

71548

P.M.F.  
L. Rubin

NRL Report 6602

# Fracture Properties of Quenched and Tempered Steel Weldment Specimens

L. J. MCGEADY

*Metallurgy Division*

October 10, 1967



**NAVAL RESEARCH LABORATORY**  
Washington, D.C.

This document has been approved for public release and sale; its distribution is unlimited.

## CONTENTS

Abstract	ii
Problem Status	ii
Authorization	ii
INTRODUCTION	1
EXPERIMENTAL PROGRAM	2
Drop-Weight Bulge Tests	4
The Delta Test	5
Preparation of DWB and Delta Test Specimens	5
TEST PROCEDURES	6
Drop-Weight Bulge Test	6
Delta Specimen Test	6
THE DROP-WEIGHT TEST TO ESTABLISH THE NDT TEMPERATURE	6
DISCUSSION	8
ACKNOWLEDGMENT	12

## ABSTRACT

Star<sup>+</sup> The development of high-strength quenched and tempered (Q&T) plate steels for use in welded construction has resulted in weldability problems different from those for carbon steel plates. Although with welded carbon steels, specification and control of the toughness of the plate metal was the solution to the brittle fracture problem in the ambient-temperature range, this is not, in general, the solution for Q&T plate steels. Q&T steels differ in several characteristics from the plain-carbon steels. Some do not show sharp transitions from tough to brittle fracture on the temperature scale. Others do not show high-energy shear characteristics in fracture. Some are of deep hardening quality and others are shallow hardening as a result of the various chemical compositions. Reasonable care in welding can assure that the weld deposit and heat affected zone (HAZ) will be tougher than the steel plates in the case of the carbon steels but this is not necessarily the case for the Q&T steels. The thermal cycling imposed by welding the Q&T plate should not be reasonably expected to produce properties in the HAZ which are identical to those in the base plate. Similarly the welding procedure for high-strength steels probably has considerable influence on the properties of the deposited weld metal. From these considerations has arisen the need to reexamine the technique to evaluate weldability of the Q&T steels.

Three test procedures were used to evaluate weldability features in seven Q&T steels. Two tests, the drop-weight bulge (DWB) test and the delta specimen test, used relatively large plate specimens containing full-thickness, multiple-pass welded joints. The loading system imposed in testing allowed fracture in them to follow a path of natural least resistance without bias from the loading direction. The third test, the drop-weight test (DWT), was used to determine the nil-ductility transition (NDT) temperature of the HAZ in the seven Q&T steels.

The results from the three test methods indicated varying degrees of sensitivity of the HAZ to welding in the seven steels. The DWB and delta specimen results were quite similar and in general agreement. The DWT demonstrated that it was possible to measure an NDT for the HAZ (except in one steel, the high alloy or rich analysis steel, which did not fail in the HAZ). The NDT temperatures in the HAZ of the six steels were significantly higher than the NDT temperatures for the parent plate, suggesting that such measurements may possibly be useful for positioning of the fracture analysis diagram (FAD) to allow for fracturing which might occur in paths lower in toughness than the base plate. The work suggests that drop weight tear test (DWTT) energy measurements in the weld HAZ of high-strength steels should be attempted.

## PROBLEM STATUS

This is an interim report on one phase of the problem.

## AUTHORIZATION

NRL Problem M03-01  
Projects RR 007-01-46-5414 and SF 020-01-01-0850

Manuscript submitted June 9, 1967.

## FRACTURE PROPERTIES OF QUENCHED AND TEMPERED STEEL WELDMENT SPECIMENS

### INTRODUCTION

As a result of the need for higher strength plate materials for general structural and naval purposes, a family of steels has developed over the past several years. Among these are the quenched and tempered (Q&T) plate steels which exceed in strength the earlier as-rolled plain-carbon steels and the later normalized and tempered carbon steels. There are various brands and types of Q&T steels having differing compositions and hardenabilities, all of which necessarily confer individual characteristics. Among the potentials these steels naturally provide as a group are their higher strength and generally superior toughness either in terms of lower nil-ductility transition (NDT) temperature or higher impact resistance, the impact resistance being the more difficult to obtain, control, and assess. Another characteristic absolutely necessary in such steels for fabricated structures is the ability to be fabricated with reasonable facility and utmost reliability into weldment structures with high resistance to brittle fracture.

With the transition from use of carbon steels to the stronger heat-treated alloy steels, a quantitative method to assess and specify the tendency of high-strength-steel weldments to brittle failure is critically needed. The measurement problem differs in the high-strength steels from the as-rolled carbon steels, for a very straightforward reason. Experience showed that the brittle fracture problem in carbon steels was mainly one of low fracture resistance of the parent plate material in paths having no necessary relation to the welds joining the plates. Therefore, recognizing that properly made welds did not result in low-toughness-weld metals or embrittled heat-affected-zones (HAZ), brittle fracture control became a matter of specification of the toughness of the plate material, the element of lowest toughness in the weldment. The nil-ductility transition (NDT) temperature and fracture analysis diagram (FAD) concepts, which evolved from investigations of the toughness of the plate metal, provided a system whereby brittle fracture in as-rolled, low-carbon, low-strength steels could be controlled and specified with a remarkable degree of confidence and precision. The relations between service failures and laboratory test types and procedures were or became understood and well documented. However, the interrelations of the weld components respecting features of strength, ductility, and fracture resistance for Q&T steels are not necessarily the same as for carbon steel weldments and tend to be more complex. Compositional differences in the high-strength family of Q&T steels are reflected in response to the welding operation. The propagated paths of extensive fractures at ordinary temperatures do not appear to be the parent plate. Thus the fracture problem in weldments of high-strength Q&T steels differs from carbon steel mainly because the parent plate is not generally the least fracture-resistant element present.

There are other differences between the Q&T steels and the as-rolled carbon steels. The NDT temperatures of the Q&T steels are generally considerably lower than those for as-rolled carbon steels of comparable thickness. The transition from tough, ductile shear fractures in carbon steels is generally sharp in terms of temperature, whereas this is not the case for the Q&T steels. In fact, not all Q&T steels exhibit high-toughness shear fractures. As another complication it should be noted that the Charpy-V impact-toughness requirement for the weld deposits of the E11018G electrode, which is commonly used to weld some of the Q&T steels, is specified as 25 ft-lb at  $-60^{\circ}\text{F}$ . This value can be lower

or higher than that for the plate, thereby resulting in a mismatch in toughness. Another complication is that the effects of welding on the HAZ of Q&T steels can hardly be expected to be predictable or necessarily beneficial. Although much has been written on this particular point, it should suffice to state that experts generally concede that the effect of many variables on HAZ properties is often one of keen concern in specifying or predicting total weldment mechanical behavior. This concern with weldment behavior in the HAZ is particularly important in fracture resistance of the Q&T steels of lean-analysis types. This problem has been indicated to be a considerable one by previous works, notably NRL investigations using explosion tests to demonstrate the sensitivity to selective failure in the HAZ in some steels.

This report will present findings relative to the problem of measurement of fracture properties of weldments of Q&T steels. Seven different Q&T steels representing the principal commercial types of the general 100,000-psi yield range were purchased and tested for fracture resistance in both the welded and nonwelded condition. Six of these steels were found to be of generally similar character in the nonwelded condition as shown by Charpy-V test, tensile tests, drop-weight tear test (DWTT) and chemical composition. The seven steels, as weldments, generally exhibited a spectrum of responses in fracture tests. Three test procedures were used to evaluate the behavior of the weldments: (a) the drop-weight bulge (DWB) test, the drop-weight test (DWT), and the delta specimen test. In general the seven steels behaved in a similar relative order of performance in the three tests. In all three test methods and procedures, it was plain that the most fracture resistant weldments were from the lower-yield-strength rich-analysis steel and the least fracture resistant were of lean-analysis types which demonstrated various levels of proneness to fracture in the HAZ. A major finding was that it was possible to measure an NDT temperature for weldment specimens with fracture occurring in or near the HAZ-fusion line area using a slightly modified DWT procedure. The NDT temperatures so determined were higher than those for the plate material by as much as 70°F for several steels.

The findings from the weldability tests indicate that: (a) susceptibility to failure can be measured using either of the three tests with generally good correspondence of results and (b) NDT temperature measurements can be made for the HAZ-fusion line area. The success in measuring the NDT temperature in the HAZ-fusion line area suggests that similar drop-weight-tear tests (DWTT) should be considered for the same steels over a range of temperatures, hopefully to measure the energy to fracture these steels in the HAZ. Companion DWTT measurement of fracture energy of weld metal as well as of parent plate should result in an additional valuable method for analyzing the fracture tendencies in Q&T steel weldments.

## EXPERIMENTAL PROGRAM

Seven steels were purchased from commercial sources for study as laboratory scale weldments with size sufficient to represent prototype conditions. The steels, except for one, were lean chemistry type, approximately 1-in. thick, quenched and tempered, ranging in yield strength from 87.0 ksi to 124.0 ksi. Details of chemical composition are given in Table 1, and the general characteristics are given in Table 2.

All chemical analyses and all measurements of tensile and other mechanical properties were made at NRL. All steels were examined for Charpy-V impact versus temperature characteristics (Fig. 1) and for DWTT values at 30°F. Also, several steels were tested by the DWTT method over a range of temperatures (Fig. 2). The NDT temperature for all steels was determined using the 3-1/2 by 14 in. specimen. Other tests related specifically to weldability were made. These tests were the DWB test, the delta test, and a modified drop-weight test (DWT).

Table 1  
Chemical Compositions of Steels Studied

Code	Composition (wt-%)									
	C	Mn	Si	P	S	Ni	Cr	Mo	V	Other
J20	0.15	0.81	0.25	0.013	0.021	0.83	0.52	-	0.24	0.55 Cu
J25	0.12	0.32	0.17	0.006	0.014	2.33	1.26	0.34	-	-
J26	0.22	0.88	0.65	0.023	0.022	0.13	0.94	0.48	-	0.10 Cu
J31	0.18	0.87	0.26	0.011	0.019	0.25	0.66	0.24	0.04	0.10 Al
J32	0.18	1.15	0.28	0.009	0.024	0.07	0.05	0.25	0.01	0.06 Al
J34	0.18	0.58	0.28	0.015	0.019	0.20	1.05	0.25	0.03	0.10 Al
J38	0.18	0.84	0.64	0.006	0.019	0.05	0.69	0.19	0.03	0.10 Al

Table 2  
Tensile Test Results

Steel Code	Plate Thickness (in.)	0.2% YS* (ksi)	UTS† (ksi)	Percent R.A.	Percent Elong.	Charpy-V§ (ft-lb at 30°F)	DWTT (ft-lb at 30°F)
J20 P‡	1	124.0	129.0	53.1	16.0	32-29	1784
T**	1	123.4	128.9	62.0	18.8	51-48	3013
J25 P	1	83.3	97.7	68.0	24.0	105-99	7500
T	1	82.9	97.8	75.1	27.0	165-162	7500
J26 P	1	106.8	120.1	53.5	19.0	32-29	2780
T	1	105.0	108.9	58.7	21.0	47-46	-
J31 P	1	113.6	121.4	48.9	15.0	26-25	1478
T	1	112.6	121.1	59.7	17.5	48-44	3633
J32 P	7/8	116.3	121.3	53.3	16.3	38-30	1662
T	7/8	116.3	122.1	61.1	18.0	44-42	2733
J34 P	1-1/8	111.3	117.3	53.2	16.5	28-27	2266
T	1-1/8	111.2	118.0	65.4	18.8	51-47	-
J38 P	1	108.8	117.7	59.2	19.0	31-30	1356
T	1	111.3	111.5	66.4	19.5	56-52	2026

\*Yield strength.

†Ultimate tensile strength.

§C<sub>v</sub> values given are the high and low values measured at 30°F. DWTT from electron beam brittle-weld, crack-starter specimens.

\*\*Fracture transverse to rolling directions.

‡Fracture parallel to rolling directions.

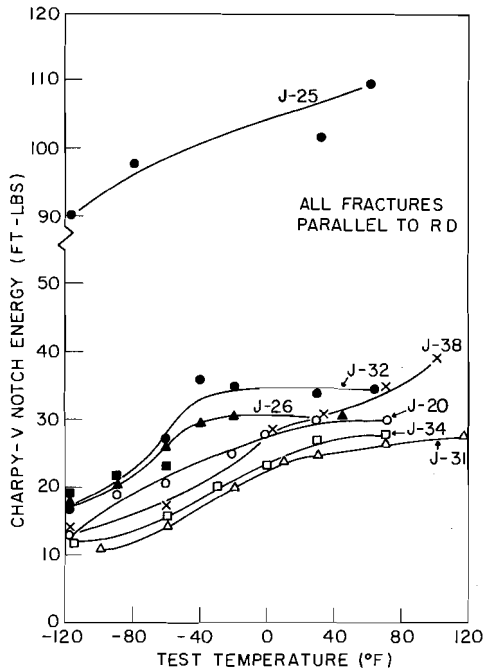

Fig. 1 - Charpy-V test curves

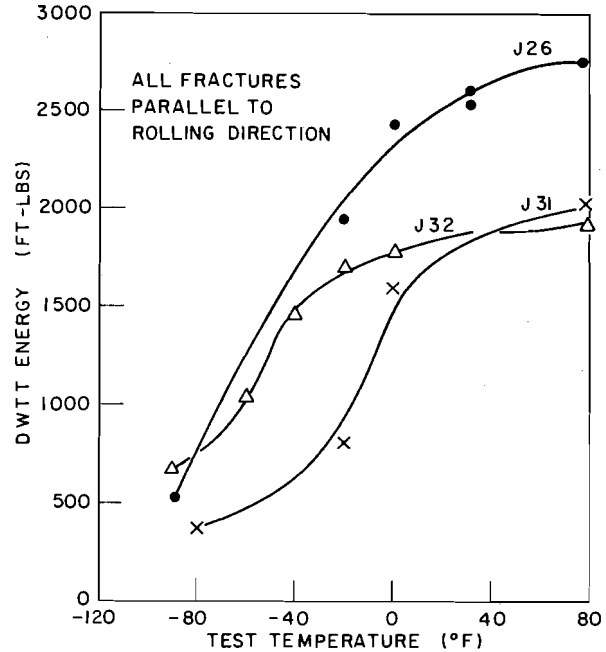

Fig. 2 - Drop-weight tear test vs temperature

### Drop-Weight Bulge Test

The DWB test was evolved at NRL from the explosion bulge test as a method which avoids the complication and cost of the latter, thereby making it a more feasible shop-type test. The test procedure is straightforward and is illustrated in Fig. 3. The specimen weldment is subjected to the impact of a massive weight dropped from a preselected height. The impact is transmitted through a dead-soft malleable aluminum tup to the 20-in. square test weldment specimen. The weldment is supported in the flat position upon an anvil with a 15-in. circular opening resting upon a massive, rigid concrete pad. The weldment can be tested at desired temperatures under controllable conditions of loading either by varying the height from which the weight is dropped or by varying the size of the weight or both. A 6-ton weight was dropped from an 8-ft height for these tests. Possible measurements include measurements of strain or bulge at failure, energy to cause failure, and source and path of failure. The loading is not prejudicial to failure in

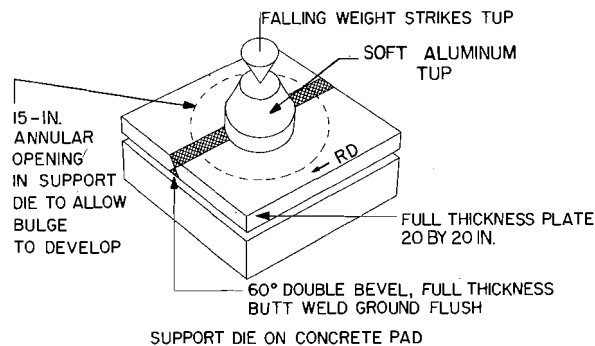

Fig. 3 - Drop-weight bulge test

any particular path or direction; and fracture once originated is free to follow any path dictated by the fracture toughness of the various paths and elements of the weldment specimen. All weld reinforcement was ground flush and smooth on both sides of the specimen prior to testing.

### The Delta Test

The delta test specimen was developed under the auspices of the Pressure Vessel Research Committee at Lafayette College. It was evolved to meet the need for a procedure which allows testing at static or low speed loading conditions using a specimen large enough to represent prototype conditions. An essential feature of the specimen is its sensitivity to welding conditions and to the various levels of fracture resistance which might be shown by the several individual elements in the weldment (HAZ, base plate, and weld metal).

Like the DWB specimen, the delta specimen is a composite made by joining components in full-plate thickness weld joints. Hence various plate rolling directions, steel types, methods of weld preparation, preheat, thermal stress relief, and other variables can be incorporated into the specimen. It features loading in a manner not prejudicial to path of failure. Figure 4 illustrates the specimen in testing, supported at the three corners as a flat plate and subjected to a dishing load from the opposite side. During the test a load-deflection record can be made, allowing energy absorption to be computed. Also the general nature and progress of failure can be observed while the test is in progress.

Fig. 4 - Delta specimen test

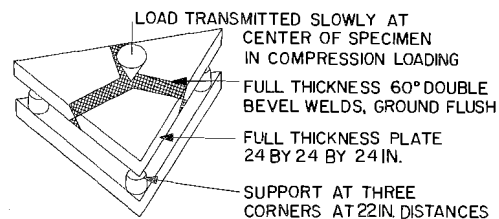

### Preparation of DWB Test and Delta Test Specimens

Both types of specimen were prepared as indicated in Figs. 3 and 4. Components of each specimen for welding were flame cut to size from the parent plate material. The rolling direction (RD) as indicated were parallel to the butt weld in the DWB test specimen and parallel to one of the welds in the delta test specimens. In both types of specimen the edges to be welded were flame cut to produce 60° double beveled faces.

Welding was performed manually using E11018G electrodes stored and dried according to recommended practices (800°F drying followed by 250°F storage). A maximum plate temperature of 100°F prior to welding was maintained, but in most cases actual plate temperature was approximately 80°F. Weld passes were deposited on alternating sides of the specimens, six passes in each side, accomplished by using two passes each with electrodes of 5/32 in., 3/16 in., and 1/4 in. successively. All beads were stringer beads, each pass directly atop the preceding one. Maximum heat input achieved was 75,000 joules/in. with the 1/4-in. electrode. Root passes were ground to fresh metal before ensuing passes were deposited.

After completion of welding, both types of specimens were sandblasted, and weld reinforcement removed by grinding flush and smooth. Following this the brittle Hardex-N crack-starter bead was applied to each specimen and then the specimens were ready for test.

## TEST PROCEDURES

### Drop-Weight Bulge Test

All DWB tests were conducted at a nominal test plate temperature of 30°F. Plates and tups were brought to a temperature of 25°F to 30°F, held for 1/2 hour in a bath of isopentane cooled by dry ice, then transferred to the drop-weight test machine and tested. A lapse of no more than 60 sec occurred before the specimen was struck by the falling weight. The temperature rise from previous experience was considered negligible in that brief time period in view of the relative insensitivity of the subject steels to temperature change in that range.

Each specimen was subjected to as many impacts as were necessary to cause extensive failure, all impacts being from a 6-ton weight dropped from an 8-ft height. Specimens which required successive blows to cause failure were returned to the cooling bath preparatory to each impact. After each impact the specimen under test was examined for evidence of failure. The aluminum tups used to transmit force from the falling weight to the specimen took the conformation of the bulged specimen, and the deformed tup was cooled with the corresponding specimen for successive blows. Failure in the DWB specimen was adjudged to have occurred when eye-visible cracking occurred outside the brittle crack-starter. The DWB testing procedure allowed the estimation of energy to cause failure to each specimen. Observation of the extent of cracking and deformation in the specimen coupled with the impact energy data accumulated on each specimen allowed some measure of the amount of energy necessary to cause failure.

### Delta Specimen Tests

The delta specimen tests like the DWB tests were conducted at 30°F. Specimens were cooled to 25°F to 30°F in isopentane and dry ice, then transferred to the testing jig for immediate testing. Since the main purpose of the test was to determine overall behavior of the materials, all specimens were merely bent to the capacity of the testing apparatus and then examined for nature of failure and correlation with results from the DWB test. Load-deflection curves were obtained for each test.

## THE DROP-WEIGHT TEST TO ESTABLISH THE NDT TEMPERATURE

Upon assembly of the test data from the DWB and delta tests, it seemed desirable to determine the NDT temperature of the HAZ area for the steels in the program. The DWT was chosen to attempt to determine the NDT temperature because if successful, the DWT presented a third and possibly "referee" method for testing weldments. Also, the NDT temperature had already been determined for each of the unwelded steels by this method. Determination of the NDT temperature in the weld HAZ or fusion line would represent additional information for application of the FAD-NDT concept to weldments where the plate material is deteriorated by welding or where the weld metal may be the controlling element in brittle fracture.

The DWT, shown in Fig. 5, was originally devised by NRL to establish the NDT temperature for plain carbon steels and for other steels where applicable. (Pellini has

Fig. 5 - Drop-weight test

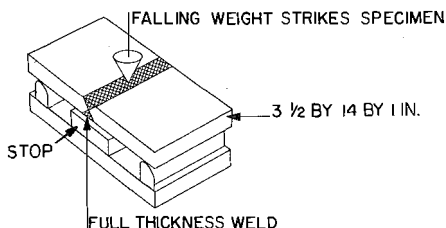

noted that the test was not advocated as universally applicable to all materials, for example, to those which develop a crack-stopping HAZ next to the crack-starter bead.) While the test program originally planned did not include material sufficient for tests at various temperatures, it appeared reasonable and desirable to conduct a program of tests of weldments at various temperatures to determine the NDT temperature using the limited quantity of materials at hand.

The conventional 3-1/2 by 14 in. DWT specimen was adopted for the steels to be tested mainly because the DWB and delta tests were conducted on the full as-rolled plate thickness of about 1 in. The DWT in full-weld joint thickness allowed the entire weldment thickness to participate in the fracture, which would progress from the specimen surface. A weld joint was necessary for the specimen which would allow a fracture in a DWT specimen to follow a straight-through path in the weldment thickness. A straight-through fracture is discouraged if beveled-but joint welds are made, since a fracture in the resulting HAZ could occur only by changing direction as necessary to follow the unlikely path of the joint bevel. Such a path of fracture in a HAZ parallel to beveled joint faces is opposed by two factors: (a) the loss of force due to resolution of applied normal forces on the plane of intended fracture and (b) the increased length of fracture path.

Preparation of the DWT specimen began by machining a 20-in. square plate into a pair of 10 by 20 in. plates as indicated in Fig. 6. A single layer of weld at moderate heat input was deposited on the butt edge of each pair of 10 by 20 in. plates to be later joined in a 20-in. butt joint. In the completed test specimen, the HAZ produced by this first pass on the plate edge presents a possibly straight-through path of failure. The first pass serves as a base, and the succeeding layers contribute the effects of multipass welding. The buildup of layers, which created a joint, was ground to produce a double 90° bevel joint for joining the two 10 by 20 in. plates.

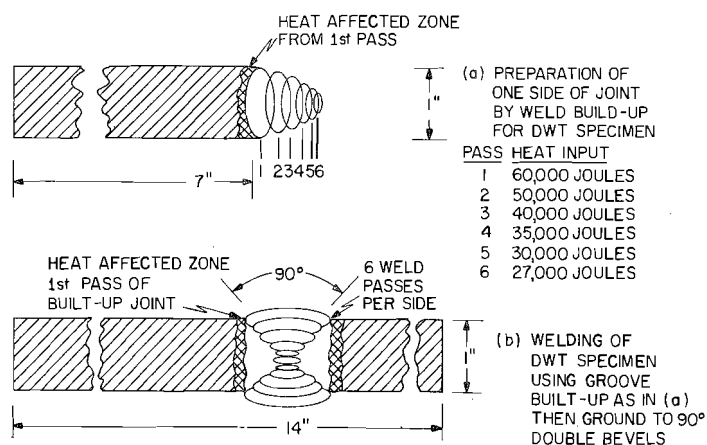

Fig. 6 - Welding preparation of DWT specimens

These joining welds, like the welds used to form the bevels, were made manually in the flat position using an E11018G electrode properly stored, baked, and held at drying temperatures. After welding, the butt joint reinforcement was removed by grinding and the 20 by 20 in. welded plates were sliced into 3-1/2 by 14 in. specimens, whereupon the crack-starter welds were applied. The crack starters were notched at the plate HAZ produced by the first welding bead deposited on that edge of the plate. (By accident two steels were notched at the center of the butt weld also.) In drop-weight testing, the specimens were positioned in the supporting anvil so that the hammer strike occurred opposite the notch in the HAZ.

## DISCUSSION

Each of the three methods used to measure relative fracture resistance in welded Q&T steels indicated that considerable deterioration can occur in the weld region, particularly in some of the lean-analysis steels.

The test results from the delta tests at 30°F shown in Table 3 definitely single out the HAZ as the limiting factor in three steels (J20, J34, and J38). Further, Table 3 indicates that extensive crack lengths in delta specimens were associated with failure in the HAZ, whereas more limited and shorter crack lengths were associated with weld metal failures. An observation that can be made from the photos of tested delta specimens (Fig. 7) is that in some steels there is indication that the weld fractures are tending toward the HAZ and possibly given a longer potential path these weld fractures would seek out the HAZ as the fracture path.

Table 3  
Comparison of Fractures in Delta Specimens  
and DWB Specimens at 30°F

Code	Delta Specimen		DWB Specimen		
	Length of Crack* (in.)	Location	Number of Impacts for Failure	Length of Crack (in.)	Location
J20	.24	HAZ	1	20	HAZ
J25	1	Weld	3	4	Weld (minor plate tear)
J26	4	Weld	3	6	Plate
J31	8	Weld (Terminated at HAZ)	3	18	Plate
J32	2	Weld	3	15	HAZ
J34	17	HAZ	2	7	Plate (3 in.) and Weld (4 in.)
J38	20	Weld and HAZ	4	20	HAZ

\*All specimens were bent in slow loading to the 3-in. maximum deflection allowed by the jig.

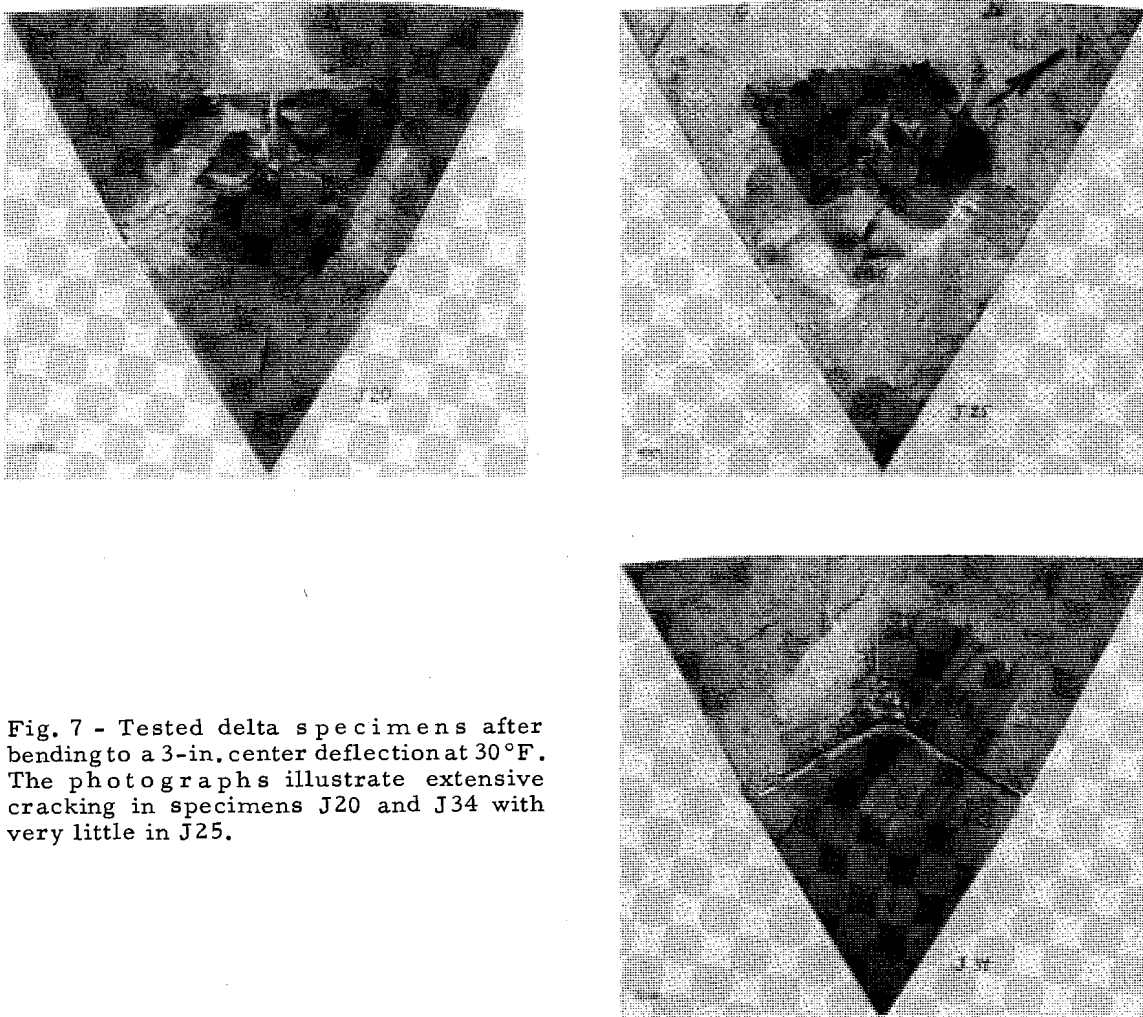

Fig. 7 - Tested delta specimens after bending to a 3-in. center deflection at 30°F. The photographs illustrate extensive cracking in specimens J20 and J34 with very little in J25.

The results of the DWB specimen tests (Table 3) agree to a large extent with those of the delta tests even though the measurements were of different type. The DWB tests consisted of repeated impacts from a 6-ton weight falling from an 8-ft height until visible indication of failure occurred. In the delta tests the weldments of all steels were bent in slow loading to the same total specimen deformation (3 in. of deflection in the jig used). In Fig. 8 is portrayed the relation found between the amount of bulge produced at failure and the energy or number of impacts required to cause failure. The data of Table 3 were used for this plot in an attempt to approximate the energy necessary to cause fracture in the various specimens. Figure 9 illustrates an attempt to correlate the results of DWB tests with those from delta specimen tests. As in the delta tests, the poorest performances for all the tests were those of the lean-analysis steels. Again (Fig. 10) the long fractures were those where the HAZ failed. (An exception is the case of J31 steel, which showed low, plate-notch toughness in the Charpy tests and failed in the plate in the DWB tests).

The results of the DWT to determine the NDT temperature may have considerable significance. The determination of the NDT characteristics of the fusion line-HAZ area may allow further interpretation and application of the NDT concept to FAD studies for the Q&T steels. It should be possible to develop individual NDT temperature information for plate, weld, and HAZ and then position the FAD on the temperature scale accordingly. It is apparent from Table 4 that for the Q&T lean-analysis steels, the NDT temperature for

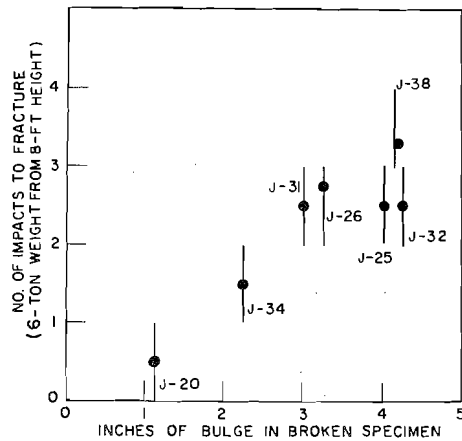
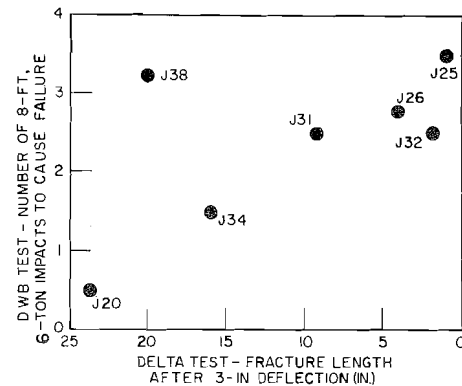

Fig. 8 - DWB tests of seven steels. The top of the bar indicates the number of impacts given each specimen to cause fracture. The heavy dot indicates the approximate energy to cause fracture as approximated on the basis of the extent and nature of the actual failure.

Fig. 9 - A comparison of behavior of steels in drop weight bulge test and delta test



fusion line-HAZ path is increased considerably over that of the plate metal, the increase varying from 20°F to 90°F in the steels tested. The modest 20°F increase occurred in steel J38 which already exhibited a relatively high NDT temperature for the unwelded plate at -50°F. A short supply of J25 steel did not permit a precise NDT temperature determination for the fusion line-HAZ area.

Certain logical and legitimate questions arise with respect to the NDT temperature determination in the fusion line-HAZ area. The first is relative to the path of failure. The photographs in Figs. 11 and 12 illustrate the path of failure through the plate thickness in a drop-weight specimen of steel J32. Although the line of fracture wanders slightly through the specimens it remains largely in the HAZ. Regardless of the path in any individual specimen, the important fact is that the NDT temperatures determined were sharp and reproducible. NDT temperature tests of weld metals on these steels should help to deduce the role of weld metal in these failures. The technical point that arises as to whether the failures were strictly in the HAZ or fusion line is probably minimized by the demonstration that the NDT temperature of the fusion line-HAZ area is higher than that of the plate.

Another question that may be raised is that of whether the weld joint is typical and representative of commercial and actual welds. The answer to this must be that the tests established the NDT temperature of a fusion line-HAZ area of a single bead made at a fixed heat input well within the limits prescribed for the steel types (too high for only J25 steel). Actual heat input for the first pass on the plate edge was 60,000 joules/in. compared to the 125,000 joules/in. recommended maximum for one of these steels at

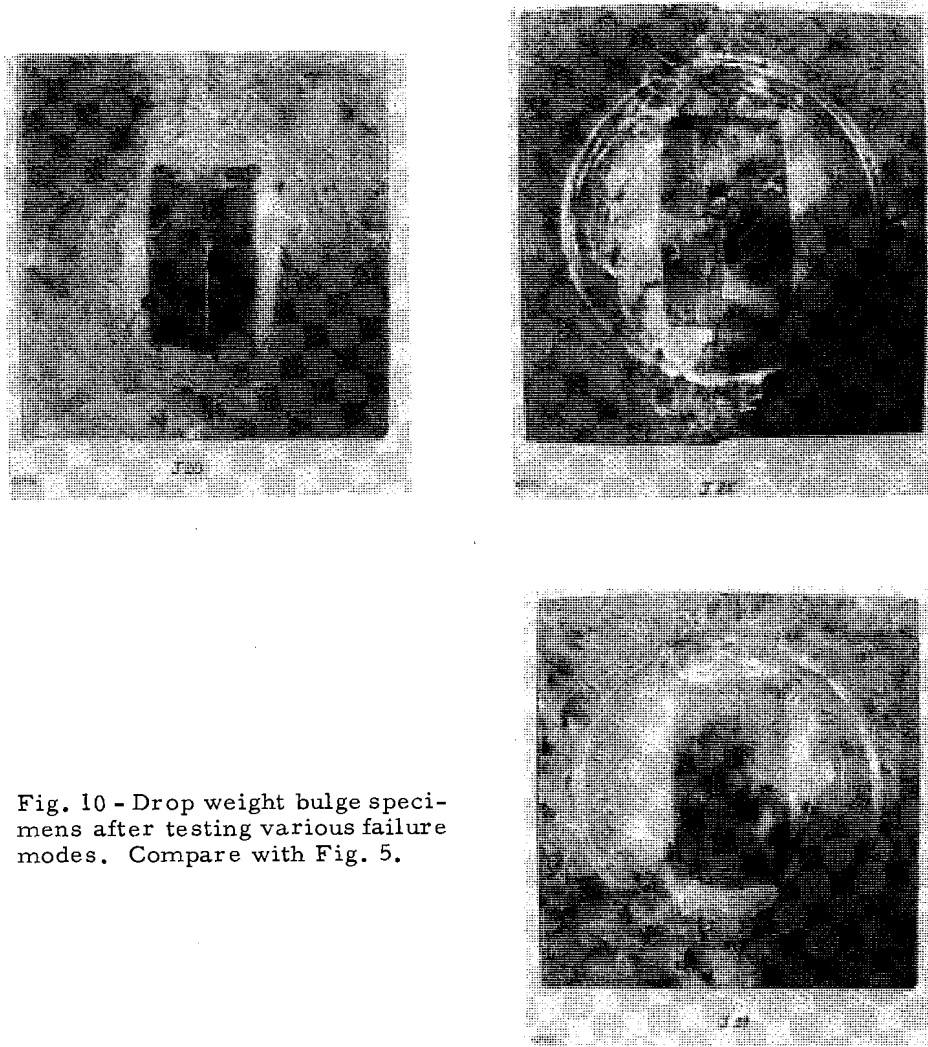

Fig. 10 - Drop weight bulge specimens after testing various failure modes. Compare with Fig. 5.

Table 4  
 NDT Temperature Comparison  
 Welded vs. Unwelded Plate Specimens  
 (3-1/2 by 14 in. Specimens)

Code	NDT Plate	NDT, Welds Fusion Line Notched	Change in NDT
J20	-80°F	-40°F	+40°F
J25	-150°F	below -50°F*	
J26	-90°F	-30°F	+60°F
J31	-80°F	+10°F	+90°F
J32	-90°F	-20°F	+70°F
J34	-80°F	-10°F	+70°F
J38	-50°F	-30°F	+20°F

\*No HAZ cracks occurred.

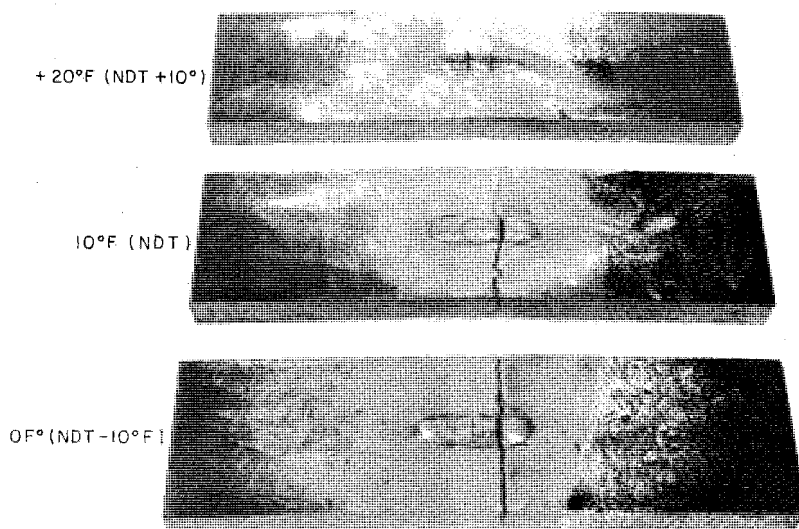

Fig. 11 - Tested drop weight weldment specimens of J31 steel macroetched to demonstrate fracture modes and paths. Non-welded plate NDT temperature for this material is  $-80^{\circ}\text{F}$ , welded specimens illustrated here were tested at  $+20^{\circ}\text{F}$  (NDT  $+10^{\circ}$ ),  $10^{\circ}\text{F}$  (NDT) and  $0^{\circ}\text{F}$  (NDT  $-10^{\circ}$ ). (Note accidentally placed notches in weld metal area in both top and bottom specimens.)

$75^{\circ}\text{F}$  (unlimited heat input for the others). It is possible that use of higher heat input welding would enlarge the HAZ of the first on-edge weld-bead. In this case the fracture path might be more localized than in the instance of the lower heat input condition used here. The effect of heat input on the measured NDT temperature in the HAZ is an item which should be investigated.

The only steel which did not fracture in the HAZ-fusion line area in the DWT was J25, which was welded (a) with an overmatching electrode (b) at a heat input in excess of the 55,000 joules/in. maximum recommended for it. At the lowest test temperature used for this steel, weld metal fractures occurred and hence no HAZ-NDT was determined for that steel.

#### ACKNOWLEDGMENT

The author gratefully acknowledges the assistance of various NRL personnel in making this report possible. The encouragement of W. S. Pellini and the administrative support of B. W. Forgeson were invaluable. Appreciation is due Dr. P. P. Puzak for his cooperation in use of the Welding Branch facilities. The enthusiastic and excellent technical assistance of Marvin Martin, James Davenport and Joseph Cobb made possible the smooth flow of laboratory testing. A. J. Kuntz gave important assistance in preparation of specimens. The late K. B. Lloyd made many contributions. R. J. Goode was helpful in the preparation of the manuscript.

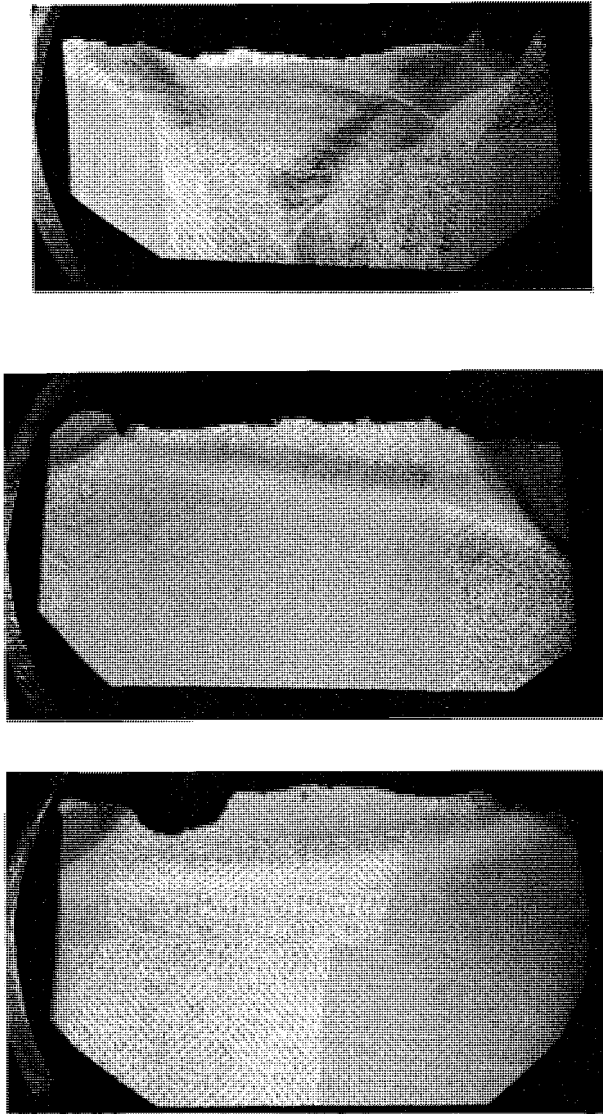

Fig. 12 - Macrographs of fractured DWT weldment specimens. Paths of fracture through plate thickness are shown at HAZ area of parent plate. Top photos show mating halves of one fracture. Bottom photo shows one-half of another specimen. Full 1-in. thickness is shown.

## DOCUMENT CONTROL DATA - R &amp; D

(Security classification of title, body of abstract and indexing annotation must be entered when the overall report is classified)

1. ORIGINATING ACTIVITY (Corporate author) Naval Research Laboratory Washington, D.C. 20390		2a. REPORT SECURITY CLASSIFICATION <b>Unclassified</b>	
		2b. GROUP	
3. REPORT TITLE <b>FRACTURE PROPERTIES OF QUENCHED AND TEMPERED STEEL WELDMENT SPECIMENS</b>			
4. DESCRIPTIVE NOTES (Type of report and inclusive dates) <b>An interim report on a continuing problem.</b>			
5. AUTHOR(S) (First name, middle initial, last name) <b>L. J. McGeady</b>			
6. REPORT DATE <b>October 10, 1967</b>		7a. TOTAL NO. OF PAGES <b>18</b>	7b. NO. OF REFS
8a. CONTRACT OR GRANT NO. <b>M03-01</b>		9a. ORIGINATOR'S REPORT NUMBER(S) <b>NRL Report 6602</b>	
b. PROJECT NO. <b>RR 007-01-46-5414</b>			
c. <b>SF 020-01-01-0850</b>		9b. OTHER REPORT NO(S) (Any other numbers that may be assigned this report)	
d.			
10. DISTRIBUTION STATEMENT <b>This document has been approved for public release and sale; its distribution is unlimited.</b>			
11. SUPPLEMENTARY NOTES		12. SPONSORING MILITARY ACTIVITY <b>Dept. of the Navy (Office of Naval Research and Naval Ship Systems Command), Washington, D.C. 20360</b>	
13. ABSTRACT <p>The development of high-strength quenched and tempered (Q&amp;T) plate steels for use in welded construction has resulted in weldability problems different from those for carbon steel plates. Although with welded carbon steels, specification and control of the toughness of the plate metal was the solution to the brittle fracture problem in the ambient-temperature range, this is not, in general, the solution for Q&amp;T plate steels. Q&amp;T steels differ in several characteristics from the plain-carbon steels. Some do not show sharp transitions from tough to brittle fracture on the temperature scale. Others do not show high-energy shear characteristics in fracture. Some are of deep hardening quality and others are shallow hardening as a result of the various chemical compositions. Reasonable care in welding can assure that the weld deposit and heat affected zone (HAZ) will be tougher than the steel plates in the case of the carbon steels but this is not necessarily the case for the Q&amp;T steels. The thermal cycling imposed by welding the Q&amp;T plate should not be reasonably expected to produce properties in the HAZ which are identical to those in the base plate. Similarly the welding procedure for high-strength steels probably has considerable influence on the properties of the deposited weld metal. From these considerations has arisen the need to reexamine the technique to evaluate weldability of the Q&amp;T steels.</p>			

— (continues)

14. KEY WORDS	LINK A		LINK B		LINK C	
	ROLE	WT	ROLE	WT	ROLE	WT
Metal fractures Quenched and tempered steels High-strength steel weldments Drop-weight tear test Drop-weight bulge test Non-ductile transition temperature Heat affected zone Brittle fractures						

Three test procedures were used to evaluate weldability features in seven Q&T steels. Two tests, the drop-weight bulge (DWB) test and the delta specimen test, used relatively large plate specimens containing full-thickness, multiple-pass welded joints. The loading system imposed in testing allowed fracture in them to follow a path of natural least resistance without bias from the loading direction. The third test, the drop-weight test (DWT), was used to determine the nil-ductility transition (NDT) temperature of the HAZ in the seven Q&T steels.

The results from the three test methods indicated varying degrees of sensitivity of the HAZ to welding in the seven steels. The DWB and delta specimen results were quite similar and in general agreement. The DWT demonstrated that it was possible to measure an NDT for the HAZ (except in one steel, the high alloy or rich analysis steel, which did not fail in the HAZ). The NDT temperatures in the HAZ of the six steels were significantly higher than the NDT temperatures for the parent plate, suggesting that such measurements may possibly be useful for positioning of the fracture analysis diagram (FAD) to allow for fracturing which might occur in paths lower in toughness than the base plate. The work suggests that drop weight tear test (DWTT) energy measurements in the weld HAZ of high-strength steels should be attempted.