



EXPERIMENTAL RESEARCH

AD 664147

U. S. ARMY

H-25 HELICOPTER

DROP TEST

22 October 1960

D D C
RECEIVED
DEC 28 1967
RECEIVED
C.B.

Approved by the
CLEARINGHOUSE
for Public Release and Sale
Information in Paragraphs 2A, 2B, 2C, 2D



FSF

AVIATION CRASH INJURY RESEARCH

A DIVISION OF

FLIGHT SAFETY FOUNDATION, Inc.

2871 SKY HARBOR BLVD. • PHOENIX, ARIZONA

TREC Technical Report 60-75

AvCIR 1-TR-124

This document has been approved
for public release and sale;
its distribution is unlimited.

106

PC	WRITE SECTION <input checked="" type="checkbox"/>
CFSTI	BUFF SECTION <input type="checkbox"/>
DDC	<input type="checkbox"/>
UNANNOUNCED	
JUSTIFICATION	
DISTRIBUTION/AVAILABILITY CODES	
DIST.	AVAIL. AND/OR SPECIAL

FLIGHT SAFETY FOUNDATION, INC.
 468 Park Avenue South
 New York, N. Y.

Jerome Lederer
 Managing Director

Merwyn A. Kraft
 Research Coordinator

Carl F. Schmidt
 Engineering Director

AVIATION CRASH INJURY RESEARCH
 A Division of Flight Safety Foundation, Inc.
 2871 Sky Harbor Blvd., Phoenix, Arizona

Merwyn A. Kraft
 Acting Director

Victor E. Rothe
 Manager

John J. Carroll
 Chief, Training Branch

Harold F. Roegner
 Chief, Investigation Branch

Alfred C. Barnes
 Chief, Statistical
 Analysis Branch

Gerard M. Bruggink
 Chief, Human Factors Branch

William H. Shook
 Chief, Experimental Research Branch

All publications of the AvCIR Division, FSF, are prepared under the supervision of a Technical Support Branch, Robert E. Klemme, Chief.

Reproduction of the paper, in whole or in part, is permitted for any purpose of the United States Government.

TREC Technical Report 60-75
AvCIR-1-TR-124

U. S. ARMY
H-25 HELICOPTER
DROP TEST

22 October 1960

PRELIMINARY REPORT

under

U. S. ARMY
TRANSPORTATION RESEARCH COMMAND
Contract DA-44-177-TC-624

AVIATION CRASH INJURY RESEARCH
A Division of
Flight Safety Foundation, Inc.

30 December 1960

FOREWORD

The contract between the U. S. Army Transportation Research Command (TRECOCM) and the Flight Safety Foundation (FSF) calls for the FSF to carry on the following activities:

"Perform crash tests of available representative types of aircraft furnished by the Contracting Officer for crash injury research, studies, and investigations."

"Test to destruction safety devices, such as shoulder harnesses, safety belts, seats, etc., to determine maximum loading, method of failure, effects of sequency of failure, etc., and report deficiencies and make recommendations of possible improvements to such safety devices."

Since a full-scale aircraft was to be crashed under simulated crash conditions, the testing of safety devices, as set forth in the second task above, could best be accomplished in the crash vehicle. The two tasks were, therefore, combined.

The initial step in performing the above tasks was to conduct a study on the various methods and techniques most suitable for achieving the desired results, along with cost estimates. The results of the study were submitted in May 1960 in a paper entitled "Preliminary Considerations for Dynamic Testing of Aircraft and Their Components."

Using this study as a basis for detailed planning, a specification* was prepared, covering the drop of an H-25 helicopter, and submitted to sixteen (16) prospective contractors during the first week of July 1960. Seven (7) proposals were received and evaluated. On the basis of the evaluation, a sub-contract was awarded to the Aeronautics Division of the Chance Vought Aircraft Corporation, Dallas, Texas, on 1 August 1960.

Chance Vought Aeronautics' personnel, Mr. R. G. Peterson and Mr. D. F. Carroll, in coordination with the Aviation Crash Injury Research Division (AvCIR) of FSF in Phoenix, Arizona, designed the drop system, installed the instrumentation, and performed the drop** on the Goodyear auxiliary airstrip of the Williams Air Force Base at Chandler, Arizona, on 22 October 1960.

* Flight Safety Foundation Specification for Dynamic Testing by Vertical Drop Piasecki Helicopter Model No. H-25A, Serial No. ID 51-16637, dated 30 June 1960.

** CVA Report No. AER-EOR 13068 dated 15 July 1960.

The data obtained from the drop was subsequently reduced and analyzed by Dr. J. W. Turnbow, Project Engineer, Dr. Richard Ditsworth, Assistant Project Engineer, and the AvCIR Staff.

Observers of the drop test included Mr. M. A. Kraft and Mr. C. F. Schmidt, representing the Flight Safety Foundation; Mr. F. P. McCourt, Mr. William Nolan, and Captain Quitman W. Jones, M. C., representing the U. S. Army; and Mr. C. B. Franklin, representing Chance Vought Aeronautics.

This preliminary report includes the details of the drop test. The data obtained has been studied and analyzed and is presented in a separate technical report.

(Reference TREC Technical Report 60-76; AvCIR 2-TR-125)

TABLE OF CONTENTS

	<u>Page</u>
LIST OF TABLES AND ILLUSTRATIONS	vii
SUMMARY	xi
ACKNOWLEDGEMENTS	xiii
INTRODUCTION	1
TEST OBJECTIVES	5
TEST REQUIREMENTS	7
PREPARATIONS FOR THE TEST	11
General	11
Instrumentation	16
TEST PROCEDURE	43
Pre-Crash Tests	43
Crash Test	43
TEST RESULTS	45
Pre-Crash Tests	45
Crash Test	47
DATA REDUCTION AND INTERPRETATION	57
CONCLUSION AND RECOMMENDATIONS	71
APPENDIX A - Various Methods of Simulating Crash Condition .	79
APPENDIX B - Design and Development Testing of Energy Absorption System for the Shock-Mounting of Air- borne Electronic Equipment	89
APPENDIX C - Calibration Techniques	99
DISTRIBUTION LIST	107

LIST OF TABLES AND ILLUSTRATIONS

			<u>Page</u>
Table	I	Instrumentation and Measurement Locations	18
Table	II	Values of K_T for CVA Resistance Box	104
Figure	1	Test Specimen Ready for Check Drop	7
Figure	2	Passenger Dummy Before Crash	8
Figure	3	Test Condition	9
Figure	4	Helicopter Ready for Crash Run	11
Figure	5	View Showing Lift System and Vertical Shock Device	12
Figure	6	Automatic Triggering Device	13
Figure	7	Front View Showing Identification Markings	14
Figure	8	Layout at Test Site	15
Figure	9	Stadia Poles at Drop Site	16
Figure	10	Instrumentation Data Sensor Installations	21
Figure	11	Instrumentation Recording Equipment Installations	23
Figure	12	Airborne Instrumentation Package	24
Figure	13	View Showing External Cameras	24
Figure	14	View of Internal Side Camera	25
Figure	15	Interior View Showing (1) Airborne Instrumentation Package, (2) Shock Device, and (3) Aft Camera	25
Figure	16	Instrumentation Equipment on Crane	27
Figure	17	Umbilical Cable Pay-Off System	27
Figure	18	End Instrument Calibration Circuit	29
Figure	19	Galvanometer Shunt Resistance Box	30

		<u>Page</u>
Figure 20	CEC 5-114 Oscillograph Control Circuit	31
Figure 21	CEC 5-122 Oscillograph Control Unit	32
Figure 22	Airborne Camera Control Circuit	34
Figure 23	Camera Delay Circuit	35
Figure 24	Ground Camera Control Circuit	36
Figure 25	Event Correlation Circuit	37
Figure 26	Oscillograph and Airborne Camera Reference Timing Circuit	38
Figure 27	Simplified Calibrator Circuit	40
Figure 28	Release Hook Circuit	41
Figure 29	View of FSF Oscillograph Shock-Mount Test Showing Energy Absorption Device After Drop	42
Figure 30	Log Drop Test Set-Up	44
Figure 31	Chance Vought Aeronautics' Pneumatic Release Hook	47
Figure 32	Post-Crash Front View	49
Figure 33	Post-Crash Front Quarter View	49
Figure 34	Post-Crash View of Right Main Landing Gear	50
Figure 35	Post-Crash View of Dummy Pilot	50
Figure 36	Post-Crash View of Dummy Passenger	51
Figure 37	Post-Crash Damage to Range Extender Fuel Tank	51
Figure 38	Oscillograph Record - Ground Oscillograph No. 1	52
Figure 39	Accelerometer Data Sign Convention	53
Figure 40	Channel 8 Vertical Acceleration of Passenger Cabin Floor	58

	<u>Page</u>
Figure 41 Channel 11 Vertical Acceleration of Cockpit Floor	59
Figure 42 Channel 4 Vertical Acceleration of Passenger Chest	60
Figure 43 Channel 14 Longitudinal Acceleration of Cockpit Floor	61
Figure 44-1 Sequence Photograph - H-25 Drop Test	65
Figure 44-2 Sequence Photograph - H-25 Drop Test	65
Figure 44-3 Sequence Photograph - H-25 Drop Test	66
Figure 44-4 Sequence Photograph - H-25 Drop Test	66
Figure 44-5 Sequence Photograph - H-25 Drop Test	67
Figure 44-6 Sequence Photograph - H-25 Drop Test	67
Figure 44-7 Sequence Photograph - H-25 Drop Test	68
Figure 44-8 Sequence Photograph - H-25 Drop Test	68
Figure A-1 Proposed Test Method of Dropping Specimen Onto 50° Inclined Plane	83
Figure A-2 Proposed Layout for Swinging Helicopter As a Pendulum	85
Figure A-3 Proposed Layout for Test Using Monorail System	86
Figure A-4 Proposed Test Method of Using Moving Crane to Drop Helicopter on Target While Moving at 35 Miles Per Hour	88
Figure B-1 Oscillograph Shock-Mount Test Set-Up Showing Energy Absorption Device and Electronic Package Before Drop	93
Figure B-2 Oscillograph Shock-Mount Test Pre-Drop Test Set-Up	95
Figure B-3 Oscillograph Shock-Mount Test Ready for a Drop	96
Figure B-4 Oscillograph Shock-Mount Test Post-Drop View	96

SUMMARY

The absence of crash performance data for rotary wing aircraft, obtained under conditions permitting engineering measurements to be made during the accident, leaves a rapidly widening gap in the design for "crashworthiness" of VTOL equipment. A long-range program, based on a series of progressive steps leading ultimately to full-scale droned crash tests, has been initiated by the Flight Safety Foundation in conjunction with the U. S. Army Transportation Research Command.

This report presents the results of an analytical study to establish methods of conducting the first exploratory tests, followed by a presentation of the methods used in the first experimental crash test. A Piasecki Model H-25A helicopter has been employed in recreating a typical accident approximating an unsuccessful attempt to attain autorotation from a low altitude power failure.

The instrumentation and research techniques used in (1) the measurement of the impact forces and accelerations, (2) the determination of the feasibility of the utilization of on-board recorders, and (3) the evaluation of certain problems inherent in the dynamic crash testing of full-scale VTOL aircraft are presented. Tentative results and the technical problems encountered are discussed and recommendations for subsequent testing are made.

ACKNOWLEDGEMENTS

The Flight Safety Foundation expresses its appreciation to the Office of the Surgeon General, Department of the Army, for the valuable services of Lt. Colonel James D. Davenport, presently assigned to the AvCIR project.

Grateful acknowledgement also goes to the Commanding Officer and the staff of Williams Air Force Base. The successful crash test of the H-25 helicopter virtually would have been impossible without their cooperation and assistance. Not only did they provide a base for operations but also the sites for both preliminary and final drops, together with fire protection and ambulance support.

Appreciation is expressed for the valuable services of James W. Turnbow, Ph. D., Professor of Engineering Science, Arizona State University, Tempe, Arizona as project engineer.

Appreciation is expressed for the valuable services of Richard Ditsworth, Ph. D., Associate Professor, Engineering Science, Arizona State University as assistant project engineer.

Appreciation also is expressed for the valuable services of the staff of Chance Vought Aeronautics in their participation in the crash test.

Finally, acknowledgement goes to I. Irving Pinkle, Chief, Fluid Systems Division, Lewis Flight Propulsion Laboratory, NASA, Cleveland, Ohio, for his guidance in the design and execution of the H-25 crash test; to personnel of Photo-Sonics, Inc. of Burbank, California for voluntary, unsolicited photographic coverage of the crash test with a newly developed high-speed 35 mm. camera; and to Derwyn M. Severy, Research Engineer, ITTE, University of California at Los Angeles for similar coverage with a 70 mm. camera. The Photo-Sonics' photography has been used in a documentary film, and the 70 mm. film has been used in several reports.

INTRODUCTION

Under USA TRECOM Contract DA-44-177-TC-624, the Flight Safety Foundation conducted a study which formed the basis for initiation of an experimental research program involving crash testing of a full-scale aircraft and dynamic testing of aircraft components. The results of this study were presented in May 1960 under the title of "Preliminary Considerations for Dynamic Testing of Aircraft and Their Components."

The initial step in conducting this study was to review the work that had been done by a number of agencies over a considerable period of time. In general, these efforts fell into three broad avenues of investigation: human tolerance to acceleration, tolerance of aircraft structure to decelerative forces, and investigation of components by commercial agencies. It was found that the results of the work accomplished in these areas over the past years were extremely beneficial in the improvement of aircraft and components from a crash-safety point of view. It was also found that little or none of the work directly applied to rotary wing and other unconventional aircraft such as V/STOL types being utilized or planned for utilization by the Army.

It was concluded, therefore, that if any significant reduction of losses is to be attained with regard to these type aircraft, it would be necessary to undertake a progressive series of carefully designed full-scale research experiments to investigate and establish the relationship between human tolerance to force and vehicle structure and components as they interact with each other in aircraft accidents involving these types of aircraft and to supplement these full-scale experiments with intermediate stage testing of components and related elements under dynamic conditions.

In studying the research plan, it was determined that the complexity of the problem would require consideration of a long-range progressive research program to be developed on the basis of experience gained as each experiment was conducted. The methods of testing could then become more elaborate as the program proceeded and could be developed in such a manner that intermediate, less expensive dynamic research facilities would be used for intermediate stage testing of components. The evaluation of the redesigned components then would be made in subsequent full-scale dynamic tests.

In the original investigation numerous methods of conducting dynamic tests on a full-scale, partial scale, or component basis (with reference to both fixed-wing and rotary-wing aircraft) were considered. While many of the methods studied could reproduce impact configurations representative of the most common and most hazardous accident experiences occurring under normal operation, it was evident that the preciseness of this reproduction would vary from method to method.

After a study of the various techniques for conducting full-scale dynamic tests, five methods which appeared to satisfy the objectives and requirements of the program were presented. These five methods were:

1. Crane Drops: This method was considered the simplest and the most logical initial approach to the experimental research program under consideration. One method involved the utilization of either a single or dual crane with the test vehicle suspended from the crane, permitting the dropping of the vehicle onto a predesigned or precalculated terrain configuration. An even better method was to drop the aircraft from a moving crane. The major limitation of these methods was that the dynamic components could not be in operation at the time of impact.
2. Aerial Tramway Drops: This method consisted of utilization of an aerial tramway, such as that developed by the Army Transportation Corps. The tramway system available offered adequate lifting capacity for lofting full-scale aircraft, and there was also a possibility that the traveling car might permit operation of the power plants of some of the aircraft as they were carried toward the site of impact. By varying the terrain underneath the drop site, many variations in impact conditions could be obtained. Although basically feasible, the aerial tramway method involved a number of unresolved problems and was not recommended except perhaps for water ditching tests if the existing installation at Ft. Eustis could be utilized without major modification.
3. Sled or Incline Releases: This method involved the mounting of a test vehicle on a sled device, propulsion of the sled by suitable rocket engines, and impacting the vehicle onto a suitably prepared impact site by releasing the vehicle at a predetermined time prior to impact. This would allow for limited forward free flight. A further variation would be the use of a high-angle incline which would obtain the desired acceleration by gravity. The high cost of the components involved appears to be the major disadvantage of this type facility.
4. Helicopter Drops: This method involved the suspension of test vehicles under existing cargo helicopters which would be used for lifting and imparting forward velocity to the test vehicles, releasing them over an impact site in a manner that would recreate desired crashes. Operationally and economically this method had much in its favor. However, it was felt doubtful whether this method could offer the assured precision essential to an experimental research program of this importance and magnitude. It was also questionable whether the desired impact conditions could be attained. This method would not permit the operation of the dynamic components of the test vehicle during the test.

5. Remote-Controlled Drones: Of the five methods of approach to the problem, the droning of test aircraft offers the most complete and accurate technique for simulating accidents. This system would permit reproduction of desired speeds, angle of impact, and attitude of the aircraft at impact which, in turn, would result in accurate reproduction of forces involved in actual aircraft accidents, including the decelerative pulses due to run-down of the rotating components of the test vehicle.

After reviewing the various methods and procedures for conducting full-scale tests, it was concluded that several of the above methods were entirely feasible, particularly the crane and remote-controlled drone systems.

Therefore, it was recommended that a long-range experimental research program be undertaken which would provide for a series of precise laboratory-controlled engineering experiments. These experiments should be conducted on a progressive and experienced basis from the simplest (crane drop) to the most complex (remote-control drone). Component and related testing should be interspersed with full-scale tests as findings dictate.

It further was recommended that this program be inaugurated by a simple drop of an H-25 helicopter from a moving crane in Phoenix, Arizona.

Upon receipt of the report submitted by the Flight Safety Foundation, the Army approved the recommendation for establishment of an experimental research program, in principle; and approved the simple crane drop of the H-25 helicopter.

The Flight Safety Foundation, through its Aviation Crash Injury Research Division, prepared a specification for dynamic testing by crane drop of the H-25 helicopter. This specification was issued to sixteen (16) prospective contractors during the first week in July of 1960 with a request that proposals be submitted before the last week of July for the work involving preparation and instrumentation of the test vehicle in a manner that would provide data in a form suitable for analysis and interpretation by the Flight Safety Foundation. Seven (7) proposals were received and evaluated, and a sub-contract was entered into with Vought Aeronautics of the Chance-Vought Aircraft Corporation on 1 August 1960.

The Vought personnel, working together with the AvCIR division staff, prepared the test vehicle and executed the drop on 22 October 1960.

This report includes preliminary information on the specific test requirements, test objectives, preparations for test, preliminary and final tests, preliminary discussions of the results with conclusions and recommendations. The data obtained during the test are presently being analyzed; detailed technical reports will be published later.

TEST OBJECTIVES

The objectives of this test program as outlined in reference (1) ^{*} were as follows:

1. To measure crash forces on pilot and/or passenger seats, seat tie-down structure, floor structure, and other components of a rotary-wing aircraft affecting occupant protection in aircraft accidents.
2. To determine the feasibility of airborne recording and the reliability of photographic and electronic recording equipment.
3. To make general determinations of problems inherent in experimental dynamic testing for use in the design of subsequent experiments of a more complex nature.

The accomplishment of Objective No. 1 would provide information which could be used for more accurate interpretation of existing post-crash data obtained from studies of actual accidents. In addition to the measurement of actual crash forces, high-speed motion picture coverage would allow observation of the dynamic behavior of the helicopter structure as well as its occupants.

Successful fulfillment of Objective No. 2 would be an important step toward the anticipated future instrumentation of drone aircraft requiring independent airborne recording systems.

Accomplishment of Objective No. 3 would prove valuable in the determination of test methods and the proper execution of future tests of a more complex nature.

* (1) Flight Safety Foundation Specification for Dynamic Testing by Vertical Drop Piasecki Helicopter Model No. H-25A, Serial No. ID 51-16637, dated 30 June 1960.

TEST REQUIREMENTS

The test requirements involved the dropping of an H-25 helicopter in a manner which would simulate a typical accident configuration within the limits specified as follows:

1. A rate of descent of 2,500 feet per minute or 29 miles per hour.
2. Angle of impact with the ground of 40 degrees.
3. Pitch angle with the ground, nose up or down, 20 degrees.
4. A flight path velocity of 45 miles per hour.

Two Alderson anthropomorphic dummies were to be placed inside the helicopter, one in the left-hand pilot's seat and the other in the forward side troop-seat of the passenger cabin. These dummies were to be instrumented to measure acceleration in various parts of the body. A Mark XII range extender fuel tank, filled with 200 pounds of colored water to simulate its normal fuel load, was to be placed in the right-hand copilot's seat. The main fuel cell was to contain 250 pounds of colored water. Sand ballast was to be added to bring the weight of the helicopter to 6,250 pounds, and the center of gravity location to the proper point. The forward and aft rotor blades were to be removed for the test.

A photograph of the test article is presented in Figure 1. A photograph of the passenger dummy is shown in Figure 2.

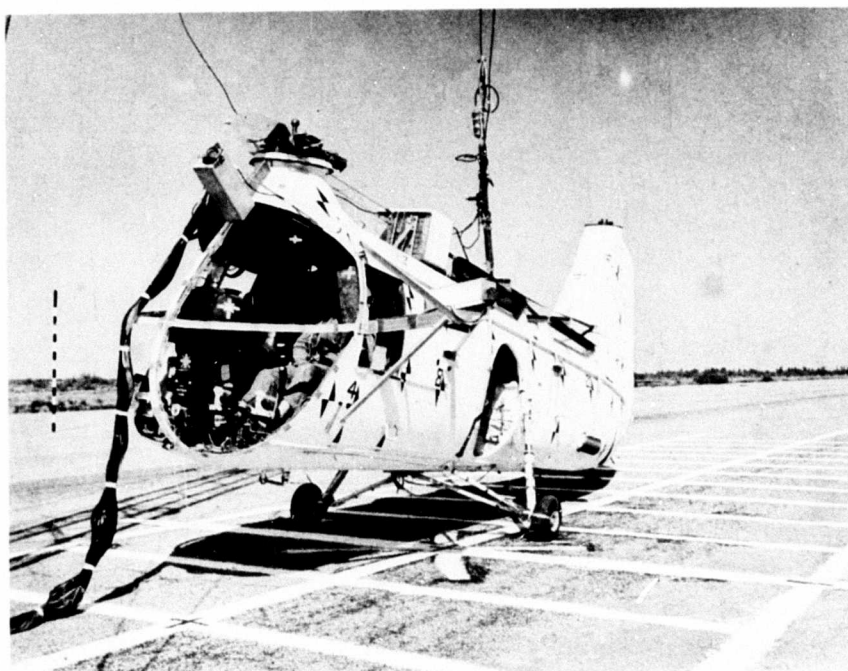

Figure 1. Test Specimen Ready for Check Drop

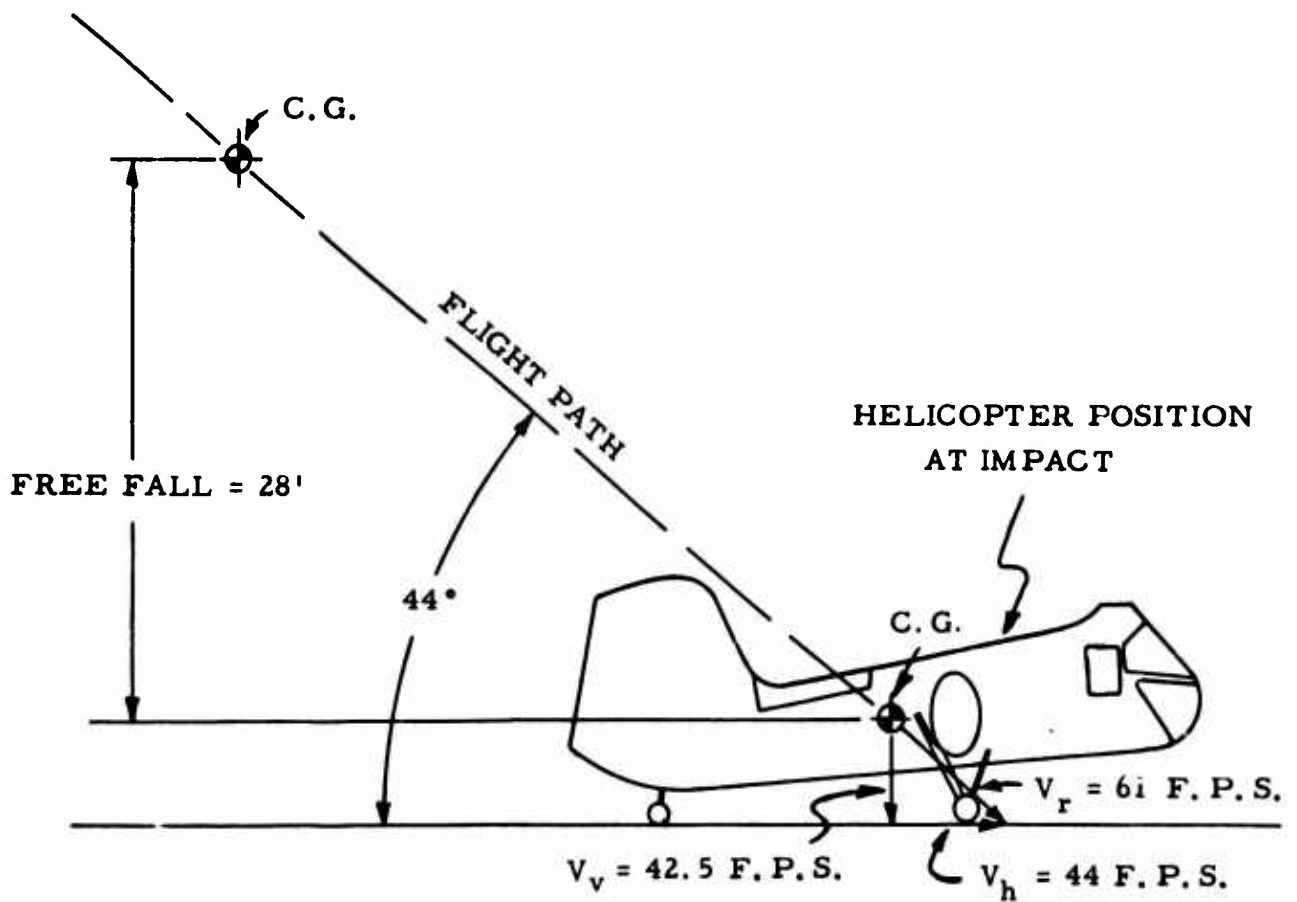

Figure 2. Passenger Dummy Before Crash

Ultimately it was required that the accident configuration be modified because of the limiting forward speed (30 MPH) of the crane selected to drop the aircraft. The final configuration is shown in Figure 3.

Suitable instrumentation was to be installed in the aircraft for simultaneous recording of acceleration and force versus time at various points on the aircraft and its passenger protection components with both airborne and ground-mounted recording equipment. The electronic equipment required to measure and record these data was to be supplied by the Flight Safety Foundation.

High-speed photographic equipment was to be mounted in the aircraft as well as on the ground covering the site of impact. The test was to be conducted at the Goodyear Auxiliary Airstrip 18 miles southwest of Williams Air Force Base, Chandler, Arizona. General supervision of the drop test experiment was to be under the direction of a project engineer appointed by the Flight Safety Foundation. The drop test was to be completed prior to 15 September 1960.



AVERAGE CRASH CONDITION:

FROM UNSUCCESSFUL AUTO-ROTATION
AFTER POWER FAILURE

FLIGHT PATH = 44° ANGLE WITH HORIZ.

FLIGHT PATH VELOCITY (RESULTANT VELOCITY)

$V_r = 41.7$ M. P. H. (61 F. P. S.)

VERTICAL VELOCITY $V_v = 29$ M. P. H. (42.5 F. P. S.)

HORIZONTAL (FORWARD) VELOCITY

$V_h = 30$ M. P. H. (44 F. P. S.)

ATTITUDE = 9° NOSE UP WITH 6° ROLL LEFT

Figure 3. Test Condition

BLANK PAGE

PREPARATIONS FOR THE TEST

A. GENERAL

1. Test Method

As already noted, several methods of establishing the impact conditions outlined under the section "Test Requirements" were investigated (see Appendix A). The method selected for the test consisted of dropping the helicopter from a moving crane. The crane suspended the helicopter at the 28-foot free-fall height necessary to duplicate the required vertical velocity, with the forward velocity of the crane vehicle providing the forward velocity of the aircraft.

The suspended helicopter was stabilized in the pitch, yaw, and roll directions during the crane run by means of a fitting, attached to the forward rotor-mount, which slipped into a socket on the crane boom. The fitting was pre-loaded vertically by hoisting the helicopter at a point forward of its center of gravity. Upon release of the helicopter, the fitting was free to slip out of the socket. Sway bracing was also provided between the main release hook and the crane boom to further stabilize the helicopter during the test run.

A photograph showing the helicopter suspended from the crane as it was in the crash test run is presented in Figure 4.

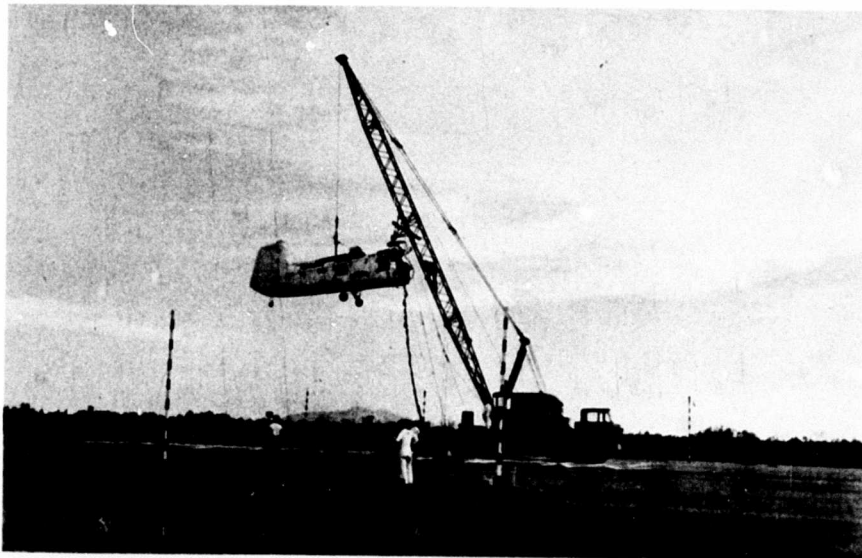

Figure 4. Helicopter Ready for Crash Run

2. Lift System

A simple hoisting arrangement was used to lift the helicopter and suspend it during the crane run. Thin steel straps were attached to each side of the fuselage at five (5) points, and were connected to a channel framework to which the release hook was attached. A photograph showing the lift system installed on the helicopter is presented in Figure 5.

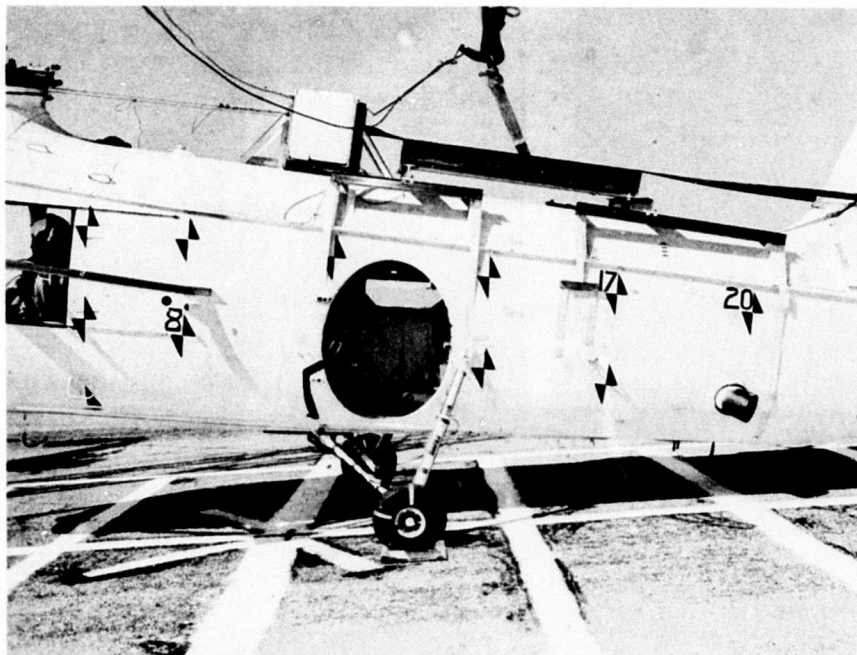

Figure 5. View Showing Lift System and Vertical Shock Device

3. Automatic Triggering Device

To release the helicopter and assure its impact on the target area, an automatic triggering device was employed using a spring-loaded switch held in place by a lever-arm. The switch was opened, and the helicopter was released when the lever-arm (mounted externally on the crane) was contacted by a stationary pole set on the ground at a predetermined distance ahead of the impact point. The triggering device is shown in the photograph in Figure 6.

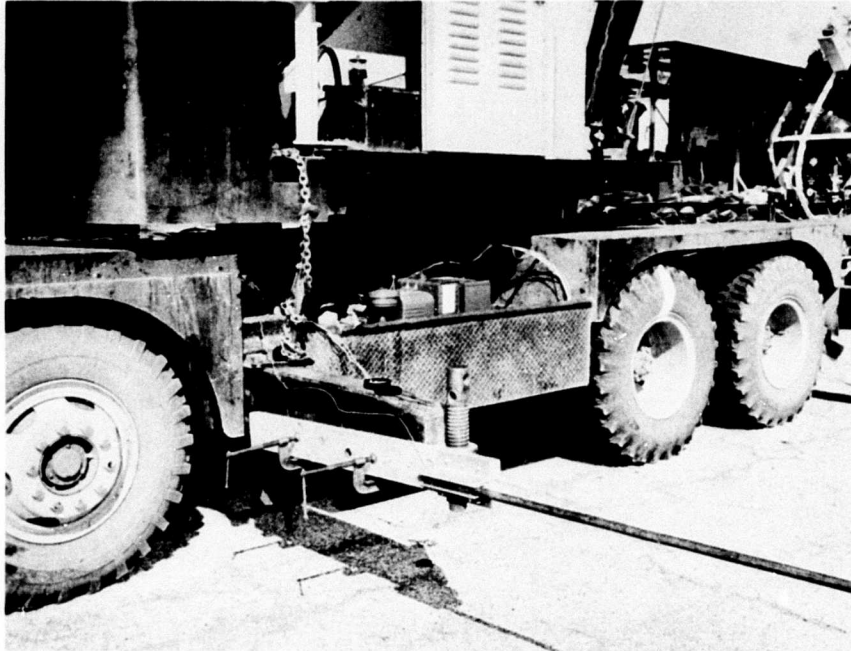

Figure 6. Automatic Triggering Device

4. Identification Markings

To serve as an aid to the high-speed movie coverage, both the interior and exterior surfaces of the helicopter were painted white. Identification markings were placed on important helicopter structure such as landing gears, fuselage frames, seat supports, etc. using red reflective tape. Markings were placed on the exterior fuselage with black paint to assist in the determination of structural deformation. The fuel cell water in both the range extender fuel tank and the main fuel cell contained red dye to show the extent of fuel flow in case of cell rupture. Photographs showing identification markings are presented in Figures 1 and 7.

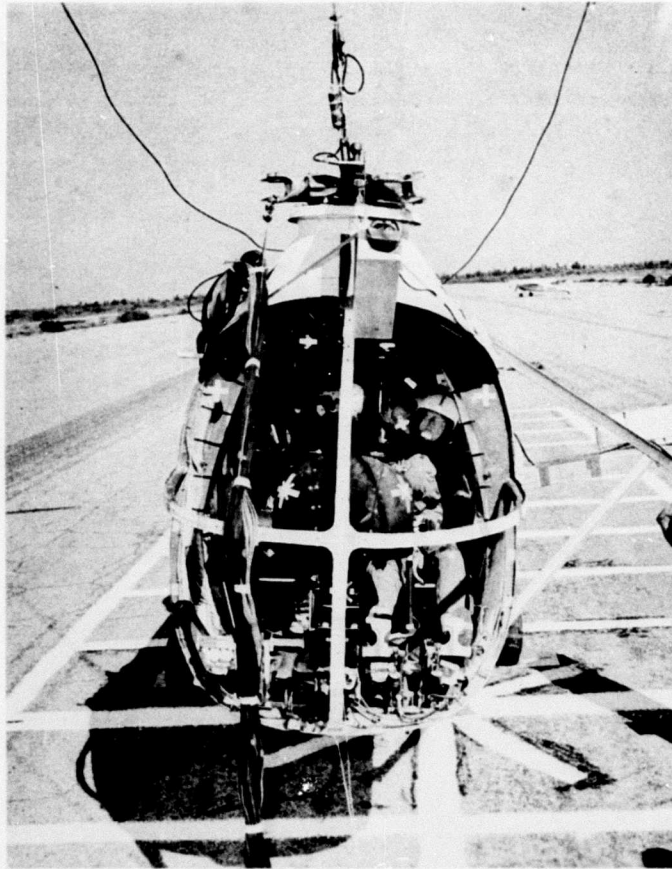
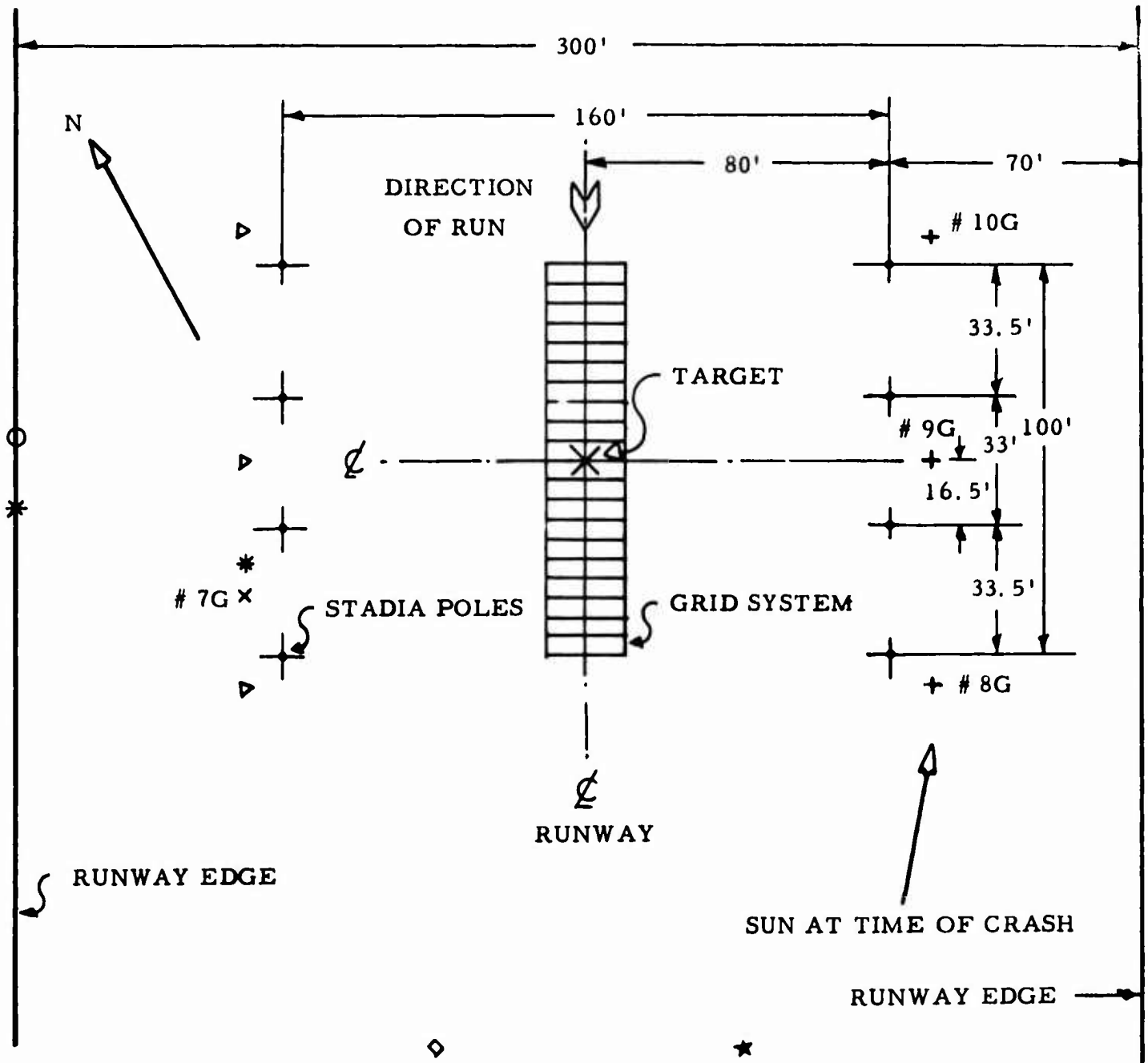

Figure 7. Front View Showing Identification Markings

A grid system, painted on the ground with whitewash at the impact site, and eight 16-foot vertical stadia poles served as a reference system for the high-speed movie coverage. A sketch showing the layout at the crash site is presented as Figure 8.



Scale: 1" = 40'0"

SYMBOLS

- STADIA POLES - 8 TOTAL
- + CVA 16 MM. 1000 F. P. S. - 3 TOTAL (NOS. 8G, 9G, & 10G)
- X CVA 16 MM. 200 F. P. S. - 1 TOTAL (NO. 7G)
- * CVA 16 MM. 24 F. P. S. (DOCUMENTARY) - 2 TOTAL
- △ PHOTOSONICS 16 MM. HI-SPEED - 3 TOTAL
- PHOTOSONICS 35 MM. HI-SPEED - 1 TOTAL
- ★ U.C.L.A. 70 MM. 48 F. P. S. - 1 TOTAL
- FSF 16 MM. 32 F. P. S. - 1 TOTAL

Figure 8. Layout at Test Site

A photograph showing the test site, with stadia poles in place, is presented in Figure 9.

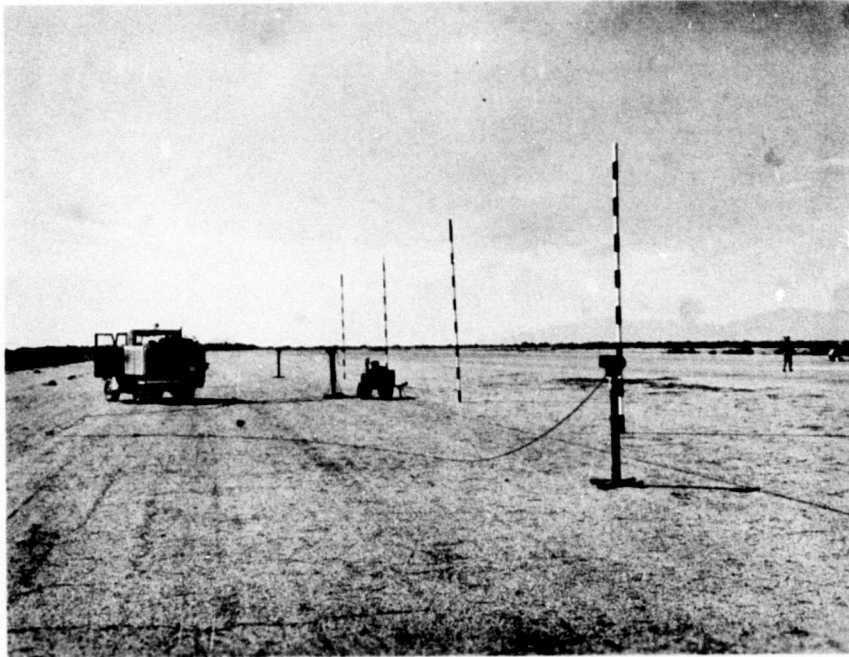

Figure 9. Stadia Poles at Drop Site

B. INSTRUMENTATION

1. General

Instrumentation of the test vehicle consisted of installing electronic pickups and cameras at the required locations and recording the data on independent airborne and ground recording systems. An umbilical cable was installed between the instrumentation pickups in the helicopter and the ground recording system.

2. Instrumentation Pickups

- a. Strain gage type accelerometers were installed to measure vertical, longitudinal and/or lateral forces at the following points:

- (1) Cockpit floor
- (2) Passenger cabin floor
- (3) Pilot's seat
- (4) Chest cavity of anthropomorphic pilot dummy
- (5) Cranial cavity of anthropomorphic pilot dummy
- (6) Pelvis of anthropomorphic pilot dummy (vertical and longitudinal only)
- (7) Chest cavity of anthropomorphic passenger dummy
- (8) Cranial cavity of anthropomorphic passenger dummy
- (9) Fuel cell aft of firewall (vertical only)
- (10) Airborne oscillograph

b. A fuel cell pressure measurement was made using a strain gage type pressure transducer immersed in the main fuel cell cavity.

c. Strain gage type tensiometers were used to measure loads at the following points:

- (1) Shoulder harness of pilot dummy
- (2) Seat belt of pilot dummy (left and right tie points)
- (3) Shoulder harness of range extension fuel tank
- (4) Seat belts of range extension fuel tank (left tie point only)
- (5) Seat belt of passenger dummy (right tie point only)

Output signals from the above-listed instrumentation were recorded on two 18-channel ground and one 26-channel airborne oscillographs. Eight (8) of the channels were simultaneously recorded on both the ground and airborne recorders. A complete listing of instrumentation to each oscillograph is presented in Table I. A sketch showing sensor installations in the helicopter is presented in Figure 10.

TABLE I
INSTRUMENTATION MEASUREMENT LOCATIONS

Oscillograph No.	Instrumentation			MEASUREMENT	Force Direction
	Channel	Pick-up Type	Range		
1	Accelerometer	50 G	Passenger Dummy-Chest Cavity	Lateral	
2	Accelerometer	10 G	Passenger Dummy-Chest Cavity	Longitudinal	
3	Impact Switch	BLIP	CORRELATION	-----	
4	Accelerometer	50 G	Passenger Dummy-Chest Cavity	Vertical	
5	Accelerometer	20 G	Passenger Cabin Floor	Lateral	
6	Accelerometer	100 G	Passenger Cabin Floor	Longitudinal	
7	-----	-----	-----	-----	
8	Accelerometer	100 G	Passenger Cabin Floor	Vertical	
9	-----	-----	-----	-----	
10	Accelerometer	50 G	Passenger Dummy-Cranial Cavity	Lateral	
11	Accelerometer	100 G	Cockpit Floor	Vertical	
12	-----	-----	-----	-----	
13	Accelerometer	20 G	Cockpit Floor	Lateral	
14	Accelerometer	100 G	Cockpit Floor	Longitudinal	
15	Accelerometer	10 G	Passenger Dummy-Cranial Cavity	Longitudinal	
16	Accelerometer	50 G	Passenger Dummy-Cranial Cavity	Vertical	
17	Tensiometer	0 - 5000#	Passenger Dummy-Seat Belt	Tension	
18	A. C. Generator	60 cps	Timing		

TABLE I, Cont'd.

Oscillograph No.	Channel	Instrumentation		MEASUREMENT	Force Direction
		Pick-up Type	Range		
2 (Ground System)	1	Accelerometer	10 G	Pilot Dummy-Chest Cavity	Lateral
	2	Accelerometer	50 G	Pilot Dummy-Chest Cavity	Longitudinal
	3	Impact Switch	BLIP	CORRELATION	-----
	4	Accelerometer	50 G	Pilot Dummy-Chest Cavity	Vertical
	5	-----	-----	-----	-----
	6	Accelerometer	50 G	Pilot Dummy-Pelvis	Longitudinal
	7	Accelerometer	50 G	Pilot Dummy-Pelvis	Vertical
	8	Tensiometer	0	-----	-----
	9	Accelerometer	5000#	Pilot Dummy-Seat Belt LH.	-----
	10	Accelerometer	10 G	Airborne Oscillograph	Lateral
	11	Accelerometer	20 G	Airborne Oscillograph	Longitudinal
	12	Accelerometer	20	-----	-----
	13	Accelerometer	20	Airborne Oscillograph	Vertical
	14	Tensiometer	0 -	-----	-----
	15	-----	5000#	Pilot Dummy-Seat Belt RH.	Tension
	16	Tensiometer	0 -	-----	-----
	17	-----	5000#	Pilot Dummy-Shoulder Harness	Tension
	18	A. C. Generator	60 cps	Timing	-----

TABLE I Cont'd.

Oscillograph No.	Channel	Instrumentation		MEASUREMENT	Force Direction
		Pick-up Type	Range		
3 (Airborne System)	1	Accelerometer	± 10 G	Passenger Dummy-Chest Cavity	Lateral
	2	Accelerometer	-----	-----	-----
	3	Accelerometer	± 50 G	Passenger Dummy-Chest Cavity	Longitudinal
	4	Accelerometer	± 50 G	Passenger Dummy-Chest Cavity	Vertical
	5	-----	-----	-----	-----
	6	Accelerometer	± 20 G	Passenger Cabin Floor	Lateral
	7	Accelerometer	± 100 G	Passenger Cabin Floor	Longitudinal
	8	-----	-----	-----	-----
	9	Accelerometer	± 100 G	Passenger Cabin Floor	Vertical
	10	Accelerometer	± 50 G	Dummy Passenger-Cranial Cavity	Lateral
	11	-----	-----	-----	-----
	12	Accelerometer	± 100 G	Cockpit Floor	Vertical
	13	-----	-----	-----	-----
	14	Accelerometer	10 G	Pilot's Seat	Lateral
	15	Accelerometer	100 G	Pilot's Seat	Longitudinal
	16	Transducer	0-100 PSI	Fuel Cell Pressure	-----
	17	Accelerometer	± 100 G	Pilot's Seat	Vertical
	18	Accelerometer	± 10 G	Pilot Dummy-Cranial Cavity	Lateral
	19	Accelerometer	± 50 G	Pilot Dummy-Cranial Cavity	Longitudinal
	20	Accelerometer	± 100 G	Fuel Cell Wall-Sta. 173.6	Vertical
	21	Accelerometer	± 50 G	Pilot Dummy-Cranial Cavity	Vertical
	22	Tensiometer	0 - 5000#	Range Extension Fuel Cell - Seat Belt	Tension
	23	Tensiometer	0 - 5000#	Range Extension Fuel Cell - Shoulder Harness	Tension
	24	A.C. Generator	60 cps	Timing	-----
	25	Impact Switch	BLIP	CORRELATION	-----
	26	-----	-----	-----	-----

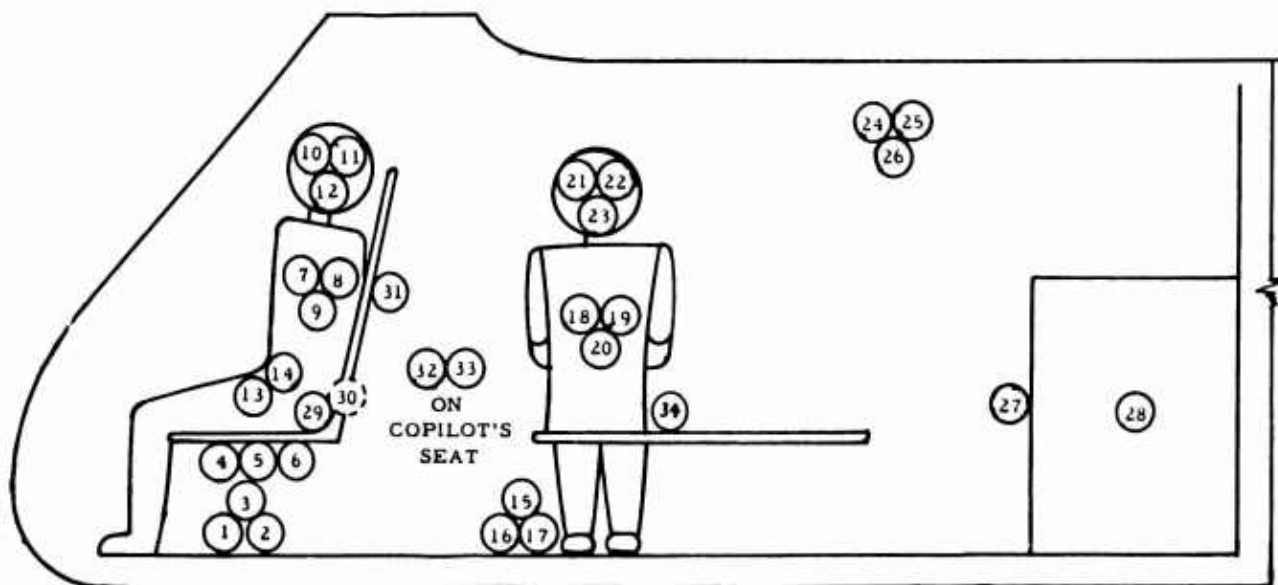

- | | |
|--|---|
| 1. Cockpit Floor Acceleration - Lateral | 16. Passenger Cabin Floor Acceleration - Longitudinal |
| 2. Cockpit Floor Acceleration - Longitudinal | 17. Passenger Cabin Floor Acceleration - Vertical |
| 3. Cockpit Floor Acceleration - Vertical | 18. Passenger Chest Acceleration |
| 4. Pilot's Seat Acceleration - Lateral | 19. Passenger Chest Acceleration - Longitudinal |
| 5. Pilot's Seat Acceleration - Longitudinal | 20. Passenger Chest Acceleration - Vertical |
| 6. Pilot's Seat Acceleration - Vertical | 21. Passenger Head Acceleration - Lateral |
| 7. Pilot's Chest Acceleration - Lateral | 22. Passenger Head Acceleration - Longitudinal |
| 8. Pilot's Chest Acceleration - Longitudinal | 23. Passenger Head Acceleration - Vertical |
| 9. Pilot's Chest Acceleration - Vertical | 24. Equipment Package Acceleration - Lateral |
| 10. Pilot's Head Acceleration - Lateral | 25. Equipment Package Acceleration - Longitudinal |
| 11. Pilot's Head Acceleration - Longitudinal | 26. Equipment Package Acceleration - Vertical |
| 12. Pilot's Head Acceleration - Vertical | 27. Fuel Tank Acceleration - Vertical |
| 13. Pilot's Pelvis Acceleration - Longitudinal | 28. Fuel Tank Pressure |
| 14. Pilot's Pelvis Acceleration - Vertical | 29. Pilot's Seat Belt Force (Right) |
| 15. Passenger Cabin Floor Acceleration - Lateral | 30. Pilot's Seat Belt Force (Left) |
| | 31. Pilot's Shoulder Harness Force |
| | 32. Fuel Tank Seat Belt Force |
| | 33. Fuel Tank Shoulder Harness Force |
| | 34. Passenger Seat Belt Force |

Figure 10. Instrumentation Data Sensor Installations

3. Recording Systems

a. Airborne Setup

The airborne oscillograph recording and photographic systems, having their own power sources, were independent of the ground system except that the ground calibrator was used for calibration of the airborne oscillograph. The airborne setup included the following equipment:

(1) Oscillograph Recording System

- (a) 1 - CEC 5-122 Oscillograph (26-channel)
- (b) 1 - Leland SE-2 Inverter
- (c) 1 - CEC 5-053 Timer

(2) Photographic Recording System

- (a) 2 - Photosonics Hi-Speed Camera with 5.3 mm. Wollensak lens
- (b) 1 - Photosonics Hi-Speed Camera with right angle optical system and 5.3 mm. Wollensak lens
- (c) 1 - Photosonics Hi-Speed camera with 1/2-inch f2.3 Wollensak lens
- (d) 2 - Bell & Howell Gunsight camera

(3) Airborne Systems Power Supply

- (a) 3 - Sonotone 10H120 (30V) Nicad Battery

A sketch showing location of airborne equipment is presented in Figure 11. A detailed description of the airborne recording system, including circuit diagrams, is presented in Appendix B. Photographs showing the airborne instrumentation package and camera installations are presented in Figures 12 through 15.

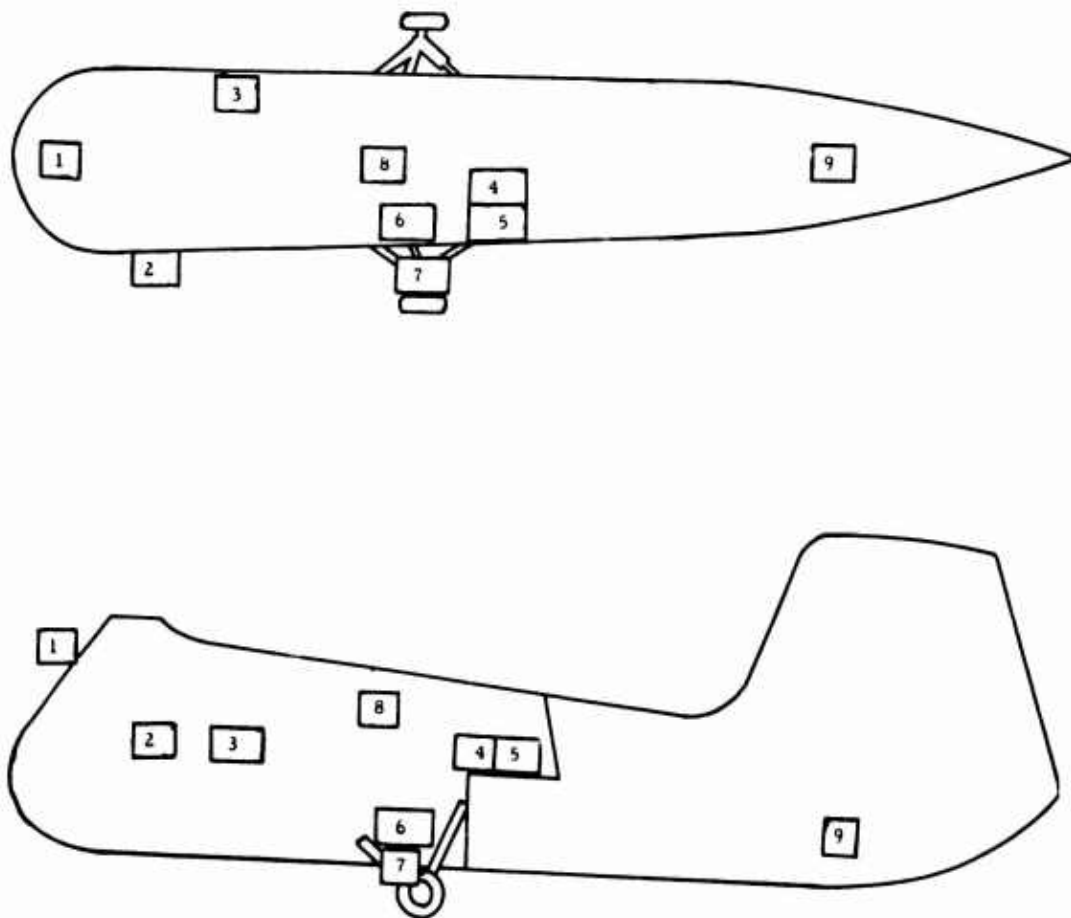

- | | |
|-----------------------------|---------------------------|
| 1. HIGH SPEED CAMERA NO. 1A | 8. EQUIPMENT PACKAGE |
| 2. HIGH SPEED CAMERA NO. 2A | CONTAINING: |
| 3. HIGH SPEED CAMERA NO. 3A | A. CEC 5-122 OSCILLOGRAPH |
| 4. HIGH SPEED CAMERA NO. 4A | B. CEC TIMER |
| 5. LOW SPEED CAMERA NO. 5A | C. LELAND INVERTER |
| 6. LOW SPEED CAMERA NO. 6A | D. RELAYS |
| 7. IMPACT SWITCH | 9. BATTERIES |

Figure 11. Instrumentation Recording Equipment Installations

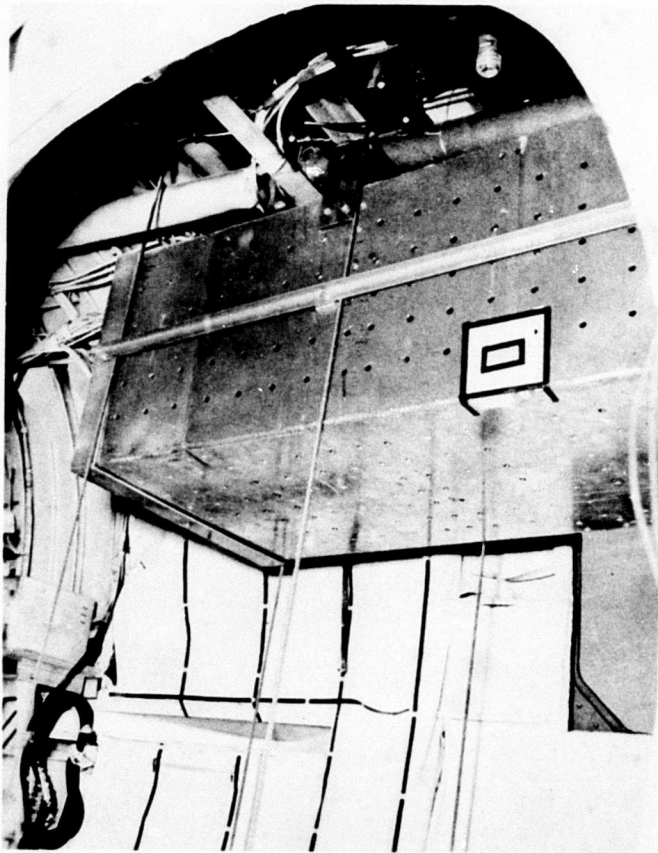

Figure 12. Airborne
Instrumentation Package

Figure 13. View Showing
External Cameras

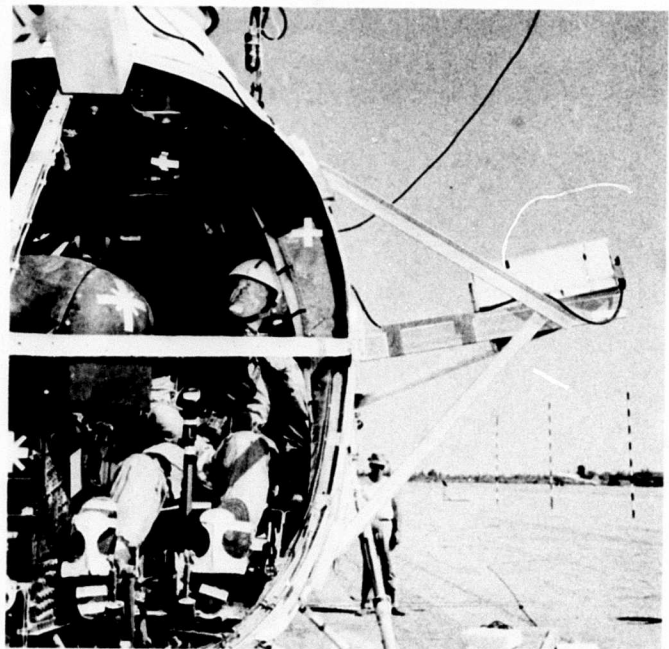

Figure 14. View of Internal Side Camera

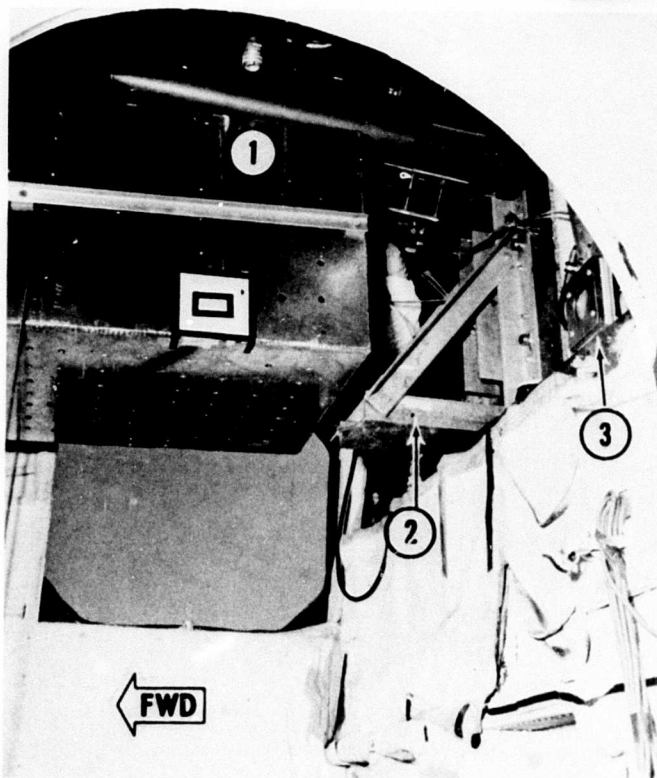
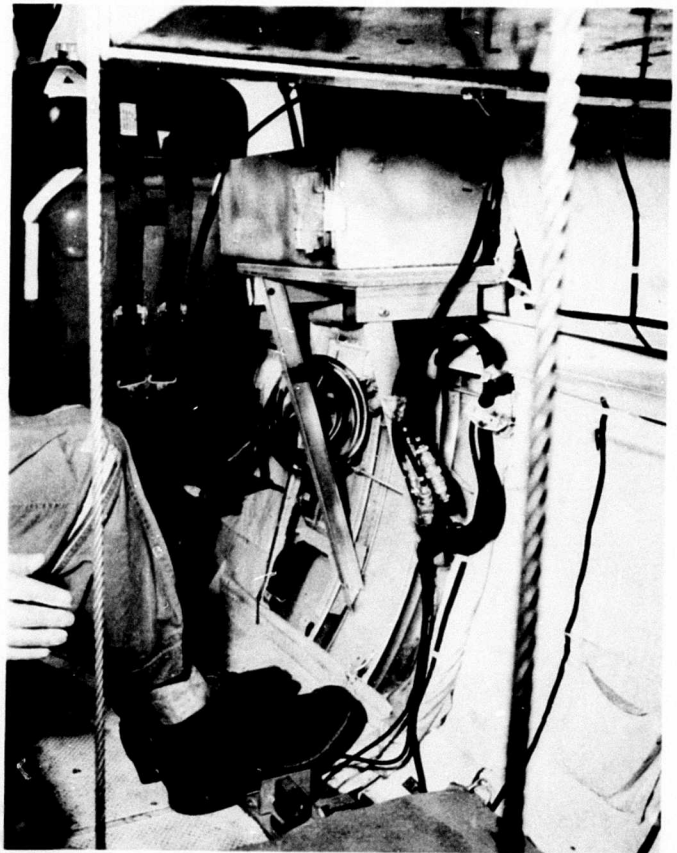

Figure 15. Interior View Showing (1) Airborne Instrumentation Package, (2) Shock Device, and (3) Aft Camera

b. Ground Setup

The ground oscillograph recording system, having its own power supply, was shock-mounted to the rear deck of the drop crane. The ground photographic system and its power source was located on the ground near the crash site. The ground setup included the following equipment:

(1) Oscillograph Recording System

- (a) 2 - CEC 5-114 Oscillograph (18-channel)
- (b) 1 - CVA Calibrator (36-channel)
- (c) 1 - Sonotone 20H120 (12V) Nicad Battery
- (d) 1 - 23V Lead Acid Battery
- (e) 1 - PE75 Auxiliary Power Unit (U. S. Army) 115V-AC, 2.5 KW

(2) Photographic Recording System

- (a) 4 - Fairchild Hi-Speed Camera
- (b) 1 - 110V AC Power Unit
- (c) 1 - 28V DC Power Unit

A detailed description of the ground recording system, including circuit diagrams, is presented in Figures 18 through 28. A photograph showing the ground instrumentation system mounted on the drop crane is presented as Figure 16.

4. Umbilical Cable

The umbilical cable installed between airborne instrumentation pickups and the ground recording system located on the crane deck had a maximum play-out length of 100 feet. A disconnect panel was provided should the distance between the helicopter and crane exceed the length. A photograph showing the cable in place on the drop crane is presented in Figure 17.

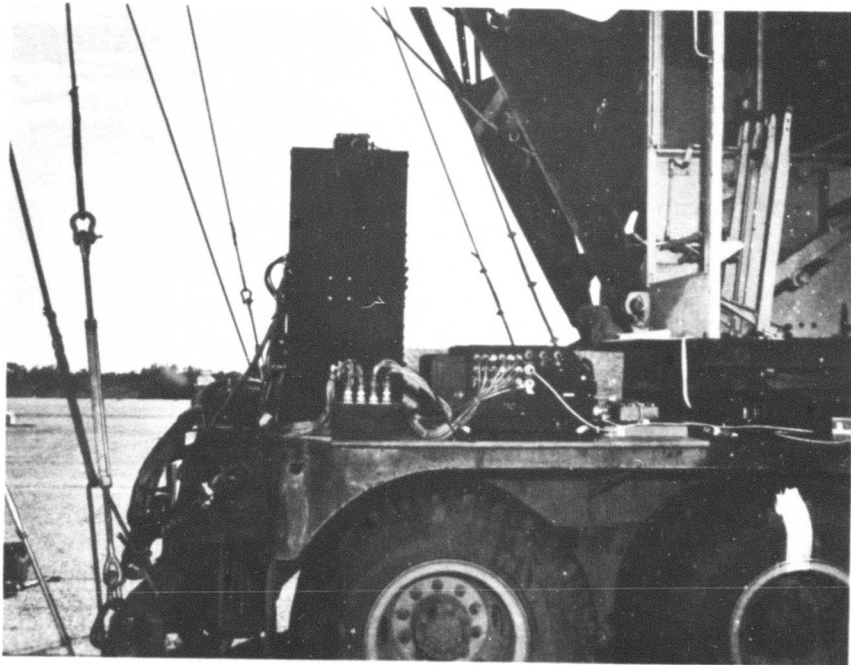

Figure 16. Instrumentation Equipment on Crane



Figure 17. Umbilical Cable Pay-Off System

5. Instrumentation Details

a. End Instrument Artery Circuit

- (1) The end instruments, consisting of twenty-seven (27) accelerometers and six (6) force links, were connected to the calibrator installed on the crane deck by thirty-five (35) Belden #8424 shielded cables. The outputs of the calibrator were connected through Belden #8422 shielded cable to the galvanometer inputs on each oscillograph. A block diagram of the end instrument artery circuit is presented as Figure 18.
- (2) Galvanometer Shunt Resistance Box - In order to record the output of one measurement channel on two oscillograph galvanometers simultaneously, it was necessary to provide an impedance matching circuit to maintain a 64 percent critical damping factor for each galvanometer. A schematic for the eight-channel shunt box designed for this purpose is presented as Figure 19.

b. Control Circuits

- (1) CEC 5-114 Ground Oscillographs - The 115V AC, 60 cps, power for the operation of the ground oscillographs was provided by a 2.5 KW portable generator mounted on the drop crane. The oscillograph was actuated by closure of the record relay in each oscillograph by a switch on the master control panel. A schematic of the ground oscillograph control circuit is presented as Figure 20.
- (2) CEC 5-122 Airborne Oscillograph - The 115V AC, 400 cps, 3-phase power for the operation of the airborne oscillograph was provided by a Leland SE-2 Rotary Inverter which was operated by a 28V DC battery mounted in the rear of the helicopter. Operation of the Leland Inverter was controlled by a switch on the master control panel which actuated a relay in the inverter input line. The oscillograph was controlled by a switch on the master control panel which actuated the record relay in the oscillograph. Another switch on the master control panel provided for selection of a high speed or low speed operational mode. The low-speed mode was used for recording the end instrument calibration and the high-speed mode was used for the recording of the actual drop. A schematic of the airborne oscillograph control system is presented as Figure 21.

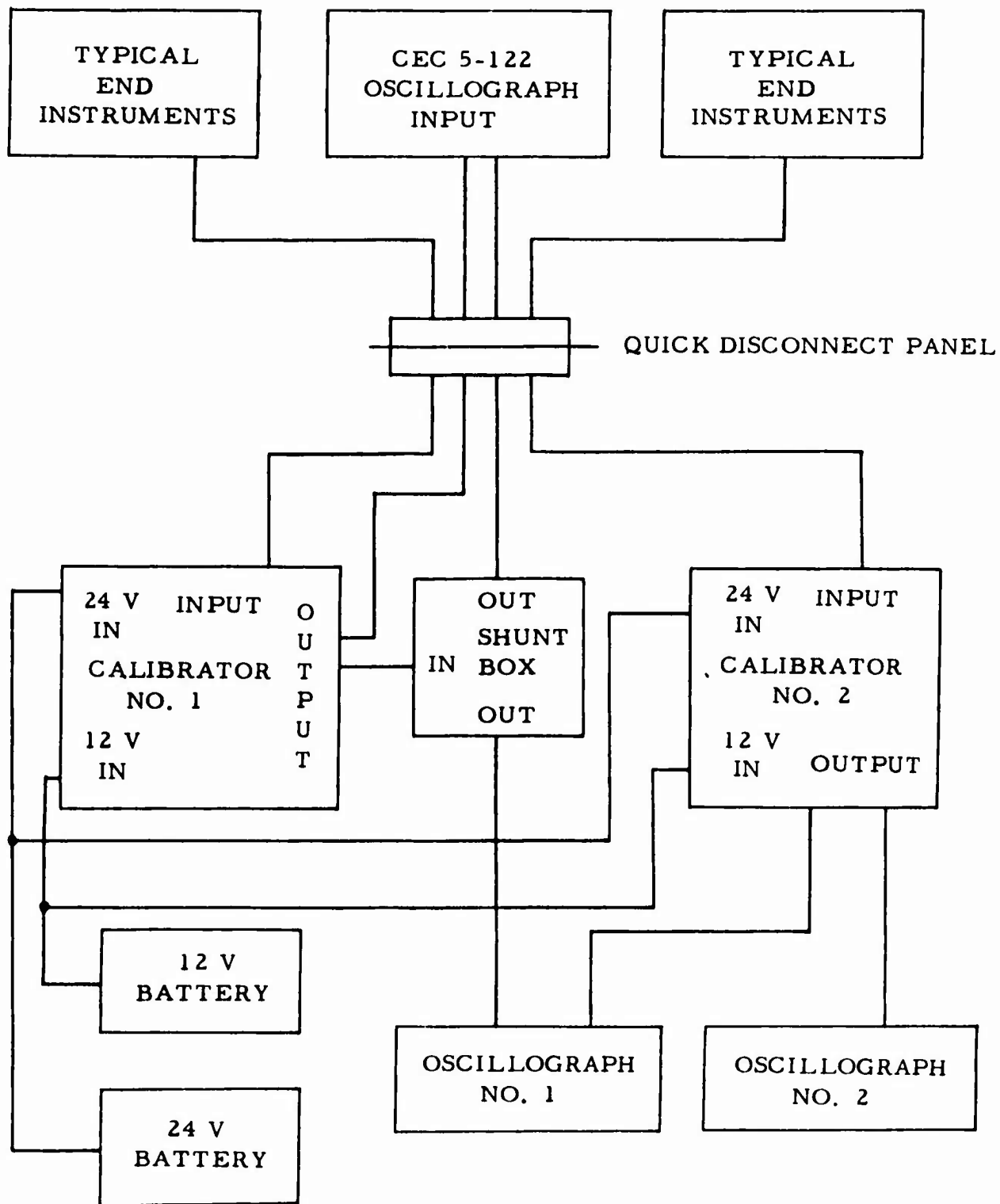

Figure 18. End Instrument Calibration Circuit

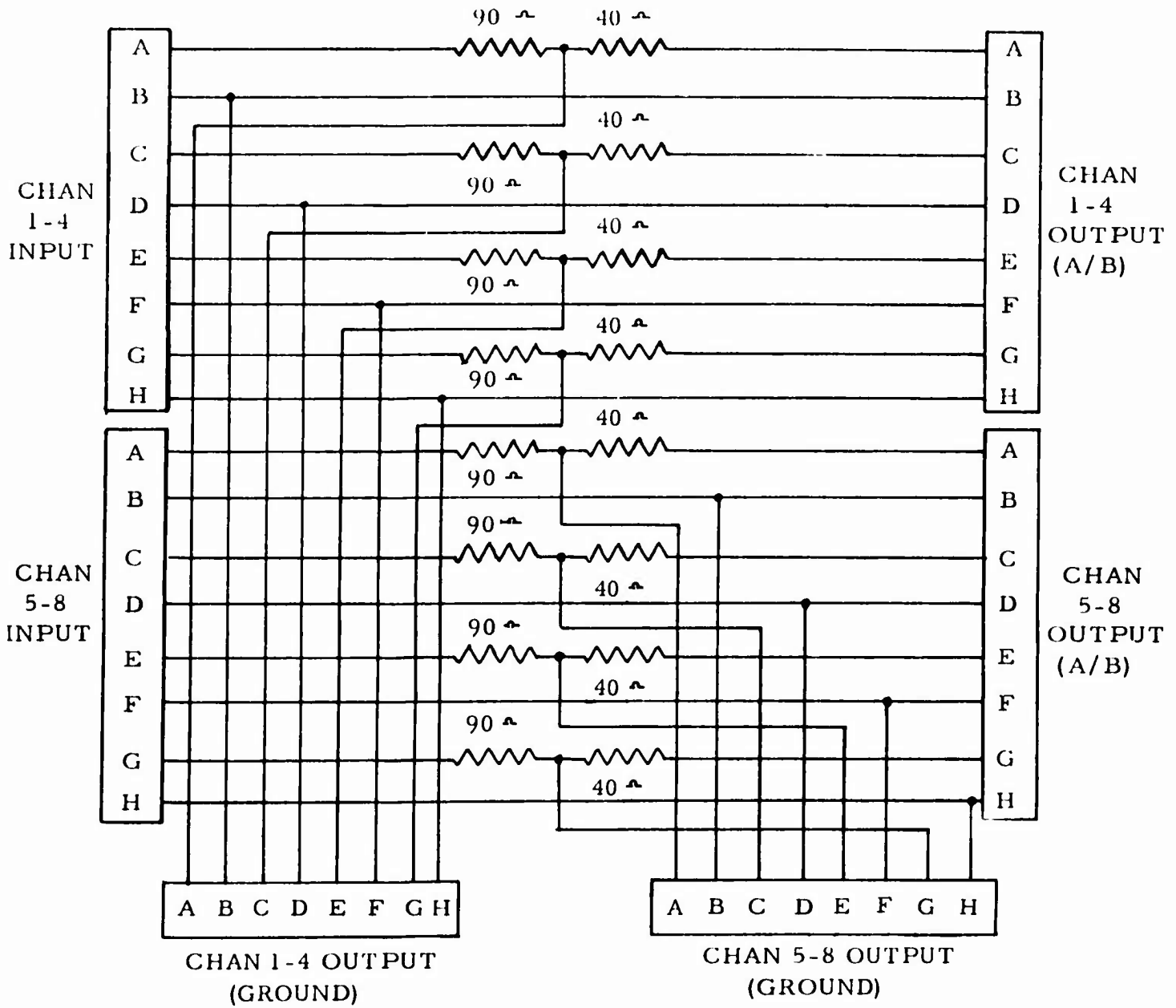

Figure 19. Galvanometer Shunt Resistance Box

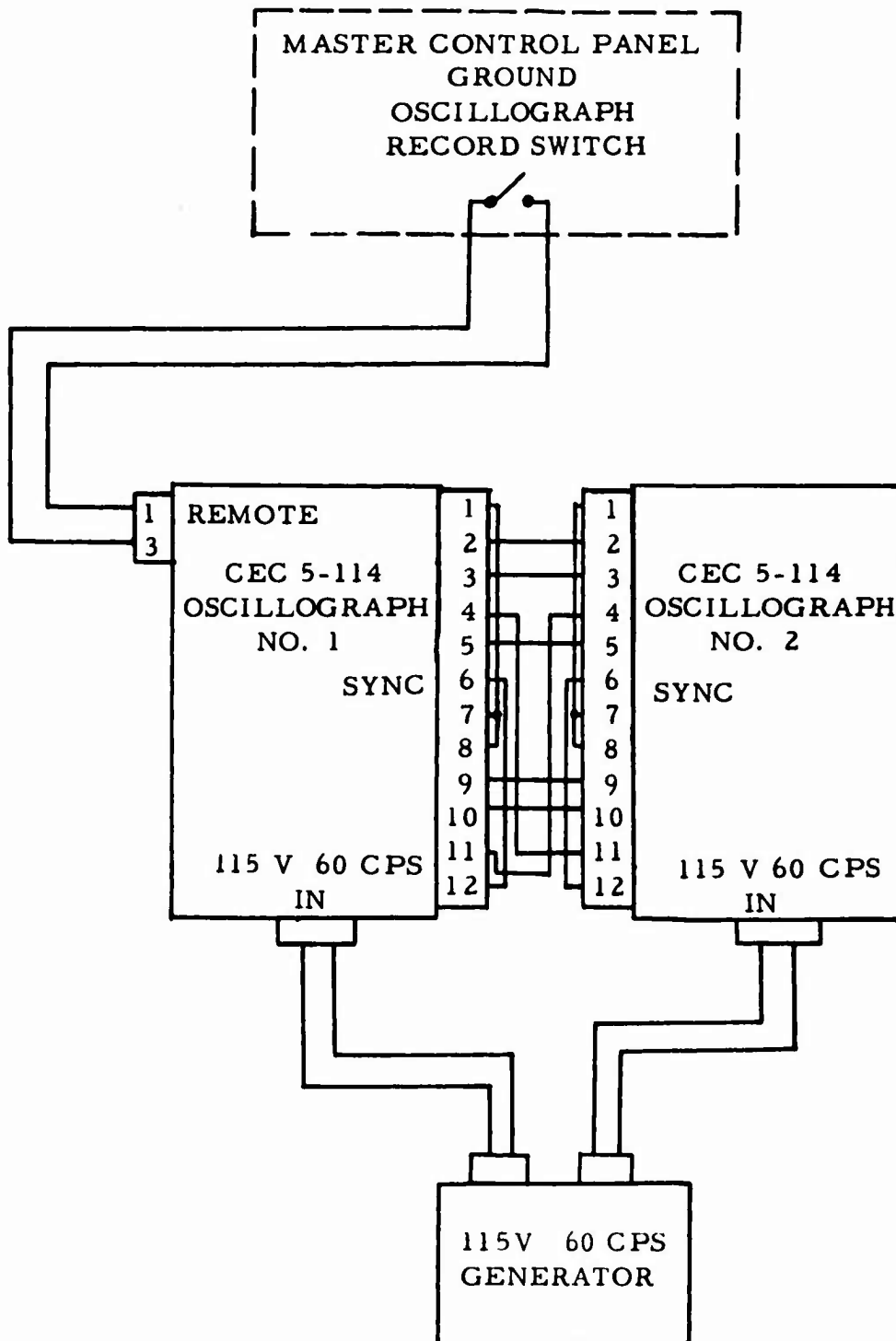

Figure 20. CEC 5-114 Oscillograph Control Circuit

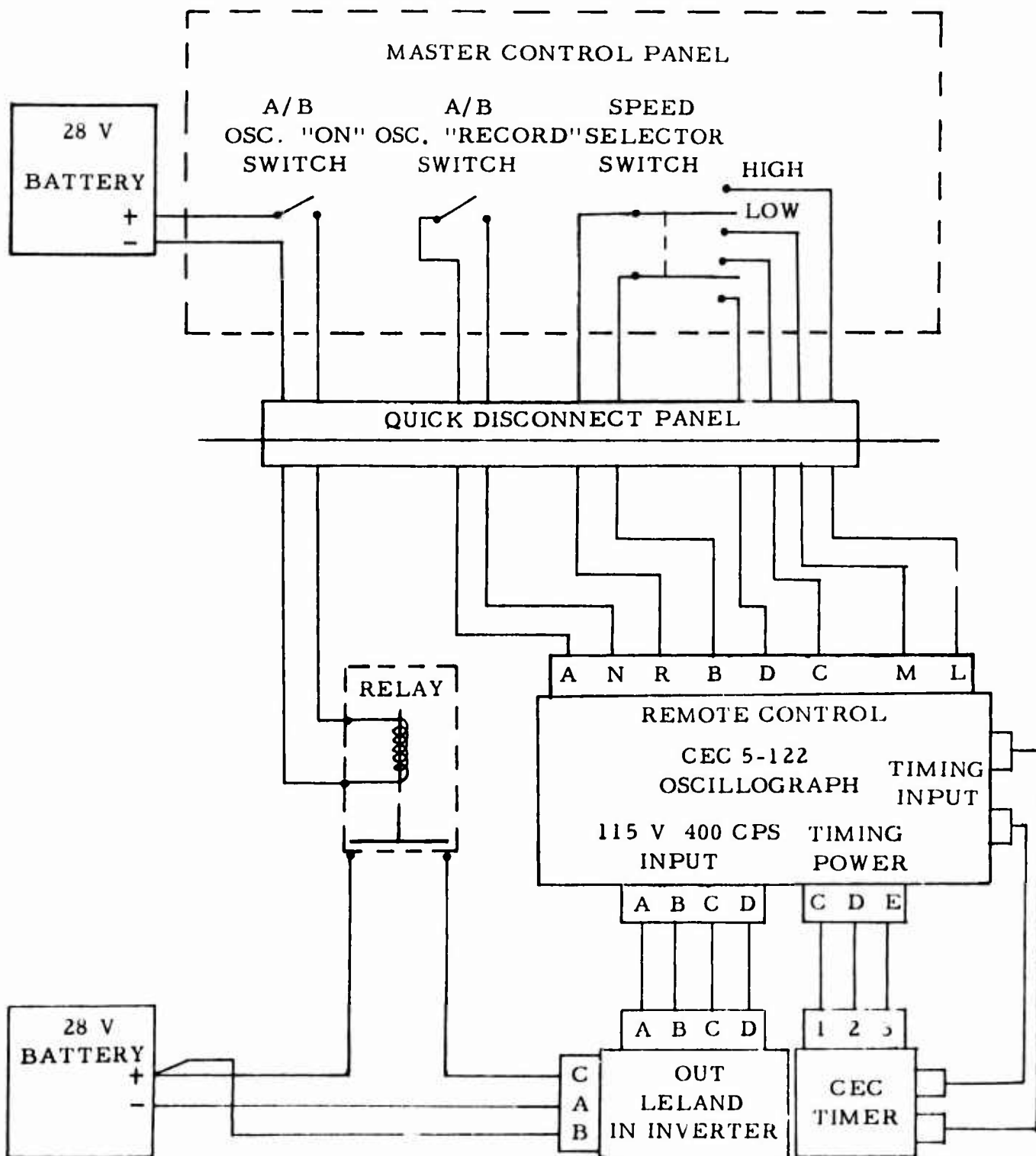

Figure 21. CEC 5-122 Oscillograph Control Unit

- (3) Airborne High-Speed Cameras - The 50V DC power for the operation of the four Photosonics high-speed cameras was taken from two 30V series connected batteries installed in the aft section of the helicopter. The cameras were actuated by a switch on the master control panel which closed a relay in the helicopter. This relay was held closed for a period of 7 seconds by a delay circuit. This precaution was taken to insure complete runout of the film, had the quick disconnect panel been disconnected. A schematic of the high-speed camera control circuit and the seven-second delay circuit is presented as Figures 22 and 23.
- (4) Airborne Low-Speed Cameras - The 28V DC power for the operation of the two Bell & Howell gunsight cameras was provided by the 30V battery used to power the Leland inverter. The cameras were actuated by the same switch on the master control panel that actuated the airborne high-speed cameras. A schematic of the low-speed camera circuit is presented as Figure 22.
- (5) Ground High-Speed Cameras - The 28V DC power for operation of the four Fairchild Model HS-100 high-speed cameras was provided by an aircraft auxiliary power unit. The cameras were actuated by a switch on the ground camera master control box. A 115V, 60 cps signal from a portable power generator was recorded on the film by using a flashing neon bulb inside the camera. This timing signal was used in determining the film speed of the cameras. A schematic of the ground camera control circuit is presented as Figure 24.

c. Event Correlation Circuit

An impact switch mounted on the left landing gear was used to provide an event correlation signal to the three oscillographs and a firing voltage for three flashbulbs. One flashbulb was attached to the chest of the pilot in the field of view of cameras 1A and 2A. The second flashbulb was attached to the right side of the passenger dummy's head in the field of view of cameras 3A and 4A. The remaining flashbulb was attached to the forward rotor housing in the field of view of all the ground cameras. The signal from the switch simultaneously fired the flashbulbs and recorded a blip on all three oscillograph records. A schematic of the event correlations circuit is presented as Figure 25.

d. Oscillograph and Airborne Camera Timing

A 60 cps signal from the 2.5 KW generator mounted on the drop crane was recorded simultaneously on each oscillograph record and on the film in all airborne high-speed cameras. This trace was used to correlate data between the oscillograph records and the film. A schematic of the timing circuit is presented as Figure 26.

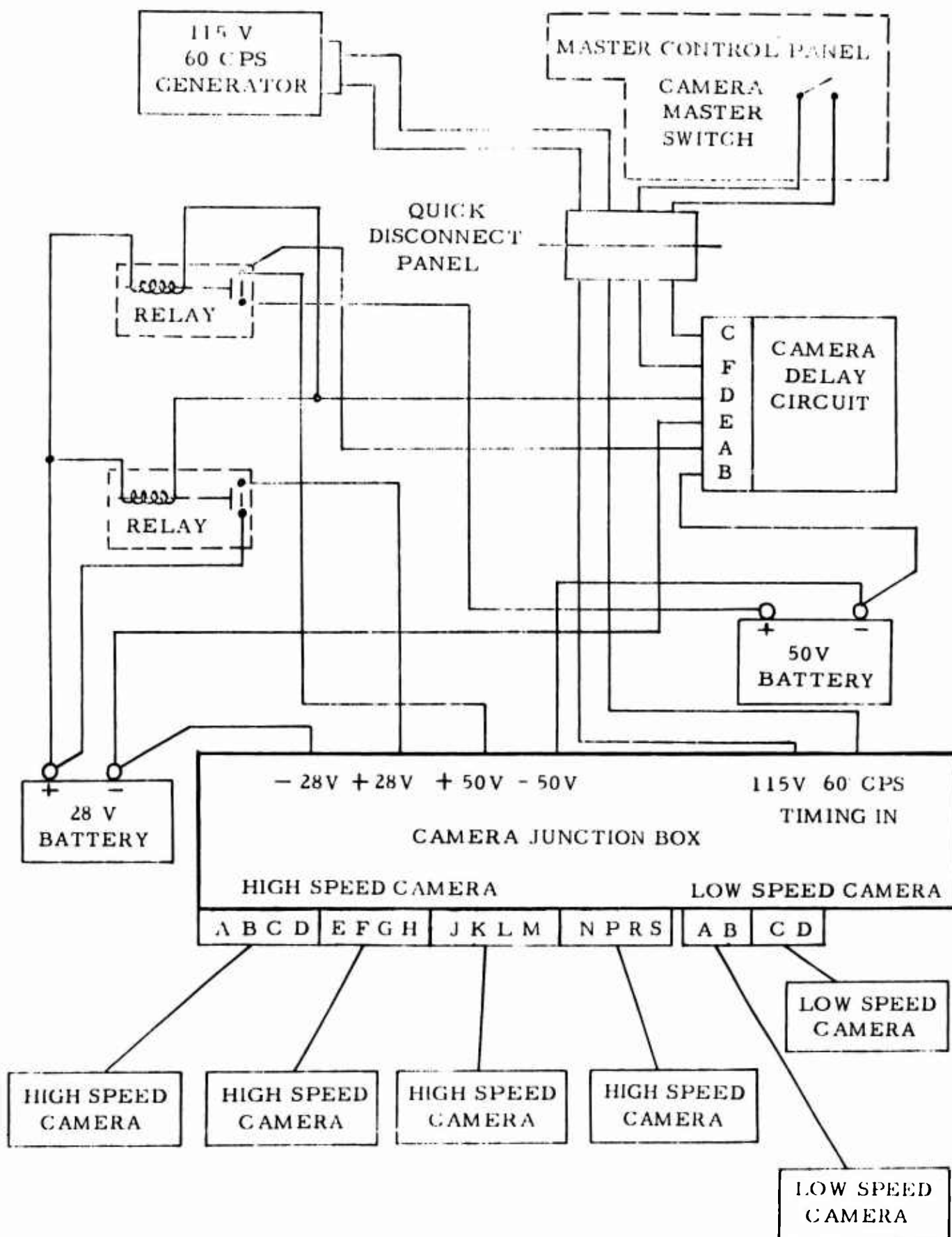
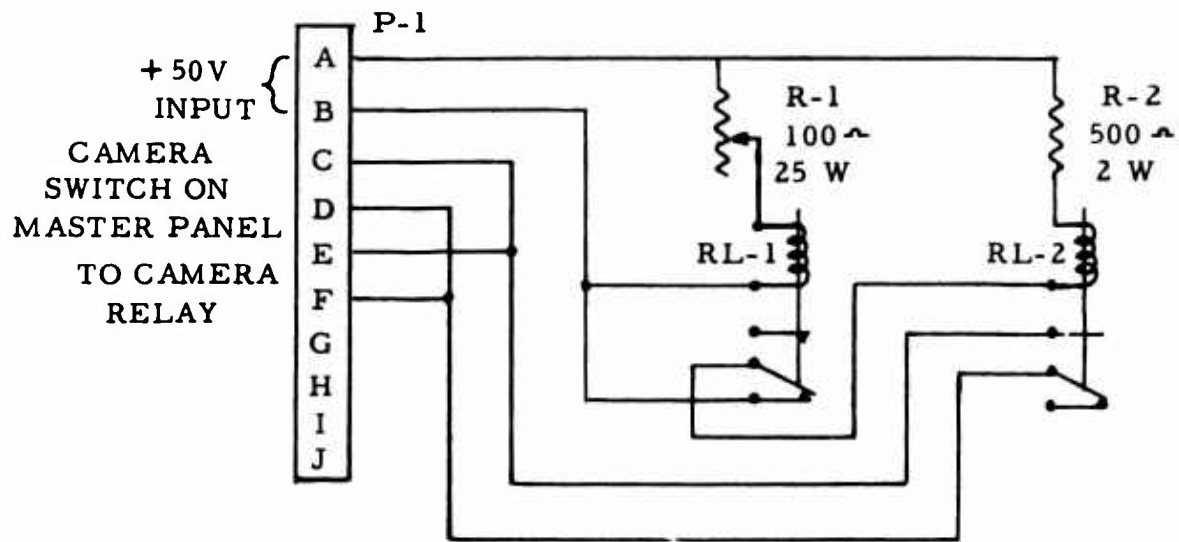

Figure 22. Airborne Camera Control Circuit



NOTE:

R-1 IS ADJUSTED FOR
A SEVEN SECOND ACTION
OF DELAY RELAY RL-1

PARTS REQUIRED

- RL-1 RM-20 DELAY RELAY
- RL-2 CVC 6040 RELAY
- R - 1 100 Ω 25W ADJ. WIREWOUND RESISTOR
- R - 2 500 Ω 2 W FIXED RESISTOR
- P - 1 CONNECTOR - AN 3100A-18-1P

Figure 23. Camera Delay Circuit

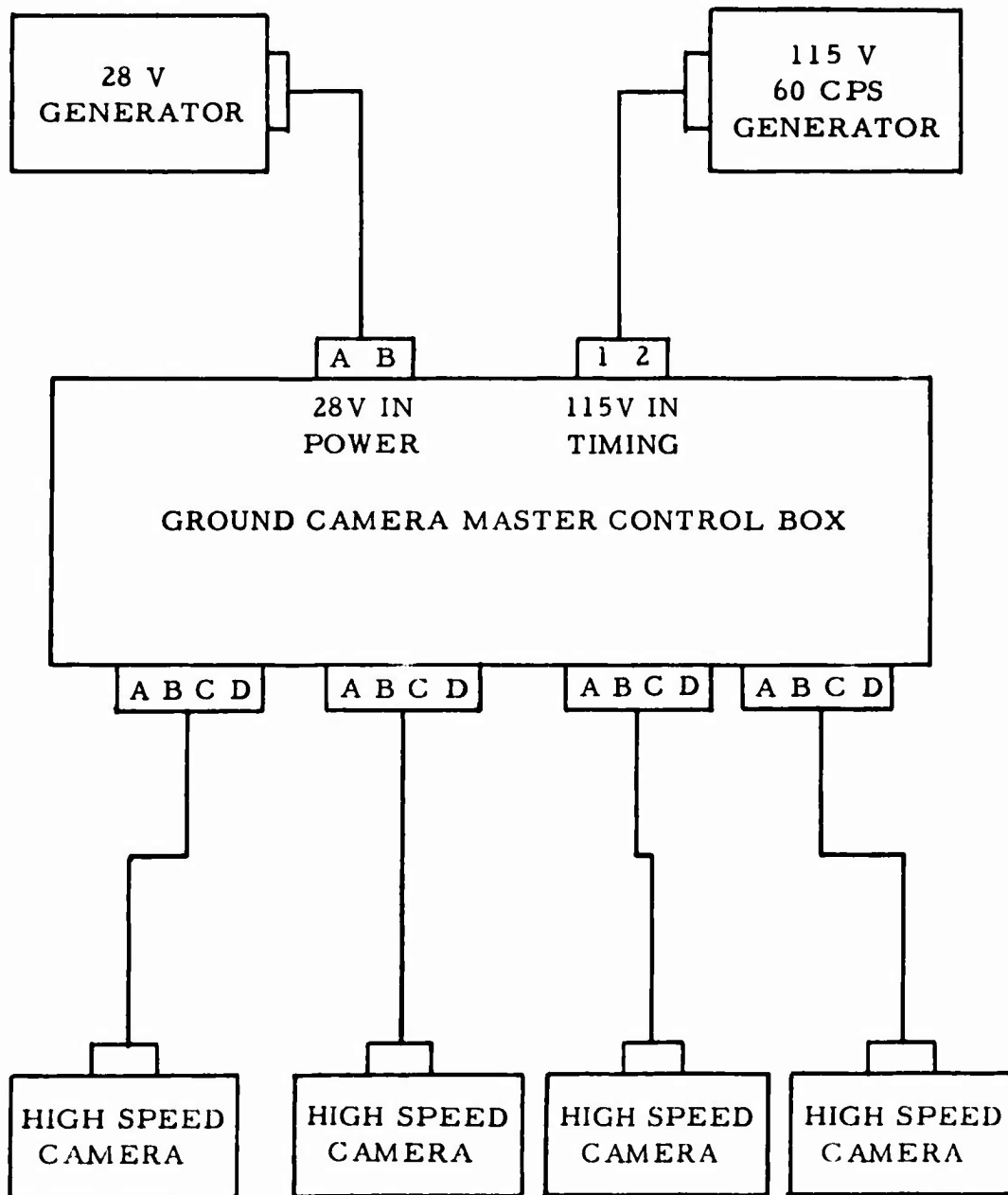

Figure 24. Ground Camera Control Circuit

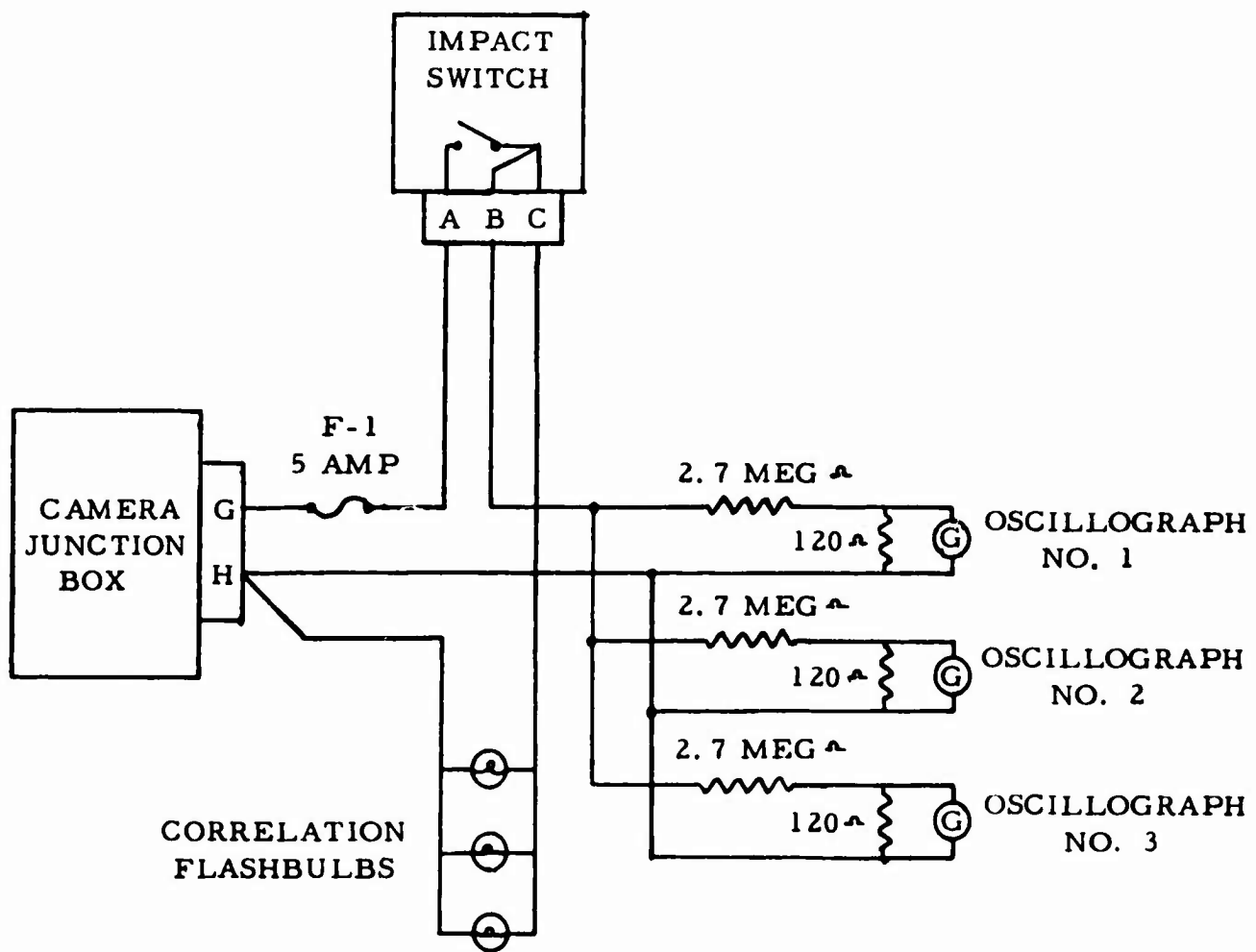

Figure 25. Event Correlation Circuit

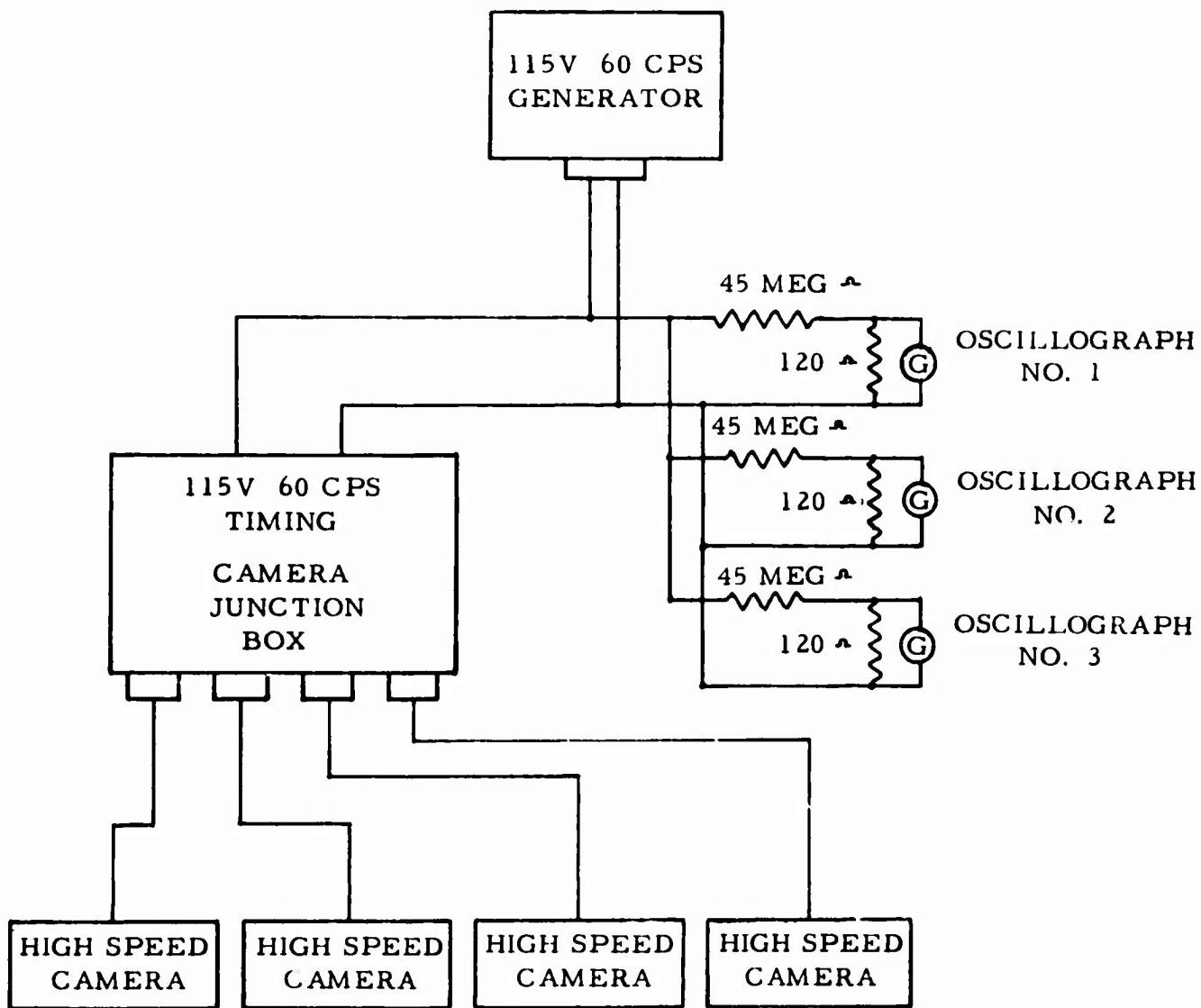

Figure 26. Oscillograph and Airborne Camera Reference Timing Circuit

e. Oscillograph Calibration Circuit

Just prior to and immediately after the crash drop of the helicopter, an automatic resistance calibration was made for all channels of the oscillograph recording system. This calibration was accomplished by utilizing a Chance Vought -designed automatic calibrator which applies known voltage of the same orders of magnitude as those obtained by straining the gages of the bridges. This voltage is obtained by shunting one arm of the bridge with precision resistors.

The calibrator provides a range selection of a high or low sensitivity calibration range for high or low sensitivity bridges. It also provides a sensitivity adjustment and a method of electrically balancing the bridge for zero output for zero load. The calibration circuit theory will be discussed in more detail later in this report under Calibration Techniques, Appendix C. A simplified schematic of the calibrator circuit is presented as Figure 27.

f. Release Hook Circuit

The 24V DC power for operation of the solenoid valves on the release hook was provided by a 24-volt battery mounted on the crane. The release hook actuation was started by a microswitch mounted on the left side of the crane. The microswitch was held open by a lever arm until the crane reached a predetermined point at which time the lever arm engaged a vertical post and closed the microswitch. The microswitch closed a relay which actuated the drop solenoid through a safety switch and two contacts on an oscillograph "on" relay. The purpose of the oscillograph "on" relay was to prevent the release of the helicopter if for some reason the airborne oscillograph had stopped. At a point 100 feet before reaching the vertical post, the crane operator armed the two safety switches. A jettison switch was provided on the crane master control box for emergency operation of the release hook. A schematic of the release hook circuit is presented as Figure 28.

6. Shock Mounting of Airborne Instrumentation Package

Since proper operation of the airborne oscillograph, timer, and inverter could not be guaranteed at accelerations exceeding 15G's, it was necessary to shock-mount this equipment. The container designed to house this equipment included styrofoam packing up to 4 inches thick around the equipment to protect it in case of failure of the energy absorption system. Energy absorption devices, capable of reducing the "G" loading on the equipment to the acceptable 15G limit, were designed using Dow styrofoam, density 2 pounds per cubic foot, as the energy

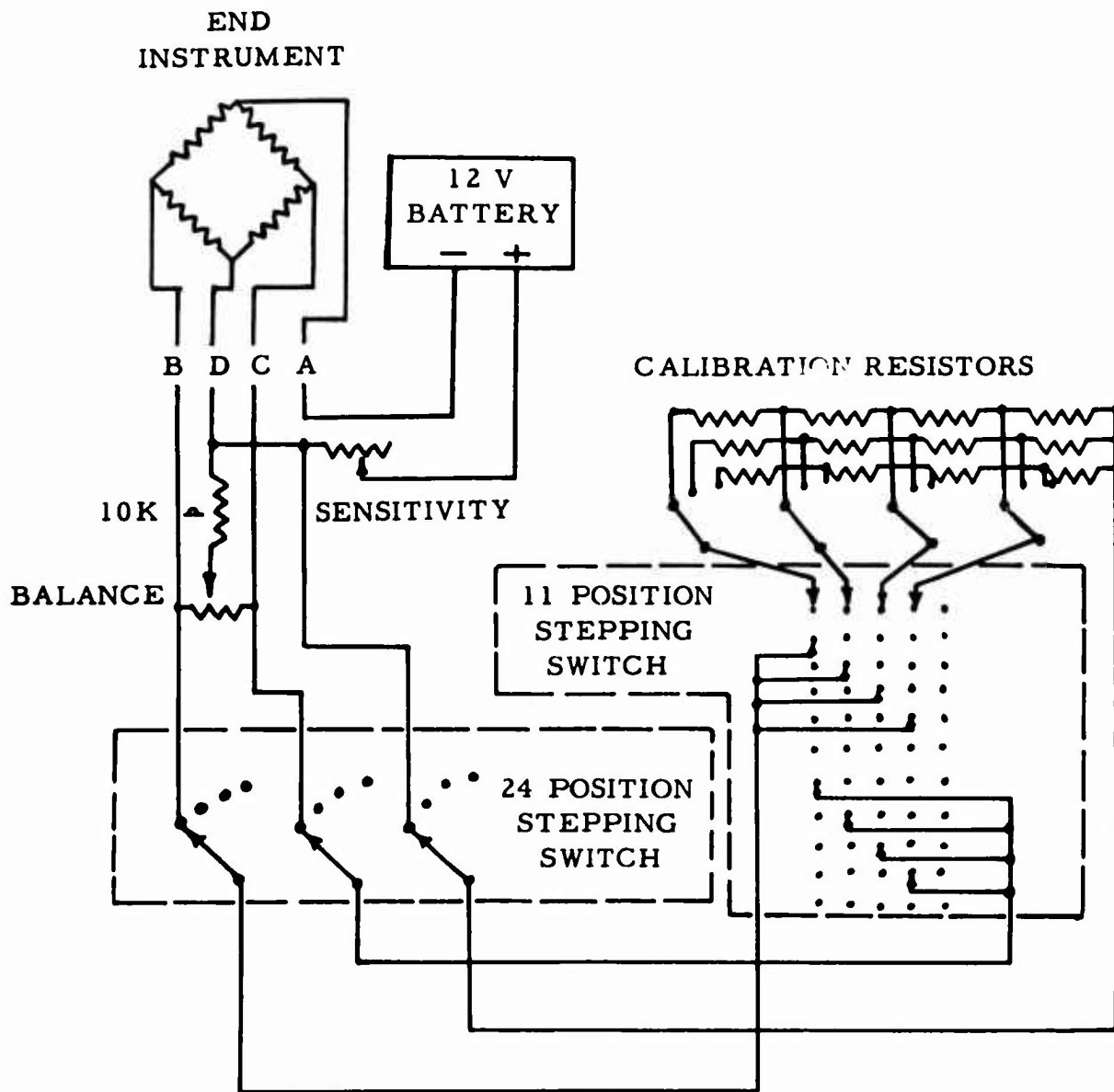

Figure 27. Simplified Calibrator Circuit

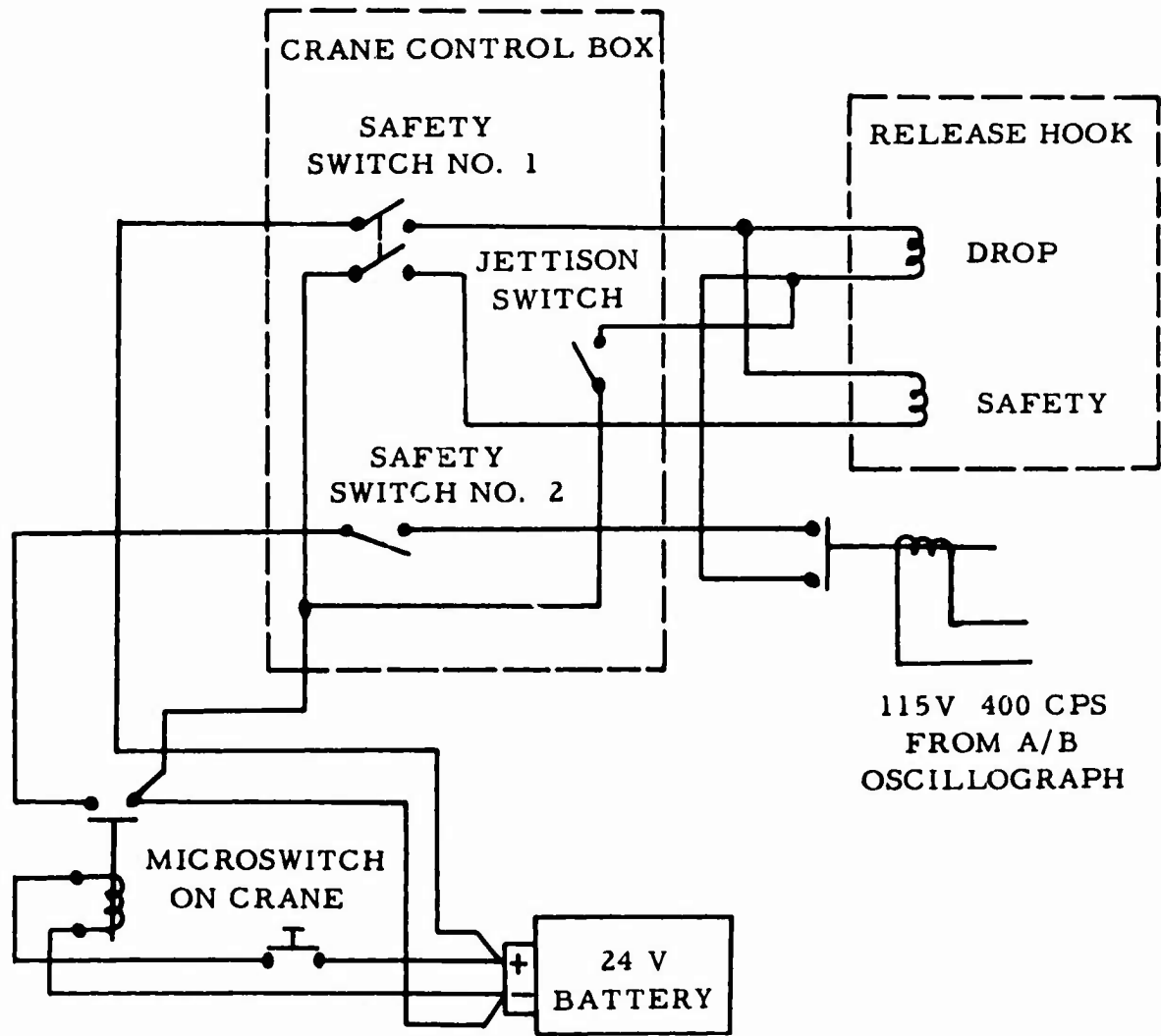

Figure 28. Release Hook Circuit

absorption material. Since space within the helicopter was limited, a 5:1 pulley arrangement was used to reduce the size of the styrofoam block required.

A package containing dummy electronic equipment was drop-tested at Chance Vought to the required terminal velocity during development of the optimum energy absorption device. The final drop included the installation of a complete instrumentation package in order to observe the operation and recording ability of this equipment during the period of high deceleration anticipated in the crash.

Two separate energy absorption devices were installed in the helicopter for the crash tests. The vertical shock device limiting the maximum loading to the electronic package to 12.0G's was mounted externally on top of the helicopter. The longitudinal shock device limiting the maximum loading to the electronic package to 8.0G was mounted in the helicopter on the shelf above the main fuel cell. The resultant design loading on the electronic package from the simultaneous loading of the two devices was 14.5G.

A photograph showing the energy absorption design, typical for both the vertical and longitudinal systems, is presented in Figure 29.

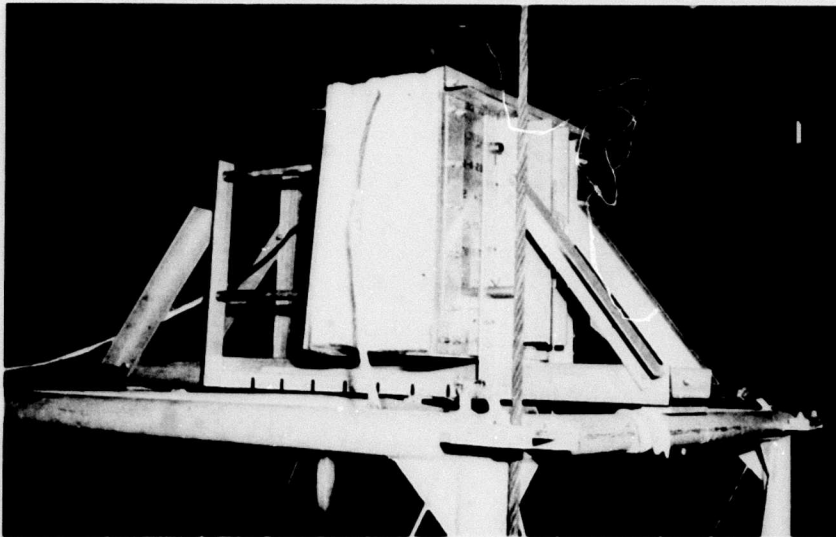

Figure 29. View of FSF Oscillograph Shock-Mount Test Showing Energy Absorption Device After Drop

A view showing the vertical device installed in the helicopter is presented in Figure 5. A comprehensive presentation of the design, development, testing, installation, and function of the shock devices and airborne oscillograph during the test is given in Appendix B.

TEST PROCEDURE

A. PRE-CRASH TESTS

1. Log Drop Tests

Tests were made to determine the ability of the drop crane to transport the helicopter at the required speed and drop it in the desired target area. The tests were made using a 6,000-pound bundle of logs to simulate the mass of the helicopter. The following items were observed during the tests:

- a. The acceleration and maximum speed of the crane;
- b. Stability of the suspended mass during the run;
- c. Function of the automatic triggering device and release hook;
- d. Ability to drop the mass at the desired point;
- e. Functioning of the umbilical cable pay-out system; and
- f. Ability of the crane to decelerate the load in event of a failure of the release system.

2. Check Drop

Prior to the actual crash drop, two drops of the helicopter were made from a height of 6 inches to check the proper function of the electronic equipment. Test shots were made of the on-board cameras during the first of these drops.

Results of the pre-crash tests are presented on pages 45 to 47 of this report. A photograph showing the logs in position for a test run is presented in Figure 30.

B. CRASH TEST

After the final pre-drop servicing of the landing gear tires and shock struts had been completed and the final instrumentation check-out had been approved, the helicopter was hoisted into position on the crane boom. The runway in the immediate target area was swept free of dust a few minutes prior to the crash.

The crane run commenced some 4,000 feet from the impact point so that the crane would have sufficient running distance to reach the required speed. Flags were placed on each side of the runway 100 feet

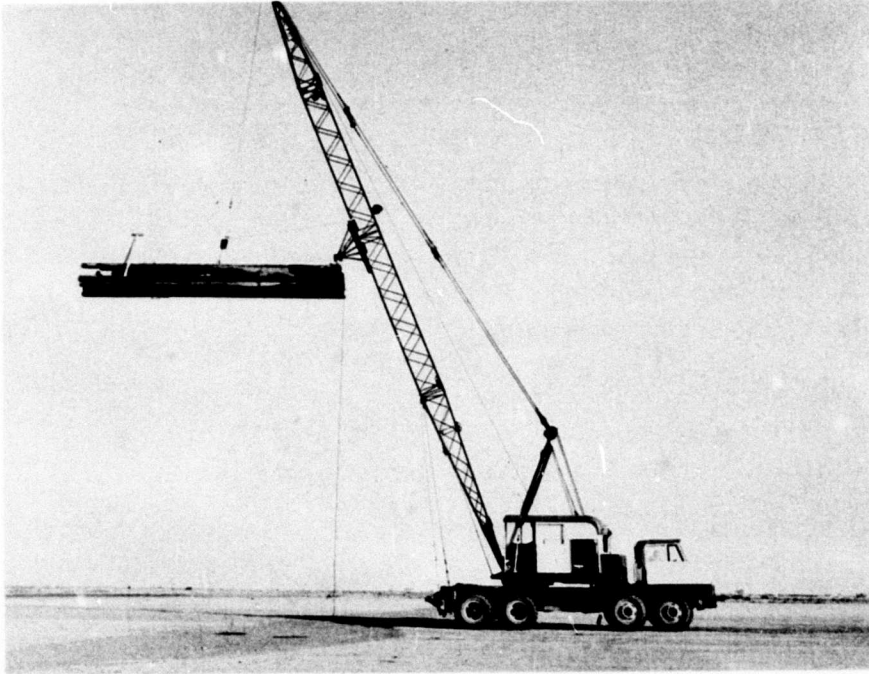

Figure 30. Log Drop Test Set-Up

prior to the release point to signal the operator to switch on the instrumentation equipment and energize the release hook safety 2 seconds prior to the drop. The release hook was triggered at the instant of contact of the arm of the automatic triggering device with the stationary ground pole located 54 feet behind the impact point.

The fall and impact of the helicopter was recorded by high-speed movie cameras installed in the helicopter and on the ground. Crash forces were recorded, through instrumentation installed with the helicopter, by recording oscillographs installed onboard the helicopter, and on the ground.

A photograph showing the helicopter hoisted into position on the crane boom and ready for the crash run is presented in Figure 4.

TEST RESULTS

A. PRE-CRASH TESTS

1. Moving Crane and Log Drop Tests

Tests were conducted using the 6,000-pound bundle of logs to simulate the mass of the helicopter during preliminary design of the test set-up and again two days prior to the actual crash date. The following results were obtained from these tests:

a. Preliminary Test

- (1) This test was conducted at Williams Air Force Base, Arizona, on 13 September 1960 with both unloaded and loaded crane runs made. A maximum speed of 28 miles per hour was obtained in a 1,600-foot running distance with the unloaded crane. The loaded crane reached a maximum speed of 25 miles per hour in the same distance.
- (2) The stability of the crane and the suspended mass during these runs was very good. A smooth runway surface had been selected and the pitch, yaw, and roll stabilization devices functioned well.
- (3) During the first run in which the mass was to be dropped, malfunction of the electric release hook occurred. An adjustment was made, consisting of moving the load point toward the load support arm hinge of the hook and away from the release end. This reduced the load on the overloaded solenoid and enabled the hook to release during the test run.
- (4) The mass was dropped within 3 feet of the desired location. After ground contact, the mass moved forward a distance of approximately 10 feet. A total of four movie cameras located on the ground at the drop site recorded the test.

As a result of this test, it was concluded that this test method was entirely acceptable. However, the H-34 release hook was to be replaced with the larger (10,000-pound capacity) H-37 electric release hook. It also was decided to obtain a greater length runway in order to increase the maximum speed of the crane to the required 35 miles per hour. The Goodyear Auxiliary Airstrip, 18 miles southwest of Williams Air Force Base, was chosen because of an available 4,000-foot smooth runway surface.

b. Final Test

Two runs were made on 20 October 1960 at the Goodyear Airstrip. The set-up was the same as in the preliminary test, and the behavior of the crane and suspended log mass was again very good. The crane reached a maximum speed of 30 miles per hour in the 4,000-foot running distance. On the second run the mass was dropped at the desired location with the automatic triggering device and the Chance Vought pneumatic release hook functioning properly.

2. Check-Drop No. 1

On October 19 the first stationary check-drop was attempted but the H-37 electric release hook failed to release the helicopter load. The hook had been checked out on a work bench prior to installation on the helicopter and would release under no load. An attempt to release the helicopter using the hook mechanical release also failed.

On the following day two Army hook-experts were called in to make the hook operative. Their examination revealed that the hook would have to be completely disassembled in their shop since the trouble lay in the inaccessible inner mechanism.

In order to save time and have a spare should the hook not be made operable, a Chance Vought manually operated release hook was equipped with 3,000 psi pneumatic cylinders to actuate the release hook safety and quick release lever through an electrically operated remote control system. The hook was tested prior to shipment to Phoenix by lifting an 11,500-pound load at Chance Vought. The hook was able to release the load satisfactorily at pressures as low as 300 psi. A photograph showing the hook details is presented as Figure 31.

The pneumatic hook was installed on the helicopter lift system and the check-drop made with the vehicle in a 3-point landing attitude. This 6-inch free-fall drop introduced a load to the helicopter structure of approximately 75 percent design limit landing load. During this drop, the cameras and instrumentation system functioned properly with good oscillograph records obtained.

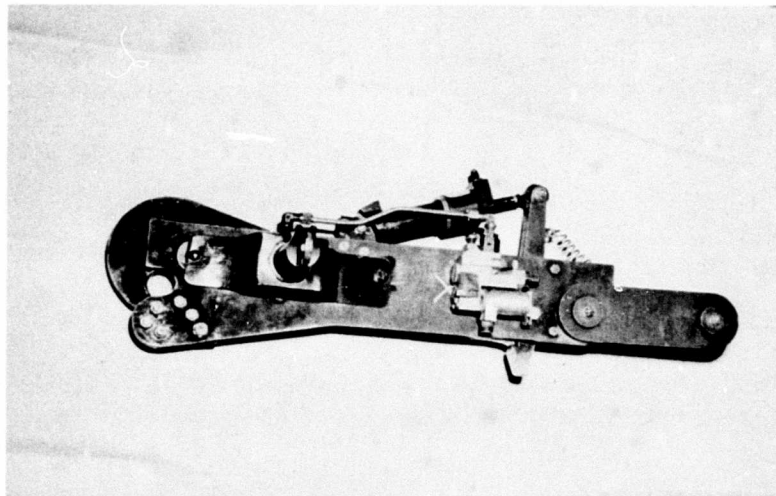

Figure 31. Chance Vought Aeronautics Pneumatic Release Hook

3. Check-Drop No. 2

This stationary drop was made during the morning of 22 October 1960 preceding the actual crash that afternoon. The drop was made as a final check of the complete instrumentation system which had now been installed on the crane deck and also to check the function of the automatic triggering device and pneumatic release hook. The complete system functioned satisfactorily indicating that the helicopter was ready for the final crash drop.

B. CRASH TEST

1. General

The actual crash drop was made at 1615 MST on 22 October 1960. The weather was fair except for a thin scattering of cirrus clouds which intermittently affected sunlight intensity. The temperature was approximately 80 degrees F. A cross-wind of approximately 5 knots was observed.

During the 4,000-foot final run, the crane accelerated smoothly to a maximum speed of 30 miles per hour as in the previous log test run. The suspended helicopter was observed to be slightly swaying as it neared the target area. The center of the helicopter impacted at a point 2 feet to right and 3 feet forward of target dead center. During the free fall, the vehicle was observed to roll slightly to the left and yaw to the left; the roll angle measured approximately 6 degrees, the yaw angle approximately 5 degrees at ground contact. There was no pitching of the vehicle. The helicopter moved forward after ground

contact a distance of 16 feet.

A post-crash examination was made to observe the extent of damage to the vehicle and injury to its occupants. The following observations were made:

a. Helicopter Structure

At ground contact, the soft fuselage structure was pushed in by the stiffer landing gear, causing considerable distortion to the fuselage around the gear. The outer shell of the helicopter did not greatly distort except on the underside; however, there were a number of skin penetrations and breaks.

b. Pilot

The pilot seat support structure collapsed and the dummy pilot's head struck the fuselage frame on the left hand side of the cockpit violently enough to split his helmet visor. It was evident that very high vertical forces were also encountered by this dummy.

c. Passenger

The troop seat collapsed in such a manner that the passenger dummy was thrown forward and downward, his head contacting the rear of the pilot's seat.

d. Range Extender Fuel Tank

The copilot seat support structure failed, causing the seat to move forward. The range extender fuel tank located in this seat contacted the structure causing the cell to tear with its fuel (colored water) spilling over a large area.

e. Airborne Oscillograph Recording System

Examination of the airborne instrumentation recording system following the crash found this equipment to be operable. The shock absorption devices had functioned to properly protect the equipment and allow its operation during the test.

f. Airborne Cameras

No damage was suffered by the airborne cameras; however, the inside side camera viewing the passenger dummy was ripped from its mounting due to collapse of fuselage structure at this location. The protective container housing this camera shielded it from damage.

Photographs showing post-crash views of the pilot, passenger, range extender fuel tank, and helicopter structure are presented as Figures 32 through 37.

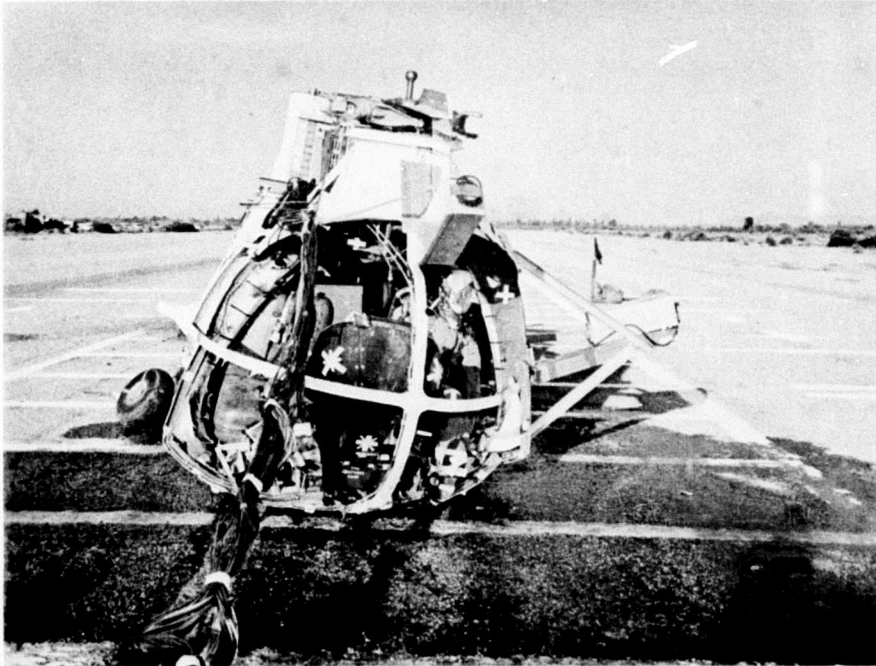

Figure 32. Post-Crash Front View

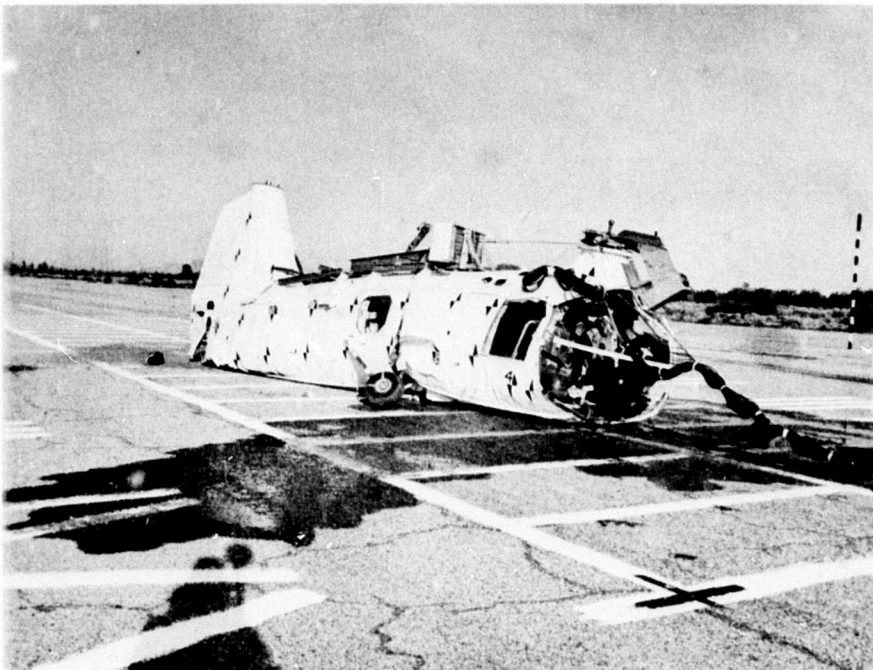

Figure 33. Post-Crash Front Quarter View

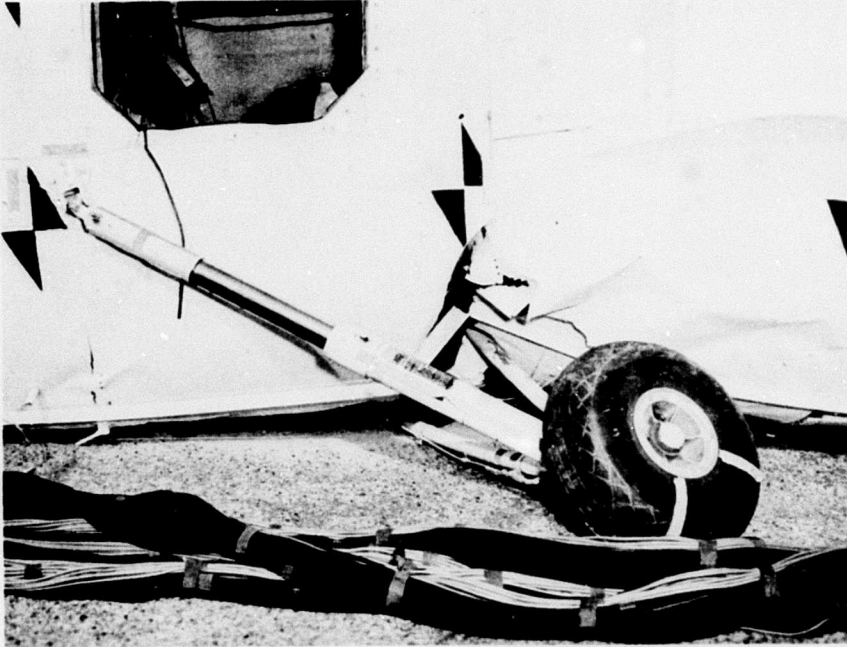

Figure 34. Post-Crash
View of Right Main
Landing Gear

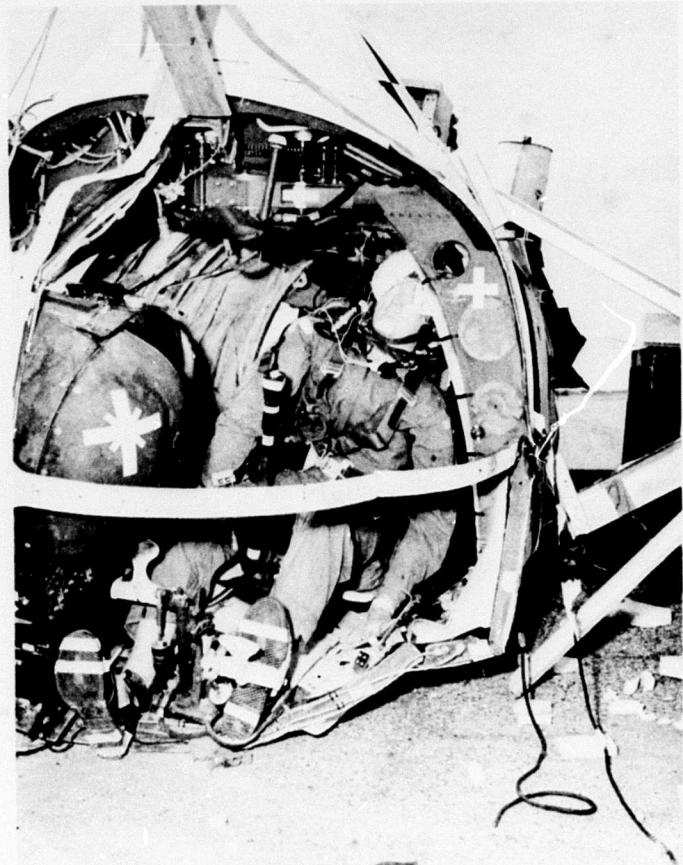

Figure 35. Post-Crash View of
Dummy Pilot

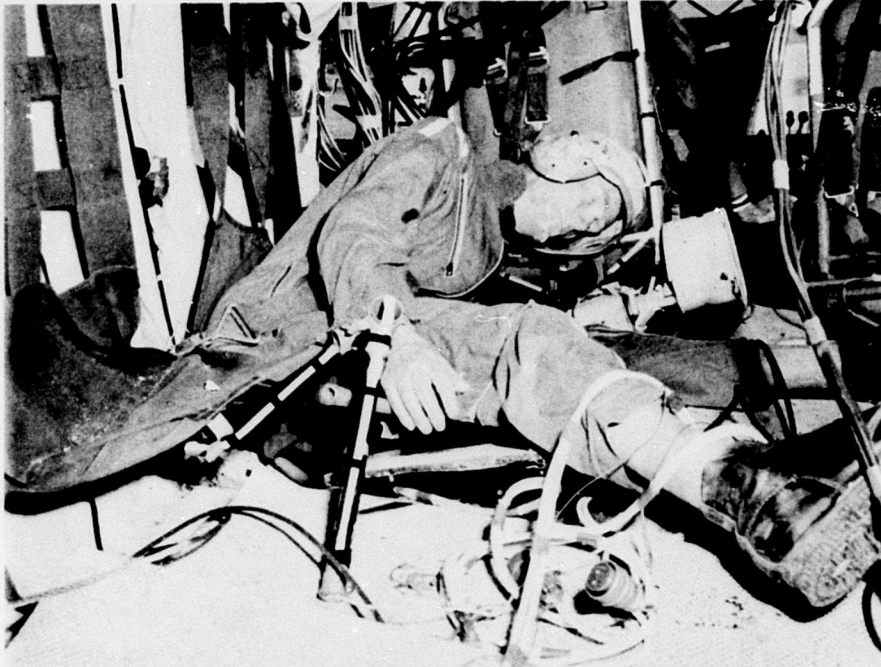

Figure 36. Post-Crash View of Dummy Passenger.



Figure 37. Post-Crash Damage to Range Extender Fuel Tank

2. Measurements

a. General

Results from the recording systems varied from excellent on the airborne and ground oscillograph records to good and moderate on the photographic recording systems.

The record taken from oscillograph No. 1 is shown in Figure 38 and is typical. The individual traces from these records have been separated and are being analyzed as discussed in a later section of this report. The sign conventions used for acceleration are shown in Figure 39. Acceleration sign conventions for the passenger dummy are referenced to the dummy and not to the airframe.

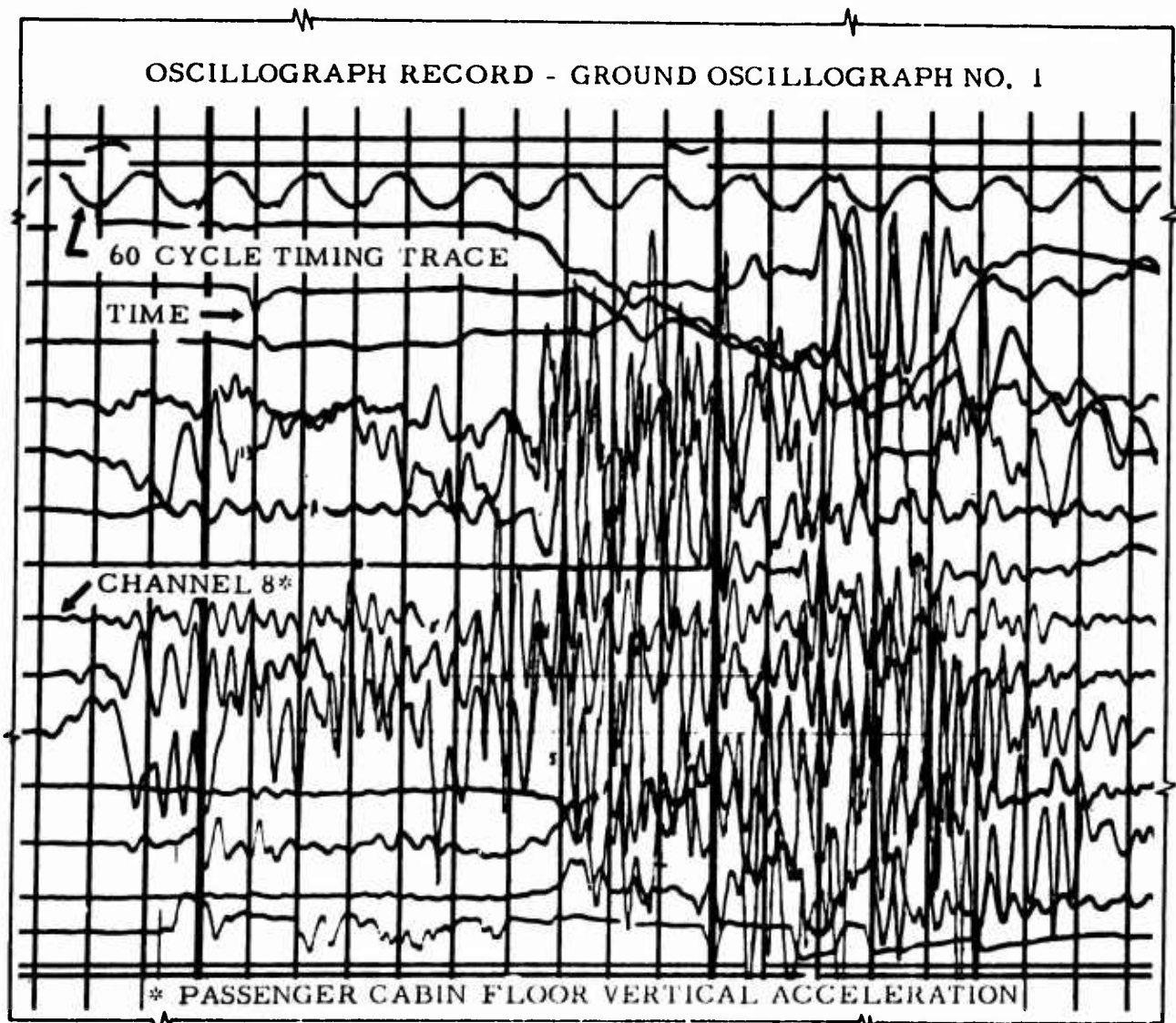

Figure 38. Oscillograph Record - Ground Oscillograph No. 1

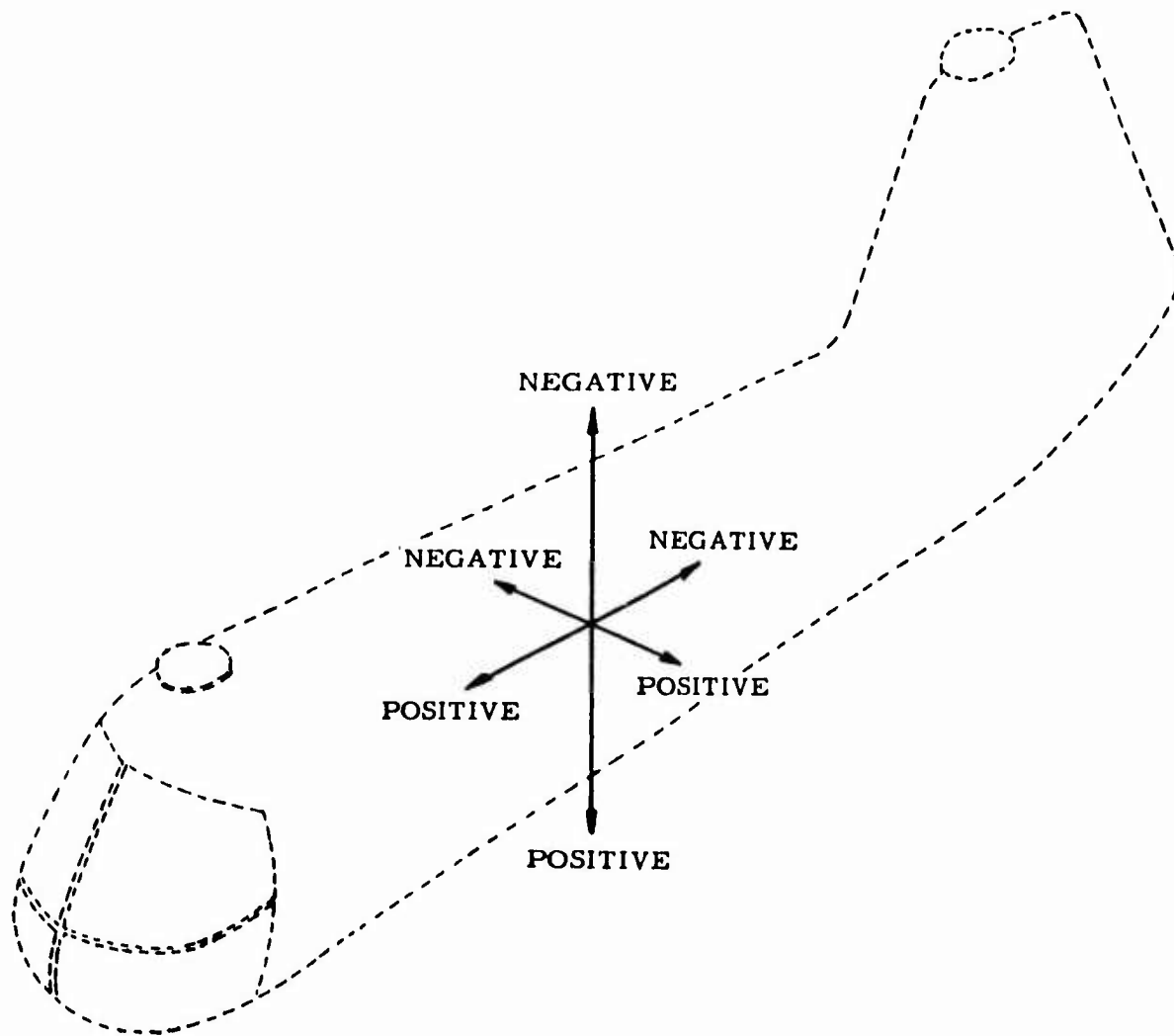

Figure 39. Accelerometer Data Sign Convention

Data reduction techniques applied to the instrumentation measurements are presented in Appendix C.

b. Operation of Equipment During Test

(1) Airborne Oscillograph

The CEC-5-122 oscillograph installed in the helicopter functioned and recorded data during the crash. At approximately 0.46 second after impact, the voltage input to the oscillograph dropped momentarily causing the record relay to drop out. This resulted in a blank space approximately 6 inches long on the record. All pertinent action had previously taken place, however,

so that no important data was lost by this malfunction. The 100 cps section of the timer was inoperative during the run. The 60 cps reference was good, however, enabling the correlation of the record with the ground oscillograph. This was accomplished using the timing lines on the ground oscillograph as the standard time base. No other malfunction was noted for the remainder of the event. A post-crash calibration was made and recorded without difficulty. The quality of the record was excellent making trace identification easier than had been anticipated. However, as in Figure 38, there was evidence of overcrowding, some traces being difficult to identify in a few portions of the record.

(2) Ground Oscillographs

The two CEC 5-114 oscillographs, installed on the rear deck of the drop crane, functioned properly throughout the test. A post-crash calibration was made on all channels without difficulty. The quality of both records was excellent with almost no loss of data through the entire recording period.

(3) Airborne Cameras

- (a) Camera 1A (High Speed Photosonics Camera mounted externally to the front of the helicopter providing a front view of the dummy pilot and range extender fuel tank) - The camera functioned properly throughout the test producing color film of good quality.
- (b) Camera 2A (High Speed Photosonics Camera mounted externally on the left hand side of the helicopter providing a side view of the dummy pilot and range extender fuel tank) - The camera functioned properly during the test producing color film of good quality. However, some areas contained shadows which were detrimental to the detail desired. The rear mounting support of the camera failed at impact causing the camera to swing forward pivoting about the front mounting support. However, the pilot remained in the field of view throughout the crash period.

- (c) Camera 3A (High Speed Photosonics Camera mounted inside the helicopter facing the dummy passenger) - The camera functioned properly throughout the test; however, the camera support frame broke loose from the helicopter fuselage on impact causing the field of view to change during camera operation. Due to insufficient lighting at this location, the film was of poor quality.
- (d) Camera 4A (High Speed Photosonics Camera mounted to the rear of the cabin providing an over-all view of the helicopter interior) - The camera functioned properly throughout the test. The film was only of fair quality due to insufficient lighting of the helicopter interior. In general, most of the film was underexposed. However, some useful data is being obtained from this film. The field of view of the camera was partially blocked by the movement of the airborne electronic package during the test.
- (e) Cameras 5A and 6A (Bell and Howell Gunsight Cameras mounted to the rear deck and rear cabin floor inside the helicopter) - Both cameras were inoperative during the test. There is good evidence that the malfunction was not electrical since three flashbulbs, connected to the same circuit supplying power to the cameras, fired as planned. Both cameras were completely checked out prior to the drop at which time they functioned normally. Cause of the malfunction is not known.

(4) Ground Cameras

The three high-speed Fairchild Ground Cameras (numbers 7G, 8G, and 9G) functioned normally producing good color film of the entire crash.

The one black and white high-speed Fairchild camera (number 10G) did not record.

BLANK PAGE

DATA REDUCTION AND INTERPRETATION

The reduction and interpretation of the oscillograph data obtained during the H-25 test has been divided into four phases:

- (1) Transcription of the records;
- (2) Attenuation of the "high frequency" components;
- (3) Validation of the records;
- (4) Analysis, interpretation, and correlation with photographic evidence.

Each of these phases must be considered in conjunction with each of the 42 records obtained (34 end instruments with 8 duplicate records).

1. Transcription of Records

Because of the number of channels to be recorded and the limited oscillograph paper width, three oscillographs were required for recording the data, with up to 20 channels (plus two reference traces) being recorded on one oscillograph.

Three steps in transcribing the resultant data were required: (1) separating the closely spaced records; (2) bringing the records from the three oscillographs to a common time-base; and (3) enlarging the records where necessary to permit accurate evaluation of areas under the acceleration time curves. Fortunately, all records were of excellent quality, greatly simplifying the separation of the individual traces. A partial section of one original oscillograph record is shown in Figure 38.

Channel 8, vertical acceleration of the passenger cabin floor, has been extracted from Figure 38 and is shown in Figure 40. A 3X magnification of this trace was used in obtaining the attenuated acceleration curve and the velocity curve also shown in the figure. (Also see Figures 41, 42, and 43.)

2. Attenuation of the High Frequency Components

In acceleration measurements of complex structures, "ringing", or the introduction of various natural frequencies of the structure into the acceleration records, is a constant problem. Often "high frequency components" of very large magnitude are

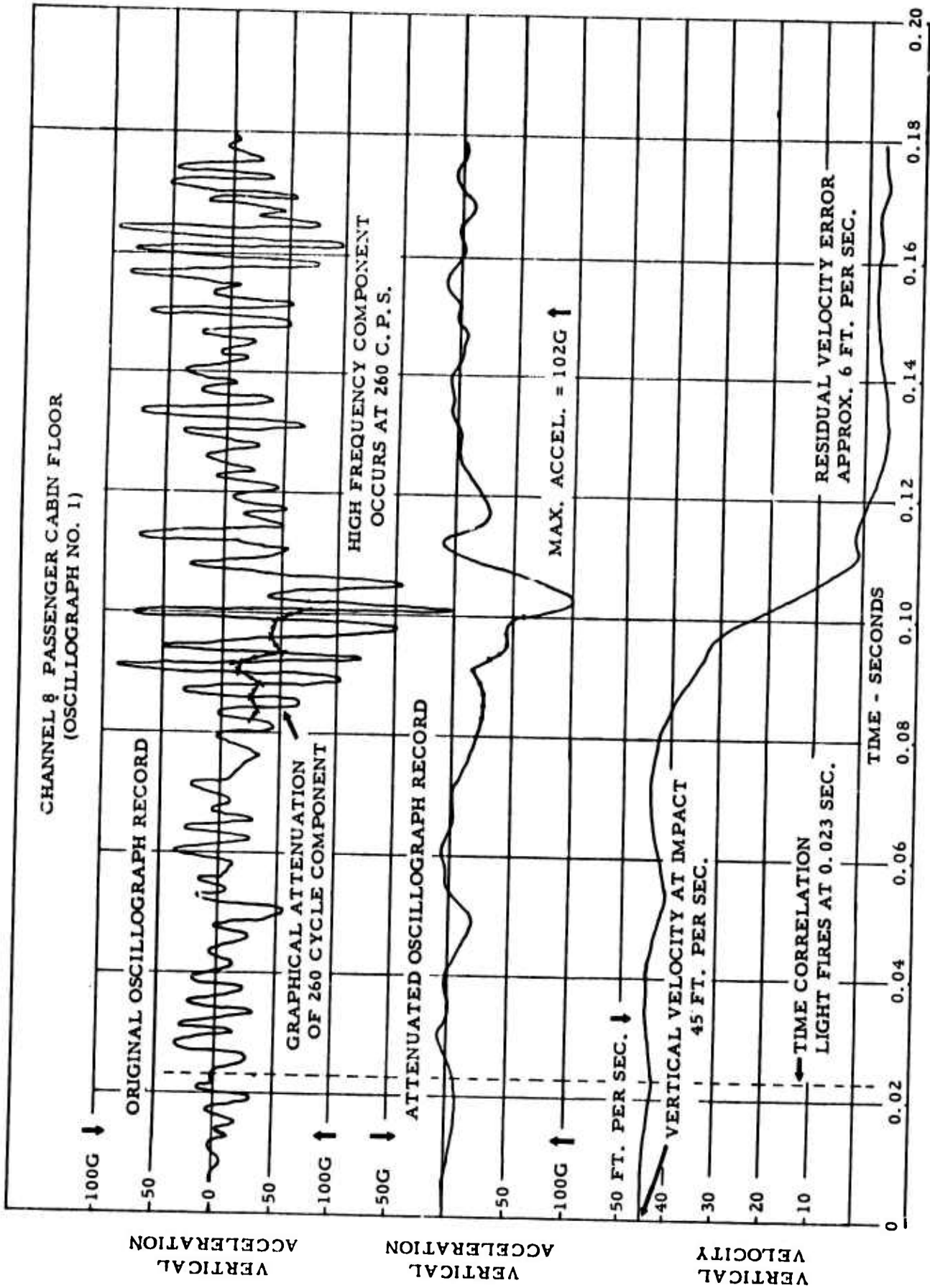

Figure 40. Channel 8-Vertical Acceleration of Passenger Cabin Floor

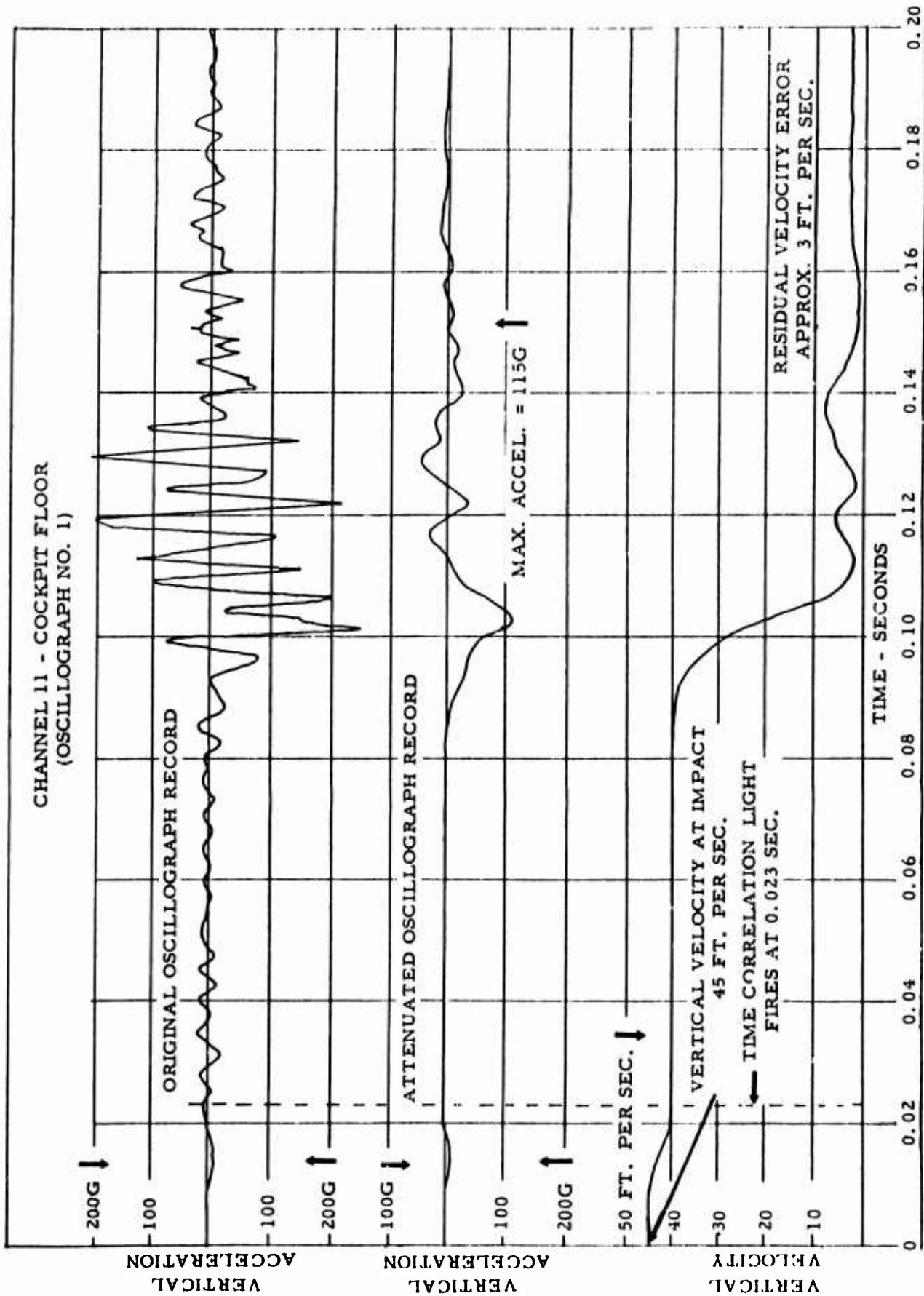

Figure 41. Channel 11-Vertical Acceleration of Cockpit Floor

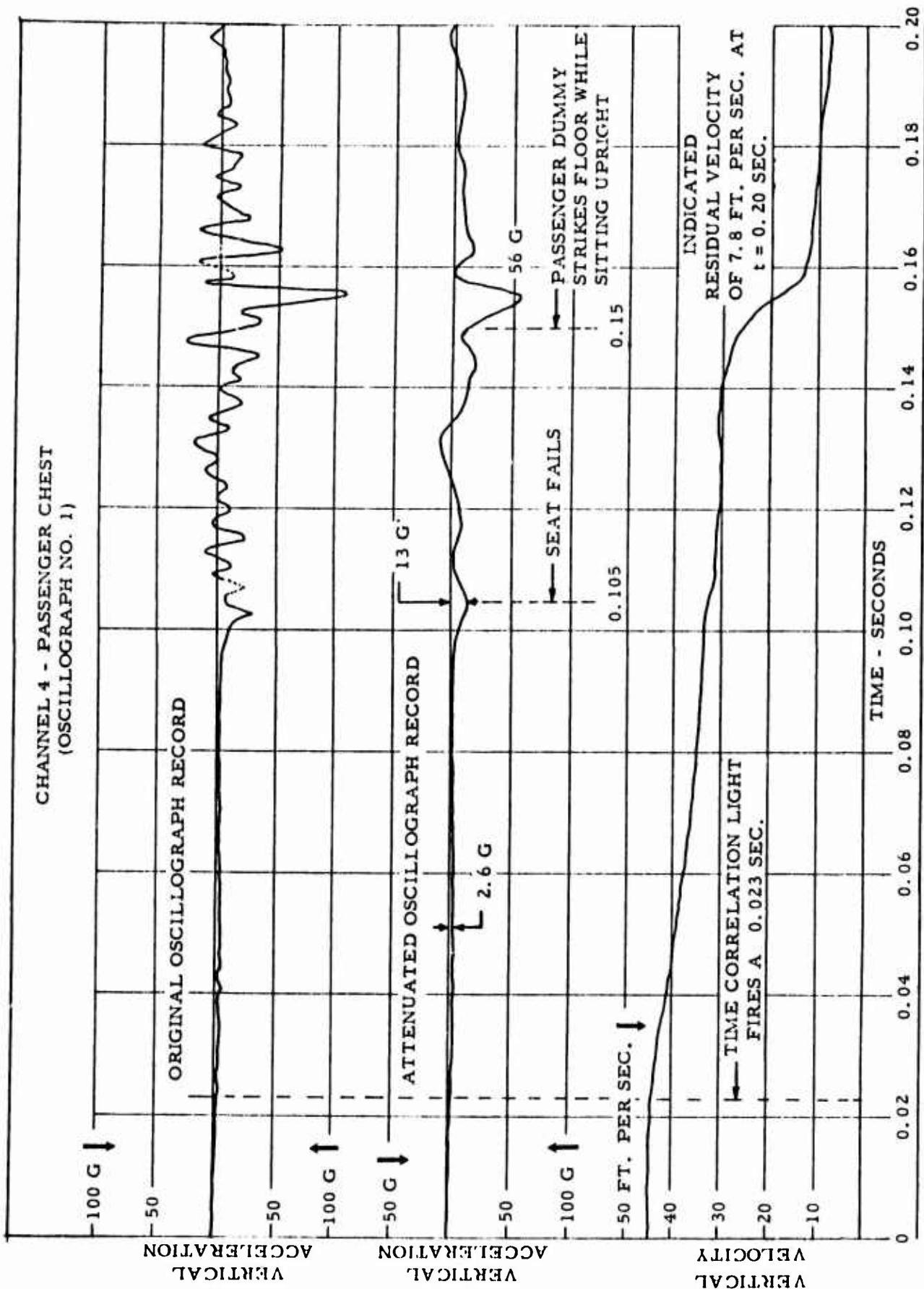

Figure 42. Channel 4-Vertical Acceleration of Passenger Chest

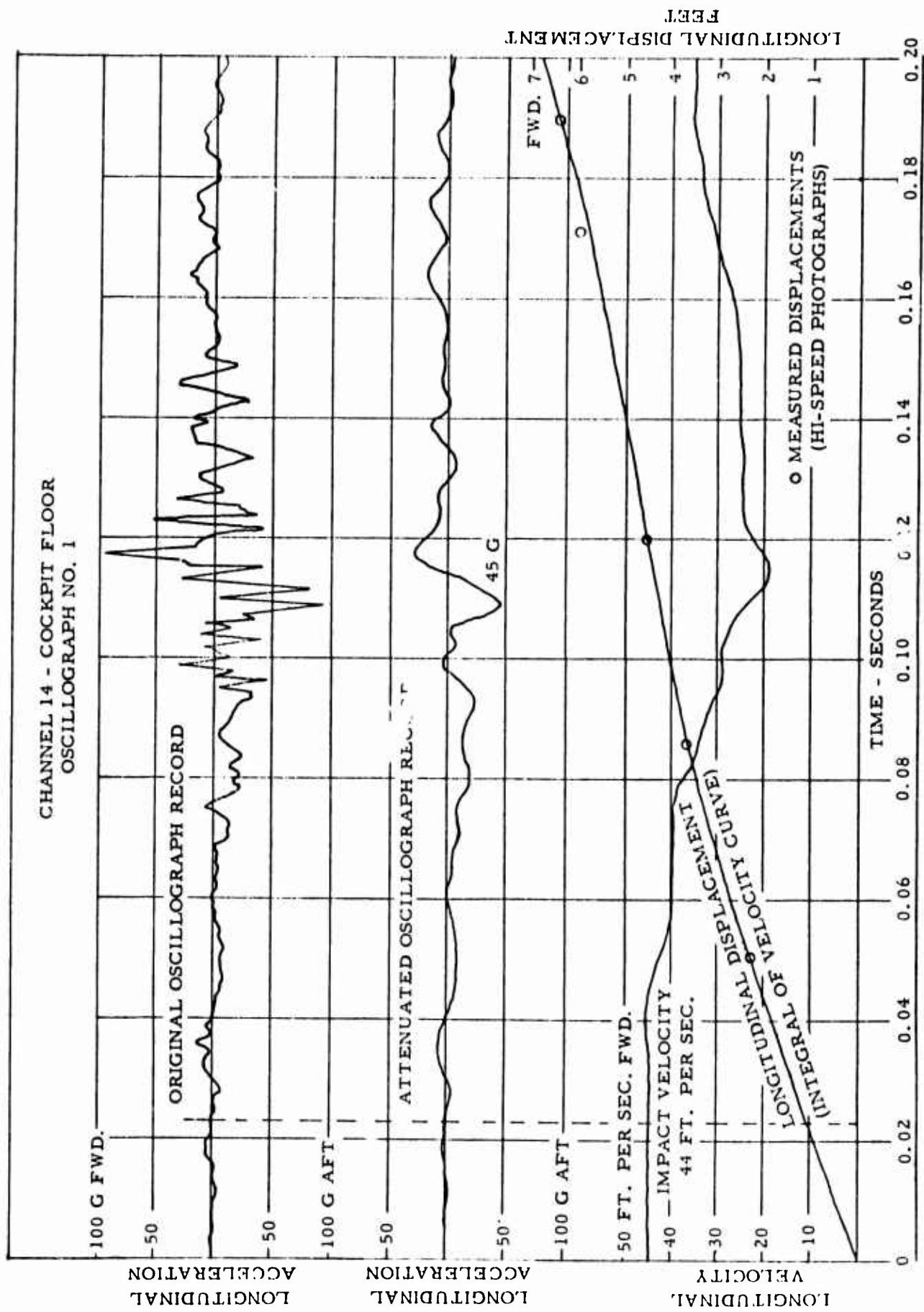

Figure 43. Channel 14-Longitudinal Acceleration of Cockpit Floor

observed. This occurs because of the inherent relation between displacement, acceleration, and frequency in sinusoidal oscillations. To illustrate:

If a point is moving harmonically with displacement "X", given by the equation:

$$X = A \sin \omega t$$

then the acceleration of the point is:

$$a = -\omega^2 A \sin \omega t = -4\pi^2 f^2 A \sin \omega t$$

Where:

A = The amplitude of the oscillation

ω = Circular frequency in radians per sec.

$$f = \frac{\omega}{2\pi} = \text{frequency in cycles per sec.}$$

Thus, "a" can be very large even though "A" is small for large values of "f". For the oscillograph record shown, the 260 cps component gives an acceleration amplitude of 100G for an oscillation with an amplitude of only 0.0145 inch. These high frequency peaks are probably meaningless insofar as inducing possible injury to an occupant of the aircraft, and have been graphically attenuated from the final acceleration-time plot as shown in the attenuated oscillograph record.

3. Validation of the Records

The foregoing method of smoothing the data requires some judgment on the part of the analyst, introducing a possible source of error. However, certain steps can be taken to further check the validity of the final results as follows.

The acceleration-time curves obtained in the test can be integrated and compared with the known change in velocity (or displacement) of the point to which the transducer was attached. For example, from the definition of acceleration:

$$\frac{dv}{dt} = a$$

It follows that:

$$V_2 - V_1 = \int_{v_1}^{v_2} dv = \int_{t_1}^{t_2} a \cdot dt$$

This means that the area under the acceleration-time curve must be equal to the change in velocity.

For the passenger cabin floor vertical acceleration (Figure 40), the vertical velocity at impact, as obtained from measurements of photographs, was 45 feet per second. This agrees satisfactorily with a computed value of 42.5 feet per second. The integrated acceleration-time curve gives the velocity curve shown at the bottom of the graph. A residual velocity error of about 6 feet per second or about 13 percent of the initial impact velocity of 45 feet per second is seen to exist. This is well within the over-all expected tolerance for dynamic measurements of the complexity encountered of this test. It represents an average error for the 0.18 second impact duration of 1G or 1 percent of the peak value recorded.

This same analysis has been used in the presentation of the records in Figures 41, 42, and 43, for the vertical acceleration of the cockpit floor, the passenger chest area, and the longitudinal acceleration of the cockpit floor. Referring to Figure 41, it will be seen that a velocity error of only 3 feet per second remains at 0.20 second. Thus, excellent agreement between the integrated acceleration-time curve and the expected value of zero residual velocity is evident.

For the passenger chest region, Figure 42, a residual velocity of 7.8 feet per second has been obtained by the integration of the "a-t" curve. In this case, however, this value cannot be considered as an "error" since:

- (a) The passenger dummy was partially free to move with respect to the airframe, and the chest area of the dummy thus need not necessarily have the same velocity of even a nearby point of the aircraft at corresponding times.

- (b) The passenger dummy did not remain oriented in a completely vertical position during the impact. * This would reduce an otherwise anticipated velocity decrease in the vertical direction from 45 feet per second to some lesser value. In fact, any longitudinal acceleration of the aircraft occurring as, or after, the torso of the dummy fell forward (as shown in Figure 36) would show up as a "negative" or downward acceleration on the vertical accelerometer located within the chest cavity. This would leave an "indicated" residual velocity such as observed in Figure 42.

In Figure 43, which shows the original and attenuated oscillograph records for the longitudinal motion of the cockpit floor, the velocity-time curve has been obtained as outlined in the foregoing procedure. In addition, the v-t curve has been integrated to give the longitudinal displacement of the floor for the first 0.20 second of the impact. Measured displacements, as obtained from high-speed photographs, are also shown at selected times along the curve. Excellent agreement of the displacements obtained by these two methods is evident.

The force-time curves obtained with tensiometers installed in seat belts and shoulder harnesses only can be partially checked. The method requires a comparison of the computed accelerations, based on the measured belt forces and restraint-subject masses, with the accelerations measured within the subject. Only an approximate order of magnitude can be so obtained because of certain unknown forces (from seat pan, rudder pedals, etc.) and the lack of rigidity of the mass of the dummy occupants.

4. Correlation with Photographic Evidence (See Figures 44-1 through 44-8)

Correlation of two or more acceleration or force-time histories, or particularly of photographs with the various time histories, are providing excellent means of analyzing and interpreting the results of this test. Referring to the sequence photo 44-2 and to the attenuated acceleration-time curve, it will be observed that at 0.025 second (tire blowing) the LH gear has not appreciably decelerated the passenger compartment floor. At 0.05 second, with both gears on

*As observed from the high-speed motion pictures covering this area.

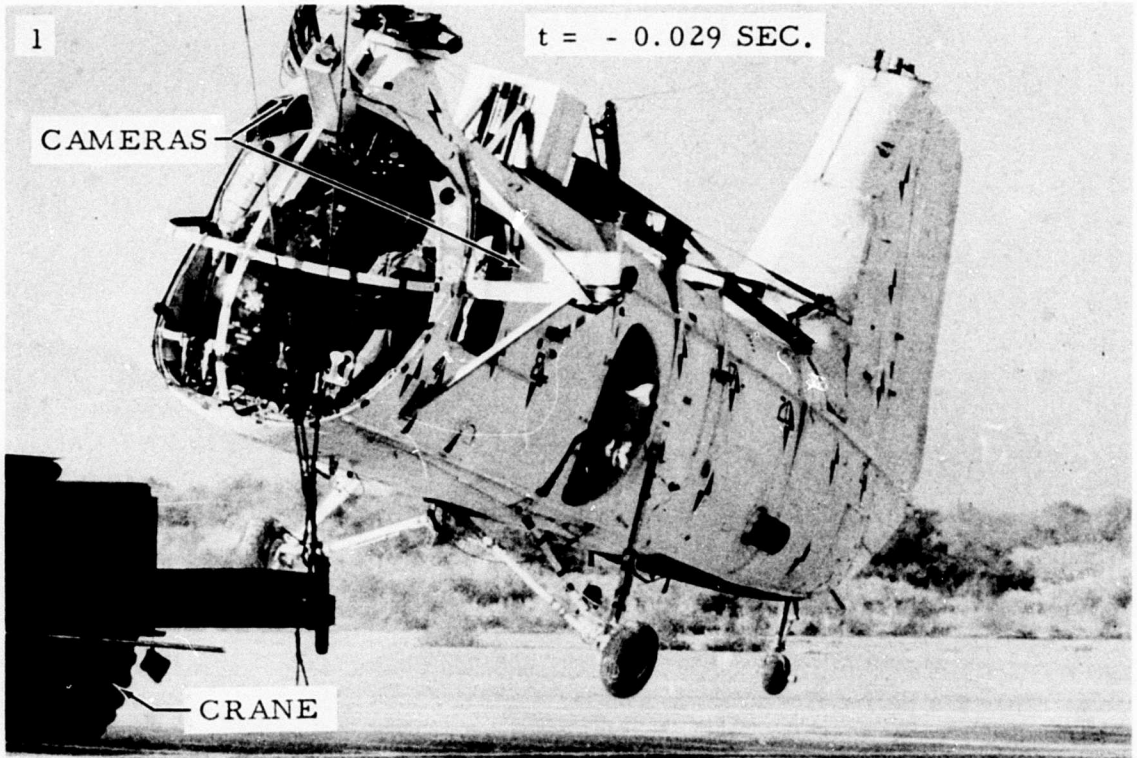

Figure 44-1 Sequence Photograph , H-25 Drop Test

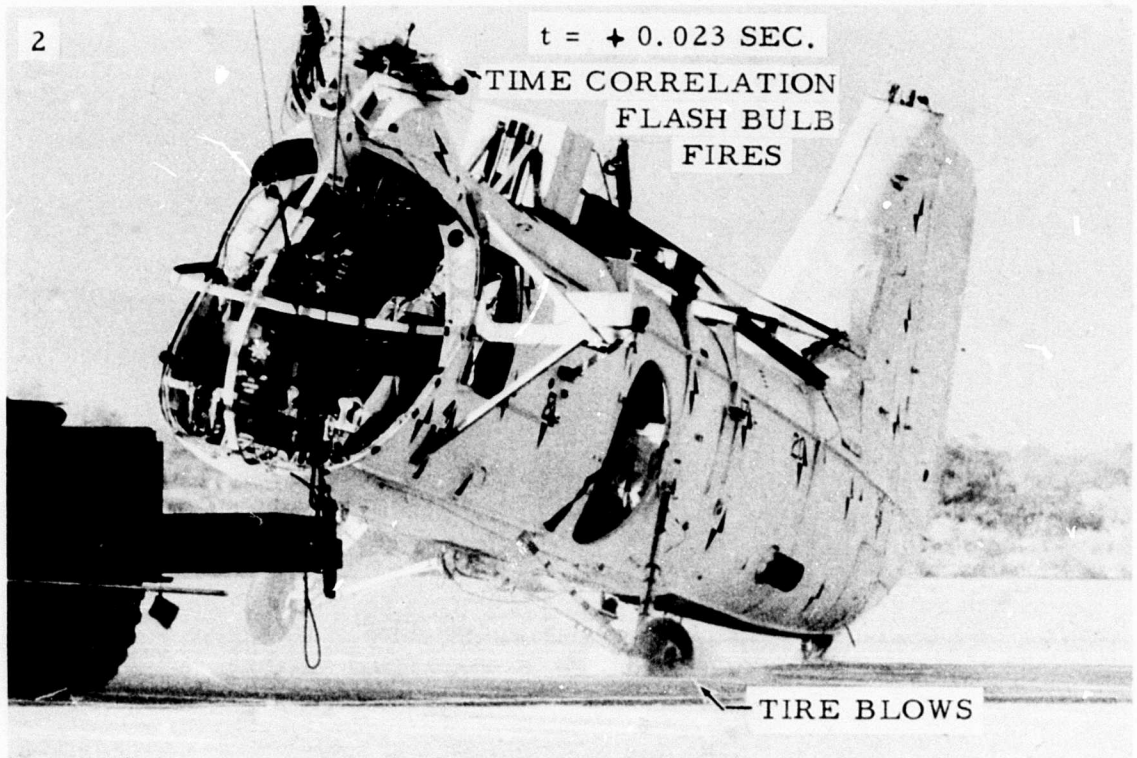

Figure 44-2 Sequence Photograph , H-25 Drop Test

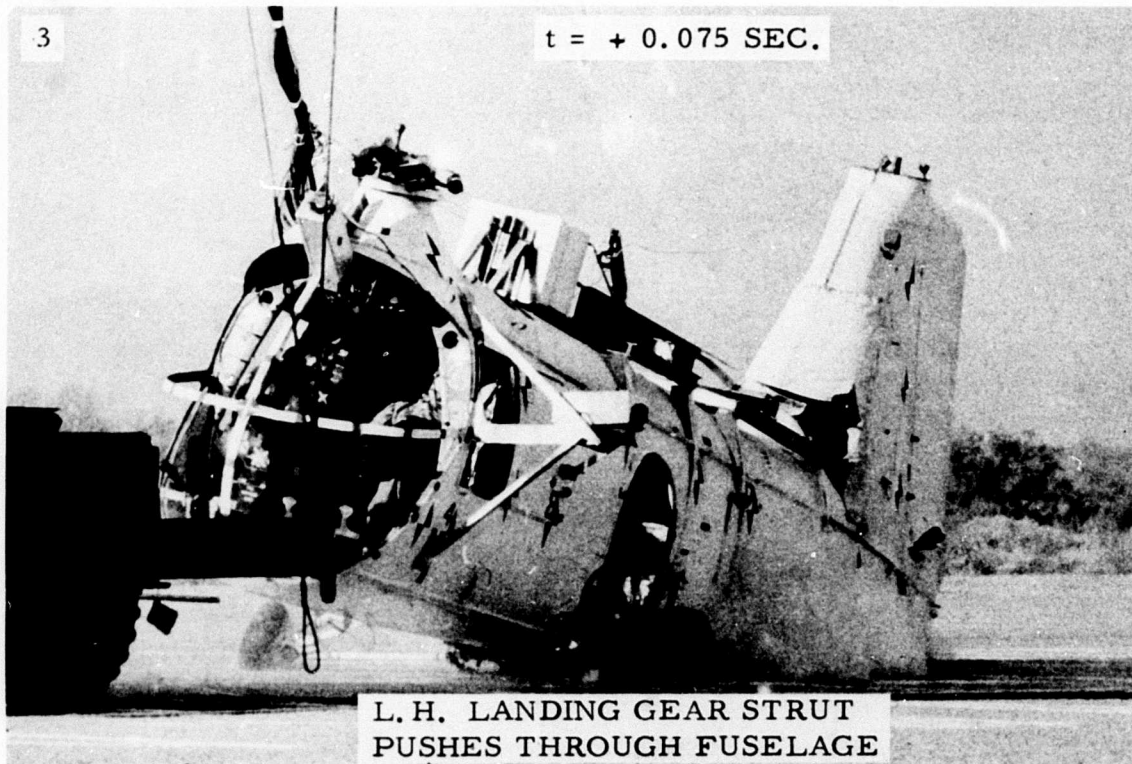

Figure 44-3 Sequence Photograph , H-25 Drop Test

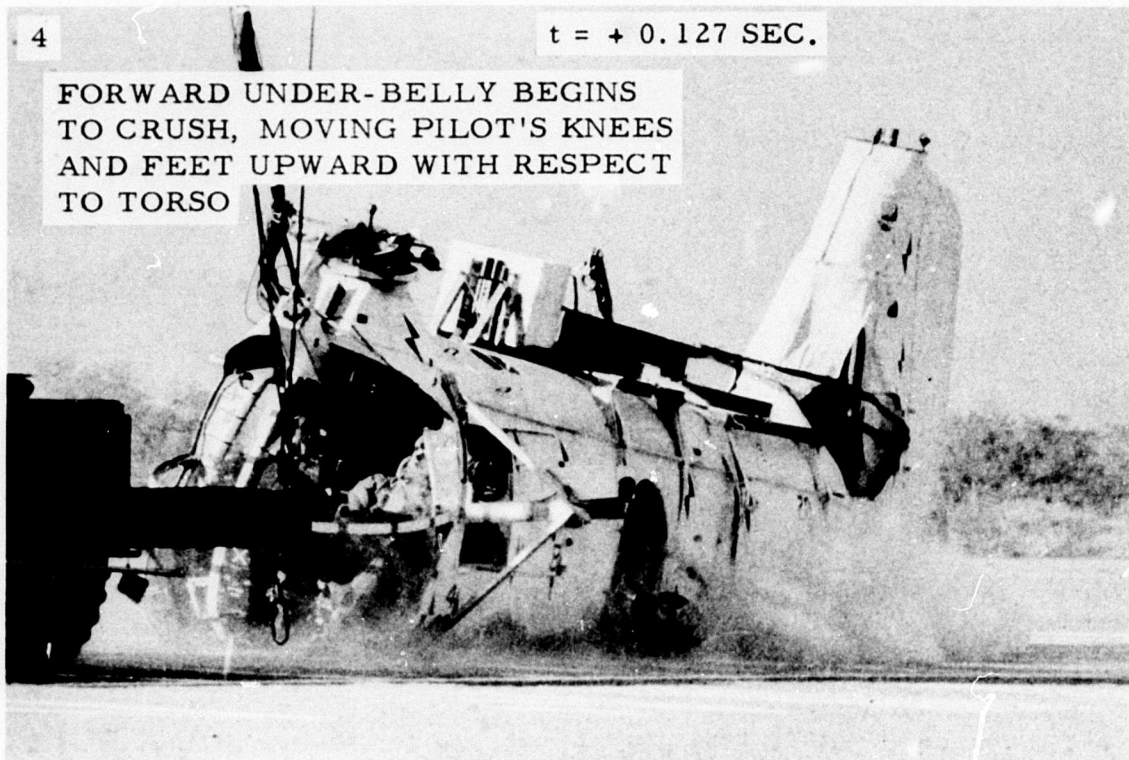

Figure 44-4 Sequence Photograph , H-25 Drop Test

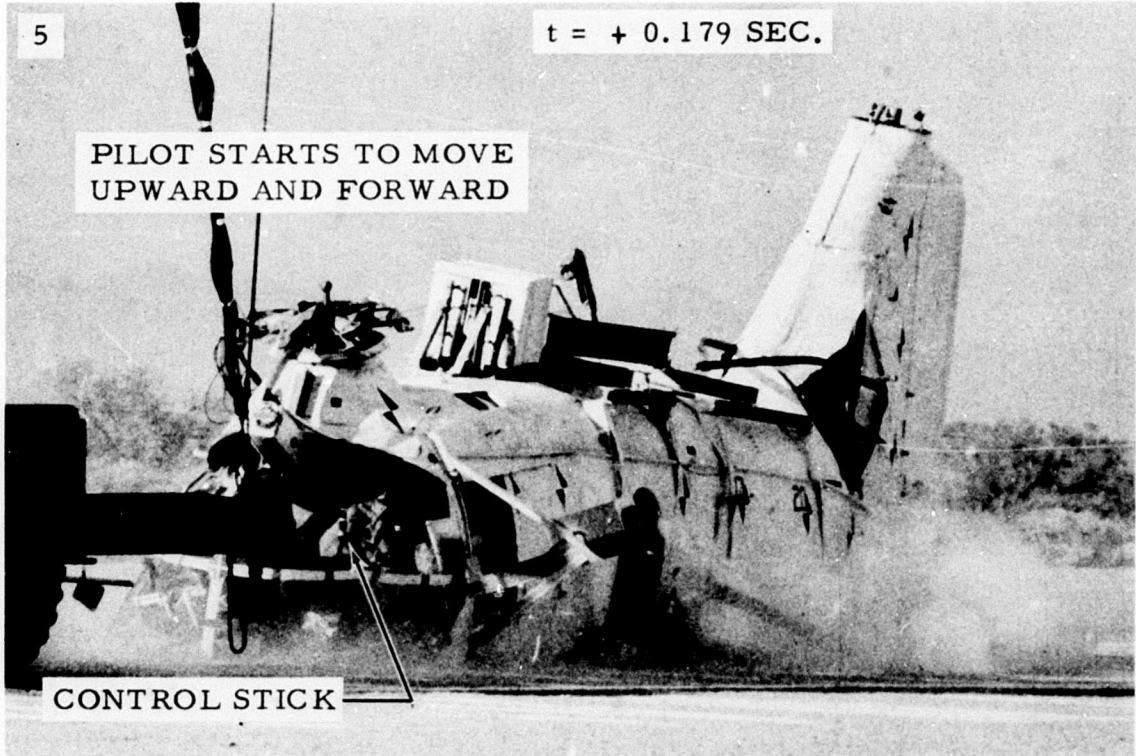

Figure 44-5 Sequence Photograph , H-25 Drop Test

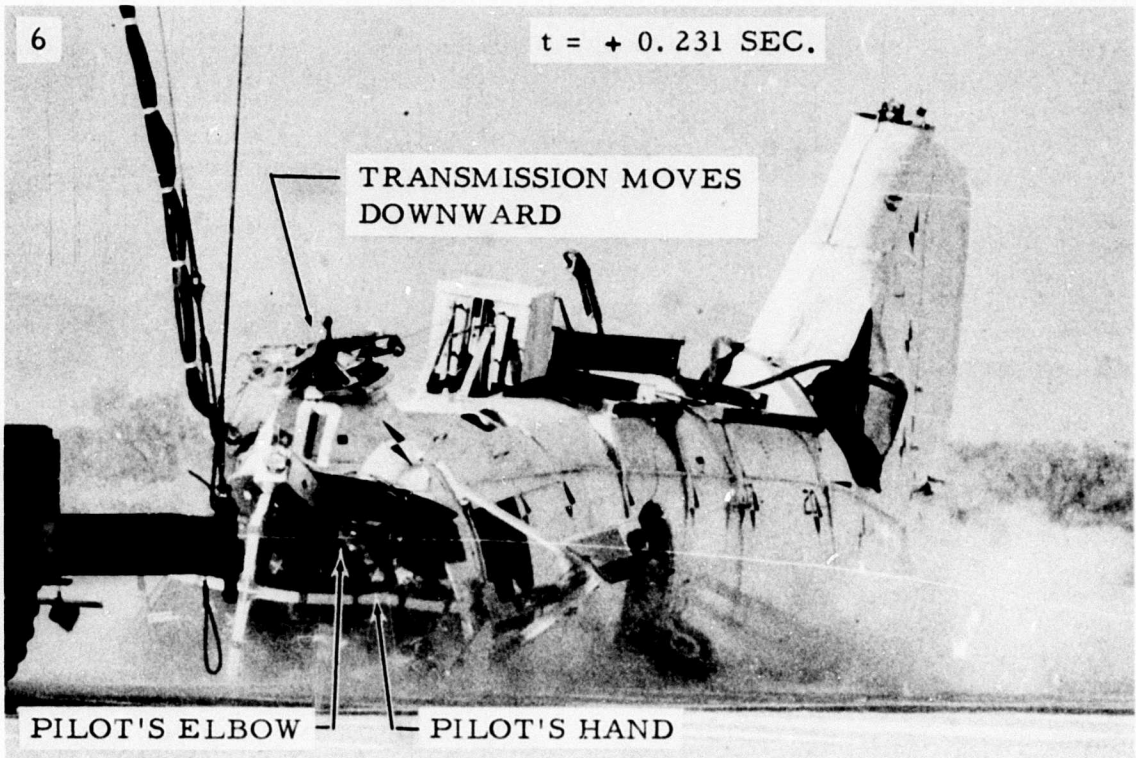

Figure 44-6 Sequence Photograph , H-25 Drop Test

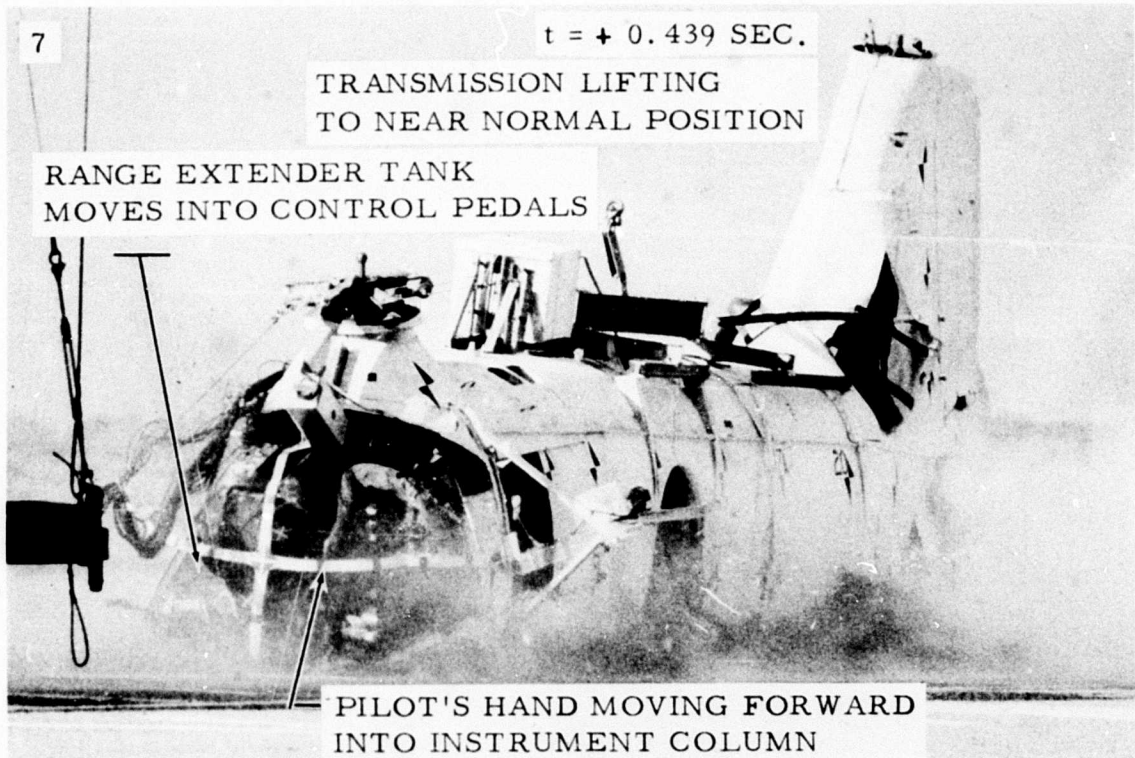

Figure 44-7 Sequence Photograph , H-25 Drop Test

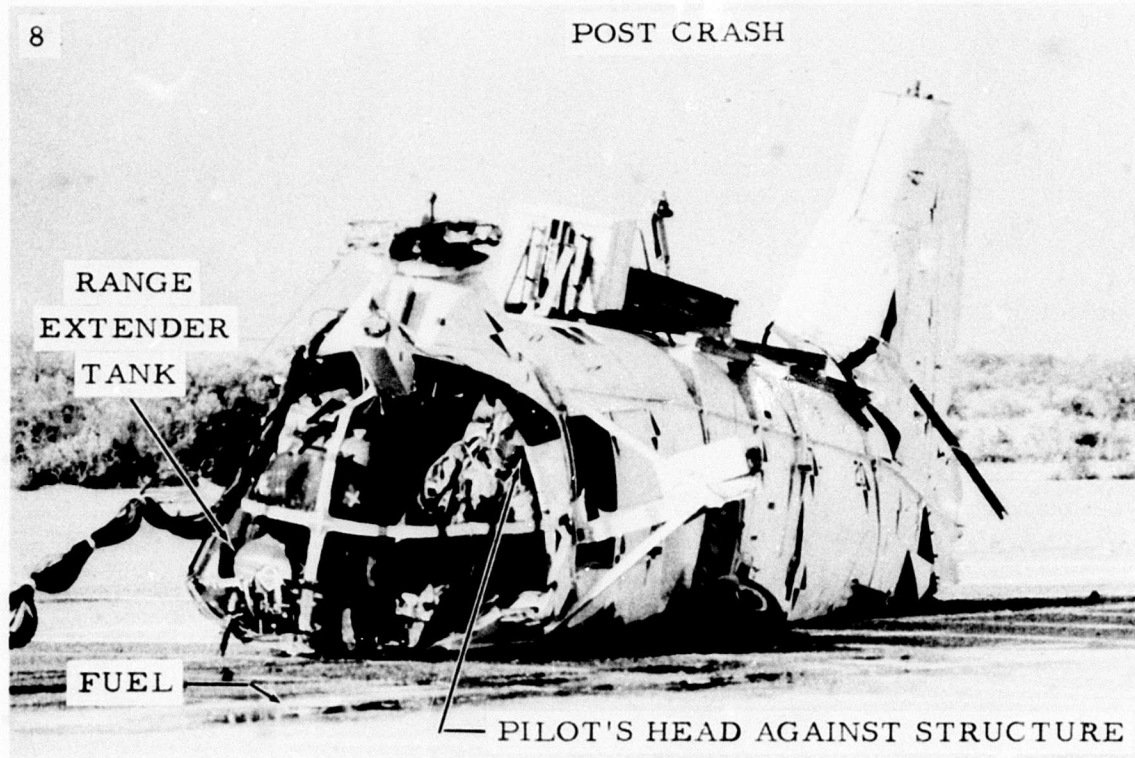

Figure 44-8 Sequence Photograph , H-25 Drop Test

the ground (photo not shown), an upward acceleration of 20G is recorded. This drops off at 0.06 second, both gears having failed at their attach points. At 0.075 second (photo 44-3) the compartment floor is contacting the ground and the acceleration begins to rise, peaking at 102G at 0.102 second. At 0.127 second the cabin floor has been arrested and from this time onward only random oscillations in the structure occur to move the acceleration-time curve from the zero position. Much later, at 0.179 and 0.231 second, the transmission begins to lower and the pilot is thrown upward and forward.

At 0.439 second (photo 44-7) the transmission is returning to a near normal position. The pilot and range extender tank are still moving forward with the front of the range extender tank approaching the control pedals. Much of this forward shift of the pilot and the tank were due to the buckling of the seat legs. Photograph 44-8 was taken approximately one minute after all motion of the aircraft had ceased.

Correlation of the oscillograph records with the high-speed 16 mm. movies has been previously mentioned in the discussion of the longitudinal displacement of the cockpit floor. As a further example of the utilization of these movies, the reader is referred to Figure 42. Observation of the 16 mm. film obtained from Camera No. 4A (see Figure 11) shows that the passenger dummy starts to move downward relative to the airframe at 0.105 second. A 13G upward acceleration pulse (Figure 42) occurring at this time, then decreasing, confirms failure of the seat structure. The movie clearly shows a sudden stoppage of the relative vertical motion of the dummy and airframe at 0.15 second indicating that the dummy is being arrested by the floor while sitting upright. A peak vertical acceleration of 56G was recorded in the chest cavity of the dummy at 0.155 second. An integration of the v-t curve in Figure 42 shows a vertical displacement of the dummy of 1.35 feet which corresponds closely to the height (1.25 feet) of the troop seat occupied by the dummy.

5. Oscillograph Records

All oscillograph records are being analyzed in the manner described in the preceding four sections and, upon final evaluation with photographic and other evidence, will be presented in appropriate technical publications.

BLANK PAGE

CONCLUSIONS AND RECOMMENDATIONS

This test, in a preliminary initial evaluation, must be considered successful from the standpoint of operation of the data gathering equipment, both in the air and on the ground. However, the ultimate value of the test will not be known until final interpretation and evaluation of the data and comparison of it with actual crash results is completed.

The design work done and the investigations made in preparing the test set-up in conducting the test and in interpreting the results has and will continue to add useful knowledge and experience which is applicable to the continuation of this program.

With specific reference to the objectives listed in paragraph 1 of Test Objectives, and restated here, the following conclusions have been reached:

OBJECTIVE 1 - "TO MEASURE CRASH FORCES ON PILOT AND/OR PASSENGER SEATS, SEAT TIE-DOWN STRUCTURE, FLOOR STRUCTURE AND OTHER COMPONENTS OF A ROTARY-WING AIRCRAFT AFFECTING OCCUPANT PROTECTION IN AIRCRAFT ACCIDENTS"

PLAN OF ACTION:

As stated earlier in this report, Objective 1 was accomplished by installing instrumentation pick-ups at a total of 34 locations in the aircraft. Each accelerometer, transducer, and strain-bar was located to give the most complete information possible on both the vehicle structure and its occupants for the limited number of recording channels available.

RESULTS:

The oscillograph records obtained were very good with close to 100 percent of the instrumentation apparently functioning.

RECOMMENDATIONS:

Because of the shape of the acceleration-time curves in a test such as this, care must be taken not to overcrowd the oscillograph record to the extent that removal of data is jeopardized. In this test, 20 out of 26 channels were used on the airborne oscillograph and 15 and 13 out of 18 channels were used on ground oscillograph Numbers 1 and 2, respectively. It is recommended that these numbers not be exceeded and, if possible, reduced.

Since the general characteristics of the measurements to be recorded are now known, in future tests a more precise placement of the oscillograph traces on the record could be made. The chance of introducing errors due to the overlapping of traces could thus be better avoided.

OBJECTIVE 2 - "TO DETERMINE THE FEASIBILITY OF AIRBORNE RECORDING AND THE RELIABILITY OF PHOTOGRAPHIC AND ELECTRONIC RECORDING EQUIPMENT"

PLAN OF ACTION:

The most immediate problem in the design of a practical airborne recording system was the development of an energy absorption system capable of shock-mounting the equipment so that it would not suffer permanent damage during the crash and, further, would record properly while undergoing deceleration.

A design, development, testing program was undertaken to obtain the optimum energy absorption system possible for the proposed test. After a successful design satisfying the space and weight limitations of the test article had been obtained, a test was conducted subjecting the actual electronic equipment to the anticipated shock conditions. The equipment was observed to operate satisfactorily during this test and good records were obtained.

A comprehensive presentation of the design, development, testing, installation, and functioning of the shock-mounting devices for the airborne oscillograph is given in Appendix B.

Since past experience had proven that high-speed cameras are capable of operating satisfactorily under 50G shock forces and since no movement of the cameras was desired during their operation, it was decided to install the cameras in protective containers and rigidly mount them to the helicopter fuselage structure.

RESULTS:

The quality of records obtained from the airborne oscillograph during the H-25A test suggests that an independent airborne instrumentation system is probably feasible, although it is doubtful at this time that completely satisfactory results were obtained in this test. The system used during this test was completely independent, including its own power supply. A ground calibrator was used for economy reasons. The inclusion of an airborne calibrator should be a rather simple matter, as no elaborate shock-mounting, such as was required for the

oscillograph inverter and timer during this test, would be required.

An excellent record (without reference to the validity of data) was obtained from the airborne oscillograph, including a post-drop calibration. Accelerometers installed within the airborne oscillograph package indicated that a peak vertical loading of 20G was sustained for a period of 0.008 second by the equipment without extensive detrimental effects to recording ability. A definite answer had not been determined at the time of this writing for the erratic action of the longitudinal trace and for the apparent 50G horizontal acceleration sustained at 0.18 second after impact.

The 60 cycle time pulse which was placed on both the ground and airborne oscillographs was displaced from the normal position on the airborne instrument in the interval from about 0.10 second to about 0.20 second. This is the interval in which maximum discrepancy between airborne and ground recorders has been found.

A study of the 8 duplicate traces obtained on the airborne and ground oscillographs has definitely shown that some discrepancies do exist. The source of these errors is being further investigated. In future tests some duplicate recording should be done on ground recorders. Hi-G recorders are under development and should be investigated as a better solution to the on-board recording problem.

Rigid mounting of the airborne cameras proved to be the correct approach since the cameras operated satisfactorily during the crash with very little crash oscillation being transmitted to the pictures. There were, however, two instances of failure of the camera frame attachment to the helicopter structure which caused movement after impact. The interior side camera, attached to fuselage frames, was ripped from its mounting due to severe damage to these frames from crushing of the fuselage by the right hand landing gear forward strut. The outside side-camera aft support-frame was torn from the left hand side of the fuselage at its connection causing the camera to slightly pivot about its forward connection. No loss in photographic coverage resulted, however.

RECOMMENDATIONS:

Although the shock-mounting of the airborne oscillograph recording system may be considered moderately successful with certain tentative reservations, the following undesirable features remain as problem areas since space available for installing this equipment may be limited in future tests:

1. Size of Container

The container was larger than desired due to the size and shape of the oscillograph and inverter. Since it was necessary to shock-mount each one in the same manner, the simplest way being to place the two in one container. This eliminated the necessity of having two separate energy absorption systems. Satisfactory operation of the equipment required that each unit be mounted in the container in an upright position. Since the shapes of the two units were quite different and required safety packing, the container size was quite large (20" x 40" x 16" depth). The space requirement for the CEC timer was negligible since it was placed in an otherwise unused area of the rectangular package.

Possible means of reducing the package size are to use a smaller size oscillograph and inverter, or to reduce the thickness of the safety packing around the equipment; the disadvantages of each solution are apparent.

2. Deceleration Distance of Container

The distance required in this test to completely absorb the energy of the electronic package for its vertical contact velocity of 42.5 feet per second without exceeding a 15G loading was 30 inches for a 75 percent efficient energy absorption system. Since the package and its installation required approximately 24 inches depth, it was necessary to have a space with a minimum of 54 inches vertical distance available.

This requirement, plus the necessity of having 18 inches minimum available for forward motion of the package and adequate clearances, indicate a space requirement that could be a problem since such space will not be available in a smaller test vehicle.

From the experience with the airborne cameras in the test, it is recommended for future tests of similar aircraft that the mounting of any equipment required to survive the effects of the crash without movement be made to the uppermost fuselage structure possible. It is also recommended that attachment of such equipment to structure near landing gear tie-ins be avoided.

The following recommendations are made for improving the quality of the film from cameras installed on and in the helicopter:

1. To fully utilize the qualities of color film, the items to be photographed should be painted more completely with bright and contrasting colors. The use of dark or drab colors is to be avoided.
2. Supplemental light must be used in the interior of the test article. The area to be photographed should be free of deep shadows if maximum detail is to be obtained. The lighting should be sufficient so that loss of any incidental light will not affect the quality of the film. Since proper lighting is basically a trial and error procedure, adequate time in the pre-crash installation period must be allowed for sufficient test shots and developing delays.
3. The film speed of at least some of the cameras could be reduced from 1,000 frames per second to 500 frames per second or less. This reduction in speed would help reduce the lighting problem and would not adversely affect the performance of the test.
4. The use of super wide angle lens should be avoided where possible because of the inherent distortion associated with them. A reduction in the area of coverage would sometimes be preferred to the super wide angle lens when data is to be taken from the film.
5. More consideration as to the time of the tests should be given since two of the four high-speed airborne cameras utilized natural light. The color intensity of natural light drops rapidly after mid-afternoon, so the tests should be completed prior to this time. The optimum time for a test would be between the hours of noon and 2 o'clock.
6. In general, additional research and consultations with other experienced people in this field would be advisable for future tests.
7. 35 mm. and 70 mm. equipment should be used where possible.

OBJECTIVE 3 - "TO MAKE GENERAL DETERMINATIONS OF PROBLEMS INHERENT IN EXPERIMENTAL TESTING FOR USE IN THE DESIGN OF SUBSEQUENT EXPERIMENTS OF A MORE COMPLEX NATURE."

PLAN OF ACTION:

The plan used during this program was to investigate analytically the problems arising during the test set-up stage and, where concern remained or further proof was necessary, to conduct auxiliary tests. This approach was used in (1) the determination of the drop system used to simulate a "typical" helicopter crash and (2) in the development of the energy absorption device for the airborne electronic equipment shock-mounting.

It also was planned to observe ways of improving the set-up during its installation and operation and to make note of pitfalls when they occurred so that future tests could benefit from the experience gained. The test set-up, systems, and components were to be observed during the crash test to permit appropriate modification for future tests.

RESULTS:

The results of drop tests conducted using a moving crane are given in the Test Results and Appendix A of this report. Other drop systems evaluated analytically are illustrated in Appendix A.

Except for the inability of the crane to reach the desired velocity of 35 miles per hour, the functioning of the test set-up was entirely satisfactory (actual speed was 30 mph). The automatic triggering device and release hook functioned properly with the vehicle impacting close to target dead center. The pay-out of the umbilical cable was perfect. The crane decelerated to a complete stop without disconnecting the umbilical cable, thus enabling the ground equipment to record the complete event and permitting the running of a post-drop calibration of the oscillograph systems.

The results of tests conducted on the airborne oscillograph shock-mounting are given in Appendix B of this report and, therefore, will not be repeated here.

The difficulties experienced with the electric release hook, a small item in the test set-up but a setback to the test schedule, when it did not function properly are reported in the results of the log drop-test and check drops on pages 45 and 46, respectively, of this report.

Another minor but aggravating problem was the draining of battery power during instrumentation check-out requiring the time consuming recharging of these vital components to the system. An adequate charging system should be an integral part of the test equipment.

RECOMMENDATIONS:

It is recommended that sufficient number of preliminary tests be conducted to prove the feasibility of each new method employed and the satisfactory operation of vital components. This procedure was followed in the H-25 test reported here and certainly contributed to its success.

The moving crane method was selected as the test method for this test because of its simplicity and low cost. It must certainly be recommended for any future H-25 tests and could be used for tests on smaller vehicles. It does, however, have limitations as to the size of the vehicle it can support and the maximum forward speed it can attain.

It is recommended that release hooks to be used be tested for operation under the maximum dynamic load anticipated.

Spare sets of batteries and a portable recharging system would be a wise investment to minimize delays in the program.

A more adequate power plant, including 3 phase 110-220v power supply, and a continuous-duty electrically powered air-compressor are recommended for field work.

APPENDIX A

VARIOUS METHODS OF SIMULATING CRASH CONDITIONS

VARIOUS METHODS OF SIMULATING CRASH CONDITION

The plan undertaken to duplicate the dynamics of the test condition, as specified in Par. 1 of Test Objectives was to investigate a number of test methods in order to determine the simplest, most reliable, low cost test set-up.

The following methods were considered:

1. Vertical drop of the helicopter onto an inclined plane;
2. Swinging the helicopter as a pendulum onto level ground;
3. Releasing the vehicle down an inclined monorail; and
4. Dropping the helicopter onto level ground using a moving crane.

The methods investigated are described in the following paragraphs listing the advantages and disadvantages of each:

1. Vertical Drop onto Inclined Plane

- a. Description

In this method, the specimen would be dropped onto a prepared surface inclined at an angle β with the horizontal.

The specified forward (horizontal) and vertical velocities determined the slope of the inclined plane.

$$a = \tan^{-1} \frac{29 \text{ miles per hour (vertical velocity)}}{35 \text{ miles per hour (horizontal velocity)}}$$

$$a = 40^\circ \quad \text{with vertical}$$

$$\beta = 50^\circ \quad \text{with horizontal}$$

The acceleration of gravity during free fall would impart the specified resultant velocity of 45 miles per hour (66 feet per second) to the helicopter.

APPENDIX A

The drop height was determined from the equation:

$$h = \frac{v^2}{2g}$$

$$h = \frac{66^2}{2(32.2)} = 67.7 \text{ ft.}$$

A crane would be required to lift the helicopter to the required drop height.

A sketch of the proposed method is presented as Figure A-1.

b. Advantages

- (1) Simple mechanics of method increases reliability.

c. Disadvantages

- (1) Cost of surface preparation at the required angle.
- (2) Arrestment of vehicle after crash.
- (3) Difficulties of working on such a grade during test set-up and test periods.
- (4) Undesirable angle for ground photographic coverage.
- (5) Inability to change condition.
- (6) Complicated hoisting arrangement for lifting vehicle at required angle.

2. Pendulum Method

a. Description

The specimen would be hoisted to the drop height (67.7 feet as in Method 1) necessary to produce the 45 miles per hour resultant velocity using a crane. A parallelogram type cable system, to provide stability, would be connected between the specimen and a tower. The pendulum pivot point would be located near the top of the tower at a point higher than the release point in order to improve release stability. At release the specimen would swing as a pendulum contacting level

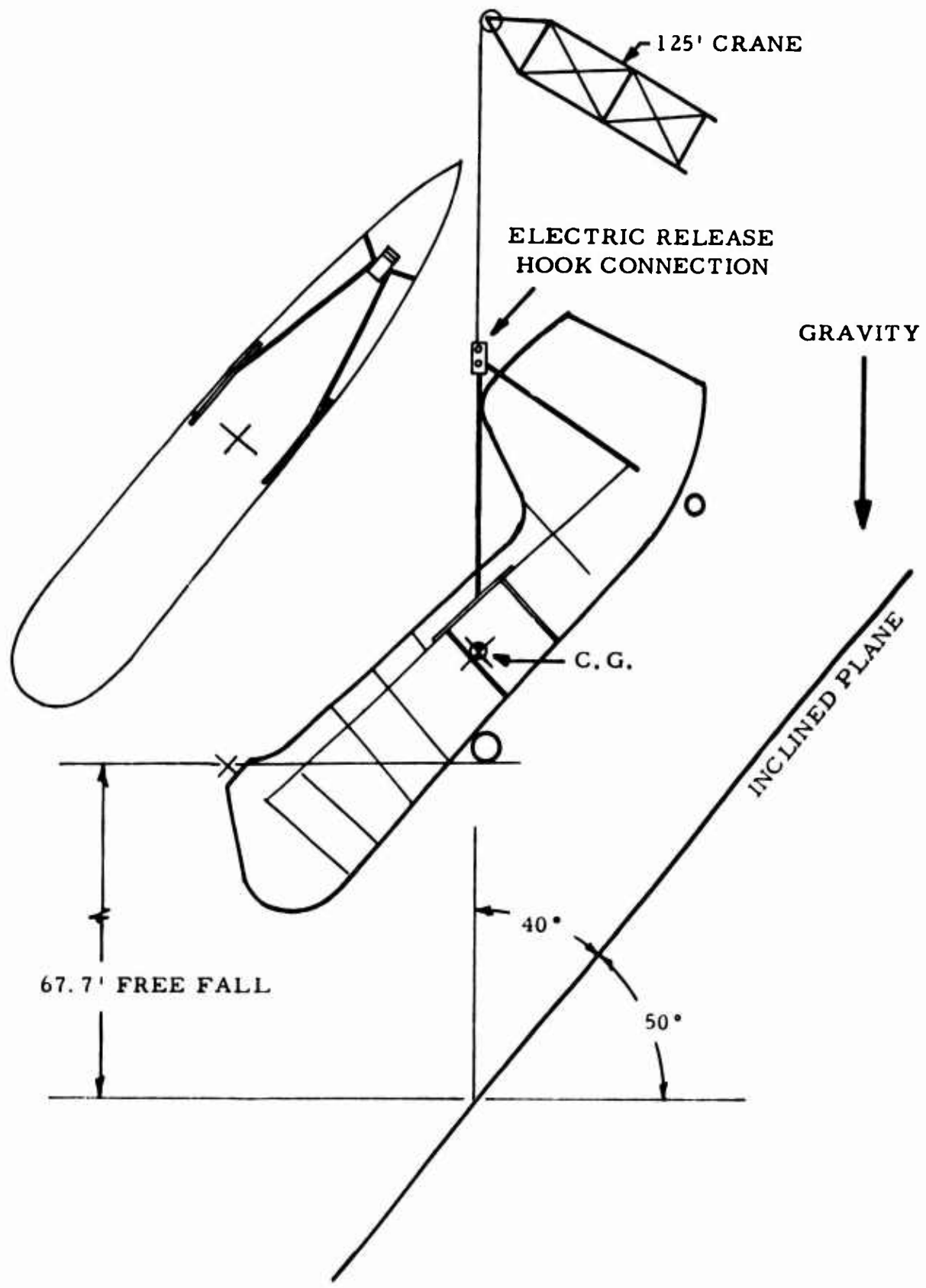

Figure A-1. Proposed Test Method of Dropping Specimen Onto 50° Inclined Plane

APPENDIX A

ground at the required 40° impact angle and with a 45 miles per hour resultant velocity. The geometry of the pivot point, release point, and ground would be such as to satisfy the specified crash condition.

A sketch of the proposed method is presented as Figure A-2.

b. Advantages

- (1) Flexibility of set-up in varying test condition by changing geometry of pivot and release points with ground.
- (2) The ability to impact onto a target on level ground under controlled conditions.

c. Disadvantages

- (1) Cost of set-up
- (2) Attachment of guide cables to specimen

3. Inclined Monorail Method

a. Description

The helicopter would be placed on an overhead inclined monorail at a location above the impact point necessary to produce the required vertical velocity by the acceleration of gravity.

The monorail would be inclined at an angle of 40° with the horizontal to satisfy the specified flight path velocity. At release, the specimen would move down the incline leaving the rail at the instant of impact. This would allow the helicopter to crash as a free body.

A winch located at the upper end of the monorail would be used to raise or lower the specimen to the release position.

A sketch of the proposed method is presented as Figure A-3.

b. Advantages

- (1) The ability to crash onto a target on level ground under controlled conditions.

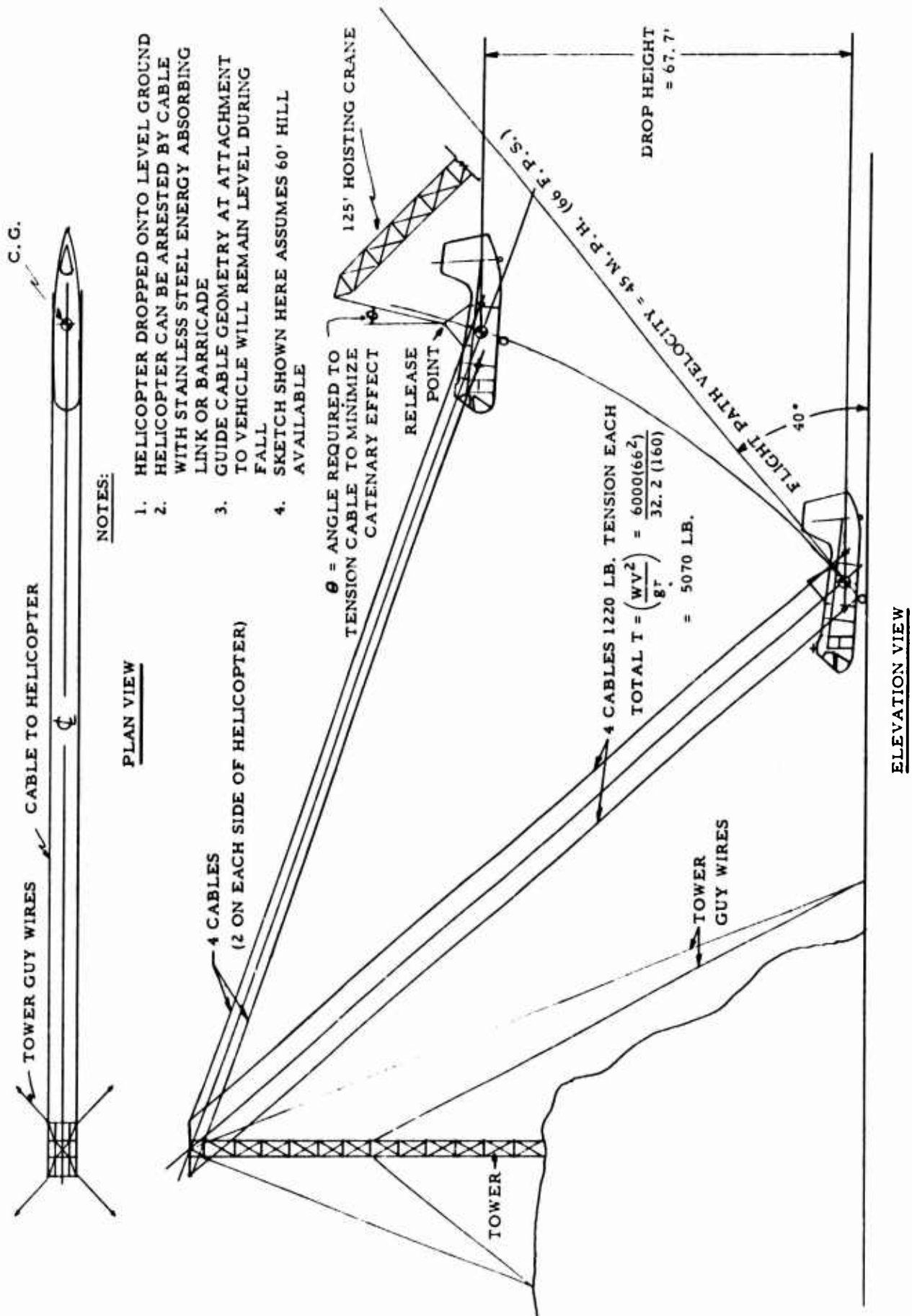

Figure A-2. Proposed Layout for Swinging Helicopter as a Pendulum.

NOTES:

1. HELICOPTER DROPPED ONTO LEVEL GROUND
2. HELICOPTER CAN BE ARRESTED WITH CABLE WITH STAINLESS STEEL ENERGY ABSORBING LINK OR BARRICADE
3. COMPLETE CONTROL OF HELICOPTER MOTION
4. PITCH, ROLL, OR YAW TENDENCY ELIMINATED USING 4 ROLLER ARRANGEMENT
5. EASY HELICOPTER PLACEMENT ONTO RAIL AND EASY OPERATION DURING TEST
6. NO 125' HOISTING CRANE REQUIRED
7. SKETCH SHOWN HERE ASSUMES HILL WITH APPROX. 40° SLOPE AVAILABLE

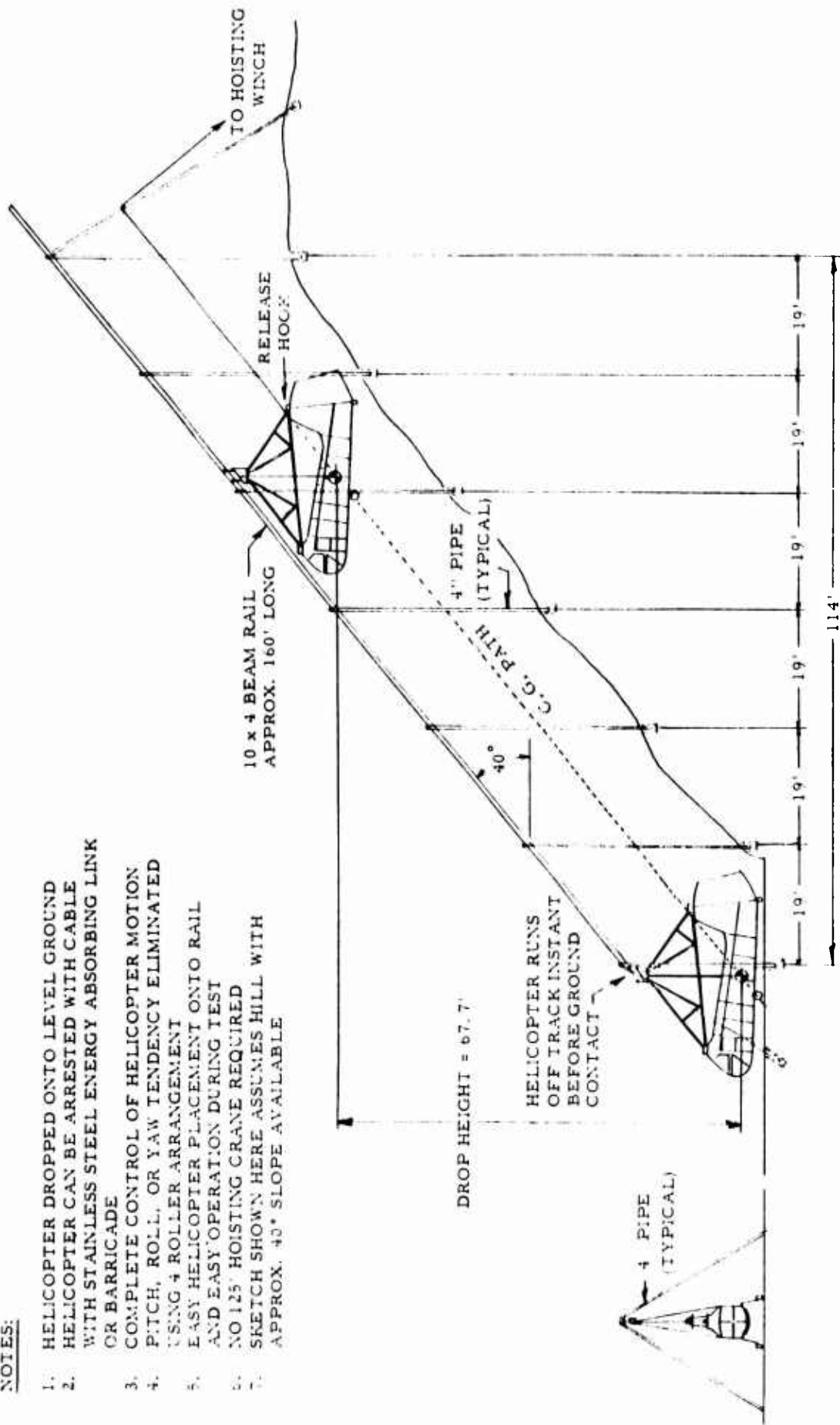

Figure A-3. Proposed Layout for Test Using Monorail System.

APPENDIX A

(2) No lift crane required.

c. Disadvantages

(1) Cost of set-up.

(2) Inability to change test conditions.

4. Moving Crane Method

a. Description

The helicopter would be suspended from the boom of a hoisting crane vehicle at a 28-foot distance above the ground in order to produce the specified 29 miles per hour vertical velocity by means of free fall. The crane vehicle would accelerate to the required 35 miles per hour forward velocity and release the helicopter allowing it to drop onto level ground at the specified flight path velocity.

A sketch of the proposed method is presented as Figure A-4.

b. Advantages

(1) Relatively low cost of system.

(2) Simplicity of set-up.

c. Disadvantages

(1) Requires ground instrumentation equipment to be mounted on a moving vehicle.

(2) Smooth crane running surface required.

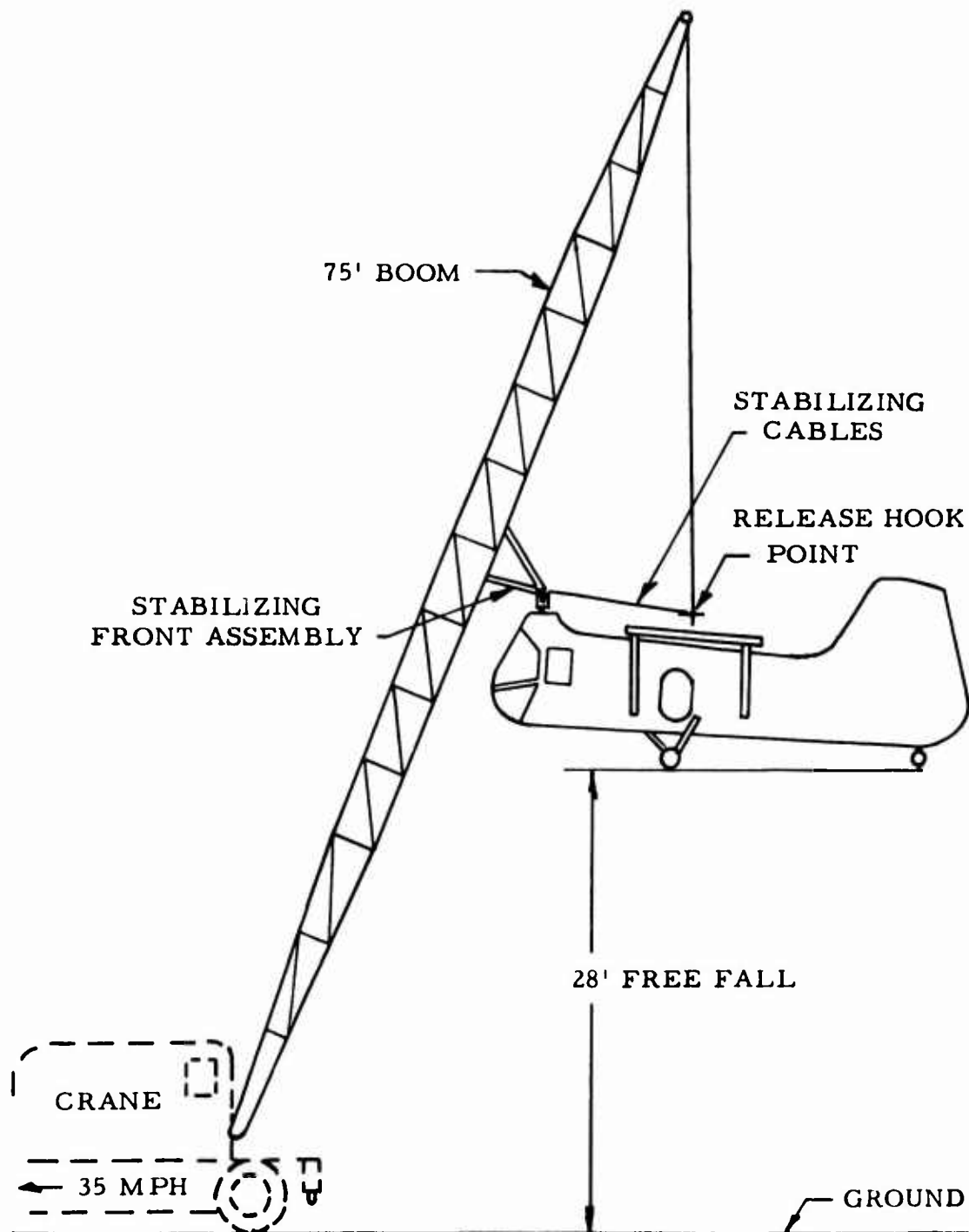

Figure A-4. Proposed Test Method Using Moving Crane to Drop Helicopter on Target While Moving at 35 M. P. H.

APPENDIX B

DESIGN AND DEVELOPMENT TESTING

OF

ENERGY ABSORPTION SYSTEM

FOR

THE SHOCK-MOUNTING OF AIRBORNE ELECTRONIC EQUIPMENT

BLANK PAGE

DESIGN, TESTING, INSTALLATION, AND OPERATION OF SHOCK
DEVICE FOR AIRBORNE ELECTRONIC EQUIPMENT

The second objective of the H-25A helicopter crash test program was to determine the feasibility of an independent airborne oscillographic recording system. The manufacturer of the equipment used in this test would not guarantee its proper operation at accelerations exceeding 15G's. It was necessary to shock-mount this equipment since accelerations anticipated during this test ranged from approximately 100G's on the cockpit and cabin floors to 40G's on the upper fuselage structure.

The equipment requiring this shock-mounting consisted of the following:

	<u>Weight</u>
1 - CEC 5-122 Oscillograph	85 lbs.
1 - CEC 5-053 Timer	4 lbs.
1 - Leland SE-2 Inverter	43 lbs.
Total Weight	132 lbs.

A container was designed to house the equipment. It contained styro-foam packing up to 4 inches thick to protect the equipment from a shock-loading in excess of 25G's in event of a shock absorption device failure.

The container was vented to prevent excessive heating of the enclosed electronic equipment during pre-drop check-out of the system. The container size was 20" wide x 40" long x 16" deep.

Design of Energy Absorption System

General Design

Due to the size of the electronic package container, it was necessary to locate the vertical shock device outside and on the top of the helicopter. Since the structure in this area was not designed for large vertical loads, it was necessary to keep the weight of the system at a minimum.

Dow styrofoam was selected as the energy absorption material because of its light weight (2 lbs. per ft.³) and high efficiency (75-80 percent dynamic).

APPENDIX B

The system would absorb energy by the squeezing of a block of styrofoam between two plates. A 5:1 pulley ratio was used to increase the squeezing load so that the styrofoam block would be shaped approximately as a cube. This increased the stability of the system. The electronic package was attached to the system by means of a cable.

Schematic Design

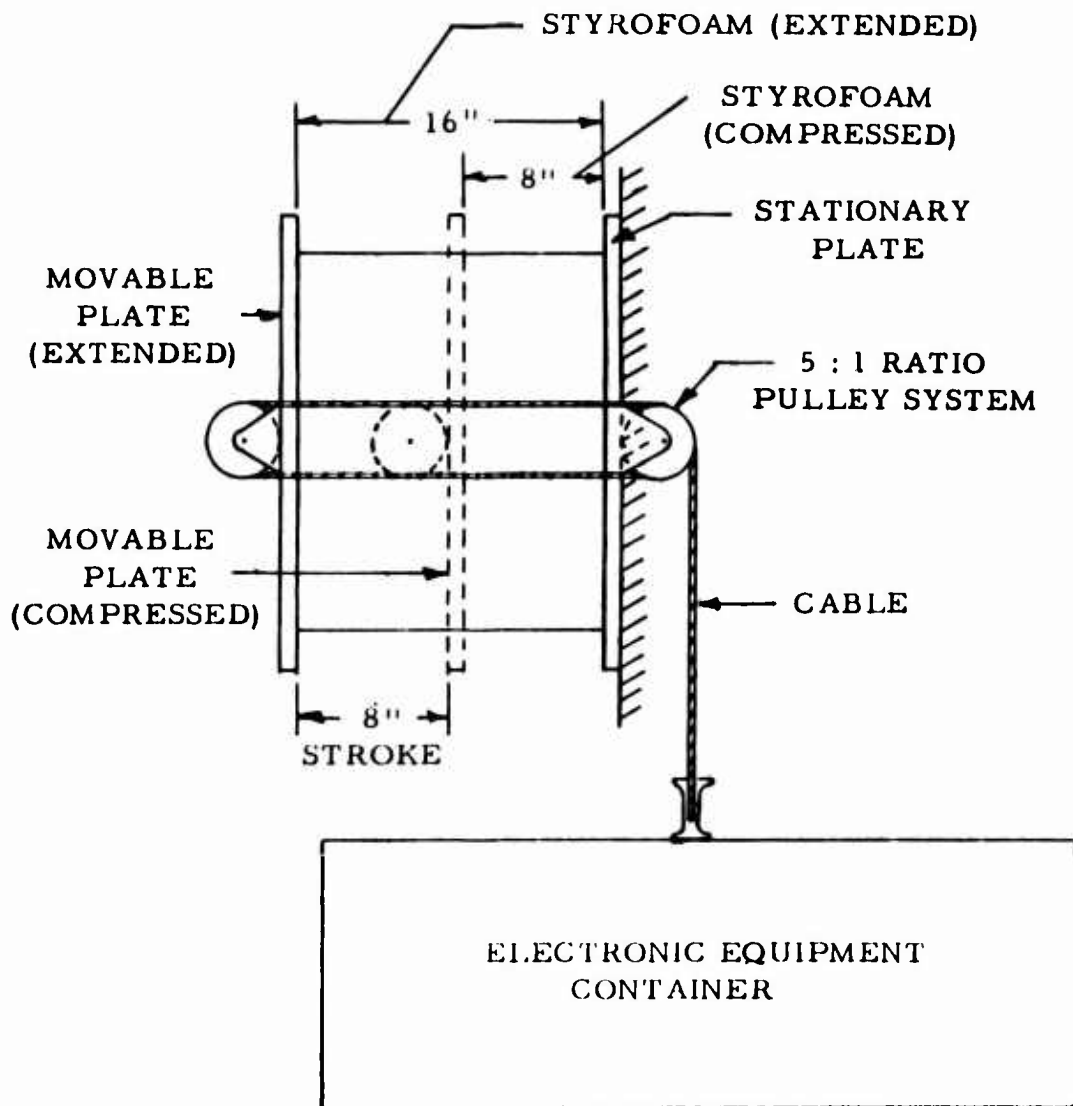

A photograph showing the energy absorption device and electronic package installation in a test rig is presented as Figure B-1. A photograph of the shock device after having absorbed its design energy is presented as Figure 29.

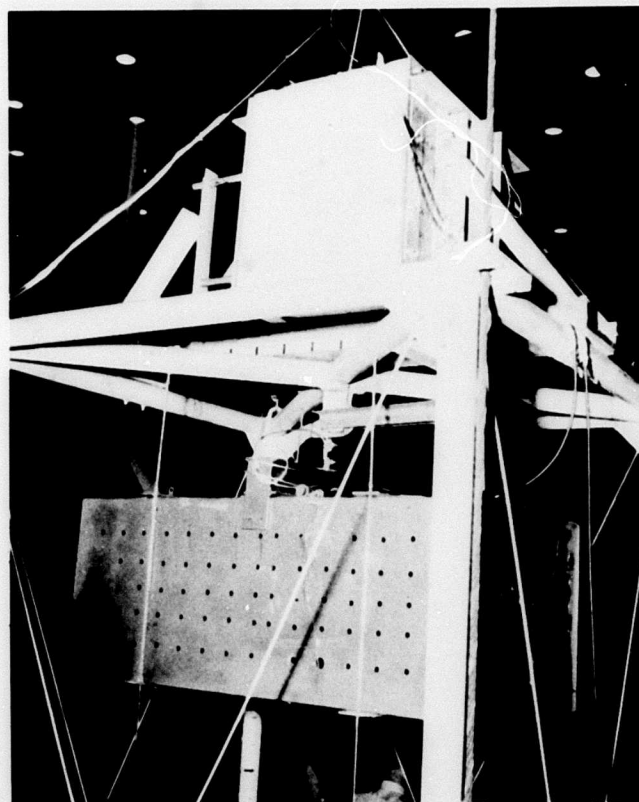

Figure B-1. Oscillograph Shock-Mount Test Set-Up Showing Energy Absorption Device and Electronic Package Before Drop

Design Criteria

Mass to be shock-mounted:

Electronic Equipment	132 lbs.
Container	121 lbs.
Total	<u>253 lbs.</u>

Velocity of Mass (Electronic Package)

Vertical Velocity	= 42.5 ft. per sec. (29 mph)
Forward (Horizontal) Velocity	= 51.3 ft. per sec. (35 mph)
Resultant Velocity	= 66.0 ft. per sec. (45 mph)

APPENDIX B

Vertical Energy

$$E = \frac{1}{2} MV^2$$

$$E = \frac{1}{2} \left(\frac{253}{322} \right) (42.5)^2 = 7,090 \text{ ft. - lbs. (85,000 in. - lbs.)}$$

Energy Absorption Material

Dow Styrofoam (2 lbs. per ft.³)

Dynamic Loading at 50% deflection = 32.5 psi

Vertical "G" Loading Desired = 10 "G's"

Load on Electronic Package Support = 10 x 253 = 2,530 lbs.

Load on Styrofoam using 5:1 Pulley Ratio = 5 x 2,530 = 12,650 lbs.

Area Styrofoam required at 50% deflection (Dynamic)

$$\frac{12,650}{32.5} = 390 \text{ sq. in.}$$

Area 19" x 22" used = 420 sq. in.

$$\text{System Stroke Requirement} = \frac{85,000}{12,650 (.75)} = 8.3''$$

75% Efficiency Styrofoam (dynamic)

Styrofoam Block Size = 19" x 22" x 16"

Vertical Movement Package = 8 x 5 = 40"

Efficiency of System (Dynamic) = approximately 75%

Test Program

In order to develop the most optimum energy absorption system and to verify the operation of the actual electronic equipment package, a test program was conducted.

A bird-cage type test-structure was constructed. The shock device and electronic package was installed into this fixture (see photograph, Figure B-2). The bird cage was dropped from a height of 25 feet to subject the package to the

40-feet-per-second terminal velocity anticipated during the helicopter crash. The bird cage was dropped onto styrofoam blocks to subject it to the 40G loading anticipated on the helicopter structure to which the shock device would be mounted. Photographs showing the test set-up prior to dropping, ready for drop, and after dropping, are presented as Figures B-2 through B-4.

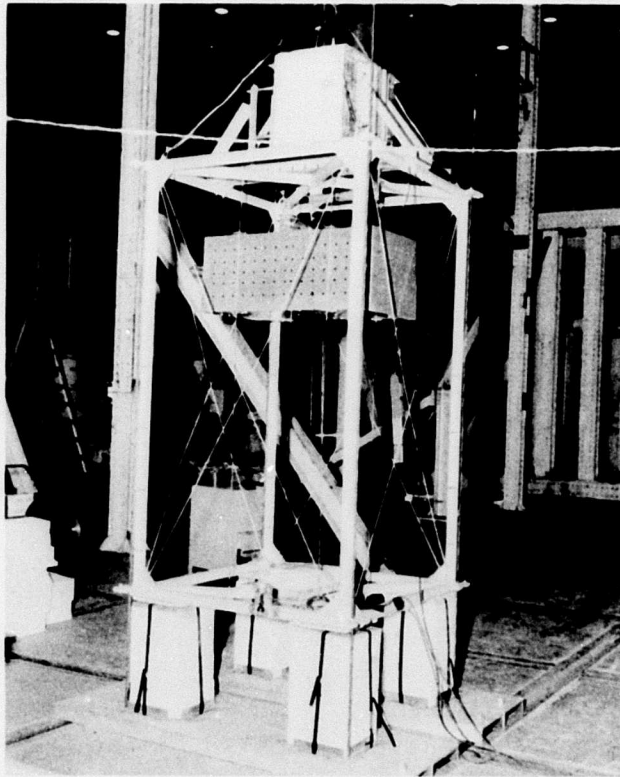

Figure B-2. Oscillograph Shock-Mount Test Pre-Drop Test Set-Up

During these tests, the design of the shock device was optimized with the following design established:

Styrofoam size: 19" deep x 22" wide x 16" long

Stroke: 7" at 44% styrofoam deflection

Vertical Movement of Package at 5:1 Ratio Stroke to travel: 34"

Maximum G Loading on Package: 11.5G's

APPENDIX B

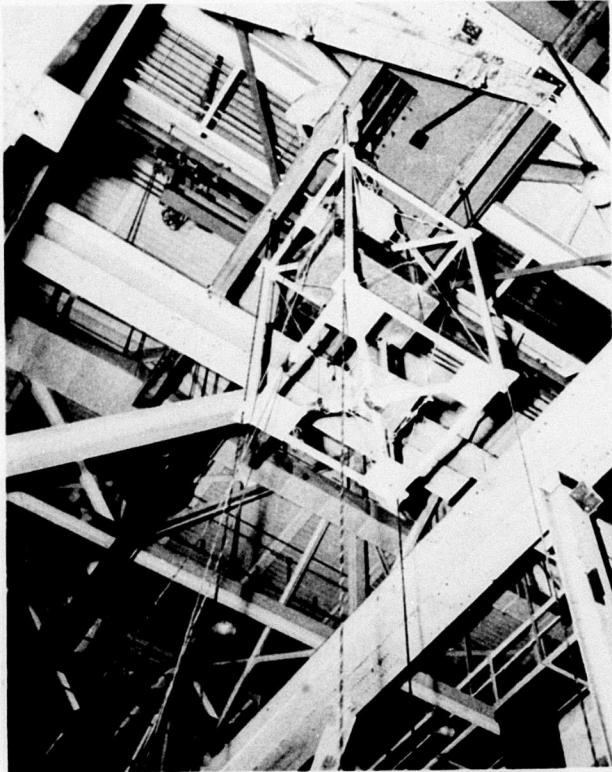
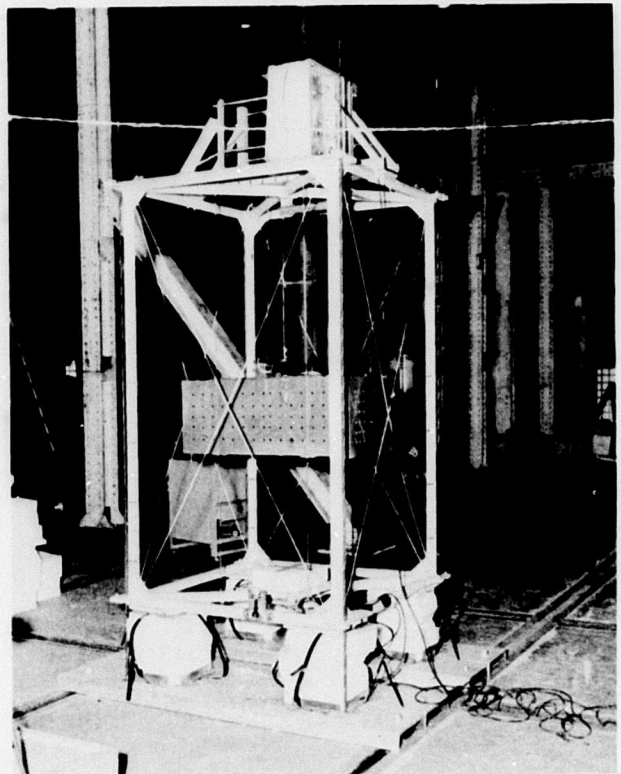

Figure B-3. Oscillograph Shock-Mount Test Ready for a Drop

Figure B-4. Oscillograph Shock-Mount Test Post-Drop View



APPENDIX B

The tests conducted to establish this design used dummy weights to simulate the electronic equipment. With the design accomplished actual electronic equipment was installed to observe its operation under the anticipated shock conditions of the crash. The equipment operated properly during the test with a good oscillograph record obtained.

Installation of Shock Device and Package in the Helicopter

The shock devices were installed in the helicopter. The vertical device imparting 12G's to the electronic package was installed outside and on top of the helicopter (see photograph, Figure 5). The longitudinal device imparting 8G's to the electronic package was installed on the passenger cabin rear shelf above the fuel cell (see photograph, Figure 15). Four vertical guide cables were connected to the helicopter fuselage structure to guide the package and prevent side sway. The fuselage frame at Station 136.8 was reinforced with a simple truss in order to support the vertical shock-device cable load.

Operation of Shock Device System During Crash Test

The shock system functioned properly during the actual crash test protecting the electronic equipment from the crash environment. The airborne oscillograph operated during the entire impact period producing a record of excellent quality; however, discrepancies have been found to exist between the records obtained by the airborne and ground recorders.

A more detailed description of the function of the recording equipment shock mounted during the crash test is given under the section on "Test Results" in the body of this report.

CALIBRATION TECHNIQUESCalibration Procedure

1. Accelerometers

The Statham type A5A and A6A accelerometers were calibrated on a Henry Whirling Arm Accelerator throughout their respective ranges.

2. Pressure Pickup

The Consolidated Electrodynamics Corporation Type 4-313 pressure pickup was calibrated on an Aschroft Gauge Tester Type 1312 through its respective range.

3. The force links used to measure harness and seat belt forces were calibrated on the test machine which loaded the link in specific steps throughout the range of the expected loads.

In order to adequately introduce the various symbols and terms which are used in the calibration and data reduction procedure, the following derivations are presented as a preliminary to the discussion of the procedure.

From the ordinary Wheatstone Bridge equation, the following equation relating the change of voltage output of a strain gage bridge to changes of resistance of the four arms is readily derived. (See figure below for explanation of symbols.)

$$E_g = E_b \cdot \frac{(\Delta_1 + \Delta_3) - (\Delta_2 + \Delta_4)}{4 \left(1 + \frac{R}{R_g} \right)} \cdot Z$$

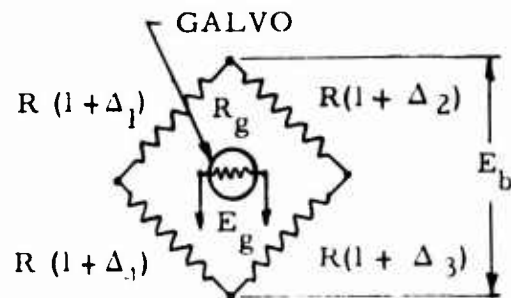

Where Z is a non-dimensional factor which is a measure of the non-linearity of the bridge and which may be considered equal to 1.00 for nearly all practical strain gage applications.

APPENDIX C

For ordinary strain gage bridges, it is convenient to assume:

$$\Delta_1 = \Delta_3 = GE \text{ and } \Delta_2 = \Delta_4 = -\mu GE$$

Where G relates the resistance changes in the gage to changes of strain and is usually denoted by: $G = \frac{\Delta R/R}{\text{strain in test member}}$ and $\mu =$ Poissons ratio.

Now if the number of active arms (N) be defined as $N = 2(1 + \mu)$, then the equation relating voltage changes to strain becomes:

$$E_g = E_b \frac{NGE}{4 \left(1 + \frac{R}{R_g}\right)} \quad (1)$$

For purposes of calibrating the recording equipment prior to and immediately after the drop, it is convenient to apply known voltages of the same order of magnitude as those obtained from straining the gages of the bridge. This is done by shunting one arm with precision resistors. This procedure is quite valuable in wire strain gaging techniques and is commonly termed a "Resistance Calibration." However, it is important to note that a resistance calibration only calibrates the characteristics of the recording equipment and not those of the strain gage installation. The change of resistance in one arm with a parallel resistance R_s shunted across it is readily found from the parallel resistance law as:

$$\frac{\Delta R}{R} = \frac{R}{R_s} \left(\frac{1}{1 + \frac{R}{R_s}} \right) \quad (2)$$

The voltage output produced by such a resistance change is then:

$$E_{g_o} - E_{g_i} = \frac{E_b}{4 \left(1 + \frac{R}{R_g}\right)} \times \frac{R}{R_s} \left(\frac{1}{1 + \frac{R}{R_s}} \right) \quad (3)$$

It is often convenient to know what value of strain gives the same voltage output as a certain value of shunt resistance R_s ; this is readily determined by comparing equations (2) and (3) which gives:

$$E = \frac{R}{NGR_s} \left(\frac{1}{1 + \frac{R}{R_s}} \right) \quad (4)$$

APPENDIX C

Hence, it is seen that this equation can be used to give a convenient method of calibrating the recorded indications in terms of applied strains. In order to facilitate making these "Resistance Calibrations", various types of strain gage resistance calibration equipment have been developed. Multi-channel, multiple step automatic calibrators are commonly employed for applications where large numbers of strain gage bridges must be calibrated. The automatic feature decreases the likelihood of operator errors when performing the resistance calibration and the multiple step calibration, which consists of several equal steps on either side of zero, is valuable as an indication of recording system linearity.

The strain (E) specified in equation (4) represents the equivalent change of strain per resistance step. This change of strain is usually denoted in our data reduction as K_r and will be used in the forthcoming discussions in this report. A table of values for K_r is presented as Table II. It is, also, desired to mention that the term enclosed by the brackets in equation (3) can be neglected in all normal computations. The remaining portion of this equation which will be utilized is as follows:

$$K_r = \frac{R}{NGR_s} = \frac{\text{STRAIN}}{\text{STEP}}$$

The value of the resistance calibration steps serves as an indication of the sensitivity of the recording system and for most practical applications the values of these steps can be averaged to obtain a mean step value. This mean step value will be denoted in all succeeding discussions by the symbol "b" (inches/step). Initial calibration of a strain gage installation, therefore, can be accomplished by the following method:

$$\frac{K_r}{b} (\delta - \delta_0) = E$$

Let δ_0 = deflection at zero load (inches)

δ = deflection at some unit load (inches)

$(\delta - \delta_0)$ = assumes the sign obtained by subtracting as indicated

K_r $\frac{(\text{strain})}{\text{step}}$ is established as shown in preceding paragraphs

b $\frac{(\text{inches})}{\text{step}}$ be the mean value obtained by resistance calibration

APPENDIX C

Table II. Values of K_r for CVA Resistance Box

2.6 ACTIVE ARMS

Bridge Resistance	R_s	120	180	240	300	350
Box 1	2×10^6	.1154	.1731	.2308	.2884	.3365
2	1×10^6	.2308	.3462	.4615	.5769	.6730
3	0.5×10^6	.4615	.6923	.9231	1.1539	1.3462
4	0.25×10^6	.9231	1.3846	1.8462	2.3077	2.6923
5	0.10×10^6	2.3077	3.4615	4.6154	5.7693	6.7308
6	0.05×10^6	4.6154	6.9231	9.2308	11.5385	13.4616
7	0.025×10^6	9.2307	13.8462	18.4616	23.0769	26.9231

4 ACTIVE ARMS

Bridge Resistance	R_s	120	180	240	300	350
Box 1	2×10^6	.075	.1125	.15	.1875	.2188
2	1×10^6	.150	.2250	.30	.3750	.4375
3	0.5×10^6	.30	.450	.60	.750	.875
4	0.25×10^6	.60	.900	1.20	1.50	1.750
5	0.10×10^6	1.50	2.25	3.00	3.75	4.375
6	0.05×10^6	3.00	4.50	6.00	7.50	8.750
7	0.025×10^6	6.00	9.00	12.00	15.00	17.50

Formula $K_r = \frac{R}{R_s} \times \frac{1}{N_g}$
 Note: Multiply all values by 10^{-4}

APPENDIX C

The sign of "b" is the sign obtained from $(\delta - \delta_0)$ when the shunt resistance is across the AC leg of the bridge.

Where E is the strain at the unit load corresponding to the trace deflection $(\delta - \delta_0)$ by applying successive unit loading conditions, a calibration curve or strain versus unit load can be obtained. For most installations this calibration curve will be in the form of a straight line and its slope may be conveniently determined by the method of least squares.