

18 (1)

CRASH INJURY EVALUATION

AD 664151

U. S. ARMY

AO-1BF MOHAWK MOCKUP

Bethpage, Long, Island, New York

31 March 1960

Reproduced by the
CLEARINGHOUSE
for Federal Scientific & Technical
Information Springfield Va. 22151

DDC
RECEIVED
DEC 28 1967
RECEIVED
L.C.



AVIATION CRASH INJURY RESEARCH

A DIVISION OF
FLIGHT SAFETY FOUNDATION, Inc.

2713 EAST AIRLINE WAY • SKY HARBOR AIRPORT • PHOENIX, ARIZONA

TREC Technical Report 60-45

COPY NO. 249

This document has been approved
for public release and sale;
its distribution is unlimited.

41

AO-1BF U. S. ARMY "MOHAWK" MOCKUP EVALUATION
Bethpage, Long Island, New York
31 March 1960

REPORT OF CRASH INJURY EVALUATION
AvCIR-12-PV-117
August 1960

FOR

United States Army
Transportation Research Command
Contract DA-44-177-TC-624

AVIATION CRASH INJURY RESEARCH
A Division of
Flight Safety Foundation, Inc.
2713 East Airline Way
Sky Harbor Airport
Phoenix, Arizona

Reproduction of the paper, in whole or in part,
is permitted for any purpose of the United States Government.

TREC Technical Report 60-45

GRUMMAN AO-1BF U. S. ARMY "MOHAWK"

MOCKUP

C R A S H I N J U R Y

E V A L U A T I O N

Harold F. Roegner

ACKNOWLEDGEMENT

The author expresses his gratitude to the Grumman Aircraft Engineering Corporation, Bethpage, Long Island, New York, for furnishing the photographs and drawings utilized in this report.

INDEX OF ILLUSTRATIONS

- Figure 1 Front quarter view of the Mohawk
- Figure 2 Three dimensional view
- Figure 3 Side view with SLAR and external fuel tanks
- Figure 4 A reduced scale drawing of the forward portion of the Mohawk
- Figure 5 Outboard view of the Lycoming T53-L-3 engine
- Figure 6 View of the exterior rescue and danger area markings
- Figure 7 Overall cockpit view
- Figure 8 View of the Martin-Baker seat
- Figure 9 Front view showing cockpit side entrances
- Figure 10 Close-up of the pilot's instrument panel
- Figure 11 Close-up of the instrument panel and the center pedestal
- Figure 12 Close-up view of the engine control pedestal
- Figure 13 Radio console panel located between the occupants' seats
- Figure 14 View of overhead console which is located between the two occupants
- Figure 15 The left eyebrow panel is depicted
- Figure 16 The arrow denotes the emergency hatch release.
- Figure 17 The sharp injury producing edges on the side panels are denoted by the arrows

FOREWORD

In its efforts to determine the crash survival aspects of aircraft accidents, AvCIR, a division of the Flight Safety Foundation, is guided by certain criteria which it considers fundamental for the crash protection of aircraft occupants. The same criteria are also used to evaluate the crash safety features of mock-ups and prototypes.

Following is a brief description of these criteria:

1. Crashworthiness: The ability of basic aircraft structure to provide protection to occupants during survivable impact conditions.
2. Tie-down chain: All the components of the occupant seating and restraint system including the seat belt, the shoulder harness, the seat structure, the floor and all related anchorages.
3. Occupant environment: The injury potential of all objects and structure within the occupant's striking range.
4. Transmission of crash force: The manner in which crash forces are transmitted (magnified or attenuated) by intervening structure to the occupants.
5. Post-crash factors: Post-crash fire, inadequate emergency exits, poor ditching characteristics, etc..

For a more elaborate discussion of crash safety criteria, reference is made to Appendix I.

BACKGROUND

A crash injury evaluation of Grumman AO-1BF U. S. Army "Mohawk" was conducted by AvCIR, a division of the Flight Safety Foundation, at the request of the U. S. Army TRECOM.

Data were compiled at a meeting of a mock-up review board, which was held at the Grumman factory, Bethpage, L. I., New York, on 31 March 1960.

The purpose of the evaluation was to:

1. Evaluate the overall crashworthiness of the basic aircraft structure.
2. Determine the existence, if any, of certain features which could lead to the unnecessary exposure of crew members to serious or fatal injury in the event of a survivable-type accident.
3. Make recommendations for remedial action in order to decrease the exposure of the crew members to certain injury causation factors (see Appendix I).
4. If necessary, recommend additional crash safety design be integrated into the basic overall design of the aircraft.

The above work was accomplished through a detailed crash injury evaluation of the entire aircraft, its components and equipment, in combination with references to technical manuals and personal contact with members of the Grumman engineering staff. Photographs* were taken to document and emphasize those features which are considered injury-causation factors in the AO-1BF design.

This is the final report on the crash injury evaluation.

* Additional copies of the photographs used in this report may be obtained by forwarding request to USA, TRECOM, Fort Eustis, Virginia, Attn: RCO.

SUMMARY

On 31 March 1960 a crash injury evaluation of the Grumman AO-1BF U. S. Army Mohawk was conducted by a representative of Aviation Crash Injury Research, a division of the Flight Safety Foundation, for the U. S. Army Transportation Research Command under contract number DA-44-177-TC-624.

The evaluation revealed that the Mohawk incorporates many desirable features which generally help prevent injuries in the event of an accident:

1. The cockpit is stressed for 40 G.
2. The Martin-Baker ejection seats currently being utilized incorporate two desirable features: a 40 G seat and a continually locked shoulder harness.
3. The self-sealing fuel tank is located in the fuselage above the center section with two bulkheads separating the fuel tank area from the cockpit.
4. Further protection is afforded by the 1-inch thick windshield and the utilization of 1/2 inch armor plate for the cockpit floor.
5. The relatively slow landing speed is another of the desirable features incorporated into the Mohawk.

The evaluation also revealed that certain design hazards that may contribute to injuries in the event of an accident were noted:

1. The pilot's instrument panel, the eyebrow panels and the overhead console contain a large assortment of knobs, switches and protruding instruments which could produce head injuries. A large number of sharp edges and corners are also present around the instruments. The possibility of getting all of the instruments, knobs and switches recessed or the instrument panel adequately padded is quite remote. Therefore, in order for the occupants to obtain maximum protection at all times, it must be stressed emphatically that the restraint system, safety belt and shoulder harness, plus the helmet, be utilized at all times in the prescribed manner.
2. The operation of the side entrances, the amount of clearance when the side panels are in an open position and the inability to jettison these side panels under emergency conditions could delay the evacuation of the occupants in the event they were injured.

As a result of the above findings, the following recommendations are made:

1. Orders be issued making it mandatory that crew members utilize the restraint system and hard hats at all times while flying the Mohawk.
2. Consideration be given to making the side panels jettisonable from both the interior and the exterior.



Figure 1. Front quarter view of the Mohawk.

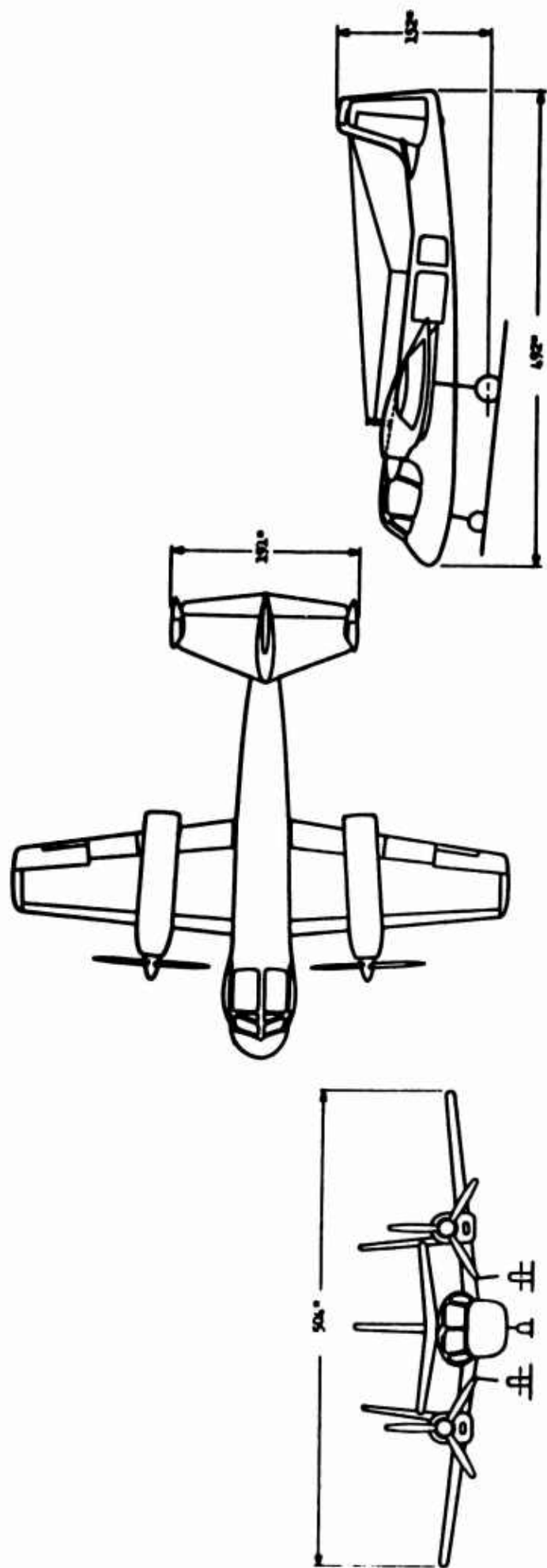

Figure 2. Three-dimensional view.

DESCRIPTION OF AIRCRAFT

GENERAL

The Grumman AO-1BF Mohawk is a two-place, twin turbo-prop, all-weather aircraft having STOL capability and designed to operate from small, unimproved fields, for purposes of tactical observation and surveillance.

The twin-turbo-prop aircraft has an extremely small turning radius and, with wing slots and flaps extended, is able to "hold" over a ground position by flying a tight figure-eight pattern.

The short landing capability of the Mohawk (55 knots) is enhanced by reversible pitch propellers fitted to the Lycoming T53-L-3 turbine engines. By applying full reverse pitch power upon landing, the aircraft can be brought to a stop in approximately 300 feet.

The aircraft has a 5.3 aspect ratio wing, large flap area and wing slots. The hydraulically actuated slots work in conjunction with the flaps. The flaps have three positions: up, 25 degrees down for take-off, and 45 degrees for landing. The propeller diameters cover about 50 percent of the total wing span.

Increased lateral stability with the flaps down was provided by making the flaps outboard of the engines serve as auxiliary ailerons. These flaps, called inboard ailerons, do not extend more than 25 degrees. The inboard ailerons move through 50 degrees of arc from 25 degrees down at neutral aileron to 25 degrees up at full-up aileron. These inboard ailerons are the only hydraulically boosted control surfaces on the aircraft. Other flight controls, including trim tabs, are manually operated.

In addition to flaps and wing slots, the AO-1BF is fitted with hydraulically actuated speed brakes which extend from the sides of the fuselage. The speed brakes will permit the aircraft to dive from its economical cruise altitude of 25,000 feet to tree top level.

The straight and level top speed of the Mohawk is approximately 275 knots and the designed service ceiling is 32,000 feet. Structurally, the aircraft can withstand positive 5 G up to its design limit speed of 390 knots. Rolling pullups are limited to 4 G.

Production AO-1BF's will carry either side-looking radar (SLAR) or infrared mapping equipment. The avionic compartments of the plane are accessible through latched doors on the fuselage within easy reach of a man standing on the ground. The main fuel cell can be readily replaced by removing two panels on the upper fuselage. In addition to providing ease of access, all major assemblies are interchangeable. Powerplant packages will fit left or right wings. Major landing gear components, stabilizer, elevator and outboard fins and rudders are interchangeable left and right. The complete wing panel including engine nacelle is replaceable, and wing tips, horizontal and vertical tails, fuselage nose and tail sections are replaceable as units.

Photographs of the interior utilized in this report are of the AO-1AF, which is essentially identical to the AO-1BF except for a larger avionic equipment complement.



Figure 3. Side view with SLAR and external fuel tanks.

G-44748

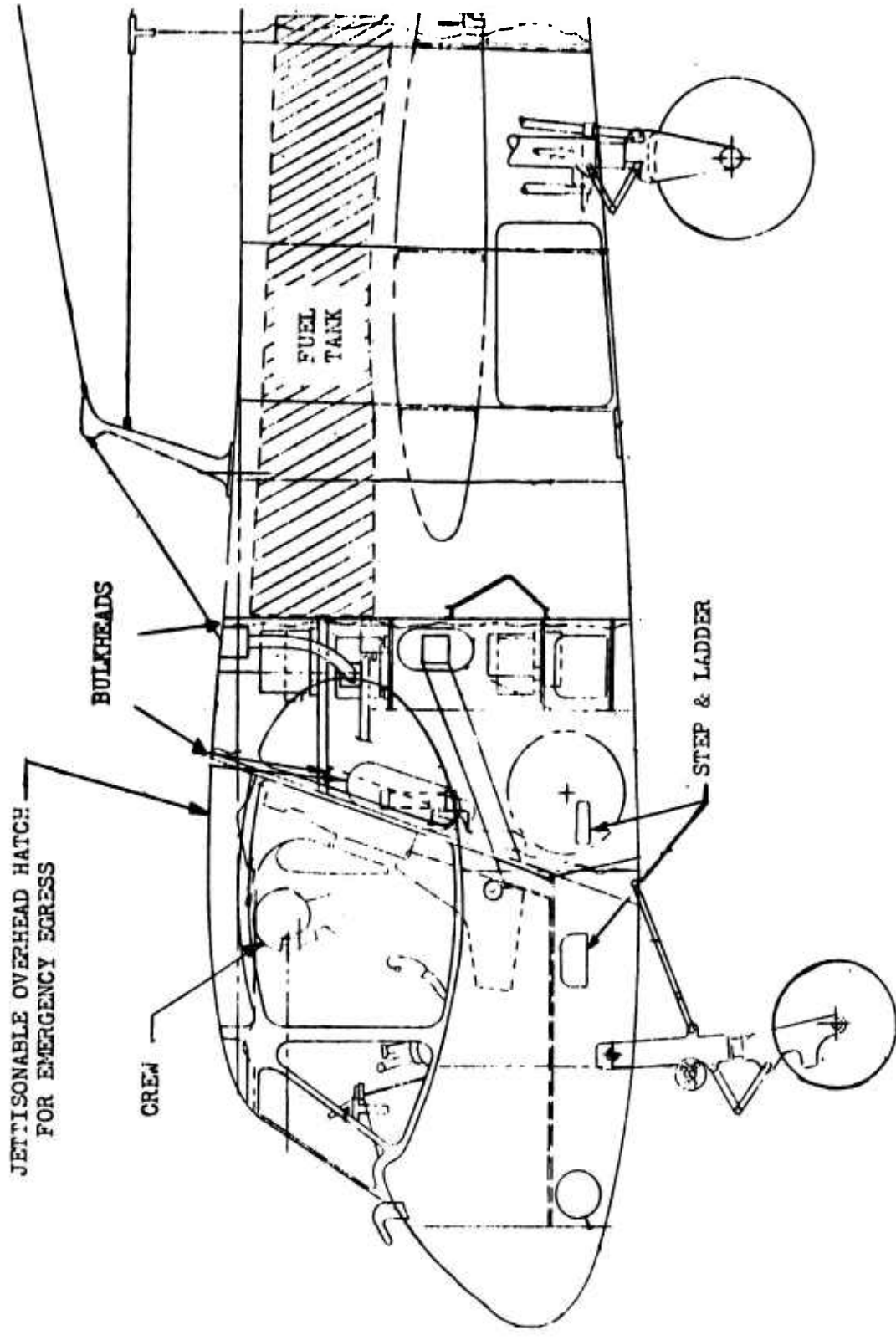

Figure 4. A reduced scale drawing of the forward portion of the Mohawk. Note the normal seated position of the pilot.

EVALUATION OF BASIC AIRFRAME

GENERAL DISCUSSION

During analysis of the Mohawk, it was found that a considerable number of desirable crashworthy items were incorporated into the aircraft. These features are:

1. The cockpit is stressed for 40 G.
2. The self-sealing fuel tank, Figure 4, is located in the fuselage above the center section with two bulkheads separating the fuel tank area from the cockpit.
3. Further protection is afforded by the one-inch thick windshield and utilization of 1/2 -inch armor plate for the cockpit floor.
4. The relatively slow landing speed (55 knots) is also a desirable feature.
5. The Mohawk utilizes an in-flight fire extinguishing system in the engine nacelles, which is manually controlled by the pilot. Substantial post-crash fire protection could be provided with the incorporation of an impact actuated switch in this system. (See Post-Crash Factors in Appendix I.)

Figure 5 depicts an outboard view of the Lycoming T53-L-3 engine utilized on the Mohawk, which develops 1,005 ESHP at take-off. At the present time, it appears that the engines are adequately mounted; however, lack of time prevented detailed analysis which might predict the manner in which the engines would tear loose in the event of an accident.

The exterior markings (Figure 1 and 6) in regard to the exit release, ejection seat, and the propeller danger area are well placed and legible from a considerable distance. The rescue arrow, upper left in this photo and also in Figure 1, pointing out the exit release, is deemed adequate for rescue personnel.

In addition to the markings mentioned above, one additional marking should be added to the aircraft which specifies the location of the hand fire extinguisher. Fire and crash trucks are not always readily available; therefore, the time spent trying to locate the fire extinguisher might prove costly in the event of a post-crash fire.

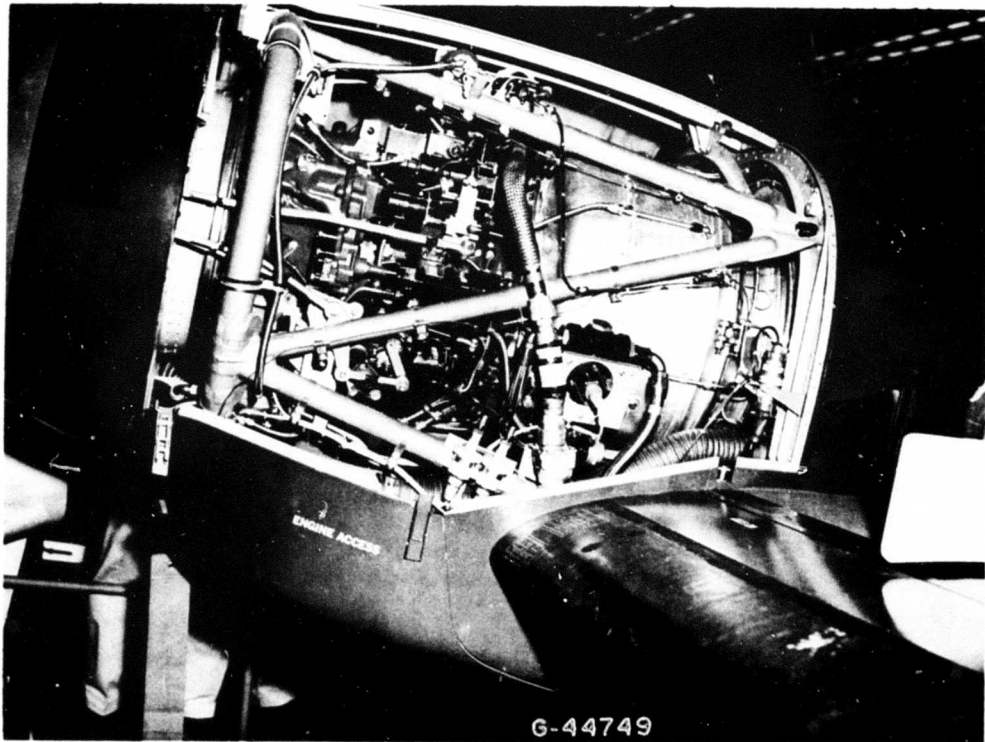

Figure 5. Outboard view of the Lycoming T53-L-3 engine.



Figure 6. View of the exterior rescue and danger area markings.

CONCLUSIONS

After examination of the basic airframe of the Mohawk, it is concluded that:

1. The crashworthy characteristics of the basic airframe are excellent.
2. Exposure time of the crew to post-crash fire could be increased due to lack of markings showing location of the fire extinguisher.
3. Impact activation of the in-flight fire extinguishing system, in addition to manual activation, will improve post-crash fire protection.

RECOMMENDATIONS

Based upon the foregoing conclusions, it is recommended that:

1. One additional exterior marking be added which specifies the location of the fire extinguisher.
2. The in-flight fire extinguishing system be modified to permit activation by impact in addition to manual activation.

BLANK PAGE

EVALUATION OF CREW COMPARTMENT

GENERAL DISCUSSION

The cockpit is designed to provide maximum visibility forward and downward. Seating is side-by-side and engine controls are mounted on a center pedestal, Figure 7. The Mohawk is fitted with a control stick and rudder pedals on the left side only. However, control linkage and a stick socket are located on the right side so that the aircraft can be quickly converted to a dual-control aircraft for training or checkout purposes. In operational aircraft, location of surveillance scopes on the right side necessitates removal of the control stick. Dual instrumentation also is available for training.

The crew of the Mohawk is protected from ground fire by one-half-inch armor plate floor and removable flak curtains fore and aft in the cockpit. The plastic windshield is one inch thick.

The overall cockpit view, Figure 7, shows the compactness and the full utilization of all the available space in the Mohawk.

Noteworthy items will be covered in the close-up photographs on the following pages.

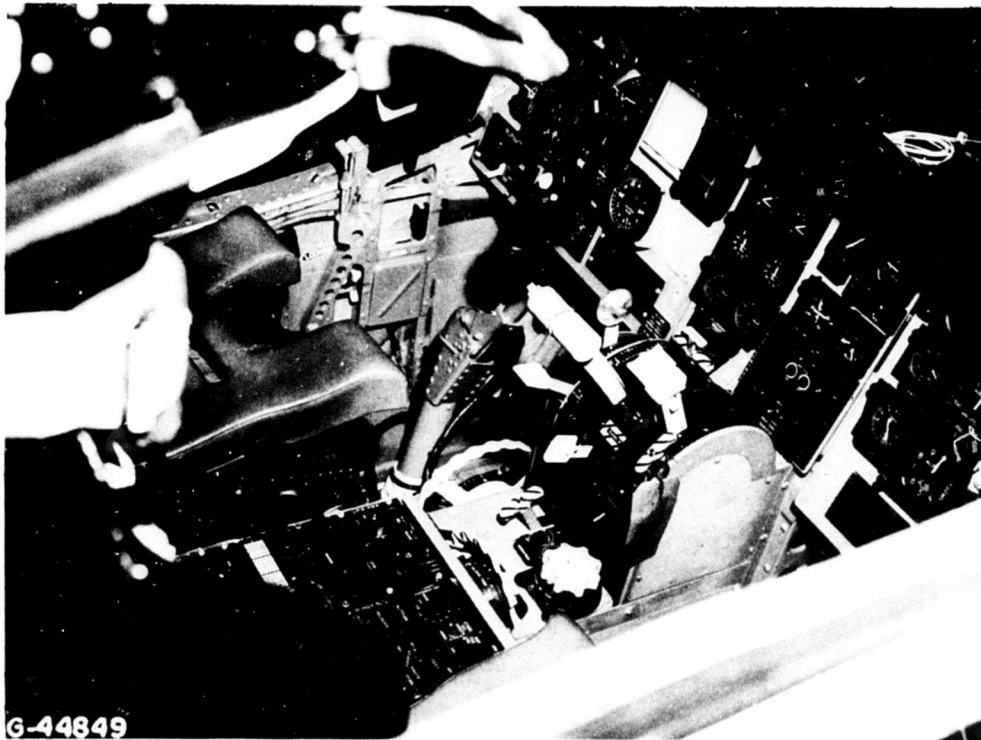

Figure 7. Overall cockpit view.

PILOT'S AND COPILOT'S SEATS

The Martin-Baker ejection seat (Figure 8) is capable of ejecting personnel at any speed ranging from 60 knots up to the Mohawk's maximum airspeed. The seat incorporates automatic deployment and seat separation devices. These ejection seats are dictated by both the low altitude tactical flying for which the aircraft was planned and the engine location aft of the cockpit, which makes a conventional bailout with engines running virtually impossible. As mentioned previously, normal ejection in the Mohawk is upward through the overhead canopy. Grumman has conducted successful tests of this type by ejecting anthropomorphic dummies through a Mohawk canopy at the Navy Air Crew Equipment Laboratory, Philadelphia, Pa.

Two desirable safety features are incorporated in the Martin-Baker seat installation: a 40 G tie-down of the seat and a continually locked shoulder harness.



Figure 8. View of the Martin-Baker seat. The arrow points out the "D" ring.

Section II

The arrow, Figure 8, points out the "D" ring which is drawn forward and downward in front of the occupant's face to fire the ejection seat. There is a possibility of this "D" ring catching on the large visor knob on the present APH-5 helmet used by the Army and thus preventing the seat from firing.

It also appears that high longitudinal decelerations could fling the "D" ring forward sufficiently to fire the seat. If this condition occurred during a crash deceleration, the occupant would not have his arms properly positioned and no doubt would sustain injuries because of the limited clearance in this aircraft. The possibility of the seat firing during high longitudinal decelerations should be carefully examined.

EMERGENCY EXITS

The open cockpit side entrances are depicted in Figure 9. These side panels are presently hinged at the top and swing outward to the position denoted by the arrow. Two steps are available on both sides to facilitate entrance and departure while the aircraft is parked. Departure while in flight is via the ejection seats. Normal entry and departure is very similar to a H-19 or H-34 helicopter. Care must be exercised, particularly by tall crew members, to avoid striking the open side panels while in the vicinity of the cockpit.

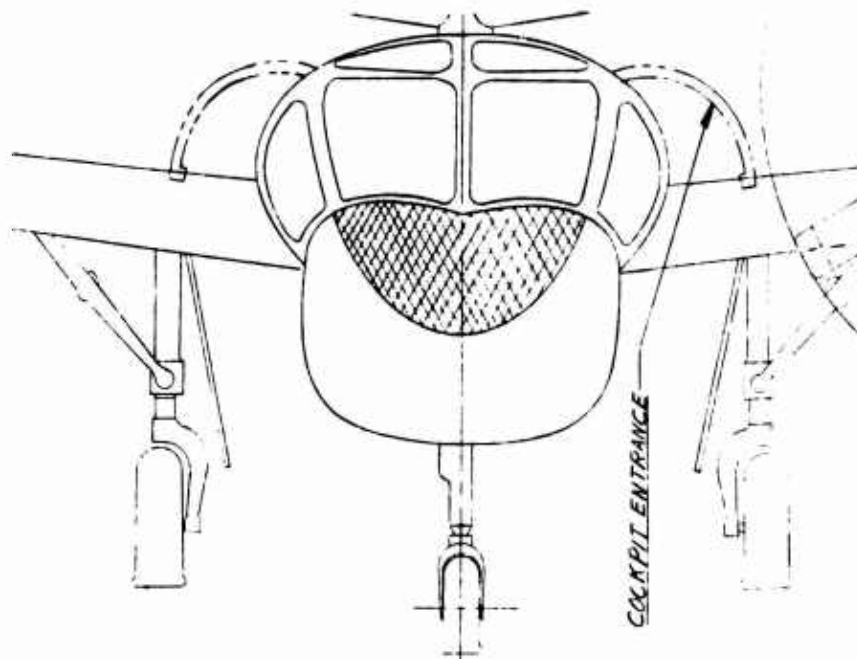

Figure 9. Front view showing cockpit side entrances. The arrow depicts the side entrances in the open position.

Section II

CREW ENVIRONMENT

The pilot's instrument panel, Figure 10, contains a large assortment of knobs, switches and protruding instruments which could produce head injuries during an accident in the event the shoulder harness and helmet were not properly utilized. A large number of sharp edges and corners are also present around the instruments. The possibility of getting all of the instruments, knobs and switches recessed or the instrument panel adequately padded is quite remote. Therefore, in order for the occupants to obtain maximum protection at all times, it must be stressed emphatically that the restraint system (safety belt and shoulder harness) plus the helmet should be utilized at all times in the prescribed manner.

The map case, located outboard of the left rudder pedal, Figure 10, appears to be an ideal location for a thermos of coffee, and it is conceivable that during turbulence or evasive maneuvers the thermos could be thrown out of the map case and jam the rudder pedals. It is suggested the map case be placarded against carrying any solid objects.

The lower portion of the instrument panel has a relatively sharp edge which could cause lower extremity injuries in the event of an accident. It is suggested that this edge be padded with energy-absorption material.

Section II

The arrow in Figure 11 denotes the side entrance opening and closing handle and is shown in the forward, or open, position. This lever, when in the locked or closed position, is directly to the left of the pilot's left arm and to the right of the other occupant's right arm and extends upward approximately three inches. This aircraft is normally flown from the left side, and it is conceivable that the pilot could catch his sleeve on this lever during violent evasive maneuvers.

It is suggested that a revised locking device be utilized to prevent interference by this device during flight and also while boarding the aircraft or deplaning.

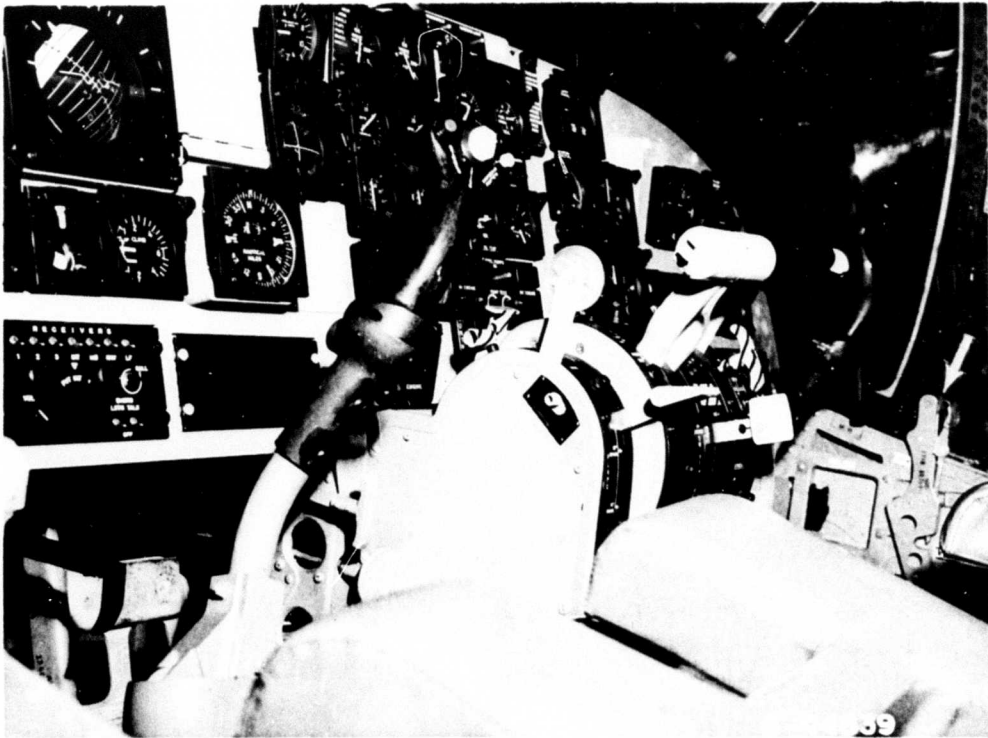

Figure 11. Close-up of the instrument panel and the center pedestal. The arrow denotes the side entrance opening and closing handle.

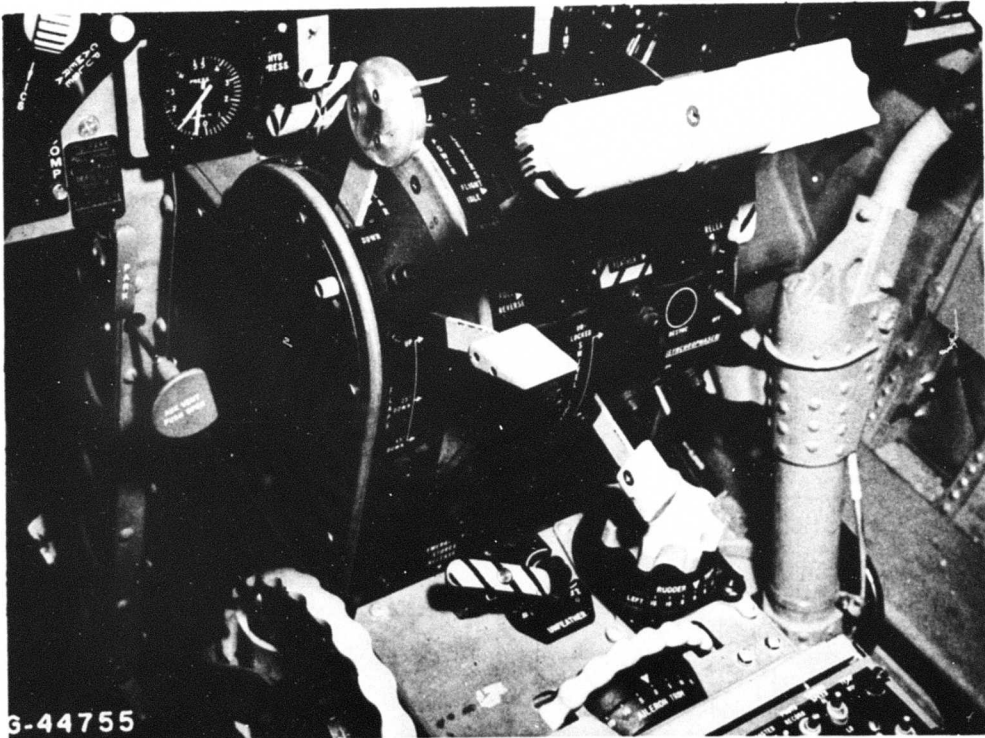

Figure 12. Close-up view of the engine control pedestal.

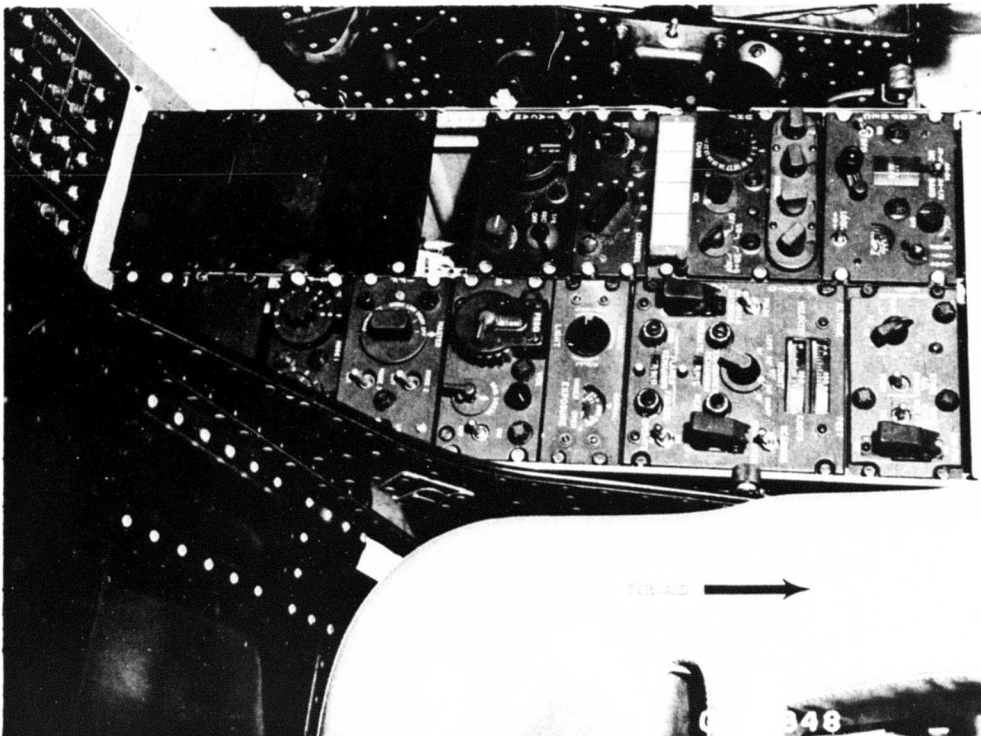

Figure 13. Radio console panel located between the occupants' seats.

Figure 14 depicts the overhead console, which is located between the two occupants. When the heads of the occupants are improperly restrained, they are within striking range of the console. Again, the possibility of getting these knobs and switches recessed is remote; therefore, it must be re-emphasized that the safety belt, shoulder harness and helmet should be worn in the prescribed manner at all times.

It should also be noted that the edges of this overhead console are quite sharp and could also produce injuries to the head in the event they were struck. It is therefore suggested that these edges be padded with a high energy-absorbing material.

The AO-1BF, when equipped with SLAR, can be flown only from the left seat, and chances are that the electronics operator will not be a qualified pilot. It is therefore imperative that the pilot not be incapacitated as a result of striking any of his environment.

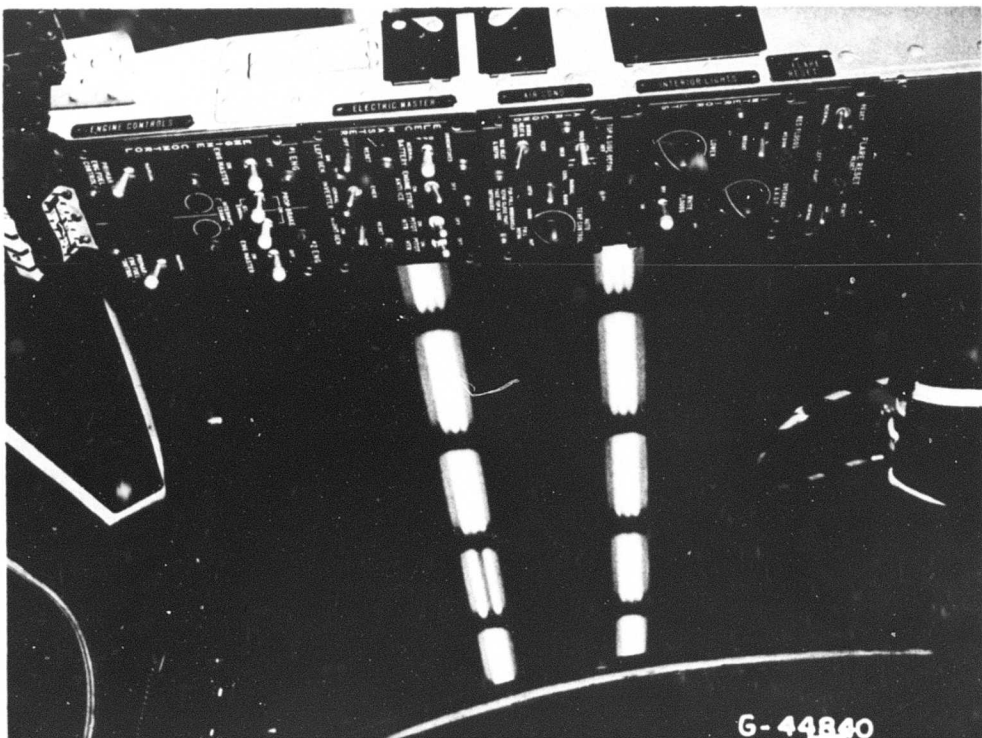

Figure 14. View of overhead console which is located between the two occupants.

Because of the addition of the electronic equipment, it was necessary to relocate some of the switches and controls. To accommodate these controls, two eyebrow panels, Figures 15 and 16, were added. These panels cover the small eyebrow windows directly above the windshield, which are depicted in Figure 9. If the restraint system and helmet are utilized, it is not likely that the occupants will strike this panel during decelerative forces. However, the lower edge of this eyebrow panel should be padded with a high-energy-absorbing material to provide protection during an ejection. It appears possible for the ejected occupant to impact this lower edge with his knee area in the event that he was not properly positioned during ejection.

The rugged light colored structure, upper right Figure 15, is the forward end of the overhead console, minus the control units and was covered on the previous page.

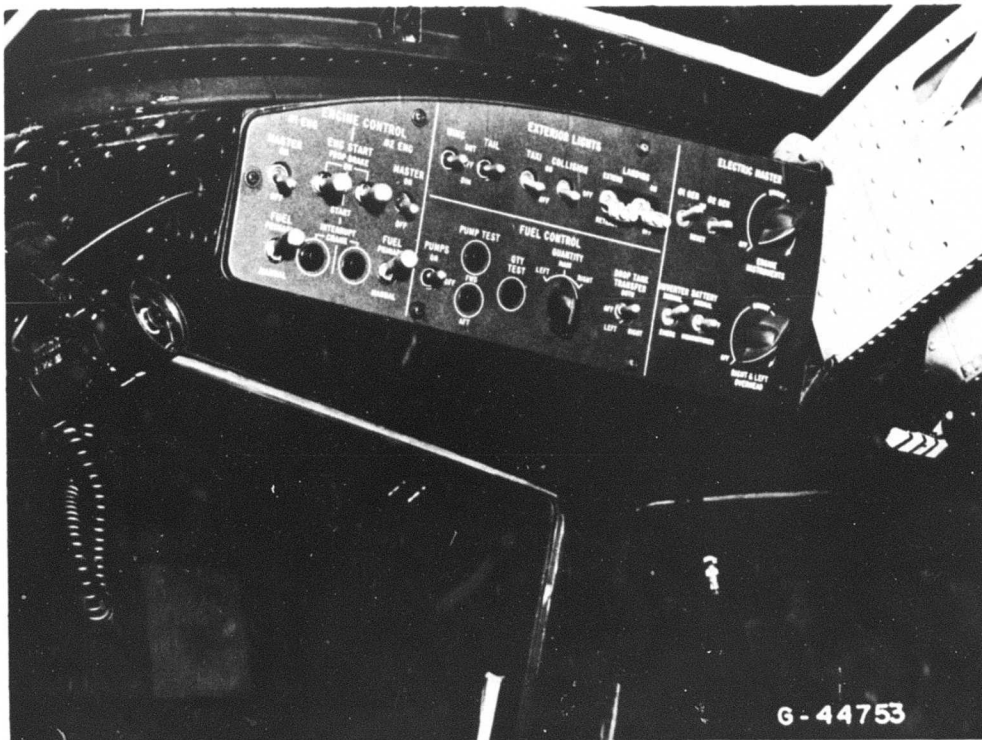

Figure 15. The left eyebrow panel is depicted.

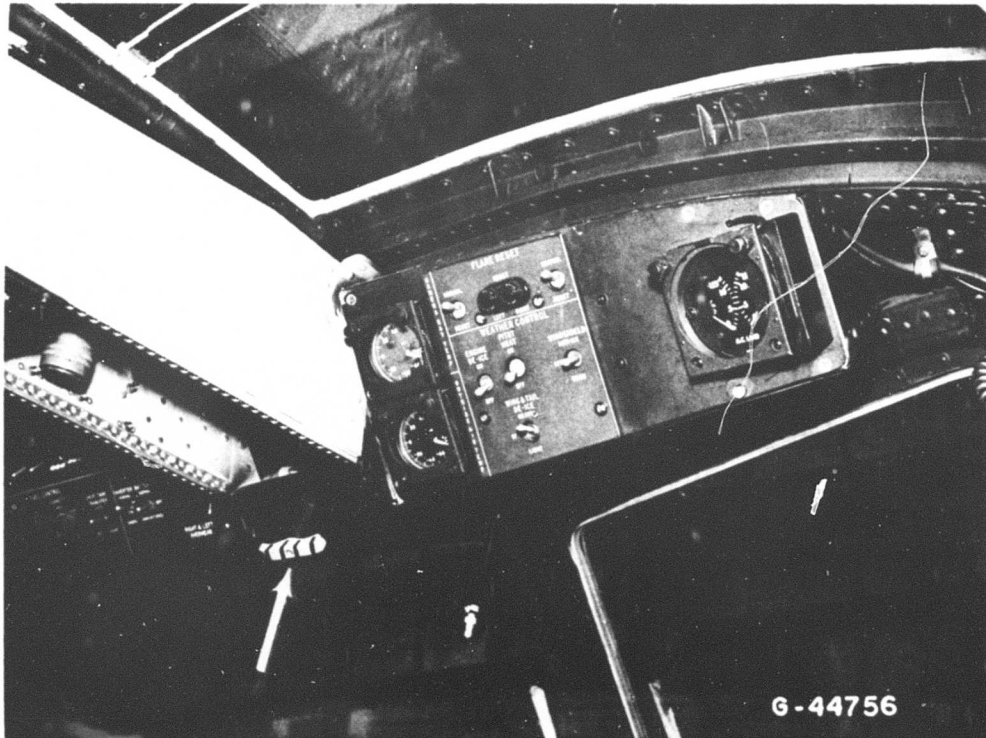

Figure 16. The arrow denotes the emergency hatch release. The right eyebrow panel is also depicted.

The overhead hatch in AO-1BF can be jettisoned from the interior only (arrow); however, this action is not a part of the firing sequence during an ejection. Normal ejection in the Mohawk is upward through the overhead canopy. Grumman advises that this method is safer than blowing off the canopy, because if the canopy jammed and was only partially blown off, the pilot's head might contact a structural bow on the canopy, which could cause fatal injury.

It is suggested that this overhead hatch be jettisonable from both the interior and the exterior to provide an additional entrance into the cockpit area for rescue personnel.

(The eyebrow panel in this photograph was discussed on the previous page.)

In order to build a cockpit to withstand 40 G, a rugged structure is necessary. Some of this ruggedness is depicted in Figure 17. The heavy structure surrounding the cockpit entrance is depicted by arrow 1, while arrow 2 denotes the entrance hatch in the open position. The sharp edges on the entrance hatch, arrow 2, could cause a very serious injury in the event they were struck.

It is suggested that these two injury potential areas be padded with a high-energy-absorption material.

The exterior lights control panel depicted in Figure 17 has been incorporated into the eyebrow panel in Figure 15.

At present, the hand fire extinguisher is located on the inside wall of the cockpit just left of the pilot's shoulder, about shoulder height. The fire extinguisher should be relocated and made accessible to either occupant while seated in the aircraft.

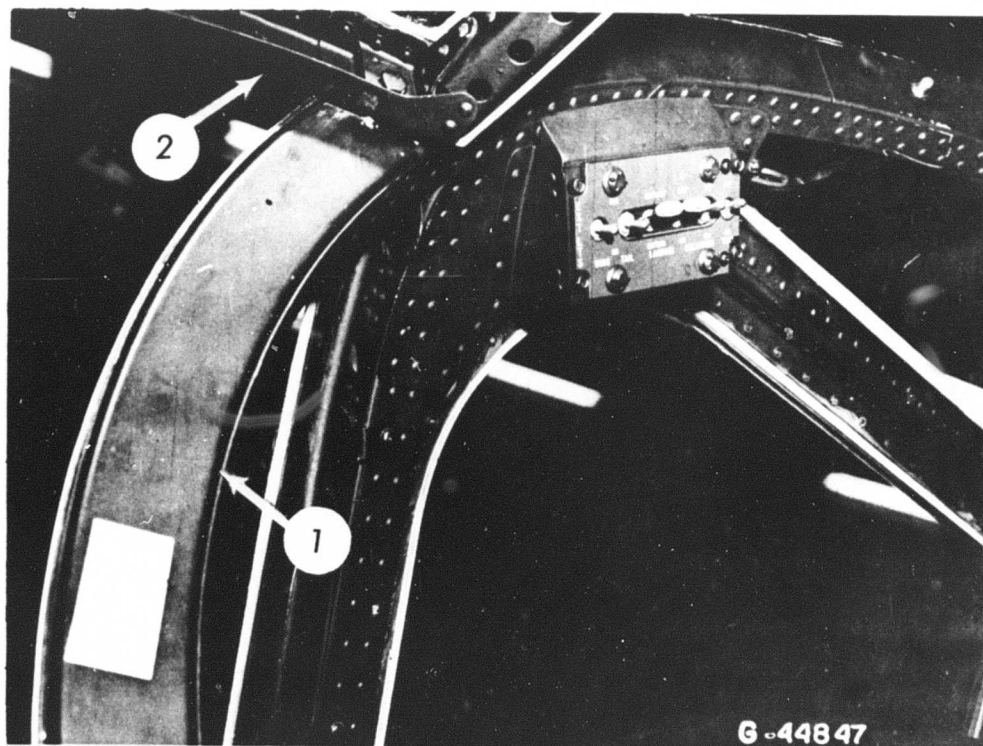

Figure 17. The sharp injury-producing edges on the side panels are denoted by the arrows.

Section II

CONCLUSIONS

After examination of the crew compartment of the Mohawk, it is concluded that:

1. The aircraft is excellent from a crashworthy point of view because:
 - a. The cockpit is stressed for 40 G.
 - b. The seat tie-down is stressed for 40 G.
 - c. The shoulder harness is continually locked.
 - d. The windshield is one-inch-thick.
 - e. The cockpit floor is 1/2 inch armor plate.
 - f. The cockpit affords excellent visibility.
2. Emergency ejection from the aircraft can be delayed if the "D" ring of the Martin-Baker seat caught the large visor knob on the present APH-5 helmet.
3. A study of the Martin-Baker seat should be conducted to ascertain the possibility of an inadvertant ejection due to high longitudinal decelerations, throwing the large "D" ring forward sufficiently to activate the seat.
4. The rescue of crew members following a crash can be hampered because the side entrance and exit panels are not jettisonable.
5. The rescue of crew members following a crash can be hampered because the overhead canopy cannot be jettisoned from the exterior.
6. Injuries can be produced by the large assortment of knobs and other equipment in the cockpit if the restraint system failed during a crash or if the hard hat is improperly worn.
7. The sleeve of either occupant can be caught on the securing lever of the side entrance and exit levers, when in a closed position, thus interfering with the safe operation of the aircraft.
8. The knee area is subject to injuries because of the unpadded lower edges of the eyebrow panels if the occupant is not properly positioned during an ejection.
9. The lower extremities can be injured by the unpadded lower edge of the instrument panel when the occupant's legs flail upward during a high longitudinal deceleration.
10. Injuries can be sustained because of the rigid structure surrounding the side entrance panels if the restraint system was not properly utilized or failed.
11. Both occupants should have ready access to the fire extinguisher while seated in the aircraft.

RECOMMENDATIONS

Based upon the evaluation of the crew compartment, it is recommended that:

1. A study be conducted to determine the possibility of high longitudinal decelerations accidentally firing the ejection seats.
2. The side entrance and exit panels be designed so that they can be jettisoned from both the interior and the exterior.
3. The overhead canopy be designed so that it can be jettisoned from the exterior.
4. The use of seat belt, shoulder harness and hard hat be made mandatory for both occupants while in flight.
5. The present side entrance securing handles be redesigned or relocated to prevent the occupant's sleeve from catching on the handle.
6. The edges of the eyebrow panels be padded, particularly the lower edge, to afford protection to the knee area in the event the occupant was not properly positioned during an ejection.
7. The lower edges of the instrument panel be padded with with a high-energy-absorbing material.
8. The rigid structure surrounding the side entrance panels be padded with a high-energy-absorbing material.
9. The fire extinguisher be relocated to a position where it is easily accessible to either occupant while seated in the aircraft.

RECAPITULATION OF CONCLUSIONS

The conclusions set forth in the two sections of this report are recapitulated here according to section headings.

BASIC AIRFRAME

After examination of the basic airframe of the Mohawk, it is concluded that:

1. The crashworthy characteristics of the basic airframe are excellent.
2. Exposure time of the crew to post-crash fire could be increased due to lack of markings showing location of fire extinguisher.

CREW COMPARTMENT

After examination of the crew compartment of the Mohawk, it is concluded that:

1. The aircraft is excellent from a crashworthy point of view because:
 - a. The cockpit is stressed for 40 G.
 - b. The seat tie-down is stressed for 40 G.
 - c. The shoulder harness is continually locked.
 - d. The windshield is one-inch-thick.
 - e. The cockpit floor is 1/2 inch armor plate.
 - f. The cockpit affords excellent visibility.
2. Emergency ejection from the aircraft can be delayed if the "D" ring of the Martin-Baker seat caught the large visor knob on the present APH-5 helmet.
3. A study should be conducted to ascertain the possibility of an inadvertent ejection due to high longitudinal decelerations, throwing the large "D" ring forward sufficiently to activate the seat.
4. The rescue of crew members following a crash can be hampered because the side entrance and exit panels are not jettisonable.
5. The rescue of crew members following a crash can be hampered because the overhead canopy cannot be jettisoned from the exterior.

6. Injuries can be produced by the large assortment of knobs and other equipment in the cockpit if the restraint system failed during a crash or if the hard hat is not properly worn.
7. The sleeve of either occupant can be caught on the securing lever of the side entrance and exit levers when in a closed position, thus interfering with the normal operation of the aircraft.
8. The knee area is subject to injuries because of the unpadded lower edges of the eyebrow panels if the occupant is not properly positioned during an ejection.
9. The lower extremities can be injured by the unpadded lower edge of the instrument panel when the occupant's legs flail upward during a high longitudinal deceleration.
10. Injuries can be sustained because of the rigid structure surrounding the side entrance panels if the restraint system was not properly utilized or failed.
11. Both occupants should have ready access to the fire extinguisher while seated in the aircraft.

RECAPITULATION OF RECOMMENDATIONS

The recommendations set forth in this report are:

BASIC AIRFRAME

Based upon the foregoing conclusions, it is recommended that:

1. One additional exterior marking be added which specifies the location of the fire extinguisher.

CREW COMPARTMENT

Based upon the evaluation of the crew compartment, it is recommended that:

1. A study be conducted to determine the possibility of high longitudinal decelerations accidentally firing the ejection seats.
2. The side entrance and exit panels be designed so that they can be jettisoned from both the interior and the exterior.
3. The overhead canopy be designed so that it can be jettisoned from the exterior.
4. The use of seat belt, shoulder harness and hard hat be made mandatory for both occupants while in flight.
5. The present side entrance securing handles be redesigned or relocated to prevent the occupant's sleeve from catching on the handle.
6. The edges of the eyebrow panels be padded, particularly the lower edge, to afford protection to the knee area in the event the occupant was not properly positioned during an ejection.
7. The lower edges of the instrument panel be padded with an energy-absorbing material.
8. The rigid structure surrounding the side entrance panels be padded with a high-energy-absorbing material.
9. The fire extinguisher be relocated to a position where it is easily accessible to either occupant while seated in the aircraft.

APPENDIX I

SUMMARY OF CRASH SAFETY CRITERIA

In its efforts to determine the crash survival aspects of aircraft accidents AvCIR, a Division of the Flight Safety Foundation, is guided by certain criteria which it considers fundamental for the crash protection of aircraft occupants. The same criteria are also used to evaluate the crash safety features of mock-ups and prototypes.

CRASHWORTHINESS

Crashworthiness may be defined as the ability of basic aircraft structure to provide protection to occupants during survivable impact conditions. Impact conditions are considered survivable in that part of the cockpit/cabin area where the crash forces are within the limits of human tolerance (with minimal or no injury)* and where surrounding structure remains reasonably intact.

Lack of crashworthiness, generally, indicates that the basic aircraft structure, seen as a protective container, is subject to extensive inward collapse thereby affecting the "inhabitability" of this area. Typical in this respect are (1) the rearward movement of the engine in single engine aircraft; (2) the downward displacement of transmissions and other heavy components in helicopters; (3) the upward collapse of lower structure into the cockpit/cabin area. This deformation or collapse of the occupiable area may result in crushing type injuries or trapping of the occupants.

When evaluating the crashworthiness of basic aircraft structure, stress is placed upon the expected behavior of this structure during a survivable type impact. Attention is also given to anticipated dynamic response under the most probable conditions of impact angle and aircraft attitude, based upon accumulated past experience. This facilitates an appraisal of the possibility of displacement of certain heavy components into the occupiable area as a result of inertia forces.

* Approximately 40 G transverse to the spine, 25 G parallel to the spine (positive G), 15 G parallel to the spine (negative G) with due consideration for peak magnitude, duration, rate of onset, and method of body restraint. J. P. Stapp, Human Exposure to Linear Deceleration, Part 2. The Forward-Facing Position and the Development of a crash Harness. Wright Air Development Center, Wright-Patterson Air Force Base, Dayton (Ohio), December 1951. A. F. Technical Report No. 5915, Part 2.

TIE-DOWN CHAIN

Although a crashworthy structure provides primary protection during a crash deceleration, injuries may still occur when occupants are allowed to come into forceful contact with their environment or to be struck by loose objects thrown through the occupiable area. The restraint system used to prevent occupants, cargo and components from being thrown loose within the aircraft is commonly referred to as the tie-down chain. The occupant's tie-down chain consists of: seat belt, seat belt anchorage, shoulder harness and anchorage, seat structure, seat anchorages and floor. Failure of any link in this chain results in a higher degree of exposure to injury.

Accident statistics indicate that the site of most serious and frequent injury in general aviation accidents is the head. In most cases, this is due to lack of restraint, allowing the head to gain momentum during impact and to strike objects in its path with a force exceeding that of the overall crash deceleration. This is especially true in the case of cockpit occupants who face the instrument panel, control wheel and many other injurious environmental structures. Considering these factors, it is practically impossible to avoid contact injuries during crash deceleration when such occupants are not restrained by a properly installed and properly used shoulder harness of adequate strength in combination with a seat belt.

Although seat structure and anchorages meet static strength tie-down requirements, failures frequently occur as a result of dynamic loads imposed by the occupants on seat belts and shoulder harnesses when these are anchored to the seats instead of primary structure. This type of crash force amplification should be taken into consideration when evaluating the dynamic strength of the occupant tie-down chain. Inadequately or improperly secured aircraft equipment and components in the occupiable area also have an injury potential during crash decelerations. Therefore, the tie-down and stowage of such items as luggage, cargo, radio equipment, fire extinguishers and tool boxes requires careful consideration.

OCCUPANTS' ENVIRONMENT

Accident experience has shown that under many impact conditions occupants who are reasonably restrained within a crashworthy structure may still receive injuries through forceful contact with injurious

environmental structures, components, etc.. (This is particularly true when shoulder harness is not used.) The freedom of movement of the occupant's body during a crash deceleration is governed by the type of restraint system installed and the manner in which it is used. Generally, it can be stated, however, that injuries resulting from the flailing action of the occupant's body show a peripheral trend; that is, the areas farthest away from the seat belt receive most of the injuries (head and lower extremities).

To preclude the probability of injury through striking injurious environment, the limitations of the restraint system should be used as a guide for the extent to which the occupant's environment should be made harmless. The injury potential of all objects and structure within striking range, omni-directionally, can be reduced to a minimum by such measures as elimination of sharp surfaces, safety-type control wheels, breakaway features in instrument panels, use of ductile or energy-absorbing material wherever possible.

TRANSMISSION OF CRASH FORCE

Another independent injury-producing factor presents itself in the fact that crash forces may be transmitted or even magnified through rigid aircraft structures. This is usually associated with "bottoming out" on structures incapable of absorbing or reducing crash force. Although crash force in most accidents is applied in a direction oblique to the occupant's spine, it is customary to resolve vertical and horizontal components of the crash force resultant and relate these to the human G-force tolerance levels, either parallel or transverse to the spine. A normally seated person, when effectively restrained by a seat belt and shoulder harness, can tolerate (with minimal or no injury) approximately 40 G transverse to the spine, 25 G parallel to the spine in the foot-to-head direction (positive G), 15 G parallel to the spine in the head-to-foot direction (negative G).

Injuries attributed solely to transverse G will seldom be encountered in aircraft accidents, because collapse of structure and/or failure of the restraint system will most likely occur before the limit of transverse G tolerance (40 G) is reached. This is an undesirable situation. Although operational and economic considerations impose limits on the overall fuselage strength, the occupant tie-down chain should be more compatible in strength with tolerance levels of the body.

Accident experience has shown that injuries directly attributed to the transmission or magnification of crash force are usually associated with predominantly vertical impacts. Vertebral injuries are most often associated with vertical crash force application.

The seat, as the occupant's supporting structure, and the underlying floor structure are the media through which vertical forces are usually transmitted to the occupant. The dynamic response of these media during an impact determines the manner in which the forces acting on the aircraft structure can be modified before reaching the occupant. An extremely rigid structure, which normally is not found in aircraft, would transmit the forces without modification. An elastic structure, which has energy-storing properties, may modify the magnitude and other characteristics of decelerative force to the extent that amplification takes place. For example, a foam rubber cushion (which does not offer an appreciable resistance to compression) allows an occupant to "bottom out" against rigid seat and seat pan structures during a vertical impact. A more desirable situation would be that in which the structure between the occupant and the point of impact had high energy-absorbing characteristics. This may be achieved by the use of structure which collapses progressively without failing suddenly. This ideal form of crash energy absorption results in attenuation of the crash forces transmitted to the occupant. It is one of the basic methods for the incorporation of occupant protection in aircraft design.

POST-CRASH FACTORS

Although a distinction could be made between the prevention of injuries sustained in the dynamic phase of the impact and those sustained in the post-crash events, it is felt that the overall crash survival concept does not allow this distinction. Past experience has shown that accidents involving only very minor impact forces can become catastrophies as a result of post-crash factors.

One of the greatest hazards in an otherwise survivable accident is the possibility of a post-crash fire. These fires, normally, are of a sudden nature and may severely restrict the time available for evacuation. According to a NACA study (Technical Note 2996) not more than 50 seconds may be available for escape in all but the most severe fires, although in some cases passengers must move away from areas of burned-through fuselage in as few as 7-1/2 seconds.

This time element becomes even more critical when occupants are handicapped by such factors as disabling injuries, stunned condition, unfamiliarity with the seat belt release or the operation of the emergency exits, being trapped, and panic.

Control of post-crash fires, to some extent, is governed by design (location of fuel cells and fuel lines in relation to electrical and mechanical ignition sources; resistance of fuel system components against rupture under conditions of moderate crash forces or distortion). Other preventive measures include location of fire extinguishers at strategic points and automatic emergency or impact-operated fire extinguishing systems.

In the event of a post-crash fire or a ditching, the ability of all occupants to timely evacuate the aircraft probably becomes the most important survival factor. The evacuation time is a function of the number, location and adequacy of the normal and emergency exits.* The location and emergency operation of normal and emergency exits should be obvious even to the non-experienced passenger. Hand or impact-operated emergency lights can be of vital importance during evacuation in conditions of darkness or subdued light.

* HIAD (the military Handbook of Instructions for Aircraft Designers) requires "a sufficient number of doors, hatches, and emergency exits to permit complete abandonment of the aircraft in the air, on the ground, or in ditching, in 30 seconds by trained personnel representing the crew and all passengers."