

AD 664644  
AD 664644

AD

**USAAVLABS TECHNICAL REPORT 67-50**

**DESIGN ANALYSIS OF  
INTEGRAL WEIGHT AND BALANCE SYSTEM FOR  
ARMY CARGO HELICOPTERS**

By

Stuart L. Varner

August 1967

**U. S. ARMY AVIATION MATERIEL LABORATORIES  
FORT EUSTIS, VIRGINIA**

**CONTRACT DA 44-177-AMC-451(T)  
NATIONAL WATER LIFT COMPANY**

**A DIVISION OF PNEUMO DYNAMICS CORPORATION  
GRAND RAPIDS, MICHIGAN**

*Distribution of this  
document is unlimited*



DDC  
JAN 2 1967  
RECEIVED  
SA

Reproduced by the  
**CLEARINGHOUSE**  
for Federal Scientific & Technical  
Information Springfield Va. 22151



**DEPARTMENT OF THE ARMY**  
**U. S. ARMY AVIATION MATERIEL LABORATORIES**  
**FORT EUSTIS, VIRGINIA 23604**

The desirability for a means by which the gross weight and center of gravity of a helicopter may be conveniently determined, prior to flight, is well established. Fixed-wing aircraft weight and balance technology has advanced to a point where on-board weighing systems are commercially available. The application of these integral weight and balance system concepts to Army cargo helicopters introduces unique problems, the solutions to which have been formulated as a result of this study. It is the opinion of this command that the present integral weight and balance system technology can support an accurate, lightweight system for use in Army cargo helicopters.

Future operational tests will provide the final answers concerning system accuracies and suitability to rotary-wing type aircraft.

Project 1F121401A254  
Contract DA 44-177-AMC-451(T)  
USAAVLABS Technical Report 67-50  
August 1967

DESIGN ANALYSIS OF  
INTEGRAL WEIGHT AND BALANCE SYSTEM FOR  
ARMY CARGO HELICOPTERS

Final Report

by

Stuart L. Varner

Prepared by

National Water Lift Company  
Instrumentation and Control Operations  
A Division of Pneumo Dynamics Corporation  
Grand Rapids, Michigan

for

U. S. ARMY AVIATION MATERIEL LABORATORIES  
FORT EUSTIS, VIRGINIA

Distribution of this  
document is unlimited.

### SUMMARY

This study covered an analysis of helicopter operational usage affecting the design, installation, and operation of an integral weight and balance system for Army cargo helicopters currently in existence and those yet in the planning stage. An analysis of existing integral weight and balance systems and their applicability to helicopter usage was also performed. A recommended general system configuration is discussed as the outcome of the previously accomplished analysis. Problems involving accurate measurement of the gross weight and center of gravity with rotor(s) in operation are discussed with the solution. The application of an integral weight and balance system to Army cargo helicopters appears to be entirely feasible.

**BLANK PAGE**

TABLE OF CONTENTS

	<u>Page</u>
SUMMARY . . . . .	iii
LIST OF ILLUSTRATIONS . . . . .	vi
LIST OF TABLES . . . . .	viii
INTRODUCTION . . . . .	1
STATEMENT OF THE PROBLEM . . . . .	3
APPROACHES TO SOLUTION . . . . .	6
Weight and Balance System Types . . . . .	6
System Operational Requirements . . . . .	9
DESIGN CONSIDERATIONS . . . . .	18
System Description . . . . .	18
Load Sensing Instrumentation . . . . .	18
Calibration Function . . . . .	31
Computer . . . . .	31
Display . . . . .	32
Pitch Sensor . . . . .	33
Control . . . . .	33
System Configuration Variations . . . . .	34
System Limitations . . . . .	44
RECOMMENDED SYSTEM CONFIGURATION . . . . .	46
Landing Gear Strut Instrumentation . . . . .	58
Terrain Slope Error in Strut Load Measurement . . . . .	73
Terrain Slope Error in Center of Gravity Readout . . . . .	74
Compensation for Terrain Slope Error in Strut Load Measurement . . . . .	76
Correction Techniques for Rotor Lift Effect During Weight and Balance Measurement . . . . .	80
Calibration/Computer Package . . . . .	84
Gross Weight and Center of Gravity Indicator . . . . .	90
Pitch Compensator . . . . .	90
Control . . . . .	93
Cargo Hook Instrumentation . . . . .	95
System Weight Estimate . . . . .	95
Power Requirements . . . . .	97
Error Analysis . . . . .	97
PROGRAM PLAN FOR ADAPTATION OF INTEGRAL WEIGHT AND BALANCE SYSTEM TO ANY ARMY GARGO HELICOPTER . . . . .	97
DISTRIBUTION . . . . .	101

## LIST OF ILLUSTRATIONS

<u>Figure</u>		<u>Page</u>
1	Hysteresis Plot — Oleo Pressure Measurement Vs. Load on Strut	8
2	Integral Weight and Balance System Block Diagram	19
3	Forces Acting on Landing Gear Strut	21
4	Vertical Load Force	22
5	Side Load Force	23
6	Drag Load Force	24
7	Scrub Turn Force	25
8	Instrumentation Application to Landing Gear — Improper Technique	26
9	Instrumentation Application to Landing Gear — Proper Technique	26
10	Terrain Slope Error in Strut Load Measurement	28
11	Strut Load Measurement Error as a Function of Pitch Attitude	29
12	Terrain Slope Error in Center of Gravity Readout	30
13	System Diagram — Manual Integral Weight and Balance System	35
14	System Diagram — Electromechanical Servo Integral Weight and Balance System, Dual Servo Diagram	36
15	Weight and Center of Gravity Indicator — Servo Display	38
16	System Diagram — Electromechanical Servo Integral Weight and Balance System, Servo and Meter Mechanism Display	39
17	Weight and Center of Gravity Indicator — Servo and Meter Mechanism Display	40
18	Weight and Center of Gravity Indicator — Dual Meter Mechanism Display	41
19	Block Diagram — Solid State Digital Weight and Balance System	42
20	Weight and Balance Remote Indicator	43
21	Integral Weight and Balance System for the UH-1	48
22	Computation of Center of Gravity for Two-Skid Landing Gear (as on UH-1)	49
23	Center of Gravity Envelope — UH-1D	50
24	Integral Weight and Balance System for the CH-54	51
25	Computation of Center of Gravity for Tricycle Landing Gear (as on CH-54)	52
26	Center of Gravity Envelope for CH-54	53
27	Integral Weight and Balance System for the CH-47	54

28	Computation of Center of Gravity for Quadricycle Landing Gear (as on CH-47)	55
29	Effect of Error in Gross Weight on Computation of Center of Gravity Location	56
30	Deflection Sensor Bar	58
31	"T" Configuration Strut	60
32	CH-47 Forward Landing Gear Strut Test	61
33	Typical Landing Gear Axle Instrumentation Hardware	62
34	"T" Configuration Strut Instrumentation Installation	63
35	"L" Configuration Strut	64
36	C-130 Main Landing Gear Preproduction Shock Test	65
37	"L" Configuration Strut Instrumentation Installation	66
38	"L" Configuration Strut with Swivel Capability and Oleo Strut Supported Drag Link Suspension	67
39	Instrumented Oleo Strut Top Cap	68
40	Four-Wheel Truck Strut	70
41	C-141 Main Landing Gear Instrumentation Test	71
42	Four-Wheel Truck Strut Instrumentation Installation	72
43	Terrain Slope Error in Strut Load Measurement	73
44	Terrain Slope Error in Center of Gravity Readout	74
45	Apparent Center of Gravity Position Change Vs. Height of Center of Gravity	75
46	Mechanization of Compensation for Terrain Slope Error	79
47	Density Altitude Vs. Lift, CH-47 Helicopter	82
48	Correction of Lift Effect — Without Density Altitude Compensation	83
49	Cockpit Display and Controls for Integral Weight and Balance System	85
50	Correction for Rotor Lift During Gross Weight and Center of Gravity Measurement	86
51	Correction of Lift Effect — With Density Altitude Compensation	87
52	System Components — CH-47 Integral Weight and Balance System	88
53	Calibration/Computer Package	89
54	Weight and Center of Gravity Indicator — Servo and Meter Mechanism Display	91
55	Pitch Sensor	92
56	Control Package	94
57	Cargo Hook Instrumentation for CH-47	96

## LIST OF TABLES

		<u>Page</u>
I	Advantages Offered by Integral Weight and Balance System for Army Cargo Helicopters	5
II	Comparison of Weight and Balance System Types	10
III	Operational Requirements for an Integral Weight and Balance System for Application to Army Cargo Helicopters	12
IV	Operation Condition Variables Affecting the Application of an Integral Weight and Balance System to Army Cargo Helicopters	17
V	Integral Weight and Balance System Component Commonality	47
VI	Lift Effect Correction Chart for CH-47A	81
VII	System Weight Estimate	95
VIII	Analysis of Integral Weight and Balance System Error (Using CH-47 Integral Weight and Balance System as Example)	98
IX	General Procedure for Application of Integral Weight and Balance System to Any Army Cargo Helicopter	99
X	Program Plan for Application of Integral Weight and Balance System to Any Army Cargo Helicopter (Typical)	100

## INTRODUCTION

From the very first days of aircraft, it has been helpful to the pilot to know the gross takeoff weight and the location of the center of gravity of his airplane. In more recent years, it has become not only desirable but also necessary for military and commercial operators of aircraft to know gross takeoff weight and center of gravity position for reasons of both safety and productivity. In recent decades, precise knowledge of these two elements has become a standard preflight requirement.

The oldest method, and the one most widely used at present, involves manual calculations based upon known aircraft characteristics and measured (or estimated) cargo and passenger weights and positions within the aircraft. Because of the cumbersome nature of the manual method and its inherent inaccuracies as a result of human error or inaccurate cargo weight and position data, the need for accurate, automatic methods for determination of gross takeoff weight and center of gravity position is well established.

Various methods for weighing loaded aircraft on fixed or portable platform scales have been tried, but with little success. Generally, the time consumed in performing this operation and the cost of the equipment have proven to be prohibitive.

As long ago as 1951, attempts were made to devise automatic on-board systems for measuring gross weight and center of gravity position for aircraft. The initial attempt generally consisted of affixing strain gauges to the landing gear; but, because of the nature of the instrumentation, it proved to be neither practical nor reliable. In 1958, Cleveland Pneumatic Tool Company, the world's largest manufacturer of landing gear, attempted to devise a system based on measurement of the pressure in the oleo struts of the landing gear. However, because of the friction inherent in oleo strut operation, it was concluded that any system based on this principle was bound to give erratic results. Thus, this approach was abandoned.

In 1959, the Instrumentation and Control Division of Pneumo Dynamics Corporation, working with its sister division, the Cleveland Pneumatic Tool Company, began the development of a weight and balance system based on strain sensing within the landing gear structure, utilizing a newly developed sensor. These efforts culminated in the first successful aircraft integral weight and balance system which was installed and tested in 1964 in two USAF C-130 aircraft. In December 1964, the Instrumentation and Control Division merged with the National Water Lift Company, also a Division of Pneumo Dynamics Corporation. In June 1966, the automatic integral weight and balance system became an operating reality with the first production article installation of the Pneumo Dynamics Corporation

system in USAF C-130 aircraft.

Since the history of practical rotary-wing aircraft is considerably shorter than that of fixed-wing aircraft, the efforts toward development of an on-board weight and balance system for helicopters are of shorter duration; however, the need is certainly no less critical, and, under some conditions, it undoubtedly is more critical than the requirements on fixed-wing aircraft. Fortunately, there is no reason why the experience and techniques developed for fixed-wing aircraft cannot be applied directly to rotary-wing aircraft. However, there are substantial differences in application and use, and several new factors are introduced.

This report covers the results of a study performed by the National Water Lift Company under Contract DA 44-177-AMC-451(T) for the U. S. Army Aviation Materiel Laboratories, Fort Eustis, Virginia. The initial phase of the study was an investigation of the operational aspects of helicopter usage with respect to the application of on-board weight and balance systems. Next, based on information gathered in the operational investigation, National Water Lift Company performed an engineering analysis of the general application of integral weight and balance systems to Army cargo helicopters. Finally, as an outcome of the previous efforts, a general recommendation as to the configuration of a helicopter integral weight and balance system is provided, and a discussion of the potential problem areas and their solutions is given.

This report therefore recounts the need for weight and balance information in rotary-wing aircraft; it examines the aircraft features and the various basic methods potentially capable of generating this information; it analyzes the instrumentation available for performing the necessary measurements and computations; then it prescribes a recommended system.

## STATEMENT OF THE PROBLEM

With an accurate knowledge of cargo helicopter gross weight and center of gravity conditions, measurable improvements are derived in both safety and productivity. Therefore, the existing complement of cargo helicopters and their flight crews can be conserved, while at the same time their assigned tasks can be performed with greater efficiency.

Drastic improvements in safety are seen in takeoff, in flight and landing modes, in minimizing exposure of men and machine to enemy fire under combat conditions, and in minimizing the effect of structural fatigue induced by operation at extreme balance conditions.

The critical takeoff phase of helicopter operation can be conducted with maximum safe loads, while at the same time aerodynamic stability can be maintained when accurate gross weight and center of gravity information is available. This capability is particularly desirable under adverse density altitude conditions under which normal load-carrying capabilities are reduced.

Maximum flight performance capability is a direct outcome of the knowledge and control of gross weight and center of gravity in a helicopter. Knowledge of this important weight and balance information enables avoidance of aerodynamic stability problems such as blade stall at high airspeeds and gross weight.

Accurate preplanning of helicopter capabilities at an intended landing site is facilitated by the accurate gross weight and center of gravity information obtained prior to takeoff. That is, the capability to make a hover approach or the necessity to land with forward speed can be preplanned.

An obvious advantage of an integral weight and balance system aboard Army cargo helicopters is the ability provided to load to optimum weight and balance conditions in an absolute minimum of time. The reduced exposure of helicopters and flight crews to enemy fire, while certainly to be categorized as a flight safety item, must also be considered in the light of the increased potential productivity.

An important facet of the use of an integral weight and balance system in the loading of Army cargo helicopters is the reduction in structural fatigue which results from operation at extreme balance conditions. With accurate weight and balance data and the use of the integral system, loading can be accomplished at more nearly nominal conditions of center of gravity.

As illustrated above, the aspect of safety is interrelated with that of

productivity. Numerous benefits in the area of productivity accrue from the use of an integral weight and balance system on Army cargo helicopters. Areas of benefit are seen in the reduction of materiel handling time, in the reduction of cargo loading time, in the utilization of full load capabilities, and in the provision of optimum aerodynamic trim and thereby maximum flight range or duration.

Delays in the movement of helicopter-borne cargo can result from the necessity to weigh individual items at the depot from which shipment is being made. The manpower required to perform the weighing operation and also much of the weighing equipment itself could be utilized for other purposes with the availability of an integral weight and balance system for Army cargo helicopter use.

Loading time at a depot or in the field is considerably reduced by using the integral weight and balance system to control load quantity and positioning. The time thus saved can be utilized in the flight task for which the helicopter is intended.

On each flight of a helicopter equipped with an integral weight and balance system, the maximum safe load for the conditions to be encountered can be carried. Estimation of helicopter load on the "safe side" results in an unnecessary reduction in productivity, while load estimates on the "high side" can cause operation under over-load conditions with attendant aerodynamic and structural problems induced.

Weight and balance control of helicopter loading with an integral weight and balance system enables flight operation under more nearly optimum aerodynamic conditions. Optimum trim results in reduced fuel burn-off rate, with the direct result being increased flight range and duration.

Using integral weight and balance systems, the current lift capability can be maintained by fewer helicopters and personnel, or an improved lift capability can be provided with the present complement of equipment and crew.

The magnitude of the problems currently existing with the lack of accurate knowledge of helicopter gross weight and center of gravity information, while large, can be reduced to a great extent with the application of an integral weight and balance system. The benefits in the areas enumerated above will have a major impact on the overall capabilities of Army cargo helicopters — both individually and collectively.

The advantages offered by the application of integral weight and balance systems to Army cargo helicopters are summarized in Table I.

**TABLE I**  
**ADVANTAGES OFFERED BY INTEGRAL WEIGHT AND BALANCE SYSTEM**  
**FOR ARMY CARGO HELICOPTERS**

<b>SAFETY</b>	Takeoff	Maximum safe loads carried Maintains aerodynamic stability
	Flight	Maximum performance Avoidance of aerodynamic instability
	Landing	Preplanning of helicopter capabilities at intended landing site
	Combat Operation	Absolute minimum of time required in loading Reduced exposure of men and equipment to enemy fire
	Structural	Enables operation at more nearly nominal center of gravity Reduces structural fatigue
	Materiel Handling	Eliminates need for depot weighing of cargo Releases men and equipment for other tasks
	Loading Task	Minimum time required Increases availability for flight task
	Cargo Load	Eliminates errors in estimated weight and position Maximum cargo-carrying capability every flight
	Aerodynamic Trim	Reduced fuel burn-off rate Improved flight range and duration
	Air & Ground Crew	Fewer helicopters operating more efficiently can perform given lift task Reduced requirement for trained crews
<b>PRODUCTIVITY</b>		

## APPROACHES TO SOLUTION

The types of weighing systems which can be employed in the control of helicopter weight and balance are described in this section. System operational requirements are also discussed.

### WEIGHT AND BALANCE SYSTEM TYPES

The diversified methods or systems by which control of helicopter weight and balance is maintained range from the manual computation of weight and balance using weighed or estimated cargo load data, through on-site cargo weighing equipment and aerodynamic feel employed by the pilot at takeoff, to equipment installed on board the helicopter which is available for use at any time.

#### Manual Computation

The standard method for the control of helicopter loading is currently the manual computation of weight and balance. With this system, the basic weight of the aircraft and its accessories is known and entered in the computation form. Other weights and their moments are entered for computation of center of gravity. Often, a major error in the estimation of cargo weight exists, particularly in field operations. The improper loading which can result from these errors causes the helicopter to be operated in an inefficient or even a dangerous manner.

#### On-Site Weighing Equipment

Platform-scale-type weighing equipment is generally available for cargo load control at the larger depots from which cargo helicopters operate. As discussed previously, delays in loading and transporting cargo can result from the necessity to weigh materiel prior to loading. Further, platform-scale weighing equipment is generally not available in the field due to its cumbersome nature. Thus, the use of platform scales cannot be considered the answer to the necessity to weigh cargo in the control of helicopter loading.

#### Aerodynamic Feel

The aerodynamic feel characteristic of the loaded helicopter is naturally taken into account by the pilot in all flight operations. Obviously, this technique is commonly used (more effectively by more experienced pilots) to cross-check manually computed weight and balance characteristics. While this method provides a minimal check on helicopter loading conditions, it cannot be relied upon for a more extensive role.

### On-Board Weight and Balance Measurement Equipment

The strong desirability to make the weight and balance control equipment an integral part of the helicopter is evident in consideration of the advantages to be gained. With the weight and balance control equipment made integral with the helicopter, measurements can be made at any landing site. The equipment capable of providing load measurements must measure either landing gear loads or dynamic loads in the rotor system.

Measurement of rotor system dynamic loads is drastically limited in its capability, providing no static measurements or center of gravity computations. With this technique, measurements are made of lift forces on the support structure for the rotor head or of forces in the rotor drive train. The limitations of this system make it unsuitable for operational control of helicopter weight and balance.

When compared with the previously described methods, it is seen that the instrumentation of the landing gear struts remains the only practical technique to be employed in the measurement of helicopter weight and balance. Instrumentation of the landing gear struts enables measurements of helicopter load and load distribution at any time that the helicopter is on the ground. No cumbersome platform scales need be used in the measurement of individual items of cargo.

The accuracy of the system which instruments the landing gear strut loads can vary widely with the instrumentation technique employed. The two general instrumentation methods applicable to landing gear strut load sensing are the measurement of oleo strut pressure versus load and the measurement of mechanical deflection of the strut versus load.

The strut instrumentation method which applies a pressure transducer at the oleo strut for measurement of pressure versus applied load is highly unsuitable for use on a helicopter which operates on nonlevel terrain in the field. Testing performed by the Instrumentation and Control Operations of National Water Lift Company at the facilities of the Cleveland Pneumatic Tool Company on pressure transducer instrumented struts under idealized conditions showed poor results. With the struts mounted vertically in a test machine with roller plates mounted under the wheels in both the fore-to-aft and side-to-side directions in order to eliminate side forces, a hysteresis in the pressure transducer output of 10% to 15% was seen, as shown in Figure 1. With the strut positioned nonvertically and with side loading, as in operational helicopter use, the frictional forces tending to bind the strut would have been greatly increased. Measurements with error of this magnitude cannot be considered useful in a weight and balance system for application to Army cargo helicopters.

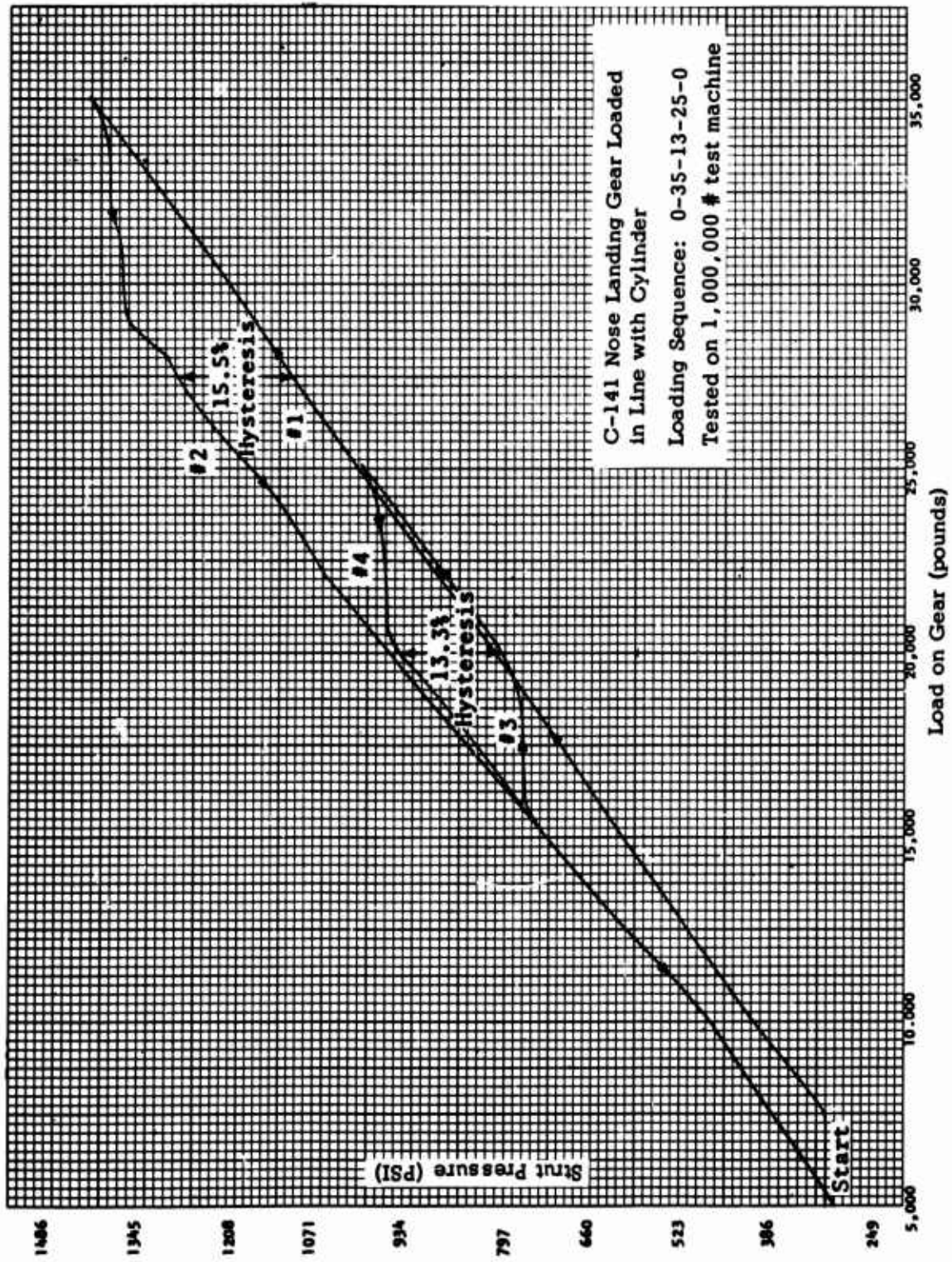

Figure 1. Hysteresis Plot — Oleo Pressure Measurement Vs. Load on Strut.

Measurement of the load on helicopter landing gear struts by sensing the deflection of structural members is desirable in that the variable oleo strut bearing friction does not affect the measurement. The instrumentation, if applied properly, is capable of accurately measuring the individual strut load under the widely varied conditions encountered by Army cargo helicopters. This instrumentation, as part of the integral weight and balance system carried aboard the helicopter, is immediately available at any landing site to provide accurate measurement of helicopter gross weight and center of gravity.

Table II provides a comparison of the weight and balance system types previously described.

#### SYSTEM OPERATIONAL REQUIREMENTS

The user of an integral weight and balance system aboard a helicopter needs accurate data displayed in a usable manner for the control of loading. The equipment must enable rapid determination of quantity and placement of cargo.

The display and the control package should be of a size and configuration that can be mounted so as to be directly accessible to the pilot. The computer package need not be mounted in the cockpit area, but should be accessible to the crew in flight for system test purposes. In addition to landing gear strut instrumentation, loads on high-capacity hoists or cargo hooks should be sensed and displayed on the weight indicator. Both the display package and control should be self-illuminated to provide optimum readability.

The integral weight and balance system, to be fully useful, should be capable of providing accurate static weight and balance readings. This accuracy under static conditions is important to enable loading operations to be completed without the necessity for rotor operation to break strut friction. In addition, an accurate gross weight and center of gravity reference is provided for measurement during rotor operation. Full correction for the rotor lift effect during weight and balance measurement must also be provided. Full lift correction must account for helicopter rotor lift at the site of the initial compensation and for the variation in that lift to be encountered at subsequent landing sites having a density altitude variance.

Environmental requirements for the integral weight and balance system must be tailored to the temperature, vibration, shock, altitude, and attitude conditions encountered in Army cargo helicopter operations.

TABLE II  
COMPARISON OF WEIGHT AND BALANCE SYSTEM TYPES

SYSTEM TYPE	ACCURACY	MOBILITY	ADVANTAGE	DISADVANTAGE
Manual computation	Dependent upon accurate knowledge of cargo weight	Good	Simple	Inaccuracy in field without measured cargo weight. Subject to human computational errors
Preweigh at depot	Good, but subject to change after weighing (water absorption, e.g.)	Not available at forward areas	Accurate at time of measurement — when available	Weighs only cargo at depot, not in field; no GW & CG of helicopter measured
Platform scale on site	Good	Poor, heavy equipment — hard to set up quickly	Accurate, but limited to cargo in practical application	Cumbersome equipment for field use; no GW & CG of helicopter measured
Aerodynamic Feel	Dependent upon experience and judgement of pilot	Good	Cross-check	Potential inability to recognize dangerous condition
Oleo pressure	Questionable, subject to strut friction error	Good, on site with helicopter	Immediate measurements — always available	Relatively inaccurate compared to strain sensor type in both static and dynamic weighing
Strain sensor	Good, nominally 1% GW & CG	Good, on site with helicopter	Immediate accurate measurements — always available	Cannot weigh with flotation existent
Rotor Dynamics	Good, but no static measurement	Good, on site with helicopter	Available when rotors are operating	No static measurement, no CG measurement

In designing the equipment for installation on helicopters, one must take into account the conditions encountered in both factory and field installation, calibration, and overhaul.

Special consideration must be given the landing gear configuration to be instrumented in each application.

Table III provides a summary of the operational requirements for an integral weight and balance system for application to Army cargo helicopters.

#### Operational Considerations

The application of an on-board weight and balance system to Army helicopters requires a complete understanding of the environment in which operation is required. In order to gather the store of information needed in the analysis of the application, National Water Lift Company has interviewed personnel associated with helicopters in the areas of flight operation, safety, training, maintenance, design, construction, and test.

A conference held at Fort Rucker, Alabama, provided a major contribution regarding the effect of helicopter operational procedures on the application of integral weight and balance systems. Rated personnel from the Army Board of Aircraft Accident Review, the U. S. Army Aviation Test Board, and the Department of Rotary Wing Training at Fort Rucker; a technical representative from Boeing-Vertol; and engineers from National Water Lift Company attended. A broad range of experience was available, ranging from that of several recently rotated helicopter pilots from the Vietnam combat area, through experience in flight test, training and safety. The viewpoint of a helicopter manufacturer's technical representative and the National Water Lift Company perspective on the weight and balance system application were also drawn upon in the discussions.

A résumé of the information obtained in this conference which is particularly pertinent to operation in combat zones follows.

- (a) Cargo in these areas is not weighed. No idea exists as to an accurate gross weight figure or center of gravity location.
- (b) The above condition is coupled with the necessity to land quickly, to discharge passengers and cargo, to reload quickly, and to lift off. Operation under fire makes a fast, accurate system for measuring weight and balance highly attractive.
- (c) As a result of the desirability to alight, discharge, reload, and lift off quickly, it is common practice to perform the loading operation

TABLE III

OPERATIONAL REQUIREMENTS FOR AN INTEGRAL WEIGHT AND BALANCE SYSTEM FOR APPLICATION TO ARMY CARGO HELICOPTERS

COMPONENT REQUIREMENTS	Display and Control Package	Size and configuration to enable mounting accessible to pilot Internally illuminated, usable display
	Computer Package	Accessible to crew in flight for test Replaceable without recalibration
	Strut	Measure ground loads
	Instrumentation	Sensors replaceable without recalibration Display individual sensor or strut outputs for test
CORRECTION REQUIREMENTS	Cargo Hook or Winch Instrumentation	Measure cable suspended load
	Rotor Lift	Display individual tension on multicable designs
	Density Altitude	Correct weight and CG computations for rotor lift effect
	Attitude	Correct lift compensation for density altitude gradient
	Temperature	Correct pitch attitude induced measurement error
	Field Retrofit	Provide integral compensation in system components Minimum tooling required for field installation Minimum out-of-service time
	Factory Installation	Provide instrumented, precalibrated strut components where possible Minimum installation time
INSTALLATION REQUIREMENTS	Overhaul	System components readily removed, tested and refurbished
	Maintenance	Integral system test capability Replaceable components, modular plug-in construction

with the rotors running at flight-operating RPM and minimum collective pitch (conditions under which an integral weight and balance system would be required to function accurately, as well as under static conditions). Relatively high lift is attained under this condition and must be accounted for if accurate weighing is to be possible. The magnitude of this lift produced for the CH-47A Chinook, for example, is on the order of 6000 pounds.

- (d) Operation on nonlevel terrain is quite common and is always approached to maintain a level lateral condition. Accommodation of slopes as high as  $10^\circ$  is possible. Major errors in the location of longitudinal center of gravity position would result if compensation were not provided.
- (e) Operation with water landings is performed with reduced gross weight limits. For example, for the CH-47A Chinook, a 28,000-pound maximum limit is imposed rather than the normal 33,000-pound limit.
- (f) Cargo hook load readout, as planned for the CH-47A, would be desirable. No center of gravity reading is needed in this readout mode.
- (g) Readout of center of gravity position should be made in terms of fuselage station.
- (h) Certain smaller helicopters such as the UH-1 series are critical as to gross weight and center of gravity location and should be considered for application of the integral weight and balance system.
- (i) Load suspension systems using a single hook or cable do not adversely affect center of gravity position in that the cable is normally located at the nominal center of gravity, and the suspended load, being pendulous, locates its center of gravity directly below the attach point. In the conference, mention was made of multicable support systems now used on the CH-54 Skycrane and under consideration for use on the heavy lift helicopter. With this support technique, support cable tension can be measured by integral weight and balance system components for load readout and equalization.

#### Operating Characteristic Demonstration

Demonstration of helicopter operating characteristics was made at Fort Rucker using a CH-47A Chinook. The previous statement of the personnel in the conference that the rotors provided lift in even the ground-idle condition was borne out, as the fuselage was seen to lift as rotors were

brought up to ground-idle RPM. Increasing rotor speed through flight-idle RPM to operating RPM produced an increasing lift effect. The capability to vary the lift distribution from the forward to aft rotors by use of the cyclic stick was also demonstrated.

Attention was given the landing gear struts during the demonstration to roughly determine the effect of strut friction on the ability of the struts to follow loading changes. No motion was observed on the struts until the cyclic stick was exercised, varying the distribution of collective pitch applied to the forward and aft rotors. It would appear that the strut friction magnitude on this helicopter would preclude the use of strut pressure variations in the measurement of loading.

#### Operational Variables

Operational variables encountered in the helicopter application are listed below and are seen to have major importance in the determination of requirements for an integral weight and balance system for helicopter use.

#### Rotor Condition

- (a) Power off, no rotation
- (b) Fixed RPM and specific pitch
- (c) Any RPM and any pitch

With power off and no rotor rotation, no lift results; thus, the helicopter weight and load distribution can be determined solely by the instrumentation of the landing gear (assuming that no loading ramps are in contact with the ground).

In weighing the helicopter with the rotor at a fixed RPM and a specific pitch setting, the resulting lift must be compensated for by adjustments in both gross weight and center of gravity readings, preferably by reference to accurate static readings or, less accurately, by tables correlating the error and the variables involved. Again, instrumentation of the helicopter need only involve the landing gear struts.

If we desired to obtain a helicopter weight reading at any rotor RPM and any rotor pitch setting, we must then assume that the vehicle is completely supported through the landing gear struts on the ground or that it is partially supported by the ground and partially supported by the rotor plane or that it is completely supported by the rotor plane. In this case, we must instrument both the landing gear struts and the rotor support structure. An accurate weight can then be obtained by the algebraic addition of the landing gear

instrumentation signals and the signals from the rotor support plane. This system seems far too complicated to be justifiable.

#### Landing Surface Conditions

- (a) Hardness
- (b) Frictional conditions
- (c) Level condition
- (d) Water cover
- (e) Motion

The hardness or frictional characteristics of the surface alighted upon can have an effect on the deflection of landing gear strut structure and thereby can impose certain requirements on the instrumentation employed therein. Landing on an unlevel surface causes changes in the measurement and distribution of weight on the landing gear struts and, if not compensated for, results in errors in gross weight and center of gravity readings. Unlevel terrain causes an appreciable increase in the friction level seen in the landing gear oleo struts.

In those cases where a helicopter lands in water, the partial or full buoyancy effect takes over the support of the helicopter from the landing gear struts. Finally, we must consider that the surface on which the helicopter is to land can be in motion, as the deck of a ship. The accelerations imposed by the moving deck on a helicopter which has landed can be appreciable in their effect on weight and center of gravity readings.

#### Temperature and Altitude Conditions (Density Altitude)

Both of the above conditions modify the lift capability of helicopters. These parameters must be known or measured to fully correct rotor lift effect during weighing at landing sites having a variation in density altitude from that at the origin of the mission.

#### Wind Condition

- (a) Weight transfer
- (b) Lift (positive or negative)

The magnitude of lateral weight transfer from wind loading is considerably higher than that of longitudinal weight transfer as the result of the relatively large side area of the helicopter compared to its frontal area. The resulting small longitudinal weight transfer from winds up to 30 knots induces a negligible error in the center of gravity reading. The lateral weight transfer, while readily measurable, has no effect on longitudinal center of gravity.

No requirement is seen for readout of lateral center of gravity position in the CH-47, the UH-1, or the CH-54. Side area of the CH-54 is small; therefore, wind produces minimal lateral weight shift. Individual hoist cable readout may be desirable for cable tension regulation.

#### Fuel Slosh

Weight transfer as a result of fuel slosh with pitch attitude of the helicopter is not seen as a problem in the UH-1, the CH-47, and the CH-54, according to manufacturing and military project office personnel. Attention is given to center of gravity control in the design and placement of fuel tanks for helicopter application.

#### Service History of Equipment

The condition of the helicopter and its critical components with regard to amount of service usage or damage can have a major effect on the limits applied to gross weight and center of gravity position. This modification to existing limits by the responsible pilot is a matter of judgement. As an example, a rotor blade known to have sustained damage in a combat situation might well cause the pilot to reduce his load and, further, to favor the potentially weakened component with a change in center of gravity.

TABLE IV  
OPERATION CONDITION VARIABLES AFFECTING THE APPLICATION  
OF AN INTEGRAL WEIGHT AND BALANCE SYSTEM TO ARMY CARGO HELICOPTERS

ROTOR CONDITION	Power Off	Accurate measurement of loads on struts enables accurate computation of weight and CG.
	No Rotation	Rotor lift must be compensated for in GW.
	Fixed RPM	Rotor lift moments must be compensated for in GW.
	Specific Pitch	Complex instrumentation requires algebraic summation of strut loads and rotor lift.
	Any RPM	Can affect loading of struts.
	Any Pitch	Requires insensitivity to loads nonperpendicular to ground.
LANDING SURFACE CONDITION	Hardness	Can affect loading of struts.
	Friction	Requires insensitivity to loads nonperpendicular to ground.
	Levelness	Can affect loading of struts.
		Requires insensitivity to loads nonperpendicular to ground.
		Pitch attitude departing from level by more than 3° or 4° requires correction of cosine function load measurement error and tangent function apparent CG shift.
		Partial or full flotation relieves load supported by struts and causes measurement error.
TEMPERATURE AND ALTITUDE CONDITION	Water Cover	Acceleration imparted to helicopter by landing surface (as deck of ship).
	Motion	Lift gradient vs. density altitude requires correction.
	Density Altitude	Correction made by chart or manual or automatic system input.
	Temperature and Altitude Extremes	Minimal effect on temperature compensated system and components. Requires accommodation in design.
WIND CONDITION	Weight Transfer	Minimal longitudinal weight transfer.
		Appreciable lateral transfer dependent upon side area and cross wind vector — no lateral CG measurement.
FUEL SLOSH	Lift	Minimal effect.
	CG Shift	Minimal effect.
SERVICE HISTORY OF EQUIPMENT		Design and placement of tanks carefully engineered.
	Decrease Load Limit	Prudent, willful decrease in load limit to accommodate known structural weakness.
	Decrease CG Range	Prudent, willful decrease in CG range to accommodate known structural weakness.

## DESIGN CONSIDERATIONS

### SYSTEM DESCRIPTION

An integral weight and balance system applicable to cargo type helicopters will be comprised of the following components, as shown in Figure 2:

- (a) Sensing instrumentation (load and pitch attitude)
- (b) Calibration elements
- (c) Computer
- (d) Display

Electrical signals analogous to vertical load on the landing gear struts must be provided in the system. These signals must be standardized as to scale factor, either at each individual strut or in a central calibration package. The computation of gross weight and center of gravity is accomplished in a computer section utilizing the standardized strut load signals. Outputs of gross weight and center of gravity are fed from the computer package to suitable indicators, which can be packaged with the computer or provided as remote displays.

### LOAD SENSING INSTRUMENTATION

An area of major concern in an integral weight and balance system is the long-term repeatability of the landing gear instrumentation. The system load sensor outputs must be stable with respect to environmental variations such as temperature, vibration, and shock over protracted periods between calibrations. The effect of the various nonvertical loads which can be imposed on landing gear struts must be effectively rejected in order to achieve a usable level of accuracy in the instrumentation signals. Additionally, the landing gear load instrumentation must be capable of accurate measurement under static conditions in order to enable loading operations to be accomplished with simultaneous accurate weight and balance measurement without the need for rotor operation to break strut friction. Further, accurate static measurement provides a necessary reference for use when weighing during rotor operation.

The load sensing instrumentation employed on struts or crane hooks can be one of the following types:

- (a) Deflection sensor device
- (b) Directly applied strain gauges (measuring structural strain)
- (c) Pressure transducers (measuring landing gear oleo strut pressure)

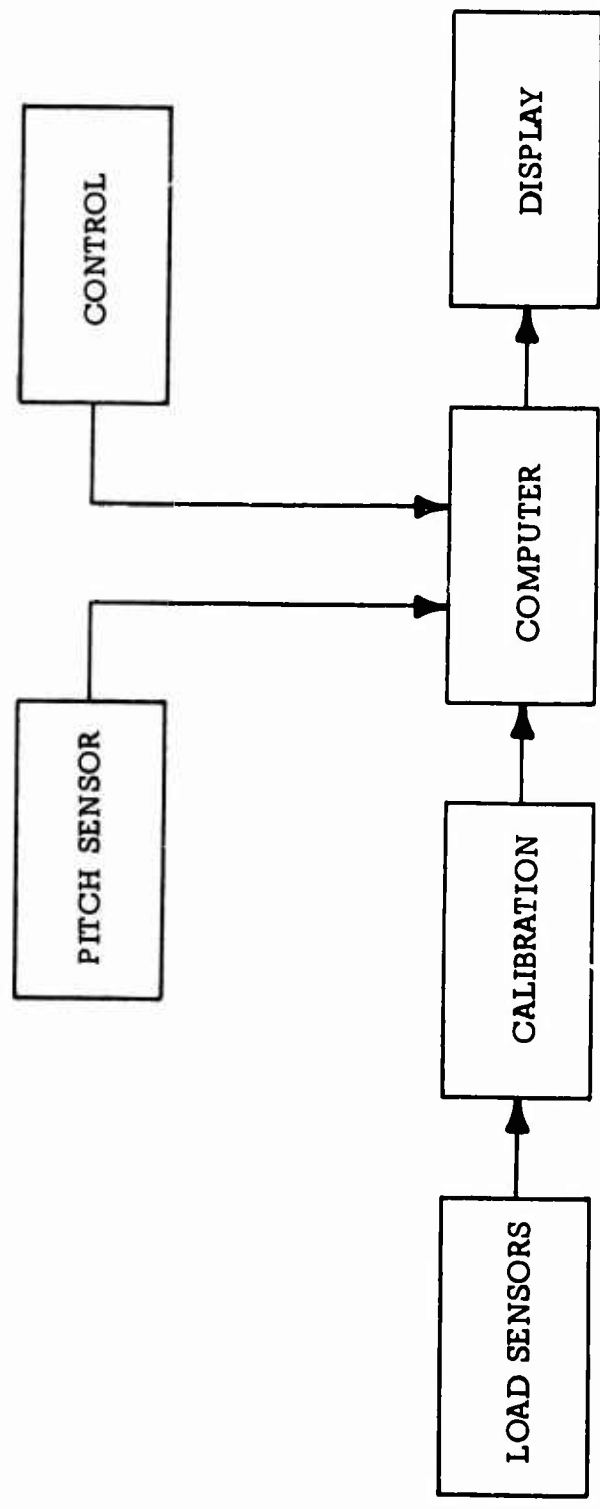

Figure 2. Integral Weight and Balance System Block Diagram.

The deflection sensing devices employed in the instrumentation can be of semiconductor strain gauge type, conventional foil or wire strain gauge type, or electromagnetic devices such as the linear-variable-differential transformer (LVDT) or reluctance pickoff. Semiconductor strain gauges offer electrical outputs which are on the order of 20 to 30 times those provided by foil or wire types, thereby greatly enhancing the system input signal-to-noise ratio and, as a result, enhancing ultimate system accuracy.

Deflection sensing devices are applied in or on a landing gear axle or other load-bearing member to enable the attachment of the gauges to the instrumentation by using techniques unsuitable for direct application to high-strength, highly heat-treated strut materials. Gauge application methods must virtually eliminate the creepage problem seen with organic adhesives in which long-term gauge strains are relieved with an attendant loss of system accuracy. Further, the application of the deflection sensing devices provides the opportunity to obtain mechanical amplification of strut deflection levels and to configure the instrumentation application geometrically to provide the rejection of deflections resulting from nonvertical loading.

The forces acting on helicopter landing gear struts are shown in Figure 3 as vertical load, side load, drag load, and scrub turn torque. These forces are individually diagrammed in Figures 4 through 7, and they illustrate the environment in which landing gear sensors must perform their load measurement.

Adaptation of landing gear deflection sensors to the axle bore by means of expandable collet members has proven to be capable of the necessary positional permanence. Care must be taken when expanding any instrumentation inside an aircraft axle so that point contact or small area contact is not used to secure the hardware. Small area or point contact mounting techniques cause high stress concentrations that structurally weaken the deflecting member. Figure 8 illustrates instrumentation of the type which will produce high stress concentration as a result of the low contact area and the resultant high unit pressure. The hoop stress produced by this type of mounting, when added to the already high stress level at which landing gear axles normally operate, produces a stress level which exceeds the allowable limits. No landing gear manufacturer will guarantee any strut using instrumentation producing stress concentrations.

Figure 9 illustrates the proper application technique for expansively mounted instrumentation elements. In this application, a relatively large contact area is used to preclude stress concentrations in the landing gear axle bore. No sharp edges are used in the design of this configuration. On occasion,

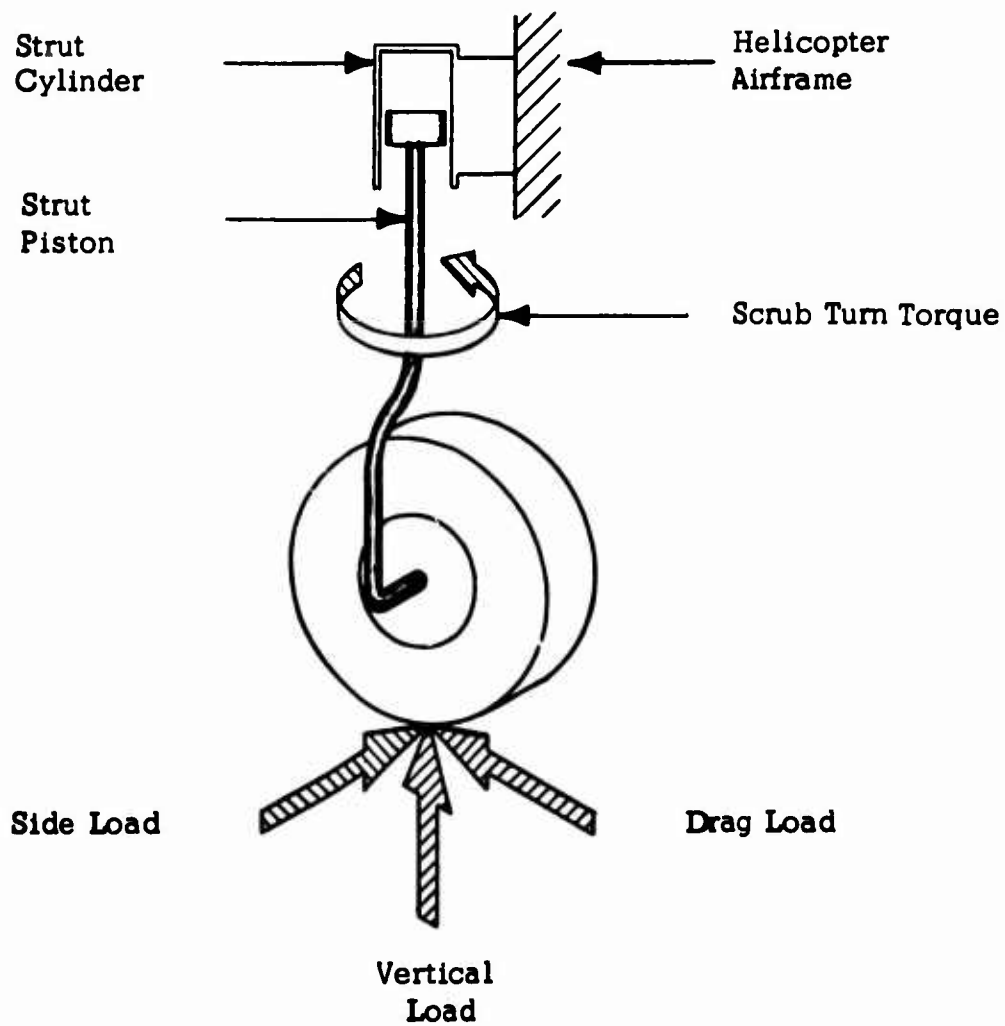

The above forces acting on the strut are diagrammed separately on the accompanying figures. The deflections shown on the figures are grossly exaggerated for the sake of clarity.

Figure 3. Forces Acting on Landing Gear Strut.

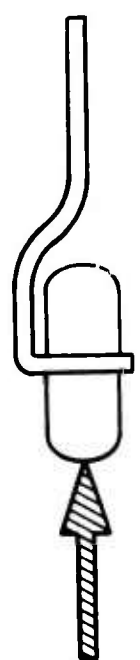

Vertical  
Load

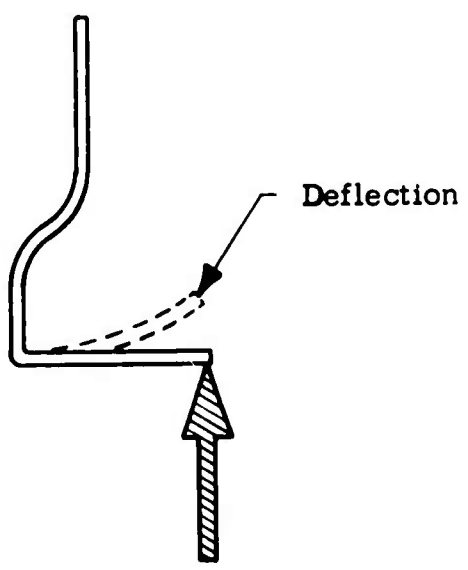

End  
Load

Figure 4. Vertical Load Force.

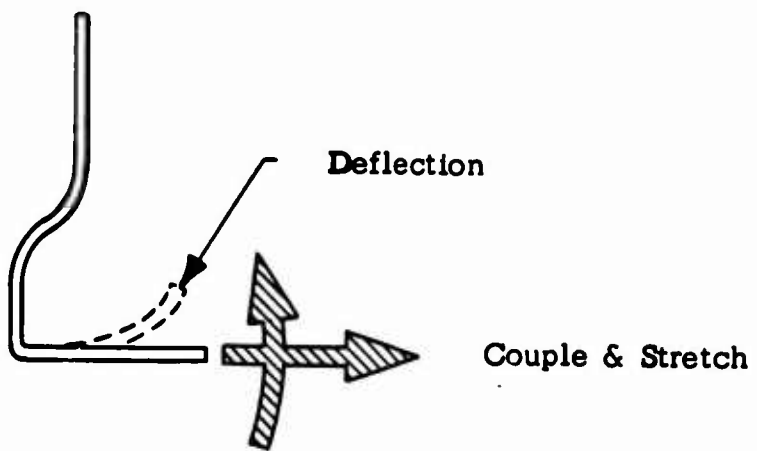
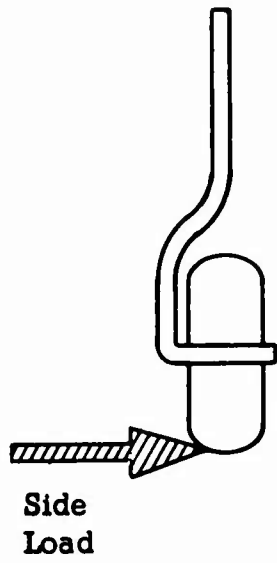

Figure 5. Side Load Force.

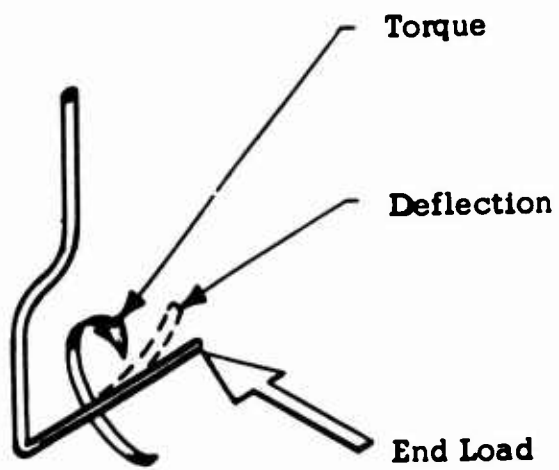
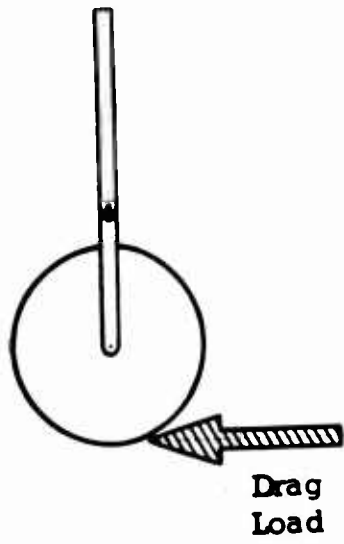
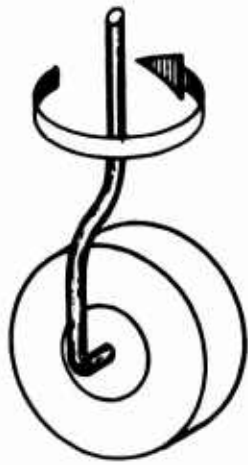

Figure 6. Drag Load Force.



Scrub  
Turn

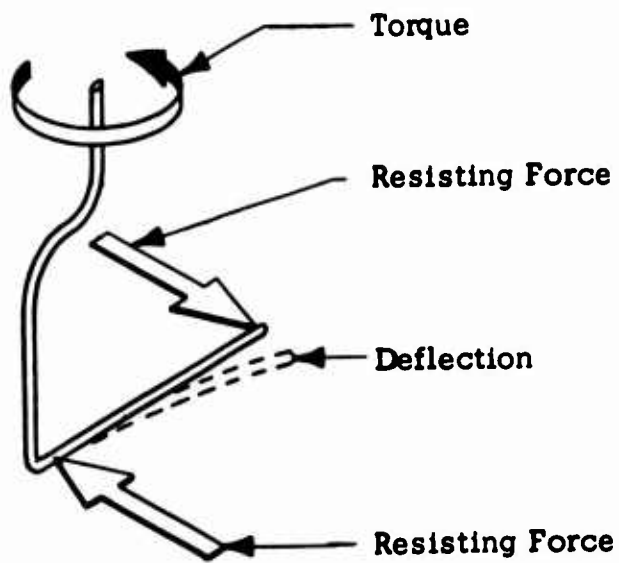

Figure 7. Scrub Turn Force.

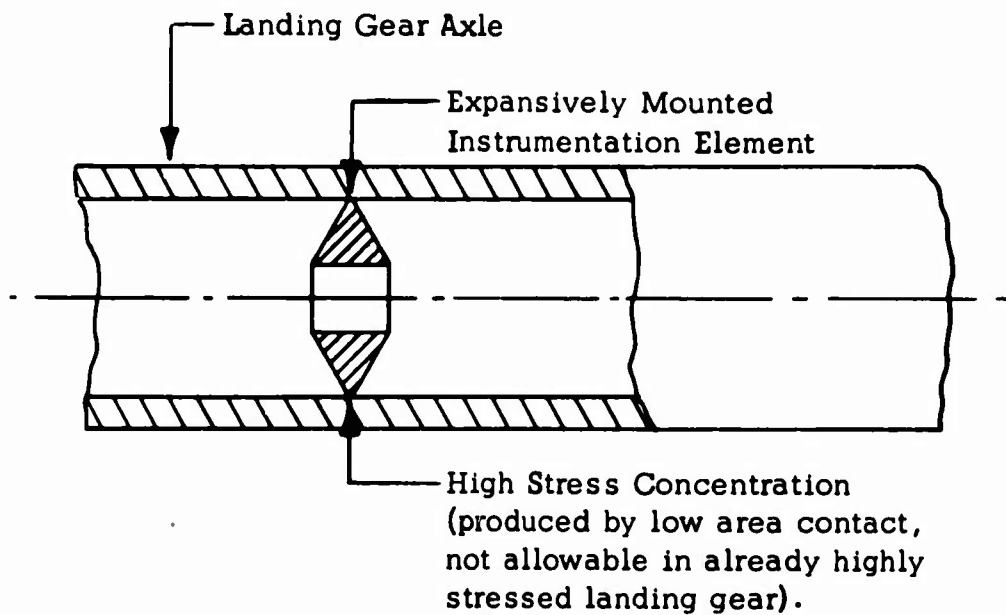

Figure 8. Instrumentation Application to Landing Gear — Improper Technique.

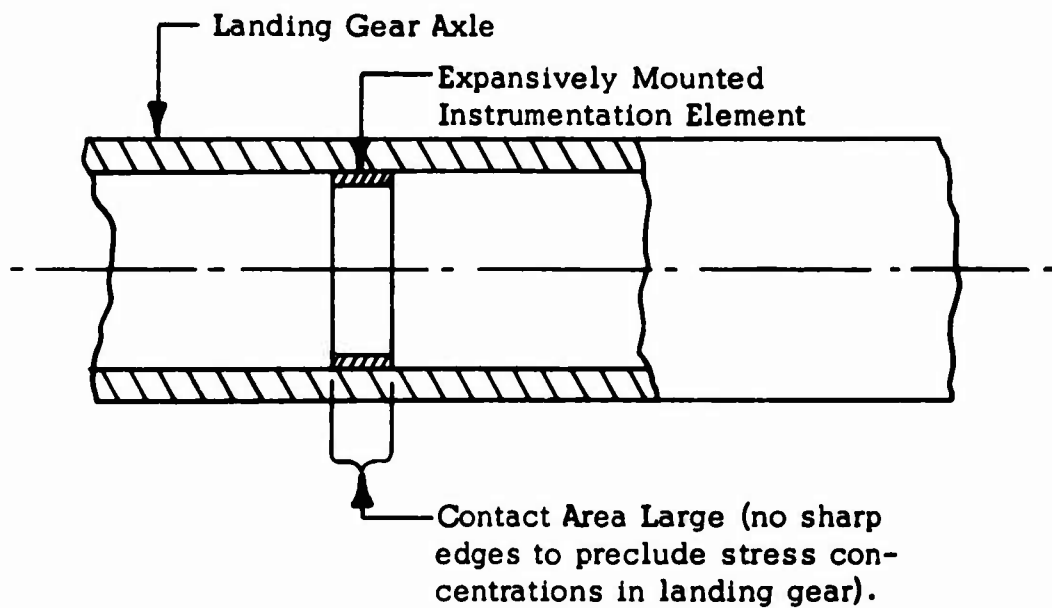

Figure 9. Instrumentation Application to Landing Gear — Proper Technique.

it has been found desirable to employ a low modulus material such as adhesive in the interface between the axle bore and the instrumentation element in a band on either side of a central band of high modulus material. This technique provides axial support for the instrumentation elements, excludes moisture and the attendant corrosion problem, and also eliminates wear of the landing gear axle by eliminating the entry of abrasive particles in the axle to instrumentation interface. Instrumentation applied to landing gear in this manner has been extensively tested in the landing gear laboratory of the Cleveland Pneumatic Tool Company in environmental and repeated drop tests. Further, operational tests of aircraft in actual use have proven the capability of this design to maintain accurate and repeatable outputs.

Design of the deflection sensing instrumentation hardware must result in components which are extremely simple in configuration. That is, an ideal design would be provided as one piece, without joints which can move with respect to one another.

In general, directly applied strain gauges will be of the conventional foil or wire gauge type in the instrumentation of landing gear structure. Attachment of the foil or wire strain gauges directly to the landing gear structure by organic adhesives is extremely difficult to perform in a manner which yields long-term stability. Unprotected by any mechanical means, the adhesive bond is subject to creepage and peel failure. Nevertheless, this instrumentation system is utilized extensively in test programs where recalibration can be accomplished daily or at greater frequency.

With pressure transducers, the problem of system inaccuracy as a result of strut friction must be recognized. In general, the landing gear oleo struts employed on helicopters are rugged structures with a common characteristic of high piston-bearing friction. This friction level is increased when operation on nonlevel terrain adds binding side and drag loads to the oleo strut.

Loads measured by instrumentation installed in or on a landing gear structure will be subject to an error which is a function of the cosine of the angle between the sensitive axis of the instrumentation and vertical. Figure 10 illustrates the load relationship for this pitch attitude error. The error in strut load measurement is plotted in Figure 11.

Figure 12 illustrates an apparent shift of center of gravity as computed by the integral weight and balance system when operating under a terrain pitch slope condition.

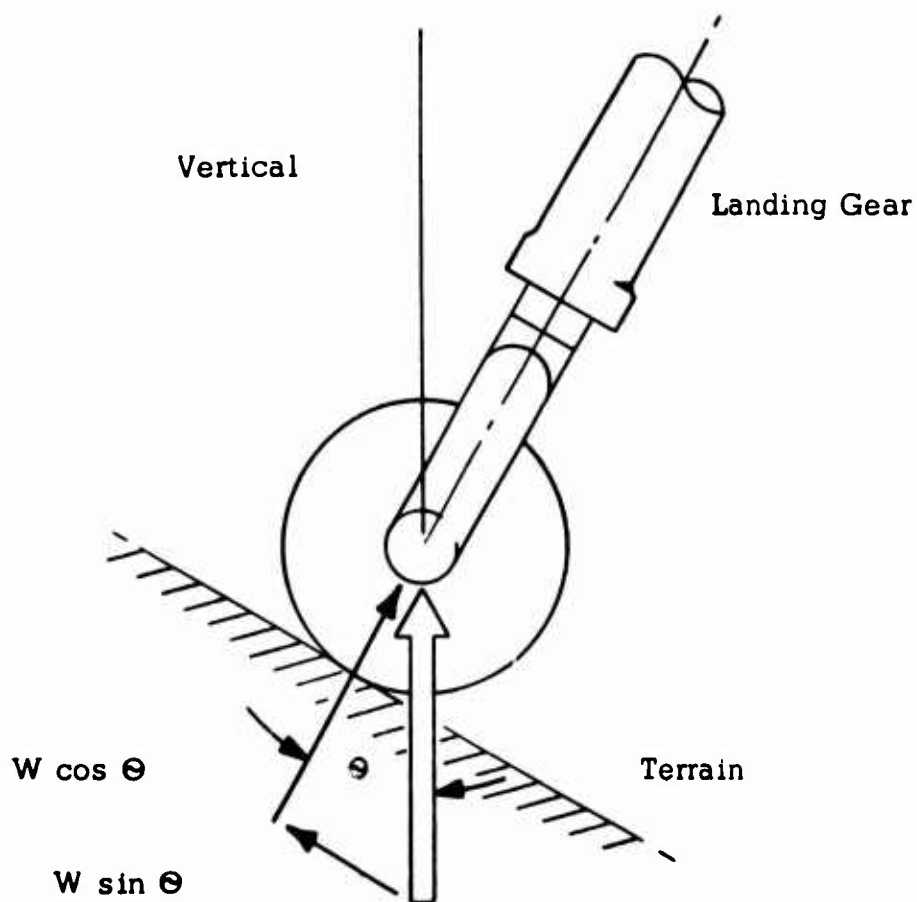

- $W$  = Total Strut Load  
 $\theta$  = Terrain Slope (pitch)  
 $W \sin \theta$  = Restraining Force as Brake or Chock  
 $W \cos \theta$  = Measured Load

Roll attitude of helicopter is stated by operational personnel to be nearly level ( $\pm 3^\circ$ ) in field use on sloped terrain. Normal pitch attitude ranges from level to  $10^\circ$  nose up or nose down.

The error in strut load measurement is plotted on Figure 11.

Figure 10. Terrain Slope Error in Strut Load Measurement.

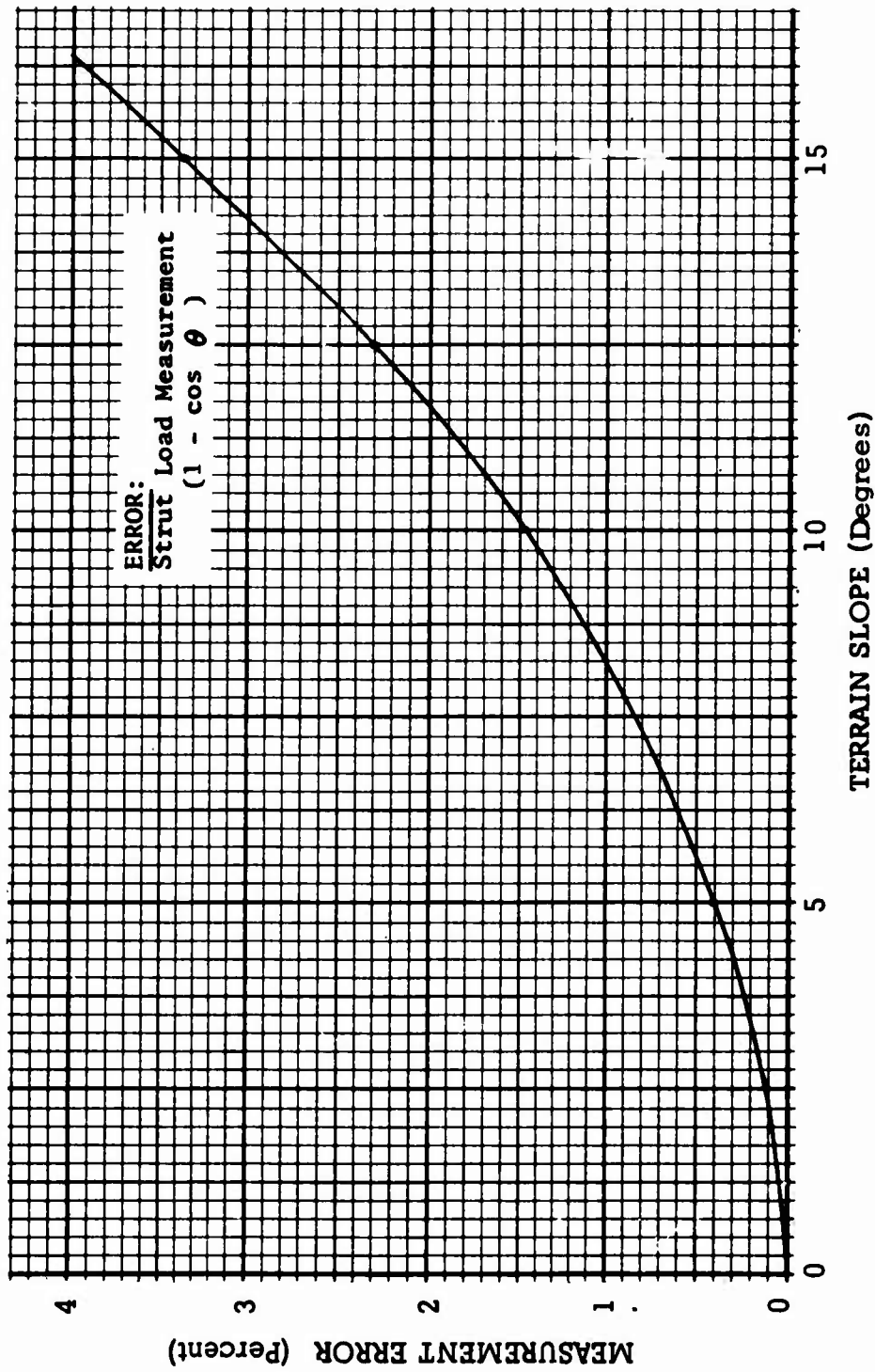

The magnitude of this error requires use of compensation for the effect in the system.

Figure 11. Strut Load Measurement Error as a Function of Pitch Attitude.

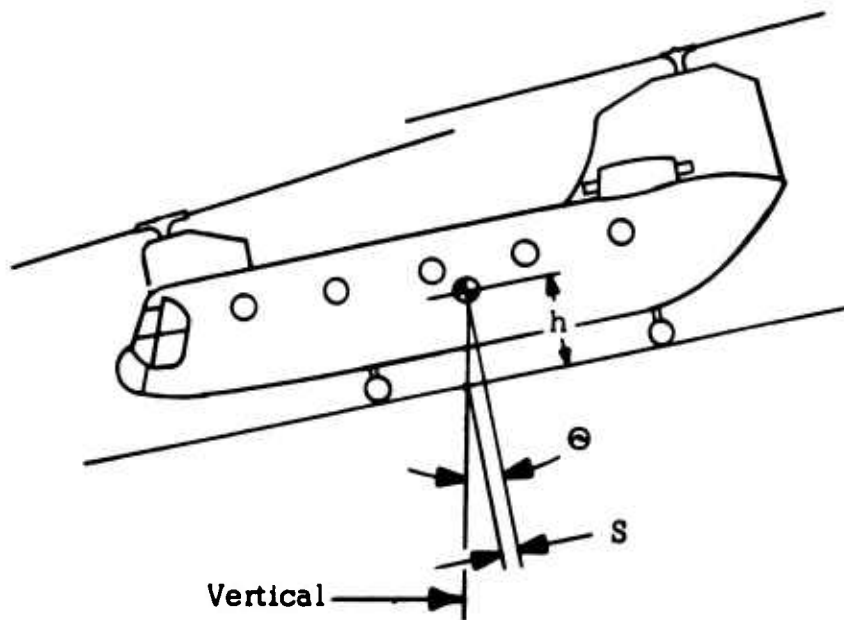

Apparent CG position

The distance on the ground that the CG moves as a result of the elevation  $h$  of the CG and the angle  $\theta$  is

$$S = h \tan \theta \cong h \theta$$

Figure 12. Terrain Slope Error in Center of Gravity Readout.

### CALIBRATION FUNCTION

The calibration section of an integral weight and balance system must provide standardization of strut load sensor signal scale factor (electrical output versus mechanical strut load input). As mentioned previously, this calibration function can be provided either at the landing gear strut instrumentation location or in a common calibration area.

### COMPUTER

The primary functions of the computer in the integral weight and balance system applied to Army cargo helicopters are:

- (a) Summation of the landing gear strut load sensor signals to provide a gross weight analog voltage output for display.
- (b) Summation of the landing gear strut moment signals in the computation of center of gravity.

The secondary functions performed by the integral weight and balance system computer are:

- (a) Correction of gross weight and center of gravity computation with respect to measured helicopter pitch attitude to a reading corresponding to that which would be obtained with the helicopter in a level or nominal attitude.
- (b) Self-check of the system to the extent deemed desirable on the basis of a trade-off between complexity and reliability.

The mechanization of the integral weight and balance system can take the following forms.

#### Manual Servo Computation

The manual servo system for computation is relatively light, simple, and low in power requirements, deriving its motive power for the display and computation from the operator. A major drawback in the use of the manually operated servo computer is the time required in manually driving the drum counter display for gross weight to the desired reading with respect to a null indicating meter and then repeating the operation for the center of gravity computation.

### Electromechanical Servo Computation

The electromechanical servo system is essentially similar to the manual servo type, with the exception that the motive power in this case is provided by a motor. The electromechanical servo system can provide a display of gross weight and center of gravity position which is constantly current and available for use at any instant.

A variation of the conventional dual servo computation system can be a hybrid system in which the gross weight servo not only drives its follow-up potentiometer and drum counter display but also drives a second potentiometer. The shaft position of the second potentiometer provides an electrical gross weight function employed in the computation of center of gravity, resulting in an electrical analog of center of gravity which is displayed on a meter mechanism.

### Digital Computation

The digital computer for an integral weight and balance system provides the computation of gross weight and center of gravity on an instantaneous basis without the use of any electromechanical parts. The complexity of the digital system in the number of parts employed causes the computer package to be somewhat larger and heavier and, in general, more expensive than the electromechanical servo computer mechanization.

### Electronic Analog Computation

The advent of small, reliable analog multiplier components will enable the elimination of the servo system from the computation mechanization of an integral weight and balance system.

### DISPLAY

Display of gross weight and center of gravity information can be implemented with a wide variety of hardware. Most commonly, this information is provided on drum counter displays. Other possible indicator configurations include hybrid drum counter and meter mechanism indicators, or even a pictorial display which, using cross pointers, would give gross weight and center of gravity condition at a glance with respect to pictorially presented limits.

The manual and electromechanical servo computers normally drive drum counter type digital displays or hybrid counter and meter mechanism displays. The digital output computer is used with magnetically actuated digit display

wheels, segmental numerical display modules, or other standard digital displays. The electronic analog computer could drive the cross-pointer display mentioned above.

### PITCH SENSOR

A pitch sensor mounted on the helicopter provides an electrical pitch angle analog signal to the computer package which is used in the compensation of the computed gross weight and center of gravity for the error induced by pitch attitude.

Pitch angle sensors can be implemented in a number of configurations involving sensing of the position of a pendulous mass. The commonly employed pickoff devices used in the pitch sensors are:

- (a) Potentiometer pickoffs
- (b) Electromagnetic pickoffs
- (c) Strain gauges

Strain gauge and electromagnetic pickoffs, such as the LVDT or reluctance pickoff, have the important advantage of no contacting surfaces to cause wear under the high vibration levels which are normal aboard a helicopter.

### CONTROL

Application of system power, the control of system test, and other functions, as necessary, are performed in the control section of the system. The equipment for these control functions can be packaged in a separate unit or can be incorporated in the computer or indicator packages, as desired. Further, the functions can be divided in their location, with those concerned with the normal operation and control of the system located near the display, and those used less frequently in test located on the computer package. Typical integral weight and balance controls are as follows:

- (a) Power switch
- (b) Readout command switch
- (c) Test switch
- (d) Sensor signal control switches
- (e) Lift compensation potentiometer(s)
- (f) Annunciator lights

The system power switch is generally a two-position type enabling the system to remain energized, as required.

The readout command switch may or may not be used, depending upon the particular system configuration. Certain systems are energized for reading gross weight and center of gravity on a continuous basis, while others are updated from a previous reading only by the engagement of a momentary readout command switch.

The system test switch is generally of the momentary type, causing the system to perform a preselected computation of gross weight and center of gravity. Readout of system test results is accomplished either by reference to the gross weight and center of gravity displays or, in certain instances, by reference to a light or lights annunciating the system condition.

It is sometimes desirable to provide the capability to control the input of the landing gear strut load sensor signals to the calibration and computer section of the integral weight and balance system. In this manner, individual load sensor outputs can be read and used in the operational test procedures devised for the given system.

Additional system controls, in the system to be recommended later in this document for application to Army helicopters, are potentiometers located on the control package which enable the compensation of rotor lift during gross weight and center of gravity measurements performed with the rotor(s) in operation.

#### SYSTEM CONFIGURATION VARIATIONS

The general block diagram for an integral weight and balance system was shown previously in Figure 2. Possible system variations are shown in this section.

In each case, the signals from the landing gear load sensing instrumentation are calibrated (standardized) and summed into a single weight summing amplifier and a single center of gravity moment summing amplifier.

In the system diagram shown in Figure 13, the manual servo integral weight and balance system, and the system diagram shown in Figure 14, the electromechanical servo integral weight and balance system, the outputs of the gross weight and center of gravity moment summing amplifiers are indicated numerically on drum counter displays. In both systems, the gross weight and center of gravity analog voltages are converted to shaft position analogs derived by achieving a null balance condition with the servo follow-up potentiometer and the analog voltage involved. Display of gross weight and center of gravity in these systems results from a mechanical interconnection of the drum counter readouts with the follow-up potentiometer, thus utilizing the shaft position analog.

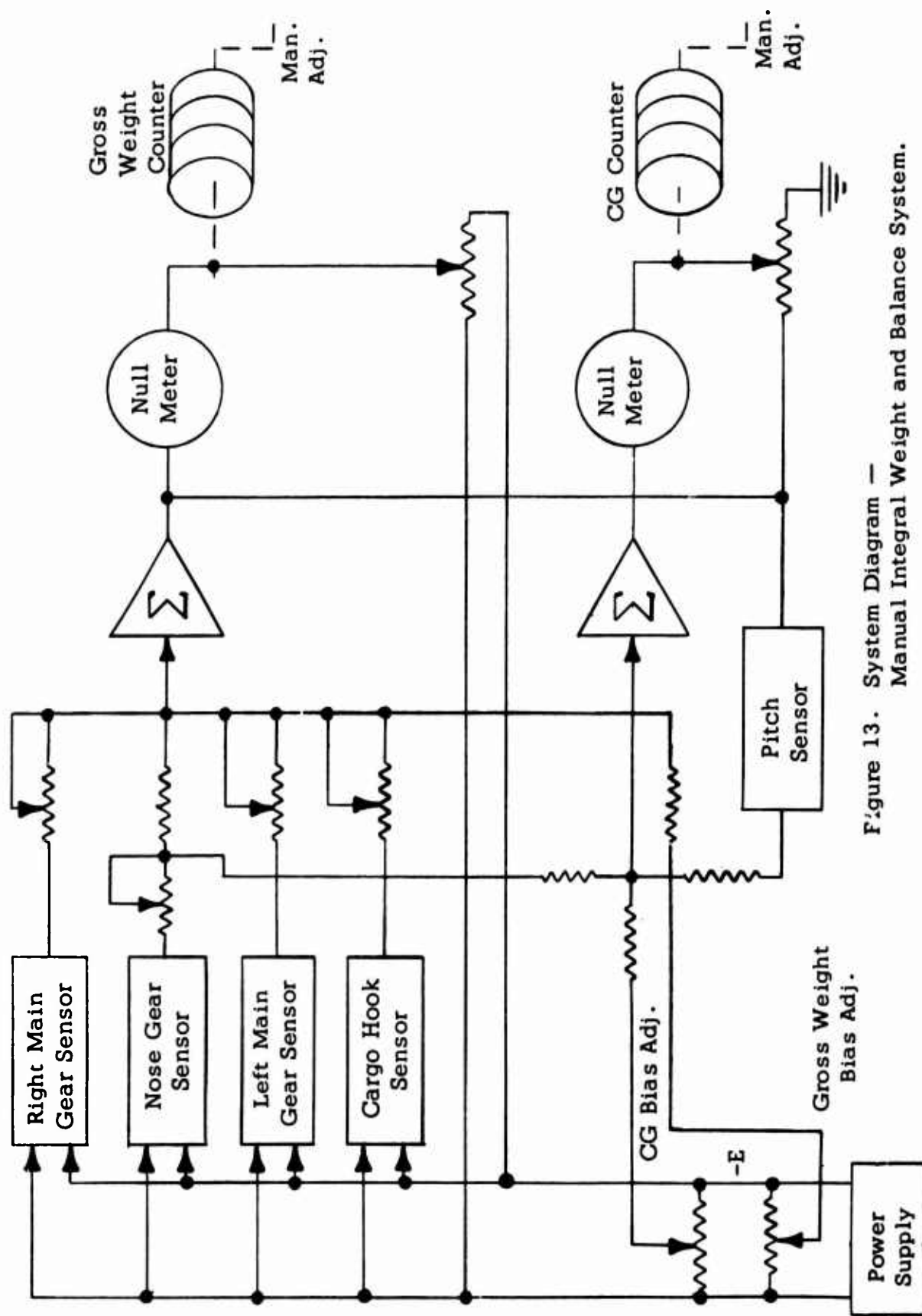

Figure 13. System Diagram — Manual Integral Weight and Balance System.

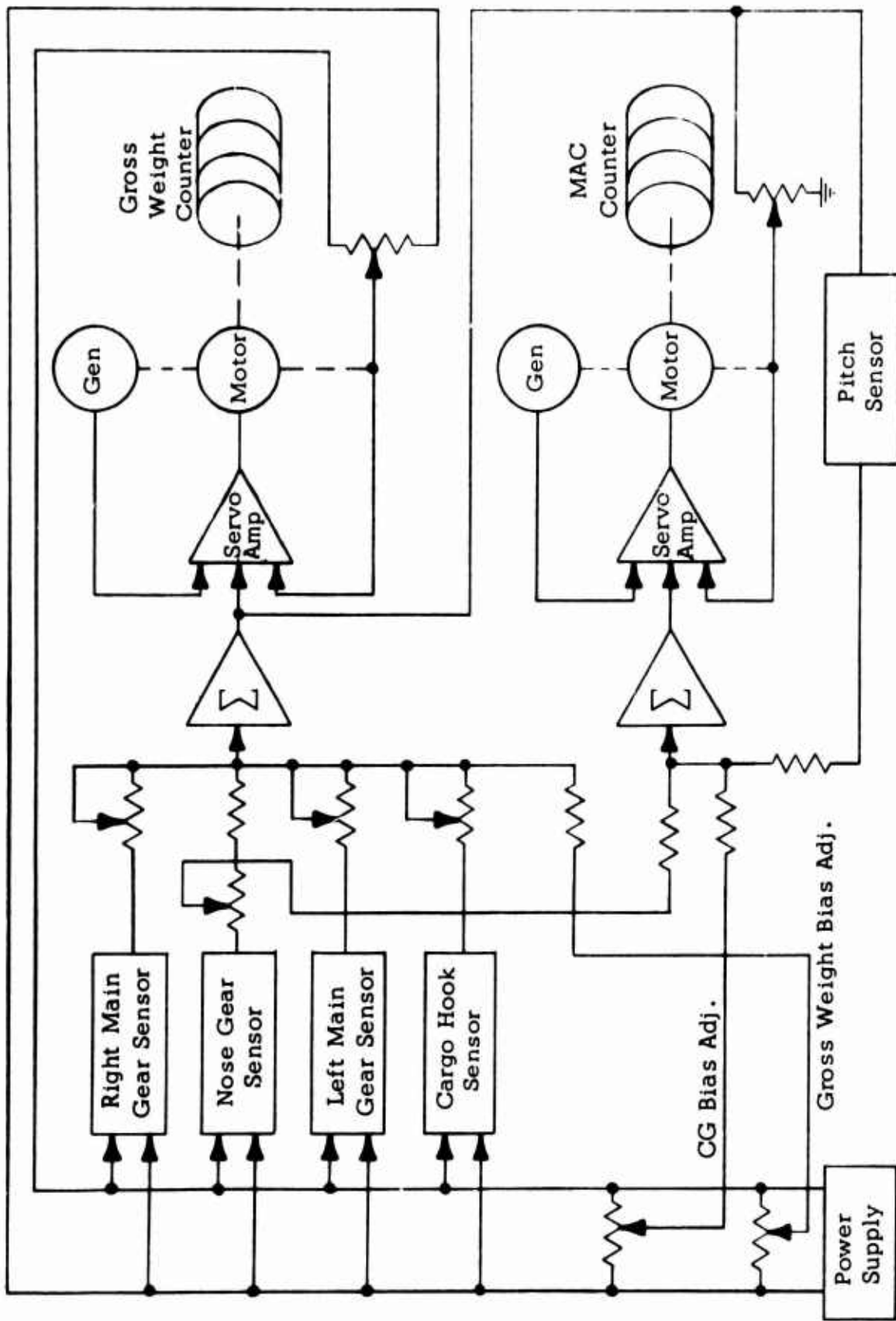

Figure 14. System Diagram — Electromechanical Servo Integral Weight and Balance System, Dual Servo Diagram.

The electromechanical servo integral weight and balance system display is self-contained, as shown in Figure 15. The manual servo display would be identical to that in Figure 15 with the addition of hand cranks capable of driving the gross weight and center of gravity mechanisms.

The hybrid electromechanical servo drum counter and meter mechanism display system shown in Figure 16 employs a unique computational scheme. The gross weight servo, in addition to its follow-up potentiometer and drum counter, drives a second potentiometer whose signal is used in the computation of center of gravity. The display used with this system is shown in Figure 17. The obvious simplicity of this system is evident in the elimination of the center of gravity servo.

Figure 18 illustrates a pictorial indicator which presents both quantitative and qualitative information on gross weight and center of gravity. In this display, two rectilinearly actuated meter mechanism pointers are disposed at 90° to each other, and each is referenced to scales graduated in units of gross weight or center of gravity, as necessary. Additionally, the background behind the cross pointers is marked with the center of gravity versus gross weight envelope for the particular helicopter involved. Thus, the user, by referring to the intersection of the pointers, is provided an immediate qualitative readout of his gross weight and center of gravity condition with regard to the allowable envelope. If the intersection should approach either the forward or aft limit lines, readings of the specific values of gross weight and center of gravity can be made by reference to the corresponding scale.

Computer outputs from the integral weight and balance system, shown in Figure 19, are in a digital format. The digital signals from the computer are displayed on suitable digital readouts. Typical readout devices are electromagnetically actuated drums, projection type digits, or illuminated segmental digits. Figure 20 illustrates an indicator employing electromagnetically actuated display drums.

The use of cargo hook and winch load lifting presents the opportunity for a desirable extension of the capability of the helicopter integral weight and balance system. That is, the system can be made to read out the load borne by the cargo hook or high-capacity winch when the helicopter is in the hover or flight mode. This is entirely feasible by instrumenting the hook or winch and displaying its signal output or those of the landing gear instrumentation as controlled by manual switching or a landing gear oleo compression switch. In this manner, when the helicopter is on the ground and the hook or winch load is zero, the load on the landing gear will be displayed as gross weight and the center of gravity will be computed and

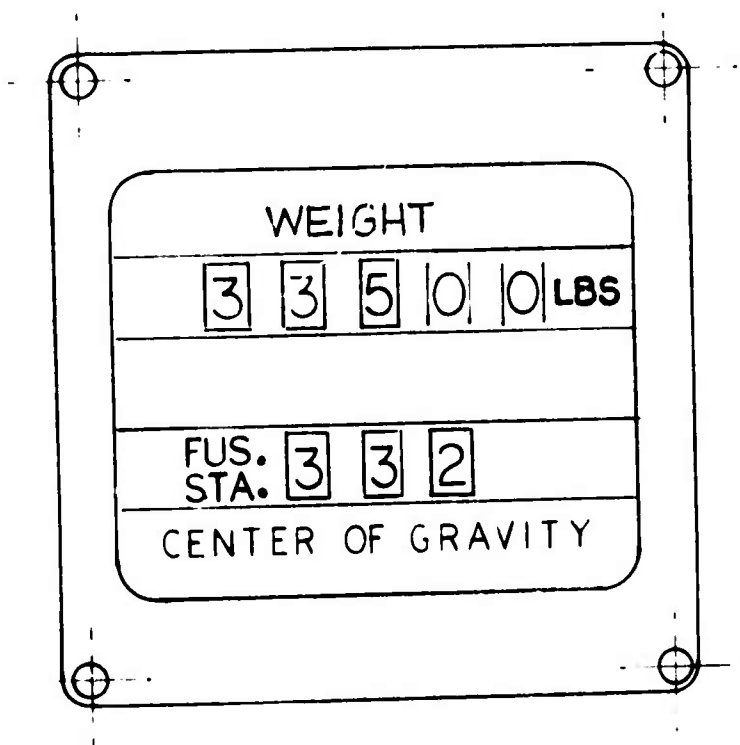

Figure 15. Weight and Center of Gravity Indicator  
— Servo Display.

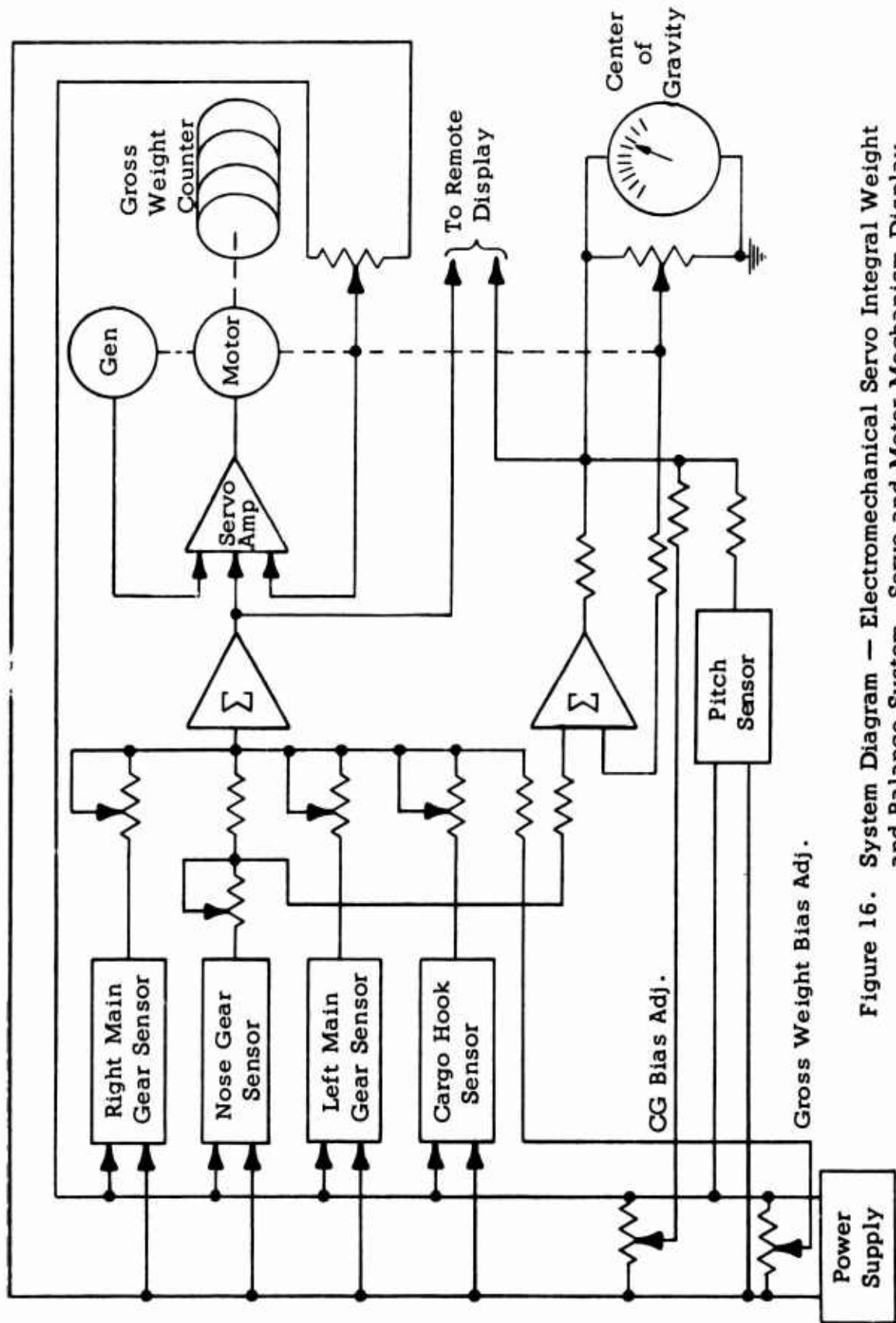

Figure 16. System Diagram — Electromechanical Servo Integral Weight and Balance System, Servo and Meter Mechanism Display.

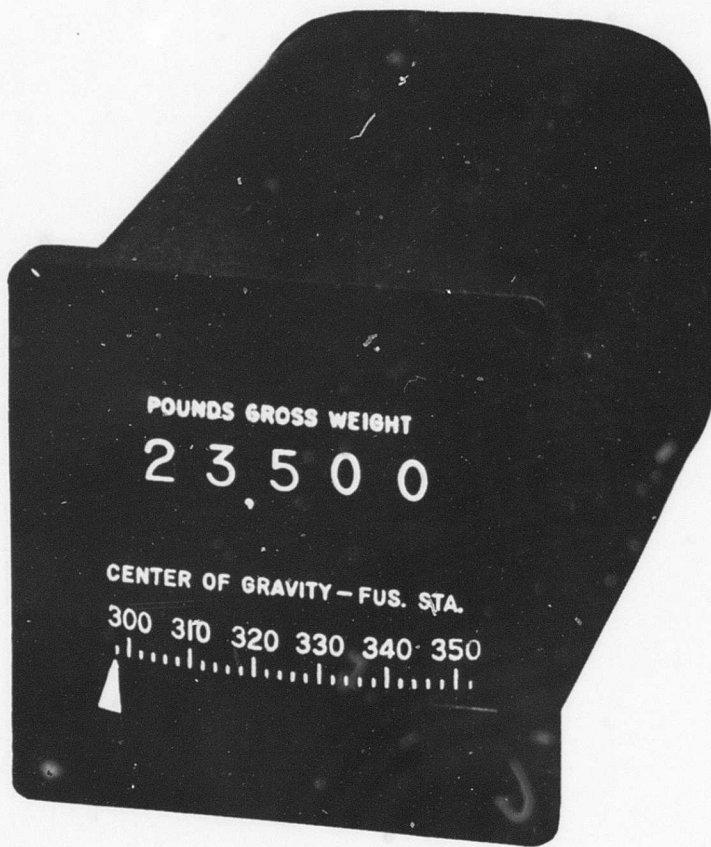

Figure 17. Weight and Center of Gravity Indicator — Servo and Meter Mechanism Display.

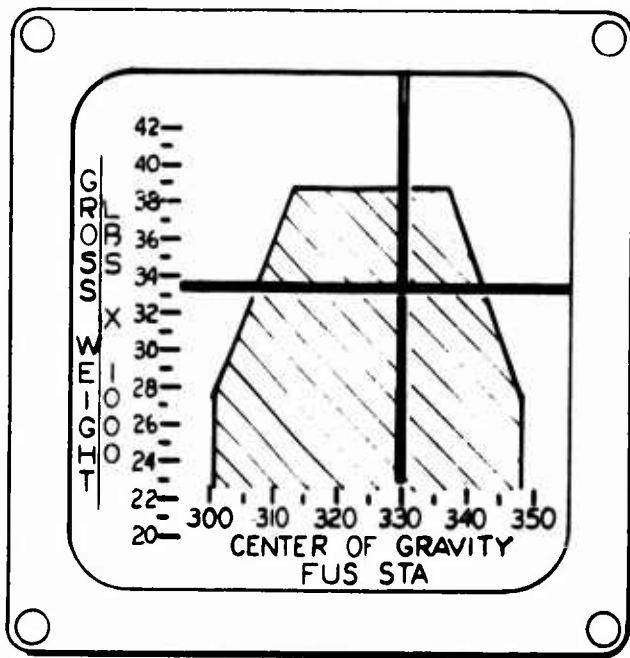

Figure 18. Weight and Center of Gravity Indicator - Dual Meter Mechanism Display.

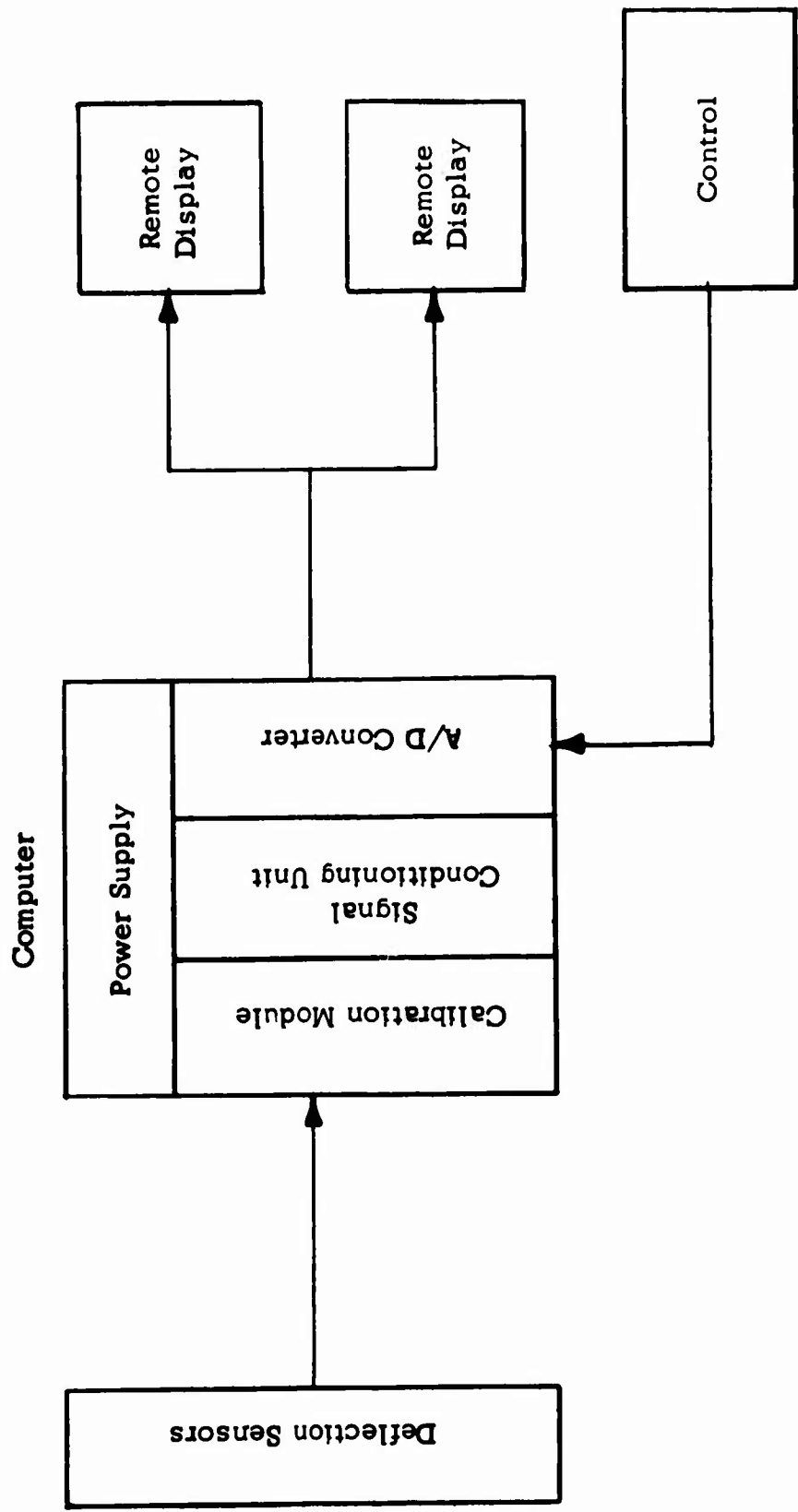

Figure 19. Block Diagram — Solid State Digital Weight and Balance System.

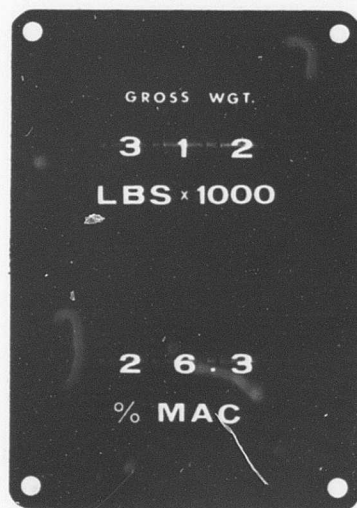

Figure 20. Weight and Balance Remote Indicator (shown actual size).

displayed. The required pitch attitude error corrections can be applied in both the gross weight and the center of gravity computations. When the helicopter lifts off the ground (unloading the landing gear struts and actuating the oleo switch), the load lifted by the hook or winch is indicated on the weight display without pitch attitude correction applied.

Center of gravity cannot be computed under this hover or flight mode condition because distribution of the load other than that on the hook is not measured. This does not present a problem though, because the center of gravity of the helicopter (measured while on the ground) cannot be adversely affected by the addition of loads through the nominal center of gravity location of the cargo hook or high-capacity winch. As previously stated, winches of low capacity mounted off the nominal center of gravity location do not provide major center of gravity shifts. After the total gross weight is lifted, that of the helicopter and its cargo hook supported load is obtained by manually adding the gross weight reading obtained on the ground and the cargo hook load readout.

Multipoint hoist systems for the CH-54 and the heavy lift helicopter enable the lifting and transporting of loads in a manner which provides greater restraint than that with single cable systems. In this way, bulky loads can be carried closer to the fuselage of the lift helicopter without danger of interference with landing gear or other helicopter structure when the load swings. The integral weight and balance system can provide readout of load on each of the multiple cables and enable the display of lift weight. Readout of individual cable tension can allow load equalization if desired. Further, if required, the center of gravity of the load could be computed while the load is completely supported by the cables.

#### SYSTEM LIMITATIONS

Certain operational conditions will not be compensated for in the systems considered in this study for these reasons:

(a) Flotation

A partial or full buoyancy effect relieves loading from the instrumented landing gear struts and makes accurate weighing with the system impossible.

(b) Moving Alightment Area

Motion of the alightment area such as that occurring on shipboard imparts acceleration to the helicopter, causing the readings derived

from landing gear instrumentation to fluctuate between over-actual and under-actual weights. It should be feasible to note maximum and minimum readings too and use an average value for gross weight. Acceleration effects can cause random variations in landing gear load distribution and, therefore, can adversely affect the accuracy of the center of gravity computation.

(c) Lateral Center of Gravity Measurement

The measurement of lateral center of gravity position serves no useful function on the CH-47 and the UH-1 helicopters. Cable tension measurement can be provided on the four-point load attachment system used on the CH-54 to enable load equalization. Determination of the center of gravity of the cable-supported load can be provided, if desired.

Personnel winches, while often displaced laterally from the allowable center of gravity envelope, are not a major contributor of lateral unbalance due to their limited lift capacity.

## RECOMMENDED SYSTEM CONFIGURATION

The following system configuration is based on the knowledge gained in the operational analysis and the experience of this contractor. The helicopter integral weight and balance system is much like that for fixed-wing aircraft, but at the same time it offers problems which are solely existent in helicopter operation.

In this section, the instrumentation technique recommended for various landing gear strut structural configurations will be described. The resultant load sensor signals are routed to the calibration/computer package for calibration and summation of strut load and moment signals. The system recommended herein has the capability of accepting landing gear strut load sensor signals from any number of struts without regard to their structural configuration or geometric relationship. The gross weight and center of gravity electrical analog signals are then fed to the display for presentation.

System commonality in components is shown in Table V. It will be noted that for the UH-1, CH-47, CH-54, heavy lift helicopter cargo version, and heavy lift helicopter personnel version, the integral weight and balance system components are identical from application to application, with the exception of the value and quantity of certain circuit elements and the load sensor adapter hardware. This hardware, naturally, must be designed for the specific structural instrumentation required.

In Figures 21 through 29, integral weight and balance systems are illustrated for the UH-1, the CH-54, and the CH-47. Each integral weight and balance system component and its location aboard each helicopter type are illustrated. Also included is a figure showing the landing gear instrumentation concept and the computation of center of gravity for each of the three helicopters. The center of gravity envelopes for each application are also provided for comparison on separate figures.

It will be noted on the illustration of the center of gravity envelope for the CH-47 that errors in gross weight which might reasonably be expected to exist in field operation with estimated weight (5% and 10% gross weight error) cause major departure from the specified center of gravity flight envelope. The use of an integral weight and balance system will provide accurate gross weight and center of gravity measurements and will assure operation of helicopters at maximum safe loads in the specified center of gravity envelope.

TABLE V  
INTEGRAL WEIGHT AND BALANCE SYSTEM COMPONENT COMMONALITY

HELICOPTER DATA			IWBS COMPONENTS					
Type	Gross Weight Range (lb.)	Landing Gear Config.	Load Sensor Adapter Hardware	Load Sensor	Pitch Sensor	Calibration/Computer Package	Control	Display
UH-1	4,500-9,500	2 Skid	Special	Std.	Std.	Std.*	Std.	Std.**
CH-47	18,000-38,500	4 Skid	Special	Std.	Std.	Std.*	Std.	Std.**
CH-54	19,000-38,000	3 Strut	Special	Std.	Std.	Std.*	Std.	Std.**
HLH (Cargo)	37,000-82,000 (Est.)	3 Strut	Special	Std.	Std.	Std.*	Std.	Std.**
HLH (Personnel)	40,000-83,000 (Est.)	3 Strut	Special	Std.	Std.	Std.*	Std.	Std.**

\* Identical package — value and quantity of some circuit elements will vary with application.

\*\* Identical package — readout range for weight and CG indications will vary with application.

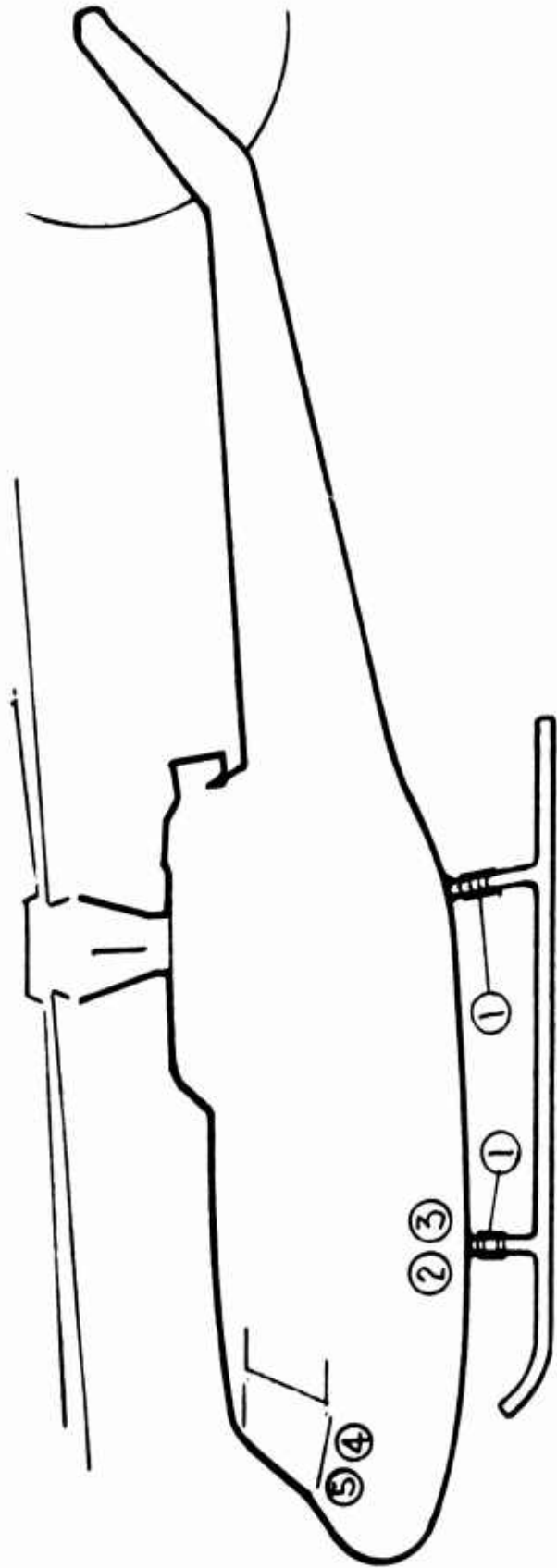

- 1. LOAD SENSORS - 4 external (on lateral tubes)
- 2. PITCH SENSOR - Standard
- 3. CALIBRATION/COMPUTER - Standard (4 inputs)
- 4. CONTROL - Standard (power and test switches, sensor control annunciator, lift offset pot)
- 5. DISPLAY - Standard (servo and meter mechanism display)

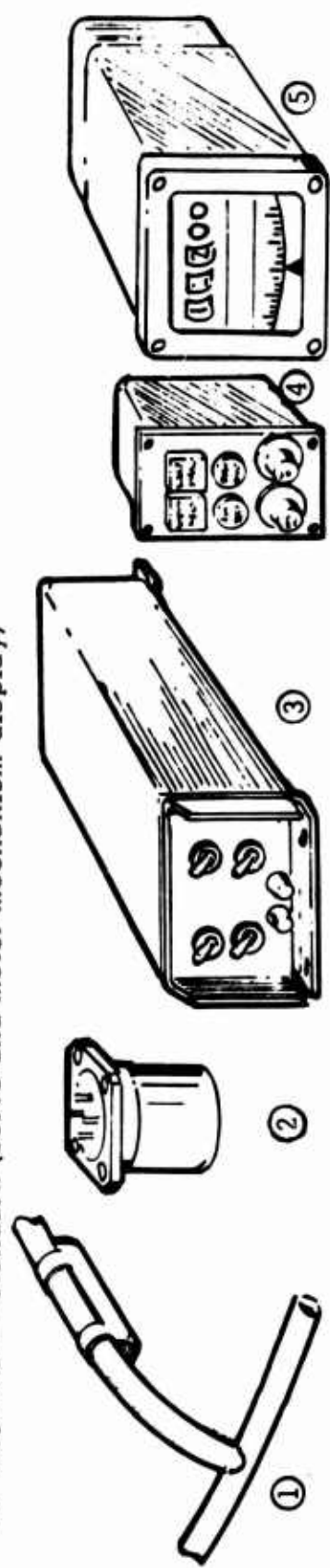
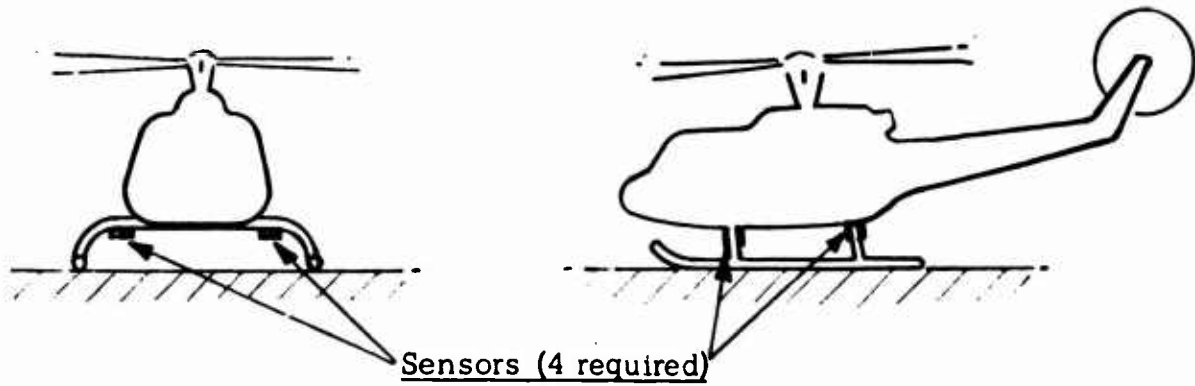
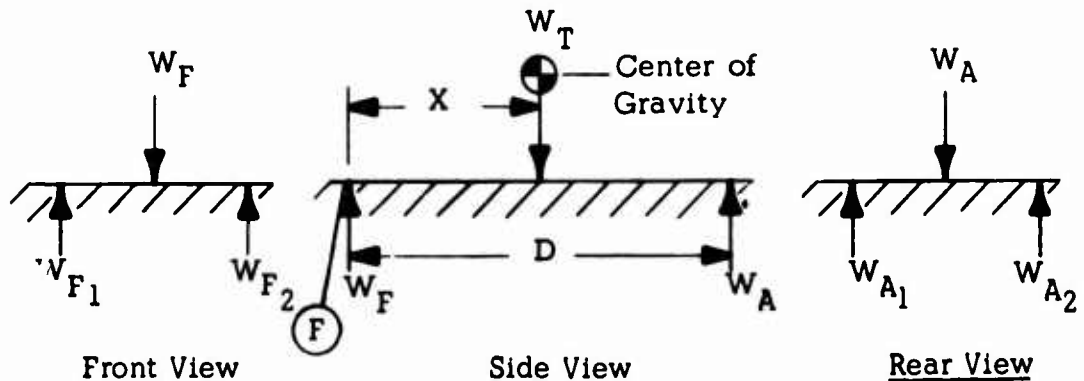

Figure 21. Integral Weight and Balance System for the UH-1.



Sensors (4 required)



Front View

Side View

Rear View

- F - Location of forward strut
- D - Distance between forward and aft struts
- X - Distance from point F to center of gravity
- $W_{F1}$  - Weight on forward starboard strut
- $W_{F2}$  - Weight on forward port strut
- $W_F$  - Weight on forward struts =  $W_{F1} + W_{F2}$
- $W_{A1}$  - Weight on aft starboard strut
- $W_{A2}$  - Weight on aft port strut
- $W_A$  - Weight on aft struts =  $W_{A1} + W_{A2}$
- $W_T$  - Total weight of aircraft + load =  $W_F + W_A$

Purpose: To determine X distance from forward strut to center of gravity

$$\sum \text{ Moments about point F} = 0 \quad DW_A - XW_T = 0$$

$$X = \frac{W_A}{W_T} D$$

Figure 22. Computation of Center of Gravity for Two-Skid Landing Gear (as on UH-1).

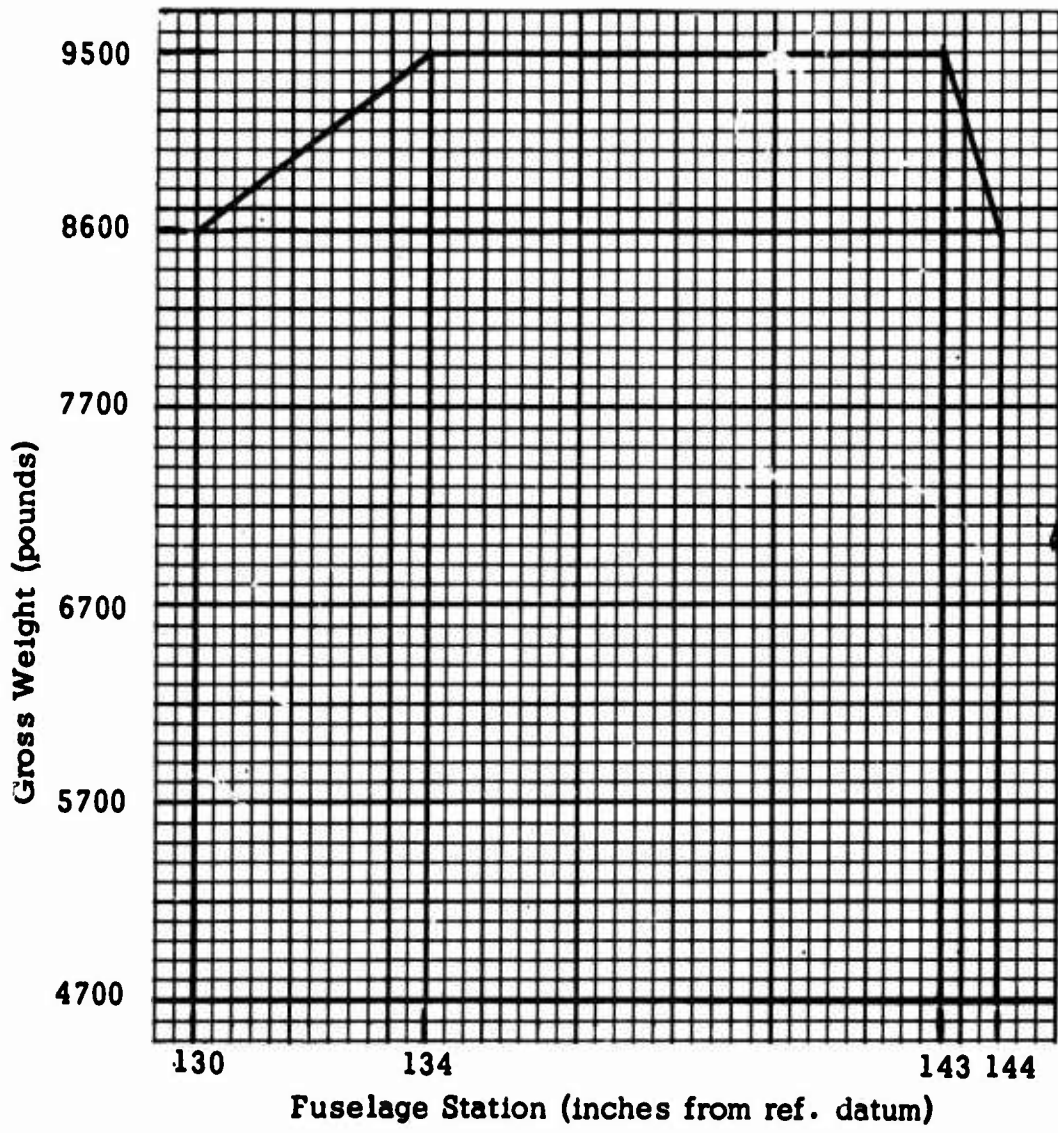
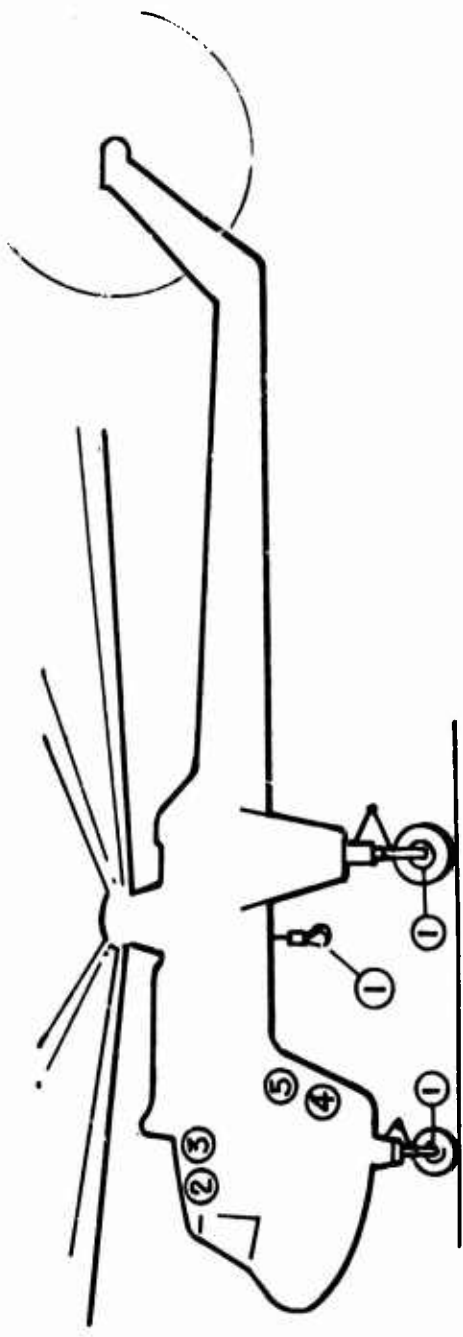

Figure 23. Center of Gravity Envelope (UH-1D).



1. LOAD SENSORS — 1 in each landing gear axle, 1 on hoist, 1 each multipoint load support cable
2. PITCH SENSOR — Standard
3. CALIBRATION/COMPUTER — Standard (4 inputs)
4. CONTROL — Standard (power and test switches, sensor control annunciator, lift offset)
5. DISPLAY — Standard (servo and meter mechanism display)

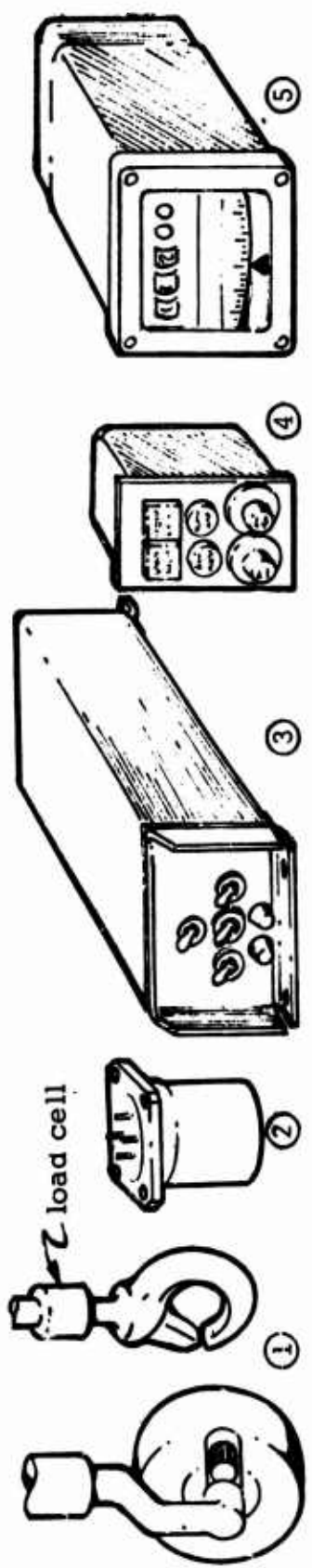
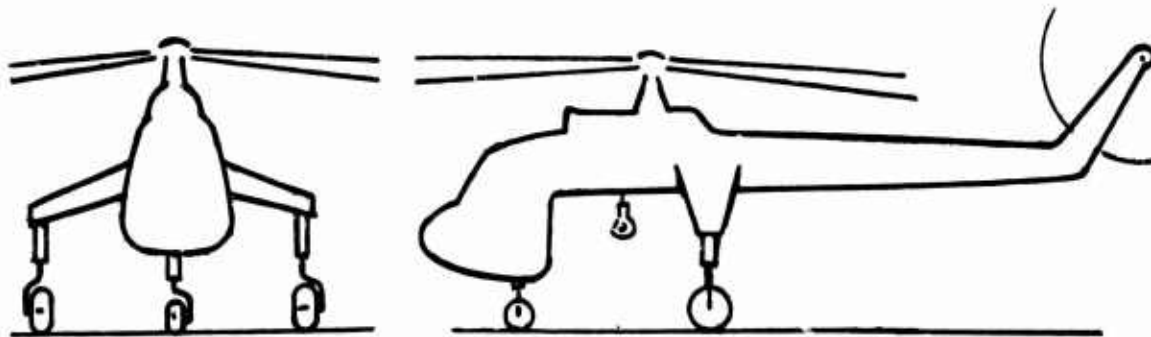
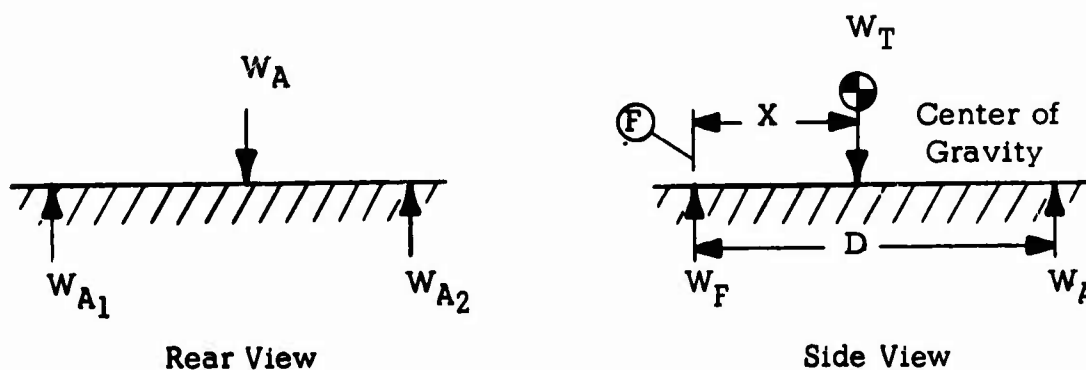

Figure 24. Integral Weight and Balance System for the CH-54.



Sensor in each axle (3 required)



- F - Location of forward axle
- D - Distance between forward and aft axles
- X - Distance from point F to center of gravity
- $W_{A1}$  - Weight on aft starboard wheel
- $W_{A2}$  - Weight on aft port wheel
- $W_A$  - Total weight on aft wheels =  $W_{A1} + W_{A2}$
- $W_F$  - Weight on forward wheel
- $W_T$  - Total weight of aircraft + load =  $W_A + W_F$

Purpose: To determine X distance from forward strut to center of gravity

Moments about point F = 0

$$D W_A - X W_T = 0$$

$$X = \frac{W_A}{W_T} D$$

Figure 25. Computation of Center of Gravity for Tricycle Landing Gear (as on CH-54).

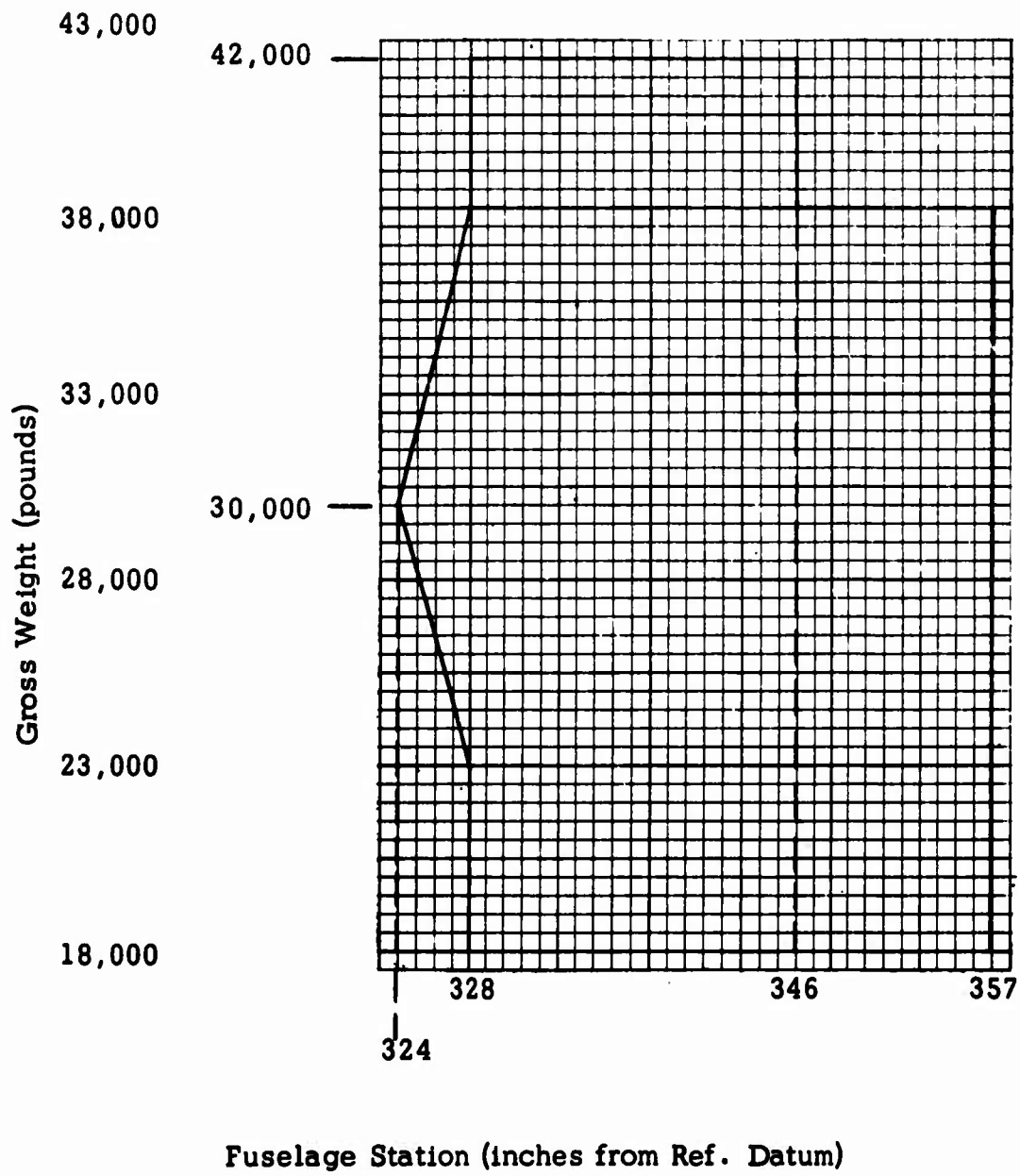
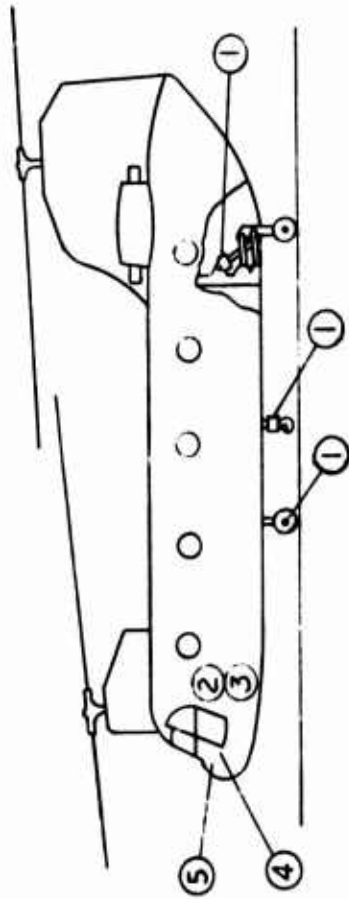

Figure 26. Center of Gravity Envelope for CH-54.



1. LOAD SENSORS — Pairs in forward strut axles, 1 on aft strut oleo cap, 1 on hoist
2. PITCH SENSOR — Standard
3. CALIBRATION/COMPUTER — Standard (7 inputs)
4. CONTROL — Standard (power and test switches, sensor control annunciator, lift offset control)
5. DISPLAY — Standard (servo and meter mechanism display)

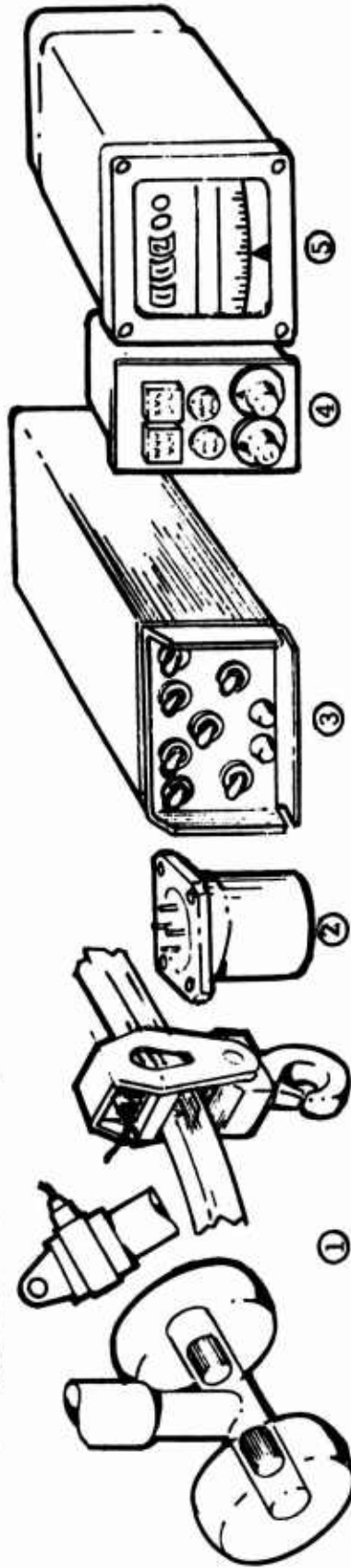
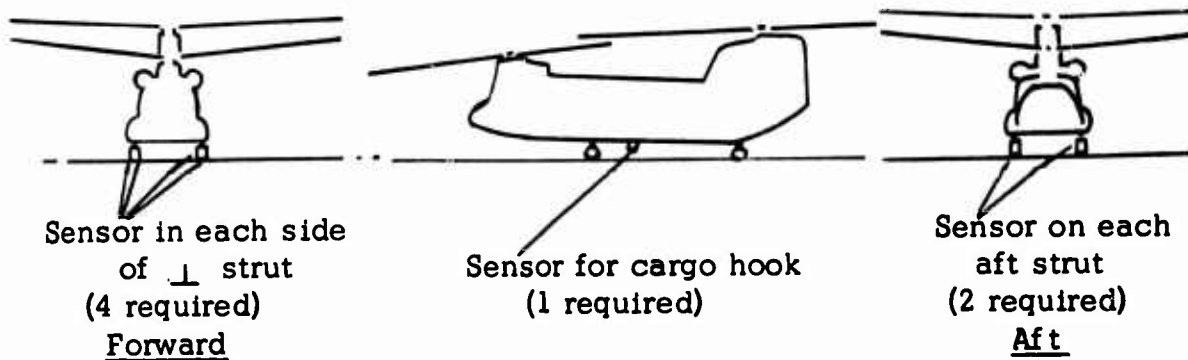
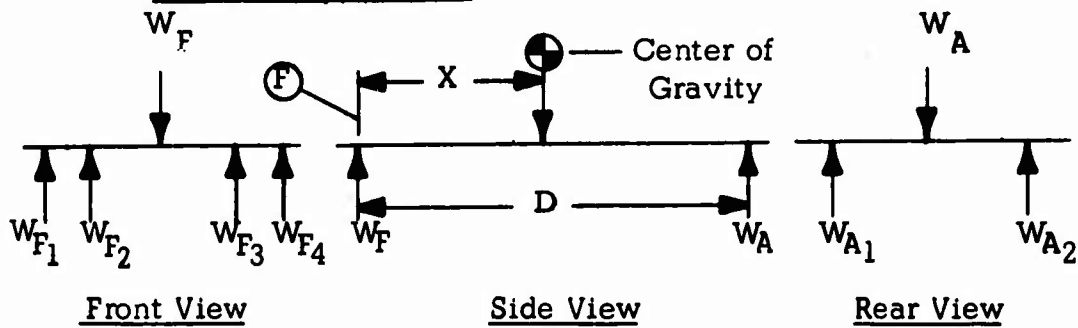

Figure 27. Integral Weight and Balance System for the CH-47.



Sensor Requirements: 7 for aircraft + cargo hook



- F - Location of forward axle
- D - Distance between forward and aft struts
- X - Distance from point F to center of gravity
- $W_{F1}$  - Weight on starboard forward outboard wheel
- $W_{F2}$  - Weight on starboard forward inboard wheel
- $W_{F3}$  - Weight on port forward inboard wheel
- $W_{F4}$  - Weight on port forward outboard wheel
- $W_F$  - Total weight on forward wheels =  $W_{F1} + W_{F2} + W_{F3} + W_{F4}$
- $W_{A1}$  - Weight on port aft wheel
- $W_{A2}$  - Weight on starboard aft wheel
- $W_A$  - Total weight on aft wheels =  $W_{A1} + W_{A2}$
- $W_T$  - Total weight of aircraft + load =  $W_A + W_F$

Purpose: To determine X distance from forward strut to center of gravity

$$\sum \text{ Moments about point F} = 0 \quad DW_A - XW_T = 0$$

$$X = \frac{W_A}{W_T} D$$

Figure 28. Computation of Center of Gravity for Quadricycle Landing Gear (as on CH-47).

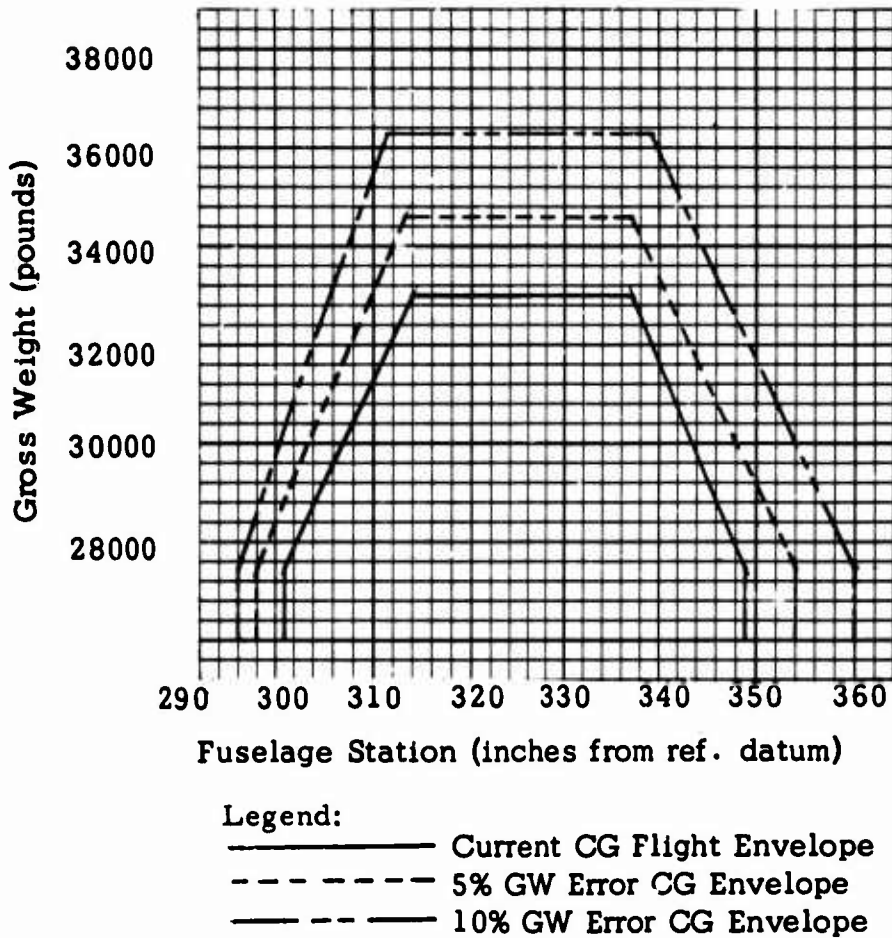

The current flight envelope for center of gravity position can be exceeded when manual computation is made with the gross weight value in error by the percentages shown. Operation outside the prescribed flight envelope can cause decreased operational life of the helicopter as a result of the increase in structural fatigue.

Obviously, an integral weight and balance system providing accurate gross weight and center of gravity measurements can be used to assure operation of helicopters at maximum safe loads in the specified center of gravity envelope, providing optimum flight trim and therefore maximum flight range or duration.

The above plot shows computations using the CH-47A center of gravity envelope as an example.

Figure 29. Effect of Error in Gross Weight on Computation of Center of Gravity Location.

A major requirement for an integral weight and balance system suitable for Army helicopter operations is the capability to provide accurate gross weight and center of gravity readings under the conditions encountered with the rotor(s) running or at rest. The system recommended herein possesses this capability in that the gross weight and center of gravity of the helicopter can be determined accurately with the rotor(s) stopped and that these values can be used for reference in compensating for this appreciable error. (The C-47A at 230 RPM and minimum blade collective pitch of  $+3^\circ$  produces a lift on the order of 20% to 30% of helicopter gross weight. Obviously, a practical means of compensating for this effect must be provided.)

The environment to which the helicopter integral weight and balance system equipment is subjected in operation imposes important requirements which must be accommodated in the system and component design. For example, the existing low-frequency vibration levels must be taken into account in the design of the calibration/computer and display packages, both in their structural capabilities and in the signal response characteristics provided to minimize display fluctuation during rotor operation. The salt water or mud immersion of the landing gear struts must also be accommodated.

The recommended system configuration has been previously shown in Figure 16. As stated earlier and shown on the schematic, this system uses single weight and center of gravity summing amplifiers which accept signals from any number of landing gear struts without regard to the structural configuration of the struts or to their geometric relationship. This system utilizes the servo-driven counter for gross weight display and the meter mechanism display for center of gravity. Obvious advantages are obtained in the use of this hybrid system configuration; namely, the elimination of the center of gravity servo system and the attendant reduction in system complexity. Logically, the reliability of the system is enhanced by the elimination of the center of gravity servo components by substitution of the meter mechanism display for center of gravity. Further, cost of such a system is somewhat reduced. Referring to Figure 17, the display package, the suitability of the meter mechanism display for center of gravity is apparent. Graduations on the scale, shown in this instance for the CH-47 Chinook, are in terms of inches (fuselage station). Graduations are provided in 2-inch increments, and, without question, an adequate readout resolution is provided.

Details will also be provided in this section on the pitch sensor used in the compensation of the gross weight and the center of gravity computation with regard to pitch angle of the helicopter and on the control and cargo hook instrumentation.

## LANDING GEAR STRUT INSTRUMENTATION

The various landing gear structural configurations described in this section are all instrumented by the deflection sensing device developed by National Water Lift Company.

The deflection sensor (Figure 30) is an alloy steel cantilever beam instrumented on two opposite sides, parallel to its longitudinal axis, with semiconductor type strain gauges and the necessary compensating elements, providing stability of null and scale factor with temperature variation. This device has been produced in quantity and has proven to be reliable in its application to the Air Force C-130 integral weight and balance system. High signal levels are available (30 mv/0.10-in. deflection) and provide a high signal-to-noise ratio input to the calibration/computer package. System accuracy is thereby improved as a result of the signal levels available.

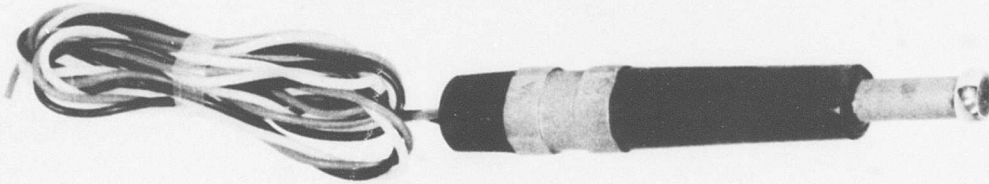

Figure 30. Deflection Sensor Bar.

The sensing technique recommended for use in the integral weight and balance system described herein provides sensitivity solely to applied vertical shear load. The electrical output of the deflection sensor assembly in an axle is a function of its geometry, the sectional properties of the axle, and the applied vertical shear load. Other load inputs to the strut, as previously shown in Figures 3 through 7, resolve into orthogonally disposed components and couples to which the recommended system is insensitive.

The applied vertical shear loading is measured by the deflection sensor assembly as shear displacement and as the vertical component of the bending displacement. It should be noted that the relative magnitude of the shear deflection is small when compared to the vertical component of the bending displacement. The recommended system sensor signal output is high, since the sum of signals resulting from both deflections is used. Those systems measuring shear deflection alone are penalized in their low output

signal level by dependence upon the minor shear deflection.

One of the most common landing gear strut structural configurations is the "T" type shown in Figures 31 and 32. Instrumentation of this type of strut requires the measurement of the deflection of both axles. This is necessitated by the lack of pivoting capability to enable equalization of load distribution on the two axles. That is, in the extreme case with one wheel over a hole, the other wheel can support the full strut load.

The equipment shown in Figure 33 typifies the instrumentation to be employed within an axle bore. Two permanent instrumentation elements are shown which are capable of expansive mounting within the axle bore. These devices are positioned longitudinally, axially, and rotationally within the bore by means of a simple locating tool for each device.

The sensor and its mounting device are located within the permanently mounted adapter in the axle and are screw-adjusted and locked to provide the proper contact between the tungsten carbide spherical tip on the deflection sensor and the tungsten carbide surface on the preload anvil. The permanence of the instrumentation mounting thus achieved has been thoroughly proven in landing gear laboratory drop testing and in actual aircraft installation. Figure 34 depicts schematically the installation of both deflection sensor assemblies within a "T" type axle strut.

A single-wheel "L" configuration cantilever landing gear strut is shown in Figures 35 and 36. Figure 37 illustrates the installation of landing gear axle instrumentation hardware similar to that shown in Figure 33 in the "L" type cantilever strut.

Figure 38 illustrates a single-wheel cantilever strut capable of 360° swiveling while supported by a pair of drag arms and a diagonally mounted oleo strut. An obvious problem exists in the instrumentation of an axle with full swiveling capability; that is, it is highly undesirable to carry deflection sensor signals through slip-ring arrangements due to their tendency to induce a high noise content in the signal. With this problem in mind, another solution to the instrumentation is desirable and is found in the replacement of the top cap of the oleo strut with an assembly configured as shown in Figure 39. This instrumentation method provides a diaphragm that deflects under landing gear loads; it also provides measurement of this displacement by the deflection sensor shown. It will be noted that, as the landing gear loads increase, the sensor preload deflection is decreased, protecting the deflection sensor from overload conditions. This enables the use of the full deflection sensor range for instrumentation rather than necessitating a large over-deflection safety factor.

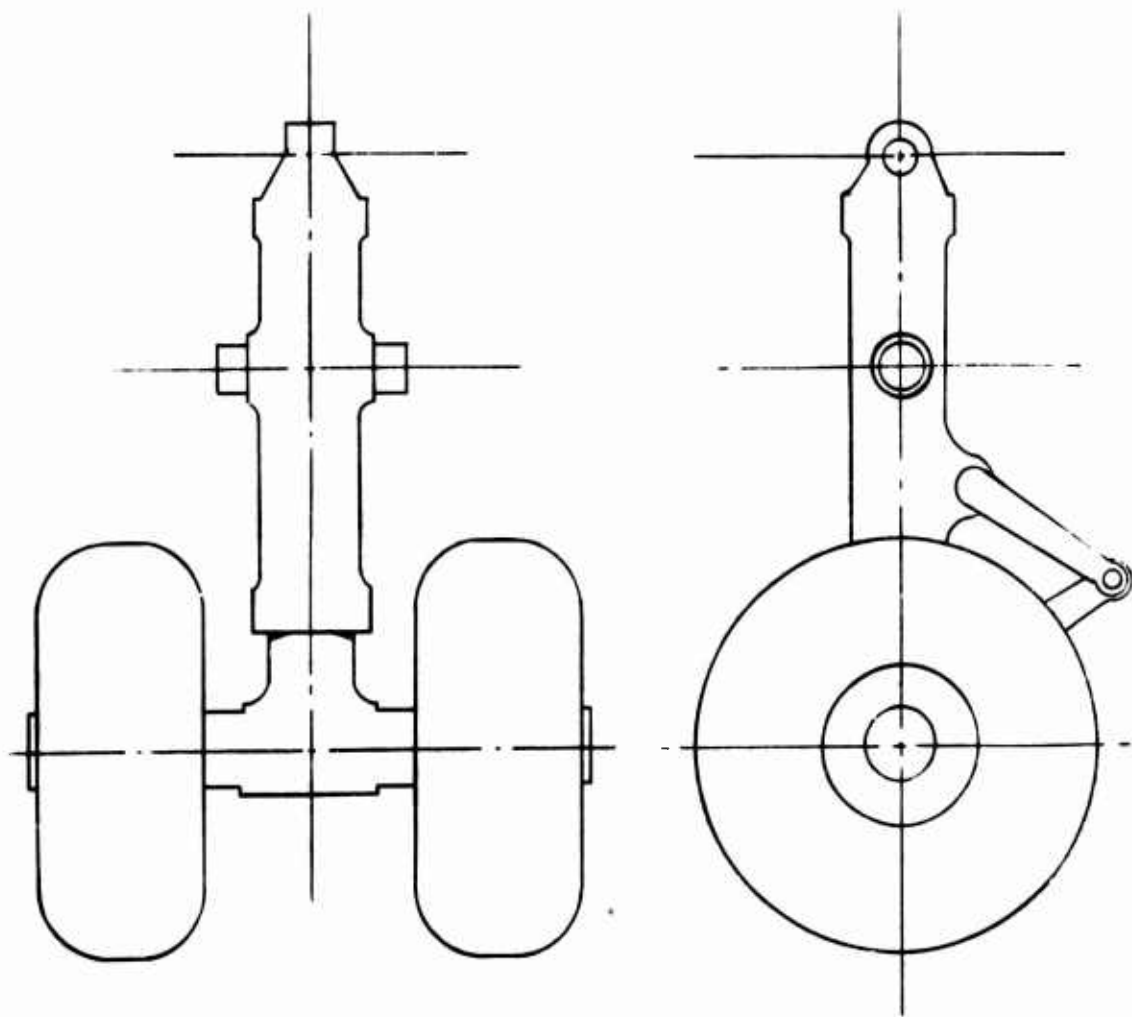

Figure 31. "T" Configuration Strut.

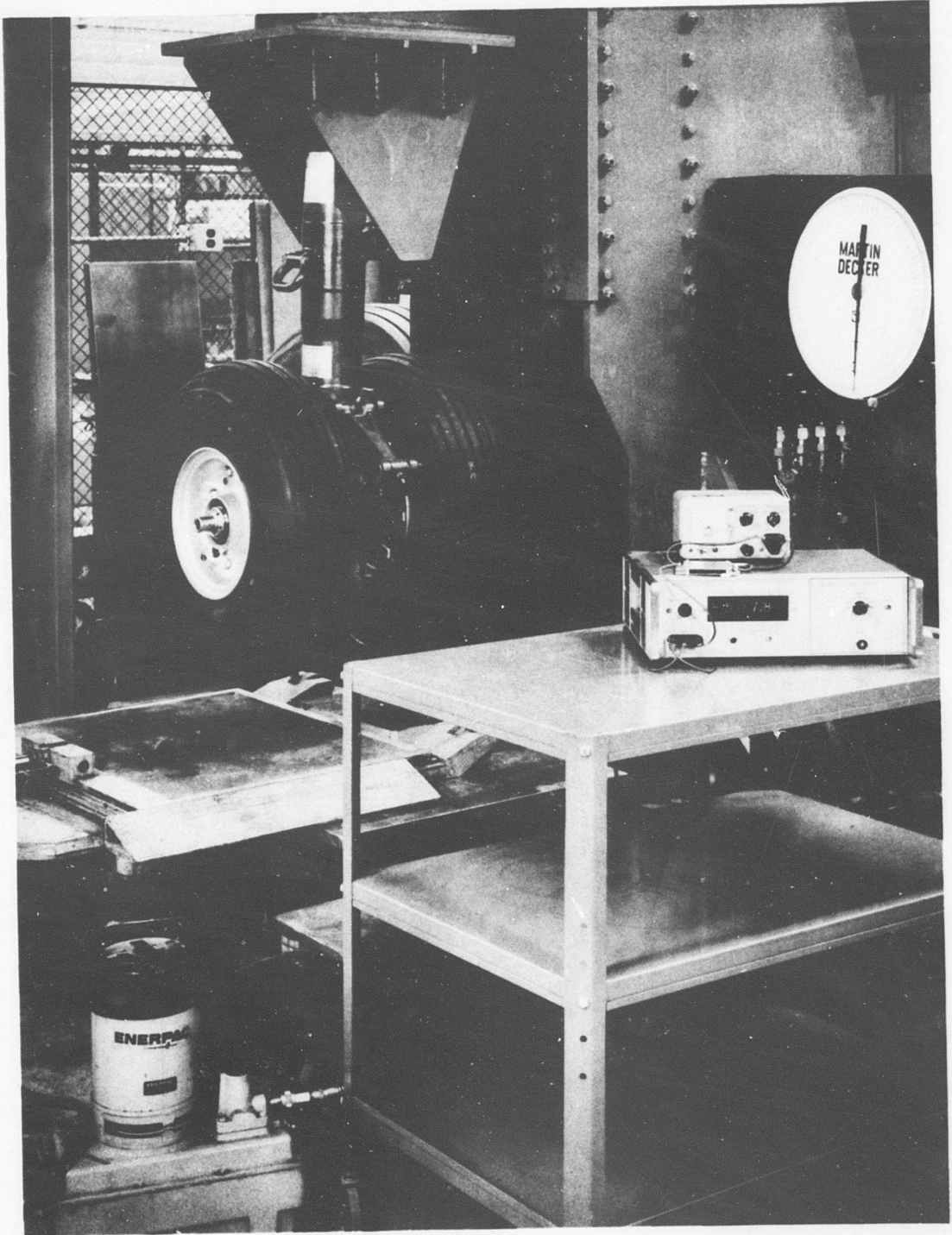

Figure 32. CH-47 Forward Landing Gear Strut Test.

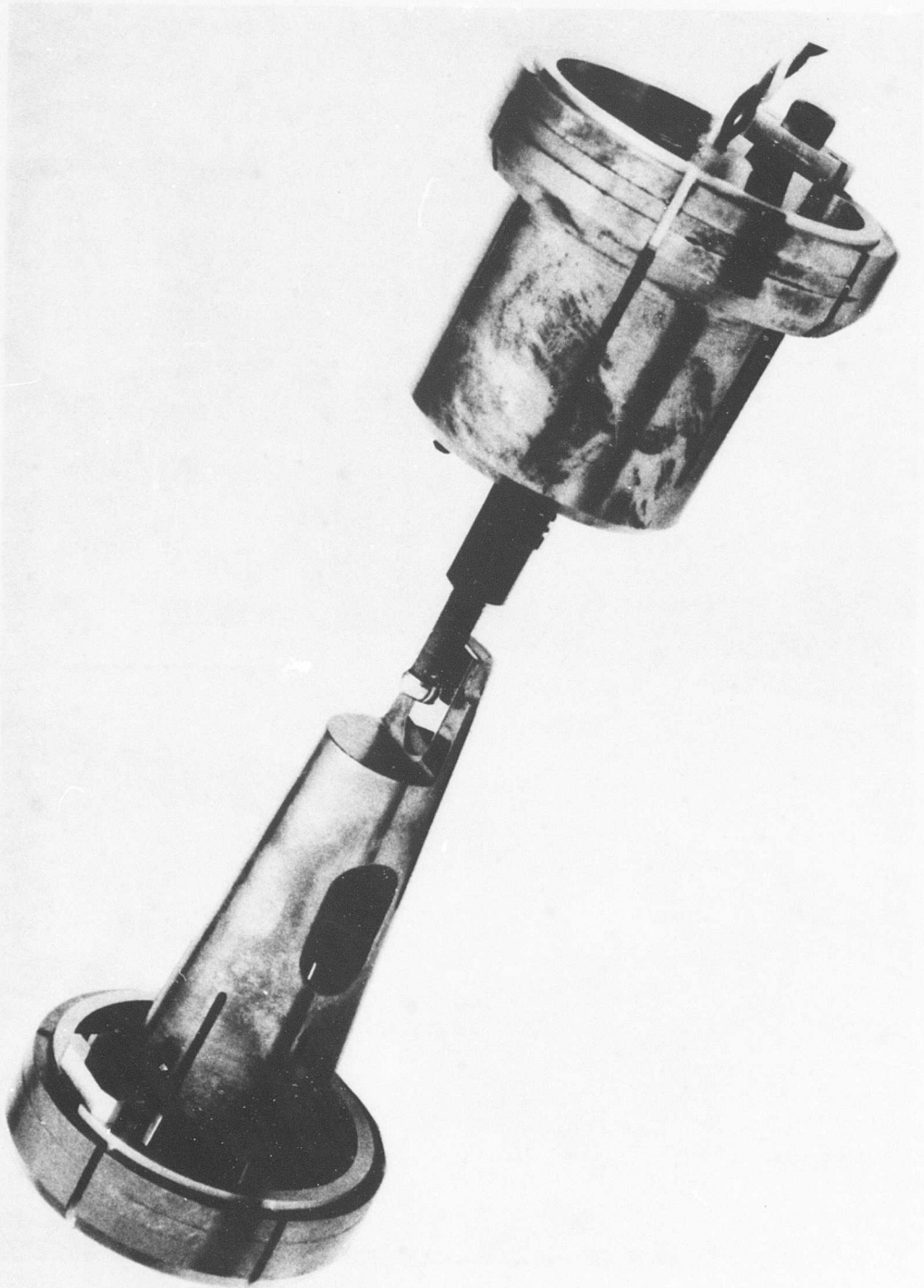

Figure 33. Typical Landing Gear Axle Instrumentation Hardware.

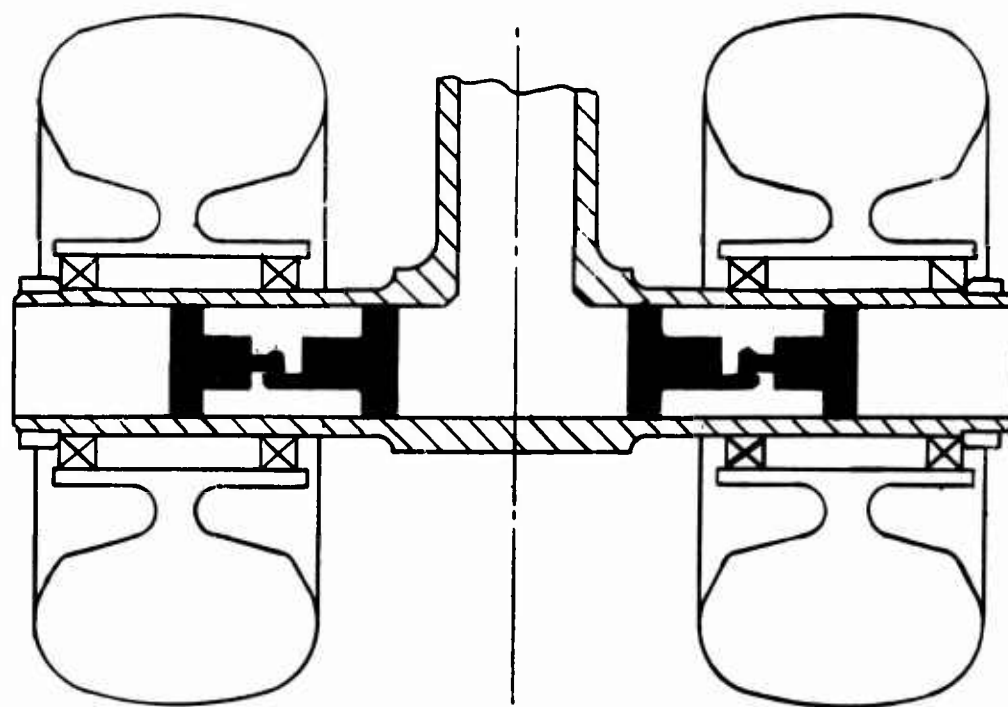

Figure 34. "T" Configuration Strut Instrumentation Installation.

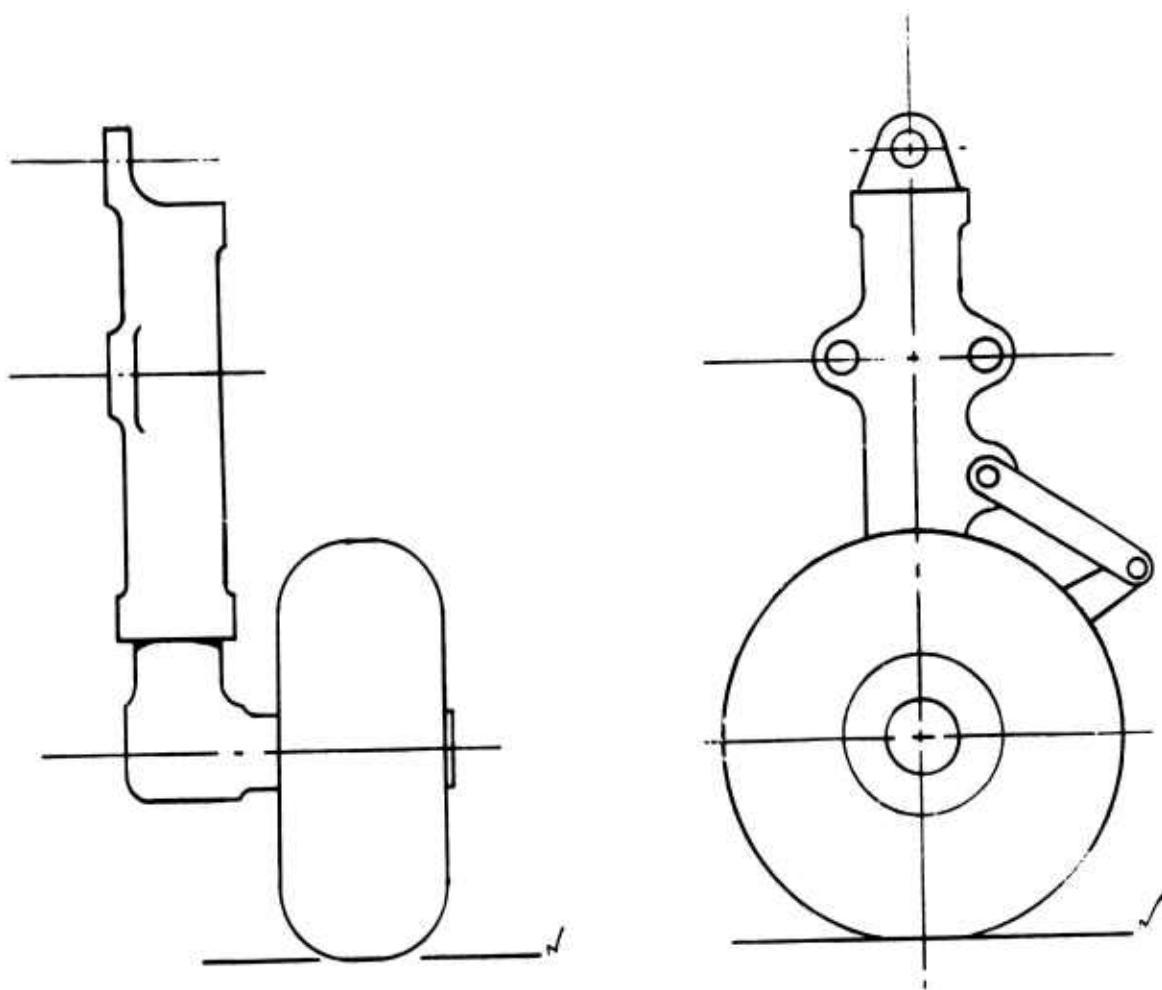

Figure 35. "L" Configuration Strut.

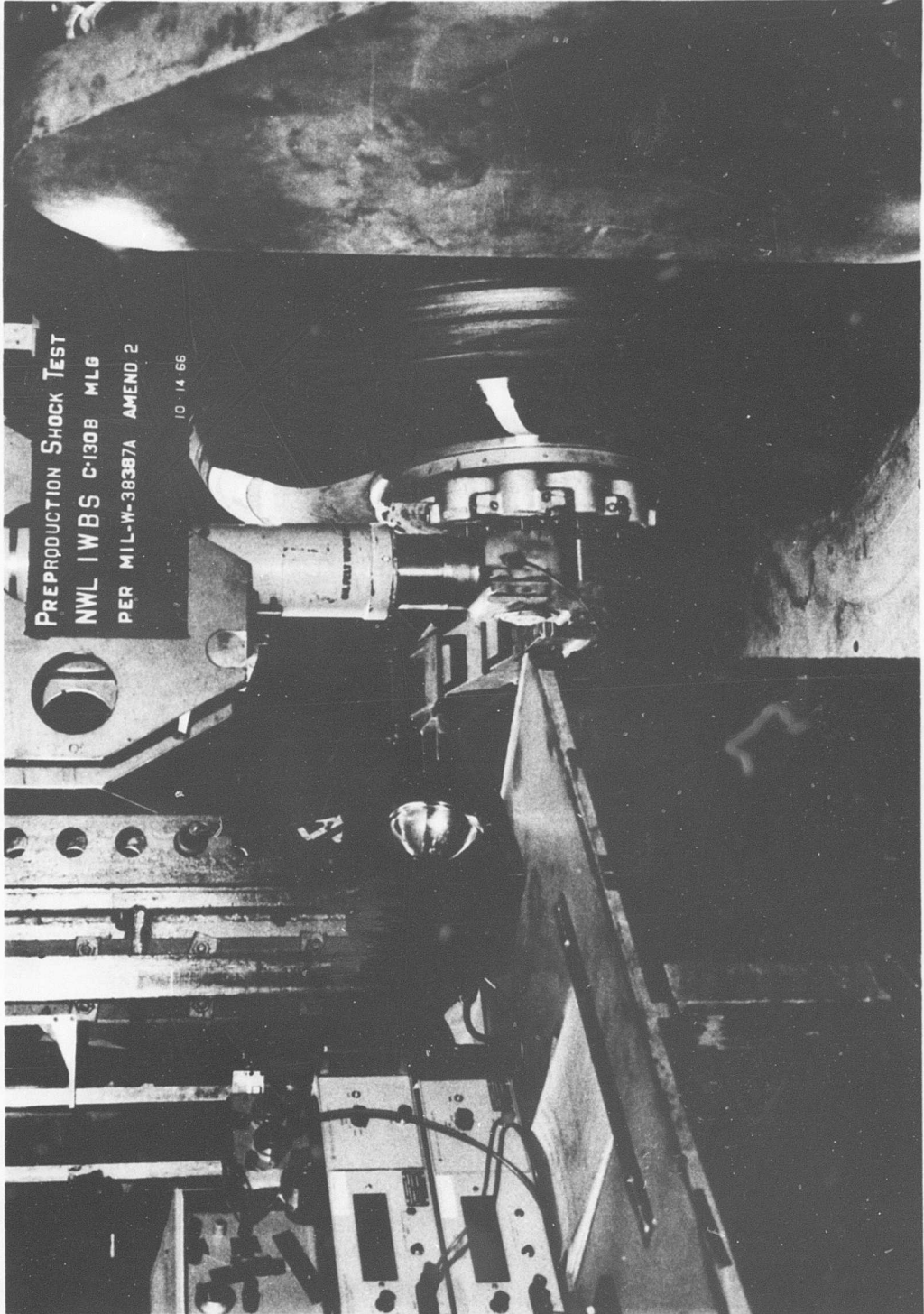

Figure 36. C-130 Main Landing Gear Preproduction Shock Test.

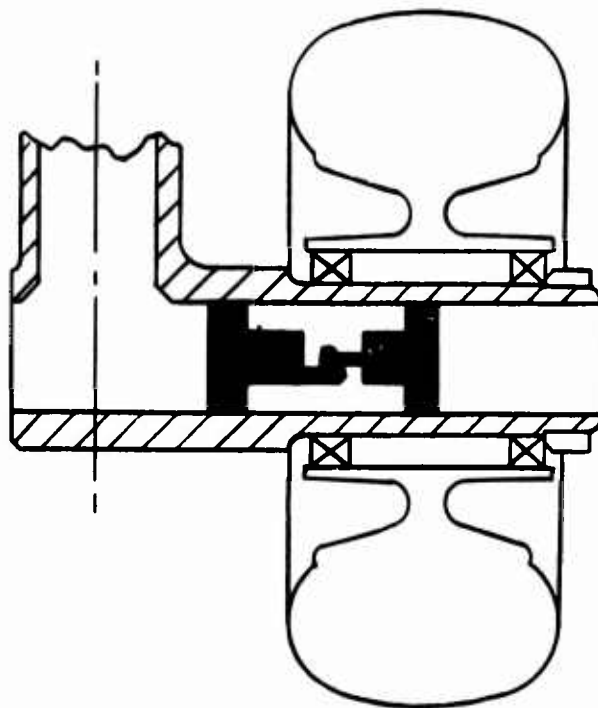

Figure 37. "L" Configuration Strut Instrumentation Installation.

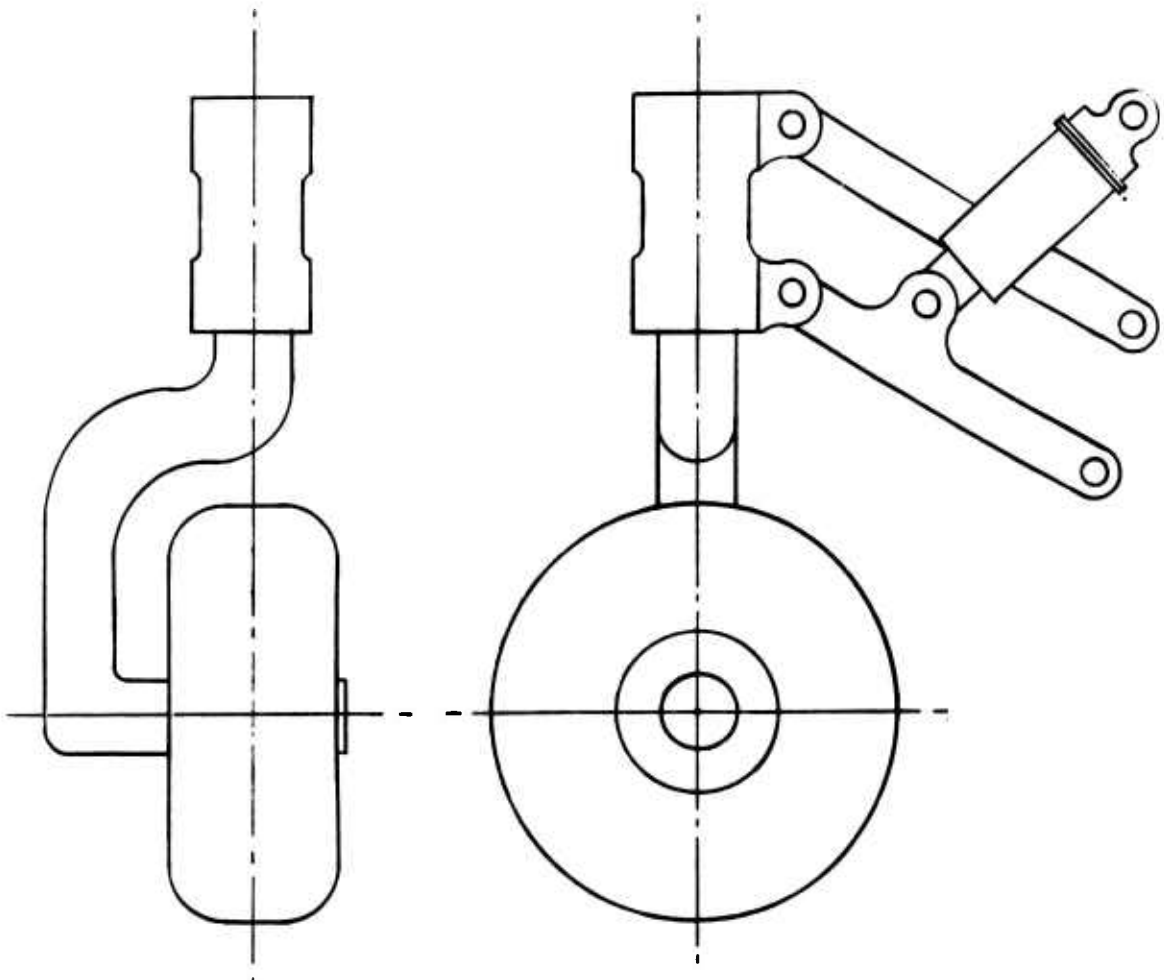

Figure 38. "L" Configuration Strut with Swivel Capability and Oleo Strut Supported Drag Link Suspension.

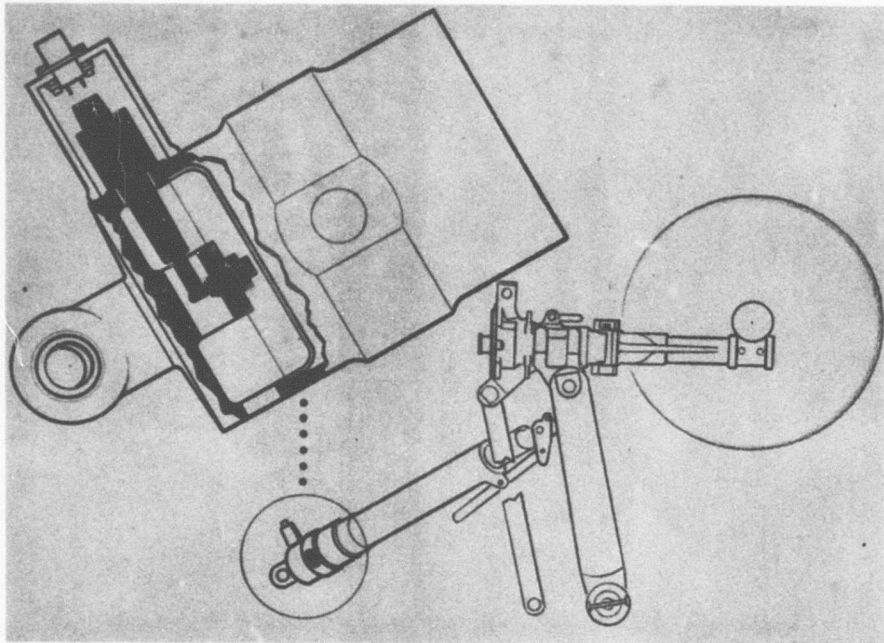
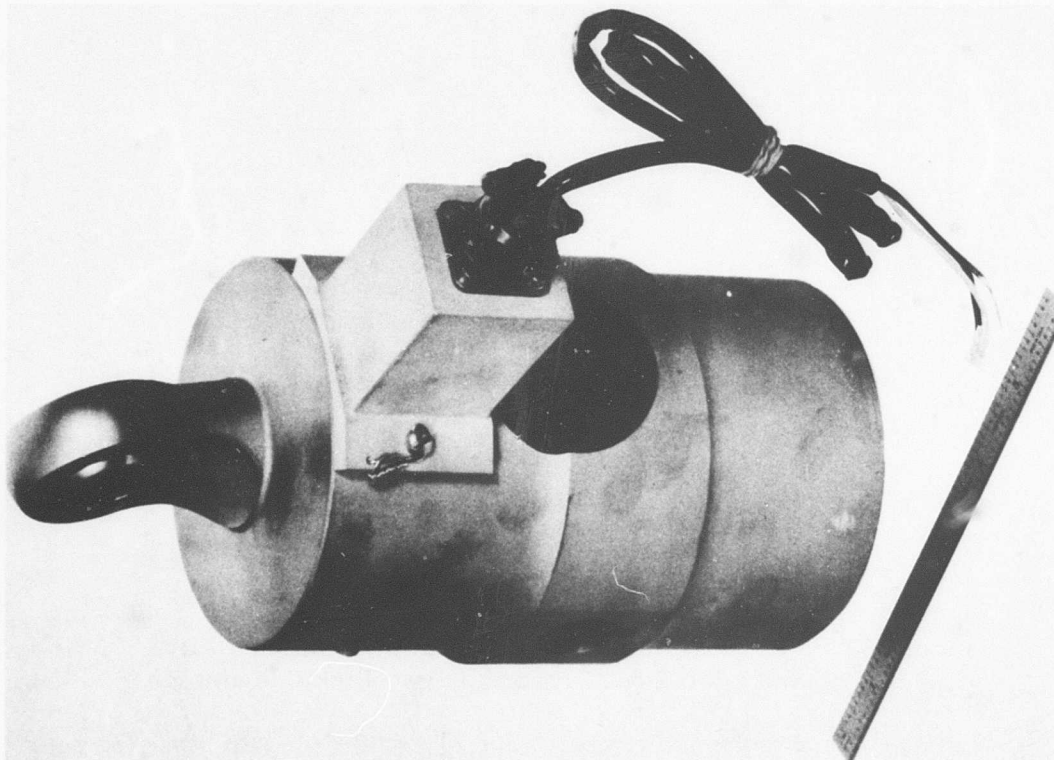

Figure 39. Instrumented Oleo Strut Top Cap.



The larger helicopters to be manufactured in the future may well utilize the four-wheel truck landing gear strut configuration shown in Figures 40 and 41. In this structural configuration, the load is concentrated on the hinge pin between the vertical strut and the longitudinal truck beam, supported at either end through the axles, wheels, and tires. This loading provides a deflection of the longitudinal beam which is proportional to the vertical load applied. Instrumentation of the longitudinal beam deflection is provided as shown in Figure 42 by using the previously described deflection sensor and instrumentation hardware relatively similar to that shown in Figure 33, with the exception that mounting is accomplished by mechanically clamping and adhesively augmenting the installation to the exterior of the beam, as shown. This instrumentation technique has been proven in test in the setup shown in Figure 41.

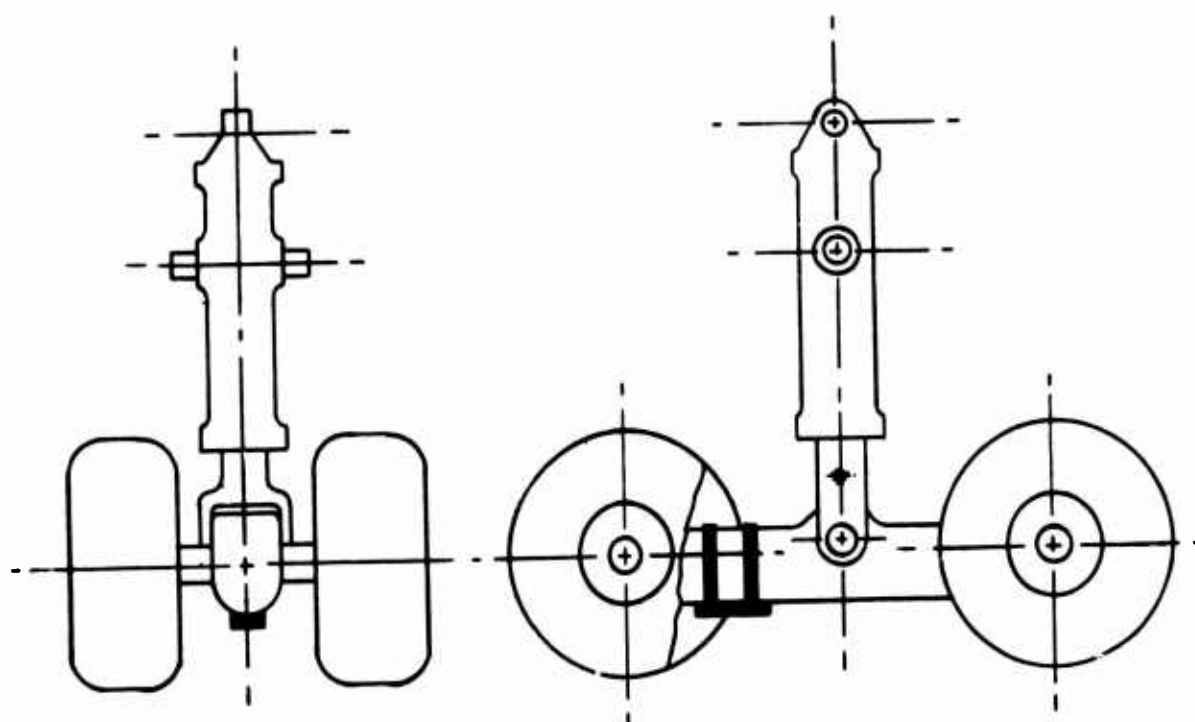

Figure 40. Four-Wheel Truck Strut.

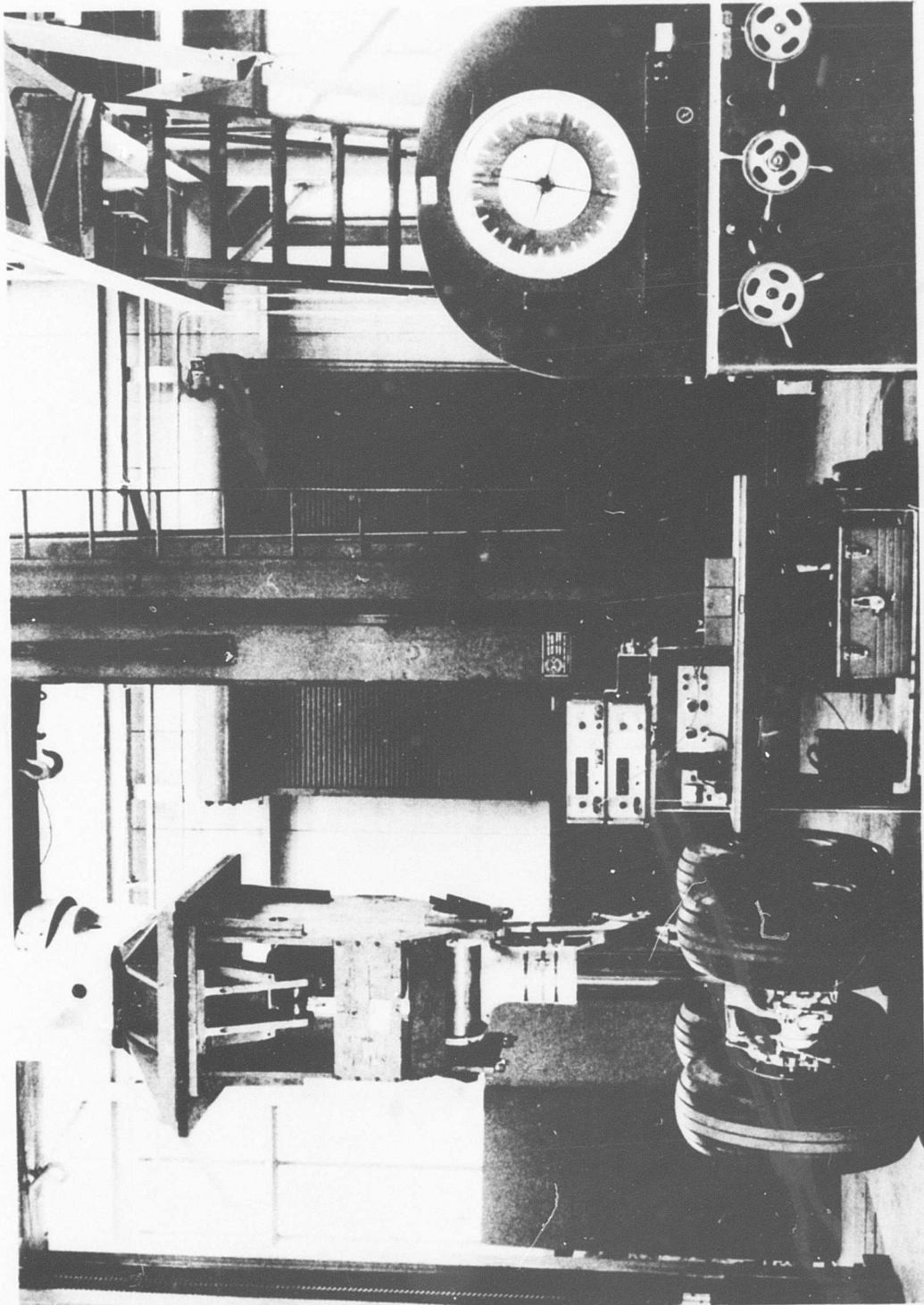

Figure 41. C-141 Main Landing Gear Instrumentation Test.

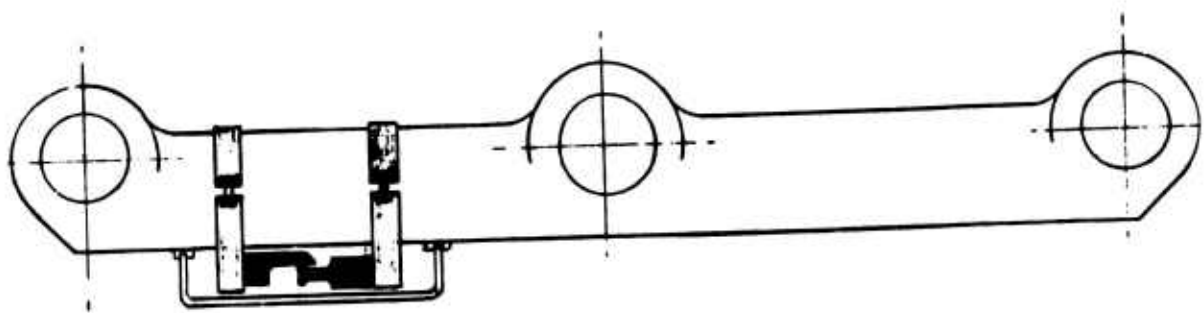

Figure 42. Four-Wheel Truck Strut Instrumentation Installation.

### TERRAIN SLOPE ERROR IN STRUT LOAD MEASUREMENT

The geometric effect of pitch slope on measured load is shown on the illustration, Figure 43.

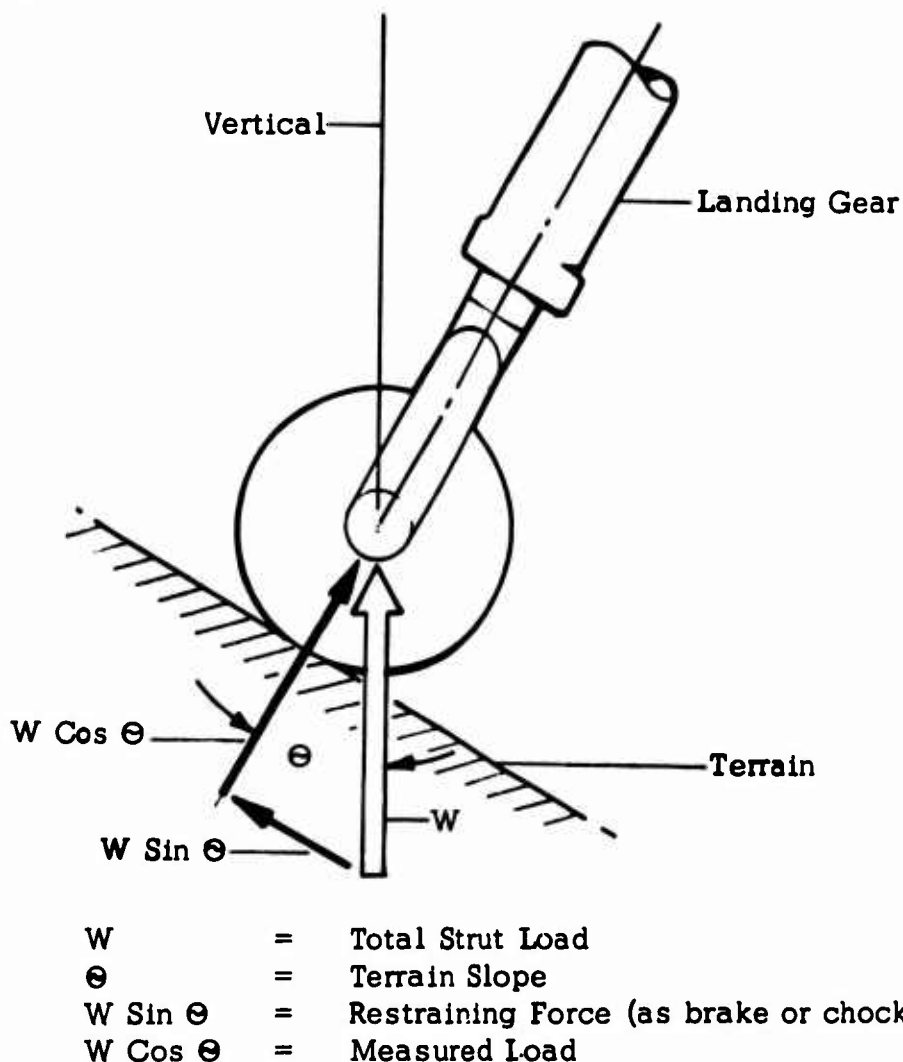

Figure 43. Terrain Slope Error in Strut Load Measurement.

Helicopter roll attitude is stated by operational personnel to be nearly level ( $\pm 3^\circ$ ) in field use on sloped terrain. Normal pitch attitude ranges from level to  $10^\circ$  nose up or nose down.

Compensation for cosine error in strut load measurement which affects the computation of gross weight and center of gravity will be discussed in the section entitled "Compensation for Terrain Slope Error in Strut Load Measurement".

### TERRAIN SLOPE ERROR IN CENTER OF GRAVITY READOUT

The geometric effect of pitch slope on computed apparent center of gravity position is shown on the illustration, Figure 44.

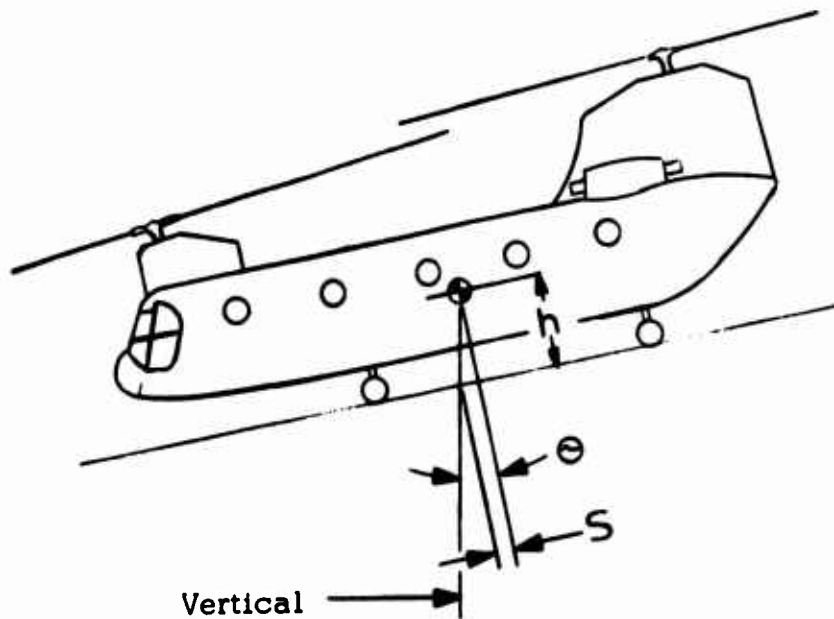

Figure 44. Terrain Slope Error in Center of Gravity Readout.

### APPARENT CENTER OF GRAVITY POSITION

The distance on the ground that the CG moves as a result of the elevation  $h$  of the CG and the angle  $\Theta$  is

$$S = h \tan \Theta \cong h \Theta$$

Correction of the computation of CG is made to provide a reading equivalent to that which would be obtained with the helicopter in its nominal horizontal attitude. The compensation signal derived from the pitch sensor, as  $(h \Theta)$ , is a linear function capable of full compensation for this apparent CG position change,  $S$ . Implementation of this correction is discussed in the section entitled "Compensation for Terrain Slope Error in Strut Load Measurement." Approximation is made for the nominal CG height  $h$  in the heavily loaded condition where CG accuracy is most important. The curve (Figure 45) shows the apparent CG change characteristic and illustrates the effect of the departure of the actual CG height from the predetermined nominal, using the CH-47 as an example.

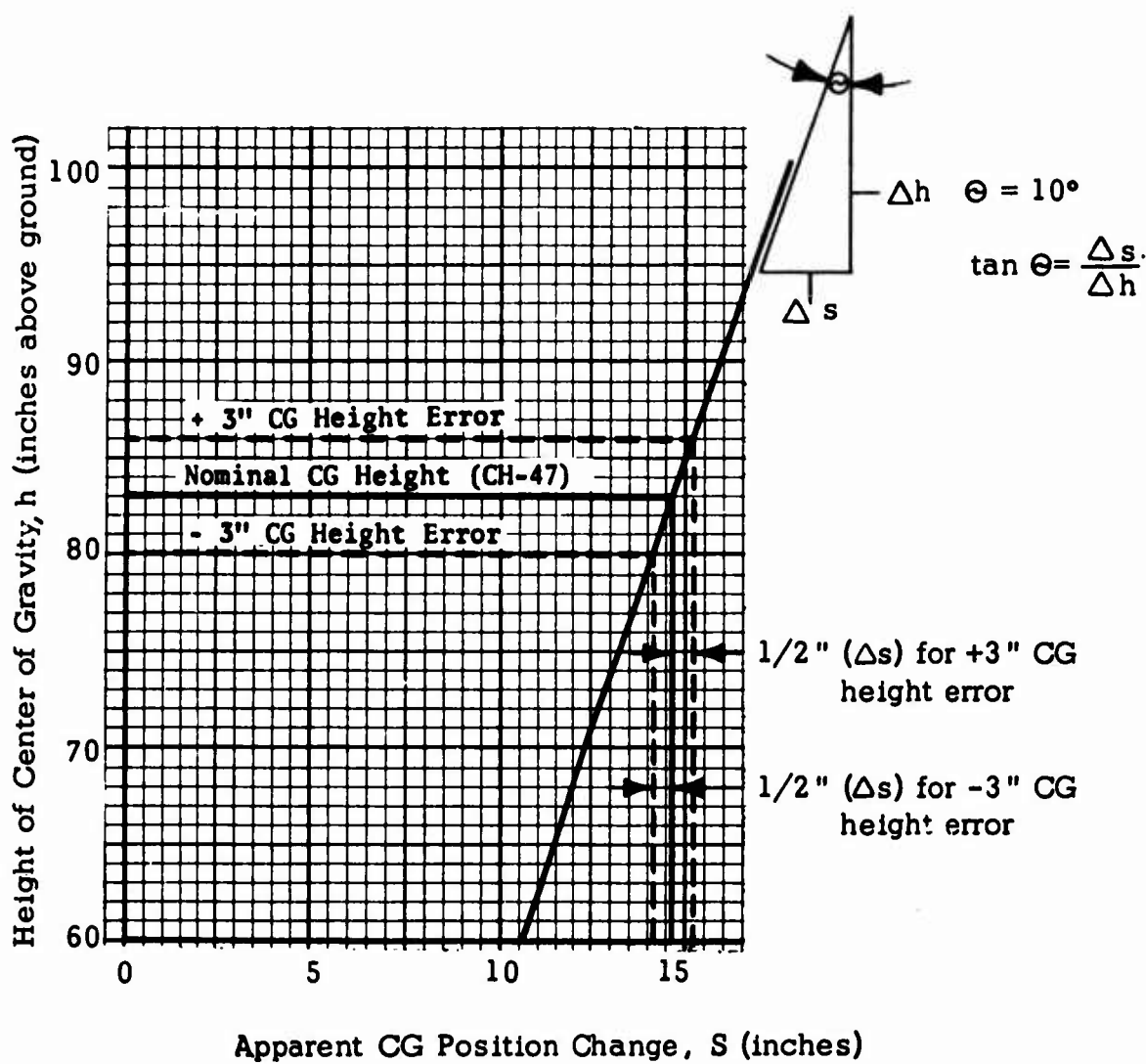

Conditions: Pitch Slope of  $10^\circ$

Figure 45. Apparent Center of Gravity Position Change Vs. Height of Center of Gravity.

## COMPENSATION FOR TERRAIN SLOPE ERROR IN STRUT LOAD MEASUREMENT

### Gross Weight and Center of Gravity Equations — Level Terrain

Equations 2 and 5 define the relationship between the measured strut forces in the computation of gross weight and center of gravity on level terrain.

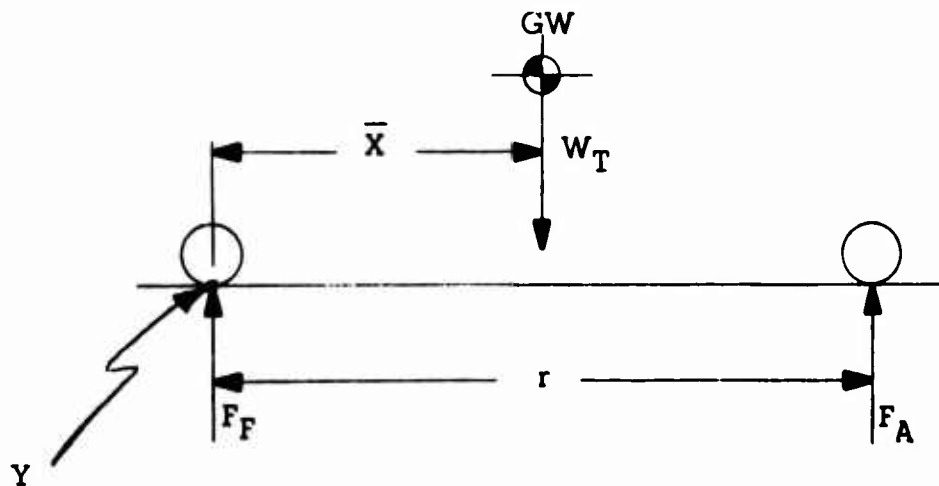

$$\text{Gross weight equation. } W_T - F_F - F_A = 0 \quad (1)$$

$$\boxed{W_T = F_F + F_A} \quad (2)$$

Center of gravity equation. Sum moments about point "Y"

$$\sum M_Y = 0 \quad (3)$$

$$\bar{X} W_T - r F_A = 0 \quad (4)$$

$$\boxed{\bar{X} = \frac{r F_A}{W_T}} \quad (5)$$

Gross Weight and Center of Gravity Equations — Sloped Terrain

Equations 6 through 18 define the relationship between the measured strut forces and pitch angle in the computation of gross weight and center of gravity on nonlevel terrain.

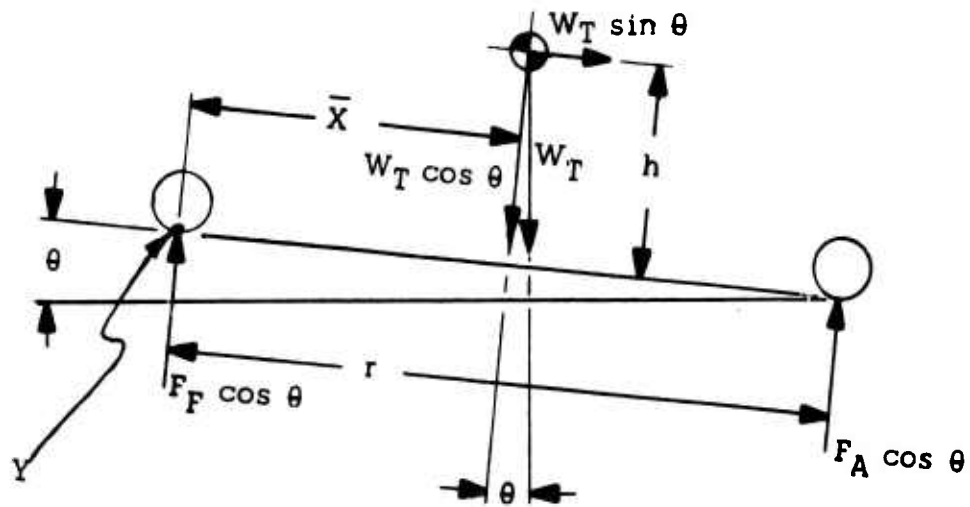

Gross weight equation: (nonlevel terrain) summation of forces perpendicular to the ground plane.

$$W_T \cos \theta = F_F \cos \theta - F_A \cos \theta = 0 \quad (6)$$

$$W_T \cos \theta = (F_F + F_A) \cos \theta \quad (7)$$

Since  $F_F \cos \theta$  and  $F_A \cos \theta$  are the measured forces, the error due to slope  $\theta$  is

$$\text{Error} = W_T - W_T \cos \theta = W_T (1 - \cos \theta) \quad (8)$$

Therefore, to obtain true  $W_T$  we must compensate for the error due to pitch angle  $\theta$  as follows:

True Weight = Measured Weight + Error

$$W_T = [F_F \cos \theta + F_A \cos \theta] + [W_T (1 - \cos \theta)] \quad (9)$$

Center of gravity equation: (nonlevel terrain)

$$M_Y = 0 \quad (10)$$

$$\bar{X} W_T \cos \theta + h W_T \sin \theta - r F_A \cos \theta = 0 \quad (11)$$

$$\bar{X} = \frac{r F_A \cos \theta}{W_T \cos \theta} - h \tan \theta \quad (12)$$

From equation 9,  $W_T \cos \theta$  is corrected to  $W_T$ .

Equation 12 becomes

$$\bar{X}_S = \frac{r F_A \cos \theta}{W_T} - h \tan \theta \quad (13)$$

The error in center of gravity resulting from pitch slope is

$$\text{Error} = \bar{X}_{\text{Slope}} - \bar{X}_{\text{Level}} \quad (14)$$

$$= \frac{r F_A \cos \theta}{W_T} - h \tan \theta - \frac{r F_A}{W_T} \quad (15)$$

$$= \frac{r}{W_T} F_A (\cos \theta - 1) - \frac{h}{r} W_T \tan \theta \quad (16)$$

Therefore, to obtain true center of gravity position ( $\bar{X}$ ), we must compensate for the error due to the pitch angle  $\theta$  as follows:

$$\text{True } \bar{X} = \text{Measured } \bar{X} + \text{Error} \quad (17)$$

$$\bar{X} = \left[ \frac{r F_A \cos \theta}{W_T} \right] + \left[ \frac{r}{W_T} \left\{ F_A (\cos \theta - 1) - \frac{h}{r} W_T \tan \theta \right\} \right] \quad (18)$$

Mechanization of compensation for terrain slope error is shown in Figure 46.

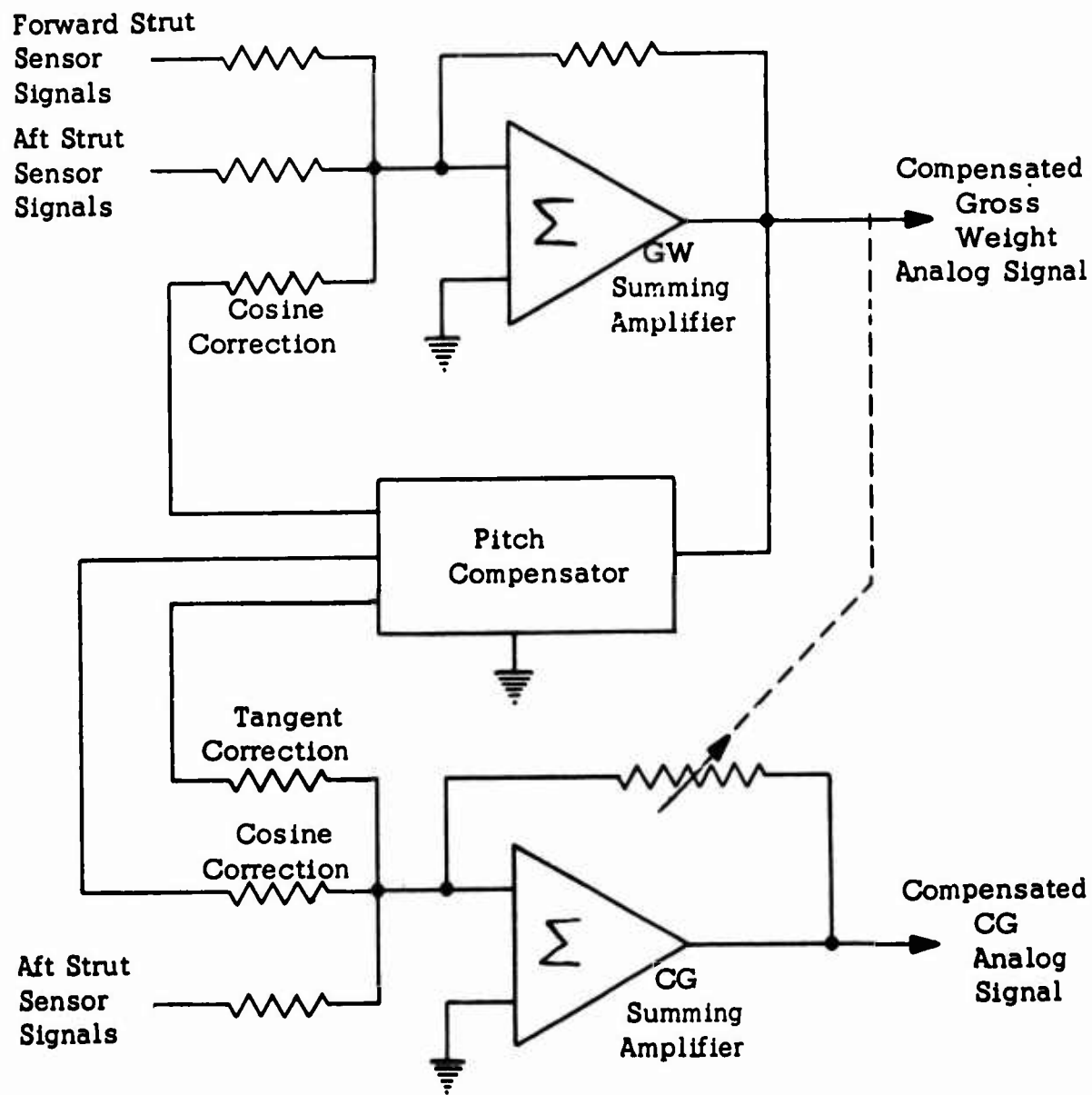

Figure 46. Mechanization of Compensation for Terrain Slope Error.

Compensation for terrain slope error is achieved by using a pitch sensor combined with suitable electronics to provide the required functions of the measured aircraft pitch angle. The error induced in the measurement of strut load as a function of pitch attitude is shown in Figure 11. The measurement error can be fully compensated by using a nonlinear (cosine) correction. A linear approximation of the  $(1 - \cos \theta)$  error can compensate for pitch angles up to  $10^\circ$  within 0.25%.

#### CORRECTION TECHNIQUES FOR ROTOR LIFT EFFECT DURING WEIGHT AND BALANCE MEASUREMENT

Weight and balance measurements obtained during rotor operation will have large errors due to lift effect. Lift effect varies as a function of rotor speed, cyclic pitch, collective pitch, pressure altitude, and temperature.

Correction for lift effect can be achieved by using lift correction charts, electrical lift correction without density altitude compensation, or electrical lift correction with density altitude compensation. For maximum utility, the approach using electrical correction with density altitude compensation is preferred. The three lift error correction methods are discussed in this section.

#### Correction Charts

A chart can provide rotor lift correction values for specific temperature and pressure altitude conditions. These values must be manually added to the gross weight reading obtained with the rotor operating from an integral weight and balance system without integral lift correction capability.

The disadvantages of this correction method are the need for manual computation and the attendant possibility of error or neglecting to perform the correction. Table VI illustrates a typical format for this correction data, using the characteristics of the CH-47A as an example. A chart would be provided for correction of error at each RPM under which weighing would normally take place.

Correction of measured center of gravity for rotor lift effect would require a means capable of providing a fixed cyclic pitch stick longitudinal control position. An annunciator light can be used to indicate the manual return of the cyclic pitch stick control to a preselected longitudinal position. This control position will command a fixed proportion of lift on the forward and aft struts and will enable computation of the apparent center of gravity position. The apparent center of gravity position read on the indicator must be corrected for the effect of density altitude by means of a chart similar in format to that for the gross weight correction.

TABLE VI  
LIFT EFFECT CORRECTION CHART FOR CH-47A

GROSS WEIGHT INCREMENTS					
Rotors at 230 RPM and +3° Collective Pitch					
Pressure Altitude (ft.)	Temperature ° C				
	5	15	25	35	45
0	6830	6600	6350	6170	5960
2000	6350	6120	5930	5730	5550
4000	5900	5700	5500	5330	
6000	5480	5280	5110	4940	
8000	5070	4900	4740		
10000	4710	4540			

Electrical Lift Correction  
Without Density Altitude Compensation

This method will fully correct for rotor lift effect during weighing at the point of origin of the mission. The magnitude of this effect for the CH-47, for example, is on the order of 6,000 pounds.

Variation in density altitude at the origin of the mission compared to that at each landing area within the mission will provide errors in the weight and center of gravity readings. The gradient of this error is 187 pounds of lift per 1000 foot density altitude for the CH-47A, as shown in Figure 47. Correction of the density altitude errors can be made if desired by reference to charts similar to those discussed in the section entitled "Correction Charts."

Figure 48 illustrates the application of correction potentiometers for compensation of gross weight and center of gravity readings for lift effect. Offset signals from the potentiometers are fed to the corresponding summing amplifiers to restore static gross weight and center of gravity readings during rotor operation. The simple adjustment technique is described in the section entitled "Electrical Lift Correction With Density Altitude Compensation."

The lift correction switch enables the correction signal to be applied during rotor operation (switch in "ON" position) or to be removed for static weighing (switch in "OFF" position).

This approach for lift correction provides a system with somewhat limited utility. If the helicopter mission is performed within an area having a

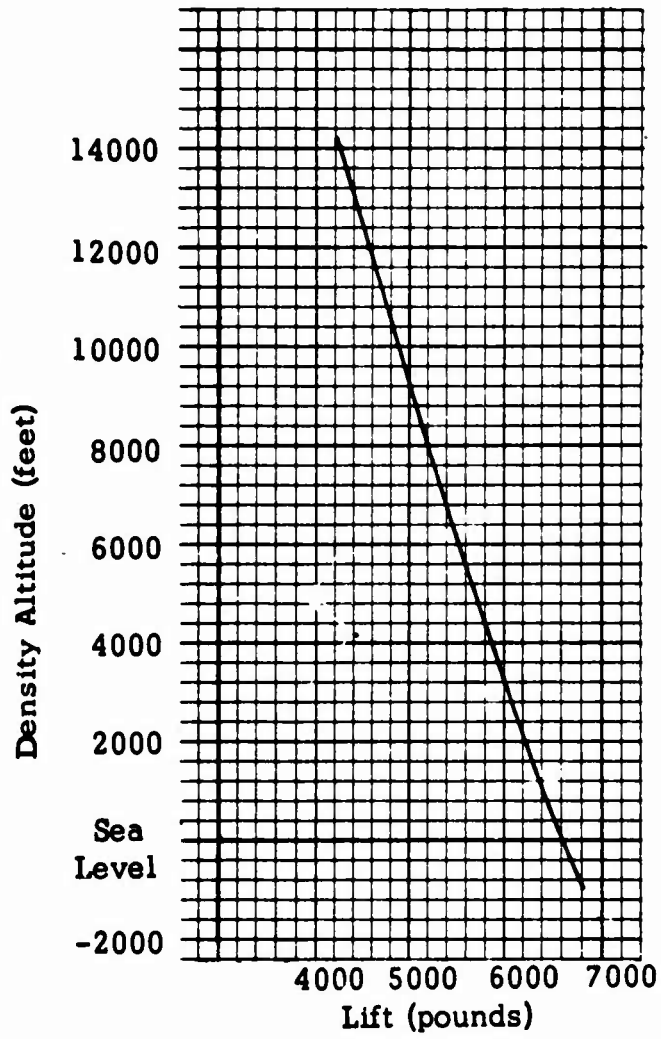

Gradient  
187 lb./1000 ft. D.A.

Conditions

Rotor Speed: 230 RPM  
3° Collective Pitch

Figure 47. Density Altitude Vs. Lift, CH-47 Helicopter.

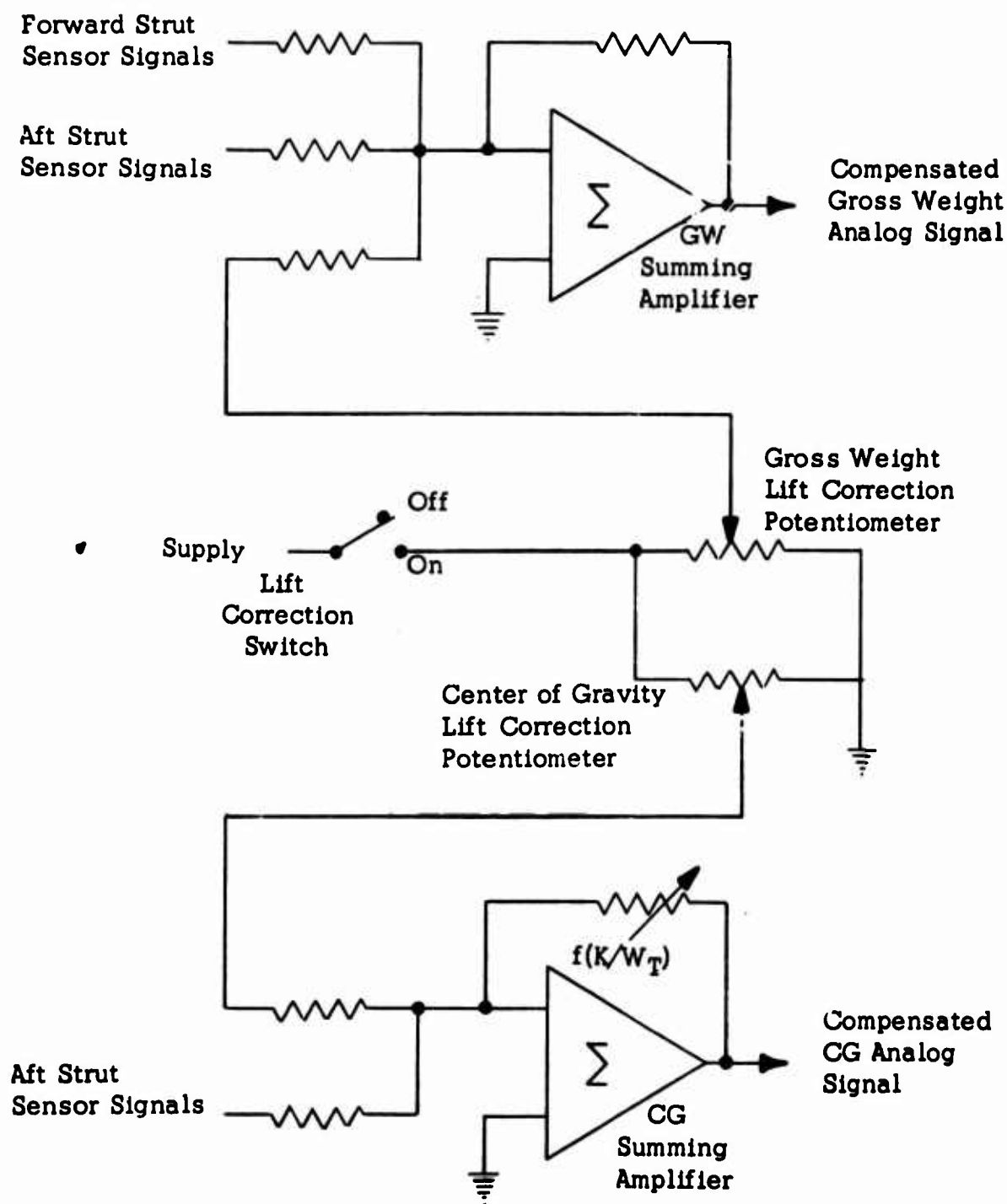

Figure 48. Correction of Lift Effect — Without Density Altitude Compensation (for weighing during rotor operation with fixed collective pitch and fixed RPM).

variation in density altitude of less than  $\pm 2000$  feet, the resulting gross weight error, in the case of the CH-47B, is less than  $\pm 1\%$  at maximum load.

#### Electrical Lift Correction With Density Altitude Compensation

Correction of the rotor lift effect during weighing can be made to include compensation for density altitude variations from the origin of the mission to the subsequent landing sites used.

Basic lift correction potentiometer adjustments for gross weight and center of gravity are made by the pilot at the start of the mission. Data are provided from a pressure altitude sensor and a temperature sensor to compensate for density altitude changes. An alternative to the use of the pressure altitude and temperature sensors exists, since density altitude data (pressure altitude and outside air temperature) are available from instruments present in the helicopter cockpit. These data could be used in setting individual potentiometers against graduated scales to compensate for density altitude changes encountered in the mission.

The illustration of the cockpit display and controls for the integral weight and balance system in Figure 49 shows the lift correction potentiometer control knobs for gross weight and center of gravity correction, the lift correction switch, and the lift balance annunciator (LIFT BAL).

The step-by-step procedure for correction for rotor lift during gross weight and center of gravity measurement is shown in Figure 50. The application of the lift correction potentiometers to the system is shown in Figure 51.

#### CALIBRATION/COMPUTER PACKAGE

The calibration/computer package in the recommended helicopter integral weight and balance system is shown in Figure 52. Its relative size with regard to the indicator and control packages is indicated. Figure 53 is an installation drawing of the calibration/computer package.

Interconnection of this package to the other system components is provided through a pair of connectors on the rear surface of the unit. Access to the plug-in modules contained within the package is gained by removing a single retaining screw and pulling the front plate and chassis from the tubular protective cover. Mounted on the chassis is a plug-in calibration potentiometer module which is removable for reinstallation in a replacement calibration/computer package. This allows retention of the calibration adjustments which have been made with respect to the characteristics of

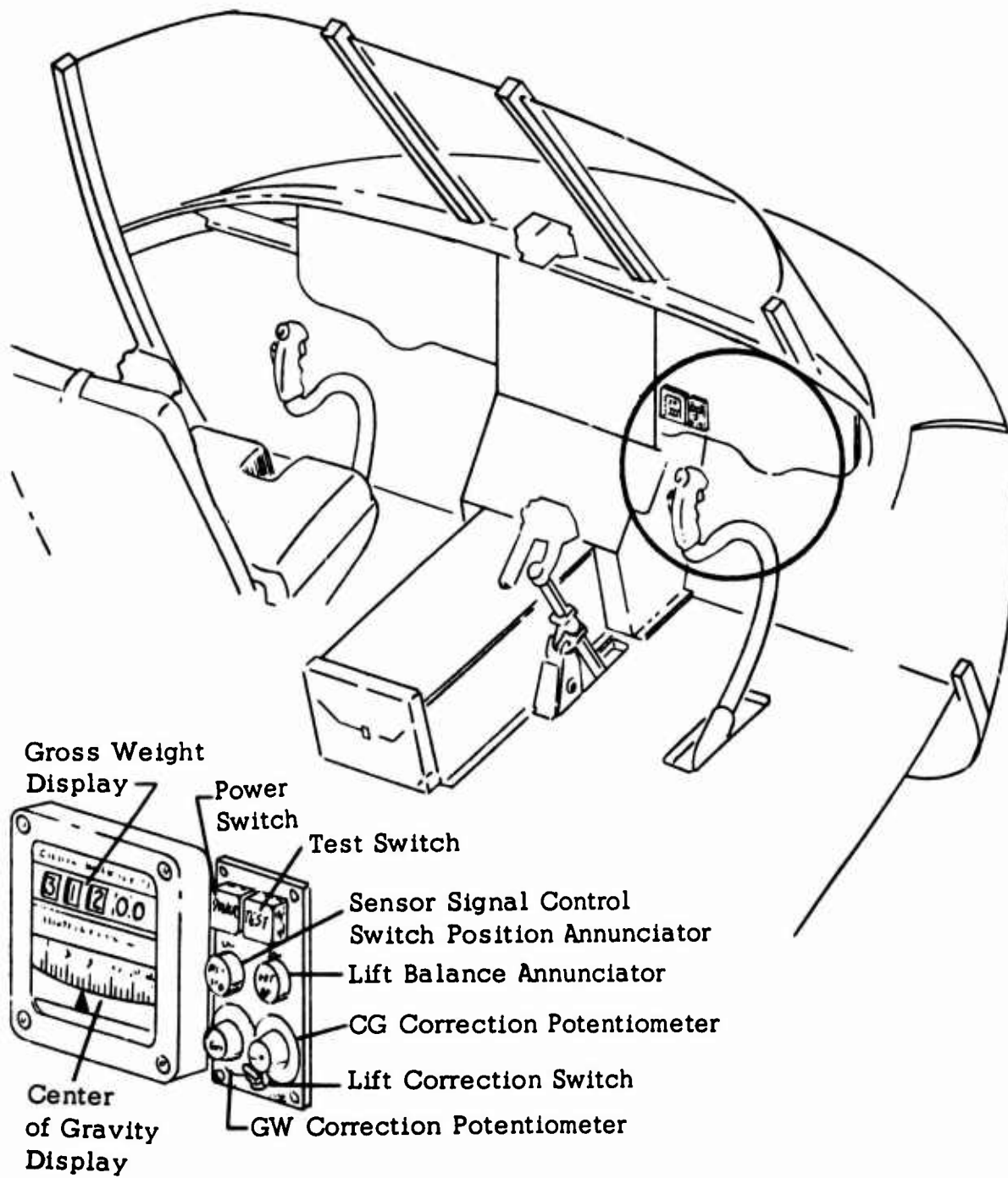
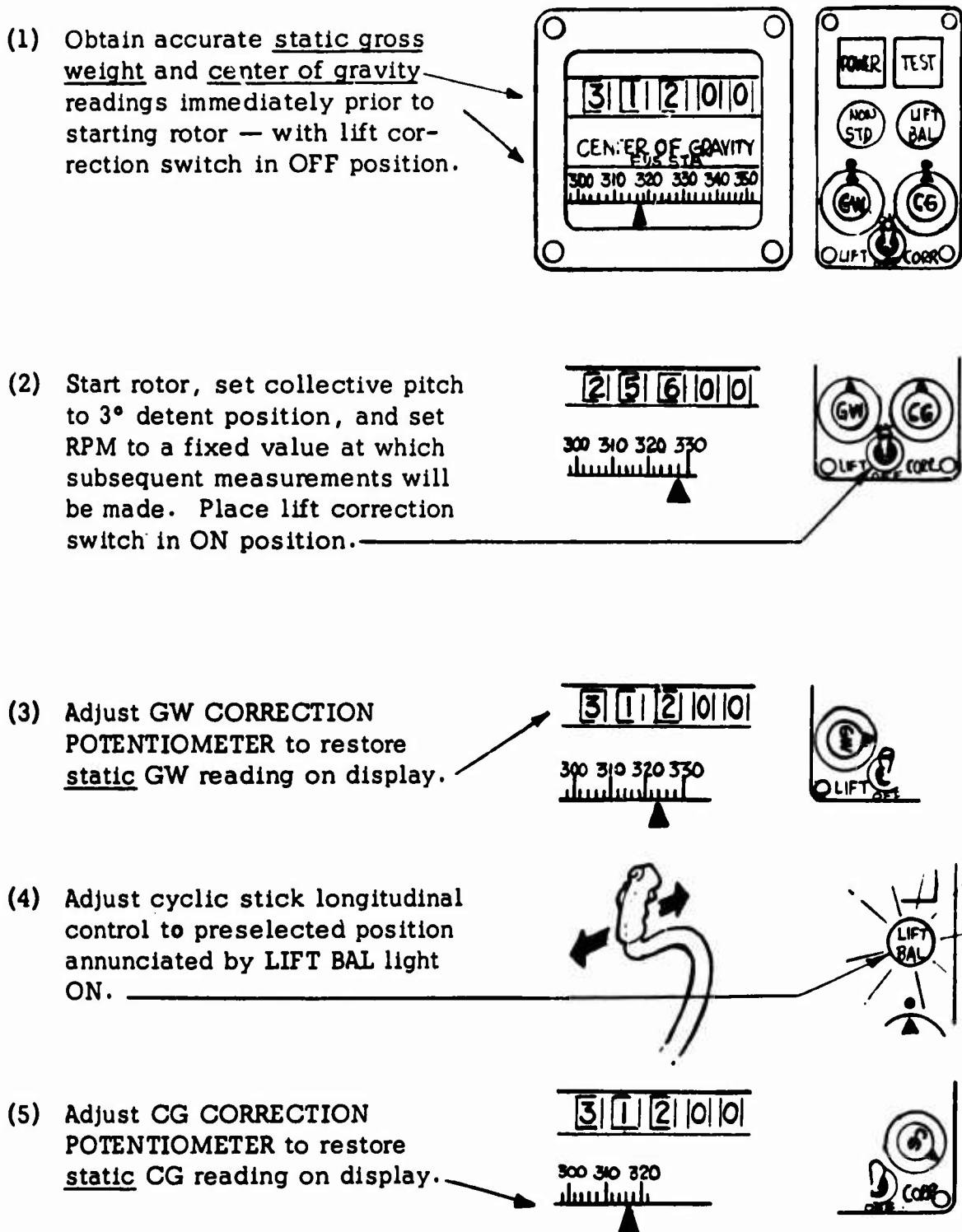

Figure 49. Cockpit Display and Controls for Integral Weight and Balance System.



All readings of GW and CG at all landings within the mission until the rotor is stopped are made using the above lift corrections.

Figure 50. Correction for Rotor Lift During GW and CG Measurement.

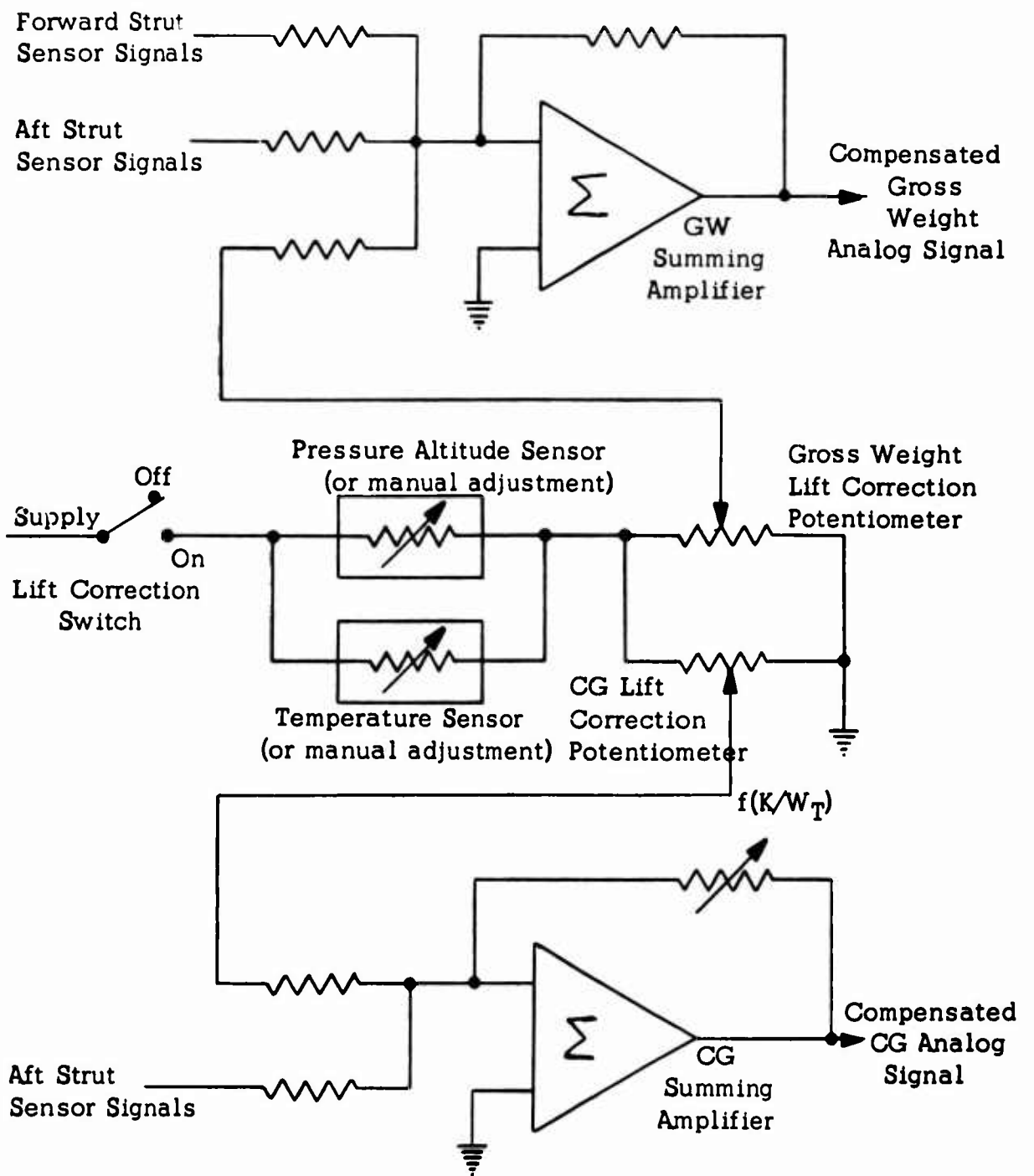

Figure 51. Correction of Lift Effect — with Density Altitude Compensation (for weighing during rotor operation with fixed collective pitch and fixed RPM).

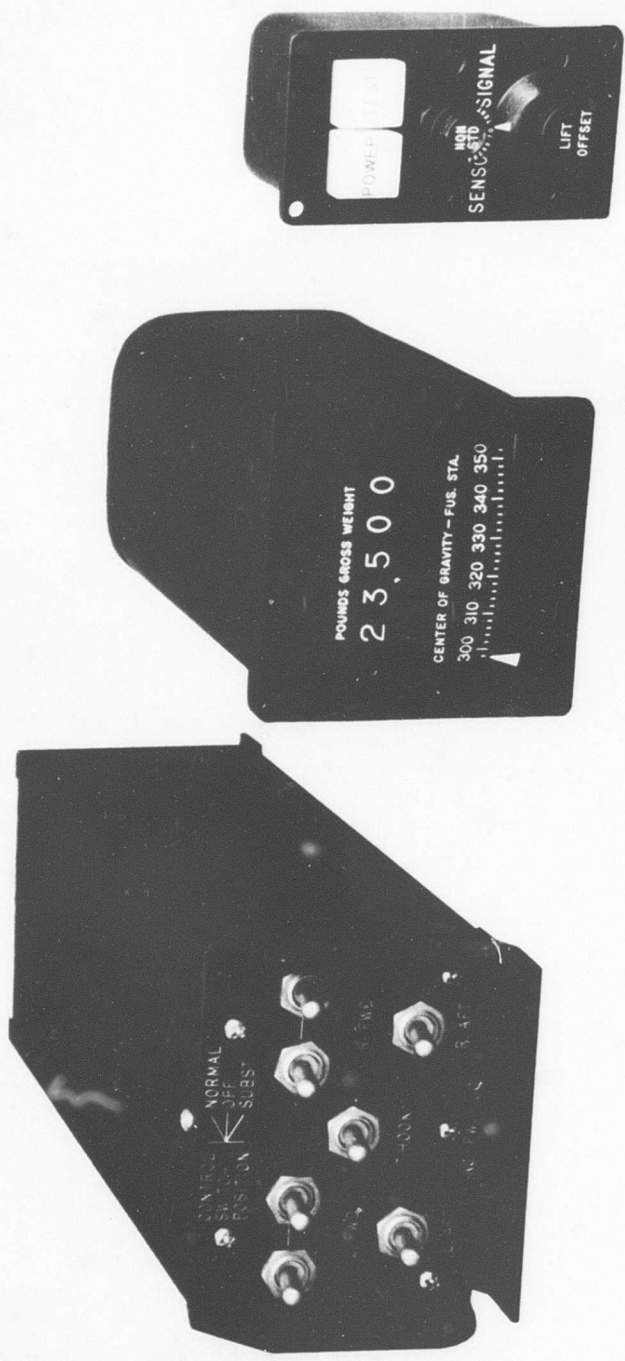

Figure 52. System Components -- CH-47  
Integral Weight and Balance System.

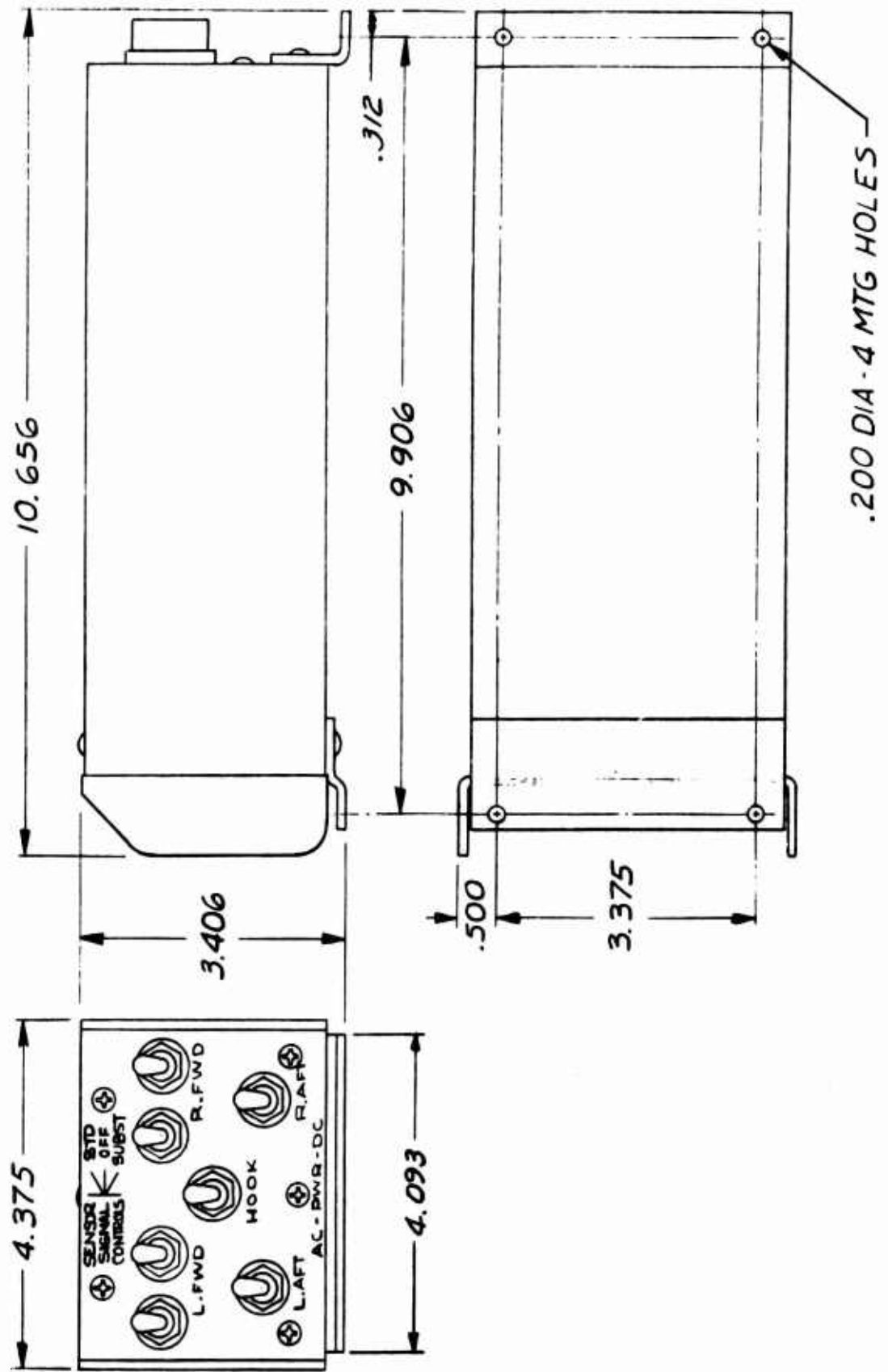

Figure 53. Calibration/Computer Package.

the particular landing gear strut structures involved. Summing amplifiers are provided on a separate plug-in module, as are power supply components on the third module.

Sensor signal control switches are provided on the front panel of the calibration/computer package to permit the individual readout of strut sensor signals, as desired, for test purposes. An additional capability provided is that of substituting a doubled signal output from a sensor to replace that lost in a failed sensor, if this should become necessary. Thus, at a somewhat reduced accuracy, it is possible to continue with the integral weight and balance system.

#### GROSS WEIGHT AND CENTER OF GRAVITY INDICATOR

Display of helicopter gross weight and center of gravity in the recommended integral weight and balance system is provided on the indicator shown in Figures 17, 52 and 54. The package employed is a standard 3-1/4-inch-square aeronautical instrument case in accordance with MS 33156. This case allows the installation of the integral weight and balance system readout on the helicopter instrument panel for reading by the pilot or copilot prior to takeoff or in flight with a load on the instrumented cargo hook. Additional display packages can be mounted for remote use. The instrument is internally lighted for night use.

The gross weight servo drives a two-gang potentiometer. One potentiometer is used as the servo follow-up and the other is used in the computation of center of gravity for display on the meter mechanism. The meter mechanism used in this instrument has been designed for high vibration environment and has a pointer natural frequency of over 80 cps. The high torque mechanism is capable of driving rugged moving coil bearings which provide immunity to vibration and shock failure. The pointer display provides excellent stability with vibration input. Parallax problems are avoided as a result of the pointer operating adjacent to a scale whose curvature is that of the pointer radius. Figure 52 shows that the readability of the display is excellent. The gross weight is read out in increments of 100 pounds, and the center of gravity is read out in increments of 2 inches.

#### PITCH COMPENSATOR

Compensation of the gross weight and center of gravity computations for errors induced by nonlevel pitch attitude of the helicopter is accomplished in the recommended system configuration by using the pitch sensor shown in Figure 55.

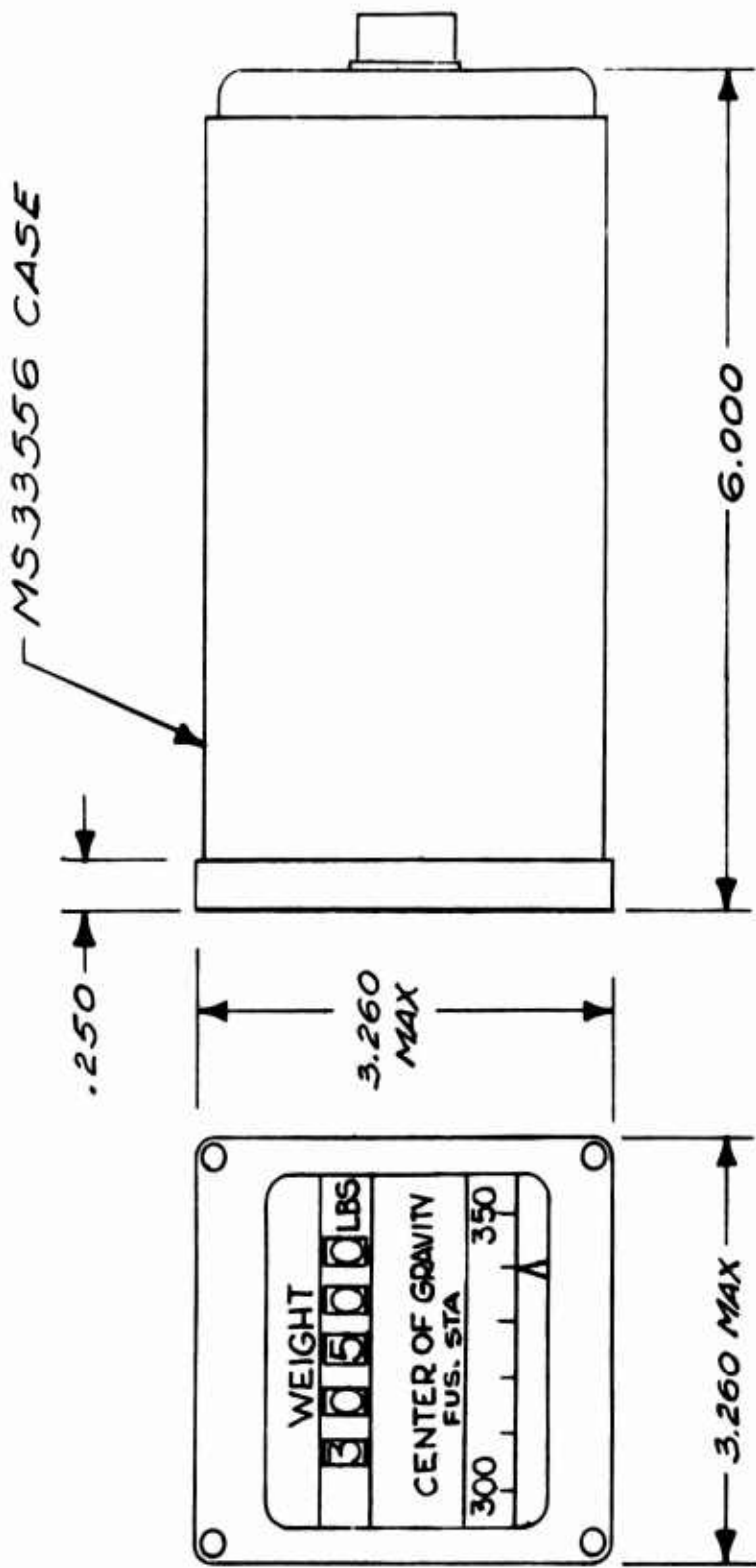

Figure 54. Weight and Center of Gravity Indicator - Servo and Meter Mechanism Display.

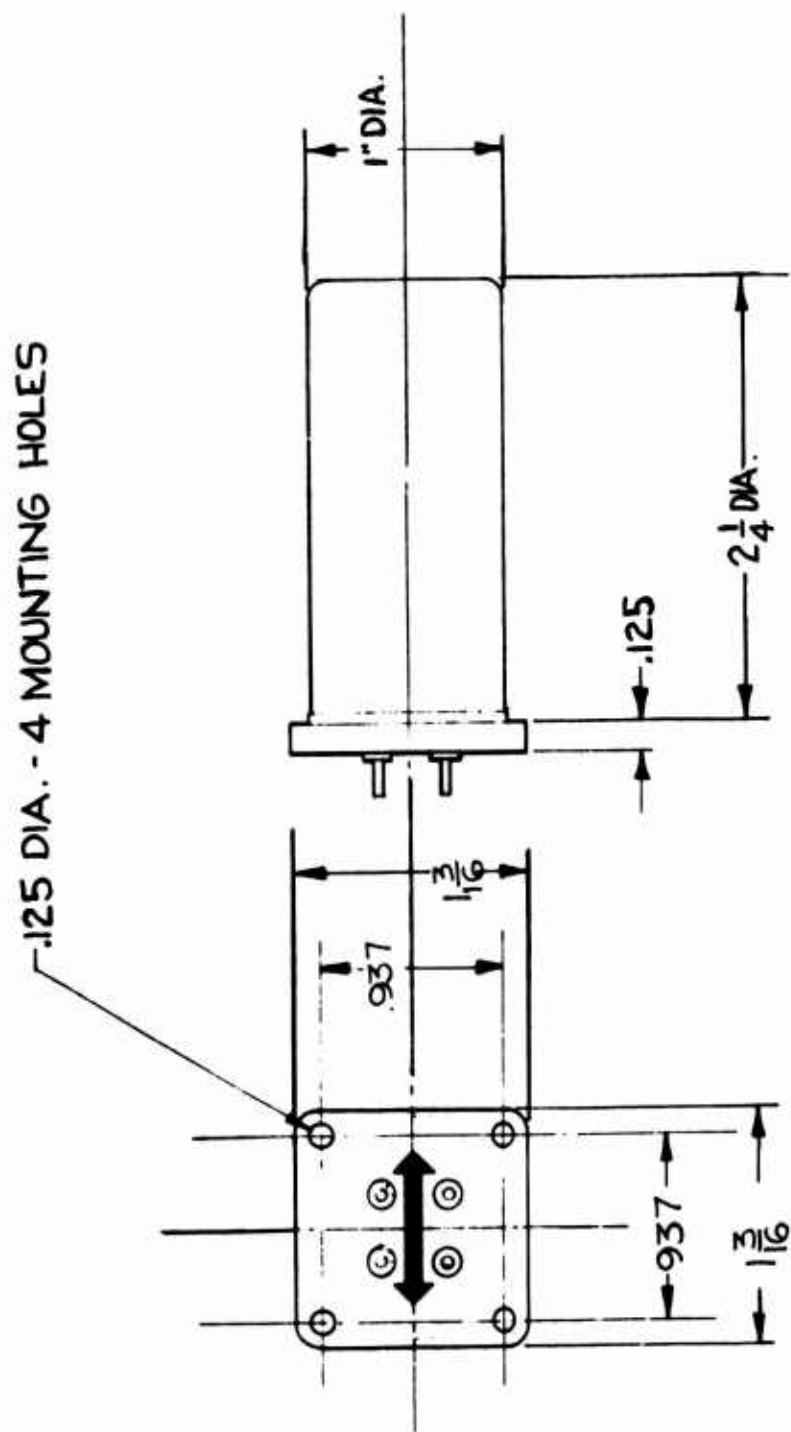

Figure 55. Pitch Sensor.

This device employs a reed-suspended mass immersed in silicone damping fluid in a hermetically sealed package. Strain on the reed is instrumented by semiconductor strain gauges connected in a bridge circuit. The electrical output of this device is summed into the input of the gross weight summing amplifier and the center of gravity indicating meter. The reliability of this device, having no wearing parts, should be excellent under the high vibration environment to be encountered in helicopter applications.

The pitch compensator also employs suitable electronic circuitry to convert the pitch sensor signal to the required trigonometric functions of the pitch angle. These signals are utilized by summing into the corresponding gross weight and center of gravity amplifiers, as shown in Figure 46.

### CONTROL

The control shown in Figure 56 facilitates the application or removal of system power; the momentary application of self-test; the adjustment, application, or removal of lift effect correction; the display of lift balance condition; and the display of sensor control switch position.

The power switch is a "push-on", "push-off" type. The test switch is of the momentary type and removes the sensor signal inputs to the gross weight and center of gravity summing amplifiers and substitutes preset reference voltages. The resultant computation of gross weight and center of gravity is read on the corresponding displays. The deviation seen in each case is compared with an allowable reading error tolerance.

An illuminated amber indicator is provided on the control to annunciate a nonstandard sensor control switch position; that is, if any of the sensor control switches on the calibration/computer package is in other than the position denoted STD, the indicator is illuminated.

Two lift correction adjustment knobs are provided on the front face of the control. Each knob can be manually locked in the selected position and controls a single turn potentiometer. The signals from the potentiometers are used to correct the gross weight and center of gravity readings obtained with the rotors running. The lift correction signals can be applied or removed from the corresponding summing amplifier inputs as required for measurement with the rotors operating or nonoperating.

A specific longitudinal position of the cyclic pitch stick control is indicated by the illumination of the LIFT BAL annunciator. This annunciator enables the pilot to achieve a fixed longitudinal lift vector direction to provide a fixed ratio of lift on the forward and aft struts.

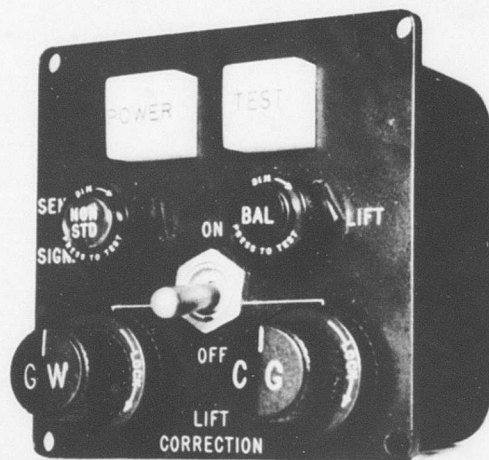

Figure 56. Control Package.

## CARGO HOOK INSTRUMENTATION

The cargo hook or winch instrumentation configuration will depend in each case upon the detail design of the unit to be instrumented. In general, instrumentation of a device of this sort can be accomplished either by measuring an existing structural deflection or by adding a component whose deflection can be measured. The electrical output of the deflection sensor is summed into the gross weight channel of the computer.

Instrumentation of cargo hook loading on the CH-47 is accomplished by substitution of the unit shown on Figure 57 for the existing adapter block which is currently part of the cargo hook assembly. In this unit, the deflection of the lateral beam under load is measured using a deflection sensor of the type shown on Figure 30.

A landing gear oleo compression switch applies the cargo hook or winch load sensor signal to the gross weight summing amplifier when the helicopter is airborne. The switch simultaneously removes all landing gear strut sensor signals and the pitch compensation correction signal from the gross weight summing amplifier. The switch also deactivates the center of gravity display.

## SYSTEM WEIGHT ESTIMATE

This estimate is provided using the application of the recommended system to the CH-47, Chinook, as an example.

TABLE VII  
SYSTEM WEIGHT ESTIMATE

Quantity per Ship Set	Component Description	Estimated Weight	
		per Component (lb.)	per System (lb.)
4	Forward Landing Gear Instrumentation	0.8	3.2
2	Aft Landing Gear Instrumentation	4.0	8.0
1	Display Package	2.0	2.0
1	Calibration/Computer Package	3.0	3.0
1	Control Package	0.7	0.7
1	Pitch Compensator	0.5	0.5
5	Sensor Power Supply	0.5	2.5
	TOTAL Estimated Weight		19.9

NOTE: The above estimated weight is exclusive of cabling weight.

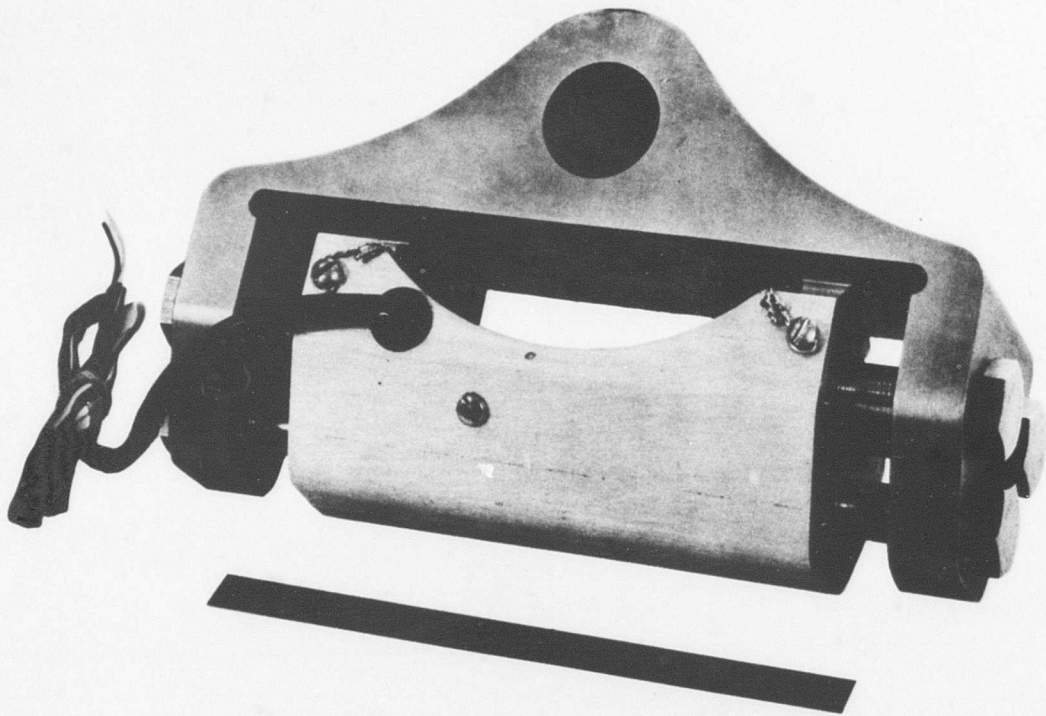

Figure 57. Cargo Hook Instrumentation for CH-47.

## POWER REQUIREMENTS

System electrical power requirements are

AC	115 V, 400 cps, single phase 45 W, power factor 0.86
DC	28 V (lighting power only) 20 W

## ERROR ANALYSIS

Table VIII is an error analysis using the CH-47 integral weight and balance system as an example. Values are given for errors in gross weight and center of gravity in both uncompensated and compensated form. Error sources are listed, and the method of compensation for each is noted. The resultant integral weight and balance system error (RSS) shown for gross weight and center of gravity simultaneously includes maximum values for each error source listed and therefore can be assumed to be worst-case error values. Naturally, the magnitude of these errors will decrease for operation of the integral weight and balance system under more nearly nominal conditions.

### PROGRAM PLAN FOR ADAPTATION OF INTEGRAL WEIGHT AND BALANCE SYSTEM TO ANY ARMY CARGO HELICOPTER

The adaptation of the recommended integral weight and balance system to any Army cargo helicopter mainly concerns the application of the standard deflection sensor to the structures to be instrumented. Each landing gear strut and cargo hook or cable hoist is instrumented by using the techniques previously described in this report. The general procedure for application of an integral weight and balance system to a helicopter is shown in Table IX. A typical program plan defining the integral weight and balance system application tasks, their sequence in the program, and their duration is shown in Table X.

TABLE VIII  
ANALYSIS OF INTEGRAL WEIGHT AND BALANCE SYSTEM ERROR  
(USING CH-47 INTEGRAL WEIGHT AND BALANCE SYSTEM AS EXAMPLE)

Error Sources	GW Error Uncompensated	GW Error After Compensation	CG Position Error Uncompensated	Residual CG Position Error (in.) After Compensation	Method of Compensation
Lift effect at flight-operating RPM Fixed collective pitch	20% (approx.)	0	14.2 in.	1.3 in. (max.)	GW & CG lift correction potentiometers and fixed longitudinal cyclic control position ( $\pm 1/8$ in.)
Density altitude lift variation	1/2%/1000 ft. (approx.)	0.05%/1000 ft. 0.3%/6000 ft.	0.2 in./1000 ft. density alt.	0.02 in./1000 ft. density alt.	Pressure altitude & temp. sensors or manual adj. of correction inputs
Variation of GW & CG measurement with 10° terrain slope, assuming nominal CG height	1.5%	0.25%	14.6 in.	0.1 in. (max.)	Pendulous pitch angle sensor and signal conditioning circuitry
Cyclic vibration (> 3 cps)	Poor display readability	0	Poor display readability	0	Damping
Variation of CG height $\pm 3$ " from nominal on terrain slope of 10°	0	0	$\pm 1/2$ in. change in fuselage station	0.5 in.	None
Strut loading in directions non-perpendicular to plane of ground (excluding terrain pitch slope)	Not applicable	0.5% (max.)	Not applicable	0.3 in. (max.)	Fixed physical relationship of instrumentation to strut
System Error (-54°C to +71°C) offset					
Sensors scale factor (6 sensors) linearity	Not applicable	.51%	Not applicable	0.5 in. (max.)	Integral temperature compensation elements
Computer (drift) including power supplies	Not applicable	0.1%	Not applicable	0.1 in. (max.)	Balanced thermoelectrical component design
Indicator gross weight servo CG meter mech. (lin. & repeat)	0	0	0.5%	0.5 in. (max.)	Integral temperature compensation elements
Modulus of elasticity of struts	3.5%	0.2%	3.5 in.	0.2 in. (max.)	Electrical measurement of strut temperature
RESULTANT IWBS ERROR (RSS)	--	Gross Weight 0.84% (max.)	--	CG 1.62 in. (max.)	--

TABLE IX  
GENERAL PROCEDURE FOR APPLICATION OF  
INTEGRAL WEIGHT AND BALANCE SYSTEM TO ANY ARMY CARGO HELICOPTER

LOAD SENSOR APPLICATION	PITCH SENSOR	CALIBRATION/ COMPUTER PACKAGE	CONTROL PACKAGE	GROSS WEIGHT & CENTER OF GRAVITY DISPLAY
<p>Compute geometric relationship for load sensor design adaptation to landing gear struts.</p>	<p>Universal Design — no modification required</p>	<p>Modify package front panel to accommodate strut load sensor switches</p>	<p>Universal Design — no modification required</p>	<p>Scale mechanical and electrical components in gross weight and center of gravity displays to readout range required</p>
<p>Design prototype instrumentation hardware and prove in landing gear test lab for:</p> <ul style="list-style-type: none"> <li>— Vertical load sensitivity</li> <li>— Nonvertical load insensitivity</li> <li>— Drop test (permanence)</li> </ul>		<p>Adapt plug-in calibration potentiometer and scaling resistor module to accommodate number of strut load sensor signal inputs employed</p>		
<p>Finalize instrumentation design, including electrical cabling</p>				

TABLE X  
 PROGRAM PLAN FOR APPLICATION OF INTEGRAL WEIGHT AND BALANCE SYSTEM  
 TO ANY ARMY CARGO HELICOPTER (TYPICAL)

T A S K	MONTHS											
	1	2	3	4	5	6	7	8	9	10	11	12
Requirement Established and Performance Spec. Prepared	△											
RFP or RFQ Issued	△											
Contractor's Proposal Prepared and Submitted	△	△										
Proposal Evaluated	△	△										
Contract Negotiated & Awarded	△	△										
Contractor's Program Plan:												
System Application Design				△								
System Electronics												
Design Analysis				△	△							
Final Design & Release				△	△							
Strut Instrumentation												
Design Analysis				△	△							
Test Verification				△	△							
Final Design & Release				△	△							
Mfg. Tooling Design & Fabrication				△	△							
AGE Design & Fabrication				△	△							
First Production Article Fab. & Del. Release for Production				△	△							
Qual Test Program												
Production Deliveries												
First Production Article Test Program												
System Installation												
Field Installation, or Delivery to OEM												

Unclassified

Security Classification

DOCUMENT CONTROL DATA - R & D		
<i>(Security classification of title, body of abstract and indexing annotation must be entered when the overall report is classified)</i>		
1. ORIGINATING ACTIVITY (Corporate author) Instrumentation & Control Operations National Water Lift Co. Division 3000 Kraft Ave., S.E., Grand Rapids, Mich. 49501		2a. REPORT SECURITY CLASSIFICATION Unclassified
		2b. GROUP
3. REPORT TITLE Design Analysis of Integral Weight and Balance System for Army Cargo Helicopters		
4. DESCRIPTIVE NOTES (Type of report and inclusive dates) Final Report		
5. AUTHOR(S) (First name, middle initial, last name) Stuart L. Varner		
6. REPORT DATE August 1967	7a. TOTAL NO. OF PAGES 109	7b. NO. OF REFS
8a. CONTRACT OR GRANT NO. DA44-177-AMC-451(T)	8b. ORIGINATOR'S REPORT NUMBER(S) E-12064	
8c. PROJECT NO.	8d. OTHER REPORT NO(S) (Any other numbers that may be assigned this report) USAAVLABS Report 67-50	
10. DISTRIBUTION STATEMENT Distribution of this document is unlimited.		
11. SUPPLEMENTARY NOTES	12. SPONSORING MILITARY ACTIVITY Department of the Army U.S. Army Aviation Materiel Laboratories Fort Eustis, Virginia 23604	
13. ABSTRACT This study covered an analysis of helicopter operational usage affecting the design, installation, and operation of an integral weight and balance system for Army cargo helicopters currently in existence with those yet in the planning stage. An analysis of existing integral weight and balance systems and the applicability to helicopter usage was also performed. A recommended general system configuration is discussed as the outcome of the previously accomplished analysis. Problems involving accurate measurement of the gross weight and center of gravity with rotor(s) in operation are discussed with the solution. The application of an integral weight and balance system to Army cargo helicopters appears to be entirely feasible.		

DD FORM 1473  
1 NOV 66

REPLACES DD FORM 1473, 1 JAN 64, WHICH IS OBSOLETE FOR ARMY USE.

Unclassified

Security Classification

Unclassified

Security Classification

14. KEY WORDS	LINK A		LINK B		LINK C	
	ROLE	WT	ROLE	WT	ROLE	WT
Integral Weight and Balance System (IWBS) On-Board Weight and Balance System Gross Weight Center of Gravity Rotor Lift Effect Density Altitude Terrain Slope Landing Gear Load Instrumentation Pitch Angle Instrumentation Cargo Hook Instrumentation Weight and Center of Gravity Display Deflection Sensing Strain Gage Calibration Computer Summing Amplifier Servo Amplifier Side Load Force Vertical Load Force Drag Load Force Scrub Turn Force Oleo Strut						

Unclassified

Security Classification

6833-67