

AD 664927

(1)

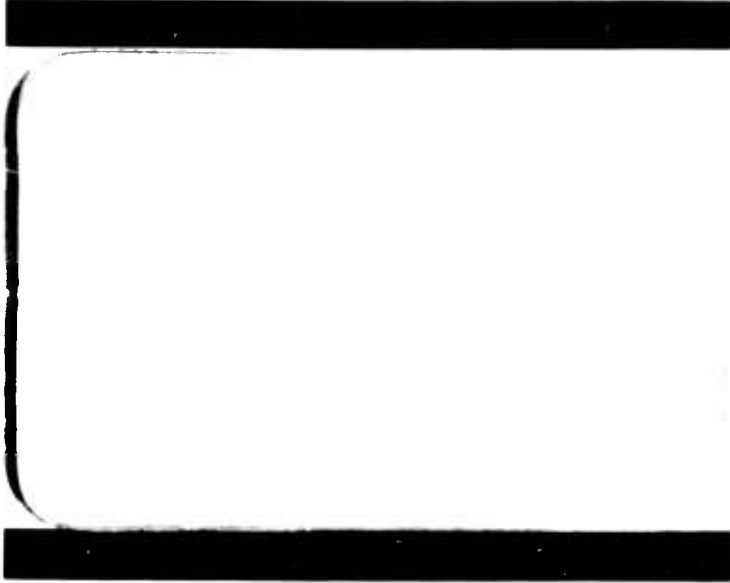

Some or all of this document
is unlimited.



GENERAL DYNAMICS
Convair Division

DDC
RECEIVED
FEB 14 1968
C



A2136-1 (REV. 5-65)

**Best
Available
Copy**

ANALYSIS
PREPARED BY
CHECKED BY
REVISED BY

CONVAIR
A DIVISION OF GENERAL DYNAMICS CORPORATION
SAN DIEGO

PAGE 1
REPORT NO. ZU-7-069
MODEL 7
DATE 16 Oct. 1956

FOREWORD

The solution for the fluid forces on an oscillating cylindrical tank as given in Reference (1) are for lateral translatory motions alone. The present report extends the solution to include tank rotations about a transverse axis.

ANALYSIS
PREPARED BY
CHECKED BY
REVISED BY

CONVAIR
A DIVISION OF GENERAL DYNAMICS CORPORATION
SAN DIEGO

PAGE -11
REPORT NO. ZU-7-069
MODEL 7
DATE 16 Oct. 1956

TABLE OF CONTENTS

	<u>Page</u>
FOREWORD.....	1
TABLE OF CONTENTS.....	11
SUMMARY.....	iii
Introduction.....	1
Nomenclature.....	2
Analysis.....	4
Conclusions.....	18
REFERENCES.....	19
APPENDIX.....	20
List of Symbols.....	21

ANALYSIS
PREPARED BY
CHECKED BY
REVISED BY

C O N V A I R
A DIVISION OF GENERAL DYNAMICS CORPORATION
SAN DIEGO

PAGE 111
REPORT NO. ZU-7-069
MODEL 7
DATE 16 Oct. 1956

SUMMARY

The solution to the problem of forced oscillations of a fluid in a cylindrical tank undergoing translations and rotations along and about a transverse axis through its base is found by an extension of a previous solution for translations only (Reference 1). Through the use of the LaPlace transform, the results are written in the form of transfer functions giving the transverse force and moment about the tank bottom for arbitrary planar motions of the tank. Only the fundamental mode of fluid sloshing is considered in presenting the final results and only small disturbances are admitted.

Solutions are presented both for a tank moving in a fixed acceleration field (as on earth) and in an acceleration field carried with the tank (as in a freely falling missile).

A mechanical analogy of a fixed mass plus a pendulous mass is found to duplicate the forces and moments identically in both the fixed and carried acceleration field cases.

In an appendix, the equations of motion are developed for a missile containing a large fluid tank through the use of the hydrodynamic transfer function. The resulting equations are shown to coincide with those which would be obtained through the use of the mechanical analogy.

ANALYSED
PREPARED BY
CHECKED BY
REVISED BY

C O N V A I R
A DIVISION OF GENERAL DYNAMICS CORPORATION
SAN DIEGO

PAGE 1
REPORT NO. ZU-7-069
MODEL 7
DATE 16 Oct. 1956

INTRODUCTION

A cylindrical tank, partially filled with a liquid, is considered to translate and rotate in an arbitrary manner along and about a transverse axis through its base.

The object of this report is to present a complete hydrodynamic solution giving the forces and moments on the tank as functions of the tank motions. For applications to a missile stability study these results are given in the form of motion-to-force transfer functions and, alternately, in the form of a mechanical analogy.

NOMENCLATURE

A_1	} - dimensionless parameters defined in equations (9) and (10)	
B_2		
C_1		
D_1		
F	- force in x direction	- pounds
J	- Bessel function of first kind	
K_n	- tank parameter, $\xi_n h/a$	
M	- total fluid mass	- slugs
m	- hydrodynamic moment on tank	- lb.ft.
P	- hydrodynamic pressure	- psf
S	- area	- feet ²
T	- kinetic energy	- lb.feet
U	- potential energy	- lb.feet
a	- tank radius	- feet
g	- acceleration of gravity	- fps ²
h	- depth of fluid	- feet
q	- total fluid particle velocity = $\sqrt{u^2 + v^2 + w^2}$	- fps
r	- radial coordinate	- feet
s	- La Place variable	- sec. ⁻¹
t	- time	- sec.
u, v, w	- fluid velocities in coordinate directions x, y, z respectively	- fps
x, y, z	- cartesian coordinates	
r, θ, z	- polar coordinates	
α_T	- acceleration in Z (axial) direction	- fps ²
β_n	- coefficient of fluid mode	- feet ² /sec.

ANALYSIS
PREPARED BY
CHECKED BY
REVIEWED BY

C O N V A I R
A DIVISION OF GENERAL DYNAMICS CORPORATION
SAN DIEGO

PAGE 3
REPORT NO. ZU-7-069
MODEL 7
DATE 16 Oct. 1956

NOMENCLATURE (CONTINUED)

- ξ_n - root of $J_i' = 0$
- θ - rotation of tank about its base
- ρ - fluid density - slugs/ft³
- ω_n - fluid mode natural frequency - sec.⁻¹
- Ω_n - defined attenuating frequency - sec.⁻¹
- ϕ - fluid velocity potential : $\vec{q} = -\text{Grad } \phi$ - feet²/sec.
- γ_p - angle of pendulum with tank axis
- Γ_p - angle of pendulum with vertical (= $\gamma - \theta$)
- γ_F - analogous fluid "angle" defined by equation (15)
- Γ_F - analogous fluid "angle" defined by equation (18)

ANALYSIS

Reference (1) presents the equations of motion and boundary conditions for a perfect fluid in a cylindrical tank having a vertical axis and undergoing an arbitrary lateral translation. Choosing a cylindrical coordinate system as in Figure 1, the problem is shown to reduce to that of finding the velocity potential $\phi(r, \phi, z)$ satisfying Laplace's equation and subject to the boundary conditions that

- i) at the tank walls the fluid particle velocity must equal that of the wall and that
- ii) at the free surface

$$\frac{\partial^2 \phi}{\partial t^2} + \alpha_r \frac{\partial \phi}{\partial z} = 0$$

where α_r is the acceleration in the Z direction.

For the case of the tank which also undergoes a rotation θ about a transverse axis through its base, the complete mathematical statement of the problem is contained in the following equations:

$$\frac{\partial^2 \phi}{\partial r^2} + \frac{1}{r} \frac{\partial \phi}{\partial r} + \frac{1}{r^2} \frac{\partial^2 \phi}{\partial \phi^2} + \frac{\partial^2 \phi}{\partial z^2} = 0 \quad (1)$$

$$-u \Big|_{r=a} = \frac{\partial \phi}{\partial r} \Big|_{r=a} = -(\dot{\theta} z + \dot{x}) \cos \phi \quad (2)$$

$$-w \Big|_{z=0} = \frac{\partial \phi}{\partial z} \Big|_{z=0} = r \dot{\theta} \cos \phi \quad (3)$$

$$\left(\frac{\partial^2 \phi}{\partial t^2} + \alpha_r \frac{\partial \phi}{\partial z} \right)_{z=h} = 0 \quad (4)$$

In equation (4), α_r is the acceleration in the carried Z direction.

ANALYSIS
PREPARED BY
CHECKED BY
REVISED BY

CONVAIR
A DIVISION OF GENERAL STRINGS CORPORATION
SAN DIEGO

PAGE 5
REPORT NO. ZU-7-069
MODEL 7
DATE 16 Oct. 1956

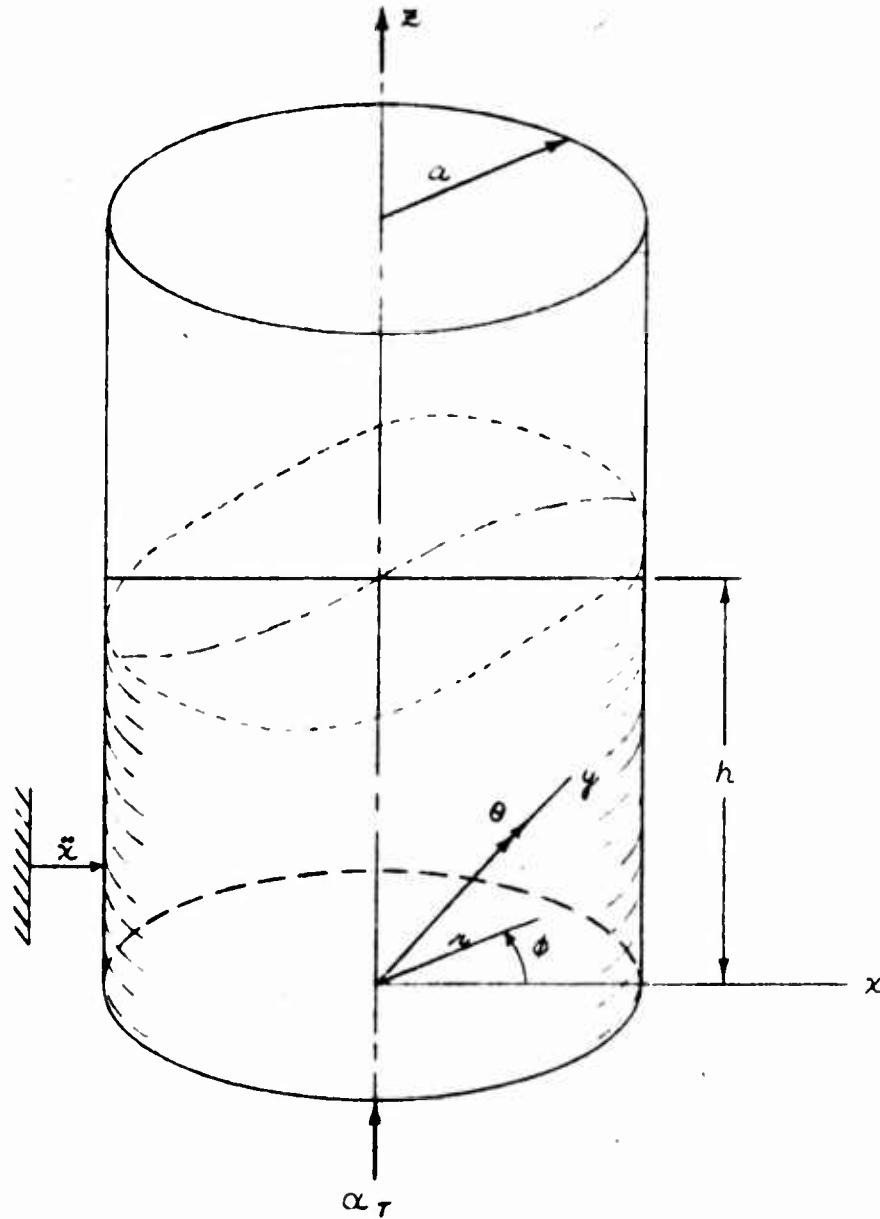

FIGURE 1

PROBLEM COORDINATES & DIMENSIONS

Following the lead of Reference (1) a solution is sought in the form of a series of products of Bessel and Hyperbolic functions. By a trial process, the following potential function is found to satisfy equations (1), (2) and (3).

$$\phi = -(\dot{\theta}z + \dot{x})r \cos \phi + \sum_n \beta_n J_1\left(\frac{\xi_n r}{a}\right) \cos \phi \frac{\cosh \frac{\xi_n z}{a}}{\cosh \frac{\xi_n h}{a}} + \sum_n \frac{a}{\xi_n} \frac{4a J_1\left(\frac{\xi_n r}{a}\right)}{(\xi_n^2 - 1) J_1(\xi_n)} \dot{\theta} \cos \phi \frac{\sinh \frac{\xi_n (z-h)}{a}}{\cosh \frac{\xi_n h}{a}} \quad (5)$$

Here J_1 is the Bessel function of the first kind of order one, and the ξ_n are the roots of $J_1' = 0$. In satisfying the boundary conditions represented by equation (3), use has been made of the equality

$$2r = \sum_{n=1}^{\infty} \frac{4a J_1\left(\frac{\xi_n r}{a}\right)}{(\xi_n^2 - 1) J_1(\xi_n)}$$

The undetermined coefficients β_n in equation (5) are found by satisfying boundary condition (4). Substitution of equation (5) into (4) leads to

$$-s^3(\bar{\theta}h + \bar{x})r + \sum_n \bar{\beta}_n J_1\left(\frac{\xi_n r}{a}\right) (s^2 + \omega_n^2) - \alpha_T s \bar{\theta} r + \alpha_T s \bar{\theta} \sum_n \frac{4a J_1\left(\frac{\xi_n r}{a}\right)}{(\xi_n^2 - 1) J_1(\xi_n) \cosh \frac{\xi_n h}{a}} = 0$$

where

$$\omega_n^2 = \frac{\alpha_T \xi_n}{a} \tanh \frac{\xi_n h}{a}$$

Here the time derivatives have been written in operational form through the use of the Laplace transform. "s" is the Laplace variable and the "barred" quantities are the transformed functions of "s".

This last equation is now multiplied through by r and $J_1\left(\frac{\xi_m r}{a}\right)$ and then integrated term by term between the limits of zero and "a". The following integral properties are used in establishing the result:

$$\int_0^a r^2 J_1\left(\frac{\xi_n r}{a}\right) dr = \frac{a^3}{\xi_n^2} J_1(\xi_n)$$

$$\int_0^a r J_1\left(\frac{\xi_n r}{a}\right) \cdot J_1\left(\frac{\xi_m r}{a}\right) dr = \begin{cases} 0 & m \neq n \\ \frac{a^2}{2} \frac{(\xi_n^2 - 1)}{\xi_n^2} J_1^2(\xi_n) & m = n \end{cases}$$

where $J_1'(\xi_n) = 0$

Following the procedure as outlined, one obtains

$$-a s \left[s^2 \bar{x} + \bar{\theta} h \left(s^2 + \frac{\alpha_T}{h} - \frac{2\alpha_T}{h \cosh \frac{\xi_n h}{a}} \right) \right]$$

$$+ \bar{\beta}_n (s^2 + \omega_n^2) \frac{(\xi_n^2 - 1)}{2} J_1(\xi_n) = 0$$

Solving,

$$\bar{\beta}_n = s \frac{2a [s^2 \bar{x} + \bar{\theta} h (s^2 + \omega_n^2)]}{(s^2 + \omega_n^2) (\xi_n^2 - 1) J_1(\xi_n)} \quad (6)$$

where $\omega_n^2 = \frac{\alpha_T}{h} \left(1 - \frac{2}{\cosh \frac{\xi_n h}{a}} \right)$

Equation (6), when substituted back into equation (5) (transformed) yields the desired potential function

$$\bar{\phi} = -s(\bar{\theta} z + \bar{x}) r \cos \phi + 2as \sum_n \frac{s^2 \bar{x} + \bar{\theta} h (s^2 + \omega_n^2)}{(s^2 + \omega_n^2) (\xi_n^2 - 1) J_1(\xi_n)} J_1\left(\frac{\xi_n r}{a}\right) \cos \phi \frac{\cosh \frac{\xi_n z}{a}}{\cosh \frac{\xi_n h}{a}}$$

$$+ s \bar{\theta} \sum_n \frac{a}{\xi_n} \frac{4a J_1\left(\frac{\xi_n r}{a}\right)}{(\xi_n^2 - 1) J_1(\xi_n)} \cos \phi \frac{\sinh \frac{\xi_n (z-h)}{a}}{\cosh \frac{\xi_n h}{a}} \quad (7)$$

A well-known property of the velocity potential is that it is related to the disturbance (dynamic) pressure by*

$$p_d = \rho \frac{\partial \phi}{\partial t}$$

Therefore, from equation (7) the transformed pressure disturbance is

$$\begin{aligned} \frac{\bar{p}_d}{\rho} = & -\alpha^2 (\bar{\theta} z + \bar{x}) \alpha \cos \phi + 2\alpha \alpha^2 \sum_n \frac{\alpha^2 \bar{x} + \bar{\theta} h (\alpha^2 + \Omega_n^2)}{(\alpha^2 + \Omega_n^2) (\xi_n^2 - 1) J_1(\xi_n)} J_1\left(\frac{\xi_n r}{a}\right) \cos \phi \frac{\cosh \frac{\xi_n z}{a}}{\cosh \frac{\xi_n h}{a}} \\ & + \alpha^2 \bar{\theta} \sum_n \frac{a}{\xi_n} \frac{4\alpha J_1\left(\frac{\xi_n r}{a}\right)}{(\xi_n^2 - 1) J_1(\xi_n)} \cos \phi \frac{\sinh \frac{\xi_n (z-h)}{a}}{\cosh \frac{\xi_n h}{a}} \end{aligned} \quad (8)$$

Forces in X direction

The dynamic wall pressure is given by equation (8) with $r = a$. The lateral force is then obtained by the integral

$$F = \rho \int_0^h \int_0^{2\pi} \left. \frac{\partial \phi}{\partial t} \right|_{r=a} a \cos \phi \, d\phi \, dz$$

The integration when carried out leads to

$$\begin{aligned} \bar{F}(z) = & -\alpha^2 \bar{x} M - \alpha^2 \bar{\theta} \left\{ M \frac{h}{2} + 4Mh \sum_n \left(\frac{a}{\xi_n h} \right)^2 \frac{\cosh \frac{\xi_n h}{a} - 1}{(\xi_n^2 - 1) \cosh \frac{\xi_n h}{a}} \right\} \\ & + 2M \sum_n \frac{z}{\xi_n h} \frac{[\alpha^2 \bar{x} + \alpha^2 h \bar{\theta} (\alpha^2 + \Omega_n^2)]}{(\xi_n^2 - 1) (\alpha^2 + \Omega_n^2)} \tanh \frac{\xi_n h}{a} \end{aligned}$$

where $M = \pi \rho a^2 h$

* For equilibrium, the Euler equation gives $\frac{D\vec{\phi}}{Dt} = \frac{1}{\rho} \text{Grad } P$ and hence $\vec{\phi} = -\frac{1}{\rho} \text{Grad} \int_0^t P dt$ where $\int_0^t P dt$ is the impulse per unit area applied to the fluid. By definition $\vec{q} = -\text{Grad } \phi$. Hence, $\rho \vec{\phi} = \int_0^t P dt = \text{impulse per unit area}$. Then the force per unit area (pressure) $= \rho \frac{d\phi}{dt}$

Within each of the summations appearing in the above expression the terms for n greater than unity are negligibly small at all exciting frequencies excepting those near the higher fluid mode resonances. The relative importance of the higher mode terms may be judged by the succession of denominator factors ($\xi_n^2 - 1$). The first few of these are:

$$\begin{aligned}\xi_1^2 - 1 &= 2.386 \\ \xi_2^2 - 1 &= 27.46 \\ \xi_3^2 - 1 &= 71.85 \\ \xi_4^2 - 1 &= 136.01\end{aligned}$$

Consequently, it is satisfactory to omit the higher mode terms for most applications. If this step is taken one may write

$$F(s) = -s^2 \bar{x} M - s^2 \bar{\theta} h \left(\frac{1}{2} + C_1 \right) + s^2 M A_1 \left[\frac{s^2 \bar{x} + \bar{\theta} h (s^2 + \Omega_1^2)}{s^2 + \omega_1^2} \right] \quad (9)$$

where $A_1 = \frac{2}{K_1} \frac{\tanh K_1}{(\xi_1^2 - 1)}$

$$C_1 = \frac{4}{K_1^2} \frac{\cosh K_1 - 1}{(\xi_1^2 - 1) \cosh K_1}$$

$$K_1 = \frac{\xi_1 h}{a}$$

$$\xi_1 = 1.84$$

Moments about the Tank Base

The moments about the tank base, positive in the sense of positive θ (Figure 1), due to dynamic fluid pressures are given by

$$M = \rho \int_0^h \int_0^{2\pi} \frac{\partial \phi}{\partial t} \Big|_{r=a} z a \cos \phi \, d\phi \, dz + \rho \int_0^a \int_0^{2\pi} \frac{\partial \phi}{\partial t} \Big|_{z=0} r^2 \cos \phi \, d\phi \, dr$$

If these integrals are evaluated and the results are again restricted to the fundamental mode terms, there is obtained

$$\begin{aligned} \bar{m}(\omega) = & -\omega^2 \bar{x} M h \left\{ \frac{1}{2} + \frac{\omega^2}{4h^2} \right\} - \omega^2 \bar{\theta} M h^2 \left\{ \frac{1}{3} + D_1 \right\} \\ & + \omega^2 M h B_2 \frac{[\omega^2 \bar{x} + h \bar{\theta} (\omega^2 + \Omega_1^2)]}{(\omega^2 + \omega_1^2)} \end{aligned} \quad (10)$$

where* $B_2 = 2 \frac{1}{K_1^2} \frac{2 + K_1 \sinh K_1 - \cosh K_1}{(\xi_1^2 - 1) \cosh K_1}$

$$D_1 = 4 \frac{1}{K_1^3} \frac{2 \sinh K_1 - K_1}{(\xi_1^2 - 1) \cosh K_1}$$

Equations (9) and (10) comprise the major result inasmuch as they provide the desired force and moment transfer functions.

It is worth noting that the integral of the dynamic pressure normal to the tank base is zero. Thus, the sloshing motion has no influence on forces in the Z (longitudinal) direction and the inertial properties in this direction remain those of a rigid mass. The integral of the uniform hydrostatic head h over the base gives the force in the Z direction as

$$F_Z = -M \alpha_T \quad (11)$$

*For the reader who may puzzle over the choice of notations here it is noted that the symbols were adopted to conform to those of Reference 1.

Static Fluid Forces

While equations (9), (10) and (11) provide the tank forces due to tank accelerations there also may be forces due to static displacements of the tank. Two cases must be distinguished:

- a) the acceleration field is carried with (rotates with) the tank, being always in the Z direction. This case arises in the freely falling missile whose acceleration is due to rocket motor thrusts directed always in the longitudinal (z) direction. In this case the fluid level tends always to follow the tank motion and hence no static forces or moments are produced.
- b) the acceleration field is fixed. This case arises with the tank oscillating in a test stand on the ground. The static tipping of the tank produces a disturbance pressure ($\rho g r \theta \cos \phi$) throughout the tank. Integrated over the tank surface this disturbance pressure produces a transverse force in the positive X direction and a positive moment. The transverse force is exactly cancelled by the horizontal component of the main hydrostatic base pressure ($\rho g h$) so that there results finally

$$\left. \begin{aligned} F_{STATIC} &= 0 \\ M_{STATIC} &= M g h \left(\frac{a^2}{4h^2} + \frac{1}{2} \right) \theta \end{aligned} \right\} \quad (12)$$

Equations (12) must be added to (9) and (10) for the tank moving in a fixed acceleration field.

Mechanical Analogy

In preparation for the derivation of a mechanical analogy the following rearrangement is made of the hydrodynamic solution. First, the results are rewritten here:

$$\bar{F} = -s^2 \bar{x} M - s^2 \bar{\theta} M h \left(\frac{1}{2} + C_1 \right) + s^2 M A_1 \frac{s^2 \bar{x} + h \bar{\theta} (s^2 + \Omega^2)}{s^2 + \omega^2} \quad (13)$$

$$\begin{aligned} \bar{M} = & -s^2 \bar{x} M h \left(\frac{1}{2} + \frac{a^2}{4h^2} \right) - s^2 \bar{\theta} M h^2 \left(\frac{1}{3} + D_1 \right) \\ & + s^2 M h B_2 \frac{s^2 \bar{x} + h \bar{\theta} (s^2 + \Omega^2)}{s^2 + \omega^2} \left[+ M g h \left(\frac{a^2}{4h^2} + \frac{1}{2} \right) \bar{\theta} \right] \end{aligned} \quad (14)$$

Here we have written within the dotted box those additional terms peculiar to the fixed acceleration field problem.

Now let

$$\bar{\delta}_F = -\frac{1}{L_p} \frac{s^2 \bar{x} + h\bar{\theta} (s^2 + \Omega^2)}{s^2 + \omega^2} \quad (15)$$

where $L_p = a_T / \omega^2$. Thus, equations (13) and (14) become

$$\bar{F} = -s^2 \bar{x} M - s^2 \bar{\theta} M h \left(\frac{1}{2} + C_1 \right) - s^2 M A_1 L_p \bar{\delta}_F \quad (16)$$

$$\begin{aligned} \bar{m} = & -s^2 \bar{x} M h \left(\frac{1}{2} + \frac{a^2}{4h^2} \right) - s^2 \bar{\theta} M h^2 \left(\frac{1}{3} + D_1 \right) \\ & - s^2 M h B_2 L_p \bar{\delta}_F \left[+ M_2 h \left(\frac{a^2}{4h^2} + \frac{1}{2} \right) \bar{\theta} \right] \end{aligned} \quad (17)$$

Equation (15) may be written

$$(s^2 + \omega^2) \bar{\delta}_F = -\frac{1}{L_p} [s^2 \bar{x} + h\bar{\theta} (s^2 + \Omega^2)]$$

Making the further substitution

$$\bar{F}_F = \bar{\delta}_F - \frac{\Omega^2}{\omega^2} \bar{\theta} \quad (18)$$

this becomes

$$(s^2 + \omega^2) \bar{F}_F = -\frac{1}{L_p} \left[s^2 \bar{x} + s^2 \bar{\theta} h \left(1 - \frac{\Omega^2}{\omega^2} \right) \right] \quad (19)$$

If now equations (18) and (19) are used to eliminate $\bar{\delta}_F$ from (16) and (17), one obtains

$$\bar{F} = -s^2 \bar{x} M (1 - A_1) - s^2 \bar{\theta} M h \left(\frac{1}{2} + \frac{a^2}{4h^2} - B_2 \right) + M A_1 a_T \bar{F}_F \quad (20)^*$$

*In writing equation (20) use has been made of the identity $\frac{1}{2} + C_1 - A_1 \equiv \frac{1}{2} + \frac{a^2}{4h^2} - B_2$.

$$\bar{m} = - \mathcal{A}^2 \bar{x} M h \left(\frac{1}{2} + \frac{a^2}{4h^2} - B_2 \right) - \mathcal{A}^2 \bar{\theta} M h^2 \left(\frac{1}{3} + D_1 - B_2 \right) + M h B_2 \alpha_T \bar{F}_F \left[+ M g h \left(\frac{a^2}{4h^2} + \frac{1}{2} \right) \right] \quad (21)$$

Equations (20) and (21) express the results in the desired form, giving the forces as functions of the tank motion plus a fluid "angle" whose equation of motion is given by equation (19).

We now proceed to determine the equations of motion for the mechanical system of Fig. 2.

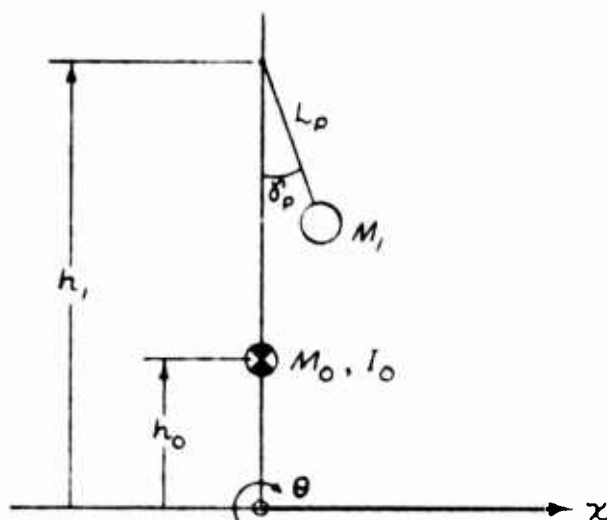

Fig. 2 - ANALOGOUS MECHANICAL SYSTEM

As in the hydrodynamic problem, two acceleration field cases are possible: a fixed field and a carried field. While the equations of motion are similar in these cases, their final rearrangements to bring them into the form of equations (19), (20) and (21) differ, and hence we derive them separately for convenience.

"Carried Field" Pendulum System

The kinetic and potential energies for the system of Fig. 2 when displaced in an acceleration field carried with the axes are

$$T = \frac{1}{2} M_0 (\dot{x} + h_0 \dot{\theta})^2 + \frac{1}{2} M_1 [\dot{x} + (h_1 - L_p) \dot{\theta} + L_p \dot{\delta}_p]^2 + \frac{1}{2} I_0 \dot{\theta}^2$$

$$U = \frac{1}{2} M_1 \alpha_T L_p \delta_p^2$$

Using LaGrange's equation, the forces and moments and the equation of motion in δ_p are

$$F = -(M_0 + M_1) \ddot{x} - [M_0 h_0 + M_1 (h_1 - L_p)] \ddot{\theta} - M_1 L_p \ddot{\delta}_p \quad (22)$$

$$\begin{aligned} \mathcal{M} = & - [M_0 h_0 + M_1 (h_1 - L_p)] \ddot{x} - [M_0 h_0^2 + I_0 + M_1 (h_1 - L_p)^2] \ddot{\theta} \\ & + M_1 (h_1 - L_p) L_p \ddot{\delta}_p \end{aligned} \quad (23)$$

$$\ddot{\delta}_p + \omega^2 \delta_p = - \frac{1}{L_p} [\ddot{x} + (h_1 - L_p) \ddot{\theta}] \quad (24)$$

$$\text{where } \omega^2 = \frac{\alpha_T}{L_p}$$

Equation (24) is already identical in form with the corresponding hydrodynamic equation (19). If it is used to substitute into equations (22) and (23) for $\ddot{\delta}_p$ one obtains (transformed)

$$F = - \alpha^2 \ddot{x} M_0 - \alpha^2 \ddot{\theta} M_0 h_0 + M_1 \alpha_T \delta_p \quad (25)$$

$$\mathcal{M} = - \alpha^2 \ddot{x} M_0 h_0 - \alpha^2 \ddot{\theta} (M_0 h_0^2 + I_0) + M_1 (h_1 - L_p) \alpha_T \delta_p \quad (26)$$

These equations are identical in form with equations (20) and (21) of the hydrodynamic solution (less the terms in dotted box for a fixed field). Comparing term by term, the correspondences listed in Table 1 are found.

TABLE 1

ANALOGOUS MECHANICAL SYSTEM PARAMETERS
CARRIED ACCELERATION FIELD

<u>MECHANICAL</u>	<u>HYDRODYNAMIC</u>
M_0	$M(1-A_1)$
h_0	$h \left(\frac{1}{2} + \frac{z^2}{4h^2} - B_2 \right) / (1-A_1)$
M_1	MA_1
$M_0 h_0^2 + I_0$	$Mh^2 \left(\frac{1}{3} + D_1 - B_2 \right)$
$h_1 - L_p$	$h B_2 / A_1$
L_p	a_T / ω^2
* $h_1 - L_p$	$h \left(1 - \Omega^2 / \omega^2 \right)$

* this relationship is already satisfied identically by a preceding equality, i.e., we can show that

$$B_2 / A_1 \equiv 1 - \Omega^2 / \omega^2$$

The analogous mechanical system is thus defined. Equations (24), (25) and (26) are its solution.

"Fixed Field" Pendulum System

The kinetic and potential energies are

$$T = \frac{1}{2} M_0 (\dot{x} + h_0 \dot{\theta})^2 + \frac{1}{2} M_1 [\dot{x} + (h_1 - L_p) \dot{\theta} + L_p \dot{\theta}_p]^2 + \frac{1}{2} I_0 \dot{\theta}^2$$

$$U = -\frac{1}{2} M_0 g h_0 \theta^2 - \frac{1}{2} M_1 g [h_1 \theta^2 - L_p (\delta_p - \theta)^2]$$

Using LaGrange's equation the forces, moments and equation of swinging are found to be

$$F = - (M_0 + M_1) \ddot{x} - [M_0 h_0 + M_1 (h_1 - L_p)] \ddot{\theta} - M_1 L_p \ddot{\delta}_p$$

$$\begin{aligned} \bar{M} = & - [M_0 h_0 + M_1 (h_1 - L_p)] \ddot{x} - [M_0 h_0^2 + M_1 (h_1 - L_p)^2 + I_0] \ddot{\theta} \\ & - M_1 L_p (h_1 - L_p) \ddot{\delta}_p + [M_0 h_0 + M_1 (h_1 - L_p)] \theta + M_1 g L_p \delta_p \end{aligned}$$

$$\ddot{\delta}_p + \omega^2 \delta_p = -\frac{1}{L_p} [\ddot{x} + (h_1 - L_p) \ddot{\theta} - \alpha_T \theta]$$

where $\omega^2 = \alpha_T / L_p$
 $\Omega^2 = \alpha_T / (h_1 - L_p)$

Since this last equation of motion is not identical in form with equation (19), we make a change in variable. Let $\bar{\Gamma}_p = \delta_p - \theta$ making this substitution yields, in operational form,

$$(\mathcal{L}^2 + \omega^2) \bar{\Gamma}_p = -\frac{1}{L_p} [\mathcal{L}^2 \bar{x} + \mathcal{L}^2 h_1 \bar{\theta}] \quad (27)$$

Equation (27) is now identical in form with equation (19). If one next eliminates δ_p from the force and moment equations one obtains finally

$$\bar{F} = -\mathcal{L}^2 \bar{x} M_0 - \mathcal{L}^2 \bar{\theta} M_0 h_0 + M_1 \alpha_T \bar{\Gamma}_p \quad (28)$$

$$\bar{M} = -\mathcal{L}^2 \bar{x} M_0 h_0 - \mathcal{L}^2 \bar{\theta} (M_0 h_0^2 + I_0) + M_1 h_1 \alpha_T \bar{\Gamma}_p + (M_0 h_0 + M_1 h_1) \alpha_T \bar{\theta} \quad (29)$$

These equations are now identical in form with the hydrodynamic solution for the fixed field. Comparing term by term, the correspondences shown in Table 2 are found, thereby defining the desired mechanical analogy for the fixed acceleration field problem.

TABLE 2
ANALOGOUS MECHANICAL SYSTEM PARAMETERS
FIXED ACCELERATION FIELD

<u>MECHANICAL</u>	<u>HYDRODYNAMIC</u>
M_0	$M(1-A_1)$
h_0	$h\left(\frac{1}{2} + \frac{a^2}{4h^2} - B_2\right) / (1-A_1)$
M_1	MA_1
$M_0 h_0^2 + I_0$	$Mh^2\left(\frac{1}{3} + D_1 - B_2\right)$
h_1	$h B_2 / A_1$
L_p	α_T / ω^2
* h_1	$h(1 - \Omega^2 / \omega^2)$
* $M_0 h_0 + M_1 h_1$	$Mh\left(\frac{a^2}{4h^2} + \frac{1}{2}\right)$

*these relationships are already satisfied identically by the preceding equivalences.

It is interesting to note that the rigid portion of the mechanical analogies are identical in both Tables 1 and 2 and that the pendulums differ only in the height at which they are located. Because of the differences in their equations of motion however, the dynamic forces produced by these pendulums are identical in each case. It is only in the presence or absence of a static couple term that the results differ.

CONCLUSIONS

1. The forces and moments produced on a tank of fluid undergoing arbitrary small planar motions have been derived. (equations 19, 20, 21)
2. For the case of the tank moving in a longitudinal acceleration field carried with the tank, the forces and moments are duplicated exactly by a mechanical system (Fig. 2) whose parameters have been found (Table 1) and whose equations are given (equations 24, 25, 26).
3. For the case of the tank moving in a fixed acceleration field the forces and moments are duplicated exactly by a mechanical system (Fig. 2) whose parameters have been found (Table 2) and whose equations are given (27, 28, 29).

ANALYSIS
PREPARED BY
CHECKED BY
REVISED BY

C O N V A I R
A DIVISION OF GENERAL DYNAMICS CORPORATION
SAN DIEGO

PAGE 19
REPORT NO. ZU-7-069
MODEL 7
DATE 16 Oct. 1956

REFERENCES

1. Kachigan, K., "Forced Oscillations of a Fluid in a Cylindrical Tank"
Convair Report ZU-7-046, Oct. 4, 1955.

ANALYSIS
PREPARED BY
CHECKED BY
REVISED BY

C O N V A I R
A DIVISION OF GENERAL DYNAMICS CORPORATION
SAN DIEGO

PAGE 20
REPORT NO. ZU-7-069
MODEL 7
DATE 16 Oct. 1956

APPENDIX

APPLICATION TO MISSILE
EQUATIONS OF MOTION

SYMBOLS PECULIAR TO THIS SECTION

- y - transverse displacement of empty weight missile c.g.
- r - distance from empty weight missile c.g. to base of fluid tank, positive forward
- M_E - empty weight missile mass
- I_E - empty weight missile inertia about the empty weight c.g.
- T - rocket engine thrust
- $M_\alpha, M_\delta, F_\alpha, F_\delta$ - aerodynamic and rocket engine moment and force derivatives
- θ - missile attitude
- α - missile angle of attack
- δ - rocket engine deflection angle
- η - transverse displacement of effective missile c.g.

APPLICATION TO MISSILE EQUATIONS OF MOTION

Consider the missile of Fig. A-1. The equations of motion will be written for the empty weight missile center of gravity, treating the fluid sloshing forces as though they were external forces of known transfer function acting on the missile at the tank base station.

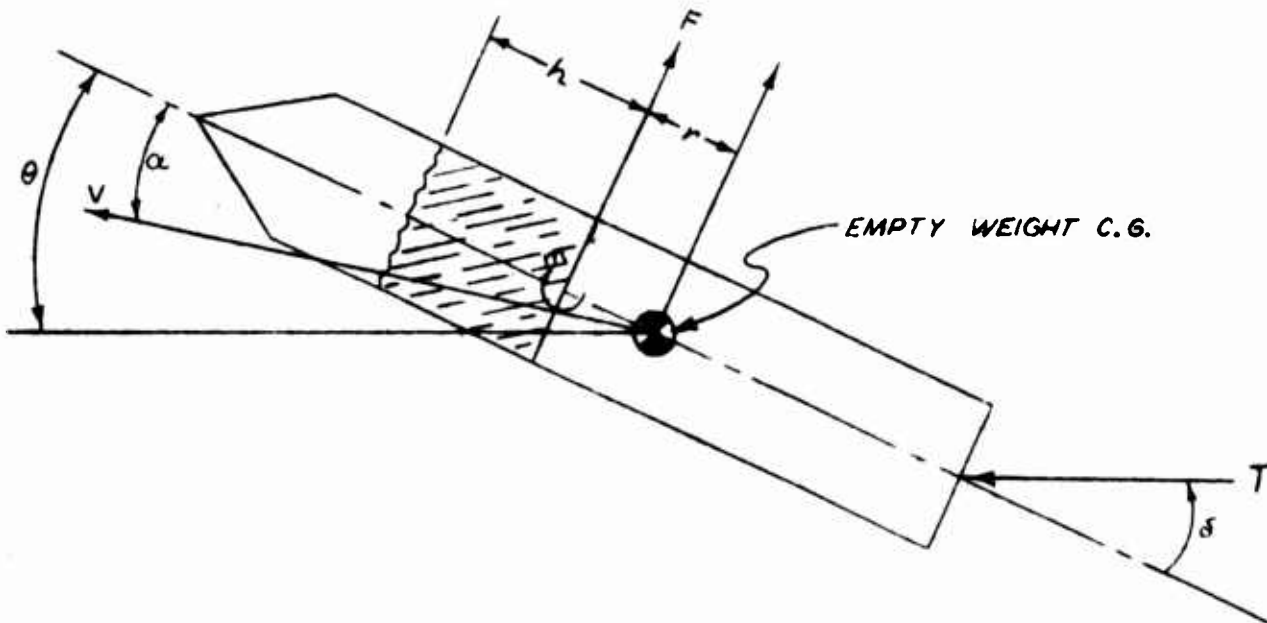

FIG. A-1

Summing forces and summing moments about the c.g. gives

$$\left. \begin{aligned} \Delta^2 I_E \bar{\theta} &= M_\alpha \alpha + M_\delta \delta + \bar{m} + \bar{F}r \\ \Delta^2 M_E \bar{y} &= F_\alpha \alpha + F_\delta \delta + \bar{F} \end{aligned} \right\} \quad (A-1)$$

where $M_\alpha, M_\delta, F_\alpha, F_\delta$ are aerodynamic and control moment and force derivatives.

Now from equations (19), (20) and (21) we may write the fluid forces as ("carried field")

$$\begin{aligned} \bar{F} = & -\Delta^2 (\bar{\psi} + r\bar{\theta}) M(1-A_1) - \Delta^2 \bar{\theta} Mh \left(\frac{1}{2} + \frac{a^2}{4h^2} - B_2 \right) \\ & + MA_1 \alpha_T \bar{\Gamma}_F \end{aligned} \quad (A-2)$$

$$\begin{aligned} \bar{m} = & -\Delta^2 (\bar{\psi} + r\bar{\theta}) Mh \left(\frac{1}{2} + \frac{a^2}{4h^2} - B_2 \right) - \Delta^2 \bar{\theta} Mh^2 \left(\frac{1}{3} + D_1 - B_2 \right) \\ & + Mh B_2 \alpha_T \bar{\Gamma}_F \end{aligned} \quad (A-3)$$

where $\bar{\Gamma}_F$ satisfies the equation

$$(\Delta^2 + \omega^2) \bar{\Gamma}_F = -\frac{1}{L_D} \left[\Delta^2 (\bar{\psi} + r\bar{\theta}) + \Delta^2 \bar{\theta} h \left(1 - \frac{\Omega^2}{\omega^2} \right) \right] \quad (A-4)$$

Substituting into equations (A-1) gives

$$\begin{aligned} & \left[I_E + Mr^2(1-A_1) + 2Mhr \left(\frac{1}{2} + \frac{a^2}{4h^2} - B_2 \right) + Mh^2 \left(\frac{1}{3} + D_1 - B_2 \right) \right] \Delta^2 \bar{\theta} \\ & + \left[Mr(1-A_1) + Mh \left(\frac{1}{2} + \frac{a^2}{4h^2} - B_2 \right) \right] \Delta^2 \bar{\psi} \\ & = [MhB_2 + MA_1 r] \alpha_T \bar{\Gamma}_F + M_a \alpha + M_s \delta \end{aligned} \quad (A-5)$$

$$\begin{aligned} & \left[Mr(1-A_1) + Mh \left(\frac{1}{2} + \frac{a^2}{4h^2} - B_2 \right) \right] \Delta^2 \bar{\theta} \\ & + \left[M_E + M(1-A_1) \right] \Delta^2 \bar{\psi} \\ & = MA_1 \alpha_T \bar{\Gamma}_F + F_a \alpha + F_s \delta \end{aligned} \quad (A-6)$$

Equations (A-5) and (A-6) may be recognized as the coupled equation of motion for a body referred to a point which is not the center of gravity. Such an identification is not readily apparent by means of substitutions of the symbols from the mechanical analogy of Table 1.

The result:

$$\begin{aligned} [I_E + M_0 (r+h_0)^2 + I_0] \ddot{\theta} + M_0 (r+h_0) \ddot{y} \\ = M_1 (h_1 - L_D + r) \alpha_T \bar{F}_R + M_2 \alpha + M_3 \delta \end{aligned} \quad (A-7)$$

$$\begin{aligned} M_0 (r+h_0) \ddot{\theta} + (M_E + M_0) \ddot{y} \\ = M_4 \alpha_T \bar{F}_E + F_2 \alpha + F_3 \delta \end{aligned} \quad (A-8)$$

The missile has a static unbalance of $M_0 (r+h_0)$ about the point to which the transverse displacements are referred. Hence, its effective c.g. is $M_0 (r+h_0) / (M_E + M_0)$ ahead of the empty weight c.g. This is the c.g. of the combined empty missile plus "rigid" fluid portion. The equations of motion may be uncoupled by referring the transverse displacements to the effective c.g. through the substitution

$$\bar{y} = \tilde{y} + \frac{M_0 (r+h_0)}{M_0 + M_E} \theta$$

From the foregoing it is seen that the concept of a "rigid" portion of the sloshing fluid, as developed in the pendulum analogy, is reaffirmed. The influence of the moving portion of the fluid, the magnitude and location of the pendulum force and the equation of motion of the pendulum, (reference equations (A-4) and (24)) are also reproduced in equations (A-7) and (A-8).

One further point to be noted is that in computing the fluid sloshing frequencies, the longitudinal missile acceleration, α_T , is computed as the quotient of net thrust and total mass ($M_E + M_0 - M_1$). The total fluid mass acts in this direction as is shown by equation (11) of the main text.