

AD 665295

NRL Memorandum Report 1851

**Fire Equipment Tests Aboard  
the CVA-62 Related  
to Improved Aircraft Carrier Safety**

H. B. PETERSON, R. L. TUVE, E. J. JABLONSKI  
R. R. NEILL, A. W. BERTSCHY, AND R. L. GIPE

*Combustion Suppression Research Center*

January 30, 1968

OR  
FEB 22 1968



Reproduced by the  
**CLEARINGHOUSE**  
for Federal Scientific & Technical  
Information Springfield Va 22151

**NAVAL RESEARCH LABORATORY**  
Washington, D.C.

This document has been approved for public release and sale; its distribution is unlimited.

**BEST**

**AVAILABLE**

**COPY**

## CONTENTS

Abstract	ii
Problem Status	iii
Authorization	iii
INTRODUCTION	1
EXPERIMENTAL TEST PLANS	3
TEST RESULTS	5
Wind Speed Measurements	5
NBC "Washdown" Flush-deck Nozzle Patterns	6
Deck-edge Positioned Nozzle Patterns	8
Sponge "Bomb" Model Water Pick-up	9
TBFFU Discharge Nozzle Performance	10
P-K-P Discharge	10
"Light Water" Application by Helicopter	10
High Expansion Foam Discharge	11
High Capacity Fog Foam System	11
DISCUSSION	
Wind Speed Measurements	12
NBC "Washdown" Flush-deck Nozzle Patterns	13
Deck-edge Positioned Nozzle Patterns	15
Sponge "Bomb" Model Water Pick-up	16
TBFFU Discharge Nozzle Performance	17
P-K-P Discharge	17
"Light Water" Application by Helicopter	18
High Expansion Foam Discharge	18
High Capacity Fog Foam System	18
CONCLUSIONS	20
RECOMMENDATIONS	22
ACKNOWLEDGEMENTS	22

## ABSTRACT

A series of tests were conducted at sea aboard the USS INDEPENDENCE (CVA-62) for the purpose of evaluating the application of the twinned agents, "Light Water" - Purple-K-Powder, from the Twin Ball Fire Fighting Unit, application of "Light Water" from a helicopter, and P-K-P from portable extinguishers. Also studied were the characteristics of the NBC "washdown" nozzles as possible basis for the introduction of a "Light Water" based installed fire protection system for the flight deck. Wind speeds and patterns were measured at various heights above the deck to establish their role in fire fighting operations. The major portion of the work was done under 30 knot winds characteristic of the wind speed during aircraft launch and recovery and representing the most severe conditions for extinguishing fires.

The air flow over the deck below the 6 ft level was found to be laminar in character with marked diminishment in speed at levels near the deck. Thus, the detrimental effects of wind on the discharge patterns of fire extinguishing agents was not serious in the down-wind direction but did severely limit the cross-wind agent reach.

The water distribution pattern from the "washdown" nozzles offers good potential as a base for a fire fighting system which with "Light Water" will offer both fire extinguishing and ordnance cooling capabilities. Average water application rate from this system is 0.03 gpm/ft<sup>2</sup> deck area, although the tests proved the wind-blown patterns were very uneven. Previous shore-based firetests have shown JP-5 fires can be readily extinguished at this application rate of "Light Water" spray. Simulated ordnance made of sponges demonstrated that water spray concentrations of 0.015 gpm were reaching each square foot of exposed munitions surface area. This is equivalent to absorbing about 150 BTU/min/ft<sup>2</sup>.

The discharge of water nozzles mounted along the edge of the flight deck and directed inboard was found to be highly deflected by the wind and will present a problem in properly designing a system for those carriers not already fitted with flush-deck nozzles. Additional testing on the pattern, flow, and angle of discharge will be required in order to obtain satisfactory results.

Extreme wind deflection of "Light Water" applied from the boom of the UH-2B helicopter dispersed the stream and made aiming to the site of the fire difficult. These and other helicopter operational problems lead to the recommendation that this method not be considered further for carriers.

Operation of two of the High Capacity Fog Foam System stations revealed problems in getting them into action within the desired time period of 30 sec. Their foam proportioning was found to be erratic but usually on the rich side. Foam concentrate replenishment rates were inadequate.

#### PROBLEM STATUS

This is an interim report. Work on the problem is continuing.

#### AUTHORIZATION

NFL Problem CO5-19

Bureau Nos. SF 015-07-02-3350,

Sub Project S 4624-006

**BLANK PAGE**

## INTRODUCTION

The study of fire protection systems for the distinct purpose of improving the operational safety of Naval aircraft carriers was a nearly completely neglected effort from the period 1949 to 1964. During this time significant advances in chemical and engineering research were made in applicable areas of methods and equipment for controlling and extinguishing fires. Unfortunately however, the pressure of attention to carrier safety problems did not rise to a point of action until the Navy had suffered two fire incidents of major proportions: The USS ORISKANY hangar deck pyrotechnic fire in October 1965, and the USS FORRESTAL flight deck fuel and ordnance fire in August 1967.

Because of the completely unexpected course of the fire on the flight deck of the FORRESTAL, a conflagration previously thought to be almost impossible, study groups and review panels were immediately formed to consider all factors involved in this fire, methods of preventing its recurrence, and the overall problem of fire safety aboard carriers.

The deliberations of these committees and of other authorities familiar with ship construction, carrier fire protection readiness, and existing equipment, reached consonance in the conclusion that some type of remotely controlled fire fighting and bomb-cooling system should be installed on the flight deck of aircraft carriers whereby fire extinguishment could proceed without exposure of personnel to the hazards of imminent explosion of munitions. The proposal was made that the existing system of exposed weather-deck continuous salt water washing by means of spaced water spray nozzles should be employed in some manner. This system was originally devised for nuclear, biological and chemical warfare "washdown" purposes.

Another conclusion was concerned with the need for emergency, quickly put into action, motorized, portable fire extinguishers of high efficiency, capable of controlling small initial fires before they grow into large conflagrations. This recommendation has been complied with by provisioning combat operations carriers with the NRL-developed shipboard Twin Ball Fire Fighting Unit, (see Fig. 1) the initial procurement for which was 21 units in October 1967. A second procurement of 120 units of this type of equipment is now being consummated for shipment to all aircraft carriers for flight and hangar deck use.

A third principal conclusion involved the need for a careful survey of the current operational characteristics of the 1948-designed High Capacity Fog Foam Systems with which all carriers are equipped.

The general survey of operational conditions existing aboard an aircraft carrier underway in the open sea with a 30 to 40 knot wind velocity along the long axis of the flight deck (aircraft launching and retrieval conditions), covered in this report, represent an entirely new assessment of the following hitherto unexplored factors directly bearing on the recommendations by the above-mentioned study groups for design and planning of new installations for efficient fire protection on the flight decks of ships:

1. Flight deck wind velocity profile patterns
2. Water distribution area - density patterns from the NBC "washdown" nozzle system on the flight deck
3. Water distribution patterns from deck-edge positioned nozzles
4. Dry chemical powder and "Light Water" extinguishing agent discharge pattern effectiveness when exposed to high wind velocities
5. Effective pattern of "Light Water" foam streams distributed by an overhead hovering helicopter
6. Water density rates of impingement on munitions suspended near the NBC "washdown" nozzle system
7. Operational efficiency of shipboard High Capacity Fog Foam systems.

The test results of the above factors were obtained during the period 29 November to 3 December 1967 aboard the CVA-62 USS INDEPENDENCE, in the open sea. Wind and weather conditions were not always optimum during the tests but significant data for planning purposes were obtained.

## EXPERIMENTAL TEST PLANS

In order to create a basic system of reference points for locating nozzles for each test and making measurements it was planned to lay out a series of accurately measured bench marks over the entire flight deck area of the aircraft carrier. Such a system would serve as a grid background for the cameras at elevated locations and subsequent distance measurements. It was planned to do the marking with strips of tape which could be easily stripped from the deck at the conclusion of the program.

Certain areas of the flight deck contain fixed equipment, such as catapults, subject to damage and corrosion by sea water and possibly the agents being used in the tests. For this reason it was the desire of the ships personnel to confine the test operations to the aft area of the flight deck insofar as possible. To receive assurance that the wind speeds and general wind flow conditions in the aft area were representative of other more forward areas, wind speed measurements were conducted over the entire flight deck area. These were made at varying heights above the deck to study the characteristics and existence of the boundary layer of flow. Two hand held, direct readout anemometers of the Navy type were used plus a Alnor heated wire type of velocity meter.

A series of water spray nozzles are mounted flush with the surface of the flight deck and discharge vertically upward. These nozzles were installed as part of the NBC "washdown" system which was designed to supply a flowing water coverage of all exterior areas of the ship while underway. The system is sectionalized by valves and the flight deck is divided into five sections which can be activated individually. Fig. 2 illustrates the individual nozzle locations and their sectional grouping. It was desired to determine the patterns of water impact on the deck and observe their suitability for use as the basis of an installed fire fighting system. Approximately 60 pans 1 ft x 1 ft x 2 in deep were brought on the ship with the aim of making different arrangements around the nozzle heads to measure actual water densities in gal per min per ft<sup>2</sup> reaching the deck around the nozzle. After timing the duration of discharge, the volume of contents of the pan was found either by dumping into a graduated cylinder or by reading the water depth.

The vertical aspects of the discharge were to be obtained by photographing the spray against a vertical grid or "witness panel." The panel was an 8 ft high and 12 ft long frame of 2 x 4's strung with line at 1 ft spacing in both directions. The open design minimized the wind resistance of the panel and made it manageable under high wind conditions.

Ships constructed prior to the CVA-62 (1959) do not have installed "washdown" systems and other means must be sought for providing an installed fire fighting system. Nozzles discharging from along the edge of the deck offer one possible approach to the problem. Several portable water nozzles of variable flow rates and discharge patterns were obtained to study the effective projection and deck pattern shooting athwartship across the wind flow.

The FORRESTAL incident vividly demonstrated the hazards of cook-off of ordnance suspended beneath aircraft wings when directly exposed to flame. It is essential to provide water promptly to such items to cool them and prevent temperature build-up. As a means of estimating the degree of cooling provided by the flush-deck nozzles, the overall shape of a Zuni rocket and of a 250-lb bomb was constructed out of sponges to be hung beneath the wing of an aircraft on the deck. The experimental concept involved here was the retention for later measurement of all water which impinged on a bomb so that a volume/area calculation could be made. These data when compared to heat input data from actual bomb exposure fire tests would establish the adequacy of the "washdown" system for ordnance cooling purposes.

The Twin Ball Fire Fighting Unit (TBFFU) as provided the carriers on Yankee Station in October 1967 and mentioned earlier in this report had never been tested on shipboard under the wind conditions normal to aircraft launch and recovery operations. This unit has a 4 lbs/sec Purple-K dry chemical discharge nozzle plus a 50 gpm "Light Water" discharge nozzle identical to the nozzles used on the Naval Air Station Twinned Agent Unit (TAU). These nozzles were to be discharged against the witness panel for observation of output stream characteristics.

The discharge patterns of the portable P-K-P dry chemical extinguishers recently furnished for flight deck usage had never been observed under 30 knot wind conditions. Their basic nozzle design is similar to that used on the TBFFU but the flow rate is only one half as much.

Two surveyed C-45 aircraft were put on board the carrier to serve as targets for the application of "Light Water" from the UH-2B helicopter. The UH-2B pilot was to maneuver over the aircraft and check his ability to accurately direct the foam discharge on the aircraft.

The high expansion foam nozzle was a portable 60 gpm device aerating the solution by air aspiration rather than by an externally powered blower as done with some generators. The foam may be characterized as a "low expansion high expansion" or very high expansion because its expansion is about 100 in contrast to a value of 500 to 1000 for ultra-high expansion foams and a value of 10 for other foam equipment normally found on the carriers. The plan was simply to discharge the foam out onto the flight deck and to observe the resultant flow patterns.

It was planned to check the operation of the High Capacity Foam Stations for response time, proportioning efficiency and nozzle pressure.

## TEST RESULTS

### Wind Speed Measurements

The original plan of laying out a series of accurately measured bench marks on the flight deck area using adhesive tape met with only partial success. The combination of a deck roughened with non-skid material and low air temperature would not allow any of the several types of tape available to exhibit any adhesion except for cloth-backed "Mystic" tape. The dark olive color of this material made it very difficult to see on the dark gray background of the non-skid material on the deck and it was necessary to put down yellow vinyl tape on top of the cloth tape.

After completion of the deck marking, two teams, each with an anemometer, took wind speed readings at 18 in, 24 in, 36 in, 48 in, 60 in, and 72 in above the deck. Other readings with the heated wire instrument were taken at limited points at levels down to 1 in and below. The small probe size of approximately 1/8 in diameter made this possible. Presentation of the data obtained is difficult to do adequately in a report of this type because of its three dimensional nature and necessitates a series of two dimensional plots.

Figs. 3, 4, 5, 6, and 7 are plots of the wind speed areas as found at the 18 in, 24 in, 36 in, 48 in, 60 in, and 72 in levels respectively. Fig. 8 is a profile of the wind speeds at the 72 in and 18 in levels down the centerline of the flight deck for its entire length. Fig. 9 is a profile of the variation in wind speed according to height above the deck and is based on average points along the full length of the deck.

#### NBC "Washdown" Flush-deck Nozzle Patterns

An outline plan of the CVA-62 flight deck indicating the location of the "washdown" flush-deck nozzles and the solid stream "cannon" nozzles mounted and discharging athwartship is shown in Fig. 2. The deck nozzles are designated "Type S" and are designed for welding into the deck. Construction of the nozzle is shown in Fig. 10. Its discharge rate at various pressure is shown in Fig. 11 and the discharge pattern at 30 psi under no-wind condition is shown in Fig. 12. At 30 psi the flow rate is 30 gpm and the area covered by the pattern is 1520 ft<sup>2</sup> (44 ft dia) which means the average calculated water application rate under still wind conditions within the spray pattern area is 0.02 gpm/ft<sup>2</sup>.

Fig. 13 illustrates a typical flush-deck nozzle installation surrounded by non-skid deck coating. Fig. 14 shows a portion of the placement of pans for collecting water from the nozzle pattern and their method of securing against the high ambient wind. The discharge pattern of a single nozzle is shown in Fig. 15 in front of the witness panel which is marked in 1 ft squares. The effect created by the approximate 30 knot wind is evident by severe sweepback in the "vertical" stream.

In Run 2 with the "washdown" systems only Section 6 was activated. The water collecting pans were secured to the deck around a single nozzle in the forward row of nozzles in this section so as not to be influenced from the discharge of other nozzles further forward. After observation of the deck pattern in Run 1, the pans were aligned for the most part directly downwind of the nozzle where the fallout was concentrated. The duration of the run was 9.75 min. At the conclusion of the discharge the contents of each pan was poured into a graduate for measurement and the water application rate calculated on a basis of gpm/ft<sup>2</sup>. In Fig. 16 the results of this test have been plotted in the manner of a contour map to describe the

pattern formed by the water falling on the deck. The highest concentration found was 0.045 gpm/ft<sup>2</sup>, which occurred 24 ft downwind of the nozzle.

In Run 3 Sections 4 and 5 of the "washdown" system were activated in addition to Section 6. The water collecting pans were arrayed around the same nozzle in the same way as Run 2, however, this time the pans also received water by wind driftage from nozzles in Section 5 located 40, 80, and 120 ft forward. After plotting the data in a contour manner as in Fig. 16, a different type of data presentation was prepared. In Fig. 17 the water application densities in gpm/ft<sup>2</sup> have been plotted as a function of the distance aft from the nozzle. For purposes of illustrating the amount of water carried back by the wind from Section 5 the comparable values from Run 2 have also been added to Fig. 17. Thus, the shaded area lying between the two curves represents the additional water superimposed on the discharge from the nozzle in Section 6. The actual increase in water application rate was from 50 to 300 percent, depending on the distance aft of the nozzle.

Fig. 18 is a view from a helicopter flying off the port side of the ship while Section 6 was being operated. Two nozzles in the forward row were plugged and one partially plugged and the outboard nozzle starboard in row 3 was also plugged. The resulting holidays on the deck are clearly visible. The water collecting pans can be seen lined out behind the second nozzle from the top of the picture in the forward row. The sponge "bombs" are suspended beneath the wings of the forward aircraft. Fig. 19 is a deck-level view of the same test operation. Full pressure at the nozzles was reached in 22 sec after the signal had been given to open the main valve.

Sections 4 and 5 of the "washdown" system were operated together with Section 6 in this test in order to gain a more comprehensive knowledge of the system and its patterns. The pan water collection values for this test were given in Fig. 17 above. Photographic views are shown in Figs. 20, 21, and 22. A considerable number of the nozzles appear to be only partially functioning. The effective range of the cross-deck directed water "cannons" is severely limited by the 30 knot wind and the highly elevated angle of nozzle aim. Time of response to full operation was 15 sec for Section 4, 20 sec for Section 6, and 40 sec for Section 5. Initial pump pressure was 140 psi.

Unfortunately, high winds and heavy rains occurring during the night before the tests of the "washdown" systems carried away all the tape grid markers. These would have been valuable aids in observing the effective range performance of the individual nozzles and defining the areas of inadequate water coverage. The masking of the catapults and other machinery on the flight deck with polyethylene sheet was only partially successful because of the poor holding power of the tape. The plastic was also weighted down with lengths of 2 1/2 in fire hose and wheel chocks. Final word as to the degree of intrusion and/or possible harmful effects by the salt water has not been received from the ship.

#### Deck-edge Positioned Nozzle Patterns

On the first day that the flight deck was available for wet testing a zero degree relative wind of 25 - 30 knots existed. Under these conditions two 1 1/2 in Select-o-flow nozzles were discharged toward each other from the deck level at the point where the narrow aft area of the flight deck begins (900 ft aft from the bow). These nozzles are of a type which discharge water at a constant flow rate regardless of the pattern setting between a straight stream and wide angle spray. In addition, the flow rate can also be varied between 60 and 120 gpm. It was found that with a 60 gpm flow the straight stream's maximum range was about 35 ft while at 120 gpm it was about 40 ft. At maximum width spray pattern setting the ranges were 6 and 10 ft, respectively. Pressure at the nozzle was 110 psi and each nozzle was inclined upward to approximately 30 degrees, the angle for greatest horizontal reach under no cross-wind conditions. Fig. 22 shows the straight stream appearance at the 120 gpm flow. Deck width at this point was 125 ft.

On the second day when deck-edge nozzles were run, the wind speeds down the deck were much lower, 5 - 10 knots, and thus the stream reach values are not comparable to the previous ones nor are they representative of those to be expected when the ship is launching or recovering aircraft. In this series the 1 1/2 in and 2 1/2 in Select-o-flow nozzles were tried plus a standard 2 1/2 in All-Purpose nozzle. The following results were obtained:

Nozzle and Setting	Flow Rate (gpm)	Max Reach (ft)
1 1/2 in Select-o str stream	60	50
full spray	60	6
str stream	120	60
full spray	120	10
2 1/2 in Select-o str stream	250	75
full spray	250	--
2 1/2 in APN str stream	130	100
full spray	130	15

During these runs the angle of the nozzle to the deck was varied and it was found that lower angles minimized the sweep-back of the stream by the wind and achieved a net increase in range.

#### Sponge "Bomb" Model Water Pick-up

Fig. 23 shows the sponge model of a Zuni rocket being rigged beneath the wing of the C-45 aircraft. The aircraft was spotted on the deck in the location indicated in Fig. 8. The sponge model, consisting of cellulose sponges cemented to a central wooden spine, was 5 in in dia and 101 in long. It was suspended 32 in above the deck as it would be normally found on an A4D aircraft and hung directly over one of the flush deck nozzles. This was an attempt to establish the maximum amount of impinging water that could be expected, however, during the run the constant buffeting by the wind caused the Zuni to swing in and out of direct impingement by the heavy vertical stream of the nozzle. The weights of water accumulated in each run were calculated back to a gpm/ft<sup>2</sup> of "bomb" surface area. The first and second runs were made with only Section 6 of the "washdown" system operating while in the third run Sections 4, 5, and 6 were operating simultaneously. The water impingement rates were found to be 0.012, 0.011, and 0.013 gpm/ft<sup>2</sup> for the three respective runs.

The sponge "bomb" constructed to simulate a 250-lb bomb was 8 in in dia and 43 in long including a semi-conical nose section. It was suspended beneath the opposite wing and about 25 ft from the nearest deck nozzle where the water density would be at about its minimum concentration. The water pick-ups with this device were 0.005, 0.015, and 0.017 gpm/ft<sup>2</sup> for the three runs as described above.

## TBFFU Discharge Nozzle Performance

The modification of the TAU "Light Water" - P-K-P equipment as used on shore air stations for shipboard application is shown in Fig. 1. Changes included removal of the Freon-12 system, storing the twin hose on a live reel, a side-by-side nozzle mounting, and placing the equipment on a smaller vehicle.

For purposes of these tests the agents were discharged by the ship's crew against one of the aircraft. It was found that good control of the agents could be achieved, provided the nozzleman was directly upwind of the target. The action of agents when directed at 90 degrees to the wind is illustrated in Fig. 25 where "Light Water" and Purple-K are being discharged straight upward into the wind stream. Discharge rates for this unit are about 4 lbs/sec for the P-K-P and 50 gpm for the "Light Water."

### P-K-P Discharge

A 30-lb capacity portable P-K-P extinguisher with a discharge rate of about 2 lbs/sec was discharged in a manner similar to that of the TBFFU dry chemical nozzle. A photograph of this operation is given in Fig. 26. It is to be noted that the air flow along the deck is fairly laminar in character and the chemical cloud has little tendency to billow upward. In fact the upper boundary of the powder cloud rose but slightly higher than the nozzle for the 18 ft of lateral movement visible in the photograph.

### "Light Water" Application by Helicopter

The UH-2B fire fighting equipment consisted of two 50 gal capacity "Light Water" solution tanks, a high-pressure gas source, and a nozzle mounted out on the end of the rescue boom. The nozzle is the same as the one on the "Light Water" tip on the TBFFU, discharging 50 gpm at 100 psi. Normally the pattern of foam travels straight downward from a height of 20 ft until it impacts the ground, however, in operation over the flight deck there is practically no straight downward portion, as may be seen in Fig. 27. The large degree of backward sweep required the pilot to allow a very long lead in order to hit a desired spot. The pattern and point of impact are clearly visible to the pilot and he may easily correct his position to achieve the desired result although some material wastage would be bound to occur. Considerable dispersion of the pattern indicated losses greater than those observed in land based applications of this system with low ground wind speeds.

### High Expansion Foam Discharge

At the time available of operating the generator the wind speed over the deck was in the 5 - 10 knot range and the results were not considered to be representative of the worst conditions to be encountered at the time of fire. Under the winds observed it was possible to lay down a blanket of high expansion (estimated to be 100) on the deck about 6 in deep with little loss by blow-off, however, within a minute the covering had almost completely disintegrated.

### High Capacity Fog Foam System

Two HC Fog Foam stations of the 17 on board were checked out for response, pressure, and proportioning under high and low flow rates. All lines were discharged over the side to avoid contact with the ship.

On Station 17 50 ft of hose were attached to the flight deck catwalk hydrant with a 2 1/2 in FFF nozzle and similarly a 2 1/2 in and a 3 1/2 in nozzle on the hangar deck level. It was found that after 15 sec from activating the push-button control at the flight deck hydrant water was being discharged and after 30 sec foam was being made. The following summarizes the other data:

Nozzle Arrangement	Nominal Flow (gpm)	Nozzle Pressure (psi)	Conc. (%)
one 2 1/2 in Flight Deck	250	65	7.3
one 2 1/2 in Hangar Deck	250	84	9.6
one 3 1/2 in Hangar Deck	500	--	1.8
All	1000	72 Hangar 52 Flight	3.1 Hgr. 7.4 Flt.

Station 10 was checked by connecting a 3 1/2 in line to the monitor and a 2 1/2 in line on the hydrant both on the hangar deck level and running them over the side at one of the port side refueling positions. The following data were obtained:

Nozzle Arrangement	Nominal Flow (gpm)	Nozzle Pressure (psi)	Conc. (%)
one 2 1/2 in FFF	250	108	4.8
one 3 1/2 in	500	--	6.3
one 2 1/2 in and one 3 1/2 in	750	88	7.6 (2 1/2) 6.2 (3 1/2)
one 2 1/2 in	250	95-108	3.8

At Station 10 an endurance run was made in order to determine the length of time one full tank (300 gal) of foam concentrate would last while supplying one 2 1/2 in nozzle without dumping additional 5 gal cans. It was found that an operating time of 18 min was possible.

Visual observation of the depth of color of the foam streams from both stations indicated wide variations in concentration even when operating at one fixed flow rate.

## DISCUSSION

### Wind Speed Measurements

The normal operation of a carrier during the launch and recovery of aircraft requires a course and speed which will create a zero degree bearing relative wind with a relative speed over the deck, forward to aft of 30 knots. This probably represents the most severe condition for fighting a fire on the flight deck not only because of wind effect on the agents but difficulties are created in personnel communications and footing on the open deck.

On the other hand this wind can be used to an advantage to direct the flames and heat overboard away from other aircraft. Maneuvering a ship of this size to bring about a favorable wind and direction will require a number of minutes so at least the first fire attack must be made under the initial prevailing wind condition.

Study of the wind speed plot for the level 6 ft above the deck shows that the speed was in the 21 - 26 knot range for the greater part of the deck area. There were small regions of lower speeds which usually occurred along the deck edges caused by localized structural features. These were probably accompanied by localized turbulence but no attempt was made to establish them accurately.

As would be expected from normal frictional considerations, the wind speeds decreased as the height of measurement approached the deck. At the 1.5 ft level, large areas were in the 15 knot and under range. The plot given in Fig. 6 illustrates this variation in a profile form down the full length of the center line of the flight deck. In general the trends in speed were in parallel agreement, gusts probably causing the deviations. In order to give a better picture of the variation of the wind speed due to friction effects of the deck, the speed readings down the centerline were averaged

for each height, as shown in Fig. 9. At the 1.5 ft level the speed was 70 percent that of the 6 ft level. Readings with the heated wire anemometer are not given for the levels below 18 in because of a discrepancy in calibration between this device and the rotating anemometer. The latter instrument was lost at the conclusion of the tests which precluded rechecking of the calibration.

It was concluded from the wind studies that no unusual conditions exist on the flight deck which would detrimentally affect fire fighting operations any more than the same wind on land. Maximum winds to be encountered are approximately 30 knots without significant turbulent regions. With aircraft spotted on the deck it is to be anticipated that the average wind speed below the 6 ft level will be well below 30 knots but accompanied by turbulence in the lee of the aircraft. The most critical area in a flammable liquid type fire is down on the deck itself and this is where the agent must be directed to accomplish its extinguishing action most efficiently. Here the wind speed is probably only about 50 percent of the maximum 30 knot speed found at the 6 ft and higher levels. It was further concluded that test work involving fire fighting agents and techniques could be conducted on the aft portions of the flight deck, behind the catapults and arresting wires, with the knowledge that the wind environment there was representative of all flight deck areas.

#### NBC "Washdown" Flush-deck Nozzle Patterns

The average water application density within the pattern area of the Type S flush deck nozzle (Fig. 12) calculates out to be 0.02 gpm/ft<sup>2</sup> under no wind conditions. This density value is based on a flow rate of 30 gpm per nozzle, which in turn is based on an assumed nozzle butt pressure of 30 psi. The actual operating pressure during these shipboard runs could not be determined because there was no location available for tapping in a gage. The wind effect on the discharge pattern may be seen by comparing the no-wind pattern of Fig. 12 with Figs. 15 and 16. In place of the 30 ft vertical plume, a 6 ft high, severely bent plume is found. In place of the 44 ft dia circular area an elliptical pattern is found with the nozzle located at one end of the long axis of the ellipse. The limited number of water "fallout" test pans did not permit the accurate determination of a full windblown nozzle pattern. The maximum density measured downwind on the centerline where the heaviest fallout occurred was 0.047 gpm/ft<sup>2</sup>. It was estimated that the short axis of the elliptical pattern did not exceed 10 ft.

Spacing of the flush-deck nozzles was highly variable over the deck area. The area between elevators 3 and 4 was heavily covered as was the bow area, Section 2. For no-wind conditions the average water application rate figures out to be 0.050 gpm/ft<sup>2</sup> for Section 2, 0.05 gpm/ft<sup>2</sup> for Section 3, 0.095 gpm/ft<sup>2</sup> for Section 5, and 0.023 gpm/ft<sup>2</sup> for Section 6. The overall rate for the entire flight deck is 0.03 gpm/ft<sup>2</sup>. The elongating effect of the wind on each pattern leaves relatively dry areas between the rows of nozzles when they are viewed as running in a fore and aft direction. Alternate rows of nozzles running athwartship are staggered in order to minimize this condition. Nozzles are concentrated in the forward portions of Sections 2 and 6, evidently with the idea of letting the wind carry the water aft to the more sparsely covered areas. This concept may be valid for washdown purposes but most of the spreading will occur on the deck itself and it cannot be considered effective for ordnance cooling. Also, in less than full wind conditions there will be many areas of low water concentration. This also means that "Light Water" applied from the flush-deck nozzles will be required to extinguish the fuel by a completely "horizontal" surface spreading action rather than the more normal method of spraying it directly on the surface.

Through the simultaneous activation of washdown Sections 4 and 5, some rough figures were obtained on the amount of "drifted" water or water contributed by nearby nozzles. The pans were placed behind the same nozzle as used in Fig. 15 but the three nozzles in front of it in Section 5 supplied an additional amount of water application. The added increments varied with the distance from the nozzles in the amount shown in Fig. 17. The maximum application rate found was 0.065 gpm/ft<sup>2</sup>.

The flush-deck nozzles are limited in Sections 1 and 4 to the area along the portside edge and reliance is placed on the flush deck "cannons" for coverage. From Figs. 20 and 21 it can be seen that their effectiveness is limited because of the wind "sweep" of the streams.

The activation of the shut-off valves controlling the various sections was accomplished manually upon intercom command from Primary Flight Control. The response time of approximately 20 sec was considered to be acceptable in the event the system was to be used as a fire fighting system. A wet type system would probably permit an even faster response time but the nozzle design and the nature of the fire fighting agents do not lend themselves to a wet system arrangement. In the conversion of the existing system to fire fighting the shut-off valves should be changed to quick-opening types remotely controllable from "Pri Fly."

It was noted that a considerable number of flush-deck nozzles were completely or partially blocked. This type of installation is highly susceptible to becoming fouled with dirt and debris over a period of time. When the deck is being coated with anti-skid material the nozzles are sometimes masked, never to be found again. A better means of opening the orifices is badly needed. Something like a battery powered electric drill with the proper diameter and length bit, together with a jig, would allow ships personnel to go along the rows periodically and clean them out. It would also help to have a nozzle layout to serve as a check-off list to insure that all nozzles are at least accounted for.

#### Deck-edge Positioned Nozzle Patterns

Using the deck-edge mounted 1 1/2 in nozzles at the two flow rates of 60 and 120 gpm produced only a 15 percent increase in range for the 100 percent increase in flow in the straight stream configuration. The pair of opposing nozzles operating at 110 psi nozzle butt pressure and 120 gpm would not come close to covering the width of the flight deck even at the narrow portions, (125 feet). (See Fig. 23.) (This observed increase in horizontal reach for a doubling of flow rate is in agreement with published fire hose stream tables.) Thus, it is felt that a problem will exist in obtaining proper water coverage of the complete flight deck from a system of deck-edge mounted nozzles for a 30 knot wind condition. Careful design consideration will be necessary as to nozzle pattern, angle of elevation, flow rate, operating pressure and nozzle location. In order to provide for water distribution in an approximately uniform pattern across the deck under varied wind speeds, a variation in nozzle patterns from wide spray to straight stream will be required. The angle of nozzle elevation for best horizontal reach under no wind conditions is 32 degrees, however, these tests with the 90 degree cross-wind indicated that a greater horizontal range is obtainable with a flatter angle. Unfortunately, testing time available did not permit the collection of quantitative data on this function. From a rationalizing viewpoint, the higher the angle the more water stream interference can be expected from aircraft wings parked along the deck edge and extending over the catwalk. A low nozzle stream angle would only have to contend with wheels and landing gear struts, which are much smaller profiles than wings. The individual nozzle flow rate and pressure will determine its range and water application rate. Reach of the stream will vary approximately as the square root of the nozzle pressure and by an even lesser factor for the flow rate. Nozzle locations and directions will determine their efficiency for covering the deck for fire extinguishing purposes as well as for

cooling ordnance items on the planes. Additionally, a minimum of damage from sea water to aircraft not directly involved in fire but within the section being discharged can partially be controlled by the design of the installation of nozzles.

#### Sponge "Bomb" Model Water Pick-up

The data from the ordnance sponge models suspended from the aircraft wings revealed that the rate of water impact on the ordnance skin would be approximately 0.014 gpm/ft<sup>2</sup>. Previous laboratory studies with sponges showed 10 to 20 percent of a directed water spray would be rejected from the surface and drip off. This variation was related to the velocity of the impacting spray; the higher the velocity the greater the rate of rejection. The laboratory studies also found the sponge bomb to be saturated with water and incapable of further adsorption when its weight had doubled. (On complete immersion these sponges will absorb 8 times their weight.) During the shipboard test runs, the weight pick-up totaled only about one-third of the initial weight so it is fairly certain they had not become saturated with water. If the shipboard data is corrected for the estimated amount of water which was rejected, the water application rate to the ordnance skin surface would be 0.015 to 0.019 gpm/ft<sup>2</sup>. This represents a heat removal capability of approximately 135 to 175 BTU/ft<sup>2</sup>.

It was unexpected that the 250-lb bomb model located 25 ft from the nearest flush-deck nozzle retrieved almost exactly the same amount of water as the Zuni rocket sponge mounted directly over one of the nozzles. The explanation for this appears to lie in the "reflective" characteristics of the sponge model which probably simulates that for the actual metal weapons. The bomb model was in a space which was characterized by rapidly drifting spray, which had to be of very small droplets to be blown as far as 20 ft or more downwind, whereas the Zuni model was contacted from below by a semi-solid jet which ricocheted outward on contacting a small area on the skin. As a result, the only effective cooling water the Zuni model absorbed was from drifting spray which amounted to no greater a rate than that on the 250-lb bomb. These tests would indicate the degree of cooling of ordnance will depend to a large extent on the orientation toward the wind and drifting spray with only the projected surface or silhouette normal to the wind intercepting appreciable amounts of water. In any event the cooling will probably be restricted to one side of the weapon. In the shipboard tests the sponge models were turned almost broadside to the wind direction.

With diminishing winds below the full 30 knots the water cooling pattern will become increasingly localized and varying from good at some points to non-existent at others.

#### TBFFU Nozzle Discharge Performance

As described earlier, there were no particular problems encountered with the operation of the TBFFU nozzles or equipment. The agent discharge from both nozzles is strongly influenced by cross winds and a 30 knot wind at 90 degrees to the output will reduce the effective range to 2 ft or perhaps even less. Therefore, it becomes almost imperative in winds of 20 - 30 knots that the fire fighter be almost directly upwind of the fire while applying his agents. Conceivably, a different nozzle design could improve the cross-wind range but this would require an undesired sacrifice in performance at lower wind speeds. Likewise, adjustable stream nozzles have not proven satisfactory because of the problem of misselection of the proper position.

The laminar air flow with little vertical movement means that the agent should not only be released directly upwind but also at the same level as the fire. Agent projection and range will be as limited upward and downward to the wind flow as it will be across it. For a fuel spill fire burning on the deck the nozzles should be held low, but for a fire situated in an aircraft the nozzles should be held at a corresponding level.

Although it was not a part of these tests, the subject of the vehicle for transporting the TBFFU had been discussed earlier with Air Department personnel from the INDEPENDENCE. These talks were the basis for the decision to mount the "second generation" design units on the rear platform of the MD-3 towing tractor. This vehicle is widely used on carriers and has a low 36 in overall height to permit movement among parked aircraft. The platform mounting will allow the tractor to perform its normal towing duties without any interference and the platform can be easily transferred to another tractor in the event of engine or chassis maintenance.

#### P-K-P Discharge

The same comments as made above for the twin agents, "Light Water" and P-K-P, also apply to the discharge of P-K-P from 50 lb P-K-P portable extinguishers, however, the wind effect on the effective fire fighting range of the powder will be even more pronounced because of the lower mass flow rate of discharge from these extinguishers.

## "Light Water" Application by Helicopter

Application of a fire fighting agent from a hovering helicopter would have a big advantage of providing ready access to fires anywhere on the flight deck without regard to parked aircraft. During all flight operations, a helicopter, called "the angel," is airborne and ready to effect rescue of personnel from downed planes and this craft would provide an ideal platform for bringing "Light Water" to a fire situation within the deck-spotted aircraft "pack." The shipboard tests indicated that delivery and application of "Light Water" by helicopter was possible and probably could accomplish some fire extinguishment action even though the 30 knot wind condition would make it less efficient than the comparable land-based technique.

Strong objections to this procedure have been raised by the ships' operations officers. One objection is that the latest flight pattern for the "angel" calls for it to orbit the carrier at a distance instead of hovering off the island and this would incur a long delay in response. The biggest objection lies in the amount of fuel which would have to be traded off to permit carrying the "Light Water" unit. This would require more frequent return of the helicopter to the deck for refueling, which in turn interferes with other flight operations on the carrier.

## High Expansion Foam Discharge

The operation of the high expansion foam generator under 5 to 10 knot winds was not considered an adequate test of the characteristics of this agent for flight deck application. Adoption of this material cannot be viewed optimistically because of the cumbersome equipment required. Presently available high expansion foam generating apparatus cannot be readily adapted to the flush-deck nozzles nor to any system of deck-edge nozzles as a part of a fixed system and portable units would be slow to mobilize and almost impossible to handle in a 30 knot wind.

## High Capacity Fog Foam System

The basic form of the Fog Foam System was first introduced to carriers in 1945 after a series of preliminary tests conducted by NRL. Except for modifications made to convert it to a remotely controlled, dry type system with better proportioning at a flow rate of 250 gpm, it has remained essentially unchanged over the 20 year interim period. The system suffers from complexity of arrangements in the proportioning section, maintenance problems, and lack of usage, as do most fire protection systems.

Despite the above cited shortcomings, the two stations checked out on the INDEPENDENCE were found to function fairly satisfactorily. On Station 17 there were some problems in finding and properly setting the valves at the proportioner, but after these delays, the flight deck push-button control was finally closed, and water was received in 15 sec and foam in 30 sec. In the first acceptance tests (1946) of this type of system, foam was obtained in 17 sec. Response time to the flight deck within 30 sec is essential for prompt fire attack. The variation in depth of color of the solution flowing from the nozzle indicated fluctuations in foam concentration, however, only one sample taken at Station 17 was below the desired 6.0 percent value. There appeared to be no logical explanation of why the proportioning should vary while the water flow rate remained constant. Concentrations above 6 percent are beneficial in regard to fire fighting so the only concern here is premature depletion of the foam supply. Observed nozzle pressures were somewhat below the desired 100 psi level.

The endurance run made at Station 10 resulted in a duration of 18 min which is very close to the theoretical time of 20 min for emptying the 300 gal supply tank with one 2 1/2 in nozzle operating. This would indicate the average concentration was slightly over 6 percent.

It was observed during the runs that the foam concentrate stored in 5-gal cans near the proportioning station could not be dumped at a rate to keep pace with even the low flow rates. With the maximum flow of 1000 gpm the 300-gal tank will be exhausted in 5 min which is a relatively short time in a major fire. The standby supply of 300 gals at each station would not appear to be available rapidly enough at the time of a fire, especially if it had to be carried to another station. Consideration should be given to putting all the concentrate into a tank or tanks where it would be available for immediate and continuous use.

Examination of foam cans in the storage racks showed some of them to be 10 years old and new cans were stored alongside the oldest cans. It is advisable that protein foam concentrate should not be older than 3 years. A fixed policy of replacing any stored material older than 3 years should be established on all ships.

Although they were not a part of the fog foam system, very old x foam proportioners for portable use were noted in various locations throughout the ship. These outmoded and inefficient foam concentrate proportioners should have been replaced many years ago.

## CONCLUSIONS

It is patently superfluous to conclude at this point that the operation of a correctly installed aircraft carrier flight deck NBC "washdown" system (similar to the one tested aboard the CVA-62 (INDEPENDENCE)) would diminish the detrimental effects of fire and heat if a repetition of the FORRESTAL incident should occur. Heavy rainstorms have been known to accomplish the same ends.

From a quantitative viewpoint, it is impossible to forecast the exact degree of control of fire and heat attainable by operation of the system on the basis of the information obtained in these tests. However, certain data have now been gathered concerning the water pattern characteristics of a typical system during normal ships operating procedures. Certain other information has been developed by laboratory tests which relates closely to the shipboard results and confers considerable optimism to the efficacy of the "washdown" system for fire protection.

In a series of quantitative, field fire tests on a steel plate 19 ft in dia using JP-5 fuel, hand-held sprays of 6 percent "Light Water" extinguished and secured the fire in 7 sec at an application rate of 0.057 gpm/ft<sup>2</sup>; which is an application density of 0.007 gal/ft<sup>2</sup>. (Protein foam solution applied at 0.214 gpm/ft<sup>2</sup> required a density of 0.150 gal/ft<sup>2</sup>, 20 times that for "Light Water"; plain water at this rate could not extinguish the fire.) The calculated water rates for the flight deck varies between sections but averages to 0.03 gpm/ft<sup>2</sup>. Extrapolation of the extinguishing time based on the above rates would indicate extinguishment by the flush-deck "washdown" system should be accomplished within 13 sec using "Light Water" solution in it.

Testing is now underway (January 1968) at this Laboratory using a mocked-up 50 x 50 ft section of a steel deck in which carrier flush-deck washdown nozzles have been installed. Full scale fire tests at identical deck spray rates to those on board ship will be conducted.

The data obtained concerning area/water rate impingement on mock-up sponge "ordnance" indicated that a considerable cooling effect from upward projected and drifted water spray can take place by operation of the "washdown" system. Of course, the extent of this water impingement will be a function of the position of the

ordnance relative to the pattern of the water spray. Additionally, the heating characteristics of ordnance of differing configurations under flame and spray exposure will have a bearing on the "cook-off" prevention capabilities of the "washdown" system operation. It is worth noting in this connection that time lag between the start of heat input and initiation of cooling may generate a "point-of-no-return" concerning the internal penetration of the heat front. This also must be determined for each configuration before definite conclusions can be made.

It is evident even from the tests that were performed, that spray coverage of the flight deck will be very discontinuous using deck-edge positioned nozzles. Such an installation will require a careful series of tests under 30 knot wind conditions in order to establish optimum elevation and stream pattern characteristics of candidate nozzles, in terms of deck areas requiring protection. The interference of parked aircraft with deck-edge nozzle streams will continue to be an insoluble problem, it is believed.

The effective reach of extinguishing agents from dry chemical portable extinguishers and from the "Light Water" and "Purple-K-Powder" twin nozzle of the TBFFU was severely limited by high cross-wind velocities. Since these devices are easily portable and hand-directable, the fire fighter can usually point the nozzle in an easily seen, exactly downwind direction at the lowest position to the deck where wind velocity and turbulence do not adversely affect the discharge pattern.

It was disappointing to note the extreme deflection by wind velocity of the downward projecting stream of "Light Water" foam from the overhead hovering helicopter. It must be concluded that a fire extinguishing agent discharge which cannot be accurately aimed will be of minimal utility in an actual fire emergency.

The High Capacity Fog Foam System stations that were checked on the CVA-62 operated satisfactorily after a number of difficulties had been surmounted. These consisted of improperly designated control valves, problems of communications, difficulties of rapid handling of 5-gal foam concentrate recharging cans, poor disposal of empty cans, and inability of operation of sections of the system without manual control of automatic electrical relays. There is no question that the system needs engineering design attention immediately.

## RECOMMENDATIONS

Based on the findings of these shipboard tests it is recommended that engineering design studies of aircraft carriers be initiated leading toward the provision of flight deck water spray systems, preferably of the flush-deck mounted type, yielding uniform spray "fallout" on the deck of at least 0.02 to 0.03 gpm per sq ft under operating conditions. These systems should be designed for sectionalized, remotely-operated control and provided with automatic proportioning stations for admixture of 6 percent by volume "Light Water" Concentrate in the salt water mains supplying the sections.

It is also recommended that a complete review be made of existing High Capacity Fog Foam Systems including hangar deck sprinkler systems with the objective of increasing their effectiveness by utilizing "Light Water" in their operation and simplifying them.

## ACKNOWLEDGEMENTS

The tests described in this report would never have been accomplished without the initiative, encouragement and extraordinary degree of cooperation demonstrated by the Staff of the USS INDEPENDENCE at every occasion of contact with the NRL team. Dating from early in October 1967, CDR L. Kriser, Head of the Air Department and LCDR P. C. Alexih, Flight Deck Officer, CVA-62, visited NRL several times to plan the program and advise us concerning shipboard facilities. During the December tests, Captain C. A. Hill, Jr., the Commanding Officer of the INDEPENDENCE, ordered course and speed of his ship so that our test conditions would be optimum, even in the face of adverse weather. The authors wish to thank these officers and all other members of the ship's company who contributed their wholehearted efforts to complete the test requirements.

Appreciation is also due to Captain J. S. Endacott, CNO OP-506, who coordinated the arrangements for the ship's facilities; Messrs. G. DeLauder, Perry Green and William Connick, of the Graphic Arts Department, NRL, for their excellent motion picture and still photographic coverage; and to Mr. Charles S. Butler, a member of the staff of the Center, who discharged his duties on the flight deck when others had sought cover from the severe weather.

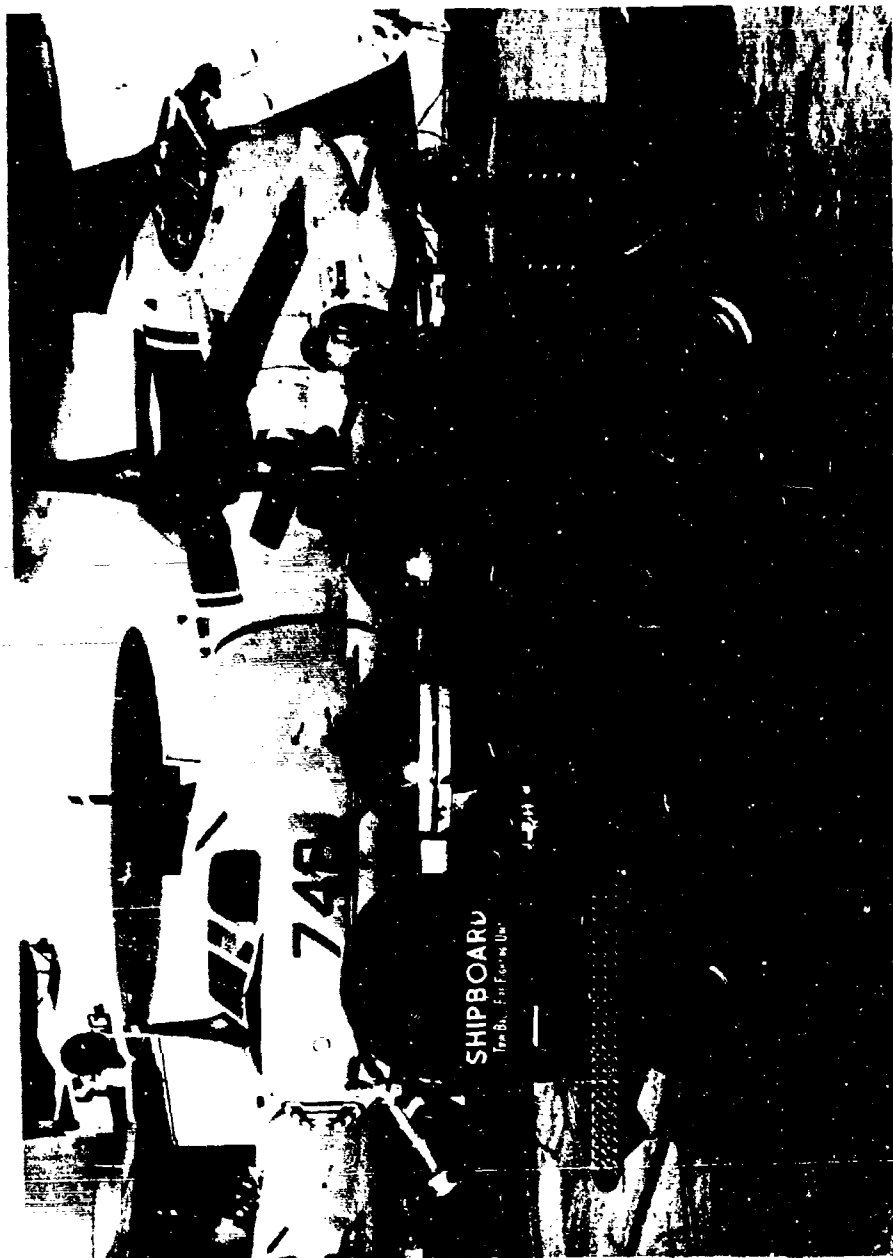

Fig. 1 - The Shipboard Twin Ball Fire Fighting Unit (TBFFU) mounted on the 4.0 airfield utility vehicle aboard the USS INDEPENDENCE. Similar units and vehicles were furnished carriers on Yankee Station in September 1967.

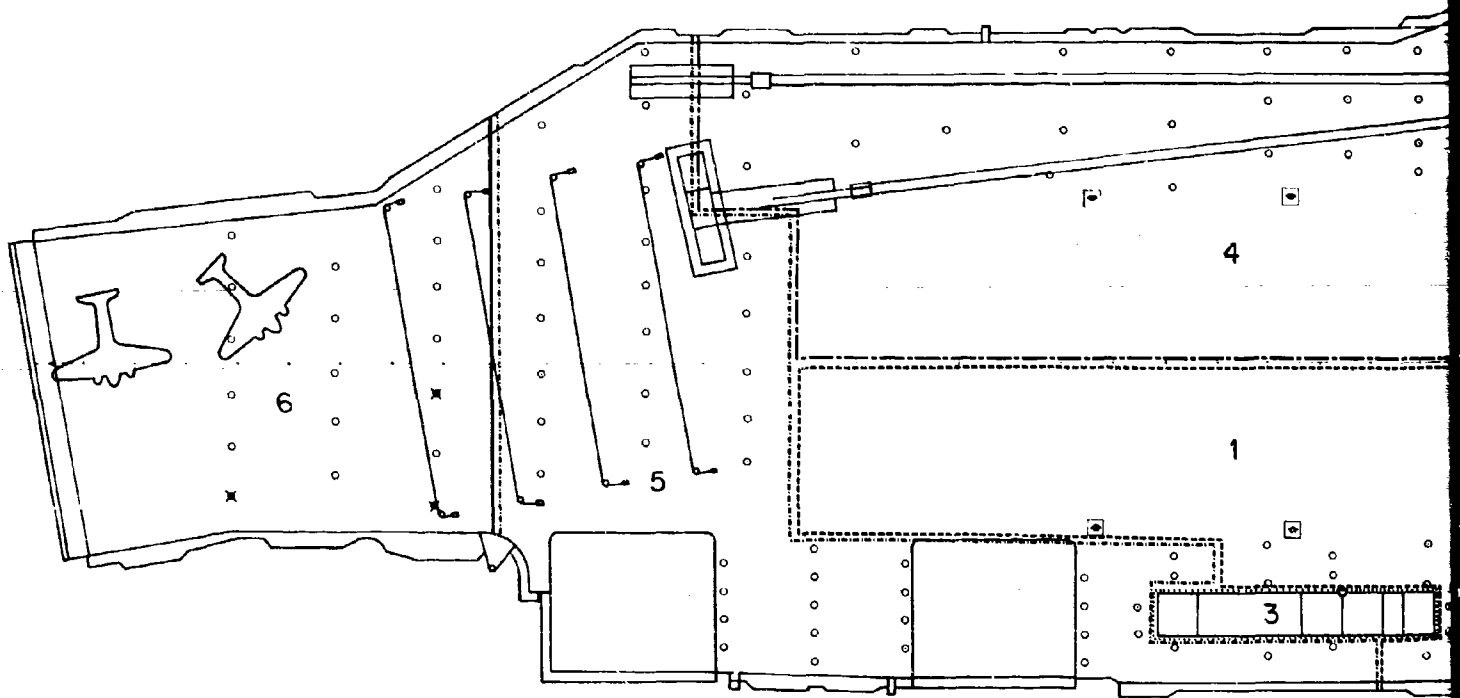
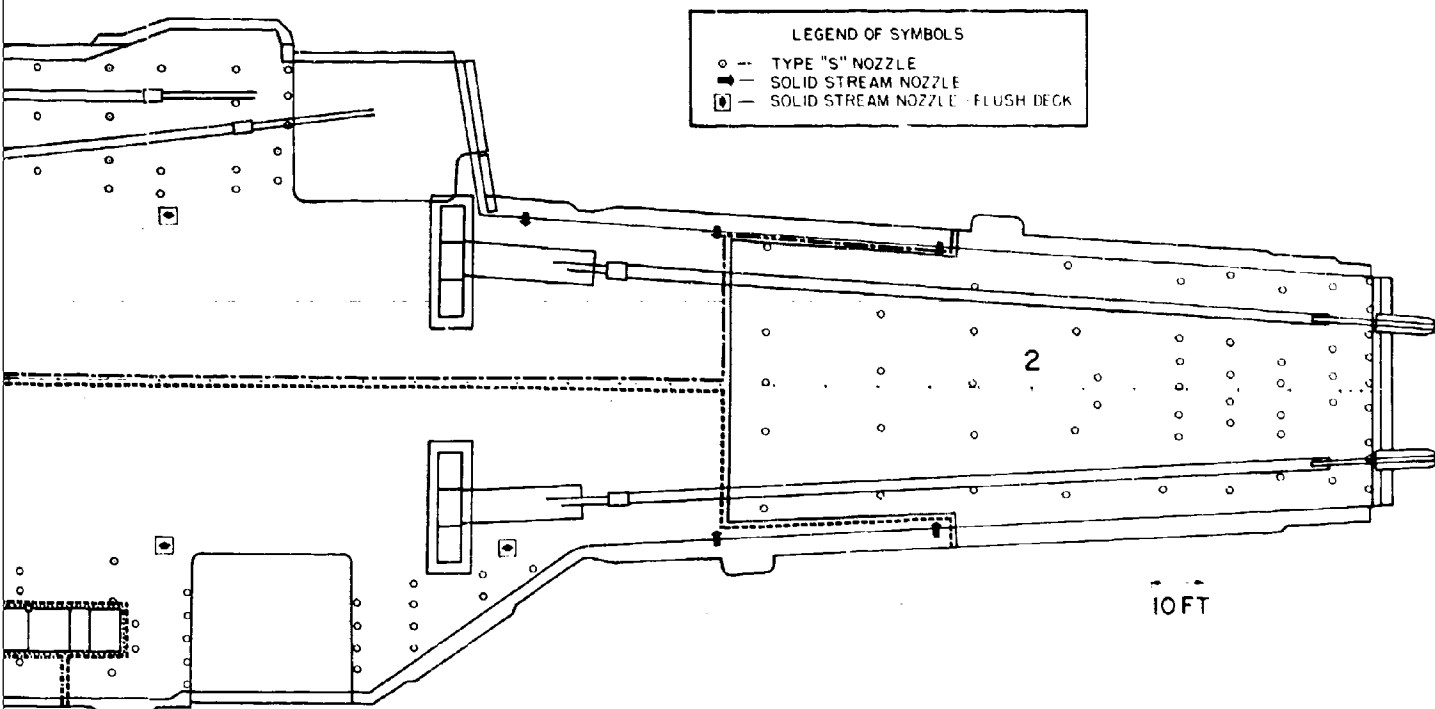

Fig. 2 - Outline plan of the flight deck (6 locations of the elevators, island and catalytic nozzles comprising the NBC "washdown" and their sectionalized grouping. The "X"

A



flight deck (04 level) of the CVA-62 showing the washdown and catapults. Also located are the individual "washdown" system for the flight deck area. The "X"'s denote nozzles found plugged.

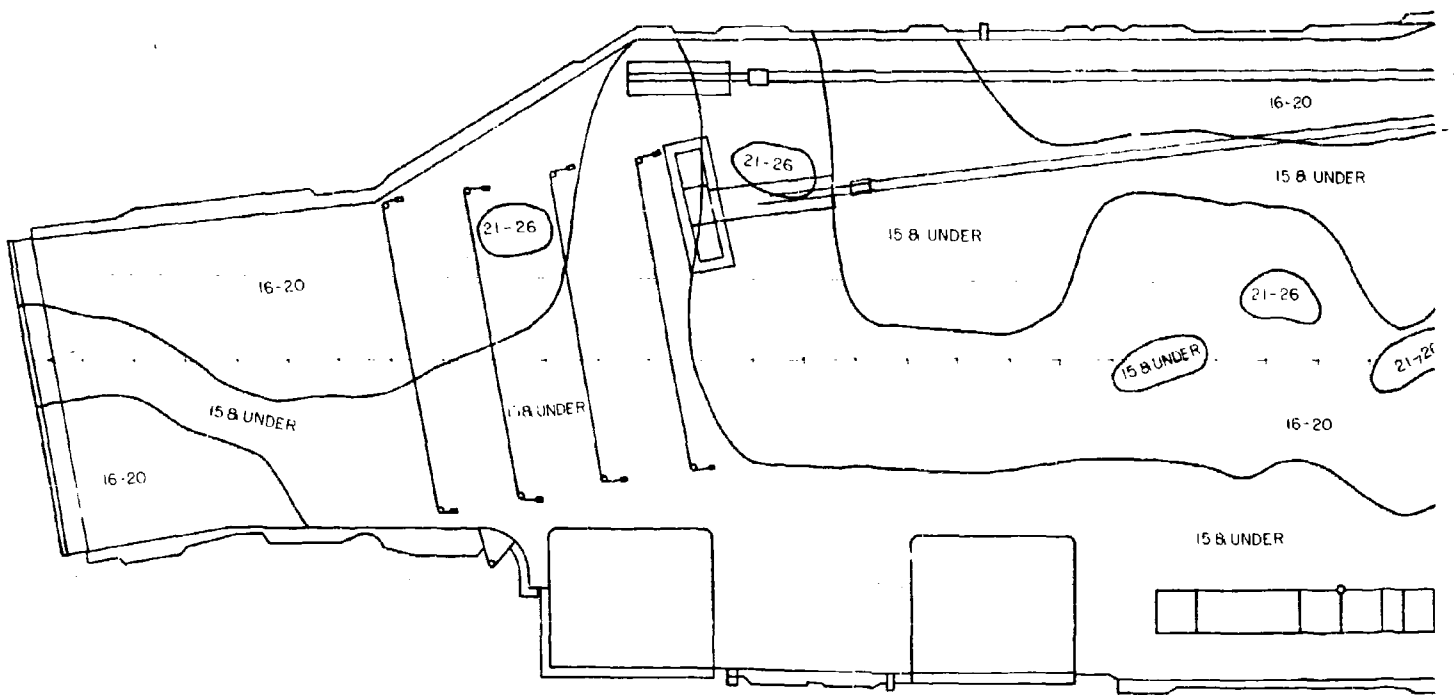
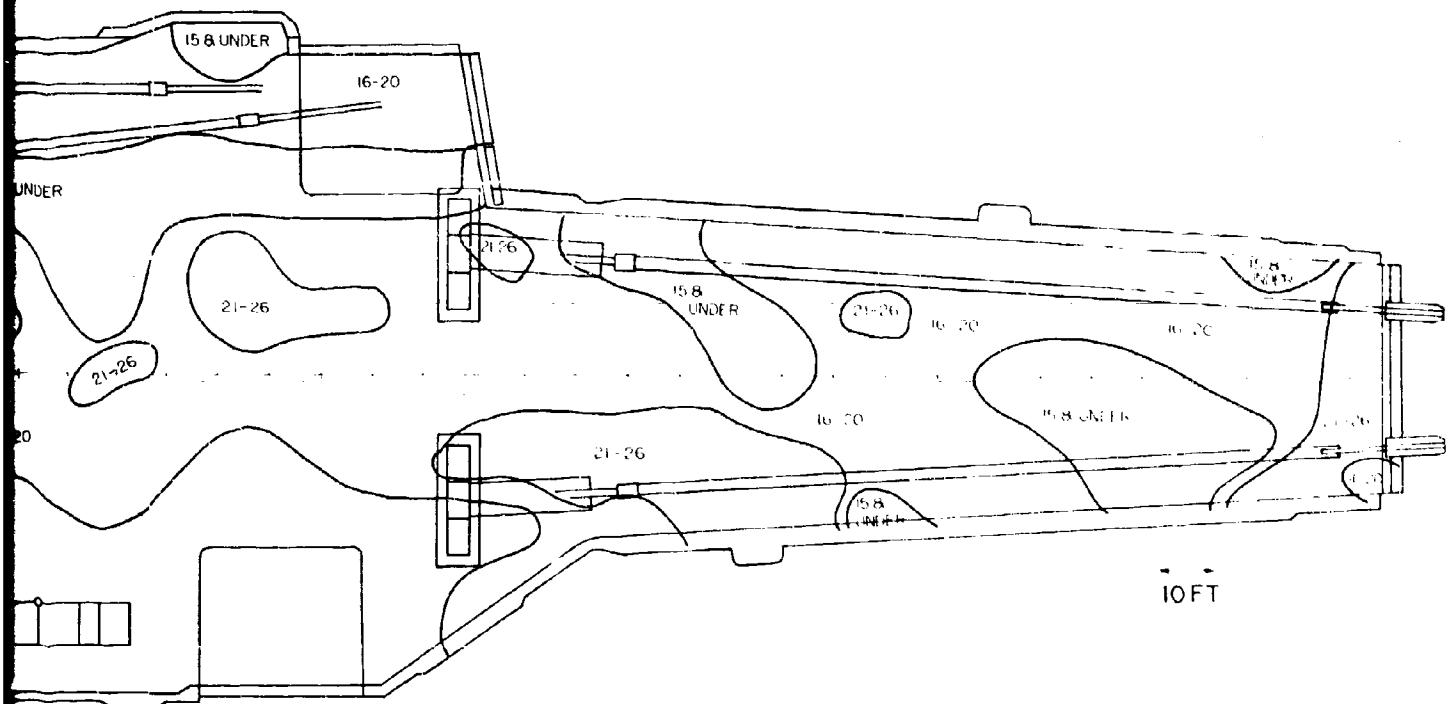

Fig. 3 - Wind speeds over the flight deck a



ht deck at the level of 18 in. above deck

B

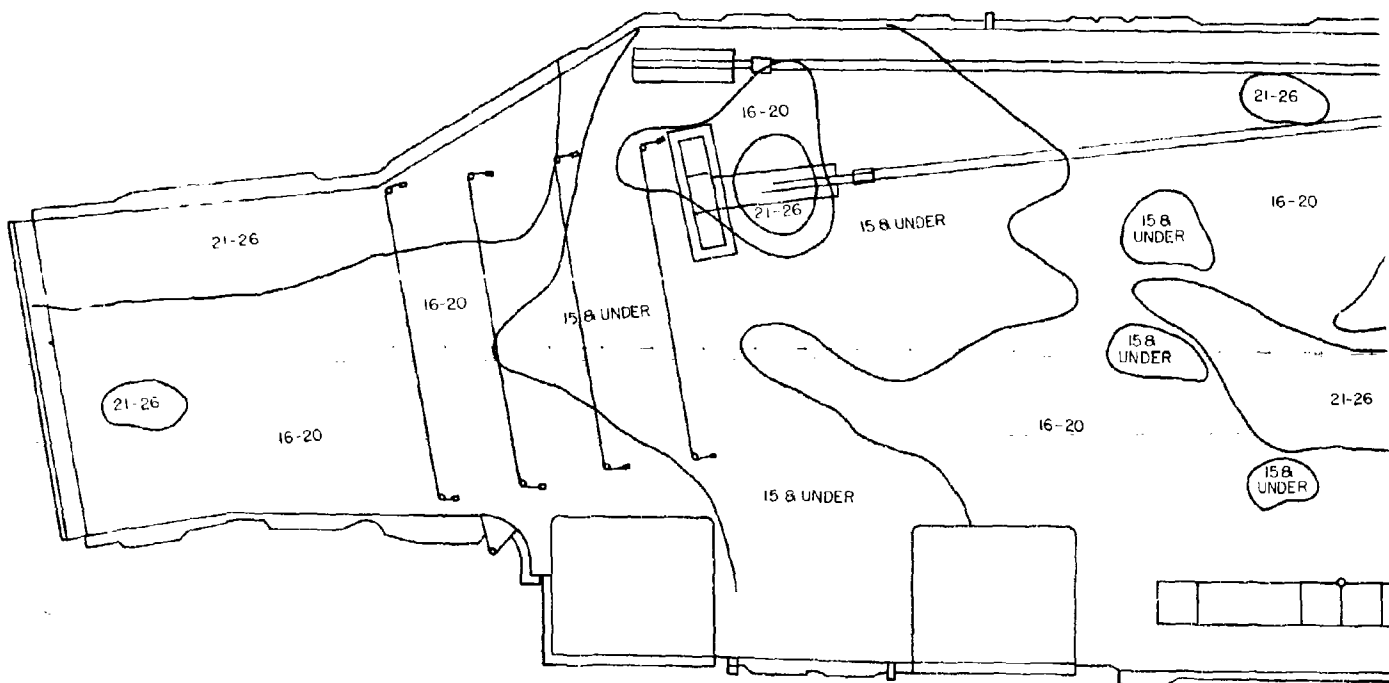
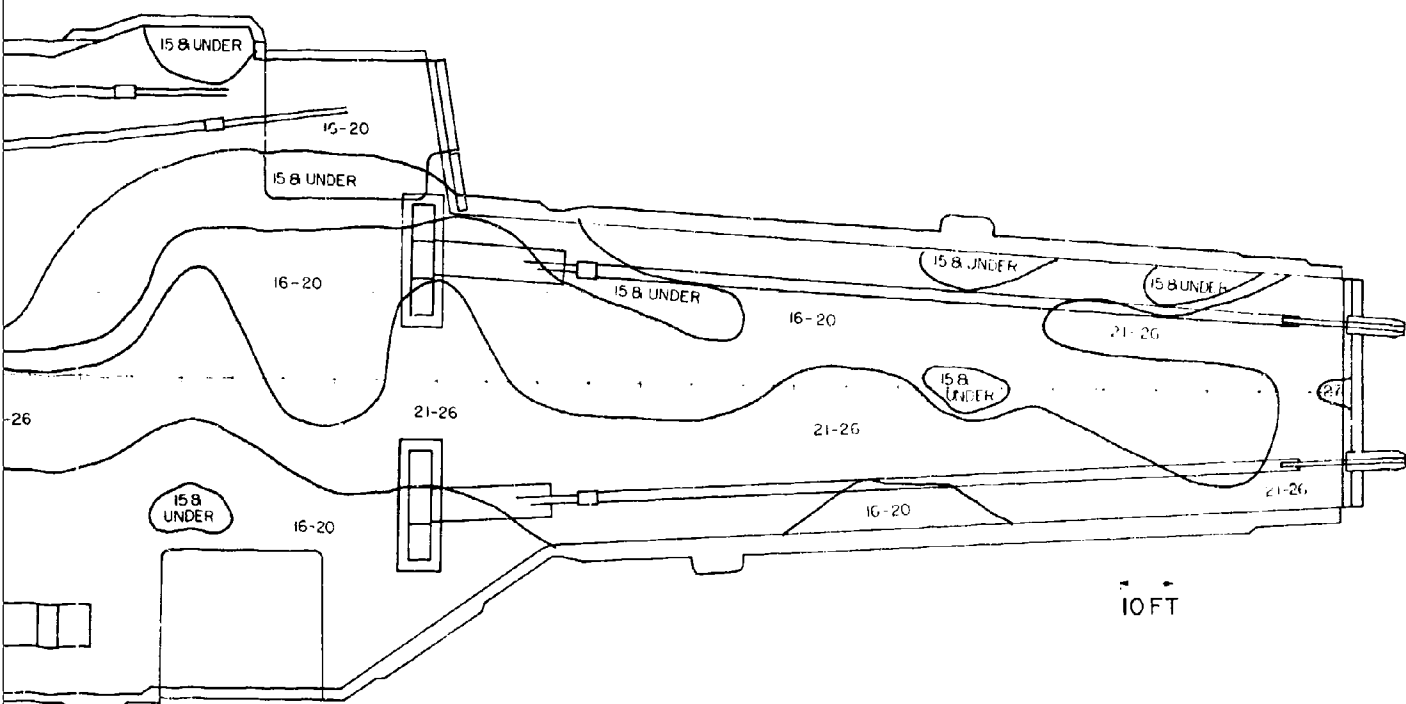

Fig. 4 - Wind speeds over the flight deck at

A



k at the level of 36 in. above the deck

B

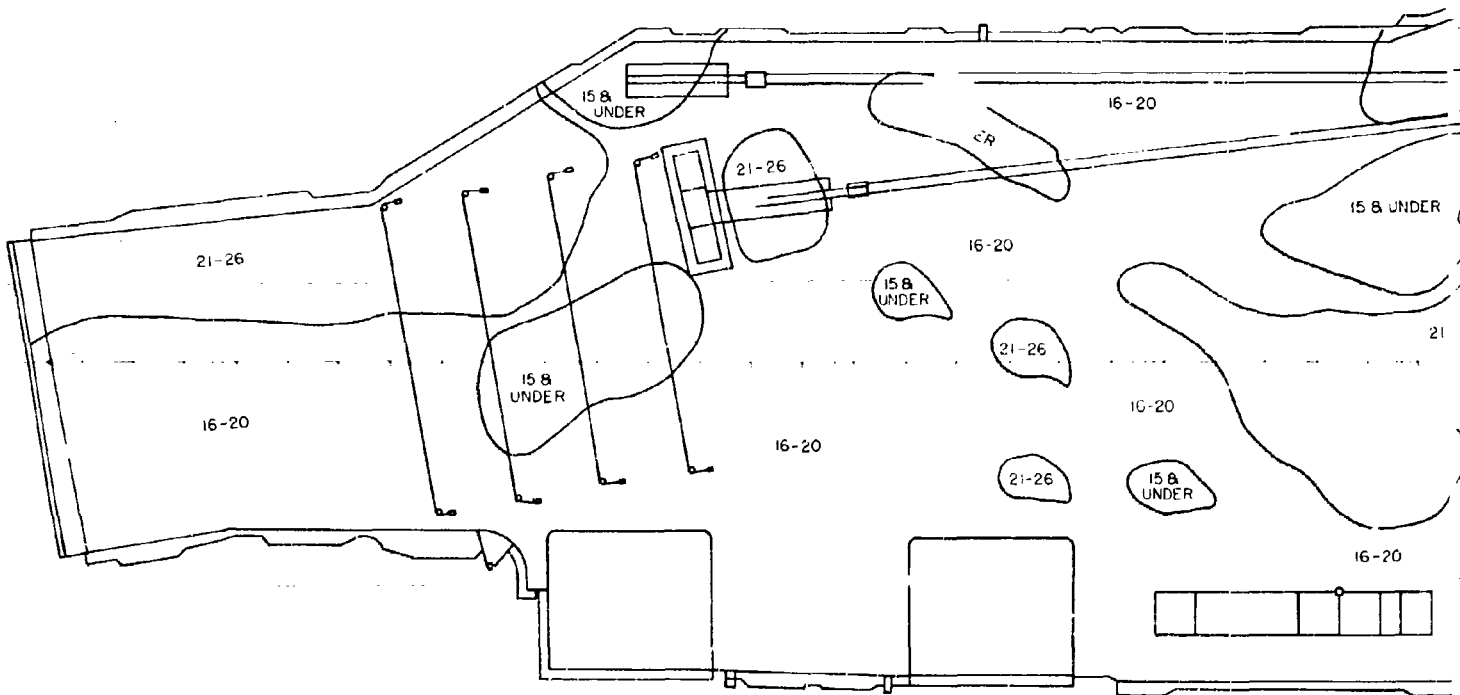
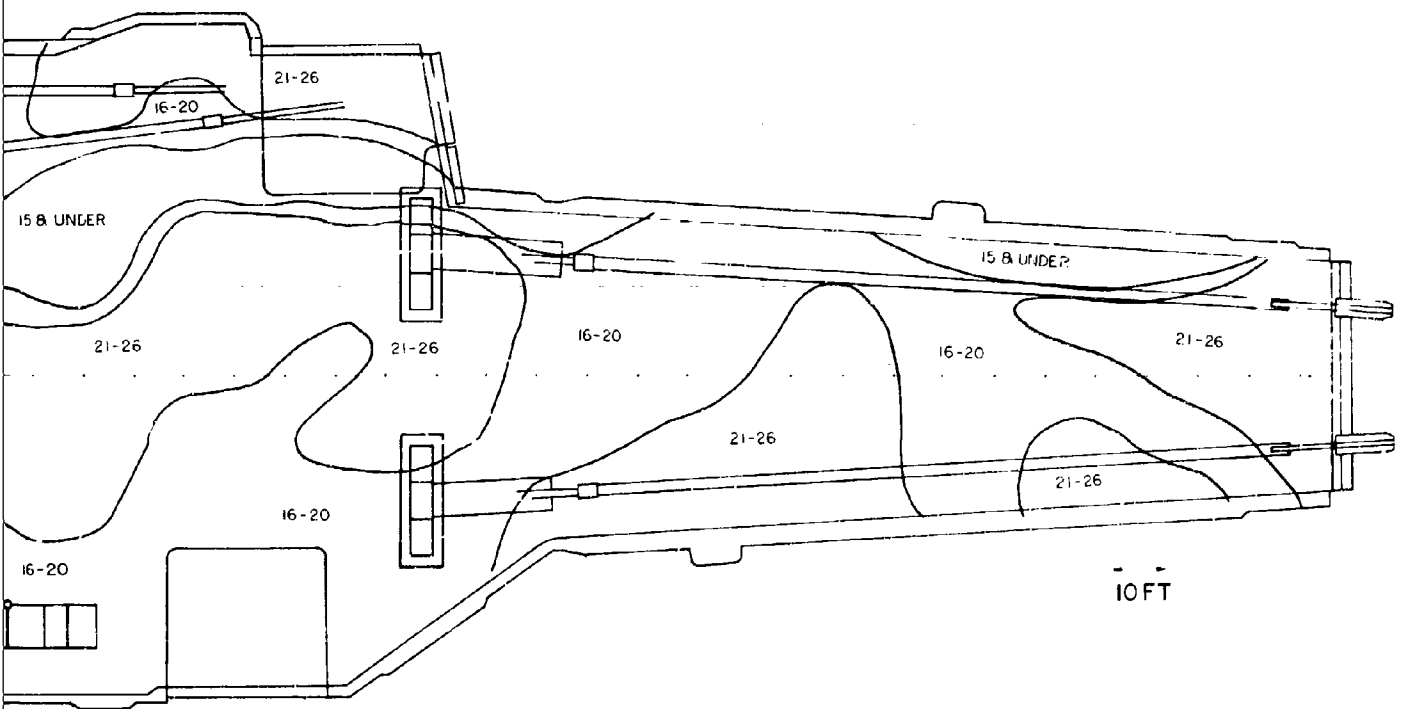

Fig. 5 - Wind speeds over the flight deck at t'



deck at the level of 48 in. above the deck

8

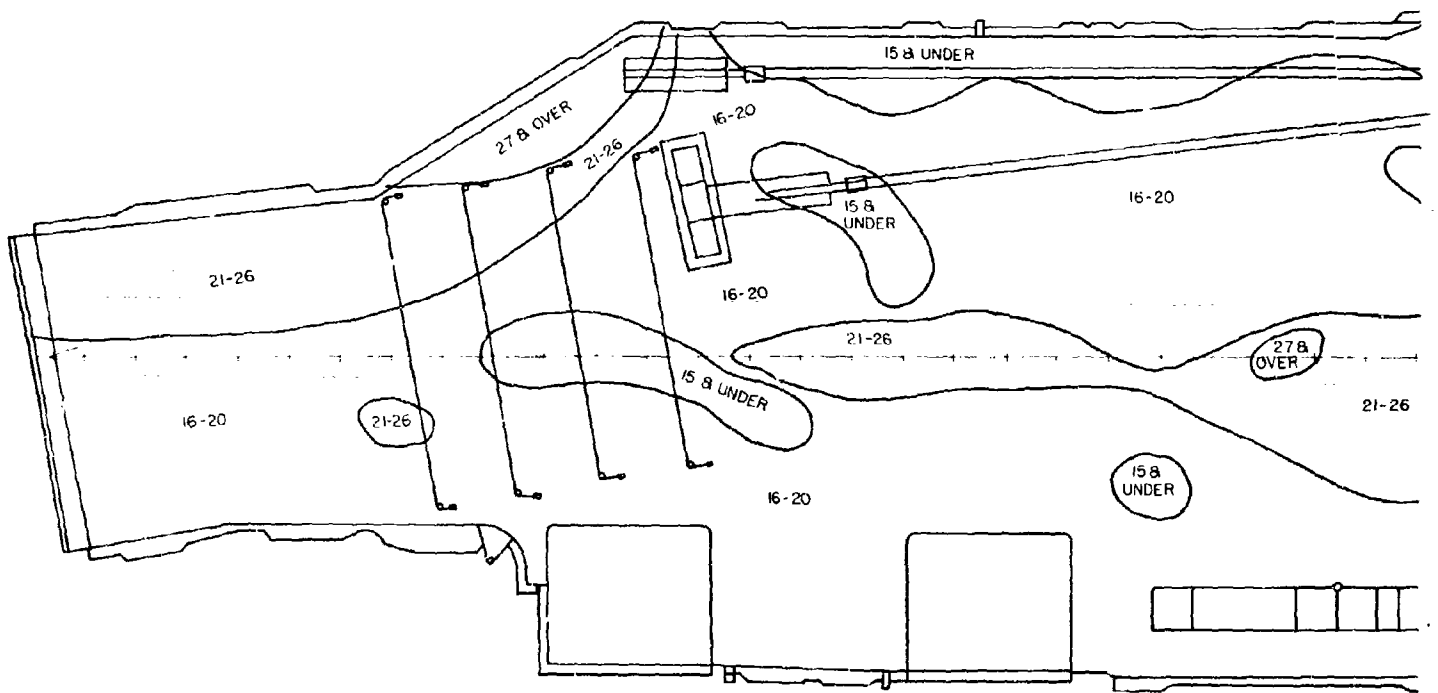

Fig. 6 - Wind speeds over the flight deck :

A



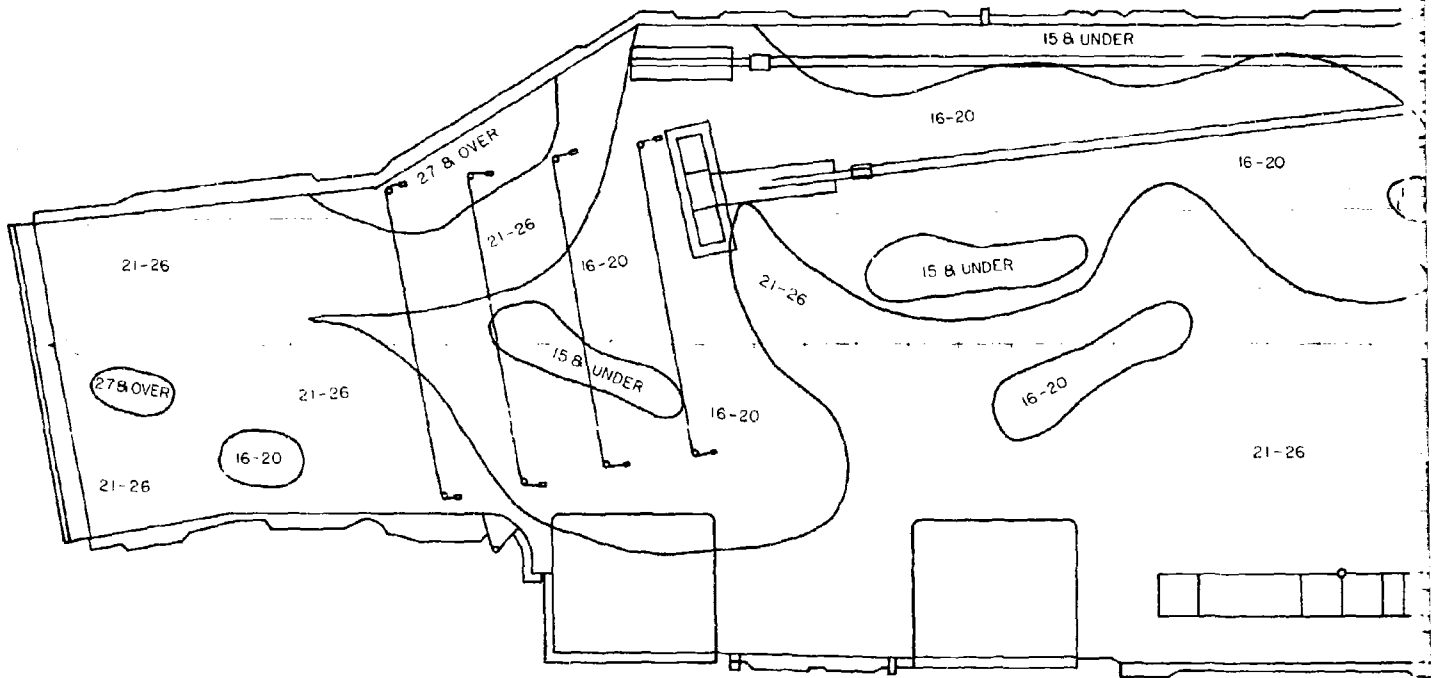

Fig. 7 - Wind speeds over the flight deck a

A



**BLANK PAGE**

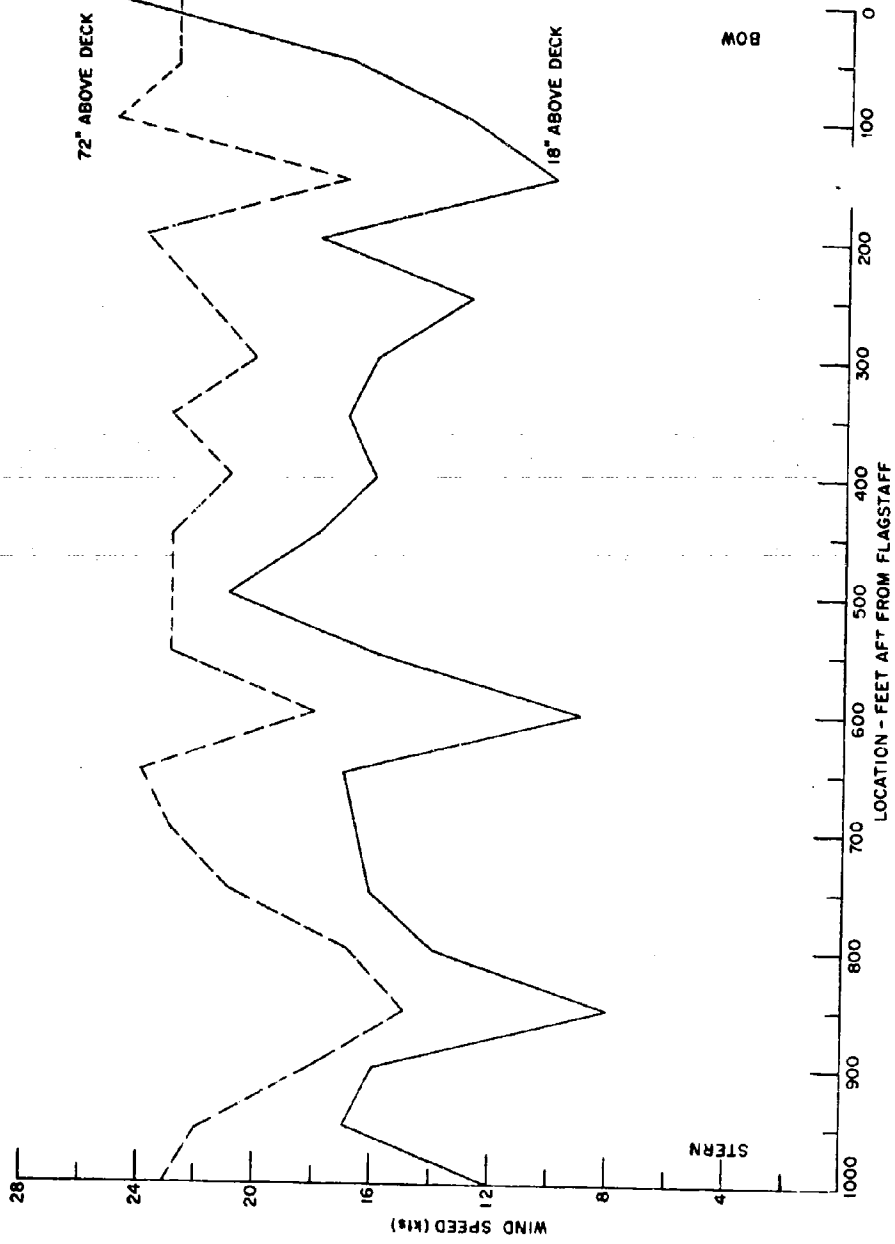

Fig. 8 - Profile of wind speeds down the length of the deck centerline at 18 in. and 72 in. levels

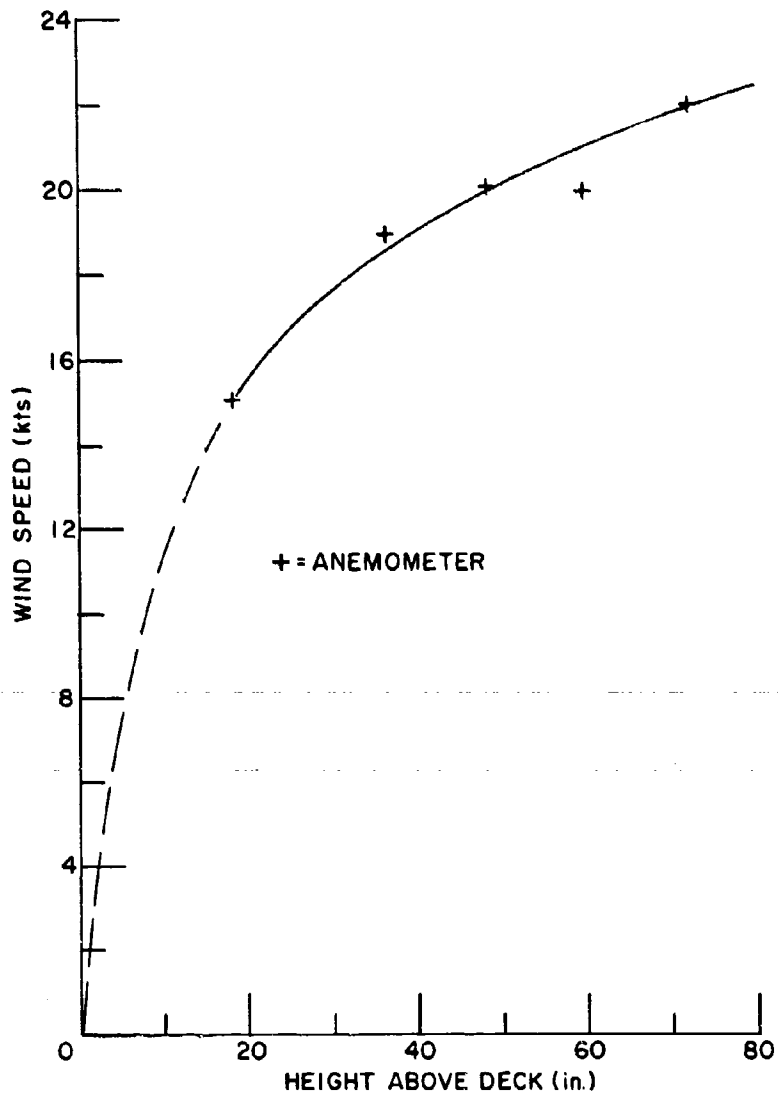

Fig. 9 - Variation in wind speed as a function of height above deck based on an average of centerline values



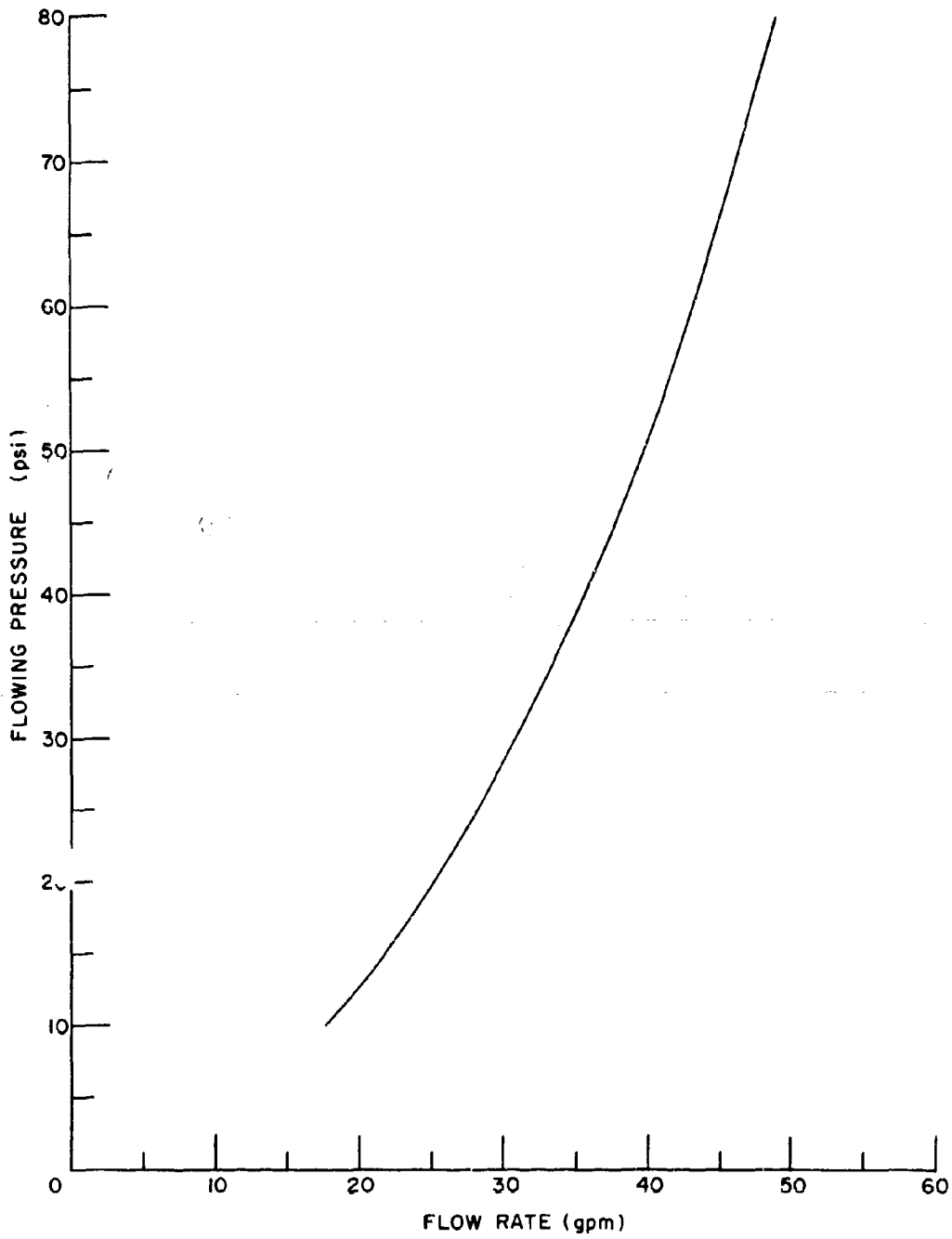

Fig. 11 - Discharge flow rate of the Type "S" nozzle as a function of discharge pressure (Source: Grinnell Co.).

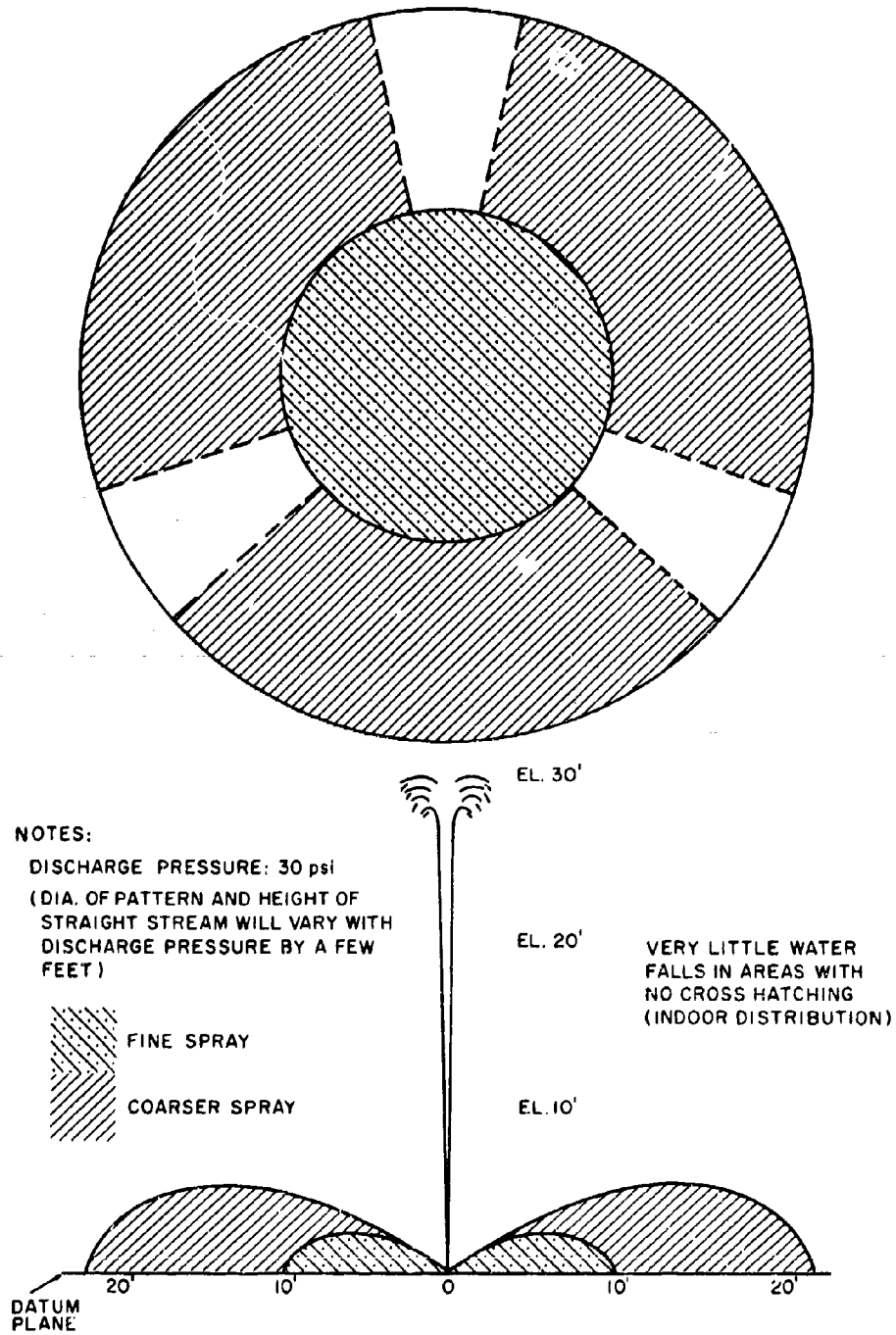

Fig. 12 - Vertical and horizontal discharge characteristics of the Type "S" nozzle (Source: Grinnell Co.).

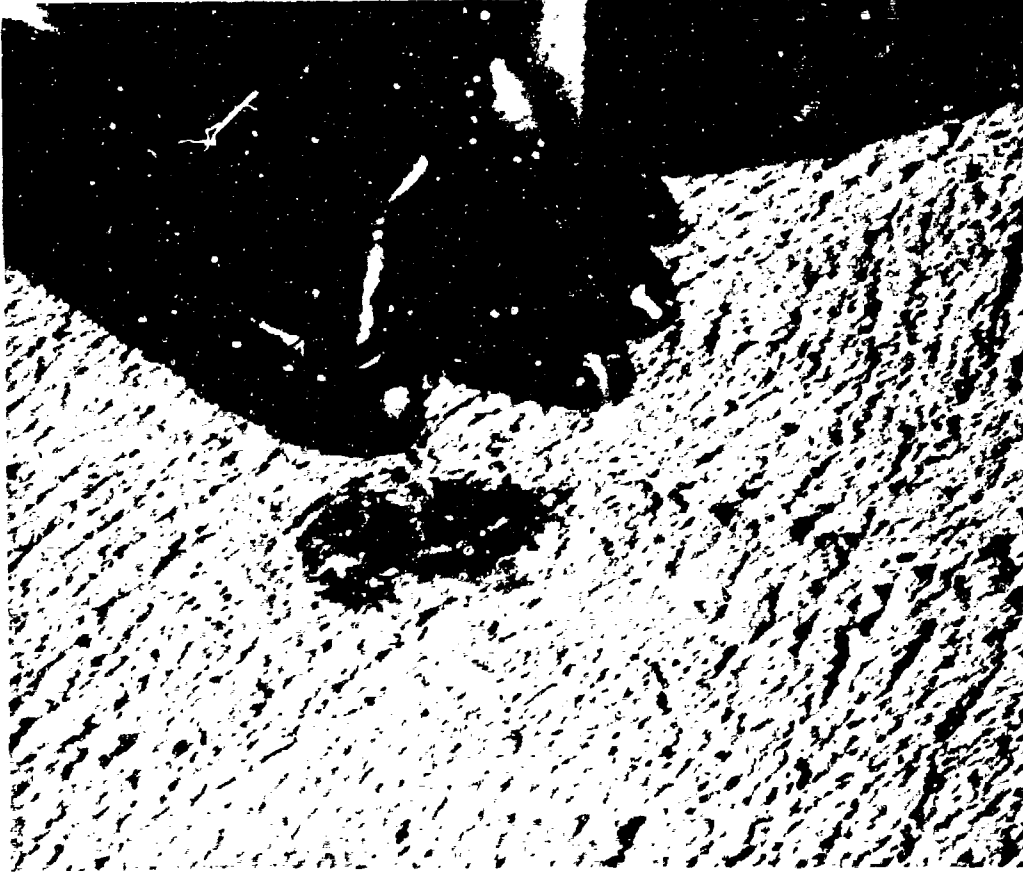

Fig. 13 - Typical installation of a Type "S" nozzle in flight deck



Fig. 14 - One foot square collection pans used for determining water patterns on the deck secured against high wind conditions

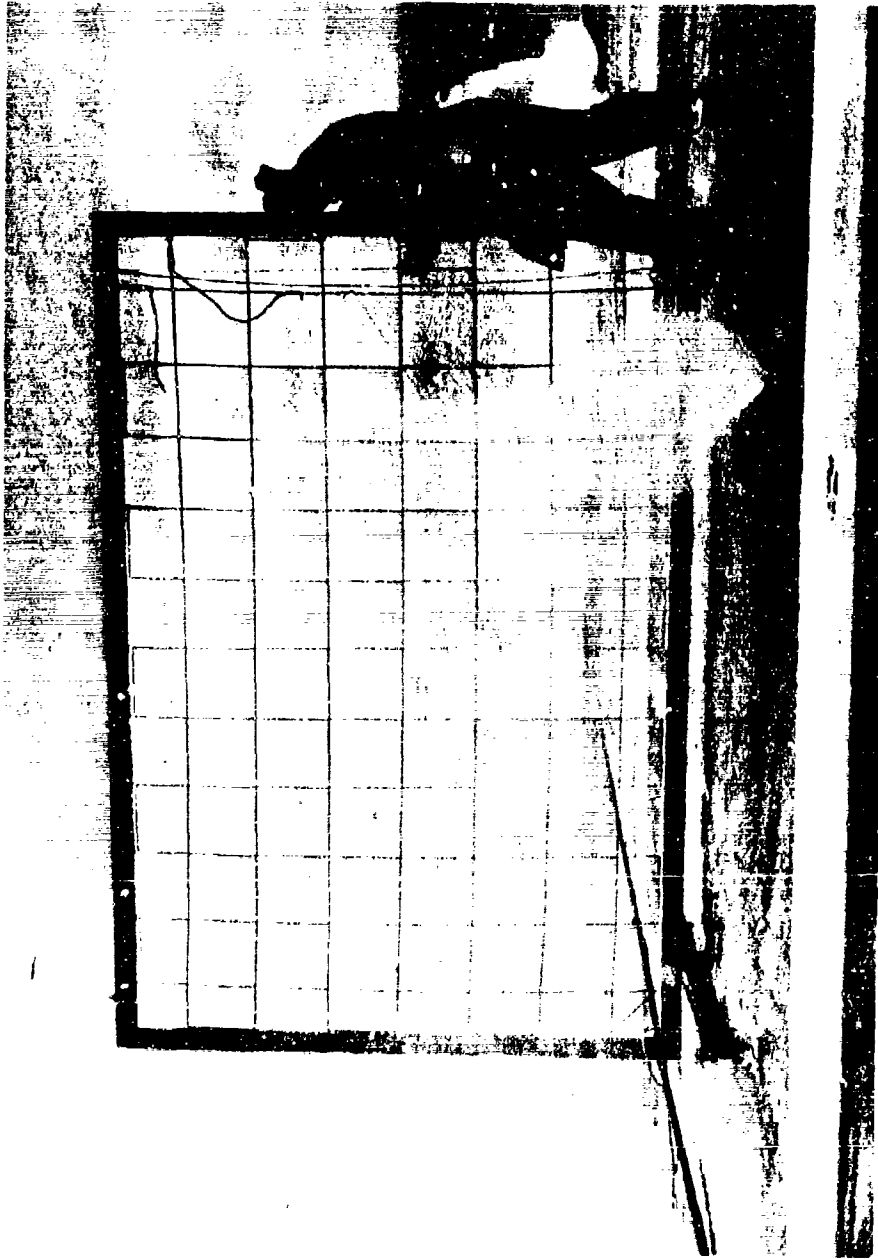

Fig. 15 - Flush-deck nozzle discharge against the witness panel for measurement of wind-blown pattern

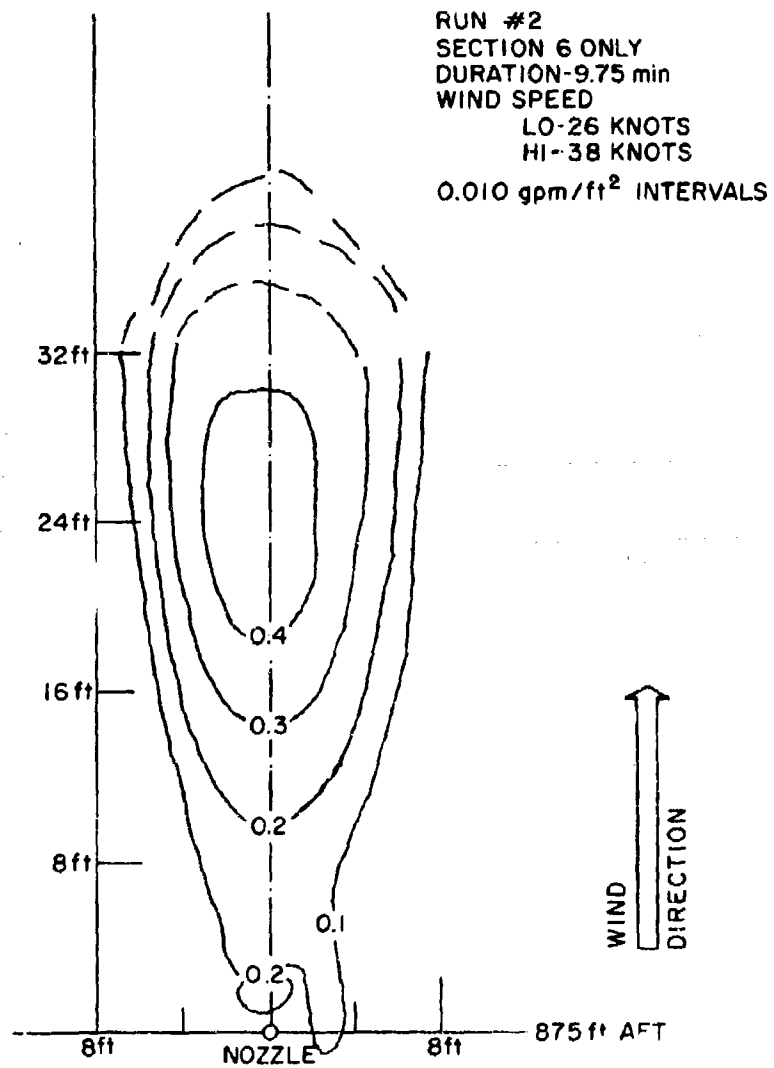

Fig. 16 - Water distribution application pattern around  
 a single flush-deck nozzle with a 30 knot wind

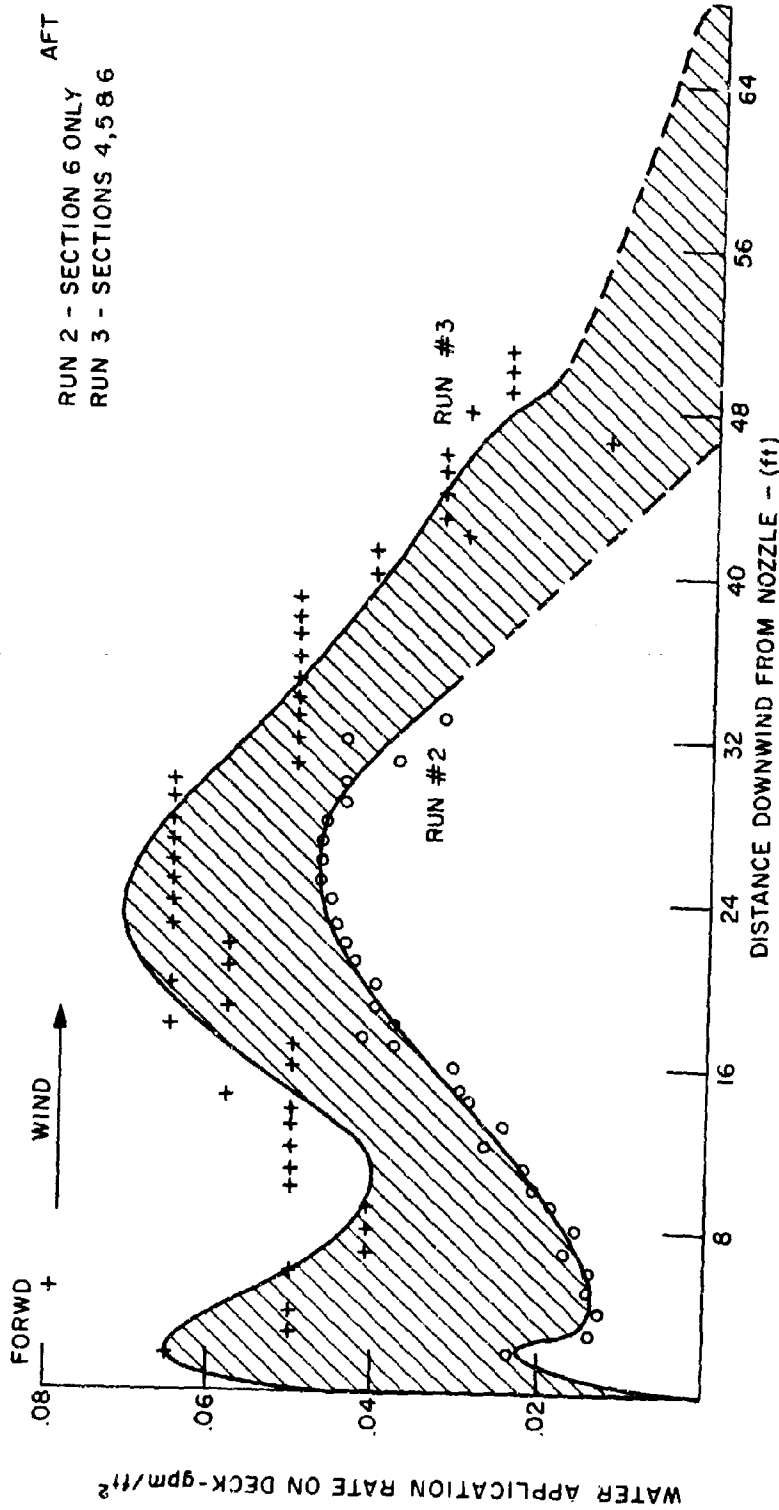

Fig. 17 - Comparison of water distribution-application patterns of a flush-deck nozzle showing the contribution of forward nozzles

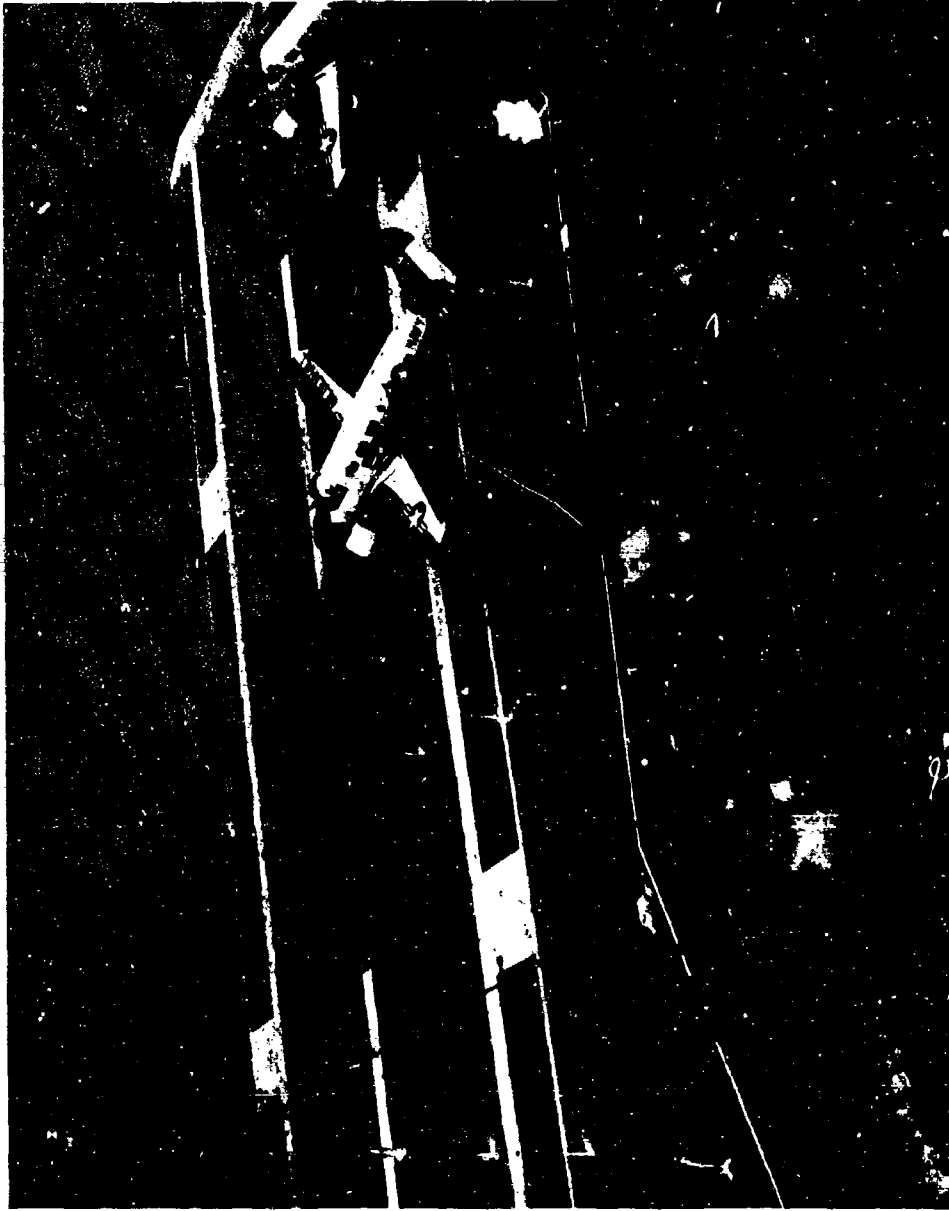

Fig. 18 - View of Section 6 of the 'washdown' system operating in a 30 knot wind



Fig. 19 - Deck-level view of Section 6 operating under a 30 knot wind condition

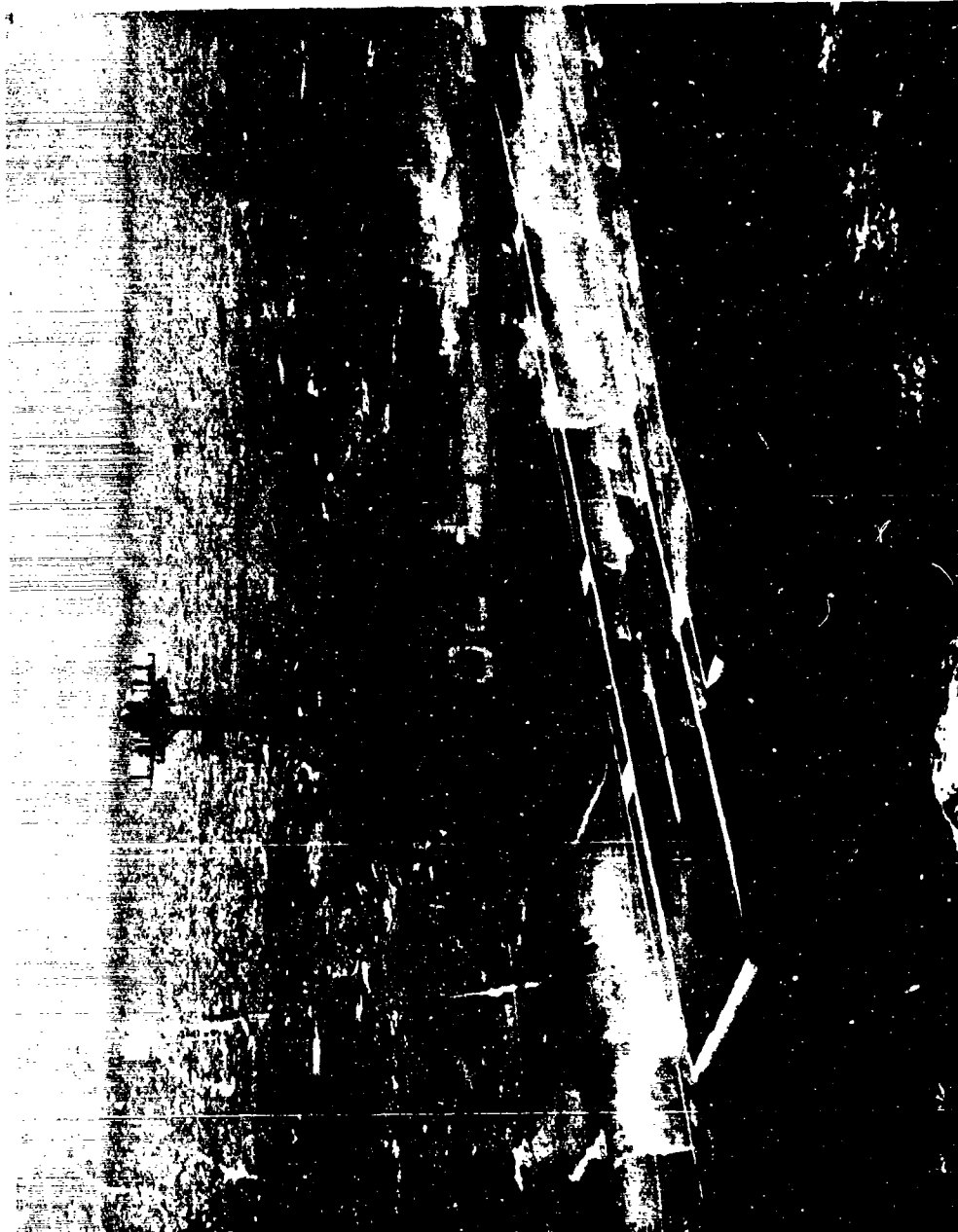

Fig. 20 View of Sections 4 and 5 being operated with a 30 knot wind.  
Note the lack of range of the 'cannon' nozzles.



Fig. 21 - Port side view of Sections 4, 5, and 6 during operation with 30 knot wind



Fig. 22 - Starboard view of Sections 4, 5, and 6 during operation with 30 knot wind



Fig. 23 - Pattern and range performance of 120 gpm nozzles mounted at opposite edges of flight deck. Lack of center coverage is apparent.



Fig. 24 - Rigging the simulated Zuni rocket constructed of sponges under the wing of the C-45 aircraft

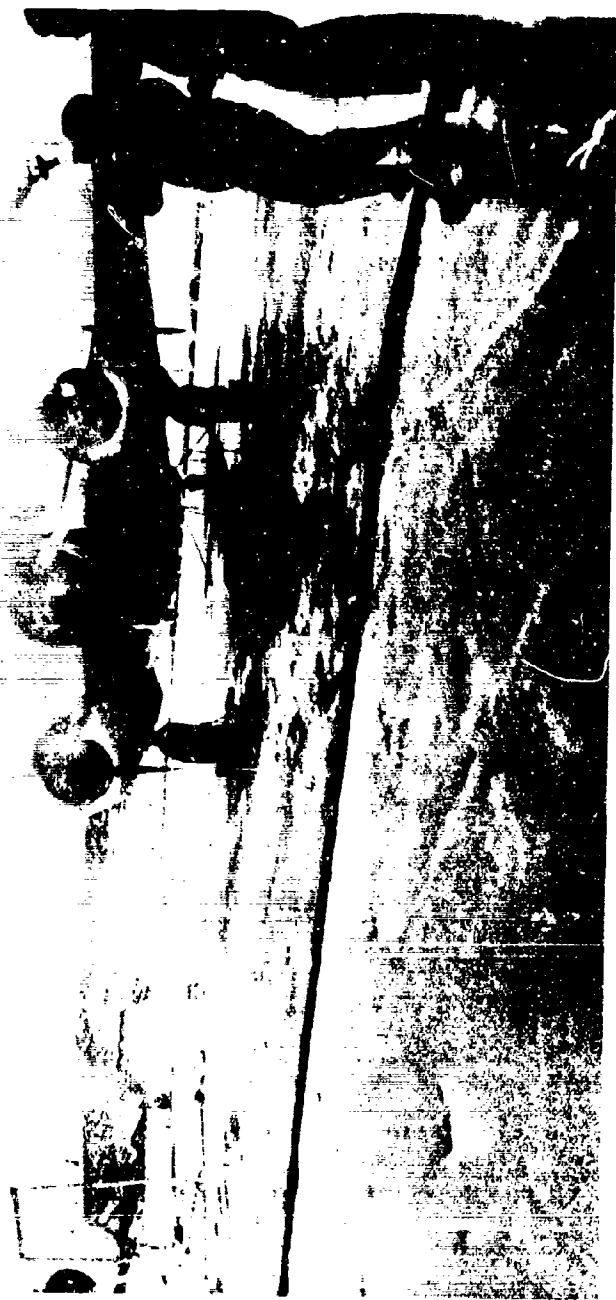

Fig. 25 - Discharge of agents from the TBFFU nozzles at 90 degrees to a 30 knot wind

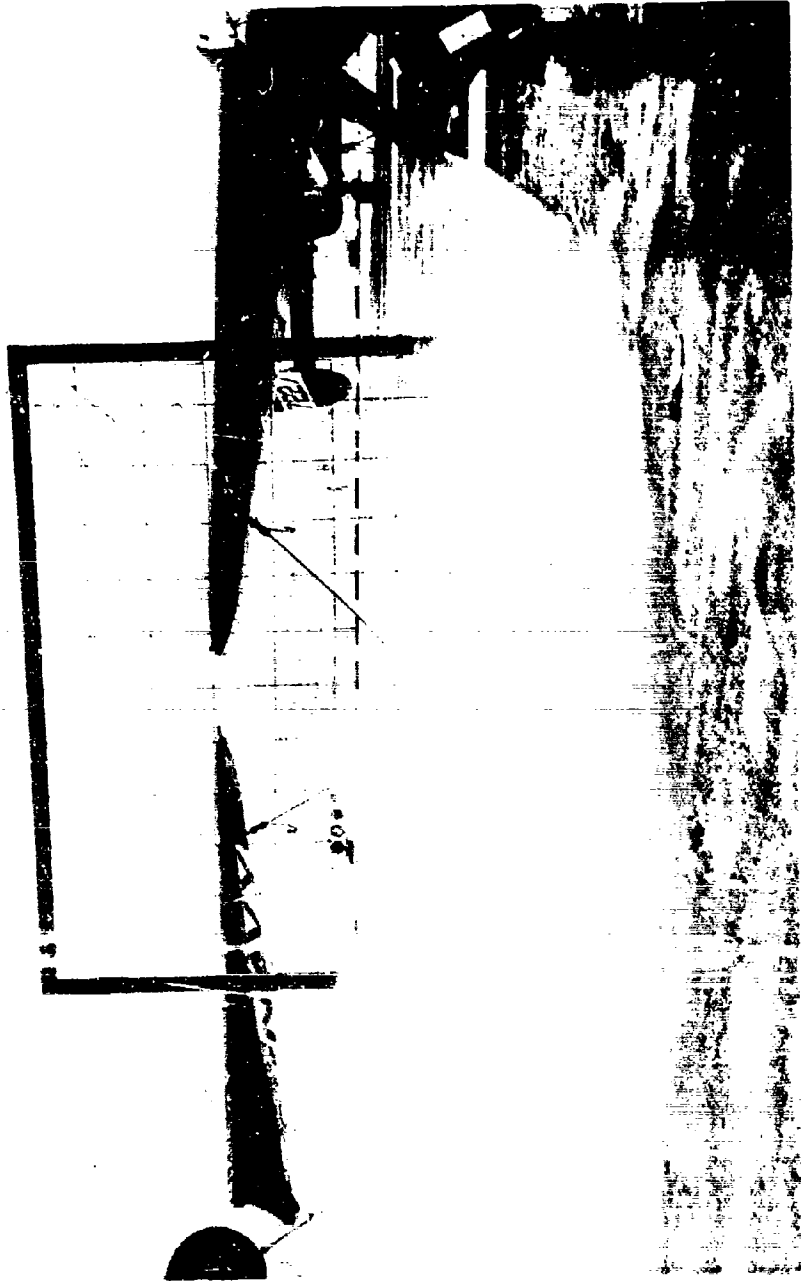

Fig. 26 - Discharge of 30-lb portable P-K-P extinguisher in a down-wind direction in front of witness panel



Fig. 27 - "Light Water", application from boom of UH-2B helicopter with a 30 knot wind over the deck

The subject of this report is the application of the boom of a UH-2B helicopter to the application of water to the deck of a ship in a 30 knot wind. The subject of this report is the application of the boom of a UH-2B helicopter to the application of water to the deck of a ship in a 30 knot wind.

UNCLASSIFIED

Security Classification

DOCUMENT CONTROL DATA - R & D

(Security classification of title, body of abstract and indexing annotation must be entered here. Overall report is classified)

1. ORIGINATING ACTIVITY (Corporate author) Naval Research Laboratory Washington, D.C. 20390		2a. REPORT SECURITY CLASSIFICATION UNCLASSIFIED	
		2b. GROUP	
3. REPORT TITLE FIRE EQUIPMENT TESTS ABOARD THE CVA-62 RELATED TO IMPROVED AIRCRAFT CARRIER SAFETY			
4. DESCRIPTIVE NOTES (Type of report and inclusive dates) An interim report on one phase of the problem.			
5. AUTHOR(S) (First name, middle initial, last name) H. B. Peterson, R. L. Tuve, E. J. Jablonski, R. R. Neill, A. W. Bertschy, and R. L. Gipe			
6. REPORT DATE 30 January 1968		7a. TOTAL NO. OF PAGES 61	7b. NO. OF REFS 0
8a. CONTRACT OR GRANT NO. NRL Problem C05-19		9a. ORIGINATOR'S REPORT NUMBER(S) NRL Memorandum Report 1851	
b. PROJECT NO. SF 015-07-02-3350, S-4624-006		9b. OTHER REPORT NO(S) (Any other numbers that may be assigned this report)	
c.			
d.			
10. DISTRIBUTION STATEMENT This document has been approved for public release and sale; its distribution is unlimited.			
11. SUPPLEMENTARY NOTES		12. SPONSORING MILITARY ACTIVITY Department of the Navy (Naval Ship Systems Command) Washington, D. C. 20360	
13. ABSTRACT A series of tests were conducted at sea aboard the USS INDEPENDENCE (CVA-62) for the purpose of evaluating the application of the twinned agents, "Light Water" - Purple-K-Powder, from the Twin Ball Fire Fighting Unit, application of "Light Water" from a helicopter, and P-K-P from portable extinguishers. Also studied were the characteristics of the NBC "washdown" nozzles as possible basis for the introduction of a "Light Water" based installed fire protection system for the flight deck. Wind speeds and patterns were measured at various heights above the deck to establish their role in fire fighting operations. The major portion of the work was done under 30 knot winds characteristic of the wind speed during aircraft launch and recovery and representing the most severe conditions for extinguishing fires. The air flow over the deck below the 6 ft level was found to be laminar in character with marked diminishment in speed at levels near the deck. Thus, the detrimental effects of wind on the discharge patterns of fire extinguishing agents was not serious in the down-wind direction but did severely limit the cross-wind agent reach. The water distribution pattern from the "washdown" nozzles offers good potential as a base for a fire fighting system which with "Light Water" will offer both fire extinguishing and ordnance cooling capabilities. Average water application rate from this system is 0.03 gpm/ft <sup>2</sup> deck area, although the tests proved the wind-blown patterns were very uneven. Previous shore-based fire tests have shown JP-5 fires can be readily extinguished at this application rate of "Light Water" spray. Simulated ordnance made of sponges demonstrated that			

DD FORM 1 NOV 65 1473 (PAGE 1)

S/N 0101-807-6801

UNCLASSIFIED

Security Classification

UNCLASSIFIED

Security Classification

14 KEY WORDS	LINK A		LINK B		LINK C	
	ROLE	WT	ROLE	WT	ROLE	WT
Aircraft carrier safety USS INDEPENDENCE (CVA-62) Fire extinguishing agents Helicopter application of "Light Water" Application of Purple-K-Powder from portable extinguishers NBC "washdown" nozzles High Capacity Fog Foam System Evaluating tests						
<p>water spray concentrations of 0.015 gpm were reaching each square foot of exposed munitions surface area. This is equivalent to absorbing about 150 BTU/min/ft<sup>2</sup>.</p> <p>The discharge of water nozzles mounted along the edge of the flight deck and directed inboard was found to be highly deflected by the wind and will present a problem in properly designing a system for those carriers not already fitted with flush-deck nozzles. Additional testing on the pattern, flow, and angle of discharge will be required in order to obtain satisfactory results.</p> <p>Extreme wind deflection of "Light Water" applied from the boom of the UH-2B helicopter dispersed the stream and made aiming to the site of the fire difficult. These and other helicopter operational problems lead to the recommendation that this method not be considered further for carriers.</p> <p>Operation of two of the High Capacity Fog Foam System stations revealed problems in getting them into action within the desired time period of 30 sec. Their foam proportioning was found to be erratic but usually on the rich side. Foam concentrate replenishment rates were inadequate.</p>						