

AD 665398



LRTP MATHEMATICAL MODEL BROCHURE

CAL No. VQ-2044-H-3

Prepared for:

**U. S. ARMY MATERIEL COMMAND
Contract DA-49-186 AMC-237(X)
30 October 1965**

FEB 27 1968

13A

CORNELL AERONAUTICAL LABORATORY, INC.
Buffalo 21, N.Y.



LRTP MATHEMATICAL MODEL BROCHURE

CORNELL AERONAUTICAL LABORATORY
REPORT NO. VQ-2044-H-3
30 OCTOBER 1965

Approved by: *Floyd D. Hill*
HEAD, WASHINGTON PROJECTS DEPARTMENT

Prepared for: U. S. ARMY MATERIEL COMMAND
CONTRACT DA-49-186 AMC-237(X)

CONTENTS

| | <u>Page No.</u> |
|---|-----------------|
| 1. INTRODUCTION | 1 |
| 2. MATHEMATICAL DESCRIPTION OF THE LRTP CHOICE MODEL | 1 |
| 2.1 Structural Relationships | 1 |
| 2.2 Mathematical Description | 4 |
| 2.2.1 Problem Formation | 4 |
| 2.2.2 The MBPA Configuration Set | 5 |
| 2.2.3 The Expected Technical Value of an MBPA Configuration | 6 |
| 2.2.4 The Annual Cost of a Configuration for an MBPA | 7 |
| 2.2.5 The Annual Monetary Quota Cost of a Configuration for an MBPA | 8 |
| 2.2.6 The Expected Cost of a Configuration for an MBPA | 9 |
| 2.3 Method of Approximation | 9 |
| 2.3.1 Description | 10 |
| 2.4 Summary of Symbols | 11 |
| 2.4.1 Subscripts | 11 |
| 2.4.2 Inputs | 12 |
| 2.4.3 Auxiliary Symbols | 13 |
| 2.4.4 Outputs | 14 |
| 3. COMPUTER PROGRAM FOR LRTP MODEL | 14 |
| 3.1 Description of the Program | 15 |
| 3.1.1 The Inputs | 15 |
| 3.1.2 The LRTP Program | 16 |

| | <u>Page No.</u> |
|--------------------------------------|-----------------|
| 3.2 Definition of TABLES and ITEMS | 36 |
| 3.3 Flow of LRTP Program | 38 |
| 3.4 Fortran Listing | 45 |
| 3.5 Debugging Log | 56 |
| 4. NUMERICAL EXAMPLES | 57 |
| 4.1 Generation of Hypothetical Data | 57 |
| 4.2 Computer Runs | 59 |
| APPENDICES: I-INPUT CARD DESCRIPTION | I-1 |
| II-SAMPLE COMPUTER OUTPUT | II-1 |

1. INTRODUCTION

This brochure contains a technical description of the LRTP Choice Model derived in Cornell Aeronautical Report No. VQ-2044-H-2, "The LRTP Process as it Relates to the U. S. Army Materiel Command". The brochure is self-contained in that the technical aspects may be read and understood without referring to the above report.

This brochure is divided into three sections, excluding the Introduction. Section 2 gives a mathematical description of the model. Section 3 contains a description of the computer program which includes flow charts, a FORTRAN listing and a debugging log. Section 4 contains several numerical examples of program outputs using hypothetical input data.

2. MATHEMATICAL DESCRIPTION OF THE LRTP CHOICE MODEL

This section presents a mathematical description of the LRTP Choice Model to the extent necessary for programming the model.

The description is given in four parts. Section 2.1 provides a description of the relationships between the conceptual elements generated by the LRTP planning process. Section 2.2 gives a mathematical description of the model and Section 2.3 gives the procedure used to approximate solutions. Section 2.4 contains a summary of symbols.

2.1 Structural Relationships

The choice problem begins with a given set of Major Barrier Problem Areas (MBPA's) where each MBPA has been derived from one or more Research Development Objectives (RDO's). Accompanying each MBPA is a binary statement as to whether or not a minimum research and

development work effort must be funded. Also, each MBPA has three numerical values associated with it. The first is the estimated expected probability that an RDO will appear at some future date in the form of a Qualitative Materiel Development Objective (QMDO) or a Qualitative Materiel Requirement (QMR). The second is the estimated expected probability that the MBPA will be encountered in a Technical Approach given that an RDO containing the MBPA appears in the form of a QMDO or QMR. The third value associated with each MBPA is its estimated essentiality relative to other MBPA's. The essentiality is assumed to be derived from priorities assigned to RDO's.

In order to overcome the MBPA's, one or more alternative Tasks (TK's) are proposed for each MBPA; any Task proposed for an MBPA will overcome it if successful. A Task is defined in terms of a sequence of annual Work Efforts (WE's), and associated with each annual Work Effort is an estimated conditional probability of success, estimated cost and a Monetary Quota to which it is assigned. A Monetary Quota represents a Field Establishment assigned to conduct the work. A Task is said to be successful if all of the annual Work Efforts associated with the Task are successful.

The above relationships are indicated in Figure 2-1.

The problem is to determine possible combinations of Tasks for funding (and consequently those not to fund) that maximize the expected Technical Value of the LRTP program and satisfy given minimum costs assigned the Monetary Quotas and MBPA minimum Work Effort statements.

Henceforth, a combination of Tasks will be called a Configuration.

MAJOR BARRIER
PROBLEM AREAS

1. Binary statement concerning minimum funding
2. Probability of appearance in RDO
3. Probability that it will be encountered
4. Essentiality

PROPOSED
ALTERNATIVE
TASKS

PROBLEM:
Determine combinations of Tasks for possible funding subject to constraints

SEQUENCES OF
ANNUAL WORK
EFFORTS

1. Probability of success
2. Cost
3. Monetary Quota

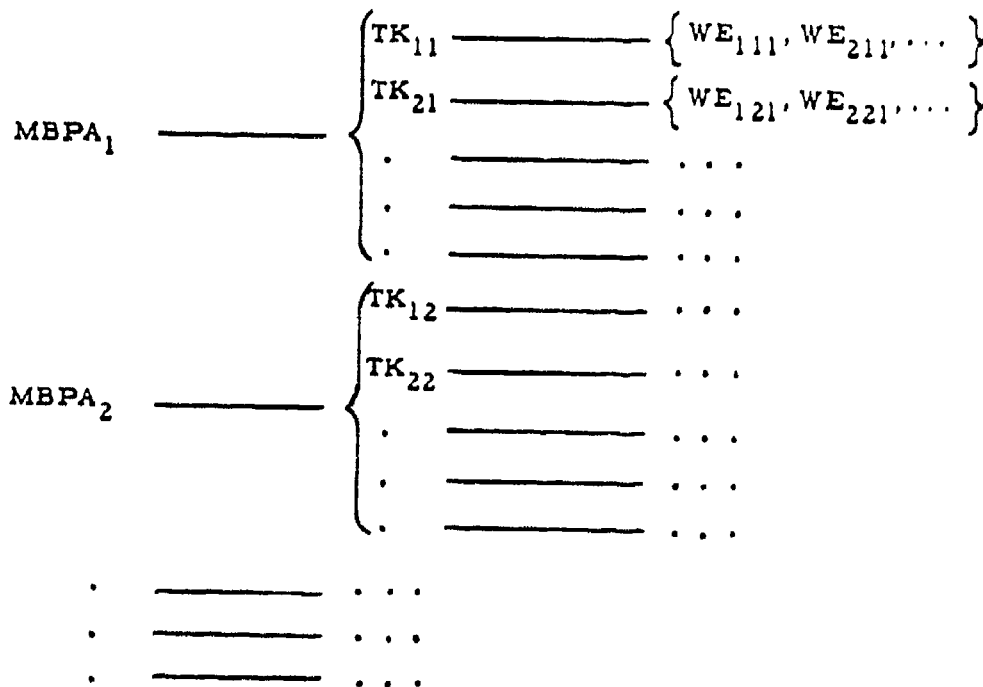

Figure 2-1. Structural Relationships

2.2 Mathematical Description

2.2.1 Problem Formation

Let R denote the Configuration set where R is of the form:

$$R(r) = \prod_{k=1}^a R_k(r_k) \text{ (direct product set)}$$

where a Configuration $r \in R$ consists of an ordered a -tuple $(r_1, r_2, \dots, r_k, \dots, r_a)$ of Configurations, one for each MBPA. Defined on the Configuration set is a function $V(r)$ called the expected Technical Value of a Configuration. Also defined on the Configuration set are three cost functions. The first cost function $C(r)$ is called the Annual Cost of a Configuration and is expressed as a single value. The second cost function $Q(r)$ is called the Annual Monetary Quota Cost of a Configuration and is expressed as an ordered b -tuple $(q_1, q_2, \dots, q_n, \dots, q_b)$ of annual costs, one for each Monetary Quota. The third cost function $E(r)$ is called the Expected Cost of a Configuration and is expressed as a single value.

The expected Technical Value and Costs of an LRTP Configuration are given by:

$$(1) \quad V(r) = \sum_{k=1}^a V_k(r_k)$$

$$(2) \quad C(r) = \sum_{k=1}^a C_k(r_k)$$

$$(3) \quad Q(r) = \sum_{k=1}^a Q_k(r_k)$$

$$(4) \quad E(r) = \sum_{k=1}^a E_k(r_k)$$

where

$V_k(r_k) =$ the expected Technical Value of a Configuration for the k-MBPA

$C_k(r_k) =$ the Annual Cost of a Configuration for the k-th MBPA

$Q_k(r_k) =$ the Annual Monetary Quota Cost of a Configuration for the k-th MBPA

$E(r_k) =$ the Expected Cost of a Configuration for the k-th MBPA.

Given the above relationships and a Monetary Quota constraint F , where F is an ordered b-tuple $(f_1, f_2, \dots, f_n, \dots, f_b)$ of minimum funds, one for each Monetary Quota and binary statements h_k , one for each MBPA, the problem is to determine

$$\max \{V(r) \mid r \in R\}$$

subject to

$$Q(r) \geq F \quad (q_n \geq f_n \text{ for all } n)$$

and the conditions imposed by the binary statements.

2.2.2 The MBPA Configuration Set

A Configuration for the k-th MBPA $r_k \in R_k$ consists of an ordered d_k -tuple of the form $(r_{1k}, r_{2k}, \dots, r_{jk}, \dots, r_{d_k k})$ where r_{jk} can take on one of two values, say either 1 or 0;

$r_{jk} = 1$ denotes the j-th Task proposed for the k-th MBPA is represented in the r_k Configuration

$r_{jk} = 0$ denotes the j-th Task proposed for the k-th MBPA is not represented in the r_k Configuration.

Let

$h_k =$ a binary statement as to whether or not a minimum research and development work effort for the k-th MBPA must be funded

where

$h_k = 1$ denotes the k-th MBPA must be funded

$h_k = 0$ denotes the k-th MBPA does not necessarily have to be funded.

Given $h_k = 1$, the Configuration set R_k for the k-th MBPA consists of all Configurations r_k that have at least one Task represented in them. Given $h_k = 0$, the Configuration set R_k for the k-th MBPA consists of all possible combinations where there are 2^k combinations (Configurations) represented in the set.

2.2.3 The Expected Technical Value of an MBPA Configuration

Let

$P_{ijk} =$ estimated conditional probability of success of the i-th WE of the j-th Task proposed for the k-th MBPA, $i=1, 2, \dots, m_{jk}$

$U_k =$ expected probability that an RDO will appear at some future date and contain the k-th MBPA

$w_k =$ estimated expected probability that the k-th MBPA will be encountered in a Technical Approach given that an RDO containing the MBPA appears at some future date

$u_k =$ number of RDO's that the k-th MBPA is associated with

$s =$ total number of RDO's.

Then, the estimated probability U_k is given by

$$(5) U_k = u_k/s.$$

The probability of success $P_{jk}(r_{jk})$ of the j -th Task proposed for the k -th MBPA is given by

$$(6) P_{jk}(r_{jk} = 1) = \prod_{i=1}^{m_{jk}} P_{ijk'}$$

$$(7) P_{jk}(r_{jk} = 0) = 0.$$

The probability that the j -th Task proposed for the k -th MBPA fails $N_{jk}(r_{jk})$ is given by

$$(8) N_{jk}(r_{jk}) = 1 - P_{jk}(r_{jk})$$

The probability that at least one Task is successful $S_k(r_k)$ in overcoming the k -th MBPA is given by

$$(9) S_k(r_k) = 1 - \prod_{j=1}^{d_k} N_{jk}(r_{jk}).$$

Finally, the expected Technical Value of a Configuration for the k -th MBPA is given by

$$(10) V_k(r_k) = U_k w_k e_k S_k(r_k).$$

2.2.4 The Annual Cost of a Configuration for an MBPA

Let

c_{ijkn} = estimated cost of the i -th annual Work Effort of the j -th Task proposed for the k -th MBPA and assigned to the n -th Monetary Quota.

The annual cost of the j-th Task $C_{jk}(r_{jk})$ proposed for the k-th MBPA is given by

$$(11) C_{jk}(r_{jk} = 1) = c_{1 jkn}$$

$$(12) C_{jk}(r_{jk} = 0) = 0$$

and the Annual Cost $C_k(r_k)$ of a Configuration for the k-th MBPA is given by

$$(13) C_k(r_k) = \sum_{j=1}^{d_k} C_{jk}(r_{jk})$$

2.2.5 The Annual Monetary Quota Cost of a Configuration for an MBPA

The annual Monetary Quota Cost $Q_{jk}(r_{jk})$ of the j-th Task proposed for the k-th MBPA is given by

$$(14) Q_{jk}(r_{jk}=1) = (y_1, y_2, \dots, y_n, \dots, y_b)$$

where

$$y_n = \delta c_{1 jkn}$$

$$\delta = \begin{cases} 1 & \text{for } n = n' \\ 0 & \text{otherwise} \end{cases}$$

and

$$(15) Q_{jk}(r_{jk} = 0) = 0 \quad (y_n = 0 \text{ for all } n)$$

The Monetary Quota Cost $Q_k(r_k)$ of a Configuration for the k-th MBPA is given by

$$(16) Q_k(r_k) = \sum_{j=1}^{d_k} Q_{jk}(r_{jk})$$

2.2.6 The Expected Cost of a Configuration for an MBPA

The expected cost $E_{jk}(r_{jk})$ of the j-th Task associated with the k-th MBPA is given by

$$(17) E_{jk}(r_{jk} = 1) = c_{1 jkn} + \sum_{i=2}^{m_{jk}} P_{ijk} c_{ijkn}$$

$$(18) E_{jk}(r_{jk} = 0) = 0.$$

The expected cost $E_k(r_k)$ of a Configuration for the k-th MBPA is given

$$(19) E_k(r_k) = \sum_{j=1}^{d_k} E_{jk}(r_{jk}).$$

2.3 Method of Approximation

The purpose of this section is to list the steps employed in determining

$$\max \{V(r) \mid r \in R\}$$

subject to

$$Q(r) \geq F$$

and the MBPA binary work effort statements.

The methodology presented herein is similar to that described in Cornell Aeronautical Laboratory Report No. VQ-1887-H-1, May 19, 1964. As indicated in the report, the method is one of approximation and the results are not necessarily true maximums.

2.3.1 Description

The steps employed to approximate the set of Configurations with maximum Expected Technical Value subject to Monetary Quota Costs and MBPA binary work effort statements may briefly be described as follows:

1. Set $r_k = 1$. ($r_k = 1$ denotes an MBPA Configuration consisting of all Tasks proposed for the MBPA.)

2. Compute $V_k(r_k)$, $E_k(r_k)$.

3. For each Task compute

$$\frac{\Delta V_{jk}}{\Delta E_{jk}} = \frac{V_k(r_k) - V_k(r_k^j)}{E_k(r_k) - E(r_k^j)}$$

where r_k^j denotes the r_k Configuration without the j -th Task of the k -th MBPA.

4. Rank the Tasks in order of increasing $\Delta V_{jk}/\Delta E_{jk}$, $j_1, j_2, \dots, j_{x+1}, \dots$; $x=0, 1, 2, \dots$

5. Set $r=1$ ($r=1$ denotes the Configuration consisting of all proposed Tasks.)

6. Determine if $Q(r) \geq F$. If the statement is true, proceed to the next step. If the statement is false, stop computation.

7. Set $x=0$.

8. Determine if $Q(r^{j_{x+1}}) \geq F$ where $r^{j_{x+1}}$ denotes the r -th Configuration with the j_{x+1} Task removed. If the statement is true proceed to the next step; if false, go to step 11.

9. If $h_k = 1$, determine if at least one Task for the k -th MBPA is represented in the Configuration $r^{j_{x+1}}$. If yes, proceed to the next step, if not, go to step 11.

10. Set $r^{j_{x+1}} = r+1$ and $r = r^{j_{x+1}}$.

11. Set $x = x+1$ and go to step 8.

The above procedure is repeated until all Tasks in the rank ordering have been considered.

2.4 Summary of Symbols

2.4.1 Subscripts

k = identification number of a Major Barrier Problem Area. $k = 1, 2, \dots, a$.

j = identification number of a Task. $j = 1, 2, \dots, d_k$.

i = identification number of an Annual Work Effort.
 $i = 1, 2, \dots, m_{jk}$.

n = identification number of a Monetary Quota.
 $n = 1, 2, \dots, b$.

2.4.2 Inputs

FOR EACH MAJOR BARRIER PROBLEM AREA (MBPA)

h_k = a binary statement as to whether or not a minimum research and development work effort for the k-th MBPA must be funded

where

$h_k=1$ denotes the k-th MBPA must be funded.

$h_k=0$ denotes the k-th MBPA does not necessarily have to be funded.

u_k = number of Research Development Objectives (RDO's) that the k-th MBPA is associated with.

w_k = estimated expected probability that the k-th MBPA will be encountered in a Technical Approach given that an RDO containing the MBPA appears at some future date.

e_k = the Technical Essentiality assigned to the k-th MBPA.

FOR EACH ANNUAL WORK EFFORT (WE)

p_{ijk} = estimated conditional probability of success of the i-th WE of the j-th Task proposed for the k-th MBPA.

c_{ijkn} = estimated cost of the i-th WE of the j-th Task proposed for the k-th MBPA and assigned to the n-th Monetary Quota

OTHER INPUTS

n = total number of RDO's
 F = minimum amount of funds that must be allocated to each Monetary Quota where F is an ordered b-tuple $(f_1, f_2, \dots, f_n, \dots, f_b)$ funds, one for each Monetary Quota.

2.4.3 Auxiliary Symbols

$V_k(r_k)$ = expected Technical Value of a Configuration for the k-th MBPA

$C_k(r_k)$ = the Annual Cost of a Configuration for the k-th MBPA

$Q_k(r_k)$ = the Annual Monetary Quota Cost of a Configuration for the k-th MBPA

$E_k(r_k)$ = the Expected Cost of a Configuration for the k-th MBPA

U_k = expected probability that an RDO will appear at some future date and contain the k-th MBPA

$P_{jk}(r_{jk})$ = probability of success of the j-th Task proposed for the k-th MBPA

$N_{jk}(r_{jk})$ = probability that the j-th Task proposed for the k-th MBPA fails

$S_k(r_k)$ = probability that at least one Task included in the r_k Configuration is successful

C_{jk} = annual cost of the j-th Task proposed for the k-th MBPA

$Q_{jk}(r_{jk})$ = annual Monetary Quota Cost of the j-th Task proposed for the k-th MBPA

$E_{jk}(r_{jk})$ = the expected cost of the j-th Task proposed for the k-th MBPA.

2.4.4 Outputs

r = identification number of a Configuration. $r=1, 2, \dots$

(j, k) = identification of Tasks included in the r-th Configuration

$V(r)$ = the expected Technical Value of the r-th Configuration

$C(r)$ = the Annual Cost of the r-th Configuration

$\Delta V(r)$ = the difference between the expected Technical Values of the r-th and r-1 Configurations

$\Delta C(r)$ = the difference between the Annual Costs of the r-th and r-1 Configurations

$Q(r)$ = the Annual Monetary Quota Cost of the r-th Configuration.

3. COMPUTER PROGRAM FOR LRTP MODEL

This section contains a description of the computer program which processes data for the LRTP model. The inputs and the outputs of the program are illustrated and the method of organizing information which controls the program's operation is presented.

The computer program has been written in the FORTRAN IV language. It is prepared for operation under the control of IBSYS, the operating system used for several IBM computers (work on this project was conducted at a 7090-1401 computing center).

3.1 Description of the Program

3.1.1 The Inputs

There are three categories of inputs that affect the program; those that control IBSYS, those that control the program and those that provide data to the program. These three types of inputs are provided on four kinds of punched cards: (1) IBSYS Control, (2) Program Control, (3) Data, and (4) Special. These cards are described in the following paragraphs and illustrated in Appendix I and Figures 3-1 through 3-6.

3.1.1.1 IBSYS Control Cards

IBSYS is the system which exercises control over the operations conducted by the computer and equipment attached to it. In order for the LRTP Program to operate and to have data for its computations, IBSYS must do these things: (1) Arrange MBPA and WE data in a prescribed order (SORT), (2) establish the arrangement of equipment for the programs use, (3) prepare the program for operation and, (4) allow the program to function.

Figure 3-1 illustrates those cards which cause SORT (a subprogram of IBSYS) to place MBPA and WE data cards in order (see section 3.1.1.3). (For a complete description of SORT see IBM Systems Reference Library File No. 7090-33, entitled, "Generalized Sorting System").

A program (using the MAP language) is used to add FILE 09 to the dictionary of files that is maintained in IBSYS. This input file (on a magnetic tape) is the sorted MBPA/WE data. Figure 3-2 illustrates this routine.

The FORTRAN IV statements which make up the program are prepared for use by an IBSYS routine called a compiler. The compiler, when the program is free of errors, works in conjunction with another IBSYS routine, called the loader, which organizes the LRTP program and lets it conduct its operations, (see Figure 3-3). NOTE: error free FORTRAN IV statements need not be compiled repeatedly. Once prepared, the "Loader" can use the LRTP program in its prepared form (a binary deck), and compiling need not be done; see Figure 3-4.

A "DATA" card is used to signal the point at which the IBSYS control system shall transfer operations to program LRTP. When LRTP has completed its computations, it relinquishes control to IBSYS (IBJOB Processor) which is directed to cease operations by the "STOP" card.

File No. 7090-27 of the IBM Systems Reference Library, entitled "IBJOB Processor" explains in detail the routines and cards mentioned above.

3.1.1.2 Program Control Cards

Three types of cards influence the operation of the LRTP program. One of them, the "END LRTP" card denotes the end of data on FILE 05, the IBSYS input file. After finding this card, the LRTP program will not seek any more data from FILE 05. For structure of the deck that contains this card see Figure 3-5.

The second kind of control card is the "WE END" card which signifies the end of data on the MBPA/WE file (FILE 09). The sorting process, mentioned in 3.1.1.1, makes this card the last one in the file. The recognition of this card signifies to the program that all data and control cards have been read in. For structure of the deck that contains this card see Figure 3-6.

The third control card may or may not be used. It is the "PRINT" card and contains 1 to 16 numbers which specify coordinates. Use it to indicate the Configuration summaries the user wishes to see. A Configuration summary lists the tasks and their costs, by monetary quota, for a coordinate. When used, the card must be placed on FILE 05, somewhere ahead of the "END LRTP" card. For structure of the deck that contains this card see Figure 3-5.

The formats of these three control cards are described in Appendix I.

3.1.1.3 Data Cards

Three kinds of data cards are provided the LRTP program. They contain information about (1) Monetary Quotas (2) Work Efforts and (3) Major Barrier Problem Areas. This information is described in Appendix I. The placement of the MQ cards is illustrated in Figure 3-5, and Figure 3-6 depicts the MBPA and WE cards as they appear in FILE 09 after the operation of SORT. These serve only to provide data to the LRTP program.

See Appendix I for the formats of these cards.

3.1.1.4 Special Cards

It is necessary that three special cards be used. The first of them, the "LRTP" card serves to identify a run of the program, and it also provides one item of information to the program, that item being a count of Research and Development Objectives. See Figure 3-5 for the structure of the deck that contains this card.

A second card, the "BCD Image" card, contains letters, digits and special characters which the program uses when making comparisons. This card must always follow the "\$DATA" card. (See Figure 3-5)

Special card three is called the "HEADER" card. It must precede the MBPA/WE cards before they are sorted. The SORT program expects a card of this kind to head the data to be sorted, see Figure 3-6. The sorted MBPA/WE data has the "HEADER" as the first file on the magnetic tape, with the data making up the second file. When processing this file, the LRTP program skips the "HEADER" file.

See Appendix I for the formats of these cards.

3.1.2 The LRTP Program

This section describes how the program reads and uses the control, data and special input cards, makes the calculations specified in the discussion of the model, and provides outputs which reflect the results of its calculations. The flow diagram in Section 3.3 illustrates the movement within the program and the FORTRAN statements in Section 3.4 provide a description of the details in each area of the program. For this section the LRTP program will be discussed from the standpoint of its inputs, its computations and its outputs.

Two categories of tables exist: those that contain data for computations and those that act as buffers (storage of input or output images). The tables of computational data are organized so that there is a relationship between the registers of different tables that pertain to the same subject; i. e., the first registers of MQID, QUOT and BUDG respectively, contain identification, quota and budget for the "MQ" with the lowest ID. Data about "MBPA's" is kept in tables MBNO, MBCD, FREQ, VALU and NODR; and tables NUTE, TECH, PSTE, COST, CSPS, MQNO and DVAL contain information on "TASK's". The MBPA and TASK tables are organized in the same fashion as the MQ tables. Tables IXTE and NOTE are used as storage for indexing data; i. e., data which enables the program to relate a TASK to its MBPA.

Input buffers, tables LPHA, INPT and sometimes IXTE, which contain the code for one card column or one print character per register. Output buffers are set up by the compiler for IOCS, the Input/Output Control System. The LRTP program in its "WRITE" statement specifies the data to be transferred from ITEMS and/or TABLES to the output buffers.

Further detailed explanation may be secured by examination of the FORTRAN listing in Section 3.4.

3.1.2.1 Input Processing

The LRTP program reads in the nine kinds of cards described in Appendix I. With the exception of the "BCD IMAGE" card and the "HEADER" card, field one is tested to ascertain the routine which is to be used to process the card. Once this selection has been made, (if unable to make a selection, see section 3.1.2.1.10) the processing goes as follows:

3.1.2.1.1 "LRTP" Card

- (a) Fields 2 and 4 are converted to integers.
- (b) Field 2 is saved in register LRTP.
- (c) Field 4 is saved in register RDOS.
- (d) The contents of the card are written on output FILE 06 (to identify the run of the program for the user).
- (e) If an error is found during the conversion, the program transfers to the error routine described in section 3.1.2.1.10, below.

3.1.2.1.2 "PRINT" Card

- (a) Up to 16 numbers will be converted to integer form and stored in registers of TABLE IOUT. The numbers must start in Column 7 and be separated by one blank column. Consecutive blank columns are interpreted as signalling the end of the control information. The last column that may be used is number 72.
- (b) Errors in converting cause the program to execute the error routine; see section 3.1.2.1.10, below.

3.1.2.1.3 "Monetary Quota" Card

- (a) Field 2 is converted to integer and stored in a register of TABLE MQID.
- (b) Field 3 is converted to a floating point number and saved in a register of TABLE QUOT.
- (c) Errors in converting these fields cause the program to execute the error routine; see section 3.1.2.1.10, below.

3.1.2.1.4 "END" Card

There is no data on this card. Its recognition, however, causes the program to arrange the MQID and QUOT tables in ascending order of MQ identification. In addition, an indicator, MBTK, is set which informs the program that all card reading is now to be done from FILE 09. Several items and tables are cleared in preparation for information from the data cards.

3.1.2.1.5 "MBPA" Card

(a) Field 2 is converted to integer and stored in a register of TABLE MBNO.

(b) Field 3 is converted from a BCD percentage to a floating point decimal and stored in a register of FREQ.

(c) Field 4 is converted to a floating point number, divided by item RDOS, multiplied by the contents of a register of FREQ (from field 3) and this product stored in this register of FREQ.

(d) Field 5 is converted to a floating point number, multiplied by the contents of FREQ (from (c) above) and the product stored in this register of FREQ.

(e) Field 6 is tested for a blank; if it contains a blank, a register of MBCD is set to blanks; otherwise, the register is set to an asterisk (*).

(f) For errors in fields 2, 3, 4 or 5, see section 3.1.2.1.10, below.

3.1.2.1.6 "WE" Card

(a) Fields 2, 3, 4 and 5 are converted to integers and stored in IDMB, IDTE, IDWE and IDMQ respectively.

(b) Fields 6 and 7 are converted to floating point and stored in PSTK and CSWE respectively. If the annual Work Effort is for the first year, the contents of field 7 are stored in CSTK, also.

(c) The program now uses the information in the items listed in (a) and (b), above, to place the following data in their proper locations in these tables:

- | | |
|----------|---|
| (1) NOTE | = Count of TASKS in a MBPA |
| (2) IXTE | = Index to TASK information for a MBPA |
| (3) NUTE | = TASK Id |
| (4) PSTE | = Product of the probabilities of success of the WORK EFFORTS in a TASK |
| (5) COST | = First year cost of a TASK |
| (6) CSPA | = Expected cost of a TASK |
| (7) MQNO | = MONETARY QUOTA which contains cost of TASK |

(d) For errors in fields 2 through 7, see section 3.1.2.1.10, below.

3.1.2.1.7 "WE END" Card

When the program finds this card, it transfers its operations from reading input data to doing the computations stated in the discussion of the LRTP MODEL in Section 2.

3.1.2.1.8 "BCD IMAGE" Card

The program must have this card prior to operating on any other input. Therefore, this card must follow the "\$DATA" card (see Figure 3-5). The first 48 characters are stored in TABLE LPHA. The data on this card must be correct and in the prescribed order, as tests for the correctness of other input data are made using "BCD IMAGE" information as the criterion.

3.1.2.1.9 "HEADER" Card

When the program begins to read from FILE 09, it executes two "read" instructions, one is to by-pass this card; the second to by-pass the "END-OF-FILE" mark. The only purpose this card serves is to satisfy the rules by which the SORT program operates.

3.1.2.1.10 Errors

An error in a piece of input information results in no computations. The program, however, prints the card which contains the error and examines all input data for illegalities, printing the cards with erroneous data.

3.1.2.2 The Calculations

There are two major areas of computation in the LRTP program. The first calculates the Technical Value of each Task and, using this TV and the Expected Cost of the Task, establishes their order of elimination. The second takes each Task, in the order that has

been set, and examines it in relation to the constraints (MBPA and MQ) that are to apply for this run of the program. When a Task is to be eliminated, the program enters the output section (see Section 3.1.2.3, below). After recording what is required in the output section, the program returns to examine the next Task in line against the constraints.

The details of the two areas of computation are as follows:

3.1.2.2.1 Technical Value

The LRTP program computes first the cost of the program being considered and then its Technical Value. Cost is the sum of the first year costs of all Tasks; Technical Value is the sum of the Technical Values of all MBPA's.

Secondly, a number which signifies relative importance is attached to each Task by computing its TV and dividing that figure by its Expected Cost (CSPS). The results are saved in the Table TECH.

3.1.2.2.2 Constraints

The Task with the least importance attached to it is examined according to rules that pertain to MBPA elimination and satisfaction of Monetary Quotas. If the Task can be eliminated without violating any MBPA or MQ rules, it is removed from the list of Tasks; and appropriate action is taken in the Output section. Whether a Task is removed or not, the next Task considered for removal is the one with the next lowest ratio of Technical Value to Expected Cost; and so on, through all Tasks.

The rules which the program contains have to do with setting a value on each Monetary Quota and not permitting the elimination of a Task to reduce a Quota below this value; and, stating whether or not all the Tasks in a MBPA may be eliminated.

3.1.2.3 The Outputs

When the LRTP program selects a Task to be eliminated, it enters the area of the program which will record for the user the pertinent information about the removal of the Task.

3.1.2.3.1 Run Information

However, three kinds of information have been written on the output file (FILE 06) prior to selecting Tasks for removal. The first of these is the Run Identification which is merely writing on the output file, the contents of the LRTP card. The second kind of information is a list of MBPA's, by ID, together with the indication of whether a MBPA can be eliminated. The third is a list of Monetary Quotas, by ID, with the number of dollars assigned to each.

The formats of these three types of output are illustrated in Figure 3-7.

3.1.2.3.2 Run Results

Illustrated in Figure 3-8 is the chart produced by the LRTP program as Tasks are eliminated. As each Task is removed, the charges in Technical Value and in Cost are printed, as well as the data which identifies the MBPA, TASK and Coordinate.

LRTP IDENTIFICATION

THE FOLLOWING IS A LIST OF MBPAS FOR THIS RUN OF THIS PROGRAM. THOSE PRECEDED BY ASTERISKS CANNOT BE

| | | | | | | | | | | |
|---------|---------|---------|---------|---------|---------|---------|---------|---------|---------|---------|
| () 1 | (*) 2 | () 3 | () 4 | () 5 | () 6 | (*) 7 | () 8 | (*) 9 | () 10 | (*) 11 |
| () 14 | () 15 | () 16 | (*) 17 | () 18 | () 19 | () 20 | () 21 | () 22 | () 23 | () 24 |
| (*) 27 | () 28 | () 29 | (*) 30 | () 31 | () 32 | () 33 | () 34 | () 35 | () 36 | (*) 37 |
| () 40 | () 41 | () 42 | () 43 | (*) 44 | () 45 | (*) 46 | () 47 | () 48 | () 49 | () 50 |
| () 53 | () 54 | (*) 55 | () 56 | () 57 | () 58 | (*) 59 | (*) 60 | () 61 | () 62 | () 63 |
| () 66 | () 67 | () 68 | () 69 | () 70 | (*) 71 | () 72 | () 73 | () 74 | () 75 | () 76 |
| (*) 79 | () 80 | () 81 | () 82 | () 83 | () 84 | () 85 | () 86 | (*) 87 | () 88 | () 89 |
| () 92 | () 93 | () 94 | () 95 | () 96 | (*) 97 | (*) 98 | () 99 | () 100 | () 101 | () 102 |
| () 105 | () 106 | () 107 | () 108 | (*) 109 | () 110 | () 111 | () 112 | () 113 | () 114 | () 115 |
| () 118 | () 119 | () 120 | () 121 | () 122 | (*) 123 | () 124 | () 125 | () 126 | () 127 | (*) 128 |
| () 131 | () 132 | () 133 | () 134 | () 135 | () 136 | (*) 137 | () 138 | (*) 139 | () 140 | () 141 |
| () 144 | () 145 | (*) 146 | () 147 | () 148 | () 149 | () 150 | () 151 | () 152 | () 153 | () 154 |

MBPA SUMMARY

THE FOLLOWING IS A LIST OF MONETARY QUOTAS WITH THE NUMBER OF DOLLARS IN EACH.

| | | | | | | |
|----------------|-----------------|-----------------|-----------------|-----------------|-----------------|------------|
| 1 \$ 990000.00 | 2 \$ 1200000.00 | 3 \$ 1110000.00 | 4 \$ 1140000.00 | 5 \$ 1500000.00 | 6 \$ 1110000.00 | 7 \$ 11100 |
| 9 \$ 960000.00 | 10 \$ 870000.00 | | | | | |

MQ SUMMARY

OUTPUT FORMATS

FIGURE 3-7

| COORDINATE NUMBER | TASK ELIMINATION | TECHNICAL VALUE | TOTAL | DELTA | COST | DELTA | RCPT |
|-------------------|------------------|-----------------|-------|-------|-----------|--------|------|
| | | | | | | | |
| 1 | NONE | 6454.537 | NONE | NONE | 15016950. | 0 | NONE |
| 2 | 24 | 6454.533 | 0.004 | 0.004 | 14984950. | 32000. | 0 |
| 3 | 56 | 6454.528 | 0.006 | 0.006 | 14946600. | 38350. | 0 |
| 4 | 24 | 6454.525 | 0.003 | 0.003 | 14914950. | 31650. | 0 |
| 5 | 120 | 6454.515 | 0.010 | 0.010 | 14880750. | 34200. | 0 |
| 6 | 50 | 6454.507 | 0.008 | 0.008 | 14837650. | 43100. | 0 |
| 7 | 50 | 6454.500 | 0.008 | 0.008 | 14807650. | 30000. | 0 |
| 8 | 120 | 6454.488 | 0.011 | 0.011 | 14767000. | 40650. | 0 |
| 9 | 50 | 6454.470 | 0.019 | 0.019 | 14728350. | 38650. | 0 |
| 10 | 30 | 6454.454 | 0.016 | 0.016 | 14695100. | 32250. | 0 |
| 11 | 140 | 6454.435 | 0.019 | 0.019 | 14662200. | 33900. | 0 |
| 12 | 64 | 6454.417 | 0.018 | 0.018 | 14629850. | 32350. | 0 |
| 13 | 60 | 6454.401 | 0.016 | 0.016 | 14597200. | 32650. | 0 |
| 14 | 7 | 6454.370 | 0.023 | 0.023 | 14557900. | 39300. | 0 |
| 15 | 56 | 6454.357 | 0.022 | 0.022 | 14521350. | 36550. | 0 |
| 16 | 121 | 6454.325 | 0.031 | 0.031 | 14483150. | 38200. | 0 |
| 17 | 92 | 6454.286 | 0.039 | 0.039 | 14445850. | 37300. | 0 |
| 18 | 33 | 6454.252 | 0.034 | 0.034 | 14409550. | 36300. | 0 |
| 19 | 27 | 6454.213 | 0.040 | 0.040 | 14378700. | 30850. | 0 |
| 20 | 139 | 6454.170 | 0.035 | 0.035 | 14347700. | 31000. | 0 |
| 21 | 51 | 6454.151 | 0.027 | 0.027 | 14314950. | 32750. | 0 |
| 22 | 74 | 6454.109 | 0.042 | 0.042 | 14284150. | 30800. | 0 |
| 23 | 2 | 6454.071 | 0.038 | 0.038 | 14248700. | 35450. | 0 |
| 24 | 2 | 6454.025 | 0.045 | 0.045 | 14214400. | 34300. | 0 |
| 25 | 130 | 6453.981 | 0.044 | 0.044 | 14182200. | 32200. | 0 |
| 26 | 60 | 6453.916 | 0.065 | 0.065 | 14146600. | 35600. | 0 |
| 27 | 34 | 6453.857 | 0.059 | 0.059 | 14107150. | 39450. | 0 |
| 28 | 162 | 6453.799 | 0.058 | 0.058 | 14076150. | 31000. | 0 |
| 29 | 2 | 6453.697 | 0.102 | 0.102 | 14029300. | 46850. | 0 |
| 30 | 44 | 6453.621 | 0.076 | 0.076 | 13986000. | 43300. | 0 |
| 31 | 60 | 6453.552 | 0.069 | 0.069 | 13944350. | 41650. | 0 |
| 32 | 117 | 6453.492 | 0.061 | 0.061 | 13905200. | 39150. | 0 |
| 33 | 1 | 6453.435 | 0.057 | 0.057 | 13874550. | 30650. | 0 |
| 34 | 3 | 6453.345 | 0.089 | 0.089 | 13842750. | 31800. | 0 |
| 35 | 23 | 6453.292 | 0.054 | 0.054 | 13804050. | 38700. | 0 |
| 36 | 44 | 6453.196 | 0.095 | 0.095 | 13768550. | 35500. | 0 |
| 37 | 51 | 6453.109 | 0.087 | 0.087 | 13735950. | 32600. | 0 |
| 38 | 143 | 6452.992 | 0.117 | 0.117 | 13697550. | 38400. | 0 |
| 39 | 88 | 6452.868 | 0.124 | 0.124 | 13663350. | 34200. | 0 |
| 40 | 85 | 6452.640 | 0.228 | 0.228 | 13624650. | 38700. | 0 |

TASK ELIMINATION CHART

3.1.2.3.3 Coordinate Configuration

When the "PRINT" card is an input, the data illustrated in Figure 3-9 will result. This lists, according to Monetary Quota, those TASKS which make up the R&D program at the coordinate(s) specified on the "PRINT" card.

In operation, the program examines Table IOUW each time a Task is removed. When it finds that a summary has been requested for a coordinate, the program writes the information on FILE 08. Upon completing the examination of all Tasks, the Configuration summaries are transferred from FILE 08 to FILE 06 so that all information produced by the LRTP program can be printed from one magnetic tape.

3.1.2.4 Using the LRTP Program

Listed below are the steps to be taken in using the program. The list shows all steps. Steps that cannot be by-passed are flagged by an asterisk.

- (a) SORT MBPA/WE Cards
- * (b) Load program decks, control cards and data cards on Tape
- * (c) Place MBPA/WE tape on FILE 09
- * (d) Place tape from (b) on FILE 05
- * (e) Place blank tape on FILE 06
- (f) Place blank tape on FILE 08
- (g) Compile "FILE ASSIGNMENT" subroutine deck
- (h) Compile "LRTP" program deck
- (i) Compile "BCDINT" subroutine deck
- (j) Compile "SKFIL" subroutine deck

CONFIGURATION OF COORDINATE 1
 MC 1 MC 2 MC 3 MC 4 MC 5 MC 6 MC 7 MC 8
 \$ 0. \$ 0. \$ 0. \$ 0. \$ 0. \$ 0. \$ 5000. \$ 0.

| MBPA TASK | MBPA TASK | MBPA TASK | MBPA TASK | MBPA TASK | MBPA TASK | MBPA TASK | MBPA TASK | MBPA TASK |
|-----------|-----------|-----------|-----------|-----------|-----------|-----------|-----------|-----------|
| 1 | 2 | 3 | 4 | 5 | 6 | 7 | 8 | |
| \$ 35400. | \$ 31000. | \$ 32400. | \$ 31800. | \$ 41500. | \$ 32800. | \$ 30650. | \$ 45550. | |
| \$ 35450. | \$ 30100. | \$ 46150. | \$ 41250. | \$ 45900. | \$ 30450. | \$ 39900. | \$ 44000. | |
| | | | \$ 35300. | \$ 36400. | \$ 35300. | \$ 35900. | \$ 45100. | |
| | | | \$ 35400. | \$ 40700. | \$ 36750. | \$ 37050. | | |
| | | | | \$ 38100. | \$ 32900. | | | |
| | | | | \$ 42450. | | | | |

 TOTAL \$ 70850.
 TOTAL \$ 124400.
 TOTAL \$ 78550.
 TOTAL \$ 151750.
 TOTAL \$ 245050.
 TOTAL \$ 168200.
 TOTAL \$ 143750.
 TOTAL \$ 135250.

END OF COORDINATE 1

SUMMARY OF CONFIGURATIONS

OUTPUT FORMAT

FIGURE 3-9

- *(k) Load "FILE ASSIGNMENT" deck
- *(l) Load "LRTP" deck
- *(m) Load "BCDINT" deck
- *(n) Load "SKFIL" deck
- *(o) At this point, whatever course has been

followed above, the LRTP program operates on data from FILES 05 and 09, recording information on FILES 06 and 08 (if requested), according to control information on FILES 05 and 09. Upon completion of program operation:

- *(p) Print FILE 06

3.2 Definition of TABLES and ITEMS

Listed below are terms used in the LRTP program. The definitions attached to these terms reflect, where appropriate, the symbols used in Section 2, Mathematical Description of LRTP Model.

| | |
|------|---|
| VALU | = table of technical values of MBPA's, $V_k(r_k)$ |
| COST | = table of first year costs of TASKS, C_{jk} |
| NUTE | = table of identification numbers of TASKS, (j) |
| CSPS | = table of expected costs of TASKS, $E_{jk}(r_{jk})$ |
| PSTE | = table of probabilities of success of TASKS, $P_{jk}(r_{jk})$, or table of probabilities of failure of TASKS $N_{jk}(r_{jk})$ |
| TECH | = table of ratios V_{jk}/E_{jk} |
| DVAL | = table of values of V_{jk} |
| MQNO | = table of the Monetary Quota number of the first WE of the TASK |
| TCST | = annual cost $C(r)$ of a Configuration |
| TVAL | = technical value $V(r)$ of a Configuration |
| MBNO | = table of identification numbers of MBPA's $k=1, 2, \dots, a \leq 9999$ |

FREQ = table of values of $w_k e_k U_k$
MBCD = table of values of h_k where;
 $h_k = *$: denotes the MBPA cannot be dropped;
 $h_k = \text{blank}$: denotes the MBPA can be dropped
NOTE = table of count of TASKS in each MBPA, d_k
QUOT = table of minimum funds that must be allocated
to each Monetary Quota $F = (f_1, f_2, \dots, f_n,$
 $\dots, f_b)$ where $b < 1000$ and number of MQ's ≤ 100
MQID = table of identification numbers of Monetary
Quotas $N = (n_x, n_y, \dots, n_z)$ where $x, y, z \leq 999$
and number of $N(s) \leq 100$; and no n equals another
BUDG = table of Monetary Quota Cost of a Configuration,
 $Q(r) = (q_1, q_2, \dots, q_b)$
LXTE - Table of factors for setting indexes in tables that
contain information about Tasks
NODR - Table where a count is maintained of the Tasks
eliminated from a MBPA
LPHA - Table of the representations of letters, digits
and special characters
INPT - Table into which card images are read
IOUT - Table in which coordinate numbers are stored.

3.3 Flow of LRTP Program

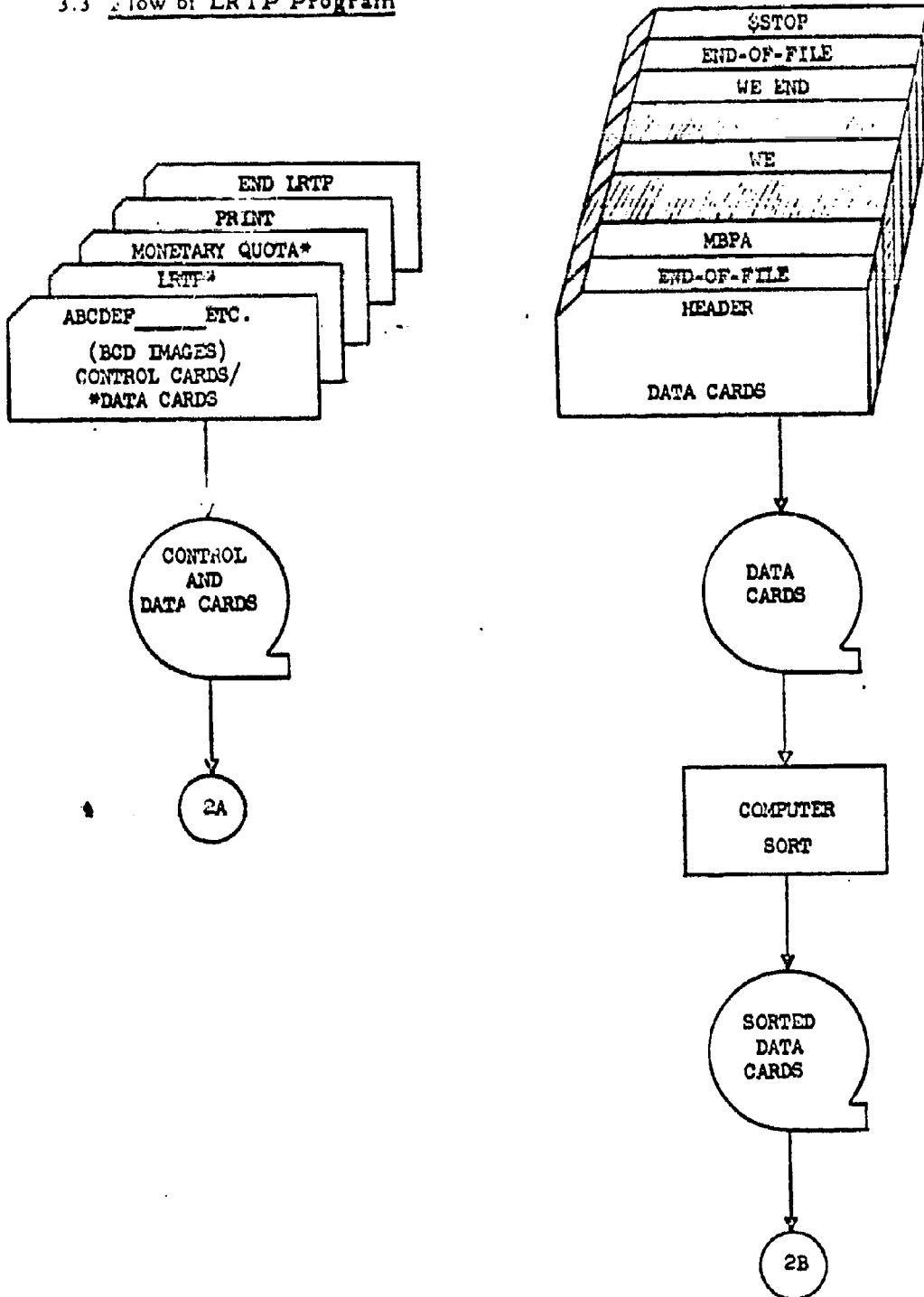

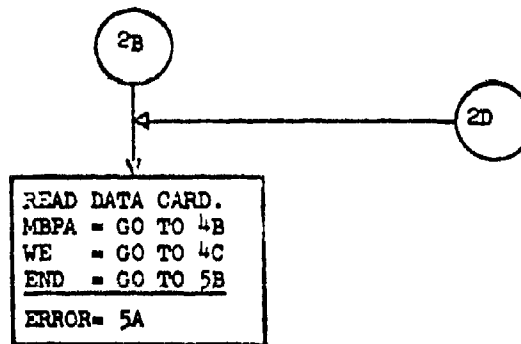
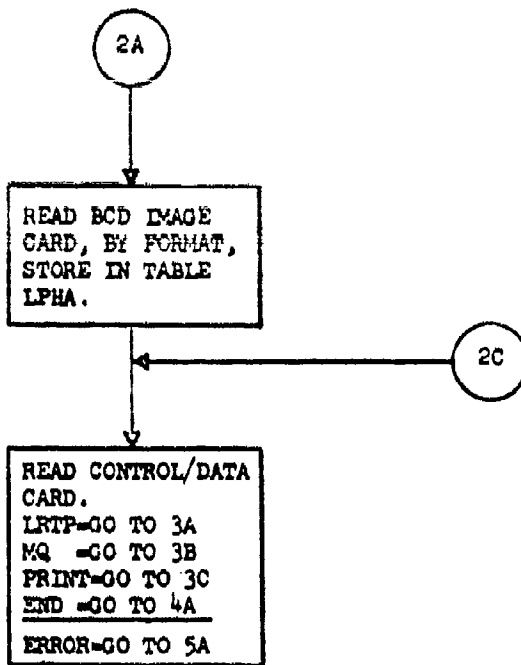

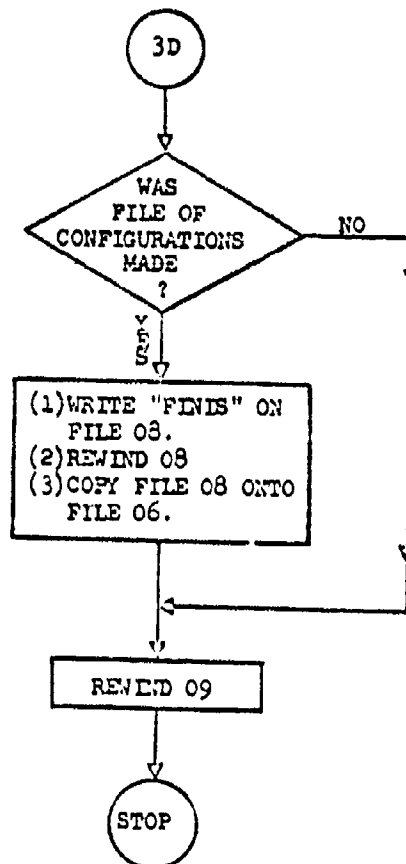
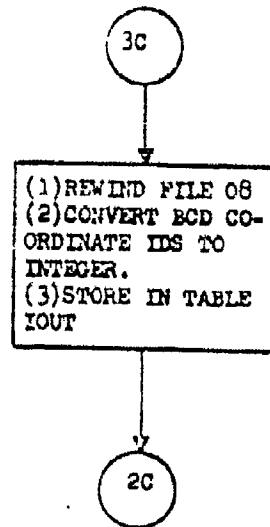
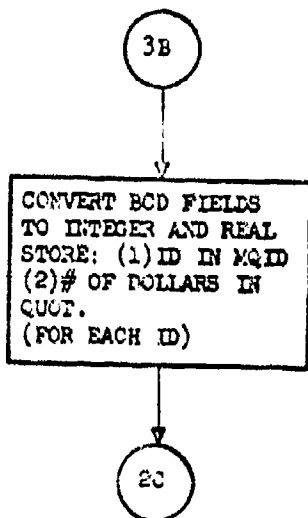
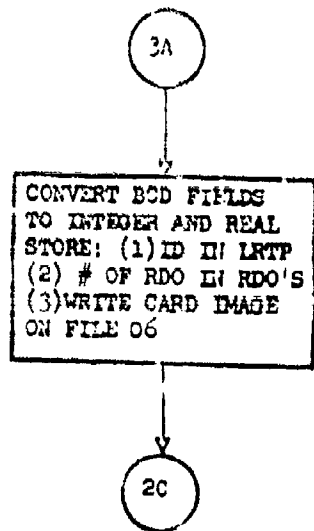

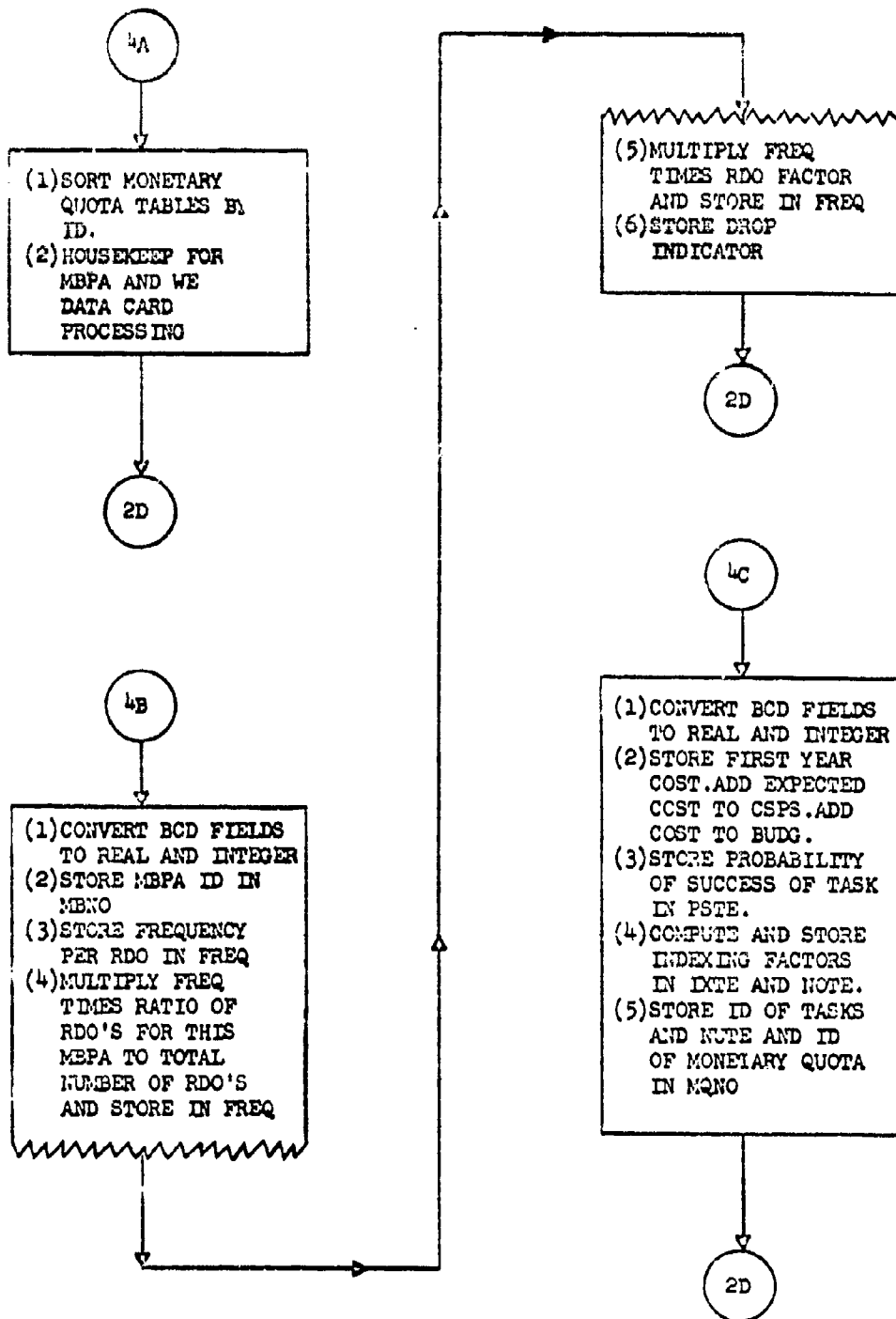

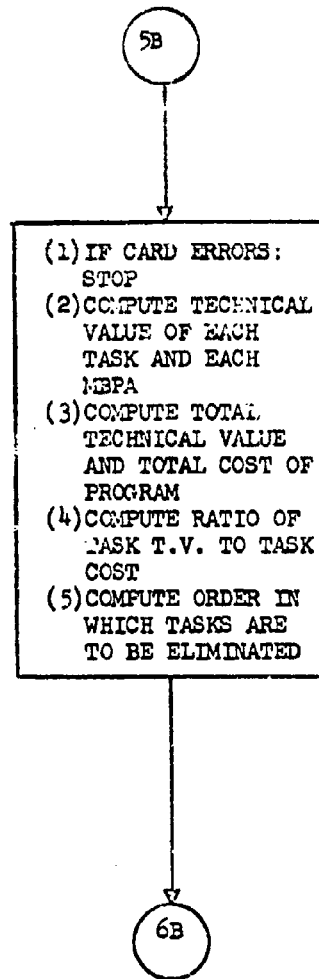
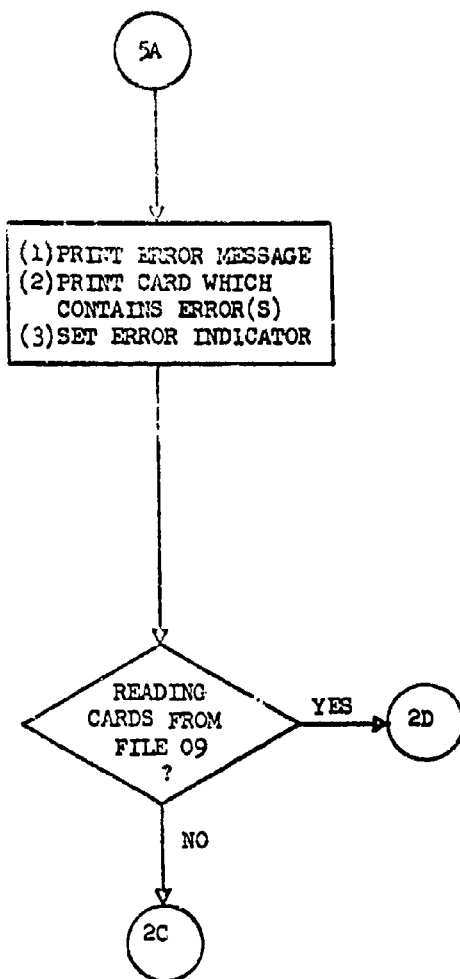

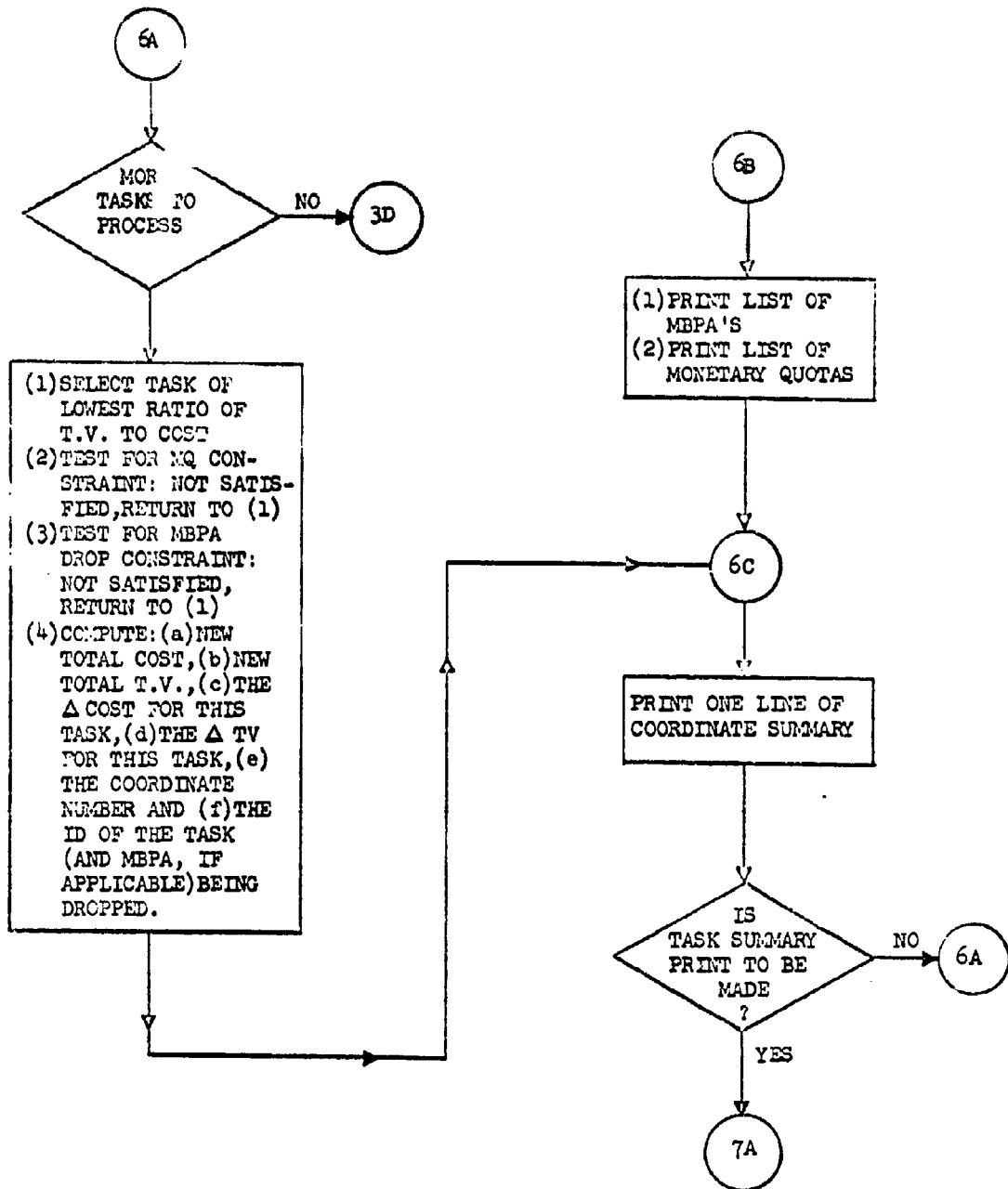

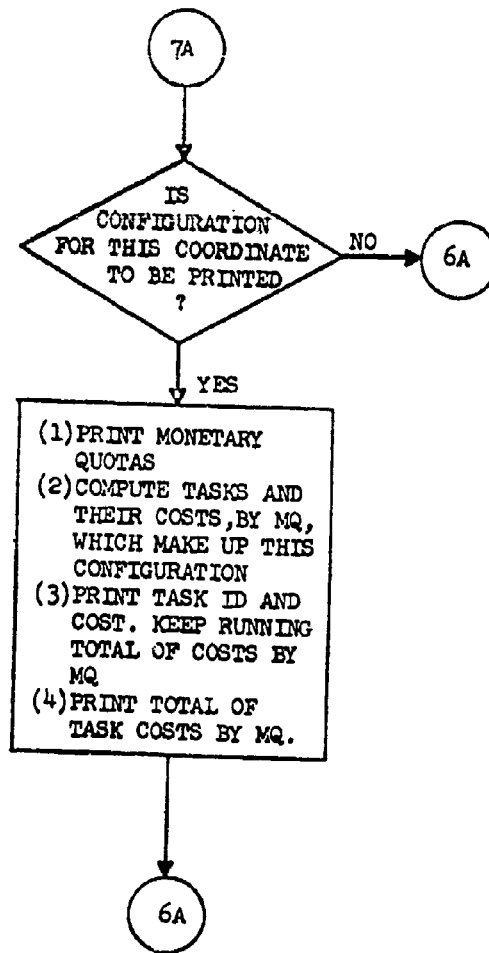

3.4 Fortran Listing

EXTERNAL FORMULA NUMBER - SOURCE STATEMENT

```
COMMON LPHA(4), INPT(072), INCH, NOCH, INTG, IERR, INTI
COMMON IXTE(500), IPTI, IPCH, NPCH, IPTG, IPRR
DIMENSION BUDG(100), MQID(100), QUOT(100), FREQ(500), MBNO(500),
2MBCD(500), NODK(500), NOTE(500), VALU(500), COST(1500), CSPS(1500),
3NUTE(1500), PSTE(1500), TECH(1500), DVAL(1500), IOUT(16),
4MQNO(1500), CBUF(10), CMQT(10), KBUF(10), MBUF(10)
REWIND 9
I = 0
INER = 0
MSTK = 0
LRCD = 0
DO 104 J = 1, 100
MQID(J) = 0
QUOT(J) = 0.
BUDG(J) = 0.
104 CONTINUE
READ (5, 190) (LPHA(N), N=1, 43)
100 READ (5, 191) (INPT(N), N=1, 72)
IF (INPT(1).EQ.LPHA(13)) GO TO 140
IF (INPT(1).EQ.LPHA(12)) GO TO 130
IF (INPT(1).EQ.LPHA(16)) GO TO 500
IF (INPT(1).EQ.LPHA(5)) GO TO 200
GO TO 180
102 READ (9, 191) (INPT(N), N=1, 72)
CALL SKFIL
101 READ (9, 191) (INPT(N), N=1, 72)
IF (INPT(1).EQ.LPHA(23)) GO TO 110
IF (INPT(1).EQ.LPHA(13)) GO TO 120
GO TO 180
110 IF (INPT(4).EQ.LPHA(5)) GO TO 300
INCH = 6
NOCH = 4
CALL BCDINT
IF (IERR.EQ.1) GO TO 180
IDMB = INTG
INCH = 11
NOCH=3
CALL BCDINT
IF (IERR.EQ.1) GO TO 180
IDTE = INTG
INCH = 15
NOCH = 3
CALL BCDINT
IF (IERR.EQ. 1) GO TO 180
IDWE = INTG
INCH = 19
NOCH = 3
CALL BCDINT
IF (IERR.EQ.1) GO TO 180
IDMC = INTG
INCH = 23
NOCH = 3
CALL BCDINT
IF (IERR.EQ.1) GO TO 180
PSTK = INTG
```

EXTERNAL FORMULA NUMBER - SOURCE STATEMENT

```

PSTK = PSTK/100.
INCH = 27
NOCH = 8
CALL BCDINT
IF (IERR.EQ.1) GO TO 180
CSWE = INTG
IF (IDWE .GT. 1) GO TO 103
CSTK = CSWE
DO 30 JK = 1, IENT
IF (LMID(JK).NE.IDMQ) GO TO 30
BUDG(JK) = BUDG(JK) + CSTK
GO TO 109
30 CONTINUE
GO TO 180
103 CSTK = 0.
109 IF (LMID.EQ.IDMB.AND.LTID.EQ.IDTE) GO TO 111
IF (LMID.EQ.IDMB.AND.LTID.NE.IDTE) GO TO 112
K = K + 1
DO 31 M = 1, JENT
IF (MBND(M).NE.IDMB) GO TO 31
NOTE(M) = 1
IXTE(M) = K
GO TO 106
31 CONTINUE
GO TO 180
106 LMID = IDMB
113 LTID = IDTE
NUTE(K) = IDTE
PSTE(K) = PSTK
COST(K) = CSTK
CSPS(K) = CSWE
MOND(K) = IDMQ
GO TO 101
112 K = K + 1
NOTE(M) = NOTE(M) + 1
GO TO 113
111 PSTE(K) = PSTE(K)*PSTK
CSPS(K) = CSWE*PSTK + CSPS(K)
GO TO 101
120 INCH = 6
NOCH = 4
CALL BCDINT
IF (IERR.EQ.1) GO TO 180
J = J + 1
JENT = J
MBND(J) = INTG
INCH = 11
NOCH = 3
CALL BCDINT
IF (IERR.EQ.1) GO TO 180
FREQ(J) = INTG
FREQ(J) = FREQ(J)/100.
INCH = 15
NOCH = 3
CALL BCDINT
IF (IERR.EQ.1) GO TO 130

```

EXTERNAL FORMULA NUMBER - SOURCE STATEMENT

```
PARD = INTG
FREQ(J) = (PARD/RDOS)*FREQ(J)
INCH = 19
NOCH = 4
CALL BCDINT
IF (IERR.EQ.1) GO TO 180
TEMP = INTG
FREQ(J) = FREQ(J)*TEMP
IF (INPT(24).EQ.LPHA(48)) GO TO 121
MBCD(J) = LPHA(44)
GO TO 101
121 MBCD(J) = LPHA(48)
GO TO 101
130 INCH = 6
NOCH = 2
CALL BCDINT
IF (IERR.EQ.1) GO TO 180
LRTP = INTG
INCH = 17
NOCH = 3
CALL BCDINT
IF (IERR.EQ.1) GO TO 180
RDOS = INTG
WRITE (6,194)
WRITE (6,195)
WRITE (6,193) (INPT(N),N=1,72)
WRITE (6,195)
LINE = 58
GO TO 100
140 I = I + 1
INCH = 4
NOCH = 3
CALL BCDINT
IF (IERR.EQ.1) GO TO 180
MQID(I) = INTG
INC. = 8
NOCH = 8
CALL BCDINT
IF (IERR.EQ.1) GO TO 180
QUOT(I) = INTG
IENT = I
GO TO 100
180 IF (INER.EQ.1) GO TO 181
INER = 1
WRITE (6,192)
LINE = LINE - 2
181 WRITE (6,193) (INPT(I),I=1,72)
LINE = LINE - 2
IF (LINE.GT.6) GO TO 183
WRITE (6,194)
WRITE (6,195)
WRITE (6,195)
LINE = 60
183 IF (MRTK.EQ.1) GO TO 101
GO TO 100
200 IJNT = IENT - 1
```

EXTERNAL FORMULA NUMBER - SOURCE STATEMENT

```

DO 40 IJ = 1, IJNT
JI = IJ + 1
IF (MQID(IJ).LE.MQID(JI)) GO TO 40
KEMP = MQID(JI)
TEMP = QUOT(JI)
MQID(JI) = MQID(IJ)
QUOT(JI) = QUOT(IJ)
MQID(IJ) = KEMP
QUOT(IJ) = TEMP
IF (IJ.EQ.1) GO TO 40
IK = IJ
41 IK = IK - 1
KI = IK + 1
IF (IK .EQ. 0) GO TO 40
IF (MQID(IK) .LE. MQID(KI)) GO TO 40
KEMP = MQID(IK)
TEMP = QUOT(IK)
MQID(IK) = MQID(KI)
QUOT(IK) = QUOT(KI)
MQID(KI) = KEMP
QUOT(KI) = TEMP
GO TO 41
40 CONTINUE
DO 202 J = 1,500
NOTE(J) = 0
NODR(J) = 0
VALU(J) = 0.
MBNO(J) = 0
202 CONTINUE
DO 201 K = 1, 1500
NUTE(K) = 0
MQND(K) = 0
TECH(K) = 0.
COST(K) = 0.
CSPS(K) = 0.
PSTE(K) = 1.
DVAL(K) = 0.
201 CONTINUE
I = 0
J = 0
K = 0
L = 0
LMID = 0
LTID = 0
MBTK = 1
GO TO 102
280 IF (LRCD .NE. 1) GO TO 281
WRITE (8,1903)
REWIND 8
GO TO 505
506 WRITE (6,1902) (IXTE(N), N=1,120)
505 READ (8,1902) (IXTE(N), N=1,120)
IF (IXTE(2) .NE. LPHA(6)) GO TO 506
REWIND 8
281 REWIND 9
STOP

```

EXTERNAL FORMULA NUMBER - SOURCE STATEMENT

```

300 IF (INER.EQ.1) GO TO 280
    KENT = K
    NUMB = 0
    TCST = 0.
    TVAL = 0.
    DO 2 J = 1, JENT
        NUMB = NOTE(J) + NUMB
        KIND = IXTE(J)
        PFTE = 1.
        DO 1 K = KIND, NUMB
            TCST = COST(K) + TCST
            PSTE(K) = 1. - PSTE(K)
            PFTE = PFTE*PSTE(K)
1 CONTINUE
        PFTE = 1. - PFTE
        VALU(J) = FREQ(J)*PFTE
        TVAL = VALU(J) + TVAL
2 CONTINUE
    TEMP = 0.
    DO 6 NOTK = 1, KENT
        NUMB = 0
        DO 3 I = 1, JENT
            NUMB = NOTE(I) + NUMB
            KIND = IXTE(I)
        DO 4 J = KIND, NUMB
            IF (PSTE(J) .EQ.1.) GO TO 4
            PSUB = PSTE(J)
            PSTE(J) = 1.
            PFTE = 1.
            DO 5 K = KIND, NUMB
                PFTE = PFTE * PSTE(K)
5 CONTINUE
            TVUB = (1. - PFTE) * FREQ(I)
            DVAL(J) = VALU(I) - TVUB
            TECH(J) = DVAL(J) / CSPTS(J)
            PSTE(J) = PSUB
4 CONTINUE
3 CONTINUE
        VEMP = 1.
        DO 7 L = 1, KENT
            IF (TECH(L) .GE. VEMP) GO TO 7
            VEMP = TECH(L)
            LIND = L
7 CONTINUE
        L = LIND
        TEMP = TEMP + 1.
        TECH(L) = TEMP
        PSTE(L) = 1.
        DO 8 M = 1, JENT
            IF (L .GE. IXTE(M) + NOTE(M)) GO TO 8
            IF (L .LT. IXTE(M)) GO TO 8
            VALU(M) = VALU(M) - DVAL(L)
            GO TO 6
8 CONTINUE
6 CONTINUE
    VEMP = 0.

```

EXTERNAL FORMULA NUMBER - SOURCE STATEMENT

```

GO TO 400
310 VEMP = VEMP + 1.
DO 350 K = 1, KENT
IF (TECHK) .NE. VEMP) GO TO 350
GO TO 355
350 CONTINUE
GO TO 280
355 IDMQ = 0
DO 352 I = 1, IENT
IF (MQID(I).NE.MQNO(K)) GO TO 352
IDMQ = 1
IF (BUDG(I)-COST(K).LT.QUOT(I)) GO TO 310
GO TO 351
352 CONTINUE
IF (IDMQ .EQ. 0) GO TO 310
351 DO 353 M = 1, JENT
IF (K .GE. IXTE(M) + NOTE(M)) GO TO 353
IF (K .LT. IXTE(M)) GO TO 353
IF (NOTE(M) -NODR(M).GT.1) GO TO 354
IF (MBCD(M).EQ.LPHA(44)) GO TO 310
IF (NOTE(M)-NODR(M).EQ.1) GO TO 354
GO TO 310
353 CONTINUE
GO TO 310
354 IDMB = MBNO(M)
IDTE = NUTE(K)
TCST = TCST - COST(K)
DELC = COST(K)
NODR(M) = NODR(M) + 1
IF (NOTE(M) - NODR(M) .NE. 0) GO TO 356
MBTK = MBNO(M)
356 KORD = KORD + 1
MQNO(K) = MQNO(K) - 1000
BUDG(I) = BUDG(I) - COST(K)
COST(K) = J.
DELV = DVAL(K)
TVAL = TVAL - DELV
GO TO 450
400 KLIN = JENT/13 + 4
IF (LINE - KLIN.GE.5) GO TO 409
WRITE (6,194)
WRITE (6,195)
WRITE (6,195)
LINE = 62
409 WRITE (6,196)
LINE = LINE - 2
WRITE (6,197) (MBCD(J),MBNO(J),J=1,JENT)
LINE = LINE - (JENT/13)
KLIN = IENT/4 + 3
IF (LINE - KLIN.GE.3) GO TO 403
WRITE (6,194)
WRITE (6,195)
WRITE (6,195)
403 WRITE (6,198)
WRITE (6,199) (MQID(I),QUOT(I),I=1,IENT)
LINE = 6

```

EXTERNAL FORMULA NUMBER - SOURCE STATEMENT

```

KORD = 1
MBTK = 0
450 IF (LINE.GT.6) GO TO 451
    WRITE (6,194)
    WRITE (6,195)
    WRITE (6,1190)
    WRITE (6,1191)
    WRITE (6,1192)
    LINE = 51
    IF (KORD.GT.1) GO TO 451
    WRITE (6,1193) TVAL, TCST
    GO TO 470
451 WRITE (6,1194) KORD, IDMB, IDTE, TVAL, DELV, TCST, DELC, MBTK
    MBTK = 0
470 IF (LRCD.NE.1) GO TO 310
    IF (KORD.GT.1) GO TO 471
    WRITE (8,1900) LRTP
    WRITE (8,195)
471 DO 477 L = 1, LENT
    IF (KORD.EQ. IOUT(L)) GO TO 478
477 CONTINUE
    GO TO 310
478 WRITE (8,1901) KORD
    DO 60 L = 1, KENT
    PSTE(L) = 0.
    60 CONTINUE
    II = ((IENT-1)/10) + 1
    M = -9
    N = 0
    DO 90 I = 1, II
    M = M + 10
    N = N + 10
    IF (N.LE.IENT) GO TO 91
    N = IENT
91 WRITE (8,1195) (MQID(MM),MM = M,N)
    WRITE (8,1196) (QUOT(MM),MM = M,N)
    WRITE (8,1197)
    WRITE (8,1198)
    WRITE (8,1197)
    DO 472 LL = 1, 10
    KBUF(LL) = 0
    MBUF(LL) = 0
    CBUF(LL) = 0.
    CMQT(LL) = 0.
472 CONTINUE
92 MQGO = 0
    DO 80 L = 1, KENT
    IF (MQNO(L).LT.MQID(M)) GO TO 80
    IF (MQNO(L).GT.MQID(N)) GO TO 80
    IF (PSTE(L).EQ. -1.) GO TO 80
    MQGO = 1
    DO 70 K = M, N
    IF (MQID(K).NE.MQND(L)) GO TO 70
    J = K
88 IF (J.LT.11) GO TO 87
    J = J - 10

```

EXTERNAL FORMULA NUMBER SOURCE STATEMENT

```
GO TO 80
87 IF (CBUF(J).NE.0.) GO TO 80
   CBUF(J) = COST(L)
   CMQT(J) = CMQT(J) + COST(L)
   KBUF(J) = NUTE(L)
   DO 50 JJ = 1,JENT
   IF (L.GE. IXTE(JJ) + NOTE(JJ)) GO TO 50
   IF (L.LT. IXTE(JJ)) GO TO 50
   MBUF(J) = MBNO(JJ)
   PSTE(L) = -1.
   GO TO 80
50 CONTINUE
70 CONTINUE
80 CONTINUE
   DO 474 LL = 1,10
   IF (MBUF(LL).NE.0) GO TO 475
474 CONTINUE
   GO TO 476
475 WRITE (8,1199) (MBUF(LL),KBUF(LL),LL = 1,10)
   WRITE (8,1196) (CBUF(LL),LL = 1,10)
   DO 473 LL = 1,10
   KBUF(LL) = 0
   MBUF(LL) = 0
   CBUF(LL) = 0.
473 CONTINUE
   IF (MQGO.NE.0) GO TO 92
476 WRITE (8,1197)
   WRITE (8,1200)
   WRITE (8,1196) (CMQT(LL),LL = 1,10)
   WRITE (8,1197)
   WRITE (8,195)
90 CONTINUE
   WRITE (8,1201) KORD
   WRITE (8,194)
   GO TO 310
500 REWIND 8
   DO 508 J = 1, 16
   IOUT(J) = 0
508 CONTINUE
   LRCD = 1
   LENT = 0
   INCH = 7
   NOCH = 0
   KEMP = 0
   DO 507 J = 1, 16
501 IF (KEMP.GT.1) GO TO 100
   INCH = INCH + NOCH * KEMP
   NOCH = 0
   KEMP = 0
   DO 503 N = INCH,72
   IF (INPT(N).EQ.LPHA(48)) GO TO 502
   IF (KEMP.EQ.1) GO TO 504
   NOCH = NOCH + 1
   GO TO 503
502 KEMP = KEMP + 1
   IF (KEMP.GT.1) GO TO 504
```

EXTERNAL FORMULA NUMBER - SOURCE STATEMENT

```

503 CONTINUE
    IF (NOCH.EQ.C) GO TO 100
504 CALL BCDINT
    IF (IERR.EQ.1) GO TO 180
    IOUT(J) = INTG
    LENT = J
507 CONTINUE
    GO TO 100
190 FORMAT (48A1)
191 FORMAT (72A1)
192 FURMAT (1H), 97H(HE FOLLOWING CARD(S) CONTAIN(S) ERROR(S) THAT MUS
    2T BE CORRECTED BEFORE COMPUTATIONS CAN BE MADE.)
193 FORMAT (1H),72A1)
194 FORMAT (1H1,119X)
195 FORMAT (1H),119X)
196 FORMAT (109H FOLLOWING IS A LIST OF MBPA(S) FOR THIS RUN OF THIS
    2PROGRAM. THOSE PRECEDED BY ASTERISKS CANNOT BE DROPPED.)
197 FORMAT (13(3H (,1A1,1H),14))
198 FORMAT (76H FOLLOWING IS A LIST OF MONETARY QUOTAS WITH THE NUMBE
    2R OF DOLLARS IN EACH.)
199 FORMAT (8(13,2H $,F9.0,1H*))
1190 FORMAT (103H) COORDINATE * TASK ELIMINATED * TECHNICAL VALUE
    2 * COST * MBPA ELIMINATED)
1191 FORMAT (97H NUMBER * MBPA TASK * TOTAL DELTA
    2 * TOTAL DELTA * MBPA)
1192 FORMAT (120X)
1193 FORMAT (37H 1 NONE NONE ,F9.3,15H NONE
    2 $,F11.0,25H $ NONE NONE)
1194 FORMAT (5X,14,10X,14,4X,13,7X,F9.3,2X,F7.3,6X,F11.0,2X,F9.0,9X,14)
1195 FORMAT (1H,9(5H MQ ,13,4X),5H MQ ,13,3X)
1196 FORMAT (1H,9(1H$,F9.0,2X),1H$,F9.0,1X)
1197 FORMAT (10(12H ***** ))
1198 FORMAT (12H) MBPA TASK ,9(12H MBPA TASK ))
1199 FORMAT (10(2X,14,1X,13,2X))
1200 FORMAT (10(3X,5HTOTAL,4X))
1201 FORMAT (19H) END OF COORDINATE,14,97X)
1900 FORMAT (10H) LRTP ,12,108X)
1901 FORMAT (30H)CONFIGURATION OF COORDINATE ,14,86X)
1902 FORMAT (120A1)
1903 FORMAT (6H FINIS,114X)
END

```

EXTERNAL FORMULA NUMBER - SOURCE STATEMENT -

```
SUBROUTINE BCDINT  
COMMON LPHA(48), INPT(072), INCH, NOCH, INTG, IERR, INTI  
COMMON IXTE(500), IPTI, IPCH, NPCH, IPTG, IPRR  
INTI = 0  
INTG = 0  
IERR = 0  
IF (NOCH.EC.0) GO TO 5  
DO 1 J=1, NOCH  
K = J+ INCH - 1  
DO 2 I = 1, 10  
L = I + 26  
IF (INPT(K).EQ.LPHA(L)) GO TO 3  
2 CONTINUE  
IF (INPT(K).EQ.LPHA(48)) GO TO 4  
5 IERR = 1  
6 RETURN  
4 IF (INTG.NE.0) GO TO 5  
GO TO 7  
3 INTG = INTG * 10 + I - 1  
INTI = 1  
1 CONTINUE  
RETURN  
7 IF (INTI.EC.0) GO TO 1  
GO TO 5  
END
```

3.5 Debugging Log

In the course of getting a computer program to operate correctly, one attempts to follow a process which will achieve one's objective most quickly and most economically. Computer operating systems contain routines to aid in this checkout process. The IBSYS system provides the PDUMP routine, and this was the means used to verify the correctness of the program's operations.

The "Debugging" went as follows:

(a) Check out card reading processes -- Use as input the cards described in Sections 3.1.1.2, 3.1.1.3 and 3.1.1.4. Verify their correct reading by PDUMP of Tables BUDG, MQID, QUOT, FREQ, MBNO, MBCD, IXTE, NOTE, NUTE, PSTE, COST, CSPA, MQNO, IOU^T and LPHA.

(b) Check out error routine -- Introduce cards with erroneous data in each field. Examine Item INER (input error indicator) as well as output messages which specified the card(s) in error.

(c) Check out computations -- Using input data that had been checked in the course of (a) above, record, via PDUMP, Tables PSTE, TECH, VALU and DVAL as the computations are being made. Check enough cases to ascertain the correctness of the results.

(d) Check output -- With data from (c) as criteria, verify that same information that is in tables is printed. Examine outputs themselves for correctness of format.

Upon completion of these tests, the program was operated to produce the information described in Section 4., entitled, "Numerical Examples of Model Outputs".

4. NUMERICAL EXAMPLES

The purpose of this section is to illustrate computer program outputs for several sets of input constraints by making use of hypothetical data. The volume of data, estimated by personnel at Headquarters, AMC, is believed to be representative of the amount of data that may be encountered in actual operation. No further significance should be attached to the hypothetical data, or computer outputs, presented herein.

4.1 Generation of Hypothetical Data

4.1.1 Generation of MBPA-TK-WE Structure

The generation of the hypothetical input data was based on the assumption that Headquarters, AMC, received descriptions of 55 Research Development Objectives (RDO's); the number 55 was chosen because there are 55 RDO's in the 1 October 1964 issue of the Research and Development Long Range Plan (RDLRP). It was further assumed that the 55 RDO's resulted in the identification of 150 Major Barrier Problem Areas (MBPA's).

The number of Tasks associated with each MBPA was assumed to be uniformly distributed between 1 and 4 with a mean of 2.5. The distribution was sampled to determine the number of Tasks (TK's) associated with each MBPA. This sampling resulted in a total of 388 TK's.

4.1.2 MBPA Parameters

The number of RDO's that each MBPA is associated with was derived by sampling a Poission distribution with a mean of 10.

Given that an MBPA was associated with an RDO, a uniform distribution between 1 and 5 with mean of 3 was sampled to determine the frequency of appearance of an MBPA within an RDO. Furthermore, it was assumed that the number of Technical Approaches associated with an RDO was equal to the sum of the frequencies of appearance of MBPA's within RDO's. The above generated values (frequencies and number of Technical Approaches) were then utilized to determine the expected probability that each MBPA will be encountered in a Technical Approach.

4.1.3 Annual Work Effort Parameters

The costs of the Annual Work Efforts (WE's) were assumed to be uniformly distributed between \$30,000 and \$50,000 with mean of \$40,000. The cost of each WE was determined by sampling this distribution.

The probability of success of each WE was determined by assigning one of six values (.05, .20, .40, .50, .80, .95). These values were assumed to be binomially distributed with a mean .5.

After determining the cost and probability of success of each WE, the WE's associated with each Task were sequenced in order of increasing value of cost/1-Probability of Success.

Furthermore, it was also assumed that a total of 10 Field Establishments (Monetary Quotas) proposed the Tasks and the assignments of Tasks were assumed to be randomly distributed among the Field Establishments.

4.2 Computer Runs

Using the hypothetical MBPA and WE parameters previously discussed seven computer runs were made varying the MBPA and Monetary Quota (MQ) cost constraints from run to run. These runs were made utilizing the IBM 7090 computer at the U. S. Army Strategy Tactics and Analysis Group, Bethesda, Maryland. The print out of one of the runs is given in Appendix II.

The outputs of the seven runs are given in Figures 4-1 and 4-2. All of the Configurations produced by each run have not been plotted because of the limited size of each figure, but a sufficient number points are given to clearly portray the shape and characteristics of the curves.

4.2.1 Outputs Varying MBPA Work Effort Constraints

The curves in Figure 4-1 illustrate the effect of varying the MBPA constraints without any MQ constraints (zero funds for each MQ).

Curve A depicts the Configurations of maximum expected technical value in which no MBPA need be funded. Since the 150 MBPA's comprise 388 TK's, the total number of possible Configurations (or points on the curve) is 389. Appendix II contains a complete listing of all these Configurations. Of this number, 389, the first (the Configuration consisting of 388 TK's), the last (the Configuration consisting of 0 TK's), and every tenth one were plotted. For Curve A (as well as the other curves), the cost intervals between points (i. e., the change along the abscissa) is quite uniform. This is a consequence of the fact that the cost of a WE was postulated in the relatively narrow range of \$30,000 - \$50,000. Thus, the cost interval between any pair of plotted points is around \$400,000 (10 x \$40,000). The expected technical value intervals between points (i. e., the change along the ordinate), however, increases as one progresses along the curve from right to left as expected.

Figure 4-1
 CONFIGURATIONS OF MAXIMUM EXPECTED TECHNICAL VALUE UNDER
 VARIOUS MBPA CONSTRAINTS AND IQ CONSTRAINTS

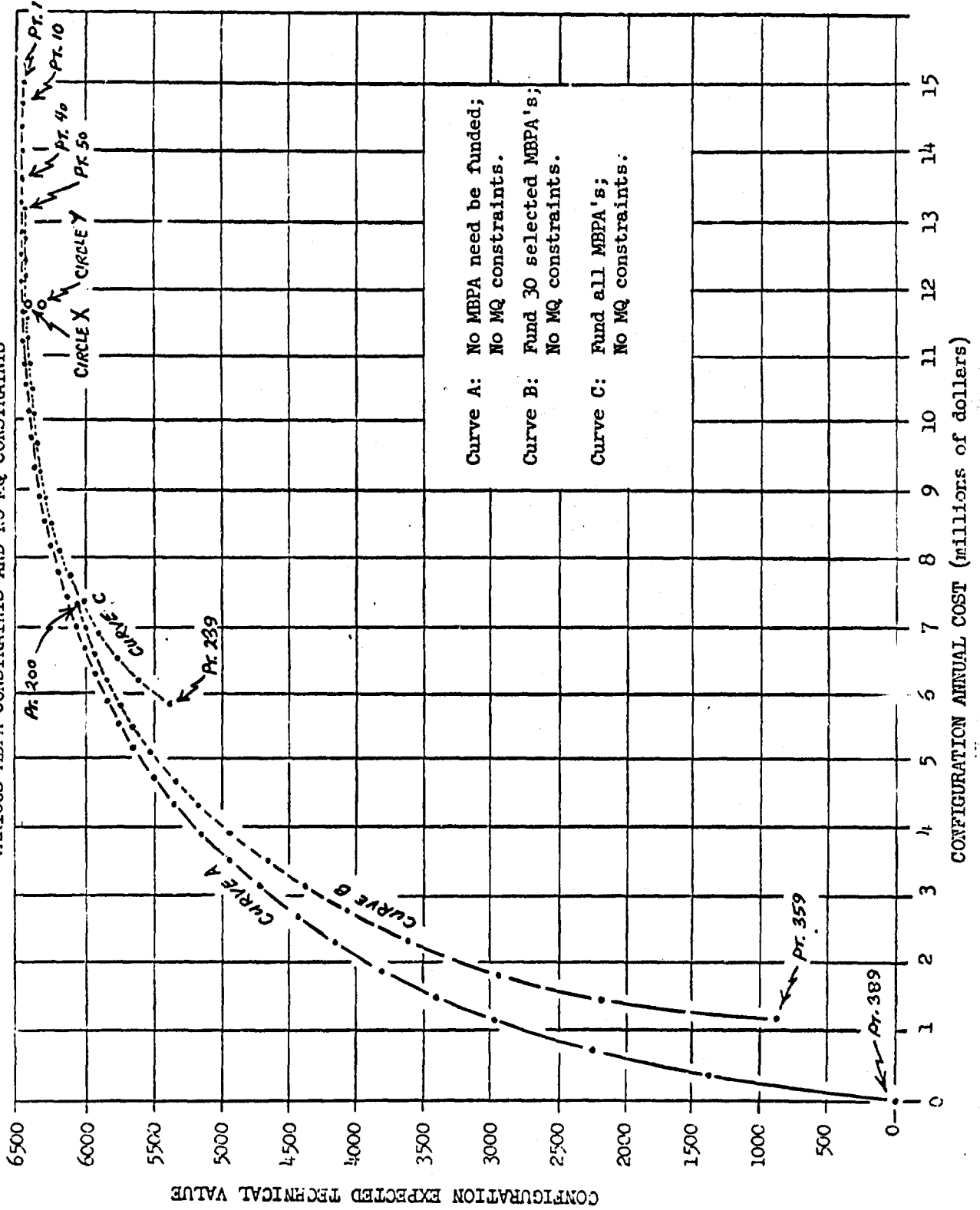

Curve C depicts the Configurations of maximum expected technical value in which all MBPA's must be funded. Since there are 150 MBPA's, the total number of possible Configurations is 239 (388-150+1) and ranges from the Configuration consisting of 388 TK's to one of 150 TK's (i. e., one for each MBPA). The curve stops at point 239 since none of the remaining TK's can be eliminated without violating the requirement that every MBPA must be funded. The last point and every tenth one commencing with No. 50 are plotted. Incidentally, the first 40 points on Curve C are identical with those of Curve A.

Curve B depicts Configurations of maximum expected technical value in which 30 MBPA's (randomly selected) were required to be funded. The total number of such Configurations is 359, of which the last one and every tenth one commencing with No. 200 are plotted. The points to the right of No. 200 are not plotted since they fall between Curves A and B roughly between the plotted points.

4.2.2 Outputs Varying MBPA Work Efforts and MQ Cost Constraints

In Figure 4-2, Curves A_1 , B_1 , C_1 correspond to Curves A, B, C of Figure 4-1 insofar as MBPA constraints are concerned; however, a common set of MQ constraints, as defined below, were applied. Normally, Curves A_1 , B_1 , C_1 , would have been included on Figure 4-1; however, they fall so closely to the curves already plotted on Figure 4-1 that Curves A_1 , B_1 , C_1 would all start with Point No. 1 and end within circle X. Thus they were plotted separately in Figure 4-2 on an enlarged scale. Curve C_2 can be associated with Curve C_1 as discussed below.

Figure 4-2
 CONFIGURATIONS OF MAXIMUM EXPECTED TECHNICAL VALUE
 UNDER VARIOUS MBPA CONSTRAINTS AND MQ CONSTRAINTS

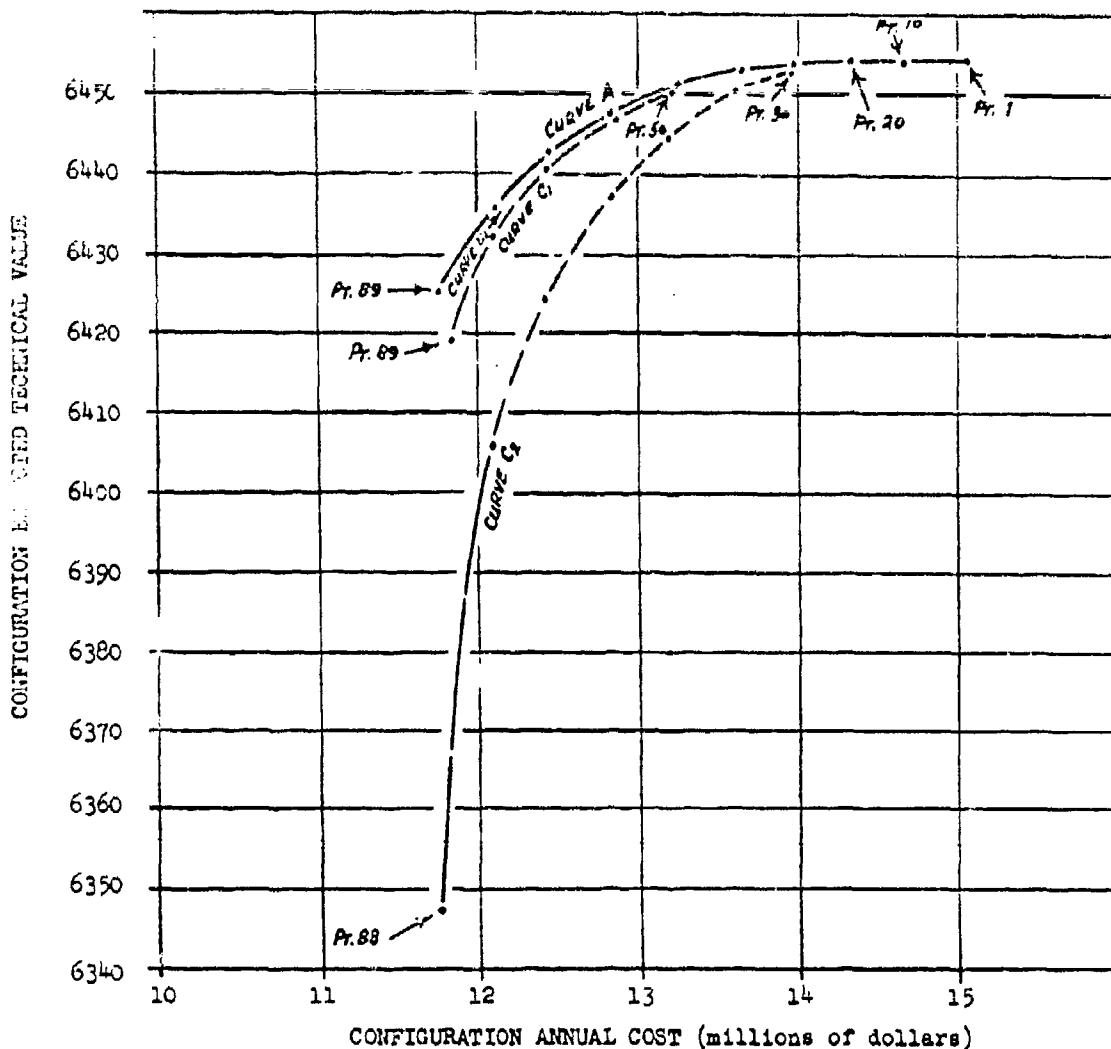

- Curve A₁: No MBPA need be funded; MQ constraints as defined in 4.2.2
- Curve B₁: Fund 30 selected MBPA's; MQ constraints as defined in 4.2.2
- Curve C₁: Fund all MBPA's; MQ constraints as defined in 4.2.2
- Curve C₂: Fund all MBPA's; MQ constraints as defined in 4.2.2

Curve A_1 depicts Configurations of maximum expected technical value in which no MBPA need be funded and with MQ constraints that represent 75% of the number of the 1st fiscal year WE's chargeable to each MQ times the average cost of each WE (\$40,000). The number of possible Configurations is 89. None of the remaining TK's of the last Configuration can be eliminated since a violation of one of the MQ constraints would then occur. The first, last and every tenth Configuration are plotted.

The most significant feature to be noticed upon comparing curves A and A_1 is that Curve A_1 , throughout its length, corresponds very closely to Curve A. In fact, the first 49 Configurations are identical. While not exactly true, it can be stated that the result of imposing the stated MQ constraints upon Curve A is a shortening of Curve A (and thus a reduction in the number of possible Configurations). This ensues because of the relatively narrow and comparatively uniform WE cost figures, i. e., \$50 - \$50,000. For example, commencing with the Configuration consisting of all TK's, each TK is considered for elimination in the same order as that for Curve A. The procedure is to eliminate it if a MBPA constraint or an MQ constraint is not violated. In this case, there are no MBPA constraints so the only consideration is the individual MQ constraints. Since each MQ represents an amount of money that is large in comparison to an individual WE cost and all WE costs are quite uniform, then a considerable number of the TK's to be considered for elimination will be eliminated in their original order. It is re-emphasized that in determining the original order of TK's to be considered for elimination that expected costs were utilized in the calculations; however, once this order is established and MQ constraints are considered only the first fiscal year TK (i. e., WE) cost is involved.

Curve C_1 depicts Configurations of maximum expected technical value in which all MBPA's must be funded and with the same MQ constraints as for Curve A_1 . There are a total of 89 possible Configurations. The last and every tenth one, commencing with No. 50, are plotted. The curve stops at point 89 since elimination of any of the remaining TK's would violate either an MBPA or an MQ constraint. The first 40 Configurations are identical to the first 40 of Curve A_1 ; the number of such occurrences being less in this case than the number (49) in the case of Curves A and A_1 as might be expected because of the inclusion of the MBPA constraints. The discussion in 4.3.3.1 regarding curve length also applies to curve C_1 .

Curve B_1 depicts Configurations of maximum expected military value in which 30 randomly selected MBPA's must be funded and which meet the same MQ constraints as does Curve A_1 . It consists of 89 possible Configurations; the first 40 of which are identical to those of Curve A_1 . The remaining points have not been plotted since they fall between Curves A_1 and C_1 ; merely the position of the curve has been labeled. The discussion in 4.3.3.1 is also applicable herein.

Curve C_2 depicts Configurations of maximum expected technical value in which every MBPA must be funded and which meet MQ constraints defined as follows. The overall amount available in all MQ's was established as \$11,640,000; the same as that for the total of MQ's for curve C_1 . However, the distribution of moneys between MQ's was randomly made and varied from about 50% to 95% of the number of 1st fiscal year WE's chargeable to each MQ times the average cost of each WE (\$40,000) instead of a constant 75% for all MQ's as done for curve C_1 . Expressed in another fashion, the distribution of moneys for the curve C_1 MQ's was such that each AMC R&D Field Establishment was assumed

to have proposed a lot of TK's so that the costs chargeable to the appropriate MQ exceeded the minimum in it by 100% whereas another AMC R&D Field Establishment may have proposed only a few TK's so that the costs chargeable to the appropriate MQ barely exceeded the minimum available in that MQ.

This curve consists of 88 possible Configurations of which every tenth one commencing with No. 30 and the last one are plotted. The last point of this curve falls approximately within the Circle Y indicated in Figure 4-1. No Configuration other than the first is identical to any on curve A_1 . As expected, the shape of this curve departs considerably from those of curves A_1 , B_1 , C_1 ; curve C_2 dropping in expected technical value more rapidly as cost decreases. This results from the fact that the minimum amounts in some MQ's are close to the sums of the costs of all this chargeable to those MQ's; thus few TK's can be dropped which means less desirable TK's may be required to be maintained while more desirable TK's chargeable to other MQ's are eliminated.

APPENDIX I
INPUT CARD DESCRIPTION

APPENDIX II
SAMPLE COMPUTER OUTPUT

COORDINATE * TASK ELIMINATED * EXPECTED * TECHNICAL VALUE * COST * NBPA ELIMINATED
 NUMBER * NBPA TASK * TOTAL DELTA * TOTAL DELTA * NBPA

| COORDINATE NUMBER | TASK ELIMINATED NBPA | TASK | EXPECTED TECHNICAL VALUE TOTAL DELTA | COST TOTAL DELTA | NBPA ELIMINATED NBPA |
|-------------------|----------------------|------|--------------------------------------|------------------|----------------------|
| 1 | NONE | NONE | 6454.537 | 15016950. | NONE |
| 2 | 24 | 2 | 6454.533 | 14984950. | 0 |
| 3 | 56 | 1 | 6454.528 | 14946600. | 0 |
| 4 | 24 | 4 | 6454.525 | 14914950. | 0 |
| 5 | 138 | 4 | 6454.515 | 14880750. | 0 |
| 6 | 50 | 4 | 6454.507 | 14837650. | 0 |
| 7 | 59 | 2 | 6454.500 | 14807650. | 0 |
| 8 | 120 | 3 | 6454.488 | 14767000. | 0 |
| 9 | 50 | 3 | 6454.470 | 14728350. | 0 |
| 10 | 30 | 4 | 6454.454 | 14696100. | 0 |
| 11 | 140 | 2 | 6454.435 | 14662200. | 0 |
| 12 | 64 | 1 | 6454.417 | 14629850. | 0 |
| 13 | 40 | 2 | 6454.401 | 14597200. | 0 |
| 14 | 7 | 4 | 6454.378 | 14557900. | 0 |
| 15 | 54 | 2 | 6454.357 | 14521350. | 0 |
| 16 | 121 | 3 | 6454.325 | 14483150. | 0 |
| 17 | 92 | 1 | 6454.286 | 14445850. | 0 |
| 18 | 33 | 2 | 6454.252 | 14409550. | 0 |
| 19 | 27 | 1 | 6454.213 | 14378700. | 0 |
| 20 | 139 | 3 | 6454.178 | 14347700. | 0 |
| 21 | 51 | 2 | 6454.151 | 14314950. | 0 |
| 22 | 74 | 2 | 6454.109 | 14284150. | 0 |
| 23 | 2 | 2 | 6454.071 | 14248700. | 0 |
| 24 | 138 | 1 | 6454.025 | 14214400. | 0 |
| 25 | 49 | 2 | 6453.981 | 14182200. | 0 |
| 26 | 34 | 3 | 6453.916 | 14146600. | 0 |
| 27 | 142 | 1 | 6453.857 | 14107150. | 0 |
| 28 | 2 | 3 | 6453.799 | 14076150. | 0 |
| 29 | 34 | 1 | 6453.697 | 14029300. | 0 |
| 30 | 44 | 2 | 6453.621 | 13986000. | 0 |
| 31 | 40 | 3 | 6453.552 | 13944250. | 0 |
| 32 | 117 | 2 | 6453.492 | 1390200. | 0 |
| 33 | 1 | 1 | 6453.435 | 13874550. | 0 |
| 34 | 3 | 2 | 6453.345 | 13842750. | 0 |
| 35 | 23 | 1 | 6453.292 | 13804050. | 0 |
| 36 | 44 | 4 | 6453.196 | 13768550. | 0 |
| 37 | 51 | 1 | 6453.109 | 13735950. | 0 |
| 38 | 143 | 4 | 6452.992 | 13697550. | 0 |
| 39 | 88 | 4 | 6452.868 | 13663350. | 0 |
| 40 | 85 | 3 | 6452.640 | 13624650. | 0 |

COORDINATE * TASK ELIMINATED * EXTRACTED * TECHNICAL VALUE * COST * HOPA ELIMINATE
 NUMBER * HOPA TASK * TOTAL DELTA * TOTAL DELTA * HOPA

| COORDINATE NUMBER | TASK ELIMINATED HOPA | TASK | EXTRACTED TECHNICAL VALUE TOTAL | COST TOTAL | HOPA ELIMINATE HOPA |
|-------------------|----------------------|------|---------------------------------|------------|---------------------|
| 41 | 57 | 1 | 6452.496 | 0.145 | 13501550. |
| 42 | 71 | 3 | 6452.340 | 0.155 | 34750. |
| 43 | 108 | 2 | 6452.208 | 0.132 | 25250. |
| 44 | 69 | 4 | 6451.977 | 0.231 | 41550. |
| 45 | 56 | 2 | 6451.790 | 0.187 | 32600. |
| 46 | 25 | 3 | 6451.595 | 0.195 | 49850. |
| 47 | 11 | 1 | 6451.475 | 0.120 | 31700. |
| 48 | 46 | 3 | 6451.275 | 0.200 | 32900. |
| 49 | 135 | 1 | 6451.121 | 0.154 | 34700. |
| 50 | 124 | 3 | 6450.901 | 0.219 | 13249650. |
| 51 | 142 | 3 | 6450.662 | 0.239 | 35750. |
| 52 | 28 | 1 | 6450.500 | 0.162 | 41900. |
| 53 | 10 | 2 | 6450.199 | 0.301 | 46150. |
| 54 | 120 | 2 | 6449.989 | 0.210 | 48800. |
| 55 | 134 | 3 | 6449.793 | 0.196 | 45550. |
| 56 | 130 | 2 | 6449.341 | 0.452 | 48850. |
| 57 | 80 | 2 | 6449.123 | 0.218 | 45400. |
| 58 | 71 | 1 | 6448.828 | 0.296 | 32550. |
| 59 | 58 | 1 | 6448.469 | 0.359 | 35000. |
| 60 | 102 | 2 | 6447.885 | 0.584 | 37200. |
| 61 | 68 | 1 | 6447.568 | 0.316 | 36800. |
| 62 | 43 | 1 | 6446.997 | 0.571 | 39450. |
| 63 | 118 | 2 | 6446.601 | 0.397 | 36250. |
| 64 | 54 | 1 | 6446.028 | 0.573 | 35800. |
| 65 | 3 | 4 | 6445.680 | 0.348 | 40900. |
| 66 | 42 | 4 | 6445.386 | 0.293 | 38850. |
| 67 | 66 | 2 | 6444.636 | 0.751 | 30150. |
| 68 | 64 | 2 | 6444.063 | 0.573 | 46000. |
| 69 | 111 | 3 | 6443.703 | 0.360 | 35800. |
| 70 | 39 | 2 | 6443.263 | 0.460 | 30450. |
| 71 | 16 | 4 | 6442.573 | 0.689 | 30150. |
| 72 | 128 | 1 | 6442.181 | 0.393 | 46000. |
| 73 | 147 | 3 | 6441.708 | 0.472 | 35800. |
| 74 | 25 | 2 | 6441.079 | 0.629 | 40900. |
| 75 | 79 | 2 | 6440.358 | 0.720 | 38850. |
| 76 | 96 | 3 | 6439.831 | 0.527 | 30450. |
| 77 | 143 | 2 | 6439.132 | 0.699 | 46000. |
| 78 | 69 | 2 | 6438.519 | 0.613 | 31550. |
| 79 | 3 | 3 | 6437.765 | 0.754 | 46800. |
| 80 | 78 | 1 | 6437.186 | 0.578 | 32300. |
| | | | | | 32700. |
| | | | | | 44250. |
| | | | | | 42250. |
| | | | | | 35350. |
| | | | | | 45550. |
| | | | | | 39700. |

| COORDINATE NUMBER | TASK ELIMINATED | RQPA | TASK | EXPANDED TECHNICAL VALUE | | TOTAL | COST | DELTA | RQPA ELIMINATED |
|-------------------|-----------------|------|----------|--------------------------|-----------|--------|------|-------|-----------------|
| | | | | DELTA | DELTA | | | | |
| 81 | 75 | 3 | 6436.459 | 0.727 | 12019500. | 44450. | 0 | | |
| 82 | 124 | 1 | 6435.883 | 0.576 | 11984350. | 35150. | 0 | | |
| 83 | 9 | 1 | 6435.160 | 0.723 | 11953300. | 31050. | 0 | | |
| 84 | 68 | 4 | 6434.392 | 0.768 | 11922500. | 30800. | 0 | | |
| 85 | 106 | 2 | 6433.899 | 0.493 | 11892450. | 30050. | 0 | | |
| 86 | 138 | 3 | 6433.356 | 0.542 | 11852800. | 39650. | 0 | | |
| 87 | 19 | 4 | 6432.661 | 0.695 | 11816350. | 36450. | 0 | | |
| 88 | 15 | 2 | 6431.546 | 1.116 | 11769550. | 46800. | 0 | | |
| 89 | 103 | 1 | 6430.511 | 1.034 | 11734100. | 35450. | 0 | | |
| 90 | 109 | 1 | 6430.187 | 0.324 | 11700200. | 33900. | 109 | | |
| 91 | 42 | 2 | 6429.587 | 0.600 | 11657650. | 42550. | 0 | | |
| 92 | 65 | 3 | 6427.962 | 1.625 | 11610300. | 47350. | 0 | | |
| 93 | 130 | 1 | 6426.589 | 1.373 | 11574600. | 35700. | 0 | | |
| 94 | 13 | 2 | 6425.837 | 0.752 | 11525550. | 49050. | 0 | | |
| 95 | 19 | 2 | 6424.440 | 1.397 | 11480750. | 44800. | 0 | | |
| 96 | 44 | 1 | 6423.669 | 0.771 | 11434300. | 46450. | 0 | | |
| 97 | 18 | 1 | 6422.829 | 0.840 | 11397300. | 37000. | 18 | | |
| 98 | 69 | 3 | 6421.338 | 1.492 | 11357550. | 39750. | 0 | | |
| 99 | 23 | 4 | 6420.697 | 0.640 | 11314600. | 42950. | 0 | | |
| 100 | 119 | 2 | 6419.618 | 1.079 | 11276800. | 37800. | 0 | | |
| 101 | 110 | 1 | 6418.756 | 0.862 | 11240400. | 36400. | 0 | | |
| 102 | 95 | 2 | 6418.024 | 0.732 | 11202200. | 38200. | 0 | | |
| 103 | 87 | 1 | 6417.114 | 0.911 | 11168550. | 33650. | 0 | | |
| 104 | 35 | 3 | 6415.760 | 1.354 | 11137600. | 30950. | 0 | | |
| 105 | 105 | 1 | 6414.230 | 1.530 | 11097000. | 40600. | 0 | | |
| 106 | 22 | 3 | 6413.116 | 1.114 | 11063650. | 33350. | 0 | | |
| 107 | 108 | 1 | 6411.423 | 1.693 | 11027700. | 35950. | 108 | | |
| 108 | 116 | 1 | 6410.353 | 1.070 | 10990450. | 37250. | 0 | | |
| 109 | 99 | 2 | 6409.051 | 1.302 | 10943400. | 47050. | 0 | | |
| 110 | 140 | 3 | 6407.643 | 1.408 | 10908800. | 36600. | 0 | | |
| 111 | 83 | 2 | 6406.509 | 1.134 | 10876600. | 32200. | 0 | | |
| 112 | 77 | 2 | 6405.057 | 1.452 | 10841400. | 35200. | 0 | | |
| 113 | 48 | 1 | 6403.827 | 1.230 | 10810800. | 30600. | 0 | | |
| 114 | 16 | 3 | 6402.221 | 1.606 | 10777900. | 32900. | 0 | | |
| 115 | 121 | 2 | 6400.031 | 2.189 | 10741850. | 36050. | 0 | | |
| 116 | 122 | 1 | 6398.281 | 1.750 | 10694650. | 47200. | 0 | | |
| 117 | 141 | 4 | 6396.198 | 2.083 | 10663200. | 31450. | 0 | | |
| 118 | 9 | 2 | 6394.553 | 1.645 | 10626150. | 37050. | 0 | | |
| 119 | 100 | 2 | 6393.809 | 0.744 | 10596100. | 30050. | 0 | | |
| 120 | 12 | 1 | 6391.169 | 2.640 | 10569400. | 46700. | 0 | | |

83

COORDINATE * TASK ELIMINATED * EXPECTED * MOPA ELIMINATED *
 NUMBER * MOPA TASK * TECHNICAL VALUE * TOTAL * COST * DELTA * MOPA * HBPA

| COORDINATE NUMBER | TASK ELIMINATED MOPA | TASK | EXPECTED TECHNICAL VALUE | TOTAL | COST | DELTA | MOPA ELIMINATED | HBPA |
|-------------------|----------------------|------|--------------------------|-------|-----------|--------|-----------------|------|
| 121 | 10 | 4 | 6389.293 | 1.876 | 10506950. | 42450. | 0 | 0 |
| 122 | 17 | 3 | 6387.303 | 1.990 | 10465050. | 41900. | 0 | 0 |
| 123 | 77 | 1 | 6386.671 | 0.632 | 10428300. | 36750. | 77 | 0 |
| 124 | 127 | 3 | 6384.737 | 1.934 | 10387500. | 40800. | 0 | 0 |
| 125 | 49 | 3 | 6382.927 | 1.810 | 10350700. | 36800. | 0 | 0 |
| 126 | 113 | 2 | 6381.190 | 1.737 | 10311950. | 38750. | 0 | 0 |
| 127 | 136 | 4 | 6378.663 | 2.528 | 10271850. | 40100. | 0 | 0 |
| 128 | 50 | 1 | 6377.859 | 0.803 | 10225600. | 46250. | 0 | 0 |
| 129 | 145 | 1 | 6375.666 | 2.194 | 10182100. | 43500. | 0 | 0 |
| 130 | 145 | 4 | 6374.194 | 1.472 | 10138600. | 43500. | 0 | 0 |
| 131 | 140 | 4 | 6371.699 | 2.495 | 10093400. | 45200. | 0 | 0 |
| 132 | 103 | 2 | 6370.884 | 0.814 | 10059900. | 33500. | 0 | 0 |
| 133 | 76 | 1 | 6369.463 | 1.422 | 10016150. | 43750. | 0 | 0 |
| 134 | 55 | 1 | 6368.276 | 1.187 | 9982600. | 33550. | 55 | 0 |
| 135 | 115 | 2 | 6365.054 | 2.422 | 9936850. | 45750. | 0 | 0 |
| 136 | 137 | 2 | 6364.012 | 1.842 | 9899650. | 37200. | 0 | 0 |
| 137 | 19 | 1 | 6362.032 | 1.980 | 9853400. | 46250. | 0 | 0 |
| 138 | 8 | 2 | 6359.921 | 2.111 | 9818100. | 35300. | 0 | 0 |
| 139 | 121 | 1 | 6358.078 | 1.843 | 9781250. | 36850. | 0 | 0 |
| 140 | 137 | 1 | 6356.759 | 1.319 | 9732500. | 48750. | 137 | 0 |
| 141 | 86 | 2 | 6354.823 | 1.936 | 9698350. | 34150. | 0 | 0 |
| 142 | 7 | 2 | 6353.646 | 1.177 | 9662450. | 35900. | 0 | 0 |
| 143 | 99 | 4 | 6352.247 | 1.398 | 9620250. | 42200. | 0 | 0 |
| 144 | 136 | 2 | 6349.770 | 2.477 | 9574100. | 46150. | 0 | 0 |
| 145 | 4 | 3 | 6346.660 | 3.110 | 9528450. | 45650. | 0 | 0 |
| 146 | 31 | 1 | 6344.110 | 2.550 | 9496650. | 31800. | 31 | 0 |
| 147 | 141 | 1 | 6341.853 | 2.253 | 9465400. | 31250. | 0 | 0 |
| 148 | 81 | 2 | 6338.844 | 3.008 | 9422550. | 42850. | 0 | 0 |
| 149 | 126 | 2 | 6337.382 | 1.462 | 9387900. | 34650. | 0 | 0 |
| 150 | 46 | 1 | 6334.743 | 2.639 | 9347100. | 40800. | 0 | 0 |
| 151 | 62 | 3 | 6332.341 | 2.402 | 9314750. | 32350. | 0 | 0 |
| 152 | 16 | 1 | 6328.474 | 3.867 | 9265700. | 49050. | 0 | 0 |
| 153 | 136 | 1 | 6324.721 | 3.753 | 9234250. | 31450. | 0 | 0 |
| 154 | 114 | 2 | 6321.897 | 2.824 | 9186700. | 47550. | 0 | 0 |
| 155 | 2 | 1 | 6317.601 | 4.296 | 9153900. | 32800. | 0 | 0 |
| 156 | 29 | 2 | 6314.529 | 3.072 | 9120050. | 33850. | 29 | 0 |
| 157 | 123 | 3 | 6310.118 | 4.411 | 9082800. | 37250. | 0 | 0 |
| 158 | 17 | 4 | 6307.762 | 2.356 | 9034000. | 48800. | 0 | 0 |
| 159 | 117 | 3 | 6305.083 | 2.680 | 8999600. | 34400. | 0 | 0 |
| 160 | 20 | 1 | 6301.597 | 3.485 | 8952900. | 46700. | 0 | 0 |

COORDINATE NUMBER TASK ELIMINATED RECEIVED TECHNICAL VALUE COST DELTA HOPA ELIMINATE

| COORDINATE NUMBER | TASK ELIMINATED HOPA | TASK | TOTAL | DELTA | TOTAL | COST | DELTA | HOPA ELIMINATE HOPA |
|-------------------|----------------------|------|----------|-------|----------|--------|-------|---------------------|
| 161 | 80 | 3 | 6298.783 | 2.814 | 8914200. | 38700. | 0 | 0 |
| 162 | 124 | 2 | 6296.498 | 2.285 | 8882450. | 31750. | 0 | 0 |
| 163 | 84 | 2 | 6294.604 | 2.094 | 8840700. | 41750. | 0 | 0 |
| 164 | 4 | 2 | 6291.179 | 3.225 | 8799450. | 41250. | 0 | 0 |
| 165 | 79 | 1 | 6287.971 | 3.207 | 8765950. | 33500. | 0 | 0 |
| 166 | 26 | 2 | 6284.754 | 3.217 | 8722000. | 43950. | 0 | 0 |
| 167 | 116 | 3 | 6280.782 | 3.972 | 8677000. | 45000. | 0 | 0 |
| 168 | 142 | 2 | 6277.736 | 3.046 | 8646400. | 30600. | 25 | 0 |
| 169 | 25 | 1 | 6274.637 | 3.099 | 8613900. | 32500. | 0 | 0 |
| 170 | 85 | 1 | 6273.249 | 1.388 | 8582750. | 31150. | 0 | 0 |
| 171 | 113 | 3 | 6270.392 | 2.856 | 8550550. | 32200. | 0 | 0 |
| 172 | 62 | 1 | 6265.189 | 5.203 | 8514800. | 35750. | 0 | 0 |
| 173 | 15 | 1 | 6260.561 | 4.627 | 8464900. | 49900. | 15 | 0 |
| 174 | 42 | 1 | 6256.353 | 4.208 | 8423150. | 41750. | 0 | 0 |
| 175 | 148 | 1 | 6250.641 | 5.712 | 8377550. | 45600. | 148 | 0 |
| 176 | 39 | 4 | 6245.691 | 4.951 | 8342050. | 35500. | 0 | 0 |
| 177 | 78 | 2 | 6239.892 | 5.799 | 8311200. | 30850. | 78 | 0 |
| 178 | 48 | 2 | 6237.644 | 2.248 | 8267450. | 43750. | 48 | 0 |
| 179 | 37 | 2 | 6232.318 | 5.326 | 8227200. | 40250. | 0 | 0 |
| 180 | 139 | 1 | 6228.462 | 3.856 | 8187000. | 39550. | 0 | 0 |
| 181 | 129 | 1 | 6223.157 | 5.305 | 8143000. | 44000. | 129 | 0 |
| 182 | 75 | 1 | 6220.065 | 3.092 | 8100200. | 43450. | 0 | 0 |
| 183 | 12 | 3 | 6211.625 | 8.439 | 8062850. | 37350. | 0 | 0 |
| 184 | 30 | 3 | 6205.923 | 5.703 | 8018100. | 44750. | 0 | 0 |
| 185 | 22 | 1 | 6201.956 | 3.967 | 7983200. | 34900. | 0 | 0 |
| 186 | 2 | 4 | 6195.985 | 5.971 | 7953100. | 30100. | 2 | 0 |
| 187 | 114 | 4 | 6191.973 | 4.011 | 7908800. | 44300. | 0 | 0 |
| 188 | 104 | 1 | 6188.117 | 3.856 | 7872950. | 35850. | 0 | 0 |
| 189 | 63 | 1 | 6184.557 | 3.561 | 7840700. | 32250. | 63 | 0 |
| 190 | 13 | 1 | 6179.818 | 4.738 | 7797550. | 43150. | 0 | 0 |
| 191 | 75 | 2 | 6171.365 | 8.454 | 7763500. | 34050. | 0 | 0 |
| 192 | 26 | 3 | 6166.172 | 5.193 | 7731050. | 32450. | 0 | 0 |
| 193 | 119 | 1 | 6158.381 | 7.791 | 7696000. | 35050. | 119 | 0 |
| 194 | 115 | 3 | 6153.081 | 5.299 | 7648150. | 47850. | 0 | 0 |
| 195 | 35 | 2 | 6146.100 | 6.981 | 7603350. | 44800. | 0 | 0 |
| 196 | 81 | 1 | 6140.674 | 5.426 | 7567400. | 35950. | 81 | 0 |
| 197 | 114 | 3 | 6136.116 | 4.558 | 7519850. | 47550. | 0 | 0 |
| 198 | 23 | 2 | 6130.810 | 5.306 | 7472600. | 47250. | 0 | 0 |
| 199 | 120 | 1 | 6127.478 | 3.332 | 7439700. | 32900. | 120 | 0 |
| 200 | 138 | 2 | 6125.336 | 2.141 | 7406650. | 33050. | 138 | 0 |

COORDINATE * TASK ELIMINATED * NOPA ELIMINATION

NUMBER * NOPA * DELTA * MBPA

EXPICIT TECHNICAL VALUE * COST

TASK * DELTA * TOTAL * TOTAL

| COORDINATE NUMBER | TASK ELIMINATED NOPA | TASK | TECHNICAL VALUE TOTAL | DELTA | COST TOTAL | DELTA | NOPA ELIMINATION MBPA |
|-------------------|----------------------|------|-----------------------|--------|------------|--------|-----------------------|
| 201 | 107 | 1 | 6115.932 | 9.404 | 7369050. | 37600. | 107 |
| 202 | 96 | 2 | 6107.141 | 8.791 | 7322050. | 47000. | 0 |
| 203 | 71 | 2 | 6101.986 | 5.155 | 7280300. | 41750. | 0 |
| 204 | 92 | 3 | 6096.439 | 5.546 | 7246600. | 33700. | 0 |
| 205 | 127 | 1 | 6087.912 | 8.527 | 7199000. | 47600. | 0 |
| 206 | 62 | 2 | 6076.337 | 11.575 | 7154650. | 44350. | 62 |
| 207 | 36 | 1 | 6067.261 | 9.075 | 7118400. | 36250. | 36 |
| 208 | 149 | 1 | 6060.636 | 6.625 | 7085700. | 32700. | 149 |
| 209 | 86 | 1 | 6053.496 | 7.140 | 7040900. | 44800. | 86 |
| 210 | 141 | 2 | 6047.414 | 6.082 | 7003000. | 37900. | 0 |
| 211 | 127 | 4 | 6042.561 | 4.854 | 6970300. | 32700. | 0 |
| 212 | 134 | 1 | 6035.963 | 6.597 | 6936850. | 33450. | 0 |
| 213 | 97 | 2 | 6029.128 | 6.835 | 6906250. | 30600. | 0 |
| 214 | 83 | 1 | 6020.904 | 8.224 | 6875100. | 31150. | 83 |
| 215 | 34 | 2 | 6017.571 | 3.333 | 6834250. | 40850. | 34 |
| 216 | 94 | 4 | 6006.194 | 11.377 | 6801750. | 32500. | 0 |
| 217 | 37 | 4 | 5996.595 | 9.600 | 6770200. | 31550. | 0 |
| 218 | 144 | 1 | 5983.225 | 13.369 | 6738400. | 31800. | 144 |
| 219 | 95 | 4 | 5974.277 | 8.948 | 6695400. | 43000. | 0 |
| 220 | 79 | 4 | 5963.809 | 10.468 | 6659300. | 36100. | 0 |
| 221 | 122 | 2 | 5957.411 | 6.398 | 6612700. | 46600. | 0 |
| 222 | 7 | 1 | 5953.539 | 3.872 | 6568100. | 44600. | 0 |
| 223 | 115 | 1 | 5944.355 | 9.184 | 6537850. | 30250. | 0 |
| 224 | 111 | 2 | 5940.445 | 3.909 | 6507800. | 30050. | 0 |
| 225 | 69 | 1 | 5934.733 | 5.713 | 6469250. | 38550. | 69 |
| 226 | 127 | 2 | 5918.816 | 15.917 | 6420100. | 49150. | 127 |
| 227 | 98 | 1 | 5915.278 | 3.538 | 6389450. | 30650. | 0 |
| 228 | 65 | 2 | 5909.357 | 5.922 | 6353050. | 36400. | 0 |
| 229 | 56 | 3 | 5905.125 | 4.231 | 6321700. | 31350. | 56 |
| 230 | 154 | 2 | 5897.740 | 7.385 | 6291250. | 30450. | 154 |
| 231 | 13 | 3 | 5890.991 | 6.749 | 6261100. | 30150. | 13 |
| 232 | 95 | 3 | 5887.312 | 3.679 | 6227100. | 34000. | 0 |
| 233 | 110 | 2 | 5880.330 | 6.982 | 6192950. | 34150. | 110 |
| 234 | 72 | 1 | 5875.253 | 5.077 | 6160950. | 32000. | 72 |
| 235 | 10 | 1 | 5868.397 | 6.855 | 6124200. | 36750. | 0 |
| 236 | 54 | 4 | 5859.619 | 8.778 | 6075050. | 49150. | 0 |
| 237 | 9 | 3 | 5847.092 | 12.527 | 6029950. | 45100. | 0 |
| 238 | 73 | 1 | 5827.979 | 19.113 | 5982950. | 47000. | 0 |
| 239 | 130 | 4 | 5817.317 | 10.662 | 5934000. | 48950. | 0 |
| 240 | 87 | 2 | 5811.816 | 5.500 | 5902200. | 31800. | 87 |

EXHIBIT

COORDINATE NUMBER * TASK ELIMINATED * HSPA TASK * TECHNICAL VALUE * TOTAL * COST * DELTA * HSPA ELIMINATED * HSPA

| COORDINATE NUMBER | TASK ELIMINATED | HSPA TASK | TECHNICAL VALUE | TOTAL | COST | DELTA | HSPA ELIMINATED |
|-------------------|-----------------|-----------|-----------------|--------|----------|--------|-----------------|
| 241 | 125 | 1 | 5893.671 | 8.145 | 5860850. | 41350. | 125 |
| 242 | 115 | 4 | 5785.807 | 17.863 | 5814550. | 46300. | 115 |
| 243 | 94 | 3 | 5778.645 | 7.163 | 5777850. | 36700. | 0 |
| 244 | 66 | 1 | 5772.869 | 5.776 | 5728900. | 48950. | 0 |
| 245 | 64 | 3 | 5765.761 | 7.109 | 5687050. | 41850. | 64 |
| 246 | 118 | 1 | 5756.987 | 8.774 | 5656200. | 30850. | 0 |
| 247 | 58 | 2 | 5752.068 | 4.919 | 5615700. | 40500. | 58 |
| 248 | 150 | 2 | 5742.046 | 10.022 | 5578250. | 37650. | 0 |
| 249 | 111 | 1 | 5735.382 | 6.663 | 5543350. | 34700. | 111 |
| 250 | 39 | 3 | 5717.835 | 17.547 | 5497600. | 45750. | 0 |
| 251 | 38 | 1 | 5711.113 | 6.722 | 5460350. | 37250. | 0 |
| 252 | 132 | 1 | 5697.982 | 13.131 | 5430350. | 30000. | 0 |
| 253 | 41 | 1 | 5691.635 | 6.347 | 5381900. | 48450. | 41 |
| 254 | 143 | 3 | 5674.657 | 16.978 | 5351350. | 30550. | 0 |
| 255 | 24 | 1 | 5669.337 | 5.320 | 5313050. | 38300. | 0 |
| 256 | 26 | 1 | 5657.950 | 11.387 | 5267100. | 45950. | 0 |
| 257 | 73 | 2 | 5650.983 | 6.966 | 5217300. | 49800. | 0 |
| 258 | 40 | 4 | 5646.485 | 4.498 | 5185650. | 31650. | 0 |
| 259 | 147 | 2 | 5640.068 | 6.417 | 5150700. | 34950. | 0 |
| 260 | 43 | 2 | 5630.626 | 9.442 | 5105100. | 45600. | 43 |
| 261 | 49 | 1 | 5620.986 | 9.639 | 5060900. | 44200. | 49 |
| 262 | 59 | 1 | 5609.639 | 11.347 | 5014350. | 46550. | 59 |
| 263 | 7 | 3 | 5588.229 | 21.410 | 4973650. | 40700. | 7 |
| 264 | 26 | 4 | 5576.367 | 11.862 | 4931500. | 42150. | 26 |
| 265 | 3 | 1 | 5569.822 | 6.545 | 4890000. | 41500. | 3 |
| 266 | 145 | 3 | 5546.476 | 23.345 | 4849150. | 40850. | 0 |
| 267 | 131 | 1 | 5533.911 | 12.565 | 4816250. | 32900. | 131 |
| 268 | 5 | 2 | 5527.881 | 6.031 | 4779850. | 36400. | 0 |
| 269 | 37 | 1 | 5513.730 | 14.150 | 4749200. | 30650. | 0 |
| 270 | 68 | 3 | 5494.050 | 19.680 | 4705750. | 43450. | 0 |
| 271 | 133 | 1 | 5486.011 | 8.038 | 4673700. | 32050. | 133 |
| 272 | 99 | 3 | 5459.240 | 26.771 | 4630150. | 43550. | 0 |
| 273 | 106 | 3 | 5451.529 | 7.711 | 4589150. | 41000. | 0 |
| 274 | 116 | 2 | 5427.097 | 24.432 | 4547000. | 41450. | 116 |
| 275 | 101 | 3 | 5407.651 | 19.446 | 4512800. | 34900. | 0 |
| 276 | 45 | 2 | 5390.233 | 17.418 | 4467600. | 45200. | 0 |
| 277 | 123 | 2 | 5374.086 | 15.247 | 4436050. | 31550. | 0 |
| 278 | 124 | 4 | 5365.465 | 9.521 | 4388000. | 47250. | 124 |
| 279 | 33 | 1 | 5343.274 | 22.190 | 4349550. | 39250. | 33 |
| 280 | 38 | 2 | 5330.007 | 13.267 | 4311850. | 37700. | 38 |

5

| COORDINATE NUMBER | TASK ELIMINATED | HOPA | EXPECIFIED | | TOTAL | COST | DELTA | HOPA ELIMINATED |
|-------------------|-----------------|------|-----------------|--------|----------|--------|-------|-----------------|
| | | | TECHNICAL VALUE | DELTA | | | | |
| 281 | 146 | 2 | 5306.420 | 23.587 | 4264150. | 47700. | 0 | |
| 282 | 22 | 2 | 5285.092 | 21.328 | 4222550. | 41600. | 22 | |
| 283 | 1 | 2 | 5263.868 | 21.224 | 4187150. | 35400. | 1 | |
| 284 | 65 | 4 | 5243.186 | 20.682 | 4154550. | 32600. | 0 | |
| 285 | 82 | 2 | 5236.443 | 6.743 | 4123550. | 31000. | 0 | |
| 286 | 88 | 2 | 5222.897 | 13.566 | 4085400. | 38150. | 0 | |
| 287 | 112 | 1 | 5204.906 | 17.991 | 4055400. | 30000. | 112 | |
| 288 | 79 | 3 | 5180.492 | 24.505 | 4013750. | 41650. | 79 | |
| 289 | 98 | 2 | 5159.384 | 21.018 | 3974550. | 39200. | 98 | |
| 290 | 47 | 1 | 5148.910 | 10.474 | 3932500. | 42050. | 0 | |
| 291 | 150 | 1 | 5135.293 | 13.617 | 3895700. | 36800. | 0 | |
| 292 | 30 | 2 | 5114.731 | 20.563 | 3849600. | 46100. | 0 | |
| 293 | 44 | 3 | 5095.691 | 19.039 | 3817800. | 31800. | 44 | |
| 294 | 102 | 1 | 5076.647 | 19.044 | 3787000. | 30800. | 0 | |
| 295 | 139 | 2 | 5052.030 | 24.617 | 3737800. | 49200. | 139 | |
| 296 | 6 | 1 | 5032.589 | 19.440 | 3705400. | 32400. | 6 | |
| 297 | 147 | 1 | 5008.898 | 23.691 | 3673400. | 32000. | 0 | |
| 298 | 117 | 1 | 4984.232 | 24.666 | 3627150. | 46250. | 117 | |
| 299 | 150 | 3 | 4961.021 | 23.211 | 3577400. | 49750. | 150 | |
| 300 | 100 | 1 | 4933.549 | 27.473 | 3540100. | 37300. | 100 | |
| 301 | 141 | 3 | 4917.460 | 16.089 | 3504550. | 35550. | 141 | |
| 302 | 5 | 3 | 4907.409 | 10.051 | 3472300. | 32250. | 0 | |
| 303 | 19 | 3 | 4882.023 | 25.386 | 3428650. | 43650. | 19 | |
| 304 | 99 | 1 | 4849.969 | 32.054 | 3397650. | 31000. | 99 | |
| 305 | 45 | 1 | 4826.929 | 23.040 | 3353600. | 44050. | 45 | |
| 306 | 103 | 3 | 4816.748 | 10.181 | 3322600. | 31000. | 103 | |
| 307 | 97 | 1 | 4791.618 | 25.130 | 3282400. | 40200. | 0 | |
| 308 | 123 | 1 | 4750.614 | 41.003 | 3251750. | 30650. | 123 | |
| 309 | 165 | 2 | 4728.587 | 22.027 | 3203150. | 40600. | 145 | |
| 310 | 17 | 2 | 4715.498 | 13.090 | 3165400. | 37750. | 0 | |
| 311 | 54 | 3 | 4690.177 | 25.321 | 3121550. | 43850. | 54 | |
| 312 | 94 | 1 | 4671.328 | 18.849 | 3091500. | 30050. | 0 | |
| 313 | 113 | 1 | 4659.426 | 11.902 | 3058450. | 33050. | 113 | |
| 314 | 16 | 2 | 4617.222 | 42.204 | 3012200. | 46250. | 16 | |
| 315 | 166 | 1 | 4584.094 | 33.127 | 2979100. | 33100. | 146 | |
| 316 | 126 | 1 | 4556.679 | 27.416 | 2935700. | 43400. | 126 | |
| 317 | 88 | 3 | 4530.118 | 26.561 | 2894350. | 41350. | 0 | |
| 318 | 102 | 4 | 4493.641 | 36.476 | 2847300. | 47050. | 0 | |
| 319 | 9 | 4 | 4454.473 | 39.168 | 2807900. | 39400. | 9 | |
| 320 | 84 | 3 | 4434.839 | 19.634 | 2761100. | 46800. | 0 | |

COORDINATE NUMBER * TASK ELIMINATED * HBPA * TASK * TECHNICAL VALUE * DELTA * COST * TOTAL * DELTA * HBPA ELIMINATED * HBPA

| COORDINATE NUMBER | TASK ELIMINATED HBPA | TASK | TECHNICAL VALUE | DELTA | COST | TOTAL | DELTA | HBPA ELIMINATED HBPA |
|-------------------|----------------------|------|-----------------|--------|----------|----------|--------|----------------------|
| 321 | 73 | 3 | 4393.690 | 41.149 | 2727600. | 2727600. | 34100. | 73 |
| 322 | 91 | 1 | 4359.418 | 34.272 | 2679100. | 2679100. | 47900. | 91 |
| 323 | 95 | 1 | 4341.221 | 18.396 | 2637750. | 2637750. | 41350. | 95 |
| 324 | 101 | 2 | 4326.806 | 14.215 | 2606950. | 2606950. | 30800. | 0 |
| 325 | 94 | 2 | 4307.172 | 19.634 | 2565050. | 2565050. | 41900. | 94 |
| 326 | 105 | 3 | 4280.681 | 26.491 | 2532950. | 2532950. | 32100. | 0 |
| 327 | 4 | 1 | 4258.284 | 22.398 | 2487050. | 2487050. | 45900. | 4 |
| 328 | 106 | 1 | 4232.582 | 25.702 | 2438400. | 2438400. | 48650. | 106 |
| 329 | 97 | 3 | 4212.948 | 19.633 | 2402400. | 2402400. | 36000. | 97 |
| 330 | 51 | 3 | 4167.874 | 45.074 | 2359850. | 2359850. | 42550. | 51 |
| 331 | 30 | 1 | 4139.315 | 28.559 | 2310300. | 2310300. | 49550. | 30 |
| 332 | 68 | 2 | 4098.695 | 40.620 | 2268950. | 2268950. | 41350. | 68 |
| 333 | 93 | 1 | 4071.565 | 27.130 | 2222300. | 2222300. | 46650. | 93 |
| 334 | 101 | 1 | 4031.585 | 39.980 | 2187000. | 2187000. | 35300. | 101 |
| 335 | 70 | 1 | 3971.294 | 60.291 | 2140450. | 2140450. | 46550. | 70 |
| 336 | 60 | 1 | 3942.203 | 29.091 | 2096450. | 2096450. | 44000. | 60 |
| 337 | 21 | 1 | 3921.005 | 21.196 | 2064500. | 2064500. | 31950. | 21 |
| 338 | 80 | 1 | 3891.387 | 29.619 | 2020050. | 2020050. | 44450. | 80 |
| 339 | 132 | 2 | 3869.791 | 21.596 | 1989550. | 1989550. | 30500. | 132 |
| 340 | 75 | 4 | 3803.827 | 65.964 | 1957450. | 1957450. | 32100. | 75 |
| 341 | 8 | 1 | 3776.338 | 27.490 | 1919350. | 1919350. | 38100. | 8 |
| 342 | 32 | 1 | 3727.184 | 49.154 | 1880300. | 1880300. | 39050. | 32 |
| 343 | 39 | 1 | 3698.624 | 28.560 | 1840850. | 1840850. | 39450. | 39 |
| 344 | 102 | 3 | 3674.626 | 21.998 | 1809450. | 1809450. | 31400. | 102 |
| 345 | 46 | 2 | 3637.971 | 36.655 | 1762450. | 1762450. | 47000. | 46 |
| 346 | 23 | 3 | 3600.736 | 37.235 | 1715450. | 1715450. | 47000. | 23 |
| 347 | 162 | 4 | 3565.037 | 35.699 | 1670800. | 1670800. | 44650. | 162 |
| 348 | 82 | 1 | 3531.323 | 33.715 | 1629100. | 1629100. | 41700. | 82 |
| 349 | 61 | 1 | 3473.789 | 57.534 | 1580100. | 1580100. | 49000. | 61 |
| 350 | 52 | 1 | 3410.200 | 63.589 | 1535900. | 1535900. | 44200. | 52 |
| 351 | 96 | 1 | 3367.358 | 42.042 | 1488300. | 1488300. | 47600. | 96 |
| 352 | 40 | 1 | 3322.375 | 44.983 | 1438800. | 1438800. | 49500. | 40 |
| 353 | 89 | 1 | 3293.819 | 28.556 | 1407950. | 1407950. | 30850. | 89 |
| 354 | 90 | 1 | 3248.836 | 44.983 | 1360100. | 1360100. | 47850. | 90 |
| 355 | 5 | 1 | 3211.145 | 37.691 | 1320200. | 1320200. | 39900. | 5 |
| 356 | 122 | 3 | 3171.160 | 39.985 | 1282050. | 1282050. | 38150. | 122 |
| 357 | 76 | 2 | 3117.846 | 53.314 | 1233550. | 1233550. | 48500. | 76 |
| 358 | 17 | 1 | 3068.760 | 49.086 | 1189800. | 1189800. | 43750. | 17 |
| 359 | 121 | 4 | 3030.360 | 38.400 | 1157250. | 1157250. | 32550. | 121 |
| 360 | 35 | 1 | 2975.820 | 54.540 | 1112750. | 1112750. | 44500. | 35 |

20

COORDINATE TASK ELIMINATED TECHNICAL VALUE COST MBPA ELIMINATED

| NUMBER | MBPA | TASK | TOTAL DELTA | TOTAL | DELTA | MBPA |
|--------|------|------|-------------|----------|--------|------|
| 360 | 35 | 1 | 2975.820 | 1112750. | 44500. | 35 |
| 361 | 92 | 2 | 2917.438 | 1065550. | 47200. | 92 |
| 362 | 140 | 1 | 2852.463 | 1017750. | 47800. | 140 |
| 363 | 66 | 3 | 2794.707 | 977200. | 40550. | 66 |
| 364 | 105 | 2 | 2692.820 | 935550. | 41650. | 105 |
| 365 | 147 | 4 | 2623.548 | 889100. | 46450. | 147 |
| 366 | 20 | 2 | 2511.075 | 849950. | 39150. | 20 |
| 367 | 14 | 1 | 2417.587 | 819850. | 30100. | 14 |
| 368 | 84 | 1 | 2368.501 | 789250. | 30500. | 84 |
| 369 | 118 | 3 | 2307.571 | 751750. | 37500. | 118 |
| 370 | 88 | 1 | 2252.236 | 718900. | 32850. | 88 |
| 371 | 85 | 2 | 2186.292 | 682450. | 36450. | 85 |
| 372 | 27 | 2 | 2131.287 | 652400. | 30050. | 27 |
| 373 | 67 | 1 | 2053.080 | 613400. | 39000. | 67 |
| 374 | 74 | 1 | 1943.422 | 566100. | 47300. | 74 |
| 375 | 50 | 2 | 1867.109 | 533550. | 32550. | 50 |
| 376 | 134 | 2 | 1775.482 | 495150. | 38400. | 134 |
| 377 | 47 | 2 | 1670.746 | 452300. | 42850. | 47 |
| 378 | 136 | 3 | 1579.119 | 415700. | 36600. | 136 |
| 379 | 24 | 3 | 1472.717 | 378250. | 37450. | 24 |
| 380 | 143 | 1 | 1379.635 | 346100. | 32150. | 143 |
| 381 | 53 | 1 | 1248.214 | 305950. | 40150. | 53 |
| 382 | 10 | 3 | 1133.957 | 273050. | 32900. | 10 |
| 383 | 65 | 1 | 952.537 | 223450. | 49600. | 65 |
| 384 | 42 | 3 | 835.641 | 191850. | 31600. | 42 |
| 385 | 130 | 3 | 659.045 | 151350. | 40500. | 130 |
| 386 | 114 | 1 | 517.106 | 114850. | 36500. | 114 |
| 387 | 37 | 3 | 377.464 | 83150. | 31700. | 37 |
| 388 | 12 | 2 | 171.832 | 36850. | 46300. | 12 |
| 389 | 71 | 4 | -0.013 | 0. | 35850. | 71 |

87