

EXPERIMENTAL STUDY PROGRAM TO
INVESTIGATE LIMITATIONS IN FOURIER SPECTROSCOPY

Isaiah Coleman

and

Lawrence N. Mertz

Block Engineering, Inc.
19 Blackstone Street
Cambridge, Massachusetts 02139

Contract No: F19628-67-C-0167

Project No: 8663

Task No: 866305

Work Unit No: 86630501

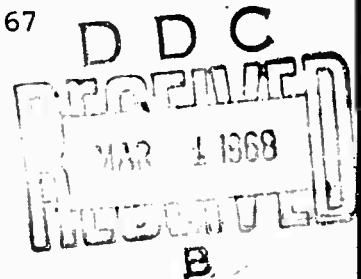

FINAL REPORT

Period Covered: January, 1967 thru 2 January, 1968

Date of Report: January, 1968

Contract Monitor: George A. Vanasse,
Optical Physics Laboratory

Prepared For:

AIR FORCE CAMBRIDGE RESEARCH LABORATORIES
OFFICE OF AEROSPACE RESEARCH
UNITED STATES AIR FORCE
BEDFORD, MASSACHUSETTS

This research was supported by the Advanced Research
Projects Agency, under ARPA Order No. 450

Block Engineering, Inc.
CAMBRIDGE 39, MASSACHUSETTS

Distribution of this document is unlimited. It may
be released to the Clearinghouse, Department of
Commerce, for sale to the general public.

AD 665890

EXPERIMENTAL STUDY PROGRAM TO
INVESTIGATE LIMITATIONS IN FOURIER SPECTROSCOPY

Isaiah Coleman

and

Lawrence N. Mertz

Block Engineering, Inc.
19 Blackstone Street
Cambridge, Massachusetts 02139

Contract No: F19 68-67-C-0167

Project No: 8663

Task No: 866305

Work Unit No: 86630501

FINAL REPORT

Period Covered: January, 1967 thru 2 January, 1968

Date of Report: January, 1968

Contract Monitor: George A. Vanasse,
Optical Physics Laboratory

Prepared For:

AIR FORCE CAMBRIDGE RESEARCH LABORATORIES
OFFICE OF AEROSPACE RESEARCH
UNITED STATES AIR FORCE
BEDFORD, MASSACHUSETTS

This research was supported by the Advanced Research
Projects Agency, under ARPA Order No. 450

Distribution of this document is unlimited. It may
be released to the Clearinghouse, Department of
Commerce, for sale to the general public.

TABLE OF CONTENTS

ABSTRACT

SECTION I INTRODUCTION 1

SECTION II DYNAMIC RANGE REQUIREMENTS 2

SECTION III BANDWIDTH MANIPULATION 6

Dynamic Range - Bandwidth Trade-off. 6

Interferogram Bandwidth. 6

Required Measurement Time. 8

Multiple Scanning. 9

Examples 9

Interferogram Averaging. 10

SECTION IV DIFFERENTIAL TECHNIQUES. 12

Differential Interferograms. 12

Complementary Outputs. 12

Dual Inputs. 13

Natural Differential Interferograms. 16

SECTION V SIGNAL COMPRESSION 17

Logarithmic Amplification. 17

Gain Changing. 19

Experimental Simulations 21

Table of Contents Continued

SECTION VI CHIRPING TECHNIQUES 31

Chirping. 31

Shape of the Central Fringes. 31

Experimental Simulation 33

On The Reduction of Extremely Chirped
Interferograms 34

Experimental Results. 46

Phase Correction. 55

Describing the Reference Phase. 58

SECTION VII FINAL COMMENT 60

APPENDIX. 61

LIST OF REFERENCE 62

LIST OF FIGURES

Figure 1 Mean S/N in Spectrum vs. Peak S/N in
Interferogram, in Terms of N Resolved
Spectral Elements 3

Figure 2 Michelson Interferometer for Fourier
Spectrometry. 7

Figure 3 Complementary Outputs of Lossless
Michelson Interferometer. 14

Figure 4 Analytic Signal Compression 18

Figure 5 Linear Segmented Signal Compression 18

Figure 6 Interferogram, Spectrum Adopted for
Simulations 22

List of Figures Continued

Figure 7	Interferogram, Spectrum Employing 60dB Channel.	23
Figure 8	Interferogram, Spectrum Employing 50dB Channel.	24
Figure 9	Interferogram, Spectrum Employing 40dB Channel.	25
Figure 10	Interferogram, Spectrum Employing 30dB Channel.	26
Figure 11	Interferogram, Spectrum Employing Cube Root Channel	27
Figure 12	Interferogram, Spectrum Employing Sectional Gain Change	29
Figure 13	Interferogram, Spectrum Employing Chirping	35
Figure 14	Central Fringe Position Relative to Truncation Boxcar for Various Offsets.	37
Figure 15	Spectral Transfer Functions for Various Offsets With No Apodization.	38
Figure 16	Spectral Transfer Functions for Various Offsets With Triangular Apodization.	39
Figure 17	Spectral Transfer Functions for Various Offsets With Half Cosine Wave Apodization	40
Figure 18	Spectral Transfer Functions for Various Offsets With Trapezoidal Apodization	41
Figure 18A	Display Format of Phase and Amplitude Spectra.	44
Figure 19	Wavelength Versus Central Fringe Position for Actual Chirped Interferometer	48

List of Figures Continued

Figure 19A	Chirped Interferogram of Acetylene Flame Source.	49
Figure 20	Amplitude, Phase Spectra With No Apod- ization	50
Figure 21	Phase Corrected Spectrum.	51
Figure 22	Spectrum From Trapezoidal Apodization, Equalized	52
Figure 23	Spectrum From Two-Dimensional Apodiza- tion.	53
Figure 24	Spectral Transfer Functions For Bands Near 3400 cm^{-1}	54

ABSTRACT

Fourier spectrometry is at a disadvantage compared to conventional scanners insofar as larger dynamic range is required for recording and/or transmitting the signal. Various procedures for minimizing the disadvantage are evaluated. A simulated experimental comparison is made between signal compression techniques and chirping (distribution of the central fringes of an interferogram). The comparison yields approximately a 15 dB improvement for both procedures, though each leave somewhat different residual distortions of the spectrum. The emphasis is given to the chirping procedure, since this is less well known, and ascendance over its problems provides greater insight into Fourier spectrometry.

SECTION I

INTRODUCTION

A recurring problem in the implementation of Fourier spectrometry has been the high precision required for the recording of interferograms. This results from the fact that interferograms usually have a much greater dynamic range (peak signal-to-noise ratio) than the spectra to which they correspond. Although the problem is most severe in systems where telemetry is employed, dynamic range can pose a limitation in laboratory and field experiments as well.

SECTION II
DYNAMIC RANGE REQUIREMENTS

Any device used to transmit, record or in any way process an interferogram must have a dynamic range capability at least equal to the dynamic range of the interferogram if no information is to be lost. The expression¹ relating interferogram dynamic range to the mean spectral signal-to-noise ratio is

$$\text{Dynamic range} = I_0/M_I = \sqrt{N} \sqrt{\Delta\nu_s/\Delta\nu_m} \frac{\bar{S}}{M_s} \quad (1)$$

where I_0 is the peak-to-peak amplitude of the envelope of the central fringes of the interferogram, \bar{S} the mean spectral amplitude, N the number of spectral resolution elements, and M_I and M_s the root mean square noise on the interferogram and spectrum respectively. $\Delta\nu_s$ and $\Delta\nu_m$ are respectively the frequency range of the spectral information and that of the noise. Since the system bandwidth need not be greater than that necessary to process the signal, $\Delta\nu_s/\Delta\nu_m$ will be considered unity. Figure 1 depicts equation (1) for a range of resolving powers.

Typical dynamic range requirements have ranges from about 10^3 to 10^4 . The spectrometer described by the Connes² resolves

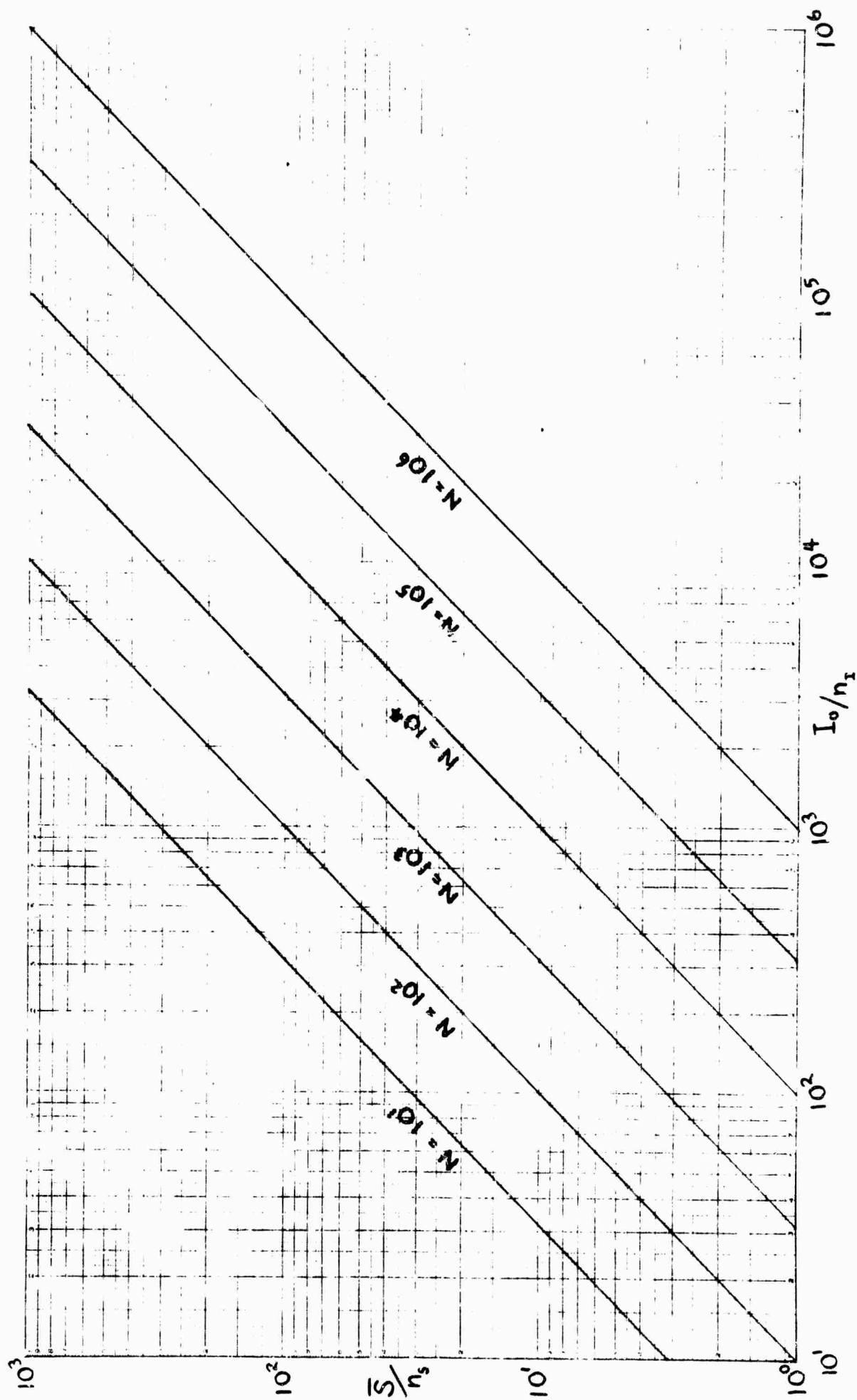

Fig. 1 Mean S/n in spectrum vs. peak S/n in interferogram, in terms of N resolved spectral elements.

on the order of 10^5 spectral elements and can record interferograms with a dynamic range of 10^6 . From figure 1 we conclude that the mean signal-to-noise ratio possible with that instrument is well in excess of 1000.

In cases where the dynamic range is limited by digitizing noise equation (1) may not be applicable. The reason is that digitizing noise can affect interferograms in a highly systematic manner. For example, in a system limited by digitizing noise it is always possible that some fringes lie below the digitizing threshold. The consequences can range from premature truncation of the interferogram to the production of blank segments. Premature truncation results in a loss of spectral resolving power while the presence of blank segments can totally destroy the instrumental profile. On the other hand, if the weak fringes happen to lie just at the digitizing threshold, then they are unduly amplified. To prevent such difficulties it is essential that the random interferogram noise be greater than the least significant digit.

Equation (1) determines the dynamic range necessary where a single ordinary interferogram is used to compute the spectrum. Interferogram processing devices need not process only one interferogram per spectrum, and interferograms can be of types other than ordinary. The following sections deal

with these topics.

SECTION III
BANDWIDTH MANIPULATION

Dynamic Range - Bandwidth Trade-off:

A situation is often encountered in which an interferogram processing device of limited dynamic range possesses a surplus of available bandwidth. In such cases full use of the available bandwidth will substantially reduce dynamic range requirements. Before presenting this procedure, a discussion of interferogram bandwidth (including a brief review of Fourier spectrometer) is in order

Interferogram Bandwidth:

Figure 2 represents a typical Fourier spectrometer configuration. Assume that the moving mirror is uniformly^{*} translated such that in time T the path difference between the two interferometer beams has varied around zero over a range $\pm \Delta\tau/2$. For each spectral component of the incident radiation of frequency $\nu \text{ cm}^{-1}$, the detector experiences $\nu\Delta\tau$ cycles of sinusoidal modulation in time T. An electrical frequency f corresponding to $\nu \text{ cm}^{-1}$ is thus produced by the detector according to

$$f = \nu\Delta\tau/T \text{ Hz} . \quad (2)$$

* The difference between continuous scanning and step-by-step scanning is slight in this context. Refer to reference 1 for a discussion of this topic.

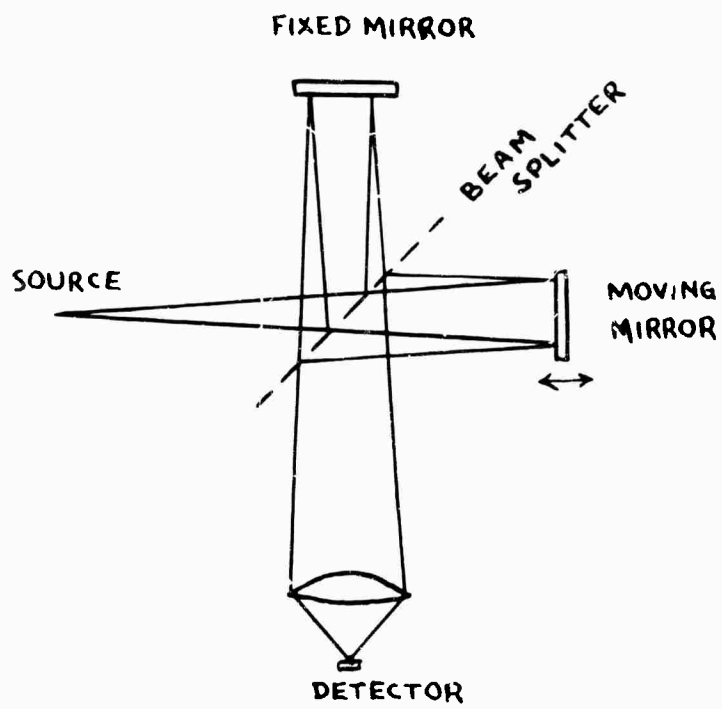

Fig. 2 Michelson interferometer for Fourier spectrometry.

Since the spectral resolution is given by

$$\delta\nu = \frac{1}{\Delta\tau} \text{ cm}^{-1} \quad (3)$$

the bandwidth of the interferogram is

$$\Delta f = \frac{\nu}{\delta\nu T} = \frac{N}{T} \text{ Hz} \quad (4)$$

where N is the number of spectrum resolution elements.

Required Measurement Time:

If the interferogram noise n_I in equation (1) is white detector noise it can be determined from the noise equivalent power of the detector by

$$n_I = \text{N.E.P.} (\Delta f)^{\frac{1}{2}} \text{ watts} \quad (5)$$

where the noise bandwidth is limited to that of the signal.

The dynamic range therefore becomes

$$I_0 / \text{N.E.P.} (\Delta f)^{\frac{1}{2}} .$$

By substituting into equation (1), the signal-to-noise ratio obtainable in measurement time T is given by

$$\frac{\bar{S}}{n_s} = \frac{I_0 \sqrt{T}}{\text{N.E.P.} N}$$

Multiple Scanning:

If the entire measurement time required for a satisfactory signal-to-noise ratio is allotted to a single interferogram, Δf is minimum, and maximum dynamic range is required. The measurement time may however be used to observe k interferograms each of duration T/k . For this situation Δf becomes kN/T and the dynamic range is reduced by \sqrt{k} . The data reduction procedure requires the averaging of k interferograms in order to obtain the required signal-to-noise ratio. Although the composite interferogram will have the original large dynamic range, it need only reside in a computer memory where dynamic range is readily available.

Sufficient bandwidth must be freely available for this procedure to be appropriate, since it does not pretend to use the bandwidth most efficiently. Thus, it only improves the performance of analog systems, since dynamic range and bandwidth are inseparable on digital channels.

Examples:

Multiple scanning can be used to reduce dynamic range where the limitation is imposed by analog telemetry or tape recording. These devices are typically limited to a dynamic range of about 100:1 and are capable of operating over large bandwidths.

As a typical case consider a Fourier spectrometer resolving 1000 spectral elements. Suppose that a signal-to-noise ratio of 100 is desired and that the data are to be recorded on an analog tape recorder with a dynamic range of 100. Suppose further that equation (6) indicates an observing time of 1000 seconds is required for the particular source and detector. Figure 1 indicates that a dynamic range of about 3000 is required and equation (4) indicates a bandwidth of 1 Hz. To properly record the signals, the observing time should be divided among $(3000/100)^2$ interferograms. The bandwidth is increased to 900 Hz.

Interferogram Averaging:

The averaging of interferograms is normally accomplished by sampling at a rate somewhat greater than $2f_{\max}$, and successively adding the values to a series of partial sums stored in a computer memory. The analog to digital converter must have a dynamic range of at least

$$\log_2 \left[I_0 / \text{N.E.P.} \cdot (kN/T)^{1/2} \right]$$

bits. Since k scans are to be added the computer word length must be at least

$$\log_2 \left[k^{1/2} I_0 / \text{N.E.P.} \cdot (N/T)^{1/2} \right]$$

bits, although only the

$$\log_2 \left[I_0 / N.E.P. (N/T)^{\frac{1}{2}} \right]$$

most significant bits need be retained.

SECTION IV
DIFFERENTIAL TECHNIQUES

Differential Interferograms:

The large dynamic range typical of interferograms results from the fact that I_0 is given by

$$I_0 = \int_{\Delta\nu} S(\nu) d\nu$$

where $S(\nu)$ is the spectral intensity of the observed source. I_0 can be greatly reduced by causing the interferometer to measure the difference between the observed source and a known one. This procedure is facilitated by the use of a dielectric beam splitter¹ in the interferometer. After a discussion of the theory, several examples of practical interest will be considered.

Complementary Outputs:

If the interferometer shown in figure 3 is lossless, the powers of the reflected and the transmitted outputs must sum to the original input power. Therefore, any modulation in, say, the transmitted light caused by scanning the

interferometer must be accompanied by a complementary modulation in the reflected light so that energy is conserved. Figure 3 illustrates this situation for a monochromatic input. For an arbitrary spectral input the interferograms may be expressed by

$$I_T(\tau) \sim \int_{\Delta\nu} S(\nu) \cos(2\pi\nu\tau) d\nu \quad (8-a)$$

$$I_R(\tau) \sim \int_{\Delta\nu} S(\nu) \cos(2\pi\nu\tau + \pi) d\nu \quad (8-b)$$

Dual Inputs:

The interferometer apertures which served above as outputs may each simultaneously act as an input to the interferometer. Suppose, for example, that the interferometer is illuminated by sources S_1 and S_2 located in opposite apertures. Since the interferometer is symmetrical each source produces both a reflected and a transmitted interferogram according to (8). The outputs each consist of composite interferograms according to

$$I_1 = I_{1T} + I_{2R} \quad (9-a)$$

$$I_2 = I_{2T} + I_{1R} \quad (9-b)$$

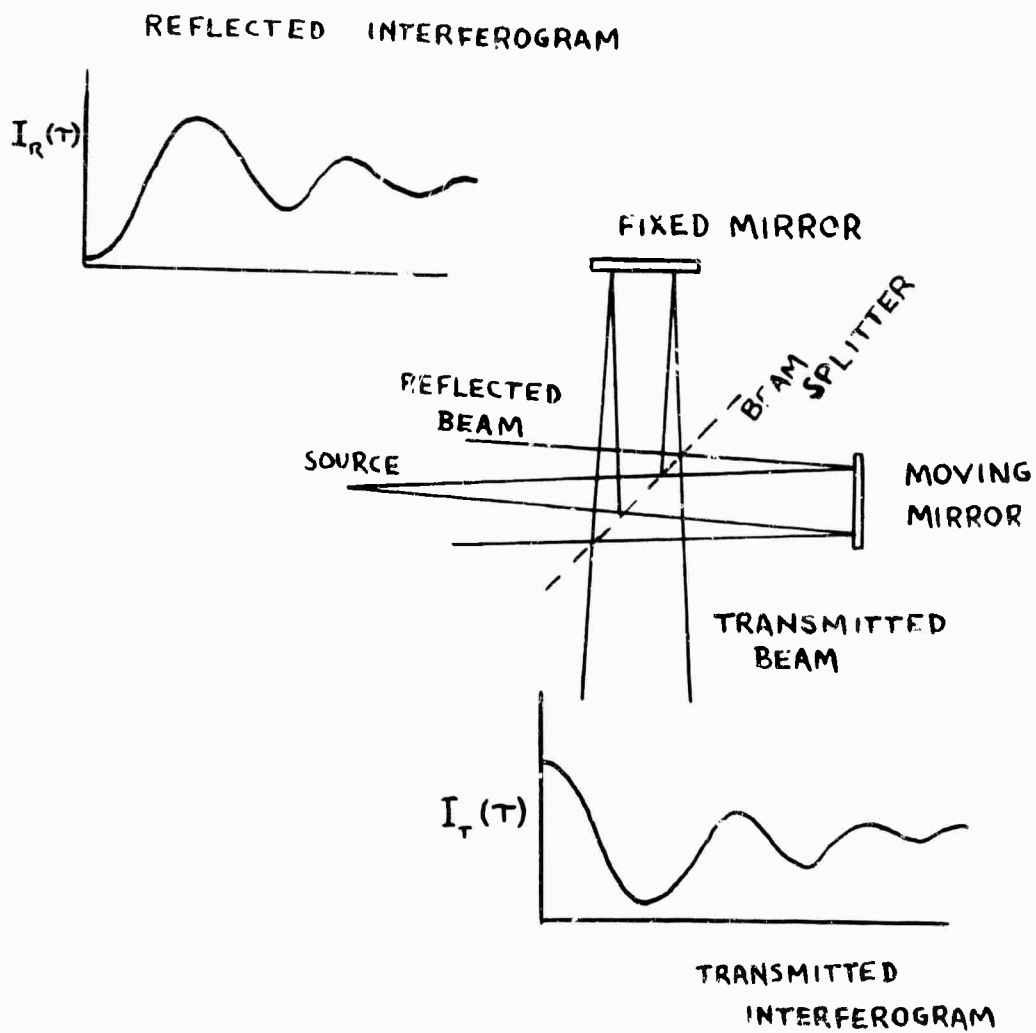

Fig. 3 Complementary outputs of lossless Michelson interferometer.

Due to the symmetry of the interferometer and since the form of (8) does not depend on S , we can write

$$\begin{aligned}
 I_1(\nu) &= \int_{\Delta\nu} S_1(\nu) \cos 2\pi\nu\tau \, d\nu + \int_{\Delta\nu} S_2(\nu) \cos(2\pi\nu\tau + \pi) \, d\nu \\
 &= \int_{\Delta\nu} [S_1(\nu) - S_2(\nu)] \cos 2\pi\nu\tau \, d\nu. \tag{10}
 \end{aligned}$$

The second output I_2 is $-I_1$.

From (10) we see that the dynamic range of an interferogram can be arbitrarily reduced by placing an appropriate known source S_2 in the vicinity of the detector. This source should resemble as closely as possible the observed source S_1 . Our experiment would therefore consist of measuring the difference between S_1 and our best guess of S_1 . The dynamic range requirements are reduced according to our a priori information.

The use of equation (1) for this situation is conditional. If $(S_1 - S_2) \geq 0$ or if $(S_1 - S_2) \leq 0$ for the entire spectrum, equation (1) is applicable and \bar{S}/m_s indicates the mean signal-to-noise ratio in the difference spectrum and I_0 relates to equation (10). The final spectrum S_1 is obtained by adding (or subtracting) S_2 to the measured difference spectrum.

Equation (1) may in practice be applied whenever the difference spectrum is predominantly of one sign. When this is not the case, I_c need not be the largest portion of the interferogram and the peak signal-to-noise ratio becomes a function of the form of S_1 and S_2 and is therefore difficult to predict. The data reduction for this situation is complicated by the fact that a phase sensitive Fourier transformation is required to distinguish the negative and positive regions in the difference spectrum.

Natural Differential Interferograms:

In the thermal region of the infrared the detector and its environment provide a second input. It consists of thermal radiation and is present whenever cooling of the instrument is not performed to suppress it. The instrument radiance should approximate that of the source to significantly reduce dynamic range. For convenience where two sided interferograms are employed, phase sensitive Fourier transformation can be avoided by insuring that the instrument spectral radiance is always somewhat greater than that of the source.

The use of this method need not be limited to the thermal region. In spectral regions where natural thermal radiation does not suffice, the second input can consist of a hot source placed in the neighborhood of the detector.

SECTION V
SIGNAL COMPRESSION

Logarithmic Amplification:

The most plebian approach to dynamic range problems is logarithmic signal compression. The fact that interferograms involve both positive and negative signals inflicts only minor variations of the procedure. For example, the cube (or fifth, etc.) root of the signal can be employed in place of the logarithm. The plot of these curves in figure 4 shows that the desired compression of large signals is retained, but with a positive-negative facility.

Two basic problems of differing severity are encountered. The first is that the requisite bandwidth for faithful reproduction is substantially increased unless the implementation is carried out with extraordinary care. The effect corresponds to the extra harmonics generated by non-linear distortion in high fidelity (music) systems. Thus, if the compression is done blithely with analog circuitry the original sample frequency will be inadequate. More exotic techniques such as digital manipulation after sampling are required to avoid the problem.

The second, and ultimately more severe, problem is that the errors become concentrated in regions of high signal of the interferogram. It is just those regions which provide

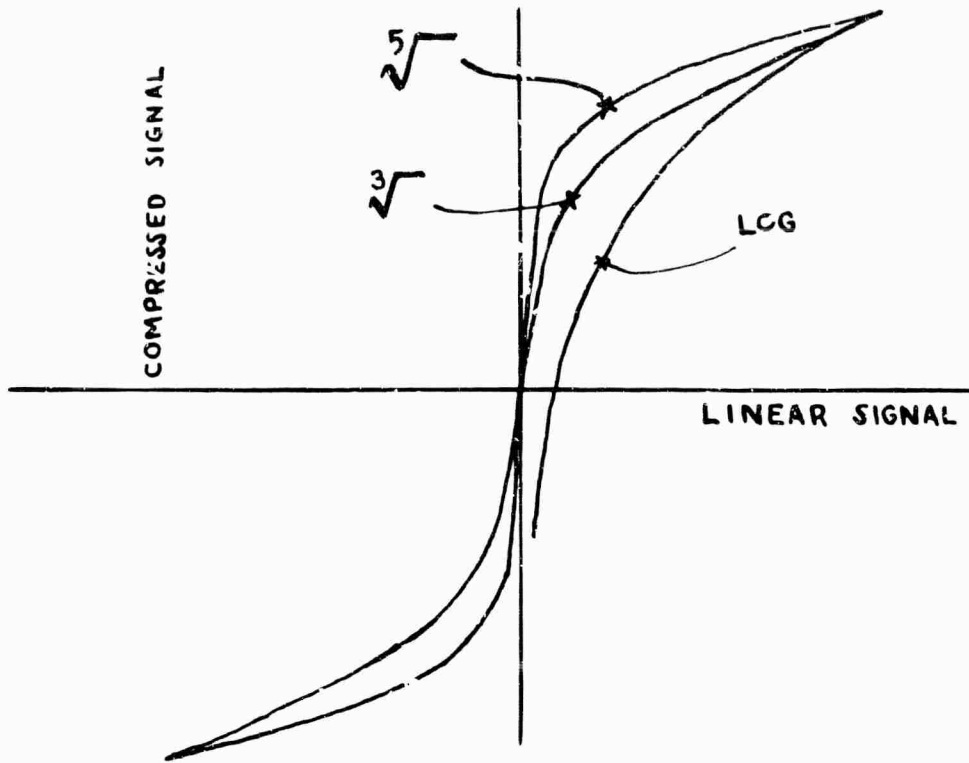

Fig. 4 Analytic signal compression.

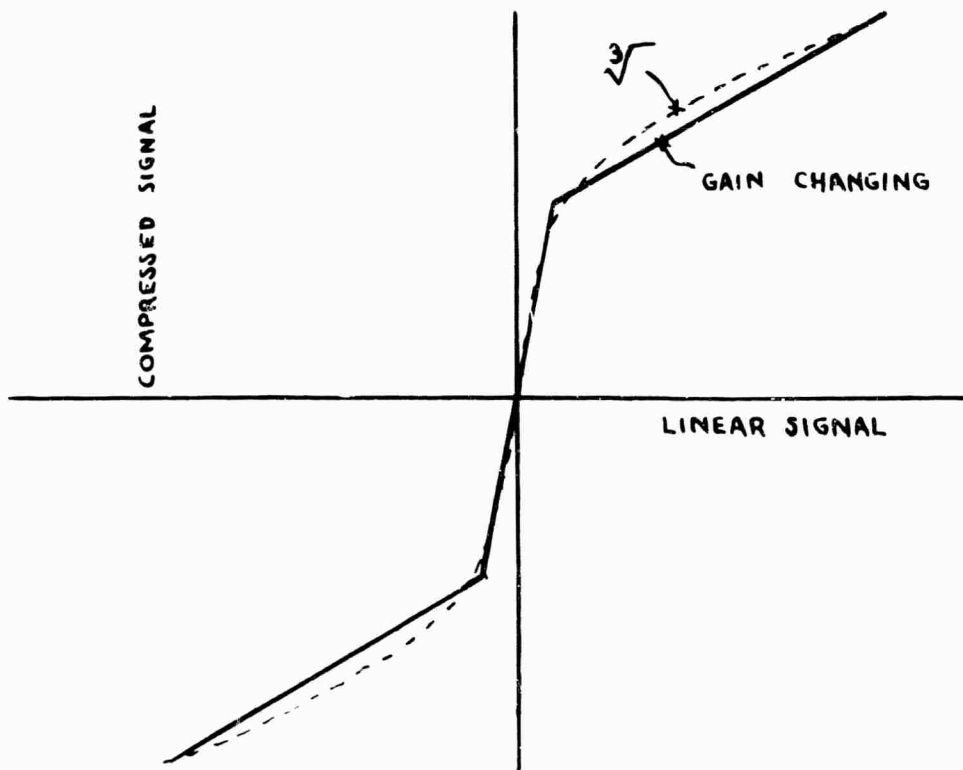

Fig. 5 Linear segmented signal compression.

the most definitive character to the final spectrum. The space frequency distribution of the noise in the final spectrum is no longer white, but closely corresponds to the space frequency distribution of the spectrum. The presence of such non-uniform noise can be very deceptive for the scientific interpretation of the spectrum. Typical characteristics of this sort will be evident in the subsequent section describing experimental (computer simulated) results.

A plausible criterion for the effectiveness of compression (or other) procedures may be found in the resultant distribution function of the interferogram. One should strive to utilize each level of the transmission channel with equal probability. In this manner each word conveys a maximum of information.

From this point of view, the problem with the initial interferogram is that it tends to have large central fringes but then spends most of its time fluctuating near zero level. The higher levels of the transmission channel tend to be wasted except for the brief occurrence of the central fringes.

Gain Changing:

Gain changing procedures, such as advocated by Forman³ whereby the gain is decreased when the signal exceeds a prescribed level, are simply particular cases of compression. In this case we obtain a characteristic as shown in figure 5

along with the cubic curve. It amounts to a sectional approximation of the smooth procedure, and engenders the same problems. Forman's results clearly show the non-white character of the noise on resultant spectra, although he does not mention the effect.

In evaluating this procedure it must be kept perfectly clear that one bit of information is required to establish which gain pertains. In other words, the span must be the total vertical span of the linear sections and not just the span of any individual section.

Often, one can avoid this "extra" bit with a modest amount of a priori information concerning the spectrum. Since large amplitudes occur only in the central portion of most interferograms it is possible to prescribe the lower gain over a prespecified central portion of the interferogram. The a priori information serves to ascertain just how wide a portion. In addition to eliminating the extra bit, this procedure at least gives consistently non-white noise characteristics which are signal independent.

We have also considered digital data transmission systems involving variable word lengths. This concept led to such extensive buffering problems however, that we abandoned it.

Experimental Simulations:

A series of computer simulations was carried out in order to clearly see the effects of dynamic range problems. The spectrum shown in figure 6 was adopted and its cosine Fourier transform also shown in figure 6 represents the interferogram. Next, a controlled amount of random noise was added to the interferogram, and the result retransformed into the spectral domain.

The effects of 60, 50, 40, and 30 dB (voltage) channels ($S_{\max}/n_s = 1000, 316, 100, 32$, respectively) for interferogram transmission were thus simulated. The interferogram from the 60 dB channel shown in figure 7 appears to the eye as a faithful rendition of the original. The resulting spectrum shown in figure 7 is conspicuously degraded however. That comparison serves to illustrate the severity of the dynamic range problem. Subsequent figures for the 50, 40, and 30 dB channels show that when noise becomes conspicuous on the interferogram, the spectrum becomes barely recognizable.

Turning to the compression procedures, figure 11 shows the cube root compressed interferogram. The faint trace is the original interferogram superimposed. Noise simulating a 40 dB channel was added to the compressed interferogram, the interferogram expanded and the spectrum shown in figure 11 resulted. On the face of it, this spectrum seems comparable

Interferogram No Noise

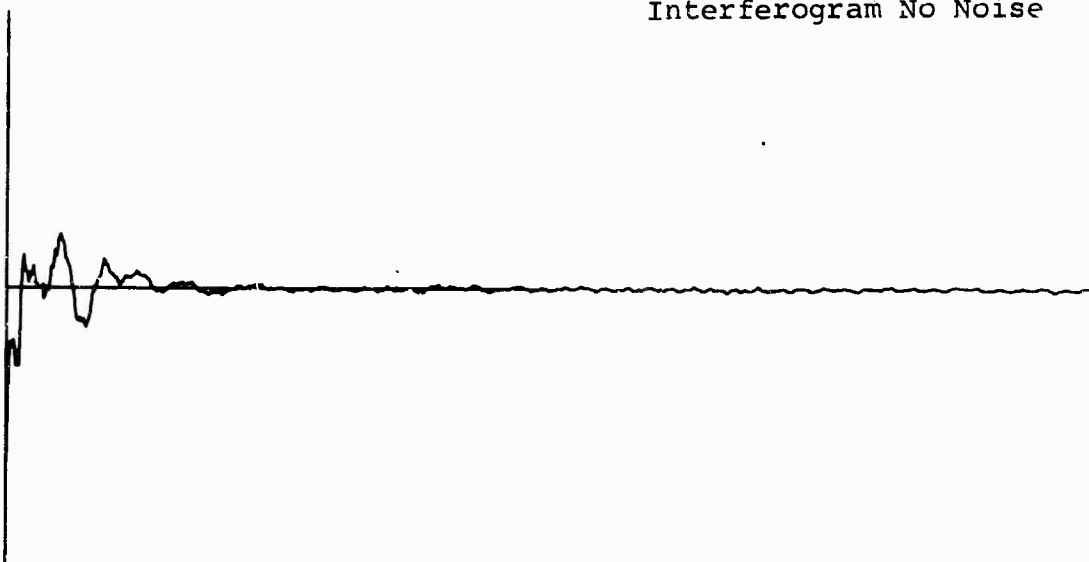

Spectrum No Noise



Fig. 6 Interferogram, Spectrum
adopted for simulations.

60 dB Interferogram



Spectrum 60 dB Single Channel

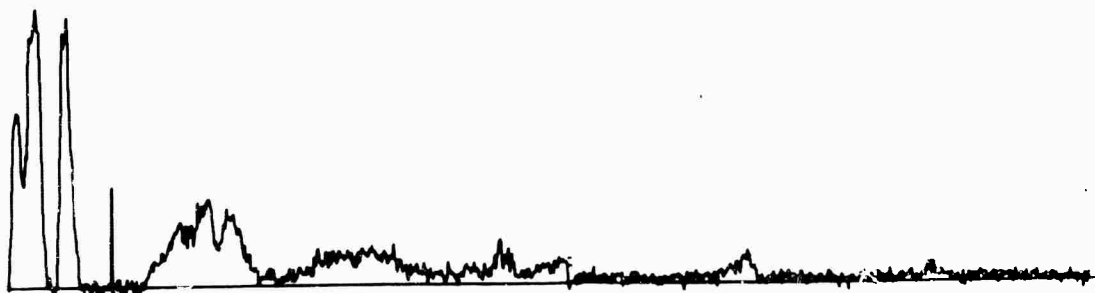
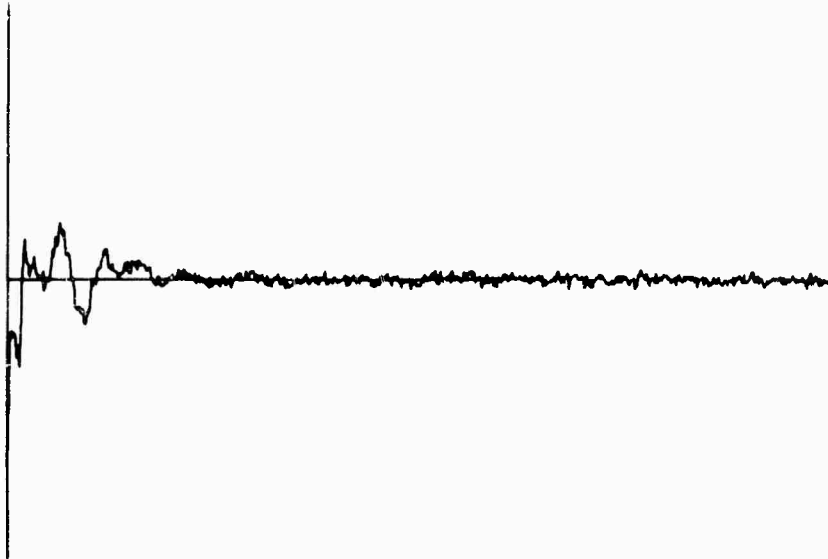

Fig. 7 Interferogram, Spectrum
employing 60 dB channel.

50 dB Interferogram



Spectrum 50 dB Single Channel



Fig. 8 Interferogram, Spectrum
employing 50 dB channel.

40 dB Interferogram

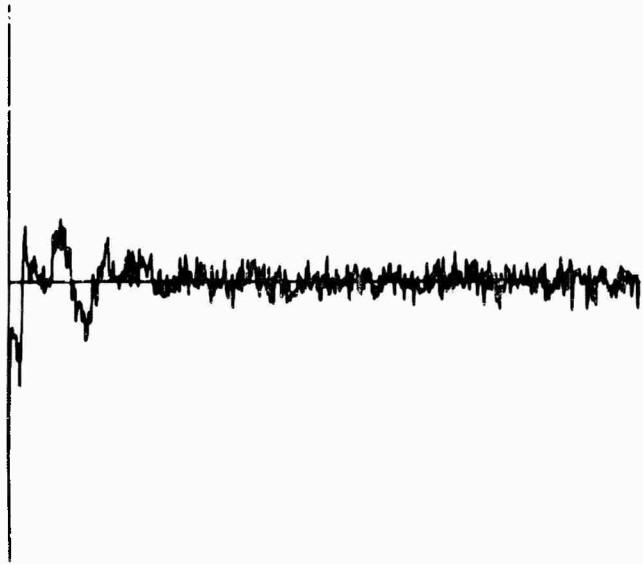

Spectrum 40 dB Single Channel

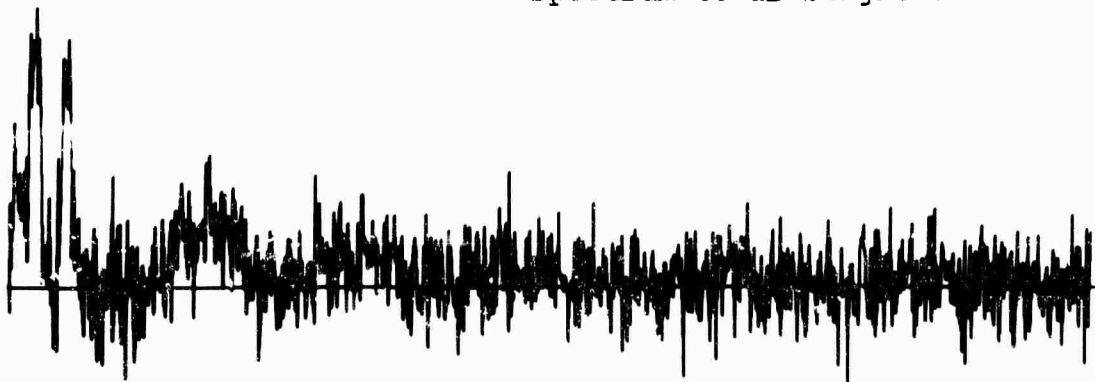
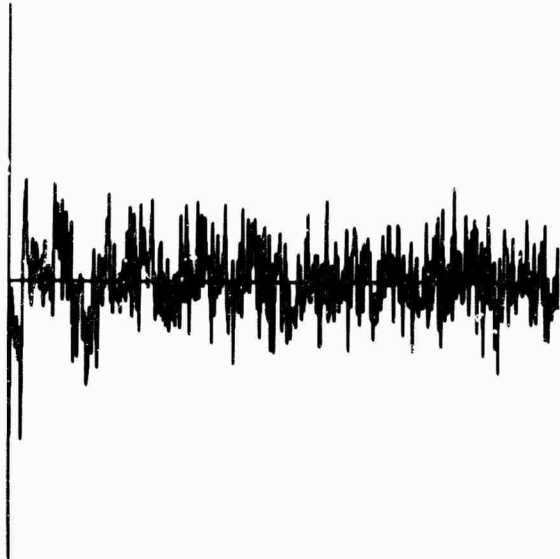

Fig. 9 Interferogram, Spectrum
employing 40 dB channel.

30 dB Interferogram



Spectrum 30 dB Single Channel

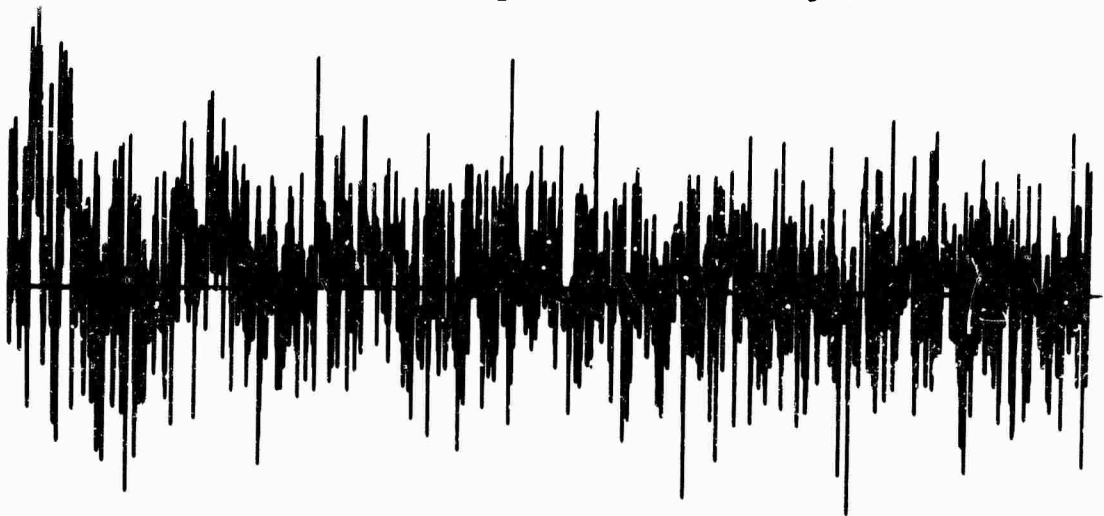
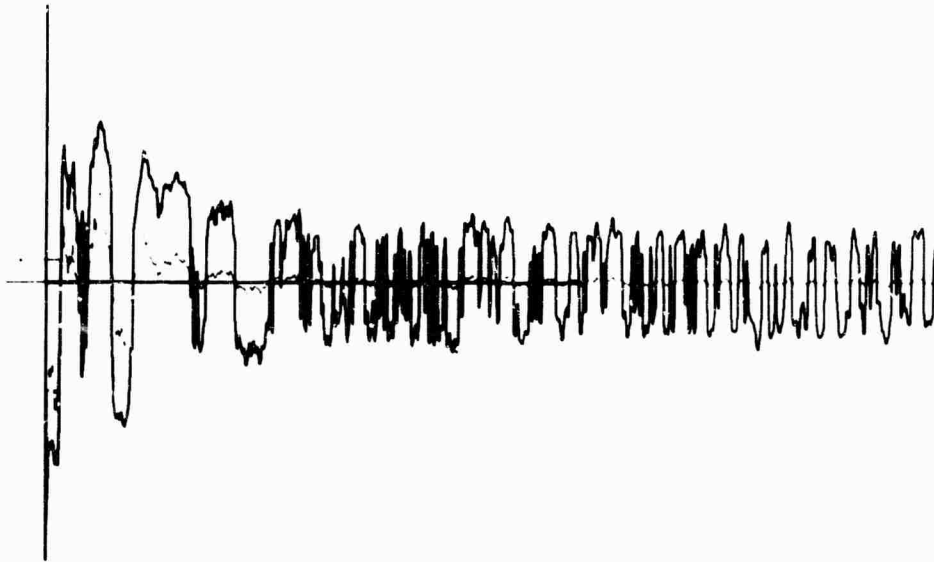

Fig. 10 Interferogram, Spectrum
employing 30 dB channel.



Spectrum 40 dB Channel
Cubically Compressed

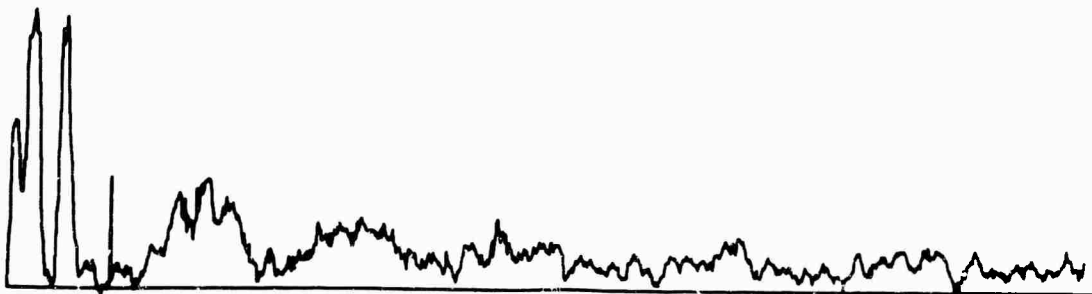

Fig. 11 Interferogram, Spectrum
employing cube root channel.

to a 55 dB channel without compression, and so we estimate a 15 dB decrease in dynamic range requirements.

That conclusion is very deceptive. Note in particular the wandering zero level. This would not be at all apparent without the noiseless spectrum for comparison. The wandering level is due to the non-white character of the noise, and reflects the supplementary low space frequency noise.

Already in the interferogram an incipient fault of the procedure is becoming evident. This fault is that the signal is displaying a marked avoidance of zero level. The effect would be even more pronounced for fifth root compression. The consequence of the effect is that the transmission channel is still used inefficiently. The signal distribution function greatly upsets uniform probability of the available channel levels.

The simulation of a sectional gain change is shown in figure 12. The gain of the outer fringes was increased by a factor of 32 (30 dB), then the noise corresponding to a 30 dB channel added. The interferogram shown in figure 12 was reconstructed from the result. This looks like a 30 dB channel for the central fringes and the equivalent of a 60 dB channel for the outer fringes. The compressed interferogram could have been genuinely transmitted on a 30 dB channel.

2 Channel Interferogram Gain
Ratio 32 30 dB Channel

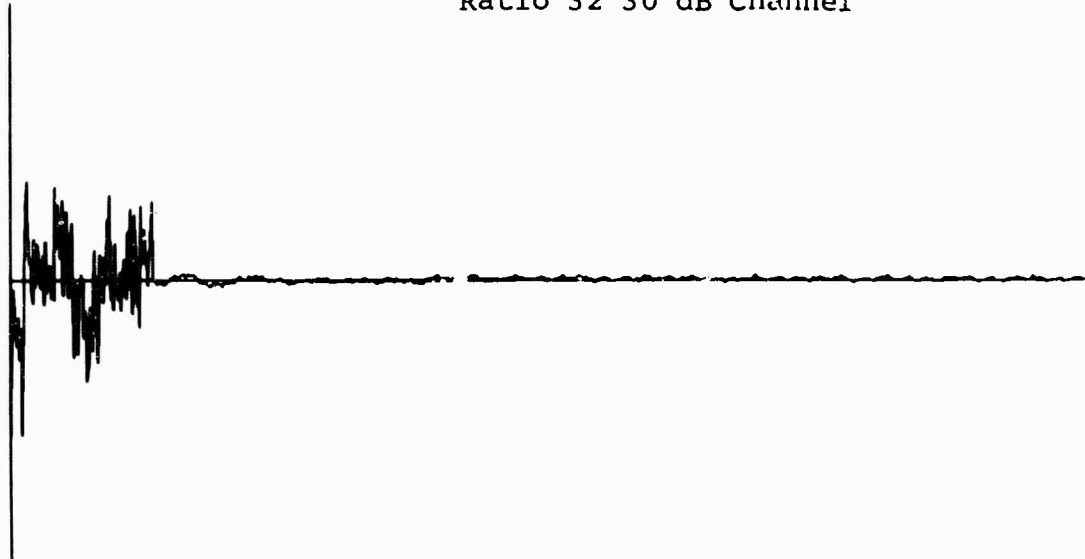

Spectrum 2 30 dB Channels
8 to 1 Gain Ratio



Fig. 12 Interferogram, Spectrum
employing sectional gain change.

Again, the noise seems to correspond to a 15 or even 20 dB improvement, but also again, the wandering zero level, or low space frequency noise is evident.

SECTION VI
CHIRPING TECHNIQUES

Chirping:

Horizontal expansion of the central fringes offers an alternative to the vertical compression techniques. Horizontal expansion comes from making the position of the central fringes frequency dependent. The resultant fringes resemble Chirp interferogram is not inappropriate.

Although the immediate present objective of this study of the chirp procedure is the reduction of dynamic range, a more far reaching consequence is the additional insight it provides concerning the nature of interferograms.

Shape of the Central Fringes:

A sinusoidal form is usually adopted to describe the fringes of a Michelson interferometer. Thus, the fringes are symmetric about zero path difference and the fringes from all wavelengths are all in phase, constructively interfering to provide a large amplitude fringe. Phase shifts upset this description with varying degrees of severity. A few simple examples are in order.

First, the introduction of a phase shift independent of frequency destroys the symmetry of the interferogram, while retaining the envelope of the interferogram. For example, a 90° phase shift converts perfect symmetry to perfect

antisymmetry. It is important to realize that any angle may be invoked so that the resultant interferogram will generally be non-symmetric. Even in this situation all fringe frequencies have the same phase at the center, and therefore add constructively. It is very important to be aware of the existence of such a non-symmetric but unchirped interferogram. In normal Fourier spectrometry this is a frequent experimental occurrence and should not be disconcerting.

For a second example, the introduction of a phase shift which is proportional to fringe frequency serves only to displace the entire interferogram. The form of the central fringes remains unaltered, and the simple shift of our frame of reference restores the original symmetry.

Any more complicated dependence of phase on fringe frequency can be thought of in terms of linear segments. Each linear segment would require a different shift in the frame of reference according to the slope of that segment. In this fashion the central fringe position may be distributed as a function of fringe frequency over a large retardation. The total "power" in the interferogram remains unaltered and so the maximum fringe amplitude diminishes. Roughly speaking if we quadruple the half width of the central fringes, the peak amplitude is halved (square root relationship).

The notion of stationary phase, rather than zero path difference, now serves to specify the central fringes. As long as the phase is a smooth function of fringe frequency then an appropriate shift of the reference frame can null the gradient at any one frequency. For this shifted position the phase is independent of frequency for a small interval, and the center of the reference frame suffices to define the central fringe position for that frequency interval.

Any more detailed analysis would quickly reveal that this description of fringes amounts to group velocity propagation. The phase shifts are most easily introduced by the insertion of refractive material into one beam of the interferometer. The phase shifts result from dispersion in the index of refraction (phase velocity) of the material. The position shifts of the central fringes can be described in terms of group velocity index of refraction of the material.

The actual details are not particularly relevant in this report. Suffice it to say that two different materials, one in each beam, must be used if interferometer throughput is to be maintained. Detailed formulae for the appropriate thickness may be found in reference 1.

Experimental Simulation:

The same test spectrum served for a computer simulation of chirping. For a small touch of realism, the spectrum was

considered to range from about 4.5 to 0.8 micron, with the dispersive effects of 5 mm of IRTRAN-5 (MgO) providing the chirping. Figure 13 shows the chirped and unchirped interferogram. The central fringe position in this case is not a monotonic function of frequency but bends back. Thus, low frequencies are on the right, intermediate at the left, and the high frequencies return a little toward the right.

The reduction of dynamic range, found from the ratio of the maxima in the chirped and unchirped interferograms is about 13 dB. The spectrum calculated from the chirped interferogram is shown in figure 13. In this case, the amplitude and phase Fourier transform served in place of the previously employed cosine transforms. There was clearly some malfunctioning of the program or plotter, but the results looked sufficiently encouraging to do some real experiments.

In order to appreciate the remaining experimental results, a discussion of the possible data reduction procedures is essential

On The Reduction of Extremely Chirped Interferograms:

An extremely chirped interferogram is one in which the distribution of central fringe positions as a function of color spans almost almost the entire length of the interferogram. It is even permitted to fold back so that both short and long

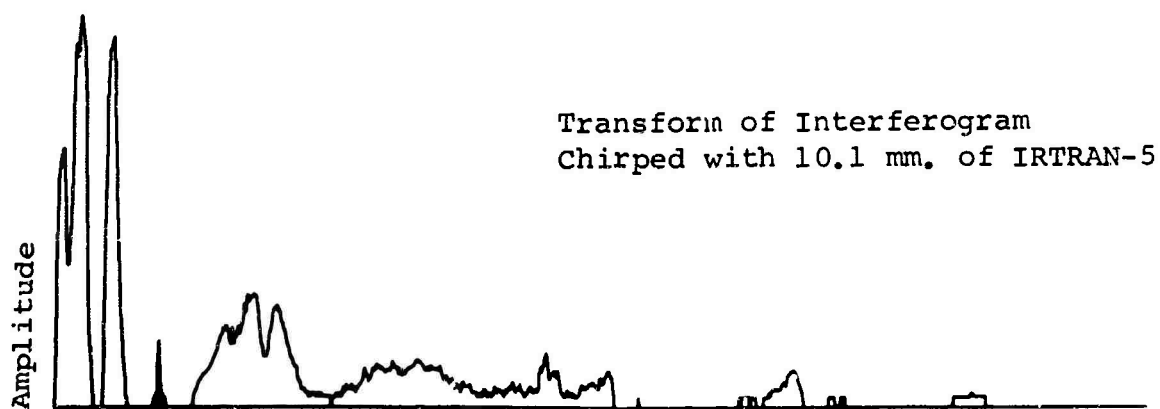
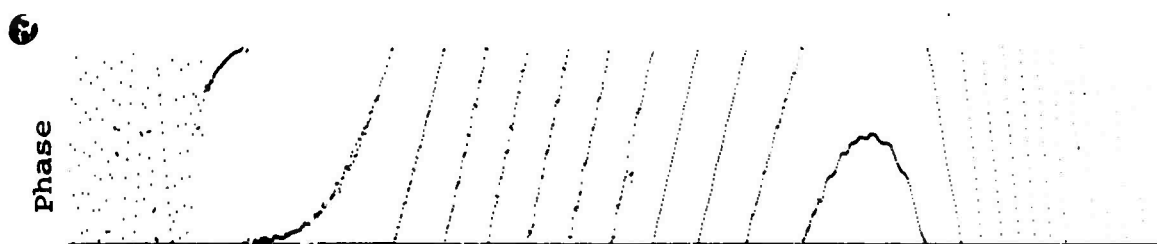
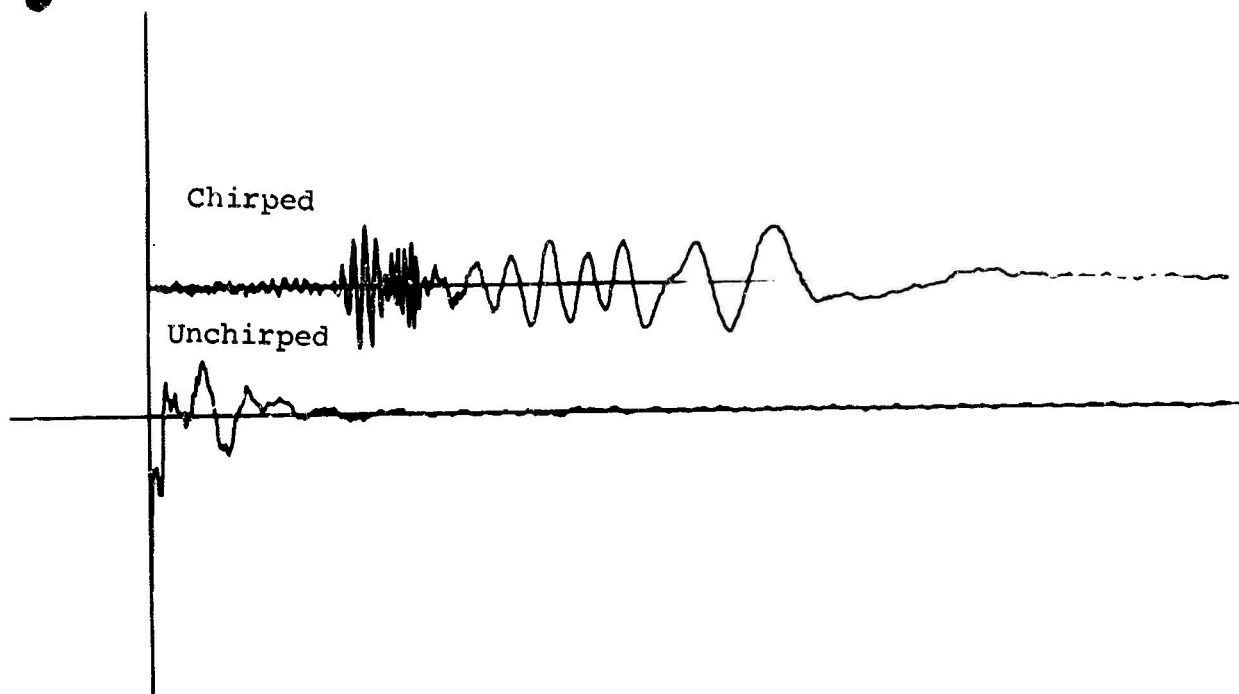

Fig. 13 Interferogram, Spectrum employing chirping.

wavelengths have their central fringes near one end of the interferogram while the middle wavelengths have their central fringes near the other end. We will subsequently see that if the chirping is restricted to the central two thirds of the interferogram the analysis remains convenient. It will be shown in the appendix that extreme chirping is still sufficiently mild to satisfy the conditions of the general relation^{1/}. Thus, as long as a phase curve is available (this must be obtained as the phase spectrum of a smooth black body spectrum), phase correction is legitimate.

The clumsy aspect of straightforward phase-corrected Fourier analysis is that the instrumental profile is misleading for those spectral regions whose central fringes lie away from the center of the interferogram. The clumsiness is actually more apparant via the spectral transfer function^{4/} (the cosine Fourier transform of the instrument profile). According to the general relation the spectral transfer function is just the symmetric part of the truncation function about the central fringe.

Figure 14 serves as a guide to figures 15 through 18, and shows the location of the central fringes (vertical slash) with respect to the interferogram range (boxcar) for a through i. Figure 15 shows the spectral transfer functions applicable to straightforward calculation (phase-corrected Fourier transformation) for the range of central fringe locations

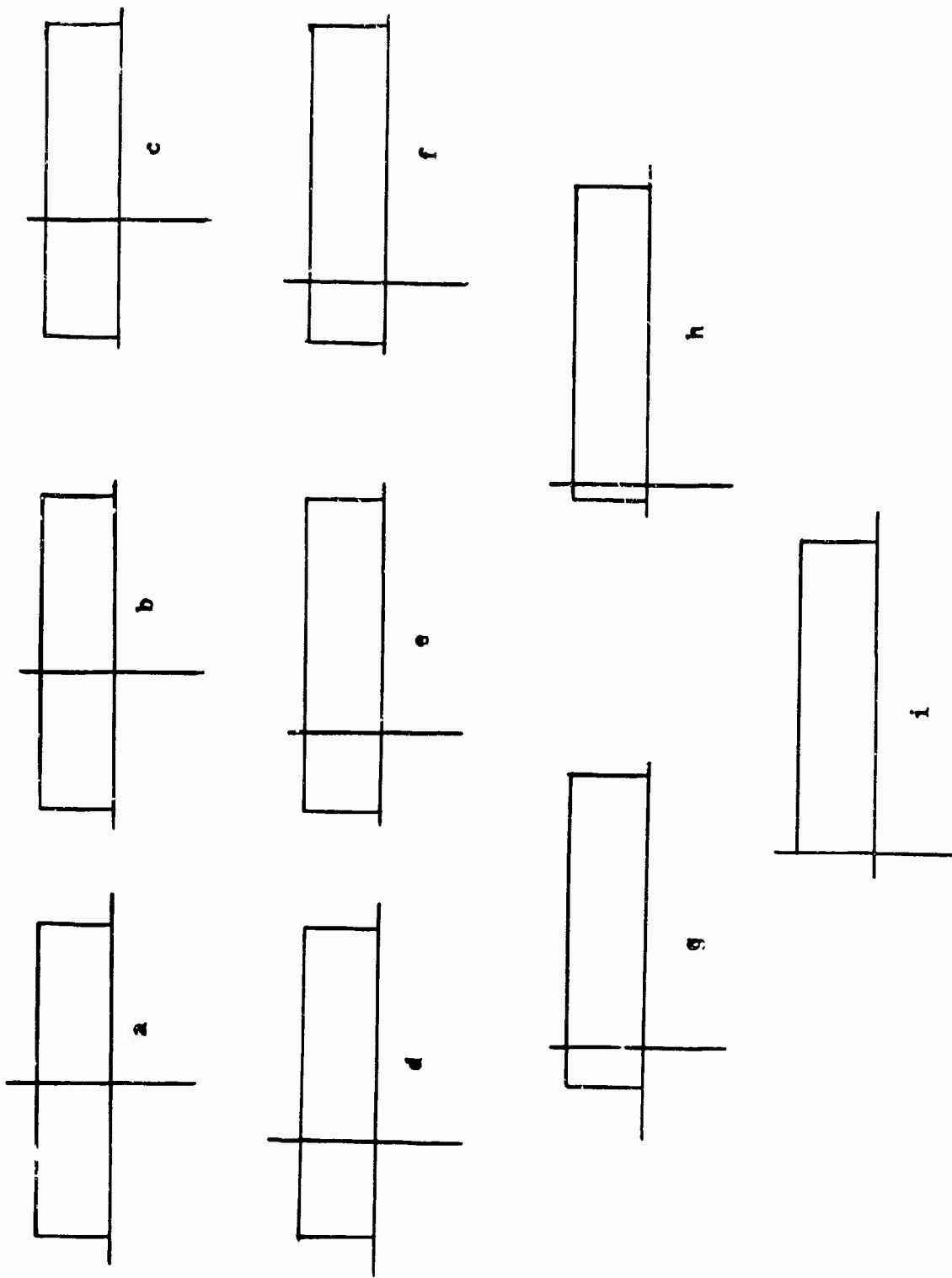

Fig. 14 Central fringe position relative to truncation boxcar for various offsets.

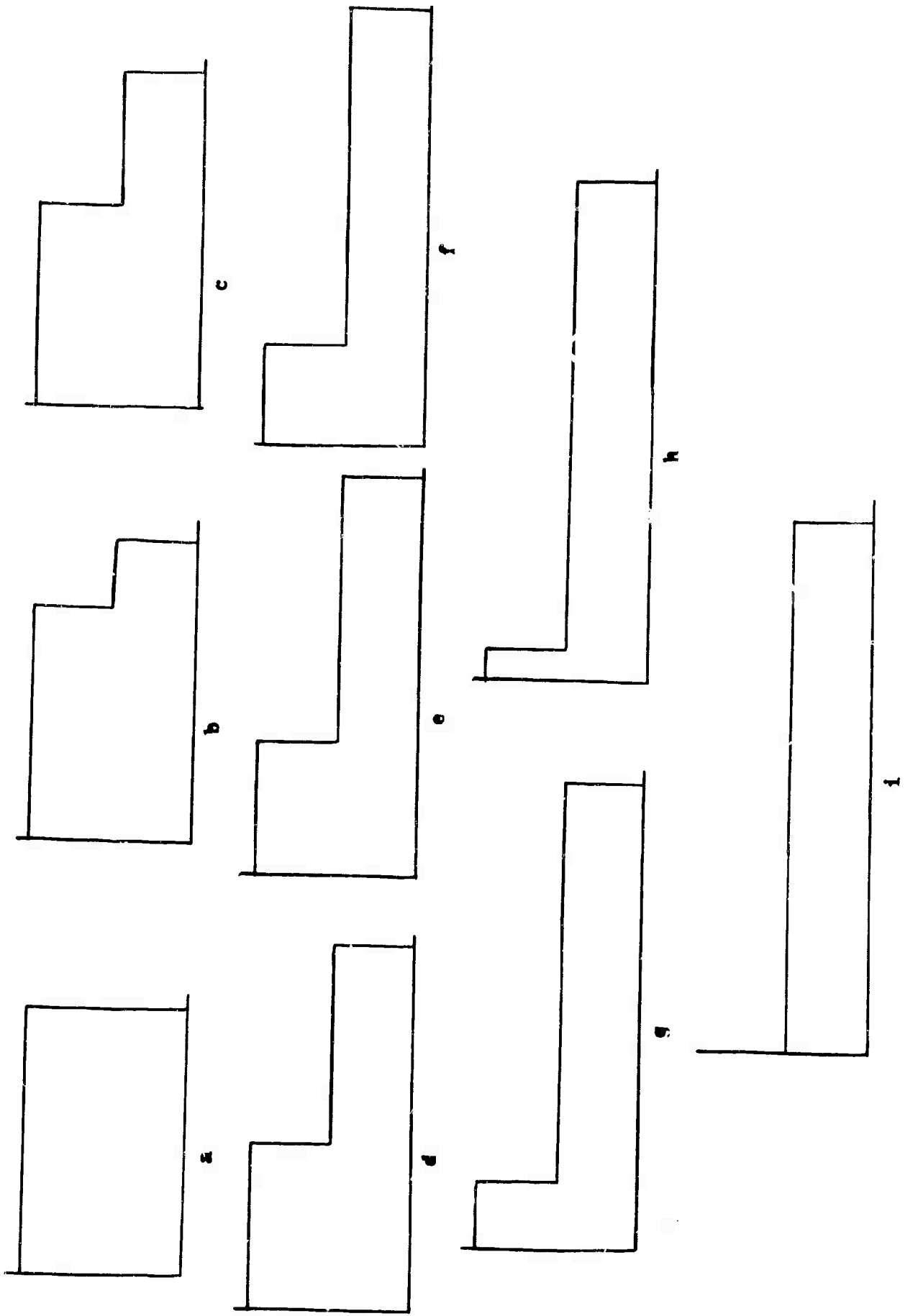

Fig. 15 Spectral transfer functions for various effects with no apodization.

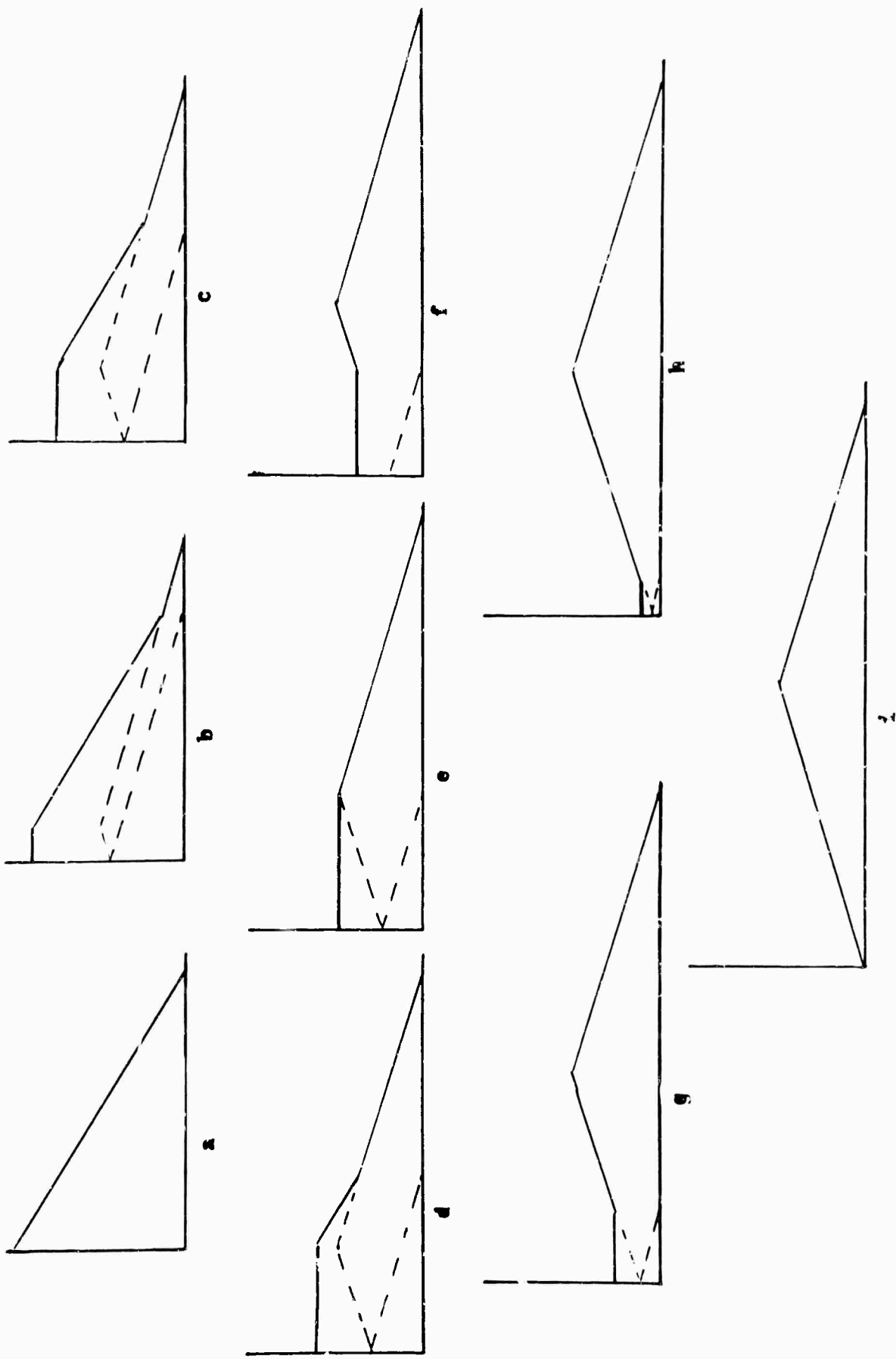

Fig. 16 Spectral transfer functions for various offsets with triangular apodization.

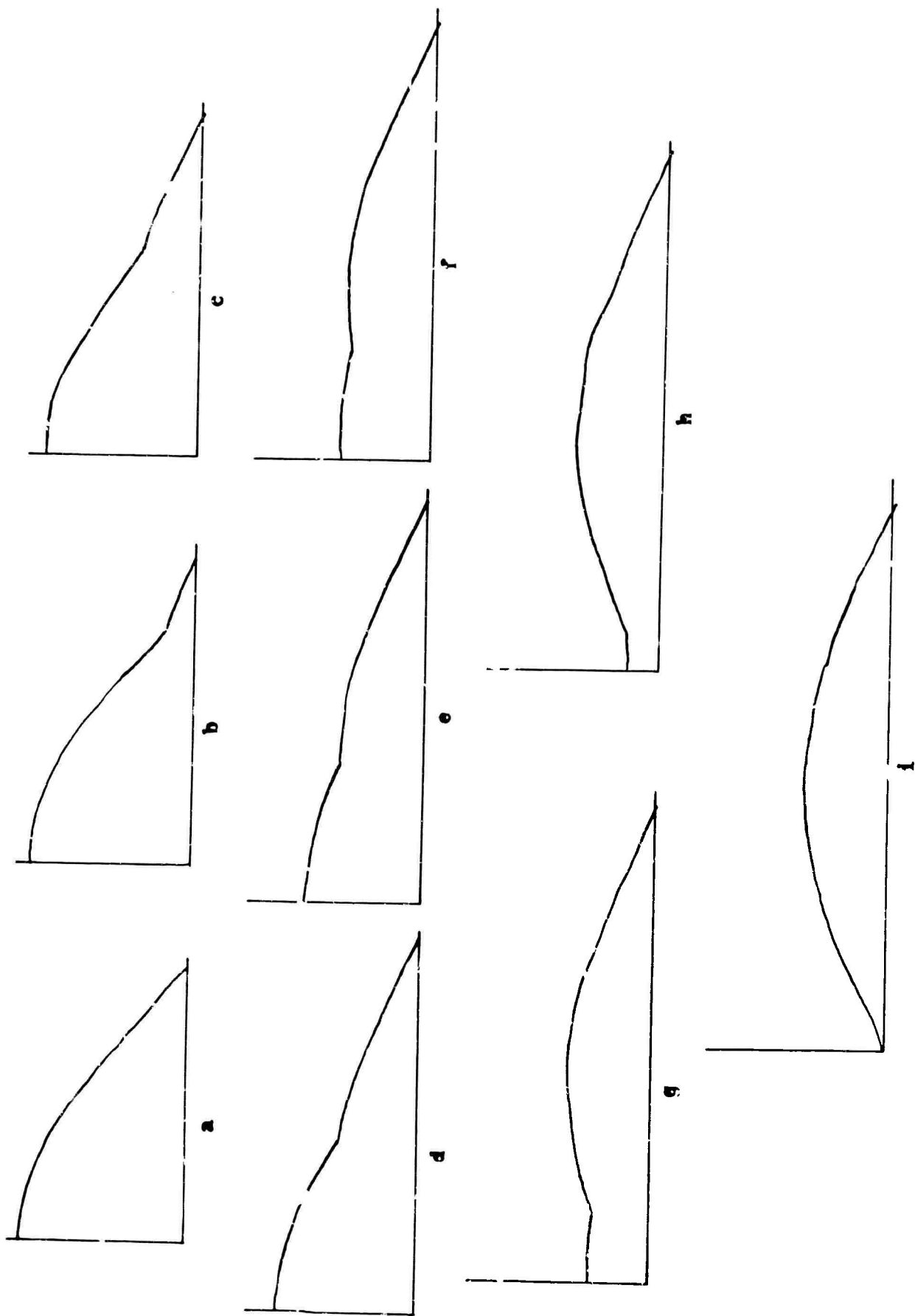

Fig. 17 Spectral transfer functions for various offsets with half cosine wave apodization.

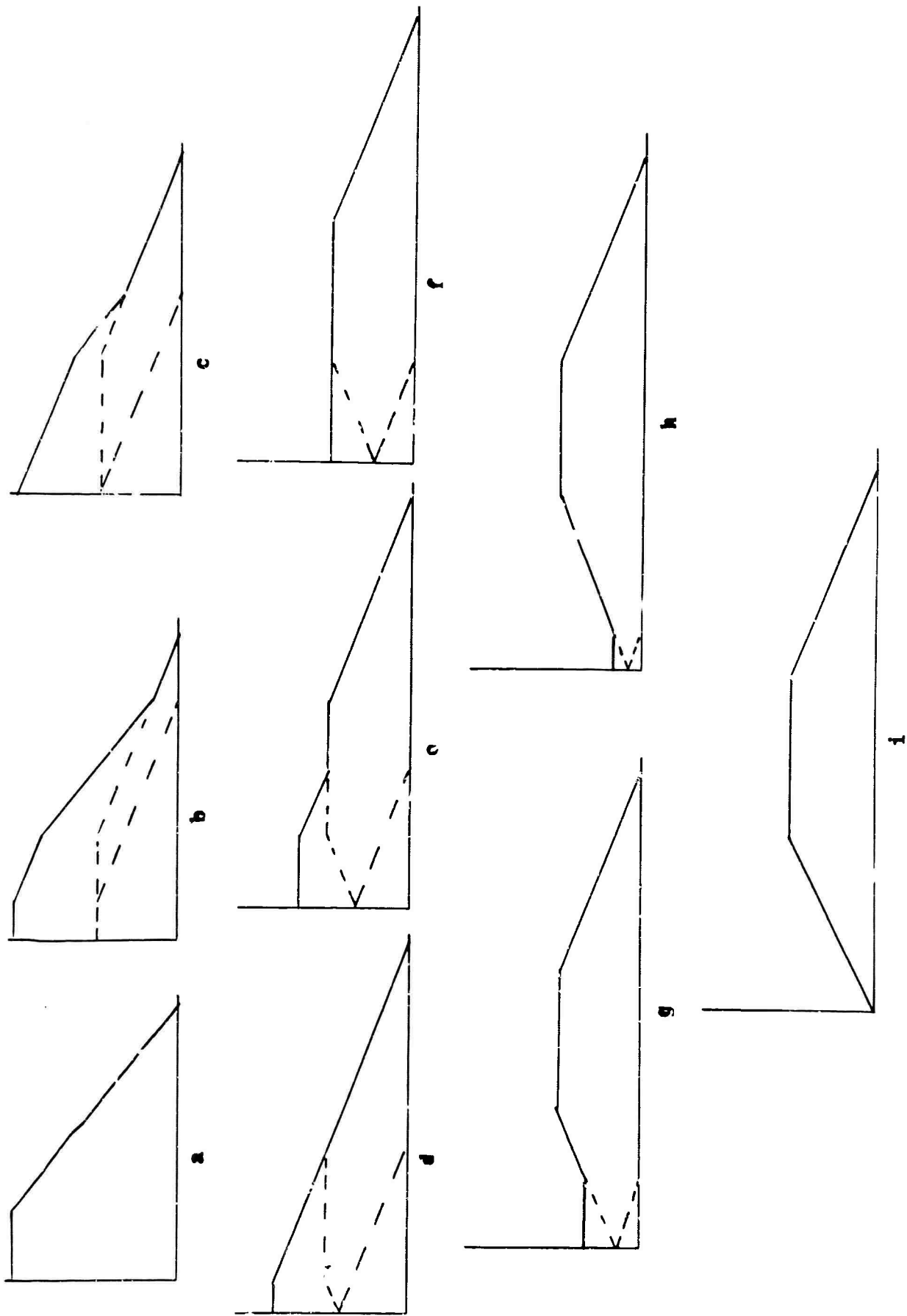

Fig. 18 Spectral transfer functions for various offsets with trapezoidal apodization.

a through i . When the central fringes are not centrally located in the truncating function, and ungainly steps occur in the spectral transfer function. A step discontinuity leads to sidelobes on the instrument profile, which decay as $1/\Delta f$, whereas a slope discontinuity leads to a decay rate of $1/\Delta f^2$. When the step appears as in figure 15 f the contrast of unresolved absorption lines is diminished by about 1.6 from that which one would anticipate based on instrumental resolution.

It would be possible to resort to two dimensional apodization (apodization as a function of wavelength as well as retardation), but this precludes the use of the efficient Cooley-Tukey transform program 5,6/. Much less drastic measures are definitely called for, and will be perfectly suitable.

If triangular apodization is applied to the interferogram, the resulting set of spectral transfer functions is shown in figure 16. These functions, at least a through f, are obviously superior to those of figure 15. The only defect is easily removed by equalizing the spectrum. A given wavelength has its central fringes a certain amount off-center (as determined from the black body reference phase spectrum) and so must be multiplied by a factor to normalize that spectral transfer function. The apodization remedies the contrast; the equalization restores the instrumental wavelength response. Two other initial apodizations are shown in figures 17 and 18.

The first is a half cosine wave, the second a trapezoid, appearing as in 17 and 18 respectively. Clearly these apodizations are suitable out to offsets between f and g. Thus, if the chirping is restricted to roughly the central two thirds of the interferogram, this apodization-equalization procedure is very suitable. For larger offsets, the hump appearing in the spectral transfer function will become unacceptable, and the last offset i (to the edge) is impossible to equalize.

Offset in the range g to h can be made available by using a second pass of the Cooley-Tukey program using a different initial apodization and then linearly combining the two spectra with weighing factors dependent on wavelength. cursory investigation of this two (or more) pass composite procedure indicates that the rewards are probably not worth the trouble.

We may now recapitulate the recommended computing procedure. A reference interferogram is obtained of a continuum source such as a black body. This interferogram should then be triangularly apodized (apodization is desirable but not essential) and the amplitude and phase spectra computed. These will appear as in figure 18A, phase always being referred to the central sample. With the understanding that the phase spectrum is modulo 2π , the step discontinuities are removed by adding integral multiples of 2π (actual computation will probably be in cycles rather than radian; 1 cycle = 2π radians).

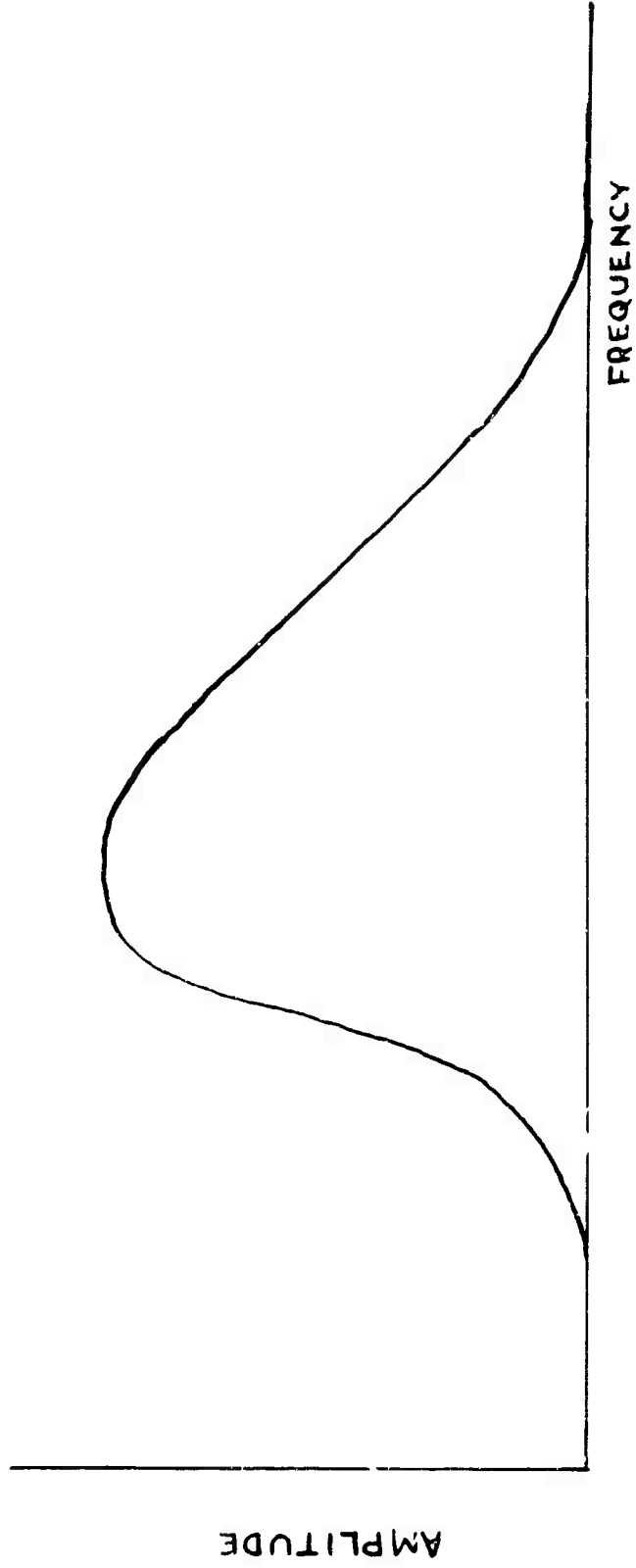
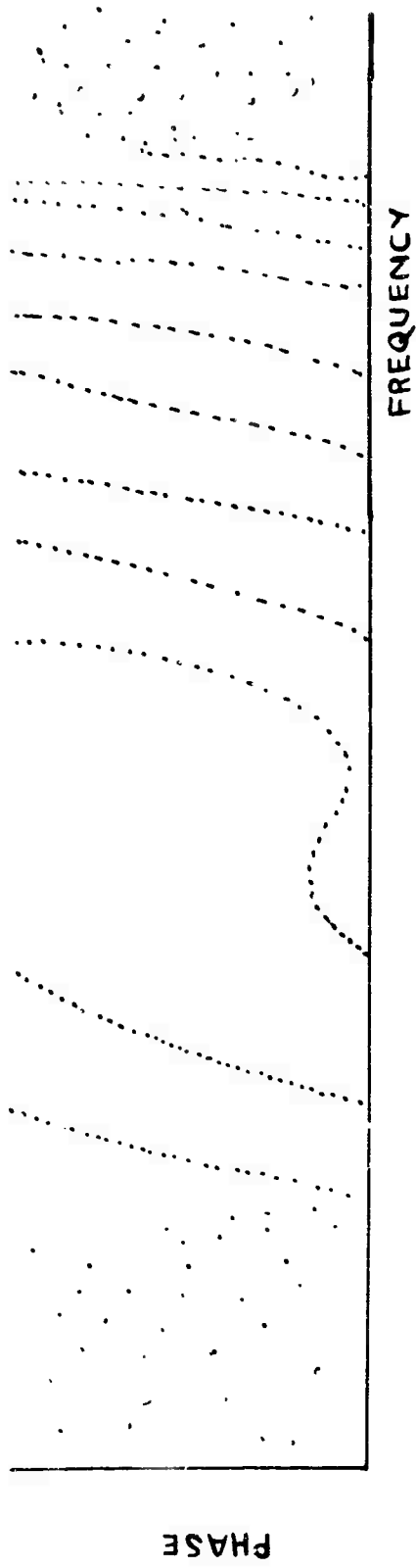

Fig. 18A Display format of phase and amplitude spectra.

A least squares polynomial is then fit to the phase spectrum. This polynomial is then differentiated. This derivative is a measure of the offset of the central fringes versus frequency. Its scale factor is one cycle per sample frequency per sample point.

The unknown interferogram is next apodized (triangular, cosine or trapezoid) and Fourier transformed. From its phase spectrum, we subtract the curve fit of the reference phases. The result should be an approximately straight line, almost horizontal and almost intercepting zero. If it is not accurately horizontal and/or does not intercept zero, it should be modified to do so by adding a constant and a gradient. Phase correction is now carried out by multiplying the amplitude spectrum by multiplying the amplitude spectrum by the cosine of the modified phase spectrum.

Equalization is next in line. The reciprocal of the equalization factor is simply the apodization factor at the offset determined two paragraphs ago. If any appreciable modification was applied to the phase spectrum by adding a linear term, the corresponding offset modification (a constant) should precede ascertaining the apodization ($1/\text{equalization}$) factor. The phase corrected spectrum is multiplied by the equalization factor.

This final spectrum is that of the source, with spectral transfer functions as indicated by the figures. In other words,

the instrument profile changes somewhat over the spectrum to correspond to the spectral transfer function at the offset corresponding to each spectral frequency.

Experimental Results:

The real experiments involved an interferometer chirped with 5 mm of IRTRAN-5 vs. 9 mm of CaF_2 in the other beam. The source was an acetylene flame, and the wavelength range was mostly between 2 and 2.5 microns. Half sample frequency, the rightmost point on the spectral traces, was at 5870 cm^{-1} .

The position of the central fringes as a function of wavelength is shown in Figure 19. This position was determined experimentally as the slope of a black body phase spectrum. The factor which relates position to slope is one sample point for each cycle per sample frequency.

For this extreme degree of chirping, the questions of validity of data reduction procedures are paramount. A chirped acetylene interferogram is shown in figure 19A. The amplitude and phase spectra of a similar interferogram is shown in figure 20. It is interesting to note the resemblance of the envelope of the interferogram to the amplitude spectrum. While this similarity is not accidental, it is of little use as a spectrum. For example, monochromatic light still presents uniform fringes over the entire interferogram.

Several procedures were used in the data reduction. Simple amplitude and phase spectra served for figure 20. Phase correction led to figure 21. Note that phase correction has a hardly noticeable effect on the spectrum.

The procedure of trapezoidal apodization followed by equalization led to figure 22. Note that the series of lines near 3400 cm^{-1} have vanished.

Finally, the transform was carried out with two-dimensional apodization (fig. 23). This required an extremely lengthy calculation since the Cooley-Tukey^{5/} factoring algorithm was not applicable. Note that the contrast of that series of bands is doubled.

The band contrast is readily understood in terms of spectral transfer function. A uniform band series like that gives a blip in the interferogram, in this case at the leftmost edge of figure 19. The central fringes for this spectral integral lie in the righthand major hump. Thus, the corresponding righthand blip due to the band lies outside the interferogram. In figure 24 we see the three pertinent spectral transfer functions and the location of the blip is indicated.

No apodization leads to a contrast transfer of $\frac{1}{2}$ at the space frequency of the blip. Simple trapezoidal apodization leads to almost zero contrast transfer. Full two-dimensional apodizing leads to unit contrast transfer. The experiments

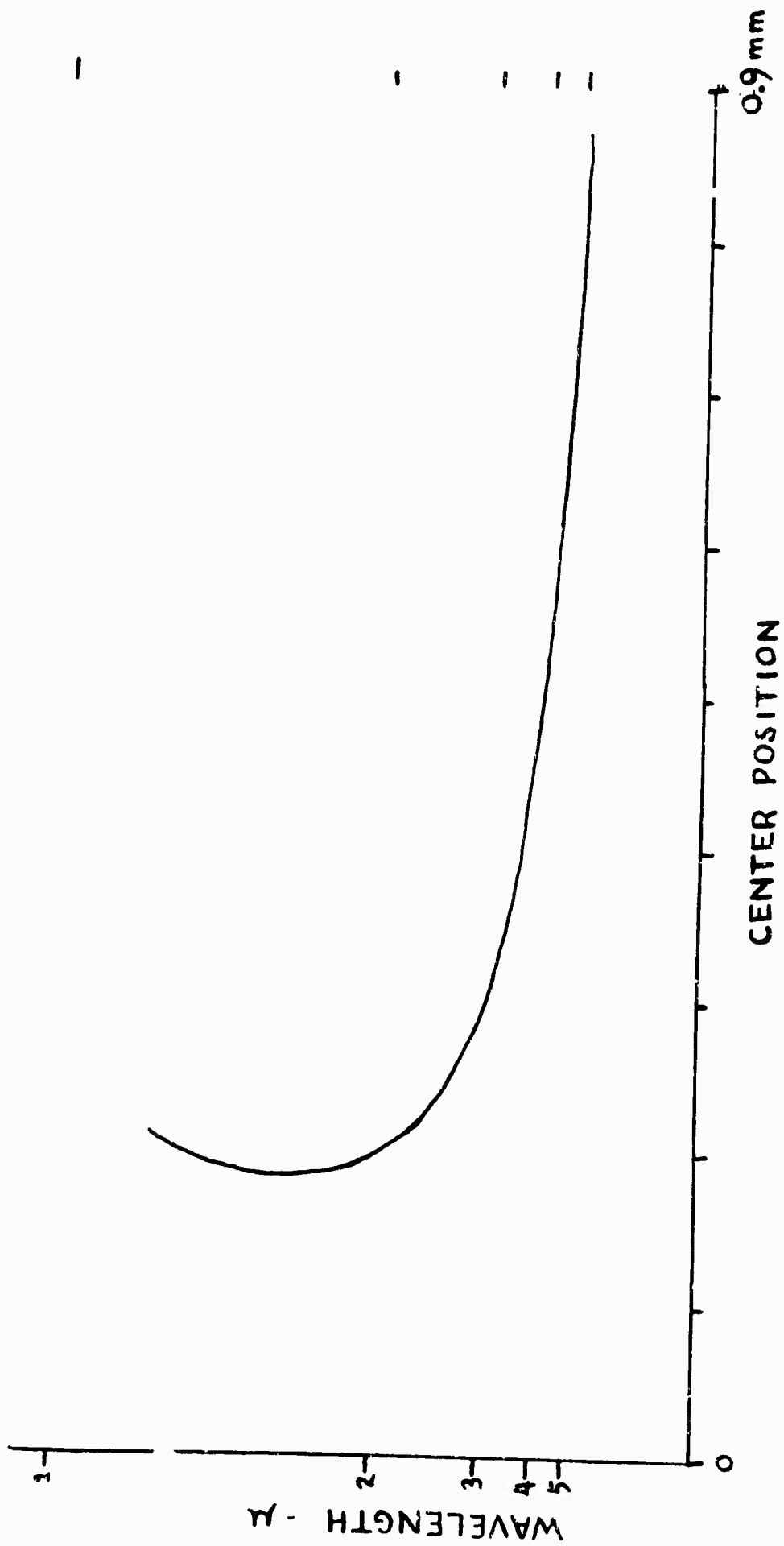

Fig. 19 Wavelength vs. Central fringe position for actual chirped interferometer.

ACETYLENE
ONE SCAN INTERFEROGRAM

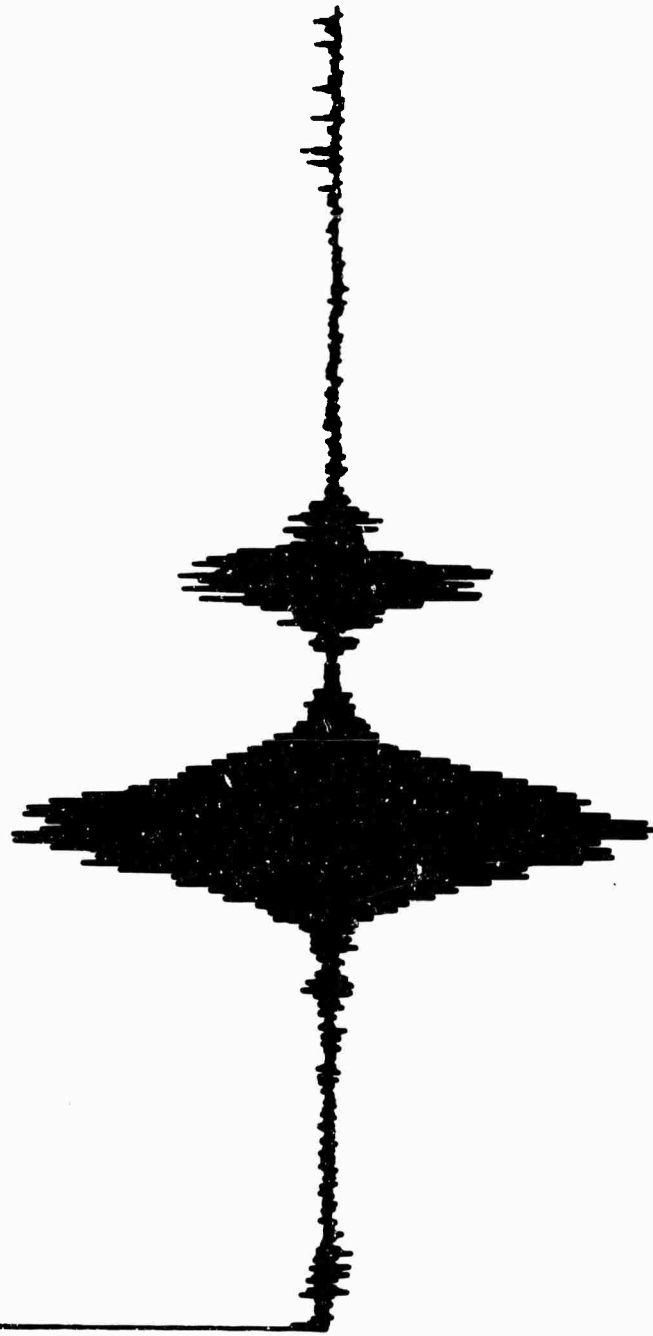

Fig. 19A Chirped interferogram
of acetylene flame source.

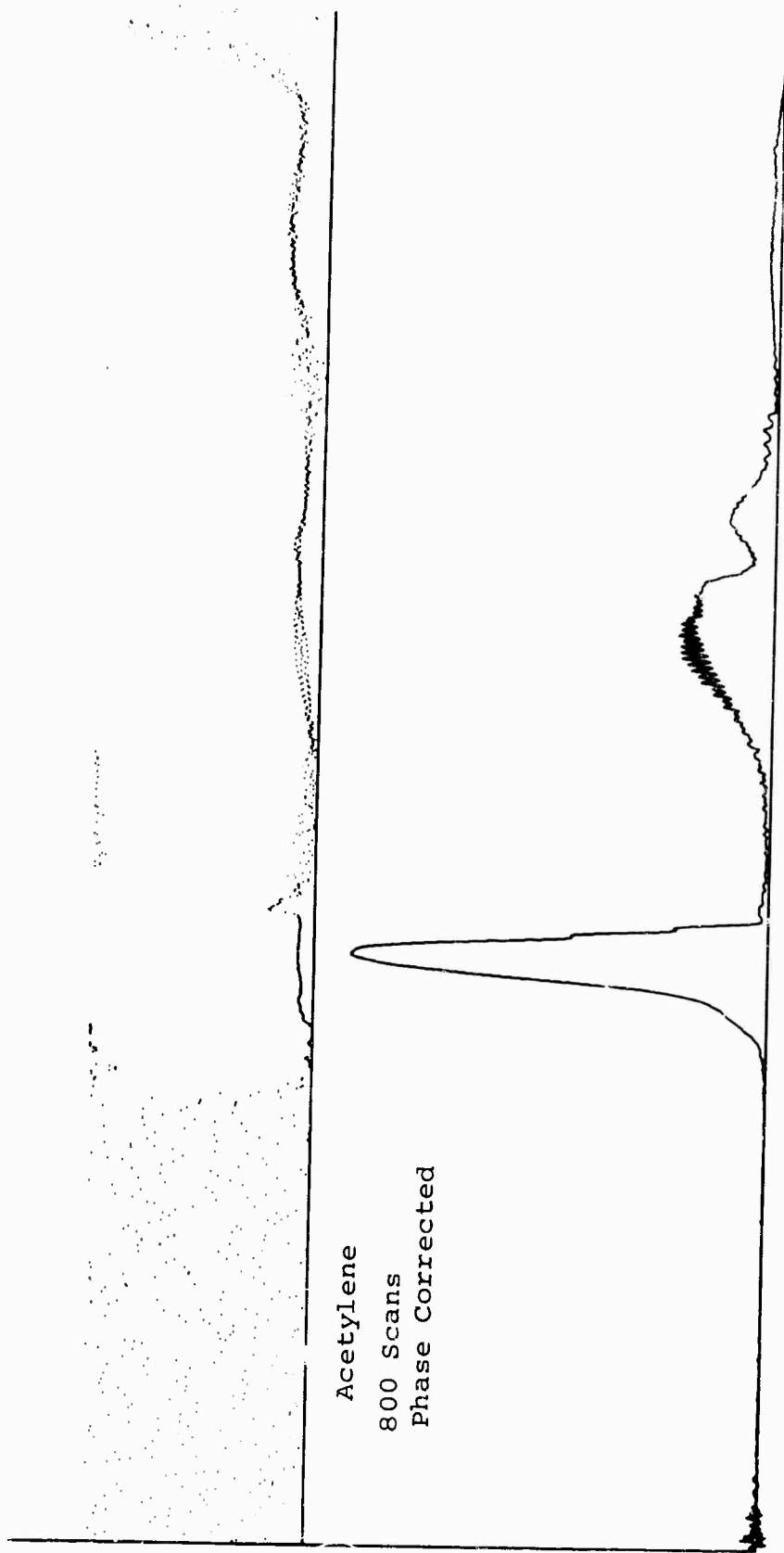

Fig. 21 Phase corrected spectrum.

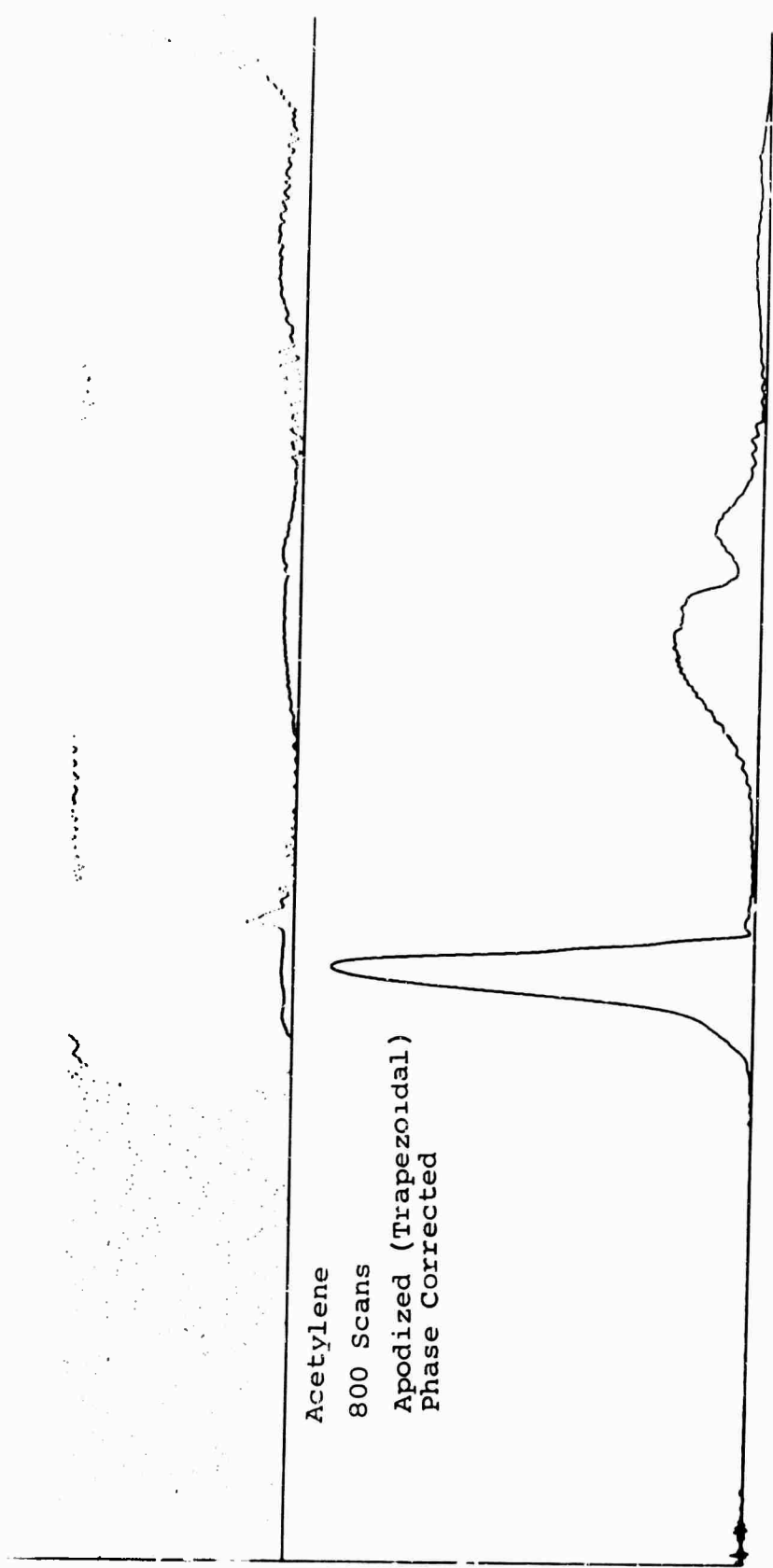

Fig. 22 Spectrum from
trapezoidal apodization, equalized.

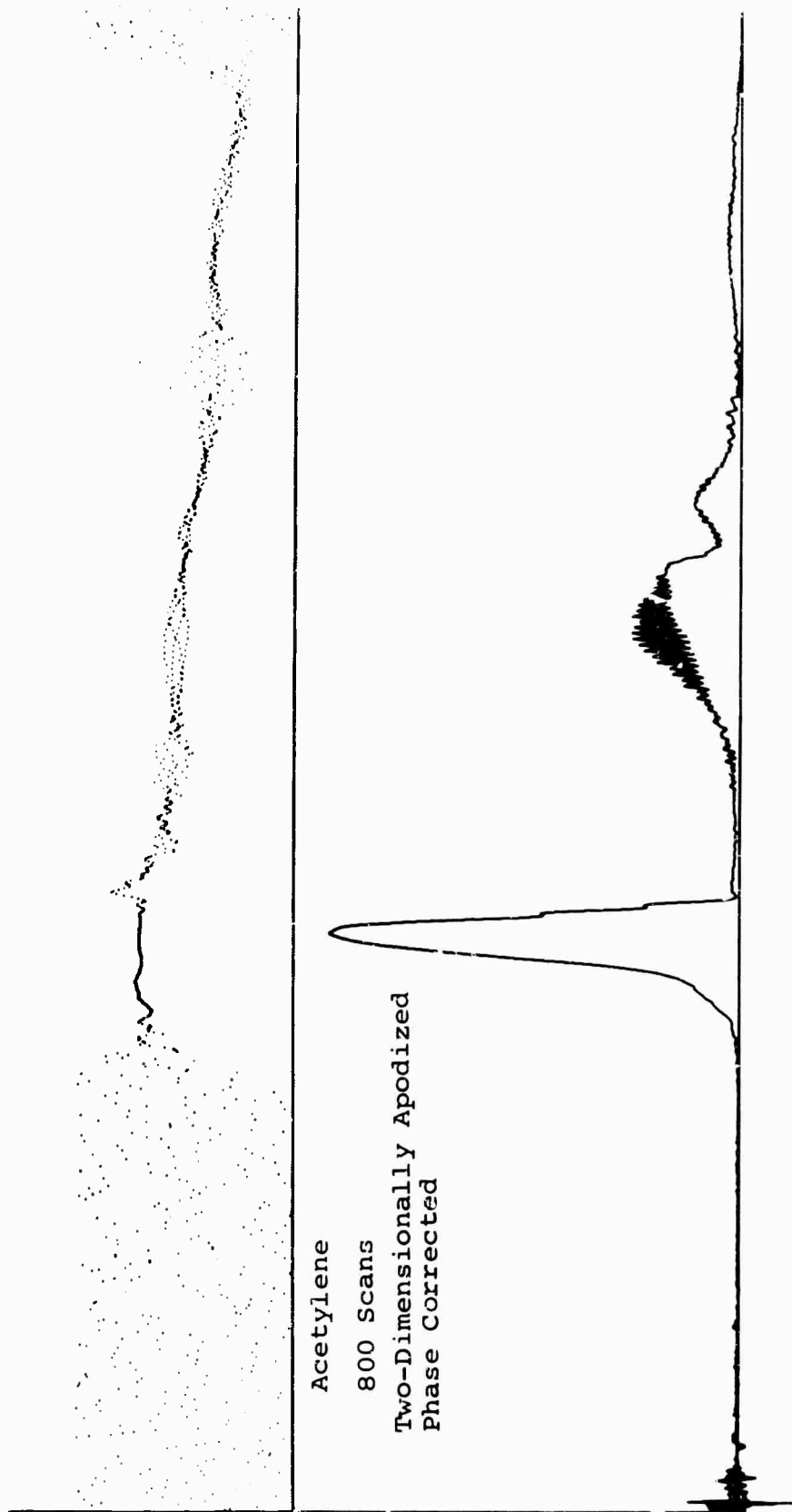

Fig. 23 Spectrum from
two-dimensional apodization.

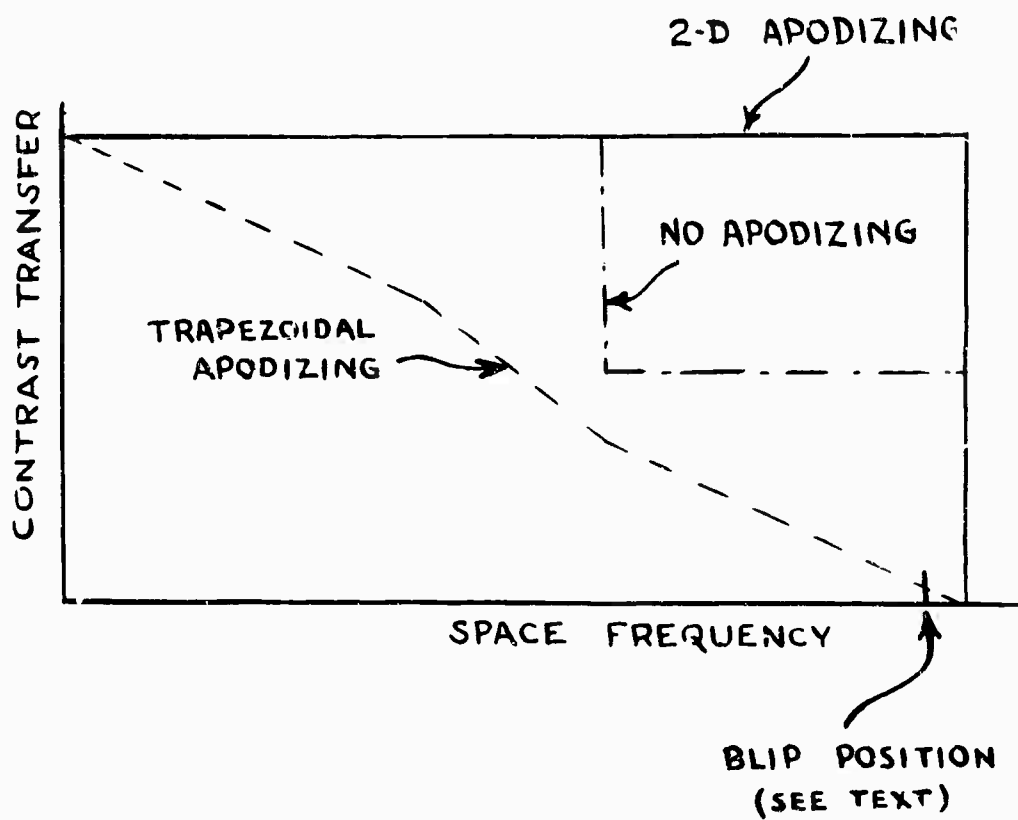

Fig. 24 Spectral transfer functions for bands near 3400 cm^{-1} .

agree perfectly with expectations, and serve to highlight the attributes of the various procedures.

Phase Correction:

Normally, phase correction procedures 1,7,8/ obtain a reference phase spectrum from the narrow group of central fringes. Peripheral fringes are excluded since the reference phase spectrum is known to be smooth (without high resolution detail) and so the peripheral fringes would only contribute noise.

With extremely chirped interferograms there is no narrow group of central fringes and we are obliged to resort to another approach. This approach is to calculate the phase spectrum from a black body source, and use this as a reference phase spectrum after suitable fitting. Suitable fitting involves adjusting only two parameters; the constant and linear terms of the reference phase spectrum. The higher order terms are reproducible.

It turns out to be easy enough to accomplish a visual fit; automating the process is more difficult. The problem is akin to character recognition. None of our attempted methods functioned with complete consistency and many did not function at all, probably due to residual program bugs. Certain aspects are nevertheless worthy of elaboration.

Two problems and the combination thereof prove paramount. One is 360° discontinuities encountered since the phase is mathematically modulo 2π , but physically continuous over many cycles. Such discontinuities must be eliminated if the fitting of the reference phase is to be at all meaningful. The second problem is the wild fluctuations of phase wherever the signal-to-noise ratio is less than unity. These fluctuations have no bearing on the fit and must be properly discriminated against.

As far as the elimination of the discontinuities is concerned, two methods exist. The first is to look for any steps along the phase spectrum greater than π in magnitude. Appropriately adding or subtracting 2π thereafter eliminates the steps.

The discontinuities may be also eliminated by differentiating and integrating the phase spectrum ^{9/}. Since the analysis is discrete finite differences are more legitimate.

$$\Delta\phi_k \cong \phi_{k+1} - \phi_k$$

where ϕ_k is the phase at frequency k . C and S are cosine and sine terms of the Fourier transform.

$$\tan\Delta\phi_k = \frac{C_k S_{k+1} - S_k C_{k+1}}{C_k C_{k+1} + S_k S_{k+1}} \quad (11)$$

It is interesting that when $\Delta\phi_k$ remains small then $\tan\Delta\phi_k \approx \Delta\phi_k$, and the approximate phase spectrum may be generated as successive partial sums of the right hand side.

A very useful mean slope, to determine the center, of an unchirped interferogram may be readily obtained from equation (11). Note that if $C_k \approx C_{k+1}$ and $S_k \approx S_{k+1}$ then the denominator of (11) is A^2 . With this we can very easily create an A^2 weighted average of $\tan\Delta\phi$ as

$$\overline{\tan\Delta\phi} = \frac{\sum_k (C_k S_{k+1} - S_k C_{k+1})}{\sum_k (C_k C_{k+1} + S_k S_{k+1})}, \quad (12)$$

from which we can readily determine the appropriate gradient

$$\overline{\Delta\phi} = \arctan(\overline{\tan\Delta\phi}). \quad (13)$$

This procedure is very simple and elegant and certainly ought to work, in spite of the fact that we did not succeed with it in practice.

The procedure should need only modest variation for chirped interferograms, which would effectually subtract the higher (than first) order terms of the reference phase before averaging.

The only procedure which has so far worked in practice is arbitrarily selecting those segments of the spectrum whose amplitude everywhere exceeds 10% of the maximum amplitude.

360° discontinuities were eliminated by the first process. A least squares line was then fit to the difference between that segment of the phase spectrum and the reference phase spectrum. Differences from this line were finally used as the angle deviations for phase correction.

Describing the Reference Phase:

In order to provide a smooth reference phase spectrum for subsequent computations, the phase spectrum of a black body source is obtained. The 360° discontinuities are eliminated and within the frequency range of good signal-to-noise, a least squares polynomial is fit to the curve.

In practice, with extreme chopping, a considerable number of terms are required for a good fit; too many. Considering the chirping range and required accuracy the situation is not surprising. For the interferometer used in the examples of the section entitled Experimental Results, the phase spectrum spanned about 800 cycles. Considering that the reference phase should be accurate to better than 1/40th cycle, the polynomial need be accurate to better than one part in 30,000.

Polynomial fits of even ninth order did not give sufficient accuracy. The very best obtainable accuracy was about 15°. The error was clearly systematic and furthermore higher order fits proved exceedingly slow in reducing the systematic errors. Thus, ordinary Taylor series are clearly

inappropriate for this situation.

In particular, hyperbolic character is bestowed on the phase spectrum by the dispersion (theoretical) of the chirping material. Fitting a hyperbola with a power series can be discouraging.

The remedy proved to be to start the Taylor series with negative exponents. In this fashion the error was reduced to less than 2° using the -2nd to +5th powers of the frequency. That accuracy is quite sufficient.

SECTION VII
FINAL COMMENT

A quotation from Fellgett is suitable to conclude this report, "A remark on noise: Dynamic range becomes a problem for high, not for low S/N ratio."

APPENDIX

Let us adopt N input samples which give rise to N output frequencies. The proportionality factor in the phase slope versus offset relation is one cycle per sample frequency per sample point. Therefore, if the phase slope is zero at one end of the interferogram, it is unity at the other end. At this far end the phase changes by one cycle per output point. Distributing this slope change uniformly over the output points gives $\ddot{\phi} = 1/N$.

Typically, the sidelobe structure of the instrument profile is thoroughly depicted by less than 20 output points. Thus, if $N = 1000$, the maximum phase error involved is $\frac{1}{2}(20)/1000 = 1/100$ wave. Thus, for each instrument profile (both its symmetric and antisymmetric components as used in the general relation) the interferogram satisfies the stationary phase condition within roughly $1/100$ wave.

LIST OF REFERENCES

1. Mertz, L. (1965) "Transformations in Optics" (John Wiley and Sons).
2. Cornes, J & P., (1966), JOSA 56, 896.
3. Forman, M.L., NASA Report X-622-66-478 (Goddard Space Flight Center, 1966).
4. Steel, W.H., (1964), JOSA 54, 151.
5. Cooley, J.W. and Tukey, J.W., (1965), Math. of Computation 19, 297.
6. Forman, M.L., (1966), JOSA 56, 978.
7. Forman, M.L., Steel, W.H., and Vanasse, G.A., (1966), JOSA 56, 59.
8. Mertz, L., (1967), Infrared Physics 7, 17.
9. Wadsworth, R., and Zachor, A., (private communication).

DOCUMENT CONTROL DATA - R&D

(Security classification of title, body of abstract and indexing annotation must be entered when the overall report is classified)

1 ORIGINATING ACTIVITY (Corporate author) Block Engineering, Inc. 19 Blackstone Street Cambridge, Massachusetts 02139		2a. REPORT SECURITY CLASSIFICATION Unclassified	
		2b. GROUP	
3 REPORT TITLE EXPERIMENTAL STUDY PROGRAM TO INVESTIGATE LIMITATIONS IN FOURIER SPECTROSCOPY			
4 DESCRIPTIVE NOTES (Type of report and inclusive dates) Scientific; Final; 3 January 1967 - 2 January 1968; Approved 12 February 1968			
5 AUTHOR(S) (Last name, first name, initial) Isaiah coleman Lawrence N. Mertz			
6. REPORT DATE January 1968	7a. TOTAL NO. OF PAGES 70	7b. NO. OF REFS 9	
8a. CONTRACT OR GRANT NO. F19628-67-C-0167	ARPA Order No. 450	8b. ORIGINATOR'S REPORT NUMBER(S) Project Numbers 9620 and 9621	
b. PROJECT, Task, Work Unit Nos. 8663-05-01			
c. DOD Element 6250301R		8c. OTHER REPORT NO(S) (Any other numbers that may be assigned this report) AFCRL-68-0050	
d. Dod Subelement P6E30			
10. AVAILABILITY/LIMITATION NOTICES #1 Distribution of this document is unlimited. It may be released to the Clearinghouse, Department of Commerce, for sale to the general public.			
11. SUPPLEMENTARY NOTES This research was supported by the Advanced Research Projects Agency		12. SPONSORING MILITARY ACTIVITY Air Force Cambridge Research Laboratories(CRO) L.G. Hanscom Field, Bedford, Massachusetts 01730	
13 ABSTRACT Fourier spectrometry is at a disadvantage compared to conventional scanners insofar as larger dynamic range is required for recording and/or transmitting the signal. Various procedures for minimizing the disadvantage are evaluated. A simulated experimental comparison is made between signal compression techniques and chirping (distribution of the central fringes of an interferogram). The comparison yields approximately a 15 dB improvement for both procedures, though each leave somewhat different residual distortions of the spectrum. The emphasis is given to the chirping procedure, since this is less well known, and ascenence over its problems provides greater insight into Fourier spectrometry.			

14	KEY WORDS	LINK A		LINK B		LINK C	
		ROLE	WT	ROLE	WT	ROLE	WT
Fourier Spectrometry Spectrometry							

INSTRUCTIONS

1. **ORIGINATING ACTIVITY:** Enter the name and address of the contractor, subcontractor, grantee, Department of Defense activity or other organization (*corporate author*) issuing the report.
- 2a. **REPORT SECURITY CLASSIFICATION:** Enter the overall security classification of the report. Indicate whether "Restricted Data" is included. Marking is to be in accordance with appropriate security regulations.
- 2b. **GROUP:** Automatic downgrading is specified in DoD Directive 5200.10 and Armed Forces Industrial Manual. Enter the group number. Also, when applicable, show that optional markings have been used for Group 3 and Group 4 as authorized.
3. **REPORT TITLE:** Enter the complete report title in all capital letters. Titles in all cases should be unclassified. If a meaningful title cannot be selected without classification, show title classification in all capitals in parentheses immediately following the title.
4. **DESCRIPTIVE NOTES:** If appropriate, enter the type of report, e.g., interim, progress, summary, annual, or final. Give the inclusive dates when a specific reporting period is covered.
5. **AUTHOR(S):** Enter the name(s) of author(s) as shown on or in the report. Enter last name, first name, middle initial. If military, show rank and branch of service. The name of the principal author is an absolute minimum requirement.
6. **REPORT DATE:** Enter the date of the report as day, month, year, or month, year. If more than one date appears on the report, use date of publication.
- 7a. **TOTAL NUMBER OF PAGES:** The total page count should follow normal pagination procedure, i.e., enter the number of pages containing information.
- 7b. **NUMBER OF REFERENCES:** Enter the total number of references cited in the report.
- 8a. **CONTRACT OR GRANT NUMBER:** If appropriate, enter the applicable number of the contract or grant under which the report was written.
- 8b, 8c, & 8d. **PROJECT NUMBER:** Enter the appropriate military department identification, such as project number, subproject number, system numbers, task number, etc.
- 9a. **ORIGINATOR'S REPORT NUMBER(S):** Enter the official report number by which the document will be identified and controlled by the originating activity. This number must be unique to this report.
- 9b. **OTHER REPORT NUMBER(S):** If the report has been assigned any other report numbers (*either by the originator or by the sponsor*), also enter this number(s).
10. **AVAILABILITY/LIMITATION NOTICES:** Enter any limitations on further dissemination of the report, other than those

imposed by security classification, using standard statements such as:

- (1) "Qualified requesters may obtain copies of this report from DDC."
- (2) "Foreign announcement and dissemination of this report by DDC is not authorized."
- (3) "U. S. Government agencies may obtain copies of this report directly from DDC. Other qualified DDC users shall request through _____."
- (4) "U. S. military agencies may obtain copies of this report directly from DDC. Other qualified users shall request through _____."
- (5) "All distribution of this report is controlled. Qualified DDC users shall request through _____."

If the report has been furnished to the Office of Technical Services, Department of Commerce, for sale to the public, indicate this fact and enter the price, if known.

11. **SUPPLEMENTARY NOTES:** Use for additional explanatory notes.
12. **SPONSORING MILITARY ACTIVITY:** Enter the name of the departmental project office or laboratory sponsoring (*paying for*) the research and development. Include address.
13. **ABSTRACT:** Enter an abstract giving a brief and factual summary of the document indicative of the report, even though it may also appear elsewhere in the body of the technical report. If additional space is required, a continuation sheet shall be attached.

It is highly desirable that the abstract of classified reports be unclassified. Each paragraph of the abstract shall end with an indication of the military security classification of the information in the paragraph, represented as (TS), (S), (C), or (U).

There is no limitation on the length of the abstract. However, the suggested length is from 150 to 225 words.

14. **KEY WORDS:** Key words are technically meaningful terms or short phrases that characterize a report [...] may be used as index entries for cataloging the report. Key words must be selected so that no security classification is required. Identifiers, such as equipment model designation, trade name, military project code name, geographic location, may be used as key words but will be followed by an indication of technical context. The assignment of links, rules, and weights is optional.