

ESD RECORD COPY

ESD-TR-67-423

RETURN TO

MTR-528

SCIENTIFIC & TECHNICAL INFORMATION DIVISION
(ESTI), BUILDING 1211

ESD ACCESSION LIST

ESTI Call No. **59519**

Copy No. of cys.

THE PERFORMANCE OF A SIMULATED CONVOLUTIONAL DECODER
ON MEASURED HF AND TROPOSPHERIC DATA CHANNELS

JANUARY 1968

K. Brayer

Prepared for

AEROSPACE INSTRUMENTATION PROGRAM OFFICE

ELECTRONIC SYSTEMS DIVISION
AIR FORCE SYSTEMS COMMAND
UNITED STATES AIR FORCE
L. G. Hanscom Field, Bedford, Massachusetts



Project 705B

Prepared by

THE MITRE CORPORATION

Bedford, Massachusetts

Contract AF19(628)-5165

This document has been approved for public release and sale; its distribution is unlimited.

ADD 6666074

ESD-TR-67-423
ESTI FILE COPY

When U.S. Government drawings, specifications, or other data are used for any purpose other than a definitely related government procurement operation, the government thereby incurs no responsibility nor any obligation whatsoever; and the fact that the government may have formulated, furnished, or in any way supplied the said drawings, specifications, or other data is not to be regarded by implication or otherwise, as in any manner licensing the holder or any other person or corporation, or conveying any rights or permission to manufacture, use, or sell any patented invention that may in any way be related thereto.

Do not return this copy. Retain or destroy.

THE PERFORMANCE OF A SIMULATED CONVOLUTIONAL DECODER
ON MEASURED HF AND TROPOSPHERIC DATA CHANNELS

JANUARY 1968

K. Brayer

Prepared for

AEROSPACE INSTRUMENTATION PROGRAM OFFICE

ELECTRONIC SYSTEMS DIVISION
AIR FORCE SYSTEMS COMMAND
UNITED STATES AIR FORCE
L. G. Hanscom Field, Bedford, Massachusetts



This document has been approved for public
release and sale; its distribution is un-
limited.

Project 705B
Prepared by
THE MITRE CORPORATION
Bedford, Massachusetts
Contract AF19(628)-5165

FOREWORD

This report was prepared by the Communications Techniques Department of The MITRE Corporation, Bedford, Massachusetts, under Contract AF 19(628)-5165. The work was directed by the Development Engineering Division under the Aerospace Instrumentation Program Office, Air Force Electronic Systems Division, Laurence G. Hanscom Field, Bedford, Massachusetts. Robert E. Forney served as the Air Force Project Engineer for this program, identifiable as ESD (ESSID) Project 5932, Range Digital Data Transmission Improvement.

REVIEW AND APPROVAL

This technical report has been reviewed and is approved.

OTIS R. HILL, Colonel, USAF
Director of Aerospace Instrumentation
Program Office

ABSTRACT

A Massey diffuse convolutional decoder was simulated in the IBM 7030 computer and used to decode binary digital error patterns measured at 2400 bits/sec on an HF radio circuit and on a multiple link data circuit dominated by a tropospheric scatter path. It was found that the simulation performed at least as well as previous cyclic code simulations on HF radio and better than cyclic codes on the tropospheric path.

TABLE OF CONTENTS

	<u>Page</u>	
LIST OF ILLUSTRATIONS	vi	
LIST OF TABLES	vii	
SECTION I	INTRODUCTION	1
	The Massey Diffuse Code	2
	Description of the Data	5
SECTION II	SIMULATION RESULTS	9
	Cumulative Performance Curves	23
SECTION III	CONVOLUTIONAL CODE ERROR PROPAGATION	26
SECTION IV	COMPARISON OF THE CONVOLUTIONAL TECHNIQUE TO CYCLIC CODING	29
SECTION V	CONCLUSIONS	34
REFERENCES		35

LIST OF ILLUSTRATIONS

<u>Figure Number</u>		<u>Page</u>
1	Massey Diffuse Convolutional Decoder	4
2	Full Duplex Communication Circuit Configuration	6
3	Simulation Test Results, $B=6$, Improvement Factor (F) Versus Channel Average Bit Error-Rate (P_e)	11
4	Simulation Test Results, $B=140$, Improve- ment Factor (F) Versus Channel Average Bit Error-Rate (P_e)	12
5	Simulation Test Results, $B=284$, Improve- ment Factor (F) Versus Channel Average Bit Error-Rate (P_e)	13
6	Simulation Test Results, $B=572$, Improve- ment Factor (F) Versus Channel Average Bit Error-Rate (P_e)	14
7	Simulation Test Results, $B=1196$, Improve- ment Factor (F) Versus Channel Average Bit Error-Rate (P_e)	15
8	Simulation Test Results, $B=6$, Improvement Factor (F) Versus Channel Average Bit Error-Rate (P_e)	18
9	Simulation Test Results, $B=144$, Improve- ment Factor (F) Versus Channel Average Bit Error-Rate (P_e)	19
10	Simulation Test Results, $B=288$, Improve- ment Factor (F) Versus Channel Average Bit Error-Rate (P_e)	20
11	Simulation Test Results, $B=576$, Improve- ment Factor (F) Versus Channel Average Bit Error-Rate (P_e)	21
12	Simulation Test Results, $B=1200$, Improve- ment Factor (F) Versus Channel Average Bit Error-Rate (P_e)	22
13	Cumulative Performance of Massey Code in HF Channel	24
14	Cumulative Performance of Massey Code in Tropospheric Channel	25
15	Simulation Test Results of Interleaved Cyclic Code with Three Seconds Delay, Improvement Factor (F) Versus Channel Average Bit Error-Rate (P_e)	31
16	Comparative Performance of Massey and Cyclic Codes for Equal Delay	33

LIST OF TABLES

<u>Table Number</u>		<u>Page</u>
I	Delay Due to Decoding	7
II	Output Error Rate as a Function of B in the HF Channel	10
III	Output Error Rate as a Function of B in the Tropospheric Channel	16
IV	% of Output Errors that are Uncorrected Input Errors, HF Data Runs	27
V	% of Output Errors that are Uncorrected Input Errors, Tropo Data Runs	28
VI	Performance of Golay Code on Tropospheric Channel	30

SECTION I
INTRODUCTION

The wide-scale application of high-speed digital computers for information processing in data management and process control systems has resulted in an increased demand for digital communications. This demand has been met by the development of digital data transmission devices for the existing analog communications plant.

Due to the inherent redundancy of most analog communication, the quality of the transmission media is not particularly critical to the attainment of satisfactory information exchange. However, in the case of digital communication an unacceptable occurrence of errors may be introduced in the transmission process if suitable redundancy is not incorporated into the transmitted data stream. The attainment of acceptable digital error performance using cable, microwave and communication satellite links has been achieved primarily by careful circuit engineering with provision of adequate signal to noise margins. On media such as high-frequency radio and tropo-scatter the same quality of link engineering cannot always be achieved. Consequently, the incorporation of error control has been of particular interest with emphasis on applications to digital data transmission on poor quality links. This error control is effected through the addition of controlled redundancy to the transmitted data stream in the form of the binary digital coding technique which permits the

detection and/or correction of errors by the error control device installed at the receive terminal.

Among the coding techniques that have been developed for error control purposes is the Massey diffuse convolutional code [1]. In this paper, the results of a computer simulation of the performance capabilities of this coding technique against measured real channel error patterns is investigated. The use of a valid computer simulation permits a controlled (repeatable) investigation of the performance of error control in a manner which would not be possible in field environment tests.

The Massey Diffuse Code

The Massey diffuse code [1] evaluated in this paper is a 1/2 rate code (i.e. the code supplies one redundant bit per source information bit.) The encoder accepts from the source information bits (i) at a clock interval (t). Since the error data is for 2400 bit/sec channels and the code rate is 1/2, the clock interval (t) corresponds to 1200 bits/sec. Redundant (parity) bits are calculated according to the relationship:

$$P_t = i_t + i_{t-x} + i_{t-2x} + i_{t-(3x+1)} \quad (1)$$

where i represents an information bit

p represents a parity bit

x is some specific number of clock intervals and addition is mod 2 with no carry.

The pair of bits p_t and i_t are then transmitted over the channel.

The received bits (both information and parity) are entered into the decoder (Fig. 1). In the decoder syndromes (S) are formed in accordance with the following relations:

$$\begin{aligned}
 S_1 &= ei_1 + ep_1 \\
 S_{x+1} &= ei_1 + ei_{x+1} + ep_{x+1} \\
 S_{2x+1} + S_{3x+1} &= ei_1 + ei_{3x+1} + ep_{2x+1} + ep_{3x+2} \\
 S_{3x+2} &= ei_1 + ei_{x+2} + ei_{2x+2} + ei_{3x+2} + ep_{3x+2}
 \end{aligned} \tag{2}$$

$$\text{where } ei_t \text{ or } ep_t = \begin{cases} 1 & \text{if the bit was in error} \\ 0 & \text{otherwise} \end{cases}$$

The fact that the error bits are used is seen by examining the decoder structure and equation (1). If equation (1) is satisfied, the output of the initial information and parity addition will be zero. The decoding rule is to change i_1 if the sum of equations (2) is greater than 2. This criterion will be correct if not more than two of the eleven bits in equations (2) are in error.

The encoder when supplied with an information message of all binary 0's will calculate the parity to be all binary 0's. This allows for the simplification of the simulation in that if all zero information is encoded and the bit-by-bit channel errors are added to the encoder output mod 2 with no carry, the result is the error patterns. Thus, it is only necessary to provide the error patterns as input to a simulated decoder and record the errors which are output

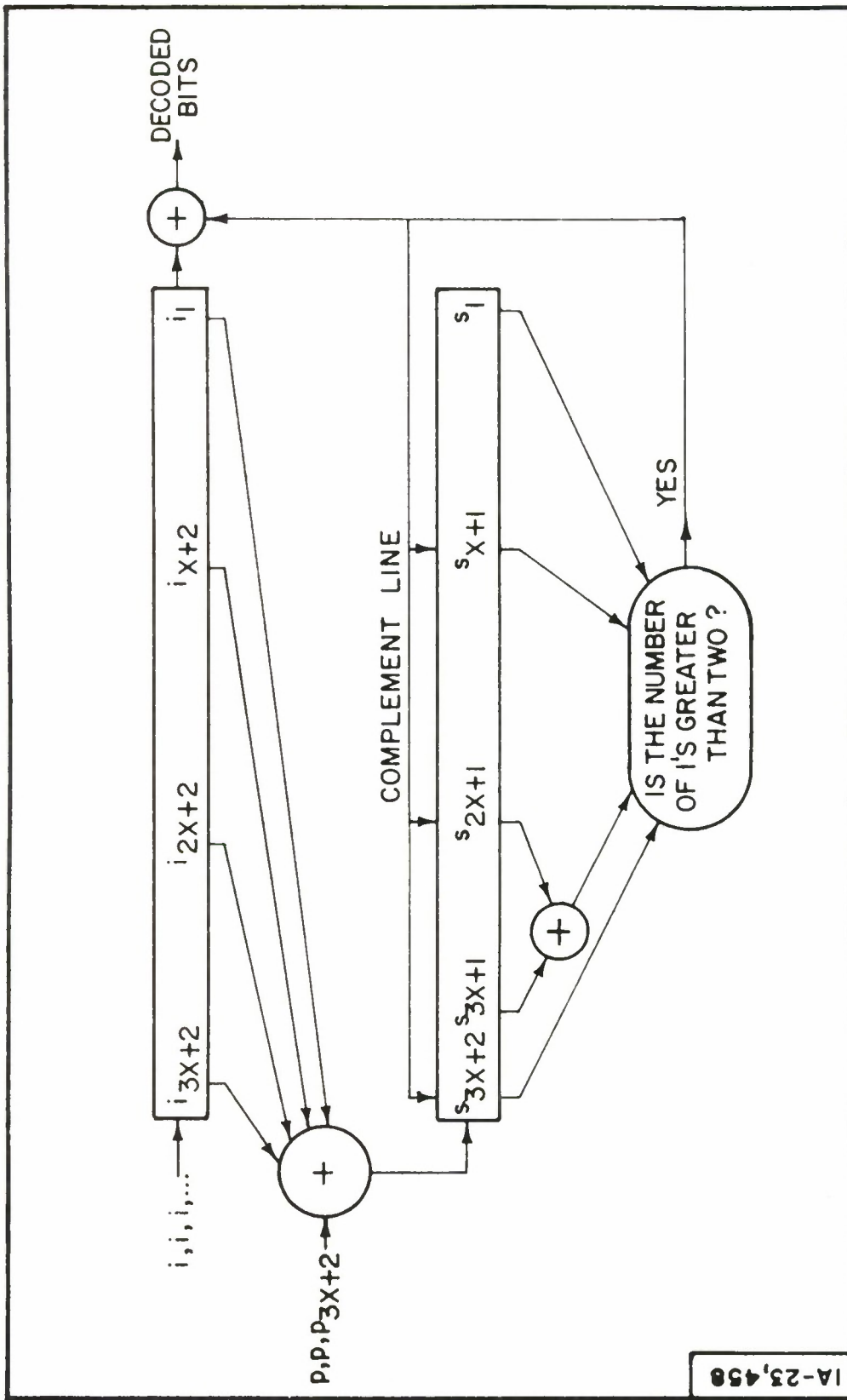

Figure 1 Massey Diffuse Convolutional Decoder

from the decoder.

The decoder while correcting errors also introduces delay into the communication system to which it is applied. This delay is a function of the parameter x (identified as B in the simulation program) and is presented in Table I.

Description of the Data

The error data, have been described in detail previously [2, 3, 4] and will be briefly reviewed here. In October of 1965, field tests were conducted on NRD HF circuits between Antigua and Ascension Islands to collect HF digital error patterns [2, 3]. Tests were conducted for 10 minute periods (runs) at 2400 bits/sec using a Kineplex TE-216 phase-shift-keyed 16 tone modem. The procedure was to transmit a 52 bit test message from Antigua to Ascension and back to Antigua on a looped basis. At Antigua the received message was compared with a suitably delayed replica of the 52-bit test message, and bits which were not in agreement were declared in error. The results were recorded on magnetic tape and converted to IBM seven-track format magnetic tape for use in the IBM 7030 computer. The other data was collected [4] in the spring of 1966 on a link (Fig. 2) characterized as having three types of transmission media: wireline, microwave and troposcatter. The troposcatter is multiple-hop, and the wireline consists of the interconnection of numerous leased telephone wirelines. The dominant sub-path is a troposcatter hop of 583 miles. During the test Sebit 24B vestigial sideband AM modems

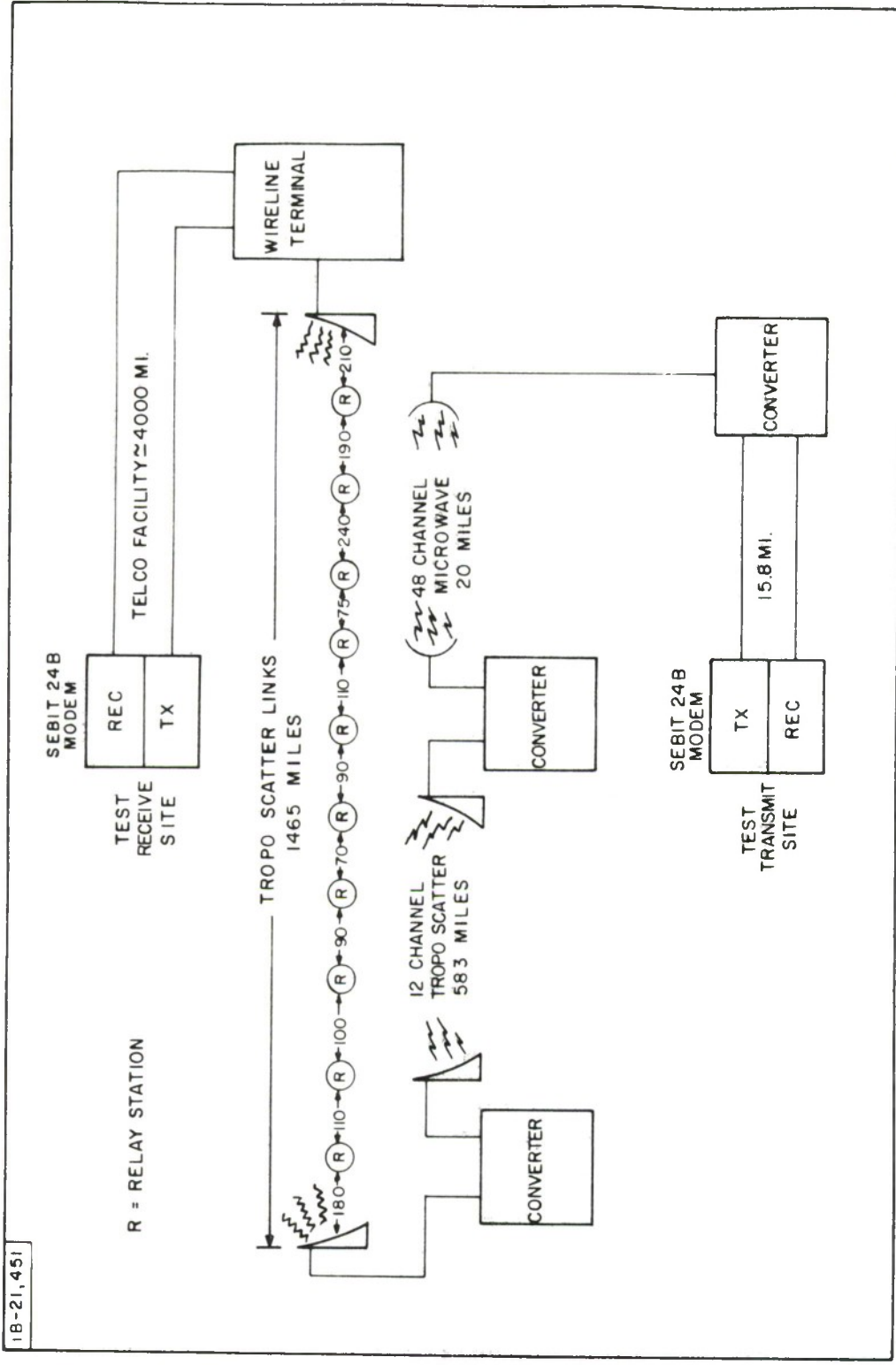

Figure 2 Full Duplex Communication Circuit Configuration

Table I

DELAY DUE TO DECODING

<u>B=X</u>	<u>Delay (Sec.)</u>
6	.015
140	.350
144	.360
284	.710
288	.720
572	1.43
576	1.44
1196	2.99
1200	3.00

were used at 2400 bits/sec in a 4 KHz channel which was FM multiplexed with other channels for transmission on the dominant sub-path. The test procedure was the same as for the HF tests except that the transmission was on a one way basis and runs were 90 minutes long.

Analysis of the HF data [2, 3] indicates that errors occur in bursts and are in no way random. A typical burst is from two to four thousand bits long and has an error density of 5%. Bursts are separated by intervals which have a low error density and vary in length from one-tenth the length of the burst they follow to one-million times the burst length. Additionally, periodic errors of spacing 32 bits occur due to tone interference on individual tones of the TE-216 modem. The data collected on the multiple-hop path consisted of bursts that varied in length from a few hundred bits to tens of thousands of bits where for the most part the density of errors was 75%. The intervals between bursts were error-free and varied from one-tenth the length of the burst they followed to one million times the length.

SECTION II SIMULATION RESULTS

Each of the HF channel test runs listed in Table II was processed through the computer simulation of the Massey diffuse decoder. The output error patterns were recorded on magnetic tape for further statistical processing. The gross results of performance on the HF data will be presented in terms of output average error rate versus B in Table II and as improvement factor in Figures 3 through 7.

$$\text{where Improvement Factor (F)} = \frac{\text{Channel Average Error Rate (P}_e\text{)}}{\text{Output Info. Average Error Rate (P}_c\text{)}} \quad (3)$$

Values of P_e and P_c are presented in Fortran floating point notation. The decoder gives from one to three orders of magnitude improvement with 100% error correction on numerous runs. Further, the improvement increases with B (i.e. as delay is increased performance increases). The values of B were selected to give a range of delay and were adjusted such that bits on the same tone were not encoded together. This eliminates the possibility that the periodic errors will affect an information bit and all of its associated parity bits in the channel and thereby cause decoding errors. In no case was the output average error rate (P_c) greater than the channel average error rate (P_e). The decoder did not degrade the communication channel.

The results for the tropospheric data are presented in Table III and Figures 8 through 12. Since this data was collected on a channel

Table II

OUTPUT ERROR RATE AS A FUNCTION OF B IN THE HF CHANNEL

Run #	Input Error Rate	Output Error Rate				
		B=6	B=140	B=284	B=572	B=1196
333	3.5E-5	0	0	0	0	0
324	7.6E-5	0	0	0	0	0
291	7.8E-5	0	0	0	0	0
318	1.2E-4	2.3E-5	0	0	0	0
321	1.3E-4	0	0	0	0	0
345	6.0E-4	1.5E-4	1.4E-5	1.7E-5	6.5E-6	1.0E-5
354	6.1E-4	7.7E-5	8.9E-6	1.1E-5	8.9E-6	6.0E-6
248	6.2E-4	1.7E-4	0	0	0	0
258	7.6E-4	1.0E-4	6.5E-5	7.7E-5	7.3E-5	5.1E-5
315	1.7E-3	3.45E-4	2.4E-4	2.2E-5	9.6E-5	5.7E-5
342	2.8E-3	1.0E-4	4.6E-5	4.6E-5	4.2E-5	7.1E-5
264	2.9E-3	3.0E-4	1.4E-4	1.7E-4	4.0E-5	2.5E-5
309	4.3E-3	1.8E-4	9.5E-5	7.2E-5	6.8E-5	2.2E-5
261	9.2E-3	2.1E-3	1.6E-3	1.5E-3	1.5E-3	8.6E-4
312	9.3E-3	2.2E-3	9.6E-4	1.0E-3	9.6E-4	6.7E-4
249	1.0E-2	1.2E-3	9.5E-4	9.0E-4	1.0E-3	9.3E-4
339	1.2E-2	2.7E-3	1.4E-3	1.3E-3	1.2E-3	1.1E-3

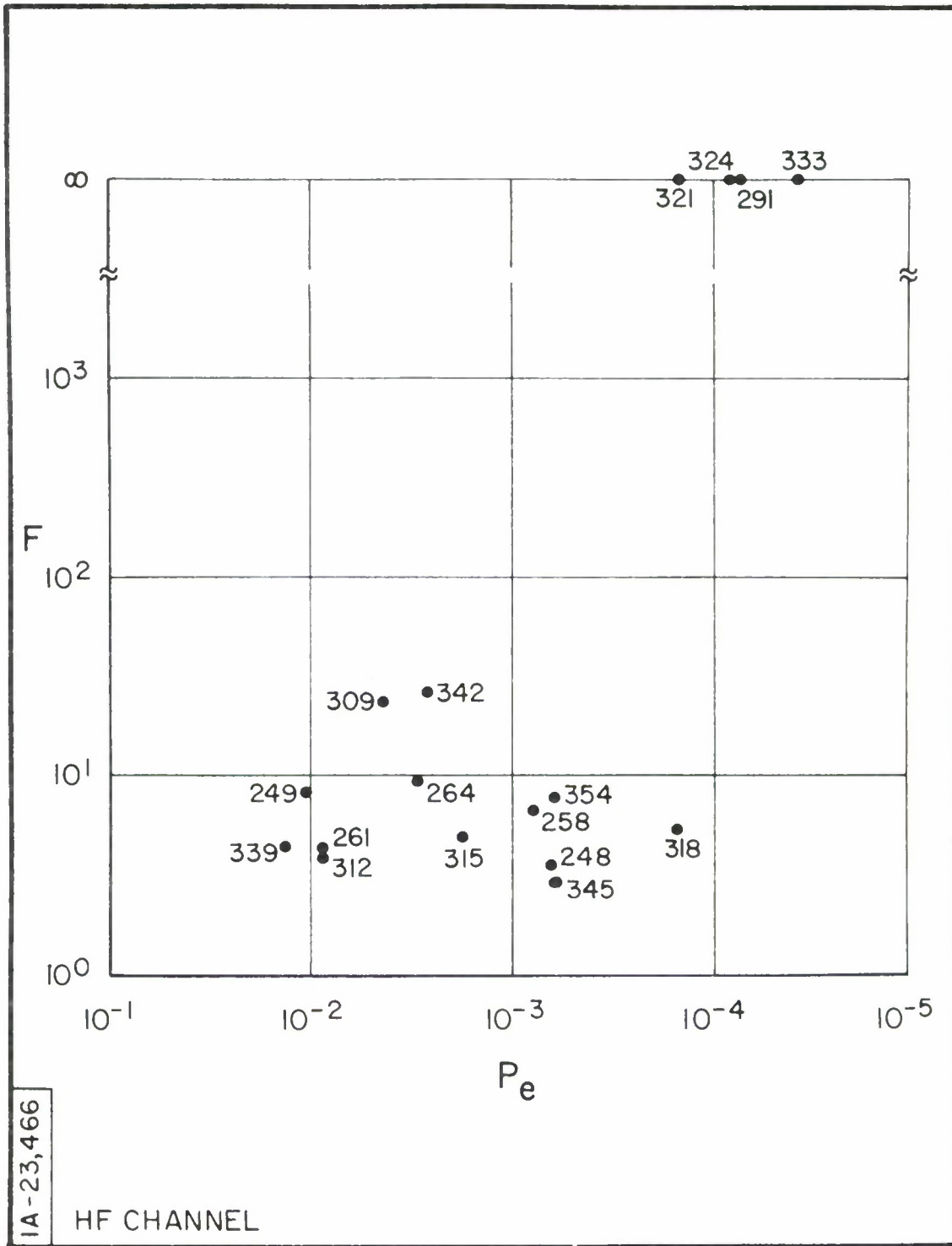

Figure 3 Simulation Test Results, $B = 6$
Improvement Factor (F) Versus Channel Average Bit Error-Rate (P_e)

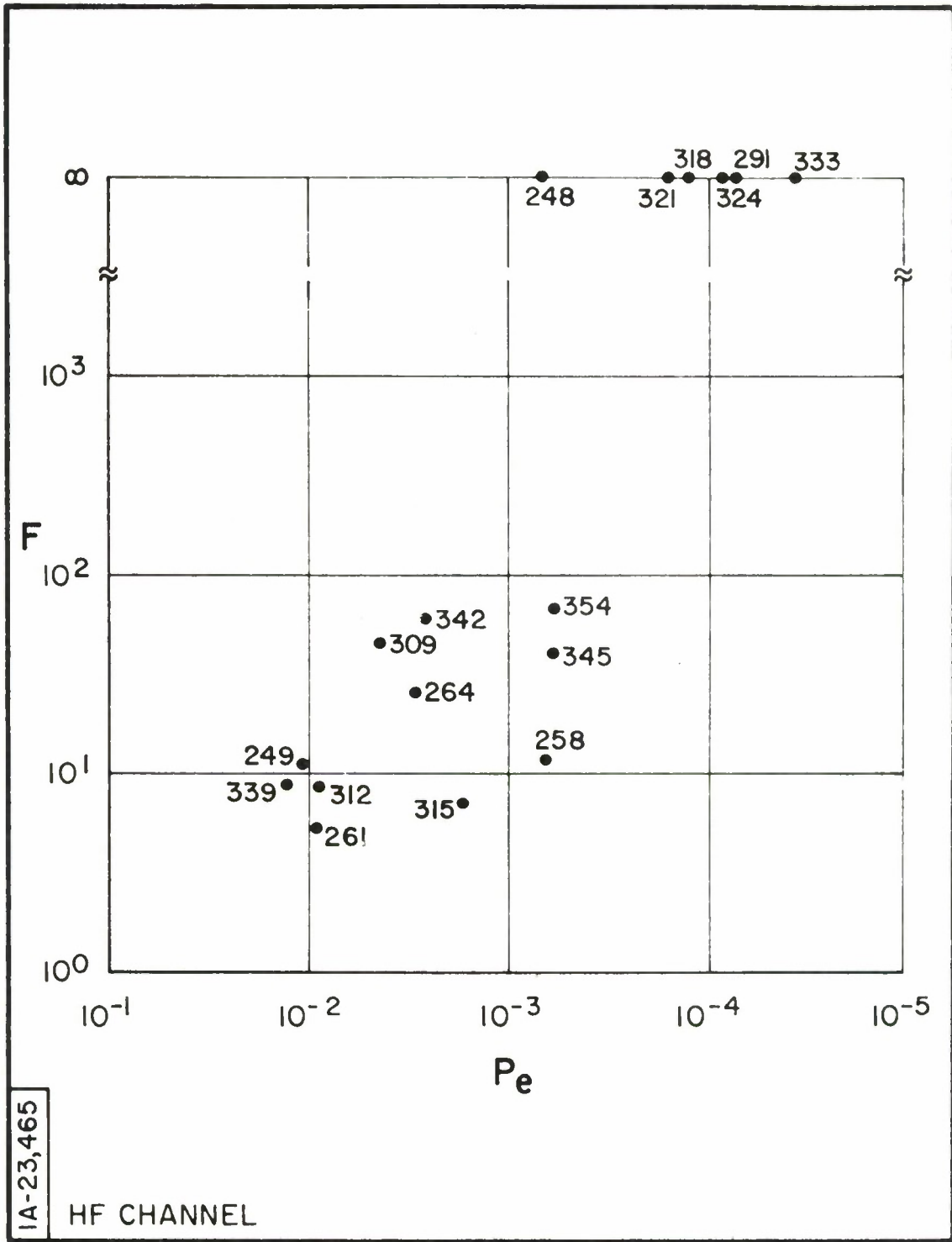

Figure 4 Simulation Test Results, $B = 140$
Improvement Factor (F) Versus Channel Average Bit Error-Rate (P_e)

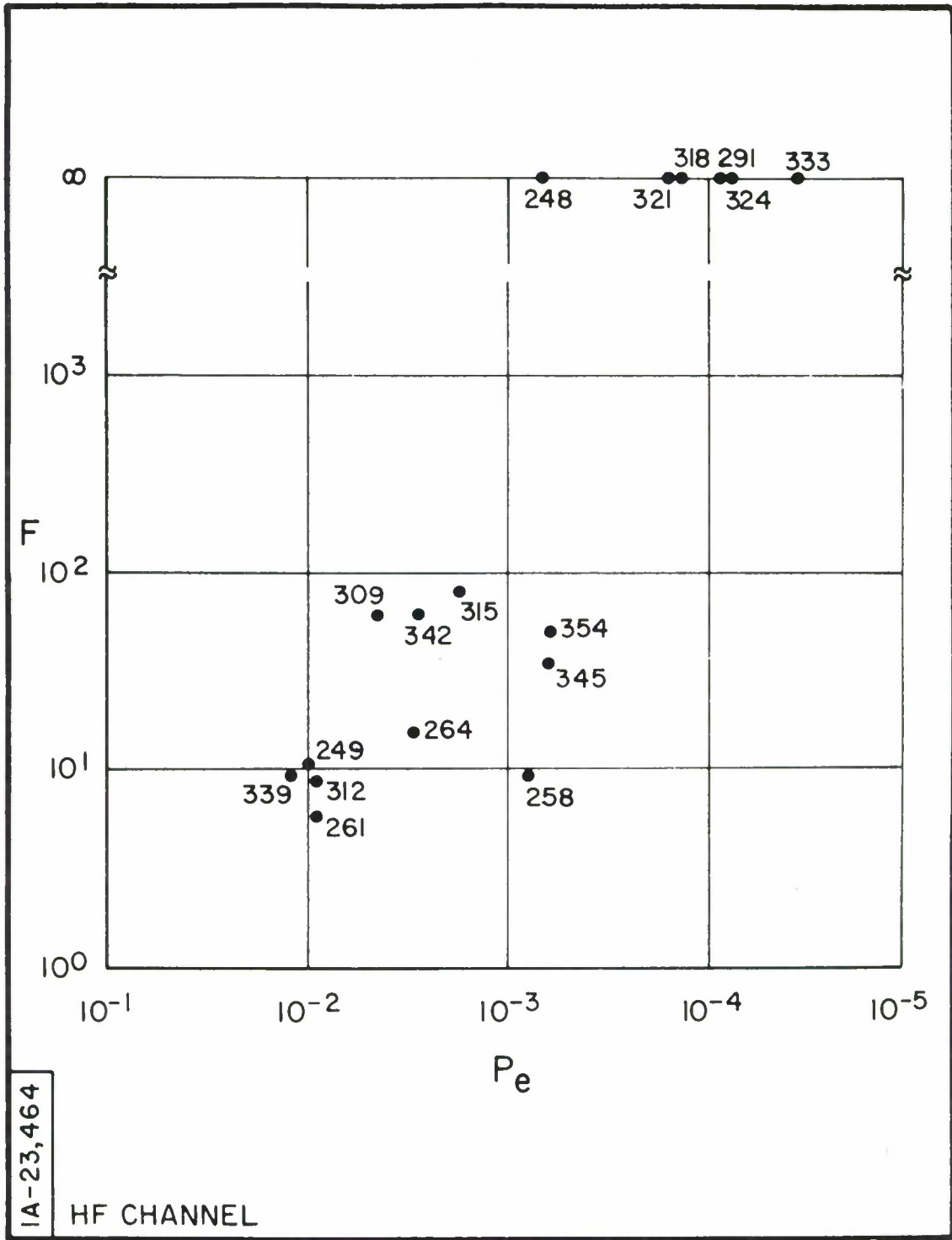

Figure 5 Simulation Test Results, $B = 284$
Improvement Factor (F) Versus Channel Average Bit Error-Rate (P_e)

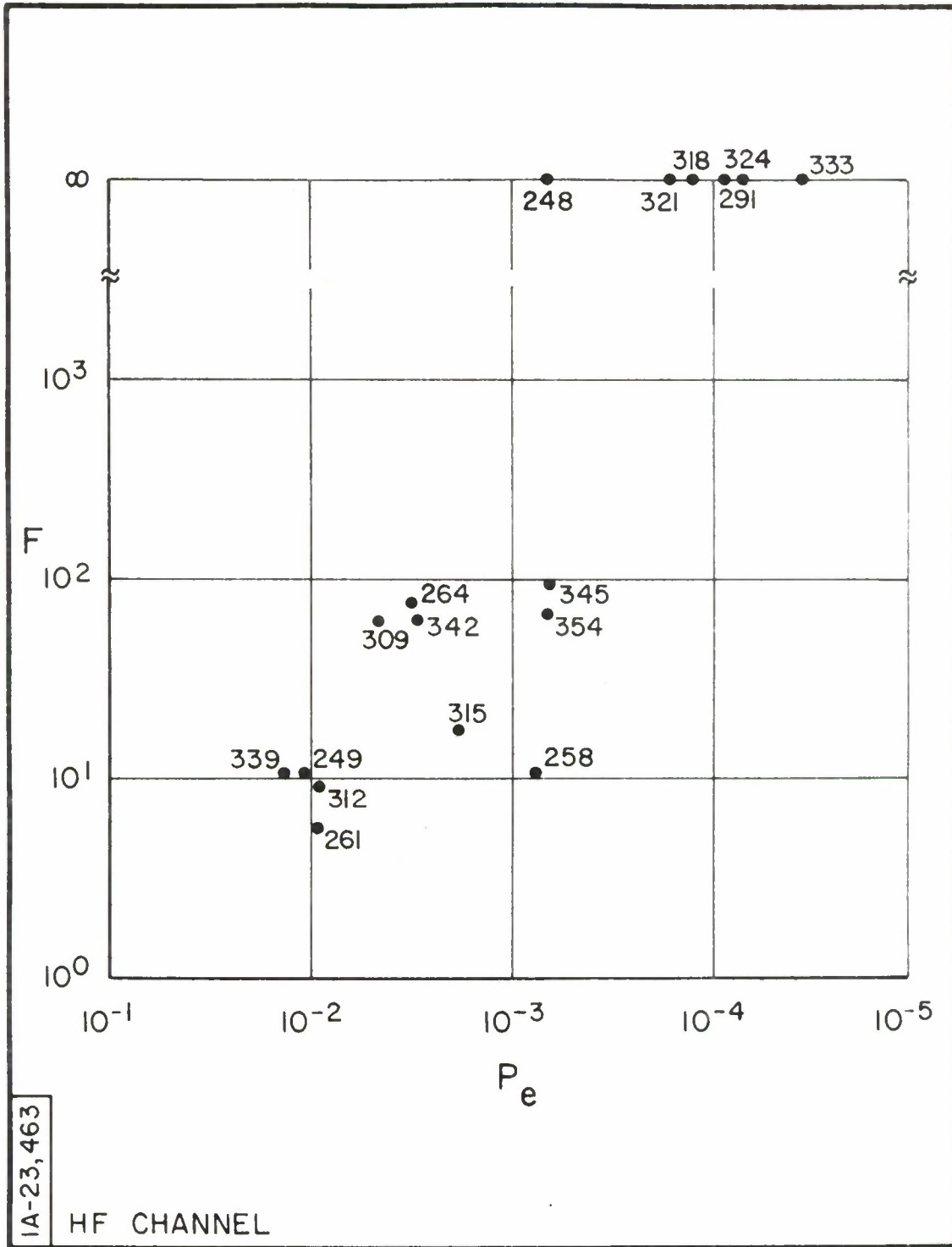

Figure 6 Simulation Test Results, B = 572
Improvement Factor (F) Versus Channel Average Bit Error-Rate (P_e)

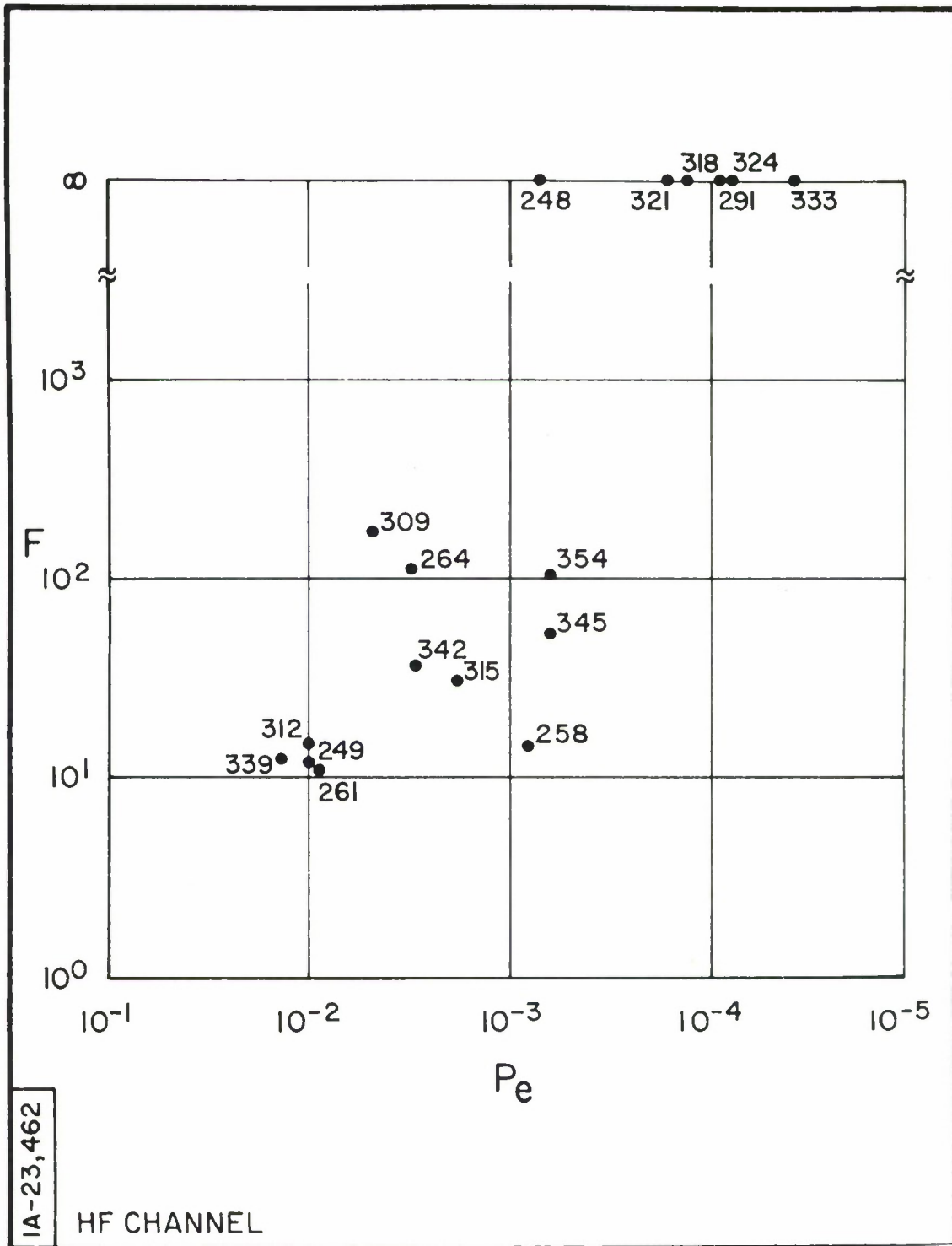

Figure 7 Simulation Test Results, $B = 1196$
Improvement Factor (F) Versus Channel Average Bit Error-Rate (P_e)

Table III

OUTPUT ERROR RATE AS A FUNCTION OF B IN THE
TROPOSPHERIC CHANNEL

Run #	Input Error Rate	Output Error Rate				
		B=6	B=144	B=288	B=576	B=1200
60	1.2E-5	9.7E-6	1.4E-6	0	0	0
64	2.0E-5	3.6E-6	0	0	0	0
61	2.4E-5	1.3E-5	4.5E-6	0	0	0
56	2.7E-5	1.3E-5	1.5E-4	0	0	0
49	3.1E-5	1.8E-5	9.1E-6	5.9E-6	2.6E-6	0
42	4.4E-5	3.9E-5	0	0	0	0
41	5.3E-5	4.6E-5	1.1E-6	2.2E-6	1.6E-6	0
33	6.2E-5	6.1E-5	6.2E-5	4.5E-5	2.8E-5	2.2E-6
43	6.8E-5	6.7E-5	3.5E-5	2.9E-5	1.2E-5	9.7E-7
57	7.2E-5	2.6E-5	6.6E-6	4.3E-6	2.1E-6	0
30	7.9E-5	6.4E-5	2.8E-5	1.3E-5	2.0E-5	1.3E-5
51	8.0E-5	4.3E-5	1.6E-5	1.3E-5	1.3E-5	0
70	8.0E-5	6.8E-5	2.0E-5	1.0E-6	4.0E-5	2.0E-5
69	8.4E-5	2.5E-5	7.9E-6	8.8E-7	0	0
46	9.8E-5	5.8E-5	2.5E-5	2.6E-5	1.4E-5	2.7E-6
62	1.0E-4	9.3E-5	7.1E-5	3.6E-5	8.3E-6	1.2E-5
63	1.0E-4	1.0E-4	6.0E-5	2.8E-5	1.2E-5	5.2E-7
53	1.1E-4	6.0E-5	5.4E-5	5.2E-5	3.2E-5	9.2E-6
38	1.1E-4	6.9E-5	1.6E-5	1.1E-5	6.2E-7	0
40	1.4E-4	1.1E-4	5.2E-5	3.4E-5	2.9E-5	5.3E-7
52	1.5E-4	3.1E-5	1.6E-5	1.6E-5	1.1E-5	2.9E-7
71	1.6E-4	1.1E-4	5.8E-5	3.8E-5	2.4E-5	1.9E-5
55	1.7E-4	7.9E-5	6.0E-5	4.2E-5	2.9E-5	1.1E-5
59	1.7E-4	1.7E-4	1.5E-4	1.6E-4	1.6E-4	8.4E-5
39	2.0E-4	1.1E-4	3.4E-5	3.4E-5	1.3E-5	4.8E-6
37	2.0E-4	1.0E-4	5.7E-5	5.9E-5	2.6E-5	0
66	2.1E-4	2.3E-4	2.3E-4	1.1E-4	4.8E-5	3.7E-5
32	2.2E-4	2.5E-4	2.7E-4	2.8E-4	2.6E-4	9.5E-5
31	2.6E-4	2.3E-4	2.5E-4	2.0E-4	1.1E-4	8.0E-5
68	2.8E-4	1.1E-4	3.3E-5	3.0E-5	2.3E-5	2.3E-5
36	3.0E-4	1.3E-4	9.6E-5	1.0E-4	7.4E-5	6.9E-5
65	3.7E-4	3.7E-4	1.9E-4	1.4E-4	9.4E-5	7.5E-5
48	4.0E-4	4.3E-4	5.6E-4	4.0E-4	9.1E-4	5.1E-4
44	7.0E-4	5.9E-4	3.3E-4	2.9E-4	2.2E-4	2.1E-4
34	8.3E-4	8.7E-4	8.3E-4	7.9E-4	7.0E-4	3.6E-4
67	9.0E-4	1.0E-3	7.2E-4	6.2E-4	5.7E-4	5.1E-5
35	9.3E-4	1.0E-3	1.1E-3	1.0E-3	8.9E-4	6.2E-4

Table III (Continued)

OUTPUT ERROR RATE AS A FUNCTION OF B IN THE
TROPOSPHERIC CHANNEL

Run#	Input Error Rate	Output Error Rate				
		B=6	B=144	B=288	B=576	B=1200
47	1.1E-3	1.2E-3	1.2E-3	1.1E-3	1.0E-3	8.9E-4
50	1.2E-3	1.3E-3	1.2E-3	1.2E-3	1.5E-3	1.4E-3
58	2.2E-3	2.4E-3	2.4E-3	2.2E-3	1.9E-3	1.4E-3
45	2.4E-3	2.5E-3	4.7E-3	4.7E-3	4.7E-3	4.7E-3
54	4.0E-3	4.1E-3	4.1E-3	4.2E-3	3.8E-3	3.0E-3

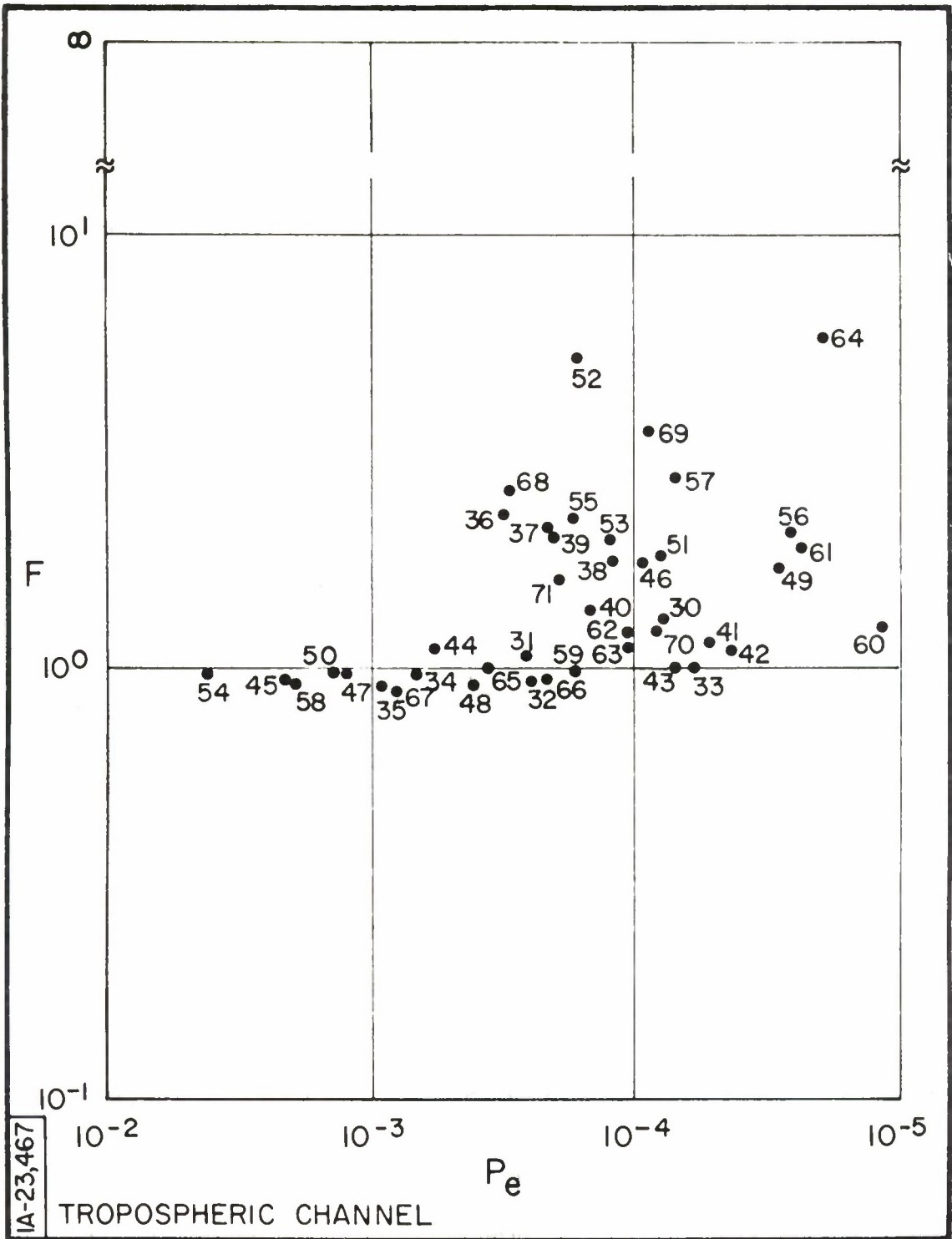

Figure 8 Simulation Test Results, $B = 6$
 Improvement Factor (F) Versus Channel Average Bit Error-Rate (P_e)

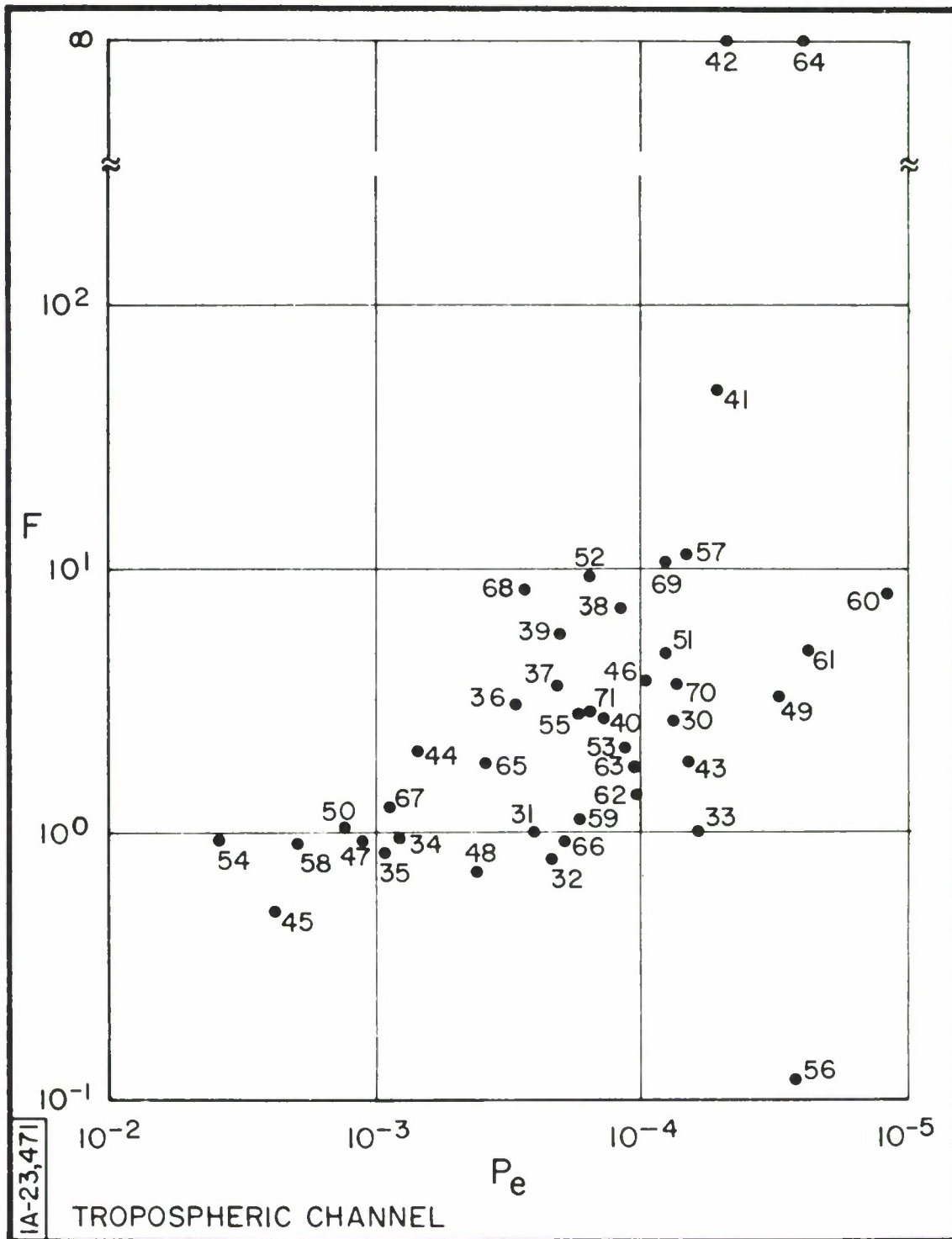

Figure 9 Simulation Test Results, $B = 144$
 Improvement Factor (F) Versus Channel Average Bit Error-Rate (P_e)

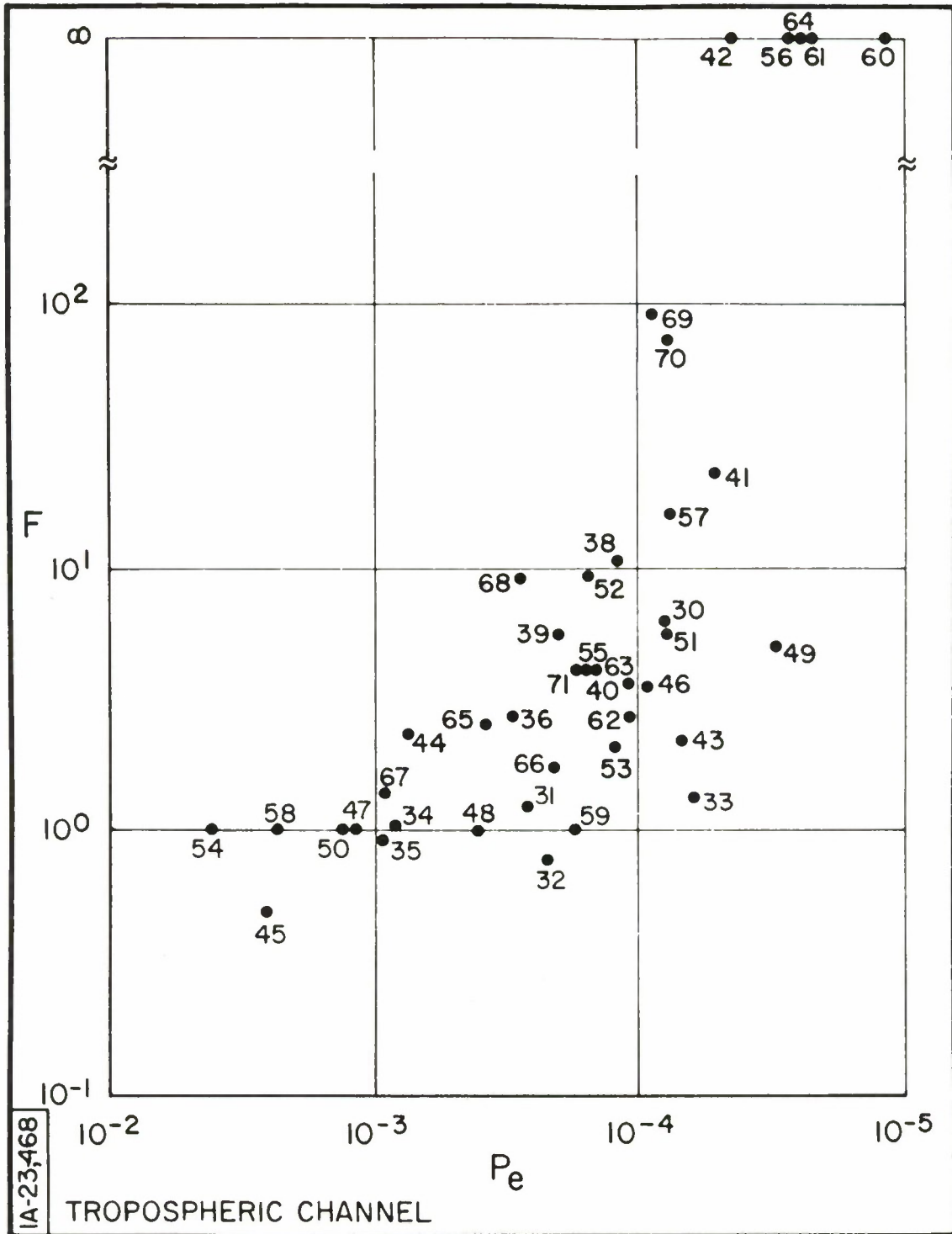

Figure 10 Simulation Test Results, $B = 288$
 Improvement Factor (F) Versus Channel Average Bit Error-Rate (P_e)

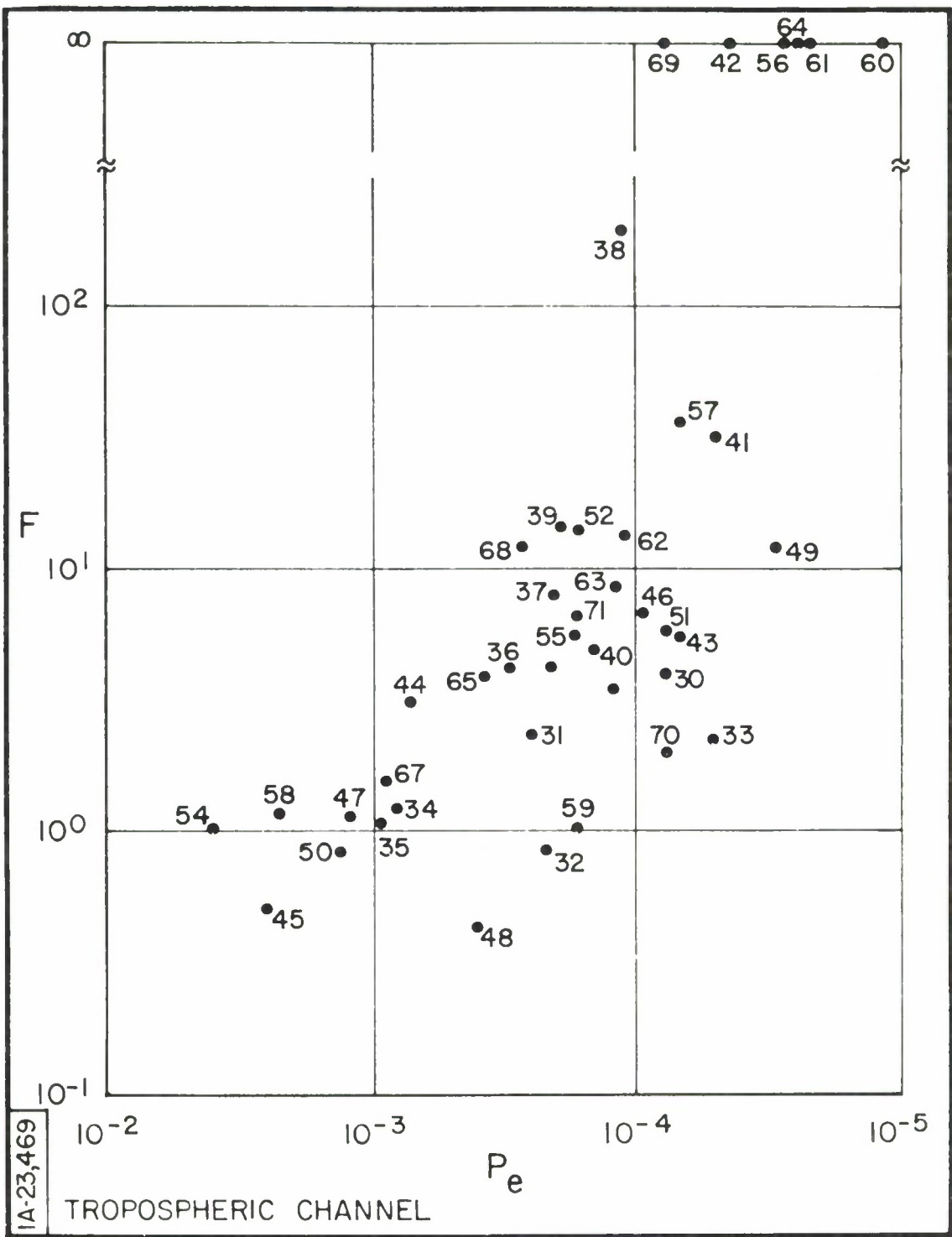

Figure 11 Simulation Test Results, B = 576
 Improvement Factor (F) Versus Channel Average Bit Error-Rate (P_e)

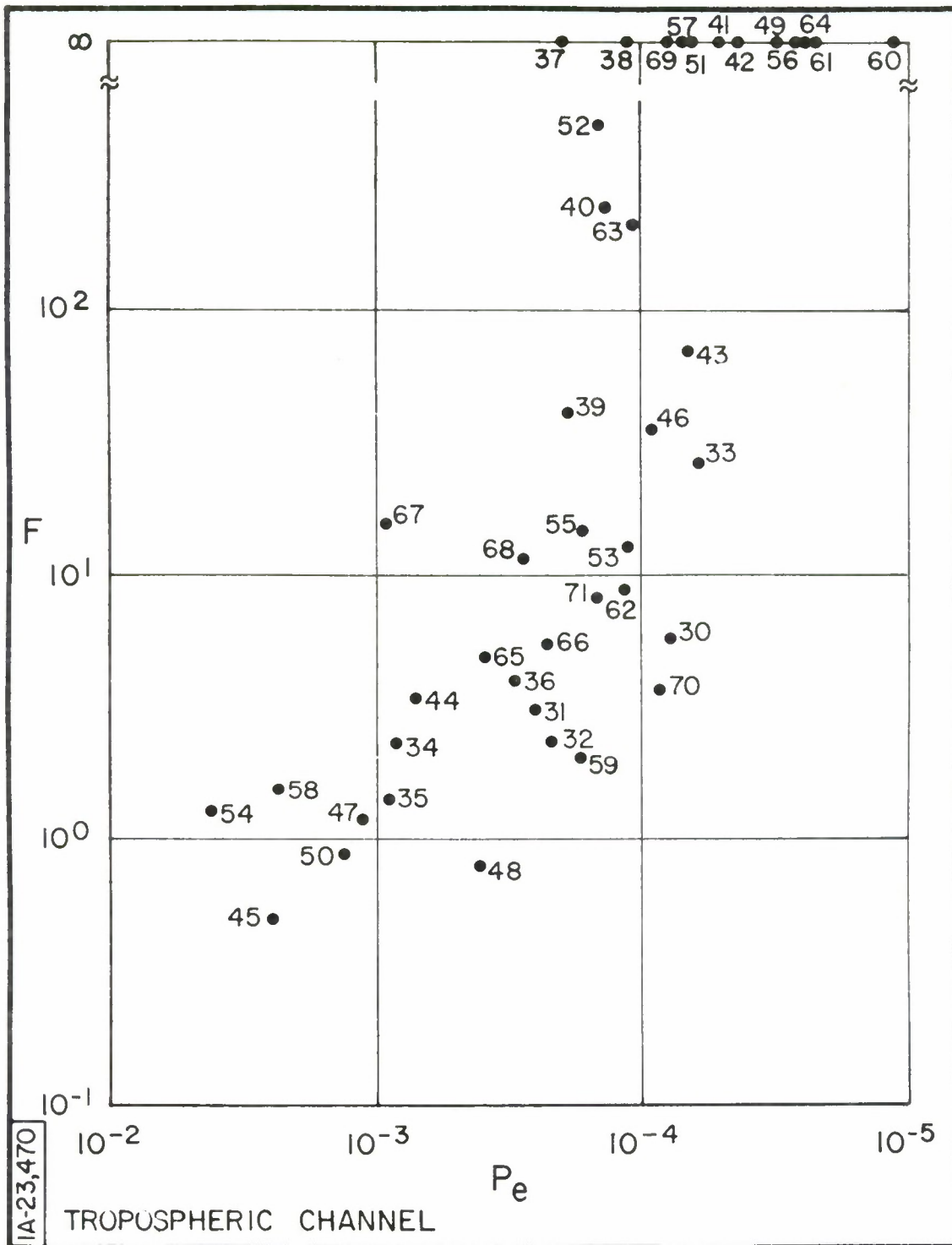

Figure 12 Simulation Test Results, B = 1200
Improvement Factor (F) Versus Channel Average Bit Error-Rate (P_e)

with no periodic errors, there was no need to specially adjust the values of B. It is obvious from the scatter diagrams that the value B=6 was insufficient for the long dense bursts in that improvement was less than one order of magnitude in error rate and on many runs $P_c > P_e$ (alternately $F < 1$). However, as B increases performance likewise increases, and when B reaches 1200 (3 sec delay) only three runs show $F < 1$ while the other runs have up to three orders of magnitude improvement with twelve runs completely corrected. It is obvious from the scatter diagram that this trend would continue if B were further increased.

Cumulative Performance Curves

A common method for presenting the performance of a communication system in which errors occur is to present the percent of channel data intervals for which the error rate is better than a particular value of error rate. This can be done for a coded system, and the curves can then be compared to the uncoded channel. In order to properly compare decoded to uncoded performance, the decoded interval length must be that length which contains the information portion of the corresponding channel data interval.

Thus,

$$\frac{\text{Decoded Channel Interval Length}}{\text{Uncoded Channel Interval Length}} = \text{Code Rate} \quad (4)$$

These results are presented in Figures 13 and 14 for the HF and Tropospheric data respectively.

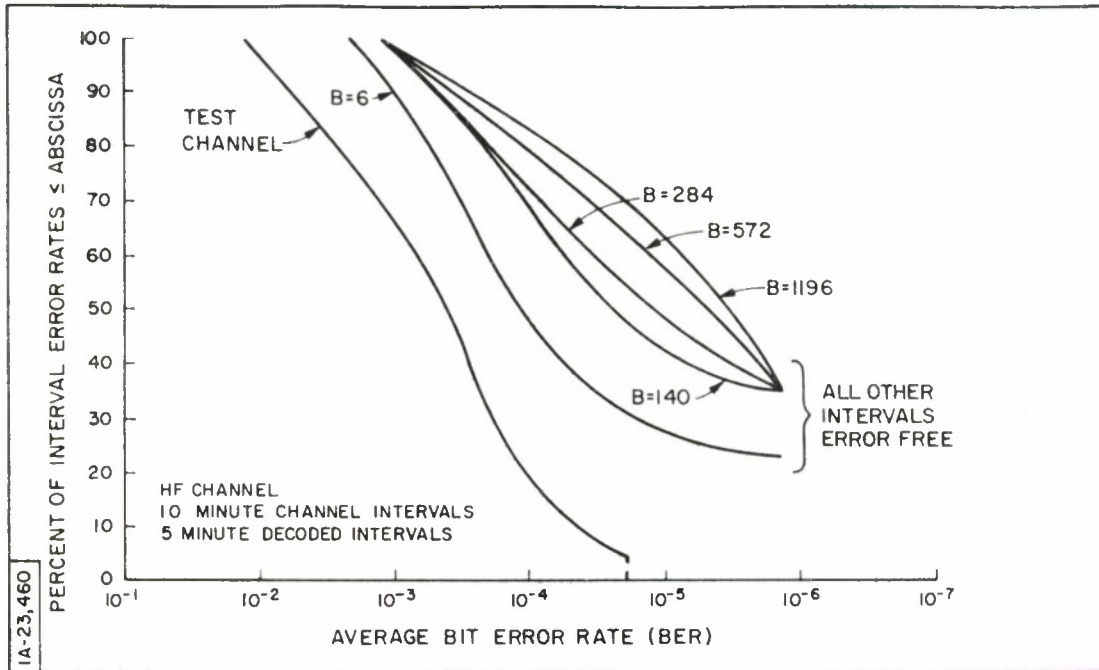

Figure 13 Cumulative Performance of Massey Code in HF Channel

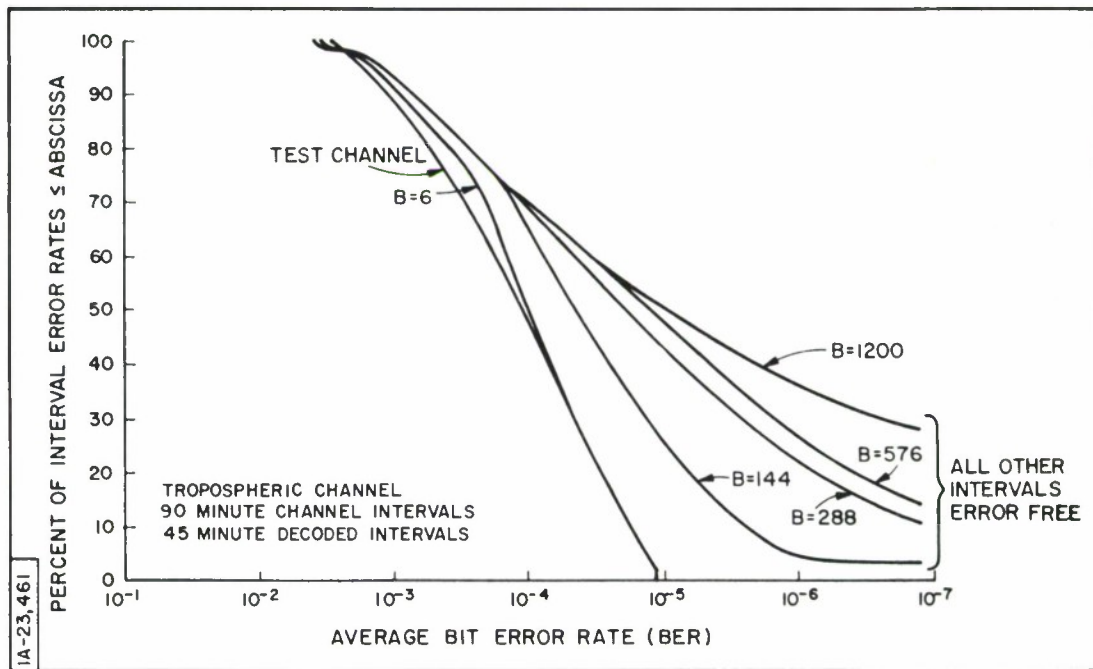

Figure 14 Cumulative Performance of Massey Code in Tropospheric Channel

SECTION III

CONVOLUTIONAL CODE ERROR PROPAGATION

It is known from the work of Massey that convolutional codes, when they fail, propagate errors. Further, at some stage in the operation of the decoder it is no longer necessary for channel errors to occur in order to have the propagation continue. This is called infinite propagation. An advantage of a computer simulation is that it is possible to tag the channel errors and follow them through the decoder. By doing this, it is possible to determine which errors were not corrected, what caused any additional output errors, and whether or not infinite propagation occurred. In Tables IV and V the percent of output errors that are uncorrected input errors for the HF data and tropospheric data respectively is presented. All of the remaining errors are generated errors with no direct counterpart in the channel error patterns. The generated errors were compared to the source error table, and it was found that in all cases the generated error was within a distance B of the source channel error. Thus, error generation occurred when a burst affected a coded unit of $3B+2$ information bits, and there was no spillover beyond the code length. An alternative way of stating this is that if errors occurred in three of the four coded information bits, an error was generated into the fourth bit which due to the diffusion of the code occurred B bits later in time. There was no infinite propagation observed. In fact a proof [1] exists that infinite propagation cannot occur for this particular code structure.

Table IV

% OF OUTPUT ERRORS THAT ARE UNCORRECTED INPUT ERRORS
HF DATA RUNS

Run Number	B=6	B=140	B=284	B=572	B=1196
333	--	--	--	--	--
324	--	--	--	--	--
291	--	--	--	--	--
318	50	--	--	--	--
321	--	--	--	--	--
345	77	44	75	67	60
354	54	33	75	33	100
248	60	--	--	--	--
258	53	52	54	54	42
315	52	57	75	85	57
342	54	60	63	46	57
264	53	64	59	64	54
309	64	59	63	67	40
261	55	56	55	58	56
312	53	56	58	58	64
249	58	53	55	56	53
339	48	52	51	52	52

Table V

% OF OUTPUT ERRORS THAT ARE UNCORRECTED INPUT ERRORS
TROPO DATA RUNS

Run Number	B=6	B-144	B=288	B=576	B=1200
60	64	75	--	--	--
64	69	--	--	--	--
61	66	63	--	--	--
56	66	50	--	--	--
49	59	62	71	57	--
42	67	--	--	--	--
41	79	50	75	100	--
33	72	68	71	78	67
43	77	67	65	64	100
57	65	51	78	54	--
30	65	67	52	55	59
51	60	65	72	65	--
70	71	62	80	51	57
69	69	58	75	--	--
46	64	58	66	62	78
62	59	57	57	67	55
63	65	60	61	59	67
53	62	62	65	62	53
38	73	51	57	50	--
40	67	58	54	53	50
52	53	54	62	63	100
71	57	54	55	55	55
55	60	55	65	67	37
59	78	78	73	68	59
39	72	61	65	63	69
37	67	61	60	58	--
66	76	63	61	64	66
32	74	70	70	66	66
31	69	63	60	52	60
68	71	60	52	60	66
36	64	58	54	59	58
65	66	63	62	63	60
48	74	77	74	68	59
44	60	58	60	58	57
34	67	59	59	56	60
67	75	65	65	58	57
35	73	63	66	66	60
47	62	60	64	63	56
50	74	77	77	70	64
58	67	63	64	63	64
45	84	82	79	74	65
54	67	64	61	62	60

SECTION IV

COMPARISON OF THE CONVOLUTIONAL TECHNIQUE TO CYCLIC CODING

Since there is a great deal of knowledge on the performance of the $(24, 12, 3)$ cyclic Golay code on the measured channels [2, 5] an idea of the significance of the results for the Massey code can be obtained by finding the performance of the Golay code on the test data for the same amount of delay used with the Massey code. The $(24, 12, 3)$ code can correct 3 random errors in 24 bits at code rate $1/2$. The code will be interleaved by coding together bits spaced m bits apart to obtain a code word. The total delay introduced by this technique is $24 m/1200$ seconds. If $m = 150$ then the delay is 3 seconds and a total interleaved code block contains $24 \times 150 = 3600$ bits. Generated errors can occur if there are more than three errors in a code word and will occur within that code word with no overflow from one code block to another. Thus, whatever generated errors do occur will be constructed in the same way that the generated errors of the Massey code, in fact, occurred. The performance of the $(24, 12, 3)$ code was found by simulation [6] for a delay of three seconds ($m = 150$). The performance of the code on the HF data was found previously [5] and will not be reproduced here. Comparison to the previously presented results indicates that the Massey diffuse convolutional code performs as well as the Golay code. The results found with the tropospheric data and presented in Table VI and Figure 15 are far different. For this channel the performance of

Table VI

PERFORMANCE OF GOLAY CODE ON
TROPOSPHERIC CHANNEL

Run #	Output BER	F	Run #	Output BER	F
60	2.14E-5	0.5	71	2.00E-5	8
64	3.00E-7	66.6	55	3.00E-7	566
61	3.00E-7	80	59	2.97E-4	0.5
56	1.40E-5	1.9	39	6.51E-4	.3
49	3.00E-7	103	37	1.08E-3	.18
42	3.00E-7	146	66	1.25E-4	1.6
41	2.15E-6	24.6	32	1.75E-4	1.2
33	1.94E-4	.31	31	8.50E-5	3.0
43	3.00E-4	226	68	3.00E-7	993
57	3.00E-7	240	36	7.00E-5	4.2
30	1.40E-5	5.6	65	1.50E-4	2.4
51	4.00E-5	2	48	5.86E-4	.68
70	1.15E-6	69.5	44	1.61E-4	4.3
69	5.00E-6	16.8	34	2.40E-5	34.5
46	2.15E-6	45.5	67	7.43E-4	1.2
62	4.00E-6	25	35	5.35E-4	1.7
63	1.20E-5	8.3	47	1.27E-3	.86
53	6.20E-7	177	50	2.39E-3	0.5
38	3.30E-5	3.3	58	3.00E-6	73.3
40	1.10E-5	12.7	45	4.95E-3	.48
52	1.15E-6	130	54	1.39E-3	2.8

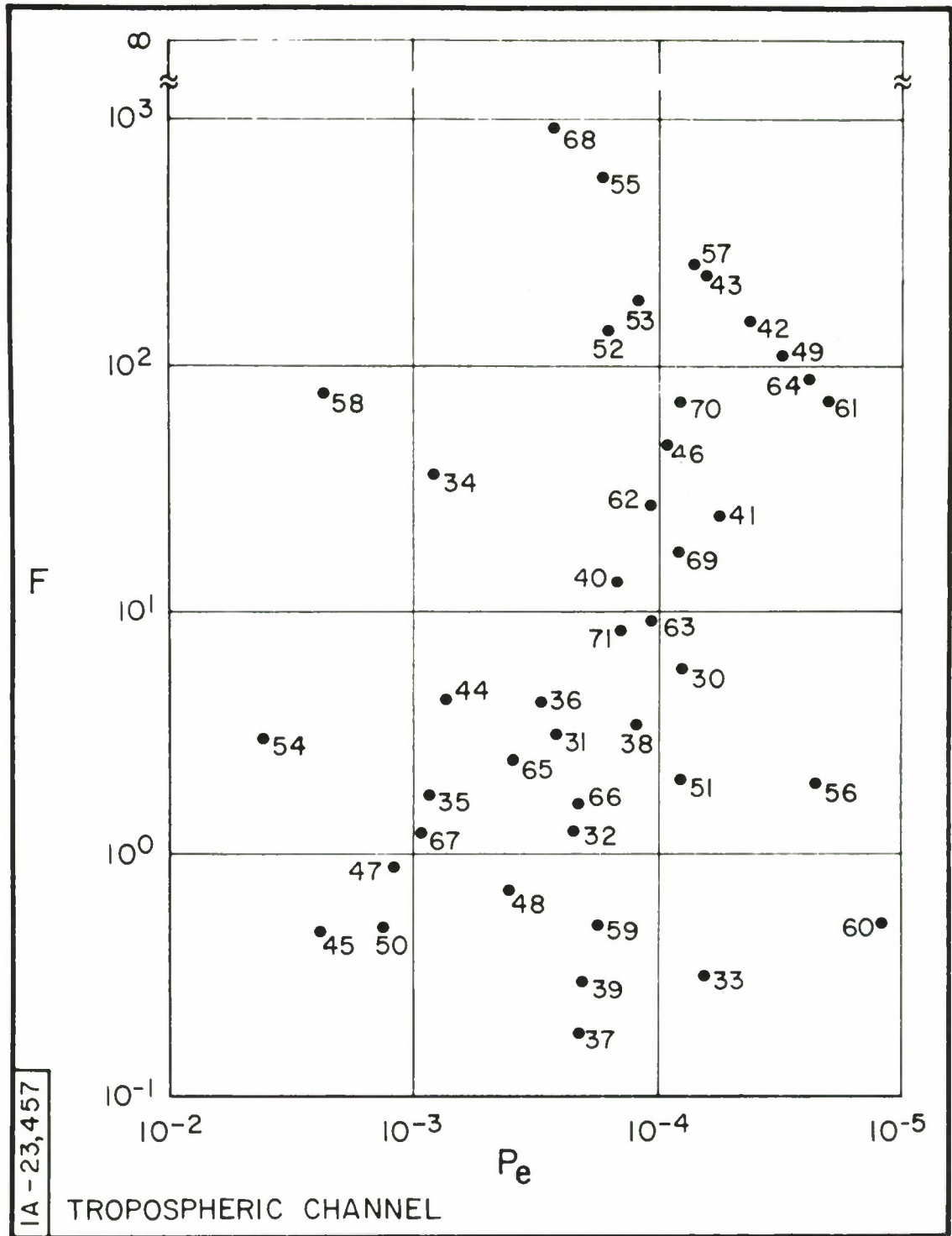

Figure 15 Simulation Test Results of Interleaved Cyclic Code with Three Seconds Delay
Improvement Factor (F) Versus Channel Average Bit Error-Rate (P_e)

the Massey diffuse convolutional code is substantially superior to that of the Golay. The Massey code achieved a zero output error rate on 12 of the 42 runs while the Golay code did not achieve a zero output error rate on any of the runs. The Massey code demonstrated overall error generation ($F < 1$) on 3 of the 42 runs while the Golay code did this on 9 of the 42 runs. In Figure 16 a comparison is made between the cumulative performance of the Massey diffuse code with $B = 1200$ (3 sec. delay) and the interleaved cyclic Golay code with the same delay.

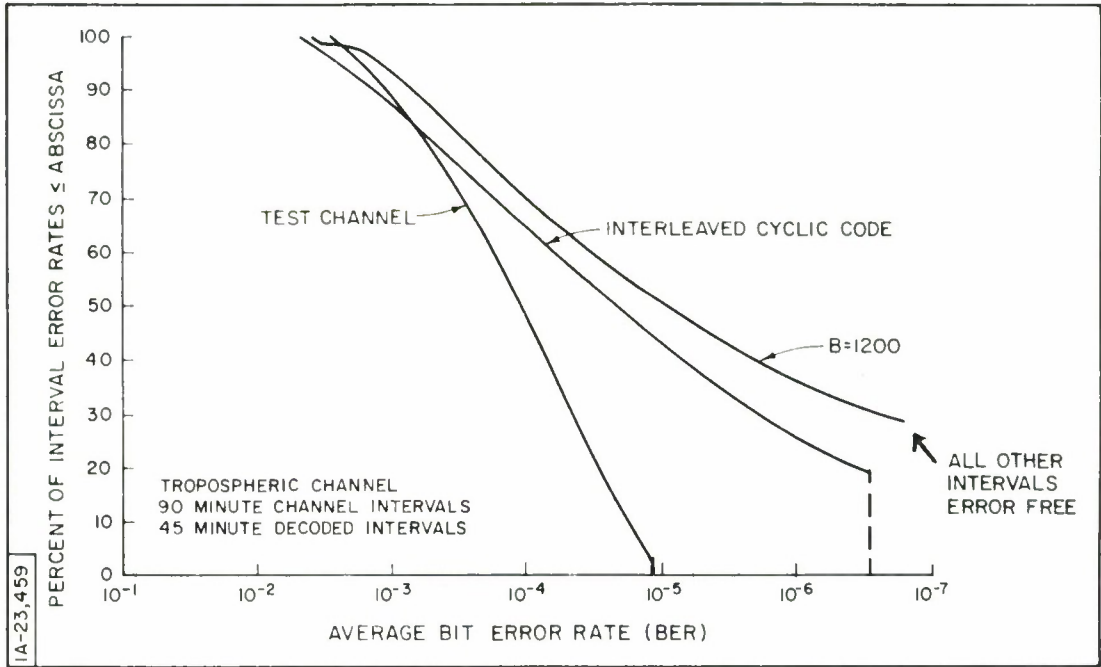

Figure 16 Comparative Performance of Massey and Cyclic Codes for Equal Delay

SECTION V
CONCLUSIONS

The objective of this paper has been to obtain the performance of a Massey diffuse convolutional code on actual measured HF and tropospheric error patterns. Based on the data, three general conclusions can be reached.

- 1) Improvement increases with delay with no upper bound on performance within the range of delays considered (Delay \leq 3 sec.).
- 2) Error generation occurs over a limited distance from the excessive burst of errors causing the generation.
- 3) a) On the HF data the Massey code performance is as good as that of the Golay code.
b) On the Tropospheric data the Massey code performance is superior to that of the Golay code.

REFERENCES

1. A. Kohlenberg and G.D. Forney Jr., "Convolutional Coding for Channels with Memory," to be published in IEEE Transactions on Information Theory, July 1968.
2. K. Brayer and O. Cardinale, "Evaluation of Error Correction Block Encoding for High Speed HF Data," IEEE Transactions on Communication Technology, June 1967,
3. K. Brayer, "Error Patterns Measured on Transequatorial HF Communication Links," MTP-46, The MITRE Corporation, Contract AF 19(628)-5165, Bedford, Mass., December 1966.
4. K. Brayer, "Error Statistics of a Multiple Link Data Transmission Circuit," MTP-40, The MITRE Corporation, Contract AF 19(628)-5165, Bedford, Mass., November 1966.
5. K. Brayer, "Design Considerations for Forward Error Control Equipment for HF Radio," MTR-362, The MITRE Corporation, ESD-TR-67-356, Contract AF 19(628)-5165, Bedford, Mass., February 1967.
6. T. Kasami, "A Decoding Procedure for Multiple-Error-Correcting Cyclic Codes," IEEE Transactions on Information Theory, April 1964.

DOCUMENT CONTROL DATA - R & D

(Security classification of title, body of abstract and indexing annotation must be entered when the overall report is classified)

1. ORIGINATING ACTIVITY (Corporate author) The MITRE Corporation Bedford, Massachusetts		2a. REPORT SECURITY CLASSIFICATION UNCLASSIFIED	
		2b. GROUP N/A	
3. REPORT TITLE THE PERFORMANCE OF A SIMULATED CONVOLUTIONAL DECODER ON MEASURED HF AND TROPOSPHERIC DATA CHANNELS			
4. DESCRIPTIVE NOTES (Type of report and inclusive dates) N/A			
5. AUTHOR(S) (First name, middle initial, last name) Kenneth Brayer			
6. REPORT DATE January 1968		7a. TOTAL NO. OF PAGES 41	7b. NO. OF REFS 6
8a. CONTRACT OR GRANT NO. AF 19(628)-5165		9a. ORIGINATOR'S REPORT NUMBER(S) ESD-TR-67-423	
b. PROJECT NO. 705B		9b. OTHER REPORT NO(S) (Any other numbers that may be assigned this report) MTR-528	
c.			
d.			
10. DISTRIBUTION STATEMENT This document has been approved for public release and sale; its distribution is unlimited.			
11. SUPPLEMENTARY NOTES N/A		12. SPONSORING MILITARY ACTIVITY Aerospace Instrumentation Program Office, Electronic Systems Division, L. G. Hanscom Field, Bedford, Mass.	
13. ABSTRACT A Massey diffuse convolutional decoder was simulated in the IBM 7030 computer and used to decode binary digital error patterns measured at 2400 bits/sec on an HF radio circuit and on a multiple link data circuit dominated by a tropospheric scatter path. It was found that the simulation performed at least as well as previous cyclic code simulations on HF radio and better than cyclic codes on the tropospheric path.			

14

KEY WORDS

LINK A		LINK B		LINK C	
ROLE	WT	ROLE	WT	ROLE	WT

SYSTEMS AND MECHANISMS
 Data Transmission Systems
 Multichannel Radio Systems
 Voice Communication (HF and Tropo) Systems

INFORMATION THEORY
 Cyclic Coding
 Convolutional Coding