

Contract No. Nonr 839 (38)

1031

AD666117

AN EXPERIMENTAL INVESTIGATION OF HYPERSONIC FLOW
AROUND A SLENDER CONE

by

Edward M. Schmidt and Robert J. Cresci

Distribution of this document is unlimited.



OCTOBER 1967

POLYTECHNIC INSTITUTE OF BROOKLYN

DEPARTMENT
of
AEROSPACE ENGINEERING
and
APPLIED MECHANICS

PIBAL REPORT NO. 1031

CLEARINGHOUSE

444

AN EXPERIMENTAL INVESTIGATION OF HYPERSONIC FLOW
AROUND A SLENDER CONE

by

Edward M. Schmidt and Robert J. Cresci

This research has been conducted under
Contract Nonr 839(38) for PROJECT DEFENDER
and was made possible by the support of the
Advanced Research Projects Agency under Order
No. 529 through the Office of Naval Research.

Reproduction in whole or in part is permitted for
any purpose of the United States Government.

Polytechnic Institute of Brooklyn
Department
of
Aerospace Engineering and Applied Mechanics
October 1967

PIBAL REPORT NO. 1031

AN EXPERIMENTAL INVESTIGATION OF HYPERSONIC FLOW
AROUND A SLENDER CONE ⁺

by

Edward M. Schmidt* and Robert J. Cresci**

Polytechnic Institute of Brooklyn, Graduate Center

Farmingdale, New York

ABSTRACT

This paper presents the results of an experimental survey of the flow field around a sharp, 10° half angle cone. Tests were conducted at a free stream Mach number of 7.7 for a range of free stream Reynolds numbers of 0.11×10^6 to 1.71×10^6 per foot. Surface heat transfer data indicates that the cone boundary layer varies from laminar to fully developed turbulent over this Reynolds number range. The base pressure variation was also obtained throughout this range of Reynolds numbers; from this, the interrelation between the surface boundary layer properties and the base pressure is discussed. A series of tests were conducted in the near wake region at two different values of free stream Reynolds number, i. e., 0.33×10^6 and 1.65×10^6 per foot, corresponding to a completely laminar and fully developed turbulent surface boundary layer at the cone shoulder, respectively. The relationship between boundary layer properties and near wake properties is studied.

* This research was supported under Contract Nonr 839(38) for PROJECT DEFENDER, and the Advanced Research Projects Agency under Order No. 529 through the Office of Naval Research.

* Research Associate

** Professor of Aerospace Engineering

..

TABLE OF CCNTENTS

<u>Section</u>		<u>Page</u>
I	Introduction	1
II	Model Design and Test Procedure	2
III	Discussion of Results	4
IV	Conclusions	9
V	References	11

BLANK PAGE

LIST OF ILLUSTRATIONS

<u>Figure</u>		<u>Page</u>
1	Schematic of Test Configuration	14
2	Wake Survey Rakes	15
3	Surface Heat Transfer Vs. Reynolds Number	
	(a) $\bar{s}=1.96$	16
	(b) $\bar{s}=2.80$	17
4	Location of Boundary Layer Transition	18
5	Base Pressure Vs. Reynolds Number	19
6	Pitot Pressure Profiles	
	(a) $\bar{x}=1.0$	20
	(b) $\bar{x}=1.50$	20
	(c) $\bar{x}=2.10$	21
	(d) $\bar{x}=2.50$	21
	(e) $\bar{x}=3.30$	22
	(f) $\bar{x}=4.75$	22
7	Static Pressure Profiles	
	(a) $\bar{x}=1.0$	23
	(b) $\bar{x}=1.50$	23
	(c) $\bar{x}=2.10$	24
	(d) $\bar{x}=2.50$	24
	(e) $\bar{x}=3.30$	25
	(f) $\bar{x}=4.75$	25

LIST OF ILLUSTRATIONS (Cont' d.)

<u>Figure</u>		<u>Page</u>
8	Total Temperature Profiles	
	(a) $\bar{x}=1.0$	26
	(b) $\bar{x}=1.50$	26
	(c) $\bar{x}=2.10$	27
	(d) $\bar{x}=2.50$	27
	(e) $\bar{x}=3.0$	28
	(f) $\bar{x}=4.75$	28
9	Centerline Distribution of Static Pressure	29
10	Centerline Distribution of Stagnation Temperature	30
11	Centerline Distribution of Mach Number	31
12	Centerline Distribution of Stagnation Pressure	32
13	Centerline Distribution of Static Temperature	33
14	Trailing Shock Configurations	34

LIST OF SYMBOLS

c_p		Specific heat at constant pressure
D		Cone base diameter (8.0 inches)
h		Enthalpy
k		Coefficient of thermal conductivity
M		Mach number
N_{Nu}	=	$q_w c_p / (p_\infty D / k_\infty (h_{s_\infty} - h_w))$ - Nusselt number
N_{Re_θ}	=	$\rho_\infty V_\infty \theta / \mu_\infty$ - Reynolds number based on momentum thickness
p		Pressure
p_b		Base pressure
p_t		Pitot pressure
q		Heat transfer rate
$Re_{\infty D}$	=	$\rho_\infty V_\infty D / \mu_\infty$ - Reynolds number
s		Cone surface coordinate
T		Temperature
V		Velocity
x		Coordinate in free stream direction measured from cone base
y		Radial coordinate measured from centerline
$(\bar{\quad})$		Coordinate normalized with respect to base diameter
δ		Momentum thickness
θ_c		Cone half angle
ρ		Mass density
μ		Coefficient of viscosity

Subscripts

s	Stagnation conditions
w	Conditions evaluated at cone surface
∞	Free stream conditions
1	Local conditions
2	Conditions behind a normal shock

I. INTRODUCTION

A vehicle reentering the earth's atmosphere leaves behind it a trail of hot gases. This wake can give an indication of the vehicle's shape, weight and size through correct interpretation of the observable wake properties. To make such an interpretation a basic knowledge of the fluid physics of the wake must be obtained.

In the past, considerable research has been devoted to the study of the far wake. This region is readily amenable to both analytic and experimental investigation and as such, a large amount of information on this region is available in the open literature. However, the starting point for any far wake analysis must be obtained through knowledge of the near wake properties. The near wake is a region presenting a difficult challenge to the fluid mechanician. For a bluff-based body with its regions of separated flow, recirculating flow, recompression zones, etc., the problem it presents is especially complicated, and a unified solution continuously valid throughout the flow field is still forthcoming. Many researchers have devoted serious study to this region both analytically, Ref. 1-5, and experimentally, Ref. 6-13. A review of most of the available literature concerned with wake studies is contained in Ref. 14. The present report presents an experimental study of the near wake region and some effects of the free stream Reynolds number variation on its properties. Through comparison with data obtained by other sources, the effect of Mach number variation is also examined. The model used is a sharp 10° half angle cone with a base diameter of 8 in. It is supported during the tests by six braided steel cables of $1/32$ in. cross-sectional diameter. This method of support has raised the question of interference with the base flow field; however, various researchers have studied this problem, Ref. 6-9 and 13, and have arrived at somewhat different conclusions. It is now generally accepted that for ratios of wire to base diameter less than approximately 0.010 there is no discernible wire interference effect. The present wire to base diameter ratio is 0.0039 which is well within this limit.

Tests were performed at a Mach number of 7.7 in the PIBAL Hypersonic Blowdown Facility with air as the test gas. The range of test Reynolds numbers available allowed the surface boundary layer to be varied from completely laminar to fully turbulent at a point near the cone shoulder. To determine the properties of the local surface boundary layer under this variation, a surface heat transfer survey was taken. The base pressure variation also was obtained for this range of Reynolds numbers. For the near wake survey, two Reynolds numbers were selected, one corresponding to a laminar boundary layer at the cone shoulder and the other to a fully turbulent boundary layer. This survey consisted of taking radial profiles of static pressure, pitot pressure, and stagnation temperature at selected axial locations. From these measured flow properties, all other desired flow properties can be obtained.

Due to the limitations on stagnation temperatures available in the facility it was possible to simulate the free stream Mach number and Reynolds numbers of interest but not the total enthalpies resulting in the free flight condition. Therefore, this survey is purely fluid mechanical in nature and contains no chemical kinetic effects.

II. MODEL DESIGN AND TEST PROCEDURE

The model shown in Fig. 1, is a 10° half angle cone fabricated out of stainless steel of 0.05 in. thickness with a flat base plate inserted. In order to prevent any leakage of air through the base plate-cone junction, thorough precautions are taken to insure an effective pressure seal. To determine the nature of the surface boundary layer, the cone surface is instrumented with thermocouples at selected locations along a generator. These thermocouples consist of fine thermocouple wires spot welded to the inside of the model skin. The local heat transfer rate may then be determined using the thin skin technique (cf. Ref. 6). The basic assumptions of this technique are that no heat is transferred along the surface of the cone and that the

inner surface is adiabatic. For these surface heat transfer tests, the cone is sting supported using a specially designed base mounting which facilitates removal of instrumentation wires. The tunnel stagnation pressure is then varied between tests (but held constant during each test) such that a wide range of free stream Reynolds numbers is obtained.

To obtain near wake and base pressure measurements, the model is wire supported. This system of support consists of using six $1/32$ in. braided steel cables to fix the model in position. Three cables secure the front and three cables are affixed to the rear just slightly aft of the model center of gravity. In this manner, the nearest wires are approximately 250 wire diameters from the base and in this distance their effect on the flow field is largely dissipated before reaching the cone shoulder. The base pressure survey is taken using a Hastings type DV 13 gauge mounted at the center of the model base. All instrumentation leads for this gauge are taken out of the model along the support wires and are of a diameter less than the support wire diameter thereby insuring minimal interference with the flow field. These tests are run over the same Reynolds number range as the surface heat transfer tests.

Using the surface heat transfer results as a guide to select the two desired flow Reynolds numbers, the near wake survey is obtained using the wire supported model. Three identical rakes consisting of ten probes spaced $3/4$ in. apart are used, cf. Fig. 2. The total head rake consists of standard pitot tubes with blunt leading edges connected to Statham 0.5, 2.5, and 15 psia transducers. The static probes consist of tubes with six static holes drilled around their periphery at a distance of 15 tube diameters from the tip; slender (5°) cones are installed at the tips of the probes to facilitate the decay of local static pressure on the probe surface to that of the local free stream. The static pressure is measured using Hastings DV-13 gauges.

In the Mach number-Reynolds number range considered, viscous-inviscid interaction effects are found to be negligible on the static pressure probe's surface. The total temperature rake utilized is the total pressure rake with bare wire thermocouples and supporting tube inserts added. The junction is formed midway between the supporting tubes using 40 gauge wire. The wire length is such as to insure large wire length to diameter ratio (approximately 300) and thereby provide for rapid response to the free stream equilibrium temperature. From total head and static pressure data, the Mach number is obtained and the local value of the stagnation pressure is computed. Correspondingly, from the Mach number and stagnation temperature, the local value of static temperature is obtained.

The nominal stagnation temperature is 1700° R, although this varied $\pm 100^{\circ}$ for the tunnel pressures obtained. The range in test Reynolds numbers results from varying the tunnel stagnation pressure between 30 psia and 500 psia. The test duration is such that the model skin temperature is essentially constant in comparison to the free stream stagnation temperature; therefore, the wall to stagnation temperature ratio is practically constant at 0.30 to 0.33. From the surface heat transfer data, two test pressures were selected for which the near wake tests were run; these correspond to free stream Reynolds numbers of 0.33×10^6 and 1.65×10^6 per foot. The surface boundary layer at the shoulder under these conditions was completely laminar and fully turbulent, respectively.

III. DISCUSSION OF RESULTS

The results of the surface heat transfer study are shown in Figs. 3 and 4. Typical plots of the Nusselt number vs. Reynolds number are presented in Figs. 3a and 3b for different locations along a generator of the cone. Also included are the theoretical predictions of Eckert^{15, 16} for both laminar and turbulent flow.

From these plots one can readily obtain the Reynolds number at which transition occurs and also the Reynolds number for which the flow is fully turbulent. If the transition Reynolds number is converted to one that is based on momentum thickness rather than surface distance, the value of this parameter is seen (cf. Fig. 4) to be relatively constant at approximately 600. The gauge located furthest downstream ($\bar{s} = 2.80$) is seen to indicate the existence of turbulent flow at the highest test Reynolds number ($Re_{\infty D} = 1.1 \times 10^5$); the shoulder is slightly downstream of this point ($\bar{s}_b = 2.85$). Thus the surface boundary layer for the high Reynolds number wake tests is fully turbulent. For this condition the boundary layer is transitional over roughly 40% of the conical surface. Wake surveys were also obtained at a test Reynolds number of 0.22×10^5 ; this corresponds to a surface boundary layer which is completely laminar.

The base pressures were obtained at the model centerline over the same range of Reynolds numbers as the surface heat transfer tests; these data are shown in Fig. 5 along with some additional data for different Mach numbers obtained from references 6-22. The free stream Reynolds number for which transition occurs at the cone shoulder location is indicated therein ($Re_{\infty D} \approx 0.6 \times 10^5$). It is observed that the base pressure starts to decrease quite rapidly at a value of the test Reynolds number which is somewhat higher than this ($Re_{\infty D} \approx 1.0 \times 10^5$); this gives some indication of the behavior of the boundary layer after it separates from the surface and expands into the low pressure base region. The observed variation of base pressure with Reynolds number has been described previously (cf., Refs. 17 and 18) and may be summarized as follows. When the surface boundary layer is turbulent, more momentum is entrained by the boundary layer from the inviscid flow field due to turbulent mixing. Since the boundary layer at the cone shoulder provides the initial conditions for the separated shear layer, the additional momentum in the turbulent boundary layer is fed into the shear layer which is better able to withstand the adverse pressure gradient it experiences in traversing the dis-

tance from the shoulder to the rear stagnation point. Thus, the flow adjusts itself to a larger initial expansion angle yielding a lower static (base) pressure after the expansion and, coincidentally, a larger adverse pressure gradient between the expanded flow and the rear stagnation point. Therefore, if the layer being shed is turbulent in nature, it can sustain a larger gradient in comparison to an initially laminar flow. The greater expansion and higher velocities of the turbulent shear layer, therefore, produce a lower base pressure than that occurring at lower Reynolds numbers. It has been suggested that the region of rapid decrease in base pressure corresponds to a transitional flow in the separated shear layer which then moves upstream (with increasing free stream Reynolds number) until it reaches the surface and causes the surface boundary layer to become transitional. The present base pressure data, however, yields a Reynolds number of roughly 1.0×10^6 at which the base pressure drops off sharply, while the surface boundary layer first becomes transitional at a Reynolds number of 0.6×10^6 . This indicates that even for a Reynolds number for which the surface boundary layer is transitional, the separated shear layer may be laminar; this can occur as the boundary layer expands around the corner into the base region. When the base region first exhibits the effects of a transitional shear layer (as indicated by the sharp decrease in base pressure), the surface boundary layer is transitional over roughly one-third of the cone surface and, in fact, is almost fully turbulent at the shoulder. In order to relate the near wake properties directly to the surface boundary layer behavior, therefore, it is important to determine the detailed behavior of transition in the shear layer. This can be done quite readily with a hot wire anemometer but was not performed in the present study.

The near wake survey consisted of taking profiles of pitot pressure, static pressure, and stagnation temperature and using these data to obtain the local

flow properties. Profiles of total pressure are presented in Figs. 6a through 6f; clearly visible in this data is the location of the trailing shock wave. Due to the bow shock reflecting from the walls of the tunnel, profiles which were taken further downstream than 5 base diameters are of questionable value; however, the centerline values are not affected until approximately 7 base diameters downstream. In Figs. 7a through 7f, the results of the static pressure survey are plotted. Due to the construction of these probes and the effect of the local shock interference with the probe boundary layer, it is expected that the location of the trailing shock will not be as well-defined by this data. Examination of the profiles shows that this is in fact so. It is seen that in the viscous core of the wake, i. e., within the trailing shock boundaries, the static pressure is reasonably uniform downstream of the neck region.

The stagnation temperature profiles are shown in Figs. 8a through 8f. The major difference in the high and low Reynolds number tests seems to occur in the viscous core region; the outer flow is practically identical for both sets of data (again, this is not true at $\bar{x}=1.0$ since this is close to the sonic region where small changes can effect the "inviscid" flow considerably).

The static pressure distribution along the centerline is presented in Fig. 9. It is seen that with the exception of the recirculation region the static pressures in the low and high Reynolds number tests are roughly the same. This indicates that the local pressure appears to be influenced more by the outer "inviscid" flow than by the nature of the viscous core. In fact, comparison with other data at Mach 5⁹ and Mach 16²³ shows an insensitivity to free stream Mach number.

Fig. 10 shows the centerline variation of stagnation temperature for both laminar and turbulent flow on the cone surface. Also included for comparison is the data of Refs. 9 and 12. The more rapid approach to the free stream total temperature is evident for the turbulent case in comparison to the laminar condition.

From the measured data presented in the previous figures, one can compute the local Mach number, stagnation pressure, and static temperature. This has been done along the centerline and is shown in Figs. 11 through 13, respectively.

The location of the rear stagnation point can be estimated from the Mach number distribution by extrapolation. From this plot it is seen that the lower Reynolds number tests have a rear stagnation point at approximately one base diameter downstream of the base, while the high Reynolds number tests have a stagnation point located between 0.75 and 0.85 of a base diameter downstream. For both test conditions, the flow very quickly attains local sonic velocity after the rear stagnation point. Due to the greater expansion at the shoulder experienced by the higher Reynolds number flow, the velocity of the outer stream will be higher; therefore, it is to be expected that this flow will be accelerated faster than the lower Reynolds number flow. This will occur even without considering the more rapid mixing associated with the locally turbulent flow in comparison to the laminar condition. Further downstream it is seen that the low and high Reynolds number data begin to approach each other. The location of transition in the near wake can be estimated, for example, by applying the empirical correlations presented in references 24 and 25 while the location of fully turbulent flow can be estimated from reference 26. For the laminar flow condition, these correlations yield a transitional location of 3.5 and 6 base diameters downstream of the model, respectively, while the flow is turbulent at a distance of 8 base diameters. The centerline variation of total temperature and Mach number show that beyond 4 diameters downstream of the base the data for both Reynolds numbers rapidly approach each other, indicating the probability of the lower Reynolds number flow becoming transitional. Unfortunately, no data was able to be obtained beyond 8 diameters to ascertain whether the initially laminar and initially turbulent flows are identical when they both become fully turbulent, although extrapolation of the data appears to imply this result.

Fig. 12 presents the ratio of local stagnation pressure to free stream stagnation pressure along the centerline of the flow. Initially, there is a factor of three or more between the laminar and turbulent data; however, at a downstream distance of six base diameters, this ratio has decreased to 1.5. Again, this is indicative of the more rapid mixing occurring as the initially laminar wake becomes transitional.

Fig. 13 shows the centerline distribution of static temperature obtained from the centerline values of Mach number and stagnation temperature. The static temperature reaches a maximum value in the vicinity of the rear stagnation point and then slowly decays to the free stream value downstream. It is noted, that whereas the static pressure has recovered to the free stream value at $\bar{x} \approx 6.0$, the local static temperature is still more than twice the free stream static temperature at this point. The data of Ref. 12 also indicates failure to recover as far downstream as 8 base diameters, while the static pressure has approached its free stream value much more rapidly.

Fig. 14 shows the trailing shock shape as determined from the pitot pressure profiles; also shown is the shape of the bow shock and its approximate reflection from the tunnel wall. The extent of validity of both the centerline data and the wake survey profiles can be estimated from this figure. It also appears that within the accuracy of determination of the trailing shock configurations, there is very little difference between the shock shapes for the laminar and turbulent cases.

IV. CONCLUSIONS

The surface boundary layer has an important role in determining the near wake characteristics. As transition occurs along the surface, the rear stagnation point moves closer to the base and due to turbulent mixing in the free shear

layer, more momentum is entrained in the viscous core from the local inviscid flow. This causes a general shift of the near wake characteristics in the upstream direction. Once transition occurs in an initially laminar near wake, the effects of the initial surface boundary layer become less important and the local flow conditions approach those characteristic of an initially turbulent layer.

The base pressure and the pressure distribution in the recirculation region are strongly related to the surface boundary layer. Transition on the body is accompanied by a marked decrease in base pressure and a smaller recirculation region, however, this effect does not occur immediately but only after the transition point has moved upstream a considerable distance along the body surface. Hot wire studies relating boundary layer transition to transition location in the free stream layer are extremely important in this regard.

It is also seen that once transition occurs in the near wake, both low and high Reynolds number tests show similar recovery ratios of local properties to their free stream values. Although the static pressure recovers within 6 base diameters in both cases, the static temperature and stagnation pressure recovery is much more gradual and does not recover for a considerable distance downstream.

V. REFERENCES

1. Golick, R. J., Webb, W. H., and Lees, L., Further Results of Viscous Interaction Theory for the Laminar Supersonic Near Wake, AIAA Paper No. 67-61, January 1967.
2. Webb, W. H., Golick, R. J., Vogenitz, F. W. and Lees, L., A Multimoment Integral Theory for the Laminar Supersonic Near Wake, Proceedings of the 1965 Heat Transfer and Fluid Mechanics Institute, pp. 168-189
3. Weiss, R. F., A New Theoretical Solution of the Laminar, Hypersonic Near Wake, AIAA Paper No. 67-63, January 1967.
4. Weiss, R. F. and Weinbaum, S., Hypersonic Boundary Layer Separation and the Base Flow Problem, AVCO RR 221, July 1965.
5. Baum, E. and Denison, M. R., Interacting Supersonic Laminar Wake Calculations by a Finite Difference Method, AIAA Journal Vol. 5, No. 7, July 1967, pp. 1224-1230.
6. Zakkay, V. and Cresci, R. J., An Experimental Investigation of the Near Wake of a Slender Cone at $M_{\infty}=8$ and 12, AIAA Journal, Vol. 4, No. 1, January 1966, pp. 41-46.
7. Martellucci, A., Trucco, H., and Agnone, A., Measurements of the Turbulent Near Wake of a Cone at Mach 6, AIAA Journal, Vol. 4, No. 3, March 1966 pp. 385-391
8. Muntz, E. P. and Softley, E. J., A Study of Laminar Near Wakes, AIAA Journal, Vol. 4, No. 6, June 1966, pp. 961-968
9. Todisco, A. and Pallone, A., Measurements in Laminar and Turbulent Near Wakes, AIAA paper No. 67-30, January 1967.
10. Demetriades, A. and Bauer, A., Supersonic Wind Tunnel Experiments with Axisymmetric Wakes, AIAA Paper 66-453, June 1966.

11. Martellucci, A., and Schlesinger, A. J., Measurements in the Near Wake of a Cone at Mach 12, GASL TR 582, March 1966.
12. Ragsdale, W. C., and Darling, J. A., An Experimental Study of the Turbulent Wake Behind a Cone at $M = 5$, Proceedings of the 1966 Heat Transfer and Fluid Mechanics Institute, pp. 198-209.
13. Dayman, B., Support Interference Effects on the Supersonic Wake, AIAA Journal, Vol. 1, No. 8, August 1963, pp. 1921-1923.
14. Lykoudis, P. S., A Review of Hypersonic Wake Studies, AIAA Journal, Vol. 4, No. 4, April 1966, pp. 577-590.
15. Eckert, E. R. G., Engineering Relations for Friction and Heat Transfer To Surfaces in High Velocity Flow, Journal of the Aeronautical Sciences, Vol. 22, No. 8, August 1955, pp. 585-587.
16. Cresci, R. J., MacKenzie, D. A., and Libby, P. A., An Investigation of Laminar, Transitional, and Turbulent Heat Transfer on Blunt Nosed Bodies in Hypersonic Flow, Journal of the Aerospace Sciences, Vol. 27, No. 6, June 1960, pp. 401-414.
17. Bogdonoff, S., A Preliminary Study of Reynolds Number Effects on Base Pressure at $M = 2.95$, Journal of the Aeronautical Sciences, Vol. 19, No. 3, March 1952, pp. 201-206.
18. Kavanau, L., Base Pressure Studies in Rarefied Supersonic Flows, Journal of the Aeronautical Sciences, Vol. 23, No. 3, March 1956, pp. 193-230.
19. Zarin, N., Base Pressure Measurements on Sharp and Blunt 9° Cones at Mach Numbers from 3.50 to 9.20, AIAA Journal, Vol. 4, No. 4, April 1966, pp. 743-745.
20. Ward, L., and Choate, R., A Model Drop Technique for Free-Flight Measurements in Hypersonic Wind Tunnels Using Telemetry, AEDC-TR-66-77, May 1966.

21. Softley, E. J., and Graber, B. C., An Experimental Study of the Pressure and Heat Transfer on the Base of Cones in Hypersonic Flow, AGARD Conference Proceedings No. 19, May 1967.
22. Martellucci, A., and Ranlet, J., Experimental Study of Near Wakes, General Applied Science Laboratories, Inc., Technical Progress Report, October 1966.
23. Murman, E. M., Peterson, C. W., and Bogdonoff, S. M., Diagnostic Studies of Laminar Hypersonic Cone Wakes, AGARD Conference Proceedings No. 19, May 1967.
24. Pallone, A. J., Erdos, J. I., Eckerman, J. and McKay, W., Hypersonic Laminar Wakes and Transition Studies, AVCO RAD-TM-63-33, June 1963.
25. Zeiberg, S. L., Transition Correlations for Hypersonic Wakes, AIAA Journal, Vol. 2, No. 3, March 1964, pp. 564-565.
26. Waldbusser, E., Shape Effects on Hypersonic Slender Body Wake Geometry and Transition Effects, GE 65 SD 5285, December 1966.

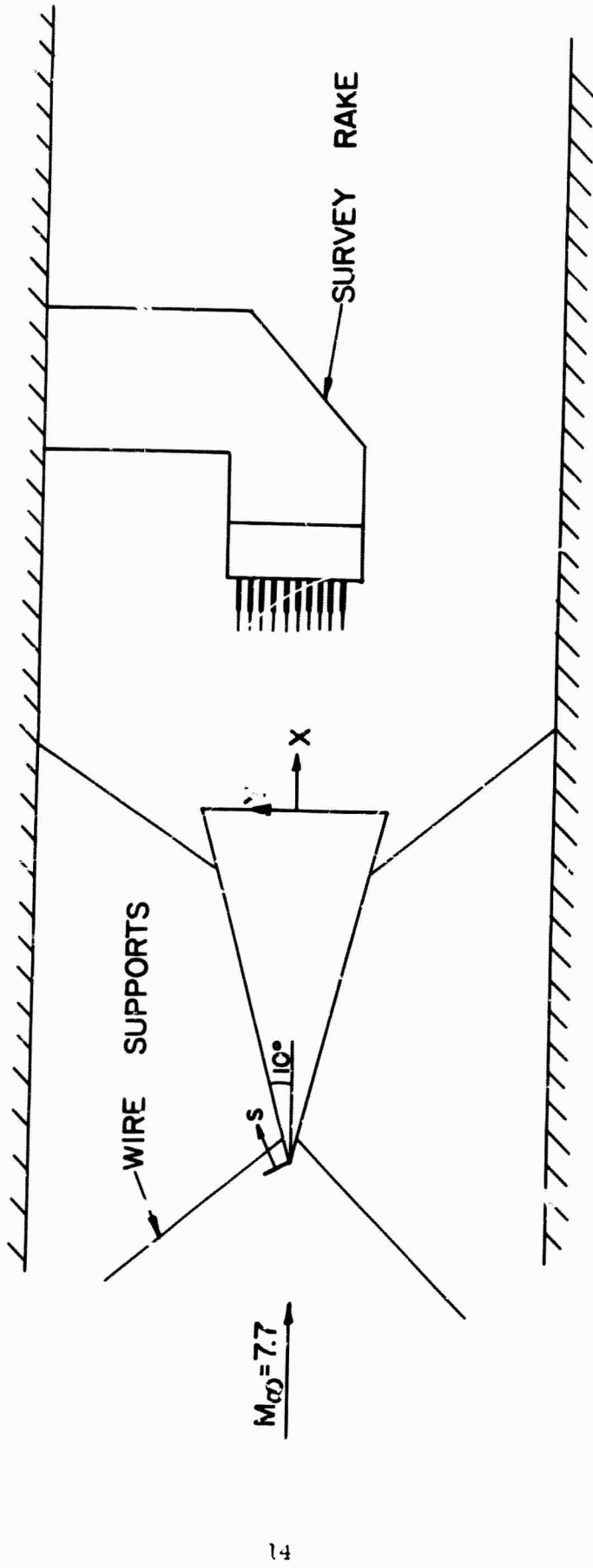

FIG. (1) SCHEMATIC OF TEST CONFIGURATION



FIG. (2) WAKE SURVEY RAKES

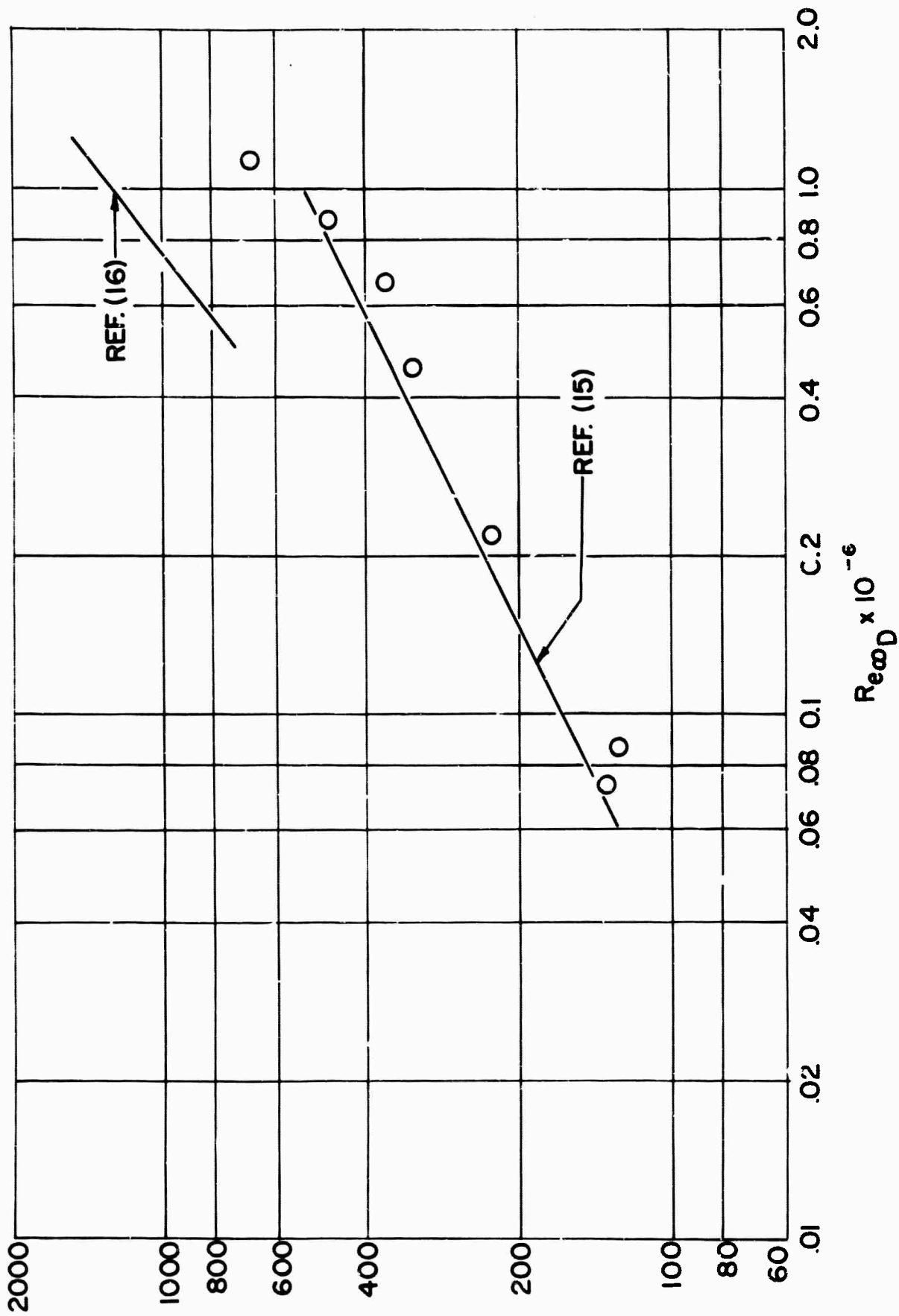

FIG. (3) SURFACE HEAT TRANSFER VS. REYNOLDS NUMBER
(a) $\bar{S} = 1.96$

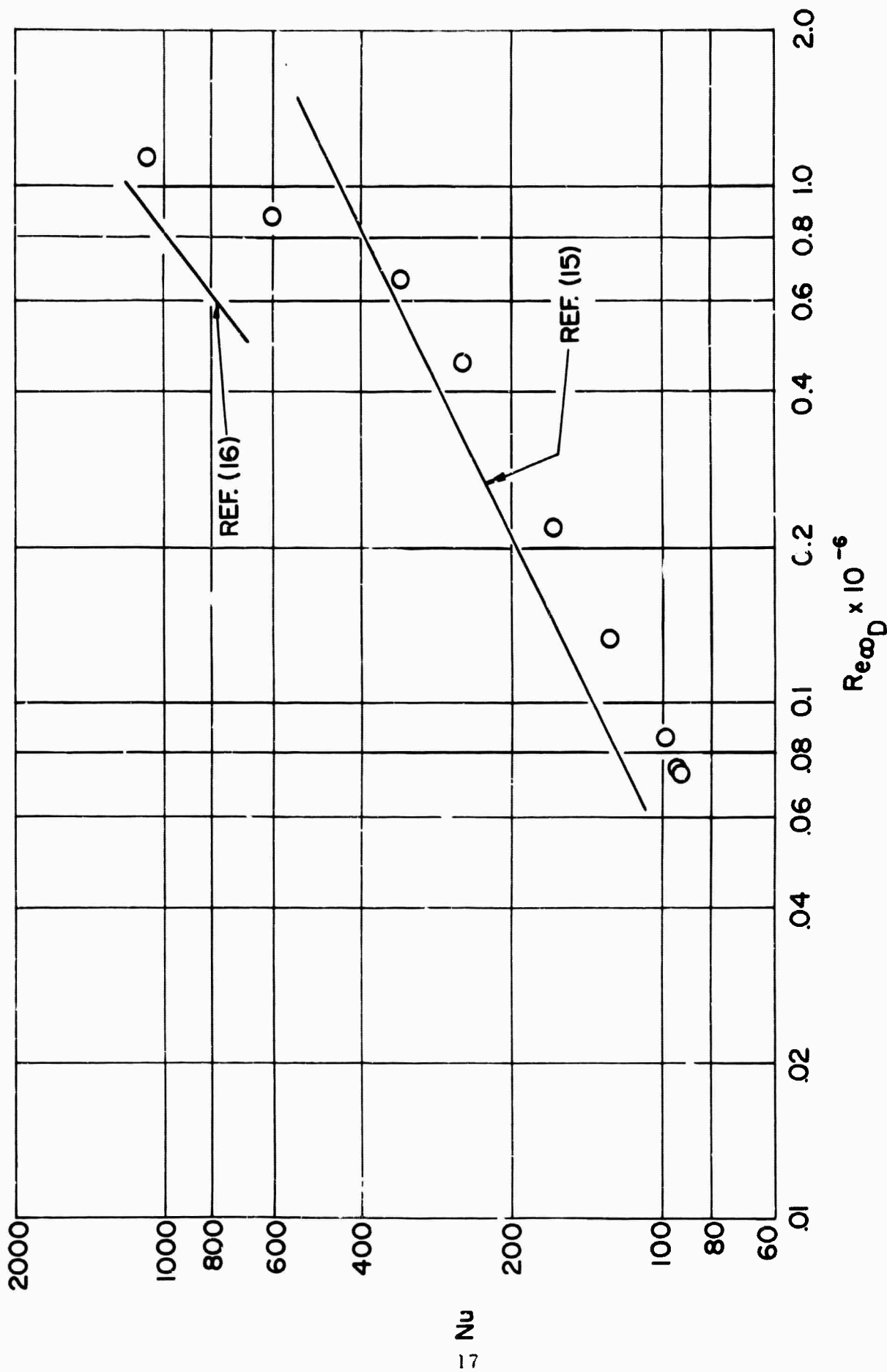

FIG. (3) SURFACE HEAT TRANSFER VS. REYNOLDS NUMBER
 (b) $\bar{\epsilon} = 2.80$

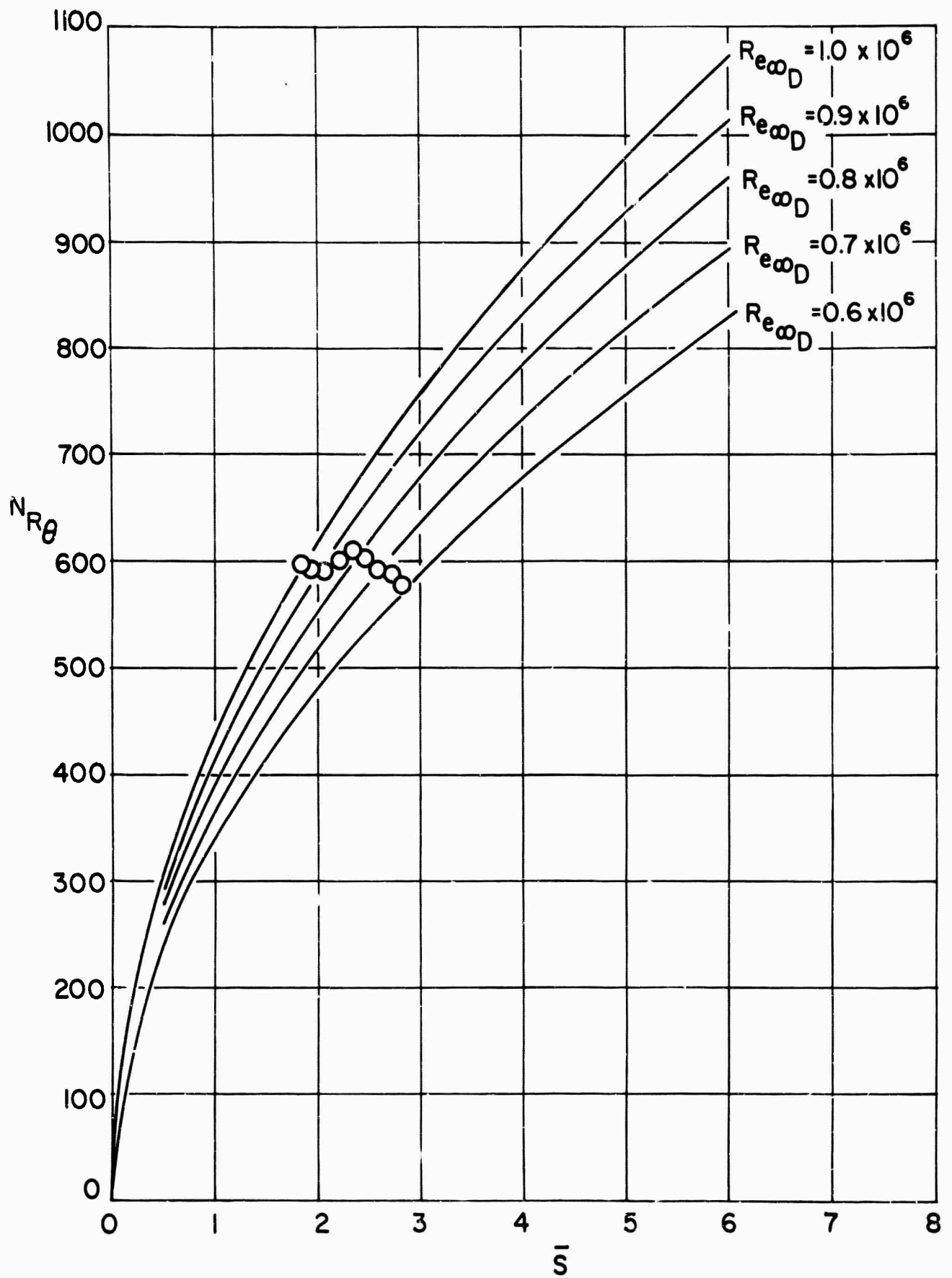

FIG. (4) LOCATION OF BOUNDARY LAYER TRANSITION

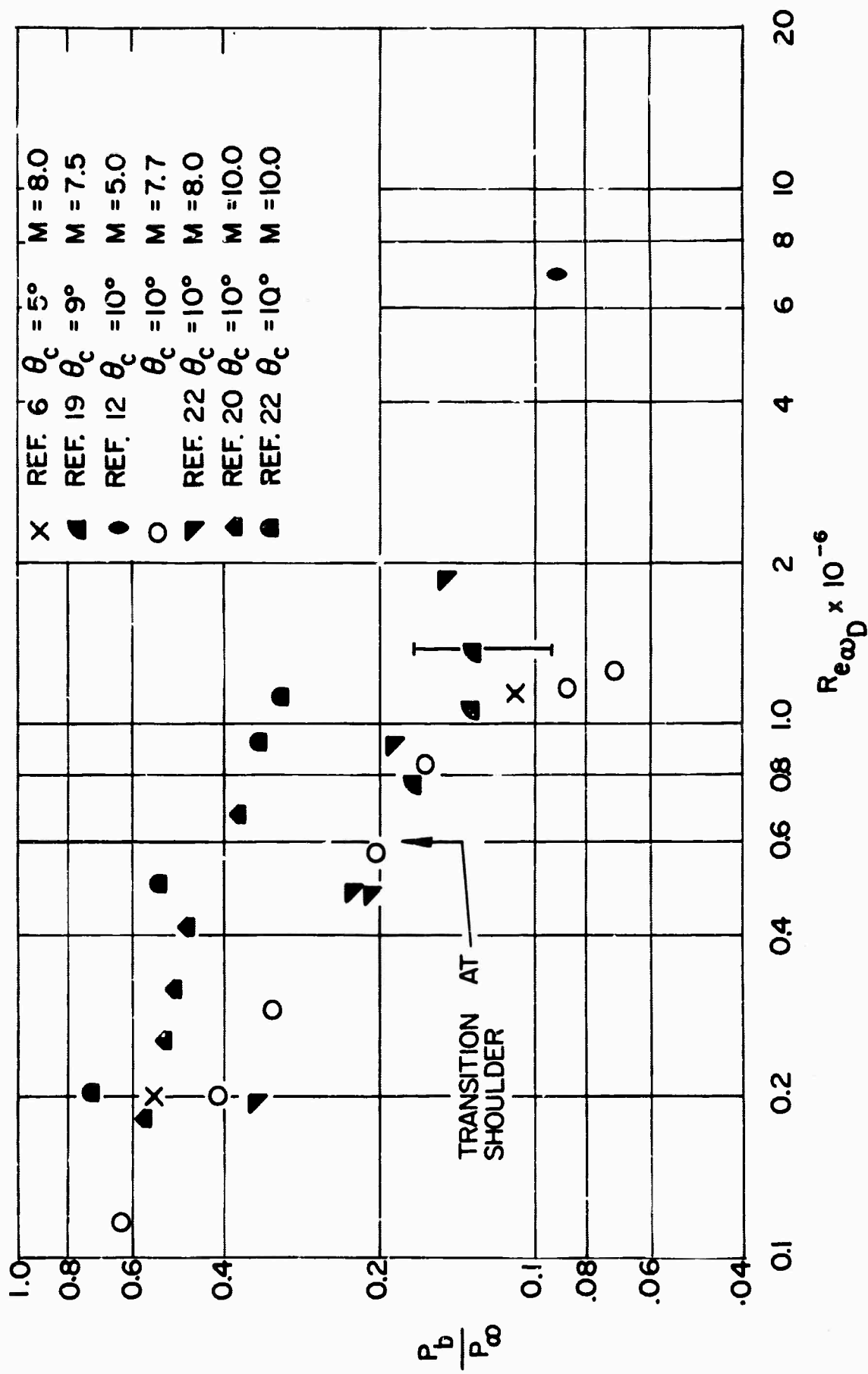

FIG. (5) BASE PRESSURE VS. REYNOLDS NUMBER

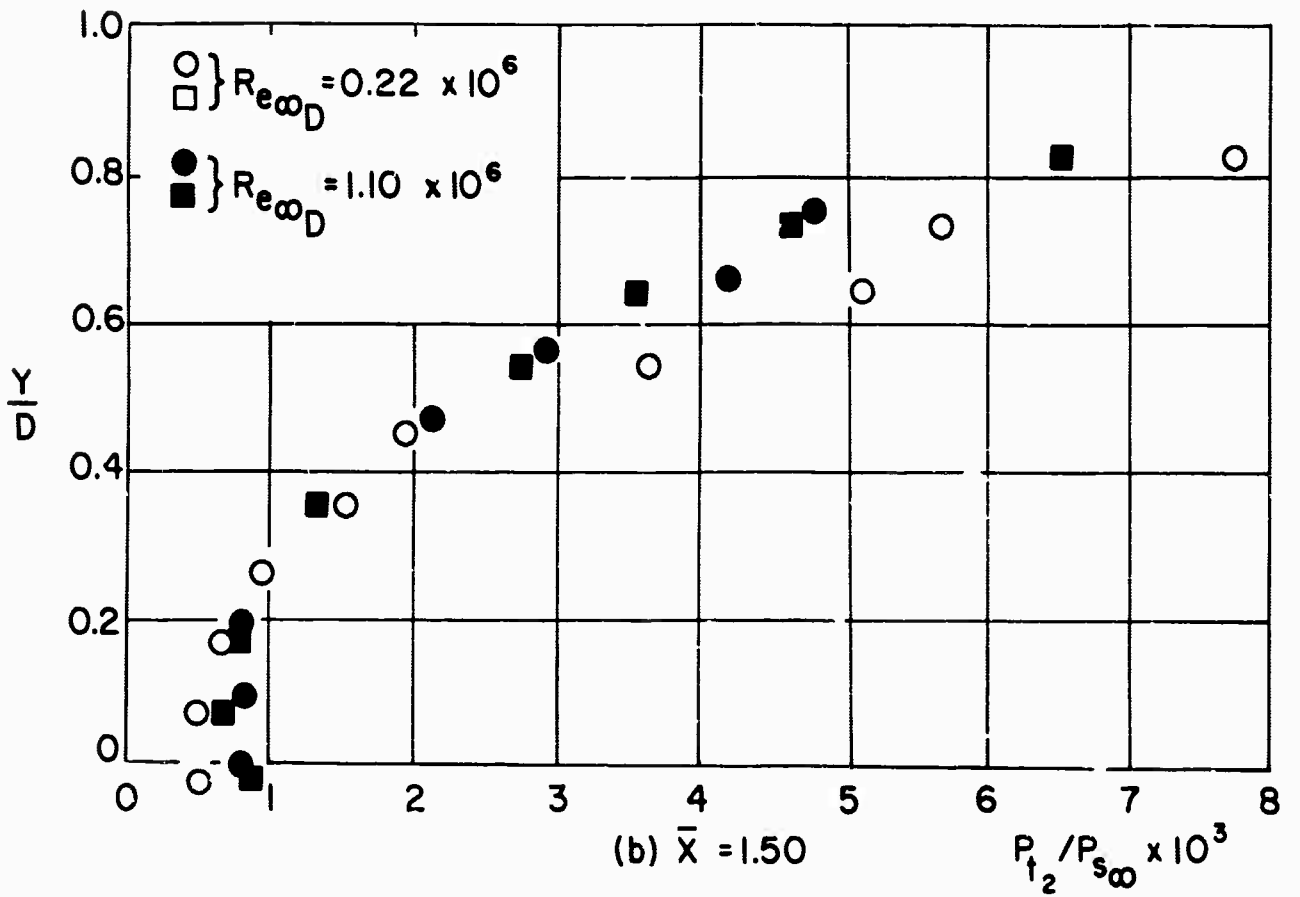
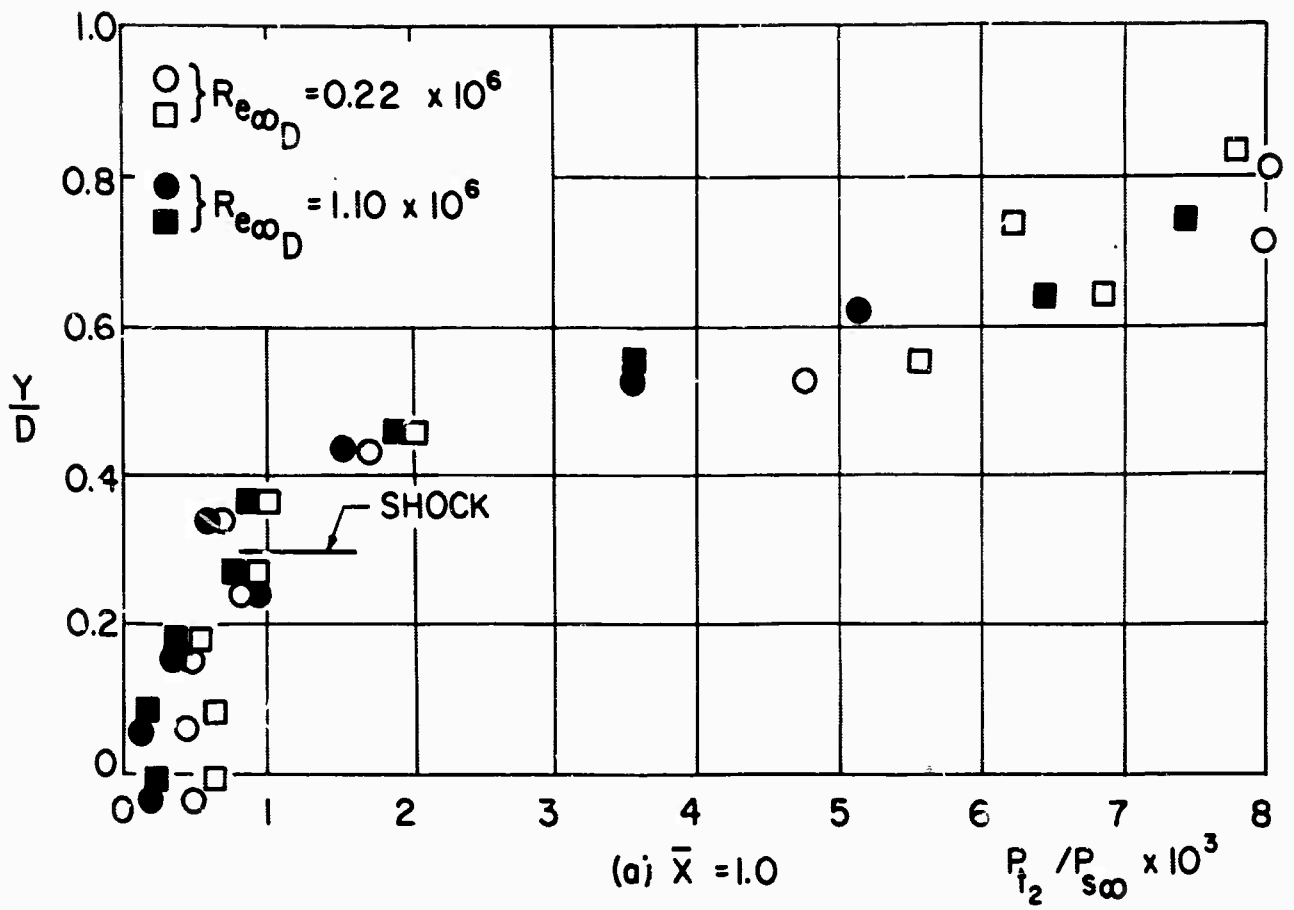

FIG. (6) PITOT PRESSURE PROFILES

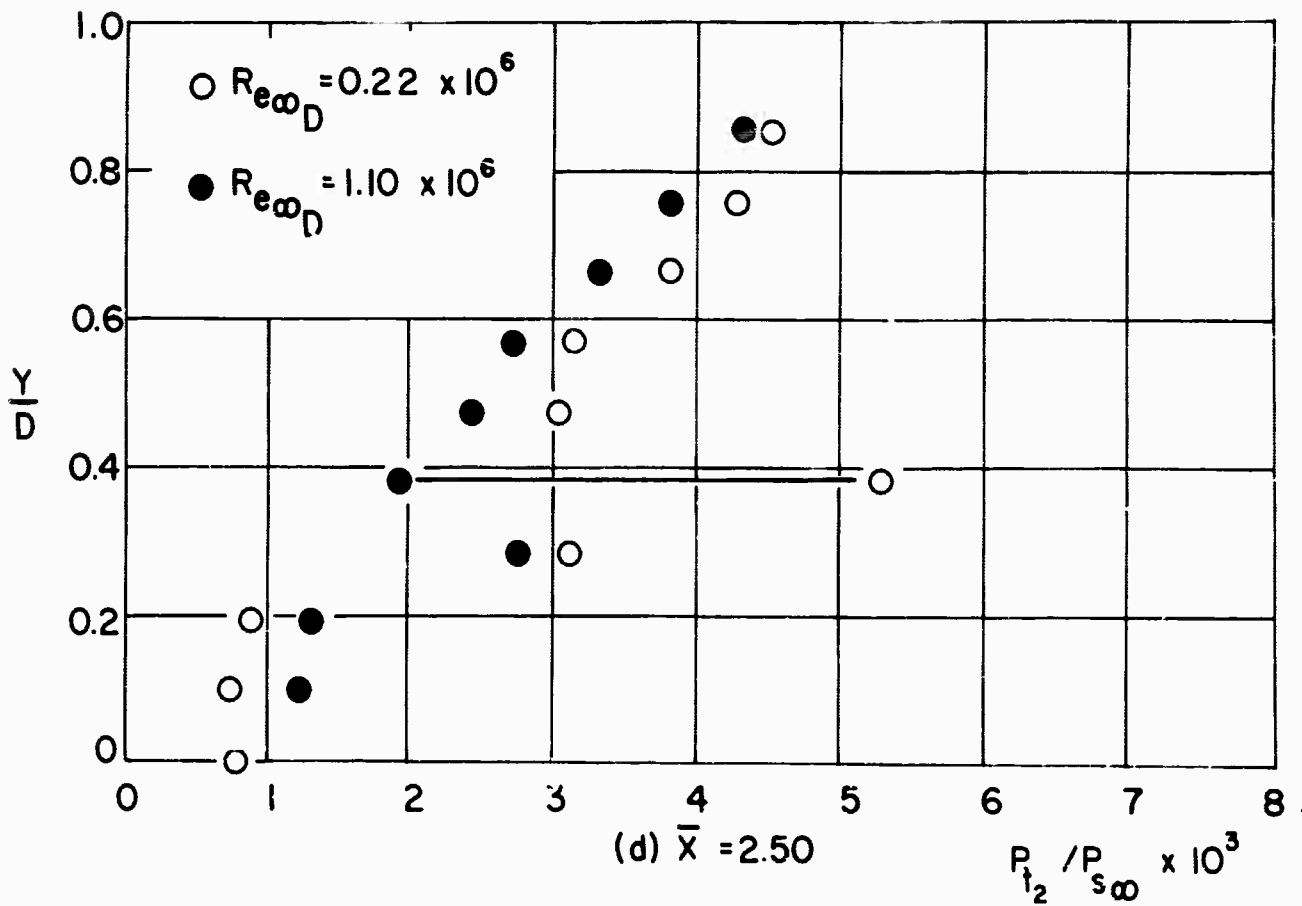
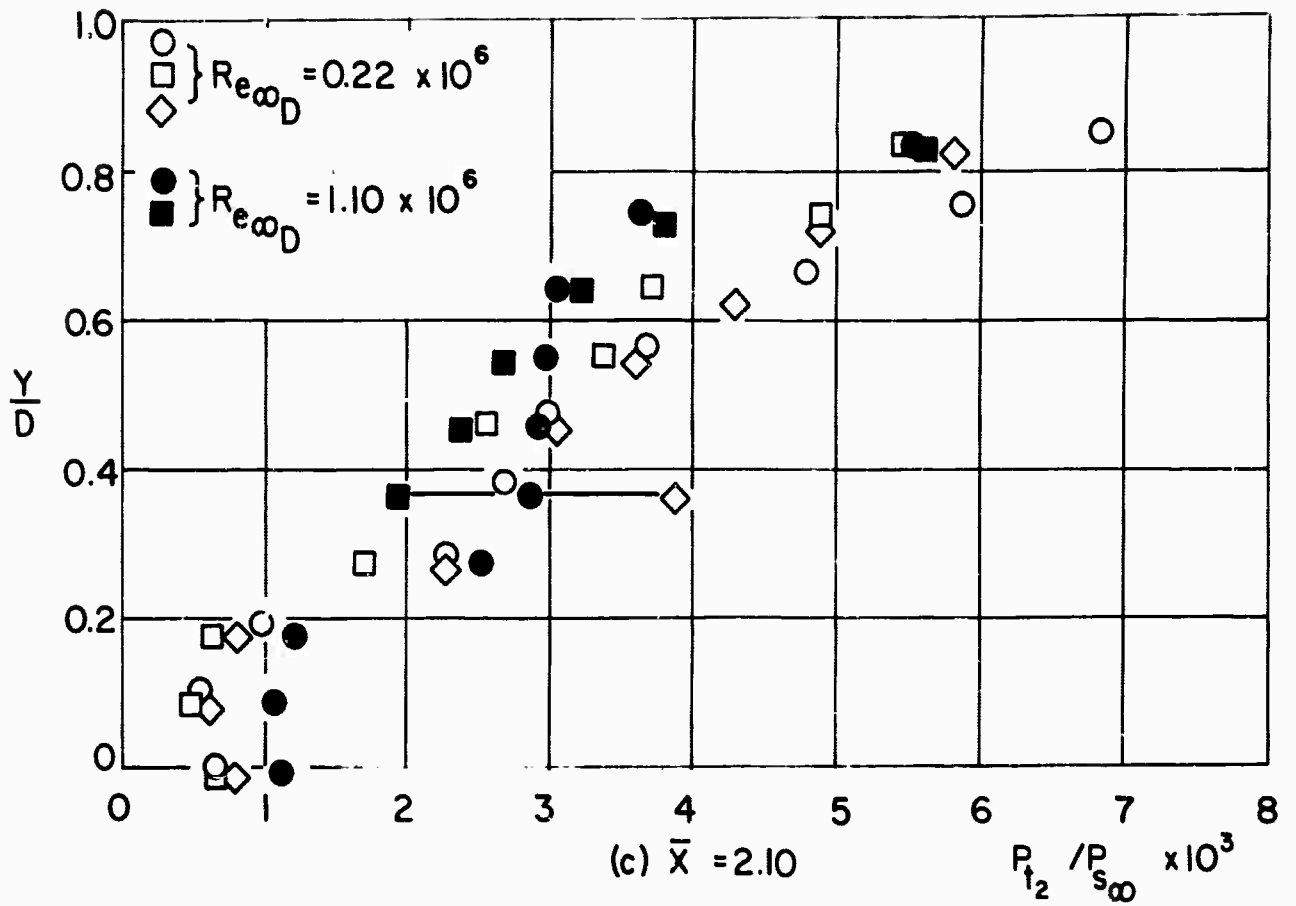

FIG. (6) PITOT PRESSURE PROFILES

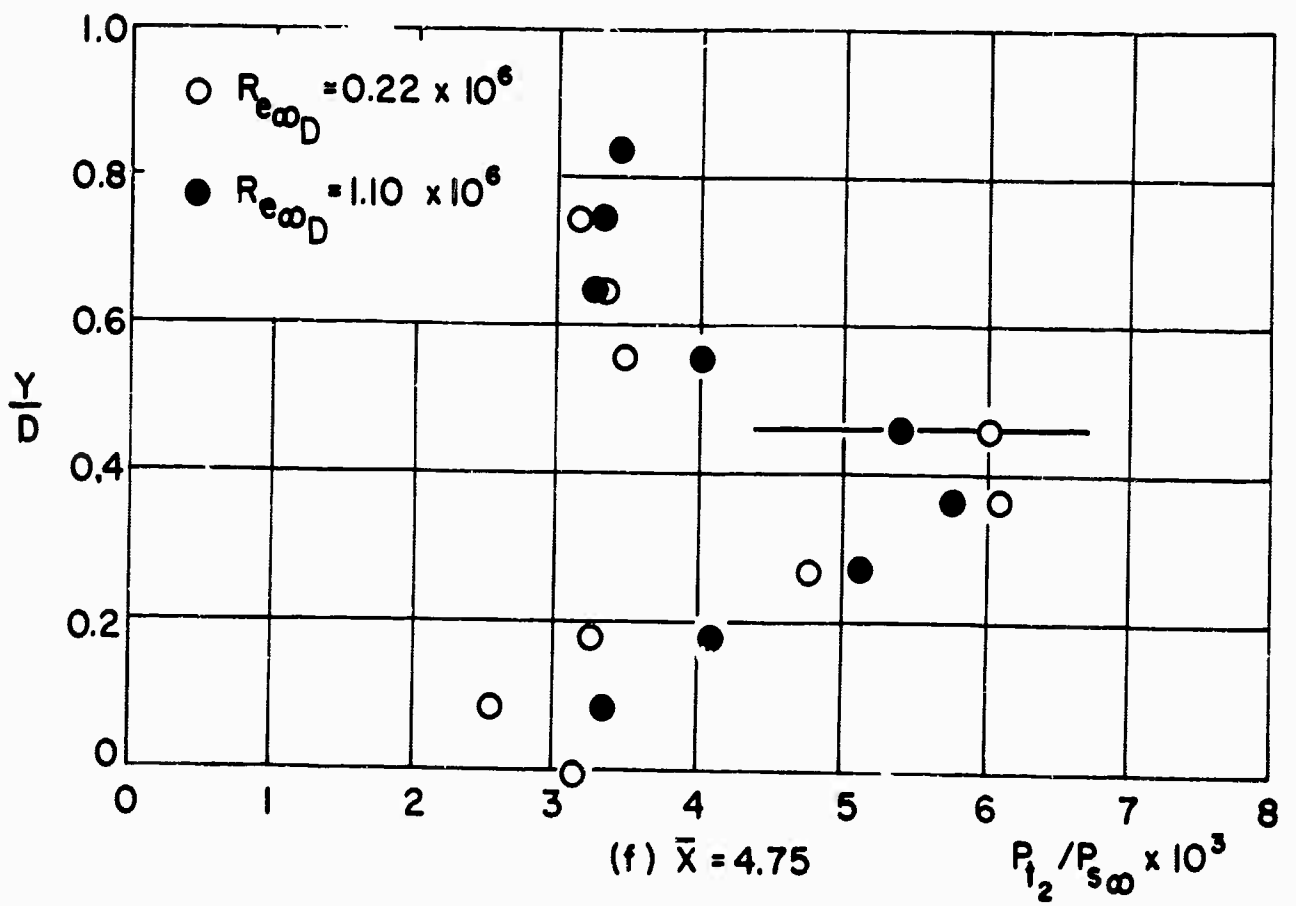
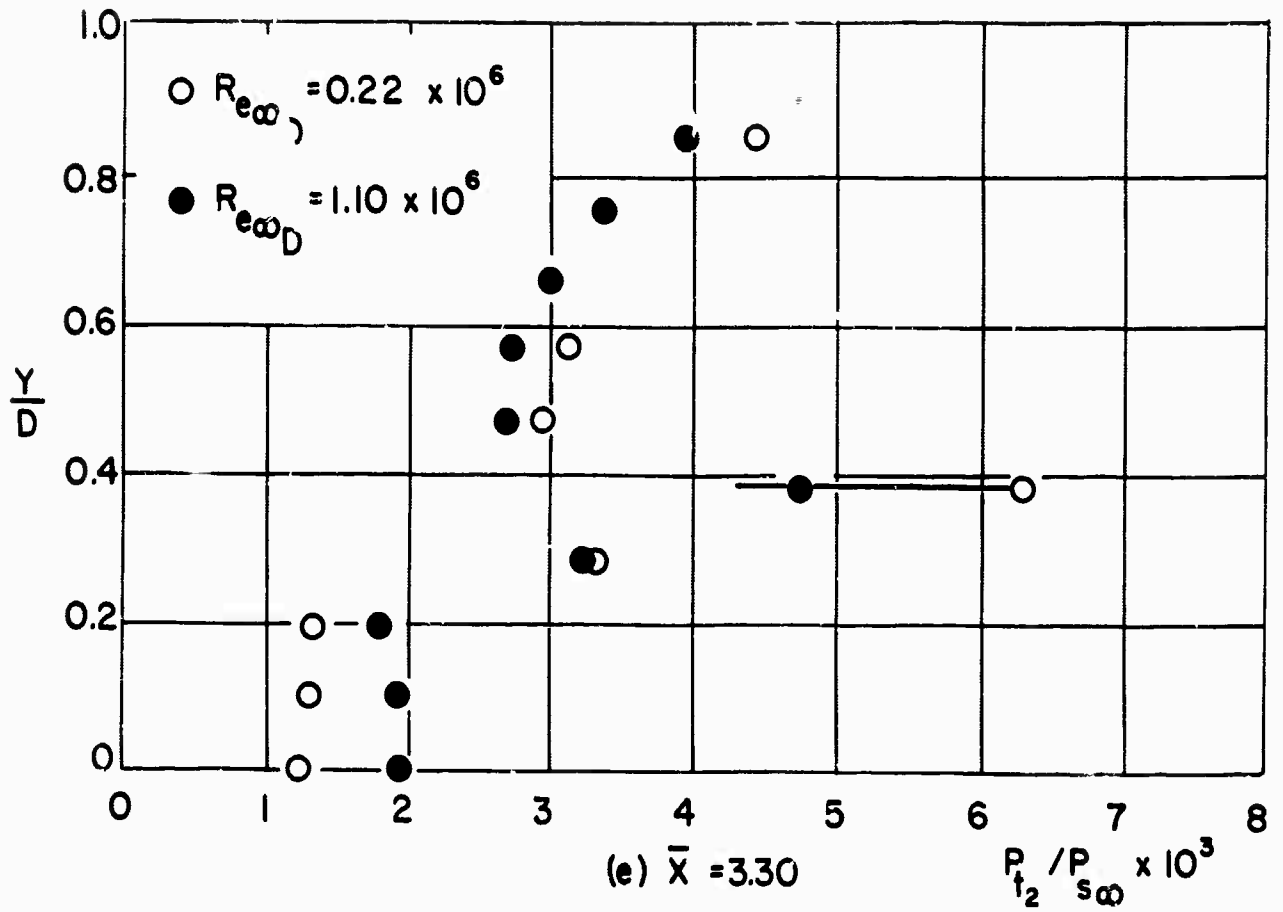

FIG. (6) PITOT PRESSURE PROFILES

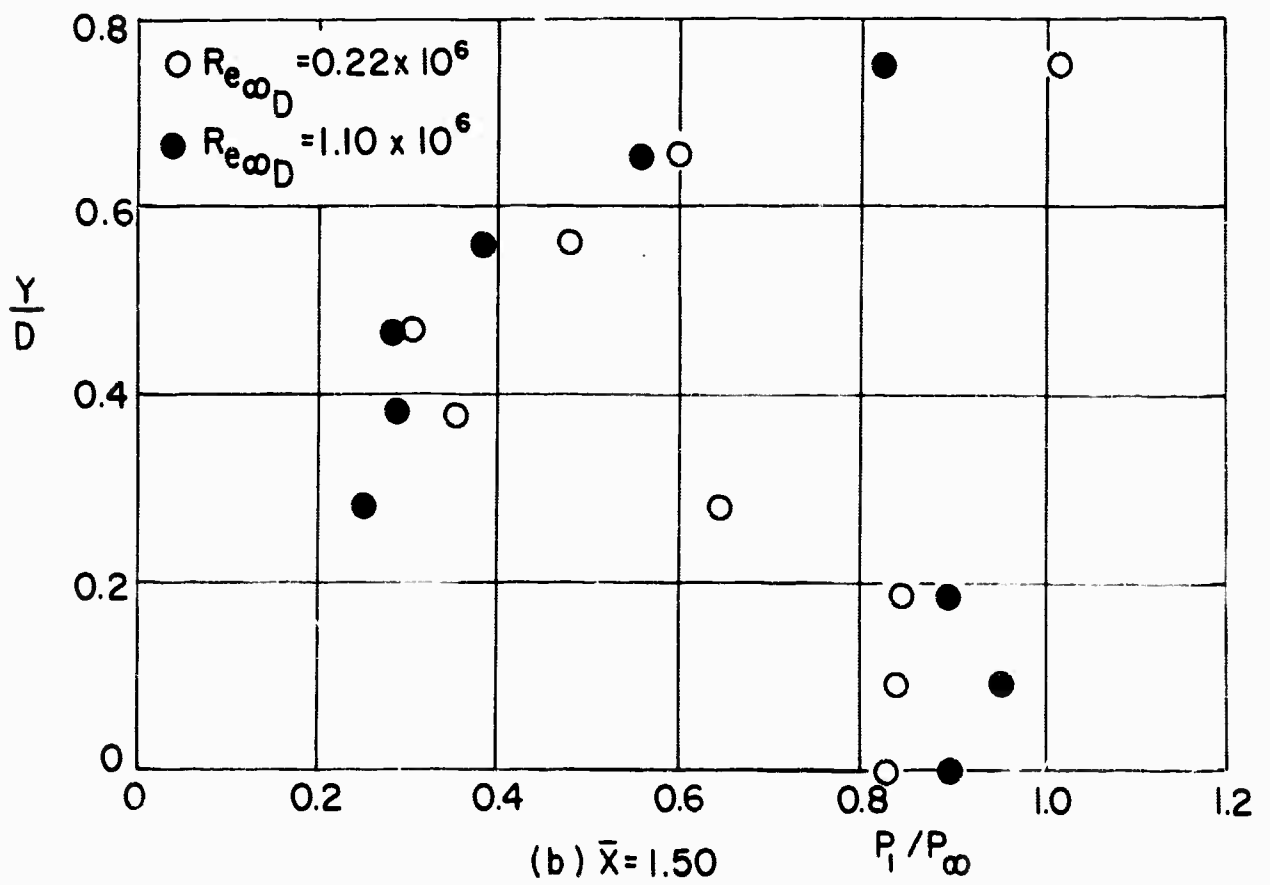
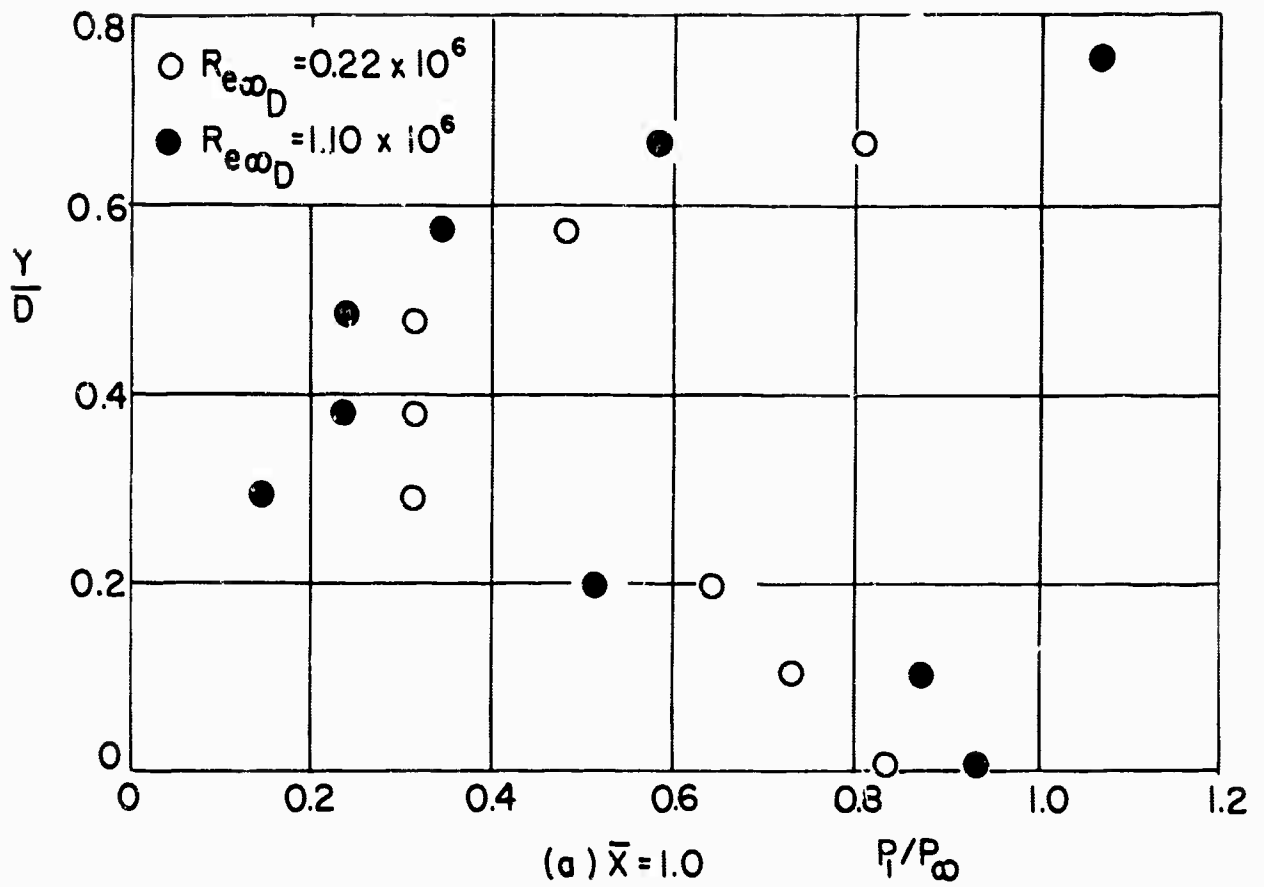

FIG. (7) STATIC PRESSURE PROFILES

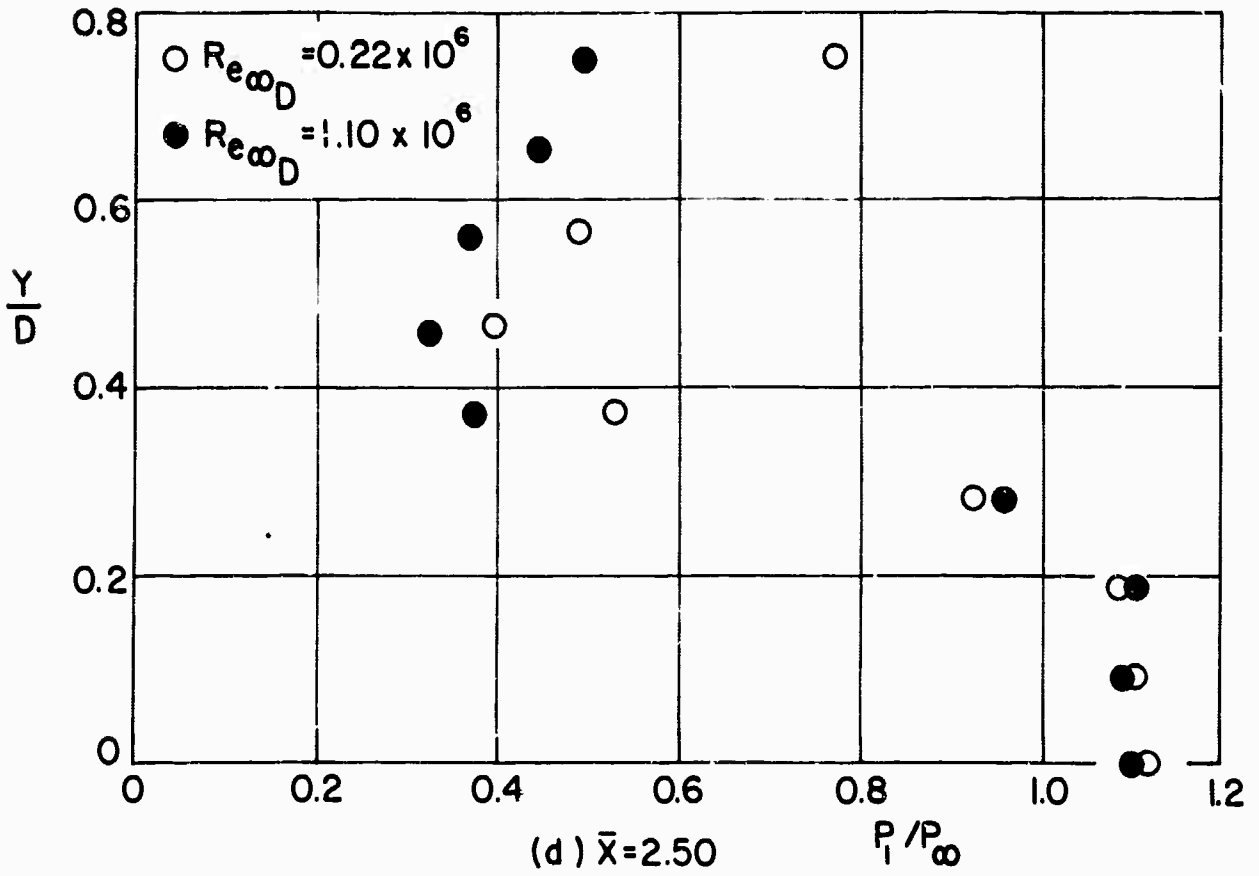
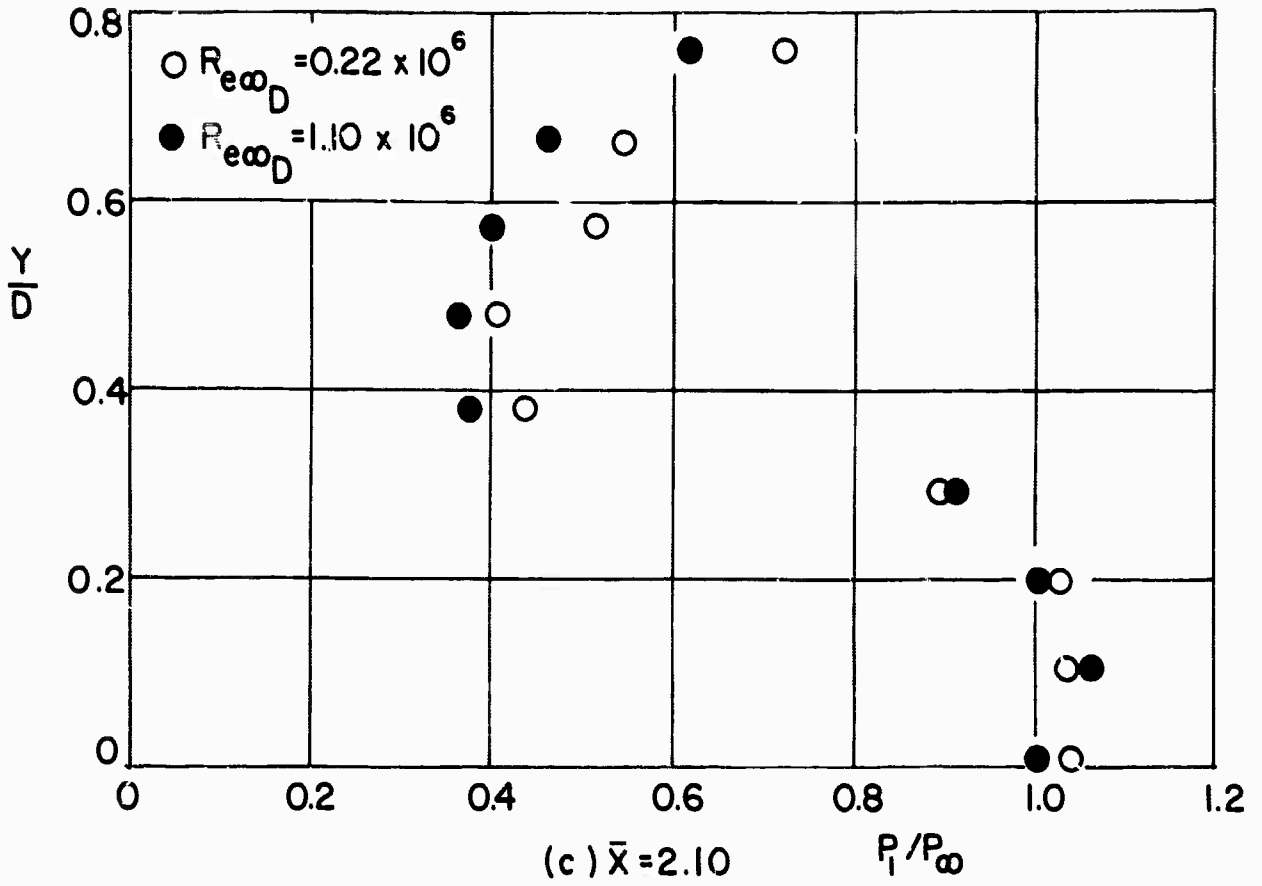

FIG.(7) STATIC PRESSURE PROFILES

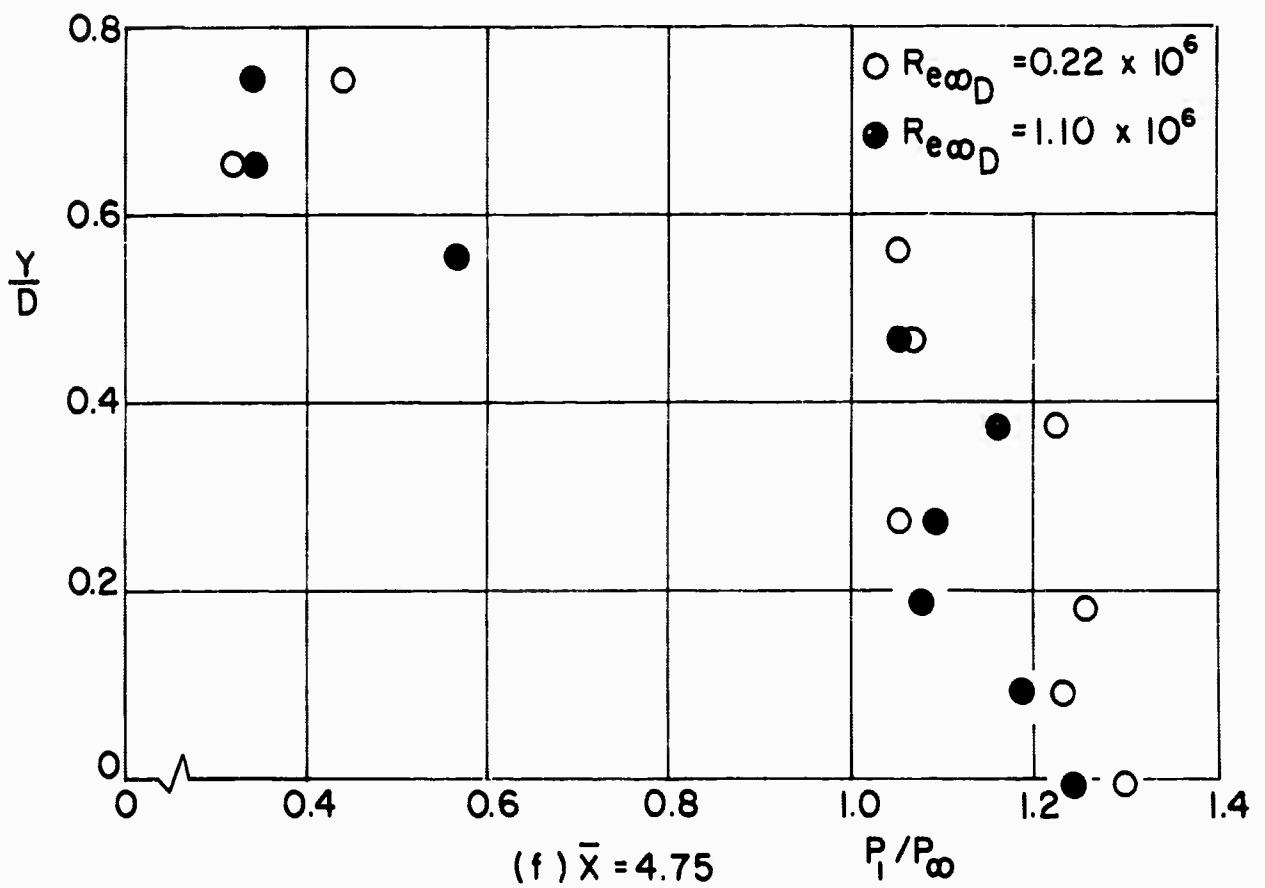
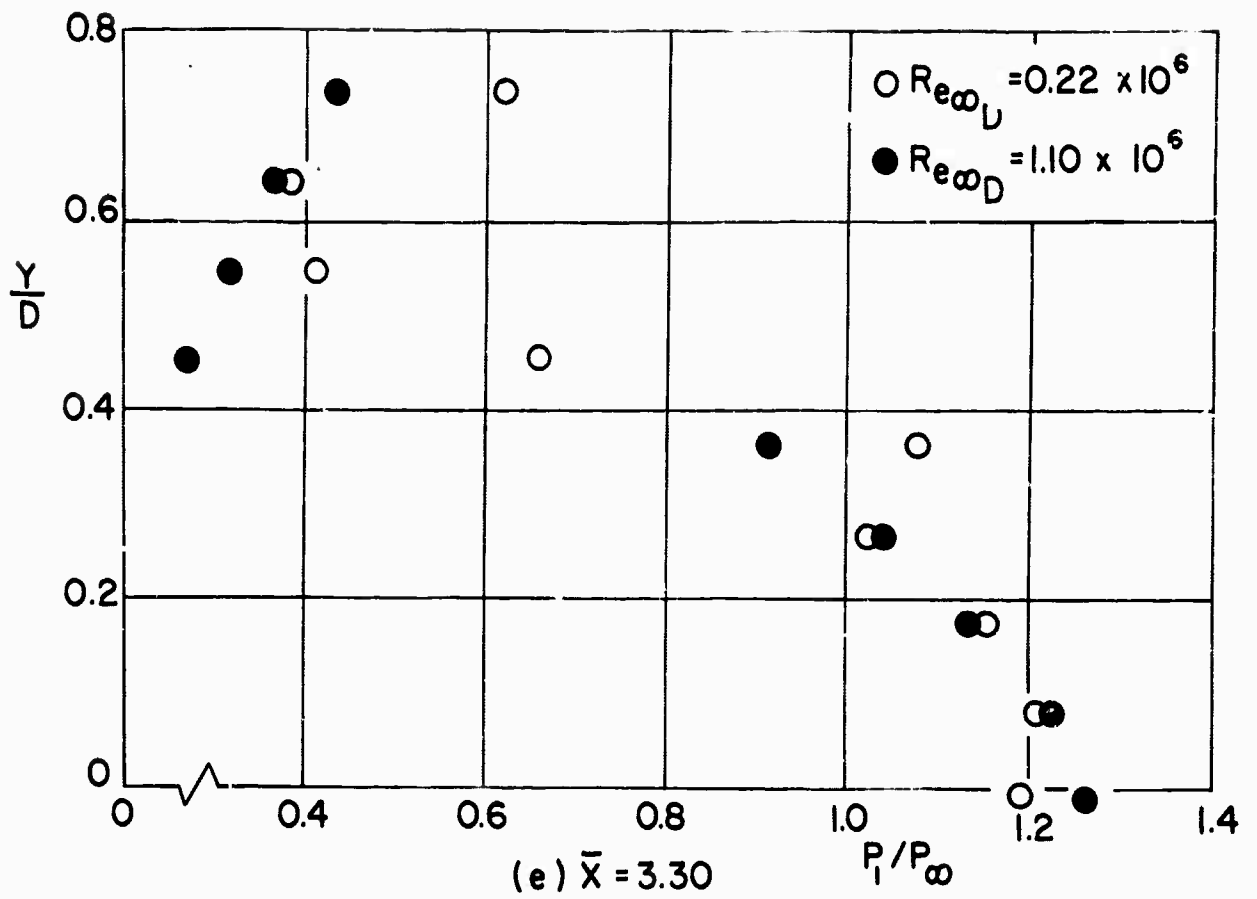

FIG. (7) STATIC PRESSURE PROFILES

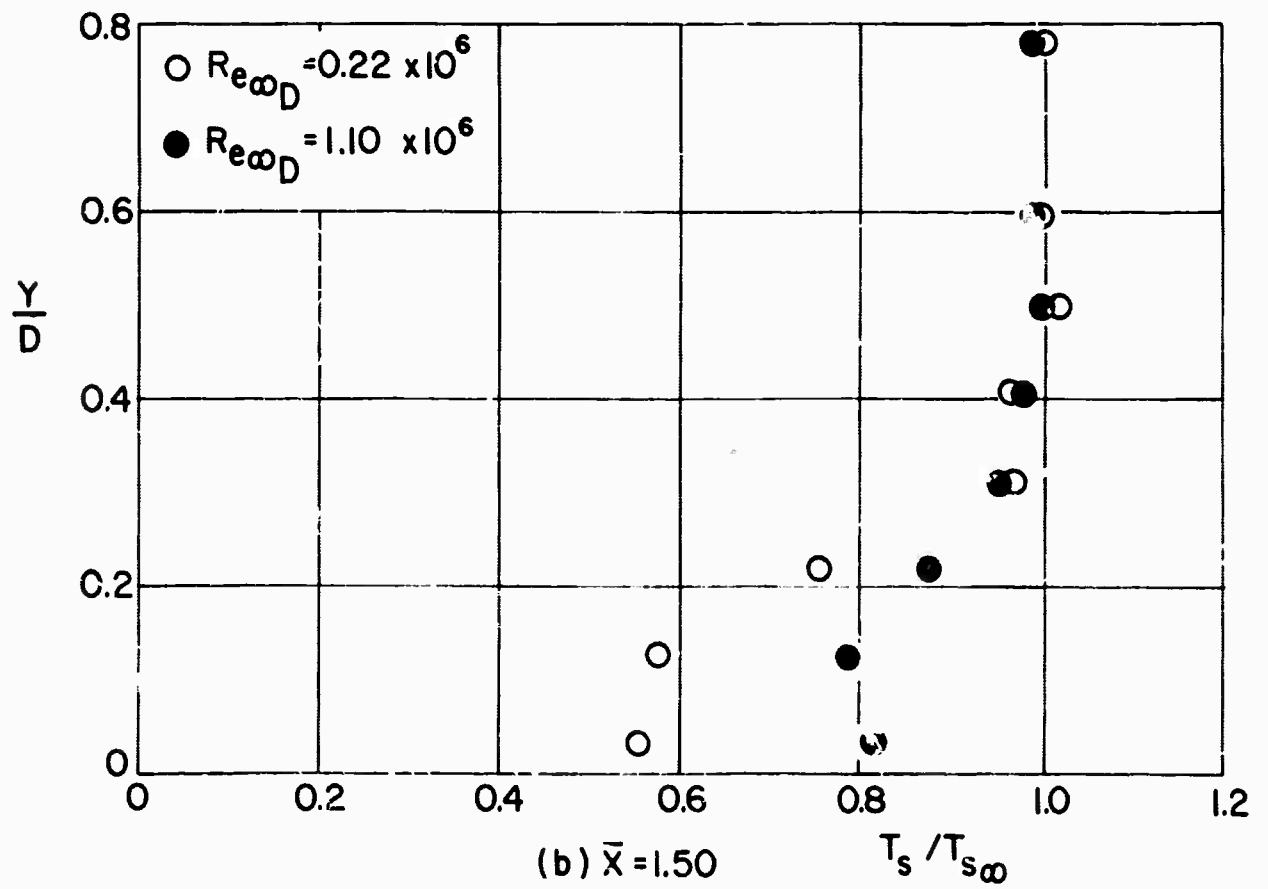
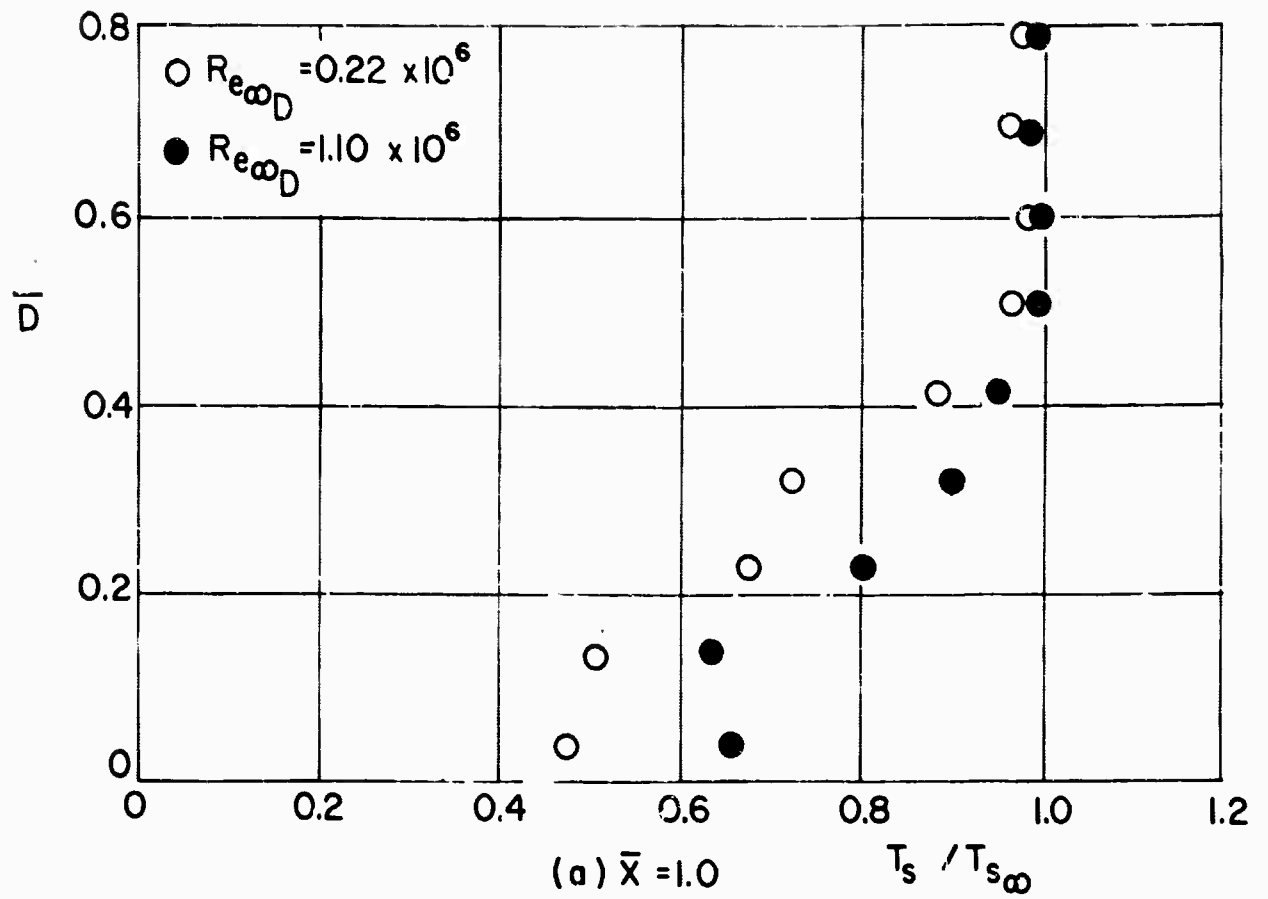

FIG. (8) TOTAL TEMPERATURE PROFILES

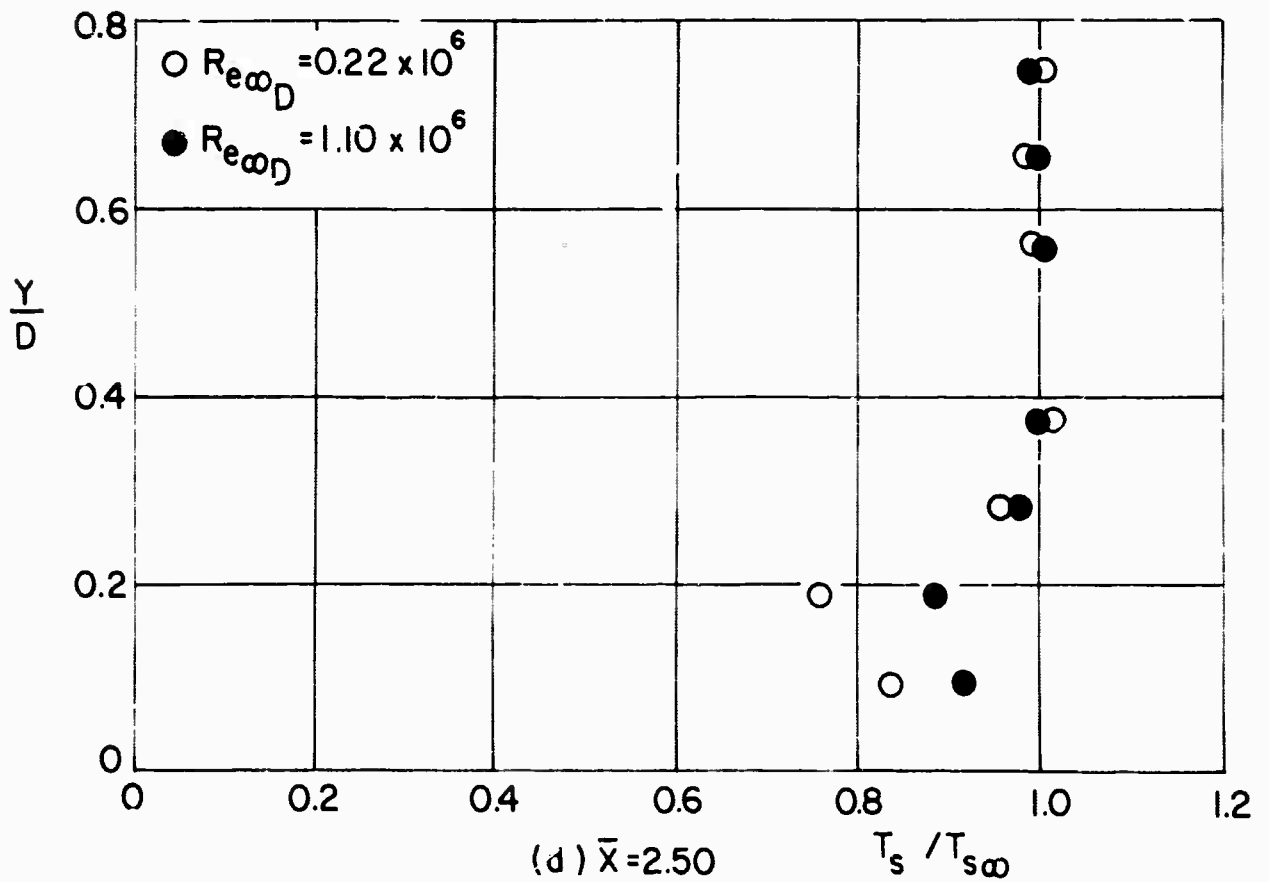
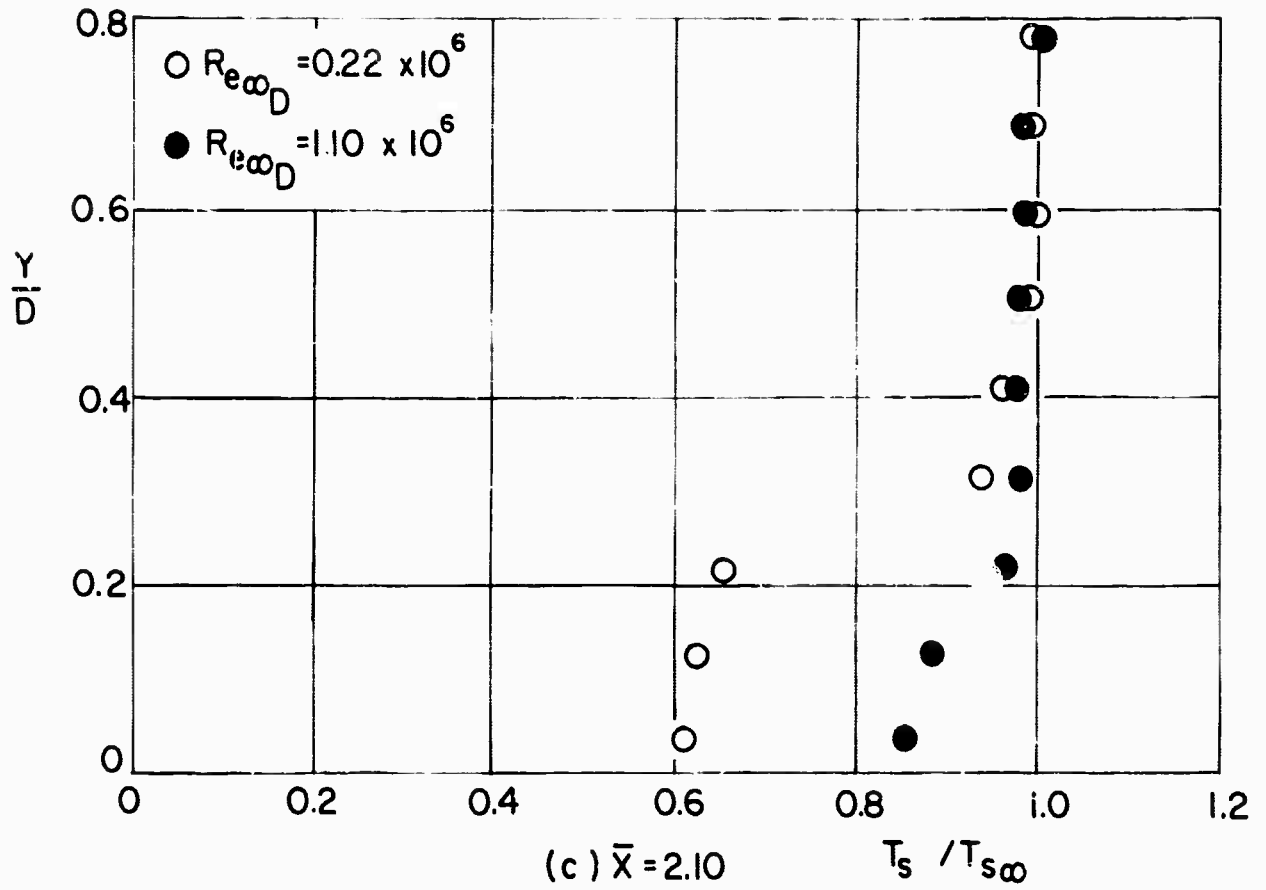

FIG. (8) TOTAL TEMPERATURE PROFILES

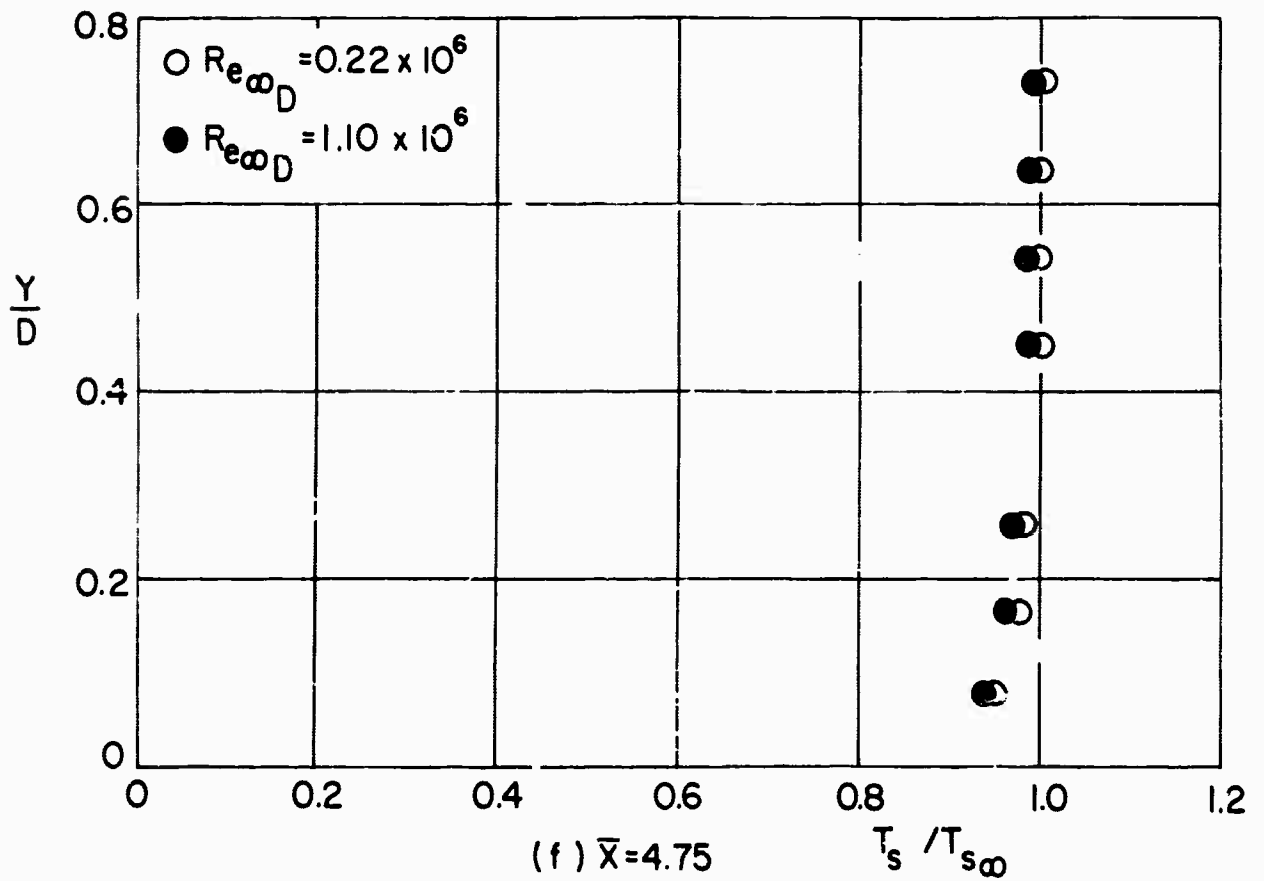
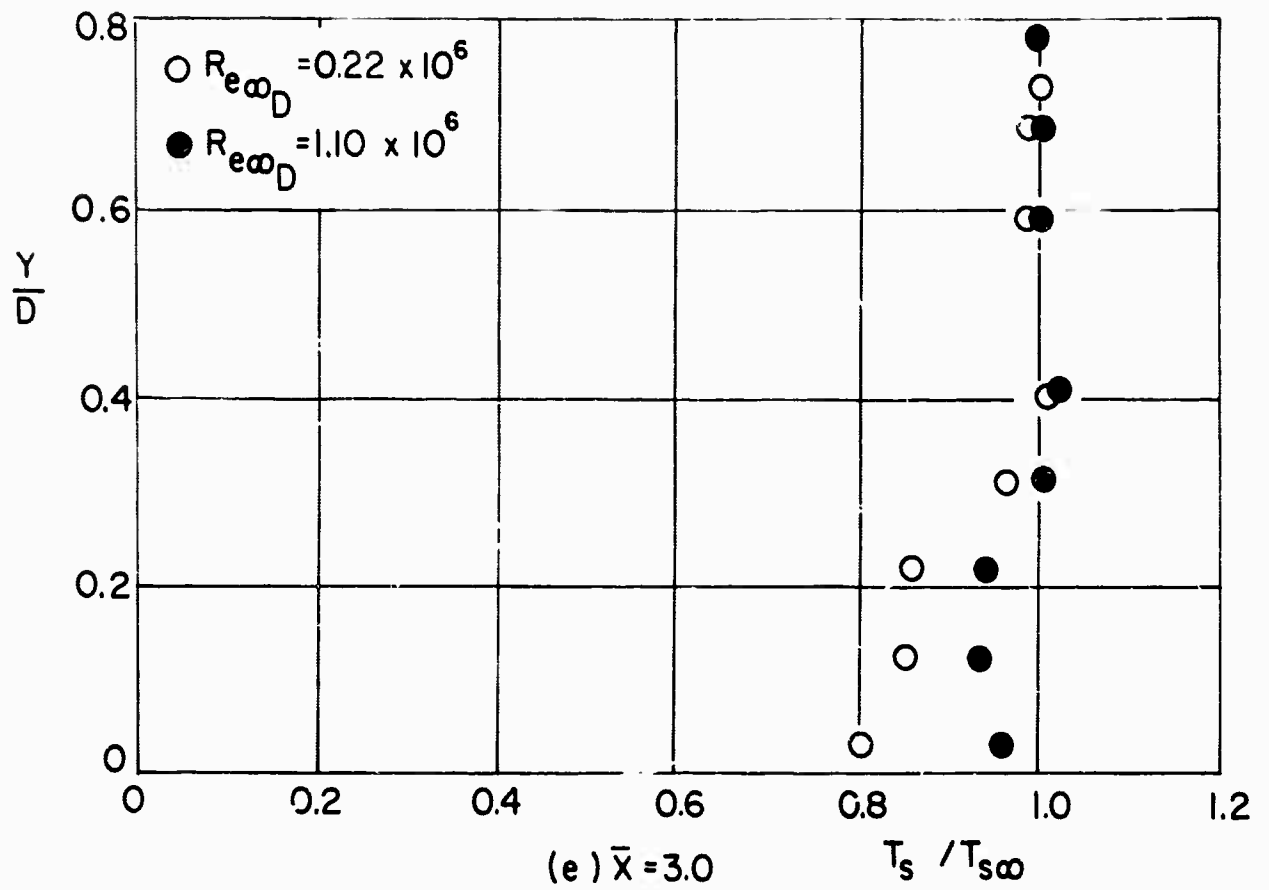

FIG.(8) TOTAL TEMPERATURE PROFILES

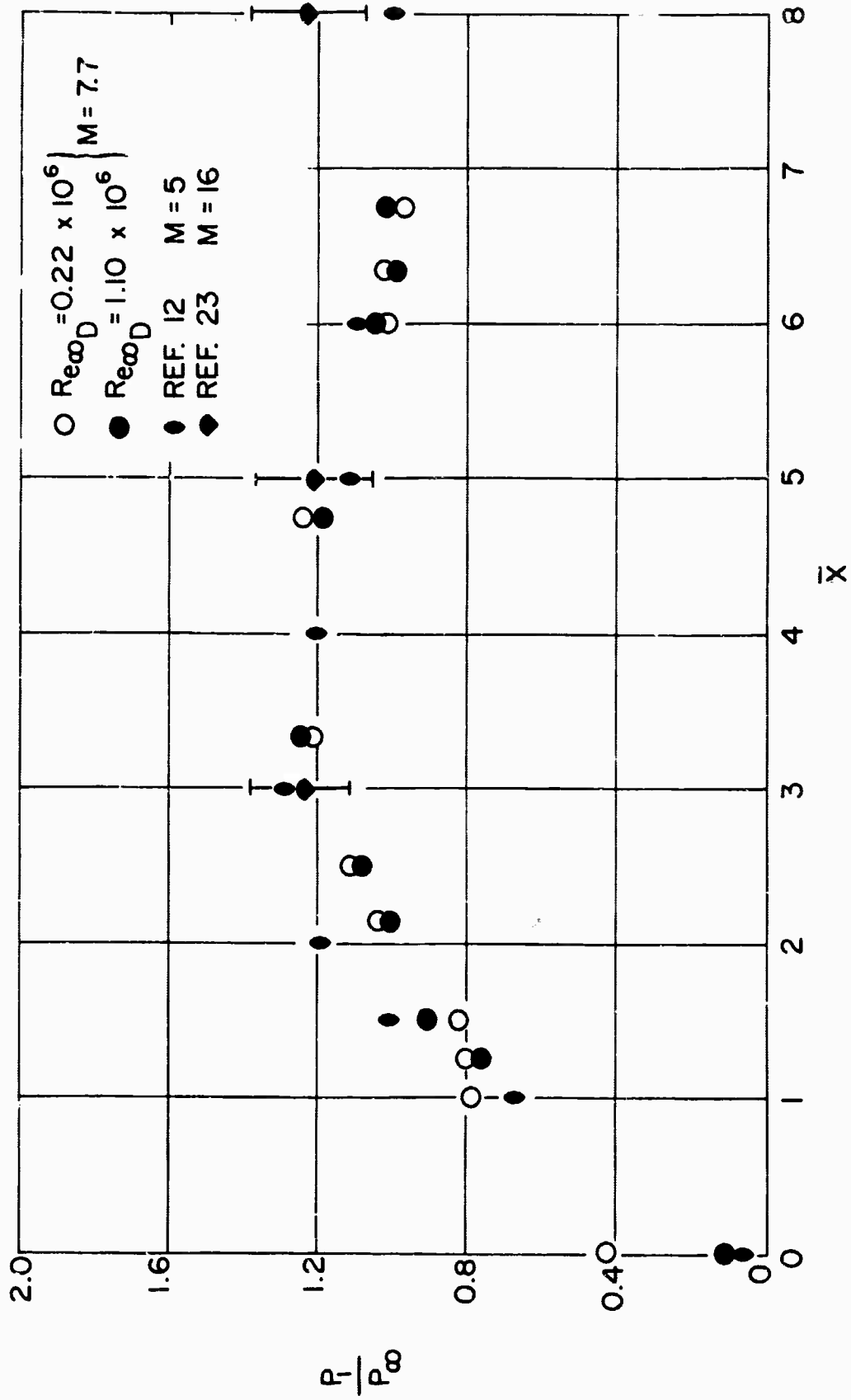

FIG. (9) CENTERLINE DISTRIBUTION OF STATIC PRESSURE

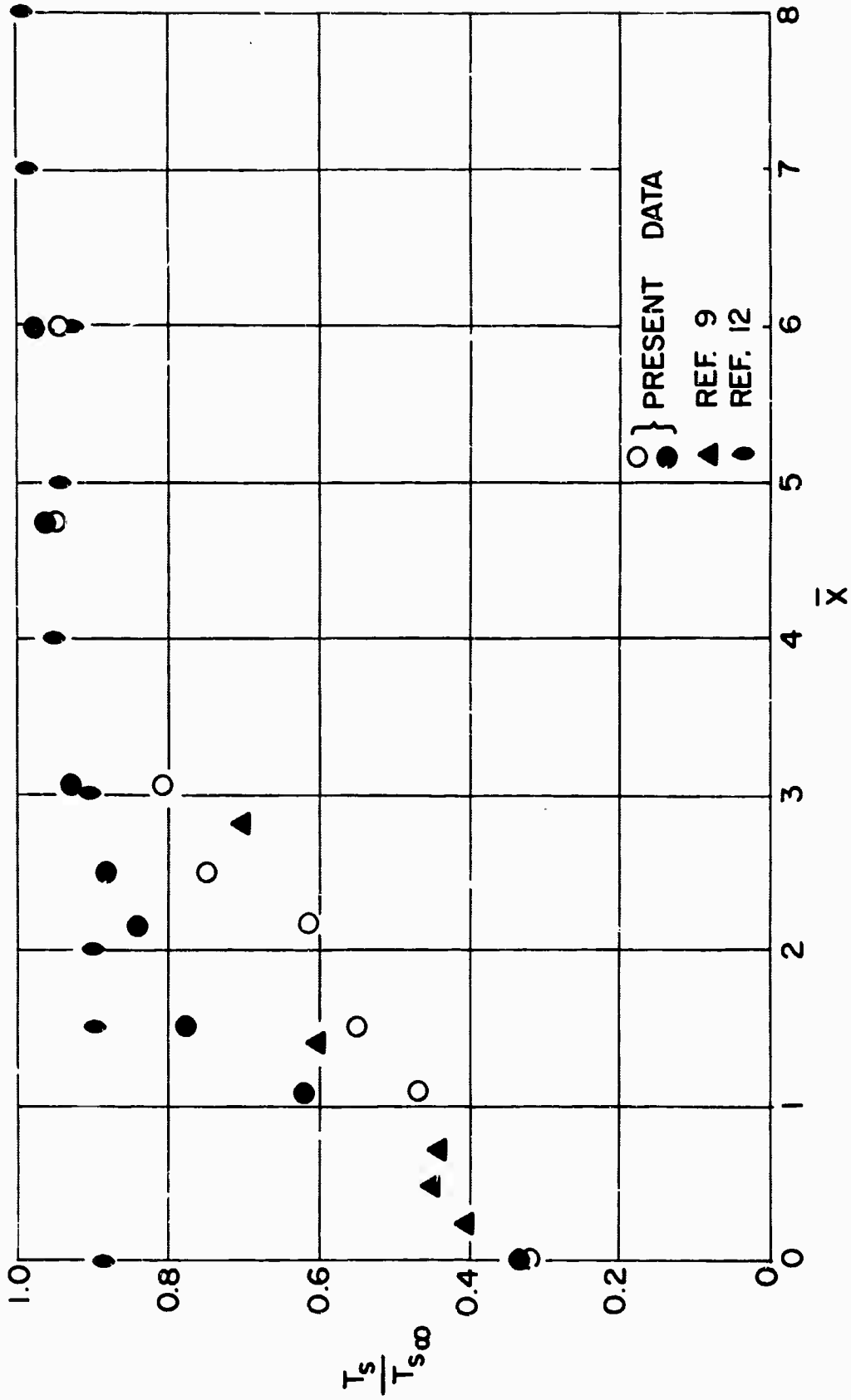

FIG. (10) CENTERLINE DISTRIBUTION OF STAGNATION TEMPERATURE

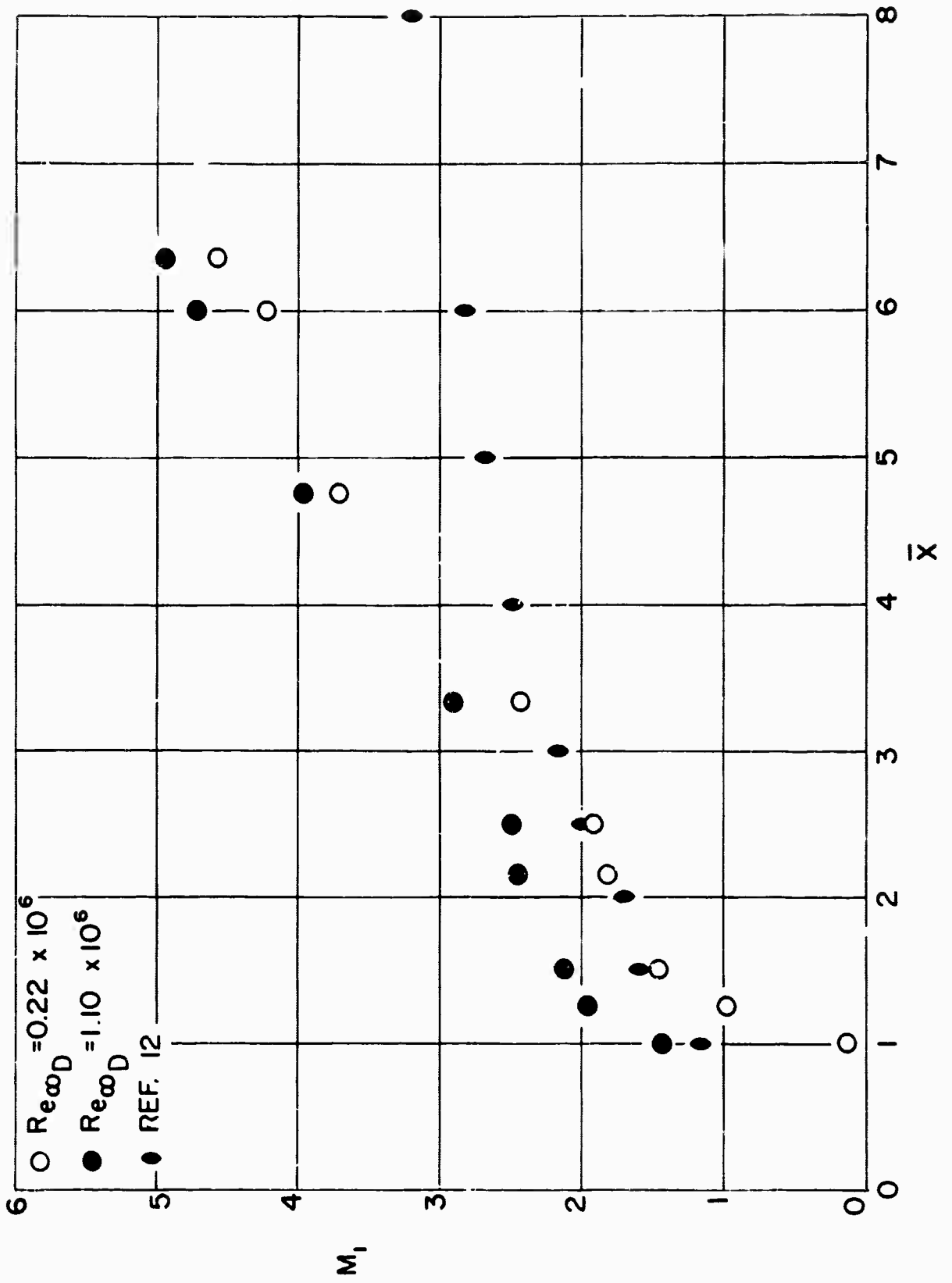

FIG. (II) CENTERLINE DISTRIBUTION OF MACH NUMBER

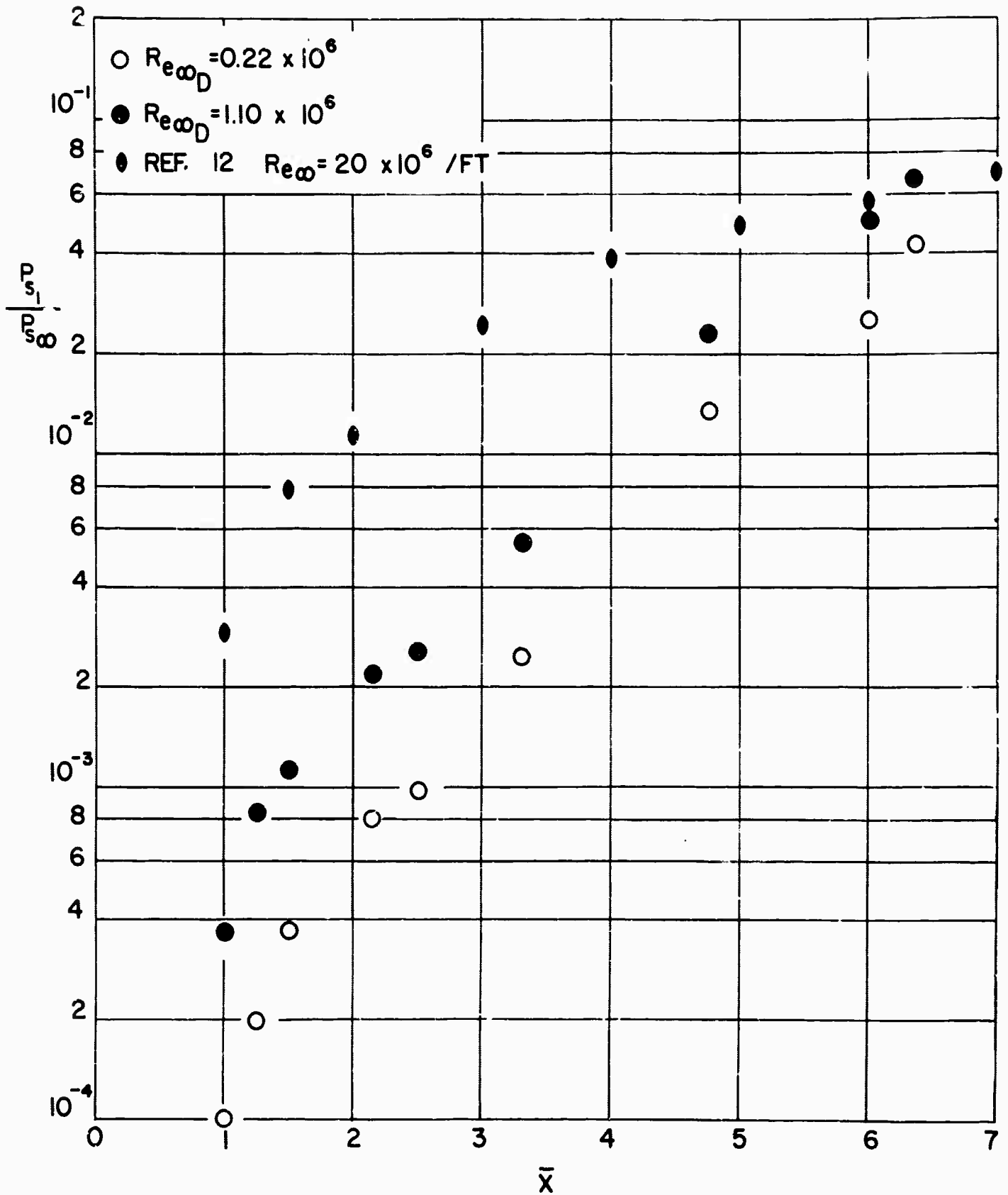

FIG. (12) CENTERLINE DISTRIBUTION OF STAGNATION PRESSURE

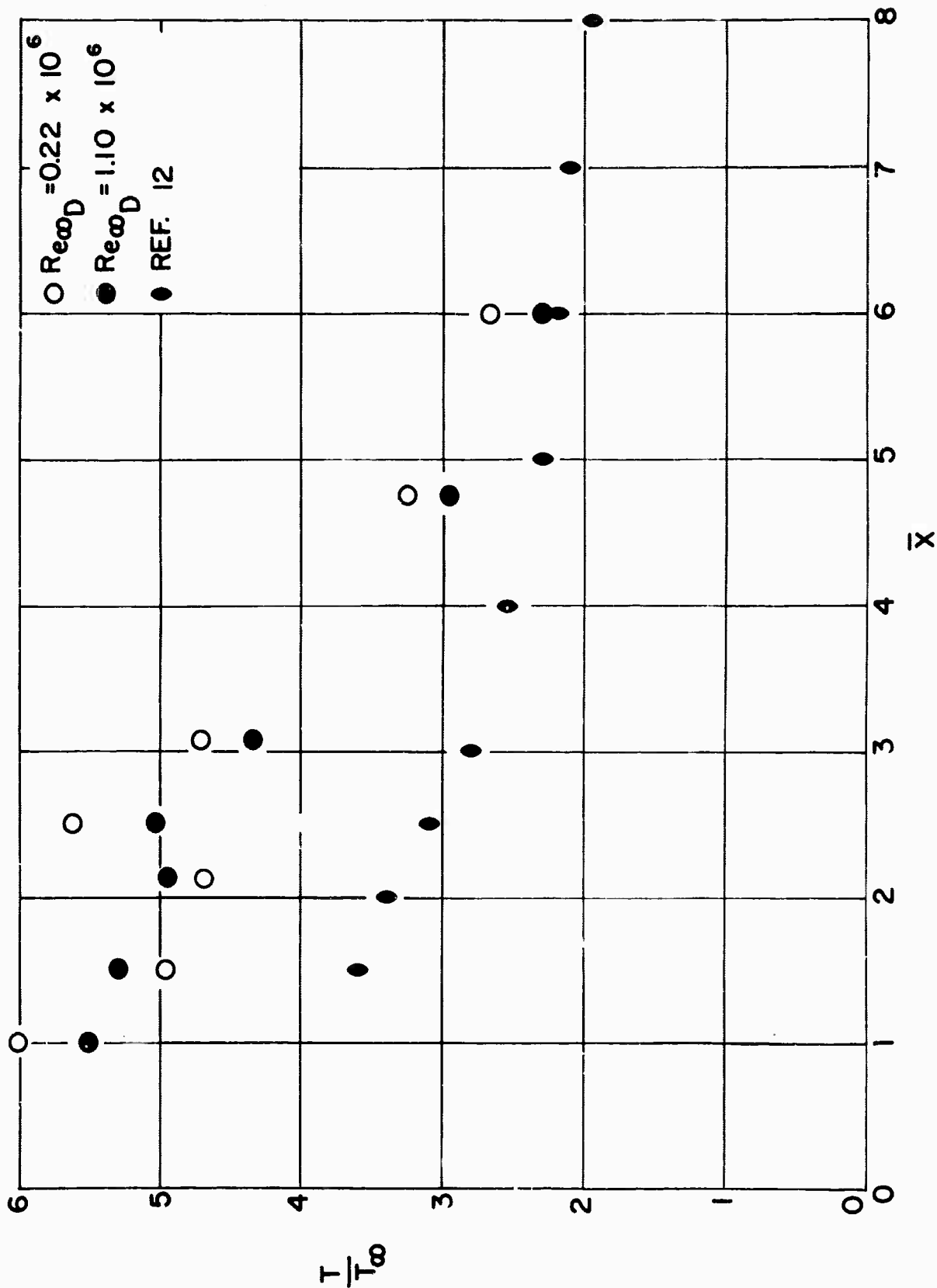

FIG. (13) CFENTERLINE DISTRIBUTION OF STATIC TEMPERATURE

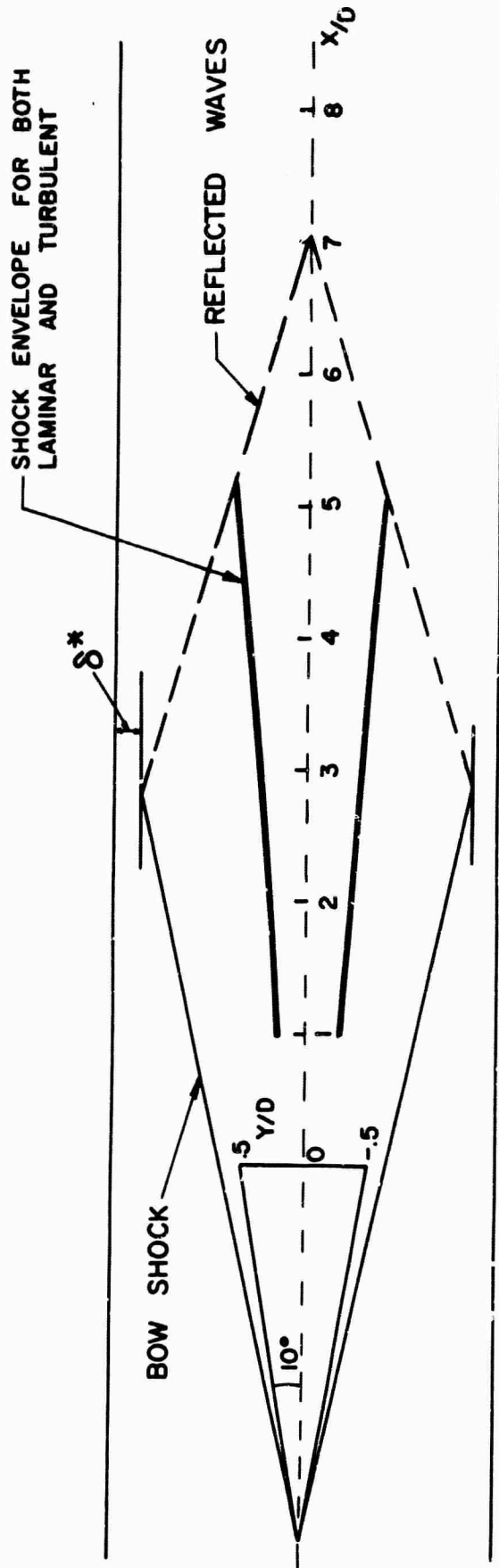

FIG. (14) TRAILING SHOCK CONFIGURATIONS

DOCUMENT CONTROL DATA - R & D

(Security Classification of title, body of abstract and indexing annotation must be entered when the overall report is classified)

1. ORIGINATING ACTIVITY (Corporate author) Polytechnic Institute of Brooklyn Dept. of Aerospace Engrg. and Applied Mechanics Route 110, Farmingdale, New York 11735		2a. REPORT SECURITY CLASSIFICATION Unclassified	
		2b. GROUP	
3. REPORT TITLE AN EXPERIMENTAL INVESTIGATION OF HYPERSONIC FLOW AROUND A SLENDER CONE			
4. DESCRIPTIVE NOTES (Type of report and inclusive dates) Research Report			
5. AUTHOR(S) (First name, middle initial, last name) Edward M. Schmidt and Robert J. Cresci			
6. REPORT DATE October 1967	7a. TOTAL NO. OF PAGES	7b. NO. OF PAGES 26	
8a. CONTRACT OR GRANT NO Nonr 839 (38)	9a. ORIGINATOR'S REPORT NUMBER(S) PIBAL REPORT No. 1031		
b. PROJECT NO			
c. ARPA Order No. 529	9b. OTHER REPORT NUMBER(S) (Any other numbers that may be assigned this report)		
d.			
10. DISTRIBUTION STATEMENT Distribution of this document is unlimited.			
11. SUPPLEMENTARY NOTES		12. SPONSORING/MILITARY AGENCY Office of Naval Research Department of the Navy Washington, D. C.	
13. ABSTRACT This paper presents the results of an experimental survey of the flow field around a sharp, 10° half angle cone. Tests were conducted at a free stream Mach number of 7.7 for a range of free stream Reynolds numbers of 0.11×10^6 to 1.71×10^6 per foot. Surface heat transfer data indicates that the cone boundary layer varies from laminar to fully developed turbulent over this Reynolds number range. The base pressure variation was also obtained throughout this range of Reynolds numbers; from this, the interrelation between the surface boundary layer properties and the base pressure is discussed. A series of tests were conducted in the near wake region at two different values of free stream Reynolds number, i. e., 0.33×10^6 and 1.65×10^6 per foot, corresponding to a completely laminar and fully developed turbulent surface boundary layer at the cone shoulder, respectively. The relationship between boundary layer properties and near wake properties is studied.			

Unclassified

Security Classification

14. KEY WORDS	LINK A		LINK B		LINK C	
	ROLE	WT	ROLE	WT	ROLE	WT
Hyperonic Flow						
Near Wake						
Laminar Wake						
Turbulent Wake						

Unclassified

Security Classification