

UNCLASSIFIED

AD 667 149

STATE OF THE ART IN DESIGN AND TESTING TO ENSURE
CONTINUED AIRCRAFT STRUCTURAL INTEGRITY

A. C. Larsen, et al

Boeing Company
Renton, Washington

1968

Processed for . . .

DEFENSE DOCUMENTATION CENTER
DEFENSE SUPPLY AGENCY



U. S. DEPARTMENT OF COMMERCE / NATIONAL BUREAU OF STANDARDS / INSTITUTE FOR APPLIED TECHNOLOGY

UNCLASSIFIED

AD 667149

45

STATE OF THE ART IN DESIGN AND TESTING TO ENSURE CONTINUED AIRCRAFT STRUCTURAL INTEGRITY

REC'D
APR 9 1966
REGISTRATION

A. C. LARSEN and R. E. WATSON

Structures Staff
The Boeing Company
Commercial Airplane Division
Renton, Washington

This document has been approved
for public release and sale; its
distribution is unlimited.

Presented at the Federal Aviation Agency Symposium
"Continued Reliability of Transport Type Aircraft Structures,"
FAA Headquarters, Washington, D.C., Nov. 2, 3, and 4, 1966

STATE OF THE ART IN DESIGN AND TESTING TO ENSURE CONTINUED AIRCRAFT STRUCTURAL INTEGRITY

A. C. LARSEN, Structures Staff
R. E. WATSON, Structures Staff
Commercial Airplane Division, The Boeing Company
Seattle, Washington

ABSTRACT

This paper reviews recent advancements in the design and testing of modern commercial jet aircraft structures as viewed by an American manufacturer. Advancements are continually being made in structural criteria, methods of analysis, materials and processes, structural testing, and the use of fleet experience. Each of these areas is discussed and examples are presented to show how these advancements are employed to ensure continued structural integrity of aircraft.

INTRODUCTION

The state of the art in structural design and testing is continually improving. However, over the last several years there have been particularly significant advances in design and testing to ensure continued safety in aircraft structures and to decrease structural maintenance with the goal of increased aircraft utilization.

What is the manufacturer doing in the art of design and testing to ensure structural integrity and to ensure that in-service structural maintenance will be within acceptable limits? Answers to this question, of particular interest to airline operators, are presented in a discussion of structural criteria, analysis methods, structural materials and processes, structural testing, and fleet experience.

STRUCTURAL CRITERIA

Many factors influence the structural design of an airplane. Probably the most important of these are the structural criteria, which establish the principal guidelines and requirements of the design. The thoroughness and exactness of such criteria will have a significant effect on the end product. Past airplane manufacturing experience has probably the greatest influence on the changes and improvements to the criteria, in particular to the detail requirements. Following are examples of the most important advances in structural criteria as practiced by The Boeing Company.

- **Single Pin Joints**
Single pin joints are now designed for rotation even though there is no relative motion intended. However, under load some relative motion does occur as a result of structural deflection, and corrosion in the joint has aggravated this condition. Bushings designed to allow relative motion are now specified for use in such applications.
- **Photostress Techniques**
Some structural elements in aircraft are extremely difficult to analyze as a result of the interaction of complex loadings and intricate structural connections, such as in a landing gear. The use of photostress techniques on plastic models is very helpful in defining stress patterns and is now specified in the detail criteria.

- **Corrosion Protection**
Fleet experience has shown that improvements in corrosion protection are required. As a result, new protective coatings and processes have been developed and are specified in the criteria.
- **Fatigue and Fail-Safe Criteria**
With the significant increase in utilization of jet as compared with propeller-powered aircraft and the higher static design stresses permitted by the use of new materials, fatigue and fail-safe criteria have taken on increased importance. Specific criteria are now being employed, including methods of analysis, more specific limitations on use of materials, and methods of obtaining improved fatigue quality based on past fleet experience.
- **Structural Bonding**
Although adhesive bonding has been used extensively in secondary structures, its use in primary aircraft structures in this country has been quite limited. Significant improvements in bonding have been developed over the last few years, and criteria are now being developed to cover primary structural applications. Specific controls of the bonding agents and processes are included in the criteria.

ANALYSIS METHODS

The high-speed computer has permitted the development of advanced methods for more precise analyses of aircraft structures. Loads, stresses, and deflections can be calculated more quickly and at many more locations than was previously possible. Many more loading conditions can also be evaluated. These more exact methods of analysis when properly applied will lead to more efficient structure and refinements in the detail design.

COSMOS

An example of the results obtained with one of these analysis methods, termed COSMOS

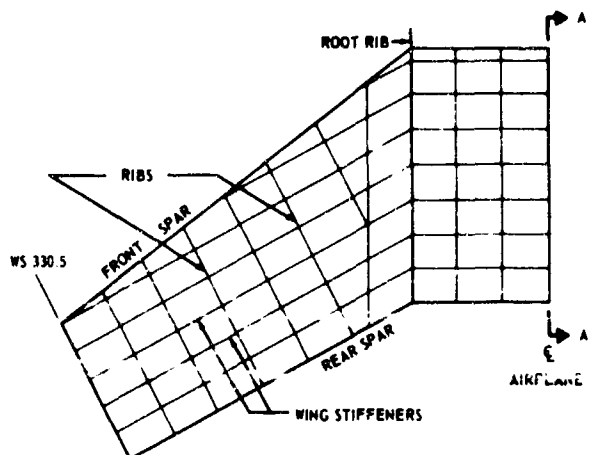

Figure 1 COSMOS Idealization of Root Section of 727 Wing

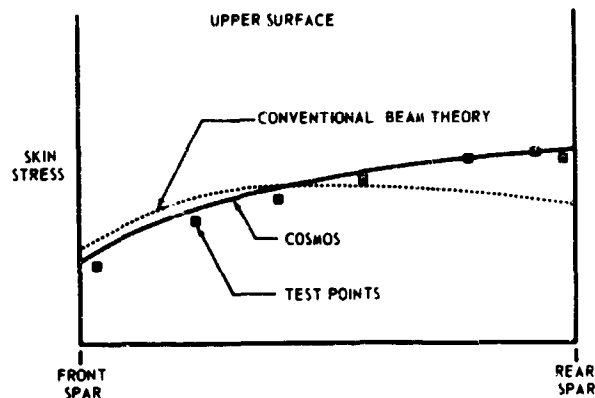

Figure 2 Section A-A Stresses

(Comprehensive Option Stiffness Method Organization System), as applied to the 727 airplane wing root (Fig. 1), is shown in Fig. 2. The analysis shows excellent agreement with stresses measured in static tests.

COSMOS, based on an energy analysis method, can be applied to any structure that can be simulated by an assembly of rods, sheets, plates, or beams. Extensive use has been made of this method and other computer methods in designing the structure of the 737 airframe (Fig. 3).

SEVERITY FACTOR METHOD

The accuracy of present fatigue analyses is much less than that of static and dynamic strength analyses. For example, calculations with errors of approximately 5 percent can be expected in static strength analyses, but fatigue analyses are quite often in error by 200 to 1,000 percent. For this reason extensive testing is usually conducted in conjunction with fatigue analyses.

To improve the accuracy of fatigue analyses, Boeing has been conducting research on methods that can readily be applied by designers to new structures being developed. One such method, termed severity factor method, embraces a calculation of a fatigue quality value called severity factor (SF) for mechanically fastened joints (Fig. 4).

For example, at a fastener hole the severity factor is expressed in terms of

- Load distribution in the joint, considering relative bypassing stress at the hole and relative load transfer at the hole.
- Three empirical factors that account for hole preparation (surface roughness and residual stress); fit of fastener in the hole; and fastener type, grip length, and single or double shear.

The load distribution is derived by an elastic solution, including the fasteners, in the members being analyzed. The three empirical factors are derived from small test specimens of various hole conditions and fastener installations. Figure 5 shows an analysis model suitable for computer analysis that was developed to simulate fastener behavior.

The severity factor method has been helpful in developing joints with optimum fatigue quality and in establishing fatigue criteria.

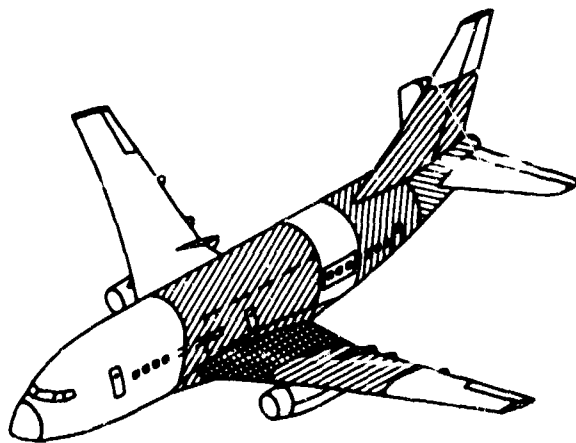

Figure 3 Areas of 737 Analyzed by COSMOS

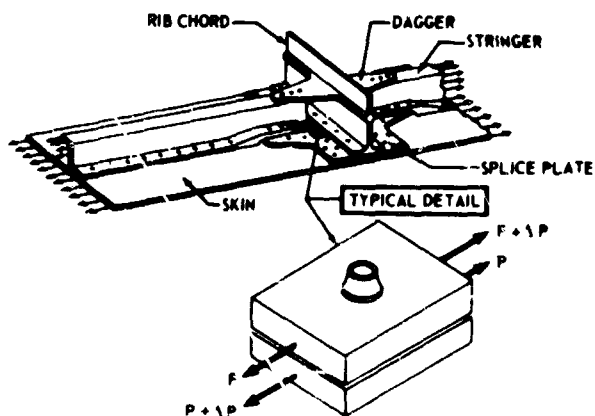

Figure 4 Severity Factor Analysis

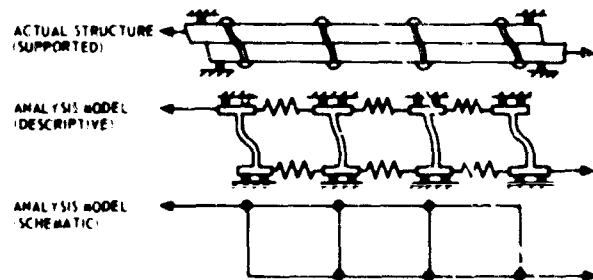

Figure 5 Severity Factor Analysis Models

It has also been used for comparing alternate design configurations. Figure 6 shows the load distribution calculated by this method for the original design of a structural joint. A characteristic of this structure is that the

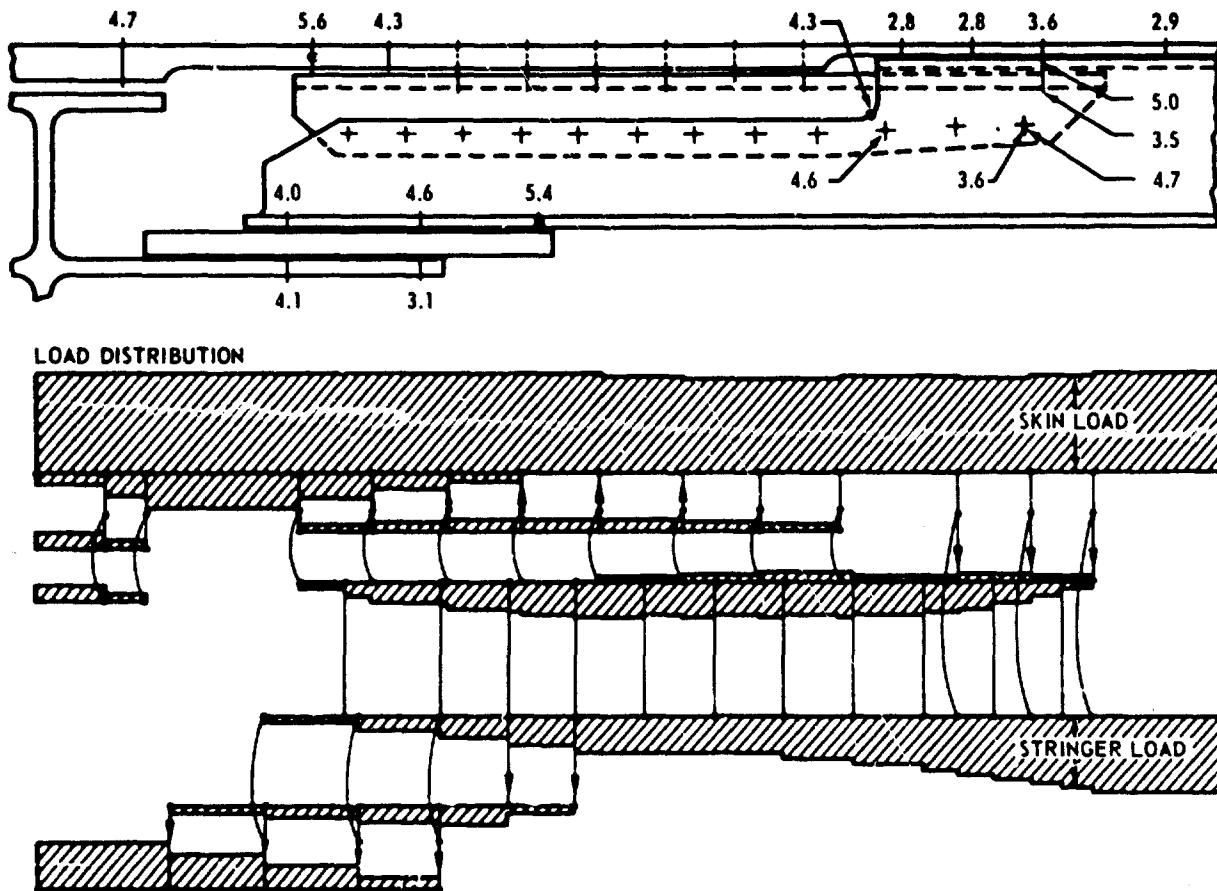

Figure 6 WBL 129 Original Design

skin is continuous while the stringer is spliced, utilizing the skin and the rib chord dagger as splicing members. Also shown are the severity factor values calculated at various locations. In-service fatigue cracking has occurred at the $SF \approx 5.6$ location. In laboratory fatigue tests, all the early cracks occurred at the $SF \approx 5.6$ location, as in service, except for the first crack in one panel, which occurred at the $SF \approx 5.4$ location.

Figure 7 shows similar calculations for a revised design of the same joint. Note that the load distribution is much better balanced, resulting in a minimum amount of load transfer between the skin and other members.

The revision reduced the largest SF value for the skin from 5.6 in the original design to 2.9 in the new design and the maximum SF value from 5.6 to 4.3. In laboratory fatigue tests, failures occurred at the $SF = 4.0$ location, but the fatigue life improvement of the new design was on the order of seven times that of the original design. Later refinements were made to the design that reduced the maximum SF value to 3.3.

STRUCTURAL MATERIALS AND PROCESSES

Today's transport aircraft are constructed of materials with static strength qualities well proven in service. Over the last de-

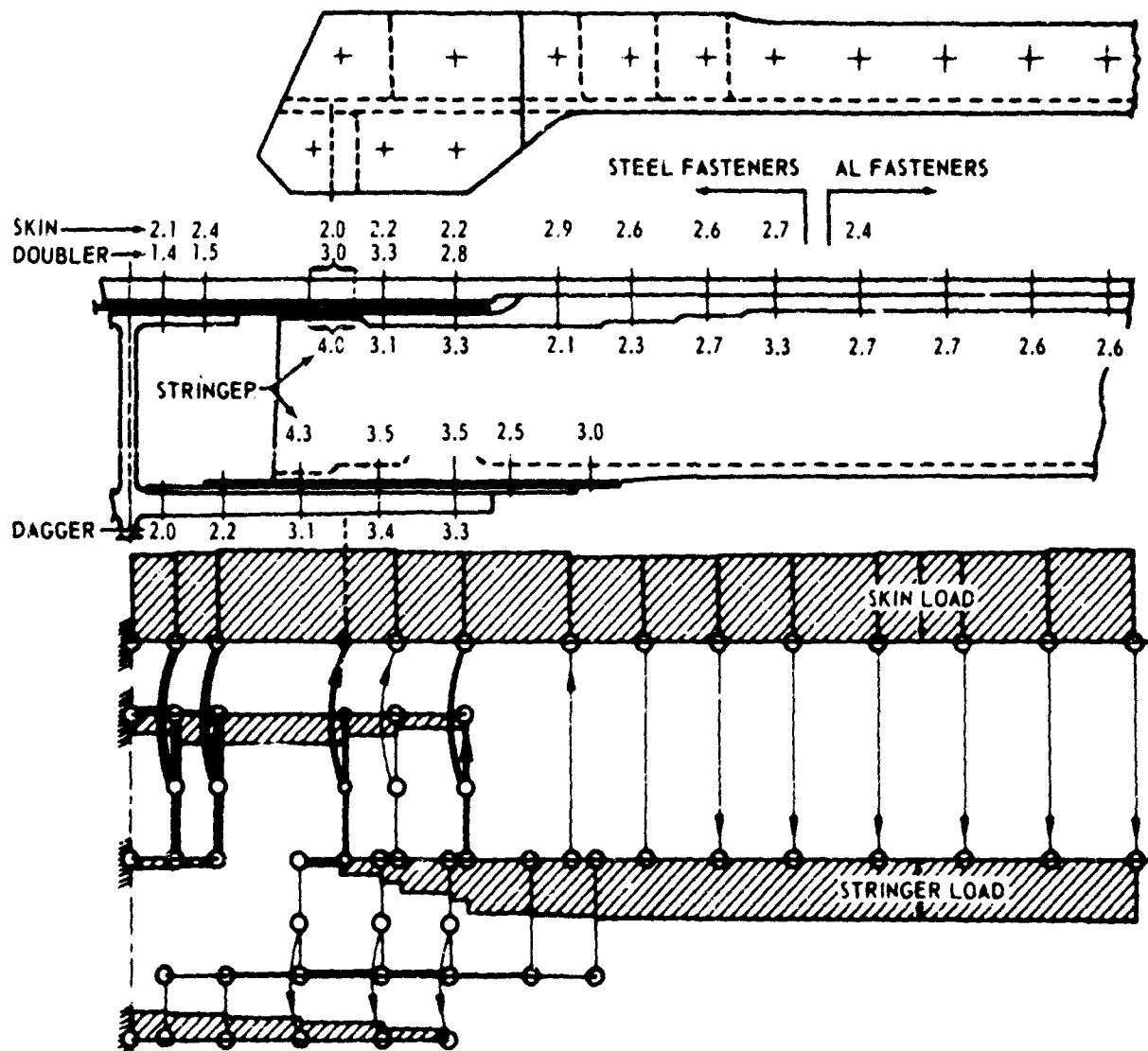

Figure 7 WBL 129 New Design

each, higher strength aluminum, steel, and titanium alloys have evolved that have permitted reduced structural weight and, consequently, more efficient structures. At the same time the capability of analyzing and using these higher strength alloys has advanced and is better understood. However, there are other characteristics of these materials that are not as well understood.

Equally important as static strength in the selection of a structural material are the

characteristics of fatigue resistance, crack propagation, fracture toughness, and corrosion resistance. The understanding of these properties and the methods of using them are advancing; however, a great deal of work remains to be done.

The static strengths of alloys are a function of the composition of the alloys. By experimenting with the chemistry of alloys, improved static strengths have been developed, but quite often at the expense of other desirable characteristics. For example, Boeing has found in the 7000-series aluminum alloy that although zinc and magnesium increase

its static strength, they decrease its fracture and fatigue properties. Similarly, the fracture toughness is sensitive to the amount of iron or silicon in the alloy. Figure 8 shows the effect of three alloying agents on the fracture toughness (G_c) of this alloy. The limits shown for 7178 represent the allowable tolerances of the alloying elements as established by present specifications. It is obvious, therefore, that there is a large possible variation in fracture toughness within the chemical composition range of this alloy.

Such large variations in fracture toughness in one aluminum alloy emphasize how difficult it is for the airplane manufacturer to accurately predict fatigue life. Boeing has suggested to the aluminum suppliers that they work on ways to tighten these tolerances or revise the chemistry. Although this work has not yet resulted in an improved 7178 alloy, it has provided insight into fracture rates and will lead to improved materials in future aircraft structures.

Although it is considered desirable for a structure to remain completely free of cracks or injurious defects throughout its life, this is not always possible nor practical. In nearly every machine in use today, failures may and do occur in service. The machines are usually repairable without significant loss in usefulness and after repair are generally considered completely acceptable. The challenge is to produce

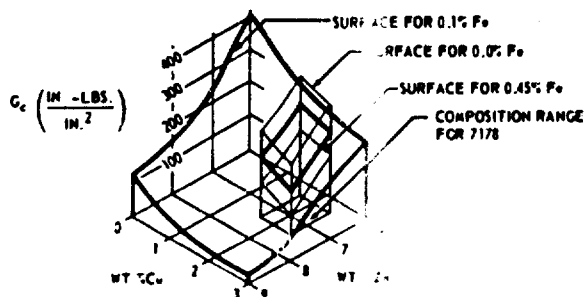

Figure 8 Fracture Toughness (G_c)

structures made of materials in which failures, should they occur, are safe and readily repairable.

In aircraft structures both safety and maintenance are extremely important. In the selection of materials, therefore, to ensure a high degree of safety and low maintenance, we must understand failure mechanisms and how to control them. Figure 9 shows results of testing to develop design data on the fracture toughness of aluminum alloy plate. Similar data are being developed on steel and titanium alloys for present and future transport structures. Figure 10 shows a

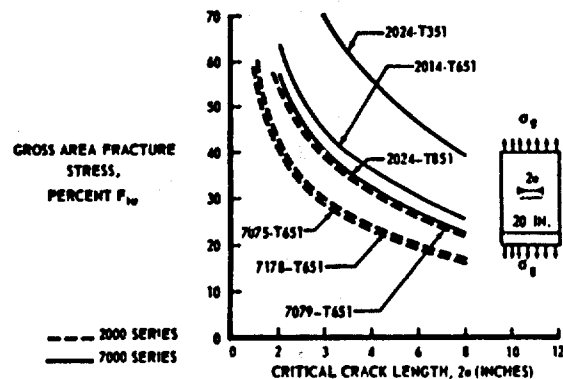

Figure 9 Fracture Toughness of $\frac{1}{2}$ -Inch-Thick Aluminum Alloy Plate

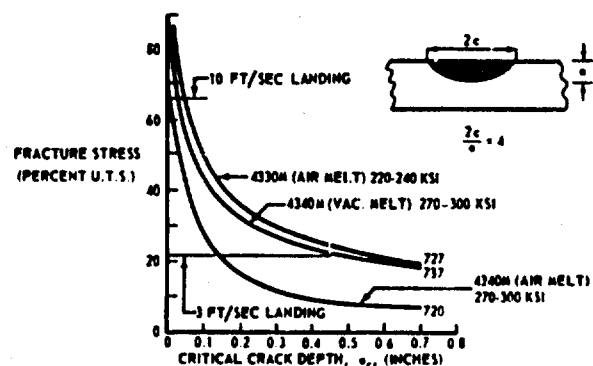

Figure 10 Fracture Stress-Steel

comparison of critical crack depths in both air-melt and vacuum-melt steels. Vacuum-melt steel is being used in the latest model transport structures to provide improved structural integrity with reduced structural weight.

Another important material property is corrosion resistance. Although significant improvements have been made in understanding corrosion, its effect and methods of control, it still exists as one of the maintenance problems on today's airplanes.

One corrosion problem of special interest is stress corrosion. The trend towards larger, stronger, and more intricate forgings in aircraft has resulted in stress-corrosion cracking caused by both internal stresses and service-induced stresses. In many cases, unsatisfactory exposed-grain conditions, combined with inadequate corrosion protection, result in corrosion cracking. To help solve this problem and reduce the maintenance burden for the operators, new forging processes have been developed. For example, ALCOA has developed a new thermal treatment for the 7075 forging alloy. This new alloy has been shown by tests to be highly resistant to stress-corrosion cracking, does not exfoliate, and is practically immune to intergranular corrosion. Figure 11 shows the results of tests comparing the new T73 alloy with the previous T6 material.

A number of improvements have been made in coatings for corrosion protection. Figure 12 lists some of the most recently developed coatings now being used in production. For example, epoxy primers have replaced zinc-chromate primers because they have greater resistance to chemicals and solvents and to abrasion, and they possess increased toughness. Polyurethane coatings provide much improved protection to fuel tanks from corroding agents such as water, salt, and microorganisms, as well as added protection against fretting corrosion. Similar improvements have been obtained from the other coatings listed in the figure and further improvements are continually being sought.

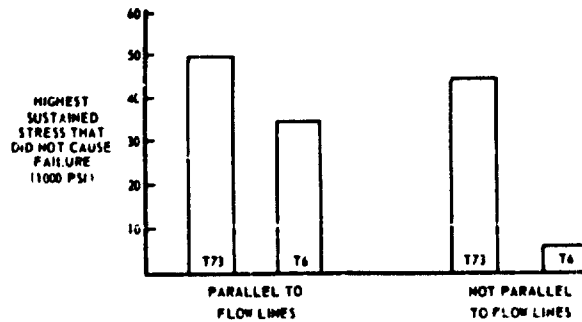

Figure 11 Stress-Corrosion Comparison

- EPOXY PRIMERS
- POLYURETHANE FUEL TANK COATINGS
- ALUMINIZED EXTERIOR COATINGS
- TEFLON FILLED POLYURETHANE ABRASION COATINGS
- POLYURETHANE EXTERIOR ENAMELS
- ANODIZED FINISHES FOR ALUMINUM
- CADMIUM-TITANIUM PLATING

Figure 12 Protective Coatings

The Boeing Company, as a reputable manufacturer, is vitally interested in obtaining superior performance from its products. Toward this end, material service failures, test failures, and manufacturing failures are carefully examined as they occur to determine the cause of failure and to establish corrective action. Material failure analysis commonly includes extensive optical fractography, microstructural evaluations, crack profile examinations, chemical analyses, mechanical property checks, and part histories.

The solution to a problem may be as serious as a design change or as simple as a minor alteration to a specification. Since an incorrect evaluation can prove expensive,

ways of improving failure analysis techniques are continually being sought. The Boeing Company has acquired a number of precision instruments and equipment to aid in material failure analysis.

One of these instruments is an electron microscope (Fig. 13), which is used in the examination of fractures by electron fractography. With its extensive depth of field and high magnification it is an excellent tool to aid in seeking the reasons for failure. Figure 14 shows photographs of service fractures, including an electron photomicrograph used to establish the fracture mode that could not be established by standard optical techniques.



Figure 13 Electron Microscope

Nonmetallic materials are being used more extensively in aircraft as improved bonding and manufacturing techniques are developed. Glass-fiber-reinforced resin composites are being used on secondary structural components because of improved fatigue performance, weight, and design simplicity. Utilization of composites on primary structures awaits development of a practical high-modulus composite system that does not sacrifice the advantages of proven composite materials.

Although there has been considerable publicity in recent years concerning boron filament composites, a great deal of research is required before they can be extensively used in aircraft. Some simple structures such as cylinders or shells have been produced using boron composites; however, there are many engineering and manufacturing problems to be solved. The Boeing Company has a government research contract to develop a helicopter rotor blade using a boron composite, which, along with other research being conducted, could lead to increased use of composites in future aircraft structures.

STRUCTURAL TESTING

Testing of aircraft structures is an integral part of the design development and substantiation program. Test specimens range from small material specimens to complete airframe components.

Many of the transports flying today were developed with major emphasis on static testing and with fatigue testing of only a select group of suspected critical locations. In recent years, however, the number of tests has increased substantially, with a greater emphasis on fatigue and fail-safe testing (Fig. 15). The reasons for increased testing are twofold. First, static tests are conducted as proof of strength, when analytical methods are complex or where strength verification is desired. Sec-

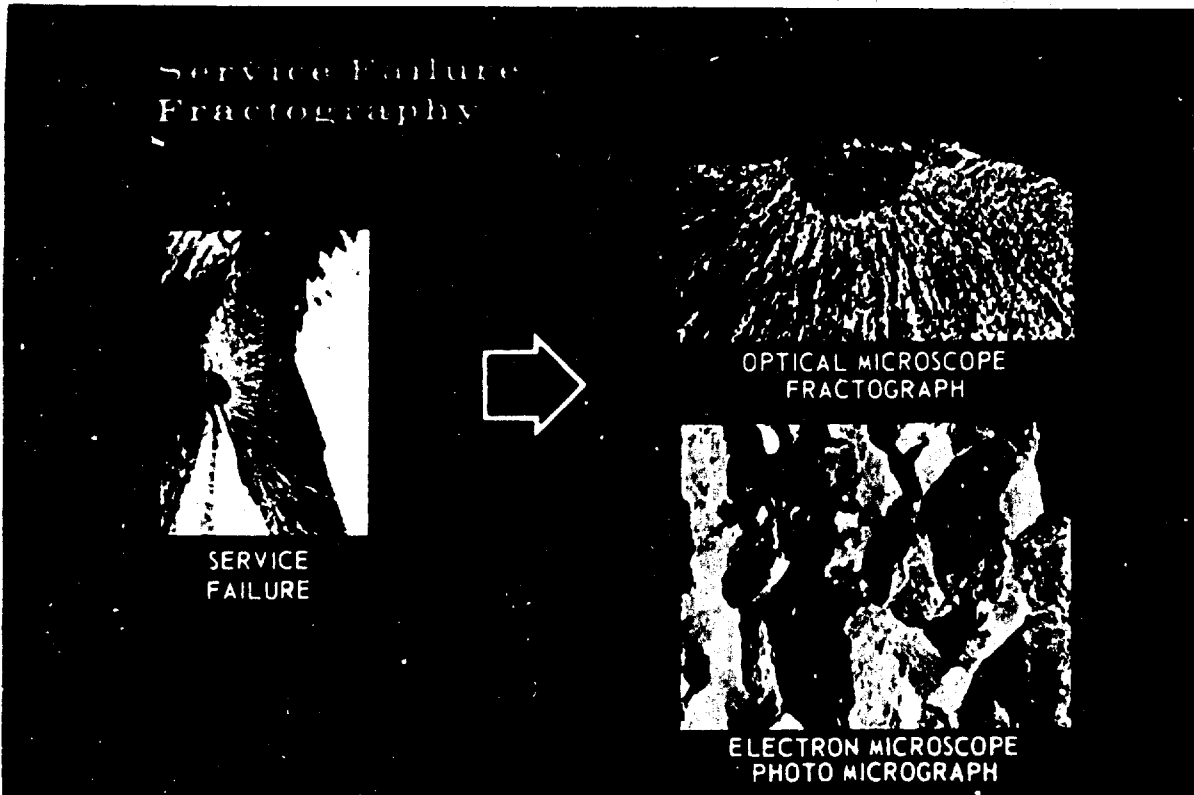

Figure 14 Service Failure Fractography

ond, static tests also provide data on airplane growth possibilities and increased structural efficiency. The inaccuracies of present fatigue analysis are such that extensive testing is required to ensure reasonable service life. (The lower total number of tests on the 737 airplane is the result of the smaller number of joints and the fact that many of the structural features are very similar to those of the 727.)

The Boeing 727 airplane was the first complete commercial airframe to be static and fatigue tested. Figure 16 shows examples of the fatigue failures developed during the test. Although a number of fatigue tests of suspected critical areas were conducted during the design development, the complete airframe test produced failures that otherwise would not have been detected until ex-

perienced in service. As noted on the figure, some of the changes that resulted were incorporated in the first production article and others were incorporated later in the production sequence. Inspection intervals and preventive modifications were established for those early aircraft not changed in production. The test has permitted a more orderly retrofit program than would have otherwise resulted. Crack propagation and fail-safe testing also has been conducted on structures with failed or partly failed elements as checks of analytical methods and as aids in establishing inspection intervals.

Included in normal development testing are corrosion testing, fastener tests, and other specialized tests such as photostress testing. This latter test uses plastic models and photostress techniques in developing

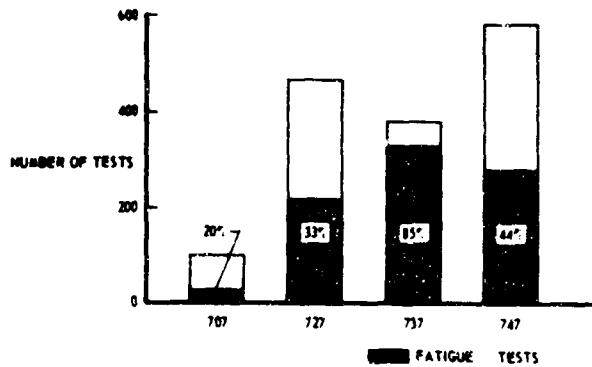

Figure 15 Laboratory Tests

complex structures such as landing gears (Fig. 17). Loads are applied to the model, areas of high stress concentrations are observed, and the gear structure is revised to eliminate or reduce potential trouble spots.

FLEET EXPERIENCE

Fleet experience information is of utmost value in ensuring continued structural integrity. Not only does this information call attention to potential problem areas of an existing fleet, but it is also an excellent source of information for use in new design.

As shown in Fig. 18, the Boeing jet family of commercial aircraft has amassed a total of nearly 8 million hours of flight to date. The high-time aircraft have now in excess of 30,000 flight hours, exceeding more than one-half of their original life objective. Some structural problems have arisen, changes have been incorporated in production, and preventive modifications have been established for the fleet.

To show the significance of fleet experience data, one has only to consider the fatigue

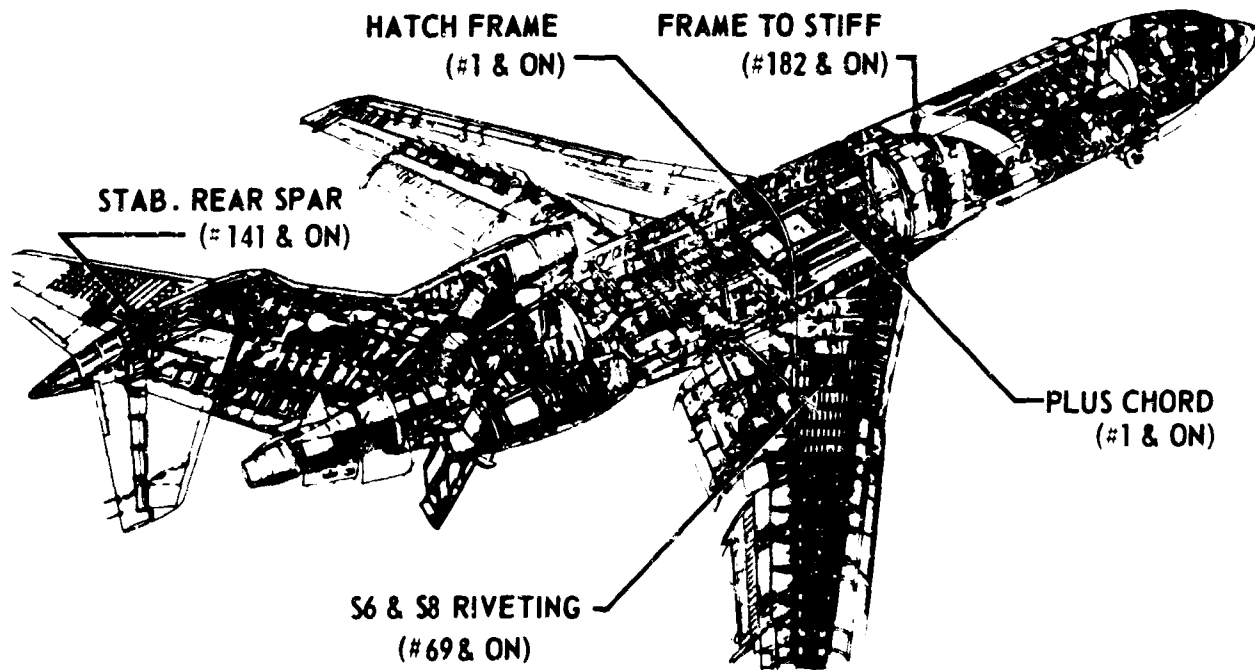

(# & ON) SHOWS AIRPLANE LINE POSITION WHERE IMPROVEMENT WAS INCORPORATED

Figure 16 Fatigue Failure Examples During 727 Airframe Fatigue Tests

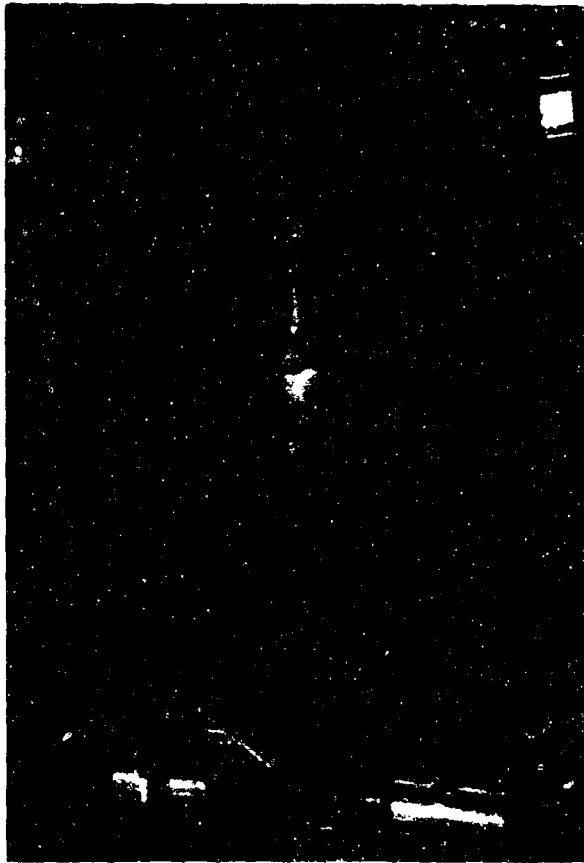

Figure 17 Photostress Testing of 737 Nose Landing-Gear Model

problem. With the present analysis methods, accurate estimates of structural life are difficult to achieve. As previously noted, it is not uncommon for life estimate analyses to be in error by a factor of 2 to 10. Fleet experience is the best information on which the designer can base estimates of structural life.

Boeing has and is using fleet experience, together with special high-time airplane inspections, structural teardown inspections, and the knowledge gained from fatigue testing, to evaluate the existing fleets and to design aircraft for the future. Figure 19 shows the results of a teardown inspection of a salvaged wing structure that had accu-

MODEL	FLEET HOURS	HIGH-TIME AIRPLANE HOURS
707	4,162,590	31,095 (CAL)
720	2,750,787	19,399 (UAL)
727	1,008,328	7,489 (EAL)
TOTAL		7,921,705

Figure 18 Boeing Commercial Jet Fleet Experience

LOCATION	TEARDOWN			HIGH-TIME AIRPLANE INSPECTION			
	FLIGHTS	STRUCTURE CRACKED	NO. OF CRACKS	FLIGHTS	STRUCTURE CRACKED	NO. OF APP'S CRACKED	NO. OF CRACKS
NBL 129 SPLICE	13000	SKIN	2	14000	SKIN	1	1
REAR SPAR CHORD & SKIN	↑	SKIN	1	↑	—	0	0
STOPPENER RIBOUT	↓	SKIN	1	↓	SKIN	2	3
WS 300 SPLICE	↓	SKIN	1	↓	SKIN	1	1
FUEL FILLER PITT'G WS 650	15000	SKIN	1	14000	—	0	0

Figure 19 Structural Inspection

mulated 25,000 hours of service time, and the correlation with three high-time airplane inspections.

A comparative fatigue analysis approach has been developed using fleet history information similar to that shown in Fig. 19. This approach encompasses the use of the four principal elements of the analysis life problems, as shown in Fig. 20. Design stress and fleet usage data are readily and accurately obtained from present analysis methods and a comprehensive assessment of the airplane usage. Fatigue quality is obtained by comparing laboratory fatigue test data on the critical structure. The items comprising the fourth element of this analysis are the greatest unknowns in fatigue analysis

- 1 DESIGN STRESS
- 2 FLEET USAGE
- 3 FATIGUE QUALITY
- 4 {
 - STRESS CYCLE
 - SCATTER FACTOR
 - TIME - CORROSION
 - SEQUENCE OF LOADING
 - OTHER

Figure 20 Fatigue Analysis Approach

and therefore have the largest effect on the accuracy of the results. Fleet experience provides this information, at least in total form, thereby reducing materially the possible error in the fatigue-life estimates. Fleet experience is thus most valuable in ensuring satisfactory structural life at a minimum expense of structural weight. With proper allowance for the difference in stresses and usage, one need only adjust the

existing fleet data by the application of the fatigue test quality correction to derive the life estimate at other locations or for a new structure. This method has been used successfully in predicting when difficulties may occur. It is also being used to establish production changes, inspection requirements, and preventive modifications.

Inspections of the structure serve two primary purposes: They provide a measure of safety and are an integral part of the structural maintenance program. The latitude of the inspections varies widely from a simple walkaround visual inspection to a detailed fastener or part-removal inspection using special optical or electronic equipment. The eddy-current instrument (Fig. 21) is one of the more common electronic inspection aids for detecting surface or near-surface defects.

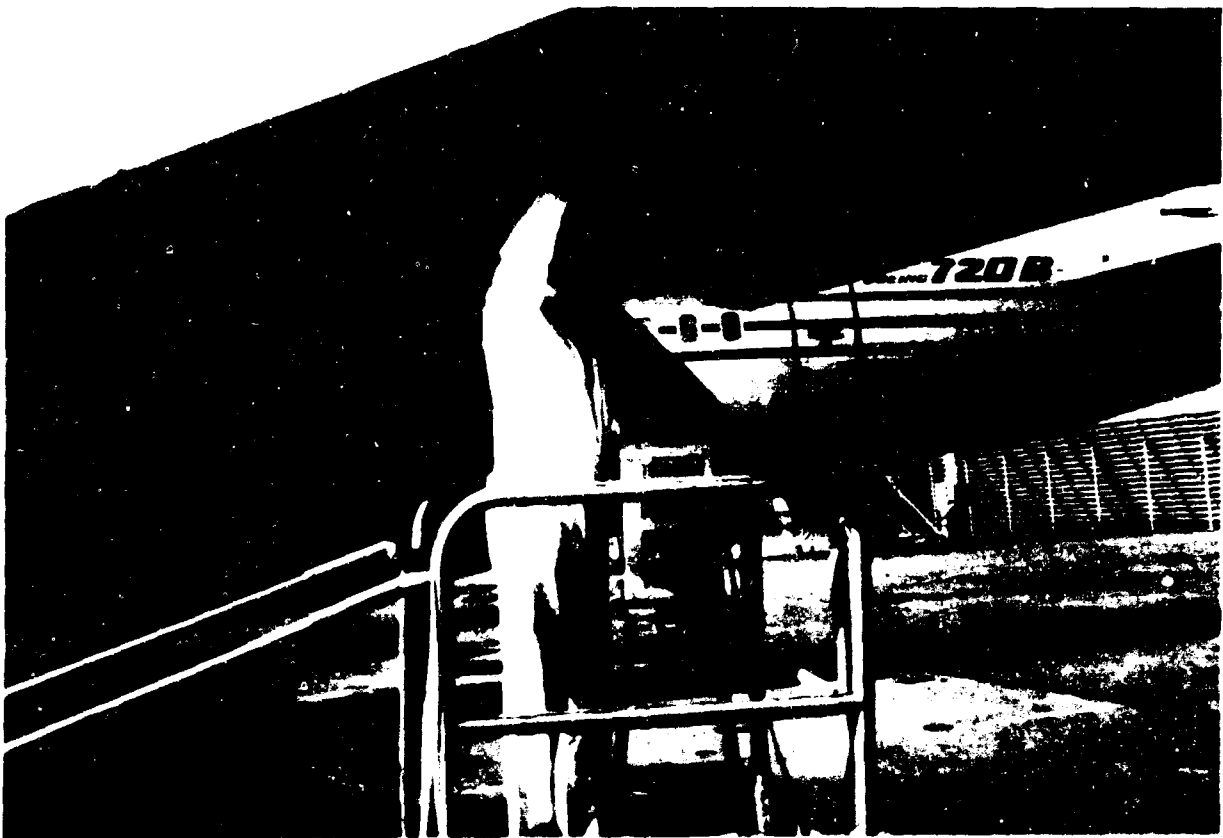

Figure 21 Eddy Current Inspection

Although no revolutionary developments in field inspection methods have occurred in the last several years, there have been some adaptations of existing methods that represent a measure of improvement in inspection methods.

One such adaptation is the use of a special ultrasonic shear wave probe for inspecting fastener holes without removing the fastener. Although it is only an adaptation of the ultrasonic method, the probe is a simple device that has been used successfully in special fastener-location inspections.

Another adaptation of an existing inspection method is the application of a small magnet, some Magnaglow, and an ultraviolet light to suspected critical details of a steel part. This technique has been used to make inspections without the time-consuming task of fastener removal.

The inspection aids described are examples of an airframe manufacturer's attempt to

provide, for service use, simple equipment for rapid inspections and a high degree of safety through prompt maintenance.

CONCLUSION

Of all the design tools and testing advancements used by an American manufacturer to ensure and improve aircraft structural integrity, probably the most important is fleet experience. There is certainly no better test than the actual service experience of several hundred airplanes by many different users.

Information received by the airplane manufacturer from the operators, accurately reported and properly integrated into improvements in production and in design of new structures, will provide future aircraft structures of the highest structural integrity.