

(4)

AD

AD 667988

USAAVLABS TECHNICAL REPORT 67-72

A STUDY OF THE VALIDITY OF GROUND-BASED SIMULATION TECHNIQUES FOR THE UH-1B HELICOPTER

By

J. H. Emery
W. G. O. Sonneborn
C. B. Elam

December 1967

**U. S. ARMY AVIATION MATERIEL LABORATORIES
FORT EUSTIS, VIRGINIA**

CONTRACT DA 44-177-AMC-463(T)

BELL HELICOPTER COMPANY

**A DIVISION OF BELL AEROSPACE CORPORATION
FORT WORTH, TEXAS**

This document has been approved for public release and sale; its distribution is unlimited.



Reproduced by the
CLEARINGHOUSE
for Federal Scientific & Technical
Information Springfield Va. 22151

D D C
RECEIVED
APR 16 1968
RECEIVED
C

Disclaimers

The findings in this report are not to be construed as an official Department of the Army position unless so designated by other authorized documents.

When Government drawings, specifications, or other data are used for any purpose other than in connection with a definitely related Government procurement operation, the United States Government thereby incurs no responsibility nor any obligation whatsoever; and the fact that the Government may have formulated, furnished, or in any way supplied the said drawings, specifications, or other data is not to be regarded by implication or otherwise as in any manner licensing the holder or any other person or corporation, or conveying any rights or permission to manufacture, use, or sell any patented invention that may in any way be related thereto.

Trade names cited in this report do not constitute an official endorsement or approval of the use of such commercial hardware or software.

Disposition Instructions

Destroy this report when no longer needed. Do not return it to the originator.

ACCESSION (or	
WPSTI	WHITE SECTION <input checked="" type="checkbox"/>
DOC	DOFF SECTION <input type="checkbox"/>
UNANNOUNCED	<input type="checkbox"/>
JUSTIFICATION	
.....	
BY	
DISTRIBUTION/AVAILABILITY CODES	
DIST.	AVAIL. and or SPECIAL
/	



DEPARTMENT OF THE ARMY
U S ARMY AVIATION MATERIEL LABORATORIES
FORT EUSTIS, VIRGINIA 23604

This report has been reviewed by the U. S. Army Aviation Materiel Laboratories and the Human Engineering Laboratories and is considered to be technically sound.

The work was performed under Contract DA 44-177-AMC-463(T) to study various kinds of simulators to determine their capability to produce data representative of visual flight for V/STOL aircraft. The resulting data were compared and correlated with flight data from the same aircraft. The simulators used different displays, motion modes, and instrumentation. The results presented in the report take the approach that a simulator is as faithful as its actual aircraft counterpart if the cross-correlation functions (aircraft motion versus control motion) and autocorrelation functions (aircraft and control motions at t_1 versus aircraft and control motions at t_1 minus lag) are identical.

The report is published for the dissemination and application of information and the stimulation of ideas in the area of simulation technology with emphasis on handling qualities research.

Task 1F125901A14233
Contract DA 44-177-AMC-463(T)
USAAVLABS Technical Report 67-72
December 1967

A STUDY OF THE VALIDITY OF GROUND-BASED
SIMULATION TECHNIQUES FOR THE UH-1B HELICOPTER

Bell Helicopter Report 299-099-350

By

J. H. Emery
W. G. O. Sonneborn
C. B. Elam

Prepared by

BELL HELICOPTER COMPANY

A Division of Bell Aerospace Corporation

Fort Worth, Texas

for

U.S. ARMY AVIATION MATERIEL LABORATORIES
FORT EUSTIS, VIRGINIA

This document has been approved
for public release and sale; its
distribution is unlimited.

SUMMARY

The work explored the characteristics of some simulator and flight data which were collected in a UH-1B helicopter and a ground-based simulated version of the same. Analytical treatments are described and applied to these data. They are auto-correlation and cross correlation functions, pilot error and pilot efficiency.

Two basic questions of simulation are considered. First, is the extent to which one can generalize or extrapolate upon the results of a simulator study to the actual system being simulated. The results of the study show that: (1) The aerodynamic characteristics of a given aircraft's flying qualities must be accurately represented in the ground-based simulator in order to produce a high correlation between a pilot's control behavior in the simulator and the aircraft. (2) Simulator motion in forward flight maneuvers is important when large attitude changes are required. In steady-state forward flight, platform motion is less important. (3) Simulator motion is helpful in hovering. Simulation of the offset of the pilot's seat with respect to the UH-1B helicopter center of gravity does not appear to produce better steady-state hover attitude control. In transition maneuvers, however, pilots reported that the c.g. offset was helpful. (4) The type of primary visual display that is included in ground-based simulators is very important. Maneuvers which require large attitude changes also require a wide display field-of-view.

The second question considers what events are important and how they should be measured in order to predict the usefulness of the system based upon the occurrences in the simulator. It was found that advantages of the various measurement techniques depend greatly upon what is to be emphasized from the data, such as control precision, pilot workload, lead-lag time constants, all of which are associated with the overall definition of handling-qualities problems.

Recommendations for further areas of research are presented in the report.

TABLE OF CONTENTS

	<u>Page</u>
SUMMARY	iii
LIST OF ILLUSTRATIONS	vi
LIST OF TABLES	ix
LIST OF SYMBOLS	x
I. INTRODUCTION	1
A. STATEMENT OF THE PROBLEM	1
B. BACKGROUND WORK	1
C. REASONS FOR THE PRESENT STUDY	2
II. PHYSICAL SYSTEM ELEMENTS	3
A. AIRCRAFT	3
B. GROUND-BASED SIMULATOR	7
III. DESCRIPTION OF DATA	19
A. OPERATING CONDITIONS	19
B. DATA ACQUISITION	20
C. DATA REDUCTION	21
IV. METHOD OF ANALYSIS	23
A. COEFFICIENT OF CORRELATION	23
B. CORRELATION FUNCTIONS	24
C. ERROR PARAMETERS	29
V. RESULTS	32
A. CROSS CORRELATION ANALYSIS	32
B. AUTOCORRELATION ANALYSIS	46
C. ERROR PARAMETER ANALYSIS	54
VI. CONCLUSIONS AND RECOMMENDATIONS	56
REFERENCES CITED	58
APPENDIXES	
I. DATA PROCESSING PROCEDURE	59
II. PROCEDURE FOR NORMALIZING AUTOCORRELATION AND CROSS CORRELATION FUNCTIONS	63
III. VALUES USED TO OBTAIN COEFFICIENTS OF CORRELATION	65
DISTRIBUTION	71

LIST OF ILLUSTRATIONS

<u>Figure</u>		<u>Page</u>
1	UH-1B Utility Helicopter	3
2	UH-1B Instrumentation Panel	6
3	Multiple-Exposure Photograph of Dynamic Simulator	9
4	The Pilot's Primary Display in the Ground-Based Simulator	11
5	Simulator Experimental Console	13
6	Roll and Pitch Handling-Qualities Boundaries as a Function of Damping and Control Power For UH-1B Helicopter and Simulator	14
7	Reaction to a Left Pedal Pulse for 95 Knots Level Flight for UH-1B Helicopter and Simulator	15
8	Reaction to a Right Pedal Pulse for 54 Knots Climb for UH-1B Helicopter and Simulator	16
9	Control Positions Versus Speed in Level Flight (Out of Ground Effect) for UH-1B Helicopter and Simulator	17
10	Example of Interpolation Procedure	21
11	Coordinate System of the Aircraft and Direction of Positive Control	27
12	The Meaning of the Four Quadrants for a CCF	27
13	Typical Example of a CCF	28
14	Illustration of Negative Time Shift - τ Between $f_1(t)$ and $f_2(t)$	29
15	CCF of the Roll Channel for the Acceleration Maneuver	32
16	CCF of the Pitch Channel for the Acceleration Maneuver	33
17	Pitch Oscillations During the Acceleration in Aircraft and Simulator	34

<u>Figure</u>		<u>Page</u>
18	CCF of the Pitch Channel for the Maximum Power Takeoff	35
19	Pitch Oscillations During the Maximum Power Takeoff in Aircraft and Simulator	35
20	CCF of the Roll Channel for the Maximum Power Takeoff	36
21	CCF of the Pitch Channel for the Steady Climb at 70 Knots	37
22	CCF of the Roll Channel for the Steady Climb at 70 Knots	37
23	CCF of the Roll Channel for the Steady Descent at 70 Knots	38
24	CCF of the Roll Channel for the Landing Approach	39
25	CCF of the Yaw Channel for the Landing Approach	40
26	CCF of the Pitch Channel for Hover Control .	43
27	CCF of the Roll Channel for Hover Control .	44
28	CCF of the Yaw Channel for Hover Control .	45
29	ACF of the Fore/Aft Stick Position For the Maximum Power Takeoff	47
30	ACF of the Fore/Aft Stick Position for the Steady-State Descent at 70 Knots	47
31	ACF of the Pitch Attitude for the Maximum Power Takeoff	48
32	ACF of the Pitch Attitude for the 70-Knot Descent	49
33	ACF of the Pitch Attitude for the Landing Approach	49
34	ACF of the Roll Attitude for the Maximum Power Takeoff	50

<u>Figure</u>		<u>Page</u>
35	ACF of the Roll Attitude for the Steady-State Climb at 70 Knots	51
36	ACF of the Roll Attitude for the Landing Approach	51
37	ACF of the Roll Attitude in Hover	52
38	ACF of the Lateral Stick Deflection in Hover	53

LIST OF TABLES

<u>Table</u>		<u>Page</u>
I	UH-1B Helicopter Description	4
II	Control Power and Relative Damping in Hover Yaw Channel	12
III	Flight and Simulator Maneuvers for Three Pilots	19
IV	Conditions of Hover Flight for Four Pilots .	20
V	Coefficients of Correlation for the Three Error Parameters for Simulator and Aircraft.	54
VI	Coefficients of Correlation for the Three Error Parameters for Two Types of Simulator Equations of Motion	55
VII	Flight/Simulator Correlation Study - Coding of Test Conditions	59
VIII	Flight/Simulator Correlation Study - Number of Sample Points for Each Test Condition . .	60
IX	Simulator Motion Study - Coding of Test Conditions	61
X	Instrumentation Oscillograph Records - Scale Factors for Time History Trace Deflections .	62
XI	Flight/Simulator Correlation Study - Scores Based Upon the Measurement $\sum e $	65
XII	Flight/Simulator Correlation Study - Scores Based Upon the Measurement $\sum(e w)$	66
XIII	Flight/Simulator Correlation Study - Scores Based Upon the Measurement $(\sum e) (\sum w)$. . .	67
XIV	Simulator Motion Study - Scores Based Upon The Measurement $\sum e $	68
XV	Simulator Motion Study - Scores Based Upon The Measurement $\sum(e w)$	69
XVI	Simulator Motion Study - Scores Based Upon The Measurement $(\sum e) (\sum w)$	70

LIST OF SYMBOLS

OGE	out of ground effect
rev.	revolution
c.g.	center of gravity
MIL	military
alt.	altitude
T	total length of record in sec
t	time as independent variable in sec
r	time shift in sec
$f_i(t)$	i'th function of time, $i = 1, 2$
$\overline{f(t)}$	time average of $f(t)$
$\overline{f^2(t)}$	time average of $ f(t) ^2$
N	number of samples in T, equally spaced
t_i	time $t = i$, $i = 1, 2, \dots, N$
r_j	time shift $r = j$, $j = 1, 2, \dots, M$; $M \leq N/10$
$ e $	momentary absolute attitude error at t_i
w	momentary control rate at t_i
$\Sigma e $	$ e $ summed over N
$\Sigma(e w)$	$ e $ times w summed over N
$(\Sigma e) (\Sigma w)$	$ e $ summed over N times w summed over N

SECTION I. INTRODUCTION

A. STATEMENT OF THE PROBLEM

This study was conducted in order to determine the validity of ground-based simulation techniques for the UH-1B helicopter. The task of assessing how well the aircraft's handling-qualities can be simulated was approached by comparing certain simulator variables (equations of motion, platform motion and flight maneuvers) and certain performance variables (cross correlation, autocorrelation, pilot errors and pilot efficiency). The emphasis of the study was to determine how effective a ground-based simulator can be used to predict a known aircraft's handling-qualities and from this to be able to predict new design concepts, which are not known, from simulator results. The approach was to determine the correspondence between fidelity of simulation (how closely the simulator looks and behaves like the aircraft being simulated) and validity of simulation (how well the simulator predicts what will happen in the aircraft).

The problem of quantifying pilot performance was also studied. Since there is no absolute criterion on which to establish pilot performance, the task of predicting how well a simulator simulates an aircraft is concerned with describing a function in which neither the independent variable (fidelity of simulation) nor the dependent variable (pilot performance) is known with a high degree of precision. The reliance upon "face validity" for the first and "pilot's opinion" are unsatisfactory indices for many situations.

The exploration made in the present study was into some of the alternatives to subjective evaluation. The nature of the study was to prepare a critique of the "quality" of a helicopter simulation technique. The data used for the present analysis were originally collected for other programs, but were also capable of being used for making handling-qualities comparisons between the UH-1B helicopter and a ground-based simulator version of the same.

B. BACKGROUND WORK

The use of ground-based simulators at the facility where these data were collected has been principally for conducting helicopter instrumentation evaluations. The main contribution of including motion in the simulator for these studies was to provide an additional means of "alerting" the pilot. The usefulness of motion was confirmed by Feddersen (Reference 1) in a series of studies where hover data were collected in the simulator with and without the dynamic platform in motion. He correlated these data with hover data collected in flight.

The results of this series of studies showed that when motion was included in the simulator the pilot's control inputs were more closely correlated with their flight control inputs than when the simulator was controlled without motion. These conclusions were arrived at on the basis of one set of equations specifically designed for the hover case. Simulator motion was studied by comparison of hover flights with four-degrees-of-freedom platform motion which included pitch, roll, yaw, and heave, against no motion.

C. REASONS FOR THE PRESENT STUDY

If ground-based simulators are to be used for handling-qualities research, transition maneuvers and forward flight need to be simulated in addition to the hover mode. Several questions need to be answered for these flight regimes where physical restrictions are imposed upon ground-based simulators. This study was designed to answer the following questions:

- Equations of Motion - Is a set of linear equations adequate or must nonlinear representations of the equations be chosen? Feddersen's hover work was restricted to linear representations.
- Transitional and Forward Flight - In the hover case the simulator motion can be the same as in the aircraft since the excursions are within the limitation of the simulator platform motion capability. In forward flight simulator motion must be different from that of the aircraft. How should motion be represented in the simulator when forward flight of the aircraft is simulated?
- Platform Motion - What is the effectiveness of intermediate levels between no platform motion and full platform motion?
- Prediction Measurements - The ultimate functions of research simulators are to be predictors. Are there different means of measuring pilot performance and control to increase the reliability of predictions from simulator findings?

SECTION II. PHYSICAL SYSTEM ELEMENTS

A. AIRCRAFT

1. DESCRIPTION

The aircraft was a UH-1B helicopter (see Figure 1). It is a utility-type aircraft with a single, two-bladed rotor powered by a T-53 gas turbine engine. The flight characteristics of this helicopter in general are similar to those of other single-rotor helicopters. A particularly noticeable difference is the additional stability that is evident in all flight regimes resulting from gyroscopic action of the stabilizer bar.



Figure 1. UH-1B Utility Helicopter.

2. UH-1B HELICOPTER DATA TABLE

A description of the UH-1B helicopter is found in Table I.

TABLE I. UH-1B HELICOPTER DESCRIPTION

<u>General</u>	
Design Gross Weight	6500 lbs
Normal Crew	2
Overall Length	38.4 ft or 460.85 in.
Max Ground Attitude (tail low)	10.5°
Roll Mass Moment of Inertia (including rotor)	2780 slug-ft ²
Pitch Mass Moment of Inertia (including rotor)	9300 slug-ft ²
Yaw Mass Moment of Inertia (including rotor)	7500 slug-ft ²
<u>Main Rotor</u>	
Type	seesaw
Diameter	44.0 ft
Number of Blades	2
Blade Chord	21.0 in.
Blade Weight	382.5 lbs
Airfoil Section	NACA 0012
Blade Taper	0
Blade Twist (root to tip)	-10.0°
Hub Precone	2.5°
Disc Area	1520.5 ft ²
Disc Loading	4.275 lb/ft ²
Solidity	0.0506
Normal Operating Speed	324 RPM
Normal Tip Speed	718.8 ft/sec
<u>Stabilizer Bar</u>	
Diameter	9.03 ft
<u>Tail Rotor</u>	
Weight per Blade	14.75 lbs

TABLE I - Continued

<u>Tail Rotor - Continued</u>	
Diameter	8.5 ft
Number of Blades	2
Blade Chord	8.41 in.
Hub Type	seesaw
Airfoil Section	NACA 0015
Blade Twist (root to tip)	0
Delta-Three Hinge	45°
Disc Area	56.75 ft ²
Solidity	0.0525
Normal Operating Speed	max = 1641 RPM
<u>Horizontal Stabilizer</u>	
Span	9.33 ft
Chord	1.833 ft
Airfoil Section	NACA 0015
Platform	rectangular
Aspect Ratio	5.11
Area	17.16 ft ²
Incidence Angle	-4.5°
<u>Vertical Stabilizer</u>	
Span	4.25 ft
Chord (tip)	23 in.
(root)	45 in.
Area	10.4 ft ²
Taper Ratio	0.512
Aspect Ratio	1.3
Airfoil Section	-
<u>Powerplant</u>	
Type	T53-L-11
Max Power (takeoff)	1100 HP
MIL Power (30 min)	1000 HP

3. COCKPIT

A photograph of the UH-1B instrumentation panel is shown in Figure 2. Dual controls and primary flight instruments are provided.

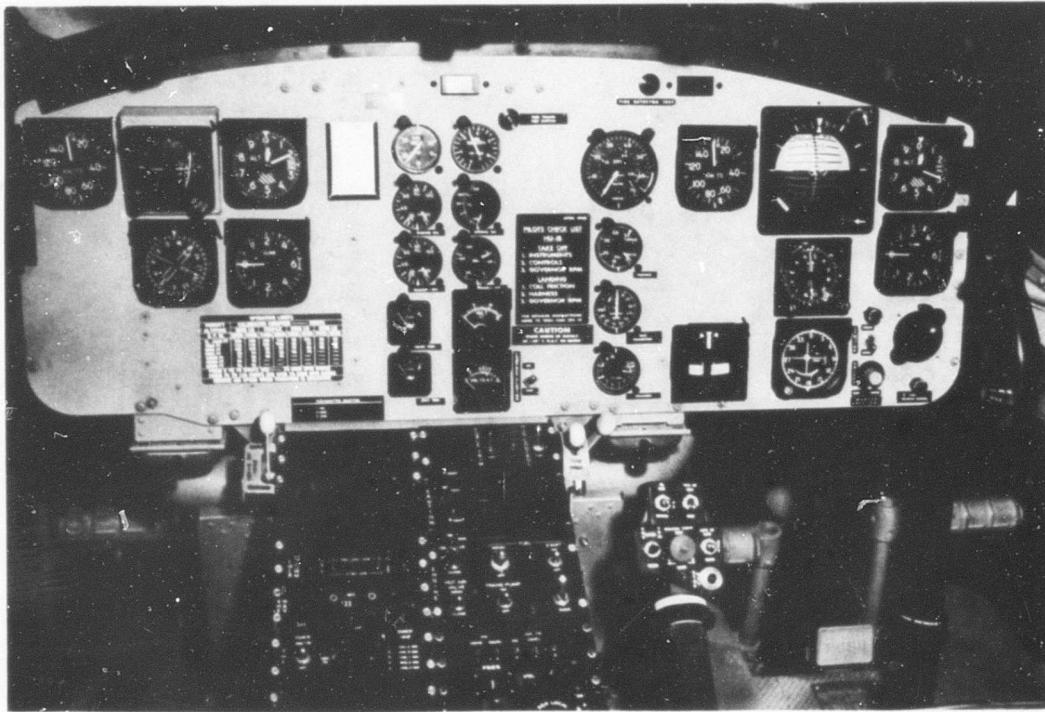

Figure 2. UH-1B Instrumentation Panel.

4. FLIGHT CONTROL SYSTEM

The flight control system is a mechanical type, actuated by conventional helicopter controls. The system includes cyclic control stick, used for fore/aft and lateral control; the main rotor collective pitch control lever, used for main rotor thrust control; tail rotor control pedals, used for directional control; and a synchronized elevator, used to increase controllability and to lengthen the c.g. range.

a. Force Trim

The control forces of the flight control system are reduced to a near-zero-pounds force by feedback-free hydraulic boost cylinders. Force trims (force gradient) connected to the cyclic and directional controls are used to induce artificial control feeling and to prevent the cyclic stick from moving of its own accord. A force trim switch is installed on the cyclic

grip which enables the pilot to trim the controls, as desired, for any condition of flight. Without the force-centering device, the pilot's controls are, for all practical purposes, not rate limited, due to the low time constants of the hydraulic boost systems (0.08 second). For example, full throw of the cyclic stick (12 inches) can be accomplished within one second without a noticeable feedback force from the boost system. Desired operating friction can be induced into the control lever by hand-tightening a friction adjuster.

b. Stabilizer Bar

The stabilizer bar is attached to the main rotor mast above and at a 90-degree angle to the main rotor blades. The inherent inertia and gyroscopic action of the bar are induced into the rotor system and produce a measure of stability for all flight conditions. Two nonlinear hydraulic dampers provide damping forces that make the stabilizer bar follow the ship, thus providing a desired amount of stability that does not adversely affect the response of the helicopter after a pilot's control input.

B. GROUND-BASED SIMULATOR

1. DESCRIPTION

The ground-based simulator at Bell Helicopter Company can best be described in terms of the major components which make up the simulation facility.

a. The Dynamic Platform

The dynamic platform is a hydraulically actuated, servo-controlled system which is capable of moving in six degrees of freedom. With regard to the limits of travel, the simulator is capable of pitching within the limits of $\pm 10^\circ$ with a maximum velocity of $16^\circ/\text{sec}$ and a maximum acceleration of $40^\circ/\text{sec}^2$. The roll response also occurs within $\pm 10^\circ$ with a maximum velocity of $17^\circ/\text{sec}$ and a maximum acceleration of $60^\circ/\text{sec}^2$. The third angular response, yaw, also occurs within the limits of $\pm 10^\circ$ with a maximum velocity of $10^\circ/\text{sec}$ and a maximum acceleration of $15^\circ/\text{sec}^2$.

Although the simulator is capable of the three translational motions of heave (vertical), surge (longitudinal), and sway (lateral), the latter two are used primarily as compensatory motions to reproduce with greater fidelity the pitch and yaw responses of an aircraft with offset axes of angular motions (c.g. offset from cockpit center). Consequently, of the three translational motions, heave is the only channel over which the pilot has independent control. The limits of vertical travel within which the dynamic platform operates are

approximately ± 3.5 feet, or an overall travel of 7 feet. Within these limits, the maximum velocity attainable is 6.6 ft/sec with a maximum acceleration of 6.5 ft/sec².

In addition to the basic travel limits described, provisions are made for safety in the event of overtravel in each degree of freedom. Under normal flight conditions, the overtravel zone is seldom entered; however, during certain maneuvers it is possible to force the platform into the overtravel region of motion in any degree of freedom. When the platform enters this zone, it is slowed to a stop hydraulically; thus it is prevented from banging against the stops. Figure 3 is a multiple-exposure photograph showing the movement limits of the platform in vertical and lateral displacements.

b. Analog Computer and Equations of Motion

Operation and control of the simulator and display generation system were accomplished through a Berkeley EASE Model 1000 electronic analog computer. This equipment, which has the necessary flexibility for the solution of equations of motion for a number of vehicular systems, both ground and airborne, includes 327 amplifiers, 40 integrators, 34 servo multipliers, 2 function generators, 4 electronic multipliers, and three 3-channel Sanborn pen-recorders. In addition to providing a permanent record of performance data, these recorders were also utilized in the initial check out of the equations of motion and in daily calibration procedures.

The equations of motion used in this study were programmed on the computer to provide driving signals for the servo motors of the display generator and the hydraulic servos of the simulator platform.

The equations of motion used were synthetic equations. Forces and moments were not computed from basic aerodynamics, but a curve-fitting process to flight test results was used. As an example, the magnitude of the main rotor thrust vector in hover was simply a linear function of collective stick position modified in forward flight for the speed effects. Presentation of the static trim values and the dynamic responses produced by these equations are shown later in this section and are considered to be more meaningful than a detailed description of the computer block diagram, linkage ratios, scale factors, etc.

c. Control System

The simulator cockpit was equipped with conventional helicopter controls consisting of cyclic stick, yaw pedals, and collective pitch lever. The controls were conventional in configuration, placement, and function. Unlike the aircraft, no provisions for force trim centering were available in the

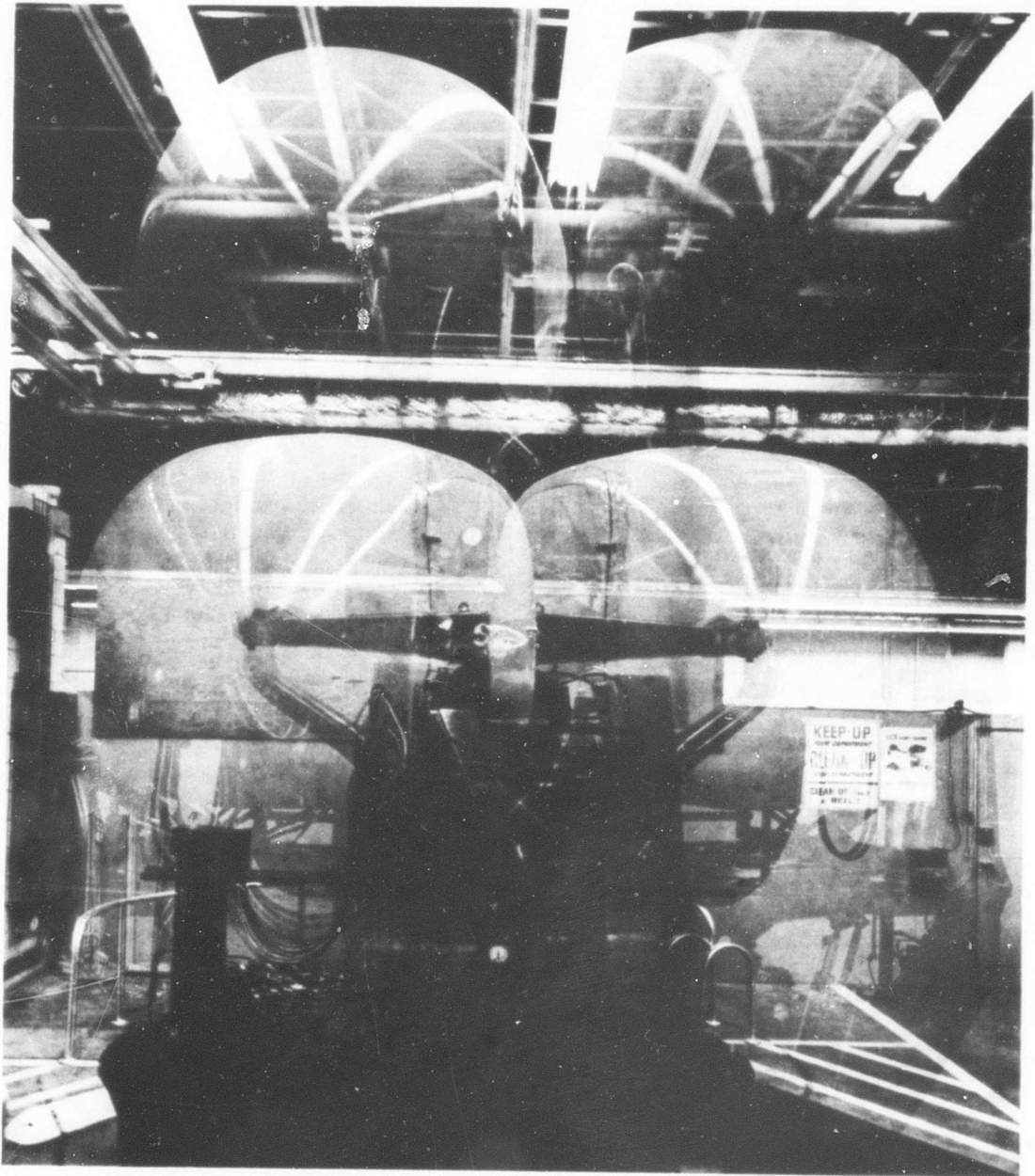

Figure 3. Multiple-Exposure Photograph of Dynamic Simulator.

simulator. However, the desired operating friction could be induced by hand-tightening a friction adjuster.

Control deflection ranges were identical to those of the flight vehicle. The cyclic control full range of travel at the middle of the grip in the fore/aft (pitch) and lateral (roll) directions was 12 inches. The overall travel of the foot pedals from one extreme to the other was 6.5 inches. The collective pitch control lever was mounted at the base of the cabin seat to the left of the pilot. The full range of travel from full-down to full-up measured 12 inches.

d. Visual Display and Instrumentation

The pilot's primary visual display is shown in Figure 4. The information viewed on the screen gave a perspective of cues similar to what would be seen if the pilot were looking through a window at the real world. A visual angle of 30 deg was subtended. An artificial horizon was seen to separate a ground plane and a sky texture. In addition to the basic pitch and roll attitude information conveyed by the horizon line, the ground plane consisted of grid lines which moved in the fore/aft and lateral directions to simulate the perspective of translation over the ground. The grid also rotated to indicate yawing motions and changed in separation to simulate height above the ground. Within the one display could be viewed an integrated pictorial image of the six rigid-body degrees of freedom. This technique for pictorially integrating separate flight information into one visual display is known as the contact analog concept. (Reference 2)

The use of the contact analog, as the pilot's primary visual display in the ground-based simulator, provides much of the visual information that is found in television displays. Since the original purpose of the simulator described in this report was to conduct helicopter instrument display evaluations, no primary visual display as such was specified to be used in conjunction with the simulator.

While the display lacks complete agreement with the real world in such features as total field of view, depth, texture and color, other important visual cues such as the spatial geometry and movement relationships may be viewed in complete agreement.

For the present analysis, the data collected in the ground-based simulator represents flights in which the contact analog was the pilot's primary display. In the helicopter, the data represents flight maneuvers performed under contact visibility only.

The visual information obtained from the display was augmented with meters mounted adjacent to the primary visual display, which presented airspeed, altitude, and power indications.

In addition to the displays and controls, several other features were provided to simulate the aircraft. One was cockpit vibration. Attached firmly to the bulkhead of the cockpit was an electric motor which rotated two eccentric weights. These weights were rotated at 10 cps and 5 cps to reproduce the one- and two-per-rev vibration characteristics of two-bladed, single-rotor helicopters. Since the motor was firmly attached to the cockpit, the vibrations generated by the offcenter weights were transmitted to the pilot through the cockpit structure.

Once the cockpit door was firmly closed, the pilot had no external visibility and was required to use a headset to communicate with the controller at the experimental console. Air-conditioning was provided to maintain a comfortable cabin environment throughout the simulated flights.

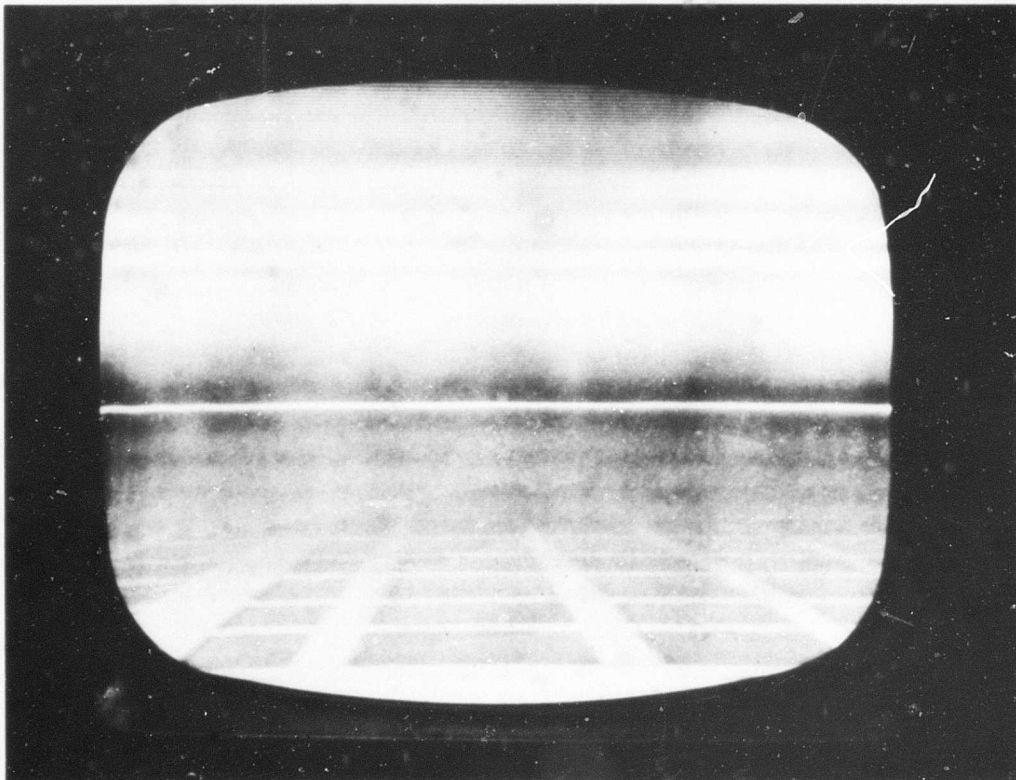

Figure 4. The Pilot's Primary Display in the Ground-Based Simulator.

e. Experimental Console

All components of the system were controlled from an experimental console. In addition to a TV monitor, this station also contained an interlock circuit that allowed a master control switch to be effective only when all components of the system were ready for a given trial to begin. The experimental console is shown in Figure 5.

2. FLIGHT CHARACTERISTICS

a. Hover

Figures 6a and 6b give control power and damping characteristics of the aircraft and simulator, mapped in the charts of Reference 3.

For the yaw channel, the values are given in Table II because the corresponding chart of Reference 3 is believed to be inapplicable.

TABLE II. CONTROL POWER AND RELATIVE DAMPING IN HOVER YAW CHANNEL		
	UH-1B	Simulator
Relative Damping	.95	1.0
Relative Control Power	.45	0.53

b. Level Flight Characteristics

One example of the dynamic responses of the simulator and aircraft in level flight is shown in Figure 7.

c. High-Power Climb Characteristics

Figure 8 shows a comparison of roll rate and yaw rate to a pedal pulse in simulator and aircraft.

d. Control Position Plots

Figure 9 shows fore/aft stick position versus speed in level flight.

From Figures 6 through 9, it is evident that the mathematical model used for the simulation was quite satisfactory.

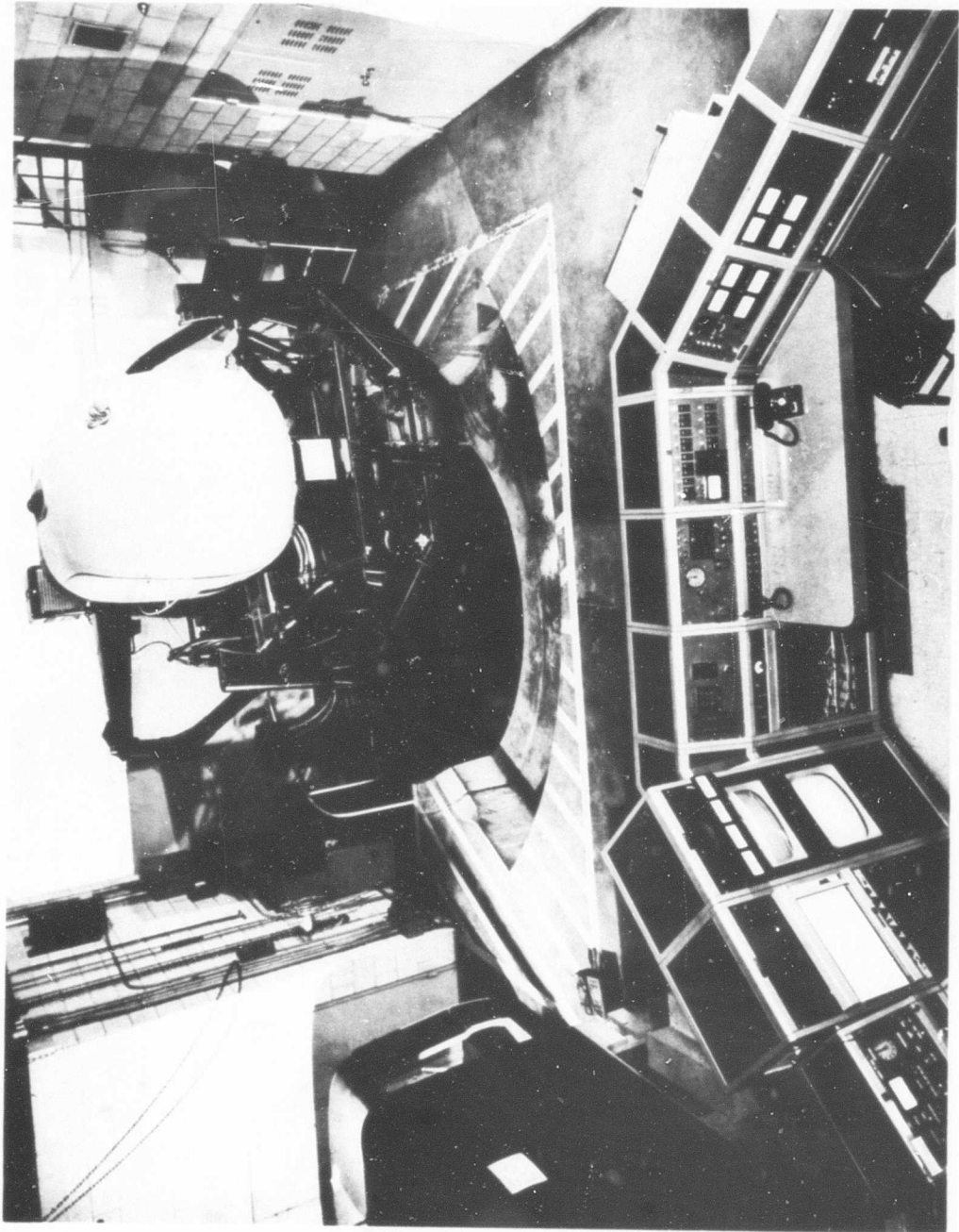

Figure 5. Simulator Experimental Console.

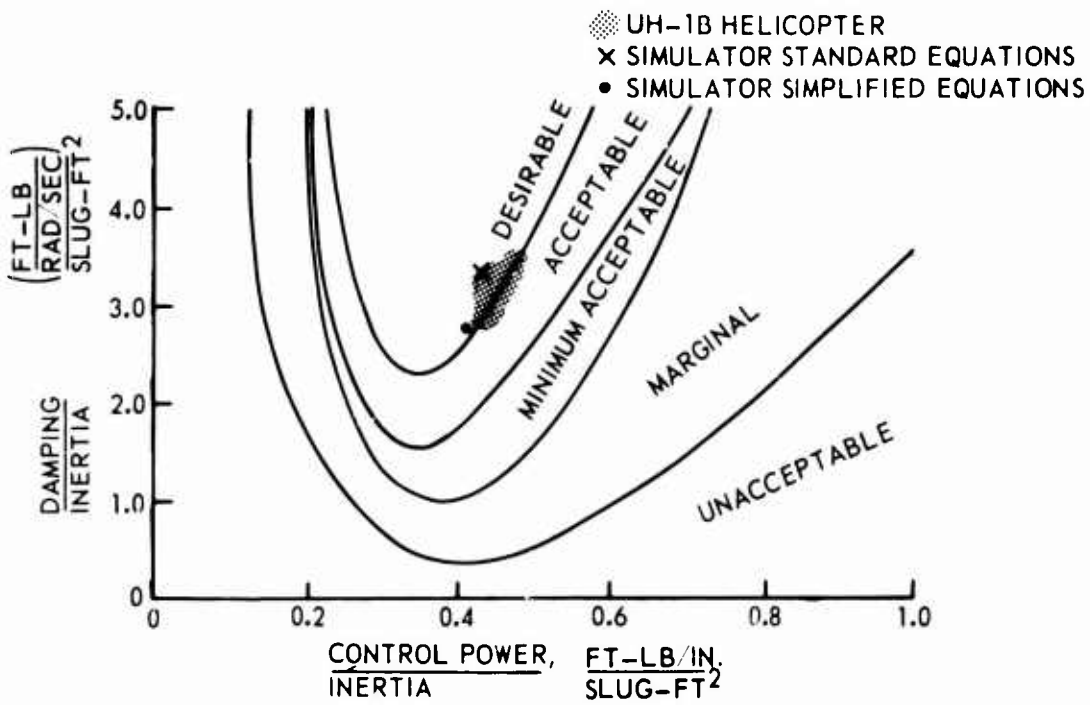
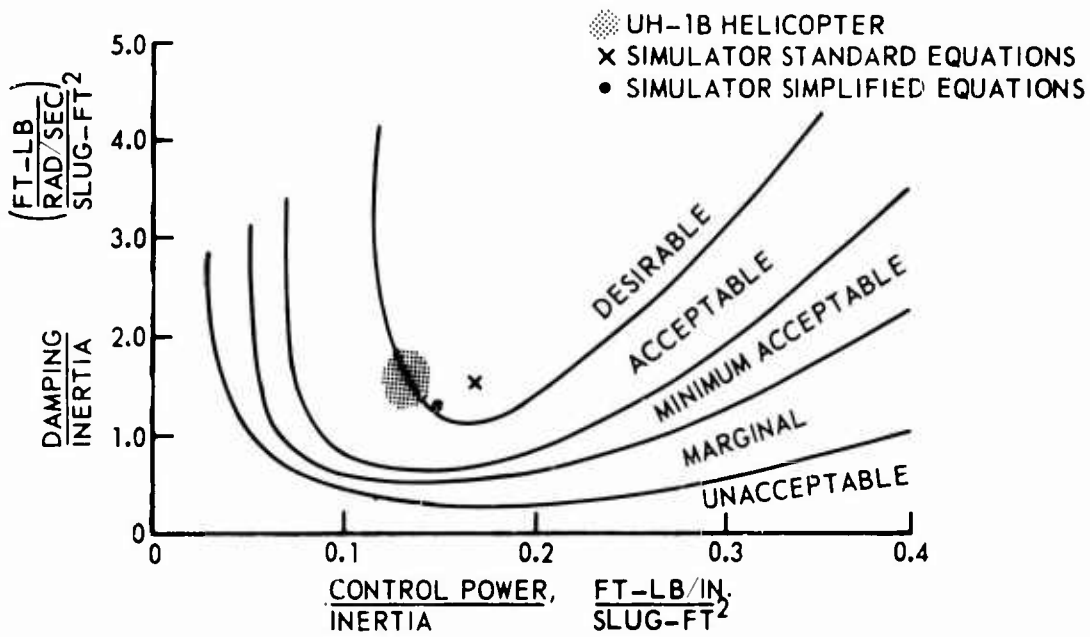

Figure 6. Roll and Pitch Handling-Qualities Boundaries as a Function of Damping and Control Power for UH-1B Helicopter and Simulator.

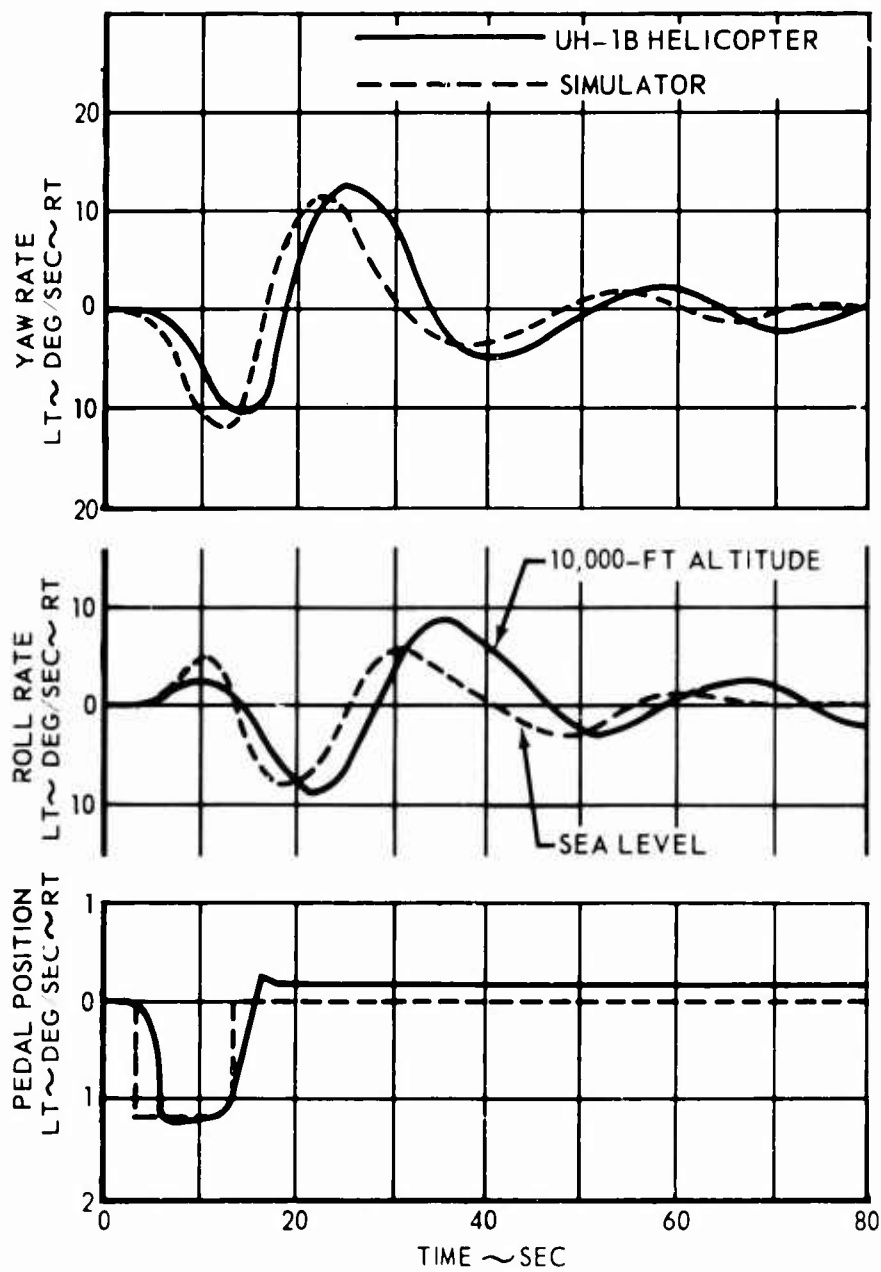

Figure 7. Reaction to a Left Pedal Pulse for 95 Knots Level Flight for UH-1B Helicopter and Simulator.

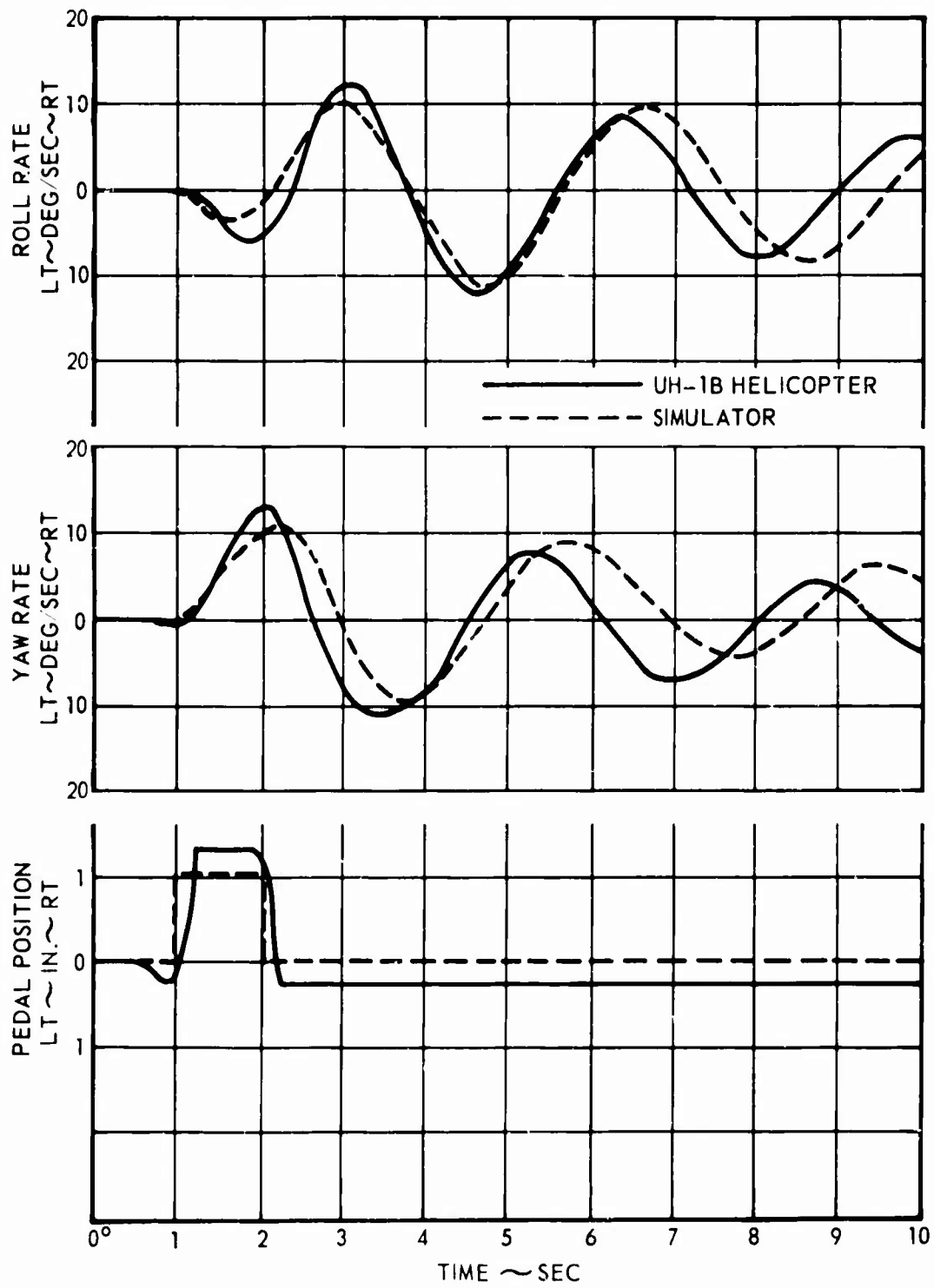

Figure 8. Reaction to a Right Pedal Pulse for 54 Knots Climb for UH-1B Helicopter and Simulator.

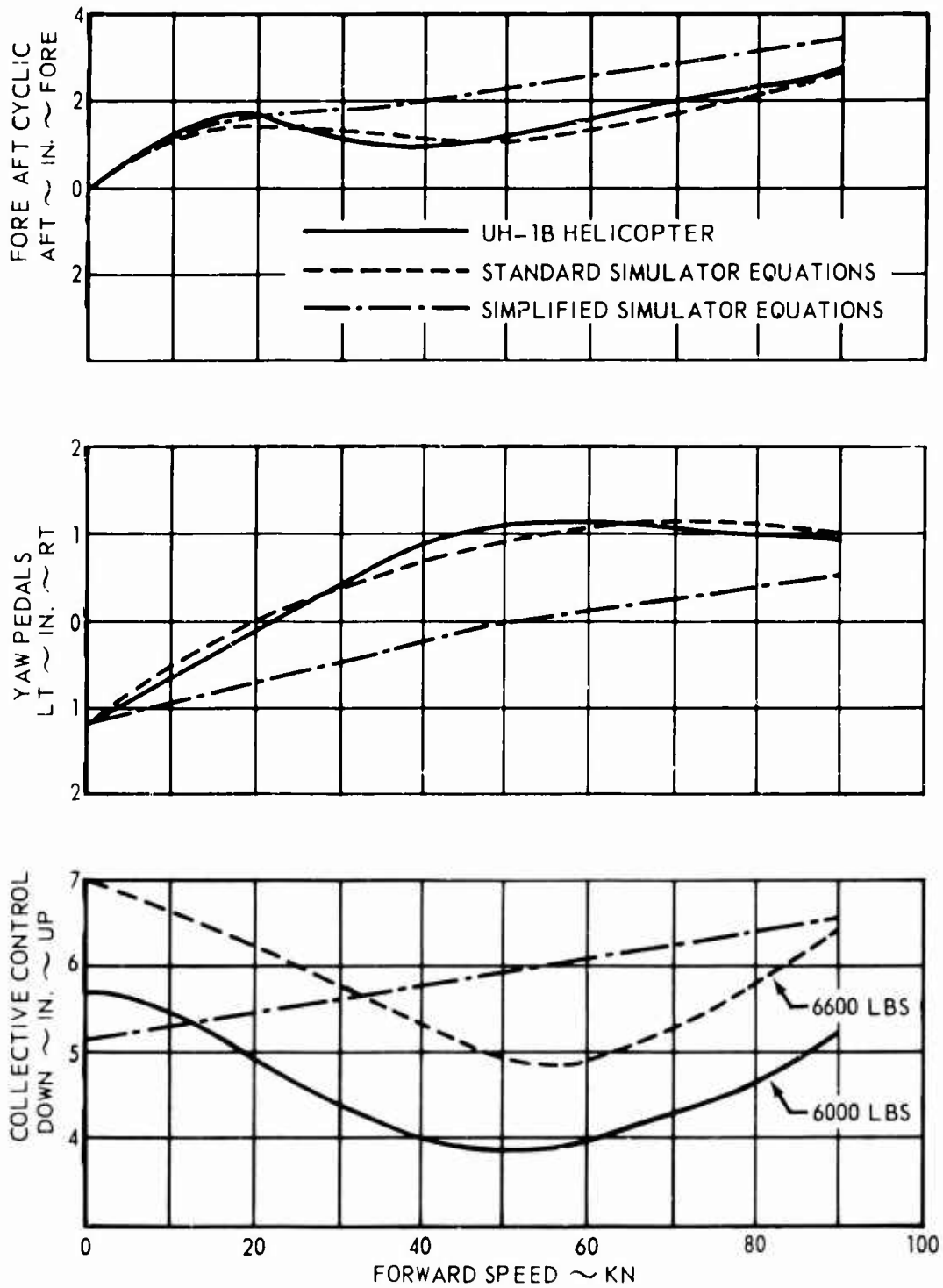

Figure 9. Control Positions Versus Speed in Level Flight (Out of Ground Effect) for UH-1B Helicopter and Simulator.

3. PILOTS

All pilots were employees of Bell Helicopter Company. Three were members of the Experimental Flight Test Staff. Each had logged several hundred hours of previous UH-1B helicopter flight. Four other pilots were helicopter-rated with extensive experience in a variety of previous simulator evaluations programmed with UH-1B equations. The extent of flight time logged for the seven pilots ranged from 1050 to 3700 hours.

SECTION III. DESCRIPTION OF DATA

A. OPERATING CONDITIONS

All data were obtained from time-history records of simulator and flight tests. The records were grouped for pilots and maneuvers.

1. AIRCRAFT SIMULATOR CORRELATION STUDY

Table III lists the conditions for which the records of three pilots' flights were grouped.

TABLE III. FLIGHT AND SIMULATOR MANEUVERS FOR THREE PILOTS			
Maneuvers*	UH-1B	Simulator	
		Full Motion	No Motion
(1) Acceleration to 40 KN and Return to Hover	X	X	X
(2) Maximum Power Takeoff and Transition to Cruise	X	X	X
(3) 1000-Ft/Min Rate of Climb With Constant 70-KN Airspeed	X	X	X
(4) 1000-Ft/Min Rate of Descent With Constant 70-KN Airspeed	X	X	X
(5) Six-Degree Glideslope Landing Approach From 500-Ft Alt	X	X	X
*Oscillograph records were continuous throughout the maneuvers.			

2. SIMULATOR PLATFORM AND EQUATIONS OF MOTION STUDY

Table IV lists the conditions for which four additional pilots' records were grouped. All records were made from 2-minute hover flights.

TABLE IV. CONDITIONS OF HOVER FLIGHT FOR FOUR PILOTS		
Type of Platform Motion	Simulator Equations	
	Original UH-1B	Simplified UH-1B
(1) Pitch, Roll, Yaw, and Heave (With C.G. Offset)	X	X
(2) Pitch, Roll, Yaw, and Heave (With no C.G. Offset)	X	X
(3) Pitch, Roll, Yaw (With C.G. Offset)	X	X
(4) No Platform Motion	X	X

B. DATA ACQUISITION

1. ITEMS MEASURED

The following six channels of data were available for all flight and simulator tests:

- Fore/aft cyclic control position
- Lateral cyclic control position
- Directional control position
- Aircraft pitch attitude
- Aircraft roll attitude
- Aircraft heading

2. FLIGHT RECORDS

The records of control positions were taken from voltage variations out of potentiometers mounted in the control linkages. Aircraft pitch and roll attitudes were taken from the attitude gyro. Heading was recorded from a J-2 electric compass. The paperspeed of the onboard oscillograph was set at 250 mm/sec. A lower speed would have been sufficient, but the oscillograph used was unreliable below this rate.

3. SIMULATOR RECORDS

Simulator data were taken from a Sanborn recorder that was run with paper speed of 10 mm/sec. At this rate, data could be read at a sufficient number of points to numerically sample the rise times in the traces of the various channels. All voltage variations were available as outputs of analog computer amplifiers.

C. DATA REDUCTION

All time-history traces were converted into numerical form and scaled. Aircraft and simulator attitude variations were sampled at .5 sec intervals. Control deflections were sampled at .2 sec intervals because of their more rapid variations. For convenience in the further treatment of the data the sampling interval of the attitude variations was also reduced to .2 sec by polynomial interpolation of fourth order. This left sample values at full seconds unchanged and created 4 interpolated points for the fractions of each second, discarding the points at each full and a half second (see example in Figure 10).

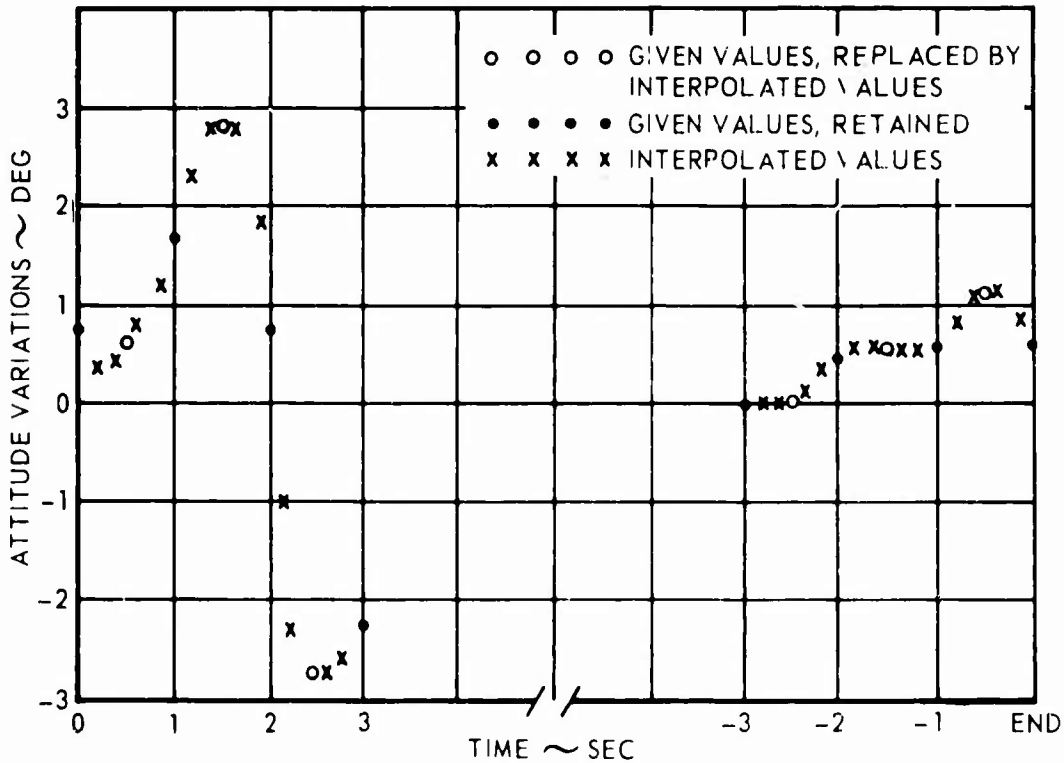

Figure 10. Example of Interpolation Procedure.

The interpolation procedure was checked against the actual traces and was found to be accurate for the low-frequency attitude traces. All data were stored on magnetic tape. The coding of the different test conditions, the scale factors, the number of sample points obtained for each parameter measured, and the interpolation subroutine are shown in Appendix I.

SECTION IV. METHOD OF ANALYSIS

A. COEFFICIENT OF CORRELATION

1. ASSUMPTIONS IN THE ANALYSIS

The analysis described was based on the following assumptions:

- (1) There exists some significant mathematical correlation between what an individual does (performance) in one system and what he does in a second system for a particular maneuver. In other words, so long as there is some relationship between the systems, a higher correlation will be obtained from data of a single individual and of a particular maneuver than from data of random individuals and maneuvers.
 - (a) The correlation will increase with an increase in the similarity of the systems.
 - (b) The correlation will increase with an increase in the appropriateness or relevance of the index of performance used.

To illustrate the implications of these assumptions, consider the following example. A pilot is required to fly three systems. One system (A) is the aircraft; the second (B) is a highly sophisticated simulator that everyone agrees, on the basis of subjective handling qualities, is very much like the aircraft. The third (C) is a low-quality simulator that everyone agrees is unlike the aircraft. With this example, it is rational to assume that on some objective similarity scale, system A is closer to system B than it is to system C.

Now let us also assume that two different types of measurements (a and b) were taken of the pilot's performance in each of the three systems. This would produce the following sets of data:

$$\begin{array}{ccc} \frac{A-a}{A-b} & \frac{B-a}{B-b} & \frac{C-a}{C-b} \end{array}$$

We would expect the correlation of A-a with B-a to be higher than the correlation of A-a with C-a. We would also expect the correlation of C-a with B-a to be higher than the correlation between C-a and A-a. We would expect the same relationship for the b type of measurements.

If for either measurement these relations did not hold, we would be entitled to the suspicion that the measurement is somehow invalid.

Moreover, if the correlation between A-a and B-a is higher than between A-b and B-b, this constitutes a degree of evidence that measurement a is more valid than measurement b. It can also be said that if the situations have higher self-correlations using one measurement instead of the other, then the one is more reliable than the other.

- (2) There will be a correlation of performance for types of maneuvers performed on different systems and by different individuals.
 - (a) As (1a) above.
 - (b) As (1b) above.
- (3) There will be a correlation of performance with any subsystem as it is moved between systems.
 - (a) As (1a) above.
 - (b) As (1b) above.

It should be restated that these are assumptions and not hypotheses; thus, the results are meaningful only if the assumptions are accepted, although they are unproven. A theoretical proof of the assumptions was precluded by the nature of the data.

B. CORRELATION FUNCTIONS

1. THEORY

A derivation of the theory of correlation functions is not attempted at this point, but merely a short review for the reader who is basically familiar with this theory. A more interested person may refer to the references (4, 5, 6, and 7).

The application of autocorrelation and cross correlation functions for the task of interpreting time history data is based primarily upon the assumption that the process which yields the data is a stationary random one. The statistical properties of the system in which the process occurs must be independent of time. A second assumption is that any large number of observations made on the output of a given system has, for arbitrarily selected instants in time, the same statistical properties as a large number of observations made on the outputs of arbitrarily selected, similar systems at the same instant in time.

In theory, one would expect these assumptions to be most closely approximated under those conditions in which the output

characteristics of the system remain unchanged over a period of time during which the system is sampled.

Systems that include human operators obviously will not fulfill the above assumptions in a strict sense, even if such factors as learning and fatigue are eliminated. Unlike other systems, humans change their response patterns from time to time without any observable change in the exterior environment. Very long records will thus not necessarily yield results of greater statistical confidence. Visual inspection of the oscillograph records permitted the elimination of records in which sudden changes in behavior were obvious.

2. AUTOCORRELATION FUNCTION (ACF)

a. Definition and Interpretation

The ACF is mathematically defined by

$$ACF(r) = \lim_{T \rightarrow \infty} \frac{1}{2T} \int_{-T}^{+T} f(t) \cdot f(t-r) dt \quad (1)$$

The ACF for a random time function $f(t)$ that does not contain period components is a monotonically decreasing function. The value of the ACF is equal to $f^2(t)$ at $r = 0$ and equal to $\overline{f(t)^2}$ at $r \rightarrow \infty$. The ACF expresses the statistical dependence of a functional value at some time $t = (t_1 + r)$ from a functional value at $t = t_1$. If the time function $f(t)$ contains a periodic component, the ACF will contain the same periodic component for large values of r .

b. Practical Computation of the ACF

In actual practice, the ACF must be computed from a time function record of limited length. Digital computation also requires the integration to be replaced by a summation; that is

$$ACF(r_j) = \frac{1}{N-j} \sum_{i=1}^{N-j} f(t_i) \cdot f(t_i - r_j) \quad (2)$$

$ACF(r_j)$ is normalized by subtracting out its average value and dividing through by its zero argument. Note, however, that it is numerically advantageous to subtract the average out of the time function before the correlational process. The mathematical equivalence is shown in Appendix II.

The limited record length also allows only a limited time shift τ ; of not more than 10 percent of the total record length. This has been investigated in the subject data points and has been shown theoretically in Reference 8.

3. CROSS CORRELATION FUNCTION (CCF)

a. Definition and Interpretation

The CCF is mathematically defined by

$$CCF(\tau) = \lim_{T \rightarrow \infty} \frac{1}{2T} \int_{-T}^{+T} f_1(t) \cdot f_2(t - \tau) dt \quad (3)$$

The CCF expresses the statistical dependence of a functional value $f_1(t_1)$ at time t_1 from the value of another function $f_2(t_1 - \tau)$ at time $(t_1 - \tau)$.

The $f_1(t)$ represents rates of control deflection, and $f_2(t)$ represents aircraft attitude about one of the three axes. Aircraft attitudes are positive when they are in the clockwise sense for an observer looking into the positive x, y, and z directions of the coordinate system, as shown in Figure 11.

Positive control deflections are left stick, forward stick, and left pedal. These positive control deflections produce negative ship responses in the roll, pitch, and yaw axes, respectively.

A negative value of the cross correlation function (CCF) thus indicates in our case that the mode of control deflection and the ship responses are in the same direction. For example, right stick mode and right roll give negative correlation.

Figures 12 and 13 illustrate the meaning of the CCF in general.

The point E1 where the CCF goes through zero indicates lead or lag between an aircraft attitude error and a corrective stick motion. If E1 is located to the left of the ordinate there is lag, and if E1 is to the right of the ordinate there is lead. Lead means that the pilot reverses the direction of motion of the control before the ship has reached the reference attitude during an oscillation.

The value of the CCF at $\tau = 0$ is a measure for the quality of control. Large negative values of CCF0 indicate that the pilot is disturbing the system; i.e., the rate of control deflection is in the direction that tends to increase the disturbance.

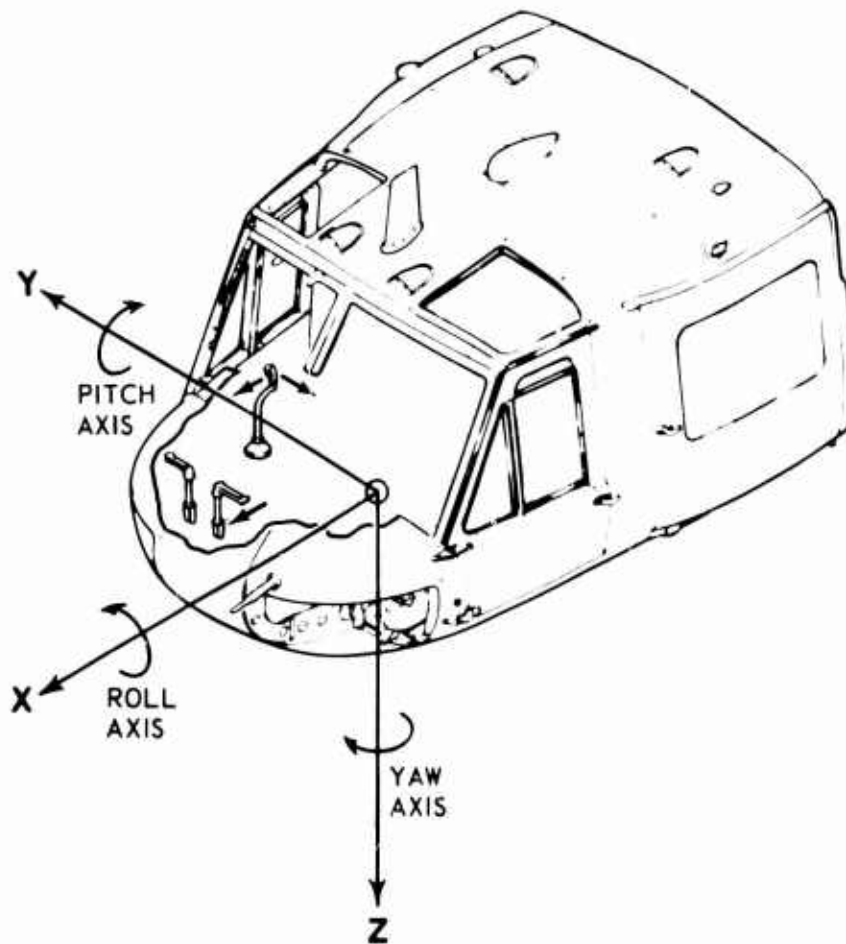

Figure 11. Coordinate System of the Aircraft and Direction of Positive Control.

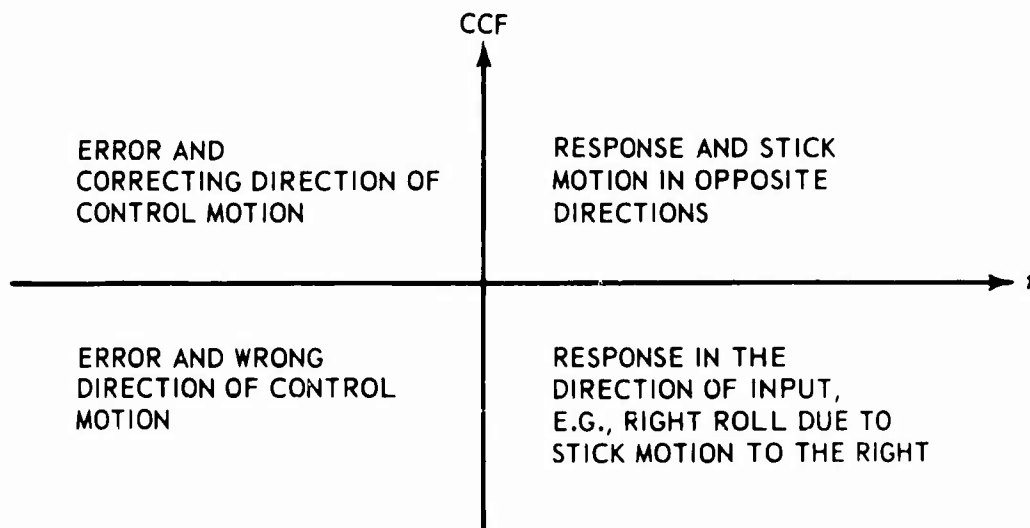

Figure 12. The Meaning of the Four Quadrants for a CCF.

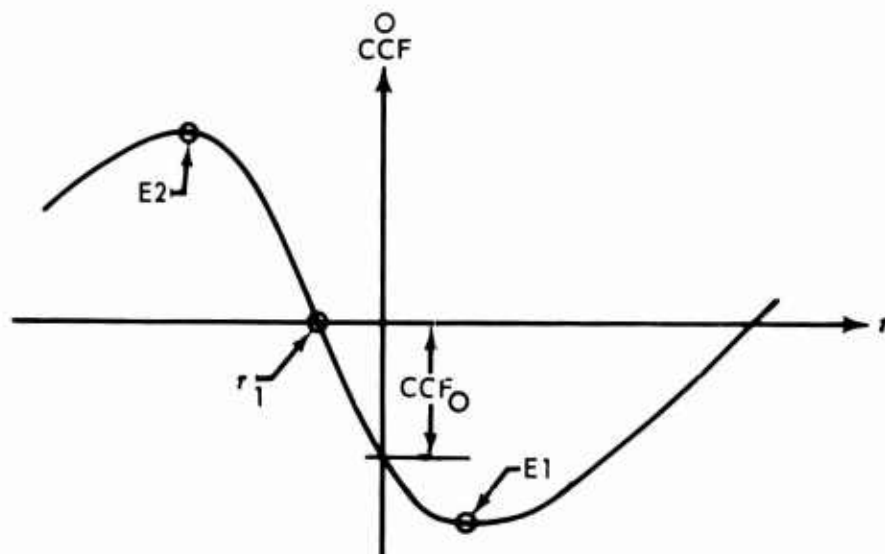

Figure 13. Typical Example of a CCF.

The point E1 shows how long it takes on the average until the ship has reached, for example, the maximum right roll attitude after a right-hand rate was imposed on the lateral control. Similarly, E2 shows how long it takes for the pilot, until he has built up the maximum rate of control deflection, to correct a disturbance.

Figure 14 may elucidate these statements further. It shows the two time functions $f_1(t)$ (rate of control deflection) and $f_2(t)$ (ship attitude) shifted relative to each other by $-r$ according to the definition of the CCF in Equation 3. It follows from inspection of Figure 14 that the highest negative correlation with the control pulse can be seen about r sec later in the ship attitude trace. In the correlation process, all such occurrences are averaged.

High absolute values of the CCF at the points E1 and E2 indicate that there is a high correlation between stick rate and aircraft attitude. A high CCF means that attitude is an important cue for the pilot.

The CCF is normalized by dividing the values as obtained by Equation (3) by $\sqrt{f_1^2(t) \cdot f_2^2(t)}$. The average has been subtracted out of the time functions (see Appendix II).

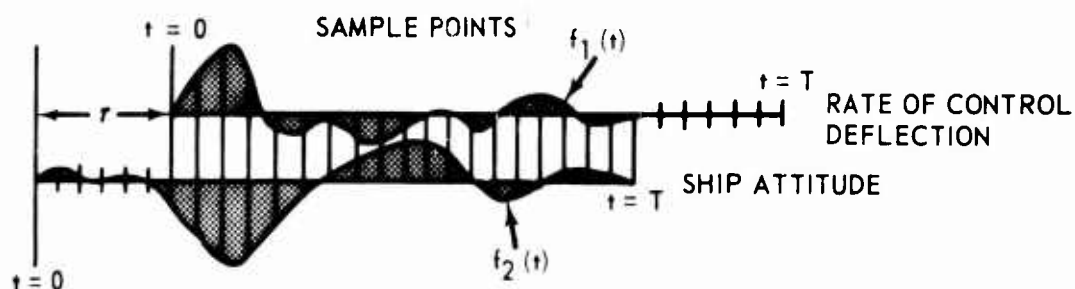

Figure 14. Illustration of Negative Time Shift $-r$ Between $f_1(t)$ and $f_2(t)$.

After the normalization, the amplitudes of the CCF do not contain information about the magnitudes of $f_1(t)$ and $f_2(t)$. This information is contained in the analysis described in Section IV,B.

b. Practical Computation of the CCF

In the actual computation of the CCF, Equation (3) was replaced by corresponding summations, as in the case of the ACF.

C. ERROR PARAMETERS

1. ATTITUDE ERROR

Typically, the evaluation of performance on tracking tasks has been based upon such measurements as absolute error, root mean square error, time on target, etc. The disadvantages of these techniques are evident. First, the arbitrary assignment of a linear (absolute error), a geometric (root mean square error), or a categorical (time on target) scale to the results do not take into account the momentary dynamics of the flight situation. Second, they are based upon what the tester has decided to call correct, which may differ from what the operator perceives to be correct.

There is, perhaps, an even more fundamental problem involved. None of the scales consider the operator's attitude toward his

task. If error, as measured in these scales, is the single crucial factor, it is likely that a nervous, hypersensitive, overactive operator will appear to be the best pilot. The calm, yet competent, individual would not be so hasty to correct error since he realizes that a certain amount of error can be tolerated in the interest of smoothness of operation.

2. CONTROL EFFICIENCY

It seems evident that a better notion of performance than error is some ratio of error to the operator's manual responses which are required to nullify the error. This, after all, describes the efficiency of the total system. If error exists but the pilot does nothing to correct the error, one cannot say that he has performed efficiently. On the other hand, the actual error may be small, but if this is obtained only by a constant recorection of the controls, one cannot say that this is an efficient system.

Thus, both the input (amount of work done by the operator) and the output (amount of error) seem important to a description of true performance. Efficiency then would be the ratio of performance (reciprocal of error) to the work accomplished in the production of that performance. Inefficiency would, of course, be the product of error and work.

Previous work with efficiency measurements have been somewhat successful. In one study (Reference 9) the frequency of accelerative inputs exceeding a specified value were multiplied with accumulated error. This single technique was found to control variance better when compared to error alone. In a second study (Reference 10), comparison was made between simulator modes using the product of accumulated error and accumulated control stick accelerations. Again the results were somewhat more systematic than those based upon error alone.

In a physical system, the idea of work relates to the product of force and distance. However, this is not an especially good description of what is meant by work in the present context. Although the physical output required to move the control levers could become a significant factor if it were of a magnitude to induce fatigue, this is not likely to be the case in normal simulator or aircraft operation. It is true that operators become fatigued from operating the systems, but this is not due, except in very small part, to the physical labor involved. It is assumed, therefore, that the actual physical work (overcoming the frictions, breakout forces, inertias, etc.) is an insignificant element within the present consideration.

There exists something, however, that can be called "mental work" which does enter consequentially into the task. Mental

work involved in flying an aircraft has to do with the difficulty and the rapidity with which control judgments are made. From an inspection of his instrument or visual references, the operator perceives a discrepancy between the existing and the desired condition of his system. Depending on the magnitude and presumed importance of the discrepancy, he makes a judgment as to the action required to bring the discrepancies into a satisfactory alignment. Since flying an aircraft requires a continuous series of such judgments, mental work seems closely associated with the number of judgments made per unit time.

We have, of course, no direct manner in which to measure the frequency of these judgments. However, we can obtain some index of this rate from the operator's control movements. Most judgments produce a change (however slight) in control. The measurable parameter that seems most intimately associated with judgmental changes is the rate of change of acceleration of the control lever. Since a unitary decision would seem to have its physical manifestation in a unitary force, the changes in force, which produce changes in acceleration, should correlate with the amount of mental work accomplished. Be this as it may, it was not possible to make this analysis with the data available since the only index acquired was control position, and it was recognized as not feasible to make more than one differentiation on this parameter. The present analysis consequently used rate as an index of work. This was not ideal, but it is related to oscillations of the controls since control movements are very limited and sustained rates cannot be maintained for any period of time. This preempted any sustained accumulation of rate bringing this parameter into close relationship with the rate of change of acceleration.

3. MEASURES OF PERFORMANCE GENERATED TO EVALUATE CONTROL EFFICIENCY

Three measurements of performance were generated:

- Sum of absolute error $\sum |e|$
- Sum of absolute error multiplied by the control rates $\sum(|e|w)$
- Sum of absolute error multiplied by the sum of the rates $(\sum |e|)(\sum w)$

It will be recognized that the last two measurements are indices of inefficiency.

The values used are shown as Appendix III. Since the values for $\sum |e|$ and $\sum(|e|w)$ were highly skewed, as can be seen, they were normalized through a log conversion before correlations were performed.

SECTION V. RESULTS

A. CROSS CORRELATION ANALYSIS

1. FORWARD FLIGHT

a. Acceleration and Deceleration Maneuver

This short-term transition maneuver is basically not very well suited for analysis by correlation functions. The following statements therefore have to be considered only as an attempt at interpretation.

During an acceleration, power increases. This induces yaw responses which must be corrected by a tail rotor thrust increase. For trim, a left roll attitude is required; i.e., the stick has to move over to the left. The CCF for the roll showed that the pilots did not correct for long-term roll attitude deviations, since the CCF for negative values of τ is shifted down into the third quadrant. The oscillations in roll occurred about the short-term shifting average value. Therefore, the pilot's lag time for roll control was taken at the location of the first relative maximum in the negative regime. This is shown in Figure 15.

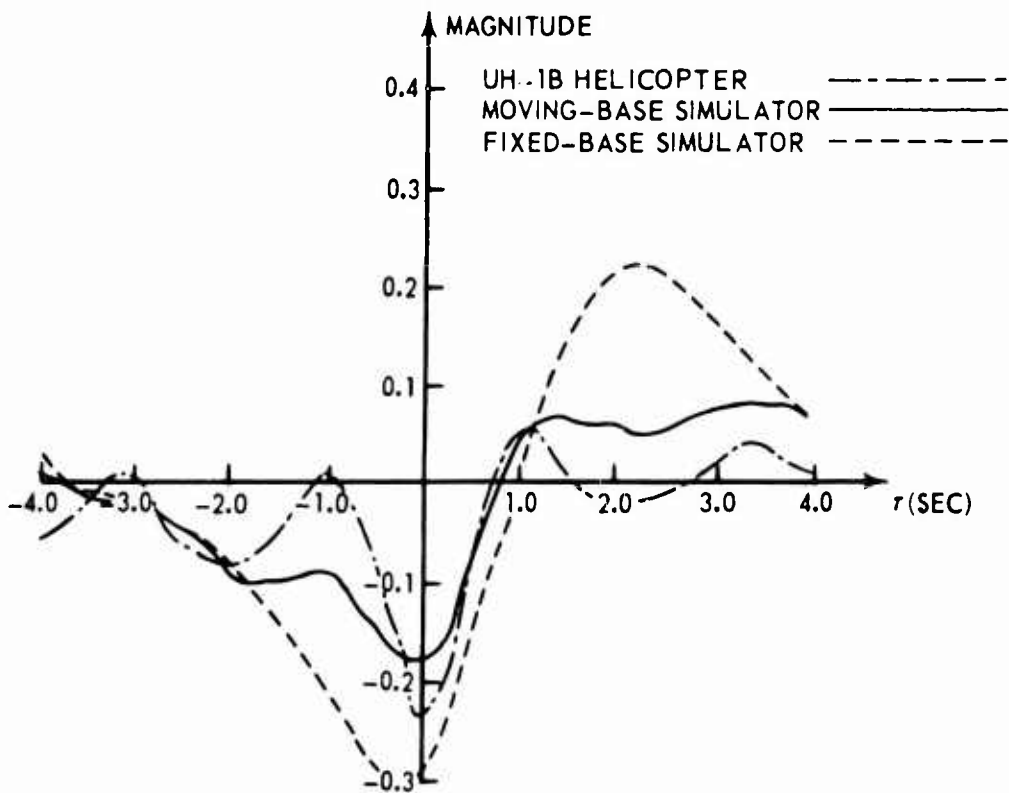

Figure 15. CCF of the Roll Channel for the Acceleration Maneuver.

The roll control lag in the moving-base simulator and that in the aircraft were, on the average, about the same. Due to the nature of the maneuver, roll attitude changes were fairly large and thus could be detected easily in both the moving-base simulator and the aircraft. The fixed-based simulator trace indicates much higher pilot's control lag.

The CCFs for the pitch channel, Figure 16, are biased for reasons similar to those for the roll channel. The steady trace for the aircraft contrasts the oscillating simulator trace. This is mainly caused by the normalization process described in Section IV. The mean square value used in the normalization of the aircraft pitch attitude trace is much higher than the one for the simulator (see Figure 17). This is caused by the larger long-term pitch attitude excursions of the aircraft. The CCF is limited to $\tau = \pm 4$ sec and hence shows only the short-period oscillations, which with respect to the mean square values are much larger in the simulator.

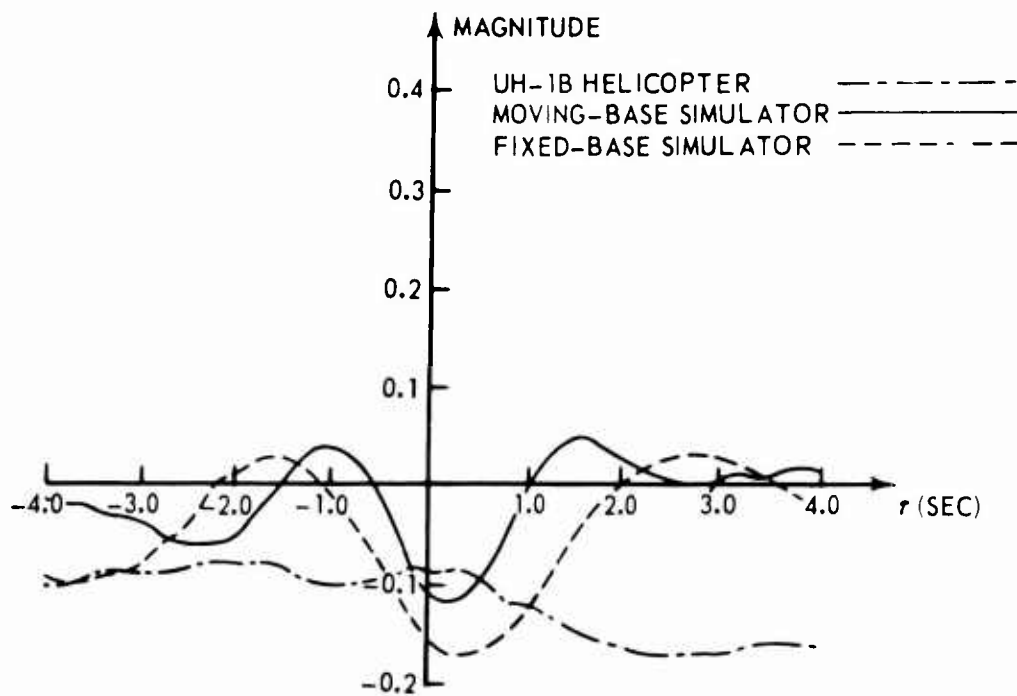

Figure 16. CCF of the Pitch Channel for the Acceleration Maneuver.

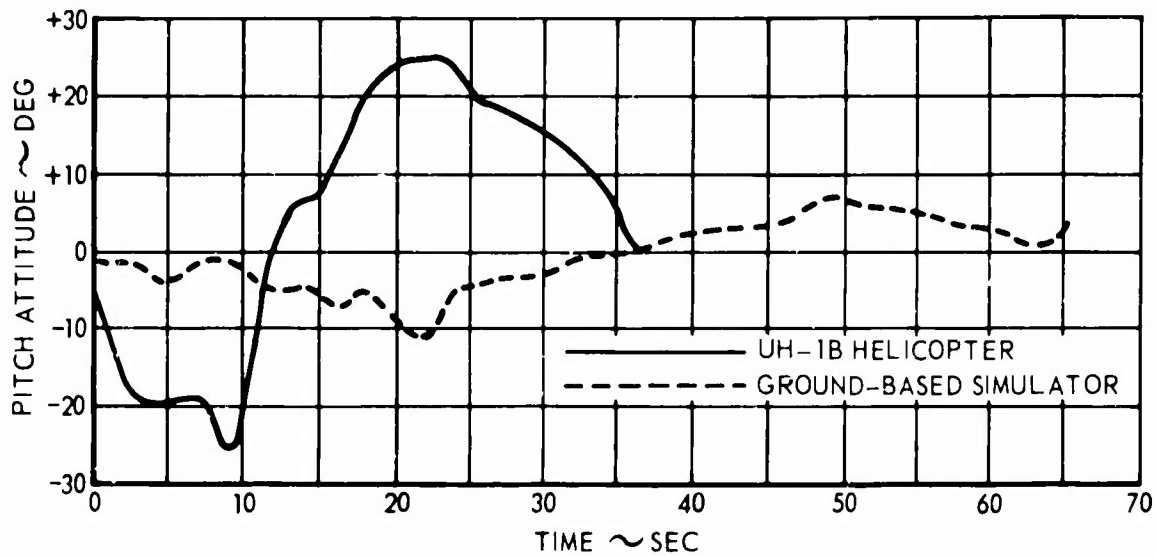

Figure 17. Pitch Oscillations During the Acceleration in Aircraft and Simulator.

The nature of the yaw response is very similar to that of the roll response and does not yield any new information.

b. Maximum Power Takeoff Maneuver

The pitch channel characteristics agree in general with those found in the preceding maneuver. The main difference is that even in the aircraft, small, short-term oscillations occur superimposed upon the large, nose-down attitude. This is shown by the more pronounced periodic oscillation of the aircraft CCF (see Figure 18).

The pitch oscillations during the maximum power takeoff in the aircraft and simulator are shown in Figure 19.

The roll channel shows very similar shapes of the CCFs for the simulator and the aircraft. The simulator curve is shifted slightly downward relative to the aircraft curve. For reasons explained in the previous maneuver, this is believed to be insignificant. As in the previous maneuver, when there was no platform motion the CCF changed significantly (see Figure 20), indicating larger control lag of the pilot.

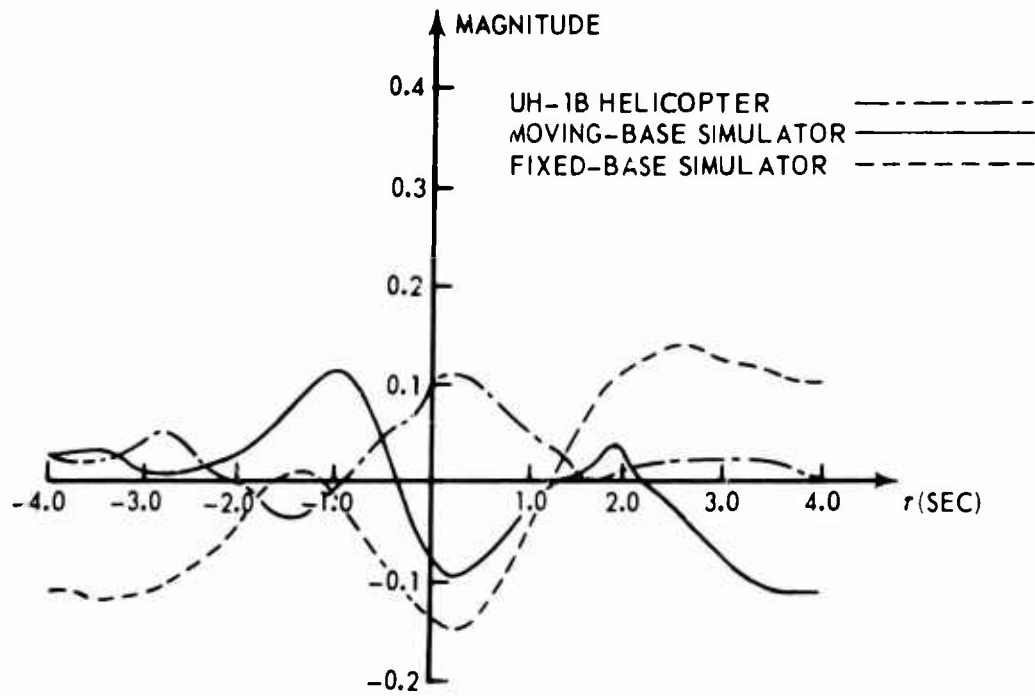

Figure 18. CCF of the Pitch Channel for the Maximum Power Takeoff.

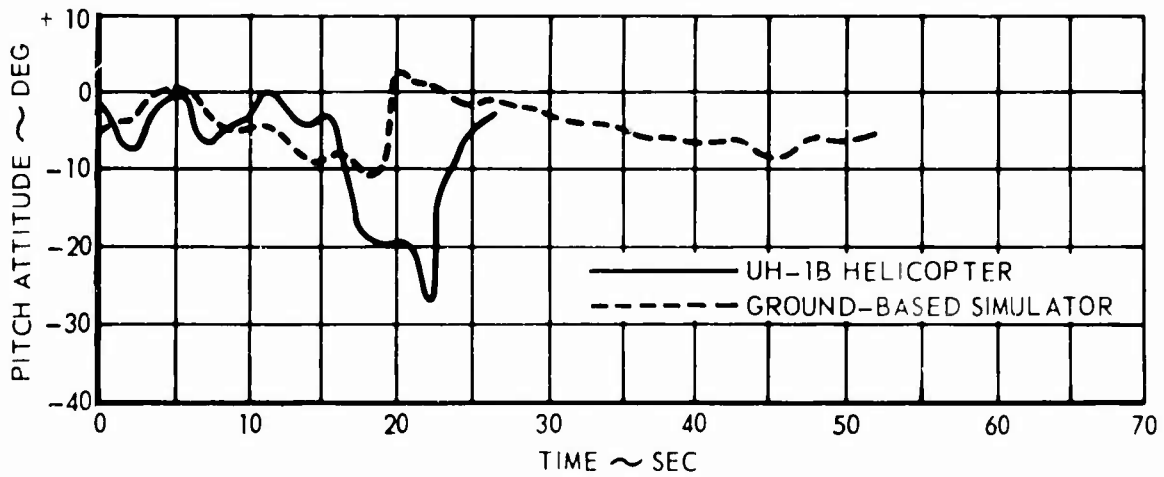

Figure 19. Pitch Oscillations During the Maximum Power Takeoff in Aircraft and Simulator.

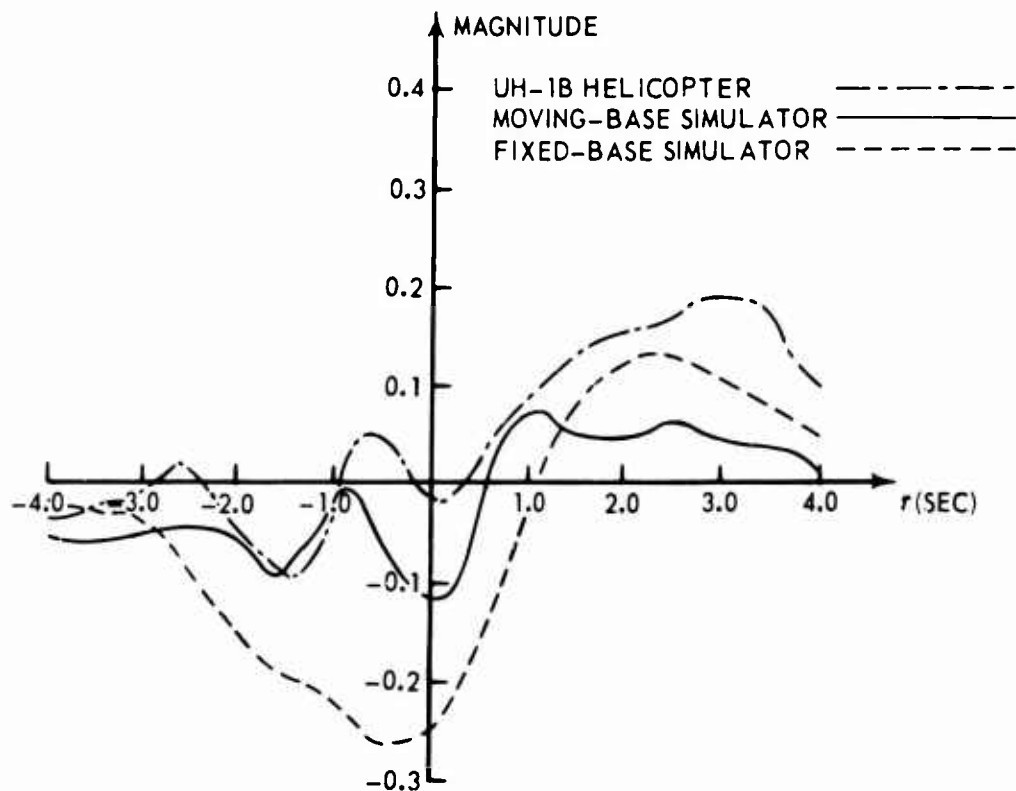

Figure 20. CCF of the Roll Channel for the Maximum Power Takeoff.

The yaw channel could not be interpreted in this manner because of the strong dependence of pedal position upon power changes.

c. Climb at 70 Knots

In climbs the rotor damping is deteriorated because of higher inflow. This affects mainly the roll axis and to some extent the pitch axis. This can be seen in the pitch CCF of the aircraft shown in Figure 21. The longer frequency component for the simulator CCF indicates more pitch stability than in the aircraft.

The roll channel is less precisely controlled in the simulator than in the aircraft. It is indicated that this again is mainly a pilot-induced oscillation (PIO), since one of the pilots made very little stick motion and achieved a very stable roll attitude in the simulator and the aircraft. In general, the pilots reacted in the simulator with larger excursions, which is again indicated by the simulator CCF (see Figure 22).

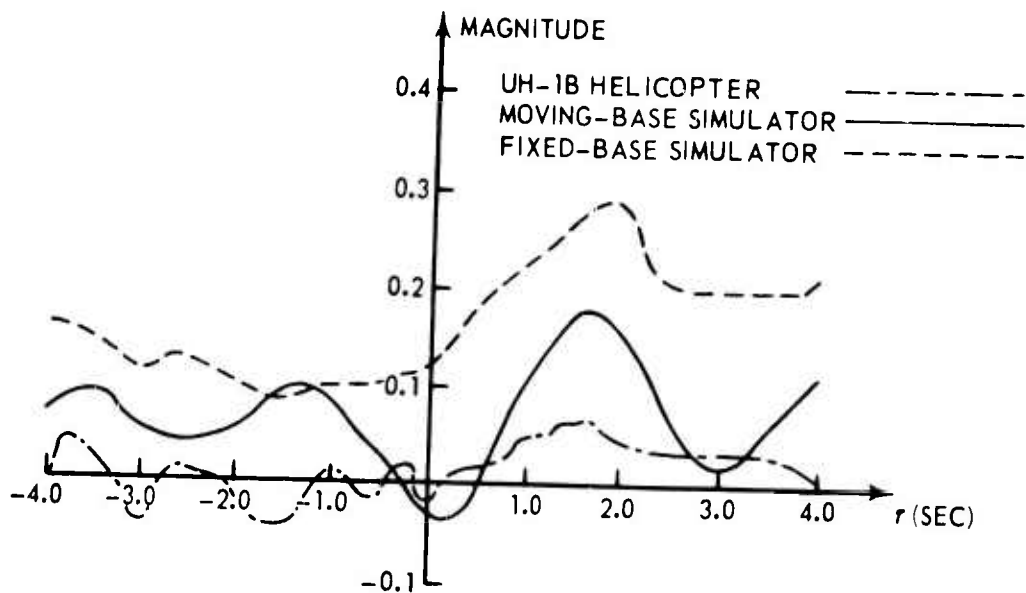

Figure 21. CCF of the Pitch Channel for the Steady Climb at 70 Knots.

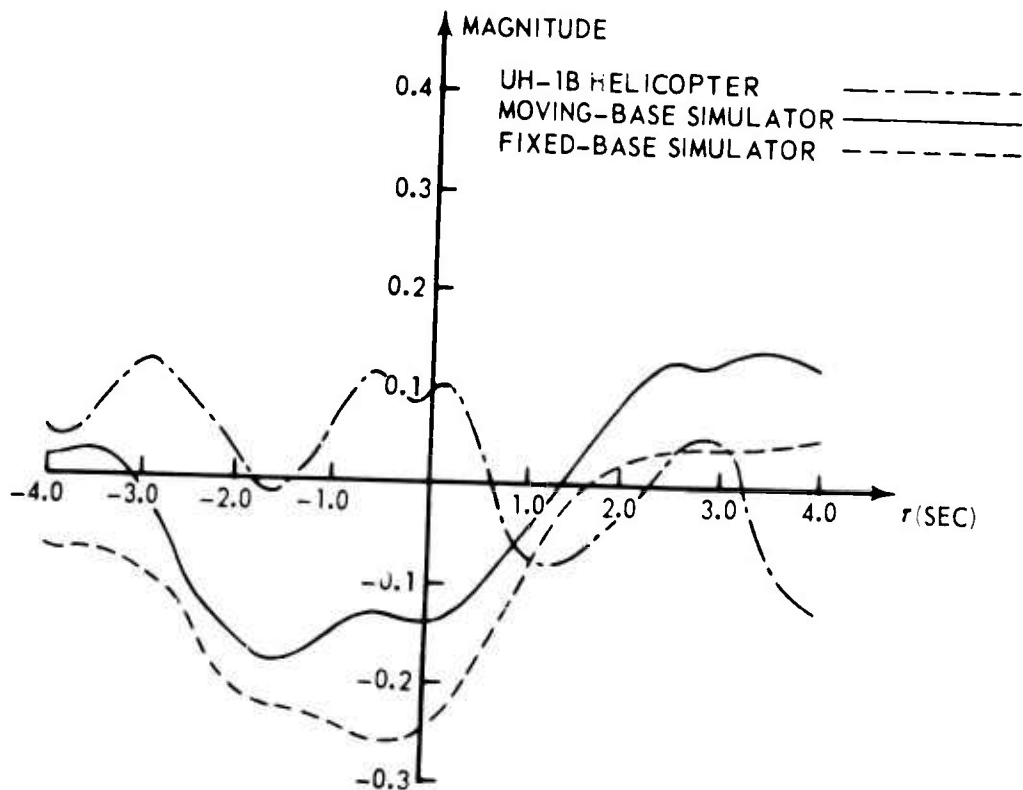

Figure 22. CCF of the Roll Channel for the Steady Climb at 70 Knots.

In both the simulator and the aircraft, the pedals were virtually unused during the maneuver.

d. Descent at 70 Knots

The reversed rotor inflow conditions in a descent together with a low rotor solidity cause a very stable flight condition. The resulting low control activity in most cases did not exceed the resolution capability of the instrumentation. Therefore, a CCF could be obtained only for the roll channel. The apparent difference between the simulator and the aircraft traces shows that the simulator had a small roll oscillation that was not present in the aircraft. The CCF shows this by the different frequency characteristics (see Figure 23). This oscillation must be a PIO, since the dynamic response of the simulator due to a lateral stick pulse was well damped during a descent (see also the next paragraph). The large delay time (of 3 seconds) shown by the CCF confirms this hypothesis. The roll attitude excursions, however, were very small.

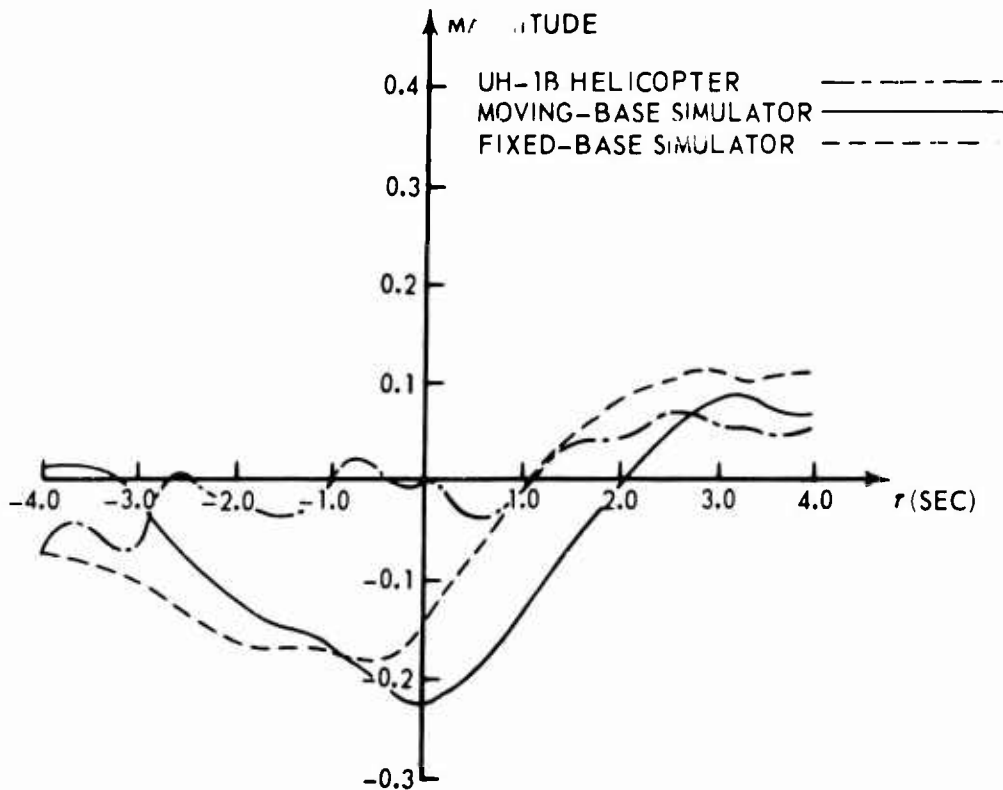

Figure 23. CCF of the Roll Channel for the Steady Descent at 70 Knots.

e. Landing Approach

In the roll channel there is a consistent difference in the CCF of the aircraft and the simulator. This results from a difference in controlling technique. In the aircraft, the pilots correct quickly for small external disturbances with small stick deflections. In the simulator, the actual roll deviations are comparable in magnitude with those occurring in the aircraft. They are, however, caused by the pilot himself when he is not centering the stick precisely after the aircraft has been stabilized. There then occurs a period of no stick activity until the resulting deviation has grown enough to be detectable by the pilot. He corrects with higher stick rates than in the aircraft but obviously has a large time delay, as follows from the previous statements. This fact is clearly reflected in the simulator CCF (see Figure 24).

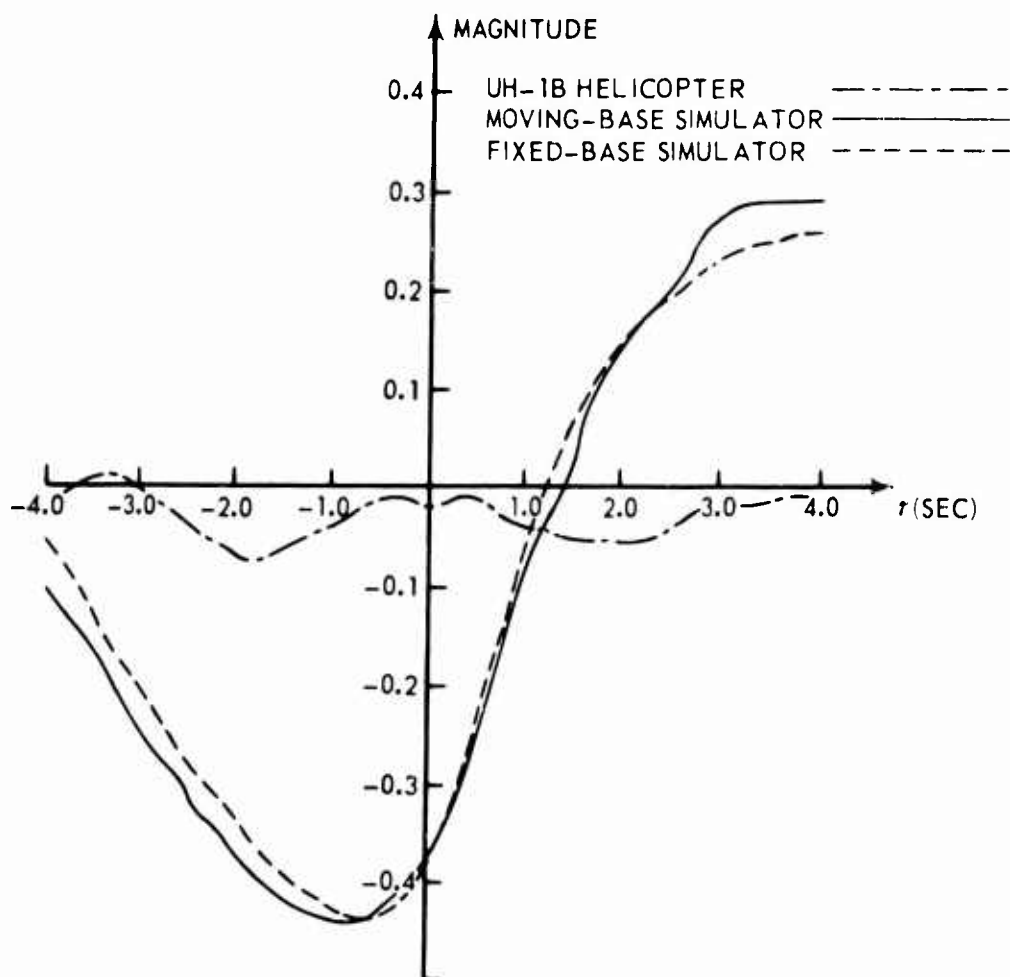

Figure 24. CCF of the Roll Channel for the Landing Approach.

The pitch channel was very stable in the simulator and showed practically no stick activity. This was due to the speed stability. A small deviation from the theoretically correct stick position results in a small attitude deviation that does not build up (roll deviations tend to be built up due to the spiral instability of the aircraft). Thus, no CCF was computed. In the aircraft there was some stick activity since the pilot had to correct for external disturbances.

In the yaw channel only a negligible amount of pedal activity took place in the simulator. The yaw attitude changed not more than ± 1 degree. This indicates that the coupling from roll into yaw was not sufficient for this condition in the simulator. No simulator CCF is shown. The CCF of the aircraft is shown in Figure 25.

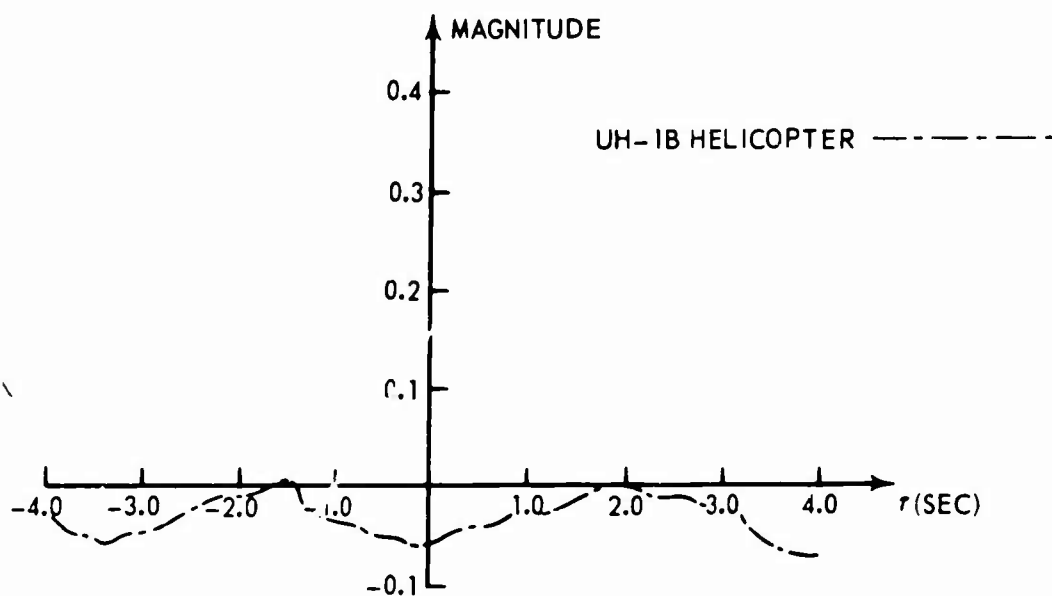

Figure 25. CCF of the Yaw Channel for the Landing Approach.

2. THE EFFECTS OF MOTION IN FORWARD FLIGHT

a. Roll Channel

When going from hover to forward flight, the motion signals fed to the platform were changed. From 0 to 25 knots, there was a one-to-one relationship between the computed aircraft roll angle and the platform roll angle. In the speed range from 25 to 45 knots, a transition was made to a washout circuit; i.e., roll rate was utilized instead of roll attitude. The platform displacements were washed out with a time constant of 9 seconds. This was done to avoid a lateral gravity force component in steady-state turns.

The results show a basic difference between steady-state and transitioning maneuvers in the forward flight regime. In two of the three steady-state maneuvers (cruise descent and landing approach), the roll rates were too small to cause noticeable platform motion. In the climb, the least stable flight condition of the three, some platform roll developed. This changed the CCF of this case slightly (see Figure 22). In the two transition maneuvers, the influence of motion becomes more apparent. This is shown mainly by a frequency component in the CCF that is very similar to the one that is contained in the aircraft (see Figures 15 and 20). This means that motion reduces the pilot's delay time in maneuvers that require large roll control corrections.

b. Pitch Channel

Motion in the pitch axis of the simulator platform did not influence the CCFs in either the forward flight steady-state maneuvers or the transitioning maneuvers.

c. Yaw Channel

The results are inconclusive from the CCF comparisons.

d. Conclusion

Motion of the simulator platform has a noticeable effect only under flight conditions that include large attitude changes. The pilot-simulator loop is, under such conditions, dynamically behaving in a manner more closely related to the actual aircraft than it does to the simulator platform without motions.

3. THE EFFECTS OF MOTION IN HOVER

Detailed studies of the extent of platform motion as a facilitating cue for the pilot were conducted in a steady-state hover. Besides the normal aircraft equations, a simplified set of equations was used.

a. Pitch Channel

Motion, in general, reduced the amount of overcontrolling. It was relatively more effective for the simplified equations. The capability of large excursions in the heave channel did not improve the results (See Figures 26a and 26b).

b. Roll Channel

The same conclusions can be drawn for the roll channel shown in Figures 27a and 27b.

c. Yaw Channel

In the yaw channel, motion improves the precision of control for the normal equations. No improvement was seen when the simplified equations were used (see Figures 28a and 28b).

d. Conclusion

Motion reduces the amount of overcontrolling; i.e., attitude is held more precisely. The lag time r_1 , as defined in Section IV,A,3, is practically unchanged. For steady-state hover, the heave channel, when used for vertical aircraft c.g. displacements, did not aid the attitude control.

4. COMPARISON OF STANDARD UH-1B EQUATIONS WITH SIMPLIFIED UH-1B EQUATIONS

a. Pitch Channel

The effect of platform motion was principally the same for both sets of equations, as discussed previously in the hover results. The CCF of the pitch channel shows a deterioration in the control behavior for the no-motion case (see Figure 26). From the ACF in Section V,B, it can be seen that this is caused by a change in control input behavior more than by a difference in pitch attitude excursions. With the motion on cases, no significant difference can be found between the results from the two sets of equations. No unequivocal reason for this can be suggested.

b. Roll Channel

The roll channel CCF for the standard equations in hover contained a frequency component that caused a characteristic peak at $r_1 = -.5$ sec that had been found earlier in the evaluation of aircraft traces for forward flight. For the simplified equations, however, the roll channel CCF lost this peak. The ACF for control inputs and roll attitude (Section V,B) declines less rapidly. These changes reflect the removal of a yaw-roll coupling term.

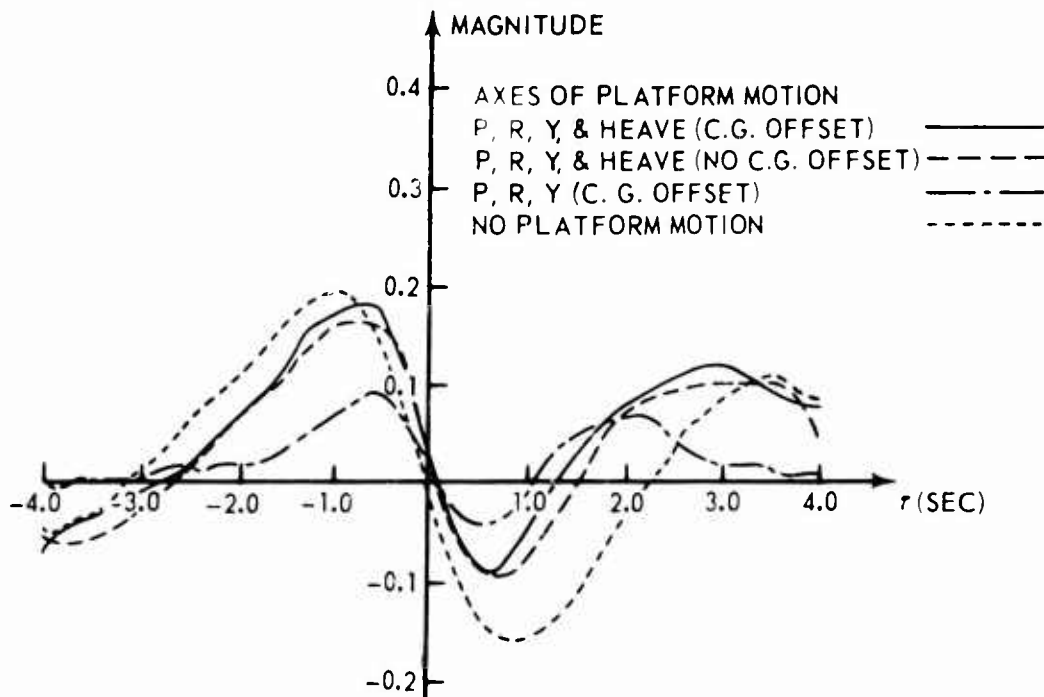

(a) Original Equations

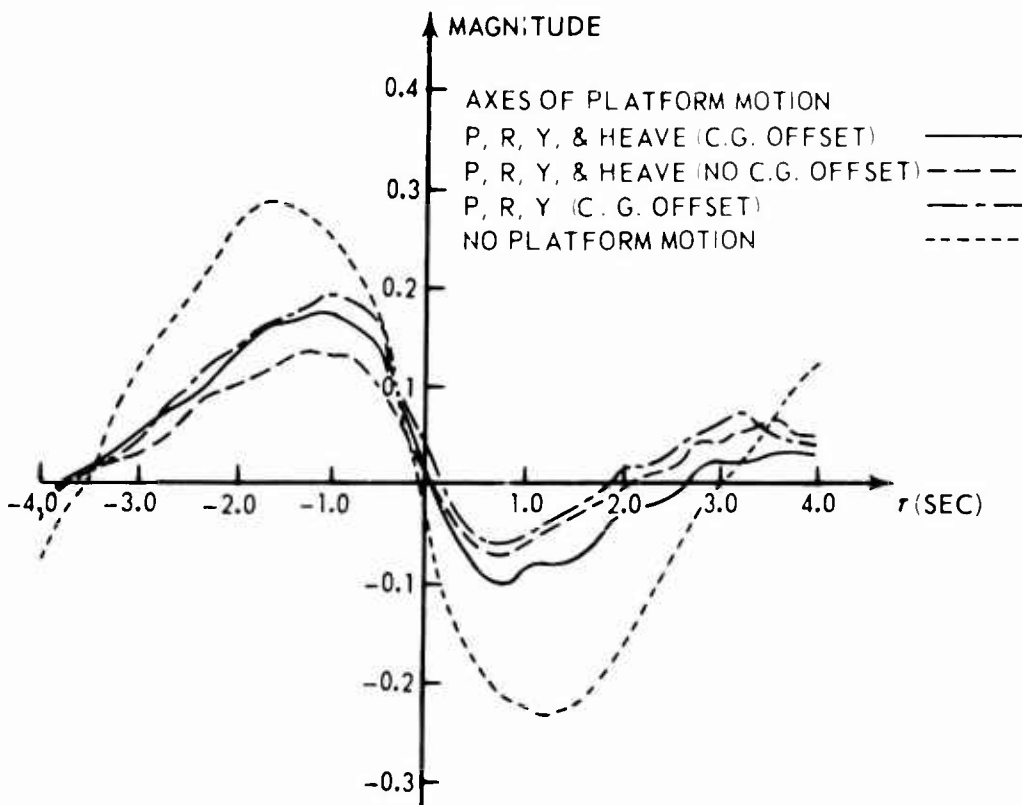

(b) Simplified Equations

Figure 26. CCF of the Pitch Channel for Hover Control.

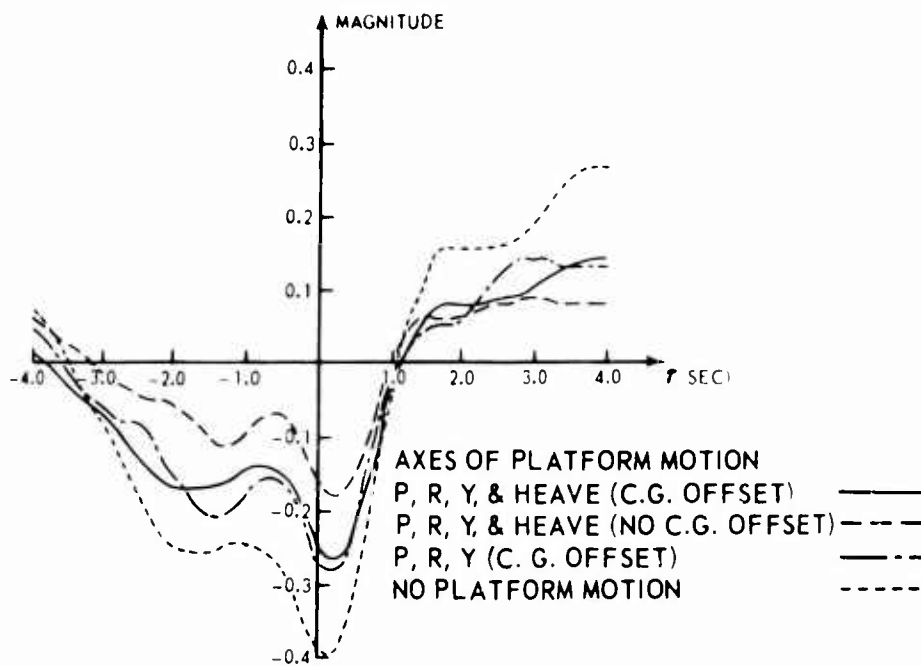

(a) Original Equations

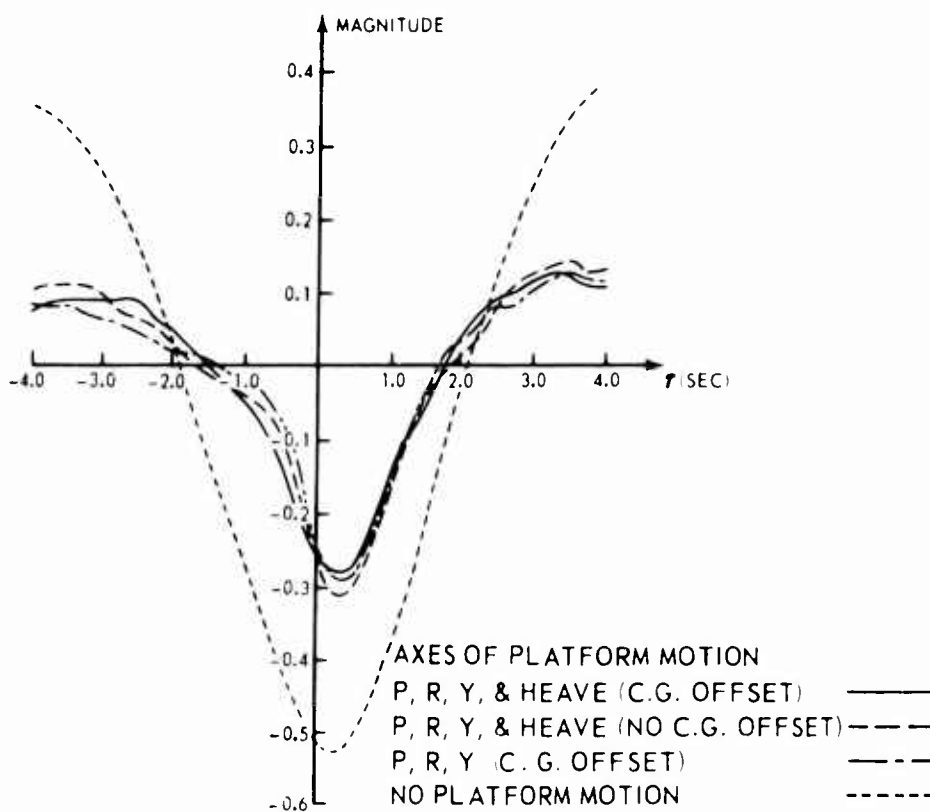

(b) Simplified Equations

Figure 27. CCF of the Roll Channel for Hover Control.

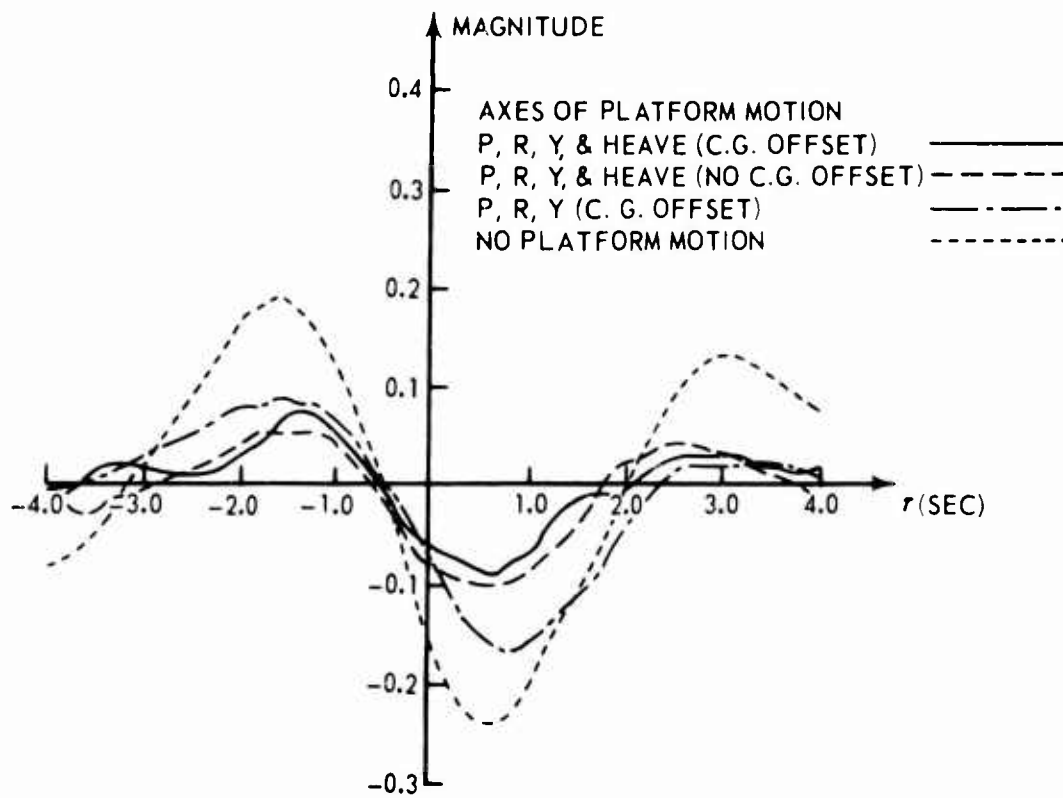

(a) Original Equations

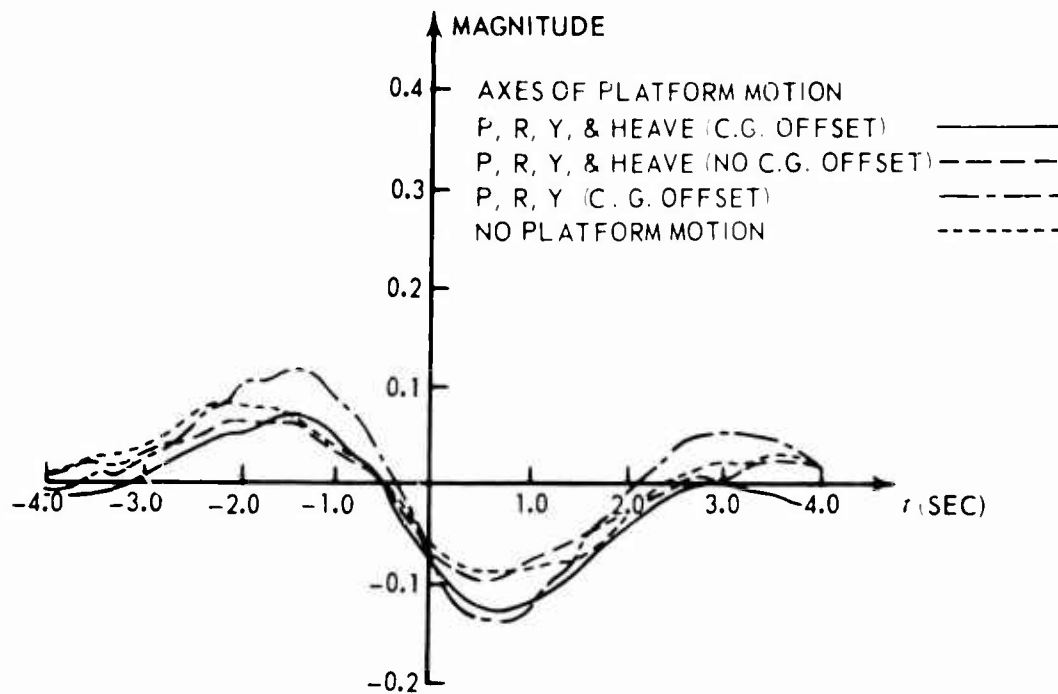

(b) Simplified Equations

Figure 28. CCF of the Yaw Channel for Hover Control.

c. Yaw Channel

The CCF of the yaw channel shows improved quality of control for the simplified equations. The removal of a time delay term for the main rotor and tail rotor thrust in the simplified equations resulted in an effectively higher yaw damping and quicker recognition of the effects of a main rotor collective pitch change. Thus, the control of yaw attitude required less frequent changes in control position.

d. Conclusion

The short investigation in hover with simplified equations shows that the pilot's control behavior changes immediately with only minor changes in the equations. It is expected that the other changes affecting the forward flight regime could be detected equally well. Based on the assumptions of Section IV,A, any simplification of equations that affects the dynamic behavior of a simulator in a flight regime of interest must be rejected when this simulator is used for handling-qualities investigations.

B. AUTOCORRELATION ANALYSIS

1. FORWARD FLIGHT

After the details of the five different maneuvers have been discussed in this section, the results of the ACF will be summarized. The ACF has been evaluated for control positions and aircraft attitudes.

a. Pitch Control

The acceleration and maximum power takeoff maneuvers involved a slow forward motion of the fore/aft stick throughout the maneuver superimposed with small corrective motions. Thus in a normalized ACF, one would expect a fairly gradual decreasing trace, since the stick position at a time $t + \tau$ is very much dependent on the stick position at time t when measured relative to the average change of stick position in those maneuvers. This is seen to be true in the ACFs obtained, and no significant difference between helicopter and simulator traces is apparent (see Figure 29).

The last three maneuvers required corrective pilot action about a fixed point to hold the aircraft flight condition as close to the desired value as possible. The ACFs of the aircraft fall rapidly to low values with increasing τ , whereas the simulator traces decrease much more slowly. This indicates that the pilot in the aircraft continuously moved the stick to make corrections. In the simulator, there was a longer time delay in the stick movements (see Figure 30).

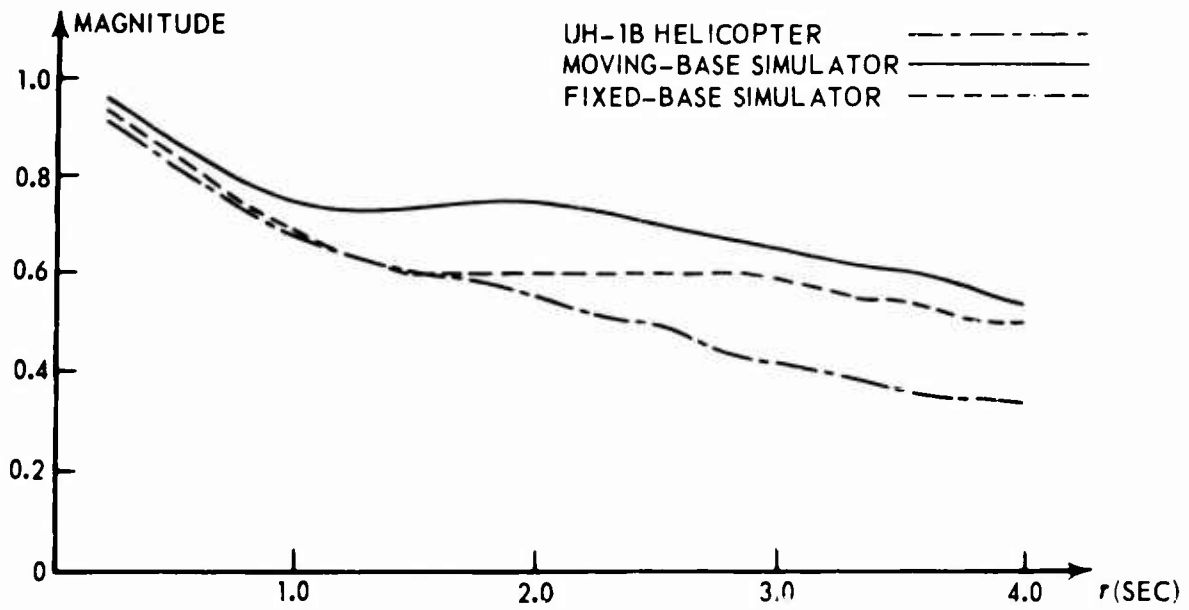

Figure 29. ACF of the Fore/Aft Stick Position For the Maximum Power Takeoff.

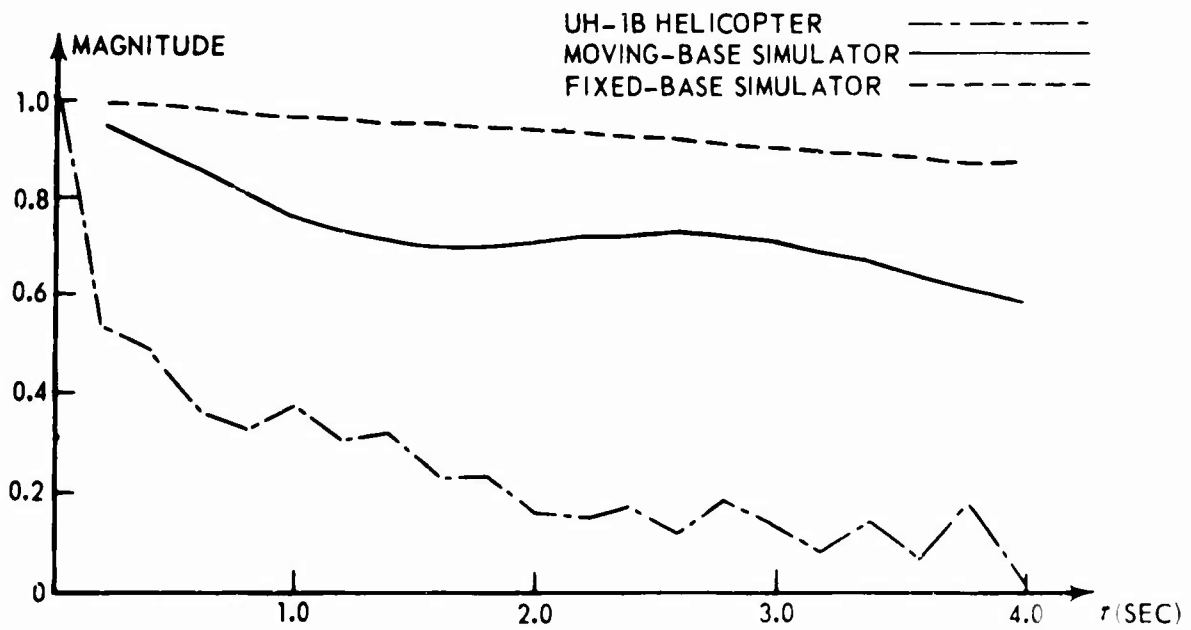

Figure 30. ACF of the Fore/Aft Stick Position for the Steady-State Descent at 70 Knots.

The pitch attitude ACFs of the acceleration and maximum power takeoff maneuvers are very similar for the aircraft and the simulator. Unfortunately, this is caused simply by the fact that the period of the pitch oscillation that was typical for the simulator, but not present for the aircraft, was longer than the maximum time shift τ shown. However, a small indication of this simulator oscillation is given in the traces for the fixed-based simulator (see Figure 31).

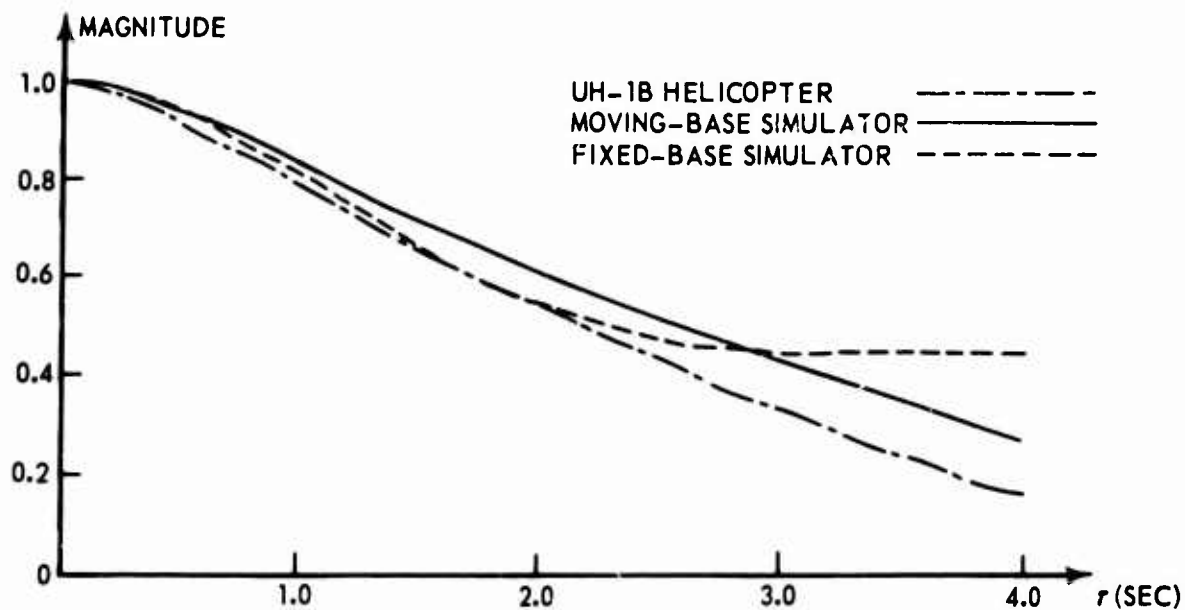

Figure 31. ACF of the Pitch Attitude for the Maximum Power Takeoff.

The pitch attitude ACFs of the three steady-state maneuvers reflect what has been said for the control activity. The moving-base simulator shows a very small pitch oscillation in a period of 3 sec. The actual pitch attitude deviations were smaller in the simulator than in the aircraft due to the absence of external disturbances (see Figure 32).

From the ACFs of the approach maneuver, it is seen again that the aircraft was changing pitch attitude more rapidly than the simulator. The dynamic simulator is revealed to be the most stable condition (see Figure 33).

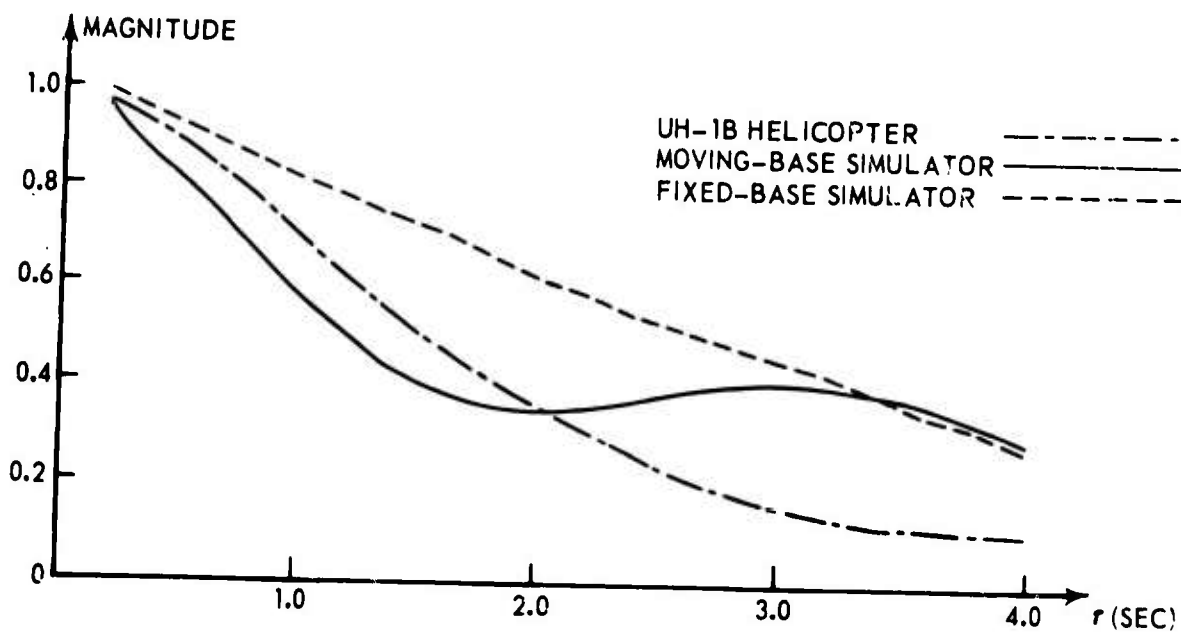

Figure 32. ACF of the Pitch Attitude for the 70-Knot Descent.

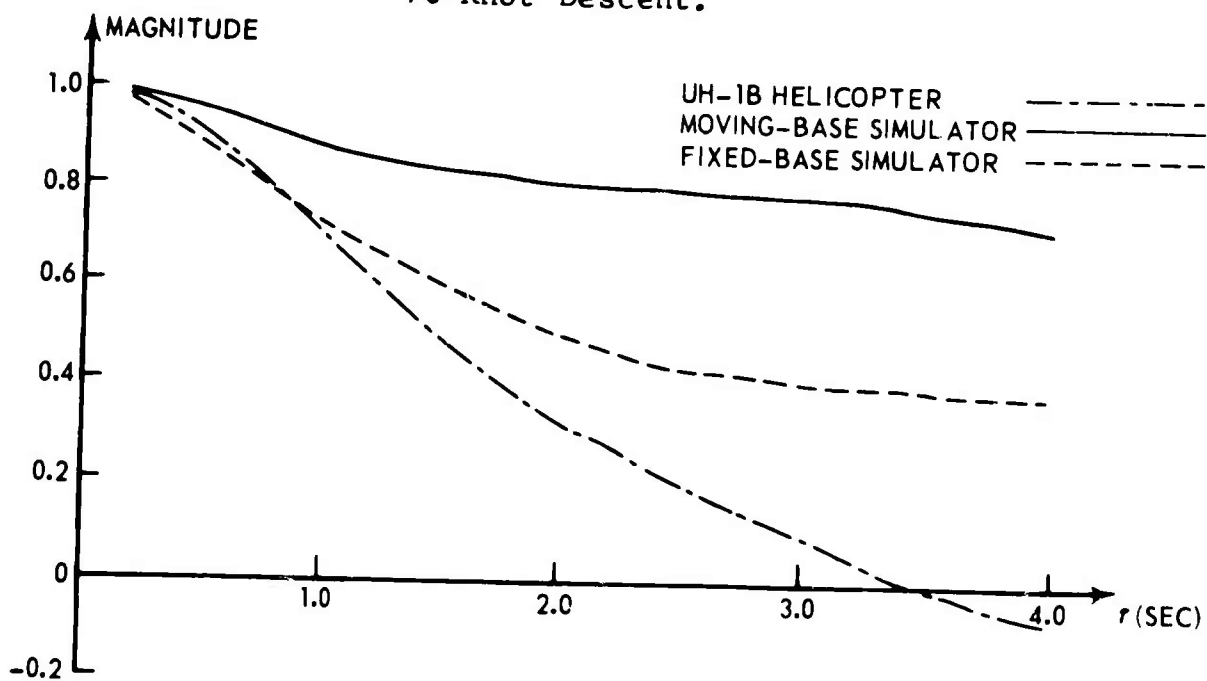

Figure 33. ACF of the Pitch Attitude for the Landing Approach.

b. Roll and Yaw Channel

The ACFs of roll and yaw controls depict the same basic trends as the pitch channel. Figures containing these ACFs for the acceleration and maximum power takeoff maneuvers are practically identical for simulator and aircraft. The shapes of these curves are mainly determined by the coupling effects described earlier (see Figure 34).

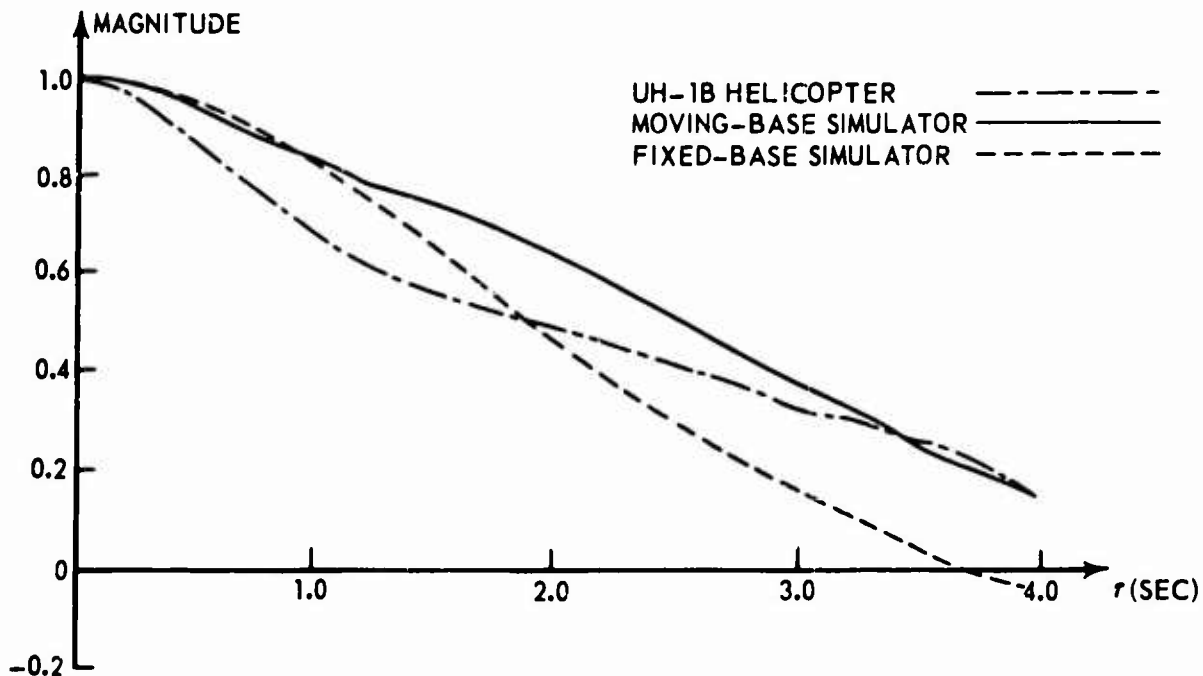

Figure 34. ACF of the Roll Attitude for the Maximum Power Takeoff.

The steady-state maneuvers all have very similar ACFs. The one for cruise climb is shown in Figure 35.

It can be seen that the aircraft exhibits a roll oscillation lasting a period of approximately 3 sec. The same frequency is contained in the dynamic simulator trace but not in the fixed-base simulator curve. In the descent, this oscillation disappears. However, in the approach in which the rate of descent was approximately 500 ft/min, the aircraft still had a slight tendency to oscillate in roll, whereas this did not occur in the dynamic or fixed-base simulator (see Figure 36).

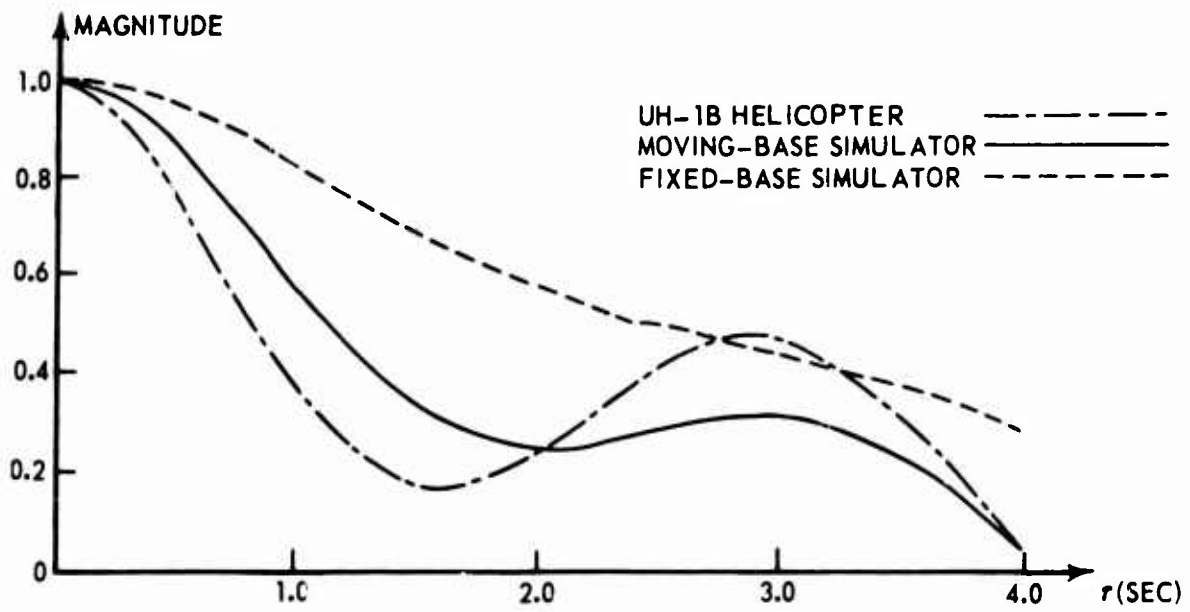

Figure 35. ACF of the Roll Attitude for the Steady-State Climb at 70 Knots.

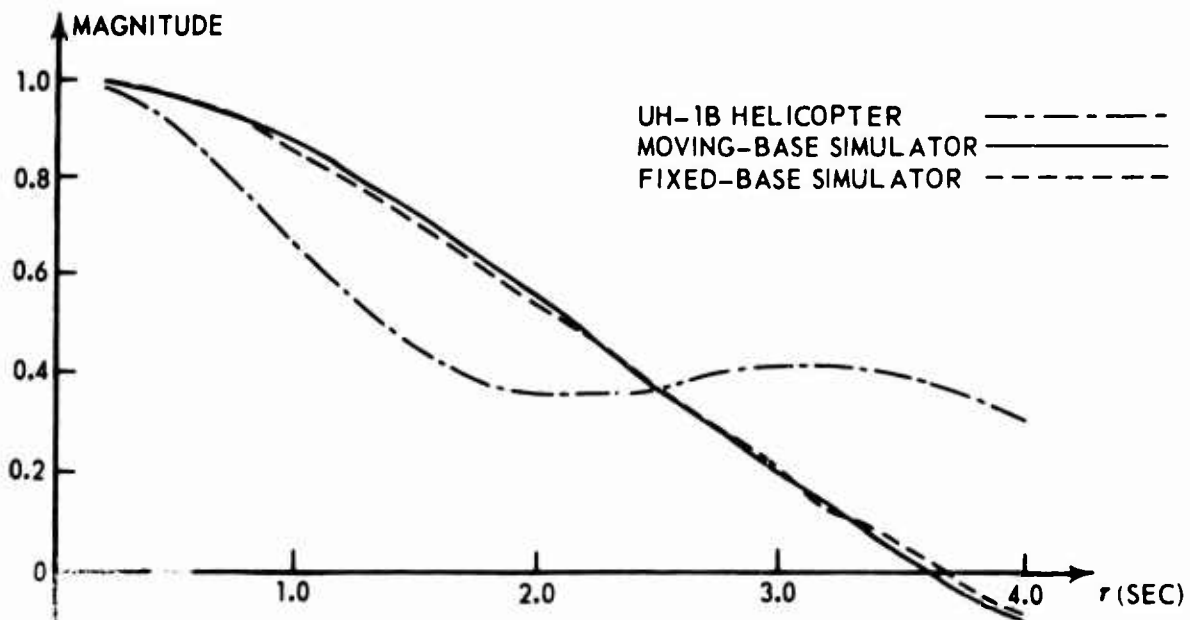

Figure 36. ACF of the Roll Attitude for the Landing Approach.

The yaw channel is so closely coupled with the roll channel that all statements that apply to the roll channel are pertinent to the yaw channel.

2. HOVER

In the lateral channel no influence of motion can be detected from the ACFs of roll attitude when shown as an average for all pilots (see Figure 37).

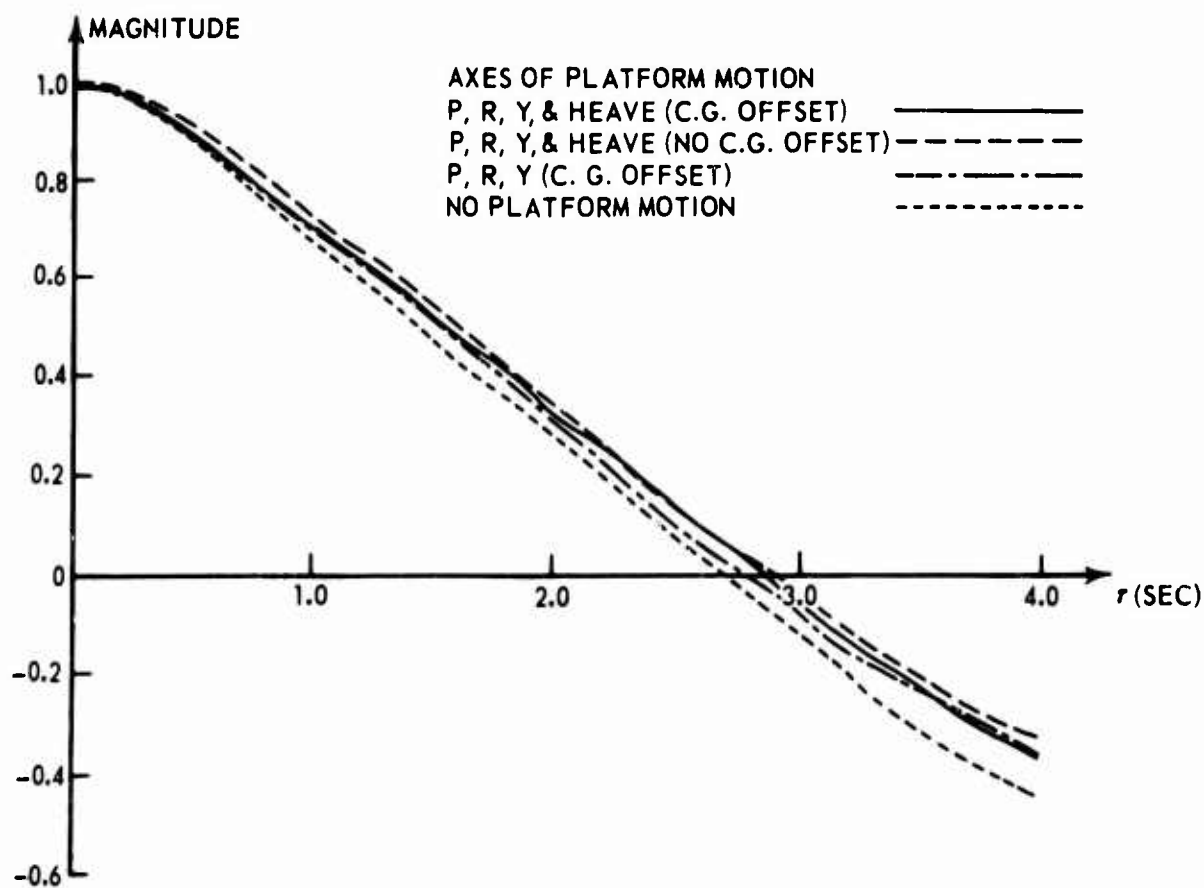

Figure 37. ACF of the Roll Attitude in Hover.

One exception shown is the lateral cyclic deflections in the case of motion condition 3 (see Figure 38) which shows a small harmonic component. This condition differed from condition 1 only in that it lacked the heave channel. Since no coupling between heave and roll was present, it must be concluded that the oscillatory component of motion condition 3 does not indicate a significant difference.

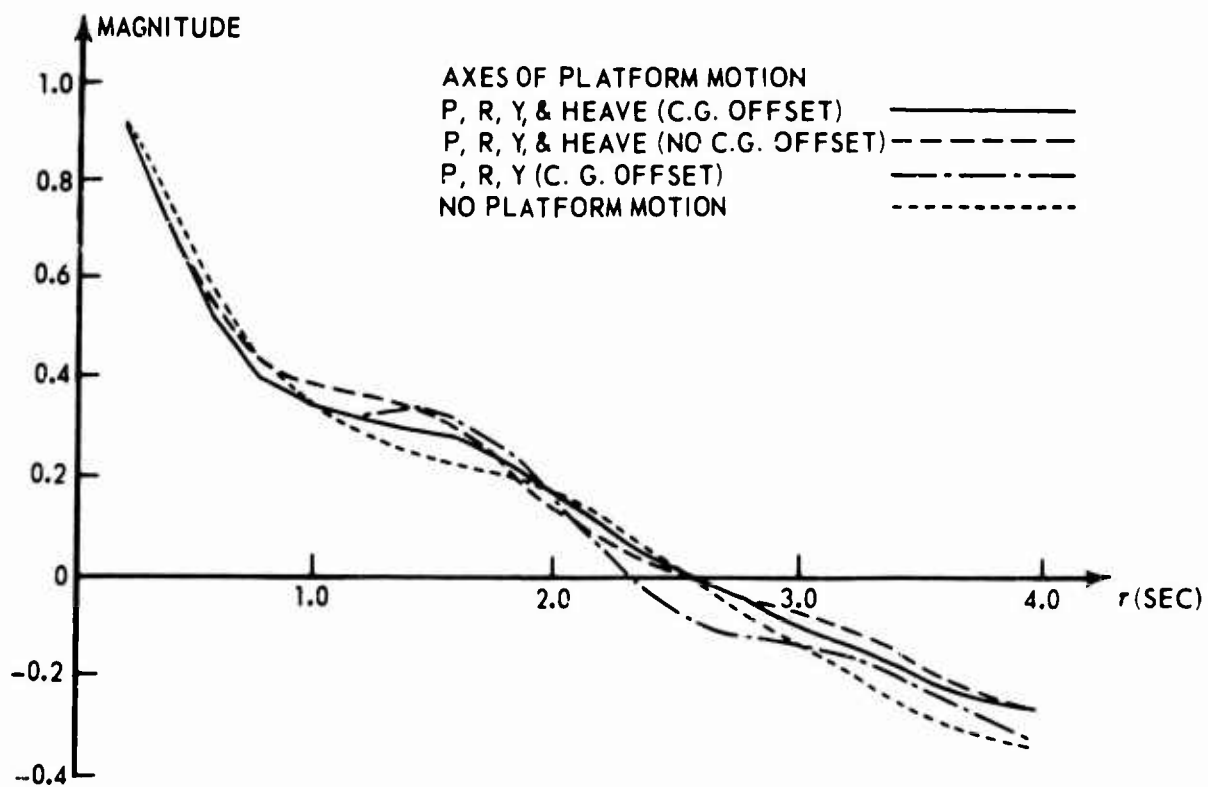

Figure 38. ACF of the Lateral Stick Deflection in Hover.

C. ERROR PARAMETER ANALYSIS

1. FORWARD FLIGHT

The coefficients of correlation obtained in the first schedule (comparisons of the dynamic, static simulator and the UH-1B flight test) are shown in Table V.

TABLE V. COEFFICIENTS OF CORRELATION FOR THE THREE ERROR PARAMETERS FOR SIMULATOR AND AIRCRAFT.			
Error Parameter	Correlation Coefficients		
	Static Simulator vs Dyn Simulator	Static Simulator vs UH-1B	Dyn Simulator vs UH-1B
$\Sigma e $.702	.504	.631
$\Sigma(e /w)$.721	.392	.349
$(\Sigma e) (\Sigma w)$.780	.430	.477

These coefficients of correlation were obtained by pairing the score for a given individual on a given maneuver in one condition (i.e., aircraft or simulator) with the score of the same individual on the same maneuver in a second condition, etc. Some of the coefficients of correlation are of a very respectable magnitude indicating that there is indeed a very strong relationship in what happens between conditions for particular individuals and maneuvers. The correlations between the two simulator conditions are relatively high, as might be expected. It will be noted that the correlations between the dynamic simulator and the UH-1B are somewhat larger than between the static simulator and the UH-1B.

Between the methods of measurement there is less consistency, although it can be said that the idea of efficiency being a better measurement than absolute error does not stand up. Only in the case of the dynamic, static correlations are the associations higher for the inefficiency measurements.

2. HOVER

The correlations obtained for the second schedule (standard UH-1B equations vs simplified equations in the simulator) are shown in Table VI. These correlations represent the hover mode only for two simulator conditions. No aircraft hover data were available for these comparisons. The correlations contained in Table VI were obtained by keeping the individual pilot-trial scores separated.

TABLE VI. COEFFICIENTS OF CORRELATION FOR THE THREE ERROR PARAMETERS FOR TWO TYPES OF SIMULATOR EQUATIONS OF MOTION.

Subject	$\Sigma e $	$\Sigma(e w)$	$(\Sigma e)(\Sigma w)$
1	.353	.510	.480
2	.381	.528	.525
3	.149	.380	.752
4	.296	.148	.632

These correlations are generally lower than those of the first schedule due to the smaller number of associations. The measurement $(\Sigma|e|)(\Sigma w)$ seems to have yielded the best prediction, while absolute error is lowest in prediction. It is not easy to reconcile these differences.

Some of the discrepancies are perhaps attributable to differences in the sensitivity of measurements. The recording system in the aircraft was much less refined than the one used in the simulator. Added to this was the fact that during flight it was not possible to examine the recordings as they were being made. Thus, recording malfunction could not be corrected. Although questionable data were not used in this analysis, the absence of recordings under some circumstances tended to make the analysis less complete than it would have been otherwise. This would tend to reduce the overall similarity between the two sets of data.

At this point it would be premature to conclude that the indices of inefficiency are superior or inferior to absolute error. Further investigations along these lines are recommended.

SECTION VI. CONCLUSIONS AND RECOMMENDATIONS

From the results presented here it is concluded that in forward flight maneuvers, the motion of the simulator platform has a noticeable effect only under flight conditions that include large attitude changes. The pilot-simulator loop, with platform motion conditions, behaves in a manner more closely related to the actual aircraft than to the simulator when there was no platform motion. In hover, motion reduces the amount of overcontrolling; i.e., attitude is held more precisely. The addition of heave motion, when used for vertical aircraft c.g. displacements, did not aid the steady-state hover attitude control.

Simplification in the simulator equations of motion shows that the pilot's control behavior changes immediately even with minor changes in the equations. Any simplification of equations that alters the dynamic behavior of the simulator in a flight regime of interest must be rejected when this simulator is used for handling-qualities investigations.

While many pertinent questions relating to the most efficient use of simulators have been partially answered in the present research, additional research of the present variety is required if simulators are to fill their role as a design aid. Simulator designers have operated on the assumption that greater fidelity is always useful. Results of this study lend support to this assumption. The data, however, represent a small number of the pertinent variables that needed further examination.

Additional basic research is needed not only in the individual areas of display, control and motion fidelity, but above all a system is needed for systematically measuring the fidelity of simulation that will be required to provide data for the design engineers. At the present, only such things can be said as, "in terms of System A, Simulator S₁ is nearer the actual system than Simulator S₂, but in terms of System B the reverse may hold true." Since there is no convenient way of indexing how nearly a simulator resembles a system in terms of fidelity, it is difficult to bring the variable into descriptive association with how accurately the simulator may be used as a substitute of the system (its validity).

It has also been indicated in this study that there is a great need to obtain valid performance measures. This area is equally important in the task of determining overall simulator effectiveness, especially in the validity of total pilot workload.

The basic research should start with simple systems and through testing and analysis readjust the scales of simulation

fidelity and performance until they begin to yield more systematic results than are presently available. As these scales become more sensitized, greater complexity in the system can be introduced until a point is reached where problems can be handled that are pertinent to advanced aircraft concepts. This approach cannot be considered as a simple critical experiment. The effort suggests a systematic exploration of a number of interacting factors. The research should begin by measuring fidelity of control relationships with emphasis on such factors as lag, cross coupling and gain, with simultaneous attention given to the value of selected performance measures.

REFERENCES CITED

1. Feddersen, W.E., The Role of Motion Information and its Contribution to Simulation Validity, Bell Helicopter Company ANIP Technical Report No. D228-429-001, April 1962.
2. Emery, J. H., Koch, C. A., and Curtin, J. G., Contact Analog Simulator Evaluation: Investigations of Director Symbols, Display Alteration, and the Presentation of Secondary Flight Information, Bell Helicopter Company JANAIR Technical Report No. D228-420-008, January 1967.
3. Salmirs, Seymour, and Tapscott, Robert J., The Effects of Various Combinations of Damping and Control Power on Helicopter Handling Qualities During Both Instrument and Visual Flight, NASA TN D-58, October 1959.
4. Solodovnikov, V.V., Introduction to the Statistical Dynamics of Automatic Control Systems, Dover Publications, Inc., New York, New York, 1960.
5. Schweizer, G., Jr., Pilot Behavior in VTOL Aircraft, NATO AGARD Report 521, October 1965.
6. Fitts, Paul M., Bennett, William F., and Bahrick, Harry P., "Application of Auto-Correlation and Cross-Correlation Analysis to the Study of Tracking Behavior", Symposium on Air Force Human Engineering, Personnel and Training Research, Glenn Finch and Frank Cameron, Editors, published by National Academy of Sciences, National Research Council, Washington, D.C., 1955.
7. Hoffmann, Errol R., and Joubert, Peter N., "The Effects of Changes in Some Vehicle Handling Variables on Driver Steering Performance", Human Factors Journal, Vol. 8, No. 3, June 1966.
8. Crowson, Henry L., "An Error Analysis in the Digital Computation of the Autocorrelation Function", AIAA Journal, Vol. 1, No. 2, February 1963.
9. Elam, C. B., and Emery, J. H., Effect of Stimulus Ambiguity in the Display of Attitude Information, Bell Helicopter Technical Report 228-421-013, 1962.
10. Elam, C. B., and Abbott, B. A., Research on Utilization of Part Task Spatial Orientation Information in the Dynamic Simulator, Bell Helicopter Technical Report 299-099-284, NASA Contract NASW-439, June 1965.

APPENDIX I
DATA PROCESSING PROCEDURE

TABLE VII. FLIGHT/SIMULATOR CORRELATION STUDY - CODING OF TEST CONDITIONS													
		Simulator						UH-1B					
		Full Motion			No Motion			Helicopter					
		Pilot			Pilot			Pilot					
		1	2	3	1	2	3	1	2	3			
<u>Fore/Aft Stick Pitch Attitude</u>	M A N	1	AAA	BAA	CAA	DAA	EAA	FAA	GAA	HAA	IAA		
			AAE	BAE	CAE	DAE	EAE	FAE	GAE	HAE	IAE		
			ABA	BBA	CBA	DBA	EBA	FBA	GBA	HBA	IBA		
	E U V	2	ABE	BBE	CBE	DBE	EBE	FBE	GBE	HBE	IBE		
			ACA	BCA	CCA	DCA	ECA	FCA	GCA	HCA	ICA		
			ACE	BCE	CCE	DCE	ECE	FCE	GCE	HCE	ICE		
	E R	4	ADA	BDA	CDA	DDA	EDA	FDA	GDA	HDA	IDA		
			ADE	BDE	CDE	DDE	EDE	FDE	GDE	HDE	IDE		
			AEA	BEA	CEA	DEA	EEA	FEA	GEA	HEA	IEA		
		5	AEE	BEE	CEE	DEE	EEE	FEE	GEE	HEE	IEE		
			M A N	1	AAB	BAB	CAB	DAB	EAB	FAB	GAB	HAB	IAB
					AAF	BAF	CAF	DAF	EAF	FAF	GAF	HAF	IAF
	ABB	BBB			CBB	DBB	EBB	FBB	GBB	HBB	IBB		
	E U V	2	ABF	BBF	CBF	DBF	EBF	FBF	GBF	HBF	IBF		
			ACB	BCB	CCB	DCB	ECB	FCB	GCB	HCB	ICB		
ACF			BCF	CCF	DCF	ECF	FCF	GCF	HCF	ICF			
E R	4	ADB	BDB	CDB	DDB	EDB	FDB	GDB	HDB	IDB			
		ADF	BDF	CDF	DDF	EDF	FDG	GDF	HDF	IDF			
		AEB	BEB	CEB	DEB	EEB	FEB	GEB	HEB	IEB			
	5	AEF	BEF	CEF	DEF	EEF	FEF	GEF	HEF	IEF			
		M A N	1	AAC	BAC	CAC	DAC	EAC	FAC	GAC	HAC	IAC	
				AAG	BAG	CAG	DAG	EAG	FAG	GAG	HAG	IAG	
ABC	BBC			CBC	DBC	EBC	FBC	GBC	HBC	IBC			
E U V	2	ABG	BBG	CBG	DBG	EBG	FBG	GBG	HBG	IBG			
		ACC	BCC	CCC	DCC	ECC	FCC	GCC	HCC	ICC			
		ACG	BCG	CCG	DCG	ECG	FCG	GCG	HCG	ICG			
E R	4	ADC	BDC	CDC	DDC	EDC	FDC	GDC	HDC	IDC			
		ADG	BDG	CDG	DDG	EDG	FDG	GDG	HDG	IDG			
		AEC	BDC	CEC	DEC	EEC	FEC	GEC	HEC	IEC			
	5	AEG	BDG	CEG	DEG	EEG	FEG	GEG	HEG	IEG			

TABLE VIII. FLIGHT/SIMULATOR CORRELATION STUDY - NUMBER OF SAMPLE POINTS FOR EACH TEST CONDITION*

		Simulator						UH-1B			
		Full Motion			No Motion			Helicopter			
		Pilot			Pilot			Pilot			
		1	2	3	1	2	3	1	2	3	
<u>Fore/Aft Stick</u> <u>Pitch Attitude</u>	M	1	361	481	321	491	411	361	131	161	161
			145	193	129	197	165	145	53	65	65
	A	2	381	261	181	271	161	161	101	96	111
			153	105	73	109	65	65	41	39	45
	N	3	261	331	211	241	191	311	131	91	91
			105	133	85	97	77	125	53	37	37
	U	4	281	231	241	201	**	211	131	111	161
			113	93	97	81	**	85	53	45	65
	V	5	361	361	321	361	401	391	151	281	161
			145	145	129	145	161	157	61	113	65
<u>Lateral Stick</u> <u>Roll Attitude</u>	M	1	361	481	321	491	411	361	131	161	161
			145	193	129	197	165	145	53	65	65
	A	2	381	261	181	271	161	161	101	96	111
			153	105	73	109	65	65	41	39	45
	N	3	261	331	211	241	191	311	131	91	91
			105	133	85	97	77	125	53	37	37
	U	4	281	231	241	201	**	211	131	111	161
			113	93	97	81	**	85	53	45	65
	V	5	361	361	321	361	401	391	151	281	161
			145	145	129	145	161	157	61	113	65
<u>Yaw Pedals</u> <u>Heading</u>	M	1	361	481	321	491	411	361	131	161	161
			145	193	129	197	165	145	53	65	65
	A	2	381	261	181	271	161	161	101	96	111
			153	105	73	109	65	65	41	39	45
	N	3	261	331	211	241	191	311	131	91	91
			105	133	85	97	77	125	53	37	37
	U	4	281	231	241	201	**	211	131	111	161
			113	93	97	81	**	85	53	45	65
	V	5	361	361	321	361	401	391	151	281	161
			145	145	129	145	161	157	61	113	65

* All attitude data were interpolated to increase the number of sample points to equal the control stick data.

** No data available.

TABLE IX. SIMULATOR MOTION STUDY - CODING OF TEST CONDITIONS*										
		Simulator Equations of Motion								
		UH-1B Original				UH-1B Simplified				
		Pilots				Pilots				
		4	5	6	7	4	5	6	7	
<u>Fore/Aft Stick</u> <u>Pitch Attitude</u>	P L A T F O R M M O T I O N	1	11A	21A	31A	41A	51A	61A	71A	81A
			11E	21E	31E	41E	51E	61E	71E	81E
		2	12A	22A	32A	42A	52A	62A	72A	82A
			12E	22E	32E	42E	52E	62E	72E	82E
	3	13A	23A	33A	43A	53A	63A	73A	83A	
		13E	23E	33E	43E	53E	63E	73E	83E	
	4	14A	24A	34A	44A	54A	64A	74A	84A	
		14E	24E	34E	44E	54E	64E	74E	84E	
<u>Lateral Stick</u> <u>Roll Attitude</u>	P L A T F O R M M O T I O N	1	11B	21B	31B	41B	51B	61B	71B	81B
			11F	21F	31F	41F	51F	61F	71F	81F
		2	12B	22B	32B	42B	52B	62B	72B	82B
			12F	22F	32F	42F	52F	62F	72F	82F
	3	13B	23B	33B	43B	53B	63B	73B	83B	
		13F	23F	33F	43F	53F	63F	73F	83F	
	4	14B	24B	34B	44B	54B	64B	74B	84B	
		14F	24F	34F	44F	54F	64F	74F	84F	
<u>Yaw Pedals</u> <u>Heading</u>	P L A T F O R M M O T I O N	1	11C	21C	31C	41C	51C	61C	71C	81C
			11G	21G	31G	41G	51G	61G	71G	81G
		2	12C	22C	32C	42C	52C	62C	72C	82C
			12G	22G	32G	42G	52G	62G	72G	82G
	3	13C	23C	33C	43C	53C	63C	73C	83C	
		13G	23G	33G	43G	53G	63G	73G	83G	
	4	14C	24C	34C	44C	54C	64C	74C	84C	
		14G	24G	34G	44G	54G	64G	74G	84G	

* All data were from 2-minute hover flights. There were 240 sample points in each cell. All data were interpolated to increase the number of sample points to 600 points per condition.

TABLE X. INSTRUMENTATION OSCILLOGRAPH RECORDS - SCALE FACTORS FOR TIME HISTORY TRACE DEFLECTIONS

Channel	Simulator Records		Flight Records	
	Reference Value (Units)	Sensitivity (Per Unit)	Reference Value (In.)	Sensitivity (Per In.)
Fore/Aft Cyclic Control Stick	5.0	1.43 in.	1.70	4.76 in.
Lateral Cyclic Control Stick	5.0	.86 in.	1.79	4.00 in.
Directional Foot Pedals	5.0	2.425 in.	0.82	3.87 in.
Pitch Attitude	5.0	2.865 deg	2.30	8.406 deg
Roll Attitude	5.0	5.75 deg	2.90	12.05 deg
Heading Control	5.0	5.40 deg	2.34	12.59 deg

APPENDIX II

PROCEDURE FOR NORMALIZING AUTOCORRELATION
AND CROSS CORRELATION FUNCTIONS

The normalized ACF is usually computed by first performing the integration

$$ACF(\tau) = \lim_{T \rightarrow \infty} \frac{1}{T} \int_0^{+T} f(t) \cdot f(t - \tau) dt - \frac{\overline{f(t)}^2}{2} \quad (4)$$

and then by subtracting out the square of the average of $f(t)$, i.e., $\overline{f(t)}^2$. The same result is obtained when $\overline{f(t)}$ is subtracted out of the time function first, and the correlation process becomes

$$ACF(\tau) = \lim_{T \rightarrow \infty} \frac{1}{T} \int_0^T \left[f(t) - \overline{f(t)} \right] \left[f(t - \tau) - \overline{f(t)} \right] dt \quad (5)$$

$$= \lim_{T \rightarrow \infty} \frac{1}{T} \int_0^T f(t)f(t - \tau)dt - \lim_{T \rightarrow \infty} \frac{\overline{f(t)}}{T} \int_0^T f(t)dt \quad (6)$$

$$- \lim_{T \rightarrow \infty} \frac{\overline{f(t)}}{T} \int_0^T f(t - \tau)dt + \lim_{T \rightarrow \infty} \frac{\overline{f(t)}^2}{T} \int_0^T dt$$

$$= \lim_{T \rightarrow \infty} \frac{1}{T} \int_0^T f(t)f(t - \tau)dt - \overline{f(t)}^2 = ACF(\tau) \quad (7)$$

since

$$\lim_{T \rightarrow \infty} \frac{\overline{f(t)}^2}{T} \int_0^T dt = \lim_{T \rightarrow \infty} \frac{\overline{f(t)}}{T} \int_0^T f(t - \tau)dt \quad (8)$$

The proof for the same procedure for the CCF is quite analogous; i.e.,

$$CCF(\tau) = \lim_{T \rightarrow \infty} \frac{1}{T} \int_0^T \left[f_1(t) - \overline{f_1(t)} \right] \left[f_2(t - \tau) - \overline{f_2(t)} \right] dt \quad (9)$$

$$= \lim_{T \rightarrow \infty} \frac{1}{T} \int_0^T f_1(t) f_2(t - \tau) dt - \lim_{T \rightarrow \infty} \frac{\overline{f_2(t)}}{T} \int_0^T f_1(t) dt \quad (10)$$

$$- \lim_{T \rightarrow \infty} \frac{\overline{f_1(t)}}{T} \int_0^T f_2(t - \tau) dt + \lim_{T \rightarrow \infty} \frac{\overline{f_1(t)} \cdot \overline{f_2(t)}}{T} \int_0^T dt$$

$$= \lim_{T \rightarrow \infty} \frac{1}{T} \int_0^T f_1(t) f_2(t - \tau) dt - \overline{f_2(t)} \cdot \overline{f_1(t)} \quad (11)$$

since

$$\lim_{T \rightarrow \infty} \frac{1}{T} (\overline{f_1(t)} \cdot \overline{f_2(t)}) \int_0^T dt = \lim_{T \rightarrow \infty} \frac{\overline{f_1(t)}}{T} \int_0^T f_2(t - \tau) dt \quad (12)$$

APPENDIX III
VALUES USED TO OBTAIN COEFFICIENTS OF CORRELATION

TABLE XI. FLIGHT/SIMULATOR CORRELATION STUDY - SCORES BASED UPON THE MEASUREMENT $\sum e $											
		Simulator						UH-1B			
		Full Motion			No Motion			Helicopter			
		Pilot			Pilot			Pilot			
		1	2	3	1	2	3	1	2	3	
Pitch Attitude	MANEUVER	1	1002	1422	1218	1333	1342	1162	1729	2194	2552
	2	504	637	341	495	472	526	336	718	605	
	3	29	152	52	106	106	59	138	153	240	
	4	34	158	36	14	-	40	164	128	82	
	5	82	148	139	104	78	131	88	128	239	
Roll Attitude	MANEUVER	1	993	990	62	1795	1340	796	190	417	207
	2	1179	361	212	366	1030	423	135	235	163	
	3	171	789	242	340	251	363	96	161	111	
	4	491	215	301	227	-	269	133	134	98	
	5	396	744	573	641	1414	450	147	180	105	
Yaw Attitude	MANEUVER	1	162	118	206	155	173	212	253	906	385
	2	244	329	357	98	90	510	155	468	113	
	3	62	13	20	-	18	20	65	90	173	
	4	52	42	43	59	-	87	115	95	176	
	5	116	100	0	88	29	47	360	183	224	

TABLE XII. FLIGHT/SIMULATOR CORRELATION STUDY - SCORES
BASED UPON THE MEASUREMENT $\Sigma(e|v)$

		Simulator									UH-1B		
		Full Motion Pilot			No Motion Pilot			Helicopter Pilot			Helicopter Pilot		
		1	2	3	1	2	3	1	2	3	1	2	3
		1	2	3	1	2	3	1	2	3	1	2	3
Fore/Art Stick Pitch Attitude	M	1	1.050	.589	1.188	.833	.688	1.978	.862	1.860	12.982		
	A	2	.436	1.531	1.121	.306	.995	2.262	1.985	2.780	3.058		
	N	3	.000	.047	.017	.030	.011	.006	.515	.542	1.312		
	E	4	.006	.085	.001	.000	-	.001	.632	.576	.329		
	R	5	.002	.013	.053	.000	.004	.030	.329	.311	.526		
Lateral Stick Roll Attitude	M	1	4.690	1.985	1.508	4.486	3.601	1.882	.543	1.076	.472		
	A	2	2.201	1.762	1.112	.605	7.224	.973	.317	.367	.411		
	N	3	.084	1.258	.478	.151	.213	.257	.111	.210	.307		
	E	4	.108	.326	.250	.094	-	.428	.273	.205	.172		
	R	5	.328	1.010	1.103	.730	2.826	.506	.143	.154	.047		
Yaw Pedals Heading	M	1	.562	.341	.209	.226	.388	.176	.504	1.252	.735		
	A	2	.333	.812	.810	.164	.542	1.136	.229	.434	.247		
	N	3	.032	.028	.025	.000	.028	.036	.043	.013	.039		
	E	4	.017	.069	.012	.008	-	.016	.000	.033	.148		
	R	5	.013	.042	.001	.024	.018	.006	.035	.078	.022		

TABLE XIII. FLIGHT/SIMULATOR CORRELATION STUDY - SCORES BASED UPON THE MEASUREMENT ($\sum e \times \sum w$)									
	Simulator								
	Full Motion Pilot			No Motion Pilot			UH-1B Helicopter Pilot		
	1	2	3	1	2	3	1	2	3
Fore/Art Stick Pitch Attitude M A N E U V E R	152,704	126,419	179,289	182,354	118,498	258,545	165,744	220,277	320,531
	57,960	85,421	40,613	21,611	21,542	47,008	20,536	48,752	30,546
	1,702	4,166	867	11,363	531	590	8,894	6,724	9,652
	283	3,991	111	2	-	28	9,940	6,387	4,052
	273	1,164	5,632	74	520	3,293	8,060	7,910	37,475
Lateral Stick Roll Attitude M A N E U V E R	575,940	458,469	17,471	901,987	503,304	207,756	9,207	22,626	10,205
	291,802	107,570	34,640	31,842	161,607	28,527	4,063	6,077	4,161
	6,703	139,416	15,183	7,017	7,033	21,903	1,795	2,194	2,378
	8,160	15,146	12,964	2,456	-	16,115	3,661	2,153	1,979
	33,129	92,241	87,038	88,329	304,010	60,840	3,185	3,834	3,685
Yaw Pedals Heading M A N E U V E R	65,172	32,308	14,819	49,584	59,287	20,992	9,064	29,164	16,735
	50,239	63,102	29,506	9,898	12,058	37,928	2,359	8,569	2,018
	2,330	2,614	315	-	592	105	741	139	301
	1,303	3,174	503	381	-	632	.000115	282	1,578
	1,546	4,911		3,200	1,793	987	1,022	1,983	2,961

TABLE XIV. SIMULATOR MOTION STUDY - SCORES BASED UPON THE MEASUREMENT $\sum |e|$

		Simulator Equations of Motion							
		UH-1B Original				UH-1B Simplified			
		Pilots				Pilots			
Pitch Attitude	P L M L A O A T T F I O R M N M	4	5	6	7	4	5	6	7
Pitch Attitude	1	161	229	436	155	172	332	426	415
	2	167	255	270	302	188	226	357	388
	3	244	449	241	131	253	307	439	311
	4	215	478	281	363	184	374	659	510
Roll Attitude	1	381	695	1360	238	421	1098	1029	932
	2	350	739	-	494	404	655	1047	538
	3	402	749	955	339	357	561	1298	737
	4	335	1390	1181	861	1865	1448	4310	1527
Heading	1	642	140	-	687	535	946	1171	1085
	2	574	272	145	798	572	680	-	846
	3	537	277	146	561	725	639	-	932
	4	699	41	187	883	909	208	-	907

TABLE XV. SIMULATOR MOTION STUDY - SCORES BASED UPON THE MEASUREMENT $\Sigma(e w)$													
		Simulator Equations of Motion											
		UH-1B Original Pilots				UH-1B Simplified Pilots							
		4	5	6	7	4	5	6	7	4	5	6	7
Fore/Aft Stick Pitch Attitude	P L M	0.098	0.315	0.149	0.020	0.127	0.101	0.178	0.771				
	A T T	0.075	0.085	0.055	0.336	0.101	0.203	0.023	0.595				
	F I O	0.358	0.701	0.002	0.016	0.280	0.220	0.216	0.555				
	R N M	0.191	0.820	0.010	0.399	0.285	0.265	0.424	0.545				
Lateral Stick Roll Attitude	P L M	0.200	1.261	0.809	0.051	0.386	1.792	0.280	1.101				
	A T T	0.132	1.369	-	0.243	0.205	0.676	0.431	0.601				
	F I O	0.368	0.958	0.324	0.108	0.148	0.427	0.436	0.837				
	R N M	0.205	3.444	0.518	0.563	1.891	1.997	4.463	0.951				
Yaw Pedals Heading	P L M	0.227	0.058	-	0.049	0.259	0.303	0.007	0.328				
	A T T	0.188	0.089	0.036	0.080	0.276	0.154	-	0.162				
	F I O	0.242	0.138	0.037	0.036	0.296	0.219	-	0.268				
	R N M	0.254	0.014	0.057	0.322	0.368	0.190	-	0.185				

TABLE XVI. SIMULATOR MOTION STUDY - SCORES BASED UPON THE MEASUREMENT ($\Sigma|e|$) (Σw)

		Simulator Equations of Motion								
		UH-1B Original				UH-1B Simplified				
		Pilots				Pilots				
		4	5	6	7	4	5	6	7	
Fore/Aft Stick Pitch Attitude	P L A T T I O N F O R M	M 1	218	475	97	43	247	101	149	525
		M 2	148	109	68	323	206	344	24	513
		M 3	478	485	3	54	392	218	128	532
		M 4	276	558	8	279	523	254	195	264
Lateral Stick Roll Attitude	P L A T T I O N F O R M	M 1	177	558	193	61	315	558	88	336
		M 2	129	635	-	167	143	377	107	335
		M 3	280	393	111	89	133	223	110	329
		M 4	206	759	122	181	325	418	263	180
Yaw Pedals Heading	P L A T T I O N F O R M	M 1	109	137	-	24	155	99	1	93
		M 2	1155	106	92	24	141	75	-	69
		M 3	143	131	95	13	140	128	-	103
		M 4	128	102	115	129	147	280	-	71

Unclassified

Security Classification

DOCUMENT CONTROL DATA - R & D		
<i>(Security classification of title, body of abstract and indexing annotation must be entered when the overall report is classified)</i>		
1. ORIGINATING ACTIVITY (Corporate author) Bell Helicopter Company P. O. Box 482 Fort Worth, Texas 76101		2a. REPORT SECURITY CLASSIFICATION Unclassified 2b. GROUP
3. REPORT TITLE A Study of the Validity of Ground-Based Simulation Techniques for the UH-1B Helicopter		
4. DESCRIPTIVE NOTES (Type of report and inclusive dates) Final Technical Report		
5. AUTHOR(S) (First name, middle initial, last name) John H. Emery Walter G. O. Sonneborn Claude B. Elam		
6. REPORT DATE December 1967	7a. TOTAL NO. OF PAGES 80	7b. NO. OF REFS 10
8a. CONTRACT OR GRANT NO. DA 44-177-AMC-463(T) b. PROJECT NO. 1F125901A14233 c. d.	9a. ORIGINATOR'S REPORT NUMBER(S) USAAVLABS Technical Report 67-72 9b. OTHER REPORT NO(S) (Any other numbers that may be assigned this report) BHC No. 299-099-350	
10. DISTRIBUTION STATEMENT This document has been approved for public release and sale; its distribution is unlimited.		
11. SUPPLEMENTARY NOTES	12. SPONSORING MILITARY ACTIVITY U.S. Army Aviation Materiel Labs Ft. Eustis, Virginia	
13. ABSTRACT The work explored the characteristics of some simulator and flight data which were collected in a UH-1B helicopter and a ground-based simulated version of the same. Analytical treatments are described and applied to these data. They are autocorrelation and cross correlation functions, pilot error and pilot efficiency. Results are reported on the effectiveness of certain simulator variables and performance measurement techniques.		

DD FORM 1473

REPLACES DD FORM 1473, 1 JAN 64, WHICH IS OBSOLETE FOR ARMY USE.

Unclassified
Security Classification

Unclassified
Security Classification

14. KEY WORDS	LINK A		LINK B		LINK C	
	ROLE	WT	ROLE	WT	ROLE	WT
UH-1B Helicopter Stability Control Simulation Techniques, Ground-Based						

Unclassified
Security Classification

10324-67