

FOREIGN TECHNOLOGY DIVISION



DDC
RECEIVED
SEP 23 1968
RECEIVED
D

PHASE DIAGRAM OF THE ZrC-Mo SYSTEM

by

S. S. Ordan'yan, A. I. Avgustinik, and V. S. Vigdergauz



Distribution of this document is unlimited. It may be released to the Clearinghouse, Department of Commerce, for sale to the general public.

Reproduced by the
CLEARINGHOUSE
for Federal Scientific & Technical
Information Springfield Va. 22151

AD 574725

EDITED TRANSLATION

PHASE DIAGRAM OF THE ZrC-Mo SYSTEM

By: S. S. Ordan'yan, A. I. Avgustinik, and
V. S. Vigdergauz

English pages: 11

SOURCE: AN SSSR. Issledovaniya v Oblasti Khimii
Silikatov i Okislov, Sb. Statei. (Academy
of Sciences of the USSR. Investigation of
Silicate and Oxide Chemistry, Collection
of Articles), 1965, pp. 220-228.

Translated by: F. Dion/TDBRO-2

TT7002273

THIS TRANSLATION IS A RENDITION OF THE ORIGINAL FOREIGN TEXT WITHOUT ANY ANALYTICAL OR EDITORIAL COMMENT. STATEMENTS OR THEORIES ADVOCATED OR IMPLIED ARE THOSE OF THE SOURCE AND DO NOT NECESSARILY REFLECT THE POSITION OR OPINION OF THE FOREIGN TECHNOLOGY DIVISION.

PREPARED BY:

TRANSLATION DIVISION
FOREIGN TECHNOLOGY DIVISION
WP-APB, OHIO.

ITIS INDEX CONTROL FORM

| | | | | | | | |
|------------------------|--------------------|--|---------------|------------------------------|-------------------|-------------------------------|-----------------|
| 01 Acc Nr TT7002273 | | 68 Translation Nr FTD-HT-23-1034-67 | | 65 X Ref Acc Nr BC6022679 | | 76 Reel/Frame Nr 1882 1853 | |
| 97 Header Clas UNCL | 63 Clas UNCL, 0 | 64 Control Markings 0 | | | 94 Expansion | 40 Ctry Info UR | |
| 02 Ctry UR | 03 Ref 0000 | 04 Yr 65 | 05 Vol 000 | 06 Iss 000 | 07 B. Pg. 0220 | 45 B. Pg. 0228 | 10 Date NONE |

Transliterated Title

DIAGRAMMA SOSTOYANIYA ZRC—MO

09 English Title

PHASE DIAGRAM OF THE ZrC-Mo SYSTEM

43 Source

AN SSSR. ISSLEDOVANIYA V OBLASTI KHIMII SILIKATOV I OKISLOV. SBORNIK STATEY (RUSSIAN)

42 Author

ORDAN'YAN, S. S.

98 Document Location

16 Co-Author

AVGUSTINIK, A. I.

47 Subject Codes

11, 07

16 Co-Author

VIGDERGAUZ, V. S.

39 Topic Tags: heat resistant material, zirconium, carbon, molybdenum, titanium, tungsten, x ray diffraction, melting

16 Co-Author

NONE

16 Co-Author

NONE

ABSTRACT: To investigate the possibility of using as heat-resistant materials alloys consisting of ZrC bound by Mo, the quasi-binary section ZrC-Mo of the system Zr-C-Mo was studied. The constitutional diagram of the quasi-binary section was constructed on the basis of data obtained by Chem., x-ray diffraction, and metallographic study as well as of detns. of the temps. of the beginning of melting. The diagram was of the eutectic type, with the eutectic horizontal at 2520°K. The compn. of the eutectic was approx. $Zr_{0.189}Mo_{0.811}C_{0.189}$ (80% by wt. Mo). The soly. of Mo in ZrC increased with increasing temps., 1.2, 3.1, and 9.9 at. % at 2273, 2373, and 2520°K, resp., while the soly. of ZrC in Mo was insignificant. By analogy with the systems ZrC-Mo, TiC-Mo, TiC-W, and ZrC-W, the system HfC-W may also be expected to have a consitutional diagram of the eutectic type. The eutectic point of HfC-W was estd. at 3200°K, which is the highest for any known carbide-metal system.
English translation: 11 pages.

PHASE DIAGRAM OF THE ZrC-Mo SYSTEM

S. S. Ordan'yan, A. I. Avgustinik, and V. S. Vigdergauz

The development of heat-resistant materials of the cermet type using carbides of the transition metals as the refractory base is contingent on the study of the interaction of the base with the binder-metal, which must also be a refractory. The interaction of TiC with metals of the iron group and the more refractory metals Cr, Mo, W, V and Ta has been studied most thoroughly [1, 5]. The other carbides of group IV metals, ZrC and HfC, have been studied less thoroughly in this respect [6-10].

In this report we give the results of a study of the interaction of ZrC with molybdenum. The boundary systems in the ternary Zr-C-Mo system have been studied very well. An intermediate phase $ZrMo_2$ that melts with decomposition at 2153° has been established in the Zr-Mo system [11].

The solubility of Mo in β -Zr attains 20 at. % at $1773^\circ K$. Zirconium dissolves into Mo in the solid state within the limits of 3-5 at. %. Between the solid solution of Mo in β -Zr and $ZrMo_2$ there is a eutectic at 30 at. % Mo and $1790^\circ K$.

The Mo-C system has been investigated many times [12, 13], but until recently there was no single opinion about the composition and structure of molybdenum carbides that exist at high temperatures. Work [12] deciphered a complex structure of high-temperature molybdenum carbide and proposed the existence of two forms: hexagonal (of the $D6h^4$ type, $a_0 = 3.01 \text{ \AA}$, $c_0 = 14.61 \text{ \AA}$) and face-centered cubic ($a_0 = 4.28 \text{ \AA}$).

*The results of this work were reported in April 1963 at Kiev at the All-Union Seminar on the methods of producing refractory compounds, their electron structure and properties.

It was recently shown [14] that the cubic structure is a high-temperature modification of the hexagonal structure and its composition lies within the region from 40.0 to 40.8 at. % C.

For the Zr-C system the discrepancies are basically reduced to a statement of a different width of the homogeneity region of the ZrC_x -phase, and a different type of phase diagram, peritectic [15] and eutectic [16], which was the reason for an investigation of the phase diagram of Zr-ZrC [17], the results of which are used in this work.

The ZrC-MoC [18] and ZrC-Mo₂C [19] sections in the ternary system were studied previously.

These investigations did not clarify the flow of the processes of dissolution of the interacting phases; the solubility boundaries of the carbides were approximately determined as 1873 and 2373°K.

Only in work [20], in a detailed study of the structures of alloys of the Zr-C-Mo system at 1773 and 2373°K, were the causes of previous failures discovered; according to works [14, 20], the high-temperature cubic carbide Mo₃C₂, which was not fixed in works [18, 19], forms and with ZrC it gives a wide horn-shaped region of solid solutions. In particular, the data of work [20] confirm the quasi-binary nature of the ZrC-Mo section and the solubility of Mo in ZrC that we determined at 2373°K.

By the methods of chemical, x-ray and metallographic analyses for determining the temperature of the start of melting we investigated the ZrC-Mo section to clarify the possibilities of using alloys based on ZrC bound by Mo as refractory materials.

The initial material was ZrC containing about 0.2% N, 11.3 wt. % bonded and 0.5% free C (the free C was necessary to overcome the decrease in the amount of bonded C due to its partial depletion during sintering), and Mo with more than 99.6% of the basic element and W, Ta, Fe and other impurities.

For the charges we selected fractions of powders <60 μ; after carefully mixing and plasticizing these powders with a solution of polyvinyl alcohol we extruded rods 2 mm in diameter and 40 mm long; after sintering these rods in a TVV-4 furnace at 2273°K and 2 hours of aging we used them to determine the melting temperatures. To determine the limit of Mo solubility in ZrC we pressed (at 4 T/cm²) 10 × 10 mm cylinders that had been subjected to multiple sintering at 2270-2370°K with the necessary intermediate grinding after 1-2 hours of aging to a particle size of <60 μ, which guaranteed the attainment of equilibrium after 4-6 hours at these temperatures. The alloy was considered to be at equilibrium if further aging did not lead to a change in the grid constant of the solid solution, which was determined after each annealing. The dead-burned samples were again ground; part of the powder went for x-ray analysis and the remainder was analyzed for C_{total}, C_{bonded}, Zr and Mo (randomly).

| No. of the alloy | Composition | Calculated data | | | | Results of the chemical analysis | | | Regime of thermal treatment at 2273°K (hours until equilibrium) | Number of phases | Melting temperature (°K) |
|------------------|---|-----------------|-------|-------|-------|----------------------------------|-------|--------|---|------------------|--------------------------|
| | | Mo | | C | | Mo | C (%) | C free | | | |
| | | wt. % | at. % | wt. % | at. % | | | | | | |
| 1 | Zr _{0.988} Mo _{0.012} Co _{0.988} | 1 | 0.54 | 11.52 | 49.73 | — | 11.35 | 0.2 | 1 | 3740 ± 30 | |
| 2 | Zr _{0.946} Mo _{0.054} Co _{0.946} | 5 | 2.75 | 11.07 | 48.6 | 4.84 | 11.00 | 0 | 2 | 3580 ± 45 | |
| 3 | Zr _{0.890} Mo _{0.110} Co _{0.890} | 10 | 5.70 | 10.48 | 47.15 | 10.13 | 10.20 | 0 | 2 | 3350 ± 30 | |
| 4 | Zr _{0.837} Mo _{0.163} Co _{0.837} | 15 | 8.70 | 9.88 | 45.80 | — | — | — | 2 | 2850 ± 40 | |
| 5 | Zr _{0.788} Mo _{0.212} Co _{0.788} | 20 | 11.90 | 9.31 | 44.65 | 19.71 | 9.22 | 0 | 2 | 2570 — 2700 | |
| 6 | Zr _{0.725} Mo _{0.275} Co _{0.725} | 25 | 16.0 | 8.71 | 42.00 | — | — | — | 2 | 2570 | |
| 7 | Zr _{0.68} Mo _{0.32} Co _{0.68} | 30 | 19.80 | 8.12 | 40.45 | — | — | — | 2 | 2550 ± 30 | |
| 8 | Zr _{0.588} Mo _{0.412} Co _{0.588} | 40 | 26.40 | 6.96 | 36.80 | — | 6.81 | — | 2 | 2530 ± 25 | |
| 9 | Zr _{0.481} Mo _{0.519} Co _{0.481} | 50 | 35.10 | 5.80 | 32.45 | 50.15 | 5.74 | — | 2 | 2520 ± 15 | |
| 10 | Zr _{0.385} Mo _{0.615} Co _{0.385} | 60 | 44.40 | 4.64 | 27.80 | — | 4.53 | — | 2 | 2530 ± 15 | |
| 11 | Zr _{0.285} Mo _{0.715} Co _{0.285} | 70 | 55.6 | 3.48 | 22.20 | — | 3.35 | — | 2 | 2520 ± 10 | |
| 12 | Zr _{0.189} Mo _{0.811} Co _{0.189} | 80 | 68.2 | 2.32 | 15.90 | — | 2.20 | — | 2 | 2520 ± 10 | |
| 13 | Zr _{0.094} Mo _{0.906} Co _{0.094} | 90 | 82.0 | 1.16 | 8.55 | — | 1.06 | — | 2 | 2530 ± 20 | |
| 14 | Zr _{0.012} Mo _{0.988} Co _{0.012} | 95 | 92.0 | 1.10 | 4.90 | — | 1.00 | — | 2 | 2530 ± 20 | |
| I | Zr _{0.571} Mo _{0.429} Co _{0.571} | — | 53 | 4.48 | 27 | — | 4.56 | — | 3 | — | |
| II | Zr _{0.187} Mo _{0.813} Co _{0.187} | — | 65 | 3.06 | 20 | — | 3.00 | — | 3 | — | |
| III | Zr _{0.09} Mo _{0.91} Co _{0.09} | — | 80 | 1.69 | 12 | — | 1.76 | — | 3 | — | |

The table gives the investigated alloys and the results of the chemical analysis, and the number of phases revealed in the alloy by x-ray and metallographic analyses.

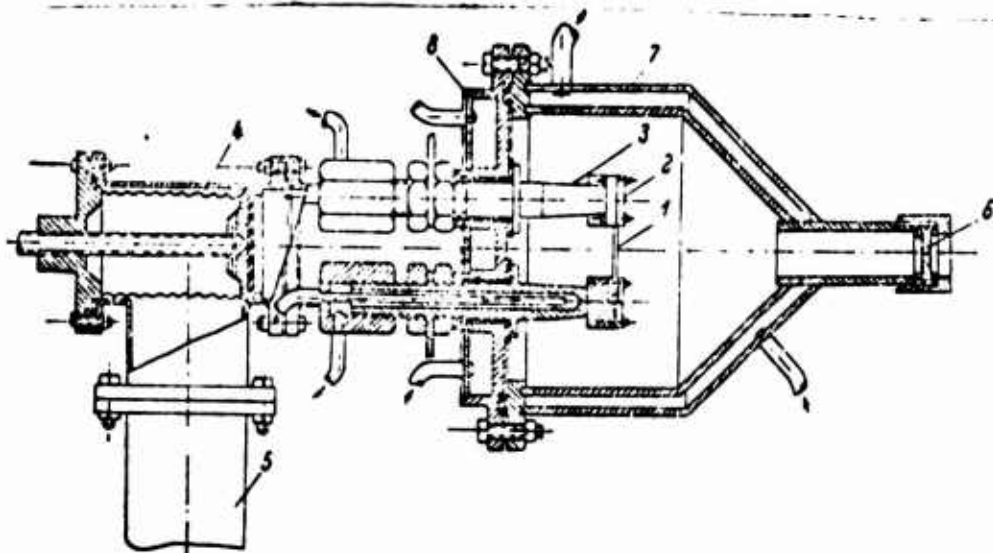

Fig. 1. Stand for determining the melting temperatures and for thermal treatment. 1) Sample; 2) contact plate (graphite, molybdenum); 3) water-cooled conductor; 4) siphon of the vacuum lock; 5) diffusion pump; 6) observation window; 7) water-cooled cover; 8) water-cooled stand.

The melting temperature was determined by the Pirani-Altcrthum method [21] in holes that imitated an absolute black-body and that were prepared with the aid of a spark glass in the above mentioned rods; heating was accomplished by direct passage of a current in the stand shown on Fig. 1. Samples can be heated in both an inert-gas

medium (He, A) and a vacuum of 10^{-4} mm Hg.

Most of the experiments in this work were conducted in a medium of pure argon. The temperature was measured with the aid of a OMP-0.9A optical micropyrometer with a correction for light absorption in the observation window, which was experimentally determined within the limits of 1500-3500°K.

The beginning of melting was reliably fixed by this method for alloys in the two-phase region close to the eutectic (and also the pure components), i.e., when the quantity of liquid necessary for visual fixation appeared in the hole, which changed the emission conditions. In the two-phase region that was enriched with the solid phase and in the regions of the solid solutions the observed temperatures for the start of melting were regularly higher than the actual temperatures, i.e., the alloys were "overheated" and we recorded the temperature in the liquid $+(Zr, Mo)C_x$ region with a phase ratio of $\frac{m_l}{m_s} = 1$. The amount of overheating is determined by the form of the solidus curve and by the value of the surface energy of the phases of the investigated system. When there is insignificant overheating the formed liquid maintains the framework of the solid-phase grains, and insignificantly changing emission conditions are usually very hard to record if a special photomultiplier is not used for this [22]. To correct the recorded temperatures for the start of melting in alloys

that lack the liquid, we used indirect methods, metallographic and x-ray analyses (we determined the composition of the solid phase from the lattice and its known dependence upon the composition of a solid solution). One of the methods of determining a temperature of the start of melting is prolonged holding at the solidus temperature until a "neck" forms around the opening due to shrinkage phenomena.

The beginning of melting was measured on 4-6 samples for each composition; the samples were kept at a temperature 80-100° below the specified for 15-20 min. After either thermal treatment the samples were quenched by switching off the electrical current and cooling in a flow of argon due to emission.

Besides the thermal treatment shown in the table, we conducted prolonged annealing at 2520° (2 hours) and 2373°K (3 hours). Alloys containing 1-20 wt. % Mo that were preliminarily annealed at 2520°K were subjected to additional annealing at 2373°K to establish the limit of Mo solubility in ZrC.

A change in the temperatures of the start of melting (see the table) as the Mo concentration in alloys increases is characteristic for a system with a eutectic transformation; the eutectic horizontal is located at 2520°K ± 15. Metallographic and x-ray analyses of the alloys also indicate the eutectic type of the ZrC-Mo phase diagram. Metallographic analysis established that the alloy $Zr_{0.189}Mo_{0.811}C_{0.189}$ (80 wt. % Mo) is close to the eutectic composition. The structures of hypoeutectic and hypereutectic melts are given on Fig. 2. According to the data of the x-ray and metallographic analyses the Mo solubility at the eutectic temperature attains 10 at. % (15-16 wt. %). After annealing for 2 hours at 2520°K alloys Nos. 1-4 are single phase, and an insignificant amount of excess Mo in the alloy $Zr_{0.788}Mo_{0.212}C_{0.788}$ (20 wt. % Mo) is distributed along the grain boundaries of the solid solution (Fig. 2, c); additional annealing at 2373°K (3 hours) leads to dissociation of the solid solution, separation of Mo throughout the grain and its partial coagulation (Fig. 2, d).

The x-ray analysis of the alloys annealed at 2520°K was conducted with copper radiation in VRS-3 chambers with reverse laying of the film; on the roentgenograms of the alloys containing 1.5, 10 and 15 wt. % Mo there are only differentiation maxima of the face-centered cubic phase, solid Mo in ZrC. As the Mo dissolves the grid shrinks, which leads to a decrease in a from 4.673 kX for the initial ZrC to 4.613 kX for the alloy with 11.9 at. % Mo (Fig. 3). Based on the known dependence $a = f(C_{Mo})$ and the lattice-parameter data of alloys annealed at 2273 and 2373°K, we established that the solubility of Mo in ZrC at these temperatures is 1.2 and 3.1 at. % respectively.

GRAPHIC NOT REPRODUCIBLE

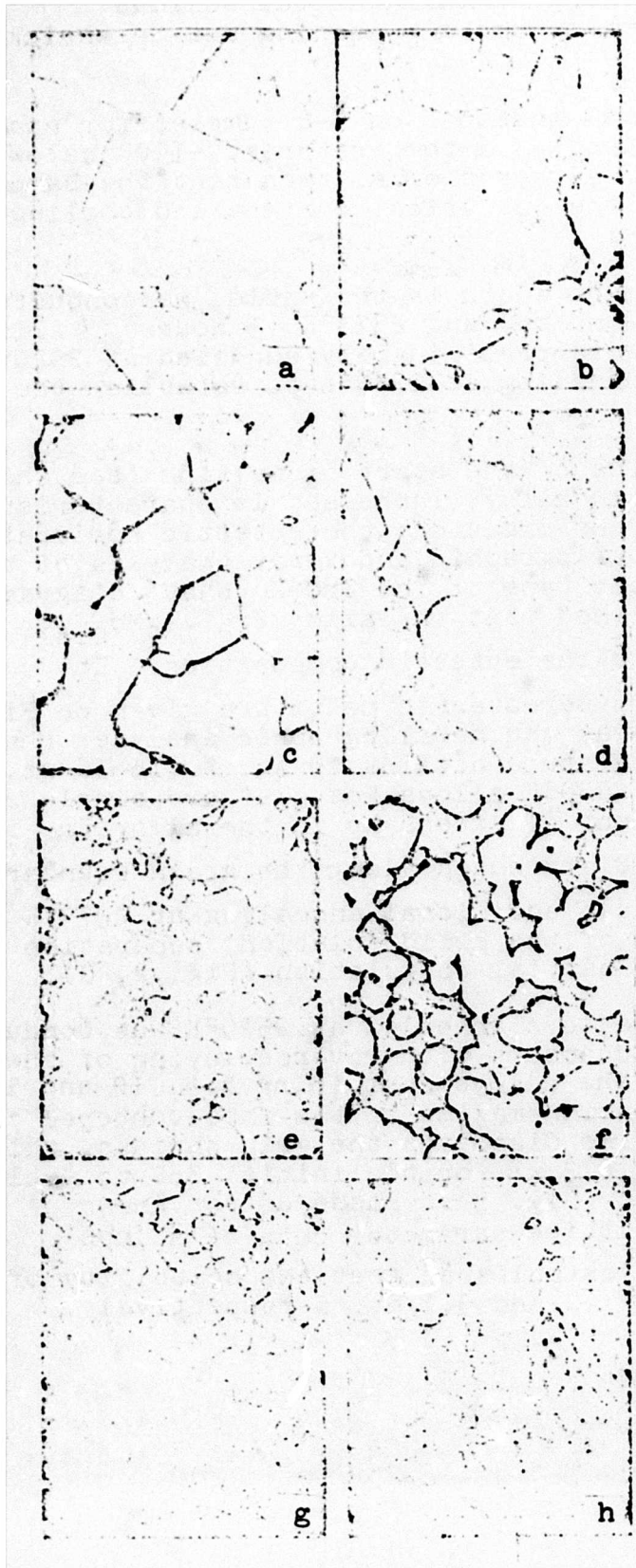

Fig. 2. Structures of the alloy and the system, $\times 800$. a) ZrC + 1 wt. % Mo, 3740°K for 0.5 min, solid solution; b) ZrC + 10 wt. % Mo, 3200°K for 5 min, solid solution; c) ZrC + 20 wt. % Mo, 2520°K for 40 min, solid solution + Mo along the grain boundaries; d) ZrC + 20 wt. % Mo, 2520°K , annealed at 2373°K for 3 hours, solid solution + Mo separated during dissociation of the solid solution; e) ZrC + 40 wt. % Mo, 2520°K for 30 min, solid solution + Mo; f) ZrC + 50 wt. % Mo, 2520°K for 3 min, solid solution + eutectic; g) ZrC + 70 wt. % Mo, 2520°K for 1 min, solid solution + eutectic; h) ZrC + 90 wt. % Mo, 2520°K for 1 min, Mo + eutectic.

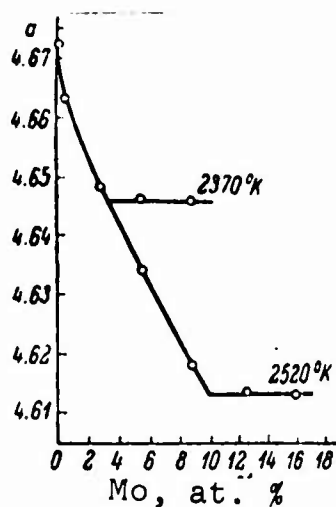

Fig. 3. Dependence of the grid constant a (kX) upon the Mo concentration (at. %) in a solid solution based on ZrC.

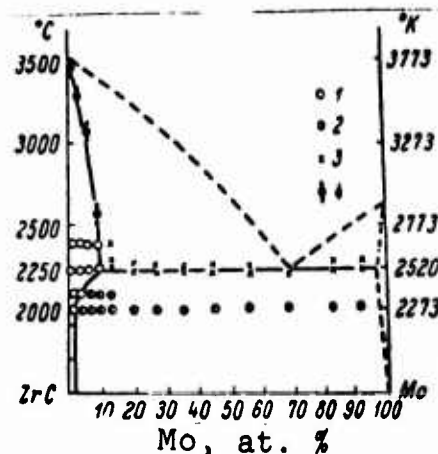

Fig. 4. ZrC-Mo phase diagram. 1) one phase; 2) two phases; 3) the start of melting of two-phase alloys; 4) the start of melting of one-phase alloys.

As the melting temperature of the carbide phase increases the temperature of the eutectic transformation increases, but the mutual solubility of the components is significantly reduced in comparison with that in the TiC-Mo system due to the increase of the difference of the atomic radii: While r_{Mo} differs from r_{Ti} by 4.3%, the difference of r_{Mo} from r_{Zr} attains 14.3%. The geometric factor also affects the structure of the appropriate phase diagrams, Ti-Mo and Zr-Mo; the first forms unlimited solid solutions in the β -form, and the second forms the chemical compound $ZrMo_2$ and limited solid solutions [23].

The alloys containing more than 25 wt. % Mo (both sintered at 2273°K and brought up to fusion) revealed two phases on the ionization roentgenograms, solid solutions based on ZrC and Mo. The solubility of ZrC in Mo is insignificant, which is indicated by the small change in the grid constant of Mo determined in the alloy $Zr_{0.042}Mo_{0.958}C_{0.042}$ in comparison with pure Mo (3.143 kX and 3.141 kX respectively). The low solubility of C in Mo, about 0.2 at. % at 2273°K, also confirms this.

The microhardness of the solid solution based on ZrC is 2500 kg/mm², and of molybdenum, 300-320 kg/mm²; the fine-grained sections of the eutectic are characterized by a microhardness of 950-980 kg/mm².

An x-ray investigation of three alloys (I, II, III, see the table) additionally prepared with an insignificant excess of C in comparison with the alloys lying on the ZrC-Mo section, i.e., distributed above the ZrC-Mo section close to the three-phase field of $Zr_xMo_yC_z-(MoZr)_2C-Mo$, showed that the alloys are three-phase, and therefore the boundary separating the two-phase field $Zr_xMo_yC_z-Mo$ from the above three-phase field is in direct proximity to the radiant section ZrC-Mo. This position is supported by the data of work [20].

Based on these data for the quasibinary system ZrC-Mo we constructed a phase diagram of the eutectic type (Fig. 4) with a eutectic transformation at 2520°K \pm 15. In comparison with the phase diagram of the TiC-Mo system the differences of the system we investigated are regular.

Because of the closeness of r_{Hf} and r_{Zr} , the structure of the HfC-Mo phase diagram must be similar to the proposed structure of the ZrC-Mo system: It is natural to expect a eutectic character of the diagram in this system, as occurs in the quasibinary systems $Me^{VI}C-Me^{VI}-TiC-Mo$, $TiC-W$, $ZrC-Mo$, $ZrC-W$. We determined the temperature of the eutectic transformation in the HfC-Mo system* to be 2583°K, i.e., higher than for the $Me^{VI}C-Mo$ system. We should also expect that this tendency is preserved in the interaction of $Me^{IV}C$ with W: In the $TiC-W$ system the eutectic temperature is 2923°K [3], in the $ZrC-W$ system, 3070°K, and in the HfC-W system it must be maximal. Based on the data given above we can estimate the eutectic temperature in the HfC-W system. Since the nature of the chemical bond in isostructural carbides $Me^{IV}C$ is identical, we can use the acceptance criterion $1/Nn$ proposed by Samsonov [24] as the power factor to compare the properties of individual carbides and their chemical behavior in systems with the same component (Mo, W).

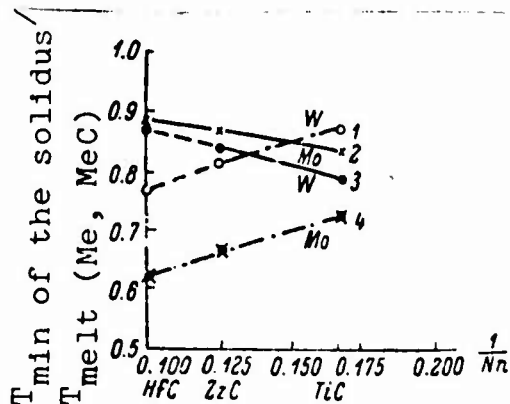

Fig. 5. The dependence of T_{min} of the solidus/ T_{melt} (Me, $Me^{IV}C$) upon the acceptance $1/Nn$ of the metal that forms the carbide. 1, 4)

T_{min} of the solidus/ T_{melt} (MeC); 2, 3)

T_{min} of the solidus/ T_{melt} (Me).

transformation of 3200°K. The fact that the ratio T_{min} of the solidus/ $T_{melt} Me^{IV}C$ in $Me^{IV}C-Mo(W)$ systems also decreases as the acceptance of the metal forming the carbide decreases indicates a decrease of the thermodynamic stability of these systems in the order $TiC-ZrC-HfC$.

*The phase diagram of the HfC-Mo system will be given in a separate report.

The dependence of the ratio of the eutectic temperature of one or another system to the melting temperature of Mo upon the acceptance of the metals of the corresponding carbides is expressed by a straight line (Fig. 5). If we assume that

in the case of the interaction of $Me^{IV}C-W$ the dependence of T_{min} of the solidus/ $T_{melt} Me$ upon $1/Nn$ also remains rectilinear

(Fig. 5), then the eutectic temperature in the HfC-W system can be estimated as 3200°K, the maximal for all the known carbide-metal systems. The ratio of the eutectic temperature to the melting

temperature of the carbide in $Me^{IV}C-Mo$ systems depending upon $1/Nn$ is expressed by a more complex dependence (Fig. 5). If we assume that the conditions of thermo-

dynamic stability are similar in $Me^{IV}C-Mo$

$Me^{IV}C-W$ systems, we can consider that the changes of the corresponding function in

$Me^{IV}C-W$ systems are similar, which also leads to a temperature of the eutectic

transformation of 3200°K. The fact that the ratio T_{min} of the solidus/ $T_{melt} Me^{IV}C$ in $Me^{IV}C-Mo(W)$ systems also decreases as the acceptance of

the metal forming the carbide decreases indicates a decrease of the thermodynamic stability of these systems in the order $TiC-ZrC-HfC$.

Conclusions

1. Based on the data of x-ray, metallographic and chemical investigations and measurements of the temperature of the start of melting in the Zr-C-Mo system we constructed a phase diagram of the quasibinary section ZrC-Mo.
2. We experimentally established that the solubility of Mo increases as the temperature increases; at 2273, 2373 and 2520°K it is 1.2, 3.1 and 9.9 at. %. The solubility of ZrC in Mo is insignificant.
3. The phase diagram of the quasibinary system ZrC-Mo was constructed according to the eutectic type; the eutectic horizontal occurs at 2520°K; the composition of the eutectic is close to the alloy $Zr_{0.189}Mo_{0.811}C_{0.189}$ (80 wt. % Mo).
4. Based on an analysis of the literary data and our own data we conclude that the $Me^{IV}C-Me^{VI}$ cross sections are quasibinary in the corresponding ternary systems and that the phase diagrams of these cross sections have a eutectic character.
5. With the aid of the acceptance criterion $1/Nn$ of the IV group metals, which form isostructural carbides, and data about the values of the eutectic temperatures in the TiC-Mo(W), ZrC-Mo(W) and HfC-Mo systems, we estimate the eutectic temperature in the HfC-W system to be 3200°K, i.e., maximal for carbide-metal systems.

Literature

1. Yeremenko, V. N., Z. I. Tolmacheva, and T. Ya. Velikanova. Issledovaniya po zharoprochnym splavam. (Studies of Refractory Alloys), Izd. AN SSSR, VIII, 95, 1962.
2. Yeremenko, V. N. and T. Ya. Velikanova. Poroshkovaya metallurgiya. (Powder Metallurgy), 5, 1963.
3. Nowotny, H., E. Parthe, et al. Z. Metallkunde, 45, 97, 1954.
4. Yeremenko, V. H. and L. A. Tret'yachenko. Tezisy dokladov seminarov po sposobam polucheniya i svoystvam karbidov tugoplavkikh metallov, yanvar' 1964 g. (Reports of the Seminar on Production Methods and Properties of Carbides of the Refractory Metals, January, 1964), Izd. AN SSSR, 1964.
5. McMullin, I. G. and I. T. Norton. J. Metals, 5, 1205, 1953.
6. Samsonov, G. V., L. V. Strashinskaya, and E. A. Shiller. IAN SSSR, OTN, Metallurgiya i toplivo, (Metallurgy and Fuel), 5, 167, 1962.
7. Rudy, E., F. Benesovsky, and El. Rudy. Monatsh. fur. Ch., 93, 693, 1962.

8. Ordan'yan, S. S., A. I. Avgustinik, and V. S. Vigdergauz. Tezisy dokladov nauchno-tekhnicheskoy konferentsii, aprel' 1964 g. (Reports of a Sci-Tech Conference, April, 1964), Izd. "Khimiya". M.-L., 1964.
9. Avgustinik, A. I. and S. S. Ordan'yan. Tezisy dokladov nauchno-tekhnicheskoy konferentsii, aprel' 1964 g. (Reports of a Sci-Tech Conference, April, 1964), Izd. "Khimiya". M.-L., 1964.
10. Bouman, M. sb. "Preobrazovaniye tepla i khimicheskoy energii v elektroenergiyu v raketnykh sistemakh", (In the Collection: "Conversion of Heat and Chemical Energy Into Electrical Energy in Rocket Systems"), IL, 128, 1963.
11. Domogala, F., D. I. McPherson, and M. Hansen. Trans. AIME, 197, 73-79, 1953.
12. Sykes, W. P., K. R. Van Horn, and C. M. Tucker. Trans. AIME, 117, 173-186, 1935.
13. Nowotny, H., E. Porthe, et al. Monatsh. für. Ch., 85, 255-272, 1954.
14. Rudy, E., F. Benesovsky, and K. Sedlatschek. Monatsh. für. Ch., 92, 84, 1961.
15. Samsonov, G. V. and N. S. Rozinova. Izv. AN SSSR, sektor fiz.-khim. analiza AN SSSR, (News of the USSR Academy of Science), 27, 126, 1956.
16. Benesovsky, F. and E. Rudy. Planseeberichte für Pulvermetallurgie, 8, 66-71, 1960.
17. Vil'k, Yu. N., S. S. Ordan'yan, et al. Tezisy seminara po sposobam polucheniya i fizicheskim svoystvam karbidov tugoplavkikh metallov, kremniya i bora, yanvar' 1964 g. (Reports of the Seminar on Production Methods and Physical Properties of Carbides of Refractory Metals, Silicon and Boron, January, 1964), Izd. AN USSR, 1964.
18. Umanskiy, Ya. S. Izv. AN SSSR, sektor fiz. khim. analiza instituta obshchey i neorganicheskoy khimii AN SSSR, (News of the USSR Academy of Science, Physicochemical Analysis of the Institute of Organic and Inorganic Chemistry), 16, 1, 127, 1943.
19. Nowotny, H. and R. Kiffer. Metallforschung, 2, 257, 1947.
20. Wallace, T. C., C. P. Gutierrez, and P. L. Stone. J. Phys. Ch., 67, 4, 1963.
21. Pirani, E. and H. Alterthum. Z. Elektrochem., 29, 5, 1923.
22. Storms, E. K. and N. H. Krikorian. J. Phys. Ch., 64, 1471, 1960.
23. Khansen, M. and K. Anderko. Struktury dvoynykh splavov. (Structures of Binary Alloys), Metallurgizdat, 1962.

24. Samsonov, G. V. DAN SSSR, (Reports of the USSR Academy of Science), 93, 4, 689, 1953.