

AMRL-TR-68-40

AD 675180



ANALOG SIMULATION STUDIES IN ECHORANGING

JOHN L. STEWART

Santa Rita Technology, Inc.

JULY 1968

This document has been approved for public
release and sale; its distribution is unlimited.

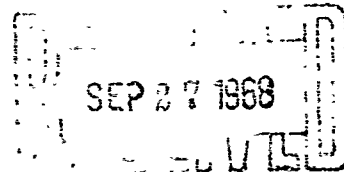

AEROSPACE MEDICAL RESEARCH LABORATORIES
AEROSPACE MEDICAL DIVISION
AIR FORCE SYSTEMS COMMAND
WRIGHT-PATTERSON AIR FORCE BASE, OHIO

NOTICES

When US Government drawings, specifications, or other data are used for any purpose other than a definitely related Government procurement operation, the Government thereby incurs no responsibility nor any obligation whatsoever, and the fact that the Government may have formulated, furnished, or in any way supplied the said drawings, specifications, or other data, is not to be regarded by implication or otherwise, as in any manner licensing the holder or any other person or corporation, or conveying any rights or permission to manufacture, use, or sell any patented invention that may in any way be related thereto.

Federal Government agencies and their contractors registered with Defense Documentation Center (DDC) should direct requests for copies of this report to:

DDC
Cameron Station
Alexandria, Virginia 22314

Non-DDC users may purchase copies of this report from:

Chief, Storage and Dissemination Section
Clearinghouse for Federal Scientific & Technical Information (CFSTI)
Sills Building
5285 Port Royal Road
Springfield, Virginia 22151

Organizations and individuals receiving reports via the Aerospace Medical Research Laboratories' automatic mailing lists should submit the addressograph plate stamp on the report envelope or refer to the code number when corresponding about change of address or cancellation.

Do not return this copy. Retain or destroy.

The experiments reported herein were conducted according to the "Guide for Laboratory Animal Facilities and Care," 1965 prepared by the Committee on the Guide for Laboratory Animal Resources, National Academy of Sciences—National Research Council; the regulations and standards prepared by the Department of Agriculture; and Public Law 89-544, "Laboratory Animal Welfare Act," August 24, 1967.

30C - August 1968 - CO455 - 47-1007

CFSTI	WHITE SECTION	DDC	WHITE SECTION
U.S. DEPARTMENT OF JUSTIFICATION			
BY	DISTRIBUTION AVAILABILITY CODE		
DIST.	AVAIL. and SPECIAL		

AMRL-TR-68-40

**ANALOG SIMULATION STUDIES
IN ECHORANGING**

JOHN L. STEWART

This document has been approved for public
release and sale; its distribution is unlimited.

FOREWORD

This study was initiated by the Biomedical Laboratory of the Aerospace Medical Research Laboratories, Aerospace Medical Division, Wright-Patterson Air Force Base, Ohio. The research was conducted by John L. Stewart, Santa Rita Technology, Inc., Menlo Park, California, acting as consultant to Sensory Systems Laboratory, 2700 West Broadway, Tucson, Arizona. Frederic A. Webster of that laboratory was principal investigator for contract AF33(615)-2964, and contract No. F33615-67-C-1879. The results of the earlier work are published as AMRL-TR-67-192. Colonel Jack E. Steele of the Mathematics and Analysis Branch, Biodynamics and Bionics Division, was the contract monitor for the Aerospace Medical Research Laboratories. The work was performed in support of Project 7233 "Biological Information Handling Systems and their Functional Analogs," and Task 723301, "Biological Mechanisms for Signal Analysis." The Analog Simulation studies were performed between April and August 1967.

This technical report has been reviewed and is approved.

WAYNE H. McCANDLESS
Technical Director
Biomedical Laboratory
Aerospace Medical Research Laboratories

ABSTRACT

An electronic analog of a bat cochlea (18 sections) and electronic circuits for generation of bat-like ultrasonic pulses is described. Ways in which such a system, bat or analog, could extract information about the range and nature of reflecting targets are discussed. Human experiments in which the nonlinearity mechanism of the bat cochlea could be bypassed to provide human listeners with signals similar to those which the bat's higher nervous system must analyze are suggested. It suggests jamming experiments to be tried on bats, which if successful would support the theory of the bats analysis technique.

TABLE OF CONTENTS

Section		Page
I	INTRODUCTION	1
II	BAT EAR CIRCUITS	1
	Scale Factor Adjustments	4
III	A THEORY FOR MONAURAL RANGING AND TARGET IDENTIFICATION	8
IV	SIMULATION EXPERIMENTS	12
	Human Experiments	15
V	JAMMING THE BAT	19

LIST OF ILLUSTRATIONS

Figure		Page
1	Passive Analog Ear Showing One of 18 Complete Circuits	1
2	Pre-Amplifier and Amplifier	5
3	Section Amplifier, Detector, and Filter	6
4	Analog Ear Power Supply System	7
5	Example Patterns for Primary and Echo Pulses	9
6(a)	Ultrasonic Chirper Modulator	13
6(b)	Timing Waveform Generator	14
7	Waveform for Synthesizer	16
8	Modulated Ultrasonic Chirps at 2 and 5 KHz	17
9	Cochleograms of Chirps	18

Section I

INTRODUCTION

The analog simulation for the ear of the bat constructed in 1965 by Santa Rita Technology, Inc, has been extensively rebuilt and retuned in order to better conform with current notions of cochlear action, especially as related to nonlinear processes. The theory of (monaural) echoranging and target identification depends in part on these nonlinearities, which were not sufficiently marked in their effects prior to the reconstruction.

The first part of this section of the report describes analog ear circuits in detail, and subsequently a theory will be set forth. Thereafter pattern examples made with the analog ear and high speed electronic commutator will be presented.

The last part of this report will suggest experiments of two kinds intended to better our understanding of the bat and help to verify or modify the various theories discussed herein. One type of experiment uses human observers with synthesized bat-like primary-echo signal combinations (albeit, with frequency and time scaling and not involving actual echoranging). The extent to which a human can make quality judgments and effect pitch tracking becomes of interest, assuming that the bat and the human have similar central system analyzing capabilities. The second set of proposed experiments attempts to disorient and otherwise jam bats in the process of food gathering.

Section II

BAT EAR CIRCUITS

A first estimate of the nature of the bat's ear is that of the human ear (Santa Rita Technology Analog Ear Model 2406P) except for a general upward scaling in frequency by a factor of four. Specifically, localization is changed from the range 50-20,000 Hz to the range 200-80,000 Hz.

Several other differences of more or less minor nature exist between human and bat analogs. Because the bat analog ear has 18 sections rather than 24, the ratio of series to shunt inductance values in the analog cochlea must be increased (as compared with Model 2406P). Also in the case of the bat the

outer-middle ear circuitry is simplified in its structure, consisting of only a single series capacitor and a single series inductor. The original bat ear analog provided functional representation of the middle ear in the driver amplifier--the rebuilt version uses flat amplifiers with direct circuit representation at the input to the cochlea. The point of excitation of the bat cochlea is not at the basal end as in the human analog (Section No. 1) but rather is located at section number five (out of 18 total). The first five sections of analog, namely those responsive mostly above the normal human auditory range, are equipped with diode nonlinearities of moderate strength so as to represent tissue motions that are less resisted in one direction than in the other.

The human analog acquires velocity response as voltage across the resistor in a series-resonant circuit. There is reason to accept such a representation for frequencies below a few kilohertz, but at higher frequencies it is not really possible to state whether it is velocity, displacement, or some combination of variables that represents subsequent neural activity. For the bat ear, the response variable is taken as the voltage across the capacitance in the series resonant circuit, except that the Q of the circuit is reduced to a relatively low value (2.2) with resistance in parallel with the capacitor. The result is a variable that adequately approximates basilar membrane velocity (except at very low frequencies where response of the relevant circuit is virtually negligible in any event).

Scale factors for response variables are set with potentiometers in parallel with section capacitors. These are adjusted with the complete ear operating so as to achieve appropriate localization patterns along with a plausible threshold characteristic. Note in this regard that reduced threshold for ultrasonic frequencies does not correspondingly reduce the strength of nonlinear components that may be generated in the basal five sections.

Figure 1 and Table 1 suffice to fully describe electrical parameters of the passive analog ear. Inductors use Ferrite pot cores (22 mm x 13 mm, $A_L = 400$, Ferroxcube, Inc. 3B9) with trimmer adjustments. All values were set on a bridge to better than 1% at 1 KHz. The relatively low impedance level of the analog ear insures that natural resonant frequencies of coils will be well above the highest frequencies likely to be applied.

The pre-amplifier and driver amplifier for the ear raise low level signals to about 50 volts peak-to-peak so that good nonlinear action can take place in the cochlea. The original

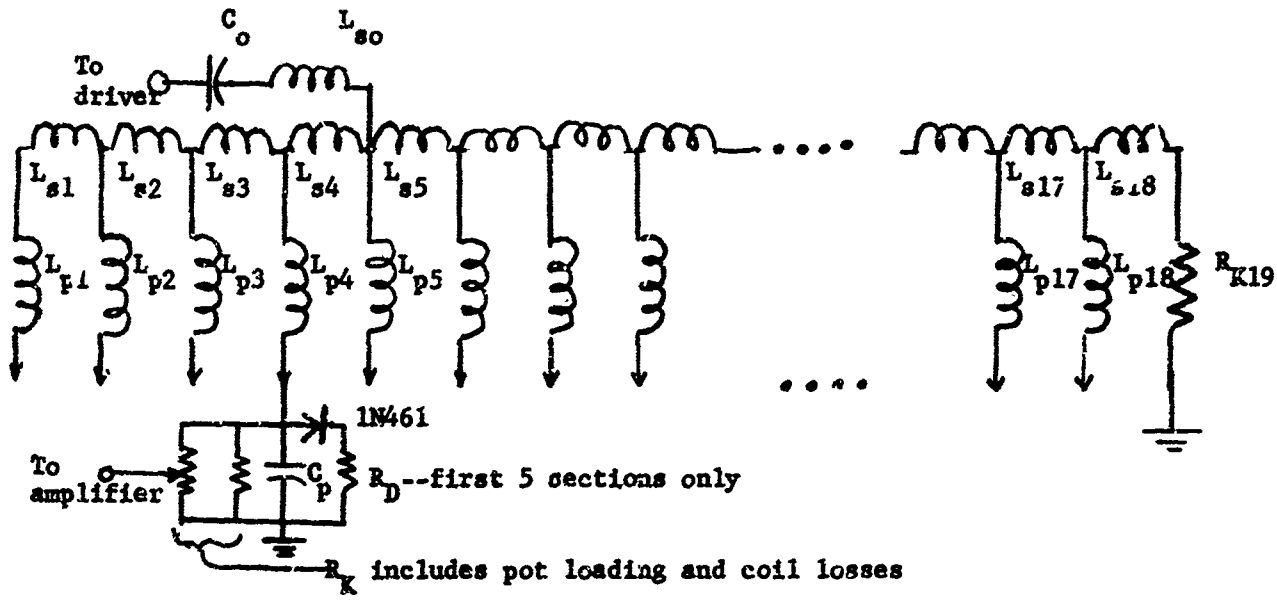

Figure 1 Passive Analog Ear Showing One of 18 Complete Circuits

Index	L_s mhy	L_p mhy	f_o Hz	$\omega_o L$	C_p	Gain pot	R_k for $Q=2.2$	R_D
0	10				.068 μ f			
1	3.33	10	80,000	5024	397 pf	100K	12000	12000
2	4.1	12.3	56,500	4366	645 "	"	10000	10000
3	4.9	14.7	39,000	3602	.00113 μ f	"	7800	8200
4	5.67	17	27,700	2959	.00194 "	"	6800	6800
5	6.47	19.4	19,300	2353	.00351 "	"	5600	5600
6	7.27	21.7	13,700	1868	.00623 "	"	3200	∞
7	8.03	24.1	9500	1439	.01164 "	"	3000	∞
8	8.8	26.4	6650	1103	.0217 "	"	2200	∞
9	9.6	28.8	4650	841	.0407 "	"	1520	∞
10	10.4	31.2	3280	643	.0755 "	"	1300	∞
11	11.2	33.6	2300	485	.143 "	"	1000	∞
12	11.97	35.9	1620	365.4	.2685 "	50K	820	∞
13	12.7	38.2	1140	273.6	.51 "	"	560	∞
14	13.5	40.6	800	204.1	.975 "	"	470	∞
15	14.3	43.0	560	151.3	1.88 "	"	330	∞
16	15.1	45.3	395	112.4	3.59 "	25K	220	∞
17	15.9	47.7	280	83.9	6.79 "	"	180	∞
18	16.67	50	200	62.8	12.68 "	"	120	∞
19							100	∞

Table 1 Bat Ear Parameter Values

amplifier yielded only a fraction of this signal and so a booster amplifier with separate power supply has been added. (A simple unified amplifier would of course be used in any repeated design--expediency was important in the present case.) The circuit of the pre-amplifier and driver is shown in Figure 2.

Each of the 18 response signals from the analog cochlea is amplified, detected, and filtered prior to submission to the commutator for analysis. The circuit diagram of one of the amplifiers is shown in Figure 3.

The dual power supply for all amplifiers is shown in Figure 4.

Scale Factor Adjustments

The setting of the scale factor potentiometers is done so as to yield the correct localization pattern for sine wave excitation while also providing a reasonable threshold characteristic. To obtain the desired localization curve, apply an input sine wave at, say, 1000 Hz. Adjust gains so that, on the high frequency side of the pattern, the amplitude drops by 4.1 db (voltage ratio of 1.6 or $1/1.6 = 0.625$) per section towards the basal (high frequency) end. This adjustment, if carried over the entire cochlea, gives a total difference in gain values of 74 db from the narrowest band low pass filter response point to the widest. The 74 db figure also applies to the human analog.*

In carrying out this adjustment procedure, gain values at cochlea points below about 1000 Hz can be adjusted more or less to give a smooth transition--actual values are not so meaningful as getting a smooth pattern. If the scale factor potentiometers are near their maximum settings in the 1000 Hz region, overall pattern magnitude will be usefully large. It is pointed out that adequate signal levels must be applied to section detectors in order that the germanium diodes respond properly.

It may be difficult using a 1000 Hz sine wave to obtain proper adjustments in high frequency regions of the cochlea due to excessively small magnitudes. After setting as many potentiometers as possible with 1000 Hz, the process can be continued by using a higher frequency, but one which localizes in the region previously adjusted with the 1000 Hz signal.

*Stewart, John L., "Speech Processing with a Cochlear-Neural Analog." AMRL-TR-66-229, Aerospace Medical Research Laboratories, Wright-Patterson Air Force Base, Ohio, February 1967. In particular, Appendix 1, pp. 82-83.

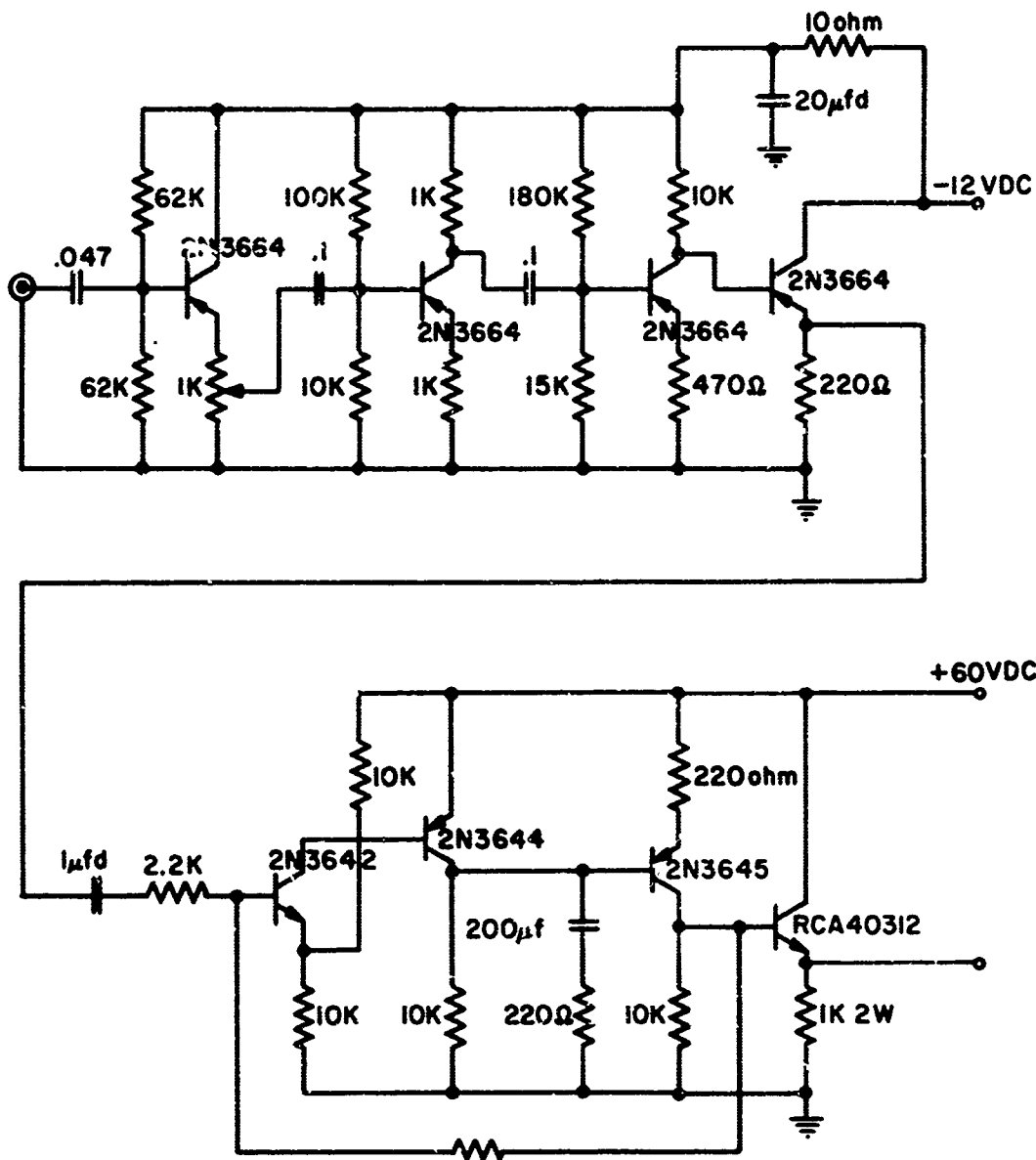

Figure 2 Pre-Amplifier and Amplifier

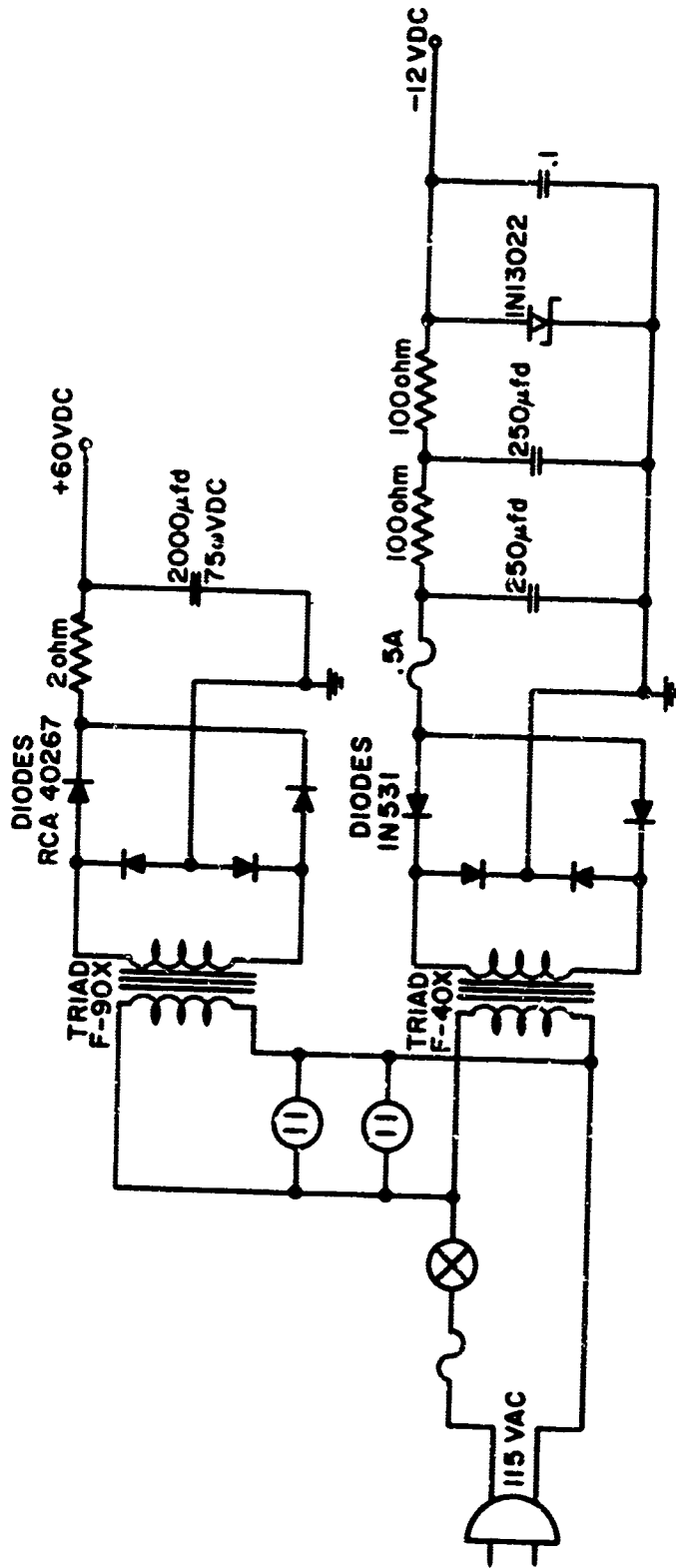

Figure 4 Analog Ear Power Supply System

Section III

A THEORY FOR MONAURAL RANGING AND TARGET IDENTIFICATION

The primary emission consists of a series of ultrasonic chirps from less than one to several milliseconds in duration. The ultrasonic carrier glides smoothly downward in frequency during each chirp over a 2:1 range. The repetition rate is of the order of 10 or 15 per second until a target has been acquired when it increases more or less regularly as the target is approached to a maximum of perhaps 200 per second, remaining constant until capture of the target. The envelope of each chirp is fairly regular and rounded. As the repetition rate increases, the pulse width may decrease to a minimum of about one-half millisecond. The downward limits to the glide in ultrasonic carrier frequency may not be greatly changed as pulse width decreases (except, of course, the glide will occur more rapidly).

The primary emission will obviously be received at the ear. The basal part of the cochlea will respond along with primary neurons in this region. A direct echo, if strong enough, will be received a short time after the start of the primary emission. Time delays from primary to echo extend from several milliseconds (roughly two msec. per foot in range) to less than one millisecond. The echo from one pulse will overlap the following primary emission if pulse duration is great enough.

The general assumption made in order to postulate the technique used by the bat is that it is the envelope of the received signal that contains needed information. A primary signal and typical nonoverlapping echo (for a small target) are shown in Figure 5a. A frequency analysis of the envelope of the primary will show components that are maximum at low frequencies with components diminishing with frequency. A similar analysis of the echo will show frequency components extending to higher frequencies. The complexity of the echo, i.e., how high in frequency important components are to be found, depends upon the structural irregularities of the target. The frequency gliding nature of the primary signal promotes production of interference patterns for other than very simple targets.

It appears that the bat may attempt to avoid extensive overlap of primary and echo signals until the terminal phase of his pursuit. Specifically, the pulse width decreases from 2 or 3 msec. at a range perhaps 1-2 feet to approximately 0.5 msec. when range to target is about one-half foot. Simultaneously, the repetition rate increases from perhaps 25 per second to approximately 200 per second.

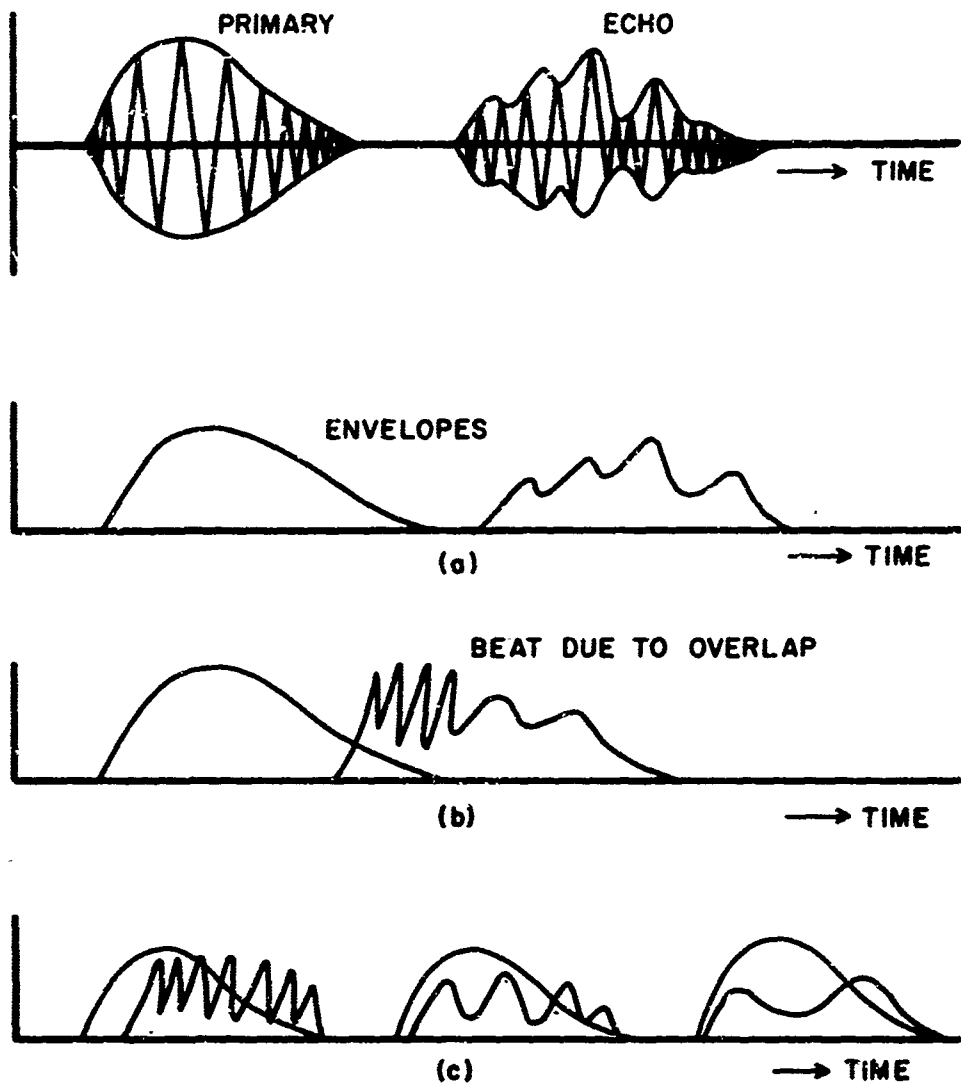

Figure 5 Example Patterns for Primary and Echo Pulses

It is thought that four phases of the bat's pursuit procedure exist insofar as demodulated waveform patterns are concerned. The first applies to the searching bat. In this case individual primary signals occur without echoes; the bat more or less ignores the situation.

The second phase occurs when a target reflection becomes large enough to be perceived. Delay time remains relatively large so that no overlap between the echo and the following primary can occur. During this second phase, some target analysis can take place according to the detail in the echo as suggested in Figure 4a.

The bat may have the opportunity to make some range determinations during Phase 2 as follows: The primary and the echo comprise a pulse pair with an equivalent pitch periodicity equal to the reciprocal of the time separation. Thus a pitch sensation equivalent to range can be identified. In experiments with humans, pairs of clicks can similarly be associated with a pitch periodicity quality. As a target is approached, the bat may first experience a weak low pitch sensation with the pitch of the sound gradually increasing while the intensity of the sound also becomes more intense.

During Phase 2, the bat hears a complex sound having timbre quality relating details of the echo and a fundamental pitch quality relating to time separation between primary and echo. He may thus make both quality and range judgments of the sound. As this complex sound becomes more intense, the bat may tend to track the increasing pitch by increasing his fundamental buzz rate in synchronism.

Phase 3 commences at a range of approximately one foot when the primary emissions begin to overlap the echoes. When this first occurs the envelope of the leading part of the echo bears a relatively high frequency fluctuation, equal in fact to the difference in primary (ultrasonic) frequencies between leading and trailing parts of the primary emission; this may be of the order of 20 KHz. If the duration of the primary pulse were to remain constant, this interference frequency would gradually diminish, pulse by pulse, towards zero as the target was approached. But the bat appears to forestall this by reducing his pulse width while not necessarily changing the beginning and ending frequencies of his ultrasonic chirps.

The vocalizing apparatus of the bat probably becomes more stressed and tightened as buzz frequency increases, thus also shortening the width of the pulse. The attempt to track pitch may thus automatically retard the development of an extensive

primary-echo temporal overlap, thereby permitting the nature of the target itself to determine timbre quality of the sound during Phase 3. Figure 5b attempts to denote what occurs as temporal overlap develops.

The fourth phase of pursuit is the terminal phase when the bat cannot further increase buzz rate or diminish pulse width. The beat frequency between primary and echo will decrease rapidly over the period of several pulses, from 20-40 KHz towards zero, in a time span of perhaps 50 msec. This rapid glide constitutes a very unique cue for the bat to make appropriate motions with his wings and other parts so as to capture the target. It is apparent that extraneous natural noises as, for example, from other bats, will have very little effect on this terminal phase glide. During the terminal phase not much target analysis can likely take place--if the bat has been fooled up to this point with a false target, he will not likely remedy his error. The nature of the echo during the terminal phase is suggested by the several sequential echoes in Figure 5c.

The theory presented here is a monaural one. It is sufficient to explain the bat's real capabilities except for lack of bearing information. The bat's pinna comprises a directive acoustic horn. With it operating as a lobing device, the bat can determine bearing as well as range. One such horn may be enough to permit moderately good performance. With two horns in a binaural arrangement, performance can of course be much better because the necessity for lobing from pulse to pulse using one horn can be replaced with a monopulse binaural system permitting some bearing data to be acquired from a single echo.

The mammalian ear is thought to be neurally innervated with a system having mutual inhibition in which activity of one group of fibers inhibits that of neighboring groups. The latency of this inhibition is of the order of 10 msec. Inhibition serves to sharpen patterns in space and in time while helping to adapt the ear's neural system to ambient noise and signal levels. But the effectiveness of inhibition is small for signals which are appreciably shorter than 10 msec. Neural patterns from primaries and echoes in the bat's ear are probably not greatly affected by mutual inhibition, although the process will be helpful in adapting to the general noise level.

In the mammalian ear, efferent control having a time constant of the order of 50-100 msec. may be of major importance to adaptation. The bat can perhaps adapt at this level to his primary emission and also perhaps during an actual pursuit, since a complete pursuit takes about 200 msec. or more. It is not known if efferent fibers have been found in the bat's cochlea; but since

even simpler animals such as the grasshopper are thought to possess them, along with most mammals, their presence in the bat is at least plausible.

The cochlea localizes frequency components. A first order nonlinear cochlear process demodulates envelopes of ultrasonic signals in the acoustic range, the most important components lying below the ultrasonic range of the primary emission. These demodulated signals produce time-space cochlear patterns having a gross temporal characteristic comparable to time periods associated with pulse durations and primary-to-echo separations. That is, a group of cells along the cochlea will activate in pulses of one-half to 3 msec. duration with considerably less than one msec. to perhaps 50 msec. pulse-to-pulse separation. It is the task of the ascending (central) neural system to analyze the signal into these relatively low frequency components. Specifically, the value of equivalent pitch can be determined in association with place along the cochlea to provide range and quality evaluations, respectively, as previously discussed. Because of the speed with which these several evaluations must be carried out, inhibiting processes are probably not utilized except with respect to adaptation to the environment. Although the bat can effect meaningful target quality determinations, questionable presence of inhibitions will limit what the bat can do to less than that achievable by a human in listening to various sustained voiced sounds. In short, it may be a mistake to overestimate the capability of the bat's system in this regard.

Section IV

SIMULATION EXPERIMENTS

The bat ear analog with nonlinearities in place has been excited with simulated echo signals. Response of the ear has been displayed on an oscilloscope using a high speed electronic commutator. The patterns that arise have been photographed.

The synthetic source generates a downward sweeping ultrasonic signal which can simultaneously be modulated in amplitude. A uni-junction time base is used to frequency modulate a Wavetek Model 105 waveform generator. This time base also provides a rectangular on-off pulse signal which is added to a sine wave with the combination modulating the frequency swept signal to give the desired final result. Figure 6a shows the principal part of the system and Figure 6b shows the time base and sweep signal.

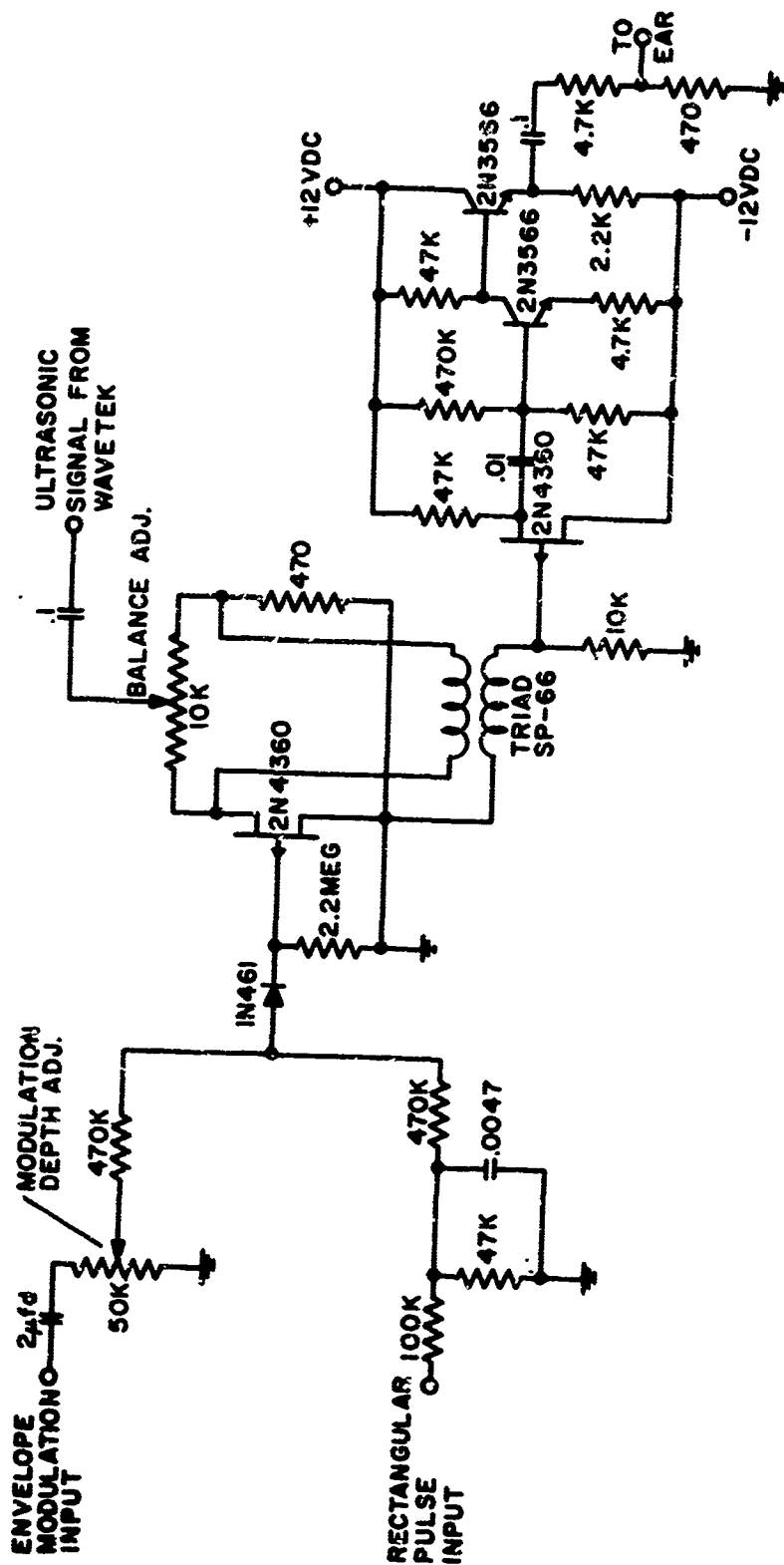

Figure 6(a) Ultrasonic Chirper Modulator

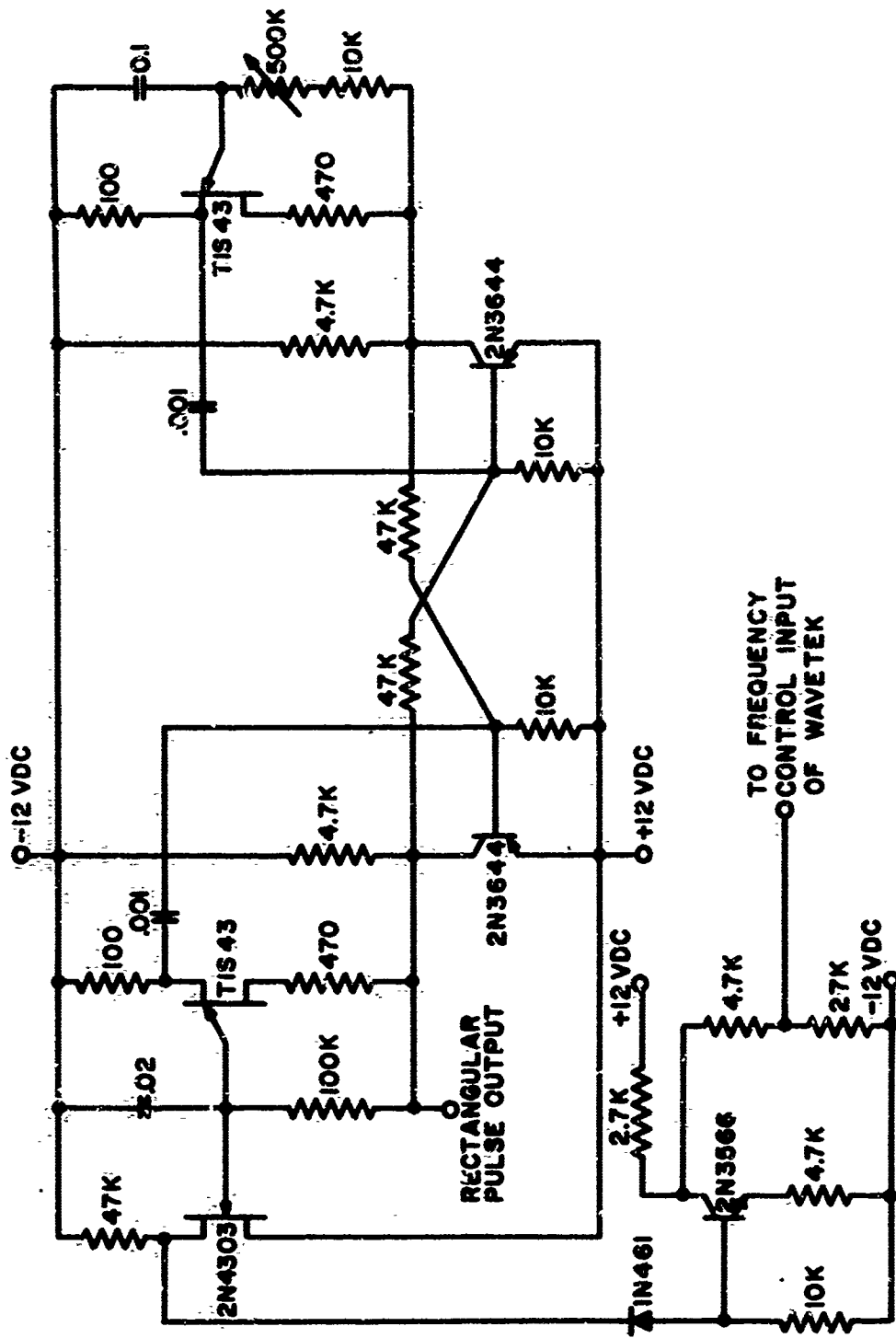

Figure 6(b) Timing Waveform Generator

Figure 7a is a photograph of pulses as produced with the synthesizer without sine wave modulation. Figure 7b shows the rising part of the pulse. Figure 8a is the pulse with a small degree of modulation and Figure 8b is for a larger and lower frequency one.

The pattern on the cochlea for the unmodulated pulse is shown in Figure 9a. The range of ultrasonic sweep in this (echoless) case is of little importance. The unduced pattern near the apex of the cochlea comprises, essentially, an analysis of the simple rectangular pulse envelope. Even with higher frequency modulation components, this basic rectangular envelope component response remains.

Patterns that result when the pulse is modulated with 2 and 4 KHz (at about 50%) are shown in Figures 9b and 9c, respectively. These shapes are relatively independent of primary (ultrasonic) frequency and repetition rate--only the detail in the envelope function is of importance. Analysis can obviously be effective.

Human Experiments

The hypothesis is made that neural system processing in bats is similar to that effected by other mammals. The effects of the nonlinear ultrasonic cochlear region in the bat may be considerably more pronounced than in other mammals, especially man. This means that equivalent human experiments must be designed to bypass the mechanical nonlinearity mechanism by producing synthetic echo-like signals which enter the ear at normal audio frequencies.

The first suggested experiment uses click pairs. Each pair can at the outset have, say, 5 msec. spacing between elements and pairs can occur at a rate of 20 per second. While listening to these clicks, the human is asked to "track" the sound with his own voice. While engaged in this tracking, the time between clicks in a pair is gradually reduced by separate means. The behavior of human voice pitch tracking, perhaps after some training, would be of specific interest. A modification of this experiment is to employ a submultiple of the human glottal pulse rate for triggering click pairs. In tracking pitch periodicity derived from click pair time separation, the human might then be induced to increase his buzz rate as clicks occur closer together. This is meant to simulate the bat during Phases 2 and 3 of his pursuit.

The second experiment uses click pairs (i.e., rectangular pulses of perhaps 5 msec. duration) wherein the second click has

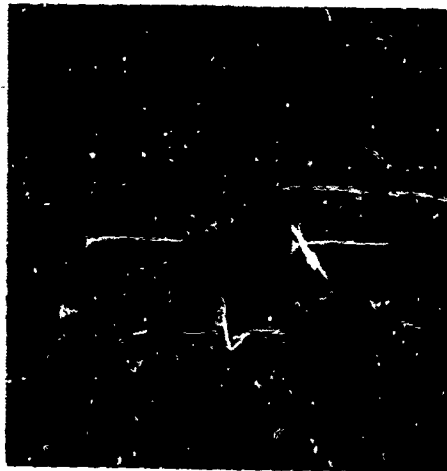

Time Scale: 1 ms/cm

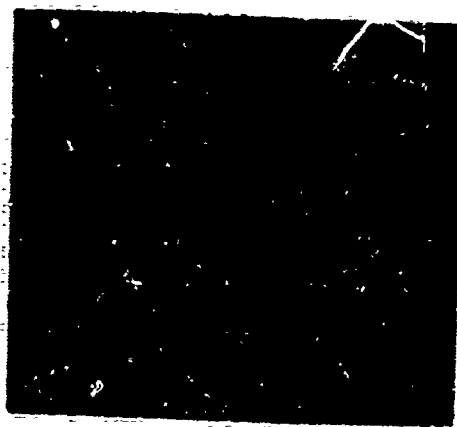

Time Scale: 20 μ s/cm

Figure 7 Waveform for Synthesizer. Top: Series of pulses. Bottom: Leading part of one pulse.

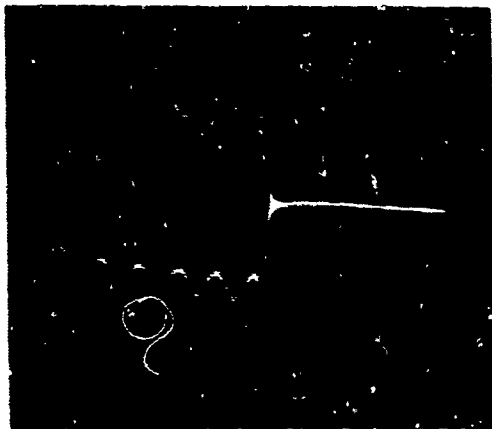
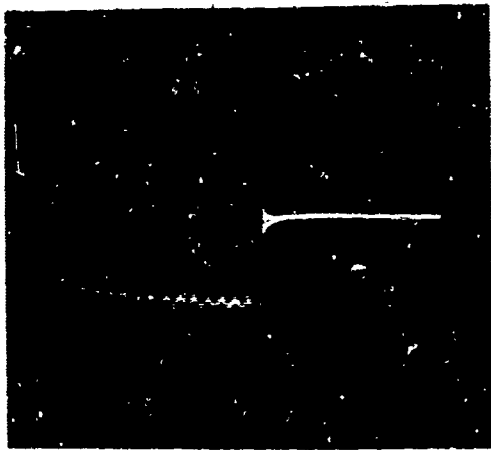
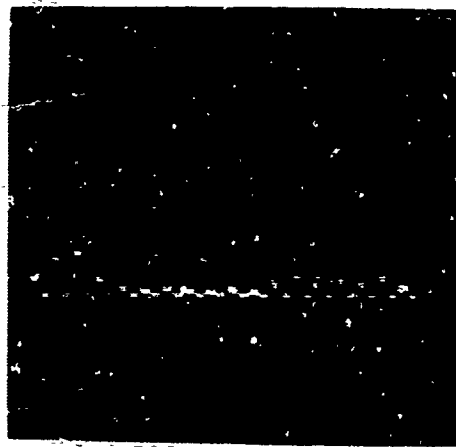
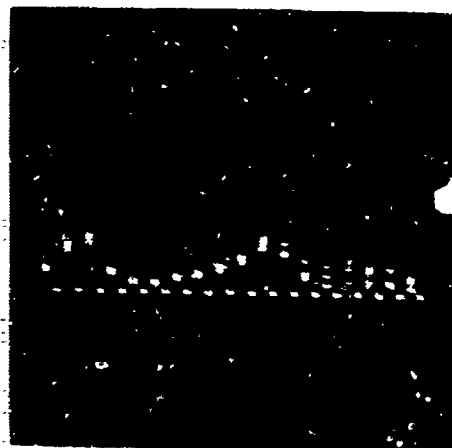

Figure 8 Modulated Ultrasonic Chirps at 2 and 5 KHz. Time scale: 500 μ /cm.



Distance →
 (a) No modulation



Distance →
 (b) 2000 Hz modulation,
 50%

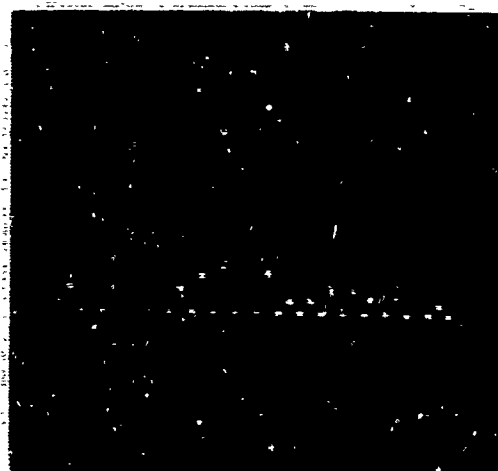

Distance →
 (c) 4000 Hz modulation,
 50%

Figure 3 Cochleograms of Chirps. Chirp rate uncritical (10-200/sec). Chirp duration approximately 2 msec. The pattern due to direct ultrasonic stimulation is at the far left. The ever-present component due to the unmodulated pulse is at the far right.

superimposed upon it various modulations, especially sine waves or bands of noise at various average frequencies. The intent here is to determine the extent to which envelope complexity can be used for identification.

In both of the foregoing experiments, the first click in a click pair should be made larger than the second click. The allowable intensity difference in fact becomes a matter of some importance--in the case of the bat the first pulse (emission) will be considerably larger than the echo, especially for long target ranges.

The foregoing human experiments are directed at understanding Phases 1 and 2 of the bat's pursuit procedure. The last two phases are more difficult to represent with human experiments because of limitations in the human vocalizing apparatus. In the case of Phase 3, it becomes necessary to cause the tracking human to decrease the duration of this glottal pulse, which is not readily achieved over a wide range. For Phase 4, it is necessary to introduce some form of rapidly gliding pulse-to-pulse envelope characteristic in order to provide a terminal pursuit situation.

The question naturally arises as to the feasibility for using the human in a more closely simulated bat-like situation involving real ultrasonic emissions and real echoes. The theory presented here certainly provides a point of departure for studying this situation. It also points out some of the problems that may arise because of limited human capabilities in vocalization along with relatively weak nonlinear demodulation phenomena in the human cochlea.

Section V

JAMMING THE BAT

During Phases 2 and 3, the bat tracks a varying pitch voice-like sound in a manner that can be understood in human terms as listening to and tracking a voiced vowel sound wherein vowel quality specifies the nature of the target and where voice fundamental pitch represents target range. Jamming the bat thus becomes similar to jamming the perceived vowel sound. It is well known that quite intense Gaussian noise is needed to produce vowel jamming. A better procedure would seem to be that of using voice-like jamming signals of the so-called cocktail party type.

The bat perceives envelope fluctuations in the normal acoustic range. Acoustic jamming signals should thus be in this range. In particular, it is suggested that 1-2 msec acoustic pulses be employed by gating a band of noise of a few KHz center frequency. The pulses should occur in pairs having about one msec. spacing with pairs occurring at a convenient rate not necessarily critical with respect to the bat's buzz rate. The highest pulse rate could be of the order of 500-2000 per second in which case pulse pairing gives way to a semiperiodic pulse sequence.

During Phase 3 of his pursuit, the bat may strive to avoid excessive primary-echo overlap, which requires adequately short pulses. When overlap develops, a high sonic envelope frequency fluctuation is introduced--perhaps of the order of 20 KHz. It may prove beneficial in jamming to radiate pulses containing frequency components in the 20 KHz range as well as at lower frequencies.

Phase 4 is characterized by a very rapid downward drift in envelope frequency from pulse to pulse. This phase could offer a singular opportunity to confuse the bat. To take advantage of peculiarities during the terminal pursuit phase, the jamming signal can be suitably tailored into narrow (one-half msec) pulses with pulses grouped into 50 msec intervals. For each such 50 msec group, pulse frequency should be diminished from about 20 KHz to a few KHz, with this cycle repeated each 50 msec. Pulse repetition rates of perhaps 1000 per second should be permissible and will maximize the rate at which false target indications are submitted to the bat.

Security Classification

DOCUMENT CONTROL DATA - R & D

(Security classification of title, body of abstract and indexing annotation must be entered when the overall report is classified)

1. ORIGINATING ACTIVITY (Corporate author) Santa Rita Technology, Inc. Menlo Park, California 94025		2a. REPORT SECURITY CLASSIFICATION UNCLASSIFIED	
		2b. GROUP N/A	
3. REPORT TITLE ANALOG SIMULATION STUDIES IN ECHORANGING			
4. DESCRIPTIVE NOTES (Type of report and inclusive dates) Final Report, April 1967 - August 1967			
5. AUTHOR(S) (First name, middle initial, last name) John I. Stewart			
6. REPORT DATE July 1967		7a. TOTAL NO. OF PAGES 20	7b. NO. OF REFS 0
8a. CONTRACT OR GRANT NO. F33615-67-C-1879		8b. ORIGINATOR'S REPORT NUMBER(S)	
8c. PROJECT NO. 7233			
8d. Task No. 723301		9b. OTHER REPORT NO(S) (Any other numbers that may be assigned this report) AMRL-TR-68-40	
10. DISTRIBUTION STATEMENT This document has been approved for public release and sale; its distribution is unlimited.			
11. SUPPLEMENTARY NOTES		12. SPONSORING MILITARY ACTIVITY Aerospace Medical Research Laboratories Aerospace Medical Div., Air Force Systems Command, Wright-Patterson AFB, OH 45433	
13. ABSTRACT An electronic analog of a bat cochlea (18 sections) and electronic circuits for generation of bat-like ultrasonic pulses is described. Ways in which such a system, bat or analog, could extract information about the range and nature of reflecting targets are discussed. Human experiments in which the nonlinearity mechanism of the bat cochlea could be bypassed to provide human listeners with signals similar to those which the bat's higher nervous system must analyze are suggested. It suggests jamming experiments to be tried on bats, which if successful would support the theory of the bats analysis technique.			

DD FORM 1473
1 NOV 65

Security Classification

Security Classification

14. KEY WORDS	LINK A		LINK B		LINK C	
	ROLE	WT	ROLE	WT	ROLE	WT
Bat						
Cochlea						
Echoranging						