

APPLIED MANUFACTURING RESEARCH AND PROCESS DEVELOPMENT  
DEPARTMENT 190

AD 677099

NUMERICAL CONTROL AND ITS APPLICATION  
TO MANUFACTURING

FINAL REPORT

RMDA SD-9-5

W.O. 8605

October 1960

NOV 8 1968

Distribution of this document  
is unlimited.

Prepared by:

S. C. Padilla

S. C. Padilla  
Mfg. Dev. Engineer

Approved by:

F. A. Monahan

F. A. Monahan, Chief  
Applied Mfg. Research  
and Process Development

Approved by:

A. P. Langlois

A. P. Langlois  
Supervisor

Corporate Report 14-23

CONVAIR  
ASTRONAUTICS  
OCT 21 1960  
LIBRARY

Reproduced by the  
CLEARINGHOUSE  
for Federal Scientific & Technical  
Information Springfield Va. 22151

CONVAIR  
A Division of General Dynamics Corporation  
( San Diego )

## TABLE OF CONTENTS

<u>PARA</u>		<u>PAGE</u>
1.0	PROJECT TITLE	1
2.0	STATEMENT OF PROBLEM	1
3.0	OBJECTIVE AND PURPOSE	1
4.0	CONCLUSIONS	1
4.1	The Electronic Control Systems (ECS/Morey) Machines	1
4.2	The McKay Numerically Controlled Drilling and Counterboring Machine	1
4.3	Automatic Inspection Devices	2
4.4	F-108 Wing Program	2
4.5	General Procedures for Numerically Controlled Machining of Models	2
5.0	RECOMMENDATIONS	2
6.0	IMPLEMENTATION	2
7.0	DEVELOPMENT OF THE PROJECT	3
7.1	The Electronic Control Systems (ECS/Morey) Machines	3
7.1.1	Background	3
7.1.2	Procedures followed and results	3
7.2	The McKay Numerically Controlled Drilling and Counterboring Machine	7
7.2.1	Background	7
7.2.2	Procedures followed and results	7
7.3	Automatic Inspection Devices	15
7.3.1	Background	15
7.3.2	Procedures followed and results	15
7.4	F-108 Wing Program	18
7.4.1	Analytical lofting	18
7.4.2	Master and production tooling	18

**TABLE OF CONTENTS**  
(continued)

<u>PARA</u>		<u>PAGE</u>
	7.4.3 Machining by numerically controlled methods	19
	7.4.4 Retrofit applications	19
	7.4.5 Inspection methods	20
7.5	General Procedures for Numerically Controlled Machining of Models	20
	7.5.1 Background	20
	7.5.2 Procedures followed and results	21
8.0	ACKNOWLEDGMENTS	23
9.0	BIBLIOGRAPHY	24
Appendix A	Data on the Electronic Control Systems - Morey Machines	25
Appendix B	Data on the McKay Numerically Controlled Drilling and Counterboring Machine	42
Appendix C	Proposal to Develop a Numerically Controlled Inspection Machine	45

**LIST OF ILLUSTRATIONS**

<u>FIGURE</u>	<u>TITLE</u>	<u>PAGE</u>
1.	Check Plate	5
2.	Machining a "Dural" Test Plate	6
3.	McKay Test Plates, Set III	8
4.	McKay Test Plates, Set III, Typical Pattern	9
5.	Copy of RMDA on Automatic Inspection Devices (Sheets 1 and 2)	16-17
A-1	Morey No. 1, Test Tape No. 1, Feed Rates, X-axis	28
A-2	Morey No. 1, Test Tape No. 1, Feed Rates, Y-axis	28
A-3	Morey No. 1, Test Tape No. 1, Feed Rates, Z-axis	29
A-4	Morey No. 2, Test Tape No. 1, Feed Rates, X-axis	29
A-5	Morey No. 2, Test Tape No. 1, Feed Rates, Y-axis	30

**LIST OF ILLUSTRATIONS**  
(continued)

<u>FIGURE</u>	<u>TITLE</u>	<u>PAGE</u>
A-6	Morey No. 2, Test Tape No. 1, Feed Rates, Z-axis	30
A-7	Morey No. 1, Test Tape No. 2, Positioning Test, X-axis	38
A-8	Morey No. 1, Test Tape No. 2, Positioning Test, Y-axis	39
A-9	Morey No. 2, Test Tape No. 2, Positioning Test, X-axis	40
A-10	Morey No. 2, Test Tape No. 2, Positioning Test, Y-axis	41
B-1	McKay Test Plates, Deviations, Set III	43
B-2	McKay Test Plates, Deviations, Set III	44
C. 1.	Proposed Schedule	51
C. 2.	A Potential Inspection Machine	55
C. 3.	Inspection Program	56
C. 4.	Read-out Display	58
C. 5.	Sample Questionnaire	61

**LIST OF TABLES**

<u>TABLE</u>	<u>TITLE</u>	<u>PAGE</u>
I	McKay Drill and Counterbore Acceptance Test Program	10-13
A-I	Test Plate, Cutter Data	31
A-II	Test Plate, Cutter Data	32
A-III	Test Plate, Cutter Data	33
A-IV	Test Plate, Cutter Data	34
A-V	Test Plate, Cutter Data	35
A-VI	Test Plate, Cutter Data	36
A-VII	Test Plate, Cutter Data	37

**1.0 PROJECT TITLE**

Numerical Control and its Application to Manufacturing

**2.0 STATEMENT OF PROBLEM**

Integration of numerically controlled methods into present and future manufacturing processes.

**3.0 OBJECTIVE AND PURPOSE**

- (1) Establish and coordinate methods and improvements generated by the development of numerically controlled machine tools,
- (2) Conduct feasibility studies on additional numerically controlled applications.

**4.0 CONCLUSIONS****4.1 The Electronic Control Systems (ECS/Morey) Machines**

The ECS/Morey machines have proved their versatility in the production of various types of machined parts. Their usefulness in machining both ferrous and non-ferrous metals has been fairly demonstrated. Errors attributed to the lead screw on the first machine built were not detrimental as was originally anticipated.

The ECS control system is considered adaptable to other kinds of control problems.

**4.2 The McKay Numerically Controlled Drilling and Counterboring Machine**

1. Initial tests on the machine revealed excessive nonconformance to specifications. Final phases of acceptance procedure were not completed as the project was cancelled; however, relevant information will be included in the Final Report on "Numerical Control," PR 862.
2. The Farrand Inductosyn scale units are very accurate, but unless great care is used in their alignment, excessive errors can easily accumulate.

**4.3 Automatic Inspection Devices**

The application of Numerical Control ( NC ) techniques to inspection processes has proved to be feasible and it is rapidly assuming a useful function in the industry.

**4.4 F-108 Wing Program**

A method was developed for converting analytical loft data to an acceptable form for numerical control use before the F-108 program was cancelled.

**4.5 General Procedures for NC Machining of Wind-Tunnel Models**

Lack of funds resulted in cancellation of attempts to develop detailed procedures.

**5.0 RECOMMENDATIONS**

This project should be continued with particular emphasis on:

1. Investigation of processes, other than machining, suitable for NC application such as inspection, welding, lofting, and template fabrication.
2. Modifications to existing NC equipment to increase utilization by applying this technology to other processes.
3. Qualification tryouts of new NC equipment.
4. Reduction of programming costs by improved data processing methods.
5. Retrofit applications.

**6.0 IMPLEMENTATION**

The Electronic Control Systems (ECS)/Morey machines have been integrated into production and have satisfactorily demonstrated their versatility. Assistance and information has been given to personnel concerned with this equipment.

All initial work necessary to the F-108 Wing program was completed before the program was cancelled.

Despite unsuccessful efforts to obtain approval of a "Request for Engineering Authorization" (REA ) for Numerically Controlled machining of wind-tunnel models, a progressive step has been made toward further activity in this field.

## 7.0 DEVELOPMENT OF THE PROJECT

### 7.1 The Electronic Control Systems-(ECS/Morey) Machines

#### 7.1.1 Background

An important facet of this project was the qualification tryouts of these two machines prior to their acceptance for production. Initial work accomplished in this task can be found in the final report, entitled "Numerical Control," RMDA SD-8-7, published March 1959. A brief review of the last phases of the tryouts described in this report shows that various changes were required to the original test programs due to new system requirements and modifications. New features on acceleration, deceleration, feeds, and other operating characteristics were incorporated into the revised programs. After new punched tapes were made on Convair's Punched Tape Preparation Unit (PTPU), they were sent to ECS for use in preparing the final control element, i. e., the magnetic tape.

#### 7.1.2 Procedures followed and results

Minor revisions were made to the punched tape by ECS prior to processing. Once the magnetic control tapes were completed, they were shipped back to Convair for continuation of qualification tryouts. While awaiting receipt of the new tapes, training in the operation of the PTPU was given to Tooling, Dept. 400-2 personnel. Programming and tape preparation for production parts was commenced in anticipation of the machine's release for production.

Qualification tryouts continued on the Morey 1, AF641592, and 2, AF641593, after receipt of the revised tapes. Further tests were run with the new tapes, primarily, Tape 1, Feed Rates, and Tape 2, Positioning Test.

During the time tests were in progress, word was received that other identical machines in the field were experiencing servo-motor troubles. Our two mills were then put on an in-operative hold status pending results of analysis on the reported damage to the other machines. After assurance was given by Morey and Diehl (motor manufacturer) that the machines were safe to run, qualification tryouts continued.

Data obtained on the tryouts was compiled, graphed, and evaluated. A report was then issued covering the results of these latest tests. See Appendix A.

The results of the Positioning Test, Test Tape 2, on the Morey 1 revealed that there was an accumulative lead-screw error on this machine. Although this result seemed doubtful at the time, other tests were performed by Production Inspection personnel which substantiated the original findings. As a result of these tests, Production Inspection suggested that a master checking tool be fabricated by Tool Inspection. Mfg. Development designed such a tool, 190-862, to be made at the machine itself. (See Figure 1.)

After fabrication, the tool was to be removed from the machine and inspected to verify the inherent positional accuracy of the machine. Due to excessive high priority workloads, however, this task was not completed.

Test Tape 3 was initially designed for stringent cut tests on both "dural" and steel plates. The tests were repeated on both machines; in general, performance was satisfactory. (See Figure 2.) The most obvious errors were overshoot and dwell. Although programming instructions were followed in detail, it soon became evident that slowdown distance was insufficient in many instances. Tooling personnel were informed of these occurrences, and proper provisions were made for improved programming procedures. See Appendix A for cutter data obtained on these tests.

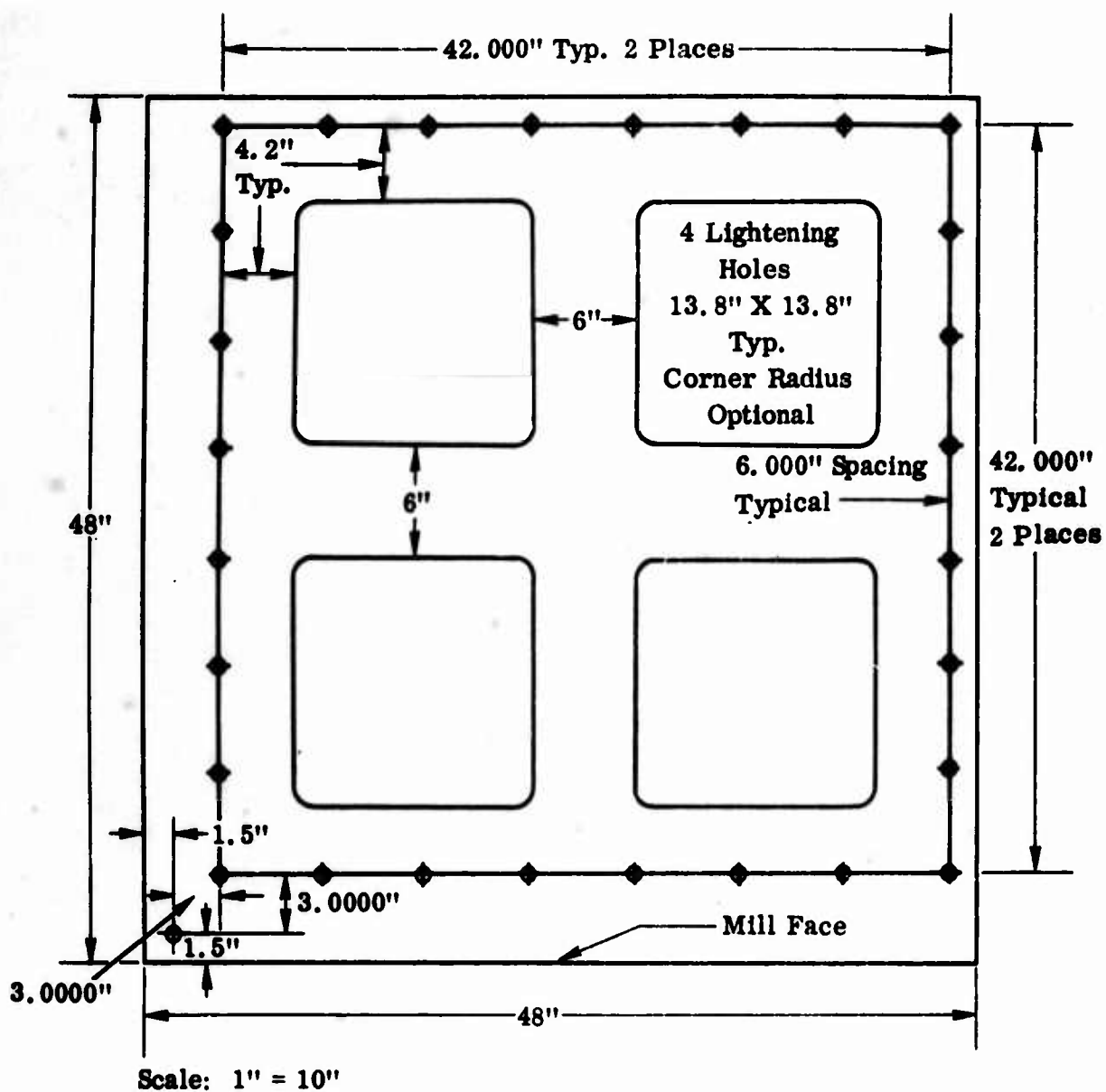

NOTES

1. HOLE SIZE - 1.00" DIA.  $\pm 0.03$ ", TO BE JIG BORED TO MAINTAIN UNIFORMITY AND CONCENTRICITY
2. HOLE SPACING -  $\pm 0.0002$ ", NON-ACCUM.
3. MAT'L. 0.75" - THICK DURALUMIN

Figure 1, Check Plate



Figure 2. Machining a "Dural" Test Plate

It is to be noted that considerable delay was caused by ECS personnel while working on these machines. Modifications and repairs hindered the rapid completion of the qualification try-outs through out their various phases. Once the tryouts were completed on a machine, however, that particular machine was immediately put into production use.

## 7.2 The McKay Numerically Controlled Drilling and Counterboring Machine

### 7.2.1 Background

Continuous attempts have been made to get this machine accepted for production use. Various performance tests have revealed its excessive nonconformance to specifications. Prior activities on acceptance testing procedures are described in the final report, "Numerical Control," RMDA SD 8-7, published March 1959.

### 7.2.2 Procedures followed and results

Due to the many unsatisfactory results obtained on previous tests, the machine was not accepted. A decision was reached to continue efforts to obtain the required performance. A new test was designed and programmed to effectively disclose the machine's ability to conform to specifications.

The test consisted of drilling, under tape control, six plates placed in an appropriate pattern (see Figure 3). The region covered by these plates encompassed most of the machine's workable area. By properly spacing these plates, a comparable test could be made to one previously made with a large sheet, 113" x 199"; at the same time, the small plates would facilitate inspection procedures. A test program was designed in which a common hole pattern was drilled in each plate (see Figure 4), with provisions and exceptions made where necessary to avoid interference with fixture members. The full acceptance test program is given in Table I.

A team of three Convair representatives spent four days at the McKay factory to check-out the machine. The above program, in hand-written manuscript form, and the necessary plates were delivered to McKay for the drilling test.

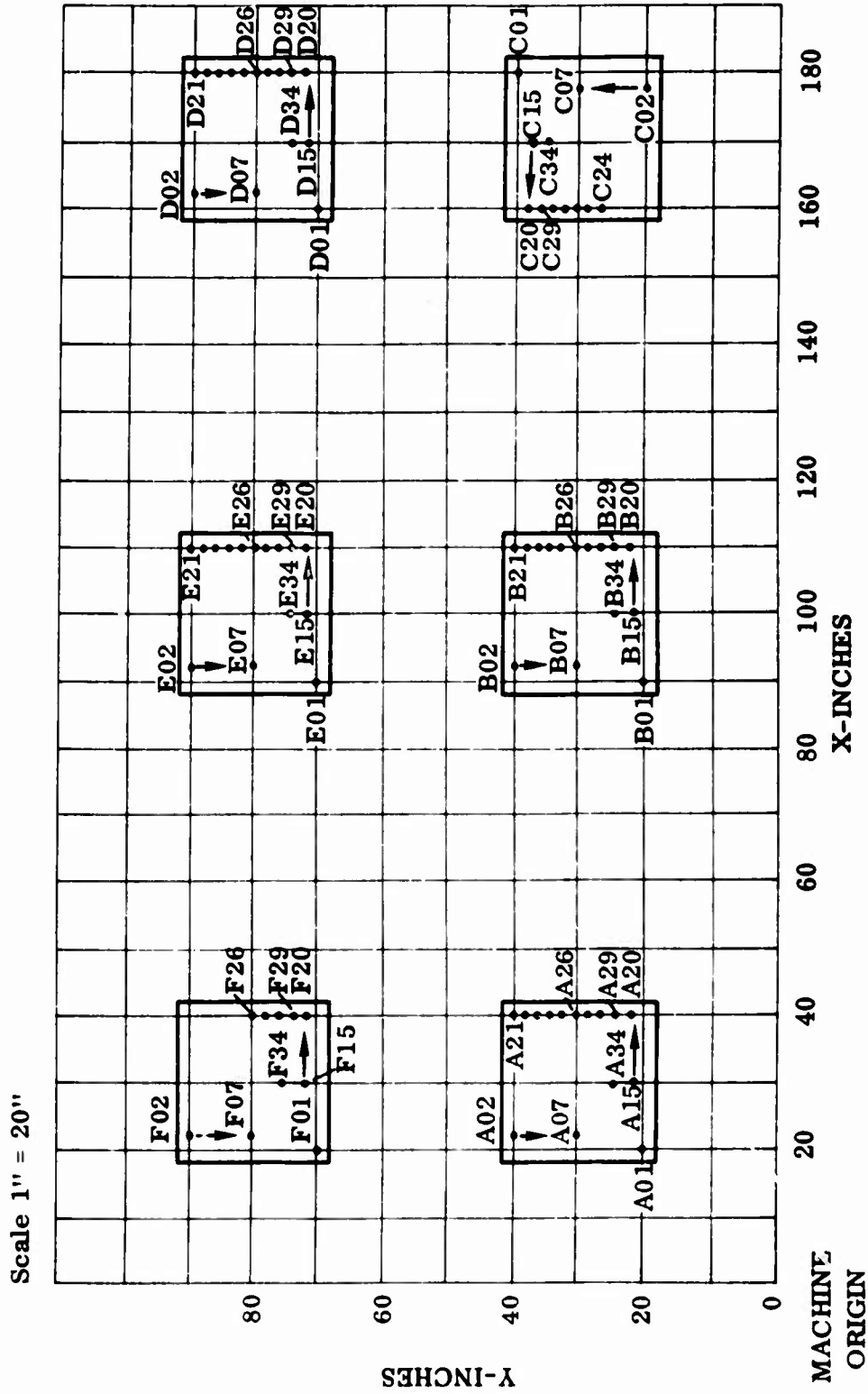

Shows the position of the plates and the 10" incremental grid spacing of holes at check points. Letter prefix of point callouts refer to plate identity.

Figure 3, McKay Test Plates, Set III

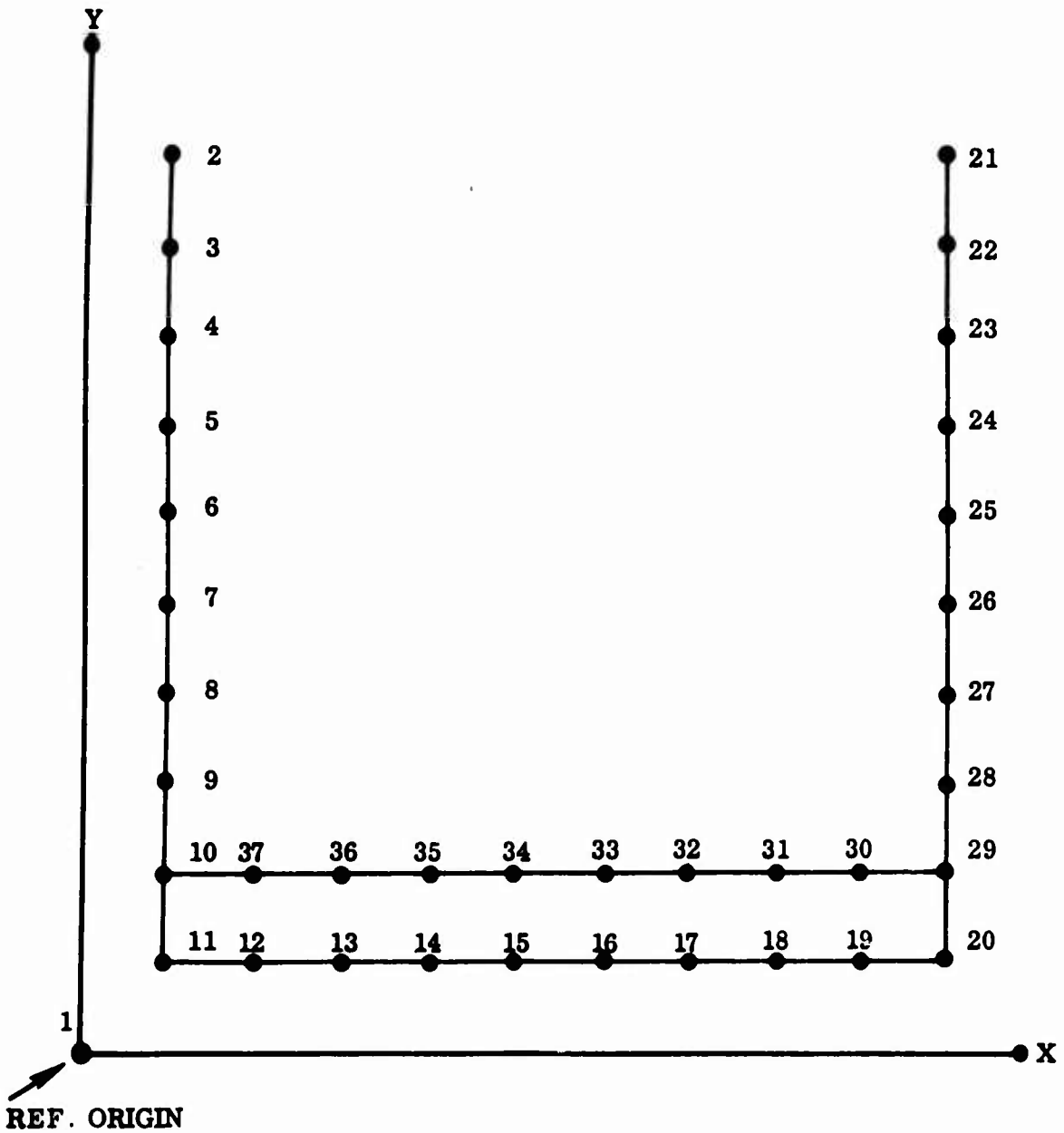

- NOTES:
1. Pattern on "C" Plate rotated 180°. Holes 21-23 inclusive not drilled.
  2. Plate "F," Holes 21-25 inclusive not drilled.

Figure 4. McKay Test Plates Set III Typical Pattern

Table I. McKay Drill and Counterbore Acceptance Test Program (SHT 1)

	"X"	"Y"	DRILL	POINT	"X"	"Y"	DRILL	POINT	"X"	"Y"	DRILL	POINT	"X"	"Y"	DRILL
	COORD.	COORD.	COORD.	COORD.	COORD.	COORD.	COORD.	COORD.	COORD.	COORD.	COORD.	COORD.	COORD.	COORD.	COORD.
A01	20.0	20.0	A	B01	90.0	20.0	A	C01	180.0	40.0	A				
A02	22.0	40.0	A	B02	92.0	40.0	A	C02	178.0	20.0	A				
A03	22.0	38.0	B	B03	92.0	38.0	B	C03	178.0	22.0	B				
A04	22.0	36.0	A	B04	92.0	36.0	A	C04	178.0	24.0	A				
A05	22.0	34.0	B	B05	92.0	34.0	B	C05	178.0	26.0	B				
A06	22.0	32.0	A	B06	92.0	32.0	A	C06	178.0	28.0	A				
A07	22.0	30.0	B	B07	92.0	30.0	B	C07	178.0	30.0	B				
A08	22.0	28.0	A	B08	92.0	28.0	A	C08	178.0	32.0	A				
A09	22.0	26.0	B	B09	92.0	26.0	B	C09	178.0	34.0	B				
A10	22.0	24.0	A	B10	92.0	24.0	A	C10	178.0	36.0	A				
A11	22.0	22.0	B	B11	92.0	22.0	B	C11	178.0	38.0	B				
A12	24.0	22.0	A	B12	94.0	22.0	A	C12	176.0	38.0	A				
A13	26.0	22.0	B	B13	96.0	22.0	B	C13	174.0	38.0	B				
A14	28.0	22.0	A	B14	98.0	22.0	A	C14	172.0	38.0	A				
A15	30.0	22.0	B	B15	100.0	22.0	B	C15	170.0	38.0	B				
A16	32.0	22.0	A	B16	102.0	22.0	A	C16	168.0	38.0	A				
A17	34.0	22.0	B	B17	104.0	22.0	B	C17	166.0	38.0	B				
A18	36.0	22.0	A	B18	106.0	22.0	A	C18	164.0	38.0	A				
A19	38.0	22.0	B	B19	108.0	22.0	B	C19	162.0	38.0	B				
A20	40.0	22.0	A	B20	110.0	22.0	A	C20	160.0	38.0	A				

Table I. McKay Drill and Counterbore Acceptance Test Program (SHT 2)

	<u>"X"</u>	<u>"Y"</u>	<u>COORD.</u>	<u>DRILL</u>	<u>POINT</u>	<u>COORD.</u>	<u>"X"</u>	<u>"Y"</u>	<u>COORD.</u>	<u>DRILL</u>	<u>POINT</u>	<u>COORD.</u>	<u>"X"</u>	<u>"Y"</u>	<u>COORD.</u>	<u>DRILL</u>
D01	160.0	70.0	A	E01	90.0	70.0	A	F01	20.0	70.0	A	F01	20.0	70.0	A	
D02	162.0	90.0	A	E02	92.0	90.0	A	F02	22.0	90.0	A	F02	22.0	90.0	A	
D03	162.0	88.0	B	E03	92.0	88.0	B	F03	22.0	88.0	B	F03	22.0	88.0	B	
D04	162.0	86.0	A	E04	92.0	86.0	A	F04	22.0	86.0	A	F04	22.0	86.0	A	
D05	162.0	84.0	B	E05	92.0	84.0	B	F05	22.0	84.0	B	F05	22.0	84.0	B	
D06	162.0	82.0	A	E06	92.0	82.0	A	F06	22.0	82.0	A	F06	22.0	82.0	A	
D07	162.0	80.0	B	E07	92.0	80.0	B	F07	22.0	80.0	B	F07	22.0	80.0	B	
D08	162.0	78.0	A	E08	92.0	78.0	A	F08	22.0	78.0	A	F08	22.0	78.0	A	
D09	162.0	76.0	B	E09	92.0	76.0	B	F09	22.0	76.0	B	F09	22.0	76.0	B	
D10	162.0	74.0	A	E10	92.0	74.0	A	F10	22.0	74.0	A	F10	22.0	74.0	A	
D11	162.0	72.0	B	E11	92.0	72.0	B	F11	22.0	72.0	B	F11	22.0	72.0	B	
D12	164.0	72.0	A	E12	94.0	72.0	A	F12	24.0	72.0	A	F12	24.0	72.0	A	
D13	166.0	72.0	B	E13	96.0	72.0	B	F13	26.0	72.0	B	F13	26.0	72.0	B	
D14	168.0	72.0	A	E14	98.0	72.0	A	F14	28.0	72.0	A	F14	28.0	72.0	A	
D15	170.0	72.0	B	E15	100.0	72.0	B	F15	30.0	72.0	B	F15	30.0	72.0	B	
D16	172.0	72.0	A	E16	102.0	72.0	A	F16	32.0	72.0	A	F16	32.0	72.0	A	
D17	174.0	72.0	B	E17	104.0	72.0	B	F17	34.0	72.0	B	F17	34.0	72.0	B	
D18	176.0	72.0	A	E18	106.0	72.0	A	F18	36.0	72.0	A	F18	36.0	72.0	A	
D19	178.0	72.0	B	E19	108.0	72.0	B	F19	38.0	72.0	B	F19	38.0	72.0	B	
D20	180.0	72.0	A	E20	110.0	72.0	A	F20	40.0	72.0	A	F20	40.0	72.0	A	

Table I. McKay Drill and Counterbore Acceptance Test Program (SHT 3)

	"X"	"Y"	DRILL	POINT	"X"	"Y"	COORD.	COORD.	DRILL	POINT	"X"	"Y"	COORD.	COORD.	DRILL
	COORD.	COORD.	COORD.	COORD.	COORD.	COORD.	COORD.	COORD.	COORD.	COORD.	COORD.	COORD.	COORD.	COORD.	COORD.
A21	40.0	40.0	A	B24	110.0	34.0	B	C30	162.0	36.0	B				
A22	40.0	38.0	B	B25	110.0	32.0	A	C31	164.0	36.0	A				
A23	40.0	36.0	A	B26	110.0	30.0	B	C32	166.0	36.0	B				
A24	40.0	34.0	B	B27	110.0	28.0	A	C33	168.0	36.0	A				
A25	40.0	32.0	A	B28	110.0	26.0	B	C34	170.0	36.0	B				
A26	40.0	30.0	B	B29	110.0	24.0	A	C35	172.0	36.0	A				
A27	40.0	28.0	A	B30	108.0	24.0	B	C36	174.0	36.0	B				
A28	40.0	26.0	B	B31	106.0	24.0	A	C37	176.0	36.0	A				
A29	40.0	24.0	A	B32	104.0	24.0	B	D21	180.0	90.0	A				
A30	38.0	24.0	B	B33	102.0	24.0	A	D22	180.0	88.0	B				
A31	36.0	24.0	A	B34	100.0	24.0	B	D23	180.0	86.0	A				
A32	34.0	24.0	B	B35	98.0	24.0	A	D24	180.0	84.0	B				
A33	32.0	24.0	A	B36	96.0	24.0	B	D25	180.0	82.0	A				
A34	30.0	24.0	B	B37	94.0	24.0	A	D26	180.0	80.0	B				
A35	28.0	24.0	A	C24	160.0	26.0	B	D27	180.0	78.0	A				
A36	26.0	24.0	B	C25	160.0	28.0	A	D28	180.0	76.0	B				
A37	24.0	24.0	A	C26	160.0	30.0	B	D29	180.0	74.0	A				
B21	110.0	40.0	A	C27	160.0	32.0	A	D30	178.0	74.0	B				
B22	110.0	38.0	B	C28	160.0	34.0	B	D31	176.0	74.0	A				
B23	110.0	36.0	A	C29	160.0	36.0	A	D32	174.0	74.0	B				

Table I. McKay Drill and Counterbore Acceptance Test Program (SHT 4)

	<u>"X"</u>		<u>"Y"</u>		
<u>POINT</u>	<u>COORD.</u>	<u>COORD.</u>	<u>COORD.</u>	<u>COORD.</u>	<u>DRILL</u>
			<u>"X"</u>	<u>"Y"</u>	
			<u>POINT</u>	<u>COORD.</u>	<u>DRILL</u>
D33	172.0	74.0	E36	96.0	B
D34	170.0	74.0	E37	94.0	A
D35	168.0	74.0	F26	40.0	B
D36	166.0	74.0	F27	40.0	A
D37	164.0	74.0	F28	40.0	B
E21	110.0	90.0	F29	40.0	A
E22	110.0	88.0	F30	58.0	B
E23	110.0	86.0	F31	36.0	A
E24	110.0	84.0	F32	34.0	B
E25	110.0	82.0	F33	32.0	A
E26	110.0	80.0	F34	30.0	B
E27	110.0	78.0	F35	30.0	A
E28	110.0	76.0	F36	26.0	B
E29	110.0	74.0	F37	24.0	A
E30	108.0	74.0			B
E31	106.0	74.0			A
E32	104.0	74.0			B
E33	102.0	74.0			A
E34	100.0	74.0			B
E35	98.0	74.0			A

Various malfunctions occurred during the test program, some of which were corrected at the time. When the program run was completed, tests were made to prove axes alignment and positioning accuracy by using optical instruments and United States Bureau of Standards tapes. Although the axial alignment was satisfactory, positioning accuracy along each axis was unsatisfactory. Both "X" and "Y" errors were excessive, ranging up to 0.027" on "Y" and 0.016" on "X". With allowances made for particular errors, checks were repeated and found satisfactory. Results obtained proved the positioning and repeatability accuracy of the Farrand Control system when working within a particular 10"-scale component. They also proved that the Inductosyn scales had not been properly aligned during the first test, resulting in large errors as scale misplacements accumulated along each axis.

The six plates were shipped back to Convair-San Diego and subjected to precision inspection on a jig-boring machine. Since each plate was individually inspected, all data obtained is relative to hole (1) on each plate. For orientation, the 2 inch "X" spacing between holes (1) and (2) was maintained. This method enabled accuracies to be observed within particular areas of the McKay machine. It was not possible, however, to satisfactorily determine actual accumulated dimensions between plates or from the program origin. Deviation data in graphical form is presented in Appendix B.

Various other significant events were also occurring while data was being compiled and analyzed. An analysis chart was made by Industrial Engineering to illustrate the savings possible on production runs of six F-106 wing skins if acceptance and production schedules were adhered to. Industrial Engineering also made an evaluation of the machine's potential adaptations for the F-108 program. Among the suggested uses were: butt weld, honeycomb core splice, vapor blast and ultrasonic inspection of brazed panels.

A joint meeting of the departments concerned was held, and it was agreed to obtain the first McKay machine for the original reason, the drilling of wing skins. Mfg. Development immediately proceeded to develop qualification tryout procedures to be accomplished after satisfactory machine installation at Plant II.

The qualification tryout procedures for the first machine were detailed in two sections. Section one concerned the reproduction of six plates drilled at the McKay factory. Repeatability tests were to be made, following which the plates were to be removed and inspected. Section two pertained to the actual drilling of a scrap, or simulated, wing skin. Each Section was broken-down in phases, each with its corresponding time estimate.

While awaiting delivery and installation of the machine, the project was cancelled.

### 7.3 Automatic Inspection Devices

#### 7.3.1 Background

Two projects had previously been completed on facets of inspection problems under Request for Mfg. Development Authorization (RMDA) sponsorship. Prior attempts to investigate and evaluate numerical control technology applicable to inspection processes are reviewed in the following final reports: "Inspection Methods for Numerically Controlled Machines" RMDA SD-8-14-2, WO 7908, Published August 1958, and "Automatic Inspection of Machined Parts," RMDA SD-8-15, WO 7909, published May 1959.

#### 7.3.2 Procedures followed and results

Further research in this field was considered desirable, so data and information were gathered and compiled into an RMDA for Automatic Inspection Devices. A formal proposal in the form of a brochure to design, construct, test and evaluate an Automatic Inspection Device would have been the final results of this RMDA. Figure 5, Sheets 1 and 2, shows a copy of this RMDA.

The RMDA was submitted to Management for approval and funding, but was subsequently denied. A brochure on this subject was later completed under the present project for presentation to a customer. See Appendix C.





#### 7.4 F-108 Wing Program

At the inception of the F-108 program, many problem areas appeared which had never been encountered in an initial tooling and production program. In the solution of these problems, the intent was to supplement, not duplicate, the work done in this field by North American Aviation (NAA). Numerical control (NC) was one area in which active development work was anticipated.

The initial approach in solving NC problems was to diligently review the problem areas, and then state and describe them. Among the areas which required NC development work were the following:

##### 7.4.1 Analytical lofting

Due to Convair's inexperience in analytical lofting by NC methods, advance information from NAA was required. It was necessary to put this information into a suitable form for integration into Convair procedures. Specific steps judged desirable were:

The determination of the form of analytical information to be received from NAA.

The development of computer routines required to translate NAA information into a form suitable for Convair NC equipment.

The development of optimum procedures to implement Production use of the information.

The development of optimum procedures to implement changes as they arose.

##### 7.4.2 Master and production tooling

Of prime importance to the F-108 program was the close-tolerance requirements for the whole wing. Numerical control techniques were the only ones known to be capable of meeting these requirements. In addition, lead-time schedules excluded the use of conventional procedures. Items pertinent to the phase were:

The development of optimum methods for translating analytical information into machine-control language, so that templates could be machined for master tooling.

Assistance to Tooling in the development of optimum procedures to effect fabrication of master tools.

Coordination with other Departments concerned in the development of procedures for programming and fabrication of detail tooling.

The development of methods which would result in the required detail tooling necessary to maintain inside contours during brazing operations.

#### 7.4.3 Machining by numerically controlled methods

Problems relative to the NC machining of production parts were of a varied nature, but the following were predominant:

The determination, through tests, of optimum feed rates and horsepower requirements for materials to be used.

The development of programs for machining contours, in the flat, prior to forming honeycomb.

The development of programs and procedures for belt sanding contoured honeycomb by NC methods.

The expansion to Production use of NAA developments in hold-down procedures for machining templates with minimum clamps.

The development of NC programming techniques for machine parts and fixtures, so that the same tapes could be used for welding control.

#### 7.4.4 Retrofit applications

Assistance would be required by Departments concerned in the modification of equipment for NC. This assistance would include the development of programming methods.

#### 7.4.5 Inspection methods

Coordination with Quality Control in the development of NC inspection methods.

The NC Group in Manufacturing Development was primarily engaged in the related problems of analytical lofting and the conversion of analytical wing data to machine control information.

Several trips were made to NAA to expedite the acquisition of the final machine-control tape.

Analytical data on the entire wing was available at NAA. North American was programming computer routines to give outside mold-line numerical data; with the introduction of varying skin thickness, inside mold-line numerical data would also be obtainable. An interconnecting routine for the Automatically Programmed Tool (APT) system was also available at NAA; however, modifications were necessary to effect maximum automation. These routines would greatly facilitate programming efforts for the NC machining of master templates directly from analytical information.

Convair desired to receive NC information from NAA in the form of a magnetic control tape for its Giddings and Lewis machines. Due to tight production schedules, a recommendation was made for a working agreement between Convair and NAA, since assistance from Convair in completing the desired computer routines would help ensure the fulfillment of production schedules. Cooperation was maintained with NAA, but the task was not completed as the project was cancelled.

### 7.5 General Procedures for NC Machining of Models

#### 7.5.1 Background

In May 1958 Manufacturing Development at Convair San Diego satisfactorily fabricated the complex contours of a wind-tunnel model wing by using a technique relatively new to the industry. The contours were machined by numerically controlled processes; this proved the feasibility and economies of machining models

by this new technology. Information on the project can be found in the interim report entitled "Numerically Controlled Machining of Wind Tunnel Model Wing," RMDA 8-7 published in October 1958. This report was also included in the final report on "Numerical Control," published March 1959 under the same RMDA number.

#### 7.5.2 Procedures followed and results

As a result of this initial work, the Engineering Department was made cognizant of the many advantages of this technology. Interest led to a firm desire by Engineering to submit a Request for Engineering Authorization (REA) for the "Development of General Methods and Techniques for Setting-up NC Machining of Wind Tunnel Models." Various Departments were requested to furnish estimates of the departmental tasks involved and other related matters.

Manufacturing Development submitted an outline and estimate for the task its NC Group was to perform. Consideration was given to the production of both a model wing for the 880 and an F-106 fuselage. Some excerpts from this outline are as follows:

#### OUTLINE:

1. Assist in preliminary planning to obtain cutter center path from computer, and help to determine cutter geometry. This does not include math analysis or computer programming.
2. Select feeds and speeds.
3. Outline and coordinate procedures for writing final Electronic Control Systems (ECS) manuscripts.
4. Machining of part:
  - Coordination.
  - Pre-machining of blank.
  - Epoxy fixture.
  - NC machining, including set-up.

## 5. Estimate labor:

Item	880 Wing	F-106 Fuselage
1.	70 hours	140 hours
2.	30 hours	60 hours
3.	80 hours	160 hours
4.	80 hours	160 hours
Totals	260 hours	520 hours

Engineering Department assembled the various estimates and included them in an REA, sections of which are as follows:

## Section 1. Work to be Done

Work out general procedure for 3-dimensional contouring of models using numerically controlled machines:

Study of general equations of surfaces of model components.

Develop computer program required to define the wing and fuselage surfaces.

Develop computer program required to give proper cutter offset points.

Fabricate Model-30-type wing (semi-span) and Model-8-type fuselage on the Morey A-50 Profiler.

Make recommendations and time and cost study for future work on actual test vehicles.

No hand finishing to be performed.

A cost proposal will be included.

A Convair Aerodynamics report is now being prepared which contains information on previous work done in this field.

**Sections 2. & 3. Implications for Future and Why Should it be Done**

To produce higher quality models with less lead time and at a lower cost. To keep up with competition and with the state-of-the-art. Experience gained can cut lead time on future projects and can be applied to actual missile and aircraft components.

**Section 4. Correlation with Long-Range Plans**

To encourage the use of mathematically described aircraft lines and surfaces at Convair.

**Sections 5. & 6. Manpower Required and Men Made Available**

Aerodynamics Engineer, 1 Wind-tunnel Design Engineer, 1 Linesman (part time). Assistance from the Digital Computer Laboratory, Numerical Control and Manufacturing Development. Since this program could be beneficial to all future model work, no anticipatory costs are claimed.

Cost Estimate	
Cost - Model-30-type wing (semi-span)	\$17, 886. 00
Cost - Model-8-type fuselage	<u>\$28, 265. 00</u>
Total cost of Project	\$46, 151. 00

The REA was not approved.

**8.0 ACKNOWLEDGMENTS**

Appreciation is expressed to the following departments for cooperating in the successful completion of this project:

Digital Computing Laboratory	Dept. 6-35, Function 68
Engineering Dept. , Aerodynamics	Dept. 6-35
Industrial Engineering, Facilities Control	Dept. 8-5
Inspection Dept. , Plant 2	Dept. 188-2
Machine Shop, Plant 2	Dept. 215
Plant Engineering, Plant 2	Dept. 25
Tool & Die Shop, Plant 1	Dept. 403
Tooling, Plant 2	Dept. 400-2

## 9.0 BIBLIOGRAPHY

"How to Prepare A Planning Sheet," Electronic Control Systems, Los Angeles, Calif. , Preliminary Edition-ECS, R-1, June 18, 1958.

"Operating Instructions for Two-Axis Drilling Machine Control," Farrand Controls, New York, ER 314.19, Sept. , 1957.

**APPENDIX A**

**Data on the Electronic Control Systems/Morey Machines**

MOREY PROFILE MILLING MACHINESAnalytical TestsMOREY No. 1.

<u>Test No.</u>	<u>Name of Test</u>	<u>NAS Spec.</u>	<u>Mfg. Dev.</u>	<u>Meets Spec.</u>
1	Runout, spindle nose to work table, longitudinally	±.001/ft. max. full length ±.0025	-.0001/ft.  -.0025	YES  YES
2	Runout, spindle nose to work table, transversely	±.001/ft. max. full width ±.0025	-.0001/ft.  -.0025	YES  YES
3	Depth slide movement of head, runout	Trans. .0006/ft. Long. .0006/ft.	.0006/ft.  .0012/ft.	YES  NO
4	Spindle parallel with housing	Trans. .001/ft. Long. .001/ft.	.0003/ft.  .0003/ft.	YES  YES
5	Displacement during locking	.001 at 12" from spindle nose	.0006 long. .0003 trans.	YES  YES
6	Spindle-face axial runout	Max. .0004	.0002	YES
7	Spindle-face radial runout	Max. .0004	.0001	YES
8	Spindle runout 1 1/4" from face 12" from face	Max. .0005 Max. .001	.0002 .0023	YES NO
9	Center T-slot Parallel with table Square with saddle	Not listed	.0000 .0012/12"	_____ _____

MOREY PROFILE MILLING MACHINESAnalytical TestsMOREY No. 2.

<u>Test No.</u>	<u>Name of Test</u>	<u>NAS Spec.</u>	<u>Mfg. Dev.</u>	<u>Meets Spec.</u>
1	Runout, spindle nose to work table, longitudinally	±.001/ft. Max. full length ±.0025	.001/ft.  .001	YES  YES
2	Runout, spindle nose to work table, transversely	±.001/ft. Max. full width ±.0025	.0005/ft.  .002	YES  YES
3	Depth slide movement of head, runout	Trans. .0006/ft. Long. .0006/ft.	.0033/ft.  .0021/ft.	NO  NO
4	Spindle parallel with housing	Trans. .001/ft. Long. .001/ft.	.0048/ft.  .0013/ft.	NO  NO
5	Displacement during locking	.001 at 12" from spindle nose	.0000 long. .0000 trans.	YES  YES
6	Spindle-face axial runout	Max. .0004	.0002	YES
7	Spindle-face radial runout	Max. .0004	.0002T.I.R.	YES
8	Spindle runout 1 1/4" from face 12" from face	Max. .0005 Max. .001	.0015T.I.R. constant	NO NO
9	Center T-slot Parallel with table Square with saddle	Not listed	.0000 .0000/14"	_____ _____

T.I.R. = TOTAL INDICATOR READING

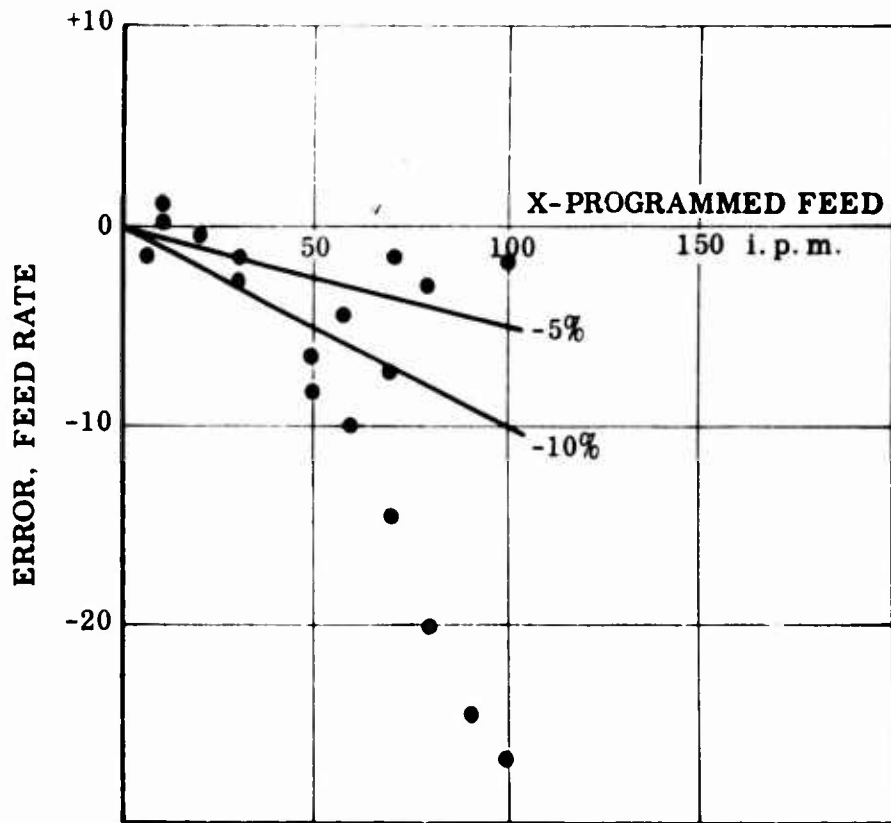

Figure A-1 Morey No. 1 Test Tape No. 1, Feed Rates, X-axis

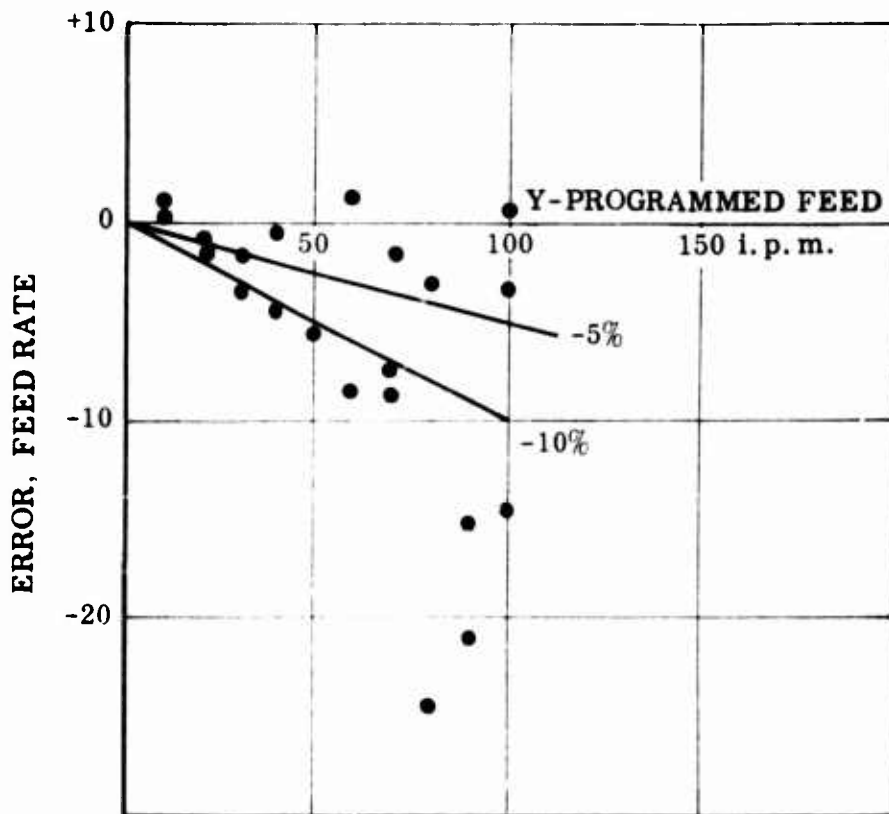

Figure A-2 Morey No. 1, Test Tape No. 1, Feed Rates, Y-axis

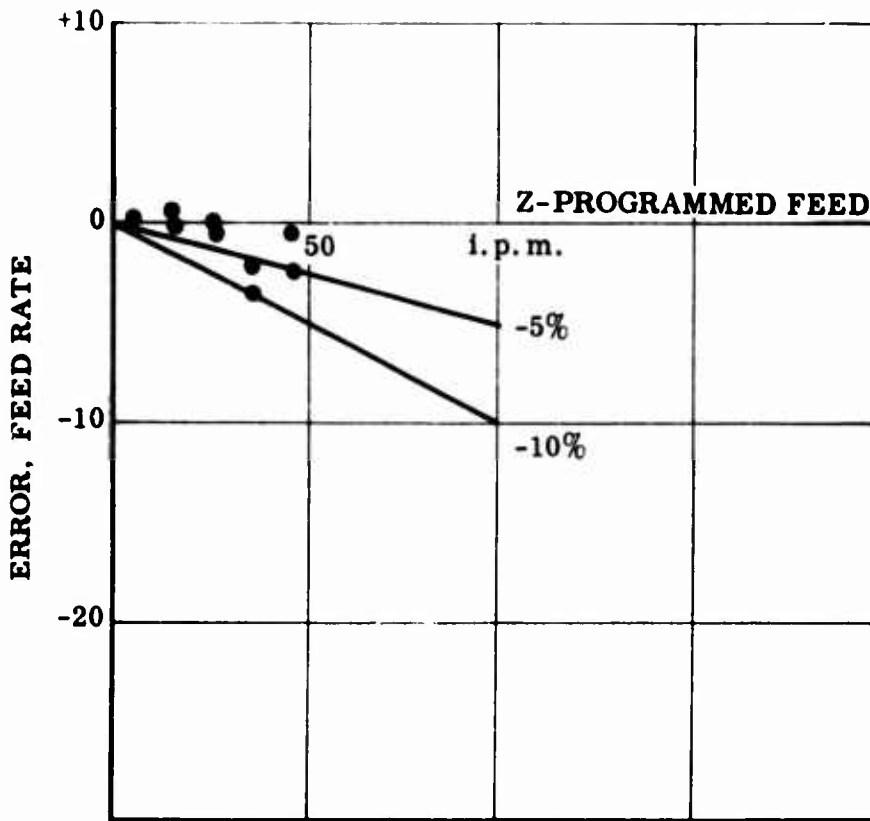

Figure A-3 Morey No. 1, Test Tape No. 1, Feed Rates, Z-axis

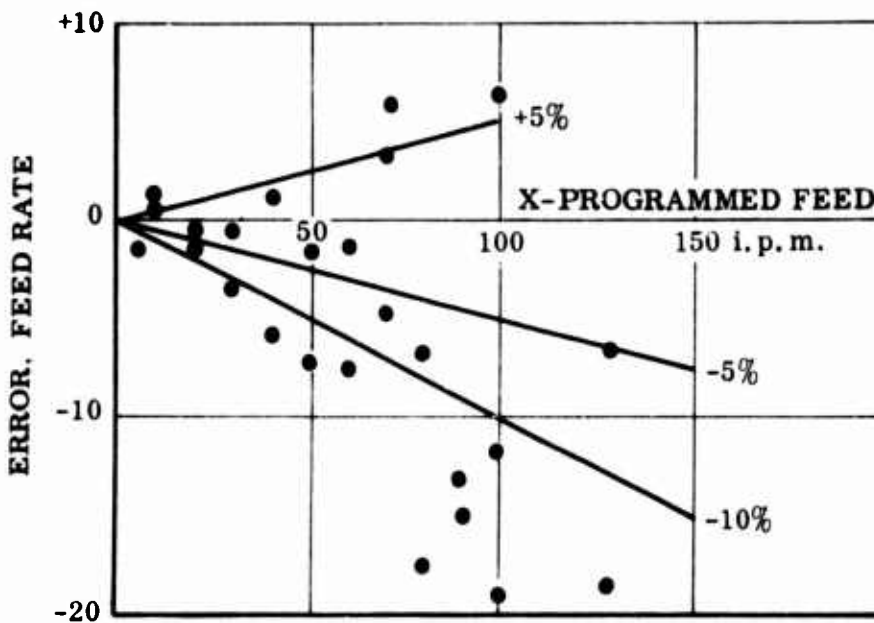

Figure A-4 Morey No. 2, Test Tape No. 1, Feed Rates, X-axis

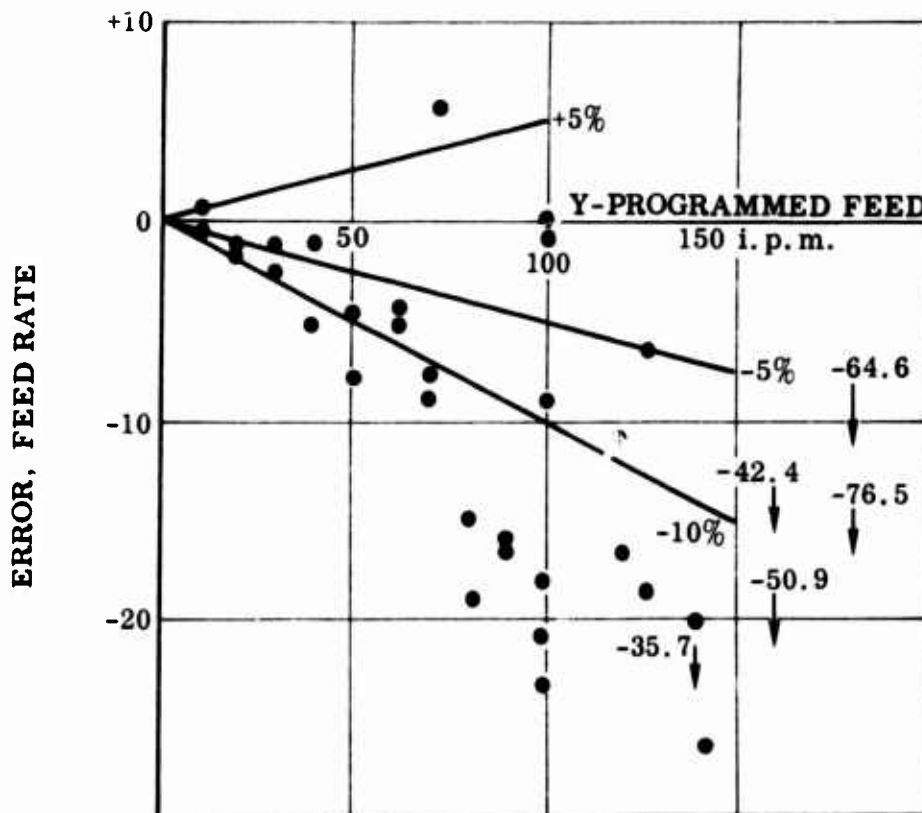

Figure A-5 Morey No. 2, Test Tape No. 1, Feed Rates, Y-axis

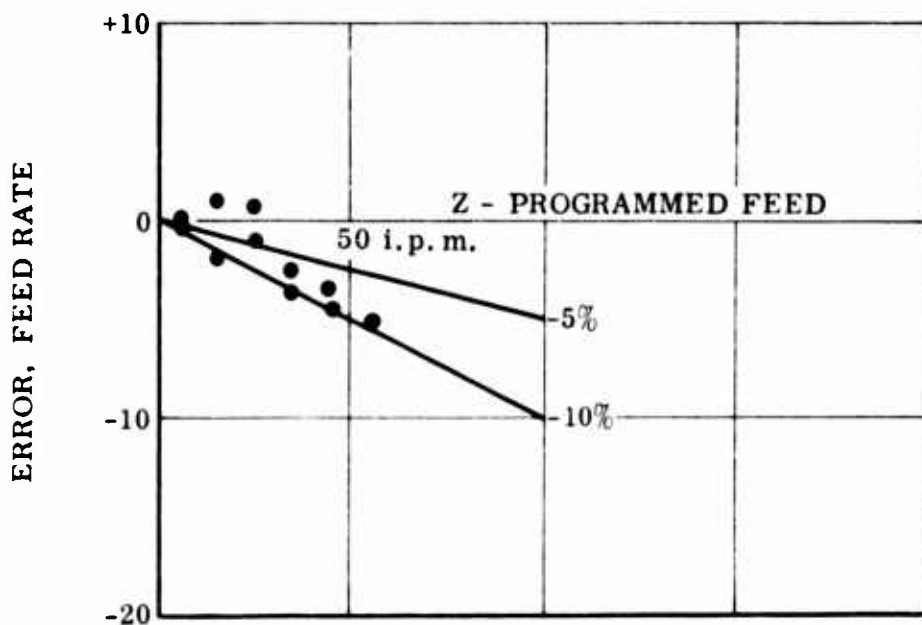

Figure A-6 Morey No. 2, Test Tape No. 1, Feed Rates, Z-axis

CUTTER NO. S-1  
 CUTTER MAT'L M-3, Type 2  
 1/20/59

Machine Used Morey #1-N/C - Pl. II  
 Material Machined Duralumin

Work Piece Good - G  
 \*Condition Fair - F  
Poor - P

Cutter Geometry

A. Cutter Dia. 1.230 F. Radial Rake \_\_\_\_\_  
 B. Flute Length 1.75 G. Prim. Land 7°  
 C. Shank Dia. 1.250 H. Secondary Land \_\_\_\_\_  
 D. No. of Flutes 2 I. Radius Ball nose  
 E. Helix Angle 30° J. Grind # \_\_\_\_\_

Cut No.	Length	Plunge	Prof.	Depth	Width	Feed	H. P.	Load per Tooth	R. P. M.	Finish	Micro-	
											Inch	*Cond.
1	18.03	Taper		.25-1.25	.50-.62	40	8-14	.0056	3600			
2	18.03	Taper		.25-1.25	.50-.62	40	8-15	.0056	3600			
3	18.03	Taper		1.25-.25	.62-.50	40	15-5	.0056	3600			
4	18.03	Taper		1.25-.25	.62-.50	40	15-8	.0056	3600			
5	6.40	Taper		.25-1.25	.99-1.23	35	8-25	.0049	3600			
6	5.75	X		1.25	1.23	35	25	.0049	3600			
7	6.40	Taper		1.25-.25	1.23-.99	35	25-8	.0049	3600			

REMARKS

Table A-I, Test Plate, Cutter Data

CUTTER NO. S-2  
 CUTTER MAT'L M-3, Type 2  
 1/20/59  
 \*Work Piece  
 Condition  
 Good - G  
 Fair - F  
 Poor - P

Cutter Geometry

A. Cutter Dia. 1.241 F. Radial Rake \_\_\_\_\_ Machine Used Morey #1 - N/C - Pl. II

B. Flute Length 1.60 G. Prim. Land 7° Material Machined Duralumin

C. Shank Dia. 1.250 H. Secondary Land \_\_\_\_\_

D. No. of Flutes 2 I. Radius .12

E. Helix Angle 30° J. Grind #- \_\_\_\_\_

Cut No.	Length	Plunge	Prof.	Depth	Width	Feed	H. P.	Load per		R. P. M.	Finish	*Cond.	REASON
								Tooth	G F P				
1	18.04		X	.750	1.240	35	17	.0049		3600			
2	-	X		.750	1.240	12	13	.0017		3600			
3	11.78		X	.750	1.240	35	19	.0049		3600			
4	-	X		.750	1.240	12	15	.0017		3600			
5	14.5		X	.750	1.240	35	18	.0049		3600			
6	9.25		X	.750	1.240	35	18	.0049		3600			
7	14.5		X	.750	1.240	35	18	.0049		3600			
8	9.25		X	.750	1.240	35	18	.0049		3600			

REMARKS

Table A-II, Test Plate, Cutter Data





CUTTER NO. S-2  
 CUTTER MAT'L M-3, Type 2  
3/20/59

\*Work Piece  
 Condition

Good - G  
 Fair - F  
 Poor - P

Cutter Geometry

- A. Cutter Dia. 1.241 F. Radial Rake \_\_\_\_\_ Machine Used Morey #2 - N/C - Pl. II
- B. Flute Length 1.60 G. Prim. Land 7° Material Machined Duralumin
- C. Shank Dia. 1.250 H. Secondary Land \_\_\_\_\_
- D. No. of Flutes 2 I. Radius .12
- E. Helix Angle 30° J. Grind #- \_\_\_\_\_

Cut No.	Length	Plunge	Prof.	Depth	Width	Feed	H.P.	Load per Tooth	R. P. M.	Finish	Micro-	
											Inch	*Cond.
										G	F	P
1	18.04	X		.750	1.240	35	18.5	.0049	3600			
2	-	X		.750	1.240	12	17.0	.0017	3600			
3	11.78		X	.750	1.240	35	19.0	.0049	3600			
4	-	X		.750	1.240	12	8.0	.0017	3600			
5	14.25		X	.750	1.240	35	18.0	.0049	3600			
6	9.25		X	.750	1.240	35	18.0	.0049	3600			
7	14.25		X	.750	1.240	35	18.0	.0049	3600			
8	9.25		X	.750	1.240	35	18.0	.0049	3600			

REMARKS

Cut #4. This was not a full cut because of a previous cut in the area.

Table A-V, Test Plate, Cutter Data

CUTTER NO. S-1  
 CUTTER MAT'L M-3, Type 2  
 3/20/59

\*Work Piece  
 Condition

Good - G  
 Fair - F  
 Poor - P

- Cutter Geometry
- A. Cutter Dia. 1.230
  - B. Flute Length 1.75
  - C. Shank Dia. 1.250
  - D. No. of Flutes 2
  - E. Helix Angle 30°
  - F. Radial Rake \_\_\_\_\_
  - G. Prim. Land 7°
  - H. Secondary Land \_\_\_\_\_
  - I. Radius Ball nose
  - J. Grind #- \_\_\_\_\_

Machine Used Morey #2 - N/C - Pl. II  
 Material Machined 4130 - Steel

Cut No.	Length	Plunge	Prof.	Depth	Width	Feed	H.P.	Load per Tooth	R. P. M.	Finish	*Cond.	REASON
1	18.03	Taper		.25	.50-.62	7.0	6	.0055	640			
2	18.03	Taper		.25	.50-.62	7.0	6	.0055	640			
3	18.03	Taper		.25	.62-.50	7.0	6	.0055	640			
4	18.03	Taper		.25	.62-.50	7.0	6	.0055	640			
5	-	X		.25	0-.99	3.3	10	.0026	640			
6	6.40	Taper		.25	.99-1.23	3.3	5	.0026	640			
7	5.75	X		.25	1.23	3.3	5	.0026	640			
8	6.40	Taper		.25	1.23-.99	3.3	5	.0026	640			

REMARKS

Cut #5. A plunge to start a three dimensional taper. Although only 10 hp, bad chips were produced. This created poor surface finish and unequal depth on return to same point.

Table A-VI, Test Plate, Cutter Data

CUTTER NO. S-2      \*Work Piece      Good - G  
 CUTTER MAT'L M-3, Type 2      Condition      Fair - F  
 3/20/59      Poor - P

Machine Used      Morey #2 - N/C - Pl. II  
Material Machined      4130 - Steel

Cutter Geometry

- A. Cutter Dia. 1.241      F. Radial Rake \_\_\_\_\_
- B. Flute Length 1.60      G. Prim. Land 7°
- C. Shank Dia. 1.250      H. Secondary Land \_\_\_\_\_
- D. No. of Flutes 2      I. Radius .12 / -
- E. Helix Angle 30°      J. Grind #- \_\_\_\_\_

Cut No.	Length	Plunge	Prof.	Depth	Width	Feed	H.P.	Tooth	Load per	R.P.M.	Finish	*Cond.	Micro-	
													Inch	Reason
1	18.04	X		.25	1.24	5	4.0	.0078		320				
2	-	X		.25	1.24	2	8.0	.0031		320				
3	11.78		X	.25	1.24	5	4.0	.0078		320				
4	-	X		.25	1.24	2	7.0	.0031		320				
5	14.5		X	.25	1.24	5	5.0	.0078		320				
6	9.25		X	.25	1.24	5	5.0	.0078		320				
7	14.5		X	.25	1.24	5	5.0	.0078		320				
8	9.25		X	.25	1.24	5	5.0	.0078		320				
REMARKS														

Table A-VII, Test Plate, Cutter Data

LEGEND:

a = 0 TAPE COMMAND

b = 3.000 TAPE COMMAND

c = 42.000 TAPE COMMAND

NOTE: POINTS ARE CONNECTED FOR  
ENHANCEMENT OF VISUAL OBSERVATION  
ONLY

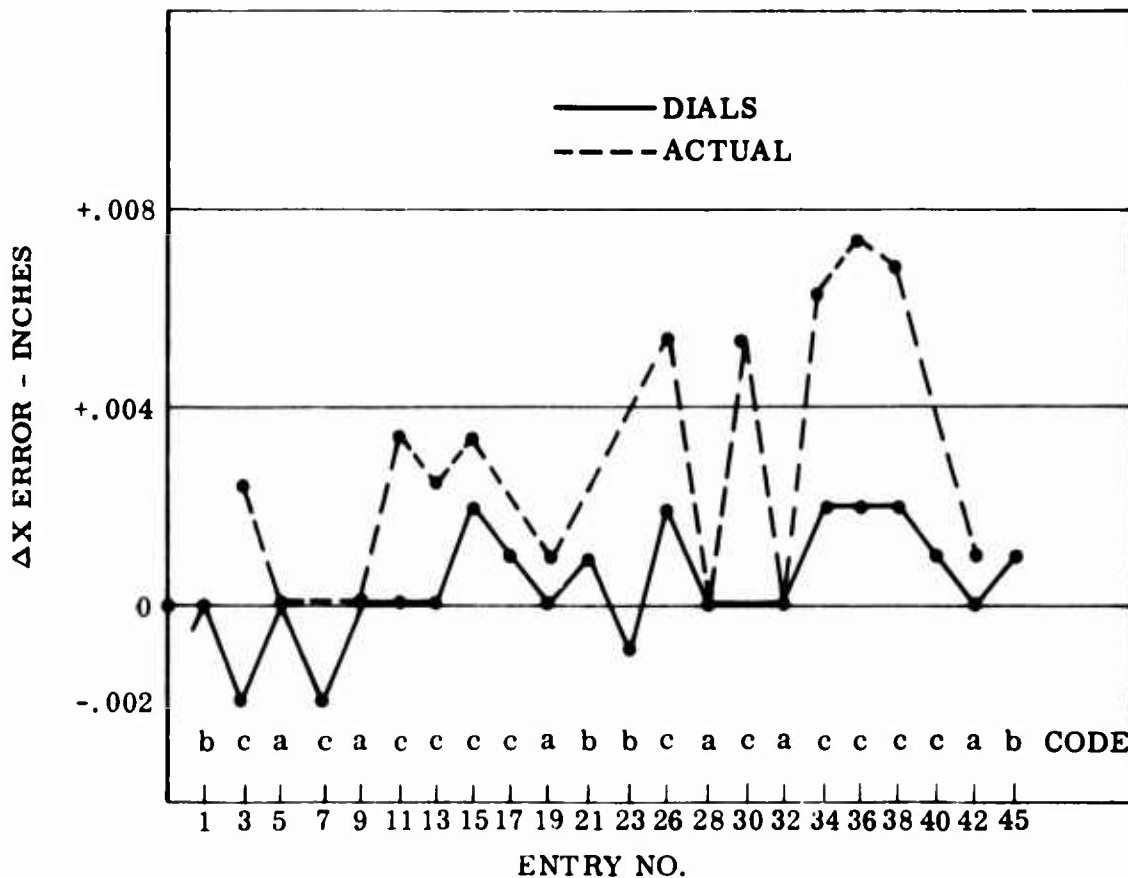

Figure A-7 Morey No. 1, Test Tape No. 2, Positioning Test, X-axis

LEGEND:

a = 0 TAPE COMMAND

b = 3.000 TAPE COMMAND

c = 42.000 TAPE COMMAND

NOTE: POINTS ARE CONNECTED FOR ENHANCEMENT OF VISUAL OBSERVATION ONLY

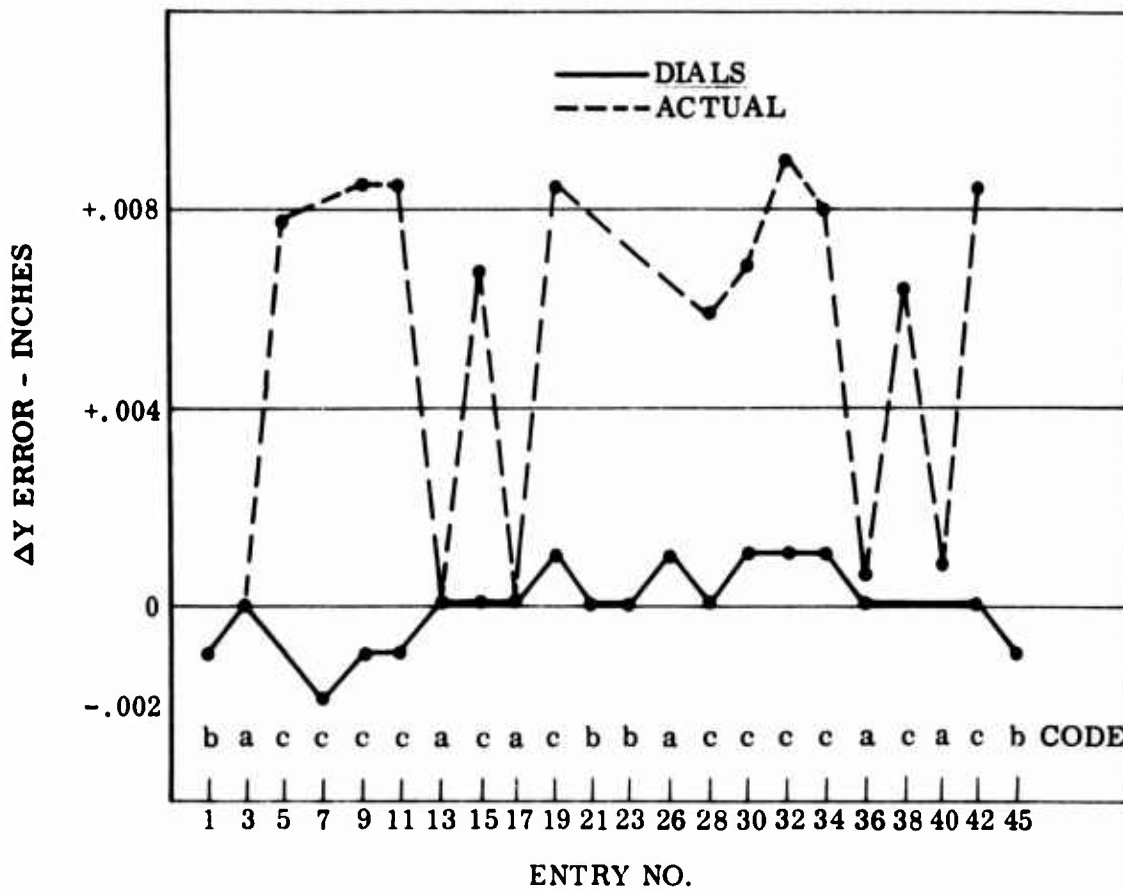

Figure A-8 Morey No. 1, Test Tape No. 2, Positioning Test, Y-axis

LEGEND:

a = 0 TAPE COMMAND

b = 3.000 TAPE COMMAND

c = 42.000 TAPE COMMAND

NOTE: POINTS ARE CONNECTED FOR ENHANCEMENT OF VISUAL OBSERVATION ONLY

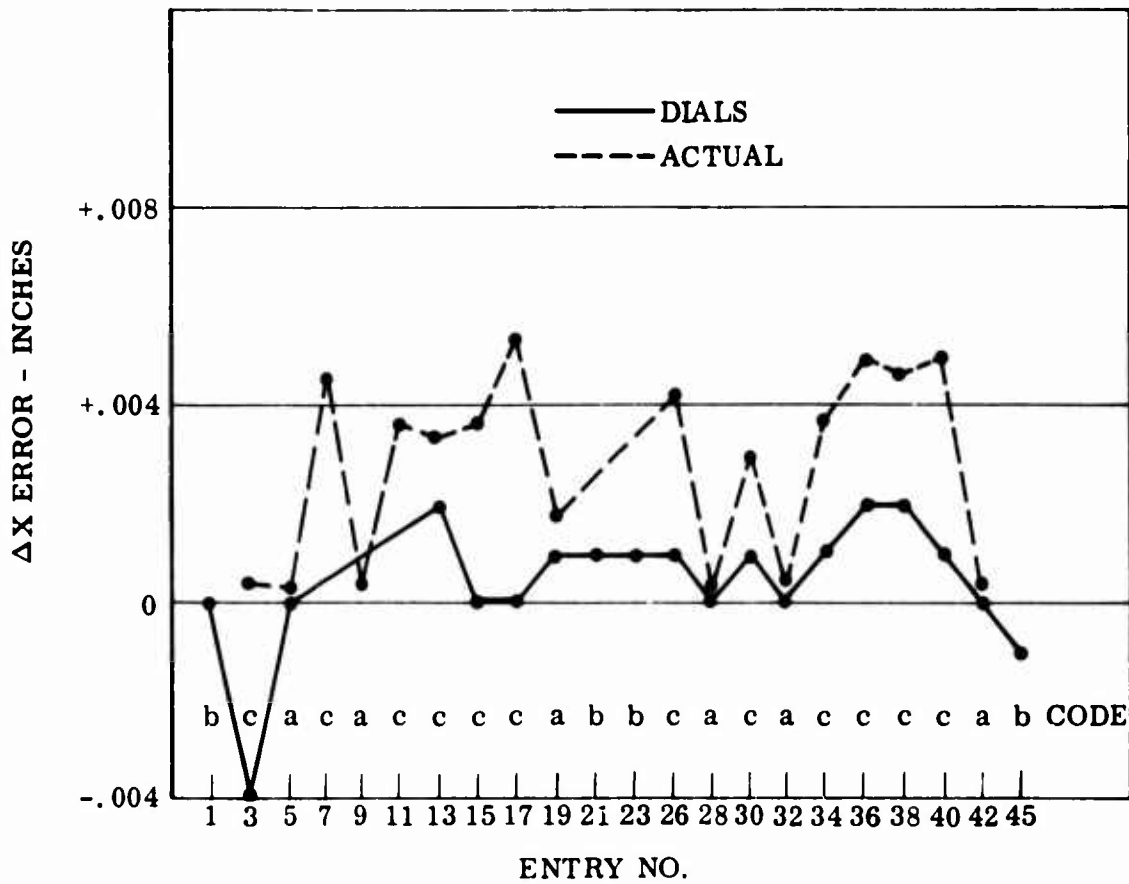

Figure A-9 Morey No. 2, Test Tape No. 2, Positioning Test, X-axis

LEGEND:

a = 0 TAPE COMMAND

b = 3.000 TAPE COMMAND

c = 42.000 TAPE COMMAND

NOTE: POINTS ARE CONNECTED FOR ENHANCEMENT OF VISUAL OBSERVATION ONLY

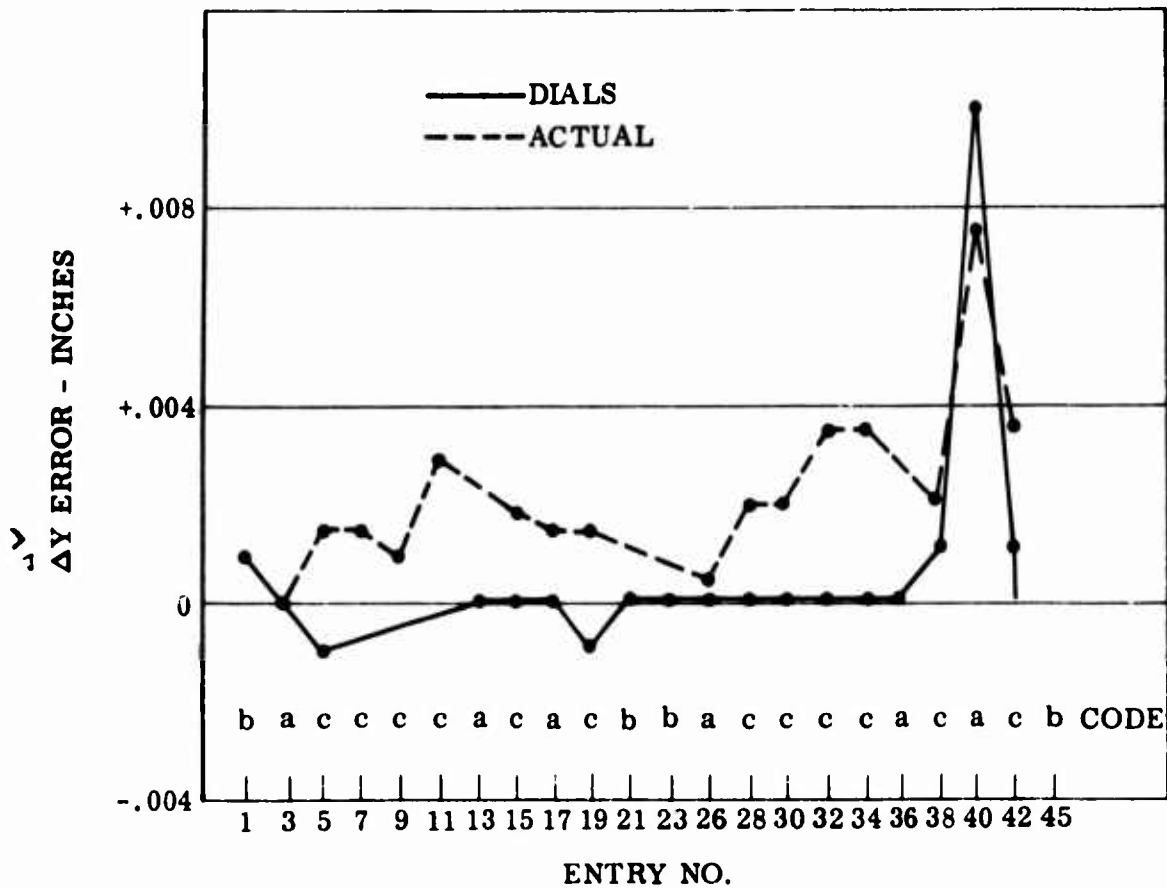
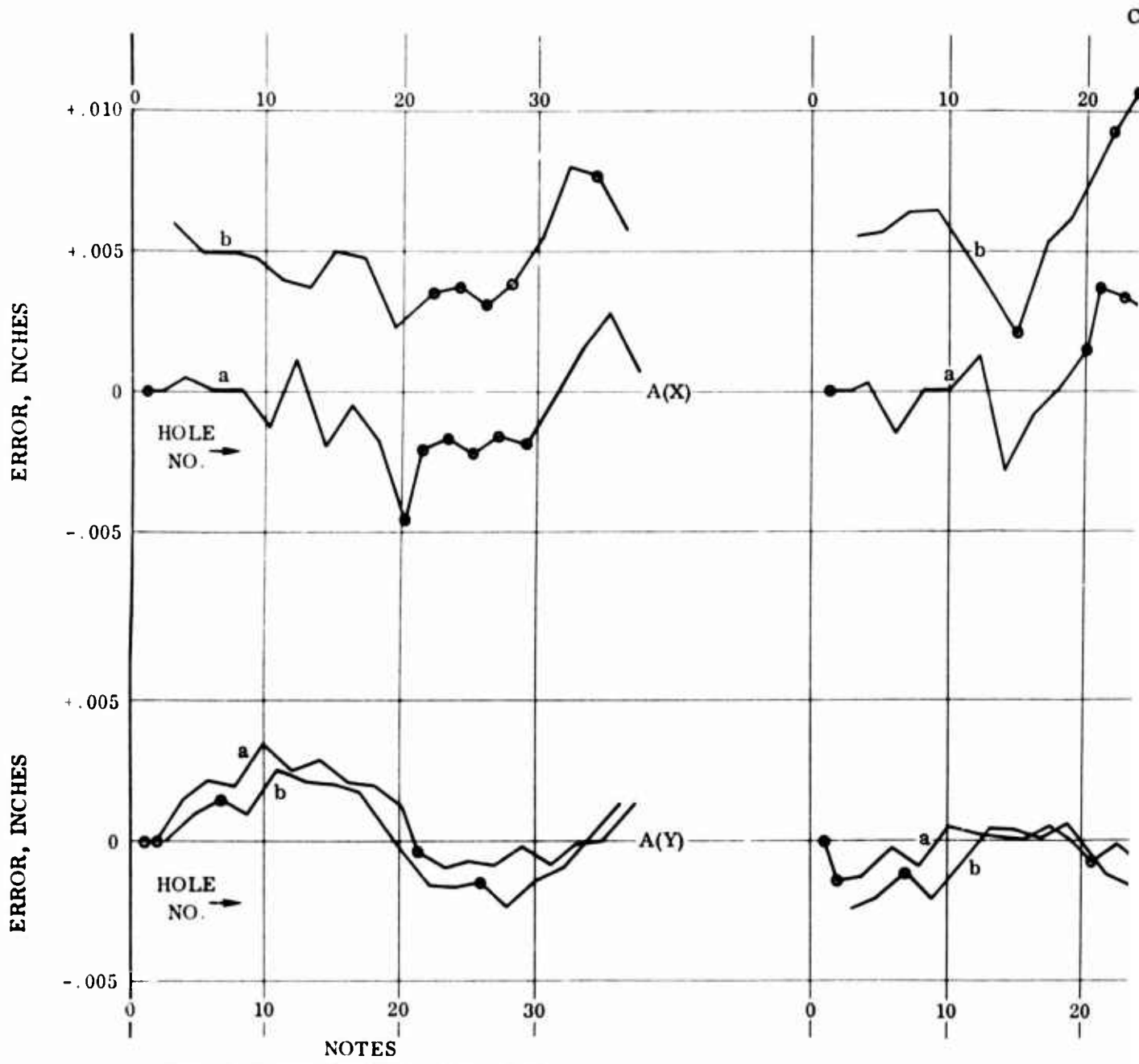

Figure A-10 Morey No. 2, Test Tape No. 2, Positioning Test, Y-axis

**APPENDIX B**

**Data on the McKay Numerically Controlled Drilling and  
Counterboring Machine**



- NOTES
1. Capital letters denote particular plate
  2. Parenthetical letters denote particular axes
  3. Lower case letters denote particular drill head
  4. Deviations shown are plus or minus from reference hole (#1) of individual plate
  5. ○ symbol is special check point hole

il

CONVAIR-SD

RMDA SD-9-5

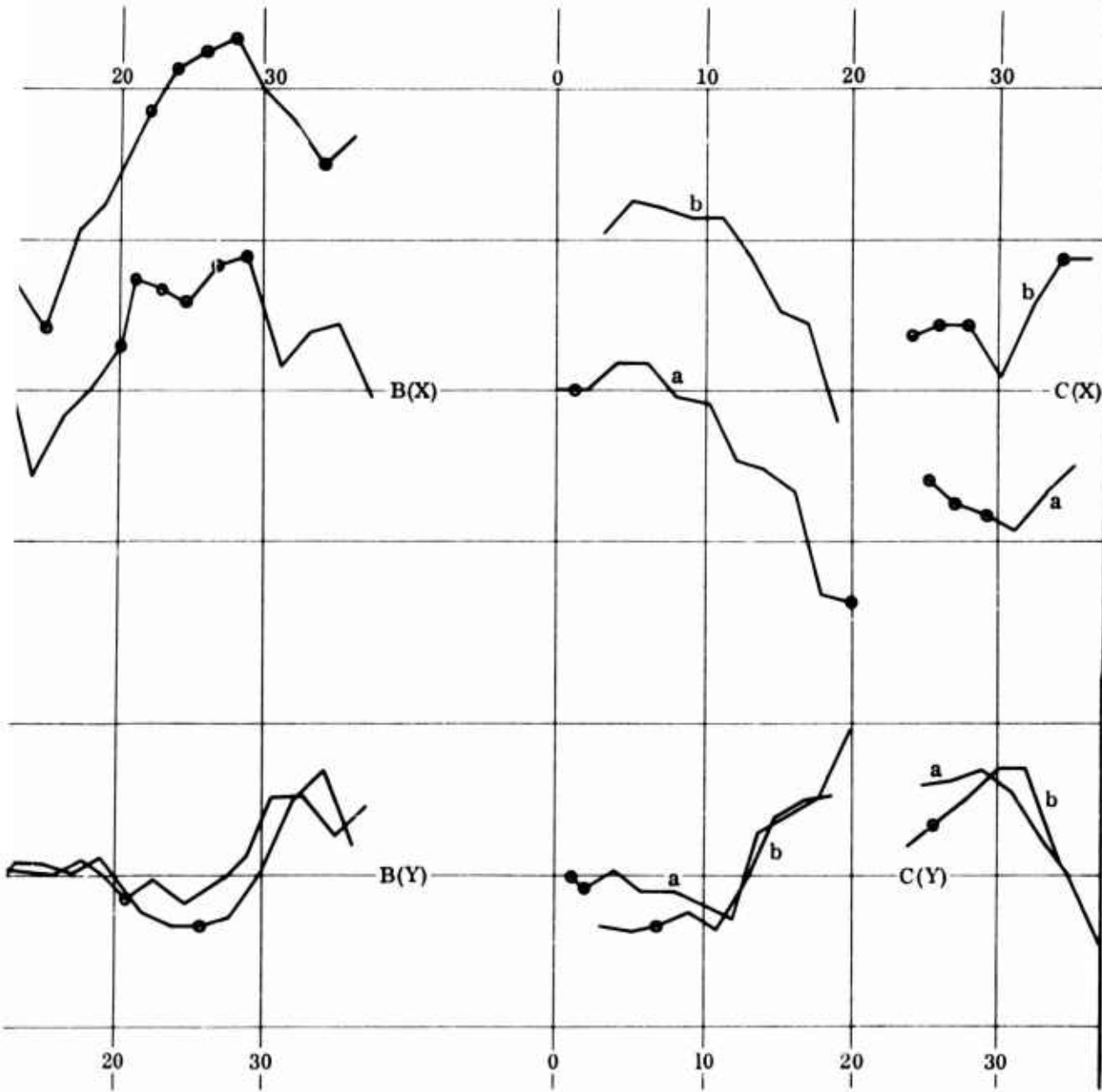
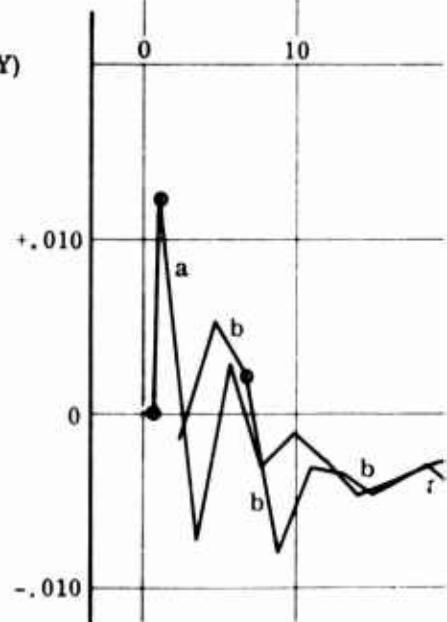
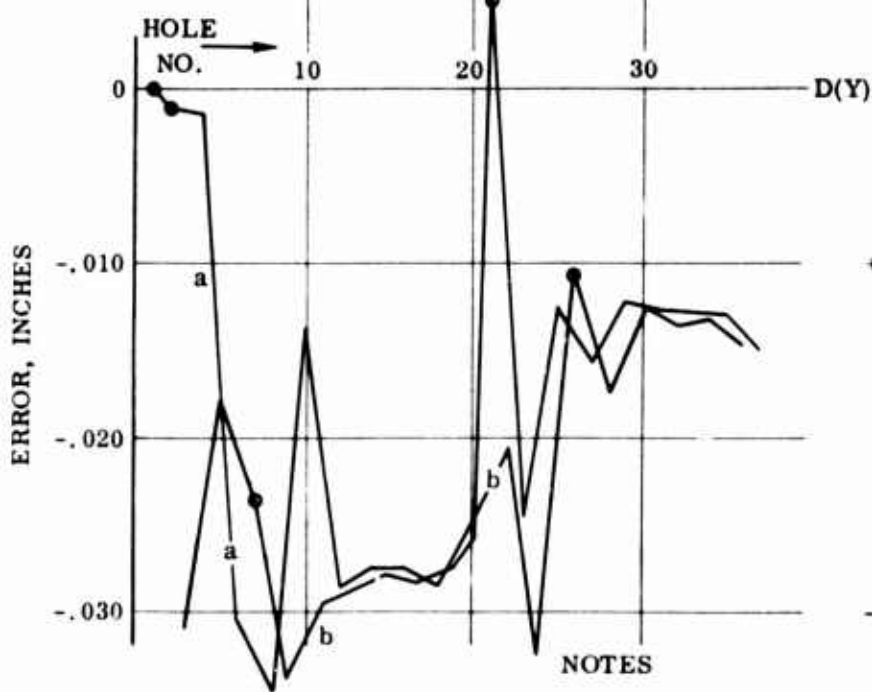
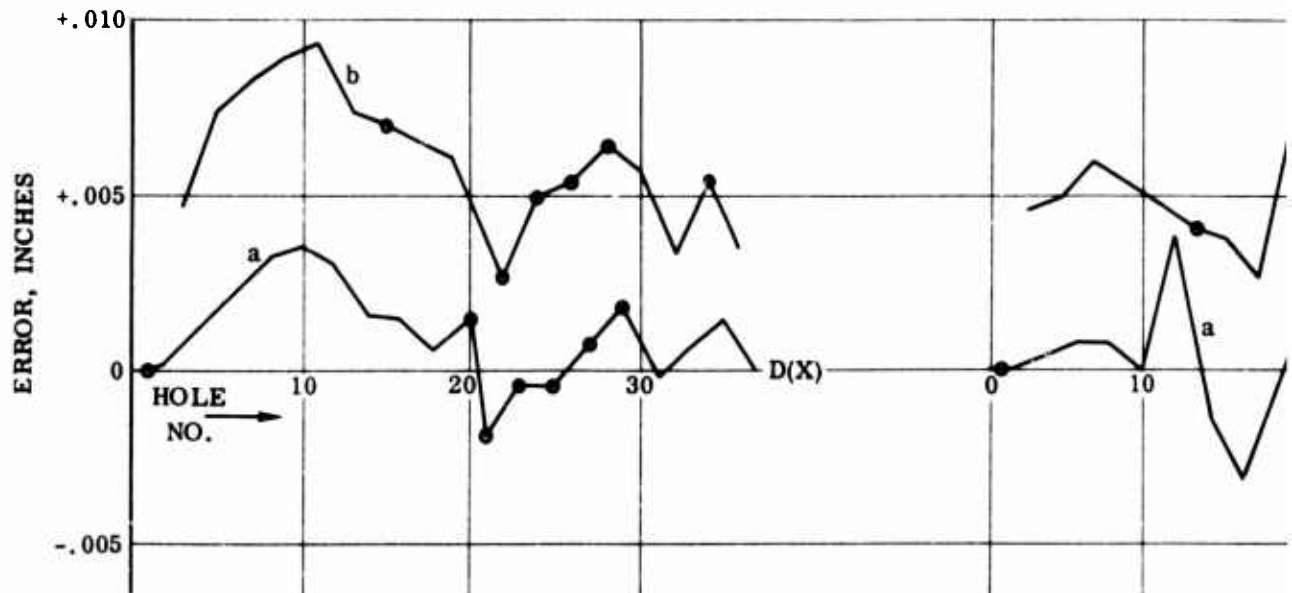
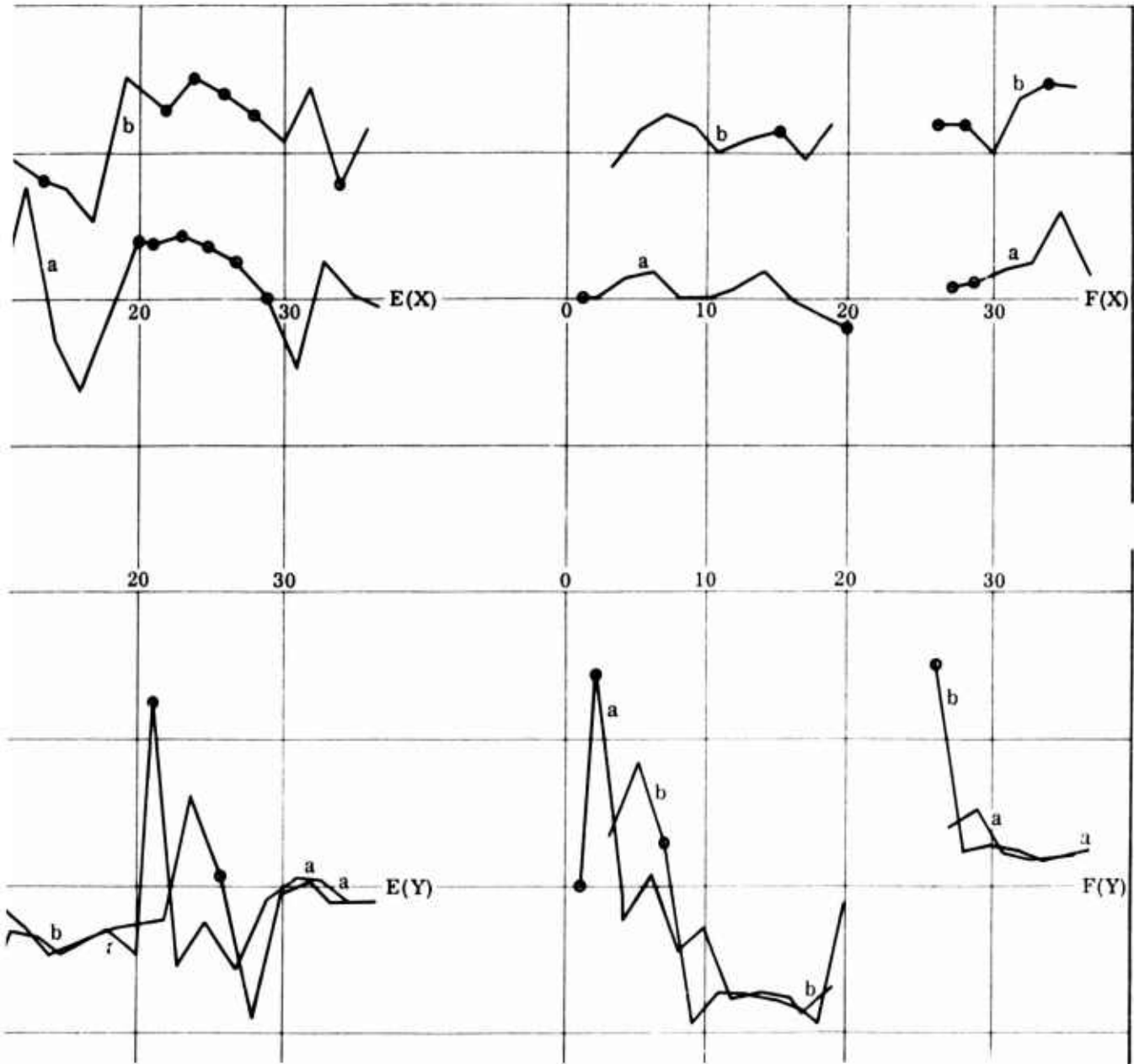

Figure B-1 McKay Test Plates, Deviations, Set III



NOTES

1. Capital letters denote particular plate
2. Parenthetical letters denote particular axes
3. Lower case letters denote particular drill head
4. Deviations shown are plus or minus from reference hole (#1) of individual plate
5. ⊙ symbol is special check point hole



is from  
ate  
role

Figure B-2 McKay Test Plates, Deviations, Set III

**APPENDIX C**

**Proposal to Develop a Numerically Controlled Inspection Machine**

MANUFACTURING DEVELOPMENT AND PROCESS SPECIFICATIONS  
DEPARTMENT 190

NUMERICALLY CONTROLLED INSPECTION  
MACHINE

PROPOSAL BY:

CONVAIR

A Division of General Dynamics Corporation  
San Diego, California

## TABLE OF CONTENTS

<u>PARA</u>		<u>PAGE</u>
1.0	<b>SUMMARY</b>	49
1.1	Program Objective	49
1.2	Benefits from Program	49
1.3	Program Outline	50
1.3.1	Phase I - Study	50
1.3.2	Phase II - Hardware System	52
1.3.3	Phase III - Evaluation and Recommendation	52
1.3.4	Phase IV - Reporting	52
2.0	<b>BACKGROUND INFORMATION</b>	53
2.1	Introduction	53
2.2	The Potential Machine's Capabilities	54
3.0	<b>PROPOSED WORK STATEMENT</b>	57
3.1	Study Phase	57
3.1.1	Proposed Task Force	57
3.1.2	Task Force Make-up	59
3.1.3	Study-method of Approach	59
3.2	The Hardware Phase	64
3.2.1	Establish Specifications	64
3.2.2	Available Hardware and Components	65
3.2.3	Modular Approach Potential	66
3.2.4	User Liaison -- ECS to Convair	66
3.2.5	Acceptance Tests - at Plant and at Installation	66
3.2.6	Installation and Training at User's Plant	67
3.3	Phase III - Evaluation	67
3.4	Phase IV - Reporting	68

## LIST OF ILLUSTRATIONS

<u>FIGURE</u>	<u>TITLE</u>	<u>PAGE</u>
C. 1.	Proposed Schedule	51
C. 2.	A Potential Inspection Machine	55
C. 3.	Inspection Program	56
C. 4.	Read-out Display	58
C. 5.	Sample Questionnaire	61

## 1.0 SUMMARY

### 1.1 Program Objective

First, the principal objective of this proposed program is to develop and test an automatic inspection machine.

Second, the program is aimed at testing the feasibility of applying a developed numerically controlled system to an inspection machine to reduce the unit cost of inspection.

Third, the program is to provide readout that will be useful for quality or reliability determinations by means of statistical analysis.

### 1.2 Benefits from Program

1. This program would provide an optimum process that would allow an accuracy and reliability to inspection hitherto only attainable at great expense or through painstaking care by humans. It would attempt to fulfill many inspection functions needed on a mechanical part in one set-up. It would provide a means of inspection to a calculable tolerance much closer to design allowable than is capable of attainment through human decision at present.
2. The development of the equipment to perform this program would be a significant factor in reduction of production costs in many fields where dimensional reliability is sought.
3. Set-up and work change will be simplified due to two immediately evident factors:
  - a. Pre-program planning.
  - b. Capability of calculating inspection time without prior experience on particular parts.
4. The versatility of the automatic operations is not limited by the shape and size of subject parts. The only limitation envisioned here would be imposed by the control system. However, at this stage it appears that the following can easily be accommodated:

- a. Inside and outside diameters.
  - b. ID and OD on slant or curved surfaces.
  - c. Web thicknesses.
  - d. Bosses, lands, slots, and bores.
  - e. Straight line or contour location.
5. The development of an Automatic Inspection method and equipment would provide the following:
- a. Assumed quality through the use of reliable equipment.
  - b. Rapid inspection of complex parts.
  - c. Establishment of inspection parameters, prior to test, and their recording for programming use.
  - d. Reduced inspection time and cost.
  - e. Reductions in tooling for inspection set-up.
  - f. Rapid re-check of inspection results.
  - g. Means to reduce feed-back loop for reliability data.
  - h. Improved human relations by lessening human fatigue factor.
  - i. Test-bed for universal inspection equipment.

1.3 Program Outline (See Figure C. 1. ).

1.3.1 Phase I - Study (6 months).

A task force from the responsible work forces would evaluate the available data on the subject of automatic inspection. Following this, and in conjunction with the Monitor, a plan for carefully selected plant tours would be formulated.

The assimilation of the data, observations, and part considerations would be used to compile the requirements to be met by the automatic inspection machine. Thus, the foundation could be set up for further applications of this new tool.

	1	2	3	4	5	6	7	8	9	10	11	12	13	14	15	16	17	18	
<b>PHASE I - Survey</b>																			
<b>PHASE II - Hardware System</b>																			
<b>PHASE III - Evaluation and Recommendation</b>																			
<b>PHASE IV - Final Reporting</b>																			

Months after go-ahead

Figure C.1. Proposed Schedule

1.3.2 Phase II - Hardware System (1 year).

The complete establishment of specifications for the Numerically Controlled Inspection Machine would necessarily await completion of the Study Phase. Certain generalities may be stated with the intention of revision as soon as further definitive data is on hand. This approach would be taken toward this phase accomplishment. Once the specifications are finalized, the equipment would be assembled or developed. In the case of the control system, much of the necessary components are already available.

The philosophy of modular design would be employed wherever feasible. The actual production of the machine tool would be let to a competent outside machine tool source once the specs were firmly established.

1.3.3 Phase III - Evaluation and Recommendation (4 months).

Using qualification procedures established from the specifications, the equipment would be qualified at the supplier's plant.

This would be repeated after installation at the user's site. These tests would include, but not be limited to, accuracy, speed, repeatability, reliability, and simulated life tests of electronic components.

Following successful check-out, the equipment would be given a thorough wring-out by actual production inspection use. Parts from other plants may be brought in, through Monitor cognizance, to establish the necessary conclusions to the active study program that triggered off the specifications for the equipment.

1.3.4 Phase IV - Reporting (2 months).

Reports on each phase would be made as they are concluded. In addition, regularly scheduled progress reports would be made to the Monitor. It is assumed that presentation progress

reports could be made as agreed to by the Monitor and the program conductor.

Final reporting would be complete and would contain all conclusions, recommendations, and equipment specifications along with detailed description of the parts inspected and the resultant analysis of the output data.

## 2.0 BACKGROUND INFORMATION

### 2.1 Introduction

The Manufacturing Development Group at Convair has, in previous studies relating to numerically controlled machining, noted the need for new inspection methods. To date, inspection tools are unchanged from those existing prior to any automation of machining facilities. All operations are still performed manually with such inspection equipment while machining capabilities have progressed considerably.

Some special-purpose equipment, such as coordinate measuring machines and optical comparators, have been developed, but these are highly specialized and have a limited application. These are usually special and the ultimate cost must be charged back to the part itself. Like manual inspection, the process remains slow and represents a bottleneck.

An evaluation of existing equipment capabilities, however difficult, is the first course of action to establish any area of improvement. One new method considered is the application of numerical controls themselves to this problem area. With numerically controlled automatic inspection equipment, the emphasis is shifted from the manual operation to the generation of a control tape. Measurements may be made under tape control and results printed-out automatically to highlight any out-of-tolerance condition immediately. Until the fairly recent advent of digital-pulse techniques utilized in Numerical Control, automatic inspection could scarcely be contemplated.

Joint discussions between Convair and potential numerical control system suppliers showed that concurrent studies were being made concerning this problem. These studies, made independently, forecast a promising role for such controls in automatic inspection.

In order to properly assess the problems in numerically controlled inspection, a project was implemented. To save time and money, a decision was reached to check-out this concept utilizing existing numerically

controlled point-positioning equipment. A sub-contractor was selected and subsequent planning conducted to establish a statement of work. As nearly as possible, it was attempted to anticipate closely the eventual fully automatic inspection desired. Time did not allow a complete development program; therefore, the readout was kept manual.

The general scheme established was to select representative parts, inspect these by conventional means, inspect with automatic equipment, and then compare the results. Many other problems became evident as a result of this program, and are considered elsewhere in this proposal.

## 2. 2 The Potential Machine's Capabilities

Figure C. 2. illustrates one practical configuration for the potential inspection machine. The horizontal reference plane is provided by a stable granite surface table, flat to within 0.0005-inch overall. A gantry structure, which carries the carriage on which the measuring probe head is mounted, travels on rails referenced to the surface plate. The gantry moves along the length of the table (X); the carriage moves across the gantry (Y); and the probe head quill moves vertically (Z). In addition, the quill carries a spindle which can be rotated through any prescribed angle ( $\Theta$ ). The measuring probe can be positioned a controllable radius (R) out from the center of the spindle. The probe itself can be easily replaced to allow special probe tips to be inserted when unusual surfaces are to be measured.

All of the parameters, X, Y, Z, R,  $\Theta$ , are controllable from the electronic Control and Display Console stationed beside the inspection table. Either manual or punched-tape control may be used. Display and readout equipment, which presents and records the inspection reading being taken by the machine, is provided on the console.

In operation, the workpiece is mounted in a suitable location on the surface table against locating pins and clamped. For this purpose, the table has been drilled with a series of holes into which precisely located inserts are placed. The inserts can accept either locating pins or clamping bolts. The inserts are located about the table in a grid pattern which permits locating the work in a wide variety of convenient measuring positions. Under numerically controlled operation, an inspection program tape which has been prepared in advance (see Figure C. 3.) is loaded into the reader in the electronics console. The sequentially read instructions position the probe of the inspection machine against various points

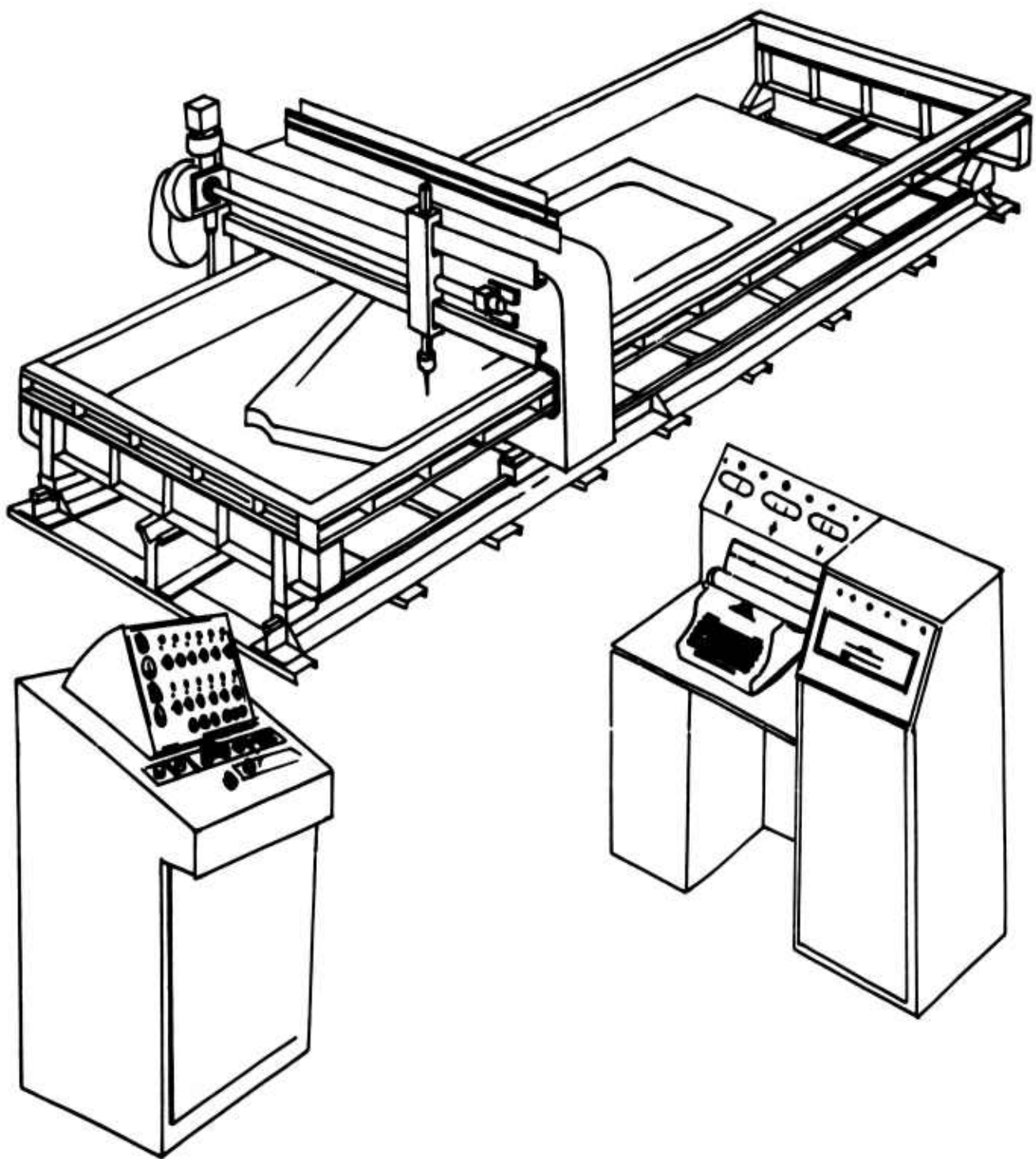

Figure C. 2. A Potential Inspection Machine

Convair Print 62823

Sta.	Θ	X	Y	Z	R	Tolerance		Deviation	
						/	-	/	-
				14.000					
		5.500							
			4.500						
				1.000					
001	←	5.000M				.000	.005		.006
002	→	6.000M							.004
			3.500						
003		M							.002
004	←	5.000M							.007
		5.250							
		5.250							
005	↑		5.000M						.001
006	↓		3.000M						.003
		5.750							
007			M						.003
				3.000					
		4.500							
			5.500						
008	⊙			2.000M		.010	.010		.001
				3.000					
		7.750							
			6.000						
				1.000					
009	○				1.000				C

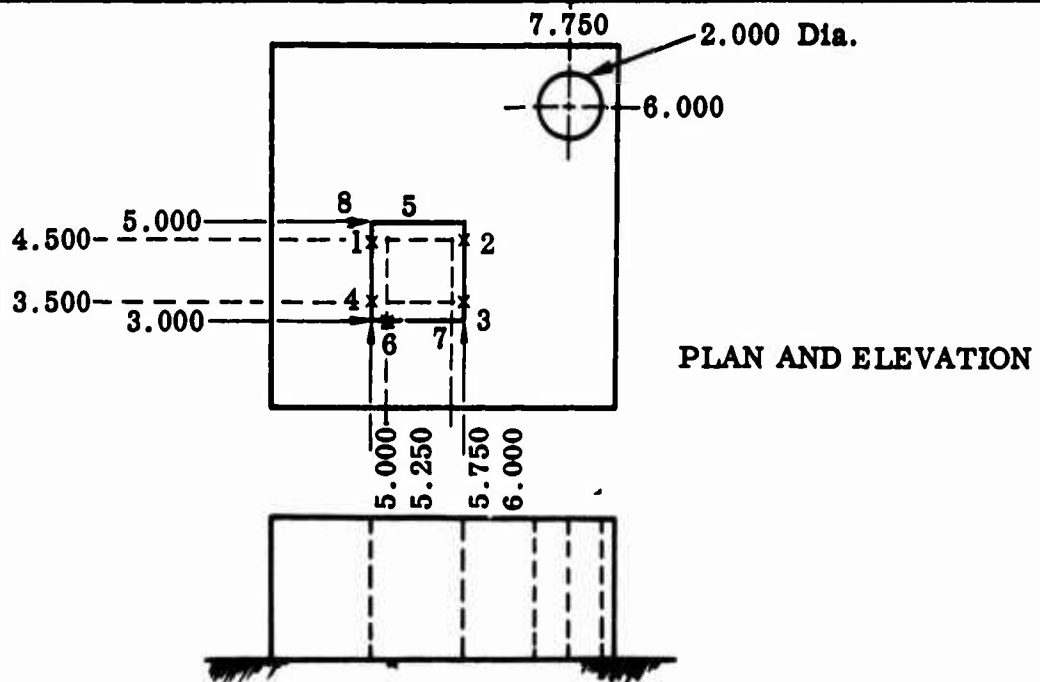

Figure C.3. Inspection Program

to be measured on the surfaces of the workpiece. The command tape identifies the designated location of the point to be measured. The inspection machine measures the actual location. The read-out equipment shows the deviation between the two and whether or not the measurement is in or out of tolerance. Inside and outside flat or curved surfaces, webs, walls, bosses, lands, and slots can be inspected. In addition, due to the extra capabilities provided by the R and  $\Theta$  adjustments, it is also possible to inspect holes. The probe spindle can be positioned to the correct hole-center location, the radius, R, adjusted to the specified hole radius, and the probe tip swept through a revolution (tramming) to show whether the hole is on center, out of round, or slant bored, and by how much (see Figure C.4.).

The read-out equipment may present graphic data, digital tables, or both, depending on the choice of the equipment selected. In addition to printed records, parallel read-out, in the form of encoded punched tape or cards adaptable to direct machine data processing, can be supplied. Using such coded data, statistical quality control analysis can be provided quickly and with little manual labor.

As described, this inspection machine is designed primarily to make mechanical measurements. Our experimental machine showed that in this role alone the potential for saving was as great as that proved possible with numerically controlled metal-cutting machines. However, if desired, the head design will permit the use of other types of measurement transducers, for example, surface-finish pick-ups, X-ray cameras, ultrasonic heads, and the like.

With such equipment, most of the painstaking and tedious work of inspection can be turned over to the machine. The quality control engineer is freed from routine "police" work and is armed with recorded measurement data, two features which can help him attain more quality and reliability at lower cost.

### 3.0 PROPOSED WORK STATEMENT

#### 3.1 Study Phase

##### 3.1.1 Proposed Task Force

It has been Copvair's experience that a task-force approach to handle such programs is the most effective method. It is proposed that this program be handled in the same manner.

New Tolerance Setting

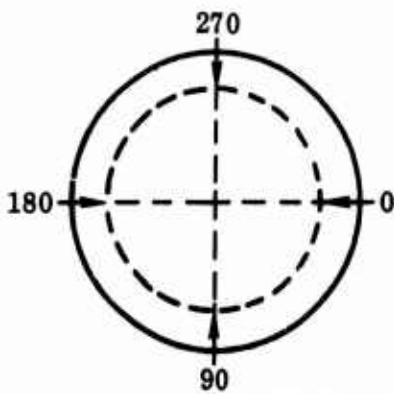
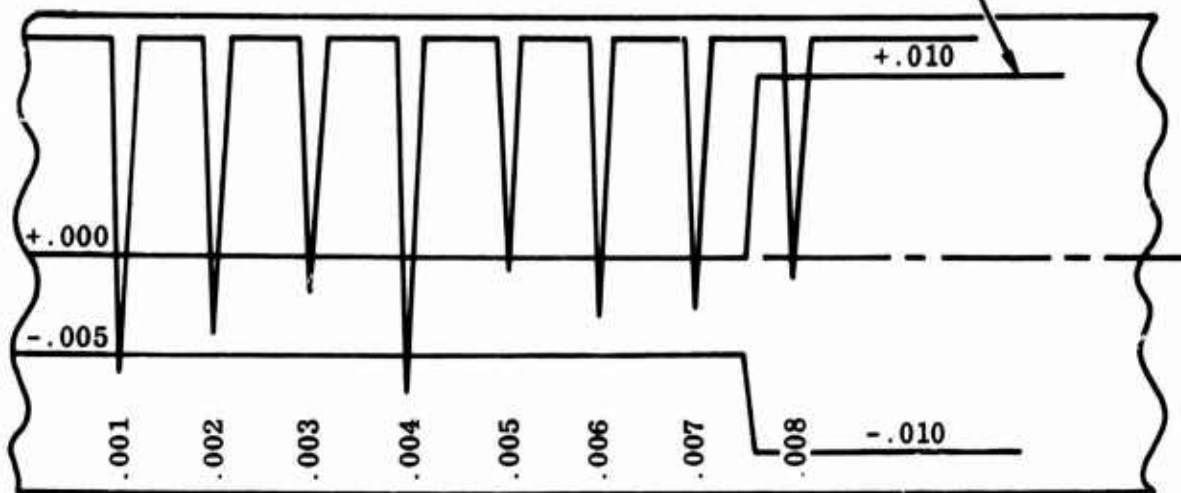

Solid Circle - Designated Hole Position  
Dotted Circle - Actual Hole

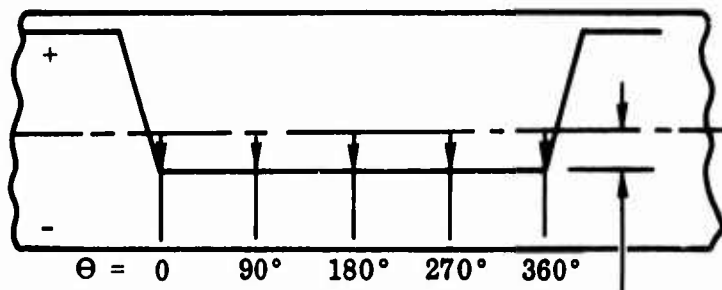

Diameter Error

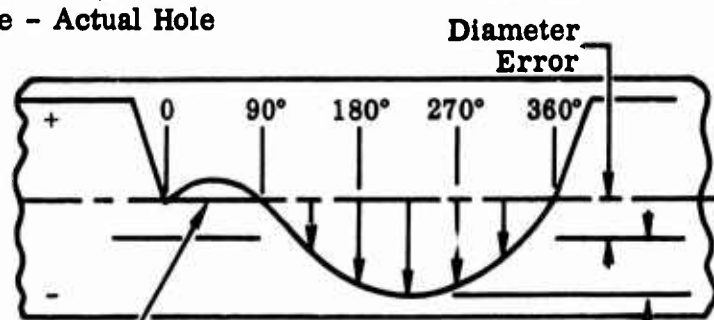
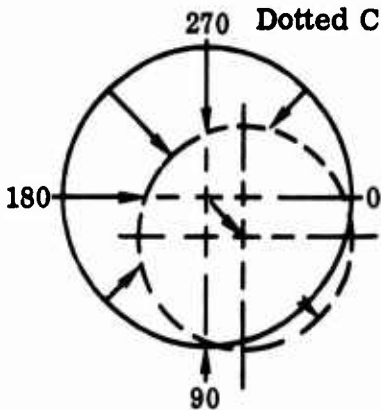

Center Displacement

Angular location of positive peak gives direction of center displacement

Figure C.4, Read-out Display

**3. 1. 2 Task Force Make-up**

The task force for this program will be headed by a Chairman selected from the Monitors in the Manufacturing Development Department at Convair. He will be aided by a Group Leader selected from Quality Control. Other members of this group will be selected, as the need arises, from the system supplier's organization and from other departments affected at Convair.

**3. 1. 3 Study-method of Approach**

1. The team make-up proposed brings a strong combination of talent to bear on the problem. At the same time, however, to ensure efficient working of a mixed group, it will require a tight, well-disciplined task force. To this end, the group structure will be small and simple. It will be led by a permanently appointed chairman aided by a Group Leader. This nucleus will call for aid upon other members of the task force team, as necessary, for special work. The chairman will be totally responsible for conducting the study program.
2. Prior to any field work, the scope of the problem will be clarified and defined. This study is primarily to evaluate the potential for a numerically controlled inspection machine capable of making precise, automatic measurements of a three-dimensional part. Such a machine is capable of more than just dimensional checks. For instance, the positioning head could also carry a surface-finish gage, or an X-ray camera, or an electrical measuring probe. These possibilities will be considered, but as secondary ones only.
3. The study must identify the limits of this machine as well as its capabilities. Some special conditions, for example, small and/or deep holes, may be handled better by separate inspection. Crack detection, material hardness, and surface blemishes are not inspected with this device. The committee will evaluate such factors and restrict the scope of their study accordingly.

4. In order best to evaluate the usefulness of a numerically controlled inspection machine, it is necessary to appreciate, in advance of any shop tours, some of the capabilities of this machine. With this knowledge as a background, it is then possible to pick out the particular areas where improvements will be made, and alternatively, where difficulties may be experienced. It has been our experience, in other studies of this kind, that the best approach to this problem is to go equipped with this background; to observe and ask questions without describing what you have in mind; then point out some of the capabilities of the device being considered and ask for criticism of areas where it is known that decisions remain to be made. The preliminary work that Convair/ECS has done has highlighted the areas where more information is needed. All members of the study group will be briefed on this experience and also will be brought up-to-date on the known capabilities of the inspection machine.
5. One final "tool" which will serve as a guide and memory aid during shop tours is a prepared questionnaire which identifies the observations to be made and the questions to be asked. Better response comes when the form itself is not used during the questioning; its formulation, however, guides the observer who fills it out later. An example is shown in Figure C. 5.
6. The plants to be visited will be carefully selected as representative of typical inspection problems. Maximum effort will be expended where priorities are highest, e. g. , missile manufacturing. Adequate advance notice will ensure minimum time waste. Following initial group visits by the whole committee, subsequent visits by individual committee members will yield greater "coverage" at less cost for travel and with less work interruption at the plants visited.
7. Following the scheduled tours, the study-group observations will be blended into a final report. This report will specify the requirements to be met by the prototype inspection machine, whose construction is to verify, in actual working conditions, the study group findings. The report will also outline a recommended program for future action in the whole field of automatic inspection.

INFORMATION NEEDED	QUESTION	OBSERVE	COMMENTS
<b>TECHNICAL DATA</b>			
1. <u>Size</u>	What size range of parts should machine(s) be able to inspect?	Into what size grouping(s) do the parts inspected fall?	Parts being machined and parts in stock. Sizes of fixtures in stock-room. Size of machines.
2. <u>Flexibility</u>	(a) How many axes must be measured? x, y, z, $\Theta$ , R?	How frequent are angular measurements? Could angular measurements satisfactorily be made by x, y, z measurements?	Observe part shapes. Observe technique of inspecting angles.
(b) What type of surfaces -- square, slant, curved, inside, outside, round, smooth, other?	Ask about general nature of 75% of parts.	Observe parts in process, in stock, in assembly.	
(c) Need for measurement of -- holes, webs, lands, slots, bosses, threads, countersinks, inside and outside radii, diameters, shoulders, tangent or break points.	Ask about frequency of occurrence of these conditions.	Look for these conditions in available parts. Determine pattern occurrence.	
(d) Special awkward inspection conditions. (e.g., deep holes, inside angles and the like)	Ask about special conditions. Ask about frequency of occurrence.	Look for special conditions.	

Figure C.5. Sample Questionnaire

8. This study is recommended, since at this stage in the application of numerical control to inspection, not all the answers are known. Convair's work to date has pointed up many of the areas where more information must be assessed if the best overall long-term results are to be obtained.
9. The comparative inspection data in the initial report showed cost breakeven points at three pieceparts - over 60% savings thereafter. The study also showed that many of today's inspection costs are hidden. This data should be enhanced during the study.
10. Parts to be inspected range widely in size. Certain size groupings are more common than others. Usually, with larger-size parts, the permissible tolerance on dimensions is also larger. The optimum compromise between the size of the inspection machine, its first cost, and required accuracy needs to be established.
11. As pointed out previously, this machine cannot inspect all dimensions on all parts. Undoubtedly, there will be a degree of complexity beyond which it is not practical to go. This feature too requires determination.
12. Various configurations for the machine are possible. Compound table movements and compound gantry movements are two alternate possibilities; various other practical combinations exist. The best one to suit the task may depend upon size. The study will produce recommendations concerning machine configuration and the reasons for the choice.
13. One of the major advantages inherent with a machine of this nature is the automatic presentation of the measurement of the actual part. Various forms for this presentation are possible. The actual coordinates of the measured point may be read-out. Alternatively, the deviation of the measure from truth may be provided. Out-of-tolerance measurements may be highlighted, and the part itself may be marked at such points. The presentation may be displayed and/or recorded in analog (graphic) or digital form. The data may be encoded onto paper tape or cards for subsequent or immediate machine processing.

14. It may be that differing shop inspection and quality control methods will require different types of data read-out, and the machine must be made to adapt to varying requirements. An assessment of this aspect and a recommended approach will come from the study.
15. A point-to-point form of control (as opposed to path or contour control) is recommended for the inspection machine. The program for such controls is a great deal simpler and more direct than the program required for contouring. Also, blueprint information is given in terms of coordinates (or the equivalent), not as contour descriptions. This form of machine matches drawing information, and programming is simple.
16. Point-to-point control systems may be constructed with fixed coordinate reference systems or with the origin of the reference coordinate axes resettable - a "zero set" adjustment. The latter feature adds to machine complexity but simplifies programming. The pros and cons concerning this feature need to be weighed on the scales of requirements and a recommendation made.
17. The measuring finger "probe" of this machine can be designed in various configurations. Special types capable of differential measurements suitable for web measurements, for instance, can be constructed. Alternatively, the machine can be programmed to achieve such measurements with a simple probe. The former will add to machine complexity; the latter will take more time. Frequency of occurrence of such special situations needs to be assessed and reported to aid the machine designer later to make a sensible choice.
18. Other aspects of the automatic inspection problem also need assessment. The need for a precision, numerically controlled, rotary-table accessory; programmable clamping fixtures; automatic handling equipment; special work set-up considerations; new shop procedures; and personnel training considerations are some. The study will bring out others.

19. The study report will provide a thorough evaluation of all these points, give a basis for specifying the best prototype machine, and lay the groundwork for future application of numerically controlled inspection.

3.2 The Hardware Phase

3.2.1 Establish Specifications

The establishment of complete specifications for the numerically controlled inspection machine must naturally await the completion of the foregoing study. However, certain areas may be defined at this time; others may be anticipated with suitable revisions to be made following the complete study.

1. The specifications which can be stipulated now, are:

Temperature-Operating	55° to 105° F
Temperature-Storage	35° to 130° F
Humidity	10 to 98 relative humidity
Pressure	Atmospheric
Vibration and Acceleration	Sufficient to withstand normal shop environment
Dust and Corrosion Resistance	Inspection room atmosphere
Power Requirements	110-220 V, 60 cycle, single-phase

2. The specifications which must be reviewed during the study are shown in the following list. The magnitudes listed under the column headed "Modified 202" indicate those specifications which were met by the equipment constructed by Electronic Control

Systems (ECS), a Division of Stromberg-Carlson, who was selected as system builder for the previously conducted feasibility program. Under the column headed "Proposed" are the corresponding magnitudes which it is felt can be met, and which would fulfill the majority of requirements.

	<u>Modified 202</u>	<u>Proposed</u>
Measurement Accuracy	±0.001 inch	±0.001 inch
Range	14" x 18" x 4"	48" x 144" x 24"
Repeatability	±0.0002 inch	±0.0001 inch
Speed of Traverse	100"/min.	As fast as possible (not less than 100"/min.)
Reading Time	0.4 sec./entry	As fast as possible (not slower than 0.4 sec./entry)
Stability	Some drift with temperature change	Negligible drift over environmental operating range

### 3.2.2 Available Hardware and Components

1. Although numerically controlled automatic inspection constitutes a comparatively new field of endeavor, much of the design consists of application and modification of existing hardware and components. ECS has available standard units of position control which may be used in their present state or with relatively minor modifications.

2. Measuring probes or devices which cover a wide range of applications are available, and it is anticipated that adaptations of such components will adequately satisfy the needs of this equipment.
3. Read-out equipment, in most of the forms suggested earlier, is available as off-the-shelf items. The study will determine the best components to be combined into a system to suit inspection data processing needs.

### 3. 2. 3 Modular Approach Potential

The basic machine will be made as "universal" as is practical. It is not reasonable to assume, however, that a completely universal machine capable of making any type of dimensional measurements would be an economical investment. The design of the basic numerically controlled inspection machine will follow a modular approach, which will allow for extension of its capabilities by the addition or substitution of compatible, unitized accessories.

### 3. 2. 4 User Liaison -- ECS to Convair

As is common with any new development, not all problems can be anticipated in advance. Throughout the design of the subject equipment, it is the intent of ECS to maintain extremely close liaison with the equipment user in order to obtain the best possible solution to all phases of application problems.

### 3. 2. 5 Acceptance Tests - at Plant and at Installation

Acceptance tests will be conducted at the manufacturer's plant, and will be repeated after installation at the user's site. These tests will be drafted by Convair/ECS and submitted with the original prototype design specifications for criticism and approval. These tests will be so designated to prove complete compliance of the equipment with the established specifications, and shall include accuracy, speed, repeatability, reliability, and life tests.

### 3. 2. 6 Installation and Training at User's Plant

The responsibility of ECS in the design and fabrication of the subject equipment will include the installation of the finished machine at the designated site and an adequate training program for the personnel who will subsequently operate the machine.

### 3. 3 Phase III - Evaluation

1. Parts to be selected for inspection shall be picked on the basis of production-quantity requirement and as being representative of more than normal complexity. In all cases, parts shall be applicable, as to size and complexity, to the designed equipment.
2. Conventional inspection data on selected parts shall be assembled in the form of graphs, charts, or tables - whichever is appropriate - to show associated cost, time, equipment and manpower requirements.
3. The Control Program for the selected parts shall be prepared to reflect coordination with conventional inspection results for later evaluation. The program shall also be used to establish the initial numerical control procedures. All programs shall be proofed or verified prior to actual use to ascertain completeness and correctness.
4. Part-holding fixtures shall be designed and fabricated to provide the following:
  - a. Tooling set points and holes
  - b. Coordination of fixtures to machine bed
  - c. Normal tooling material
  - d. Clearance for inspection devices

5. Set-up and inspection of selected parts shall be performed to accomplish the following intent:
  - a. Perform necessary replications to compile statistical data on each part.
  - b. Collect all other pertinent data to operation outside of information already programmed.
6. Readout from the inspection operation shall be evaluated for at least, but not limited to, the following aspects:
  - a. Comparison with input data.
  - b. Charted variables.
  - c. Listed defects, if found.
  - d. Report on any of the above, if necessary, without having to rerun parts on equipment.
7. Prepare economic evaluation of results in preparation for final reporting on program.
8. Prepare resultant recommendations and procedures for most effective utilization of equipment considering the results from all parts inspected.

#### 3.4 Phase IV - Reporting

Prepare final report to include results from all phases of work.

1. Each phase shall be reported separately as completed.
2. Final report shall include summaries of previous phase reports and shall include conclusions and recommendations covering all phases of work performed.
3. Presentation reports would be made at a frequency agreed to between the Monitor and Convair.