

# DESIGN, DEVELOPMENT AND FLIGHT TESTS OF CHEMICAL RELEASE PAYLOADS FOR UPPER ATMOSPHERE RESEARCH

Edward F. Allen, Jr.

SPACE DATA CORPORATION  
1331 South 26th Street  
Phoenix, Arizona 85034

CONTRACT NO. AF 19(628) 5125

Project No. 7635, 000D, 8688  
Task No. 763508, 000D49, 000D75  
Work Unit No. 76350801, 000D0001

## FINAL REPORT

Period Covered 1 July 1965 - 31 August 1968

30 September 1968

Distribution of this document is unlimited. It may be released to the Clearinghouse, Department of Commerce, for sale to the general public.

CONTRACT MONITOR: William K. Vickery  
Aeronomy Laboratory

Prepared For

Air Force Cambridge Research Laboratories  
Office of Aerospace Research  
United States Air Force  
Bedford, Massachusetts 01730

DDC  
RECEIVED  
FEB 7 1969  
RECEIVED

LB B

This research was partially supported by the Air-Force In-House Laboratory Independent Research Fund; also in part, by the Advanced Research Projects Agency under ARPA Order No. 1141

Reproduced by the  
CLEARINGHOUSE  
for Federal Scientific & Technical  
Information Springfield Va. 22151

AD 681833

**DESIGN, DEVELOPMENT AND FLIGHT TESTS OF  
CHEMICAL RELEASE PAYLOADS FOR  
UPPER ATMOSPHERE RESEARCH**

**Edward F. Allen, Jr.**

**SPACE DATA CORPORATION  
1331 South 26th Street  
Phoenix, Arizona 85034**

**CONTRACT NO. AF 19(628) 5125**

**Project No. 7635, 000D, 8688  
Task No. 763508, 000D49, 000D75  
Work Unit No. 76350801, 000D0001**

**FINAL REPORT**

**Period Covered 1 July 1965 - 31 August 1968**

**30 September 1968**

**Distribution of this document is unlimited. It may be released to the  
Clearinghouse, Department of Commerce, for sale to the general public.**

**CONTRACT MONITOR: William K. Vickery  
Aeronomy Laboratory**

**Prepared For**

**Air Force Cambridge Research Laboratories  
Office of Aerospace Research  
United States Air Force  
Bedford, Massachusetts 01730**

**This research was partially supported by the Air-Force In-House Laboratory Independent Research Fund;  
also in part, by the Advanced Research Projects Agency under ARPA Order No. 1141**

## FOREWORD

**This research was partially supported by the Air Force In-House Laboratory Independent Research Fund; also in part, by the Advanced Research Projects Agency.**

## ABSTRACT

Rocket borne chemical payload systems were designed, developed and flight tested to give controlled releases of gases, liquids and solids. Payloads consisted of chemical tanks, chemicals, fluid controls with associated plumbing, event programmer and aerodynamic envelope.

Trimethylaluminum, Diborane, Nitric Oxide, High Explosives seeded with metals, Barium/Copper Oxide and Cesium Nitrate, Aluminum/Tungsten systems were provided.

Chemical handling techniques were developed and engineering field services were provided to assist with payload launches.

**BLANK PAGE**

## TABLE OF CONTENTS

|         |   |    |
|---------|---|----|
| 1.      | INTRODUCTION.....   | 1  |
| 2.      | PAYLOAD SUMMARY .....   | 2  |
| 2.1     | General .....   | 2  |
| 2.2     | Nitric Oxide Trail (277-10) .....                               | 2  |
| 2.3     | Diborane Trail (349-10) .....                                   | 4  |
| 2.4     | TMA Trail (Accumulator Tank) (308-11) .....                     | 5  |
| 2.5     | TMA Trail (Baffled Tank) (299-11) .....                         | 6  |
| 2.6     | TMA - Four "Point" (312-11) .....                               | 7  |
| 2.7     | TMA Intermittent Release Payload .....                          | 8  |
| 2.8     | High Explosive Payload (278-11) .....                           | 9  |
| 2.9     | Barium - Three Burner Payload (309-12) .....                    | 10 |
| 2.10    | Barium Modules (319-11 and 333-11) .....                        | 11 |
| 2.11    | Barium - Delayed Release (Large Void) (351-10 and 363-10) ..... | 14 |
| 2.12    | Cesium Nitrate/Aluminum/Tungsten (362-10) .....                 | 17 |
| 3.      | SUBSYSTEMS .....  | 18 |
| 3.1     | General .....   | 18 |
| 3.2     | Fluid Controls .....  | 18 |
| 3.2.1   | General .....   | 18 |
| 3.2.2   | Fittings .....  | 18 |
| 3.2.3   | Squib Valve (273-10) .....                                      | 19 |
| 3.2.4   | Intermittent Release Systems .....                              | 21 |
| 3.2.4.1 | General .....   | 21 |
| 3.2.4.2 | Cam Operated Toggle Valve (284-11,<br>284-12) .....             | 21 |
| 3.2.4.3 | Geneva Mechanism Actuated Ball Valve<br>(289-13) .....          | 22 |
| 3.2.4.4 | Solenoid Actuated Valves (322-11,<br>371-10) .....              | 22 |

|         |   |    |
|---------|---|----|
| 3.2.5   | Nozzles .....                             | 26 |
| 3.2.5.1 | General .....                             | 26 |
| 3.2.5.2 | Metering Orifice .....                    | 26 |
| 3.2.5.3 | Atomizing Nozzles .....                   | 26 |
| 3.2.5.4 | Rupture Disc Nozzle .....                 | 26 |
| 3.2.6   | Accumulators - Cold Gas and Hot Gas ..... | 33 |
| 3.3     | Tanks .....                               | 34 |
| 3.3.1   | General .....                             | 34 |
| 3.3.2   | Structural Design .....                   | 34 |
| 3.3.3   | Material .....                            | 35 |
| 3.3.4   | Joints .....                              | 37 |
| 3.3.5   | Seals .....                               | 37 |
| 3.4     | Programmings .....                        | 40 |
| 3.4.1   | General .....                             | 40 |
| 3.4.2   | Single Event .....                        | 40 |
| 3.4.3   | Multi-Event .....                         | 43 |
| 3.4.4   | Multi-Event with Valve Sequencer .....    | 46 |
| 3.4.5   | Lid Separation Device .....               | 51 |
| 3.4.6   | Pyro-delay .....                          | 53 |
| 3.5     | Barium Burner .....                       | 53 |
| 3.5.1   | General .....                             | 53 |
| 3.5.2   | Burner Hardware .....                     | 55 |
| 3.5.3   | Chemicals .....                           | 57 |
| 3.5.4   | Tests .....                               | 57 |
| 3.5.4.1 | Structural Tests (Nozzles and Tank) ..... | 57 |
| 3.5.4.2 | Energy .....                              | 57 |
| 3.5.4.3 | Pressure .....                            | 57 |
| 3.5.4.4 | Vent Time .....                           | 60 |
| 3.5.4.5 | Flame Temperature .....                   | 60 |
| 3.5.4.6 | Burn time .....                           | 60 |
| 3.5.4.7 | Thrust .....                              | 60 |
| 3.5.4.8 | Lid Separation .....                      | 62 |

|       |   |    |
|-------|---|----|
| 3.6   | Cesium Nitrate/Aluminum/Tungsten Burner (Ion Generator) . . . . . | 62 |
| 3.6.1 | General . . . . .   | 62 |
| 3.6.2 | Tests . . . . .   | 64 |
| 4.    | CHEMICAL HANDLING . . . . .                                       | 65 |
| 4.1   | General . . . . .   | 65 |
| 4.2   | Nitric Oxide . . . . .  | 67 |
| 4.3   | Diborane . . . . .  | 70 |
| 4.4   | TMA . . . . .   | 74 |
| 4.5   | High Explosives (TNT and RDX) . . . . .                           | 76 |
| 4.6   | Barium/Copper Oxide . . . . .                                     | 77 |
| 4.7   | Cesium Nitrate/Aluminum/Tungsten Compounds . . . . .              | 80 |
| 4.8   | Gas Generators . . . . .  | 81 |
| 5.    | REFERENCES . . . . .  | 87 |
| 6.    | PARTS LIST . . . . .  | 83 |

## LIST OF FIGURES

|     |  |    |
|-----|--|----|
| 1.  | Nitric Oxide Payload (277-11) Functional Sketch . . . . .  | 3  |
| 2.  | Diborane Payload (349-10) Functional Sketch . . . . .  | 4  |
| 3.  | TMA Trail Module (Accumulator Tank) (308-11) Functional Sketch . . . . .                                   | 5  |
| 4.  | TMA Trail Module (Baffled Tank) (299-11) Functional Sketch . . . . .                                       | 6  |
| 5.  | TMA - Four "Point" Payload (312-11) . . . . .  | 7  |
| 6.  | TMA - Intermittent Release Payload (Solenoid Valve - 371-10) . . . . .                                     | 8  |
| 7.  | High Explosive Payload (278-11) . . . . .  | 9  |
| 8.  | Barium Three Burner Payload (309-12) . . . . .   | 10 |
| 9.  | Barium Three Module Payload (319-12) . . . . .   | 12 |
| 10. | Barium Three Module Payload (333-12) . . . . .   | 13 |
| 11. | Barium Delayed Release (Large Void) Payload (351-10) . . . . .   | 15 |
| 12. | Barium Delayed Release (Large Void) Payload (363-10) . . . . .   | 16 |
| 13. | Cesium Nitrate/Aluminum/Tungsten Payload (362-10) . . . . .  | 17 |
| 14. | Squib Valve (273-10) . . . . .   | 20 |
| 15. | Cam Operated Toggle Valve (284-11) . . . . .   | 23 |
| 16. | Geneva Mechanism Operated Ball Valve (284-13) . . . . .  | 24 |
| 17. | Intermittent Release System Solenoid Actuated Valve(s) Functional Sketch,<br>(322-11 and 371-10) . . . . . | 25 |
| 18. | Nozzle Types . . . . .   | 27 |
| 19. | Average Release Rate vs Orifice Diameter . . . . .   | 28 |

|     |   |    |
|-----|---|----|
| 20. | Particle Size vs Nozzle Number - Hollow Cone Nozzle . . . . .                           | 30 |
| 21. | Particle Size vs Spraying Pressure - Hollow Cone Nozzle . . . . .                       | 30 |
| 22. | Particle Size vs Nozzle Orifice Diameter - Hollow Cone Nozzle (TN) . . .                | 31 |
| 23. | Flow Rate vs Liquid Pressure for Hollow Cone Nozzles (LN) . . . . .                     | 32 |
| 24. | Tank Joints and Seals . . . . .   | 38 |
| 25. | Allowable Force per Thread vs Working Pressure, Aluminum Tank (277-43) .                | 39 |
| 26. | Electrical Schematic (277-44) Single Event Programmer - Single EED . . . .              | 41 |
| 27. | Electrical Schematic (278-35) Single Event Programmer - Dual EED . . . . .              | 42 |
| 28. | Electrical Schematic (309-28) Three Event Programmer . . . . .                          | 44 |
| 29. | Electrical Schematic (378-34) Three Event Programmer . . . . .                          | 45 |
| 30. | Electrical Schematic (284-214) Three Event Programmer with Valve<br>Sequencer . . . . . | 47 |
| 31. | Electrical Schematic (371-23) Multi-event Programmer with Valve<br>Sequencer . . . . .  | 48 |
| 32. | Electrical Schematic (372-21) Valve Sequencer . . . . .                                 | 49 |
| 33. | Typical Pulse Profile - Valve Sequencer . . . . .                                       | 50 |
| 34. | Electrical Schematic (363-27) Lid Separation Device . . . . .                           | 52 |
| 35. | Barium Burner Configuration Sketches . . . . .  | 54 |
| 36. | Separation System - Barium Burner . . . . .   | 56 |
| 37. | Barium Burner Thrust Test Set Up (Test 319-3) . . . . .                                 | 61 |
| 38. | Cesium Nitrate/Aluminum/Tungsten Burner (363-10) . . . . .                              | 63 |
| 39. | Nitric Oxide Loading System . . . . .   | 68 |

|     |  |    |
|-----|--|----|
| 40. | Nitric Oxide Loading Density vs Pressure . . . . . | 69 |
| 41. | Diborane Vapor Pressure vs Temperature . . . . .   | 71 |
| 42. | Diborane Loading System . . . . .                  | 72 |
| 43. | TMA Loading System . . . . .                       | 75 |
| 44. | Barium/Copper Oxide Preparation . . . . .          | 78 |

## LIST OF TABLES

|    |  |    |
|----|--|----|
| 1. | Comparative Particle Size Data . . . . .                         | 29 |
| 2. | Tank Summary . . . . .   | 36 |
| 3. | Barlum Burner Chemical Formulations . . . . .                    | 58 |
| 4. | Barlum Burner Pressure Test Summary . . . . .                    | 59 |
| 5. | Chemical Properties, Handling, Precautions and Hazards . . . . . | 66 |
| 6. | Diborane Storage Stability . . . . .                             | 73 |

## LIST OF APPENDIXES

- A. Payload Design and Test Criteria
- B. Nitric Oxide Payload Tests (Reference TM 225)
- C. Squib Valve (273-10) Tests
- D. Toggle and Geneva Valve Tests (Reference TM 105)
- E. Tank Design Equations
- F. Barium Burner Nozzle Tests (Reference TM 193)
- G. Barium Burner Calorimeter Tests (Reference TM 255)
- H. Barium Burner Tabulated Test Results (Reference TM 193)
- I. Barium Burner Pressure Traces
- J. Cesium Nitrate/Aluminium/Tungsten Burner Tests

## 1. INTRODUCTION

This report documents the work conducted by Space Data Corporation under AFCL Contract Number AF19(628)-5125 from July 1965 through June 1968.

The objective of this program was to provide payload systems, design, development, fabrication and flight test for rocket borne payloads carrying liquids, gases and solids into the upper atmosphere.

Seven launch test programs were supported during this period. Forty-four payload systems were delivered and launched. Test programs were conducted from Eglin AFB, Florida, Wallops Island, Virginia and Vega Baja, Puerto Rico.

Standardization of subsystems was emphasized where possible: Tankage was either low pressure, (to 300 PSI) for liquids or high pressure for gases ( to 3000 PSI); programmers were either single event, multiple event or multiple event with a pulse generator; fluid controls included squib valves to initiate flow, and intermittent liquid release systems to interrupt flow, nozzles for metering flow and atomizing liquids.

Chemical formulations and release requirements were specified by AFCL.

Chemical handling techniques were developed; ground safety procedures were prepared and engineering field services were provided for the seven flight test programs conducted during this period.

This report describes the payload systems, gives design information; test results and chemical handling procedures.

**BLANK PAGE**

## 2. PAYLOAD SUMMARY

### 2.1 General.

Standardization of payload subsystems was emphasized where possible. Systems may be classified into three categories; (1) complete payload systems, (2) payload modules which may be flown independently or in conjunction with other modules on the same vehicle and (3) subsystems, including fluid controls, tanks and programmers.

Payloads were designed to withstand the flight environments described in Appendix A. Joints between nose cones, modules, payloads and rockets (except Arcas) were slip fit with (24 each 1/4 x 28 high strength) radial screws.

The following paragraphs briefly describe these payloads and modules; whereas subsystems are described in Section 3.

### 2.2 Nitric Oxide Trail Payload (227-11).

Twenty pounds of Nitric Oxide (loaded at 3000 PSI) were released at a constant rate of approximately 200 grams/second to produce a continuous trail over approximately a 50 second time duration. The tank (277-43) was constructed of aluminum with threaded joints; A single event programmer opened a squib valve initiating release through a pressure regulator valve; through interconnecting plumbing and a metering nozzle located in the nose tip.

Telemetry was used to measure tank temperature and pressure for flow calculations.

Figure 1 is a functional sketch of this payload. Development tests are detailed in Appendix B.

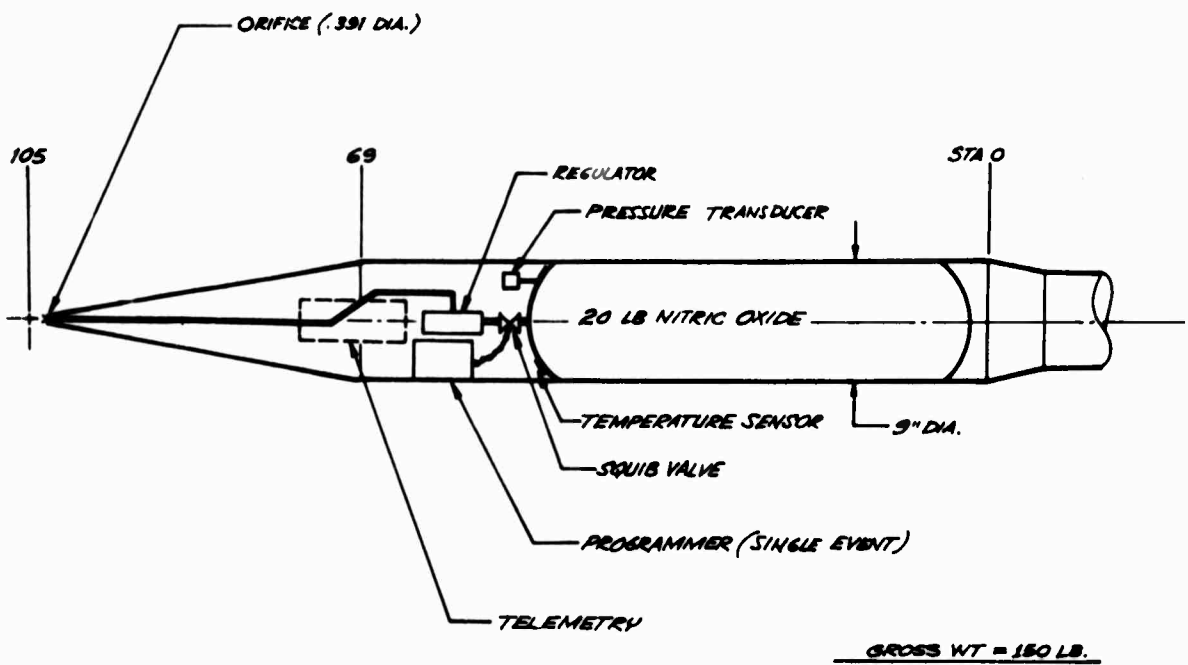

FIGURE 1 NITRIC OXIDE PAYLOAD 277-11

### 2.3 Diborane Trail Payload (349-10).

Approximately 4 pounds of gaseous Diborane was released as a continuous trail. A single event programmer opened a squib valve initiating release through a metering nozzle located in the nose tip. The Diborane was carried in an integral welded stainless steel tank (349-22) at approximately 500 PSI with a 0.0038 pound/cubic inch loading density.

Figure 2 is a functional sketch of this payload.

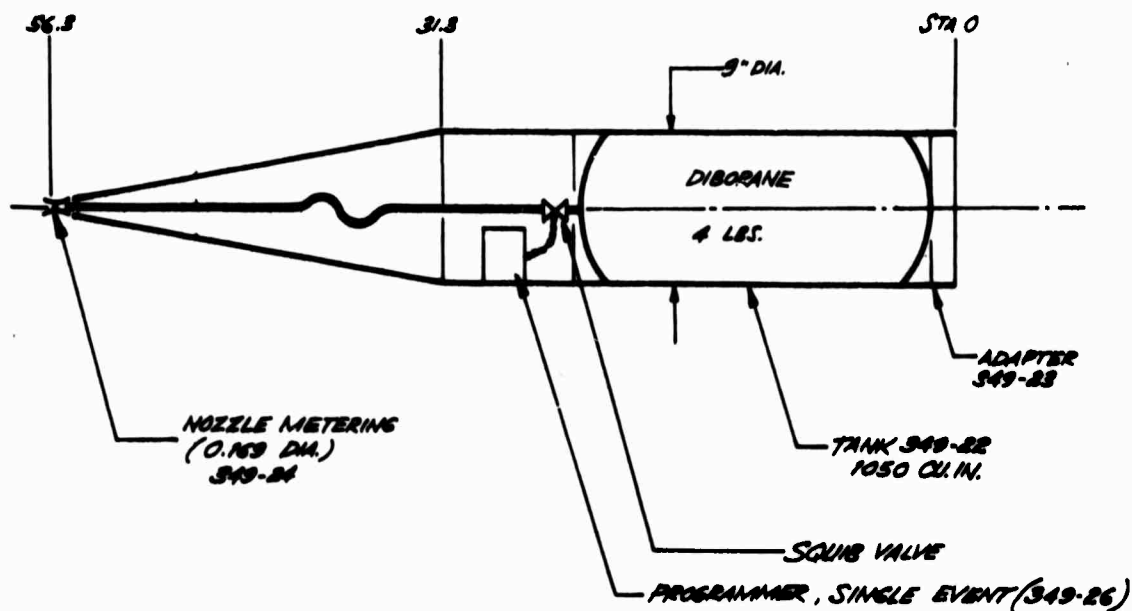

FIGURE 2 DIBORANE PAYLOAD (349-10)

## 2.4 TMA Trail Module (Accumulator Tank) (308-11).

Approximately 40 pounds of TMA were released as a continuous trail at desired release rates. A single event programmer opened a squib valve allowing TMA to flow through two metering nozzles. The tank was aluminum with bolted joints and contained a piston forming an accumulator that separated the liquid from the gas to insure a continuous liquid release.

Figure 3 is a functional sketch of this payload.

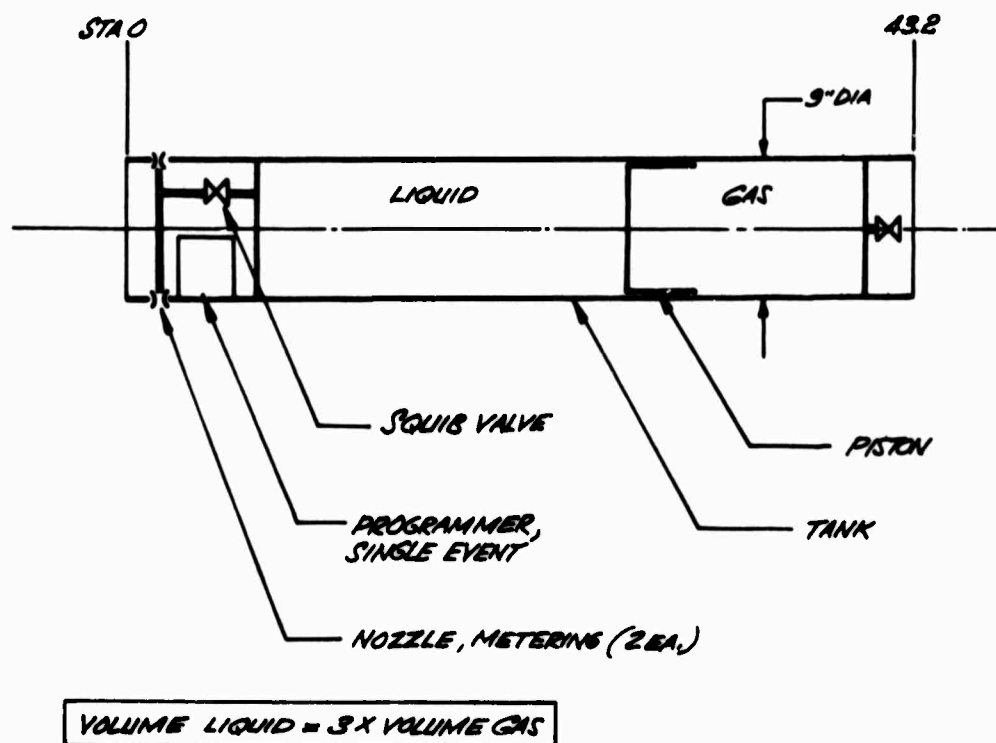

FIGURE 3 TMA TRAIL RELEASE MODULE (308-11)

## 2.5 TMA Trail Payload (Baffled Tank) (299-11).

Approximately 2.5 pounds of TMA were released as a continuous trail at a desired release rate. A single event programmer opened a squib valve allowing TMA to flow through a single metering orifice. Release rate was controlled by the nitrogen pressure, and nozzle size.

The tank was aluminum with a combination of brazed and threaded joints.

Baffles were placed in the tank so that vehicle spin and coning would force the liquid forward and against the cylinder walls of the tank to aid liquid venting.

Figure 4 is a functional sketch of this payload.

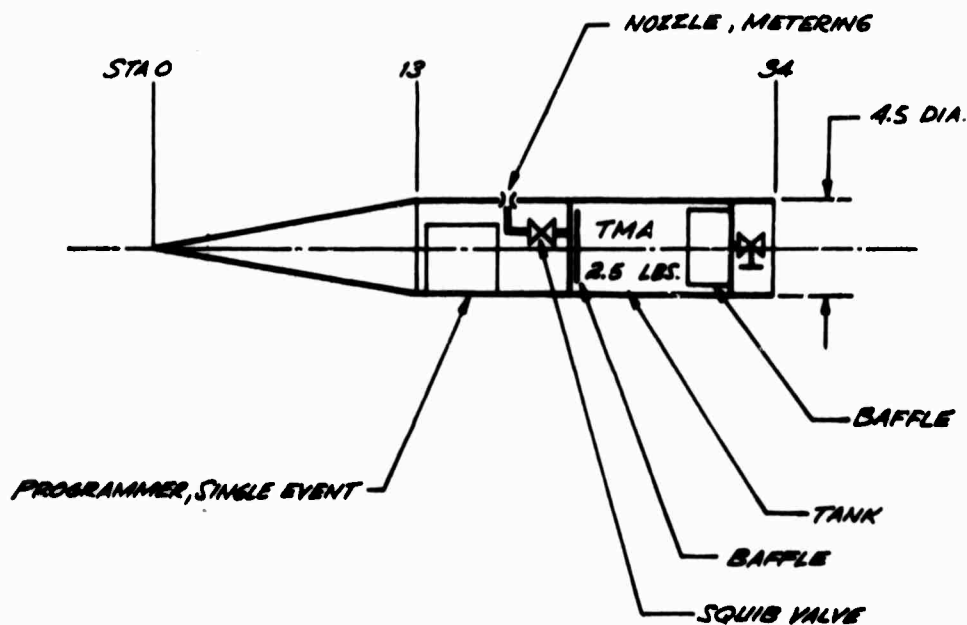

FIGURE 4 TMA TRAIL MODULE (BAFFLED TANK)(299-11)

2.6 TMA Four "Point" Payload (213-11).

TMA was sequentially released in four bursts (less than one second each) of 4.5 pounds each, from four separate tanks. Signals from a multievent programmer sequentially energized a pyrotechnic hot gas accumulator contained in each tank.

As the pressure exceeded 500 psi, a rupture disc failed, allowing release through ports on the side of the payload.

Figure 5 is a functional sketch of this payload.

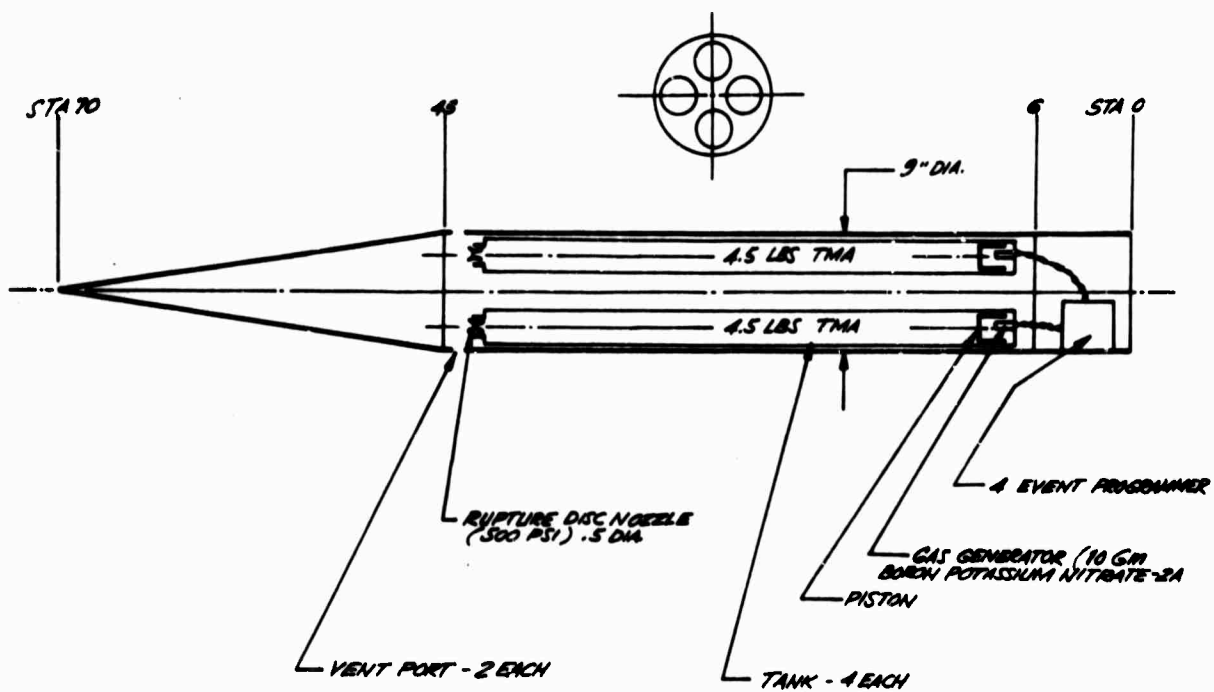

FIGURE 5 TMA FOUR POINT PAYLOAD (213-11)

## 2.7 TMA Intermittent Release Payload.

TMA was released in intermittent bursts of varying durations and duty cycles. TMA payload types similar to that described in sections 2.4, except for dimensions and quantities contained, were attached to one of the following intermittent release systems to give the desired release profile:

- (1) Cam operated toggle valve (284-11)(284-12)
- (2) Geneva mechanism operated ball valve (284-200)
- (3) Solenoid actuated multi-valve (322-11)
- (4) Solenoid actuated single valve (371-10)

Figure 6 is a functional sketch of the TMA Intermittent Release (Solenoid Actuated Valve) payload.

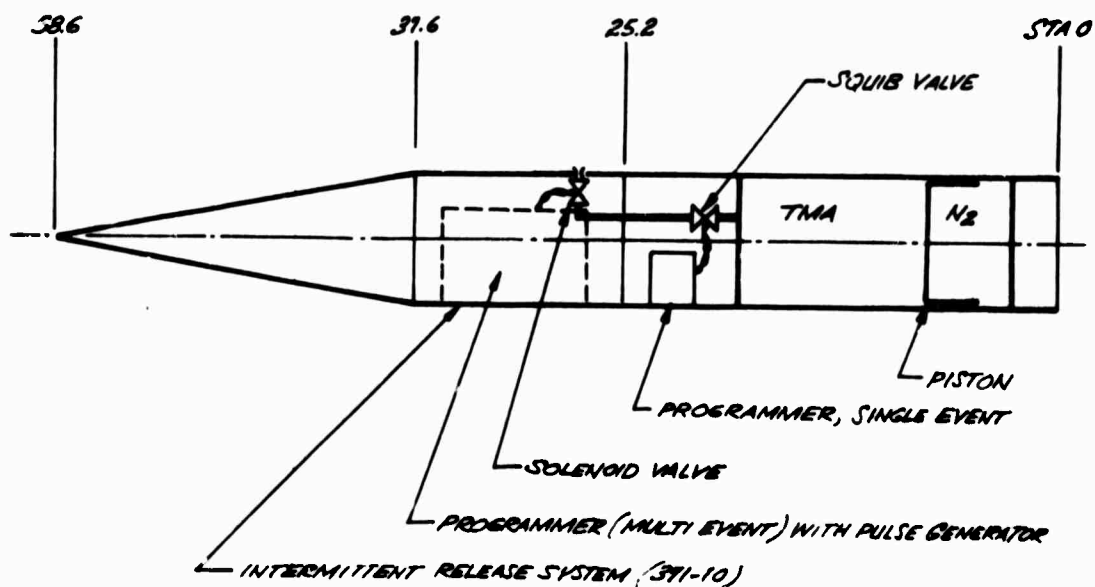

FIGURE 6 TMA INTERMITTENT RELEASE PAYLOAD (SOLENOID VALVE)

## 2.8 High Explosive Payload (278-11).

Thirty pounds of high explosives seeded with metals were detonated to provide a single point release. Two high explosive charge formulations were provided:

- (1) 34 % RDX, 46% TNT and 20% Beryllium
- (2) 34 % RDX, 46% TNT and 20 % Magnesium

The explosive constituents were melted at 90° C. Metal constituents were added to the explosives, mixed and cast directly into the payload canister. A combination of composition B and TNT was used to provide the required RDX and TNT percentages.

A single event programmer electrically initiated an explosive train consisting of an electro-explosive detonator and composition C4 booster.

Figure 7 is a functional sketch of this payload.

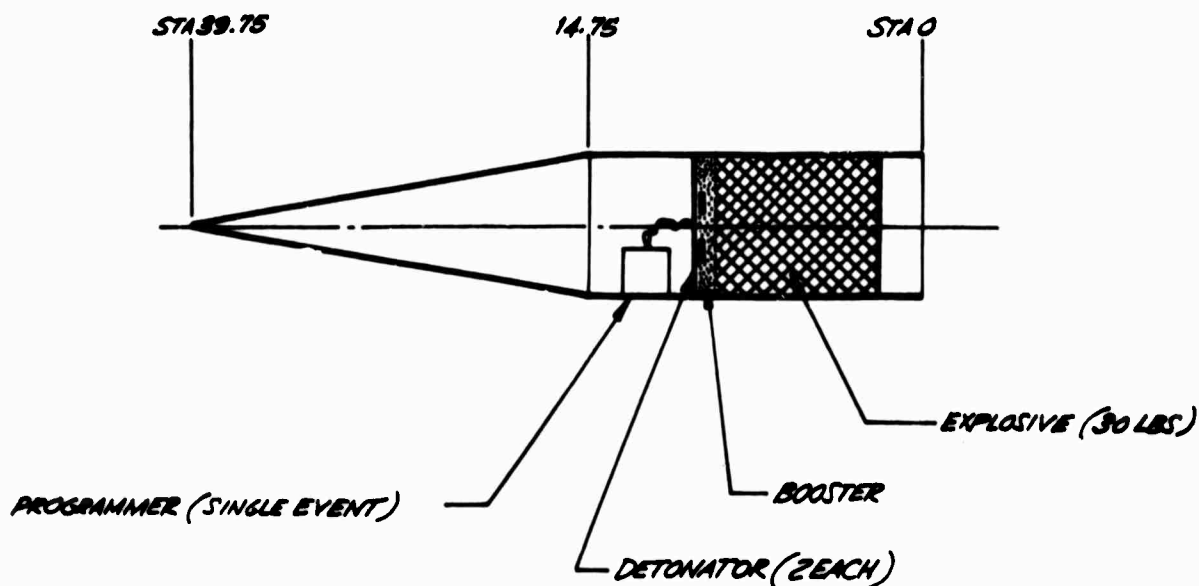

FIGURE 7 HIGH EXPLOSIVE PAYLOAD (278-11)

2.9 Barium Three Burner Payload (309-12).

Three barium burners were carried in a single envelope. Release was sequentially initiated with a multievent programmer. Reaction products from each burner were vented through a single nozzle.

Figure 8 is a functional sketch of this payload.

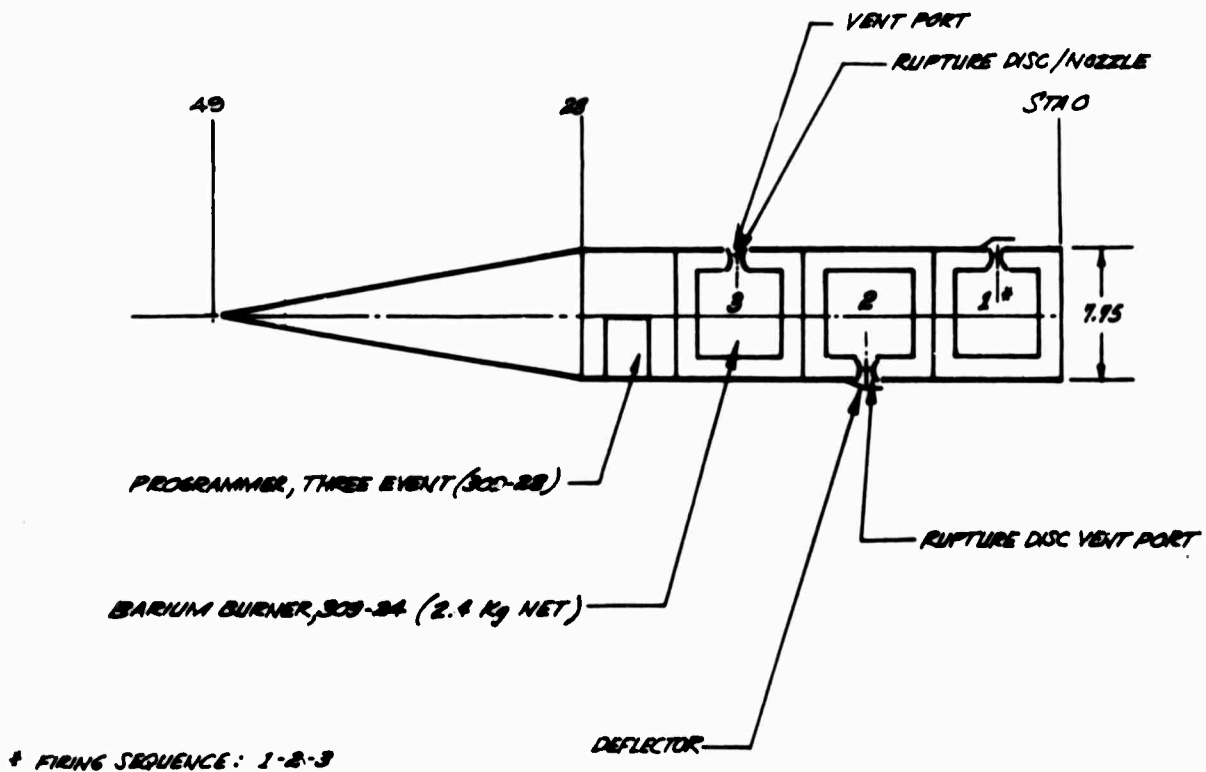

FIGURE 8 BARIUM 3-BURNER PAYLOAD (309-12)

**2.10 Barium Modules (319-11, 333-11).**

Both 2.4 and 6 Kg net modules were provided. Each module consisted of a Barium burner, single event programmer and an aerodynamic envelope.

Figures 9 and 10 are functional sketches of the 3 module 319-11 and 333-11 payloads respectively.

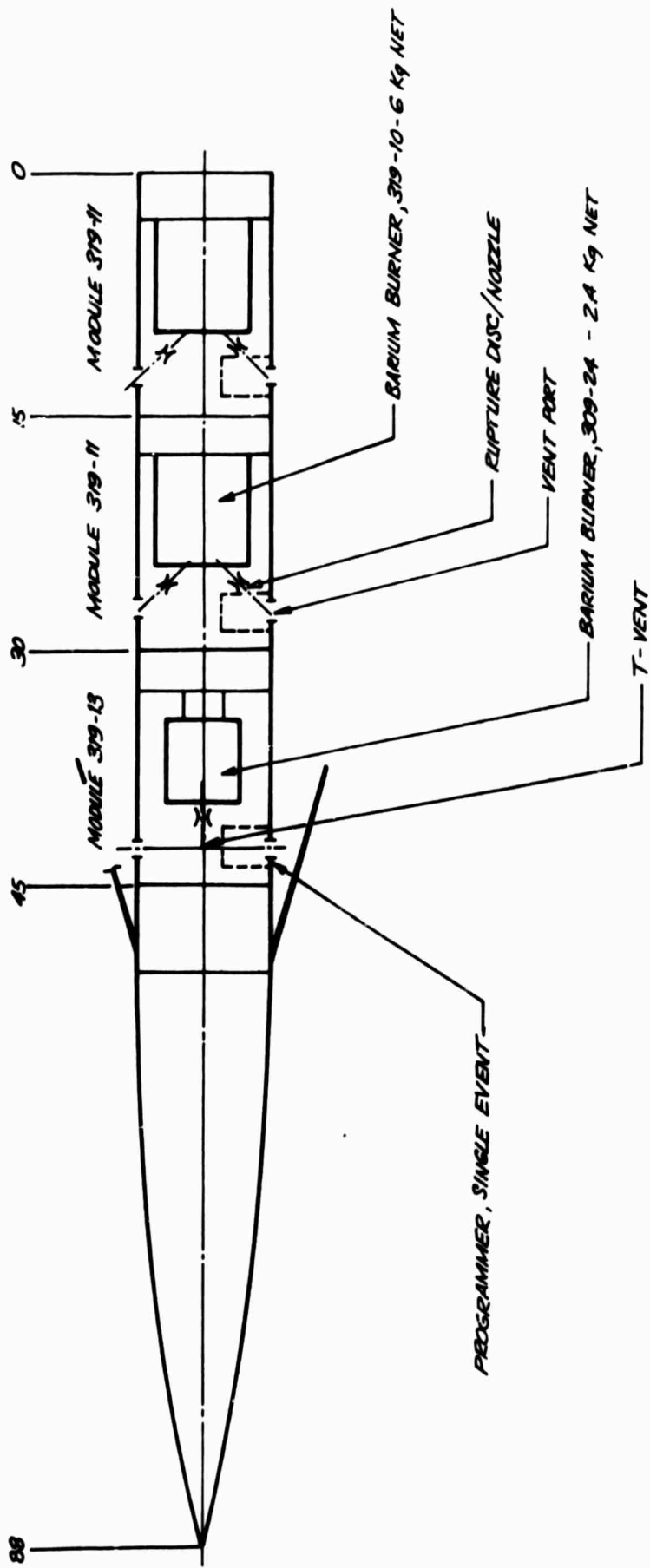

FIGURE 9 BARIUM 3-MODULE PAYLOAD (319-12)

A-1970

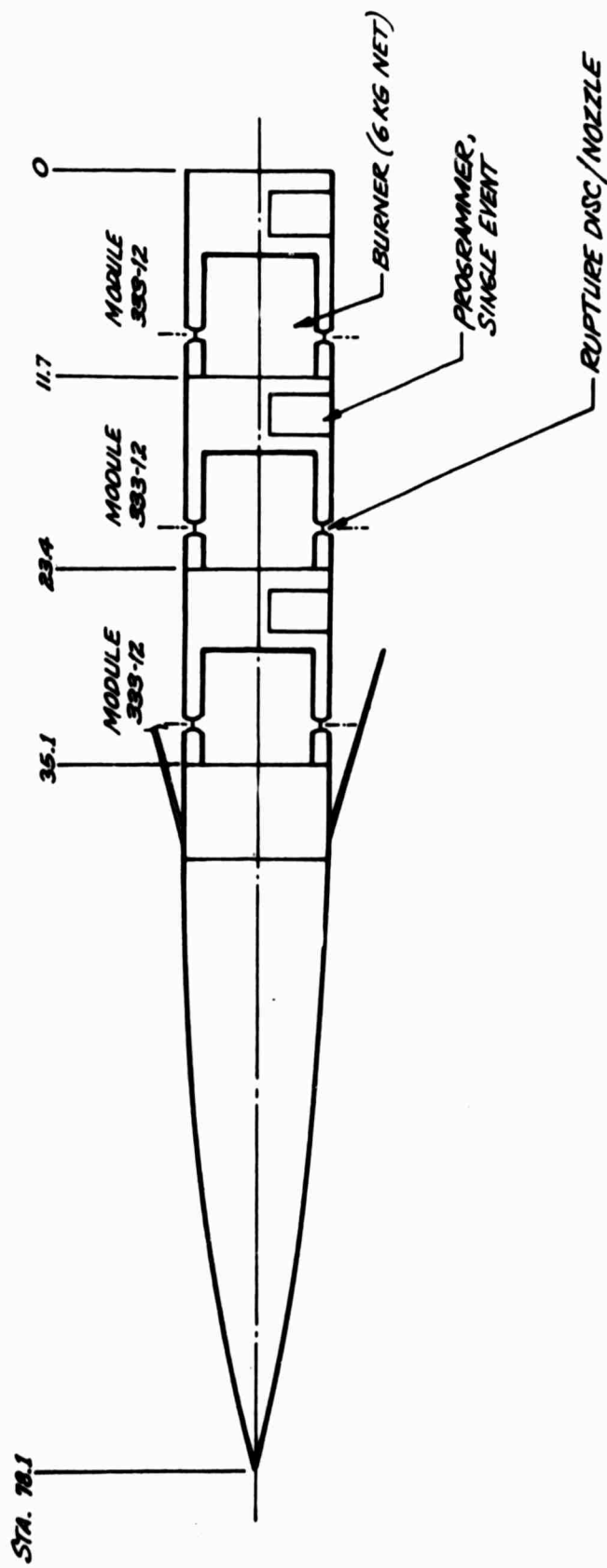

FIGURE 10 BARIUM THREE MODULE PAYLOAD (333-13)

A-1971

## 2.11 Barium Delayed Release (large void) Payload (351-10 and 363-10).

The Barium/Copper Oxide mixture was released by cutting the Barium can circumferentially 0.25 seconds after ignition. A single event programmer fired the Barium burner. Burning pressure (i.e., to 700 PSI) closed a pressure switch (300 PSI) in the lid separation device which in turn, fired a delay detonator ignition train to a shaped charge. The shaped charge cut the can circumferentially, allowing instantaneous release of the burner contents.

Two sizes of this payload were provided. Part number 351-10 carried 48 pounds of Barium/Copper Oxide, whereas part number 363-10 carried 12 pounds of Barium/Copper Oxide. Figure 11 and 12 are functional sketches of these two payloads respectively.

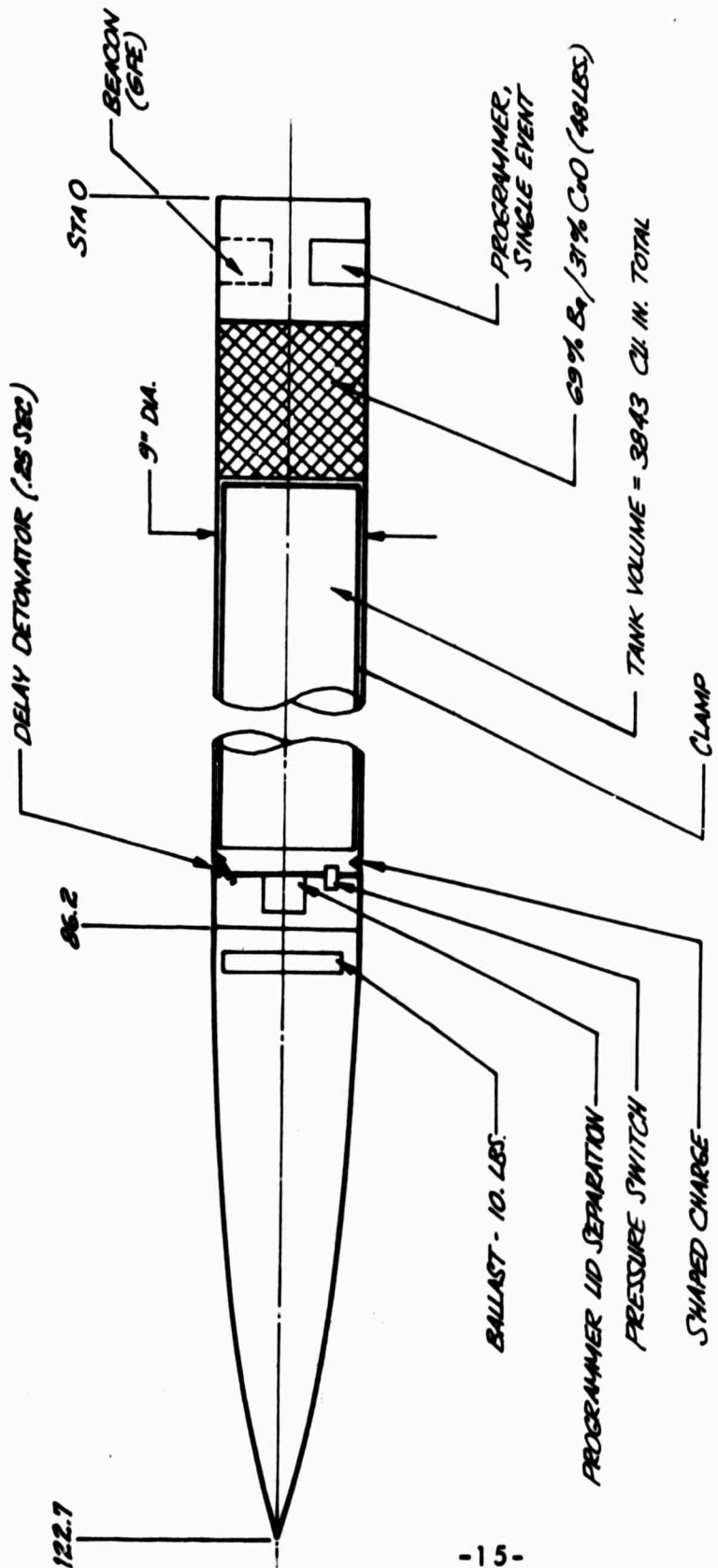

GROSS WT. = 254 LBS.

FIGURE 11 BARIUM DELAYED RELEASE (LARGE VOID) PAYLOAD (351-10)

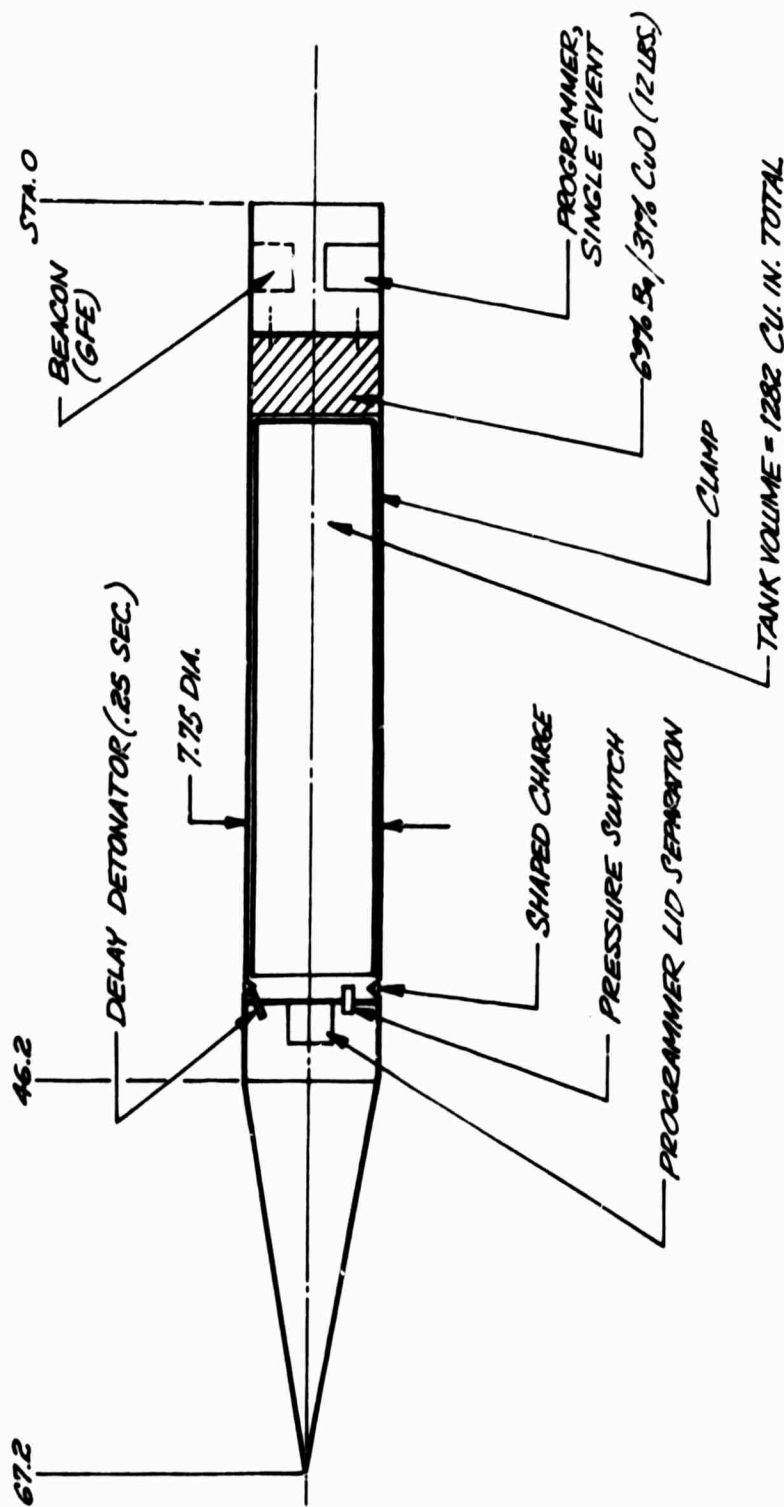

GROSS WT. = 83 LBS.

FIGURE 12 BARIUM DELAYED RELEASE (LARGE VOID) PAYLOAD (303-10)

A-1974

2.12 Cesium Nitrate/Aluminum/Tungsten Payload (362-10).

Approximately 5.5 pounds of an end burning mixture of Cesium Nitrate, Aluminum/Tungsten compound produced a trail release of approximately 30 seconds duration. At launch a pyrotechnic delay squib was electrically initiated and ignited an ignition train to the thermite mix. Reaction products were vented through graphite insulated nozzles.

Figure 13 is a functional sketch of this payload.

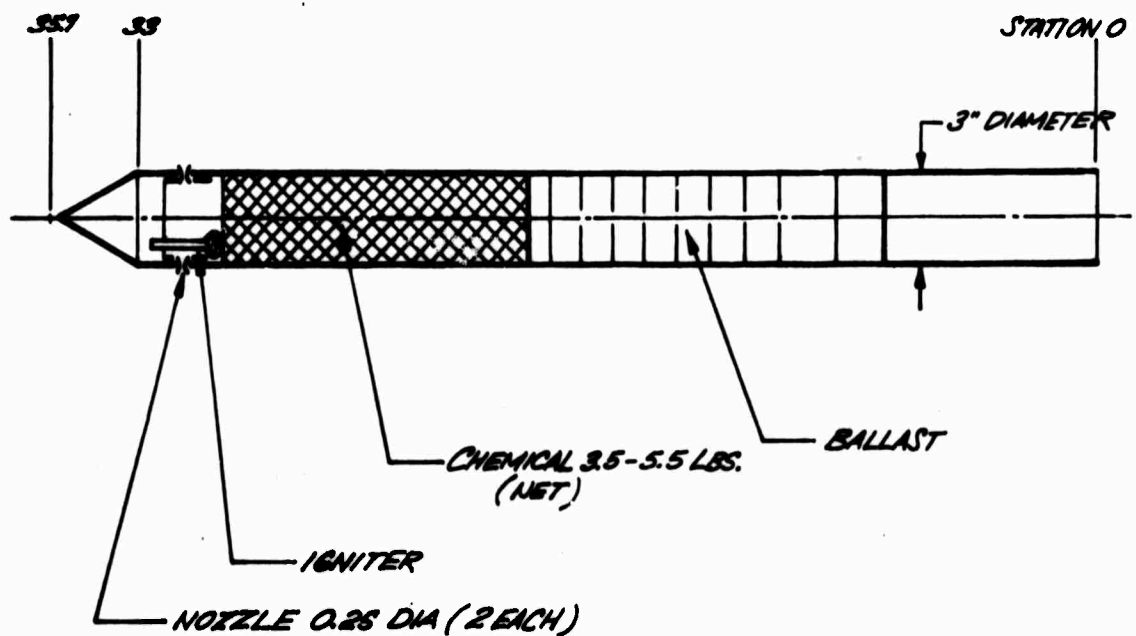

FIGURE 13

CESIUM NITRATE/ALUMINUM/TUNGSTEN PAYLOAD (362-10)

### 3. SUBSYSTEMS

#### 3.1 General.

A major objective of this program was to develop an inventory of standardized subsystems that, when combined, could be used to satisfy a large variety of scientific requirements to perform controlled releases of gases, liquids or solids with a minimum modification of basic subsystems and maximum flexibility to meet scientific requirements.

Subsystems have been categorized as to function and part number. Hopefully, this will enable the reader, who has chemical payload requirements, to select the subsystems that will meet his future requirements.

#### 3.2 Fluid Controls.

##### 3.2.1 General.

Fluid controls directed or regulated the flow of fluids from the chemical tank into the atmosphere. Fluid controls have been classified as fittings, squib valve, intermittent release system and nozzles.

##### 3.2.2 Fittings.

During this program numerous types of plumbing fittings have been tried, i.e., tapered pipe thread, Swag Lok, 45° and 37° flare and SAE O-ring port fittings. For chemical payload applications, including loading systems, the 37° flare, SAE O-ring port fittings have proven to be the most reliable. These fittings may be disassembled repeatedly without damage and the design enables compact lightweight packaging in payload systems.

### 3.2.3 Squib Valve.

This valve was developed to provide a reliable method of releasing reactive liquids and gases from chemical tankage. The valve has a 0.5-inch port size, 5000 psi working pressure and seals prior to firing are metal-to-metal. Figure 14 illustrates the valve.

When the valve is fired, an electro-explosive, 1 amp, 1 watt, maximum no-fire squib, in combination with boron potassium nitrate propellant imparts energy to a piston that breaks a nipple at a fail section.

The valve has been hydrostatically tested to 15,000 psi without failure, and has been ground and flight functionally tested more than 100 times with working pressure of 0 - 3200 psi with all valves functioning satisfactorily. The valve was environmentally tested to the flight environment specifications described in Appendix A. Detailed test results are presented in Appendix C.

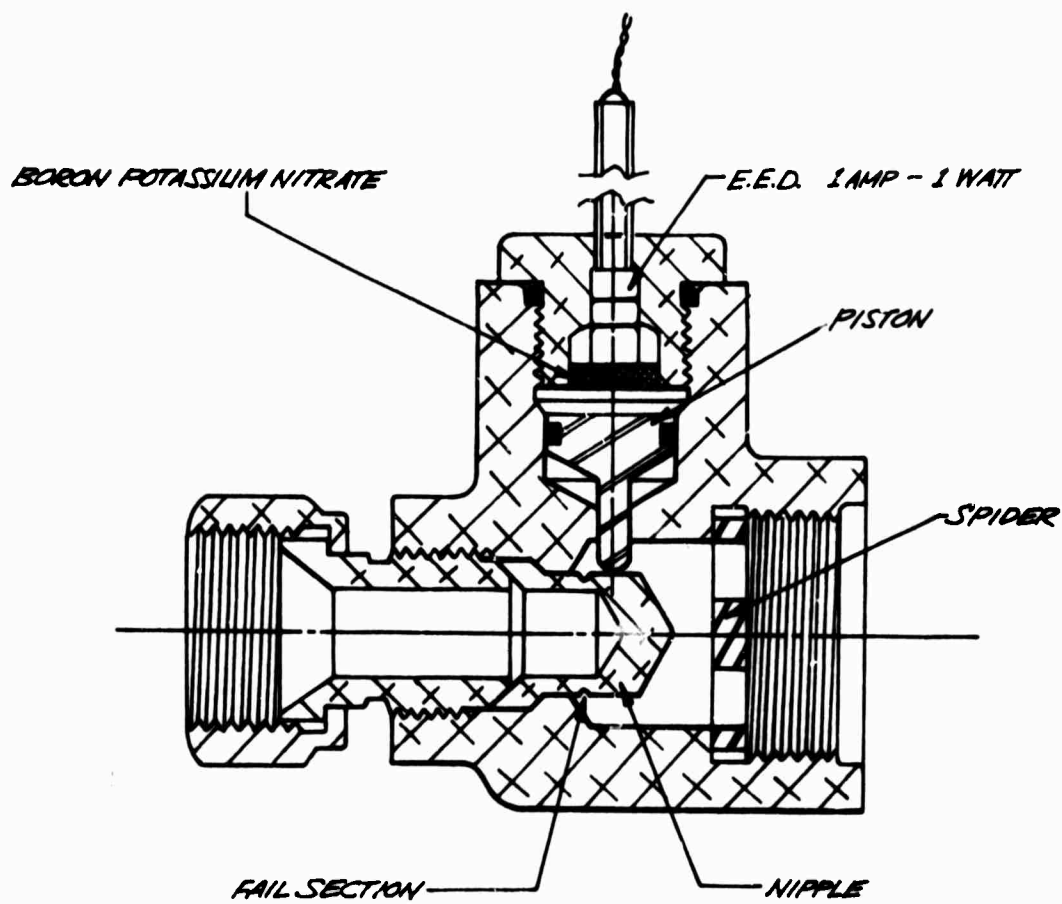

FIGURE 14 SQUIB VALVE (273-10)

### 3.2.4 Intermittent Release Systems.

3.2.4.1 General. The systems were developed to provide an interrupted release profile of various pulse durations and duty cycles. Three techniques were used:

1. Cam operated toggle valve,
2. A Geneva mechanism operated ball valve,
3. Solenoid actuated valves.

#### 3.2.4.2 Cam Operated Toggle Valve (284-11 and 284-12).

A DC motor driven cam was used to operate a commercially available toggle valve to give the desired open and closed sequence. The advantage of the system is simplicity. Disadvantages include; (1) reaction time is limited by geometry and inertia, (2) the operational sequence is fixed by the cam design, although new cams may easily be substituted.

The operating characteristics of this system are:

- |                                |   |
|--------------------------------|---|
| 1. Maximum total cycle time    | 2.5 seconds                               |
| 2. Minimum total cycle time    | 0.9 seconds                               |
| 3. Maximum operating pressure  | 200 psi (Valve cracking pressure 210 psi) |
| 4. Total cycle times available | 2.5, 1.1, 1.5 and 0.9 seconds             |

The cam profile requires 15 degrees ramp angle to fully open the valve. The closing ramp may be less, however, by having them equal, the direction of the motor rotation due to polarity has no effect on valve operation. Appendix B gives test results for this system. This system is illustrated in Figure 15.

The system 284-11 was refined by replacing the roller type cam follower with a ball detent giving a direct mechanical linkage between the cam and the valve poppet, (284-12).

#### 3.2.4.3 Geneva Mechanism Operated Ball Valve (284-13).

The advantage of this system over P/N 284-11 is that a longer cycle time is available. A d. c. motor driven Geneva mechanism actuated a commercial ball valve. This system is illustrated in Figure 16.

The operational characteristics of this system are:

1. Maximum total cycle time 4.7 seconds
2. Minimum total cycle time 1.9 seconds
3. Total cycle times available 4.7, 3.3, 2.4, 1.9 seconds.
4. Limitations: The valve open time equals close time and the time to actuate the valve from full closure to fully open and vice versa is 25% of the total cycle time.

Appendix D gives test results for this system.

3.2.4.4 Solenoid Actuated Valves (322-11 and 371-10). These systems were developed to give fast operating response and provide flexibility so that the sequence may be easily set. Solenoid actuated valves were electrically pulsed with an electronic valve sequencer. Pulse time and duty cycle time were set by two individual knob adjustments on the sequencer (adjusting the resistance value of an R-C circuit.) Programmer elements are described further in Section 3.4. Figure 17 gives functional sketches of two systems provided. One system contained three solenoid valves (322-1) whereas the other system contained one solenoid valve, (371-10). Both systems featured two valve sequencers, each giving a different release profile (i. e., Sequencer No. (1), pulse duration, 0.25 seconds, duty cycle 3 seconds. Sequencer No. (2), pulse duration, .75 seconds, duty cycle, 15 seconds.)

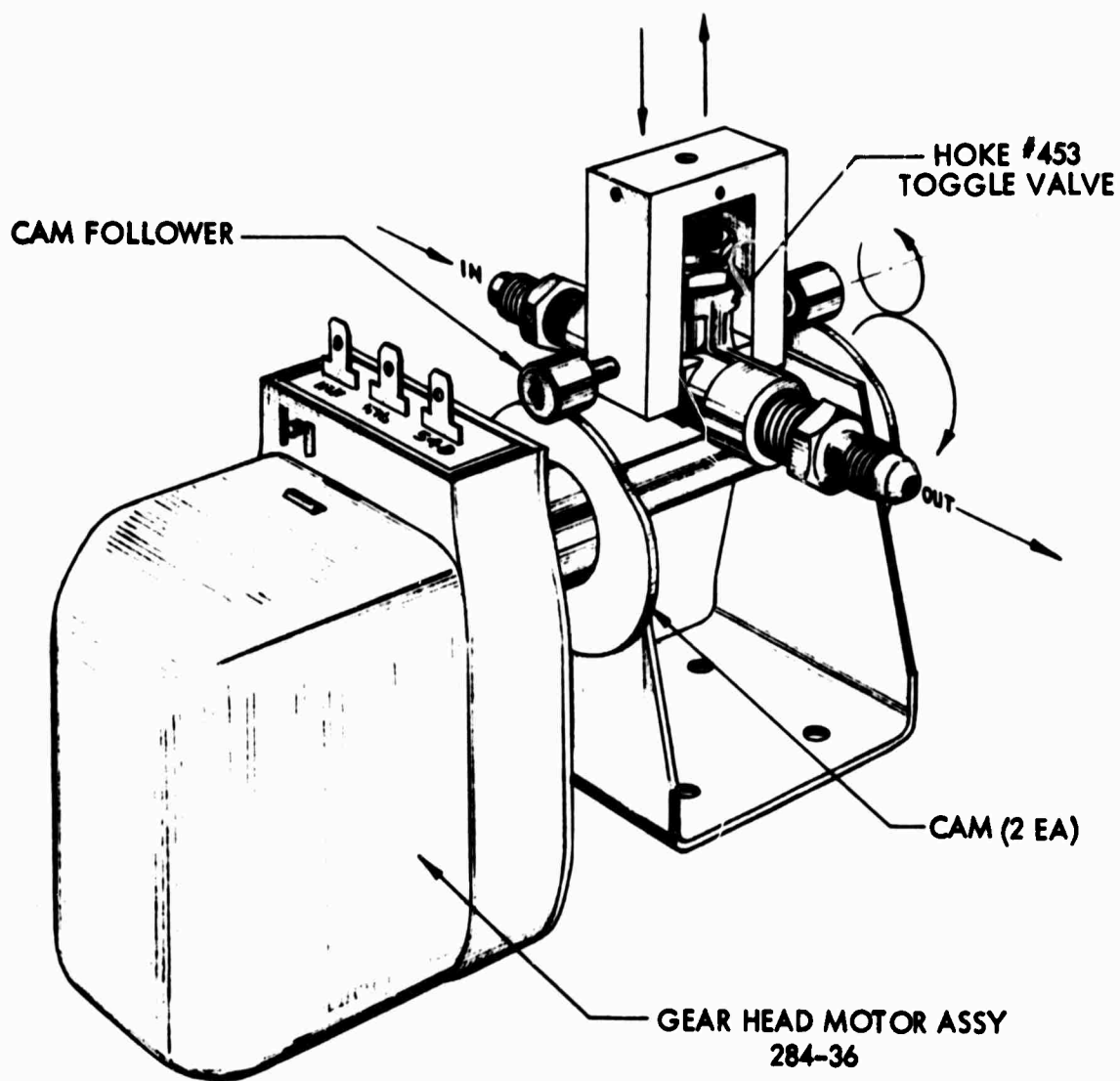

FIGURE 15 CAM OPERATED TOGGLE VALVE (284-11)

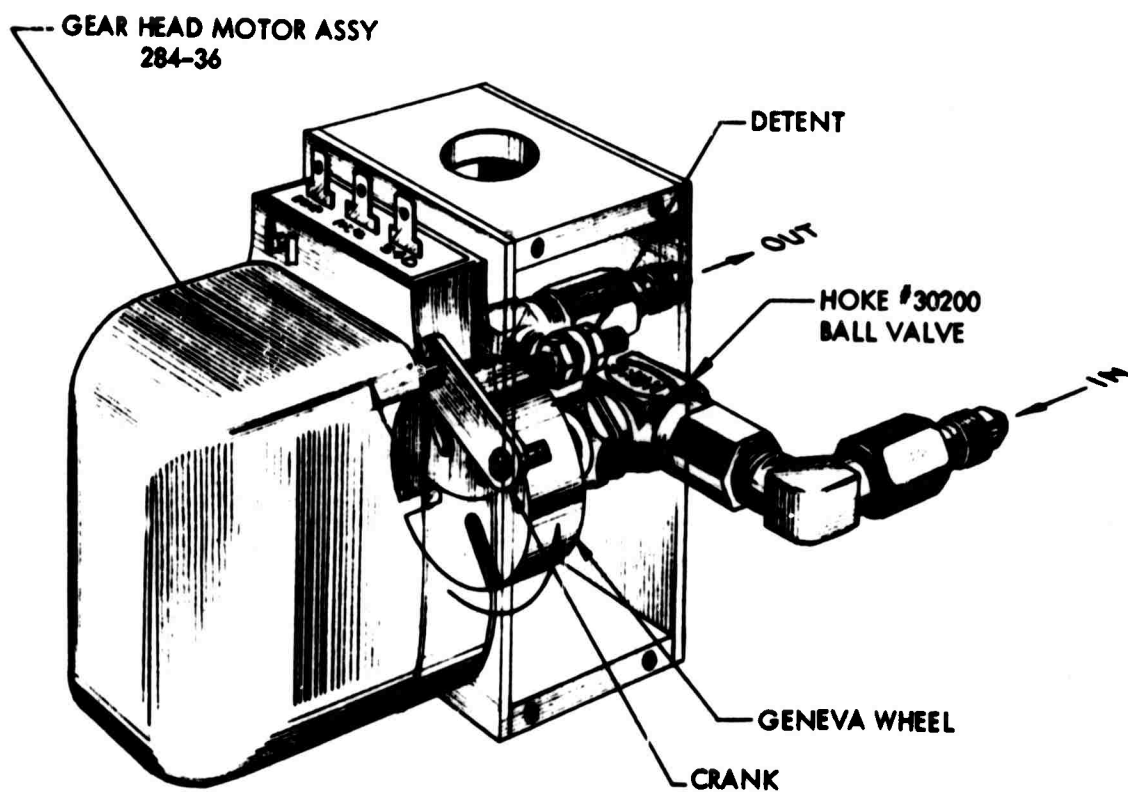
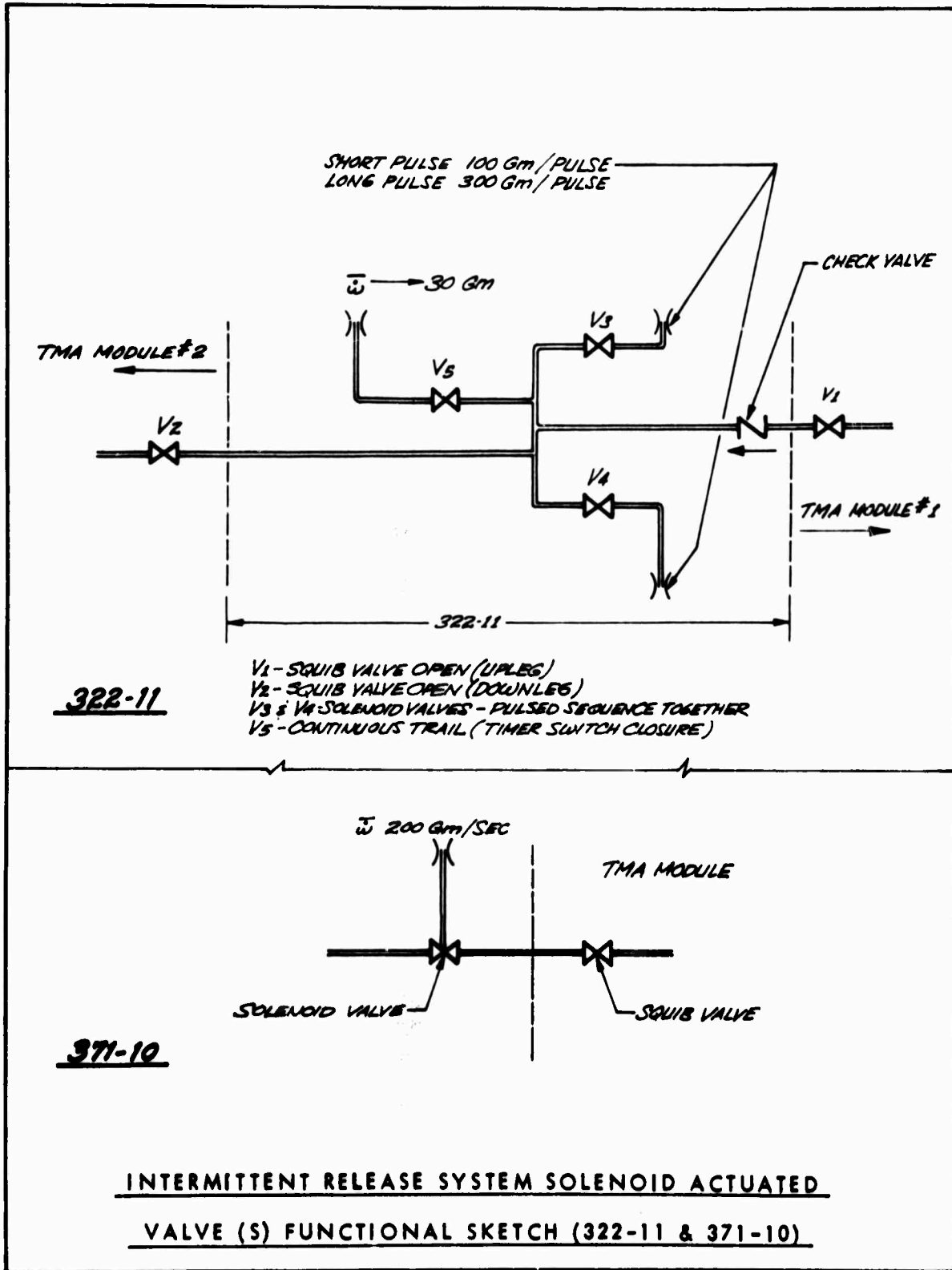

FIGURE 16 GENEVA MECHANISM OPERATED BALL VALVE (284-13)



### 3.2.5 Nozzles.

3.2.5.1 General. Three types of nozzles were provided; (1) metering, (2) liquid atomizing and (3) rupture disc. The rupture disc nozzle consisted of a rupture disc combined with a metering nozzle. Figure 18 illustrates these nozzles.

3.2.5.2 Metering Nozzle. The diameter of a metering nozzle was varied as a method to adjust flow rate. A simple flat plate orifice was used. In most cases, the orifice was drilled into a plug which threaded directly into the payload envelope, thus the orifice size could be easily adjusted. Figure 19 is a plot of average release rate versus metering nozzle diameter showing typical relationship between flow rate and nozzle size at a constant initial accumulator pressure.

3.2.5.3 Atomizing Nozzles. Two types of liquid atomizing nozzles were considered as a method of atomizing TMA during release. (1) A gas atomizing nozzle which uses the energy of a high velocity gas stream to atomize the liquid and (2) a hollow cone nozzle which depends upon the liquid impingement against a hard surface or the atmosphere to break up the liquid. Particle size obtainable with various off-the-shelf nozzles were found to be as follows:

|               |                           |
|---------------|---------------------------|
| Hollow cone   | 10-40 microns at 500 psi  |
| Hollow cone   | 50-100 microns at 100 psi |
| Gas Atomizing | 10-40 microns at 60 psi   |

The major advantages of the hollow cone nozzle are (1) small size, (2) desired flow rates, (3) simplicity. The gas atomizing nozzle would require a gas reservoir and available off-the-shelf systems would not provide the desired flow rates without using multiple nozzles.

Methods of determining particle size were investigated. The approach used was to measure the time for the particles to fall 10 feet and compare these fall rates with the information given in Table 1. Test results seemed to compare fairly well with data given by the nozzle supplier for the nozzles selected. Figures 20 through 22 give particle size information and Figure 23 gives flow rate versus liquid pressure for various hollow cone nozzles selected.

3.2.5.4 Rupture Disc Nozzles. Release was initiated through the rupture disc nozzle at a predetermined pressure by either pressurization of a hot gas accumulator (312-11) or burning pressure of a barium burner (i.e., 309-24).

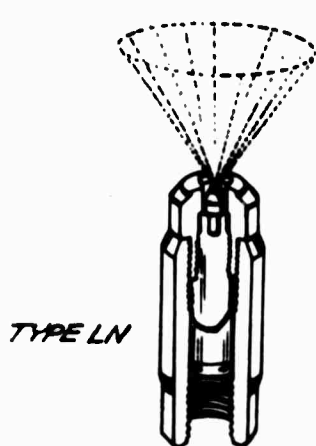

TYPE LN

HOLLOW CONE  
ATOMIZING

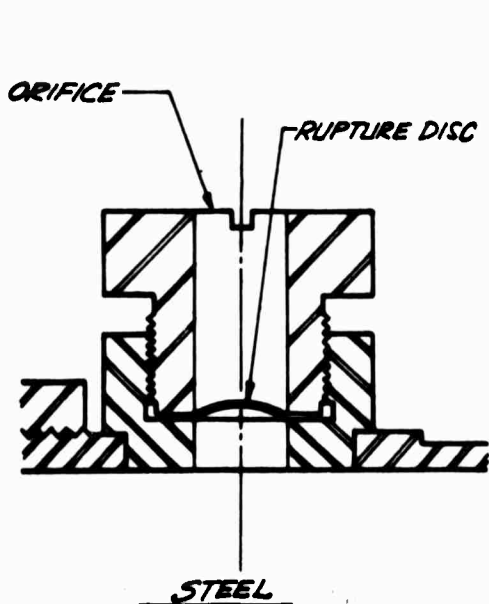
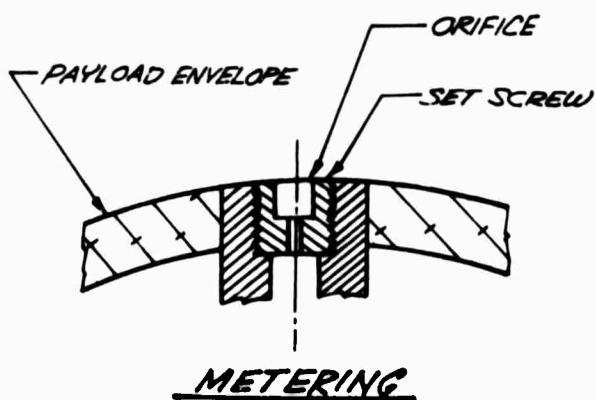

ORIFICE

RUPTURE DISC

STEEL

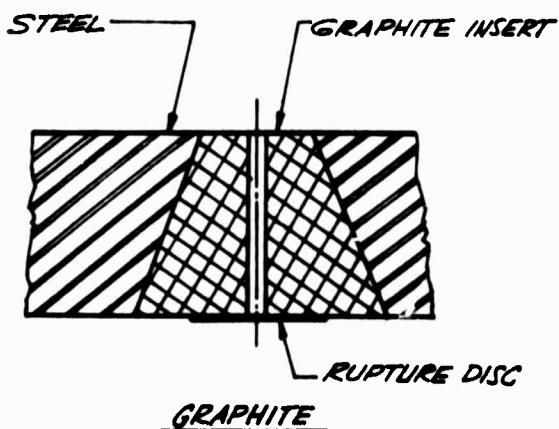

RUPTURE DISC

FIGURE 18 NOZZLE TYPES

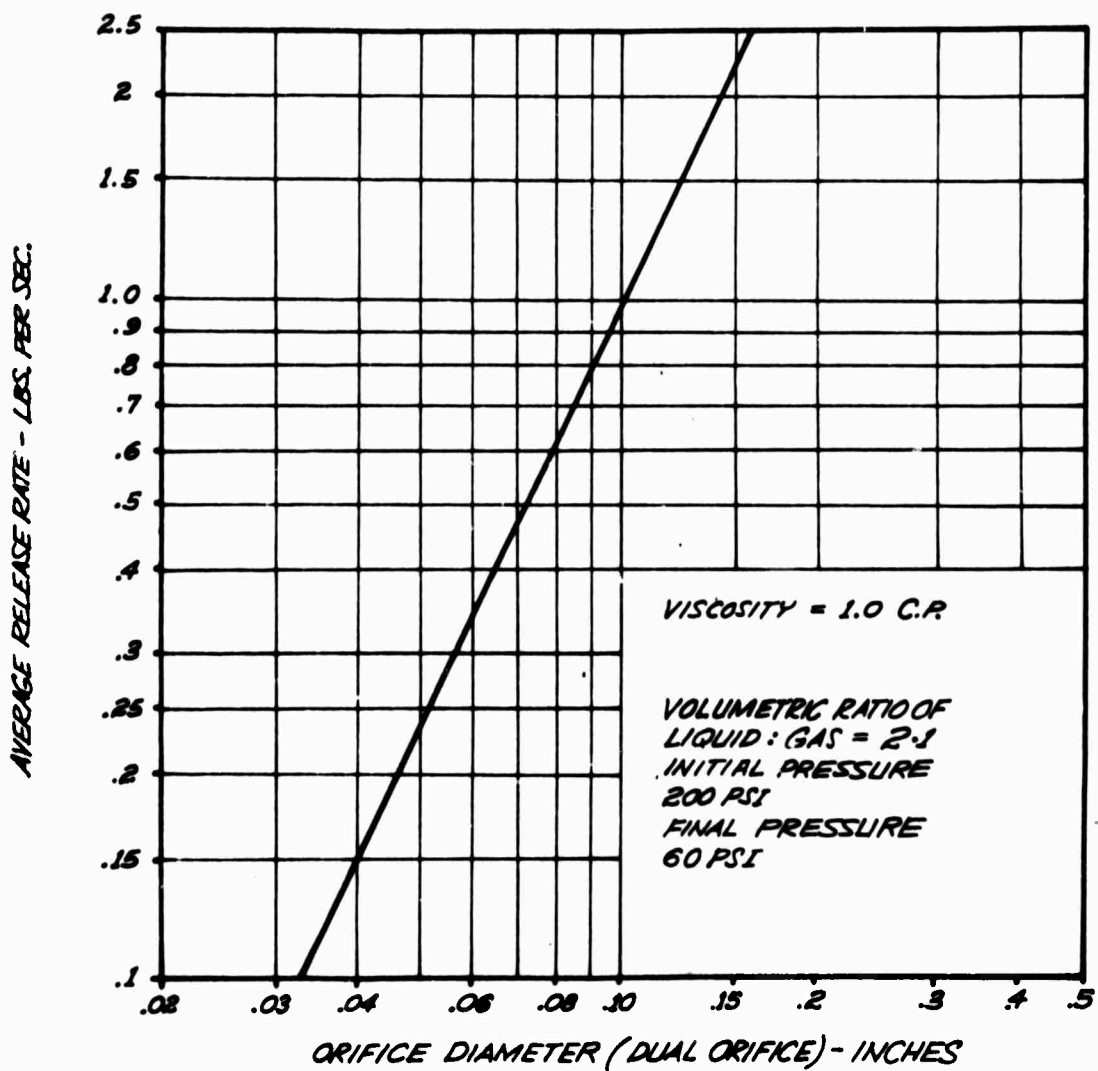

FIGURE 19

AVERAGE RELEASE RATE VERSUS ORIFICE DIAMETER  
METERING NOZZLE

| Particle Size Range Microns* | Comparative Subject Particle Size Range | Time for Particle to Fall 10 ft. In seconds | Drift in 3 MPH Wind 10 Ft. Fall In Feet | No. of Particles per Sq. In. if applied at Rate of 1 Gal/Acre | Nozzle Types and Sizes Generally Falling in Given Particle Size Range Under Stated Condition.  |
|------------------------------|---|---|---|---|--|
| Below .001                   | Molecular Dimensions                    | -   | -                                       | -   | -----  |
| .001 to 0.1                  | Smoke                                   | **  | -                                       | -   | -----  |
| 0.1 to 1.0                   | Fumes                                   | **  | -                                       | -   | -----  |
| 2 to 5                       | Dry Fog                                 | 25400<br>4070                               | 112000<br>18000                         | 14400000<br>9229999   | Small Pneumatic Atomizing Syphon nozzle set-ups operating at the higher air pressures.   |
| 10 to 40                     | Wet Fog                                 | 1020<br>64                                  | 4500<br>280                             | 1152500<br>18000  | Pneumatic Atomizing nozzles; small capacity atomizing and spray dry type nozzles operating at high pressures (500 psi and up).             |
| 50 to 100                    | Misty Rain                              | 40<br>11                                    | 175<br>48                               | 9200<br>1152  | Large capacity Pneumatic atomizing nozzles; the larger capacity atomizing and Teejet nozzles operating at pressures around 100 psi.        |
| 200 to 400                   | Light Rain                              | 4.2<br>1.9                                  | 19<br>8                                 | 144<br>18   | The smaller capacity Whirljets, Full jets, and Veejet nozzles operating at pressures around 40 psi.  |
| 500 to 1000                  | Moderate Rain                           | 1.6<br>1.1                                  | 7<br>5                                  | 9<br>1  | Intermediate sizes of Whirljet, Fulljet and Veejet nozzles, approximately in the range of 5 to 15 GPM spraying at pressures around 40 psi. |
| 2000 to 5000                 | Heavy Rain                              | 0.9<br>0.85                                 | 4<br>3.5                                | 21 per sq. ft.<br>1-1/3 per sq. ft.                           | The large size hydraulic nozzles operating at pressures around 10 and 20 psi and intermediate sizes operating at very low pressures.       |

\* Note: One micron equals 1/25400 of an inch. There are 25.4 microns to .001 (one thousandth) of an inch.

\*\* Note: Below 0.1 micron, particles are suspended in air due to molecular shock (Brownian Motion).

Provided by Spraying Systems

TABLE 1 COMPARATIVE PARTICLE SIZE DATA

A-1979

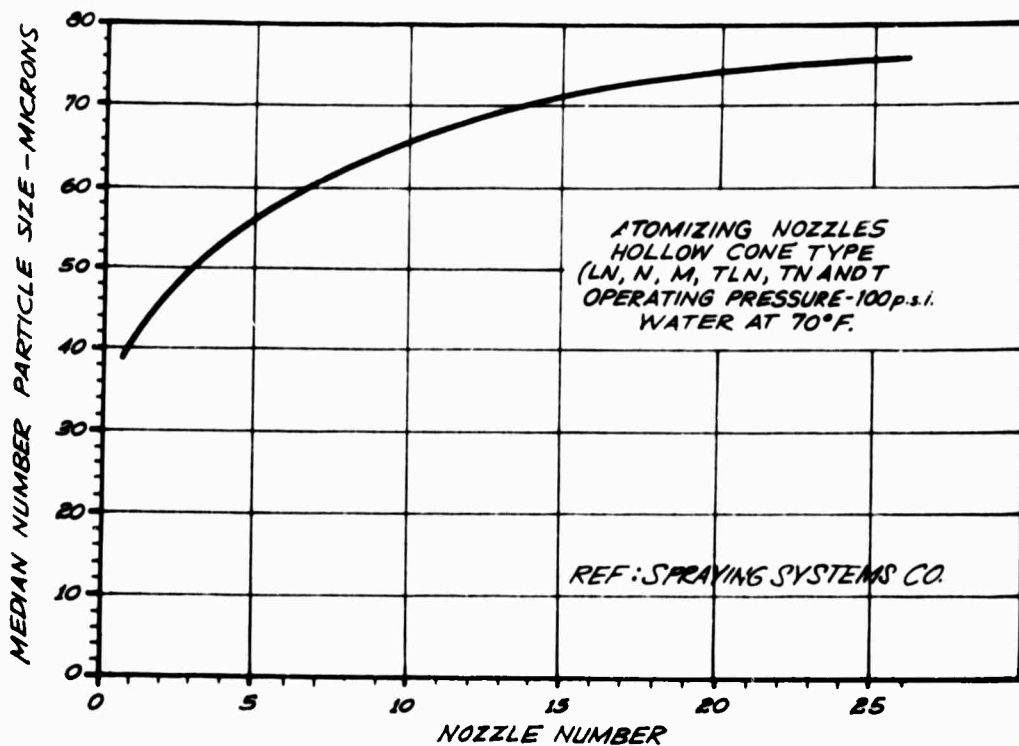

FIGURE 20

PARTICLE SIZE vs NOZZLE NUMBER - HOLLOW CONE NOZZLE

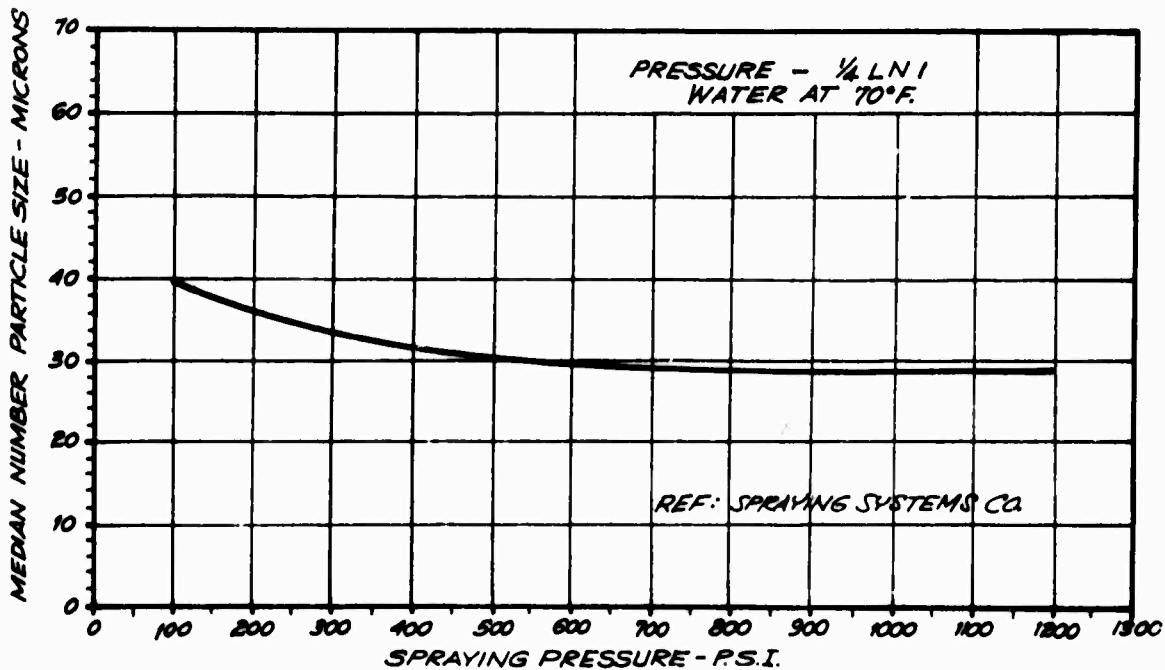
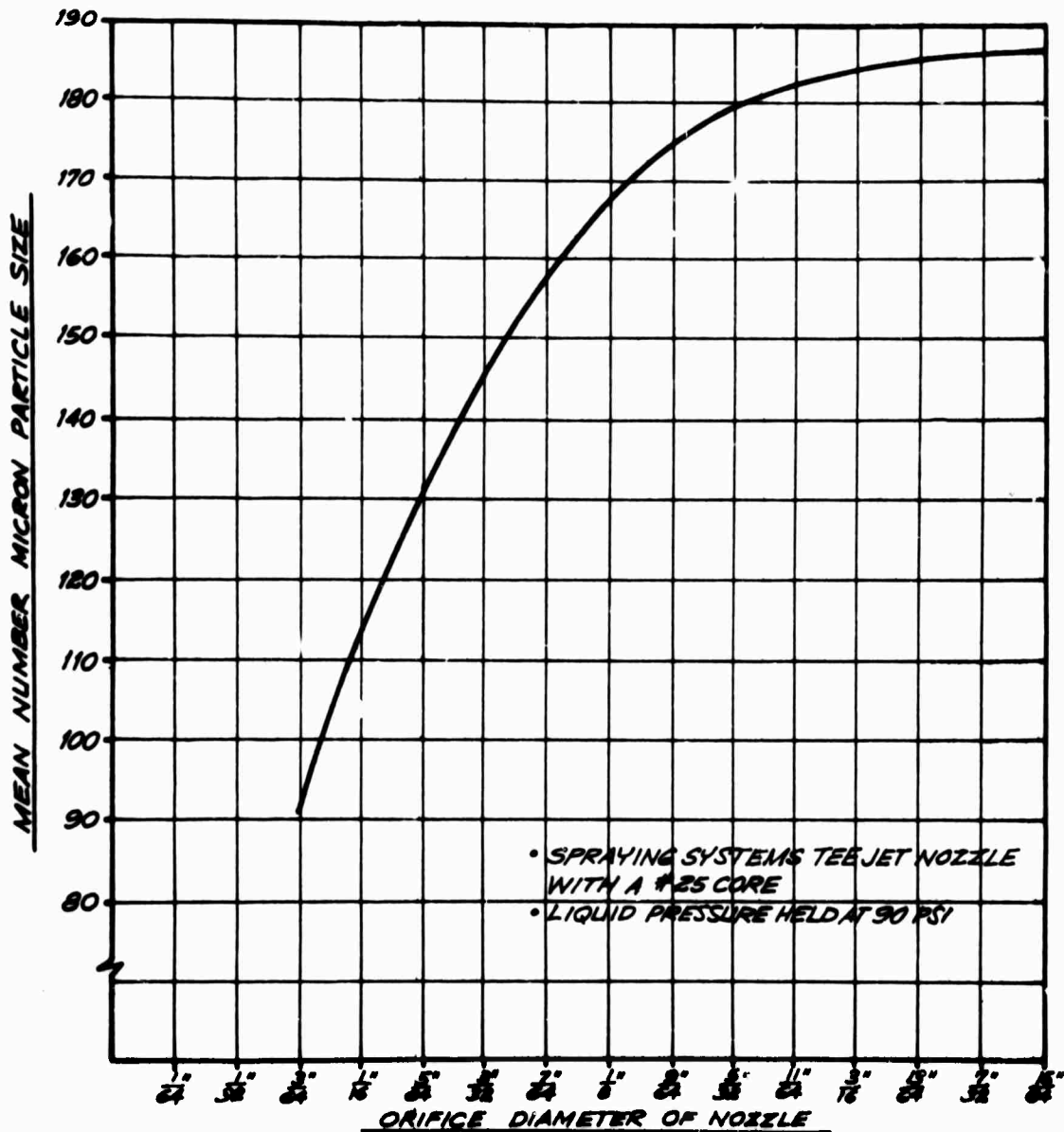

FIGURE 21

PARTICLE SIZE vs SPRAYING PRESSURE - HOLLOW CONE NOZZLE



NOTE: IN THE DISC TYPE TEEJET NOZZLE THE PART NO. OF THE INTERCHANGEABLE DISC ORIFICE CORRESPONDS TO THE NUMBER OF  $\frac{1}{32}$ 'S IN THE ORIFICE DIAMETER.

READINGS FOR THIS GRAPH WERE TAKEN WITH WATER AT TEMPERATURE OF 72°F. AND ROOM TEMPERATURE OF 72°F. - AT DISTANCE OF 2' FROM NOZZLE.

FIGURE 22

PARTICLE SIZE vs NOZZLE ORIFICE DIAMETER  
HOLLOW CONE NOZZLE (TN)

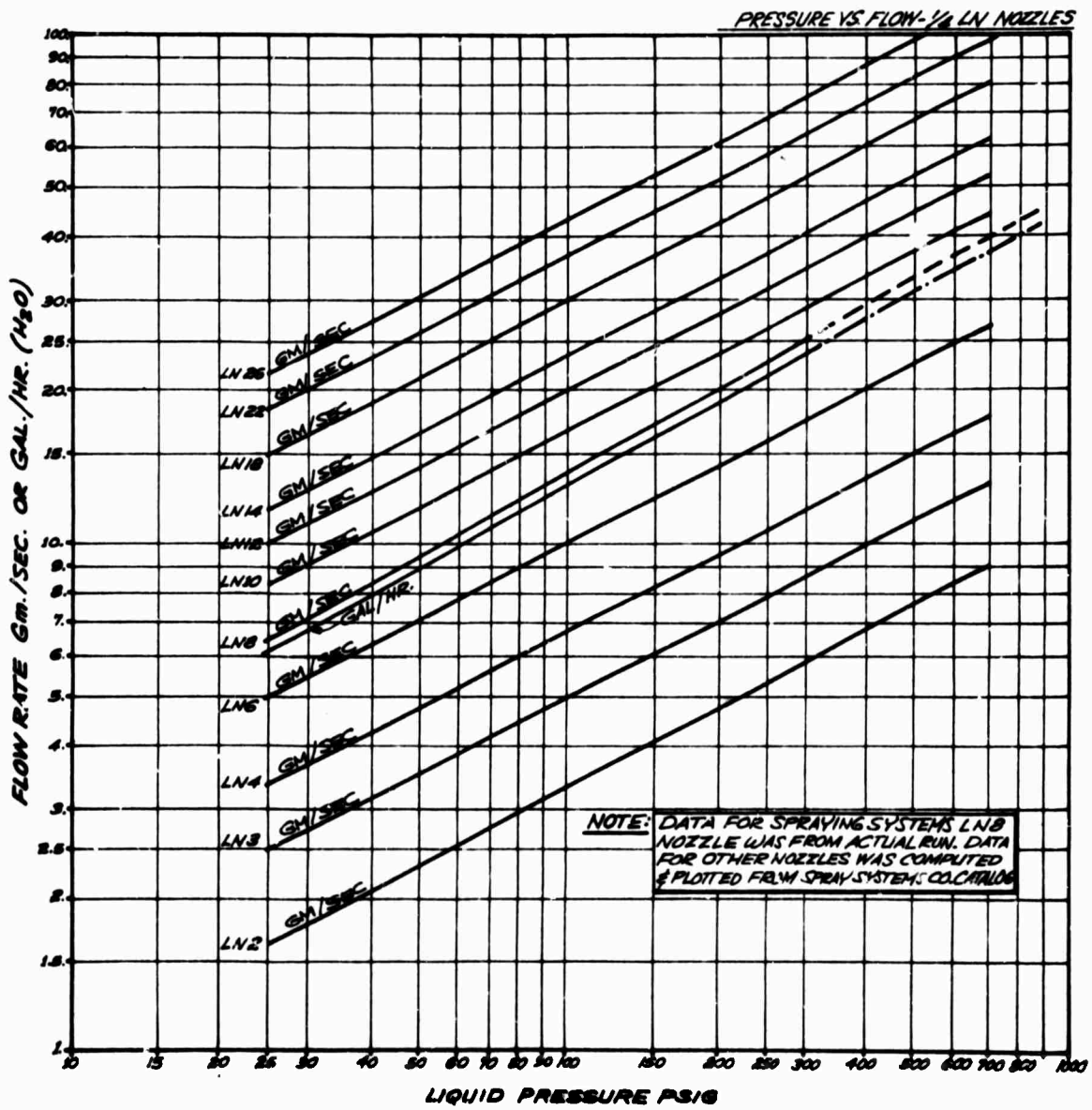

A-1982

FIGURE 23

FLOW RATE vs LIQUID PRESSURE FOR HOLLOW CONE NOZZLES (LN)

### 3.2.6 Accumulators (Cold Gas and Hot Gas).

Both cold gas and hot gas accumulators were used to store energy in the low pressure liquid tanks. The accumulator consisted of a piston that separated the liquid from the energizing gases. The cold gas systems were energized with dry nitrogen whereas the hot gas systems were energized by an electro-explosive squib and boron potassium nitrate propellant combination.

The relationship between the maximum accumulator pressure and the weight of boron potassium nitrate for a hot gas accumulator is defined by

$$PV = WRT \quad \text{where } RT = 1.3 \times 10^6 \frac{\text{ft-lb}}{\text{lb.}}$$

$$P = \frac{16.3W}{V}$$

W = WT Propellant (lb)

V = Vol accumulator (Cu. In.)

### 3.3 Tanks.

#### 3.3.1 General.

Tanks were categorized as low pressure (liquid) and high pressure (gas). Gaseous chemicals were carried in the payload at higher pressures than the liquids to achieve the desired loading densities. Two types of liquid tanks were provided, (1) baffled and (2) accumulator. Tank joints were either threaded, bolted, brazed or welded.

Materials of construction were aluminum and steel. Tanks were constructed to serve as the payload aerodynamic structural envelope. Low pressure tanks were configured with flat ends to save space and accommodate accumulator systems. Barium burner tanks had flat ends to facilitate chemical loading. Table 2 summarizes various tanks as to part number, material, configuration and working pressure.

#### 3.3.2 Structural Design.

Tanks were designed with a "burst" pressure two times the working pressure and were proof tested to at least 1.5 times the working pressure. During proof tests the tank dimensions were measured to determine if yielding occurred. Shapes used included: flat plate; 3:1 semi-major to semi-minor axis ellipsoid ends and cylinders. Wall thicknesses were determined by the following equations:

$$\text{Cylinder Thickness} = \frac{1.29 P_w D_i}{S_y}$$

$$\text{Ellipsoid (3 : 1) Thickness} = \frac{1.47 P_w D_i}{S_y}$$

$$\text{Flat Plate Thickness (Aluminum)} = \left( \frac{.475 P_w D_i^2}{S_y} \right)^{1/2}$$

$$\text{Flat Plate Thickness (Steel)} = \left( \frac{.59 P_w D_i^2}{S_y} \right)^{1/2}$$

Where  $P_w$  = Working Pressure

$D_i$  = Inside Diameter

$S_y$  = Yield Stress

The equations assume the "burst" pressure is the pressure at which the tank begins to yield. A factor of safety of 1.15 based on yield stress was also used. These equations are given in more detail in Appendix D. Table 2 summarizes the allowable working pressure of the various tanks as a function of material, wall thickness and shape.

### 3.3.3 Materials of Construction.

Aluminum was used for all low pressure tanks, whereas aluminum, carbon steel and stainless steel were used for high pressure tanks. The selection of tank materials was based on the following considerations:

1.           Compatibility with the chemicals to be contained,
2.           Availability (of raw stock),
3.           Ease of fabrication,
4.           Strength, relative to weight,
5.           Low temperature properties and,
6.           Cost.

Low temperature properties were considered since some gases are loaded by super-cooling the payload tank.

The cold temperature properties of aluminum are satisfactory whereas those of 4130 and 17-7 steel are poor as defined by shock sensitivity. But, in the case where the proper heat treat and stabilization cycles have been applied, these steels will regain satisfactory ductility after being warmed back to room temperature.

Aluminum is recommended for low pressure applications whereas 4130 steel is recommended for the high pressure systems due to relative availability of raw stock and ease of fabrication.

Since the payload chemicals are noncorrosive with aluminum and steel when contained in properly cleaned tanks, and storage time in flight tanks was relatively short, compatibility of tank material was not considered as a problem.

| Type   | Part No.         | Material         | Yield Stress (ksi) | Inside Dia. (in.) | End Type | End Wall Thick. (in.) | Cyl. Wall Thick. (in.) | Working Pressure (psi) | Volume (Cu. In) |
|--|------------------|------------------|--------------------|-------------------|----------|-----------------------|------------------------|------------------------|-----------------|
| Low Pressure Liquid (Accumulator - Cold Gas) | 308-36           | Aluminum 6061-76 | 35                 | 8.5               | Flat     | 0.625                 | 0.250                  | 400                    | 1400            |
| Low Pressure Liquid (Baffled)                | 299-34           | Aluminum 6061-76 | 35                 | 4.0               | Flat     | 0.437                 | 0.250                  | 875                    | 97              |
| Low Pressure Liquid (Accumulator - Hot Gas)  | 312-32           | Aluminum 6061-T6 | 35                 | 2.75              | Flat     | 0.500                 | 0.125 <sup>(3)</sup>   | 1230                   | 165             |
| High Pressure Gas                            | 277-43           | Aluminum 2024-T4 | 40                 | 7.75              | Ellipse  | 0.625                 | 0.500                  | 3000 <sup>(1)</sup>    | 2185            |
| High Pressure Gas                            | 349-22           | Stainless 17-7   | 185                | 8.68              | Ellipse  | 0.322                 | 0.160 <sup>(3)</sup>   | 2500                   | 1050            |
| High Pressure Gas                            | 355-60           | Steel 4130       | 155                | 7.5               | Ellipse  | 0.200                 | 0.125 <sup>(3)</sup>   | 1900                   | 1050            |
| High Pressure Gas                            | 309-24           | Steel 4130       | 86 <sup>(2)</sup>  | 4.250             | Flat     | 0.500                 | 0.250                  | 2540                   | 585             |
| High Pressure Gas                            | 319-39<br>333-34 | Steel 4130       | 86                 | 6.0               | Flat     | 0.625                 | 0.250                  | 1750                   | 150             |
| High Pressure Gas                            | 351-44           | Steel 4130       | 86                 | 8.0               | Flat     | 0.500                 | 0.094                  | 710                    | 3843            |
| High Pressure Gas                            | 363-33           | Steel 4130       | 86                 | 6.75              | Flat     | 0.438                 | 0.094                  | 890                    | 1282            |

NOTES: (1) Proofed to 4500 without yield  
(2) No heat treat  
(3) Stock sheet

TABLE 2  
TANK SUMMARY

### 3.3.4 Joints.

Threaded, bolted, brazed and welded joints have been used. The threaded joint consists of a screw-thread interface between the end cap and the cylinder whereas the bolted joint consists of a series of radial screws that attach the end to the cylinder. Figure 24 illustrates the tank joint designs. An advantage of the welded and brazed joints is that they provide an integral sealed structure whereas advantages of the threaded and bolted tanks are ease of fabrication and access to the inside for cleaning and installation of internal parts (i.e., piston, baffles.)

An aluminum tank with threaded joints was developed with 3000 psi working pressure. Figure 25 summarizes the effects of working pressure on tank radius, effective thread thickness and allowable force per thread. It can be noted that as the pressure increases, the effective thread thickness is decreased as a result of tank expansion and therefore, the allowable force per thread decreases with pressure.

### 3.3.5 Seals.

Seals were required for the threaded and bolted joint tanks. Major considerations during seal design were

1. Compatibility with working fluid,
2. Operating pressures,
3. Operating temperatures (Cryogenic and high temperature).

Two types of seals were used, (1) metal to metal (37° flare and flat face), (2) O-ring. O-ring seal designs used available off-the-shelf O-rings. Metal-to-metal seals were used on plumbing and rupture disc nozzle attachments to tanks whereas tank end cap and cylinder joints used O-rings. Dynamic O-ring seals were used to seal accumulator pistons.

Figure 25 illustrates the various tank seal designs used. For compatibility Viton A was used for TMA applications. Teflon was compatible with Nitric Oxide, but was difficult to provide a tight seal (277-43). Buna N provided the resilience and high temperature qualities required for the barium burner applications. O-ring seals are not compatible with low temperature applications (0°C or less).

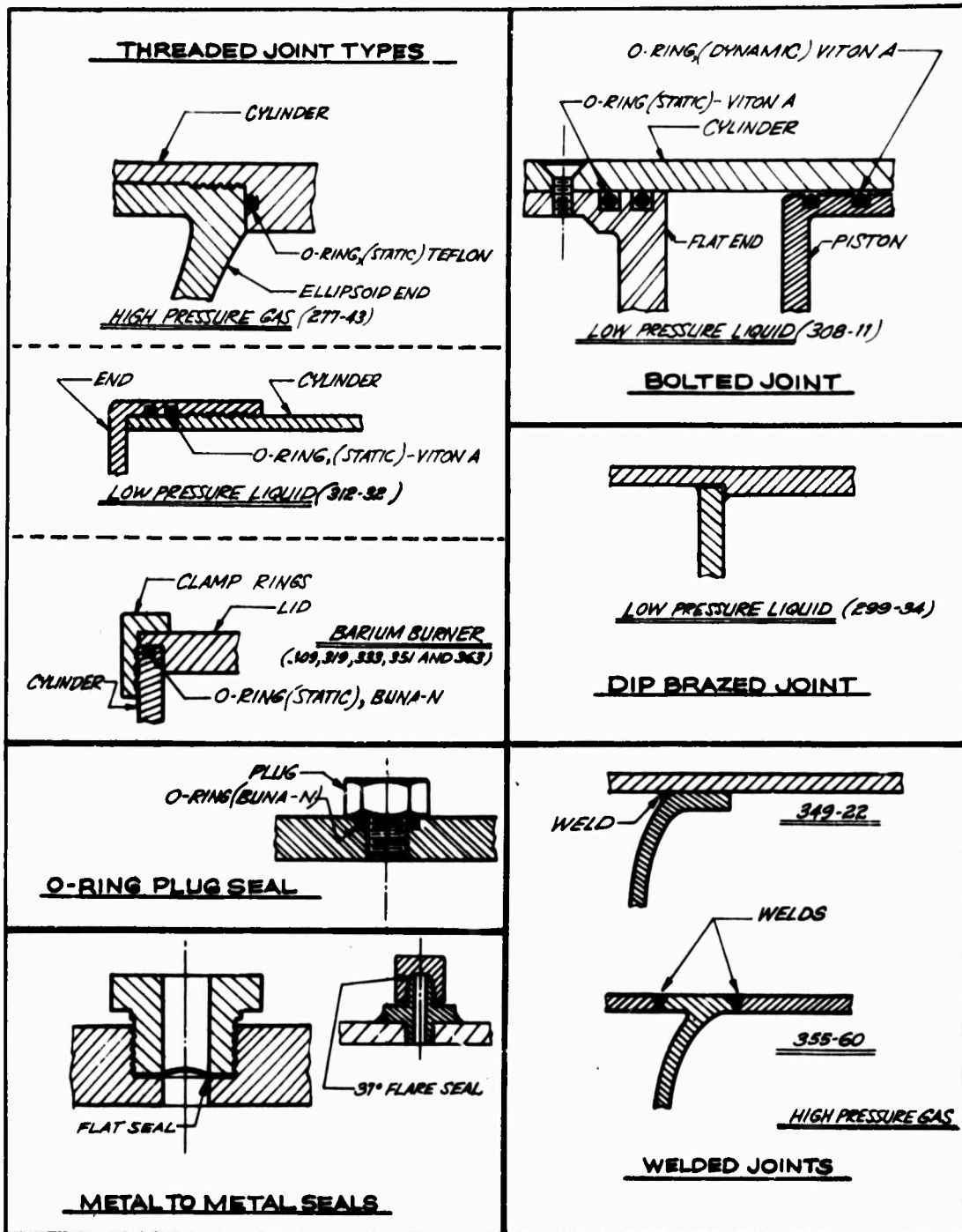

A-1984

FIGURE 24 TANK JOINTS AND SEALS

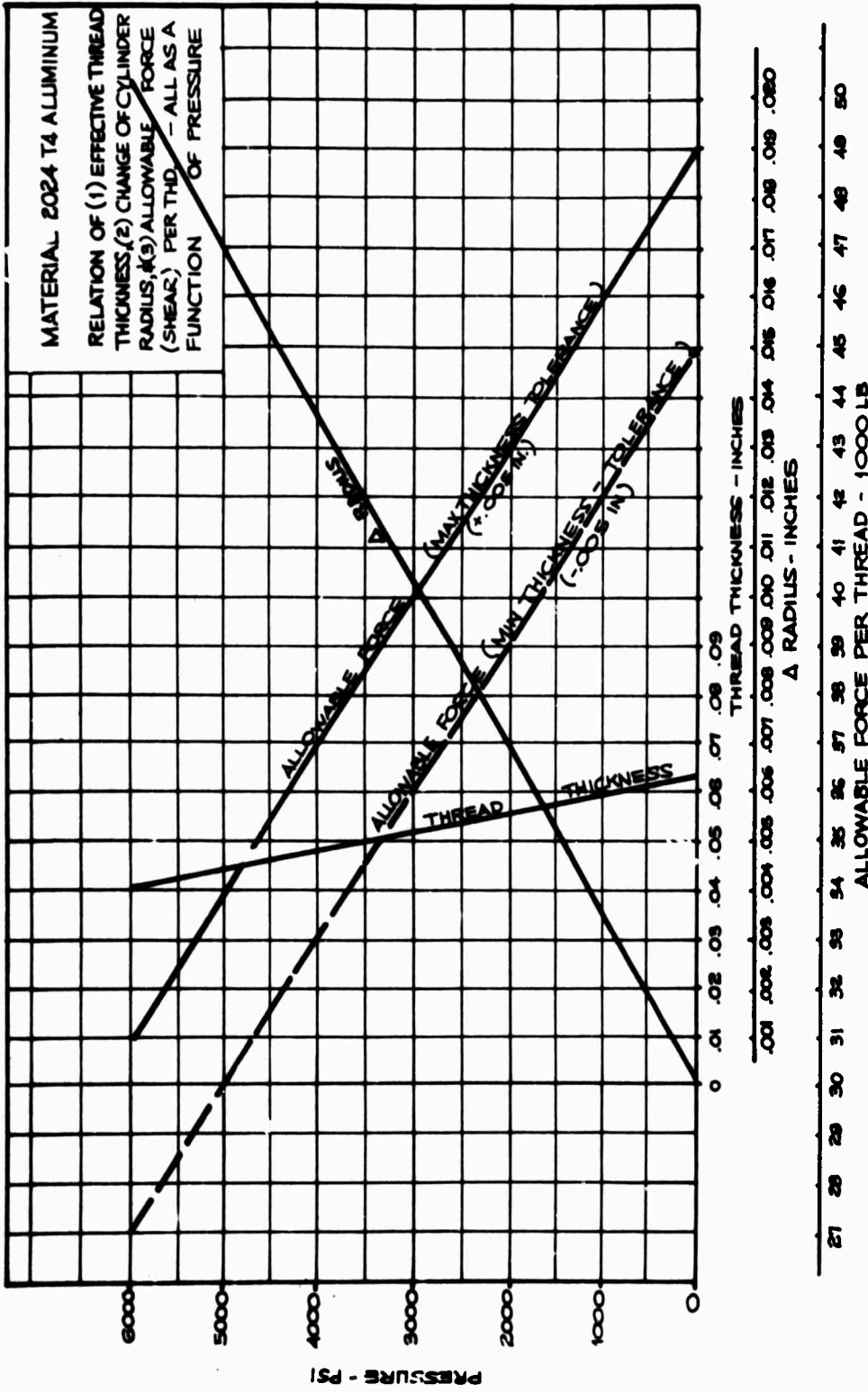

FIGURE 25  
 ALLOWABLE FORCE PER THREAD vs WORKING PRESSURE  
 ALUMINUM TANK 277-43

A-1985

### 3.4 Programmers.

#### 3.4.1 General.

Programmers initiated an event or a series of events at predetermined times after rocket launch.

The basic programmer consisted of a Raymond Engineering spring wound "G" activated timer, Yardney PM-1 or HR-1 dry charge battery power supply and two safing devices.

To commit and continue to run, the timer must experience 5 "G"s for at least one percent of its maximum time capacity (i. e., 180, 300, 500 or 600 seconds.) Timer setting involved adjustment of a "setting arm" on the single switch model and cams on the multi-switch model. Timer switch closure (SPDT) initiated the desired event(s).

The safing devices included an arm/short device and timer lock. An arm/short receptacle accommodated either an arming or shorting connector. The shorting connector isolated the electro-explosive device(s) (EED's) from the power supply portion of the programmer and shorted the EED leads. The arming connector connected the EED leads to the power supply portion of the programmer, thus arming the programmer leaving the timer switch to complete the circuit between the batteries and the EED's.

A timer lock pin physically would not allow the timer to run.

Access doors were provided to the arm/short connector as well as to the timer, allowing last minute battery voltage and EED continuity checks, timer visual inspection checks, timer lock pin removal and arm/short functions.

#### 3.4.2 Single Event Programmer.

Figure 26 and 27 are electrical schematics for the single event programmer with a single EED and a dual EED respectively.

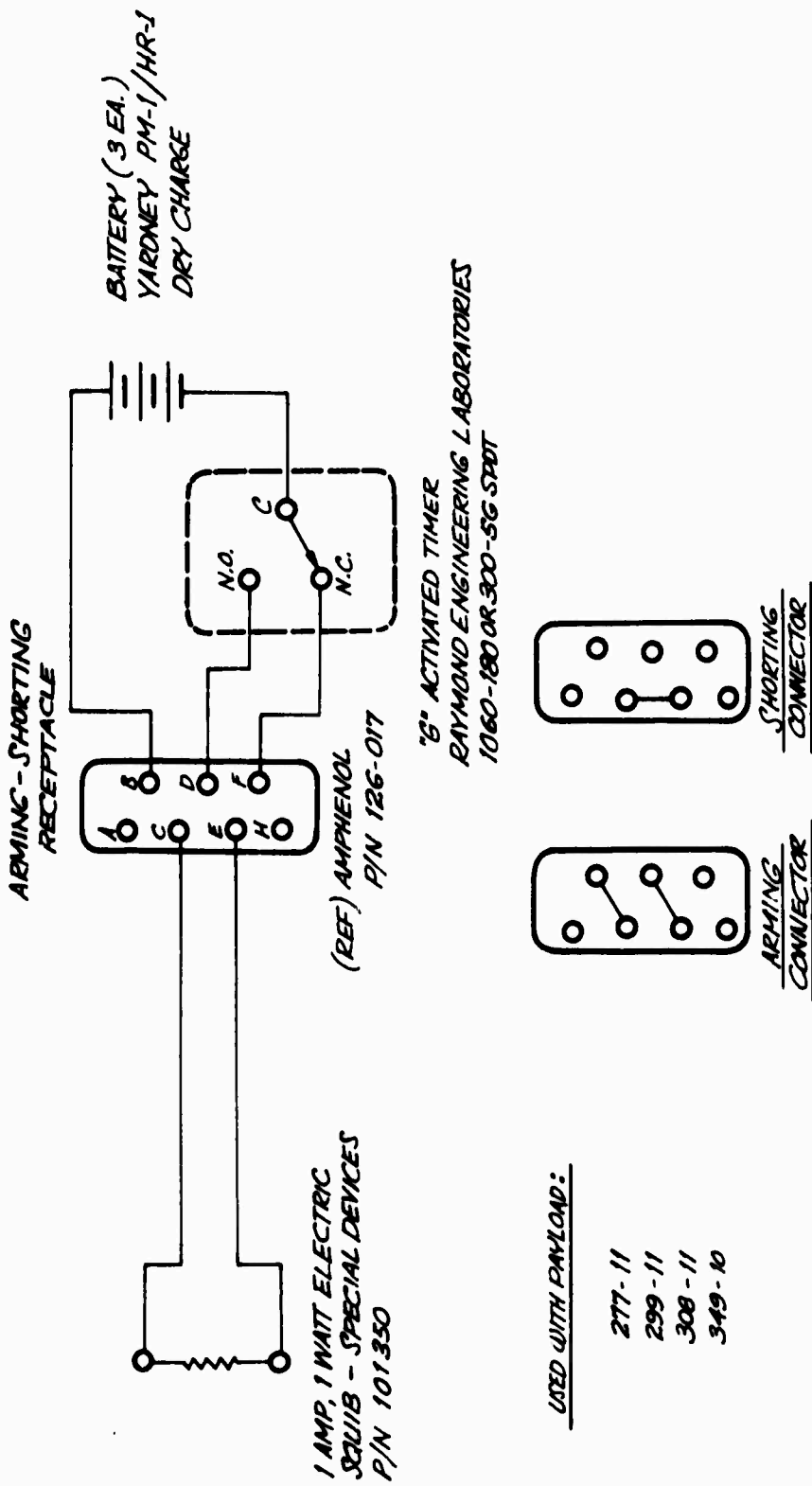
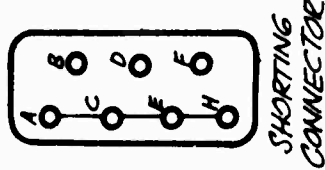
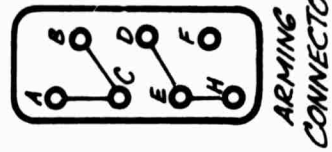
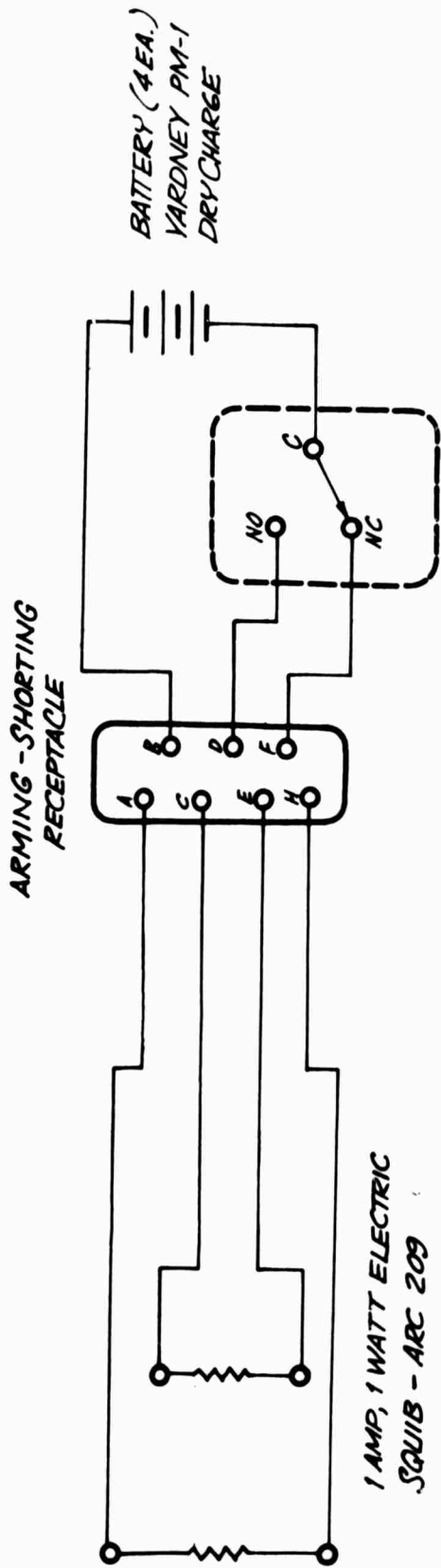

FIGURE 26 ELECTRICAL SCHEMATIC 277-44 SINGLE EVENT PROGRAMMER - SINGLE EED

A-1986



USED WITH PAYLOADS:

- 278 - 11
- 309 - 11
- 319 - 12
- 333 - 12
- 351 - 10
- 363 - 10

FIGURE 27

ELECTRICAL SCHEMATIC (278-35) SINGLE EVENT PROGRAMMER - DUAL EED

A-1987

### 3.4.3 Multi-Event Programmer.

Figure 28 is an electrical schematic for a three event programmer. This programmer was very similar to the single event type except the multi-event programmer contained a multi-switch Raymond timer. Each switch being a cam-operated micro-switch.

Two techniques were used to initiate multi-events, (1) a separate battery power supply was provided for each event as shown in Figure 28, (2) a single power supply was provided for all events as shown in Figure 29. Fusistars were added to all but the last EED circuit to preclude shorting the battery in case the EED's shorted upon firing.

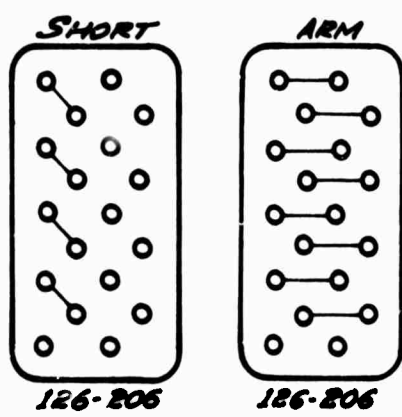
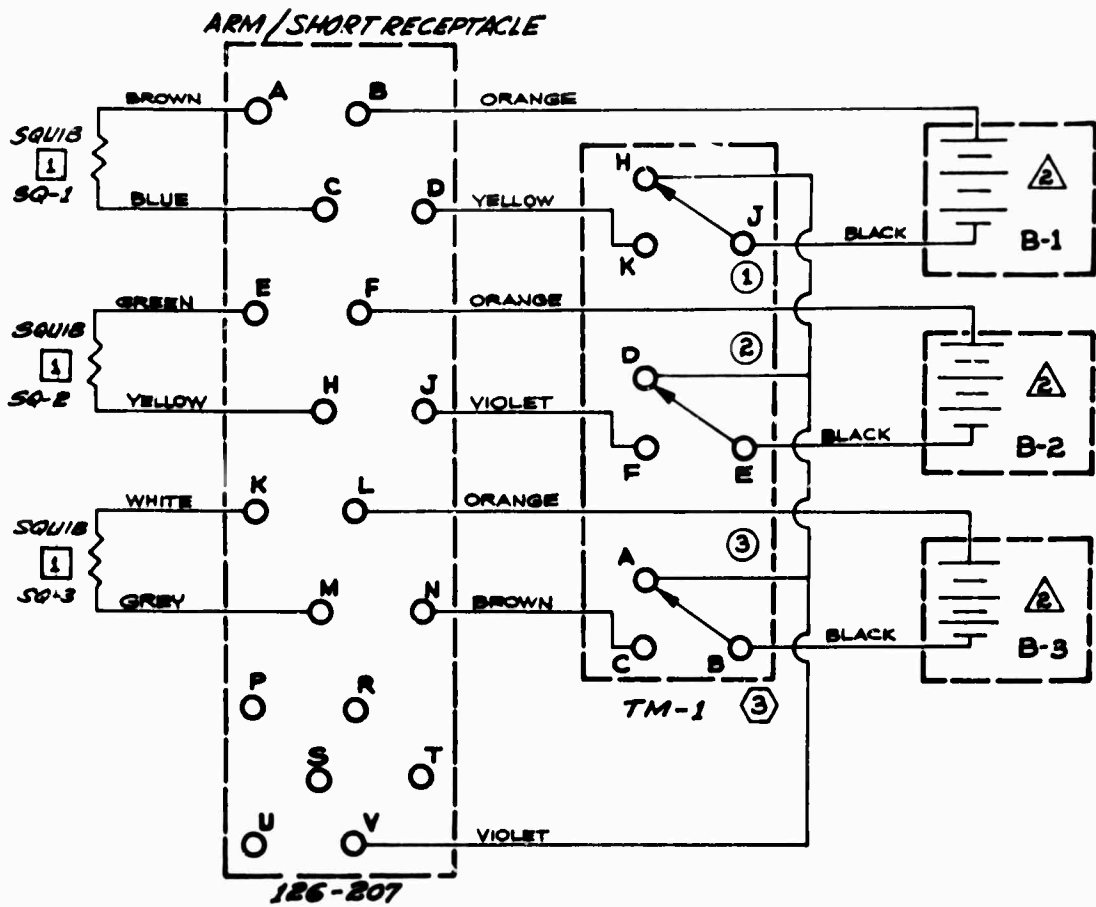

- ③ RAYMOND 1060-300T 3SPDT WITH 1% ARM
- ⚡ YARDNEY PM1-B BATTERY (3 EACH)
- ① ARC 209 1 AMP, 1 WATT, 5 MIN.

TIMER  
 SW 1 H-J OPENS, J-K CLOSES  
 SW 2 D-E OPENS, E-F CLOSES  
 SW 3 A-B OPENS, B-C CLOSES

BARILUM 3-BURNER PAYLOAD 309-12

FIGURE 28  
 ELECTRICAL SCHEMATIC (309-28) THREE EVENT PROGRAMMER

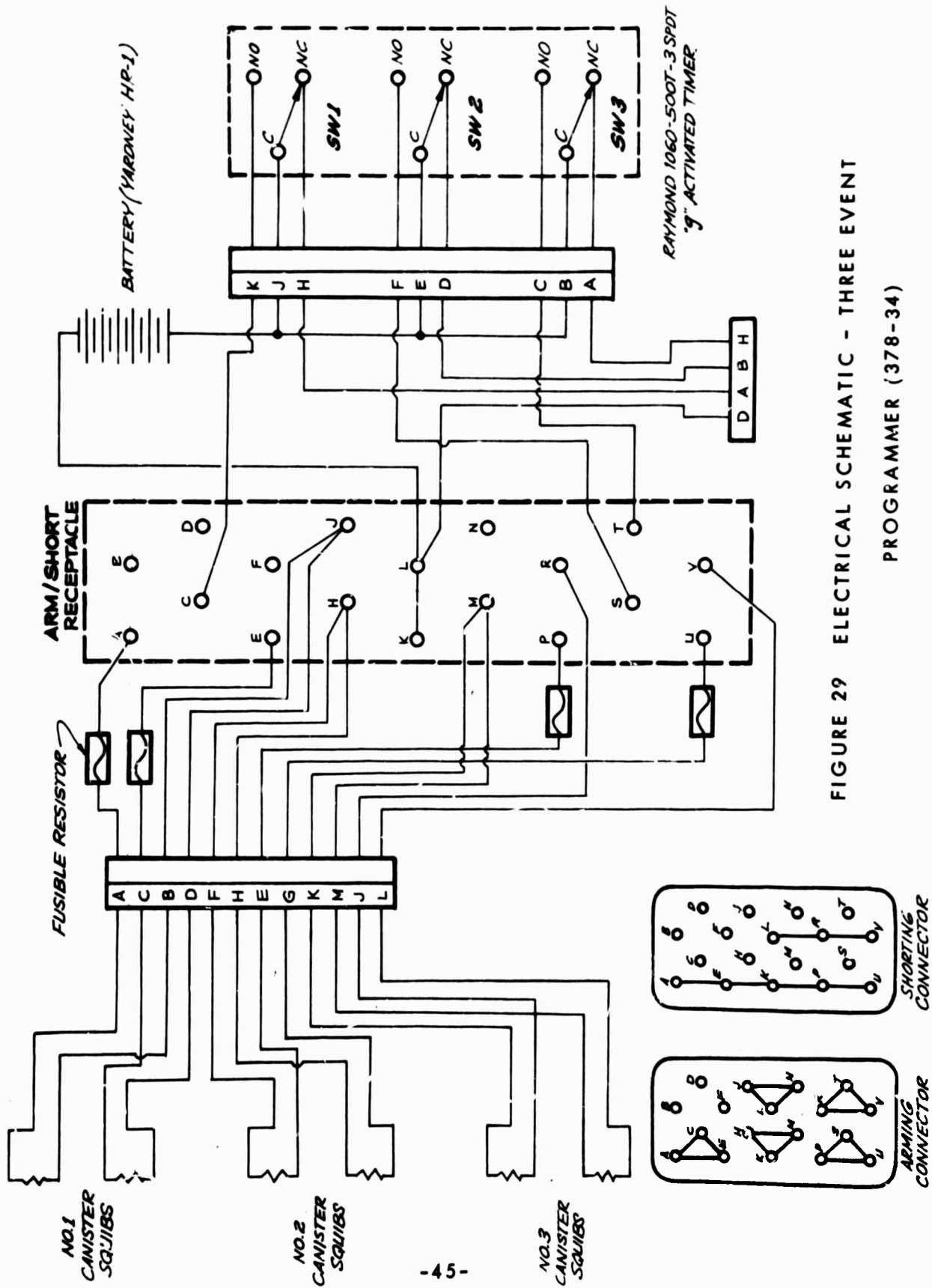

#### 3.4.4 Multi-Event Programmer with Valve Sequencer.

This programmer was similar to the multi-event programmer, except the arm/short was eliminated, since inadvertant functioning of the programmer would not cause a safety hazard. Also, two electronic valve sequencers (372-10) were added to pulse the solenoid valve (s) giving two release sequences over the same trajectory. Figures 30 and 31 are electrical schematics for the 322-11 and 371-10 systems respectively.

The valve sequencer consisted of two (2) R-C relaxation oscillators and is schematic-ally illustrated in Figure 32. The duty cycle time is defined by a variable resistor,  $R_L$  and capacitor,  $C_L$ , whereas the solenoid valve pulse time is defined by variable resistor  $R_S$  and capacitor,  $C_S$ . A typical pulse profile of the sequencer is graphically illustrated in Figure 33.

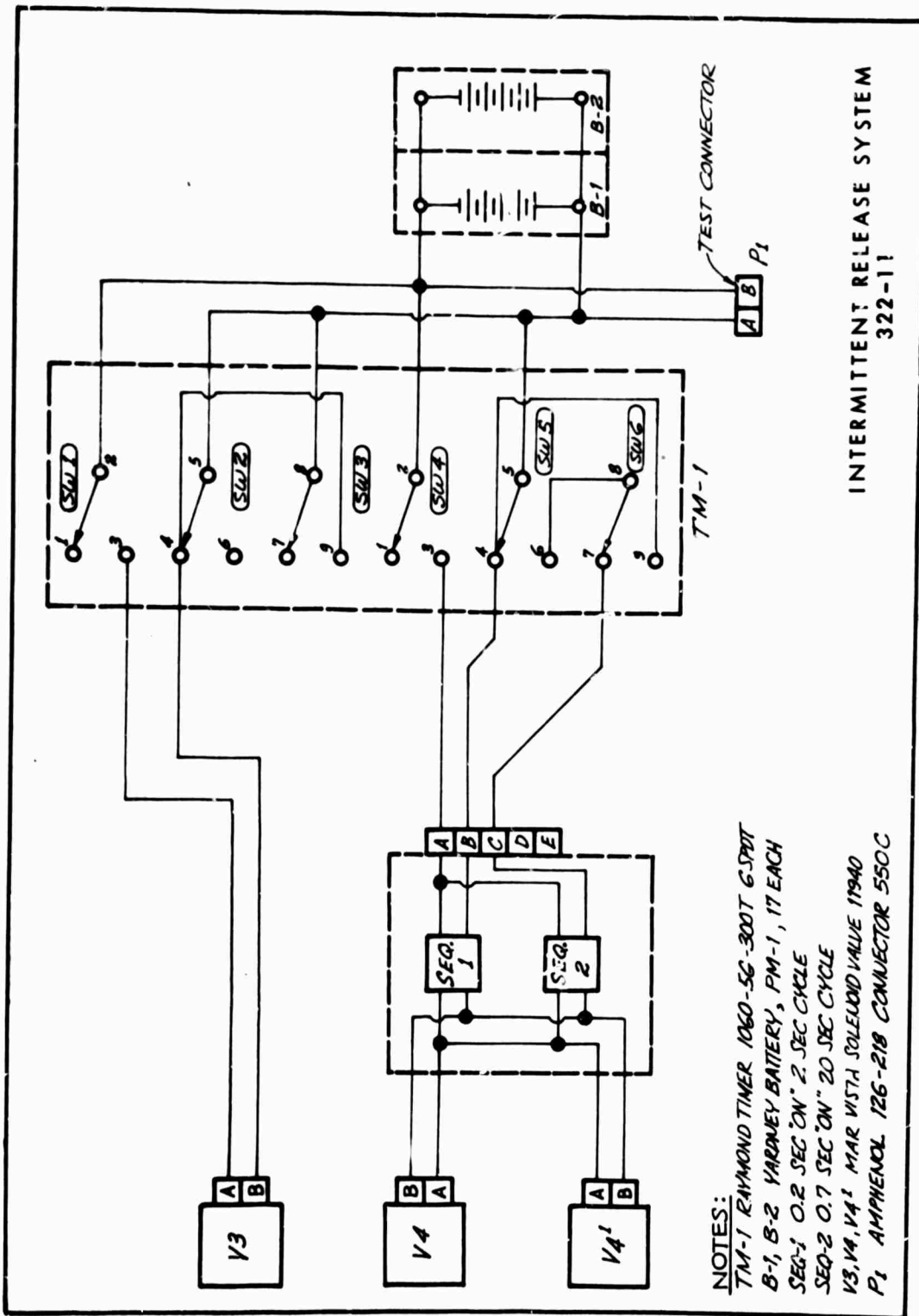

FIGURE 30 ELECTRICAL SCHEMATIC (284-214) THREE EVENT PROGRAMMER WITH VALVE SEQUENCER

A-1990

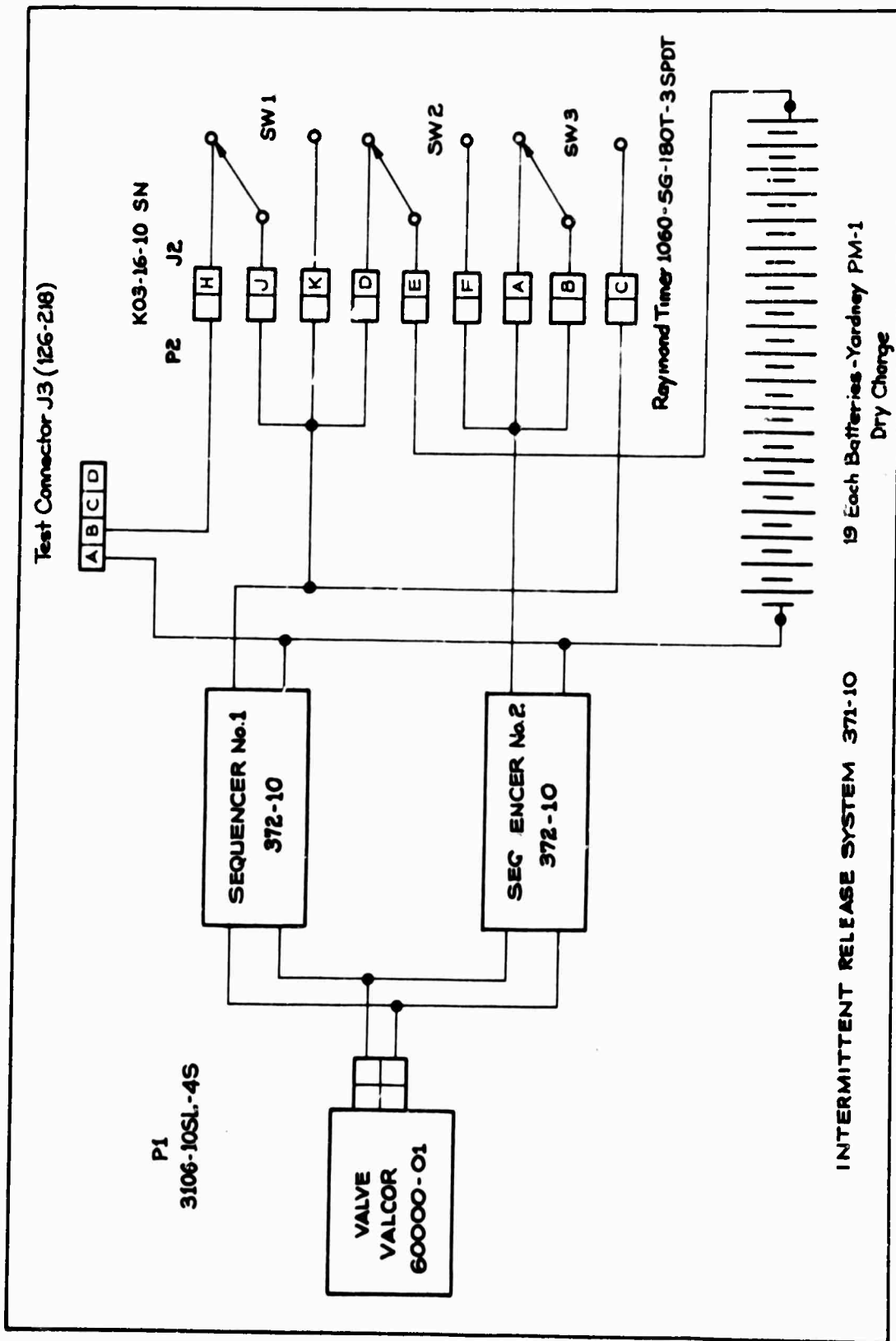
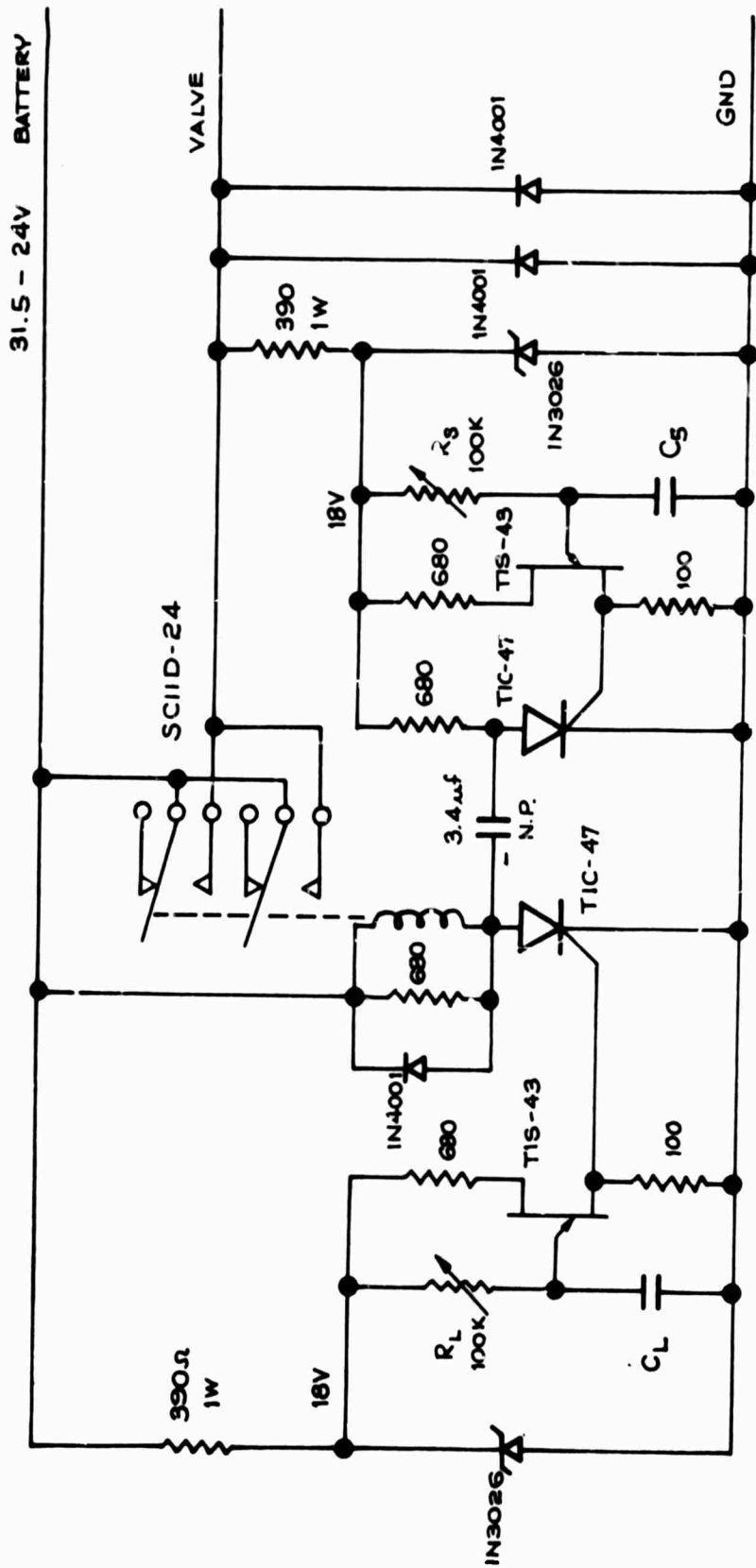

FIGURE 31 ELECTRICAL SCHEMATIC (371-23) MULTI EVENT PROGRAMMER WITH VALVE SEQUENCER  
A-1991



Regulator Effective 31.5 V - 22.5 V

FIGURE 32 ELECTRICAL SCHEMATIC (372-21) VALVE SEQUENCER

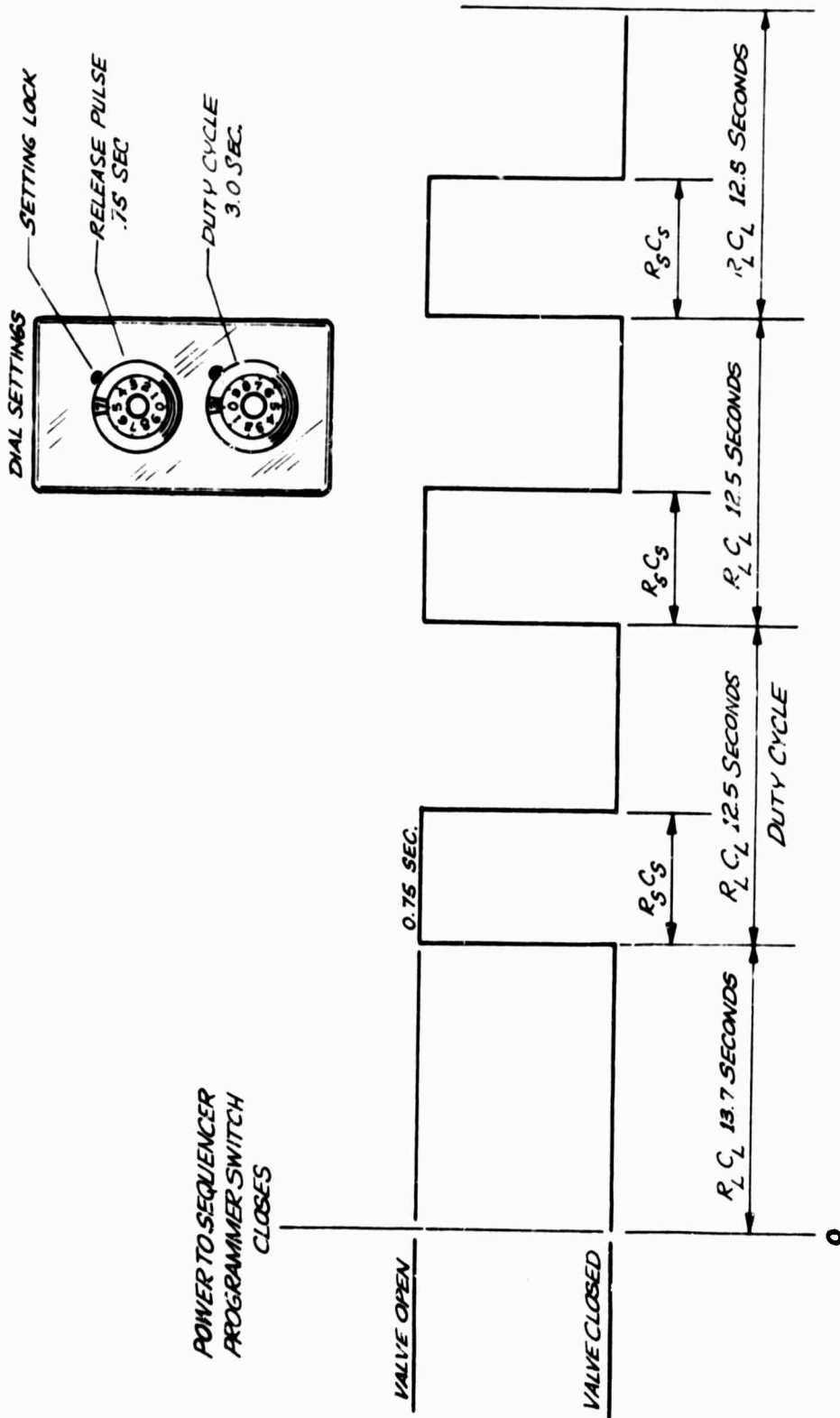
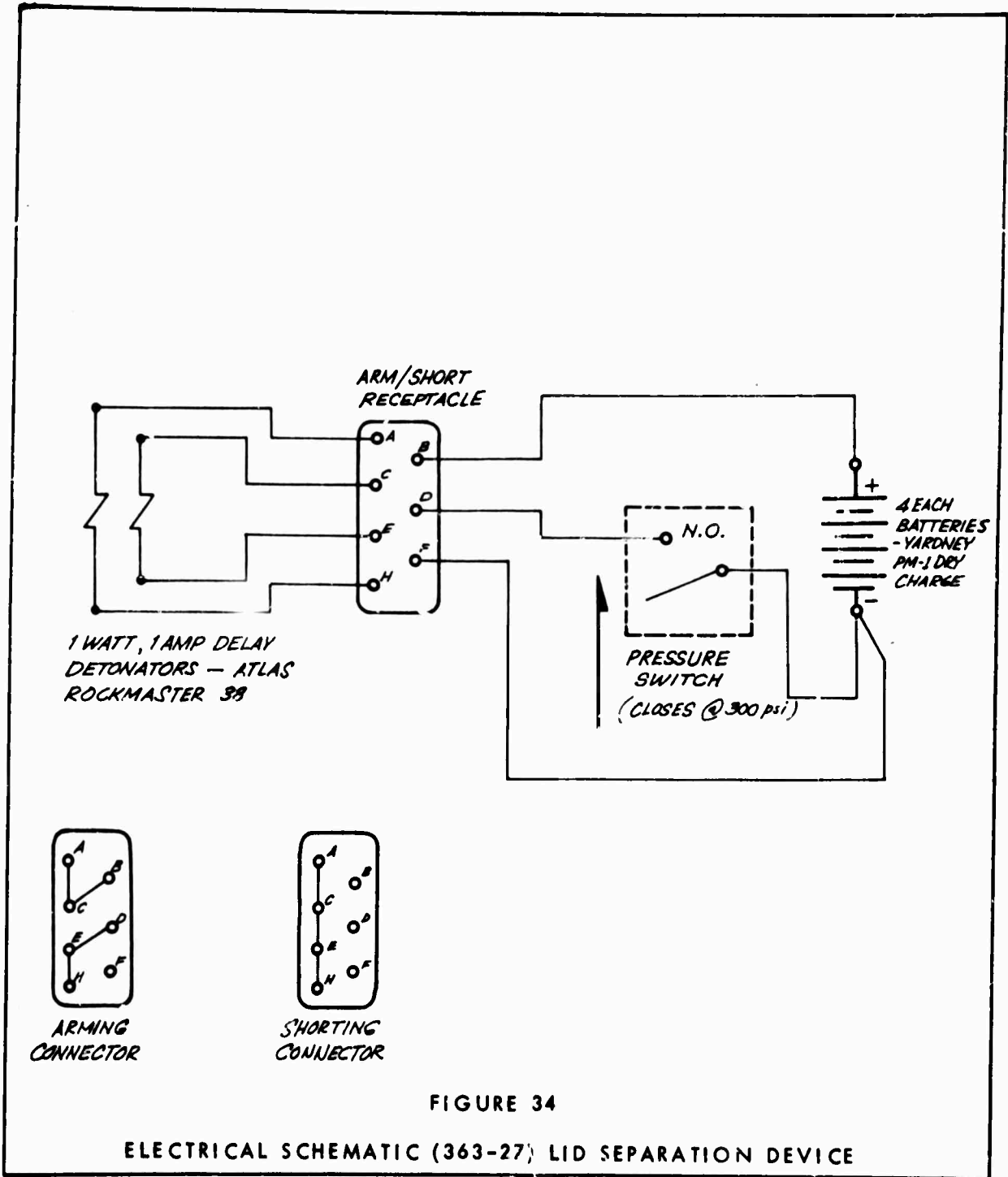

FIGURE 33  
TYPICAL PULSE PROFILE - VALVE SEQUENCER (372-10)

#### 3.4.5 Lid Separation Device.

A lid separation device was developed for the delayed release Barium burner systems (352-10 and 363-10 , Sect. 3.5). This device was identical to the single event programmer described in Section 3.4.2, except that the timer was replaced with a pressure switch that monitored the Barium burner pressure. The pressure switch closed at 300 PSI completing the circuit to the lid separation EED's. This device is schematically illustrated in Figure 34.



A-1993

#### 3.4.6 Pyro Delay (EED).

This was the simplest programming method used (payload 361-10) and consisted of electrically initiating a 1 amp, 1 watt no-fire pyro delay EED at launch.

#### 3.5 Barium Burner.

##### 3.5.1 General.

Six barium burner configurations were provided containing a minimum of 5.3 pounds (2.4 Kg) net and a maximum of 48 pounds (21.9 Kg). Two types of burners were provided; (1) those giving instantaneous release upon ignition through rupture disc nozzle(s) and (2) those giving a delayed release by cutting the lid from the tank a finite time after burner ignition. Figure 35 illustrates these various barium burner configurations.

A series of ground tests were conducted to verify burner structural design and to determine burning properties of different formulations at various loading densities and pressures. Burning properties investigated included, (1) reaction energy, (2) burn pressure, (3) vent time, (4) flame temperature, (5) burn time and (6) thrust. Table 3 gives the formulations tested and used for flight. Certain tests were instrumented with pressure, acceleration and temperature monitors. Tests are detailed further in Appendixes F through I.

The barium/copper oxide composition was press loaded into the burner (309, 319, 333) or into a metal sleeve which was then inserted into the burner (351 and 363). All barium handling was conducted in either a kerosene or argon atmosphere.

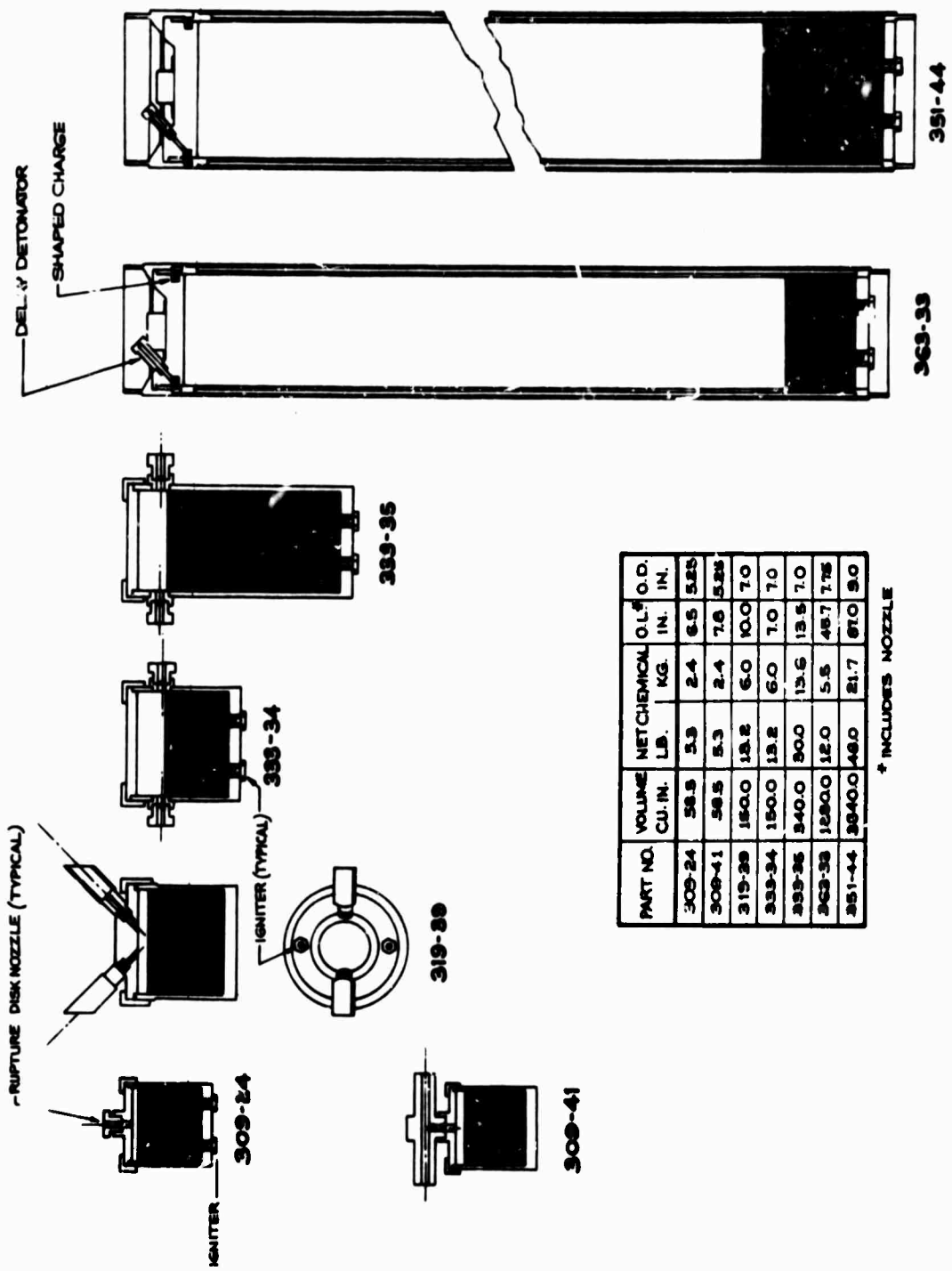

| PART NO. | VOLUME<br>CU. IN. | NET CHEMICAL |      | O.L.* O.D. |      |
|----------|-------------------|--------------|------|------------|------|
|          |                   | LB.          | KG.  | IN.        | IN.  |
| 309-24   | 58.5              | 5.3          | 2.4  | 6.5        | 5.85 |
| 309-41   | 58.5              | 5.3          | 2.4  | 7.6        | 5.85 |
| 319-39   | 150.0             | 13.2         | 6.0  | 10.0       | 7.0  |
| 333-34   | 150.0             | 13.2         | 6.0  | 7.0        | 7.0  |
| 363-36   | 340.0             | 30.0         | 13.6 | 13.5       | 7.0  |
| 363-33   | 1290.0            | 12.0         | 5.5  | 45.7       | 7.75 |
| 351-44   | 2840.0            | 48.0         | 21.7 | 87.0       | 9.0  |

\* INCLUDES NOZZLE

FIGURE 35 BARIUM BURNER CONFIGURATION SKETCHES

A-1994

### 3.5.2 Burner Hardware

Each barium burner consisted of a tank, (canister) with chemical, igniter (s), and venting system. Tanks were constructed of 4130 steel with a removeable lid to facilitate loading the charge into the burner.

The igniter consisted of a 1 amp, 1 watt, no-fire electro-explosive squib, (ARC209 or SDI 101350) mounted in a threaded plug located in either the top or bottom lid of the burner. Initially a single igniter was located in the removeable lid, but as a result of requirements for void volume variations of the burner in the top of the burner and high ignition reliability, dual igniters were placed in the bottom.

In certain cases it was necessary to place a filler in the burner void volume to keep the barium charge from shifting. Originally a styrofoam filler was used, but this adversely affected the optical data, therefore a light-weight sheet metal clamp was adapted.

The nozzle venting systems used a 1500 psi nominal rupture disc to seal the burner prior to ignition and venting. Both single and dual nozzle systems were used. Nozzles were positioned as shown in Figure 35.

Dual nozzles were diametrically positioned so that burner venting would not produce torques to upset the vehicle during flight. A T nozzle was also used with the single nozzle configuration to minimize upsetting torques.

The lid separation venting system gave instantaneous delayed release. Upon barium burner ignition, burning pressure closed a pressure switch in the lid separation programmer (section 3.4.5) firing a delay-detonator (0.25 sec) that in turn detonates a shaped charge, cutting the tank circumferentially. Figure 36 illustrates the lid separation venting system.

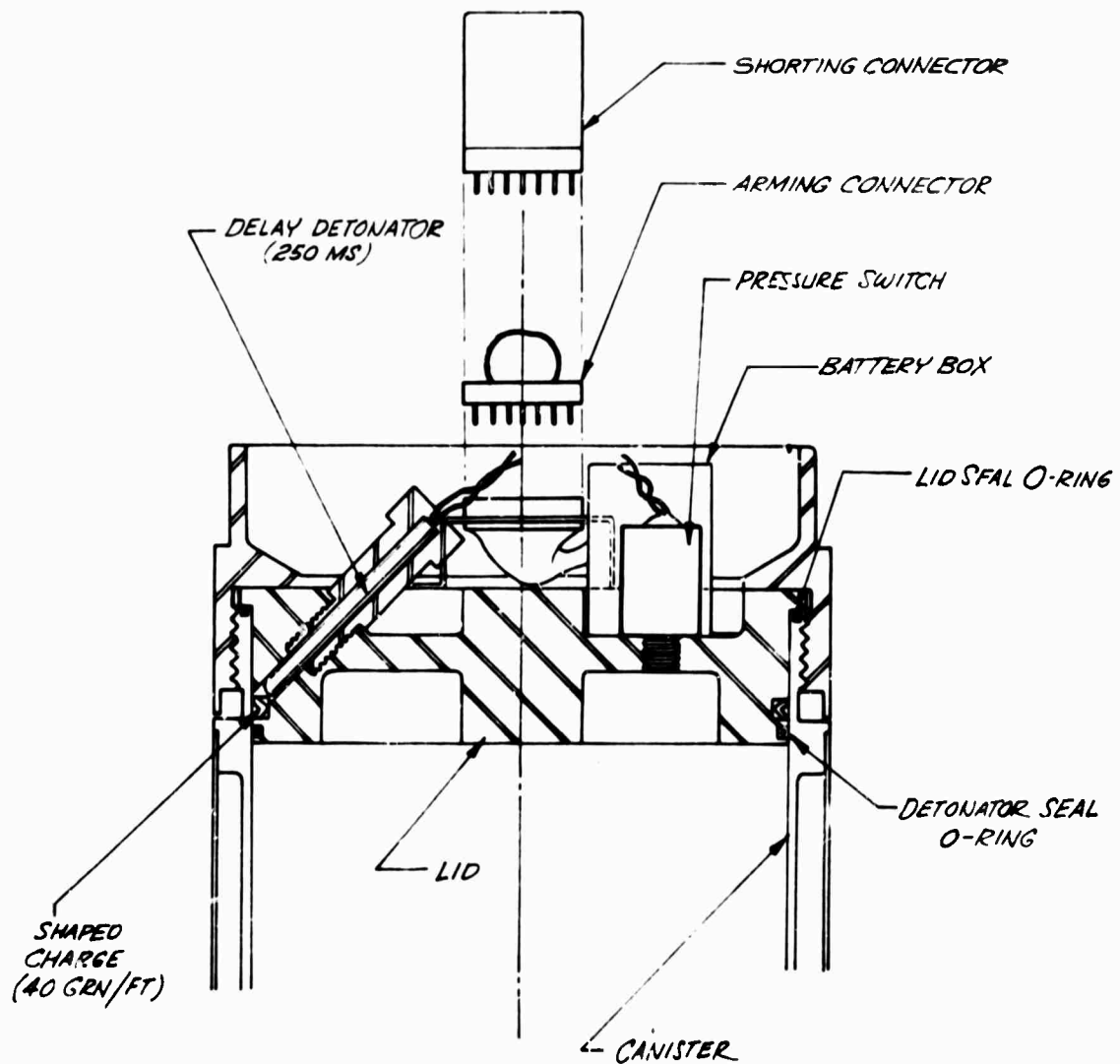

FIGURE 36

LID SEPARATION SYSTEM - BARIUM BURNER (363-10, 351-10)

### 3.5.3 Chemicals.

Various formulations of barium and copper oxide and, in certain cases, additives of beryllium, strontium or sodium were blended and press-loaded directly into the burners. The barium, strontium and sodium were used in granular form of 1 to 3 millimeters, whereas the copper oxide was 200 mesh. Table 3 gives the various formulations tested and provided in flight systems. Section 4.5 describes the barium burner chemical handling.

### 3.5.4 Tests.

3.5.4.1 Structural Tests (Nozzles and Tank). Rupture disc nozzles were tested to verify rupture disc failure and determine erosion effects of the barium burner reaction products. Erosion tests were also run with graphite nozzles. Steel rupture disc nozzles with 0.5 inch diameter port enlarged to approximately 0.6 inch diameter in the 309, 319 and 333 configurations. Burn tests to determine the effects of nozzle erosion on thrust unbalance, gave no adverse results - unbalanced thrusts were not large enough to upset the vehicle. Detailed nozzle erosion tests results are presented in Appendix F.

Tank structural tests were run by first pressure checking the tank to the expected operating pressure, loading and firing the burner closed (no vents) and checking the tank after firing for structural failure. During these firings burn through did occur a minimum of 9 seconds after ignition. Since vent time was on the order of 0.3 seconds, the design was considered conservative. During calorimeter tests (Section 3.4.5.2) with the 309-24 burner fired in water - no burn through occurred.

3.5.4.2 Energy. Calorimeter tests indicated that approximately 823 K calories were produced by the reaction of 2400 grams of the 75% Ba, 25% CuO mixture ("A" mix). Attempts to measure the energy output of the "E" mixtures were unsuccessful. Detailed results of these tests are given in Appendix G.

3.5.4.3 Pressure. Numerous tests were run to determine Ba burner pressure. Table 4 lists the results of tests conducted with closed burners, although it should be noted that the vented and non-vented system produced the same maximum initial pressures. Also, during initial testing, higher than expected pressures (i.e., 4000 psi) were recorded. These high pressures were attributed to the presence of kerosene or benzene residuals from the preparation process. Therefore, cleaning procedures were refined to eliminate residual hydrocarbons and pressures for the same system using the refined washing methods were recorded at approximately 2300 psi maximum. Additional pressure test data are given in Appendix H and I.

| <u>Mix</u> | <u>Formulation</u>                           |
|------------|--|
| A          | 75% Barium (Ba)<br>25% Copper Oxide (CuO)    |
| As         | 75% Ba<br>25% CuO<br>8-20 gms Strontium (Sr) |
| An         | 75% Ba<br>25% CuO<br>24-60 grams Sodium (Na) |
| B          | 63.5% Ba<br>36.5% CuO                        |
| C          | 68.5% Ba<br>31.5% CuO                        |
| D          | 90% CuO<br>10% Beryllium (Be)                |
| E          | 27% Ba<br>65% CuO<br>08% Be                  |
| F          | 43% Ba<br>53% CuO<br>04% Be                  |
| G          | 70% Ba<br>30% CuO                            |
| H          | 69% Ba<br>31% CuO                            |

BARIUM BURNER CHEMICAL FORMULATIONS

TABLE 3

| (1)(3)<br>Model S/N | Mix | Chemical Wt.<br>(Grams) | Loading<br>Pressure<br>(psi) | Burner Volume<br>(Cu. In.) | Maximum<br>Burning Pressure |
|---------------------|-----|-------------------------|------------------------------|----------------------------|-----------------------------|
| 309-22              | A   | 1000                    | 2130                         | 23.3                       | 2000 psi                    |
| 309-32              | A   | 2400                    | 10,000                       | 58.5                       | 3420 psi                    |
| 309-33              | B   | 2540                    | 2130                         | 58.5                       | 2660 psi                    |
| 309-34              | C   | 2470                    | 2130                         | 58.5                       | 2620                        |
| 309-35              | A   | 2400                    | 2130                         | 58.5                       | 1920                        |
| 309-37              | E   | 2740                    | 2130                         | 58.5                       | 3290                        |
| 309-38              | F   | 2490                    | 2130                         | 58.5                       | 2150                        |
| 309-39              | A   | 2400                    | 2130                         | 58.5                       | 2330                        |
| 309-47              | A   | 2400                    | 2130                         | 58.5                       | 2000                        |
| 309-48              | A   | 2400                    | 6800                         | 58.5                       | 1800                        |
| 309-49              | G   | 260                     | 2130                         | 58.5                       | 780                         |
| 309-50              | G   | 260                     | 8500                         | 58.5                       | 860                         |
| 309-51              | G   | 130                     | 2130                         | 58.5                       | 460                         |
| 309-52              | G   | 520                     | 2130                         | 58.5                       | 1420                        |
| 319-4               | A   | 6000                    | 2130                         | 150                        | 2000                        |
| 333-14              | A   | 1774                    | 2130                         |                            | 780                         |
| 363-3               | G   | 355                     | 2130                         | 39                         | 1620                        |
| 363-4               | G   | 355                     | 2130                         | 39                         | 1570                        |
| 363-5               | G   | 355                     | 2130                         | 39                         | 1550                        |
| 363-6 (2)           | G   | 324                     | 2130                         | 58.5                       | 875                         |
| 363-7               | G   | 1830                    | 2130                         | 322                        | 875                         |
| 363-8               | H   | 2775                    | 2130                         | 641                        | 875                         |

(1) Models 309-24, 319-39, 333-34 and 363-33

TABLE 4  
BARIUM BURNER PRESSURE SUMMARY

3.5.4.4 Vent Time. Vent time for the 2.4 Kg single nozzle (309-24) and the 6 Kg dual nozzle (319-39, 333-34) systems were nominally 0.3 seconds whereas the vent time for the lid systems was instantaneous.

3.5.4.5 Flame Temperature. Flame temperature tests were run with the 5.3 pound (2.4 Kg) and the 13.3 pound (6 Kg) burners. Results indicated flame temperatures above 6000°F, since the melting temperature of the thermocouple (Tungsten/Rhenium) is 6000°F and the thermocouple melted during the reaction. Flame temperature was recorded to 5400°F.

3.5.4.6 Burn Time. Attempts were made to measure burn time in the 2.4 Kg and 6 Kg burners. Initially the charge was considered to be an end burner and burn time was considered to be the time of initial pressure rise at the ignition end of the burner to the time a thermistor burned out at the opposite end of the can. Tests showed time inconsistencies that indicated the system was not acting as an end burner, but that in some cases the flame was propagating through and around the sides of the charge. Pressure traces indicated possible irregular burning since some traces gave a smooth pressure rise to a maximum pressure whereas others gave an instantaneous pressure rise indicating fragmentation of the thermite.

For a closed system, burn time could be assumed to be the time during which pressure rises indicating burning and heating of the gas within the tank. Typical burn time based on this assumption ranged between 10 and 300 ms.

3.5.4.7 Thrust. Thrust was determined for a 6 Kg burner by measuring the acceleration of the burner along the thrust axis which was 45° from the thrust line of each of two nozzles (a model 319 burner) giving a maximum thrust of approximately 3200 pounds, approximately 250 milliseconds after ignition. Figure 3/ illustrates the thrust set-up.

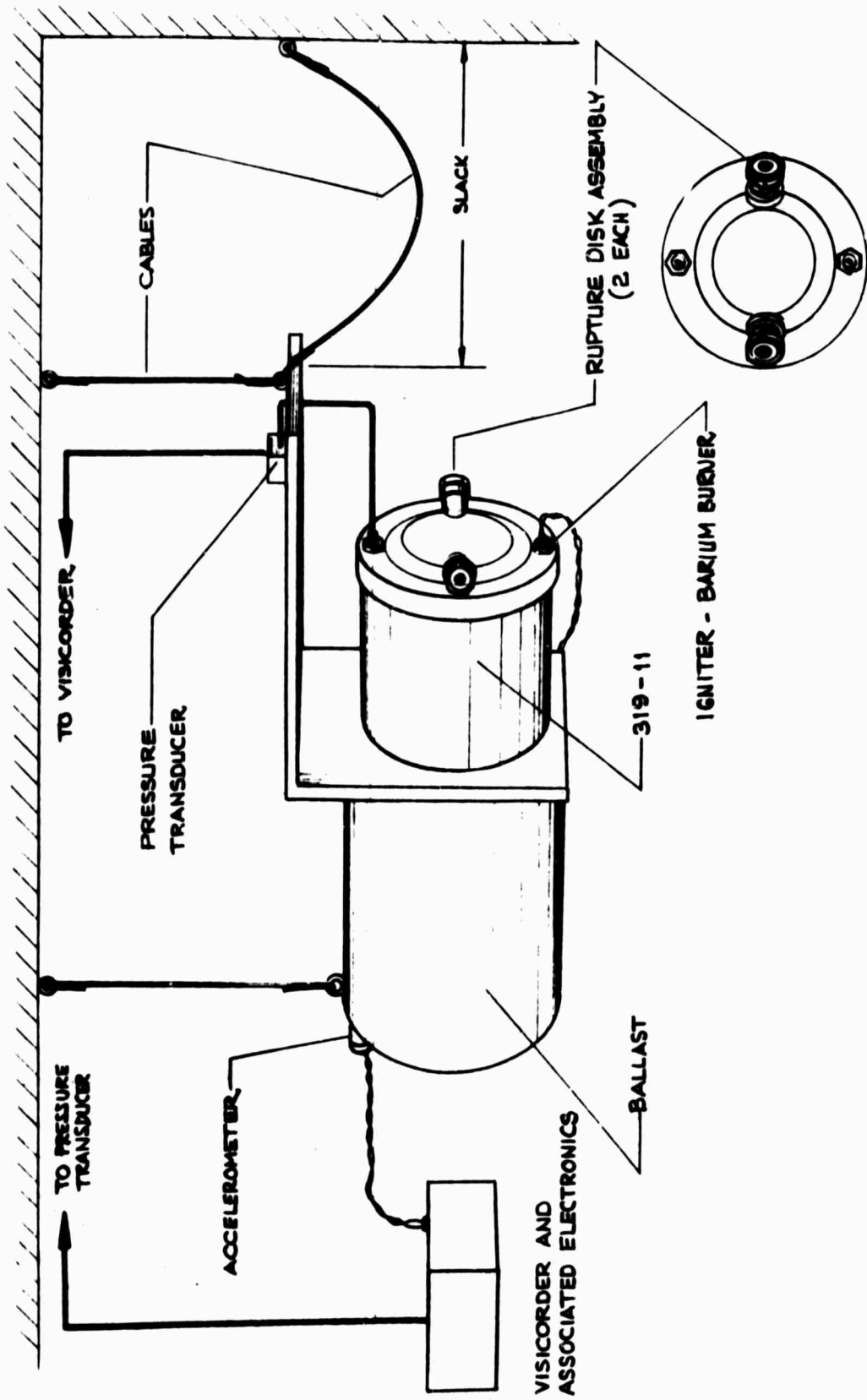

FIGURE 37 BARIUM BURNER THRUST TEST SETUP (TEST 319-3)

3.5.4.8 Lid Separation. Small scale and full scale tests were run with the 363-33 burner to verify (1) pressure switch operation, (2) ability of the delay detonator to detonate the shaped charge, (3) shaped charge cutting and (4) complete system operation. During the small scale system tests, all systems functioned satisfactorily. Full scale test indicated two problems with the system, (1) Barium clamp longitudinal support pipe bent at mid-station and punctured a hole in the side of the burner tank. The clamp consisted of a longitudinal pipe (1-inch diameter) running through the center of the burner between the lid and a circular bulkhead at the barium end of the burner. Also, silicone O-rings were used on the lid seals in lieu of the Buna N that had been used on previous tests. The silicone rings were softer than the Buna N and therefore were extruded from the groove allowing hot gas leakage that destroyed the shaped charge, precluding shape charge detonation. A new clamp was provided consisting of a thin sheet steel cylinder and bulkhead combination running the full void length of the burner with an O.D. slightly less than the I.D. of the burner. The next test was satisfactory in all respects. Additional lid separation test data are given in Appendix H.

3.6 Cesium Nitrate/Aluminum/Tungsten Burner - (Ion Generator).

3.6.1 General.

This burner was developed to react and vent approximately 5.5 pounds of a mixture of Cesium Nitrate/Aluminum/Tungsten compound for approximately 10 - 30 seconds time duration at 30,000 feet altitude.

The burner consisted of a steel canister with asbestos insulation and two graphite vent nozzles, 3.5 - 5.5 pounds of burning mix and an electro-explosive delay igniter. Figure 38 illustrates the burner. The chemical was press-loaded into the burner at 10,000 psi forming pressure. The formulations selected for the flight units were:

|     |                     |            |
|-----|---------------------|------------|
|     | 37% Cesium Nitrate  | Mix No. 3  |
|     | 19% Aluminum Powder |            |
|     | 44% Tungsten Oxide  |            |
| and | 28% Cesium Nitrate  | Mix No. 11 |
|     | 14% Aluminum        |            |
|     | 33% Tungsten Oxide  |            |
|     | 25% Tungsten        |            |

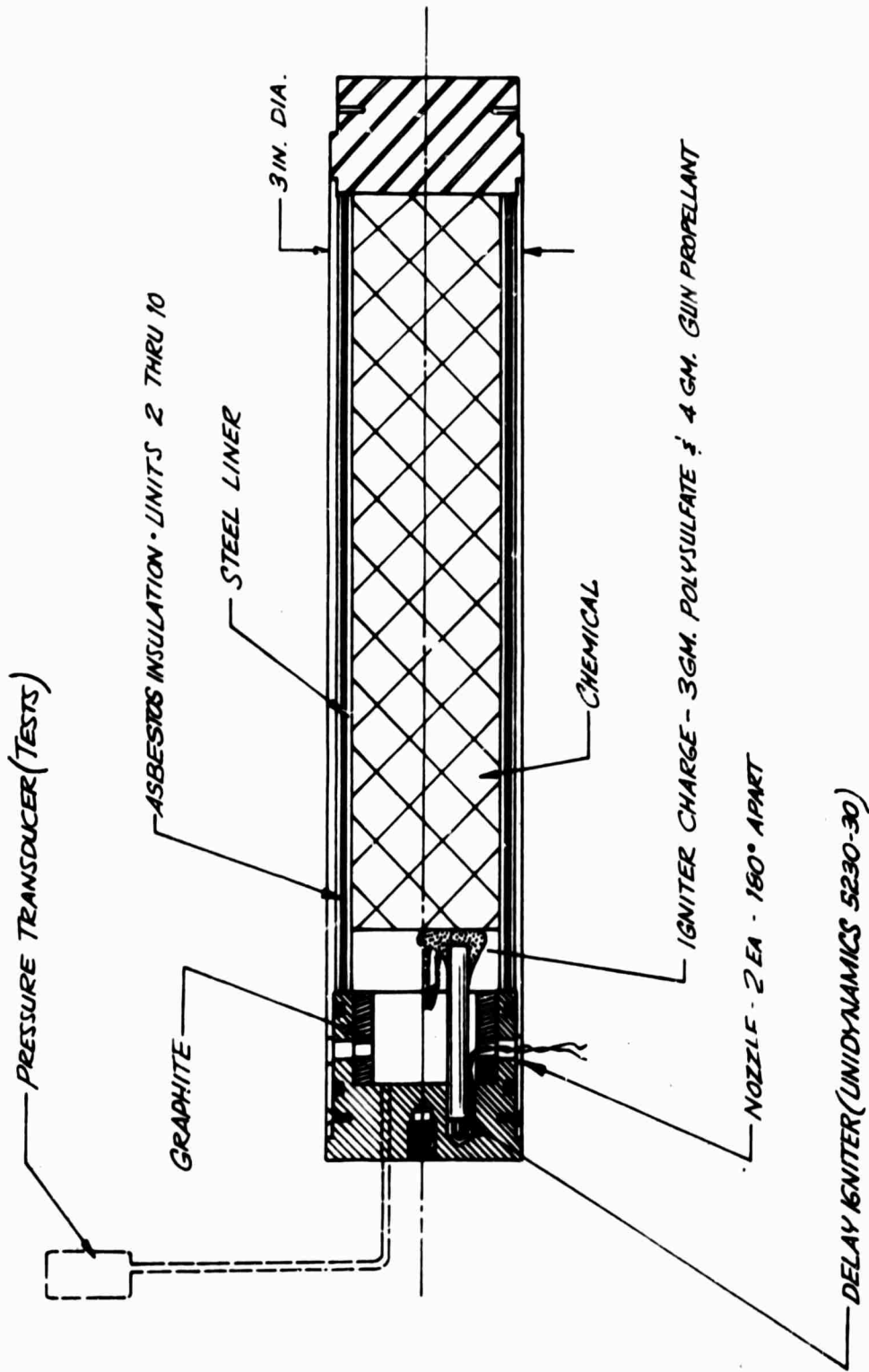

FIGURE 38 BURNER (363-10) CESIUM NITRATE/ALUMINUM/TUNGSTEN

A-1996

### 3.6.2 Tests.

An extensive series of ground tests were run on this unit. Ground tests were run to (1) optimize chemical formulation, (2) determine burn properties including burn time and burn pressure, (3) verify burner structural integrity, (4) optimize nozzle size, and (5) verify reliable ignition at flight altitude (30,000 feet). Flight tests were conducted to determine r - f characteristics of the system. Five series of tests were run.

(1) Closed bomb tests indicated that formulations selected could be ignition and would continue to burn until completely reacted.

(2) Small scale tests gave optimum (a) formulations for smooth sustained burning, (b) nozzle size, (c) igniter design and (d) void volume information.

(3) Short full diameter tests gave burn pressure and burn rates of the formulations selected.

(4) Full scale prototype tests verified the burner structural integrity including nozzle design. One test was run in a vacuum to verify ignition at flight altitudes.

(5) Flight tests indicated that the system functioned satisfactorily.

Detailed test results are given in Appendix J.

## 4. CHEMICAL HANDLING

### 4.1 General.

Chemical handling included preparation and loading of solid chemicals; and transfer of liquid and gaseous chemicals into payload tanks for ground and flight tests. These chemicals are pyrophoric, explosive or toxic; or a combination of the three. Handling techniques were developed for Nitric Oxide, Diborane, TMA, explosives, Barium burners, Cesium Nitrate/Aluminum/Tungsten burners and gas generators.

Liquids and gases were transferred through closed high pressure plumbing (1/4-inch copper tubing with 37° flare fittings) systems, liquids were transferred with dry Nitrogen pressure. The most satisfactory method found for transferring gases was to supercool the receiving tank and transfer the gas under its own vapor pressure.

Table 5 summarizes the handling, hazards and precautions to be taken for these chemicals. Where possible, chemical handling was performed in open air.

| Chemical   | Description  | Hazards   | Precautions  | First Aid   | Shpg. Class for Label | Max. Allow. Conc. per Bag | Density @ 70°F lb/cu in  | Boiling Pt. °C @ 1 Atm. | Vapor Pressure   | Compat. Materials of Construction | Transfer/Load Method | Recvr. Temp. °C | Working Atmos.               | Cleaning Solvent   |
|--|--|---|--|---|-----------------------|---------------------------|--|-------------------------|------------------|-----------------------------------|----------------------|-----------------|------------------------------|--|
| 80TMA/20TEA <sup>(4)</sup><br>80(CH <sub>3</sub> ) <sub>3</sub> Al/<br>20 (C <sub>2</sub> H <sub>5</sub> ) <sub>3</sub> Al | Colorless Liquid   | Pyrophoric<br>Toxic<br>CO                         | Firesuit <sup>(3)</sup><br>Kerosene<br>CO <sub>2</sub>                       | Remove Contaminated<br>Clothes, Shower in<br>water for 5 minutes,<br>Flush eyes gently with<br>water for 15 minutes | RED Unknown           | Unknown                   | .0278  | 139                     | 9.2 mm<br>@ 20°C | Viton A<br>Cu<br>Al               | N <sub>2</sub>       | Room            | N <sub>2</sub>               | Kerosene   |
| 80TMA/20 Normal<br>Octane  | Colorless Liquid   | Pyrophoric<br>Toxic                               | Firesuit<br>Kerosene<br>CO <sub>2</sub>                                      | Same as for TMA/TEA   | RED Unknown           | Unknown                   | .0278  |                         | 9.2 mm<br>@ 20°C | Viton A<br>Al                     | N <sub>2</sub>       | Room            | N <sub>2</sub>               | Kerosene   |
| Nitric Oxide<br>N <sub>2</sub> O   | Colorless Gas<br>Decomposes to<br>Brown NO <sub>2</sub> in Air             | Toxic   | Scrub Air Pack<br>Oxygen or Call   | Oxygen, Complete<br>Rest  | WHITE 5               | 5                         | .007 <sup>(1)</sup><br>2000 PSI<br>.001 <sup>(2)</sup><br>3000 PSI | -152                    | Ref. Fig. 40     | Teflon<br>Cu<br>Pb<br>Al          | Vapor<br>Press.      | -152            | N <sub>2</sub>               | Trichloroethane  |
| Diborane<br>B <sub>2</sub> H <sub>6</sub>  | Colorless Gas,<br>Decomposes to<br>White Vapor                             | Toxic<br>Pyrophoric <sup>(5)</sup><br>Explosive   | Scrub Air Pack<br>Oxygen or Call,<br>Firesuit, CO <sub>2</sub>               | Oxygen, Flush burn<br>with water  | WHITE<br>RED          | 0.1                       | .00375<br>500 PSI  | -92.5                   | Ref. Fig. 42     | Teflon<br>Sil<br>F e l F          | Vapor<br>Press.      | -40             | N <sub>2</sub>               | (1) Trichloroethane<br>(2) Hexane<br>(3) 50% Isopropanol<br>Alcohol, 50%<br>Hexane<br>(4) Methanol |
| Barium/Copper<br>Oxide<br>Ba / CuO   | Solid<br>Ba, 1-3 mm, Grey<br>CuO, 200 Mesh,<br>Black                       | Pyrophoric <sup>(7)</sup>                         | Firesuit<br>CO <sub>2</sub>  | Remove Contaminated<br>Clothes, Shower for 5<br>minutes in water. Flush<br>eyes for 15 minutes                      | CLASS B --            | --                        | .0185  | -                       | -                |                                   | Fresh<br>Load        |                 | Argon<br>Kerosene<br>Pentane | Pentane  |
| C <sub>5</sub> NO <sub>2</sub> /Al <sub>2</sub> WO <sub>3</sub>  | Grey, Fine Powder<br>Before Pressing<br>Solid Lump after<br>After Pressing | Flammable<br>Slightly<br>Toxic                    | CO <sub>2</sub><br>Keep Away<br>from Fire                                    | Shower for 5 minutes<br>in water  | CLASS C --            | --                        | .11<br>.12   | -                       | -                |                                   | Press<br>Load        |                 | Air                          | Pentane  |
| TNT/RDX/Ba-Mg)   | Fine Powder  | Secondary<br>Explosive<br>Toxic (Ba)<br>Flammable | CO <sub>2</sub> - Scrub Air<br>Pack on Call,<br>(Ba), Protective<br>Clothing | Flush Contaminated<br>Areas with water for 5<br>minutes, Rest and<br>Oxygen (Ba)                                    | CLASS A --            | --                        | .069 Ba<br>.08 Mg  | -                       | -                |                                   | Melt<br>Cast         |                 | Air                          | Pentane  |
| Gas Generator  | EED 209/101320   | Flammable<br>Explosive                            | Keep Away from<br>Fire, High<br>Energy RF Elec.                              |   | CLASS C               |                           |  | -                       | -                |                                   |                      |                 |                              |  |

TABLE 5 CHEMICAL PROPERTIES, HANDLING, PRECAUTIONS AND HAZARDS

- (1) In Air  
(2) Immerse burned area in water immediately in attempt to reduce burning  
(3) Complete PVC impregnated asbestos with gloves, hood, boots  
(4) Trimethylaluminum, Trichloroaluminum  
(5) Certain carboranes (i. e., hydrocarbons)  
(6) Steps 2, 3, 4 for cleaning emptied B<sub>2</sub>H<sub>6</sub> tank  
(7) Certain condition of mixture

## 4.2 Nitric Oxide.

Nitric Oxide is a colorless, highly toxic, non-flammable gas, rapidly oxidized by oxygen of the air to form nitrogen dioxide.

Exposure may cause irritation of the respiratory tract, with coughing, headache, loss of weight, loss of appetite, dyspepsia, corrosion of the teeth and loss of strength. First aid treatment includes complete rest and 100% oxygen.

Nitric Oxide is shipped in cylinders as a gas at approximately 500 psi. Figure 39 illustrates the Nitric Oxide loading system. Figure 40 gives the relation between Nitric Oxide loading density and pressure. Table 5 gives additional information.

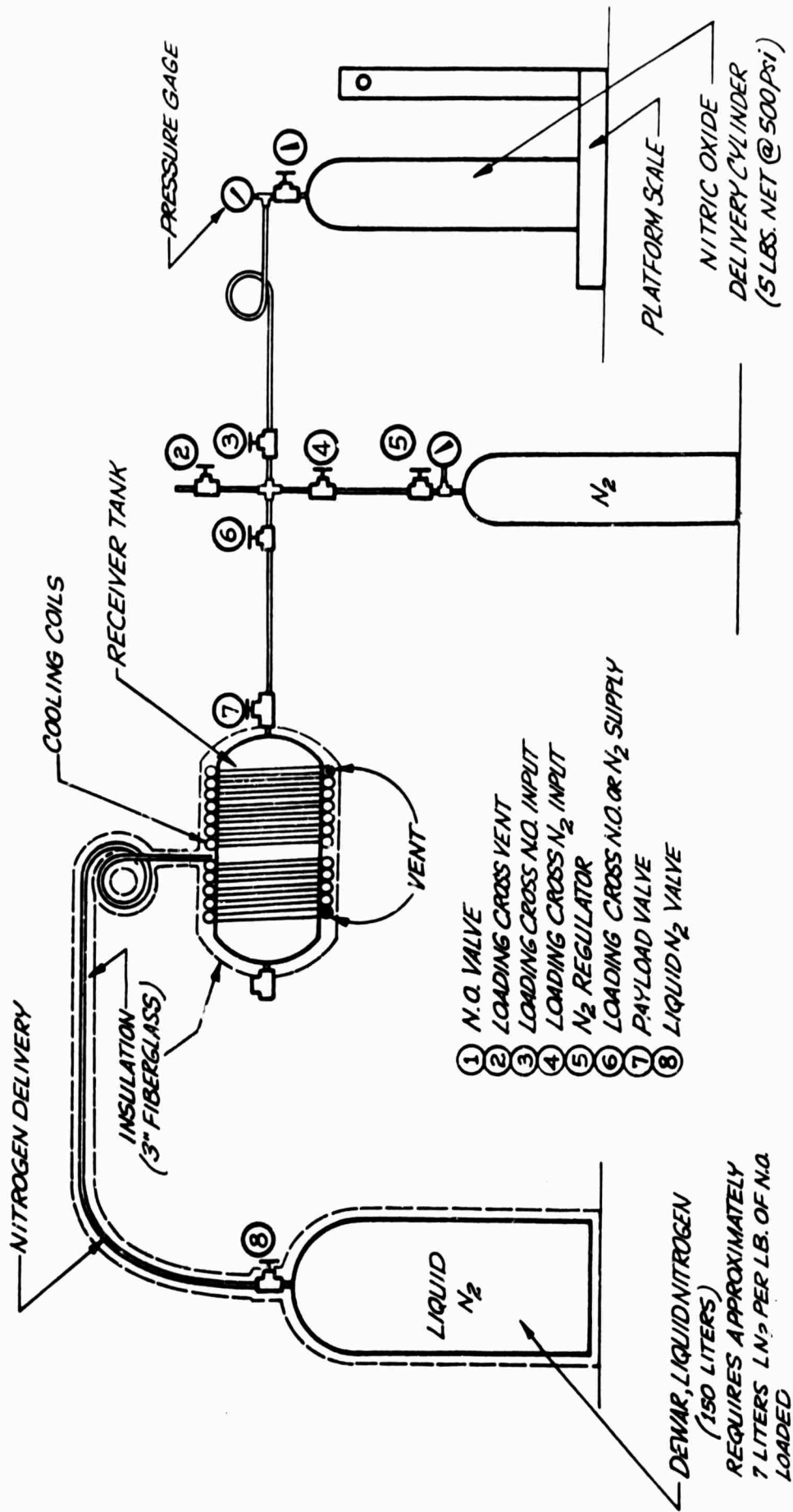

FIGURE 39 NITRIC OXIDE LOADING SYSTEM

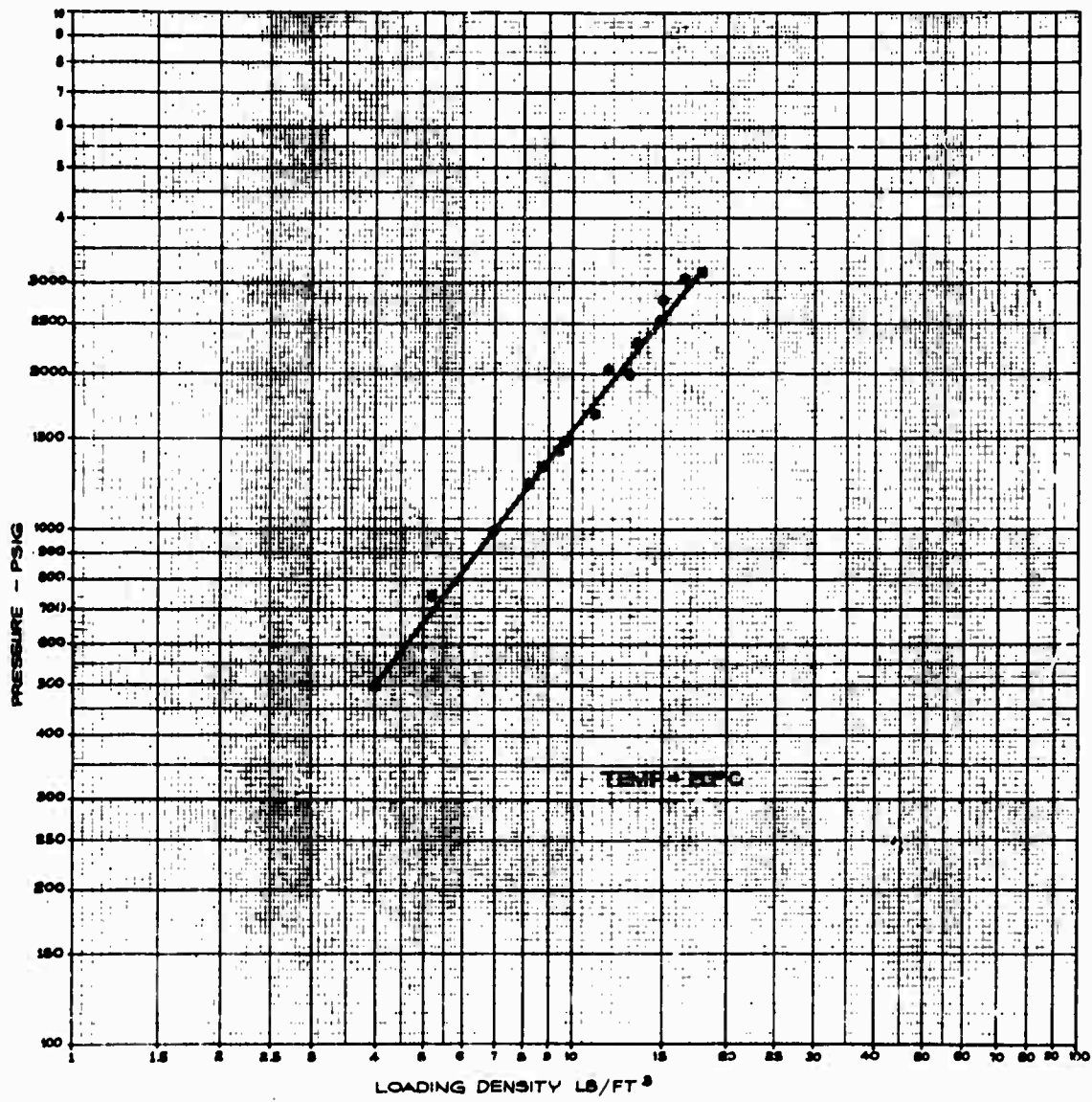

FIGURE 40 NITRIC OXIDE LOADING DENSITY vs PRESSURE

A-1998

#### 4.3 Diborane.

Diborane is a toxic gas at room temperature, and is primarily a pulmonary irritant. It hydrolyzes rapidly, and so, if not all is converted to toxic acid in the lungs, boric acid is produced and absorbed by the body and excreted in the urine. High concentrations may cause pneumonitis or affect the central nervous system.

First aid includes treatment with oxygen to help prevent pulmonary edema.

Vapor pressure versus temperature at payload loading densities are given in Figure 41.

Figure 42 illustrates the Diborane loading system. Table 5 gives additional information.

Since Diborane decomposes at temperatures above  $-20^{\circ}\text{C}$ , it is stored in dry ice ( $-78^{\circ}\text{C}$ ). Table 6 gives Diborane storage stability at various temperatures.

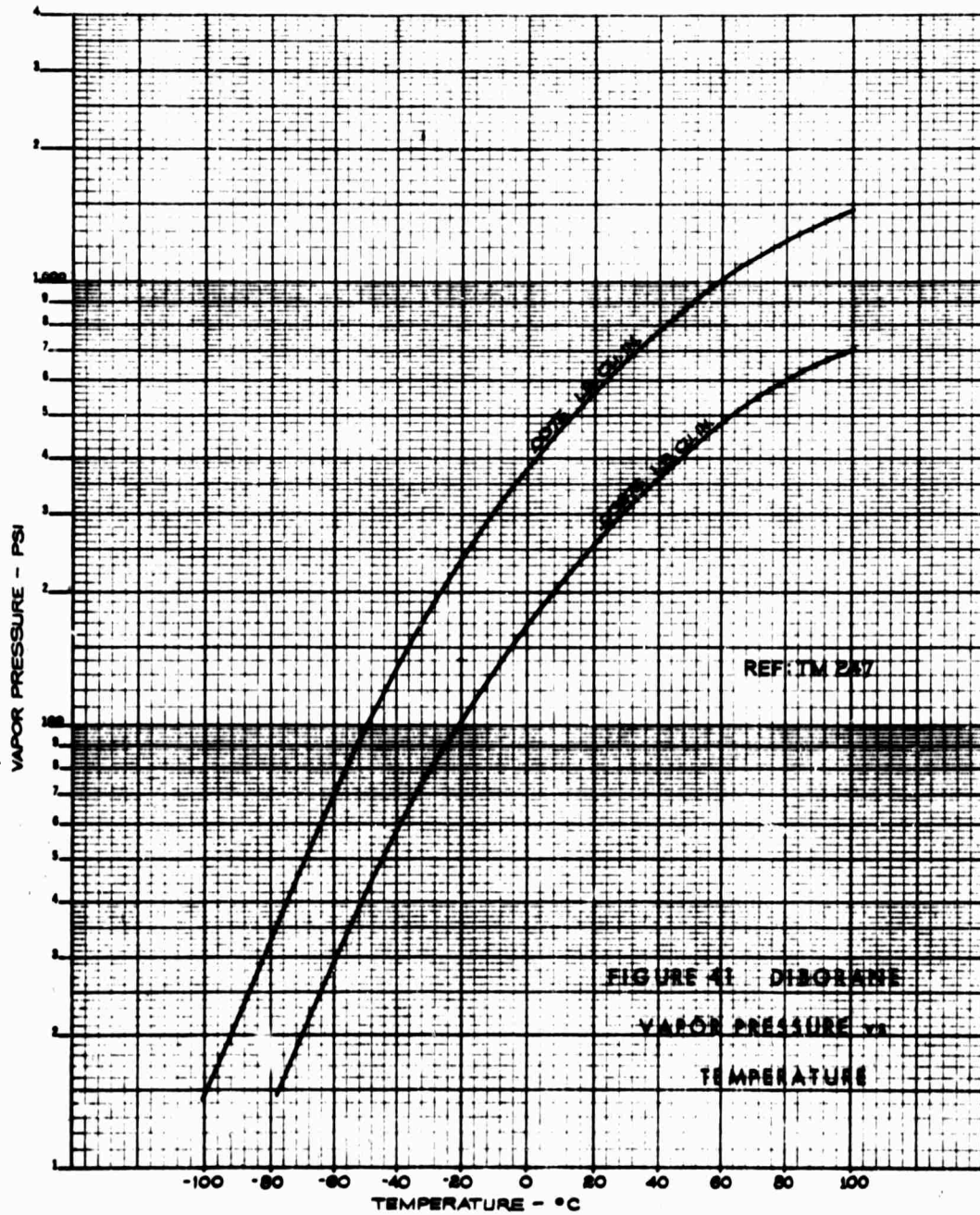

A-1999

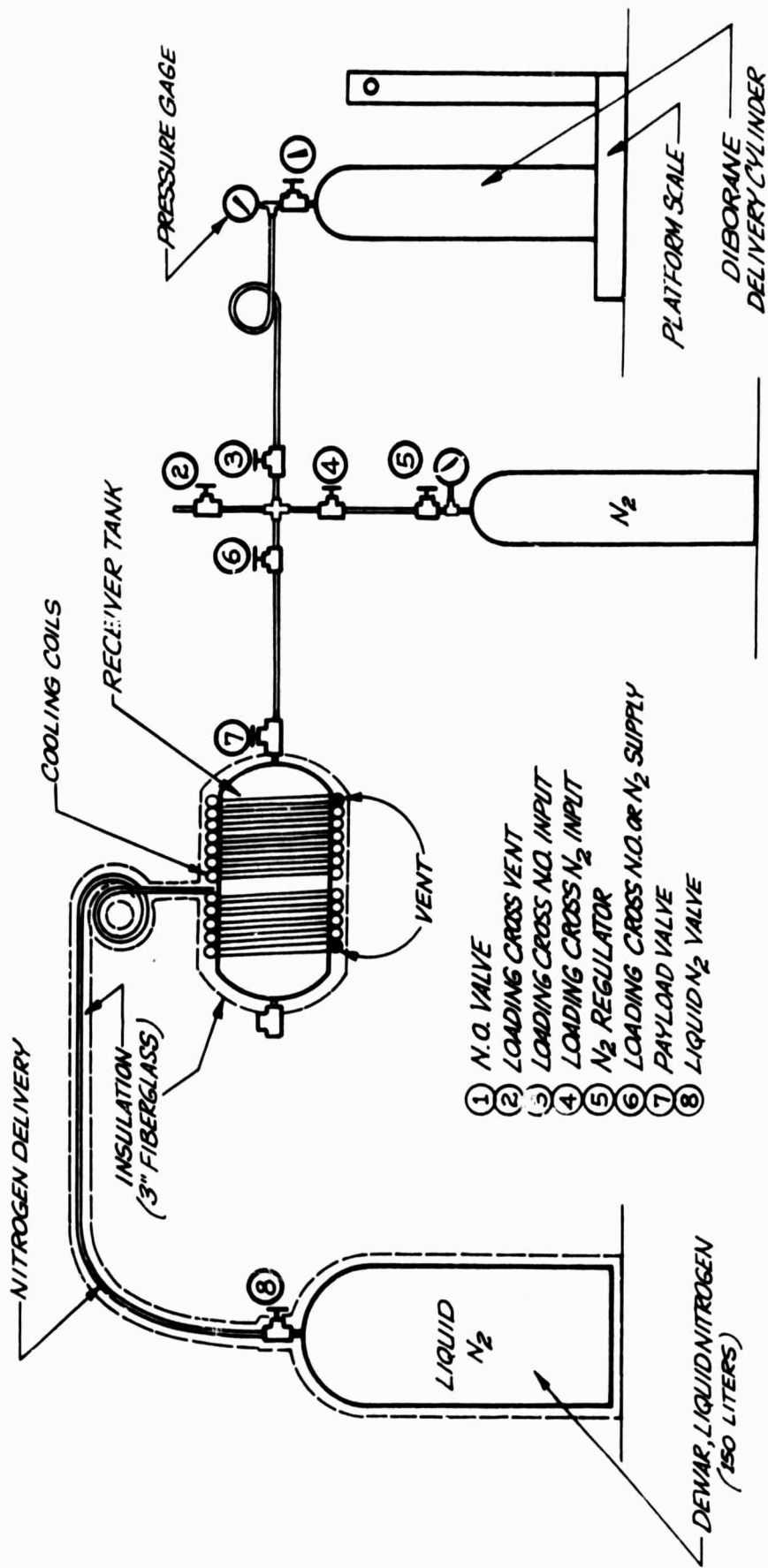
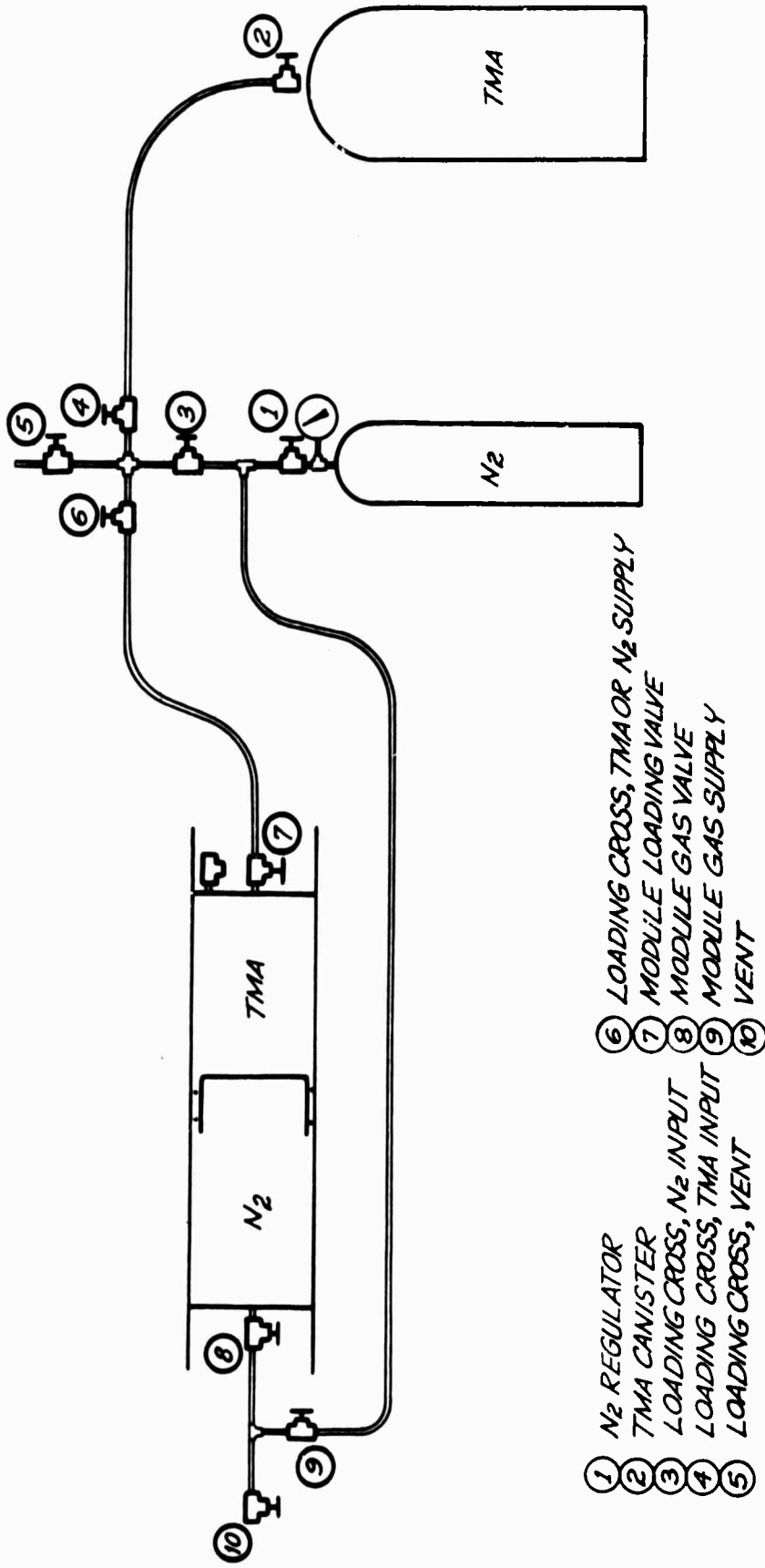

FIGURE 42 DIBORANE LOADING SYSTEM

#### 4.4 Trimethyl Aluminum.

Either TEA or Normal Octane were added (20% by weight) to the TMA to reduce the freezing point (i.e.,  $-30^{\circ}\text{C}$  for 80% TMA/20% TEA).

TMA is a colorless liquid with approximately the same density as kerosene. It is toxic, spontaneously combustible in air and reacts violently in water. Therefore, loading is performed out-of-doors, heavy fire protective clothing is worn. Burns should be immediately flushed with water to attempt to reduce burning and to cleanse the burned area. Figure 43 illustrates the TMA loading system and additional handling information is given in Table 5.



- ①  $N_2$  REGULATOR
- ② TMA CANISTER
- ③ LOADING CROSS,  $N_2$  INPUT
- ④ LOADING CROSS, TMA INPUT
- ⑤ LOADING CROSS, VENT
- ⑥ LOADING CROSS, TMA OR  $N_2$  SUPPLY
- ⑦ MODULE LOADING VALVE
- ⑧ MODULE GAS VALVE
- ⑨ MODULE GAS SUPPLY
- ⑩ VENT

FIGURE 43 TMA LOADING SYSTEM

#### 4.5 High Explosives - (Mg or Be).

TNT and composition B secondary high explosives were melted at approximately 90° C and either Magnesium or Beryllium were added and mixed. Compositions containing 60% RDX and 40% TNT were added to the TNT to give the desired proportions of RDX/TNT. This precluded handling RDX alone. RDX is more shock sensitive than TNT and composition B.

The beryllium ingredient is highly toxic. Maximum allowable concentrations are not known, although extreme care should be taken to avoid ingestion or contact with the skin. Respirators and protective clothing should be worn during all beryllium handling. Table 5 give additional handling information.

#### 4.6 Barium/Copper Oxide.

Barium/copper oxide mixture preparation is outlined in Figure 44. Barium was received in 0.75-inch diameter x 4-inch long sticks, packed in oil and was handled in three atmospheres; grinding in kerosene, washing in pentane and drying, transfer, mixing and loading in argon. Glove bags were used for operations involving argon.

Purity checks were run on kerosene, pentane and argon by placing small quantities of ground barium in a jar, filling the jar with the material being tested and checking for reaction. Also, glove bags were checked for humidity and oxygen.

A major consideration during handling was safety. Extreme care was taken to insure that moisture or contaminants were not present. The following handling precautions have been adopted as a result of this program.

- (1) Handling was performed on days of relative humidity of 40% or less;
- (2) Handling was performed with two pairs of rubber gloves that were leak checked frequently;
- (3) Handling was performed out-of-doors;
- (4) Direct handling was limited to one operator ;
- (5) Press-loading was performed remotely;
- (6) Equipment and gloves were washed in pentane and dried thoroughly prior to using;
- (7) A minimum quantity of chemicals were handled at one time;
- (8) Each operation was separated a safe distance from the other;
- (9) Kerosene, pentane, argon and lubricants were purity checked prior to use;
- (10) Humidity (10% maximum) and oxygen content (1% maximum) were determined in argon filled glove bags prior to use;
- (11) Water deluge shower and CO<sub>2</sub> fire extinguishers were always available in the immediate vicinity;
- (12) Medical help was accessible who were familiar with the required treatment.

BARIUM MIX PREPARATION

4-26-68 EFA

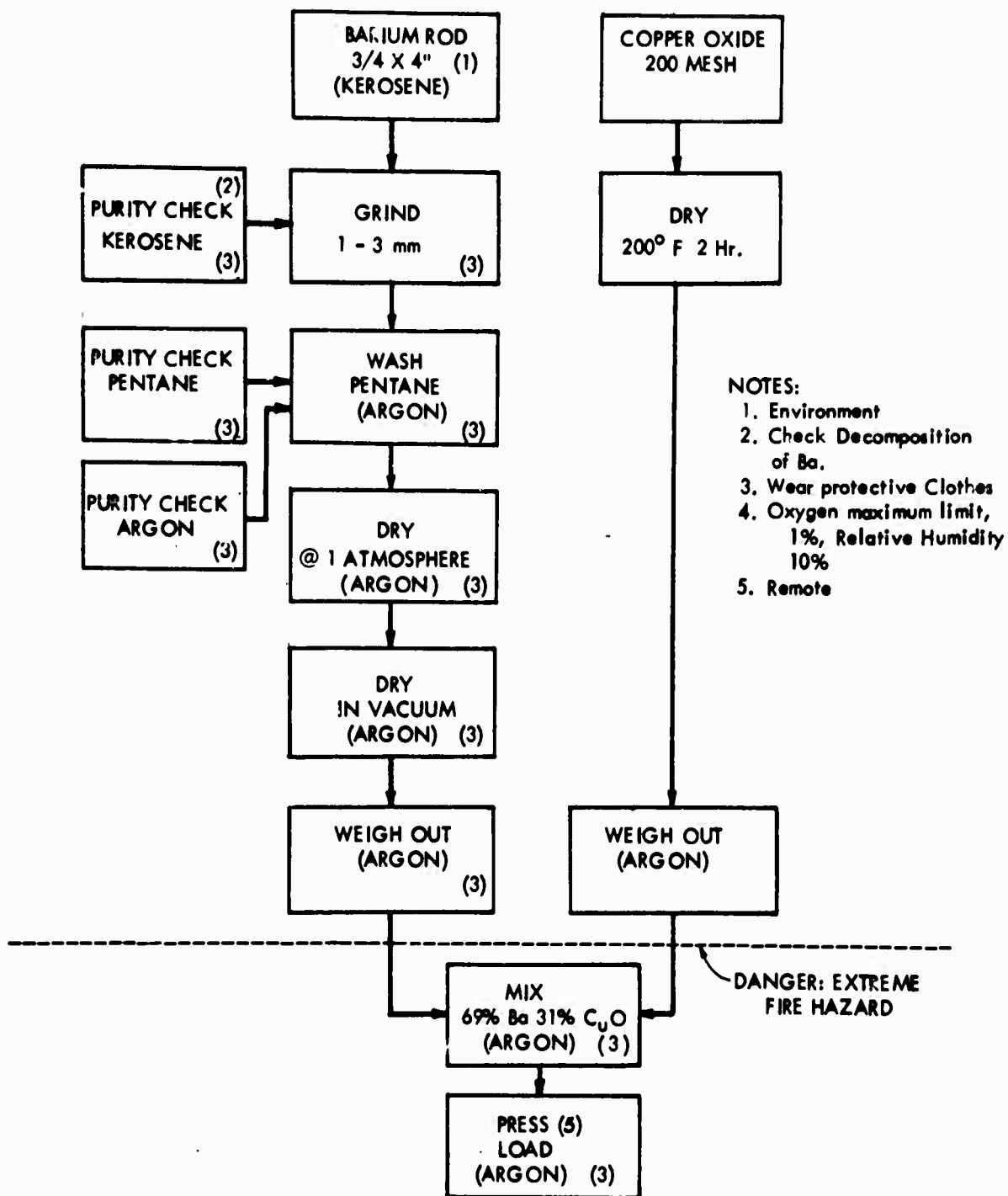

- NOTES:
1. Environment
  2. Check Decomposition of Ba.
  3. Wear protective Clothes
  4. Oxygen maximum limit, 1%, Relative Humidity 10%
  5. Remote

A-2000

FIGURE 44 BARIUM/COPPER OXIDE PREPARATION

Continual inhalation into the respiratory system or absorption into cuts or through the pores may cause a problem. Large concentrations in the system may affect the central nervous system. Table 5 gives additional handling information.

4.7 Cesium Nitrate/Aluminum/Tungsten Compounds.

These materials are slightly toxic, mainly if the dusts are ingested. Chemicals, except Cesium Nitrate, were received in the proper particle size. Cesium Nitrate was ground in a ball mill. The chemicals were mixed and press-loaded into the burner at 10,000 psi loading pressure.

#### 4.8 Gas Generators.

The gas generator in the hot gas accumulator and squib valve (272-10) consisted of an EED and boron potassium nitrate propellant.\* The EED's (ARC 209 or SD1 101350) were 1 amp, 1 watt maximum no-fire 5 minute devices. The boron potassium nitrate is a Class C propellant, easily ignited by simple flame, producing approximately  $1.3 \times 10^6$  ft-lb/lb, of energy. Table 5 gives additional handling information for gas generators.

\* Boron 24%  
Potassium Nitrate 70%

Luminac = 98% }  
Lupersol = 2% } 6%

A number of storage test programs were undertaken to determine the extent of decomposition of Diborane at various temperatures as a function of time. The following is a tabulation of the reported data based on pressure build-up in the cylinder.

- (a) Approximately 0.15 mm Hg pressure rise after 100 days at  $-33^{\circ}$  C.
- (b) After one (1) year at  $-20^{\circ}$  C, there was an overall pressure rise of 10 psig. This was calculated to be equivalent to about 0.2% decomposition of the Diborane.
- (c) At  $-17.8^{\circ}$  C, after 100 days, a pressure rise of 0.14 atmospheres was recorded.
- (d) At  $0^{\circ}$  C, after three (3) months, less than an atmosphere of pressure increase was recorded.
- (e) At  $+7^{\circ}$  C, after 100 days, the recorded pressure rise was about 1 atmosphere.
- (f) At  $+16^{\circ}$  C, after 100 days, the pressure rise was about 6 atmospheres, which is still less than 10% decomposition of the Diborane.
- (g) Diborane stored at  $25^{\circ}$  C for four (4) months showed a pressure rise of 52 atmospheres and analysis showed that 40-60 per cent of the Diborane was left after the test period.

NOTE: Items (a), (c), (e) and (f) are calculated data.

TABLE 6  
DIBORANE STORAGE STABILITY

5.  
REFERENCES

- SDC Bid 47  
21Jan65      Technical Proposal submitted to AFCRL in response to Purchase request no. 55859, Engineering Services for Designing, Developing and Testing Upper Atmosphere Chemical Release Payloads.
- SDC TM 105  
Revision A  
18 Apr66      Parameters, Test Data & Design Criteria for Toggle & Geneva Intermittent Valve System - Contract AF 19(628)5125.
- SDC TM 132  
Revision A  
15Aug66      Nitric Oxide Payload Development & Flight Test Report
- SDC TM 193  
Revision A  
24Mar67      Progress Report - Barium Burner Tests
- SDC TM 225  
21Jul67      Nitric Oxide Payload Tests
- SDC TM 226  
21Jul67      Analysis Report of Barium Burner Tests through July 1967 - Internal Report.
- SDC TM 247  
5Sept67      Diborane Payload Ground Safety Procedure
- SDC TM 225  
19Sep67      Barium Calorimeter Test Report
- SDC TM 266  
16Oct67      Diborane Preliminary Test Report

6.  
PARTS LIST

| PART NUMBER | NAME   |
|-------------|--|
| 277-10      | Nitric Oxide Trail Payload (25 pounds Net)                                   |
| 349-10      | Diborane Trail Payload (4 pounds net)  |
| 299-11      | TMA Trail Payload (Baffled Tank)   |
| 308-11      | TMA Trail Payload (Accumulator Tank)   |
| 213-11      | TMA Four "Point" Payload   |
| 278-11      | High Explosive Payload   |
| 309-12      | Barium Three Burner Payload (2.4 Kg - 5.3 pounds each)                       |
| 319-12      | Barium Three Module Payload (6 Kg - 13.2 pounds each)                        |
| 319-11      | Barium Module ( 6 Kg) (13.2 pounds)  |
| 333-11      | Barium Module (13.6 Kg)(39 pounds)   |
| 333-12      | Barium Module ( 6 Kg)( 12.3 pounds)  |
| 351-10      | Barium - Delayed Release Payload (Large Void - 48 pounds net)                |
| 363-10      | Barium - Delayed Release Payload (Large Void - 12 pounds net)                |
| 362-10      | Cesium Nitrate/Aluminum/Tungsten Payload                                     |
| 273-10      | Squib Valve  |
| 284-11      | Intermittent Release System: Cam Operated Toggle Valve<br>(Cam Follower)     |
| 284-12      | Intermittent Release System: Cam Operated Toggle Valve<br>(Ball Follower)    |
| 322-11      | Intermittent Release System: Solenoid Actuated Valves<br>(Schematic 284-214) |

371-10 Intermittent Release System: Solenoid Actuated Valve  
(Schematic 371-28)

308-36 Tank - Low Pressure Liquid ( 9" O.D., 1400 Cu In.)  
(Reference Drawing No. 308-11).

299-34 Tank - Low Pressure Liquid (4.5" O.D., 97 Cu In.)  
(Reference Dwg No. 299-11).

312-32 Tank - Low Pressure Liquid (3 " O.D., 105 Cu In)  
Hot Gas Accumulator

277-43 Tank - High Pressure Gas (9" O.D., 2185 Cu In.)  
(Reference Drawing No. 277-10)

349-22 Tank - High Pressure Gas (9" O.D., 1050 Cu In.)

355-60 Tank - High Pressure Gas (7.75 " O.D., 1050 Cu In.)

262-57-1 Programmer - Single Event, Dual EED ( 6.250 I.D. Payload)  
(Reference Schematic 278-35).

262-57-2 Programmer - Single Event, Dual EED (6.375 I.D. Payload)  
(Reference Schematic 278-35)

319-40 Programmer - Single Event (3.5 I.D. Payload) (Reference  
319-11) (Schematic 278-35).

277-39 Programmer - Single Event, Single EED (Reference 277-10)  
(Schematic 277-44).

363-34 Programmer - Lid Separation (Reference Drawing 363-11)  
(Schematic 363-28).

309-43 Programmer - Triple Event, (Reference Drawing 309-12)  
(Schematic 278-35.)

372-10 Electronic Sequencer (Schematic 372-21).

309-24 Barium Burner (2.4 Kg - 5.3 pounds)

309-41 Barium Burner - T Nozzle (2.4 Kg - 5.3 pounds)  
319-39 Barium Burner (6 Kg - 13.2 pounds) (Reference Dwg. 319-11).  
333-34 Barium Burner (6 Kg - 13.2 pounds) (Reference Dwg. 333-12).  
333-35 Barium Burner (13.6 Kg - 30 pounds) (Reference Dwg. 333-11).  
363-33 Barium Burner - Delayed Release (5.45 Kg - 12 pounds)  
(Reference Drawing 363-33).  
351-10 Barium Burner (21.7 Kg - 48 pounds) (Reference Dwg 351-10).

NOTE: Where next assembly referenced - parts are called out on that assembly.

**APPENDIX A**

**PAYLOAD DESIGN AND TEST CRITERIA**

## PAYLOAD DESIGN AND TEST CRITERIA

1. Bending: Nose cone to cylinder = 57,000 in/lb  
Cylinder = 100,000 in/lb
2. Stiffness (E) times (I) =  $1.5 \times 10^8$  lb-in<sup>2</sup>
3. Shock (Rocket Powered Flight) Long Axis: Sawtooth 5 ms Onset,  
1 ms Decay 90 g's  
Long Axis: Half Sine 5 ms 40 g's
4. Acceleration (Rocket): Steady State, Long Axis
  - a. Rocket Powered Flight: 20 sec, 70 g's
  - b. Drag After Burnout: 20 sec, 10 g's
5. Vibration (Rocket Powered Flight) Three mutually perpendicular axes:  
Frequency Range 10-2000 cps at 0.25 in double amplitude or  $\pm 20$  g's  
at 30 seconds per octave
6. Skin Heating: Payload skin housing the pyrotechnics: less than 150° C  
during rocket flight

APPENDIX B

NITRIC OXIDE PAYLOAD TESTS  
(REFERENCE TM 225)

**BLANK PAGE**

## TABLE OF CONTENTS

1. INTRODUCTION
2. PAYLOAD SYSTEM
3. INSTRUMENTATION
4. NITRIC OXIDE LOADING
5. DATA RECORDING
6. RESULTS

- |            |                               |
|------------|-------------------------------|
| APPENDIX 1 | THRUST VS PRESSURE COMPARISON |
| APPENDIX 2 | THRUST VS TIME COMPARISON     |
| APPENDIX 3 | REGULATOR FLOW TESTS          |

## LIST OF FIGURES

### FIGURE

1. TEST SET UP
2. NITRIC OXIDE LOADING SYSTEM
3. PRESSURE vs TIME COMPARISON - SYSTEM NO. 1
4. PRESSURE vs TIME COMPARISON - SYSTEM NO. 2
5. NITROGEN THRUST vs PRESSURE - SYSTEM NO. 1
6. NITROGEN THRUST vs PRESSURE - SYSTEM NO. 2
7. NITRIC OXIDE AND NITROGEN THRUST COMPARISON
8. PRESSURE & THRUST vs TIME - FLIGHT NO. 1
9. PRESSURE & THRUST vs TIME - FLIGHT NO. 2

## 1. INTRODUCTION AND SUMMARY.

In June 1966 two (2) nitric oxide payloads, code names Baby and Cora, were launched from Eglin Air Force Base, Florida, aboard Nike-Iroquois carrier vehicles. Approximately twenty-two (22) pounds of nitric oxide was carried in each payload. Due to the problems associated with data interpretation, and hazards associated with handling the nitric oxide for these flights, a test program was conducted by Space Data Corporation to:

1. Compare thrust values of nitric oxide and nitrogen under the same release conditions.
2. Develop safe nitric oxide handling techniques.
3. Reconstruct the flight systems and determine nitric oxide thrust as a function of time for the two flights.

This report describes the procedures used and the results of this program.

As a result of this program, an efficient and safe method of loading nitric oxide was developed; also, thrust values for nitric oxide were found to be approximately five percent greater than nitrogen, and nitric oxide thrust versus time values were determined for both flight systems.

## 2. PAYLOAD SYSTEMS.

Release tests were run with two systems; (1) a flight payload (277-11) identical to those flown, and (2) a small scale tank (336-21) using the same fluid control devices as the flight systems and having approximately one-third ( $V_f = 3.22 V_p$ ) the volume of the flight tank. These systems are illustrated in Figure 1.

The flight payload was used to (1) determine regulator settings to match the flight systems, and (2) determine thrust versus pressure values at the flight regulator settings.

The smaller tank was used to compare nitric oxide and nitrogen thrust levels and to qualify a prototype nitric oxide tank in the expected cryogenic and pressure environments. A hand valve (90° bail) was added to the system to enable manual turn-on and turn-off of the flow. Tests were run to verify that the addition of this hand valve did not affect flow. Releases were run with an opened explosive valve. During tests the complete system was suspended from a double pendulum as shown in Figure 1.

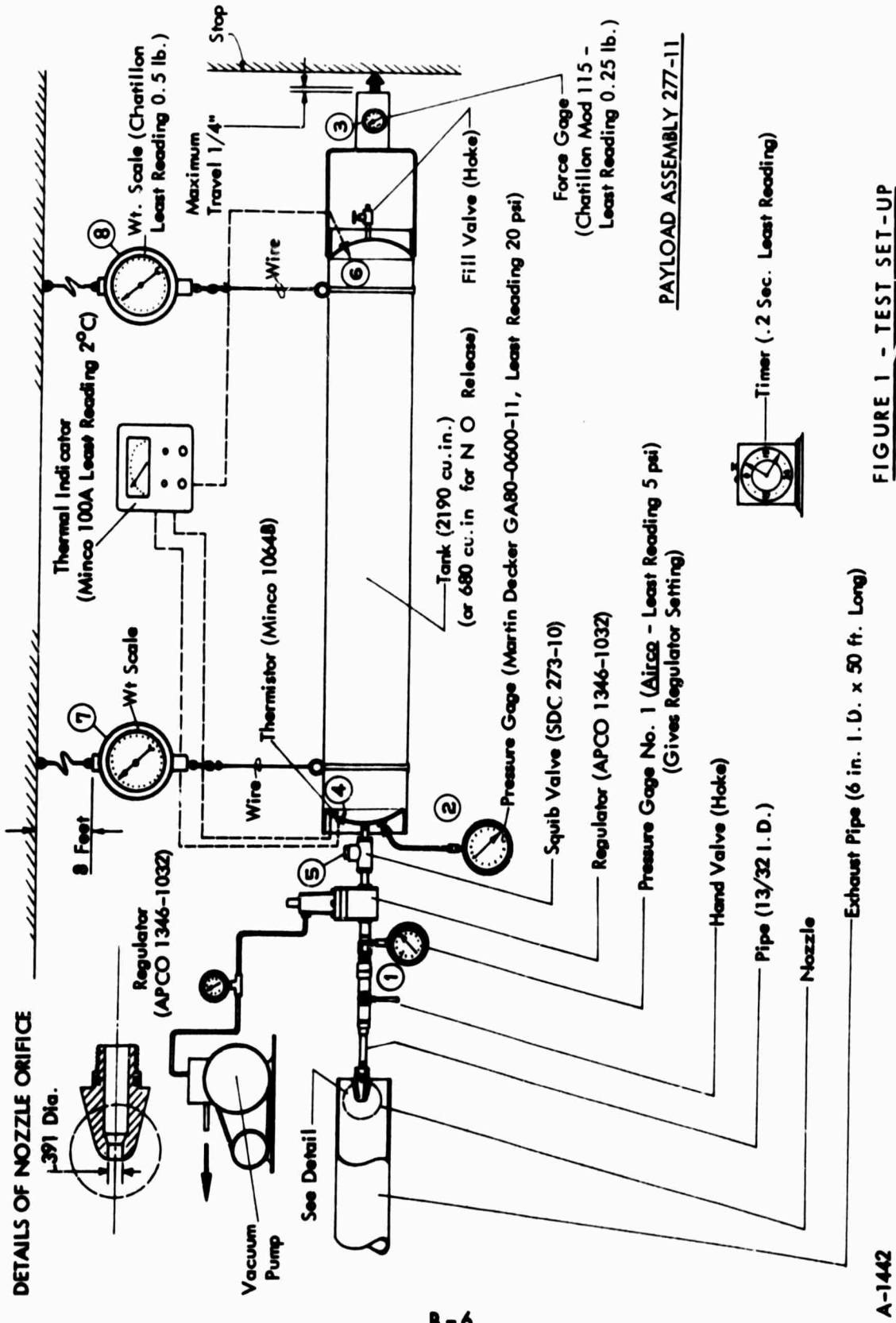

B - 6

A-1442

**FIGURE 1 - TEST SET-UP**

### 3. INSTRUMENTATION.

A Bourdon pressure gauge was used to measure tank pressure. Tank temperature was measured with resistance thermister with a readout temperature gauge. Thermistors were mounted on the inside of each end of the tank to measure gas temperature and on the outside of the forward tank end to measure tank temperature.

Weight was measured with a spring weight balance.

Thrust was measured with a direct reading thrust gauge. Errors due to motion of the system were considered negligible since swing of the pendulum was limited to less than 0.25 inches during measurements.

The locations and further descriptions of the various instrumentation are given in Figure 1.

#### 4. NITRIC OXIDE LOADING.

Since nitric oxide is supplied by Matheson at 500 psi maximum pressure, loading was accomplished by feeding the nitric oxide into the receiver tank under its own vapor pressure with the receiver tank super-cooled to obtain the 17.5 pounds per cubic foot flight loading density at 100 psi vapor pressure.

Figure 2 illustrates the nitric oxide loading system. Cooling was accomplished with liquid nitrogen which was boiled through 100 feet of 1/4" O.D. copper tubing wrapped around the receiver tank. The receiver tank was insulated in approximately 2 inches of vermiculite. The nitrogen was supplied from a 150 pound high pressure delivery dewar. Cooling rate was approximately 2° C/minute. The receiver tank was cooled to approximately -140° C prior to nitric oxide loading. Thus, approximately four pounds of nitric oxide was obtained from each delivery cylinder that initially contained five pounds of nitric oxide net at 500 psi. Net weight of nitric oxide loaded was determined by weighing the delivery cylinder during loading. After loading, the tank was heated to the desired temperature for the ground release test with a 1300 watt electric heater.

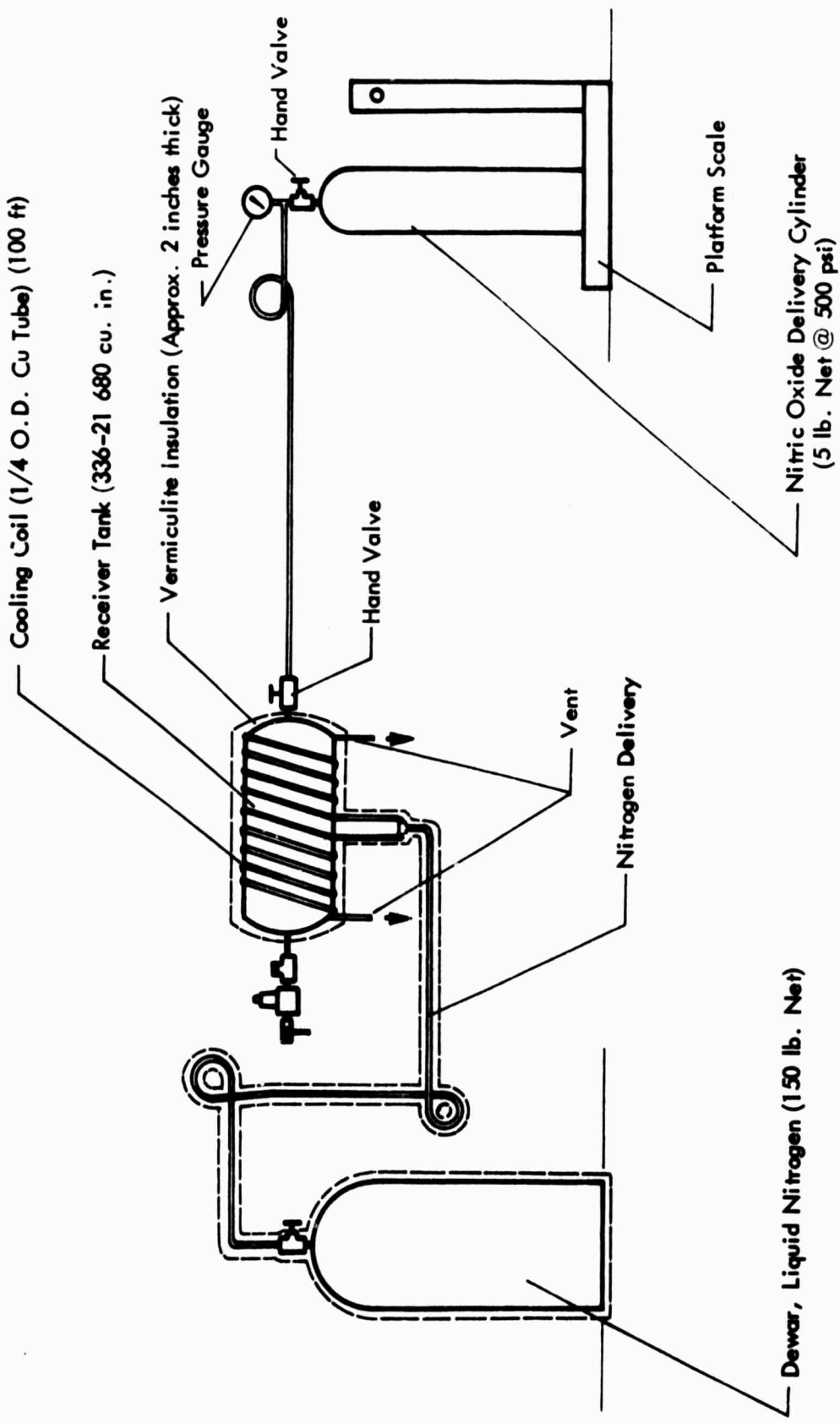

FIGURE 2 - NITRIC OXIDE LOADING SYSTEM

5. DATA RECORDING.

Pressure, temperature and thrust data were recorded by manually marking the indicator positions on the respective gauges at five second intervals during the release. Then, after the release, the corresponding gauge readings were tabulated.

## 6. RESULTS.

First, the regulator settings for the flight systems were determined by running a series of nitrogen ground release tests at various regulator settings to match pressure versus time histories of the flight system nitrogen releases (SDC TM-132, Runs 19 and 21). Figures 3 and 4 are comparisons of pressure versus time plots for releases most closely matching the flight system.

Then, tests were run to determine the operating characteristics of the regulator and it was found that thrust values for a given regulator setting are defined by tank pressure. This was verified by running tests with the same fluid control settings but with the two different sized tanks (2190 and 680 cubic inches). Results of these tests are presented in Appendix A. (Mass Flow vs Regulator Setting is given in Appendix B.)

Then, nozzle thrust versus pressure values for nitrogen at flight regulator settings (210 and 287 psi) were determined from nitrogen releases using the system illustrated in Figure 1. The regulator was evacuated (29 inches Hg Vacuum) to simulate the effect of release altitude on the regulator setting. Figures 5 and 6 are thrust versus tank pressure plots for these flight regulator settings. Comparisons of thrust versus time with the regulator evacuated and at sea level are given in Appendix E.

Then, tests were conducted using the prototype (236-21; 680 cubic inch) tank to compare the thrusts of nitric oxide and nitrogen under the same release conditions (initial pressure, initial temperature, regulator setting). These tests showed nitric oxide thrust levels to be approximately 5% greater than nitrogen. These results are plotted in Figure 7. Due to the compressibility of nitric oxide, approximately 30% more nitric oxide than nitrogen was released during these tests. Therefore, the time of release for nitric oxide was longer.

Since thrust was defined by tank pressure for the flight systems, (Figure 5 and 6), it was possible to assign nitrogen thrust values to the flight payloads by correlating these thrust values with the pressure versus time histories obtained from flight telemetry records as shown in Figure 8 and 9.

Then, these nitrogen thrust values were increased by 5% (from Figure 7) to give equivalent nitric oxide thrust values. Nitric oxide thrust values are also plotted in Figures 8 and 9.

Two major limitations of the above approach are: (1) Thrust measurements were made at sea level rather than in a vacuum, and (2) it was impossible to exactly match the tests regulator flow characteristics with the flight systems. Neither of these limitations contribute significant errors to the thrust values.

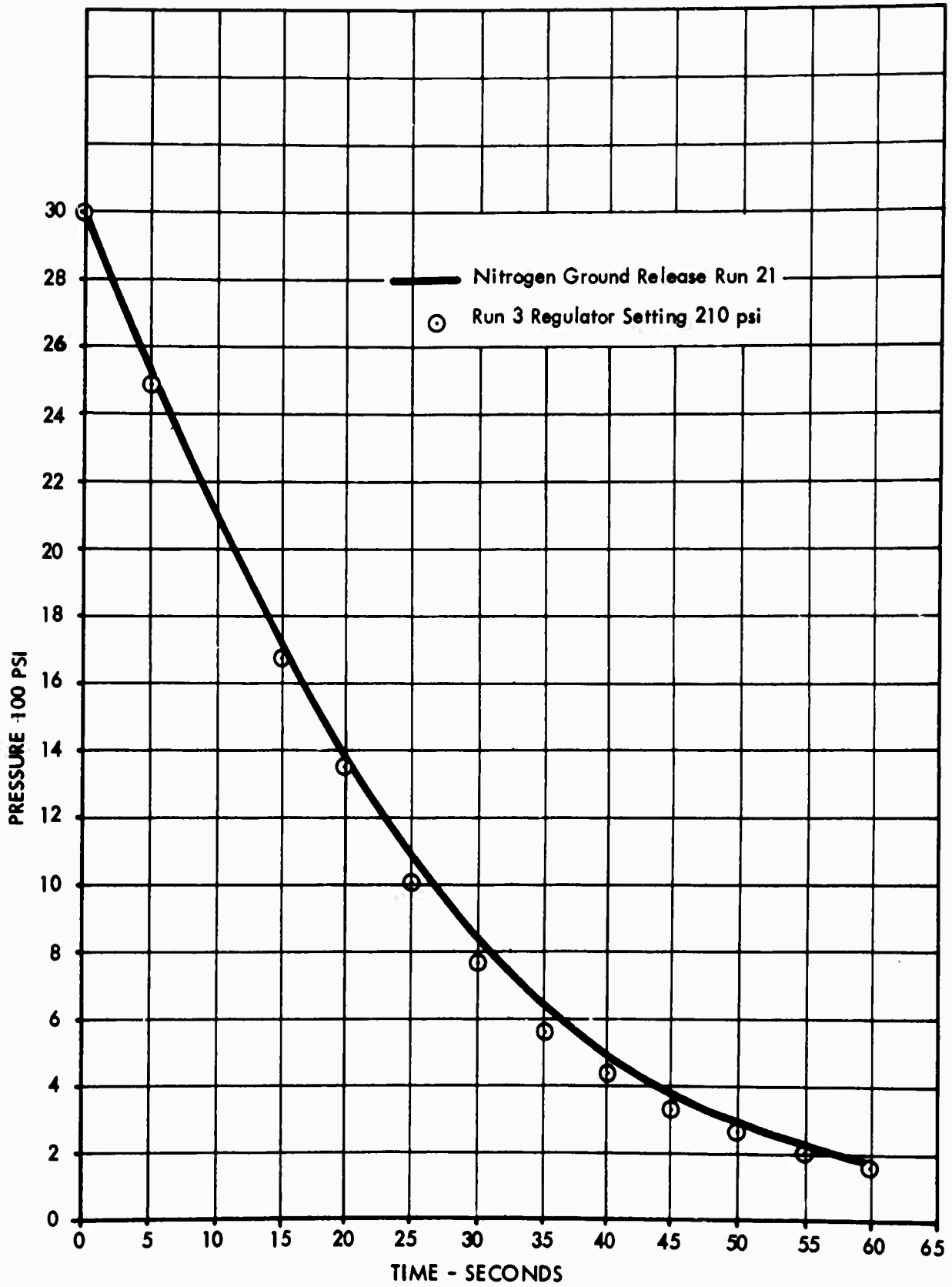

FIGURE 3 - PRESSURE VS. TIME COMPARISON - SYSTEM NO. 1

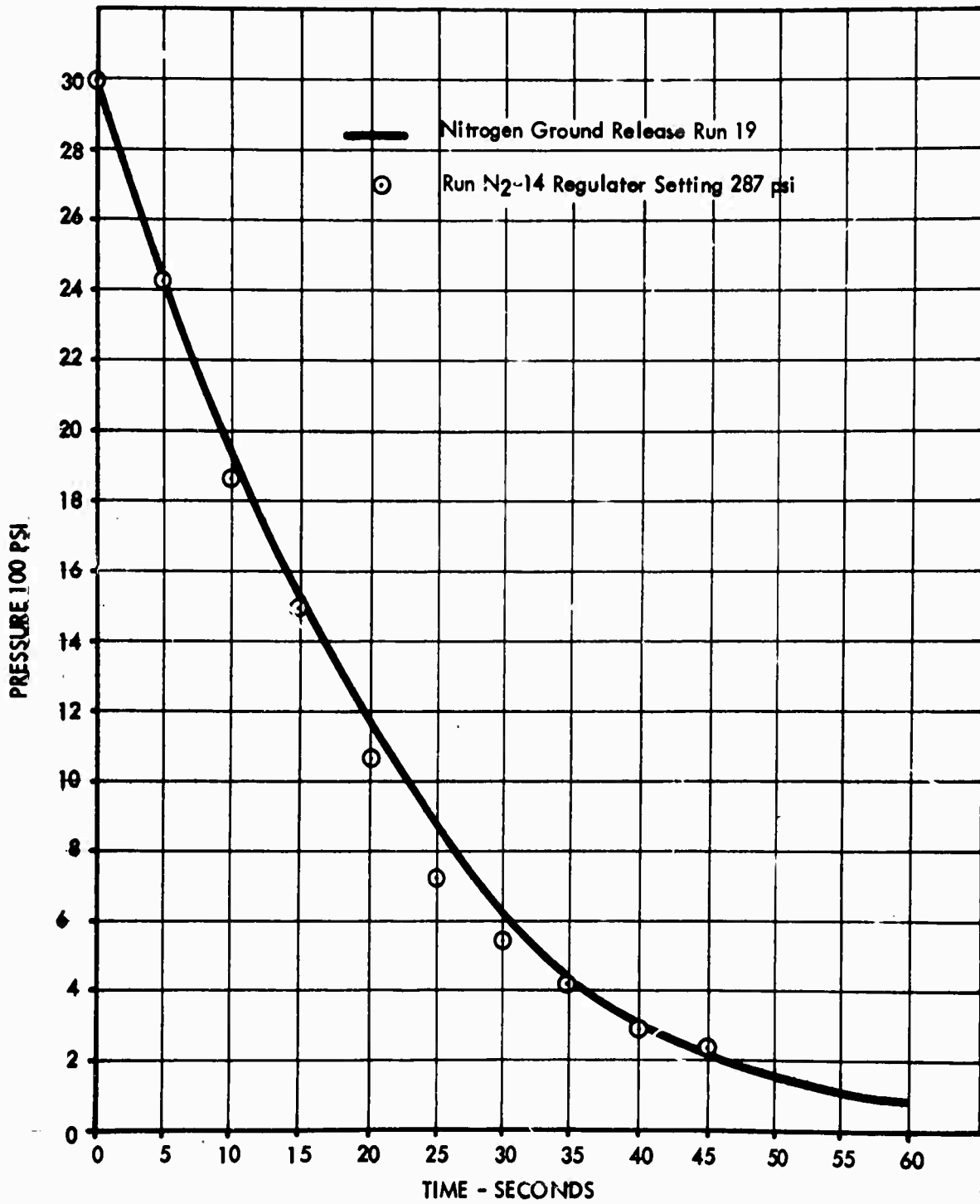

FIGURE 4 - PRESSURE VS. TIME COMPARISON - SYSTEM NO. 2

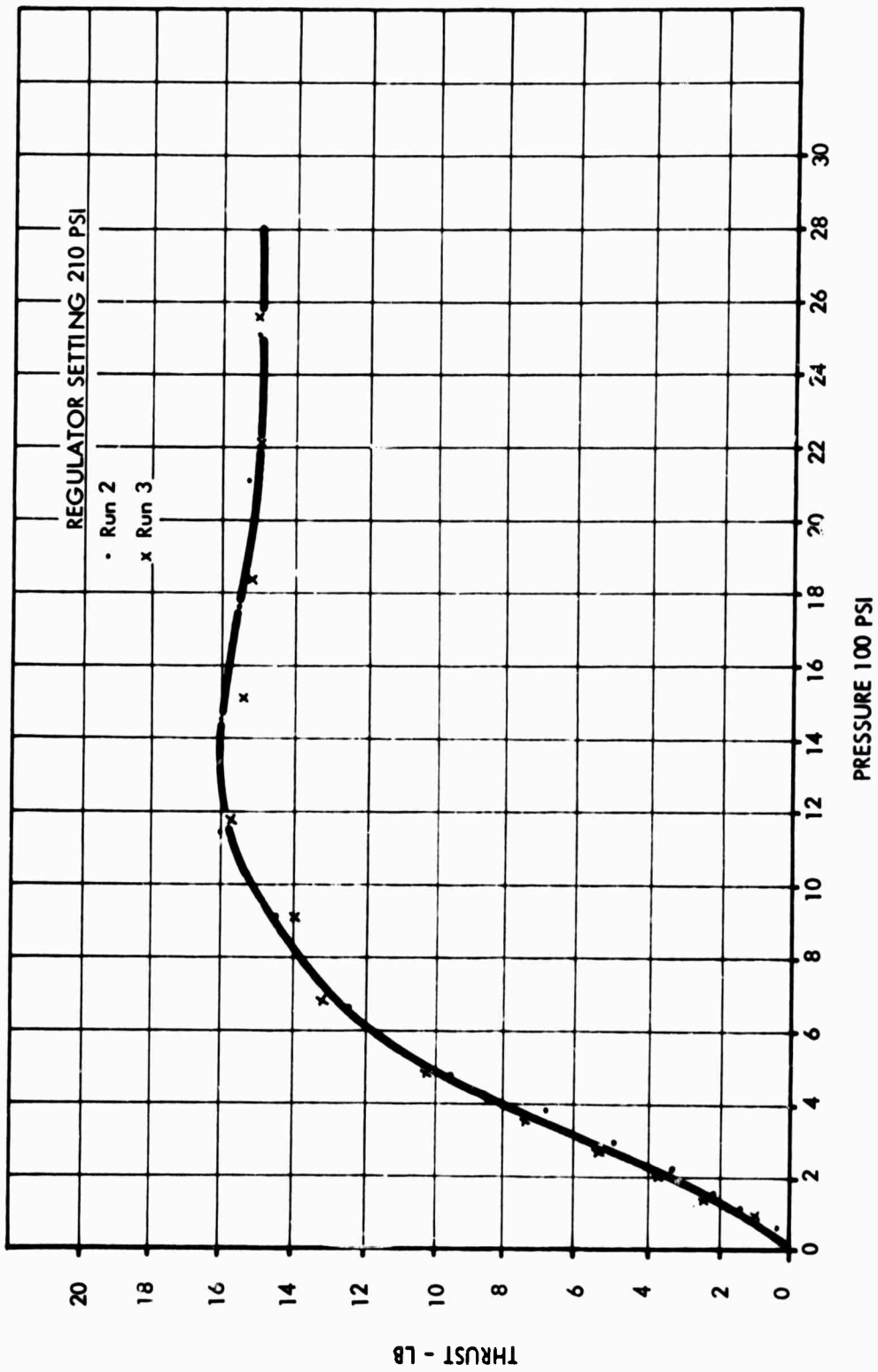

FIGURE 5 - N<sub>2</sub> THRUST VS. PRESSURE - SYSTEM NO. 1

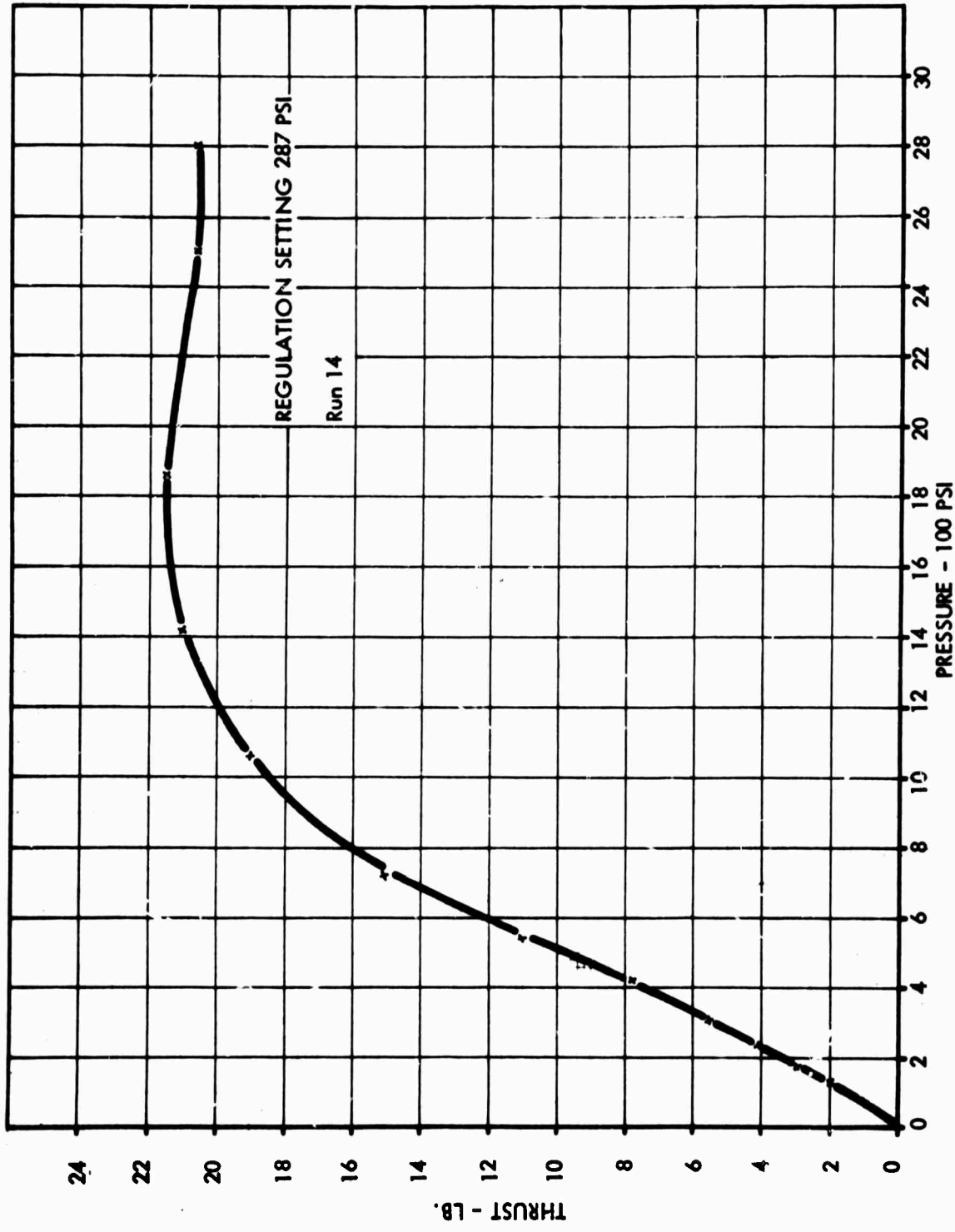

FIGURE 6 - N<sub>2</sub> THRUST VS. PRESSURE - SYSTEM NO. 2

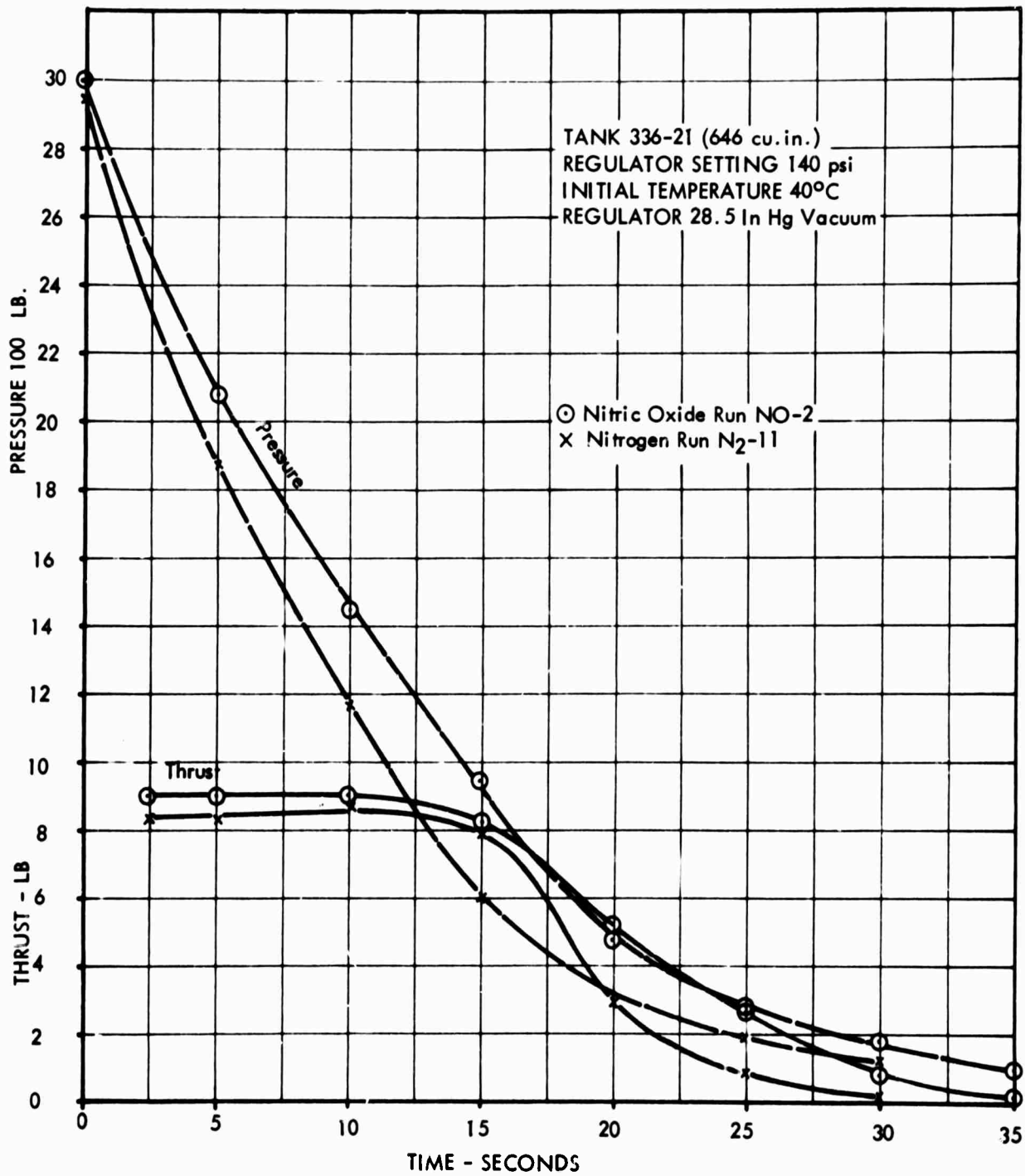

FIGURE 7 - NITRIC OXIDE & NITROGEN THRUST COMPARISON

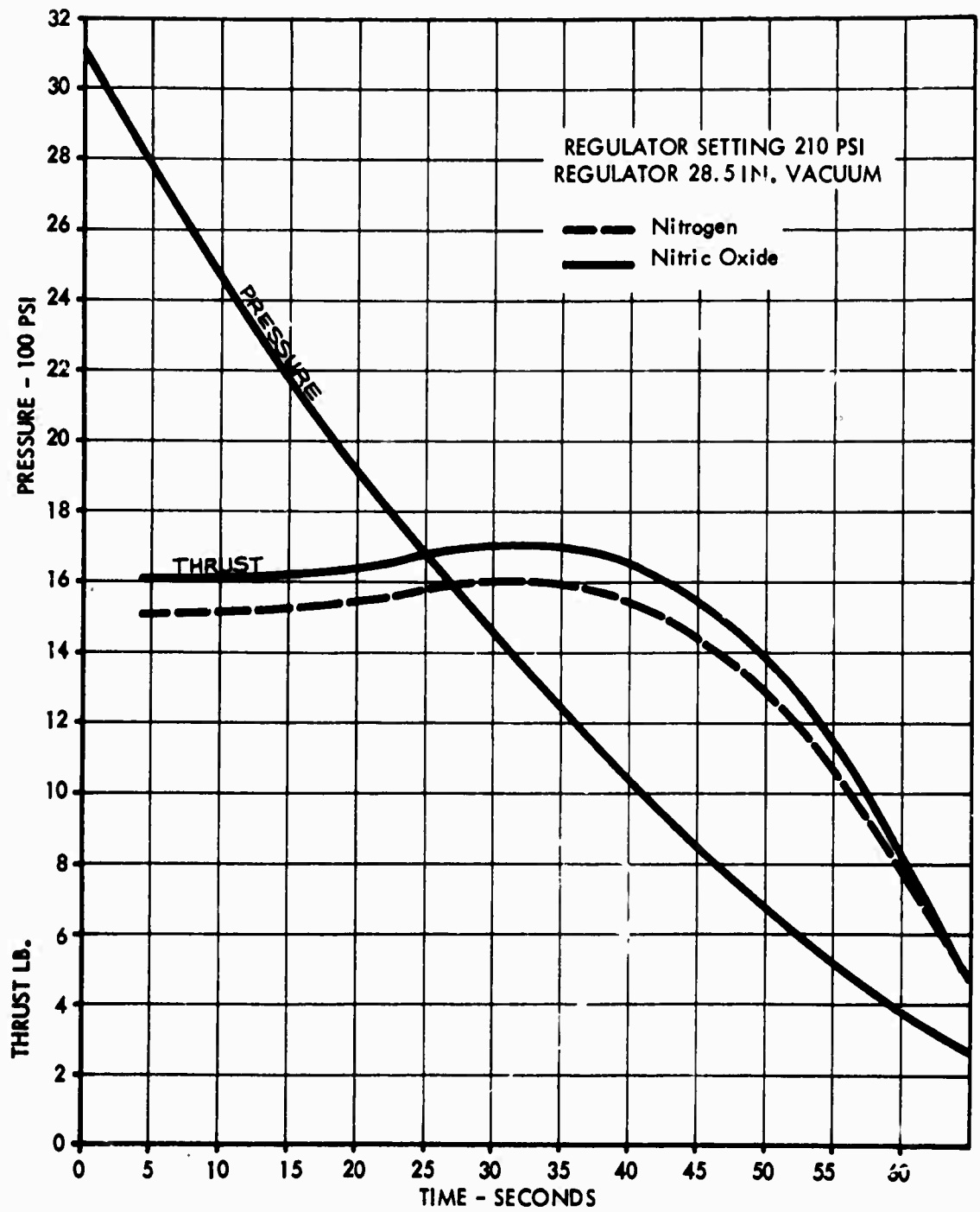

FIGURE 8 - PRESSURE & THRUST VS. TIME - FLIGHT NO. 1

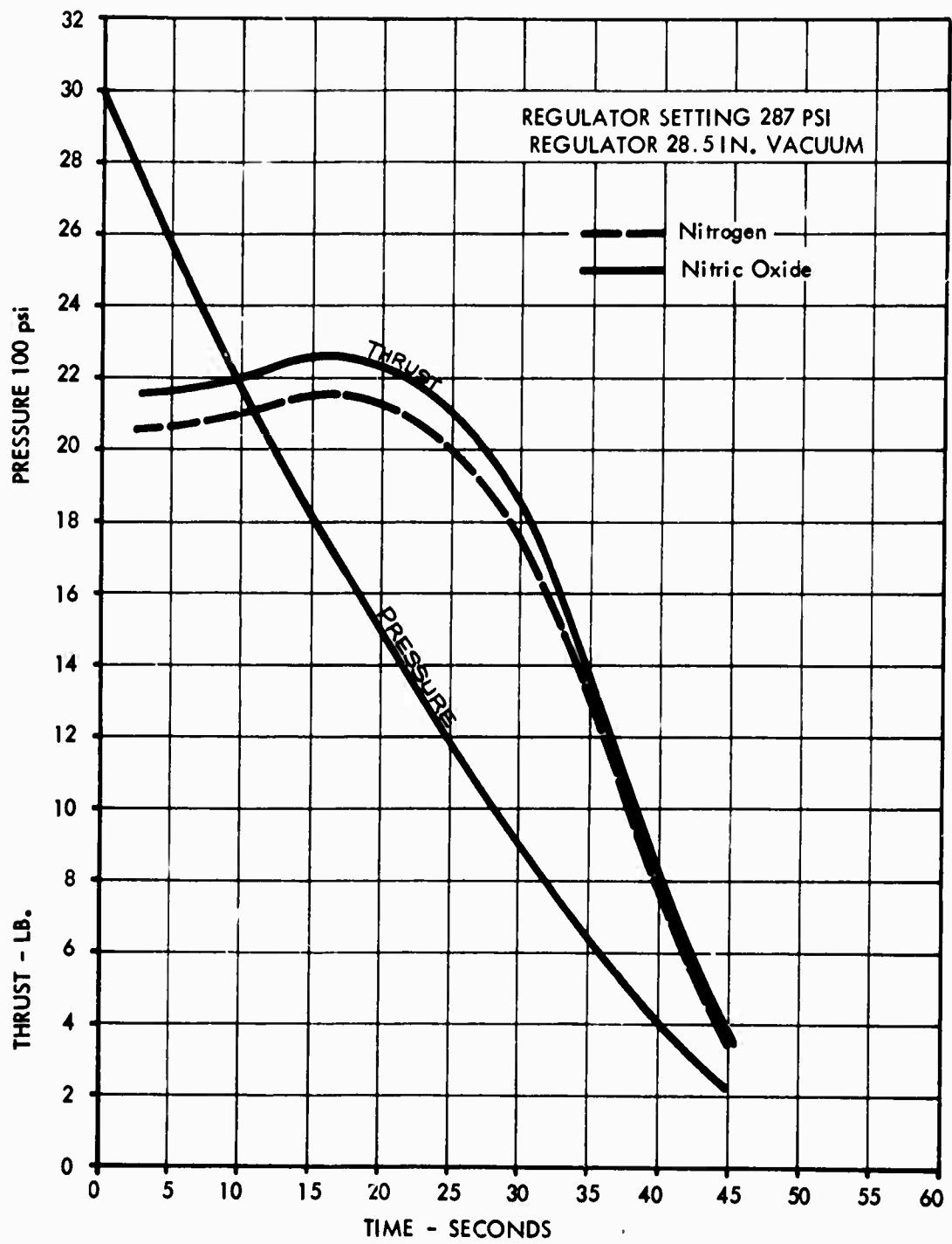
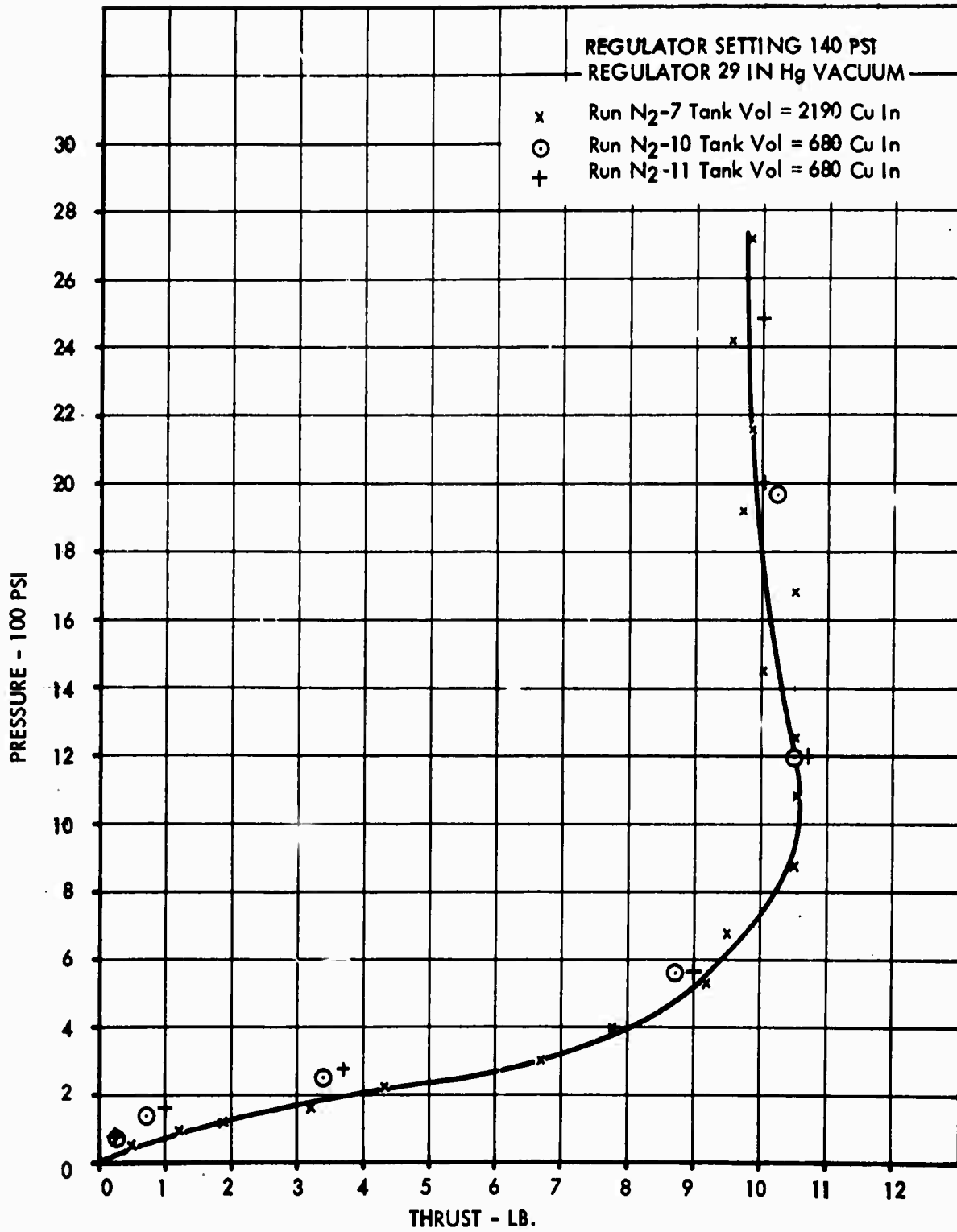

FIGURE 9 - PRESSURE & THRUST VS. TIME - FLIGHT NO. 2

APPENDIX 1

THRUST VERSUS PRESSURE COMPARISON



THRUST VS. PRESSURE COMPARISONS (680 & 2190 Cu In Tanks)

APPENDIX 2

MASS FLOW VERSUS TANK PRESSURE

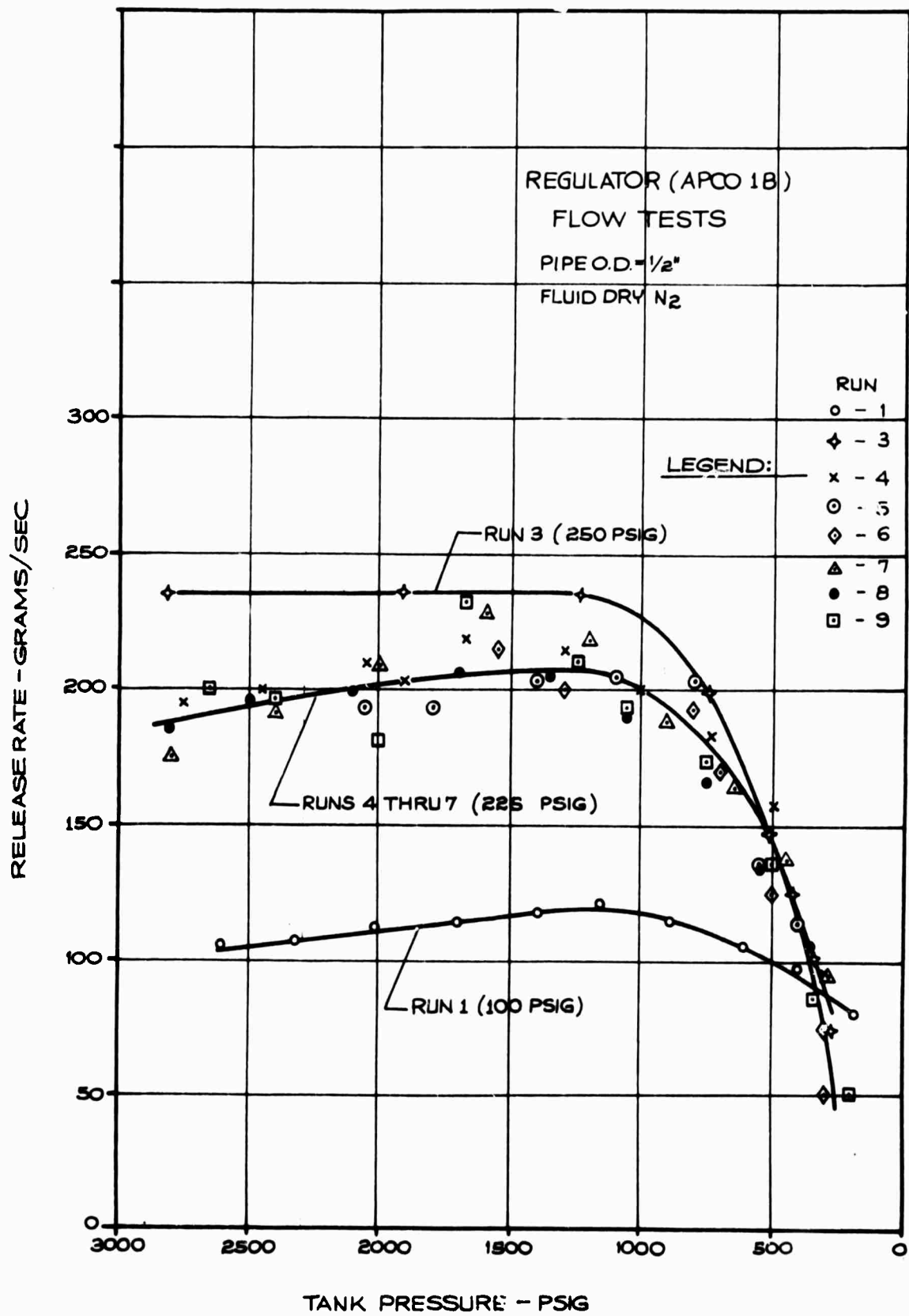

APPENDIX 3

THRUST VERSUS TIME COMPARISON  
WITH REGULATOR AT SEA LEVEL AND IN A VACUUM

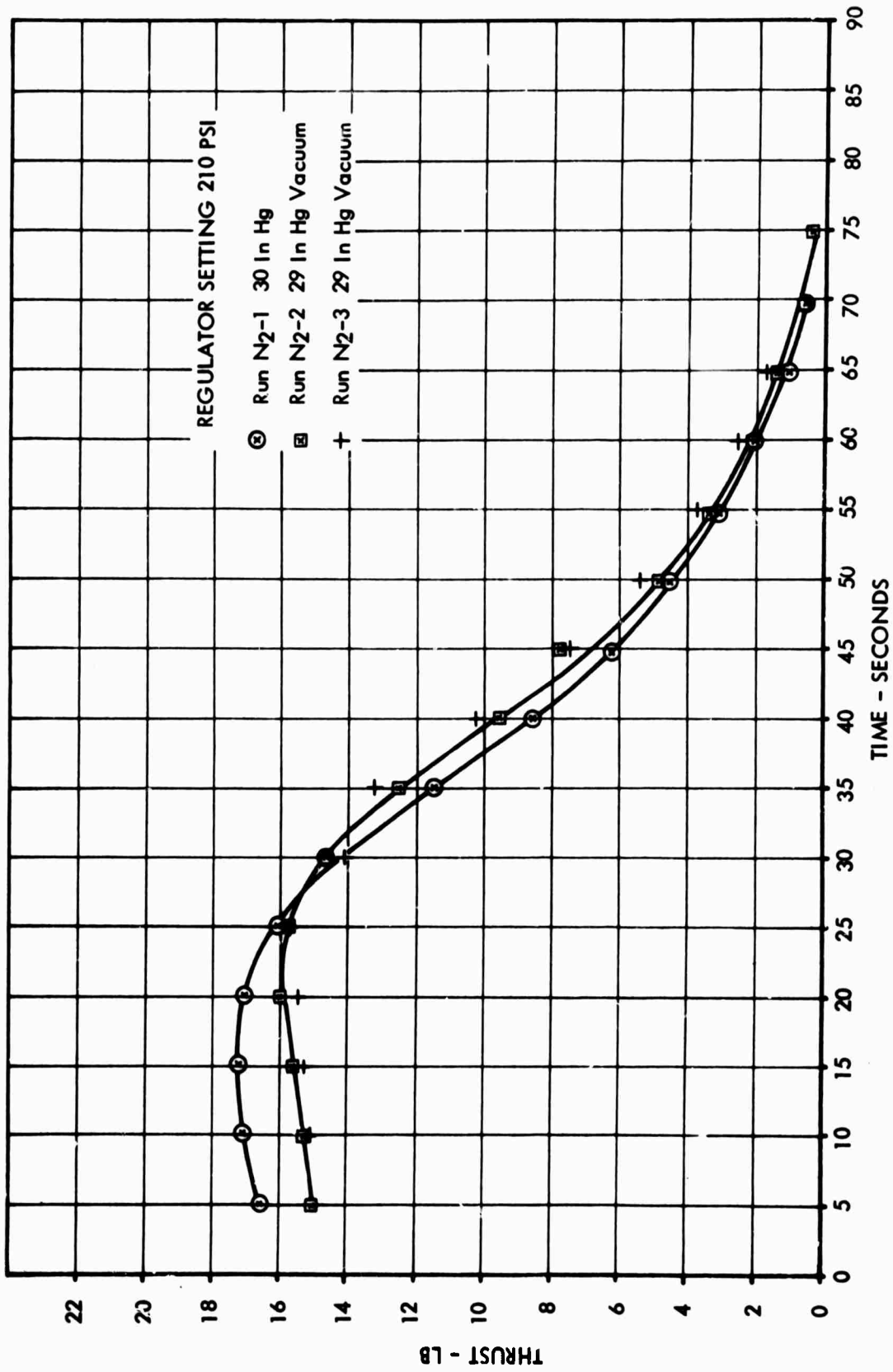

N<sub>2</sub> THRUST VS. TIME COMPARISON REGULATOR IN VACUUM & AMBIENT

APPENDIX C

SQUIB VALVE (273-10) TESTS

## EXPLOSIVE VALVE TEST DATA

SDC P/N 273-10

- 1.0 PRESSURE TESTS
  - 1.1 UNFIRED VALVE PRESSURIZED TO 4500 PSI with N<sub>2</sub>
  - 1.2 FIRED VALVE PRESSURIZED TO 4500 PSI with N<sub>2</sub> AND LEAK  
CHECKED TO 3000 PSI
  - 1.3 FIRED VALVE PRESSURIZED TO BURST AT 5500 PSI with WATER
  - 1.4 NIPPLE P/N 273-11-3 PRESSURIZED TO BURST AT 15,500 PSI  
with WATER
  - 1.5 NIPPLE P/N 273-11-3 PRESSURIZED TO BURST AT 16,000 PSI  
with WATER
- 2.0 ENVIRONMENTAL TESTS
  - 2.1 UNFIRED VALVE WENT THROUGH VIBRATION, SHOCK AND ACCELERATION AND WAS FIRED SUCCESSFULLY AFTER COMPLETION OF TESTS.  
REFERENCE TEST REPORT NO. 3448 GARWOOD LABORATORIES

### 3.0 FUNCTIONAL TESTS

| Number Of Tests | Pressure  | Medium         | Charge              | Squib                 | Flow | Function |
|-----------------|-----------|----------------|---------------------|-----------------------|------|----------|
| 1               | None      | Air            | None                | S-90 <sup>(3)</sup>   | None | Yes      |
| 2               | None      | Air            | 1-2D <sup>(1)</sup> | S-90                  | None | Yes      |
| 1               | None      | Air            | 3-2D                | S-90                  | None | Yes      |
| 2               | None      | Air            | 2-2D                | 209 <sup>(4)</sup>    | None | Yes      |
| 1               | 200 psi   | N <sub>2</sub> | 2-2D                | S-90                  | None | Yes      |
| 30              | 900 psi   | N <sub>2</sub> | 1-2D                | S-90                  | None | Yes      |
| 2               | 3000 psi  | N <sub>2</sub> | 1-2D                | S-90                  | Yes  | Yes      |
| 1               | 3000 psi  | N <sub>2</sub> | 1-2D                | S-90                  | None | No       |
| 10              | 3000 psi  | N <sub>2</sub> | 2-2D                | S-90                  | Yes  | Yes      |
| 1               | None      | Air            | 2-2D                | 101350 <sup>(5)</sup> | None | Yes      |
| 1               | None      | Air            | 1-2D                | 101350                | None | Yes      |
| 1               | 2000 psi  | No             | 2-2D                | S-90                  | Yes  | Yes      |
| 1               | 3000 psi  | No             | 2-2D                | S-90                  | Yes  | Yes      |
| 1               | 2700 psi  | No             | 2-2D                | S-90                  | Yes  | Yes      |
| 1               | 3100 psi  | No             | 2-2D                | S-90                  | Yes  | Yes      |
| 1               | 3200 psi  | N <sub>2</sub> | 2-2D                | S-90                  | Yes  | Yes      |
| 3               | 3000 psi  | N <sub>2</sub> | 2-2D                | S-90                  | Yes  | Yes      |
| 10              | 0-300 psi | N <sub>2</sub> | 2-2D <sup>(2)</sup> | 209                   | Yes  | Yes      |

1\* Arc 2D Boron Potassium Nitrate

2\*\* .27 gm

3. DuPont

4. Arc 1 amp, 1 watt, 5 minute

5 SDI 1 amp, 1 watt, 5 minute

APPENDIX D

TOGGLE AND GENEVA VALVE TESTS

(REFERENCE TM 105)

## TABLE OF CONTENTS

1. INTRODUCTION
2. SCOPE OF TESTS
3. CYCLE PARAMETERS
4. ASSEMBLY CHECKLIST
5. RECOMMENDED DESIGN IMPROVEMENTS
6. DATA REDUCTION PROCEDURE

### FIGURE

1. Performance Data Intermittent Valves (Speed and Aug Release)
2. Test SetUp
3. Toggle Valve
4. Geneva Valve
5. Circuit Diagram (Electrical Interface)
6. Circuit Diagram (Electrical Interface) Space Card Payloads
7. Toggle .35 Sec on No Orifice
8. Toggle .70 Sec on No Orifice
9. Toggle .50 Sec on No Orifice
10. Geneva .90 Sec on .067 Orifice
11. Toggle .70 Sec on .067 Orifice
12. Toggle .35 Sec on .067 Orifice
13. Toggle .50 Sec on .067 Orifice
14. Toggle .50 Sec on .089 Orifice

### TABLE

1. Test Data
2. Test Data
3. Test Data
4. Test Data
5. Test Data
6. Test Data
7. Test Data
8. Test Data
9. Test Data

1. INTRODUCTION.

The objectives of this TM are to describe the present parameters and how they were arrived at for the Toggle and Geneva Intermittent Valve System as applied to the Spare Card program on Contract No. AF 19(628)5125; also to present assembly and pre-launch check-out procedures and to recommend design improvements which will provide more flexible systems in the future.

## 2. SCOPE OF TESTS.

The tests were designed to furnish performance parameters as well as reliability confidence for both systems. A separate test series was run for each valve.

### 2.1 Test Conditions.

Individual Yardney PM-1 batteries were used in series to produce the desired voltage. Each increase in voltage was produced by adding a freshly charged cell to the pack. An AFCRL "08" payload tank was used in conjunction with 4.5 pound kerosene as the working fluid; initial pressure 175 psi N<sub>2</sub> on the gas side. Each valve was run in for about 60 seconds before and after running in the "08" system. On completion of the system runs, each valve was run for 300 seconds on PM-1 batteries and Eveready N57 dry cells in series. These conditions were used to establish reliability of the PM-1 power supply and to get a data point outside the proposed operating limits.

### 3. CYCLE PARAMETERS.

As a result of the test data in Table 1 and the results plotted in Figure 1, the parameters available for the Spare Card program are as follows:

#### 3.1 Toggle Valve.

- 3.1.1 Maximum total cycle time - 2.5 seconds
- 3.1.2 Minimum total cycle time - .9 seconds
- 3.1.3 Maximum operating pressure - 200 psi (cracking pressure on #453 hoke valve is 210 psi.)
- 3.1.4 Total cycle times available - 2.5 seconds, 1.5 seconds, 1.1 seconds, 0.9 seconds.
- 3.1.5 Cam profile requires  $15^{\circ}$  ramp angle to fully open valve. The closing ramp could be less, however, by having them equal, direction of motor rotation due to polarity has no effect on operation of valve.
- 3.1.6 Cam lift required - .040 inches.

#### 3.2 Geneva Valve.

- 3.2.1 Maximum total cycle time - 4.7 seconds
- 3.2.2 Minimum total cycle time - 1.9 seconds
- 3.2.3 Total cycle times available - 4.7 seconds, 3.3 seconds, 2.4 seconds, 1.9 seconds.
- 3.2.4 On time equal to off time, valve actuation time equal to 25% of total cycle time.

4. CHECK LIST.

4.1 Assembly Check List.

- 4.1.1 For Toggle Valve only, install cams for cycle required. \_\_\_\_\_
- 4.1.2 Select battery combination to give required voltage. Use twice the number of batteries required and put two series packs in parallel with each other. Use dummies to fill any space in battery box. \_\_\_\_\_
- 4.1.3 Install batteries, wire to motor (-) to motor pin 54d and (+) to mounting bracket. Run for 60 seconds and compare cycle time with results shown in Figure 1. \_\_\_\_\_
- 4.1.4 Actuate valve to the closed position and on the geneva valve stop the mechanism when crank pin is engaged with a slot in the geneva wheel starting on the open cycle. \_\_\_\_\_
- 4.1.5 Install valve assembly in SDC mounting cylinder. Check for any loose hardware. \_\_\_\_\_
- 4.1.6 Install SDC adapter pipe on conax valve at forward end of "24" payload. \_\_\_\_\_
- 4.1.7 Slip assembly over adapter pipe and at the same time feed wires from timer up through valve assembly. \_\_\_\_\_
- 4.1.8 Connect adapter tube to input side of valve. \_\_\_\_\_
- 4.1.9 Connect (-) battery lead to lead from Pin # 2. \_\_\_\_\_
- 4.1.10 Connect (+) battery lead to lead from Pin # 1. \_\_\_\_\_
- 4.1.11 Voltage across Pin # 1 & Pin # 2 should be 4.5 volts minimum. \_\_\_\_\_

4.1.12 Connect (+) motor lead to battery terminal which will give required voltage per Figure 1. \_\_\_\_\_

4.1.13 Check for no volts on (-) lead from squib. \_\_\_\_\_

4.1.14 Connect (-) lead from squib to (-) lead 54 d on motor. \_\_\_\_\_

4.1.15 Tape all loose wires to bracketry. \_\_\_\_\_

4.2 Prelaunch Check List.

4.2.1 Monitor battery voltage to motor by putting voltmeter across (-) Pin (#) and mounting hardware. \_\_\_\_\_

4.2.2 Monitor battery voltage to programmer per AFCRL procedure. \_\_\_\_\_

5. RECOMMENDED DESIGN IMPROVEMENTS.

5.1 Geneva Valve.

5.1.1 Develop an adjustable constant voltage regulator to permit selection of whole second cycle times.

5.2 Toggle Valves.

5.2.1 Develop an adjustable constant voltage regulator to permit selection of whole second cycle times.

5.2.2 Select an off-the-shelf push type valve which will lend itself to actuation by a single cam.

5.2.3 Select a motor/gear box combination that will yield longer total cycle times.

5.3 General.

5.3.1 Combine Geneva and Toggle systems consisting of:

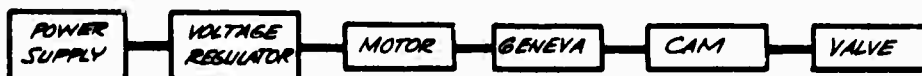

This would yield a total available cycle time of about 10 seconds on minimum voltage with a valve actuation time of about .60 seconds. The system would effectively reduce the speed of the present cam system by a factor of 4. Faster cycles would of course be available by increasing the voltage to the D.C. motor. The net result should be fairly simple, yet extremely flexible device. For example a cycle might be one second on, one second off, two seconds on, six seconds off. The system could also be modified by running two valves off the same cam or different cams and discharging the flow from one valve through an orifice and the other through an atomizing nozzle, thereby giving a comparison of two discharge systems on the same portion of the vehicle trajectory.

6. DATA REDUCTION PROCEDURE.

6.1 Grams Total Curve.

- 6.1.1 Plot points from test data (total on time vs total weight grams).
- 6.1.2 Points should fall on a straight line on log/log paper. The formula for this curve is  $g = ct^n$ .
- 6.1.3 Determine the slope of the curve graphically. This is the value of  $n$ .
- 6.1.4 Using the value of  $n$ , substitute values for  $g$  and  $t$ , then solve for  $c$ .

6.2 Grams/Second Curve.

- 6.2.1 Differentiation of the equation  $g = ct^n$  is  $g' = nct^{n-1}$  which is the equation of the flow rate curve.
- 6.2.2 Using the values of  $n$  and  $c$  from 1.3 and 1.4, substitute values for  $g$  and  $t$ . Two data points will describe the flow rate curve which is also a straight line.

6.3 Cycle Constant Curve.

- 6.3.1 From the test data locate two points on the field by using total on time vs total cycle time.
- 6.3.2 These two points will describe a straight line.

6.4 Interpretation of Curves.

- 6.4.1 To determine the flow rate at any time on the real time scale (which is the time starting when the valve was turned on.) Refer to Figure 7.
- 6.4.2 At a real time of 50 sec, trace in to the cycle constant curve.
- 6.4.3 Trace up to grams/sec. curve and over to read 130 grams/sec.
- 6.4.4 The valve is on for a period of .35 seconds. Therefore the total amount released by a burst at 100 sec., is  $130 \text{ gram/sec} \times .35 \text{ sec} = 45.5 \text{ grams}$ .

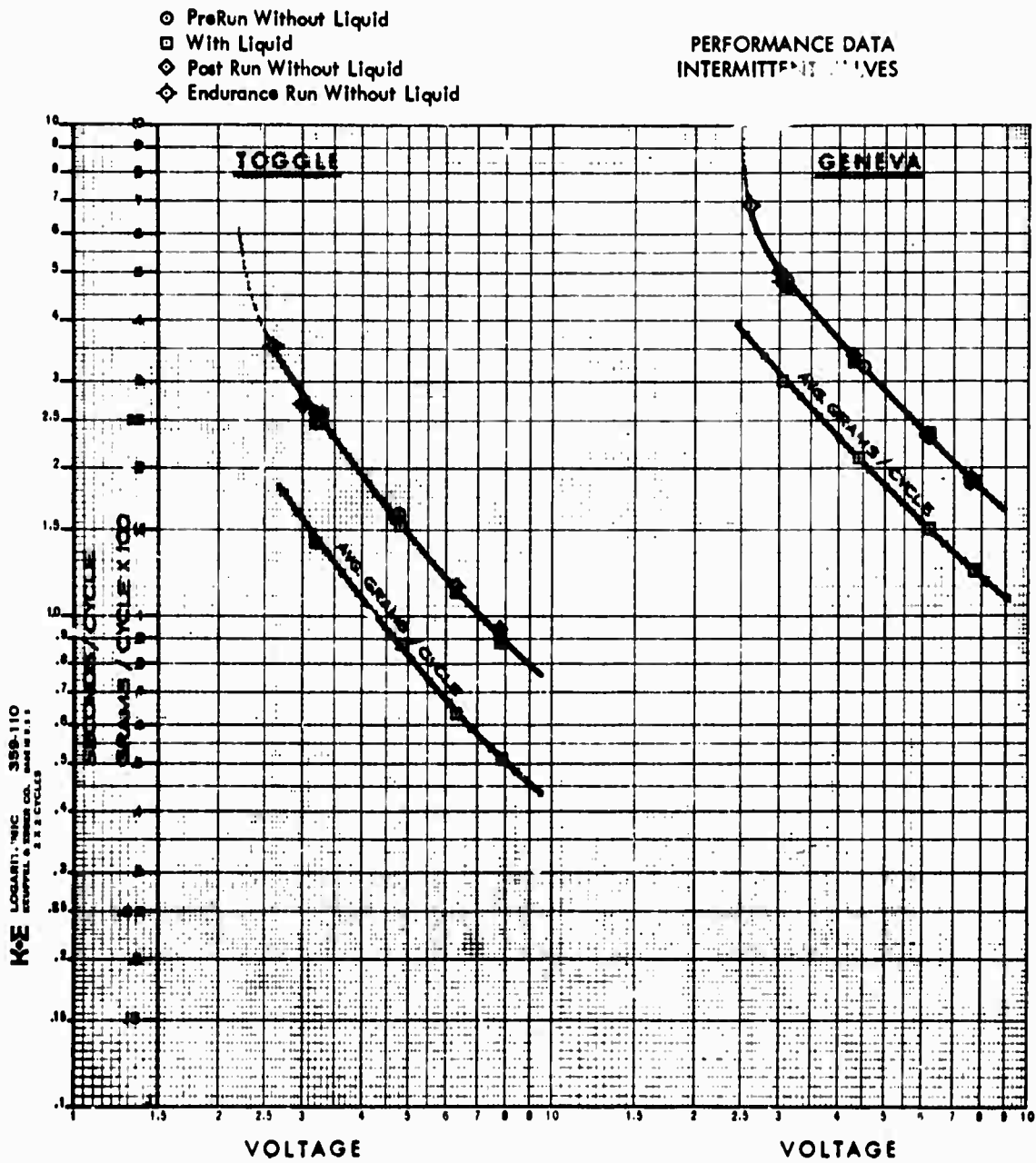

FIGURE 1

A-2011

D-10

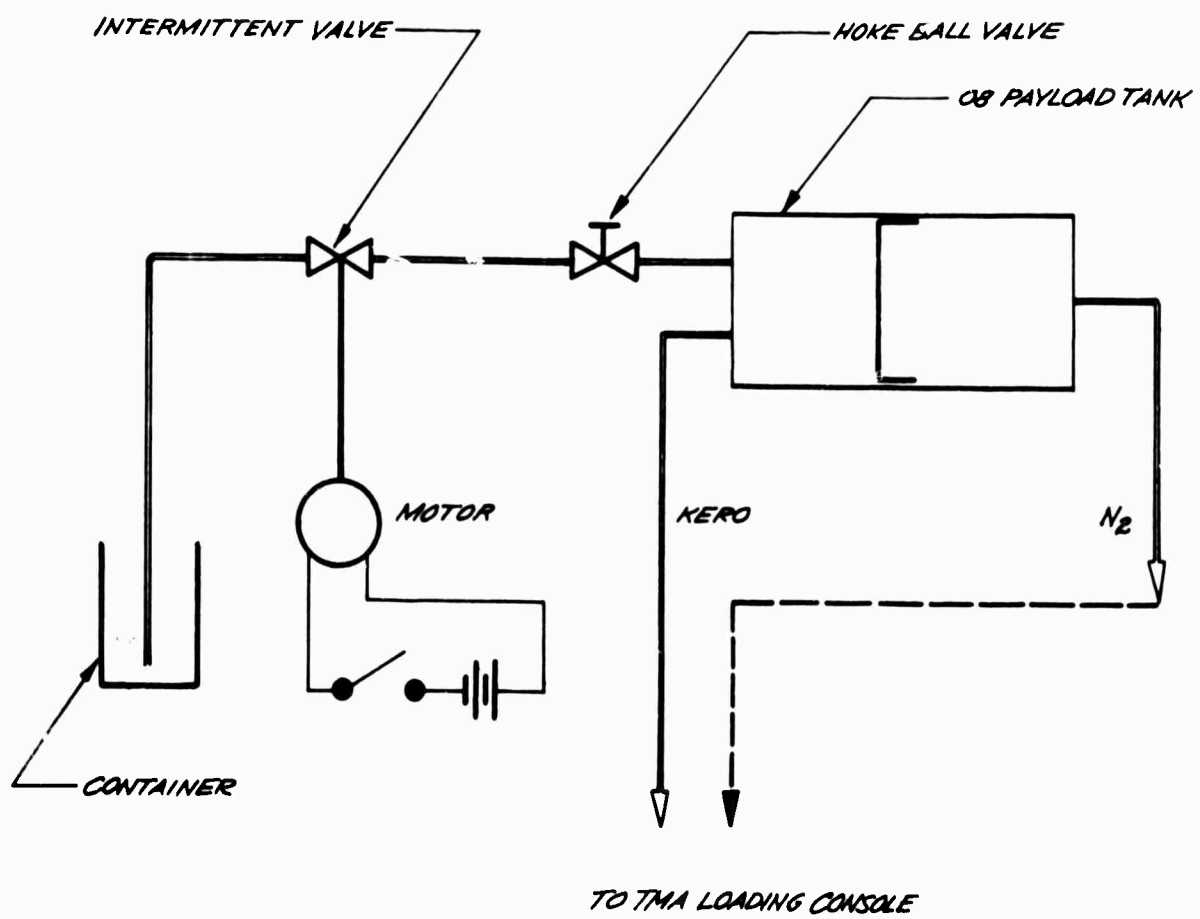
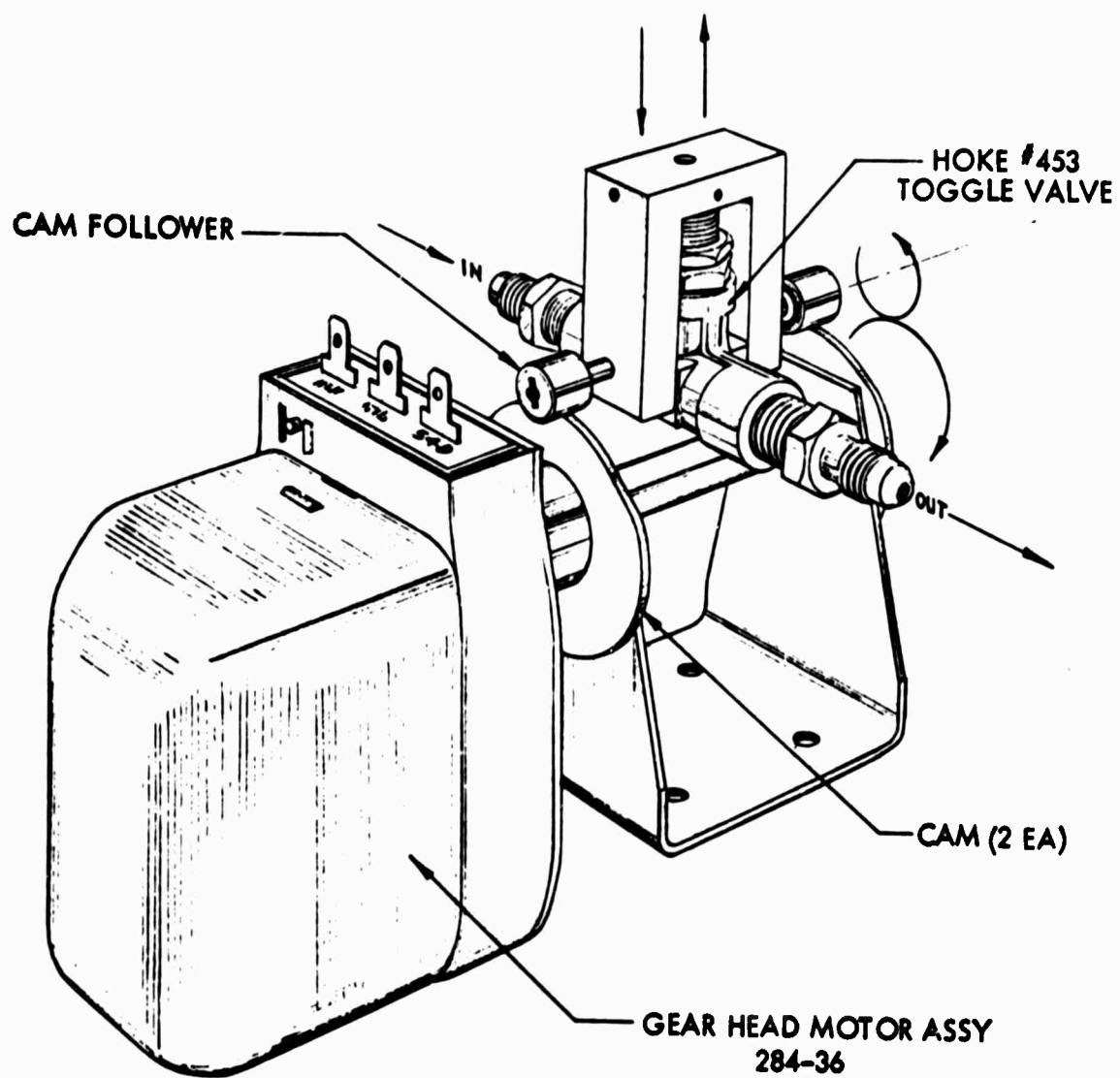
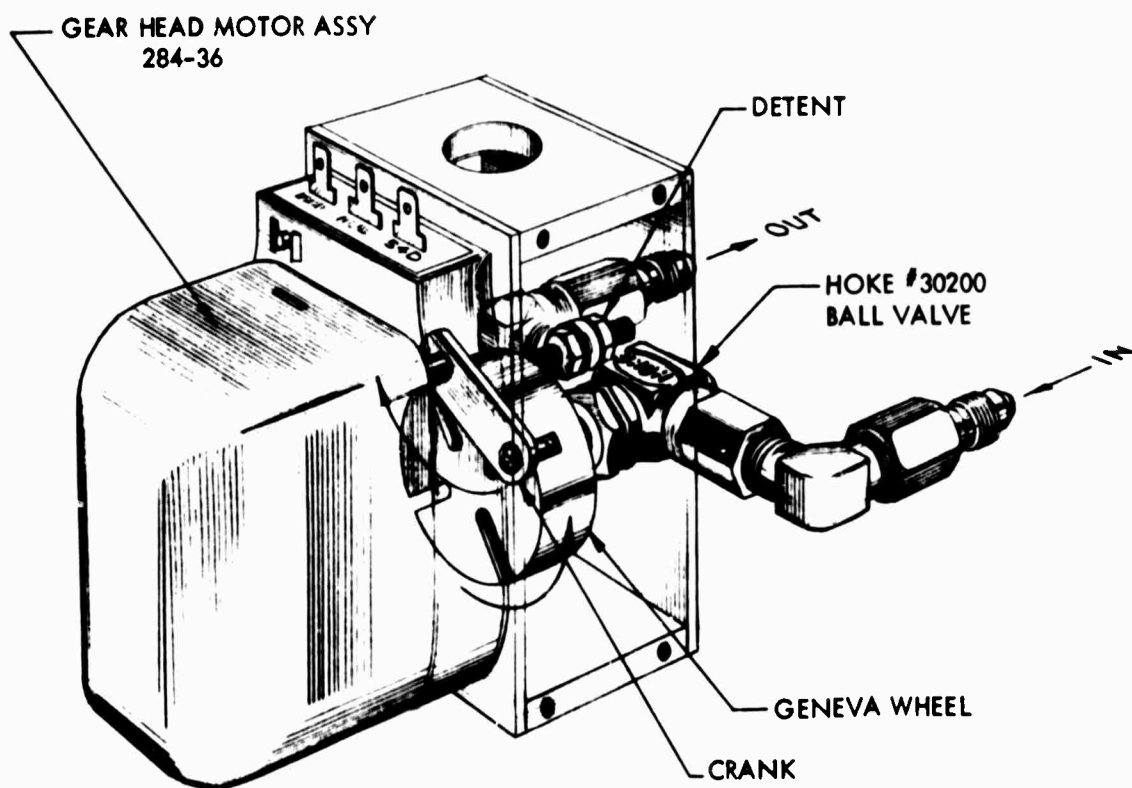

FIGURE 2  
TEST SET UP



TOGGLE VALVE ASSEMBLY

FIGURE 3



GENEVA VALVE ASSEMBLY

FIGURE 4

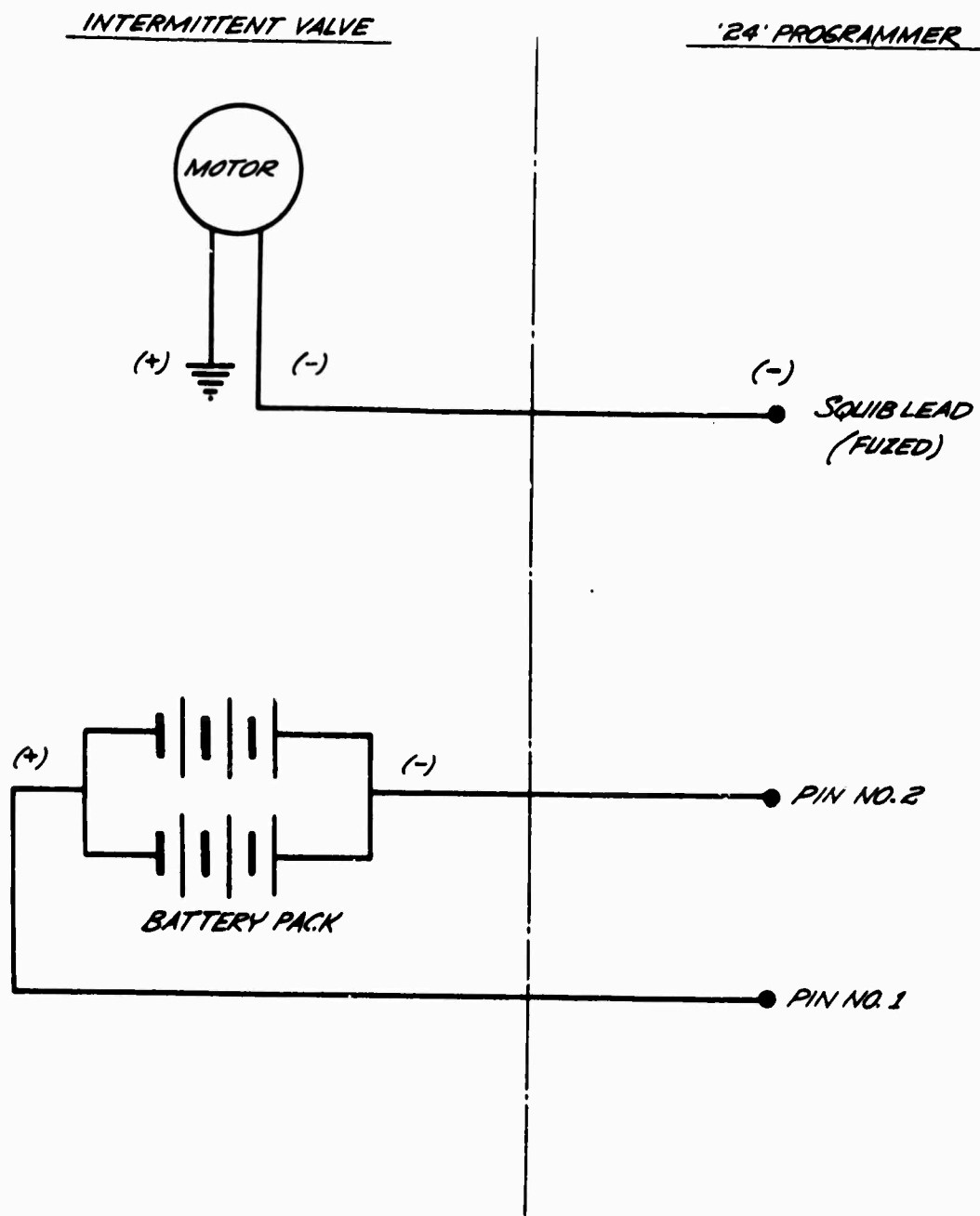

FIGURE 5

CIRCUIT DIAGRAM (ELECTRICAL INTERFACE)

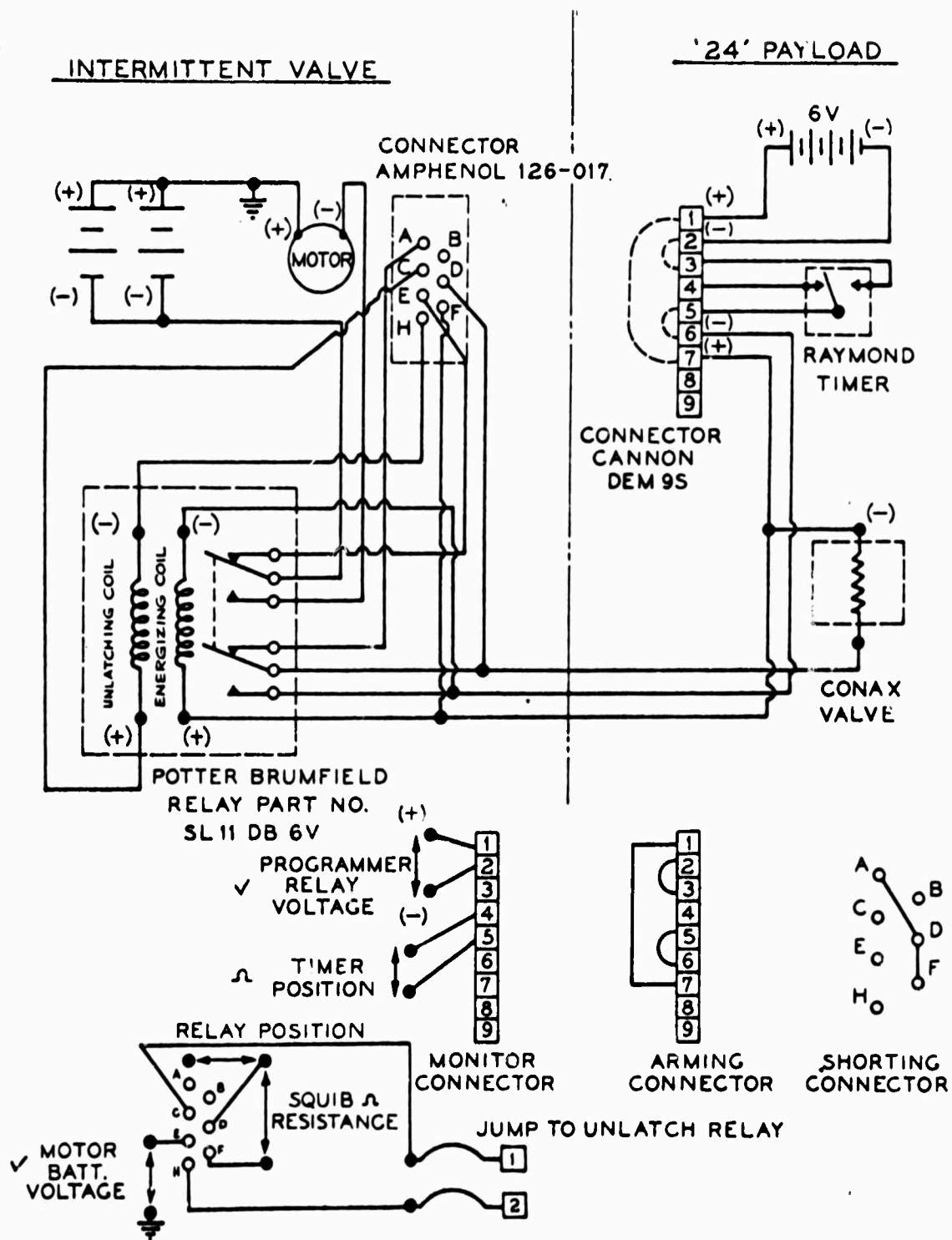

FIGURE 6

FLOW DATA - INTERMITTENT VALVES

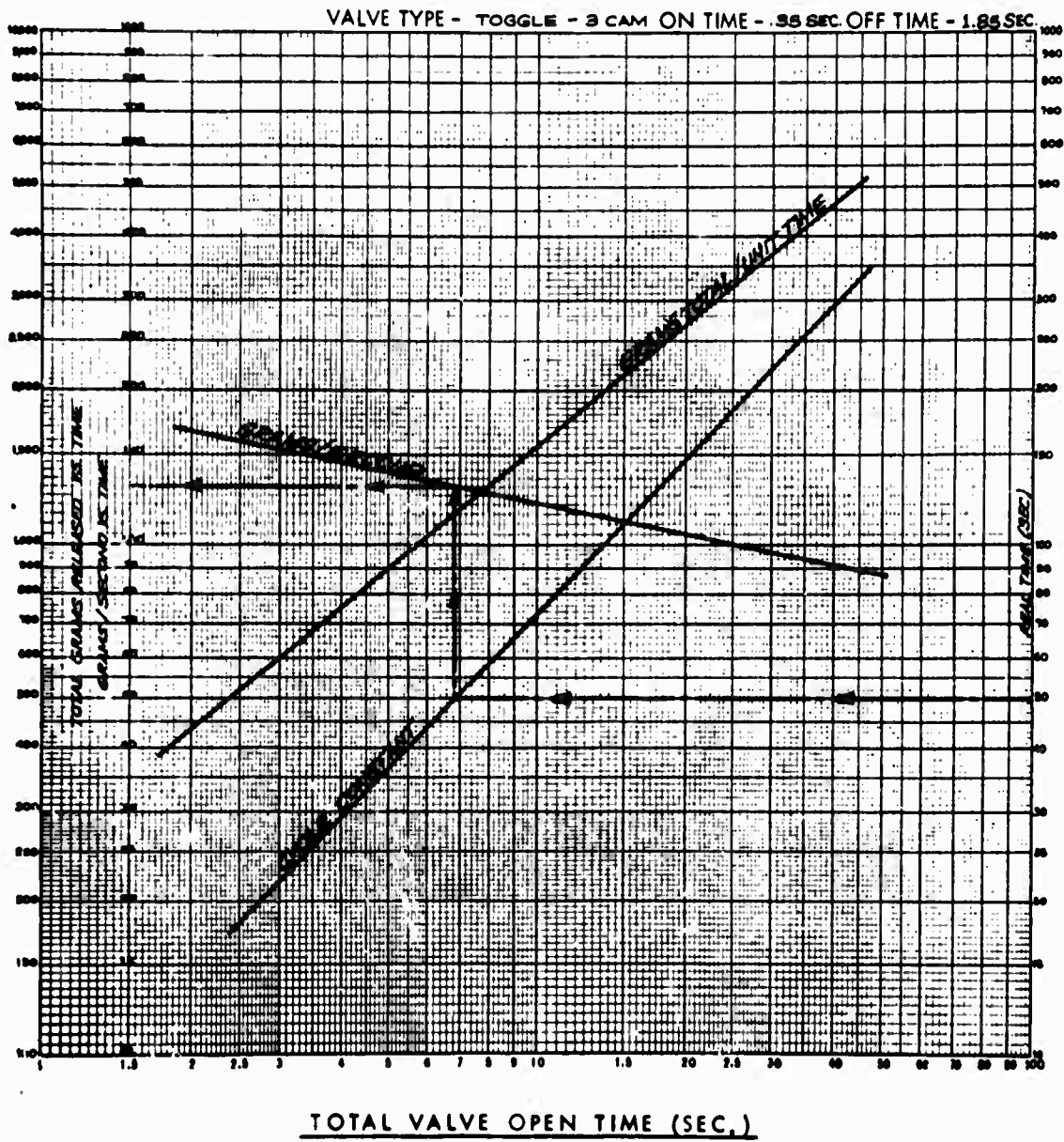

FIGURE 7

A-2015

D-16

FLOW DATA - INTERMITTENT VALVES

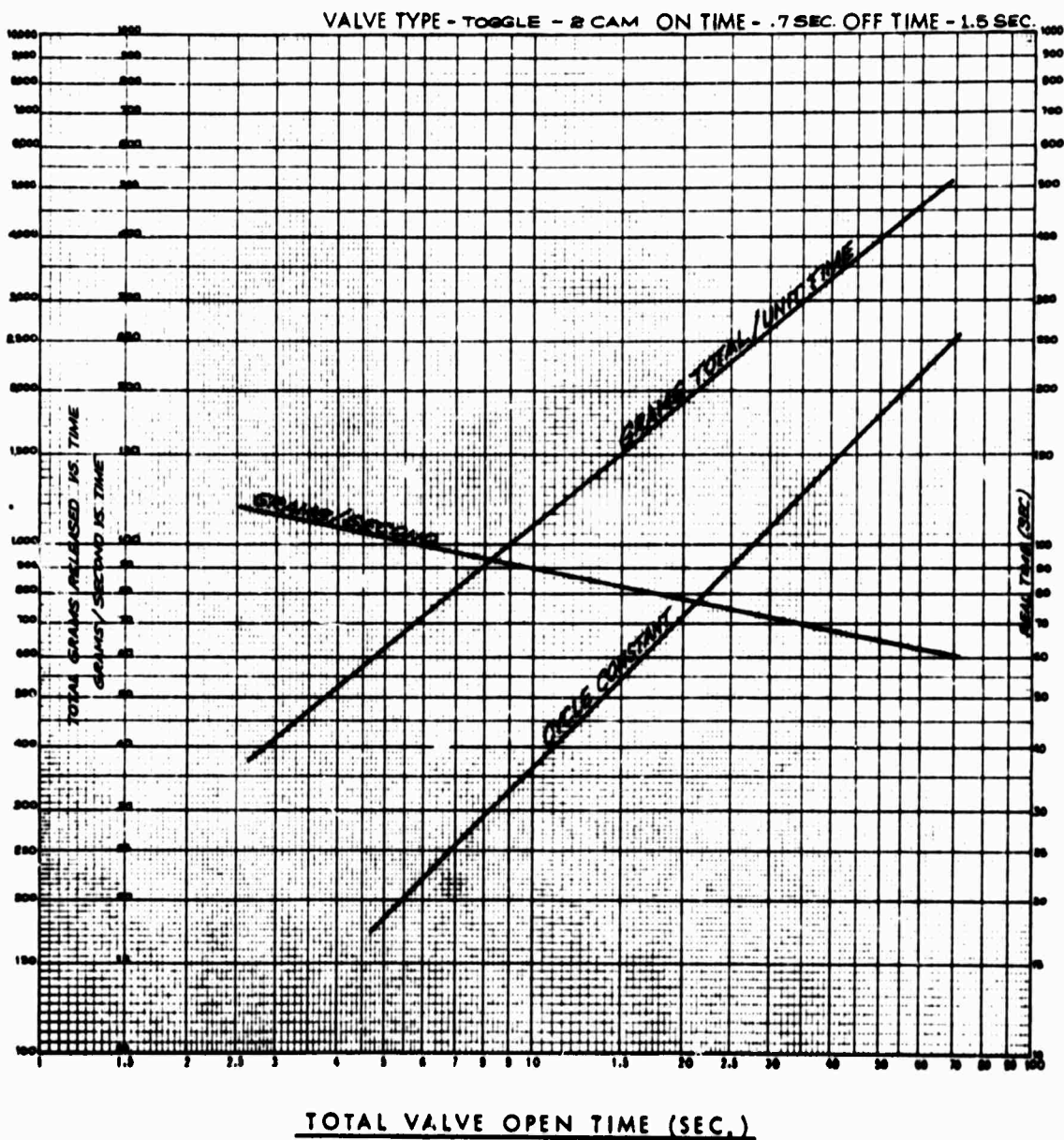

FIGURE 8

A-2016

D-17

FLOW DATA - INTERMITTENT VALVES

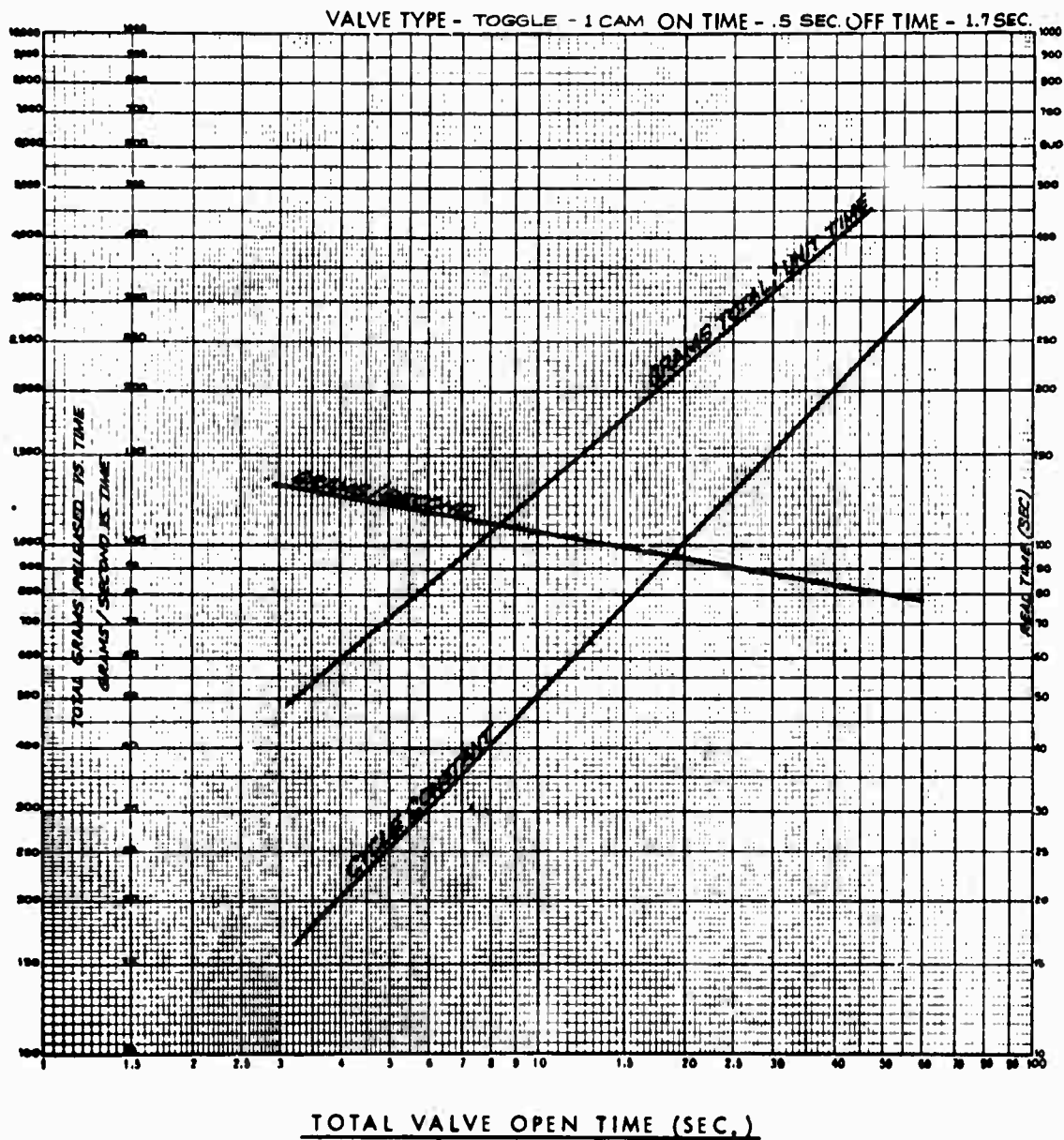

FIGURE 9

A-2017

D-18

FLOW DATA - INTERMITTENT VALVES

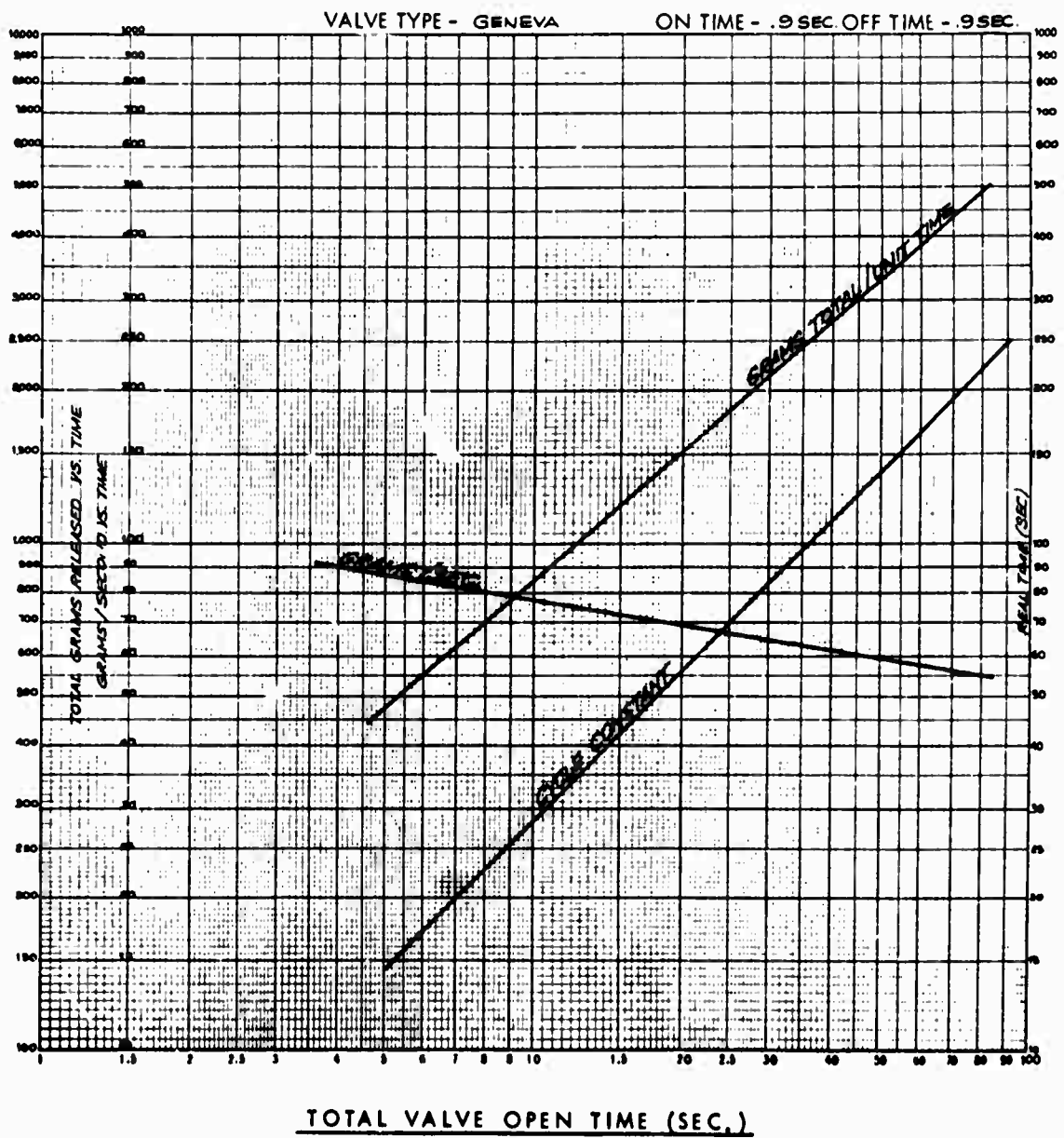

FIGURE 10

A-2018

D-19

FLOW DATA - INTERMITTENT VALVES

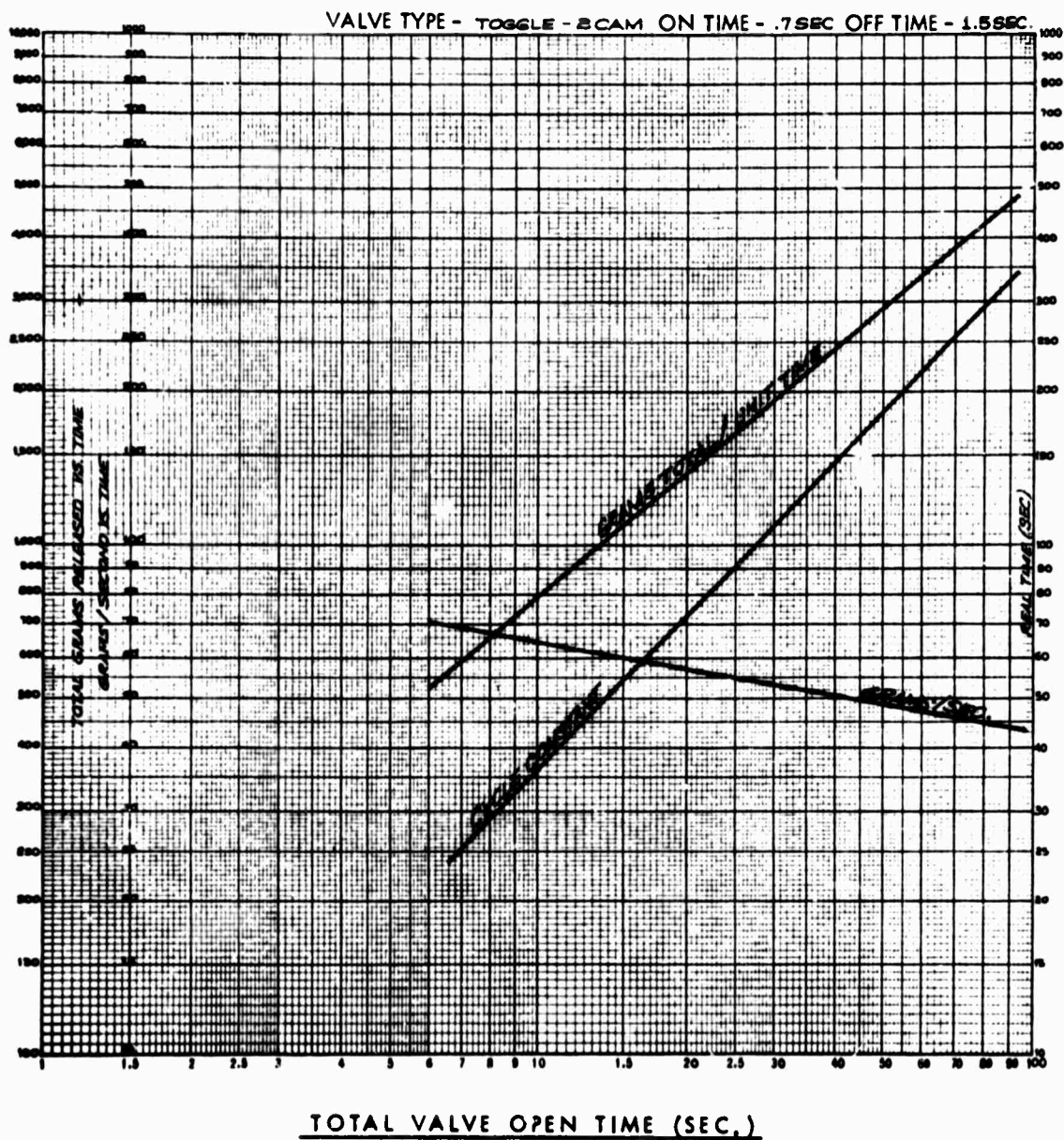

FIGURE 11

A-2019

D-20

FLOW DATA - INTERMITTENT VALVES

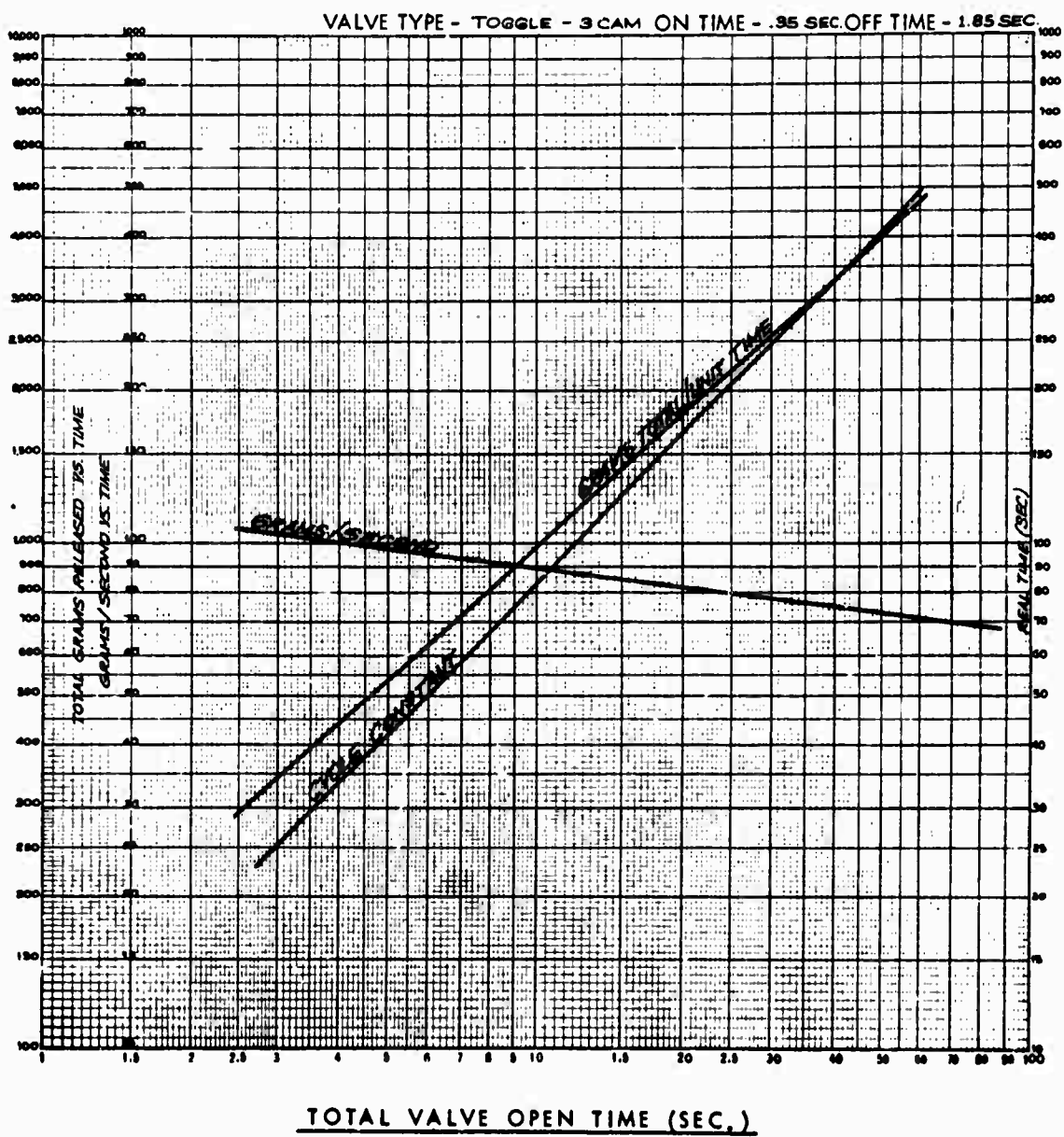

FIGURE 12

A-2020

D-21

FLOW DATA - INTERMITTENT VALVES

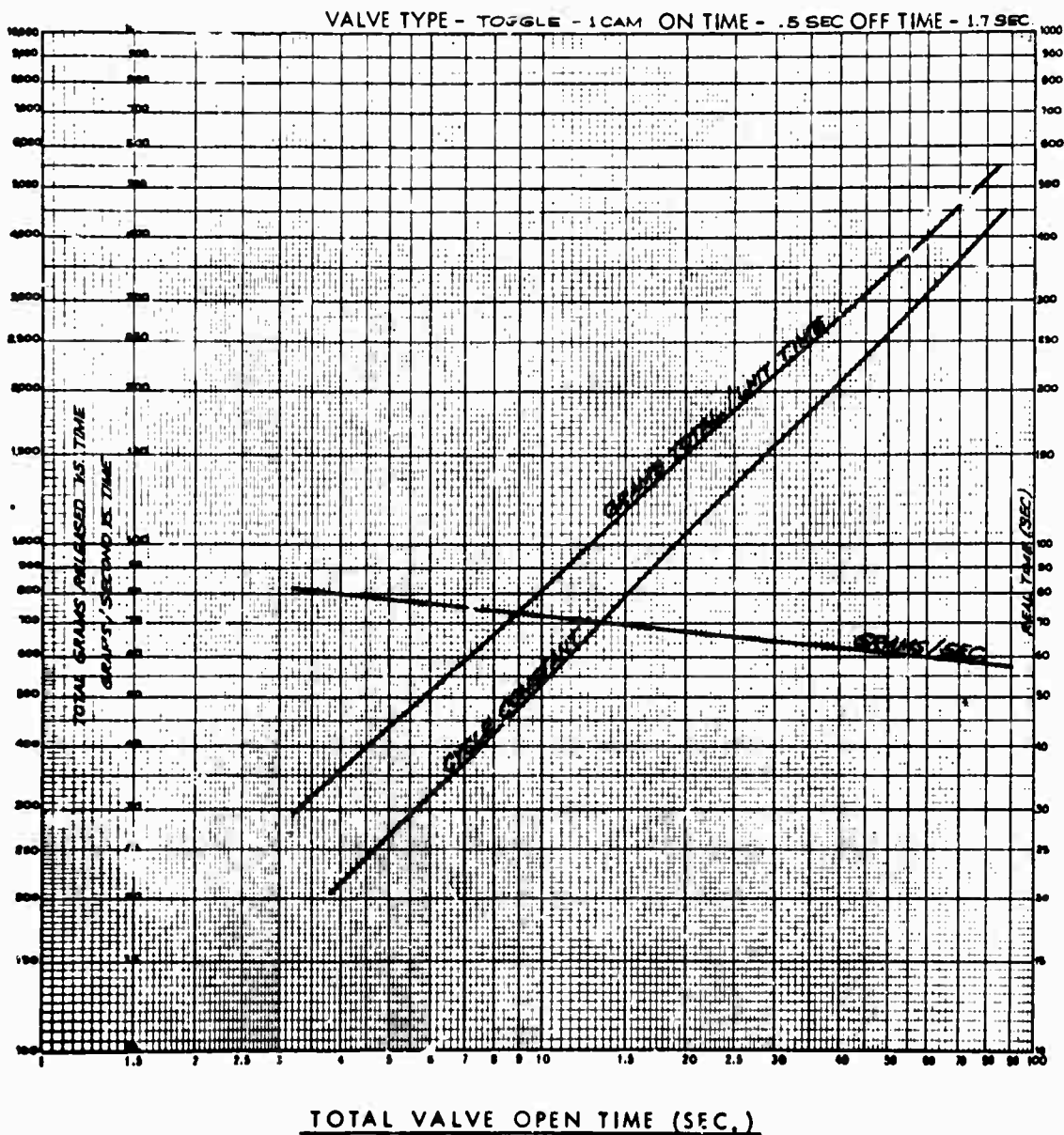

FIGURE 13

A-2021

D-22

FLOW DATA - INTERMITTENT VALVES

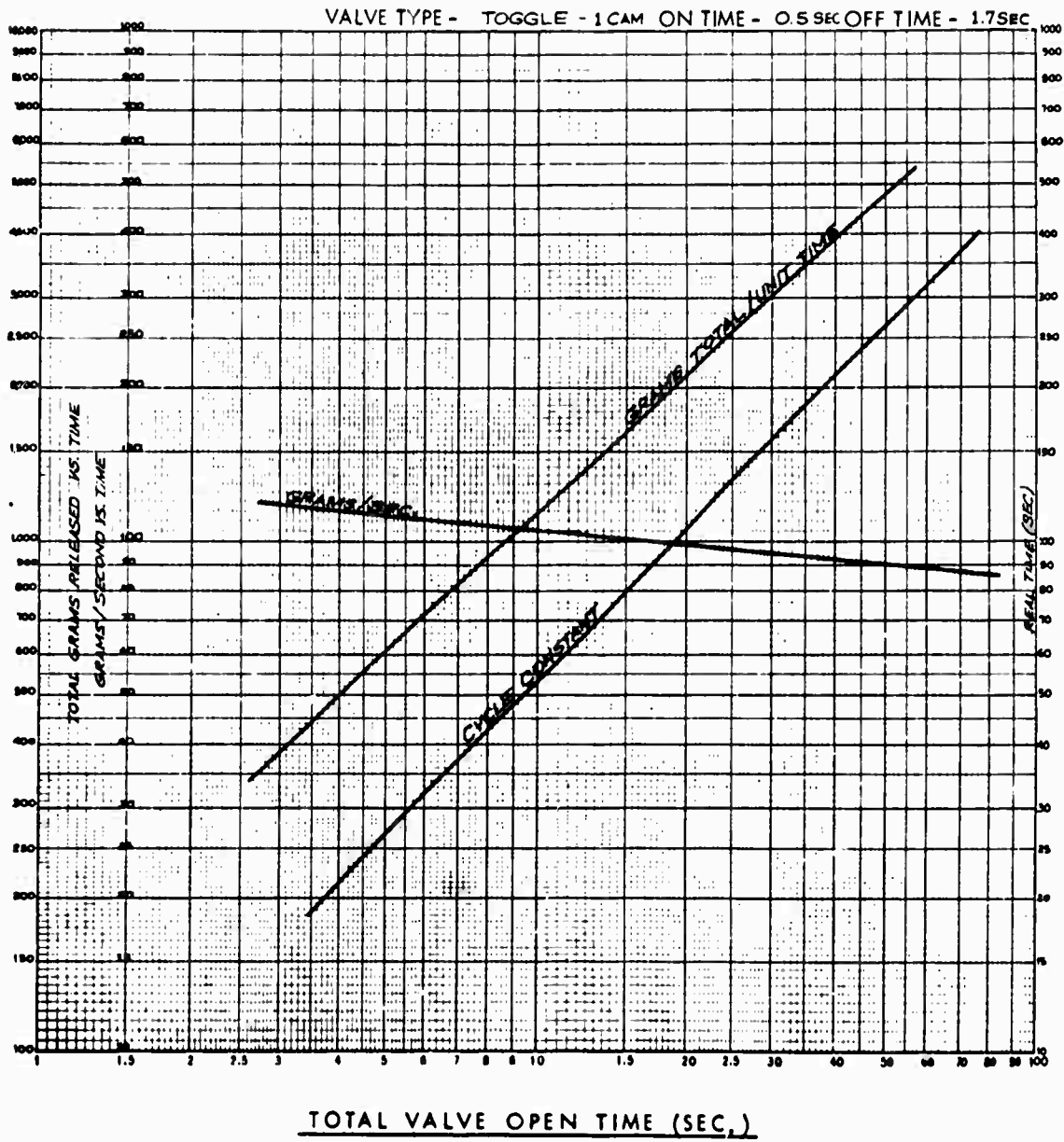

FIGURE 14

A-2022

TABLE 1  
TEST DATA

GENEVA VALVE

| Power Supply | Vi  | Vr  | Vf  | No. of Cycles                | Run Time Seconds | Pf (PSI) | Sec/ Cycle | Grams/ Cycle Average |
|--------------|-----|-----|-----|------------------------------|------------------|----------|------------|----------------------|
| 2-PMI        | 3.8 | 3.1 | 3.7 | 12                           | 58               | 40       | 4.83       | 300                  |
|              | 3.7 | 3.1 | 3.6 | 7                            | 33               |          | 4.72       |                      |
|              | 3.7 | 3.0 | 3.4 | 12                           | 60               |          | 5.00       |                      |
| 3-PMI        | 5.4 | 4.5 | 5.1 | 18                           | 58               | 40       | 3.22       | 210                  |
|              | 5.4 | 4.3 | 5.2 | 10                           | 33               |          | 3.30       |                      |
|              | 5.4 | 4.3 | 5.0 | 18                           | 60               |          | 3.34       |                      |
| 4-PMI        | 7.2 | 6.2 | 6.8 | 24                           | 56               | 45       | 2.33       | 150                  |
|              | 7.2 | 6.2 | 6.8 | 14                           | 33               |          | 2.36       |                      |
|              | 7.0 | 6.1 | 6.8 | 26                           | 61               |          | 2.35       |                      |
| 5-PMI        | 8.7 | 7.6 | 8.5 | 32                           | 60               | 40       | 1.88       | 124                  |
|              | 8.6 | 7.6 | 8.2 | 17                           | 32               |          | 1.88       |                      |
|              | 8.6 | 7.5 | 8.3 | 30                           | 57               |          | 1.90       |                      |
| 2-PMI        | 3.7 | 3.0 | 3.3 | 300<br>14 in last 60 seconds |                  |          | 4.85       |                      |
| 2-N57        | 2.7 | 2.6 | 2.7 | 300<br>8 in last 55 seconds  |                  |          | 6.88       |                      |



TABLE 3  
TEST DATA

| Container No.  | Total Weight (pounds) |                | Total Weight (Grams) |        | No of Puffs      | Total On Time (sec) |              | Total Off Time (sec) |
|----------------|-----------------------|----------------|----------------------|--------|------------------|---------------------|--------------|----------------------|
| 1              | 1.0                   | 1.0            | 453.6                | 453.6  | 5                | 3.5                 | 3.5          | 12.9                 |
| 2              | 0.85                  | 1.85           | 385.6                | 839.2  | 5                | 3.5                 | 7.0          | 25.8                 |
| 3              | 0.77                  | 2.62           | 349.3                | 1188.5 | 5                | 3.5                 | 10.5         | 38.7                 |
| 4              | 0.70                  | 3.32           | 317.5                | 1506.0 | 5                | 3.5                 | 14.0         | 51.6                 |
| 5              | 0.65                  | 3.97           | 294.8                | 1800.8 | 5                | 3.5                 | 17.5         | 64.5                 |
| 6              | 0.60                  | 4.57           | 272.2                | 8073.0 | 5                | 3.5                 | 21.0         | 77.4                 |
| 7              | 0.55                  | 5.12           | 249.5                | 2322.5 | 5                | 3.5                 | 24.5         | 90.3                 |
| 8              | 0.53                  | 5.65           | 240.4                | 2562.9 | 5                | 3.5                 | 28.0         | 103.2                |
| 9              | 0.50                  | 6.15           | 226.8                | 2789.7 | 5                | 3.5                 | 31.5         | 116.1                |
| 10             | 0.48                  | 6.63           | 217.7                | 3007.4 | 5                | 3.5                 | 35.0         | 129.0                |
| 11             | 0.42                  | 7.05           | 190.5                | 3197.9 | 5                | 3.5                 | 38.5         | 141.9                |
| 12             | 1.32                  | 7.37           | 145.2                | 3343.1 | 5                | 3.5                 | 42.0         | 154.8                |
| 13             | 0.15                  | 7.52           | 68.0                 | 3343.8 | 2                | 1.4                 | 43.4         | 160.0                |
| Valve Type     |                       | Toggle - 2 Cam |                      |        | Orifice          |                     | None 1.4" Cu |                      |
| On Time (Sec)  |                       | 0.70           |                      |        | Initial Pressure |                     | 175 PSI      |                      |
| Off Time (sec) |                       | 1.5            |                      |        | No. of Cycles    |                     | 62           |                      |
| VIVrVf(Volts)  |                       | 3.53.13.2      |                      |        | Run Time         |                     | 160          |                      |
| Payload Type   |                       | 24             |                      |        | Sec. per Cycle   |                     | 2.58         |                      |
| Kero Wt. (Lb)  |                       | 7.53           |                      |        |                  |                     |              |                      |

TABLE 4  
TEST DATA

| Container No.  | Total Weight Pounds |                | Total Weight Grams |      | No. of           | Total On Time (sec) |              | Total Cycle Time (Sec) |
|----------------|---------------------|----------------|--------------------|------|------------------|---------------------|--------------|------------------------|
| 1              | 1.3                 | 1.3            | 590                | 590  | 8                | 4.0                 | 4.0          | 20.3                   |
| 2              | 1.1                 | 2.4            | 499                | 1089 | 8                | 4.0                 | 8.0          | 40.6                   |
| 3              | 1.0                 | 3.4            | 454                | 1542 | 8                | 4.0                 | 12.0         | 60.9                   |
| 4              | 0.9                 | 4.3            | 408                | 1950 | 8                | 4.0                 | 16.0         | 81.2                   |
| 5              | 0.8                 | 5.1            | 363                | 2313 | 8                | 4.0                 | 20.0         | 101.5                  |
| 6              | 0.75                | 5.85           | 340                | 2654 | 8                | 4.0                 | 24.0         | 121.8                  |
| 7              | 0.72                | 6.57           | 326                | 2980 | 8                | 4.0                 | 28.0         | 142.1                  |
| 8              | 0.68                | 7.25           | 308                | 3289 | 8                | 4.0                 | 32.0         | 162.4                  |
| 9              | 0.33                | 7.58           | 150                | 3438 | 3                | 1.5                 | 33.5         | 170.0                  |
| Valve Type     |                     | Toggle - 1 Cam |                    |      | Orifice          |                     | None 1.4" Cu |                        |
| On Time (sec)  |                     | 0.5            |                    |      | Initial Pressure |                     | 175 PSI      |                        |
| Off Time (sec) |                     | 1.7            |                    |      | No. of Cycles    |                     | 67           |                        |
| ViVrVf (Volts) |                     | 3.33.13.2      |                    |      | Run Time         |                     | 170          |                        |
| Payload Type   |                     | 24             |                    |      | Sec. per Cycle   |                     | 2.54         |                        |
| Kero Wt. (Lb)  |                     | 7.58           |                    |      |                  |                     |              |                        |

TABLE 5  
TEST DATA

| Container No.           | Total Weight Pounds |           | Total Weight Grams |      | No. of Puffs         | Total On Time (sec) |      | Total Off Time (sec) |
|-------------------------|---------------------|-----------|--------------------|------|----------------------|---------------------|------|----------------------|
| 1                       | 1.4                 | 1.4       | 635                | 635  | 8                    | 7.2                 | 7.2  | 20.6                 |
| 2                       | 1.3                 | 2.7       | 590                | 1225 | 8                    | 7.2                 | 14.4 | 41.2                 |
| 3                       | 1.1                 | 3.8       | 499                | 1724 | 8                    | 7.2                 | 21.6 | 61.8                 |
| 4                       | 1.0                 | 4.8       | 454                | 2177 | 8                    | 7.2                 | 28.8 | 82.4                 |
| 5                       | 0.93                | 5.73      | 422                | 2600 | 8                    | 7.2                 | 36.0 | 103.0                |
| 6                       | 0.90                | 6.63      | 408                | 3007 | 8                    | 7.2                 | 43.2 | 123.6                |
| 7                       | 0.86                | 7.49      | 390                | 3397 | 8                    | 7.2                 | 50.4 | 144.2                |
| 8                       | 0.81                | 8.30      | 367                | 3765 | 8                    | 7.2                 | 57.6 | 164.8                |
| 9                       | 0.50                | 8.80      | 227                | 3992 | 6                    | 5.4                 | 63.0 | 180.2                |
| <b>Valve Type</b>       |                     | Geneva    |                    |      | <b>Run Time</b>      |                     | 180  |                      |
| <b>On Time (Sec)</b>    |                     | 0.9       |                    |      | <b>Sec per Cycle</b> |                     | 2.58 |                      |
| <b>Off Time (Sec)</b>   |                     | 0.9       |                    |      |                      |                     |      |                      |
| <b>ViVrVf (Volts)</b>   |                     | 6.66.06.3 |                    |      |                      |                     |      |                      |
| <b>Payload Type</b>     |                     | 24        |                    |      |                      |                     |      |                      |
| <b>Kero Wt. (Lb)</b>    |                     | 8.8       |                    |      |                      |                     |      |                      |
| <b>Orifice</b>          |                     | 0.67      | 0.67               |      |                      |                     |      |                      |
| <b>Initial Pressure</b> |                     | 190 PSI   |                    |      |                      |                     |      |                      |
| <b>No. of Cycles</b>    |                     | 70        |                    |      |                      |                     |      |                      |

TABLE 6  
TEST DATA

| Container No.   | Total Weight Pounds |      | Total Weight Grams |      | No. of Puffs | Total On Time (sec) |      | Total Off Time (sec) |
|---|---------------------|------|--------------------|------|--------------|---------------------|------|----------------------|
| 1   | 1.6                 | 1.6  | 726                | 726  | 14           | 9.8                 | 9.8  | 36.2                 |
| 2   | 1.4                 | 3.0  | 635                | 1361 | 14           | 9.8                 | 19.6 | 72.2                 |
| 3   | 1.25                | 4.25 | 567                | 1928 | 14           | 9.8                 | 29.4 | 108.4                |
| 4   | 1.15                | 5.4  | 522                | 2449 | 14           | 9.8                 | 39.2 | 144.5                |
| 5   | 1.10                | 6.5  | 499                | 2948 | 14           | 9.8                 | 49.0 | 180.6                |
| 6   | 0.93                | 7.43 | 422                | 3370 | 14           | 9.8                 | 58.8 | 216.7                |
| 7   | 0.80                | 8.23 | 363                | 3733 | 14           | 9.8                 | 68.6 | 252.8                |
| 8   | 0.56                | 8.79 | 254                | 3987 | 11           | 7.7                 | 76.3 | 281.2                |
| <p>Valve Type            Toggle - 2 Cam</p> <p>On Time (Sec)        0.7</p> <p>Off Time (sec)        1.5</p> <p>ViVrVf (Volts)       3.23.03.2</p> <p>Payload Type         24</p> <p>Kero Wt. (Lb)         8.8</p> <p>Orifice                0.67</p> <p>Initial Pressure      190 PSI</p> <p>No. of Cycles        109</p> <p>Run Time              282</p> <p>Sec. per Cycle        2.58</p> |                     |      |                    |      |              |                     |      |                      |

TABLE 7  
TEST DATA

| Container No.  | Total Weight Pounds |                | Total Weight Grams |      | No. of Puffs     | Total On Time (sec) |         | Total Off Time (sec) |
|----------------|---------------------|----------------|--------------------|------|------------------|---------------------|---------|----------------------|
| 1              | 0.97                | 0.97           | 440                | 440  | 12               | 4.2                 | 4.2     | 34.1                 |
| 2              | 0.95                | 1.92           | 431                | 871  | 12               | 4.2                 | 8.4     | 68.2                 |
| 3              | 0.89                | 2.81           | 404                | 1275 | 12               | 4.2                 | 12.6    | 102.2                |
| 4              | 0.81                | 3.62           | 367                | 1642 | 12               | 4.2                 | 16.8    | 136.3                |
| 5              | 0.76                | 4.38           | 345                | 1987 | 12               | 4.2                 | 21.0    | 170.4                |
| 6              | 0.73                | 5.11           | 331                | 2318 | 12               | 4.2                 | 25.2    | 204.5                |
| 7              | 0.70                | 5.81           | 318                | 2635 | 12               | 4.2                 | 29.4    | 238.6                |
| 8              | 0.66                | 6.47           | 299                | 2935 | 12               | 4.2                 | 33.6    | 272.6                |
| 9              | 0.61                | 7.08           | 277                | 3211 | 12               | 4.2                 | 37.8    | 306.7                |
| 10             | 0.56                | 7.64           | 254                | 3466 | 12               | 4.2                 | 42.0    | 340.8                |
| 11             | 0.53                | 8.17           | 240                | 3706 | 12               | 4.2                 | 46.2    | 374.8                |
| 12             | 0.52                | 8.69           | 236                | 3942 | 12               | 4.2                 | 50.4    | 408.9                |
| 13             | 0.12                | 8.81           | 54                 | 3996 | 3                | 1.1                 | 51.5    | 417.4                |
| Valve Type     |                     | Toggle - 3 Cam |                    |      | Orifice          |                     | 0.67    |                      |
| On Time (Sec)  |                     | 0.35           |                    |      | Initial Pressure |                     | 190 PSI |                      |
| Off Time (Sec) |                     | 1.85           |                    |      | No. of Cycles    |                     | 147     |                      |
| ViVrVf (Volts) |                     | 3.23.03.1      |                    |      | Run Time         |                     | 420     |                      |
| Payload Type   |                     | 24             |                    |      | Sec. per Cycle   |                     | 2.84    |                      |
| Kero Wt. (Lb)  |                     | 8.8            |                    |      |                  |                     |         |                      |

TABLE 8  
TEST DATA

| Container No.  | Total Weight Pounds |                | Total Weight Grams |      | No. of Puffs     | Total On Time (sec) |         | Total Off Time (sec) |
|----------------|---------------------|----------------|--------------------|------|------------------|---------------------|---------|----------------------|
| 1              | 0.76                | 0.76           | 344                | 344  | 8                | 4.0                 | 4.0     | 21.2                 |
| 2              | 0.77                | 1.53           | 349                | 694  | 8                | 4.0                 | 8.0     | 42.4                 |
| 3              | 0.74                | 2.27           | 336                | 1030 | 8                | 4.0                 | 12.0    | 63.6                 |
| 4              | 0.70                | 2.97           | 318                | 1347 | 8                | 4.0                 | 16.0    | 84.8                 |
| 5              | 0.66                | 3.63           | 299                | 1647 | 8                | 4.0                 | 20.0    | 106.0                |
| 6              | 0.58                | 4.21           | 263                | 1910 | 8                | 4.0                 | 24.0    | 127.2                |
| 7              | 0.58                | 4.79           | 263                | 2173 | 8                | 4.0                 | 28.0    | 148.4                |
| 8              | 0.55                | 5.34           | 249                | 2422 | 8                | 4.0                 | 32.0    | 169.6                |
| 9              | 0.53                | 5.87           | 240                | 2663 | 8                | 4.0                 | 36.0    | 190.8                |
| 10             | 0.53                | 6.40           | 240                | 2903 | 8                | 4.0                 | 40.0    | 212.0                |
| 11             | 0.48                | 6.88           | 218                | 3121 | 8                | 4.0                 | 44.0    | 233.2                |
| 12             | 0.47                | 7.35           | 213                | 3334 | 8                | 4.0                 | 48.0    | 254.4                |
| 13             | 1.41                | 8.76           | 640                | 3973 | 23               | 11.5                | 59.5    | 315.3                |
| Valve Type     |                     | Toggle - 1 Cam |                    |      | Initial Pressure |                     | 190 PSI |                      |
| On Time (Sec)  |                     | 0.5            |                    |      | No. of Cycles    |                     | 119     |                      |
| Off Time (Sec) |                     | 1.7            |                    |      | Run Time         |                     | 316     |                      |
| VIVrVf (Volts) |                     | 3.53,03.2      |                    |      | Sec. per Cycle   |                     | 2.65    |                      |
| Payload Type   |                     | 24             |                    |      |                  |                     |         |                      |
| Kero Wt. (Lb)  |                     | 8.8            |                    |      |                  |                     |         |                      |
| Orifice        |                     | 0.67           |                    |      |                  |                     |         |                      |

TABLE 9  
TEST DATA

| Container No.    | Total Weight Pounds |                | Total Weight Grams |      | No. of Puffs   | Total On Time(sec) |      | Total Off Time (sec) |
|------------------|---------------------|----------------|--------------------|------|----------------|--------------------|------|----------------------|
| 1                | 1.08                | 1.08           | 490                | 490  | 8              | 4.0                | 4.0  | 21.4                 |
| 2                | 1.03                | 2.11           | 467                | 957  | 8              | 4.0                | 8.0  | 42.7                 |
| 3                | 0.92                | 3.03           | 417                | 1374 | 8              | 4.0                | 12.0 | 64.1                 |
| 4                | 0.88                | 3.91           | 399                | 1774 | 8              | 4.0                | 16.0 | 85.4                 |
| 5                | 0.83                | 4.74           | 376                | 2150 | 8              | 4.0                | 20.0 | 106.8                |
| 6                | 0.80                | 5.54           | 363                | 2513 | 8              | 4.0                | 24.0 | 128.2                |
| 7                | 0.78                | 6.32           | 354                | 2867 | 8              | 4.0                | 28.0 | 149.5                |
| 8                | 0.75                | 7.07           | 340                | 3207 | 8              | 4.0                | 32.0 | 170.8                |
| 9                | 0.72                | 7.79           | 327                | 3553 | 8              | 4.0                | 36.0 | 192.2                |
| 10               | 1.02                | 8.81           | 463                | 3996 | 12             | 6.0                | 42.0 | 244.2                |
| Valve Type       |                     | Toggle - 1 Cam |                    |      | No. of Cycles  |                    | 84   |                      |
| On Time (Sec)    |                     | 0.5            |                    |      | Run Time       |                    | 225  |                      |
| Off Time (Sec)   |                     | 1.7            |                    |      | Sec. per Cycle |                    | 2.67 |                      |
| ViVrVf (Volts)   |                     | 3.63.13.2      |                    |      |                |                    |      |                      |
| Payload Type     |                     | 24             |                    |      |                |                    |      |                      |
| Kero Wt. (Lb)    |                     | 8.8            |                    |      |                |                    |      |                      |
| Orifice          |                     | .089           |                    |      |                |                    |      |                      |
| Initial Pressure |                     | 190 PSI        |                    |      |                |                    |      |                      |

TABLE 1A  
TEST DATA

TOGGLE VALVE

| Power Supply | Vi  | Vr  | Vf  | No. of Cycles | Run Time (Sec.)              | Pf PSI | Sec/Cycle | Grams/Cycle (Average) |
|--------------|-----|-----|-----|---------------|------------------------------|--------|-----------|-----------------------|
| 2-PMI        | 3.6 | 3.3 | 3.6 | 23            | 60                           | 40     | 2.61      | 140                   |
|              | 3.6 | 3.2 | 3.4 | 15            | 37                           |        | 2.47      |                       |
|              | 3.4 | 3.2 | 3.4 | 23            | 60                           |        | 2.61      |                       |
| 3-PMI        | 5.6 | 4.8 | 5.3 | 37            | 60                           | 40     | 1.62      | 87.5                  |
|              | 5.3 | 4.8 | 5.2 | 24            | 37                           |        | 1.54      |                       |
|              | 5.3 | 4.7 | 5.2 | 37            | 60                           |        | 1.62      |                       |
| 4-PMI        | 7.2 | 6.3 | 6.8 | 52            | 60                           | 45     | 1.15      | 63.7                  |
|              | 7.2 | 6.3 | 6.8 | 33            | 37                           |        | 1.12      |                       |
|              | 7.2 | 6.3 | 6.7 | 52            | 60                           |        | 1.15      |                       |
| 5-PMI        | 8.8 | 7.8 | 8.5 | 66            | 60                           | 40     | .91       | 50.1                  |
|              | 8.6 | 7.8 | 8.5 | 42            | 37                           |        | .88       |                       |
|              | 8.6 | 7.8 | 8.5 | 65            | 60                           |        | .92       |                       |
| 2-PMI        | 3.4 | 3.0 | 3.2 |               | 300<br>22 in last 60 seconds |        | 2.73      |                       |
| 2-N57        | 2.6 | 2.6 | 2.6 |               | 300<br>17 in last 60 seconds |        | 3.53      |                       |

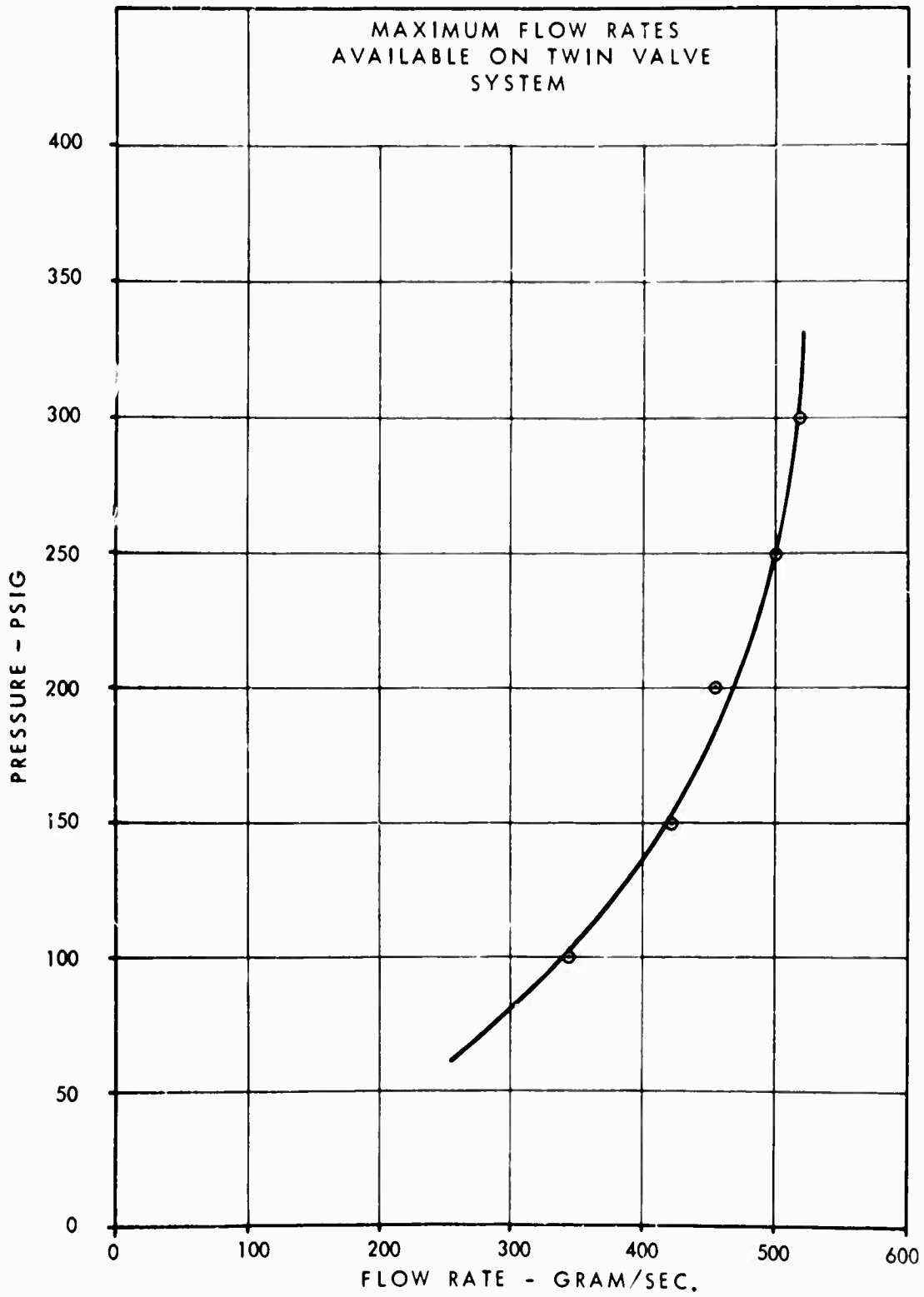

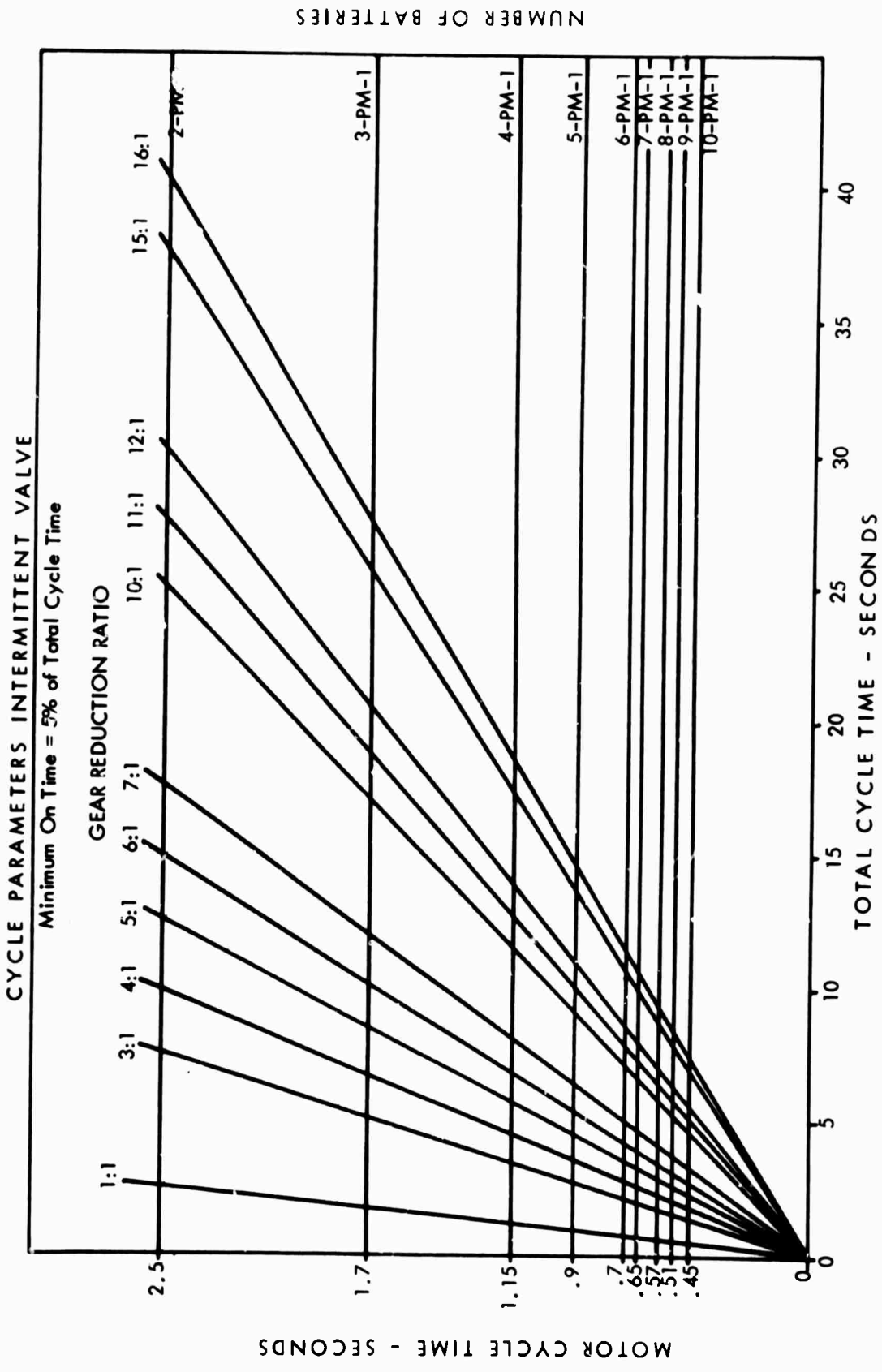

NUMBER OF BATTERIES

FIGURE 16

APPENDIX E

TANK DESIGN EQUATIONS



SPACE DATA CORPORATION

PHOENIX, ARIZONA

PREPARED BY EEA DATE \_\_\_\_\_PAGE 1

CHECKED BY \_\_\_\_\_ DATE \_\_\_\_\_

JOB \_\_\_\_\_

SUBJECT TANK DESIGNWALL THICKNESSASSUME: YIELD PRESSURE = TWICE WORKING PRESSURE

FACTOR OF SAFETY ON YIELD = 1.15

CYLINDER

$$S_T = \frac{P_w D_i}{2T}$$

$$S_Y = \left[ S_T^2 + \left( \frac{1}{2} S_T \right)^2 \right]^{1/2} = 1.12 S_T$$

$$S_Y = \frac{1.12 (F.S.) (2 P_w) D_i}{2T} =$$

$$S_Y = \frac{1.29 P_w D_i}{T}$$

$$T = \frac{1.29 P_w D_i}{S_Y}$$

$S_T$ : TANGENTIAL STRESS  
 $S_Y$ : YIELD STRESS  
 F.S.: FACTOR OF SAFETY  
 $P_w$ : WORKING PRESSURE  
 T: THICKNESS

1.12(1.15)



SPACE DATA CORPORATION

FORM NO. SD-1004A

PREPARED BY \_\_\_\_\_ DATE \_\_\_\_\_

PAGE 2

CHECKED BY \_\_\_\_\_ DATE \_\_\_\_\_

JOB \_\_\_\_\_

SUBJECT

ELLIPSOID (3:1)

$$S_{max} = \frac{D_i P_{max}}{2T} \left( 1 + .032 \left( \frac{a}{b} \right)^2 \right)$$

$$S_y = \frac{2(FS) D_i P_m}{2T} (1 + .032 (a))$$

$$S_y = \frac{1.47 D_i P_w}{T}$$

$$T = \frac{1.47 D_i P_w}{S_y}$$

a = SEMI MAJOR AXIS  
b = SEMI MINOR AXIS



SUBJECT

FLAT PLATE (FIXED EDGE)

## MAX STRESS @ EDGE

$$S_R = \frac{3W}{4\pi T^2}$$

$$M_{STL} = 4$$

$$M_{AL} = 3$$

$$S_T = \frac{3W}{4\pi MT^2}$$

$$W = \frac{PD^2\pi}{4}$$

$$S_R = M S_T$$

$$S_T = \frac{1}{16} \frac{P_w D_i^2}{T^2}$$

$$\text{FOR ALUMINUM } S_{T \text{ TOT}} = (S_R^2 + S_T^2)^{1/2} = (9S_T^2 + S_T^2)^{1/2} = 3.3 S_T$$

$$S_Y = 3.3(2)(1115) \left( \frac{1}{16} \frac{P_w D_i^2}{T^2} \right)$$

$$S_Y = .475 \frac{P_w D_i^2}{T^2}$$

$$T = \left( \frac{.475 P_w D_i^2}{S_Y} \right)^{1/2} \quad \text{ALUMINUM}$$

$$T = \left( \frac{.59 P_w D_i^2}{S_Y} \right)^{1/2} \quad \text{STEEL}$$

$$\frac{(165 + 215)^2}{(1750)^2}$$

4.1 ST

$$\frac{(4.1)(.475)}{3.3} = .59$$

APPENDIX F

BARIUM BURNER NOZZLE TESTS

(REFERENCE TM 193)

## RESULTS.

### 1.1 General.

Test information is summarized in Table 1 where tests are grouped according to general configurations tested, including (1) 2.4 Kg and (2) 6 Kg burners. Rupture disks were used to seal each burner until ignition. Rupture disks for all 1/2 inch diameter venting systems were designed to fail at 1530 psi, whereas the rupture disc for the small metering orifices (.080 to .125 in. dia.) were designed to fail at 300 psi. Single rupture discs were used in the 2.4 Kg burners and dual rupture discs were used in the 6 Kg burners.

### 1.2 Nozzles.

Nozzle systems tested included (1) steel nozzles, (2) graphite nozzles, (3) T-deflector nozzles, and (4) dual nozzles. Figures 1 through 6 illustrate these various nozzles and Table 1 relates specific nozzles to the applicable tests. In the original designs the nozzle assemblies were mated to the burner cap with pipe threads as shown in Figures 1A and 5. As a result of failure at this thread interface, the pipe thread was eliminated. Two new interface designs were tested, as shown in Figures 1B and 6, and found to be satisfactory.

The steel nozzles proved adequate for the 1/2 inch diameter port configuration shown in Figures 1 and 6 where final diameter after venting was approximately 0.6 inches.

The steel nozzle was ineffective in the smaller diameter size (illustrated in Figure 2A, Test 309-15, where the initial nozzle diameter was .080 inches and the final diameter was .60 inches.

Of the three graphite nozzle configurations tested, the first, illustrated in Figure 2B, was ineffective, Test 309-18, whereas the second and third configurations, illustrated in Figure 2C and D, showed severe erosion, but gave two seconds release time for an 800 gram charge.

Three T deflector nozzle tests were conducted. The major criteria was to T the exhaust gases by the simplest means possible. Weight was not a limiting criterion. During the first test, 309-16, the T nozzle burned thru at the pipe thread interface between the T and the canister lid. Thus, the test was rerun in Test 309-19 with the new interface design shown in Figure 4 using the same T nozzle as in 309-16.

During Test 309-19, the T burned through at the top as shown in Figure 3. Thus,

the T was redesigned and used in Test 309-25.

Test 309-25 was successful although the top inside of the T was eroded approximately 0.8 inches deep by the exhausting materials as illustrated in Figure 4.

## CONCLUSIONS

Tests indicated that release duration can be increased with high temperature high strength graphite nozzles.

Pipe thread interfaces between the rupture disc assembly and the canister have been eliminated.

The rupture disc steel 0.5 inch diameter nozzle was found to be satisfactory for the 2.4 Kg (309-24) and 6 Kg (319-39 and 333-34) for systems larger than 6Kg graphite inserts are recommended.

TABLE 1 - 2.4 Kg Burner (309) with Straight Nozzle

| Burner Tested                        | 309-14                           | 309-15             | 309-18             | 309-20             | 309-21             |
|--------------------------------------|----------------------------------|--------------------|--------------------|--------------------|--------------------|
| Purpose                              | Steel Nozzle and Burn Properties | Steel Nozzle       | Graphite Nozzle    | Graphite Nozzle    | Graphite Nozzle    |
| Date                                 | 2-15-67                          | 2-15-67            | 3-23-67            | 3-8-67             | 3-8-67             |
| Can Vol. (Cu. In)                    | 59                               | 59                 | 59                 | 20.3               | 20.3               |
| Net Chemical <sup>(1)</sup> Wt. (gm) | 2408                             | 2408               | 2400               | 800                | 800                |
| Gross Wt. (lb)                       | 16.4                             | 16.3               | 16.3               | -                  | -                  |
| Loading Pres. (psi)                  | 2130                             | 2130               | 2130               | 2130               | 2130               |
| Charge Density (gm/cc)               | 3                                | 3                  | 3                  | 3                  | 3                  |
| Additives (Element/gm)               | Sr/8                             | Sr/8               | None               | None               | None               |
| Void in Top of Can (In)              | 0.5                              | 0.5                | 0.5                | 0.25               | 0.25               |
| No. of Increments                    | 4                                | 4                  | 4                  | 2                  | 2                  |
| Nozzle - Design (ref.)               | Fig. 1A                          | Fig. 2A            | Fig. 2B            | Fig. 2D            | Fig. 2C            |
| Material                             | Stnls. stl                       | Stnls. stl         | Graphite           | Graphite           | Graphite           |
| Diameter (In)                        | 0.5                              | 0.08               | 0.08               | 0.125              | 0.125              |
| Rupture Disc Burst Pres. (psi)       | 1530                             | 300 <sup>(7)</sup> | 300 <sup>(7)</sup> | 300 <sup>(7)</sup> | 300 <sup>(7)</sup> |
| <b>Results</b>                       |                                  |                    |                    |                    |                    |
| Final Nozzle Dia. (in)               | 0.6                              | 0.6                | 0.75               | 0.26               | 0.30               |
| Burn Time <sup>(2)</sup> (ms)        | 8                                | -                  | -                  | -                  | -                  |
| Release Time (ms)                    | -(6)                             | 450                | 0                  | 0                  | 0                  |
| Max Burn Pres <sup>(3)</sup> (psi)   | 7150                             | 4300               | -                  | -                  | -                  |
| Chemical Vented (gm)                 | 2220                             | 2180               | -                  | -                  | -                  |
| Oscillograph Record (ref)            | Fig. 2                           | Fig. 3             | -                  | -                  | -                  |
| Remarks                              | (4) (5)                          |                    | (8)                |                    |                    |

\*Appendix I

TABLE I  
TEST INFORMATION (2.4 Kg Burner with T-Nozzle)

| Burner Tested                        | 309-16      | 309-19                      | 309-25      |
|--------------------------------------|-------------|-----------------------------|-------------|
| Purpose                              | T-Deflector | T-Defelctor                 | T-Deflector |
| Date                                 | 2-16-67     | 3-6-67                      | 3-7-67      |
| Can Vol. (Cu. In.)                   | 59 59       | 59                          | 59          |
| Net Chemical <sup>(1)</sup> Wt. (gm) | 2408        | 2400                        | 2400        |
| Gross Wt. (lb)                       | 16.2        | 16.4                        | 16.3        |
| Loading Pressure (psi)               | 2130        | 2130                        | 2130        |
| Charge Density (gm/cc)               | 3           | 3                           | 3           |
| Additives (Element/gm)               | Sr/8        | None                        | None        |
| Void in Top of Can (In.)             | 0.5         | 0.5                         | 0.5         |
| No. of Increments                    | 4           | 4                           | 4           |
| Nozzle - Design (Ref.)               | Fig. 3      | Figs. 3 & 4 <sup>(10)</sup> | Fig 4       |
| Material                             | 4130 Stl    | 4130 Stl                    | 4130 Stl    |
| Diameter (In.)                       | 0.5         | 0.5                         | 0.5         |
| Rupture Disc Burst Pres. (Psi)       | 1530        | 1530                        | 1530        |
| <b>Results</b>                       |             |                             |             |
| Final Nozzle Dia. (In)               | 0.6         | 0.6                         | 0.6         |
| Burn Time (ms)                       | 10          | -                           | -           |
| Release Time (ms)                    | 300         | -                           | -           |
| Max. Burn Pressure (psi)             | 5540        | -                           | -           |
| Chemical Vented (gm)                 | 2180        | -                           | -           |
| Oscillograph Record (Ref.)           | Fig. 4      | -                           | -           |
| Remarks                              | (9)         | (11)                        | (12)        |

TABLE 1 (Continued) 6 Kg Burner (319)

| Burner Tested                        | 319-1                       | 319-2       | 319-3                       |
|--------------------------------------|-----------------------------|-------------|-----------------------------|
| Purpose                              | Structure & Burn Properties | Dual Nozzle | Structure & Burn Properties |
| Date                                 | 2-16-67                     | 3-7-67      | 3-15-67                     |
| Can Vol. (Cu. In.)                   | 150                         | 20.3        | 150                         |
| Net Chemical <sup>(1)</sup> Wt. (gm) | 6020                        | 800         | 6000                        |
| Gross Wt. (Lb)                       | 41                          | -           | 37                          |
| Loading Pressure (psi)               | 2130                        | 2130        | 2130                        |
| Charge Density (gm/cc)               | 3                           | 3           | 3                           |
| Void in Top of Can (In.)             | 1.25                        | 0.25        | 1.00                        |
| No. of Increments                    | 6                           | 1           | 4                           |
| Nozzle - Design (Ref.)               | Fig 5                       | Fig 5       | Fig 6                       |
| Material                             | Steel                       | Steel       | Steel                       |
| Diameter (In.)                       | 0.5 ea                      | 0.5 ea      | 0.5 ea                      |
| Rupture Disc Burst Pres. (psi)       | 1530                        | 1530        | 1530                        |
| Results:                             |                             |             |                             |
| Final Nozzle Dia. (In.)              | 0.6                         | -           | 0.6                         |
| Burn Time (ms)                       | 65                          | -           | -                           |
| Release Time (ms)                    | 570                         | -           | 270                         |
| Max. Burn Pres (psi)                 | 1940                        | -           | 2000                        |
| Chemical Vented (gm)                 | 5400                        | -           | -                           |
| Oscillograph Record (Ref)            | Fig. 9                      | -           | Fig. 10                     |
| Remarks                              | (9) (13)                    | (14)        |                             |

**NOTES:**

- (1) 75% Ba/25% CuO by Weight.
- (2) Start of pressure rise to burnout of thermistor (Minco) mounted on bottom inside of can.
- (3) Ormond pressure transducer.
- (4) Pressure transducer line ruptured.
- (5) Leak at Minco Feed through.
- (6) Not recorded.
- (7) Orifice filled with grease and covered with paper masking tape.
- (8) Graphite completely burned out.
- (9) Burn through at 1/2 NPT.
- (10) Tee as in Figure 3 . Interfaced with burner as shown in Figure 4 .
- (11) Burn through at top of tee (Figure 3).
- (12) Eroded 0.8 inched deep at top of tee (Fig. 4).
- (13) One rupture disc did not rupture.
- (14) Both rupture disks blew out at ignition.
- (15) Containment time 20 seconds.

**TABLE 1 - TEST INFORMATION (continued)**

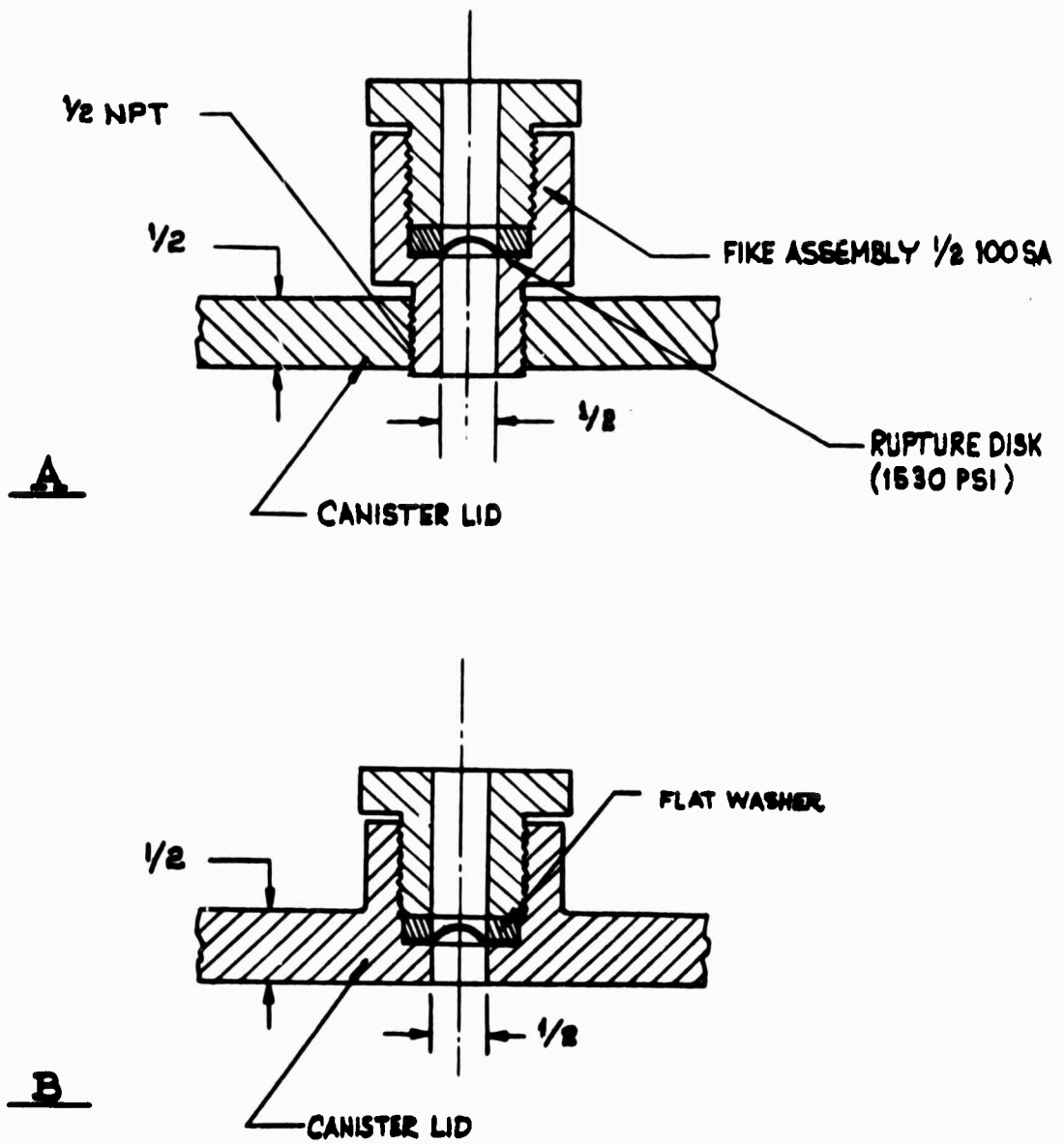

FIGURE 1  
 NOZZLE SKETCH - 0.5 INCH DIAMETER  
 (2.4 KG BURNER MOD. 309)

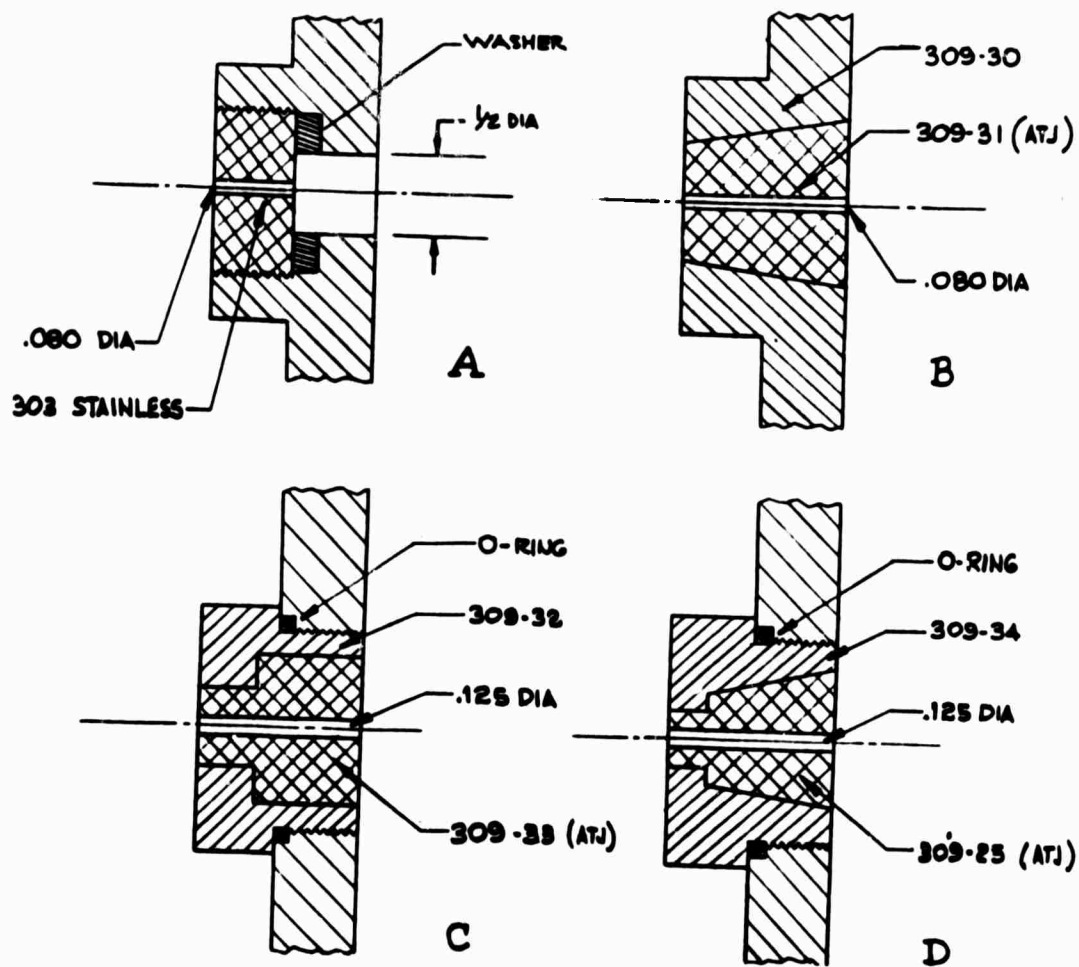

FIGURE 2

NOZZLE SKETCHES .080 and .125 IN DIA (2.4 KG BURNER)

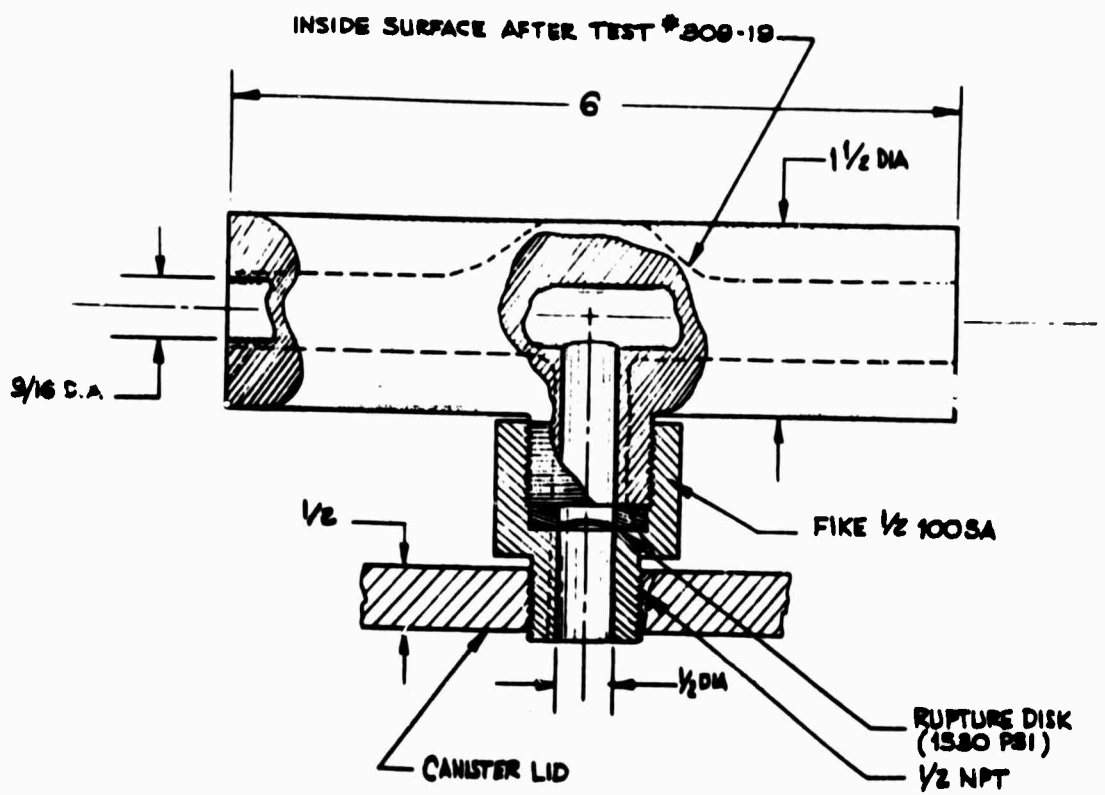

FIGURE 3

TEE NOZZLE (2.4 KG BURNER)

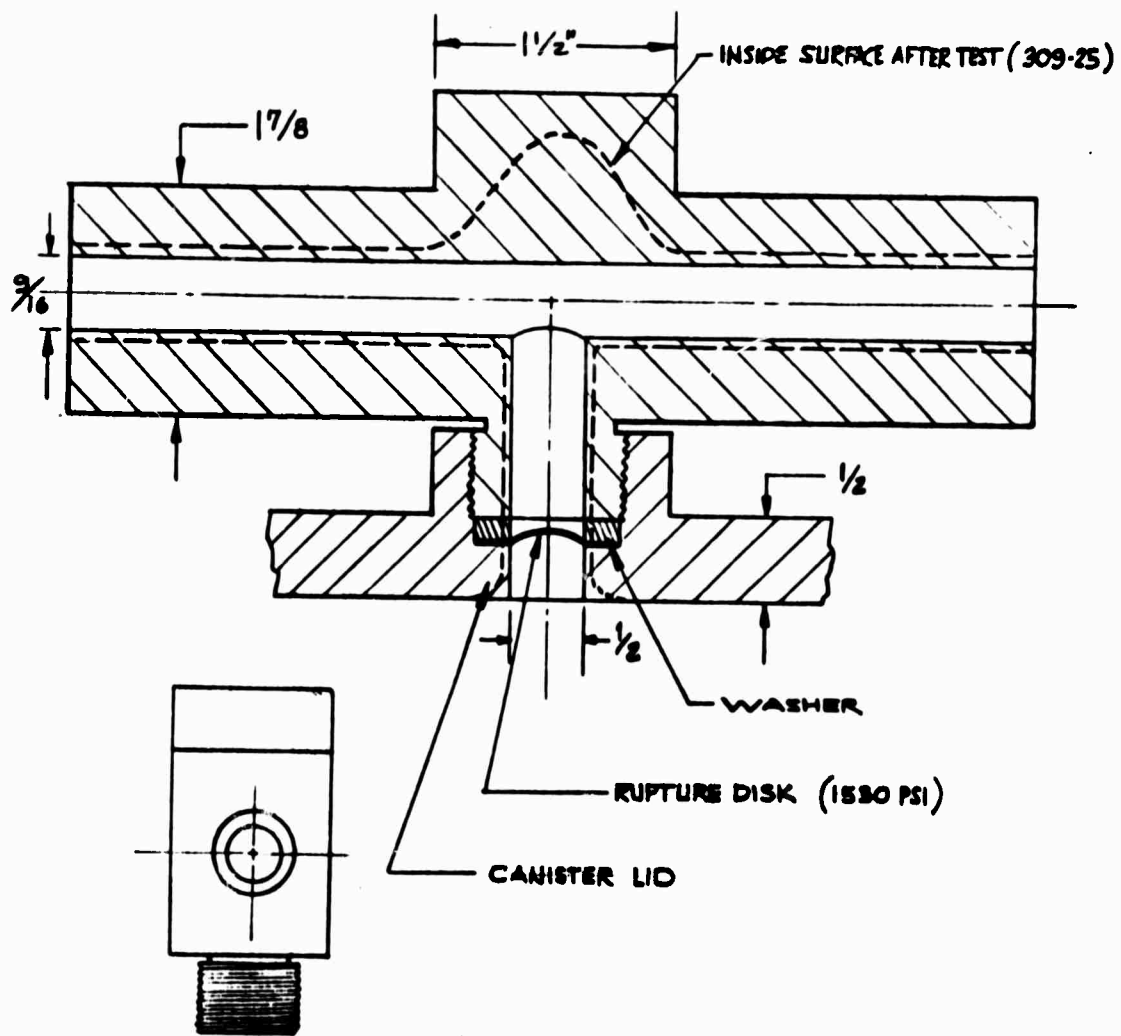

FIGURE 4

T-NOZZLE FINAL (2.4 KG BURNER)

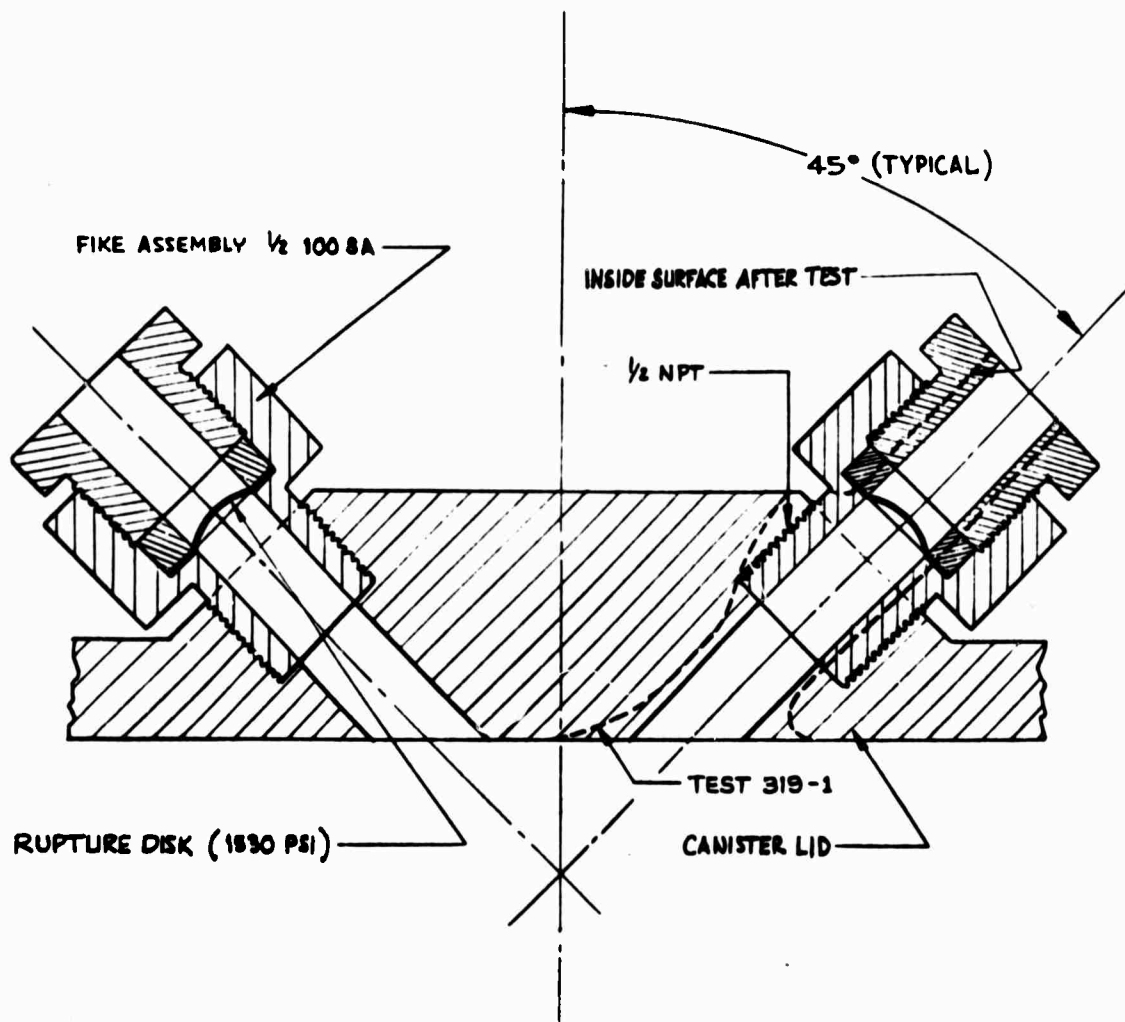

FIGURE 5  
 DUAL NOZZLE (6 KG BURNER)

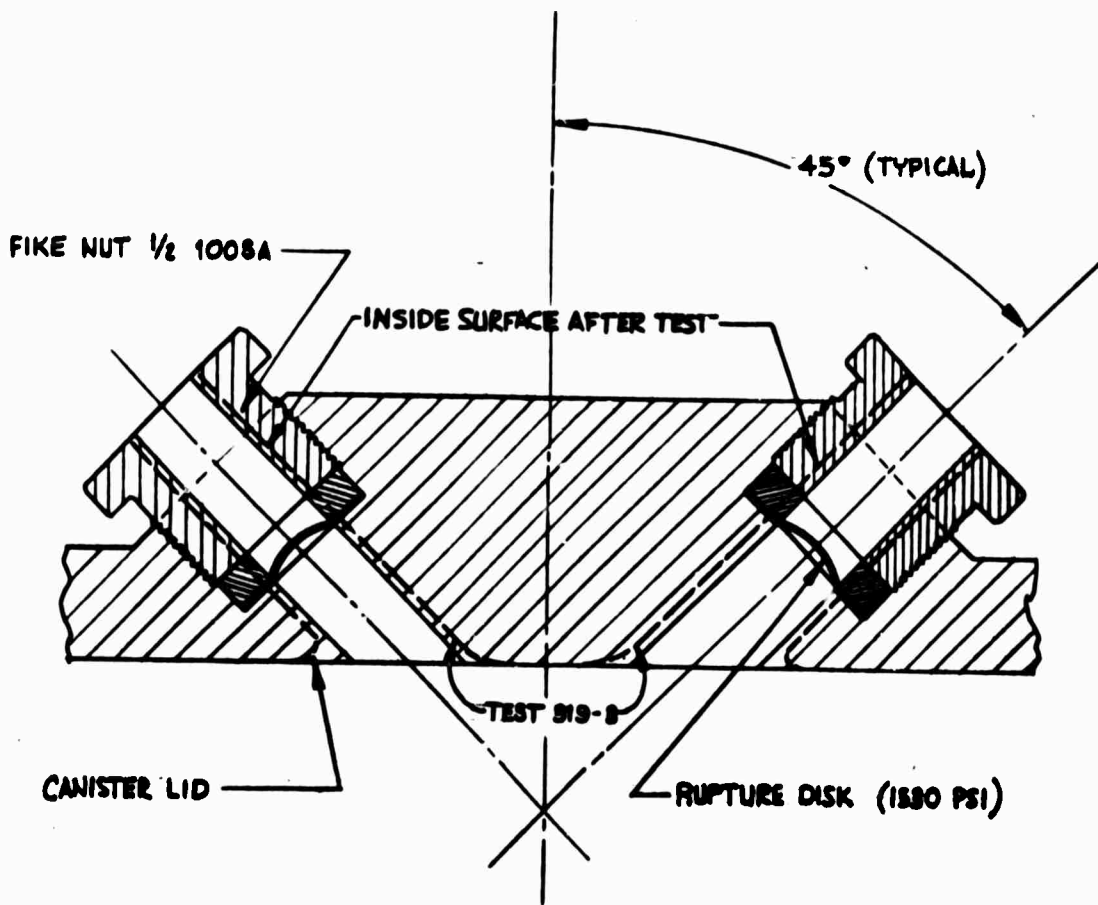

FIGURE 6  
DUAL NOZZLE FINAL 6 KG BURNER

APPENDIX G

BARIUM BURNER CALORIMETER TESTS

(Reference TM 255)

## INTRODUCTION

The information contained in this report documents the series of 5 Calorimeter tests conducted by Space Data during the month of August 1967.

The objective of this test series was to determine the output energy of two types of thermite material manufactured by SDC.

All tests were conducted utilizing sealed (non-ported) canisters of the Space Data Corporation Model 309 configuration.

## TEST DEVICES

The 5 devices tested were configured as follows:

| <u>S/N Device</u> | <u>Thermit Mix</u>                                  | <u>Thermite Loaded Weight</u> |
|-------------------|---|-------------------------------|
| 309-27            | Mix "A"<br>1800 Ba gms<br>600 CuO gms               | 2400 grams                    |
| 309-42            | Mix "E"<br>760 Ba gms<br>1770 CuO gms<br>210 Be gms | 2740 grams                    |
| 309-44            | Mix "A"<br>Same as Above                            | 2400 grams                    |
| 309-45            | Mix "E"<br>Same as Above                            | 2319 grams                    |
| 309-46            | Mix "E"<br>Same as Above                            | 2500 grams                    |

Each canister was loaded with a forming pressure of 2130 psi. Ignition of the thermite material was accomplished by the use of a single S-90 igniter squib mounted in the lid of each device.

The "E" mix canisters (-42, -45, -46) differed from the "A" mix canisters by an increase in canister wall thickness to approximately twice size. The internal volume of all the test devices were the same (59 in<sup>3</sup>).

## TEST SETUP

A hole was dug approximately three feet deep by two feet in diameter and lined internally with polyethylene sheet. The hole was then loaded with 200 pounds of water (90.0 Kg H<sub>2</sub>O). The test device was then suspended approximately two-thirds the total available depth of water. Temperature was recorded by use of mercury thermometers which were calibrated to read 1/10° C.

## TEST RESULTS

Test device 309-27 ("A" mix) was test fired in the calorimeter tank on August 2, 1967. The unit fired successfully and no leaks occurred. The data obtained appears in Table 1 and a plot of temperature vs time is shown in Figure 1.

### Results:

1. Temperature Rise =  $T_f - T_1 = 42^{\circ}\text{C} - 33^{\circ}\text{C} = 9^{\circ}\text{C}$

2. Specific Heats H<sub>2</sub>O =  $1 \frac{\text{cal}}{\text{gm}^{\circ}\text{C}}$  Iron =  $0.114 \frac{\text{cal}}{\text{gm}^{\circ}\text{C}}$

3. Total Energy (H)

Water  $H = (90.9)(9) = 818 \text{ K Cal}$

Steel (unit steel tare weight = 5.22K gm)

$$H = (5.22)(9)(0.114) = 5.35 \text{ K Cal}$$

$$\text{Total Energy} = 823.35 \text{ K Cal}$$

It must be noted that the water in the tank was not stirred or circulated during the time that the data was being recorded except for the last temperature reading. It became obvious that a true picture of temperature rise can only be obtained by circulation of the water prior to temperature readings.

Test device 309-42 ("E" mix) was loaded and test-fired in the calorimeter tank on August 8, 1967. The result was an explosion which completely destroyed the calorimeter tank. Examination of the canister which was found buried at the bottom of the hole clearly indicated that the lid of the canister was blown out.

Test device 309-44 ("A" mix) was loaded and test-fired successfully in a new calorimeter tank on August 9, 1967. The unit experienced a slight pressure leak. The



TABLE 1

CALORIMETER TEST NO. 1

Canister Type - Model 309 S/N 26

Thermite - "A" Mix

| <u>Time (Sec.)</u> | <u>Time (Min.)</u> | <u>Temperature (° C)</u> |
|--------------------|--------------------|--------------------------|
| 0                  | 0                  | 33.0                     |
| 50                 |                    | 32.0                     |
| 60                 | 1                  | 33.0                     |
| 70                 |                    | 35.0                     |
| 80                 |                    | 36.0                     |
| 90                 |                    | 36.0                     |
|                    | 5                  | 45.0                     |
|                    | 8                  | 42.0                     |

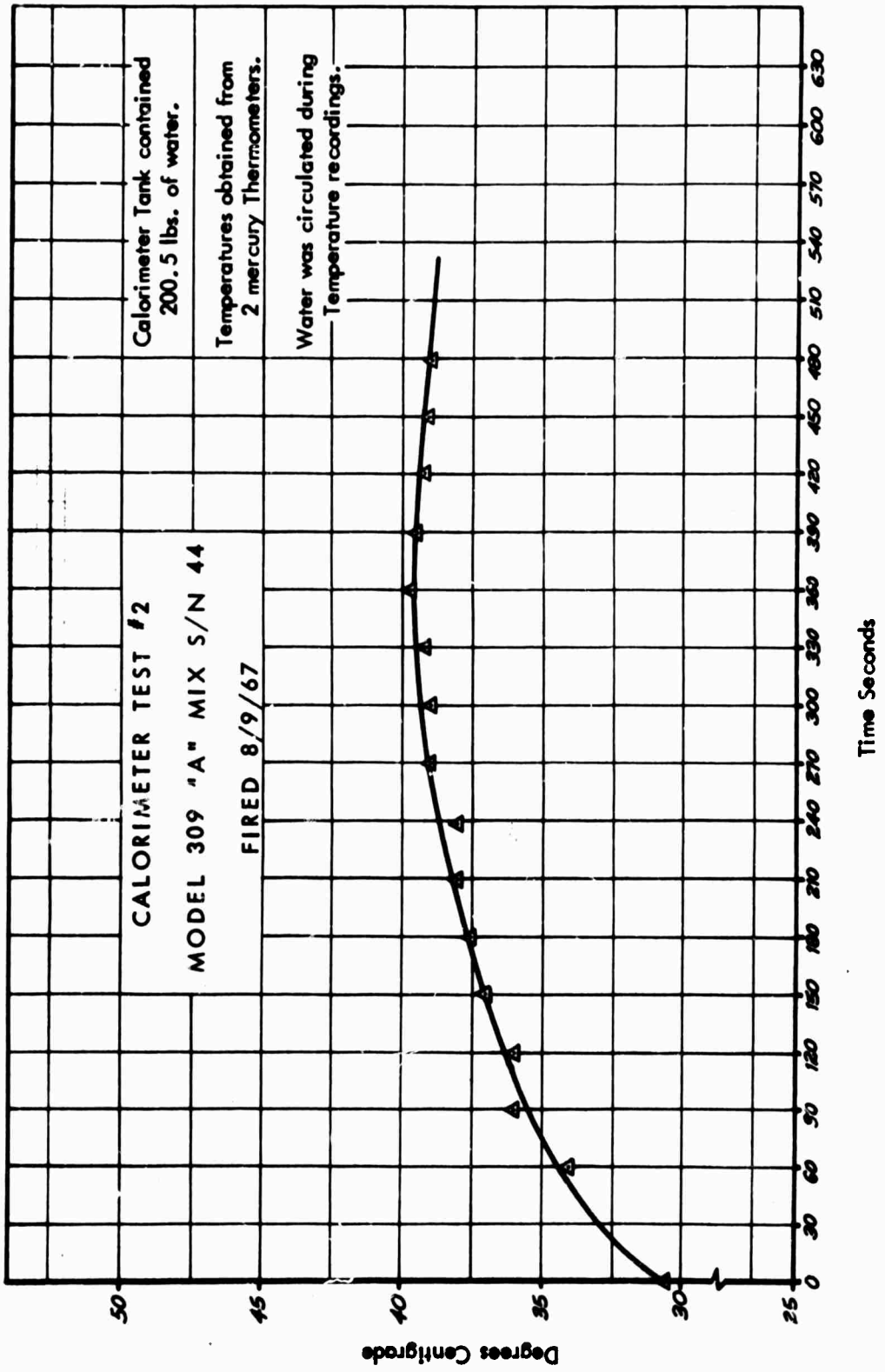

TABLE 2

## CALORIMETER TEST NO. 3

Canister Type - Model 309 S/N 44

Thermite - "A" Mix

| <u>Time (Sec.)</u> | <u>Time (Min.)</u> | <u>Temperature (° C)</u> |
|--------------------|--------------------|--------------------------|
| 0                  | 0                  | 30.5                     |
| 30                 |                    |                          |
| 60                 | 1                  | 34.0                     |
| 90                 |                    | 36.0                     |
| 120                | 2                  | 36.0                     |
| 150                |                    | 37.0                     |
| 180                | 3                  | 37.5                     |
| 210                |                    | 38.0                     |
| 240                | 4                  | 38.0                     |
| 270                |                    | 39.0                     |
| 300                | 5                  | 29.0                     |
| 330                |                    | 39.2                     |
| 360                | 6                  | 39.5                     |
| 390                |                    | 39.5                     |
| 420                | 7                  | 39.2                     |
| 450                |                    | 39.0                     |
| 480                | 8                  | 39.0                     |

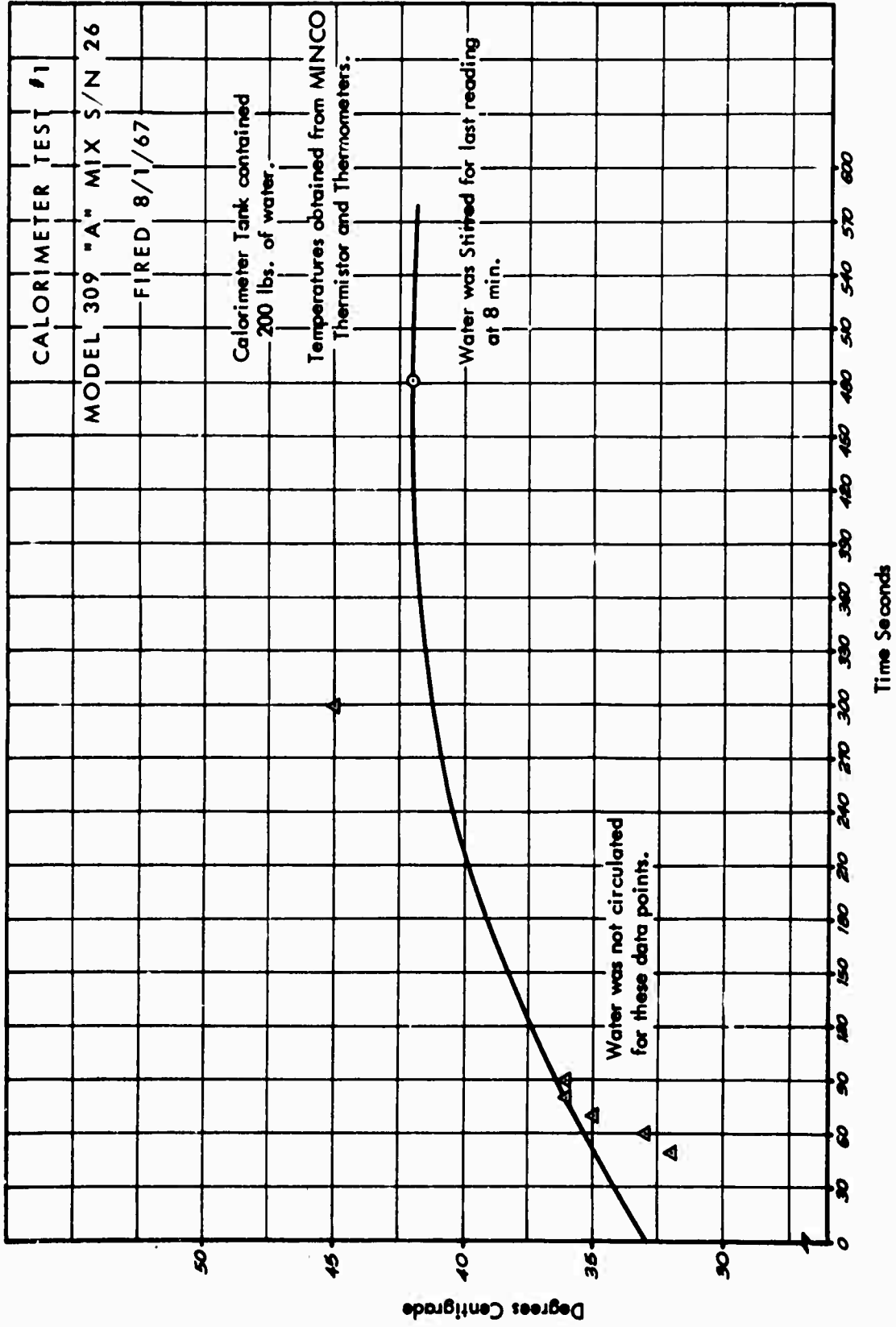

8 - G

A-1790

APPENDIX H

BARIUM BURNER TABULATED TEST RESULTS

| Model  | S/N | Date Fired | Prime Objective                          | Mix  | Chemical Wt. (gms)  | Loading Pressure | Vent <sup>(6)</sup> Type    | Burner Volume Cu In  | Max. Pres. (psi)    | Vent Time (ms) | Reference Appendix | REMARKS   |
|--------|-----|------------|--|------|---------------------|------------------|-----------------------------|----------------------|---------------------|----------------|--------------------|---|
| 309-24 | 1   | 11/30/66   | Pressure Structure                       | A    | 200                 | 2500             | Closed                      | 7.1 <sup>(15)</sup>  | 2000 <sup>(3)</sup> | -              |                    |   |
| 309-24 | 2   | 11/30/66   | Pressure Structure                       | A    | 200                 | 2500             | Closed                      | 5.3 <sup>(15)</sup>  | 2250 <sup>(3)</sup> | -              |                    |   |
| 309-24 | 3   | 11/30/66   | Pressure Structure                       | A    | 200                 | 2500             | Closed                      | 5.3 <sup>(15)</sup>  | 2500 <sup>(3)</sup> | -              |                    |   |
| 309-24 | 4   | 11/30/66   | Pressure Structure                       | A    | 200                 | 2130             | Closed                      | 10.6 <sup>(15)</sup> | 1000 <sup>(3)</sup> | -              |                    |   |
| 309-24 | 5   | 12/1/66    | Structural Pressure                      | As   | 1600 <sup>(4)</sup> | 2130             | Closed                      | 58.5                 | -                   | -              | -                  | Structure O.K.  |
| 309-24 | 6   | 12/2/66    | Pressure Structure                       | As-8 | 2408 <sup>(4)</sup> | 2130             | Steel Nozzle                | 58.5                 | 5700 (7)(12)        | 240            | -                  | Lid Yielded 0.125 at center. Max bottom outside temperature = 120°C (2) |
| 309-24 | 7   | 12/10/66   | Vacuum Chamber (Temple) Spectral Studies | As   | 2200                | 2130             | Nozzle                      | 58.5                 | -                   | -              | -                  | Structure O.K.  |
| 309-24 | 8   | 1/15/67    | Flight Test Eglin                        | As-8 | 2408                | 2130             | Steel Nozzle                | 58.5                 | -                   | -              | -                  | Vehicle Failure   |
| 309-24 | 9   | 1/15/67    | Flight Test Eglin                        | As-8 | 2408                | 2130             | Steel Nozzle                | 58.5                 | -                   | -              | -                  | Vehicle Failure   |
| 309-24 | 10  | 1/15/67    | Flight Test Eglin                        | As-8 | 2408                | 2130             | Steel Nozzle                | 58.5                 | -                   | -              | -                  | Vehicle Failure   |
| 309-24 | 11  | 1/16/67    | Flight Test Eglin                        | As-8 | 2408                | 2130             | Steel Nozzle                | 58.5                 | -                   | -              | -                  | No Release  |
| 309-24 | 12  | 1/16/67    | Flight Test Eglin                        | As-8 | 2408                | 2130             | Steel Nozzle                | 58.5                 | -                   | -              | -                  | Release = 156 Km Solar Horizon = 36 Km                                  |
| 309-24 | 13  | 1/16/67    | Flight Test Eglin                        | As-8 | 2408                | 2130             | Steel Nozzle                | 58.5                 | -                   | -              | -                  | Release = 194.1 Km Solar Horizon = 38 Km                                |
| 309-24 | 14  | 2/15/67    | Steel Nozzle                             | As   | 2408                | 2130             | Nozzle                      | 58.5                 | 7100 <sup>(7)</sup> | -              | F & I              | Final nozzle diameter = 0.6 inches<br>Chemical vented = 2220 grams      |
| 309-24 | 15  | 2/15/67    | Steel Nozzle <sup>(9)</sup>              | As   | 2408                | 2130             | Nozzle<br>0.080 Diameter    | 58.5                 | 4300 <sup>(7)</sup> | -              | F & I              | Final Nozzle diameter = 0.6 inches<br>Chemical vented = 2180 grams      |
| 309-24 | 16  | 2/16/67    | T-nozzle                                 | As   | 2408                | 2130             | T-nozzle                    | 58.5                 | 5540 <sup>(7)</sup> | -              | F & I              | Burn through at top of T-nozzle. Interface (1/2 rpt) to lid.            |
| 309-24 | 17  | 2/16/67    | Burn properties                          | As   | 2408                | 2130             | Closed                      | 58.5                 | 5250 <sup>(7)</sup> | -              | I                  | Containment Time - 11 seconds   |
| 309-24 | 18  | 3/23/67    | Graphite Nozzle (.08) <sup>(9)</sup>     | A    | 2400                | 2130             | Graphite Nozzle (0.080 dia) | 58.5                 | -                   | -              | F                  | Final Nozzle dia. - 0.75 inches<br>Graphite completely burned out       |

B-2057

| Model  | S/N | Date Fired | Prime Objective  | Mix   | Chemical Wt. (Grams) | Loading Pressure | Vent (A) Type                      | Burner Volume Cu. In. | Maximum Pressure (psi) | Vent Time (ms) | Reference Appendix | REMARKS   |
|--------|-----|------------|--|-------|----------------------|------------------|------------------------------------|-----------------------|------------------------|----------------|--------------------|---|
| 199-24 | 19  | 3/6/67     | T-nozzle   | A     | 2400                 | 2130             | T-nozzle                           | 58.5                  | -                      |                | F                  | Final nozzle diameter = 0.6 inches  |
|        | 20  | 3/8/67     | Graphite nozzle (9)  | A     | 800                  | 2130             | Graphite nozzle 0.125 diameter     | 20.3                  | -                      |                | F                  | Final nozzle diameter = 0.26 inches   |
|        | 21  | 3/8/67     | Graphite nozzle (9)  | A     | 800                  | 2130             | Graphite Nozzle 0.125 diameter     | 20.3                  | -                      |                | F                  | Final nozzle diameter = 0.30 inches   |
|        | 22  | 3/8/67     | Burn properties  | A     | 800                  | 2130             | Closed                             | 23.3                  | 2090                   |                | I                  | Containment Time = 60 seconds   |
|        | 23  | 3/15/67    | Burn properties  | A     | 1600                 | 2130             | Closed                             | 58.5                  | 4650(7)                |                | I                  | Containment Time = 20 seconds   |
|        | 24  | 3/15/67    | Burn properties  | A     | 1600                 | 2130             | Closed                             | 58.5                  | 2500                   |                | I                  | --  |
|        | 25  | 3/7/67     | T-deflector  | A     | 2400                 | 2130             | T-deflector                        | 58.5                  | -                      |                | F                  | Final nozzle diameter = 0.6 inches  |
|        | 26  | 8/8/67     | Spectral Test  | A8-8  | 2408                 | 2130             | Nozzle                             | 58.5                  | -                      |                | G                  | Misfire CRL instrumentation   |
|        | 27  | 8/1/67     | Calorimeter  | A8-8  | 2408                 | 2130             | Nozzle                             | 58.5                  | -                      |                | -                  | Energy = 823.4 K calories   |
|        | 28  | 4/19/67    | Flight Test Eglin  | An 24 | 2424                 | 2130             | T-deflector                        | 58.5                  | -                      |                | -                  | Release altitude = 160.6 Km<br>Solar Horizon = 36 Km  |
|        | 29  | 4/27/67    | Flight Test Eglin  | An 60 | 2460                 | 2130             | T-deflector                        | 58.5                  | -                      |                | -                  | Release Altitude = 211.7 Km<br>Solar Horizon = 132 Km   |
|        | 30  | 5/4/67     | Unbalance due to dual nozzle   | A     | 2400                 | 2130             | Dual nozzle (333-34 configuration) | 58.5                  | -                      |                | -                  | No noticeable unbalance (Figure 1)  |
|        | 31  | 5/4/67     | Determine effects on thrust balance with igniter mounted on bottom of burner | A     | 2400                 | 2130             | Dual nozzle (333-34 configuration) | 58.5                  | -                      |                | -                  | No noticeable unbalance (Figure 1)  |
|        | 32  | 5/12/67    | Pressure   | A     | 2400                 | 10,000           | Closed                             | 58.5                  | 3420                   |                | I                  | Ignition Delay = 112 ms, Time to maximum pressure = 916 ms  |
|        | 33  | 5/23/67    | Pressure   | B     | 2540                 | 2130             | Closed                             | 58.5                  | 2660                   |                | I                  | Ignition Delay = 314 ms, Time to maximum pressure = 1060 ms   |
|        | 34  | 5/26/67    | Pressure   | C     | 2470                 | 2130             | Closed                             | 58.5                  | 2620                   |                | I                  | Ignition Delay = 328 ms, Time to maximum pressure = 823 ms  |
|        | 35  | 5/26/67    | Pressure, Flame Temperature  | A     | 2400                 | 2130             | Closed                             | 58.5                  | 1920                   |                | I                  | Ignition Delay = 438 ms, Time to maximum pressure = 527 ms. First temperature indication, bottom of burner = 732 ms (2) |

B-2038

| Model  | S/N     | Date Fired | Prime Objective             | Mix | Chemical Wt. (grams) | Loading Pressure | Vent Type     | Burner Volume Cu. In. | Maximum Pressure (psi) | Vent Time (ms) | Reference Appendix   | REMARKS  |  |
|--------|---------|------------|-----------------------------|-----|----------------------|------------------|---------------|-----------------------|------------------------|----------------|--|--|--|
| 309-24 | 36      | 5/26/67    | Pressure, Flame Temperature | D   | 3110                 | 2130             | Closed        | 58.5                  | -                      | -              | -  | No ignition, numerous attempts   |  |
|        | 37      | 5/26/67    | Pressure, Flame Temperature | E   | 2740                 | 2130             | Closed        | 58.5                  | 3290                   | -              | I  | Ignition Delay = 136 ms. Time to maximum pressure = 262 ms. No temperature data. Burner started to leak at 1.4 seconds then ruptured.  |  |
|        | 38      | 5/26/67    | Pressure, Flame Temperature | F   | 2490                 | 2130             | Closed        | 58.5                  | 2150                   | -              | I  | Ignition Delay = 242 ms. Time to maximum pressure = 548 ms. Lid ruptured at 1.4 seconds. No temperature data.  |  |
|        | 39      | 7/3/67     | Pressure, Flame Temperature | A   | 2400                 | 2130             | Closed        | 58.5                  | 2330                   | -              | I  | Ignition Delay = 81 ms. Time to maximum pressure = 46 ms. Maximum thermocouple temperature, 4500°F. Initial temperature rise = 90 ms from firing pulse, thermocouple melted. (8) |  |
| 309-24 | 40      | 8/8/67     | Spectral Test               | A   | 2400                 | 2130             | Single Nozzle | 58.5                  | -                      | -              | -  | AFCL Instrumentation   |  |
|        | 41      | 8/8/67     | Spectral Test               | E   | 2400                 | 2130             | Single Nozzle | 58.5                  | -                      | -              | -  | AFCL Instrumentation   |  |
|        | 42      | 8/8/67     | Calorimeter Test            | E   | 2640                 | 2130             | Closed        | 58.5                  | -                      | -              | G  | Tank Failed - No Test  |  |
|        | 43      | 8/8/67     | Calorimeter Test            | E   | 2540                 | 2130             | Closed        | 58.5                  | -                      | -              | G  | Tank Failed - No Test  |  |
|        | 44      | 8/9/67     | Calorimeter Test            | A   | 2400                 | 2130             | Closed        | 58.5                  | -                      | -              | G  | Energy = 823 K Calories  |  |
|        | 45      | 8/18/67    | Calorimeter Test            | E   | 2319                 | 2130             | Closed        | 58.5                  | -                      | -              | G  | Heavy wall tank (P <sub>t</sub> = 24,000 psi). Bottom lid failed - no test.  |  |
|        | 46      | 8/29/67    | Calorimeter Test            | E   | 2507                 | 2130             | Closed        | 58.5                  | -                      | -              | G  | Heavy wall burner - thread failed - no test.   |  |
|        | 47      | 2/15/68    | Pressure Pressure Decay     | A   | 2400                 | 2130             | Closed        | 58.5                  | 2000                   | -              | -  | -  | Time to maximum pressure = 82 ms<br>Pressure decay factor = 180 psi/second |
|        | 48      | 2/15/68    | Pressure                    | A   | 2400                 | 10,000           | Closed        | 58.5                  | 1800                   | -              | I  | Time to maximum pressure = 94 ms<br>Pressure Decay Factor = 200 psi/second   |  |
|        | 49      | 2/16/67    | Pressure                    | G   | 260                  | 2130             | Closed        | 58.5                  | 780                    | -              | I  | Time to maximum pressure = 170 ms<br>Pressure Decay Factor = 150 psi/second<br>Some percent void volume as 333-14  |  |
| 50     | 2/16/68 | Pressure   | G                           | 260 | 2130                 | Closed           | 58.5          | 860                   | -                      | I              | Time to maximum pressure = 150 ms<br>Pressure Decay Factor 200 psi/second<br>Some percent void volume as 309-49. |  |  |
| 51     | 2/16/68 | Pressure   | G                           | 130 | 2130                 | Closed           | 58.5          | 460                   | -                      | I              | Time to maximum pressure = 175 ms<br>Pressure Decay Factor = 120 psi/second<br>Mix Weight = 0.5 x 309 - 49       |  |  |
| 52     | 2/16/68 | Pressure   | G                           | 620 | 2130                 | Closed           | 58.5          | 1420                  | -                      | I              | Time to maximum pressure = 182 ms<br>Pressure Decay Factor = 270 psi/second<br>Mix weight = 2 x 309 - 49         |  |  |

| Model  | S/N | Date Fired | Prime Objective           | Mix   | Chemical Wt. (Gram) | Loading Pressure | Vent Type       | Burner Volume Cu. In. | Maximum Pressure (psi) | Vent Time (ms) | Reference Appendix | REMARKS  |
|--------|-----|------------|---------------------------|-------|---------------------|------------------|-----------------|-----------------------|------------------------|----------------|--------------------|--|
| 319-3P | 1   | 2/16/67    | Structure Burn properties | As-20 | 6020                | 2130             | Dual Nozzle     | 150                   | 1940                   | 570            | F & I              | Burn through at 0.5 NPT at nozzle (1-). This rupture disc did not rupture - use 400 psi model. Chemical vented = 5400 gm |
|        | 2   | 3/7/67     | Dual Nozzle               | A     | 800                 | 2130             | Dual Nozzle(16) | 20.3(15)              | -                      | -              | F                  | Both rupture discs failed simultaneously at ignition.  |
|        | 3   | 3/15/67    | Thrust                    | A     | 6000                | 2130             | Dual Nozzle(16) | 150                   | 2000                   | -              | F & I              | Ignition delay = 780 ms. Final nozzle diameter = 0.6 inches. Thrust = 3200 lbs.  |
|        | 4   | 3/15/67    | Burn properties           | A     | 6000                | 2130             | Closed          | 150                   | 2000                   | -              | F & I              | Ignition delay = 780 ms.   |
|        | 5   | 4/19/67    | Flight Test Eglin         | An-60 | 6060                | 2130             | Dual Nozzle(16) | 150                   | -                      | -              | -                  | Release Altitude = 118.2 Km<br>Solar Horizon = 35 Km   |
|        | 6   | 4/27/67    | Flight Test Eglin         | An-60 | 6060                | 2130             | Dual Nozzle(16) | 150                   | -                      | -              | -                  | Release Altitude = 150 Km<br>Solar Horizon = 128 Km  |
|        | 7   | 4/19/67    | Flight Test Eglin         | As-20 | 6020                | 2130             | Dual Nozzle(16) | 150                   | -                      | -              | -                  | Release Altitude = 196.4 Km<br>Solar Horizon = 370 Km  |
|        | 8   | 8/8/67     | Spectral Test             | As-20 | 6020                | 2130             | Dual Nozzle(16) | 150                   | -                      | -              | -                  | CRL Instrumentation  |
|        | 9   | 4/27/67    | Flight Test Eglin         | An-60 | 6000                | 2130             | Dual Nozzle(16) | 150                   | -                      | -              | -                  | No Release   |

B-2060

| Model  | S/N | Date Fired | Prime Objective   | Mix | Chemical Wt. (Grams) | Loading Pressure | Pressure Vent Type | Burner Volume Cu. In. | Maximum Pressure (psi) | Vent Time (ms) | Reference Appendix | REMARKS  |
|--------|-----|------------|---|-----|----------------------|------------------|--------------------|-----------------------|------------------------|----------------|--------------------|--|
| 333-34 | 1   | 5/8/67     | Structure Unbalance Test  | A   | 6000                 | 2130             | Dual Nozzle        | 130                   | -                      | -              | -                  | No noticeable unbalance (Figure 1).  |
|        | 2   | 6/12/67    | Pressure Nozzle Unbalance Thrust                                      | A   | 6000                 | 2130             | Dual Nozzle        | 130                   | 2040                   | 450            | I                  | Ignition Delay = 25 ms, Time to maximum pressure = 40 ms, no noticeable unbalance.   |
| 333-35 | 3   | 7/11/67    | Structure, Nozzle, Flame Temp, Pressure & Burn Time, Unbalance Thrust | A   | 13,600               | 2130             | Dual Nozzle        | 340                   | 1320                   | -              | I                  | Ignition Delay = 17 ms, Time to maximum pressure = 115 ms, maximum temperature reading = 5400°F (8) at 0 ms. No noticeable unbalance thrust.   |
| 333-34 | 4   | 7/5/67     | Pressure, Flame Temperature, Burn time, Rupture disc failure.         | A   | 6000                 | 2130             | Dual Nozzle        | 130                   | 1630                   | 650            | I                  | Ignition Delay = 18 ms, time to maximum pressure = 19 ms, no burn time or rupture disc failure time, thermocouple melted, (6000°F), Figure 2.  |
| 333-34 | 5   | 7/11/67    | Structure nozzle Flame Temp. Burn Time Pressure                       | E   | 6855                 | 2130             | Dual nozzle        | 130                   | 4300                   | -              | I                  | Ignition Delay = 13 ms, time to maximum pressure = 36 ms, thermocouple in top, pressure transducer in bottom. Maximum temperature 60 mv (6000°F), leveled at 40 mv (4500°F), one nozzle eroded from burner causing large thrust unbalance. |
| 333-34 | 6   | 10/3/67    | Flight-Wallops  | A   | 6000                 | 2130             | Dual Nozzle        | 130                   | -                      | -              | -                  | Ursula, Release altitude = 122 Km  |
|        | 7   | 10/3/67    | Flight-Wallops  | A   | 6000                 | 2130             | Dual Nozzle        | 130                   | -                      | -              | -                  | Ursula, Release Altitude = 186 Km  |
|        | 8   | 10/4/67    | Flight-Wallops  | A   | 6000                 | 2130             | Dual Nozzle        | 130                   | -                      | -              | -                  | Vera, Release Altitude = 102 Km  |
|        | 9   | 10/4/67    | Flight-Wallops  | A   | 6000                 | 2130             | Dual Nozzle        | 130                   | -                      | -              | -                  | Vera, Release Altitude = 187 Km  |
|        | 10  |            | Spare   | A   | 6000                 | 2130             | Dual Nozzle        | 130                   | -                      | -              | -                  | Storage at Eglin   |
|        | 11  | 10/3/67    | Flight-Wallops  | E   | 6855                 | 2130             | Dual Nozzle        | 130                   | -                      | -              | -                  | Ursula, Release Altitude = 226 Km  |
|        | 12  | 10/3/67    | Flight-Wallops  | E   | 6855                 | 2130             | Dual Nozzle        | 130                   | -                      | -              | -                  | Vera, Release Altitude = 226 Km  |
| 333-34 | 13  | 8/8/67     | Spectral Test   | A   | 6000                 | 2130             | Dual Nozzle        | 130                   | -                      | -              | -                  | AFCOL Instrumentation  |
| 333-35 | 14  | 2/15/67    | Pressure  | A   | 1774                 | 2130             | Closed             | 340                   | 780                    | -              | -                  | Time to maximum pressure = 275 ms, Pressure decay factor = 60 psi/second, Same percent void as planned for 363-33 burner.  |

9-2861

| Model    | S/N | Date Fired | Prime Objectives   | Mix | Chemical Wt. Grams | Burner Vol. Cu. In. | Configuration               | Results   | Action   |
|----------|-----|------------|--|-----|--------------------|---------------------|-----------------------------|---|--|
| 363-33P  | 1   | 3/28/67    | (1) Ignition Events<br>(2) Pressure switch function<br>(3) Max Pressure<br>(4) Lid Separation device | A   | 1830               | 288.5               | Heavy, Short 363 Burner     | (1) Delay detonator blew out of holder<br>(2) Allowing hot gas to burn shaped charge<br>(3) Burn through of tank cutting line<br><br>(1) Lid Separates at 300 ms  | Redesign Detonator holder  |
| 363-33P  | 2   | 4/2/68     | (1) Ignition Events<br>(2) Delay Detonator<br>(3) Detonator Holder<br>(4) Shaped Charge              | G   | 355                | 39.0                | Heavy, Short 363-33 Burner  |   |  |
| 363-33P  | 3   | 4/3/68     | Same as 363-33P-2  | G   | 355                | 39                  | Heavy, Short 363-33 Burner  | (1) Time to Max pressure = 131 ms<br>(2) Max Pressure = 1620 psi<br>(3) Lid Separation at 300 ms<br>(4) Pressure switch closed at 300 psi                         |  |
| 363-33P  | 4   | 4/4/68     | Same as 363-33P-2 Except 250 ms delay detonator used   | G   | 355                | 39                  | Heavy, Short 363-33 Burner  | (1) Time to Max pressure = 130 ms<br>(2) Max pressure = 1570 psi<br>(3) Lid Separation at 260 ms  |  |
| 363-33P  | 5   | 4/4/68     | Same as 363-33P-2 Except 200 ms Delay Detonator used   | G   | 355                | 39                  | Heavy, Short Burner, 363-33 | (1) Time to Max Pressure = 190 ms<br>(2) Max Pressure = 1550 psi<br>(3) Lid Separation at 190 ms  |  |
| 363-33P  | 6   | 4/4/68     | Pressure with void filled to void volume ration = 363-33 flight                                      | G   | 324                | 58.5                | 309-24                      | Max pressure = 875 psi  |  |
| 363-33P  | 7   | 4/4/68     | Ignition Events, Lid Separation release  | G   | 1830               | 322                 | Short, 363-33               | (1) Pressure switch closed at 300 psi<br>(2) Time to max pressure = 50 ms<br>(3) Maximum pressure = 875 psi for 100 ms<br>(4) Lid Separation                      |  |
| 363-33P  | 8   | 4/24/68    | Complete System function, 200 ms   | H   | 5450               | 1282                | Full Scale 230 ms delay     | (1) Clamp longitudinal pipe support bent<br>(2) Punctured hole in tank<br>(3) Silicann O-ring extruded from groove in lid allowing hot gas leakage burning O-ring | Redesigned barium clamp, reverted to BUNA N O-ring used originally |
| 363-33P  | 9   | 5/3/68     | Complete System Function rerun   | H   | 2775               | 641                 | Half scale 200 ms Delay     | (1) Pressure switch closed at 300 psi<br>(2) Lid Separation at 195 ms<br>(3) Max Pressure = 875 psi for 90 ms   |  |
| 363-33   | 10  | Flight     | Flight-Puerto Rico   | H   | 540                | 1282                |                             | Release 3 seconds late<br>Release Altitude 6.7° from Trinidad   |  |
| 351-44-1 | 1   | Flight     | Flight-Puerto Rico   | H   | 2180               | 3843                |                             | Release Altitude 2.6° from Trinidad<br>Release not visually observed  |  |

B-2062

NOTES:

1. Pressure determined with Ormond (Model GP-46F-10,000) pressure transducer and recorded on an oscillograph (Honeywell Model 906C).
2. Burner outside temperature monitored with a resistance thermistor Minco (Model 1064B).
3. Pressure determined with Bordon pressure gauge.
4. Press-loaded in four increments.
5. Indicates Appendix Number.
6. All Nozzles 0.5-inch diameter steel with 1500 psi rupture disc unless otherwise noted. Model 309-24, single nozzle model 319, 333 dual nozzles.
7. High pressure attributed to the presence of residual kerosene and/or benzene from preparation procedures.
8. Thermocouple Nanmac model B Tungsten-/Tungsten 26% Rhenium.
9. Attempted to extend vent time by reducing nozzle area.
10. Single igniter mounted in top of burner P/N-1 through -30.
11. Igniters (two) mounted in bottom of burner P/N -31 through 52.
12. Estimated from  $PV = WRT$ , and from tests 309-24 S/N 1 through 5.
13. Calculated pressure at which failure would occur.
14. Redesigned, eliminating NPT thread.
15. Burner partially filled with inert material.
16. Rupture Disc = 400 psi.

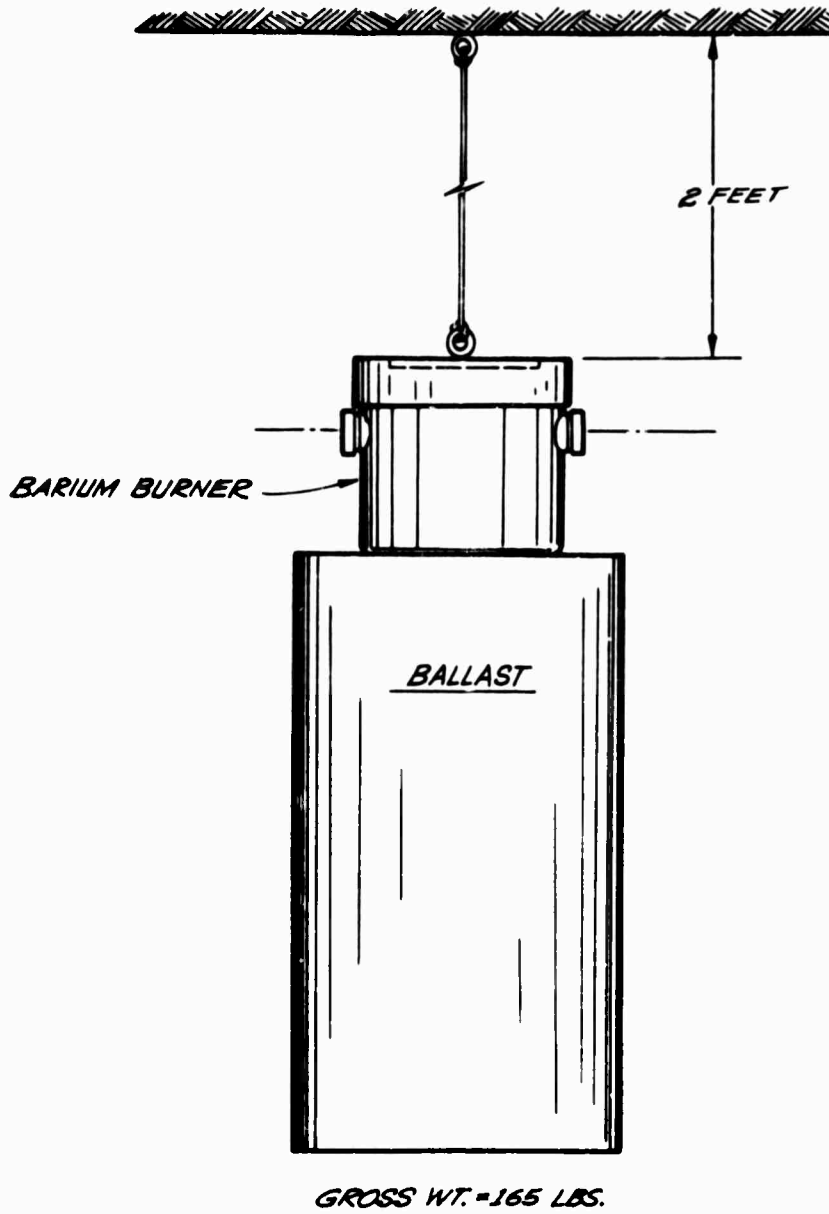

FIGURE 1  
309-24-30 and 31 TEST SET UP

H-9

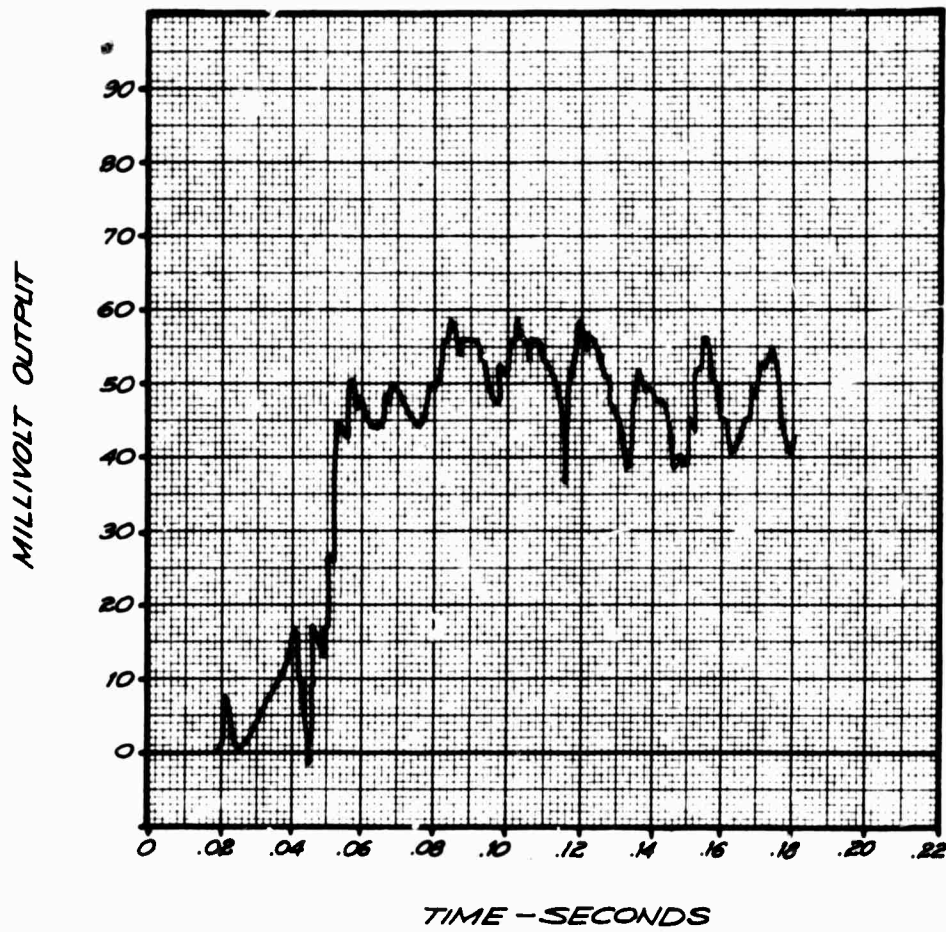

FIGURE 2  
TEST 333-34-4

H-10

**BLANK PAGE**

APPENDIX I

BARIUM BURNER PRESSURE TRACES

(REFERENCE TM 193)

## TABLE OF CONTENTS

| <u>FIGURE NO.</u> | <u>BURNER NO.</u> |
|-------------------|-------------------|
| 1                 | 309-24-15         |
| 2                 | 309-24-16         |
| 3                 | 309-24-17         |
| 4                 | 309-24-22         |
| 5                 | 309-24-23         |
| 6                 | 309-24-24         |
| 7                 | 309-24-32         |
| 8                 | 309-24-33         |
| 9                 | 309-24-34         |
| 10                | 309-24-35         |
| 11                | 309-24-37         |
| 12                | 309-24-38         |
| 13                | 309-24-39         |
| 14                | 309-24-48         |
| 15                | 309-24-49         |
| 16                | 309-24-50         |
| 17                | 309-24-51         |
| 18                | 309-24-52         |
| 19                | 319-39-1          |
| 20                | 319-39-3          |
| 21                | 319-39-4          |
| 22                | 333-34-2          |
| 23                | 333-35-3          |
| 24                | 333-34-4          |
| 25                | 333-34-5          |

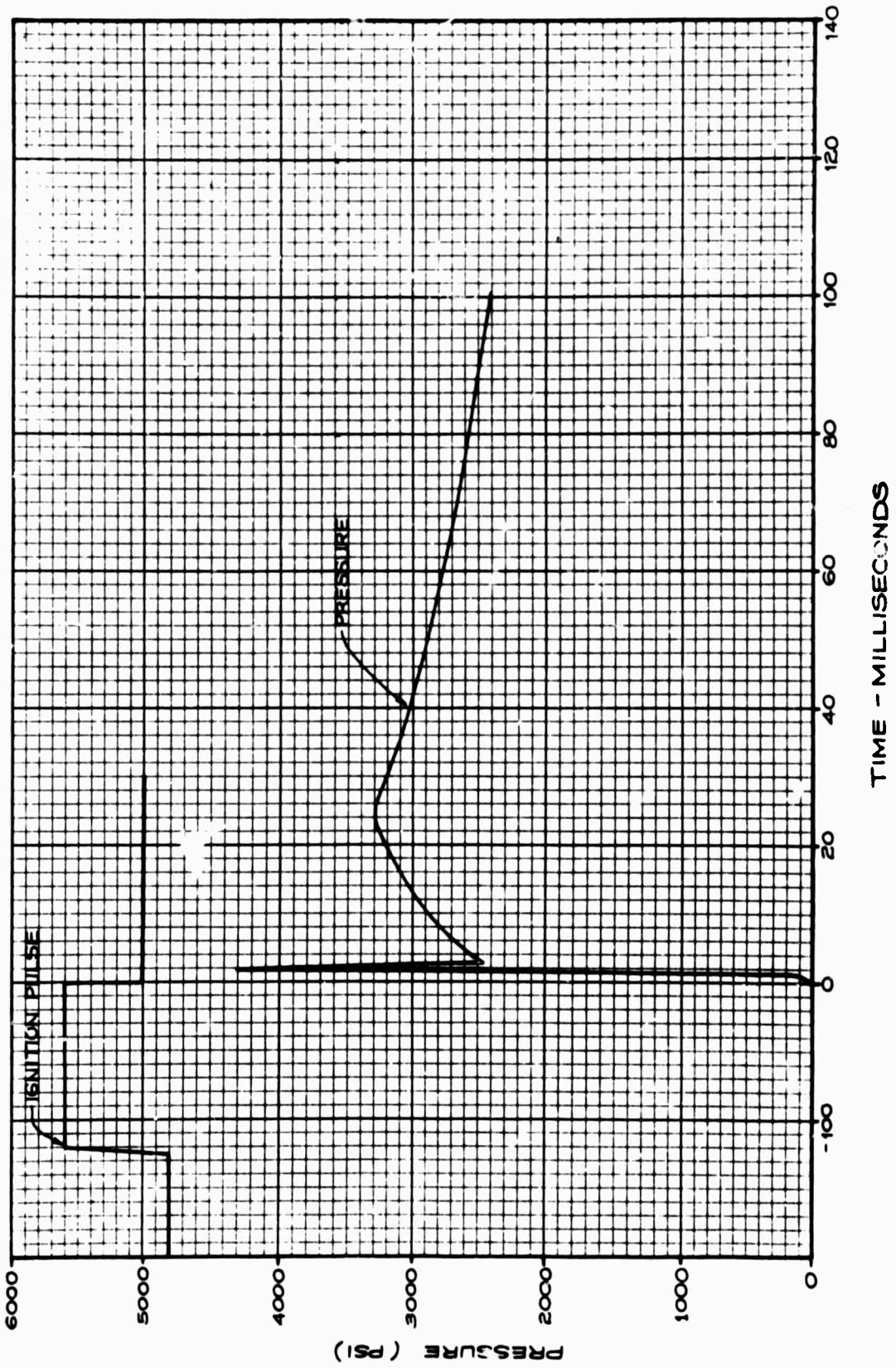

FIGURE 1 309-24-15

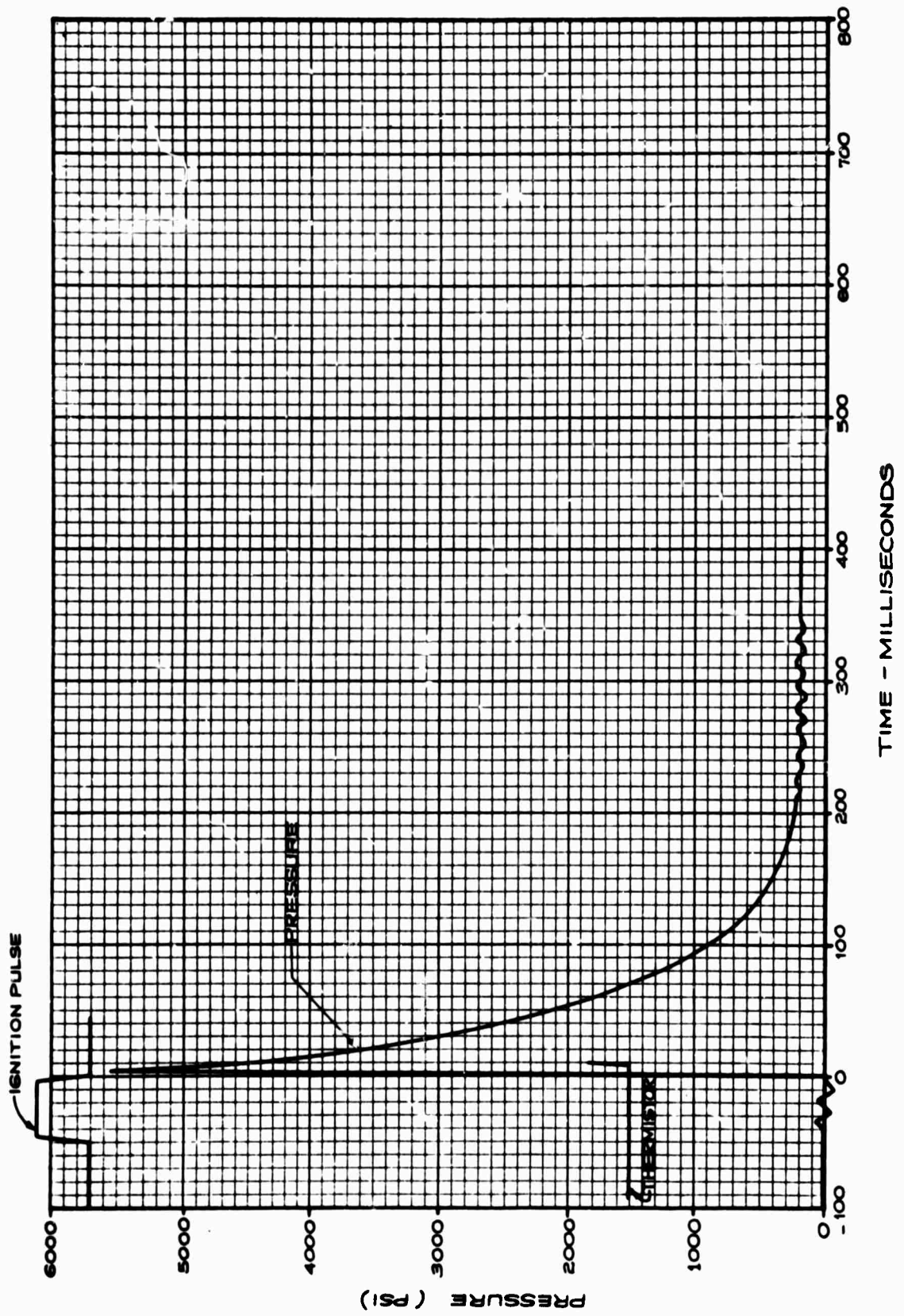

FIGURE 2 309-24-16

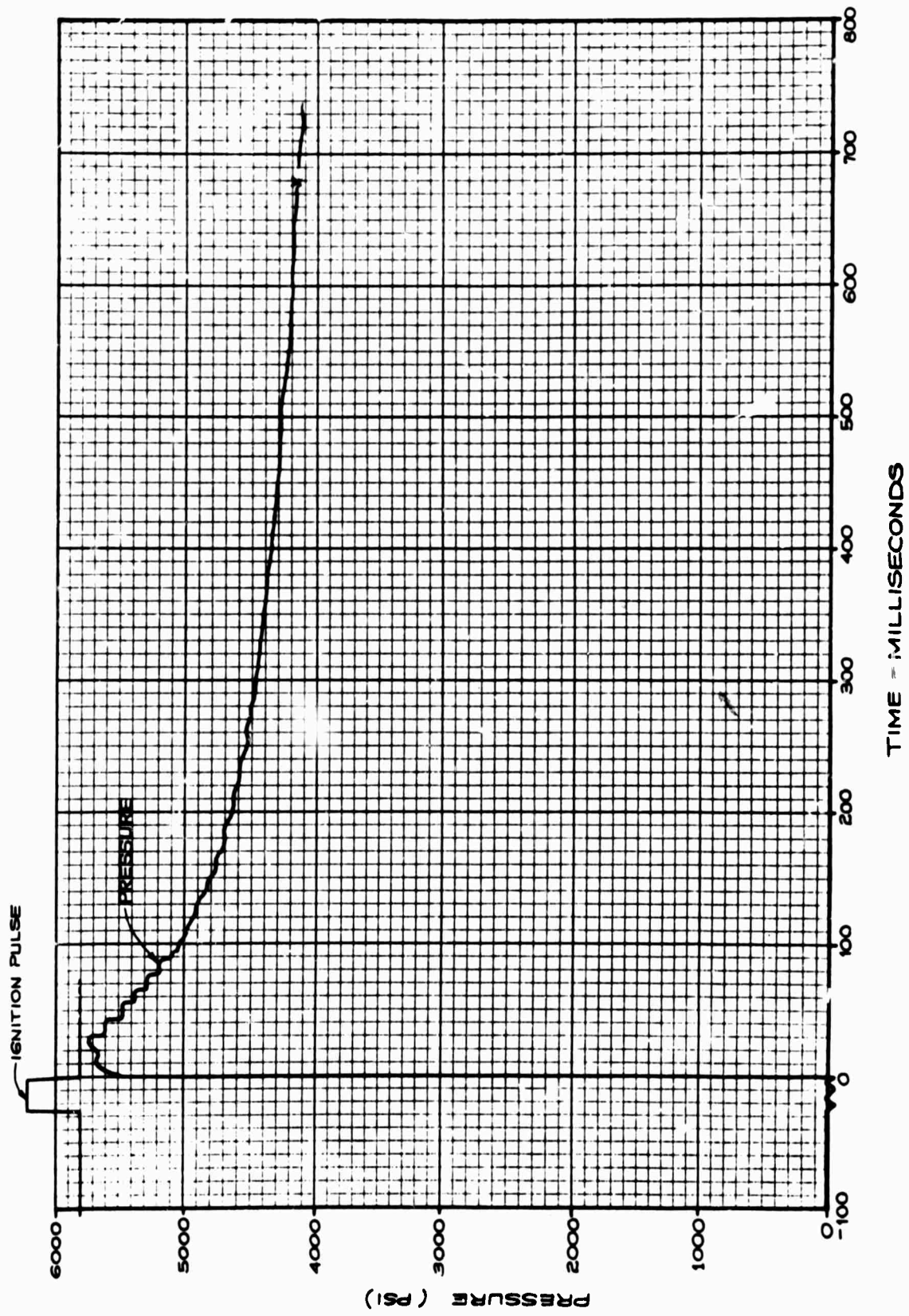
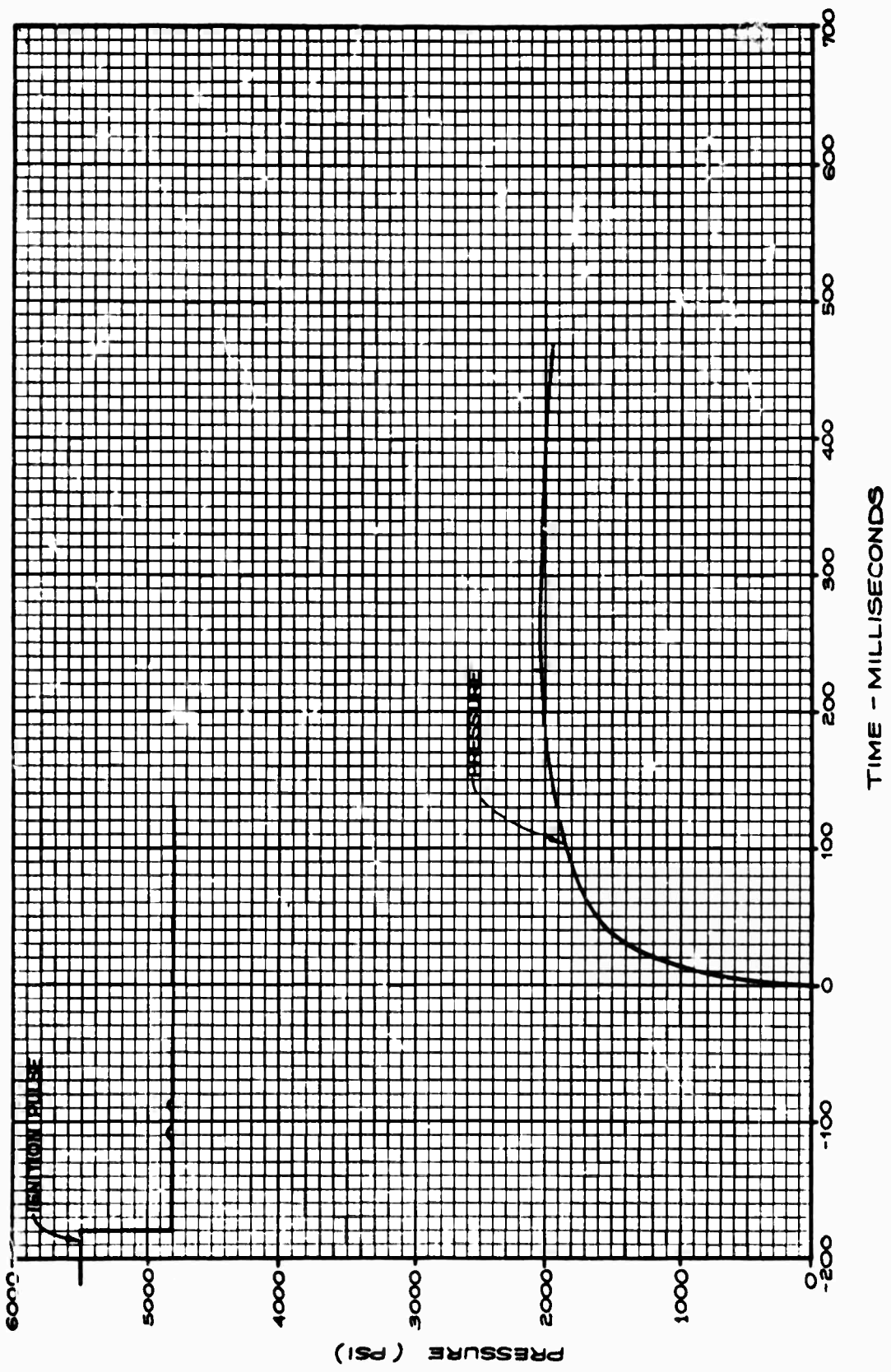

FIGURE 3 309-24-17



TIME - MILLISECONDS

FIGURE 4 309-24-22

A-2030

9-1

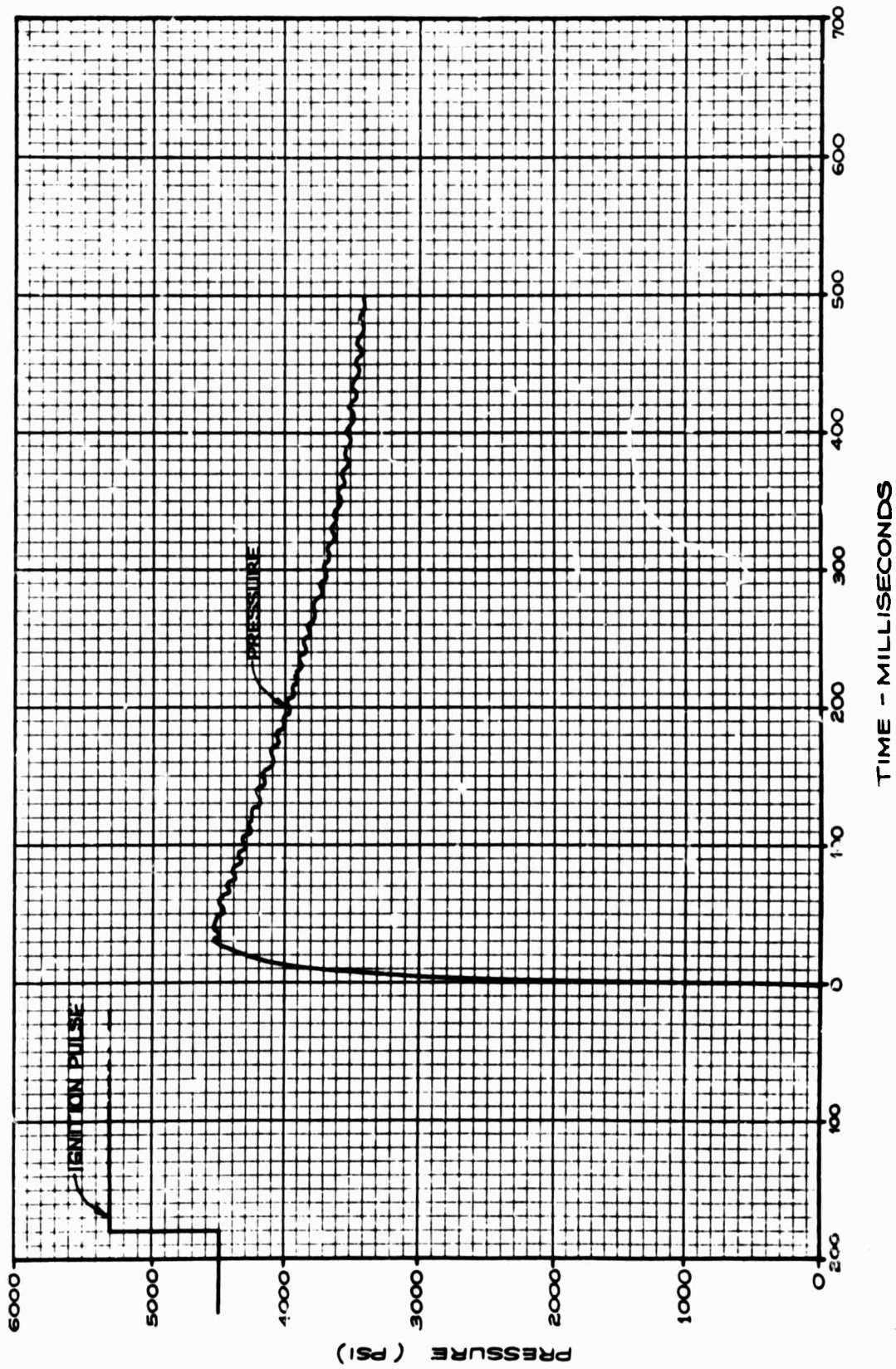

FIGURE 5 309-24-23

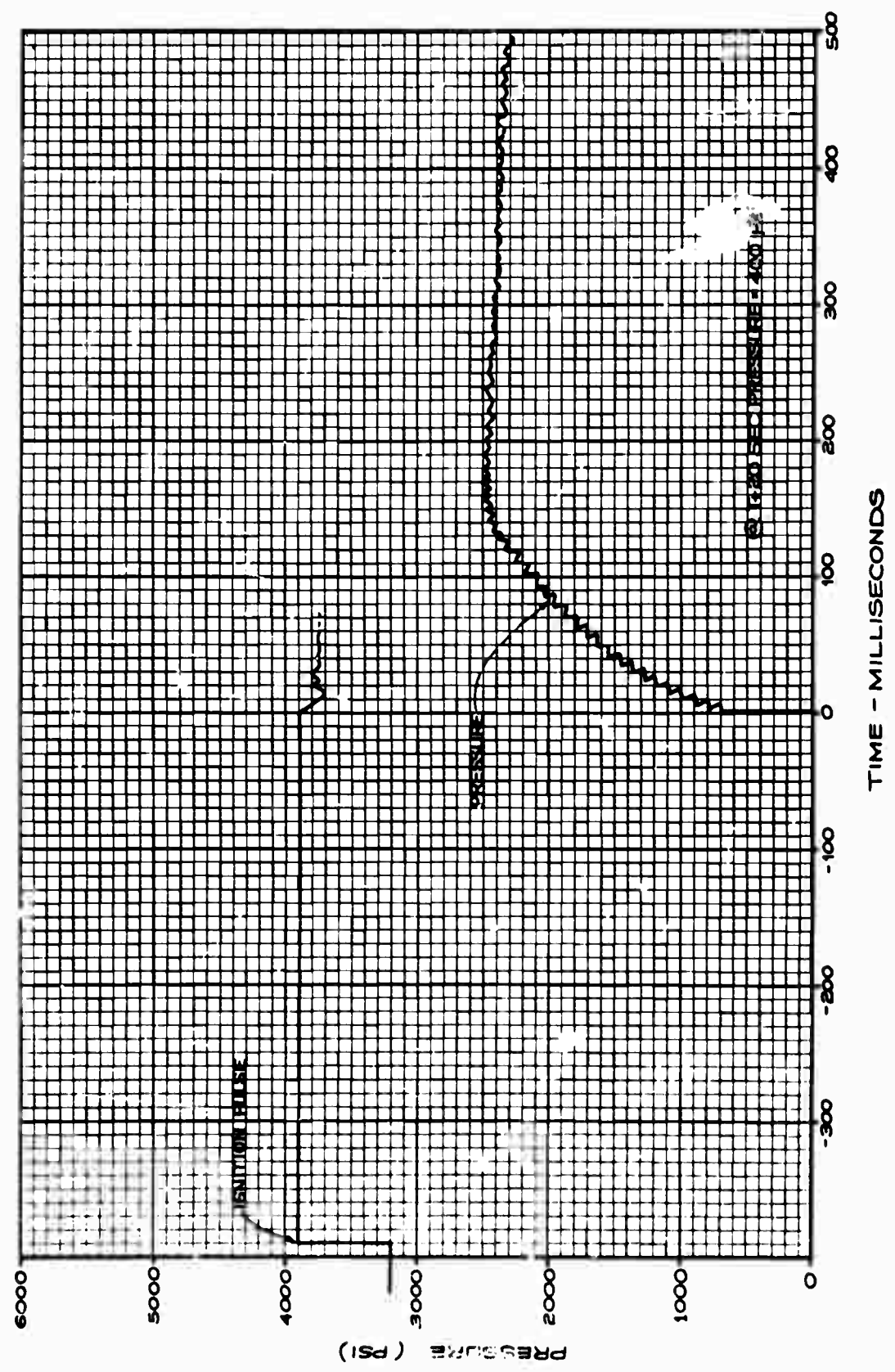

FIGURE 6 309-24-24

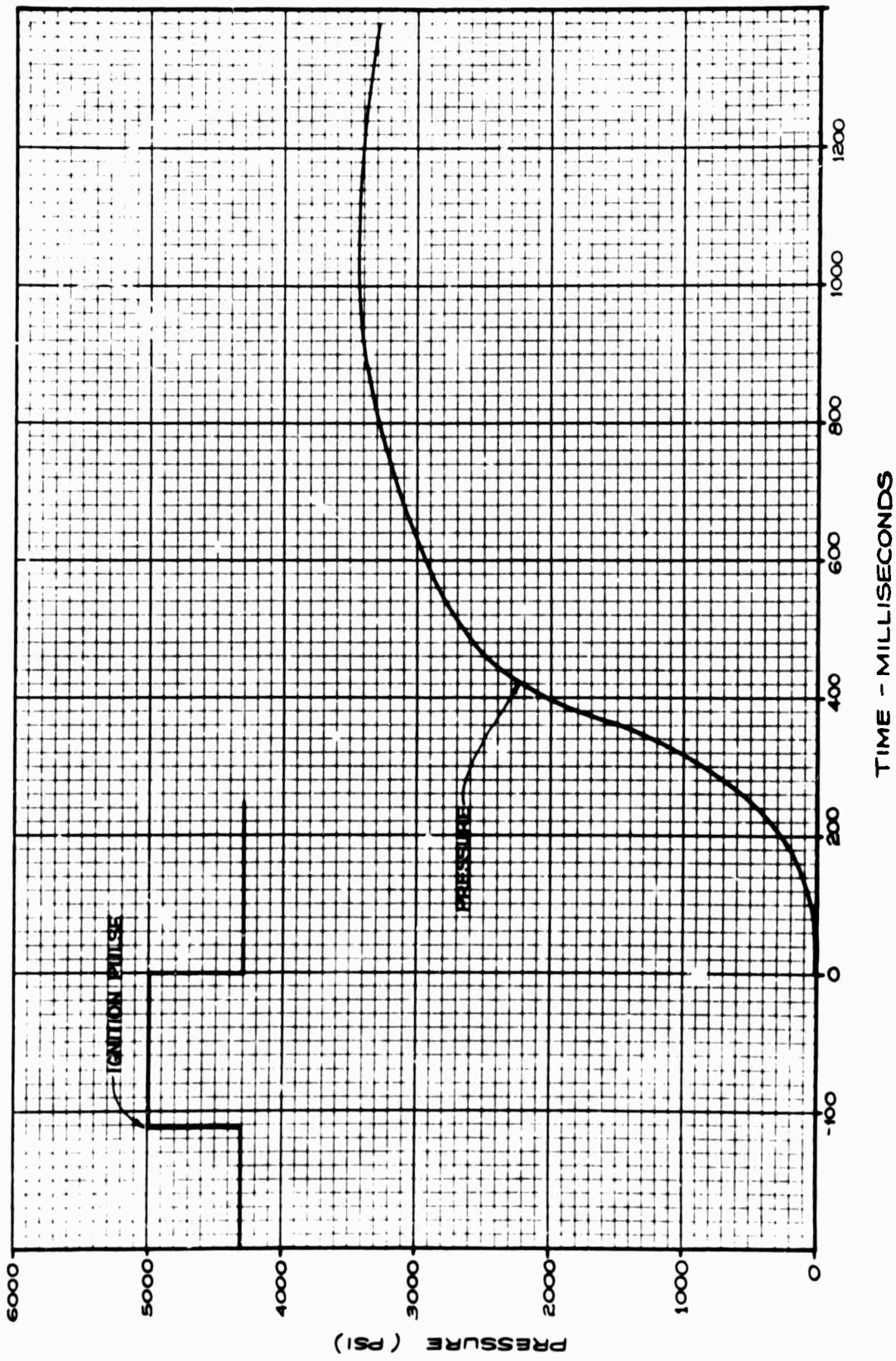

FIGURE 7 309-24-32

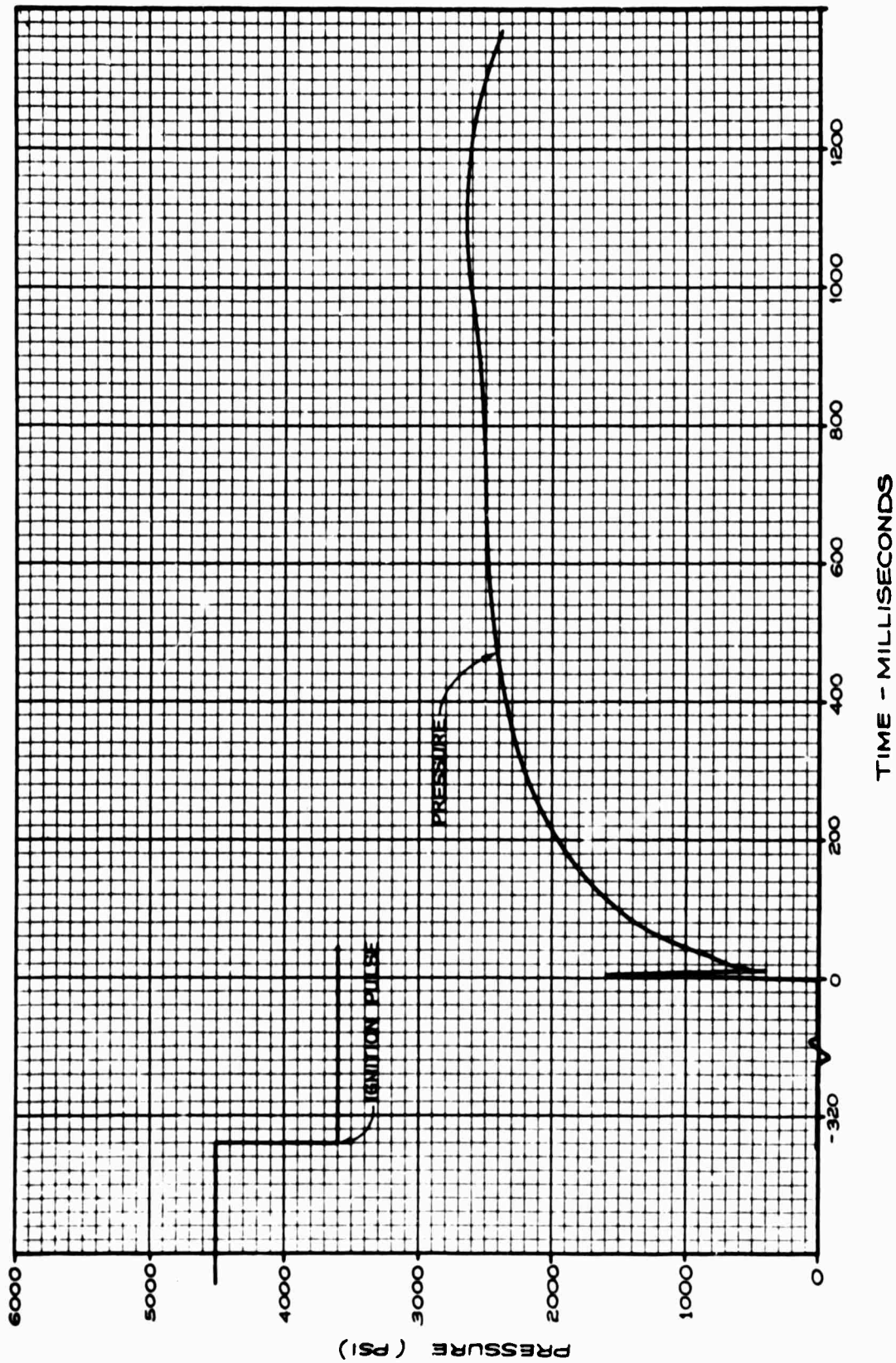
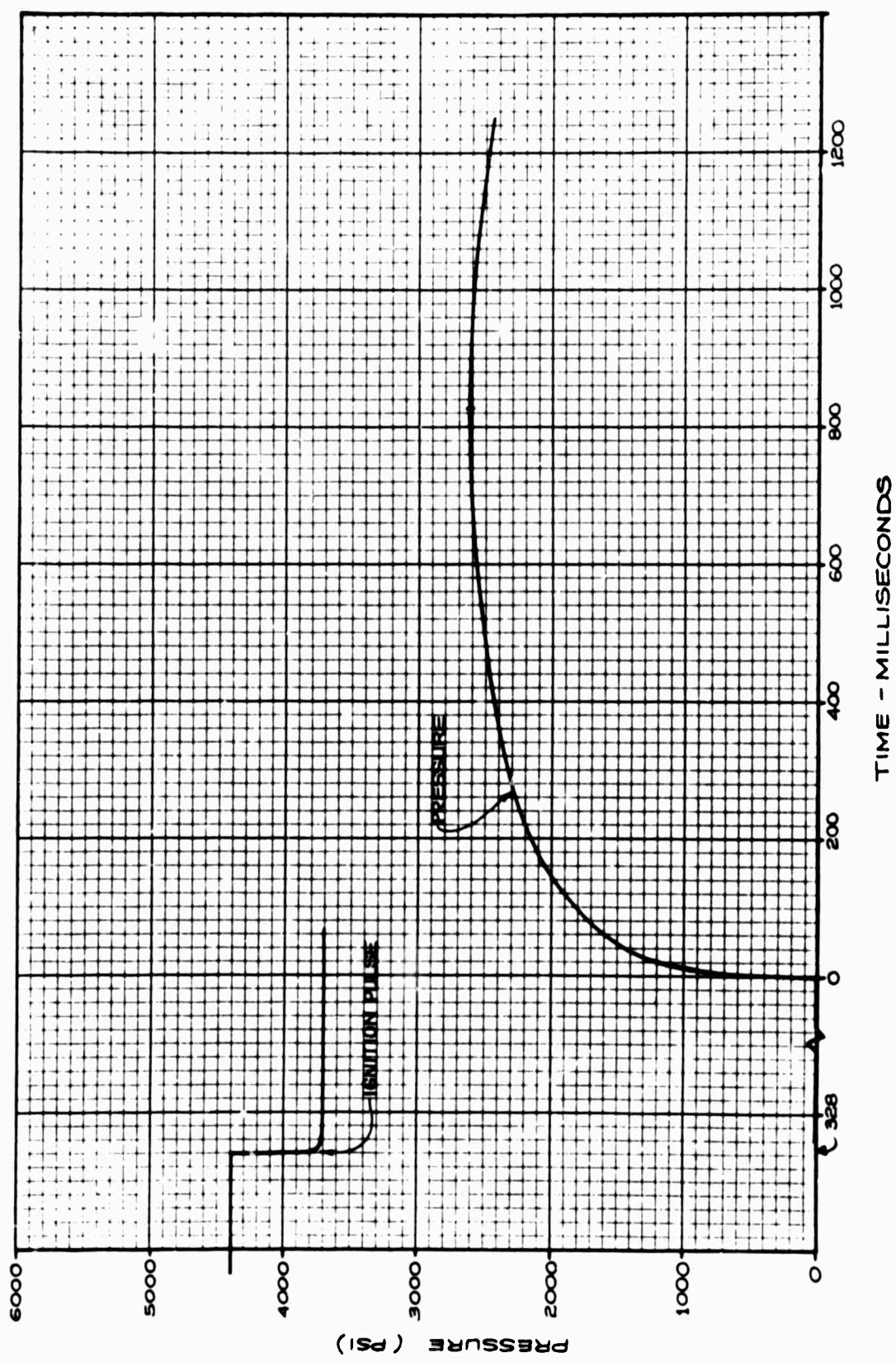
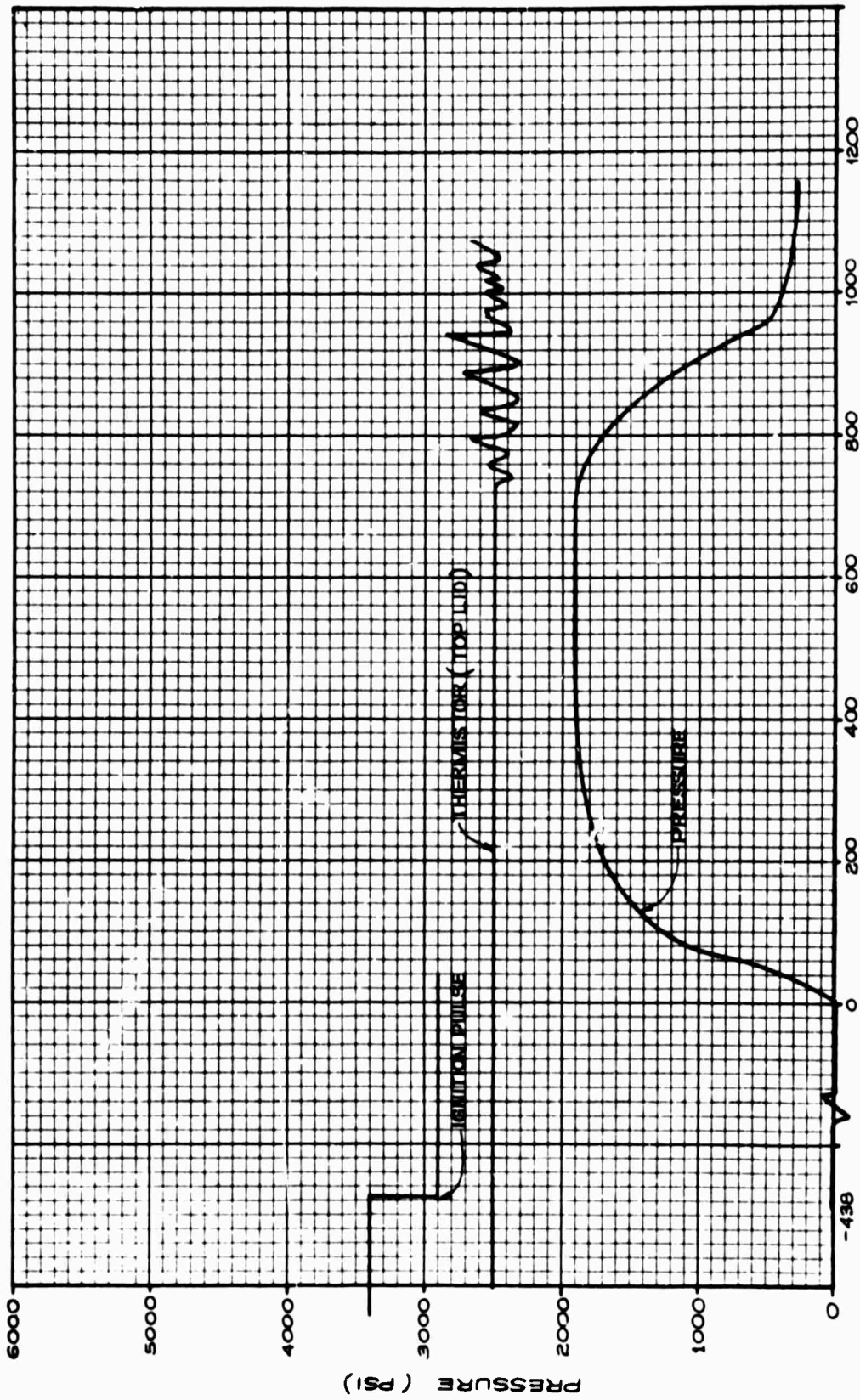

FIGURE 8 309-24-33



FIGURE(9 309-24-34



TIME - MILLISECONDS

FIGURE 10 309-24-35

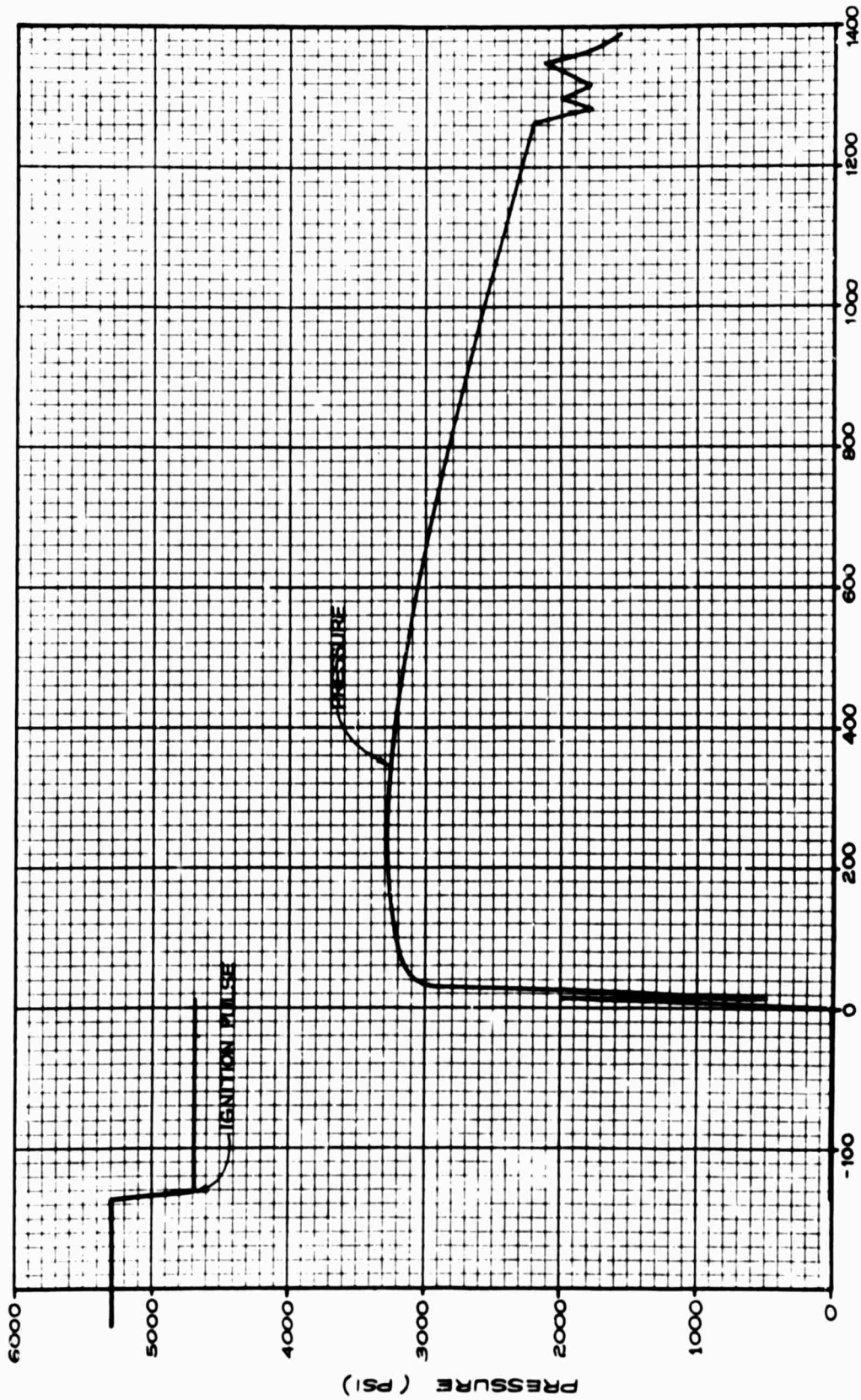
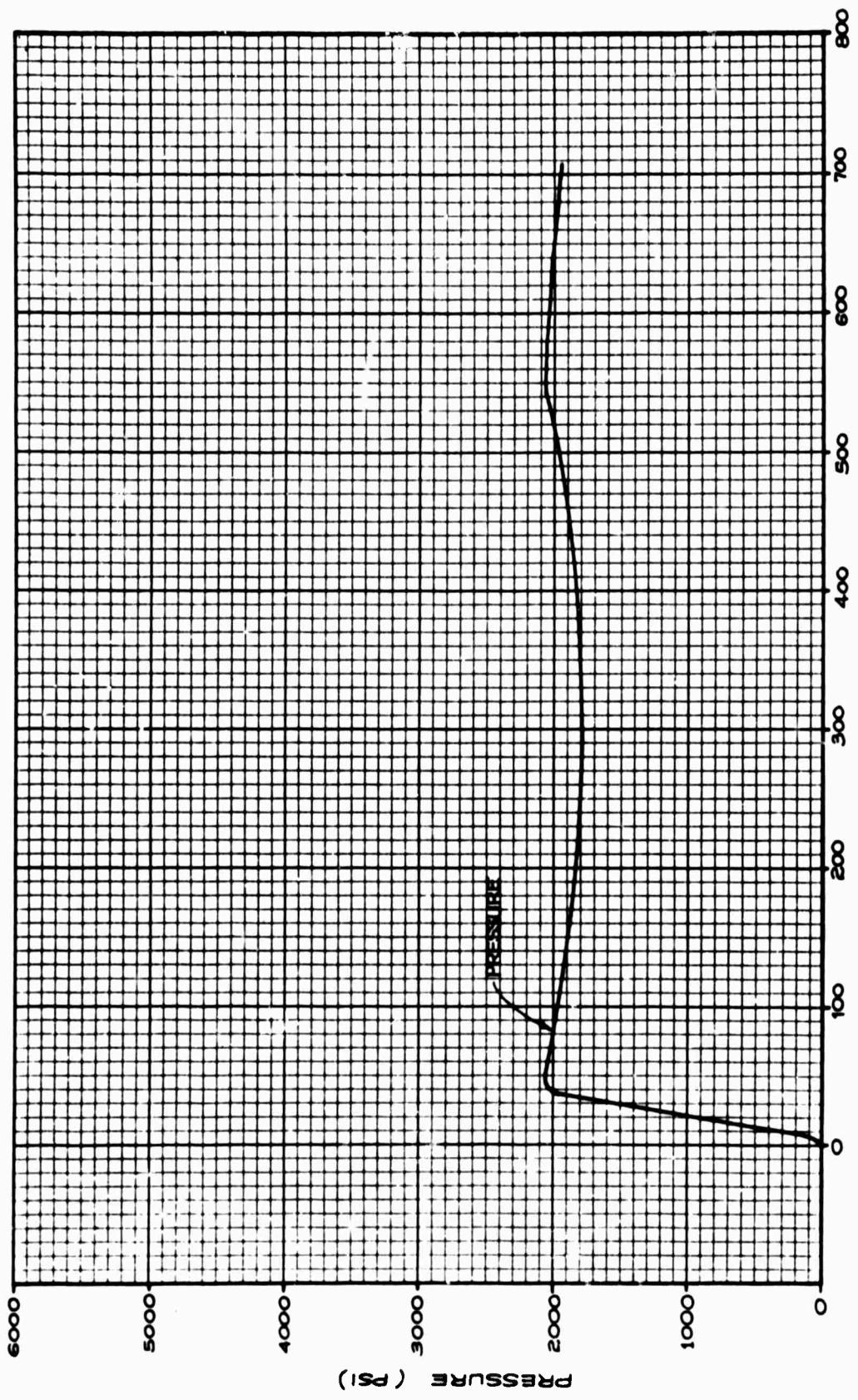

FIGURE 11 309-24-37



TIME - MILLISECONDS

FIGURE 12 309-24-38

A-2038

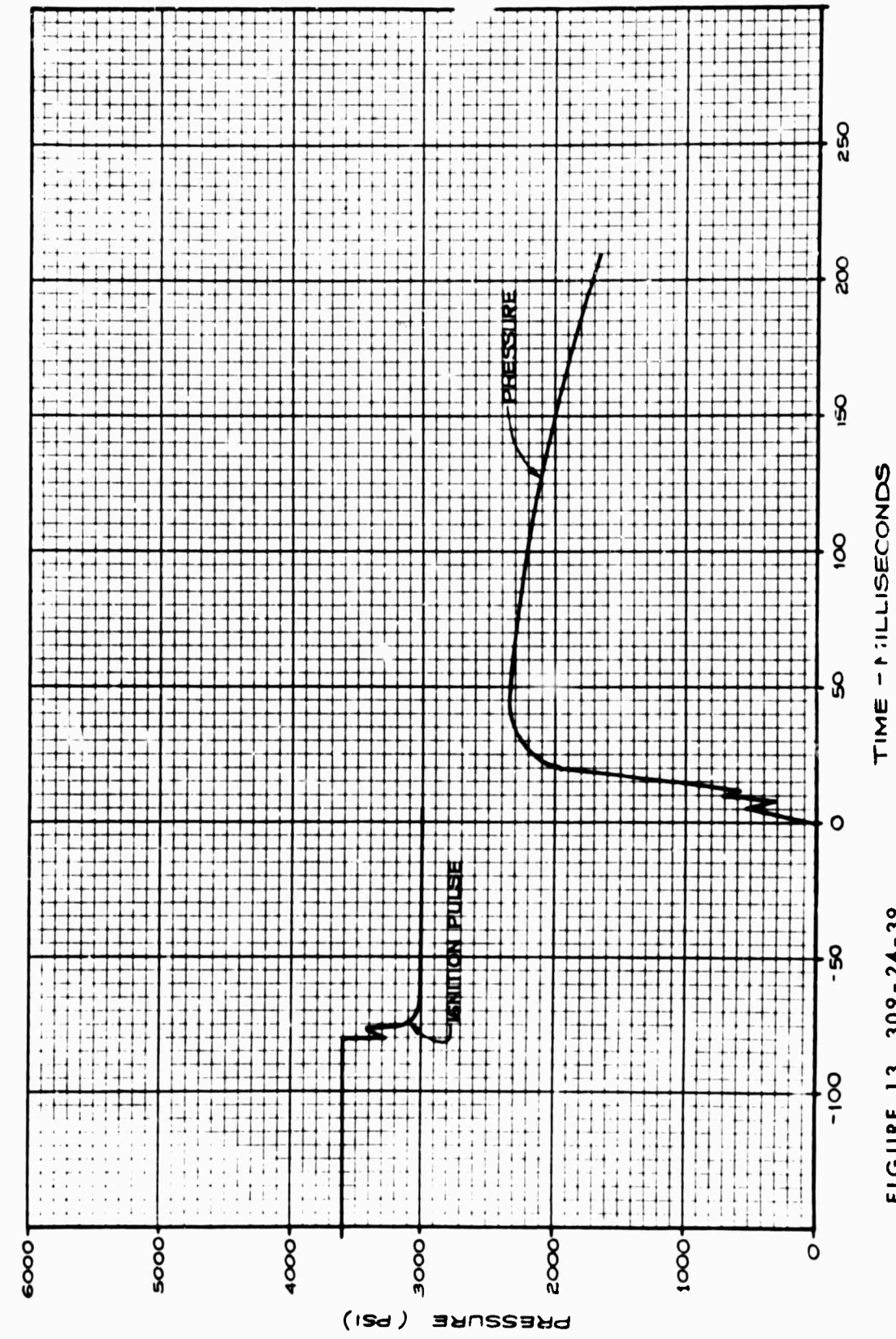

TIME - MILLISECONDS

FIGURE 13 309-24-39



FIGURE 14 309-24-48

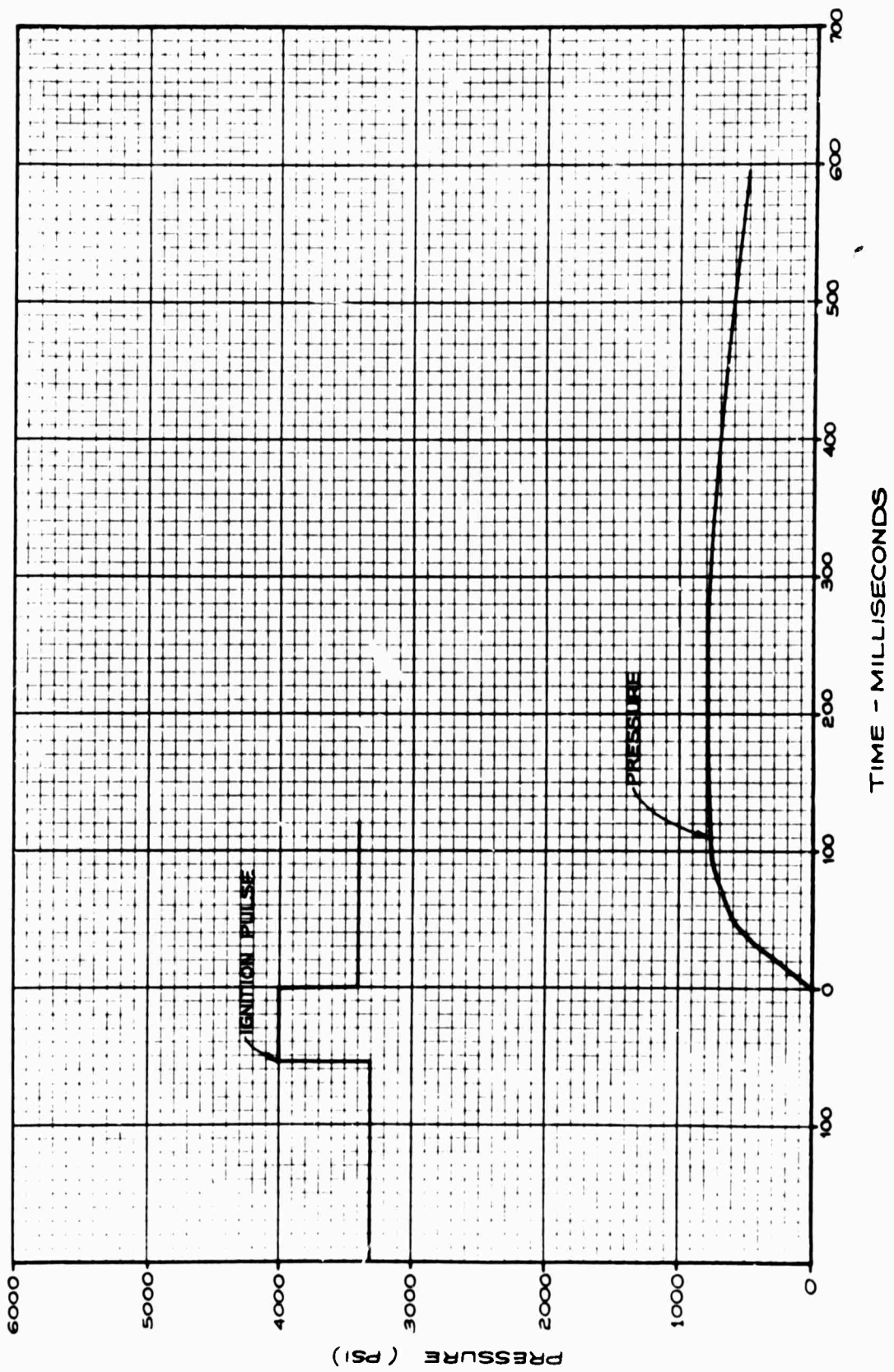

FIGURE 15 309-24-49

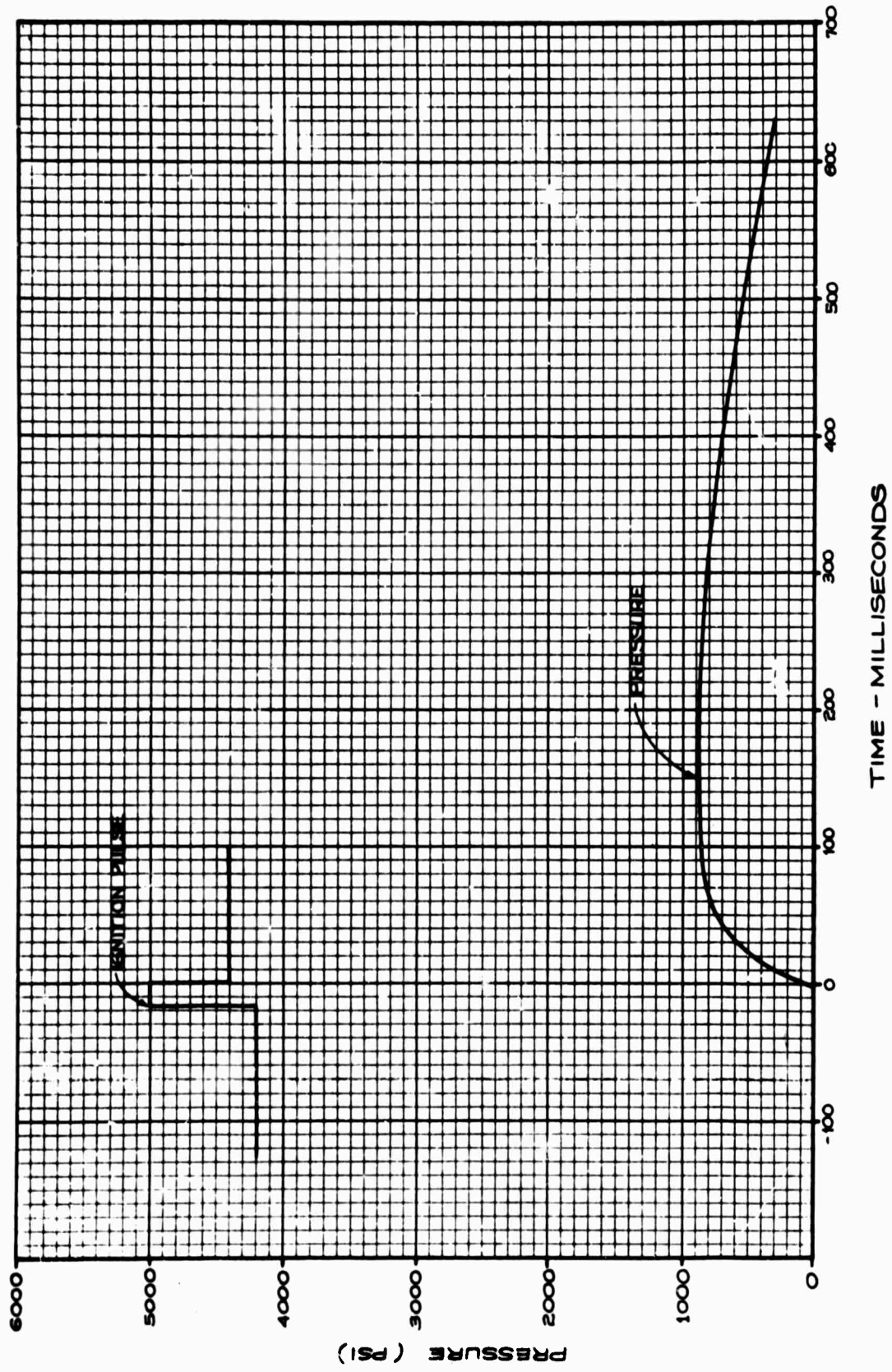

FIGURE 16 309-24-50

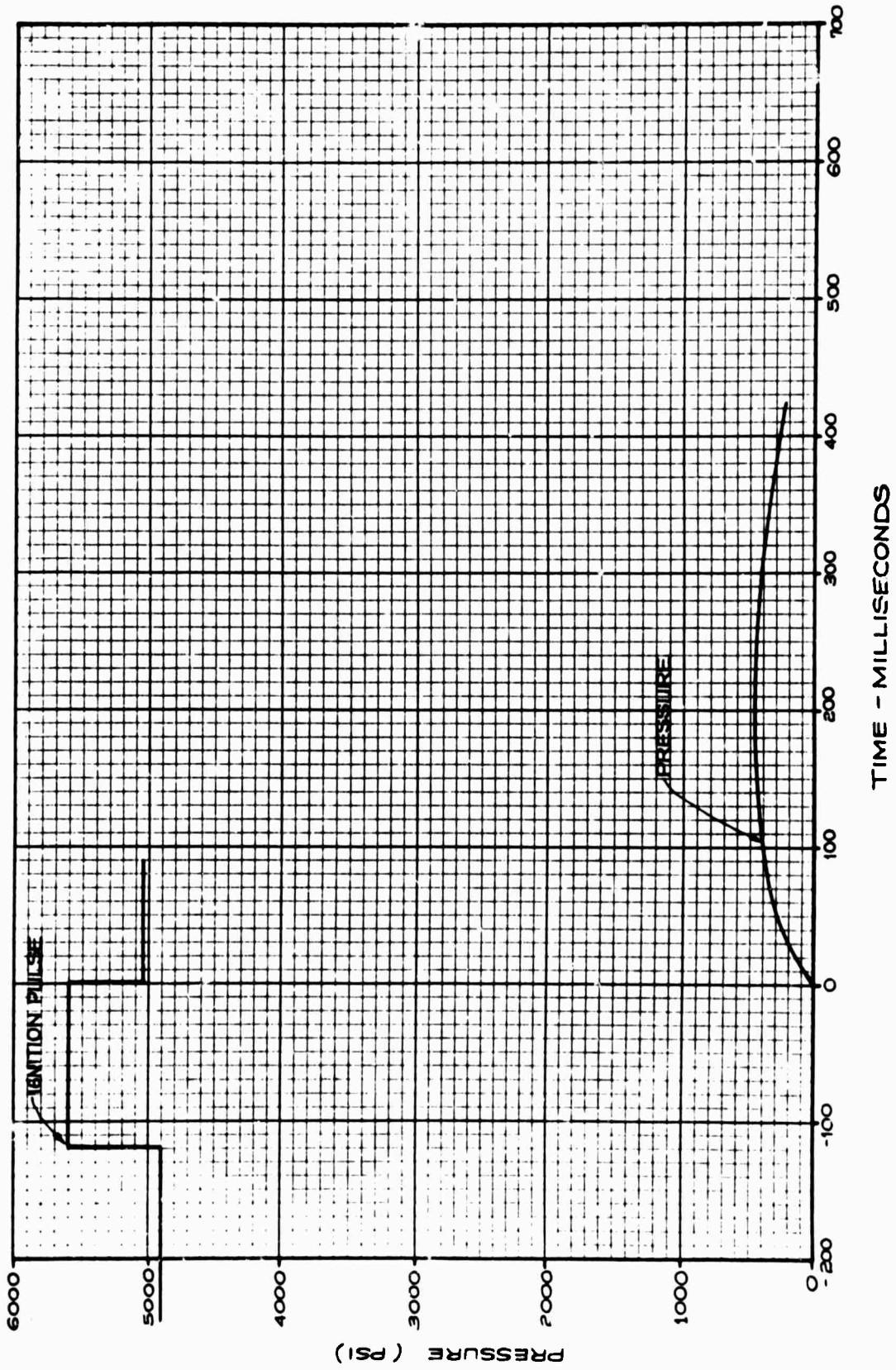

FIGURE 17 309-24-51

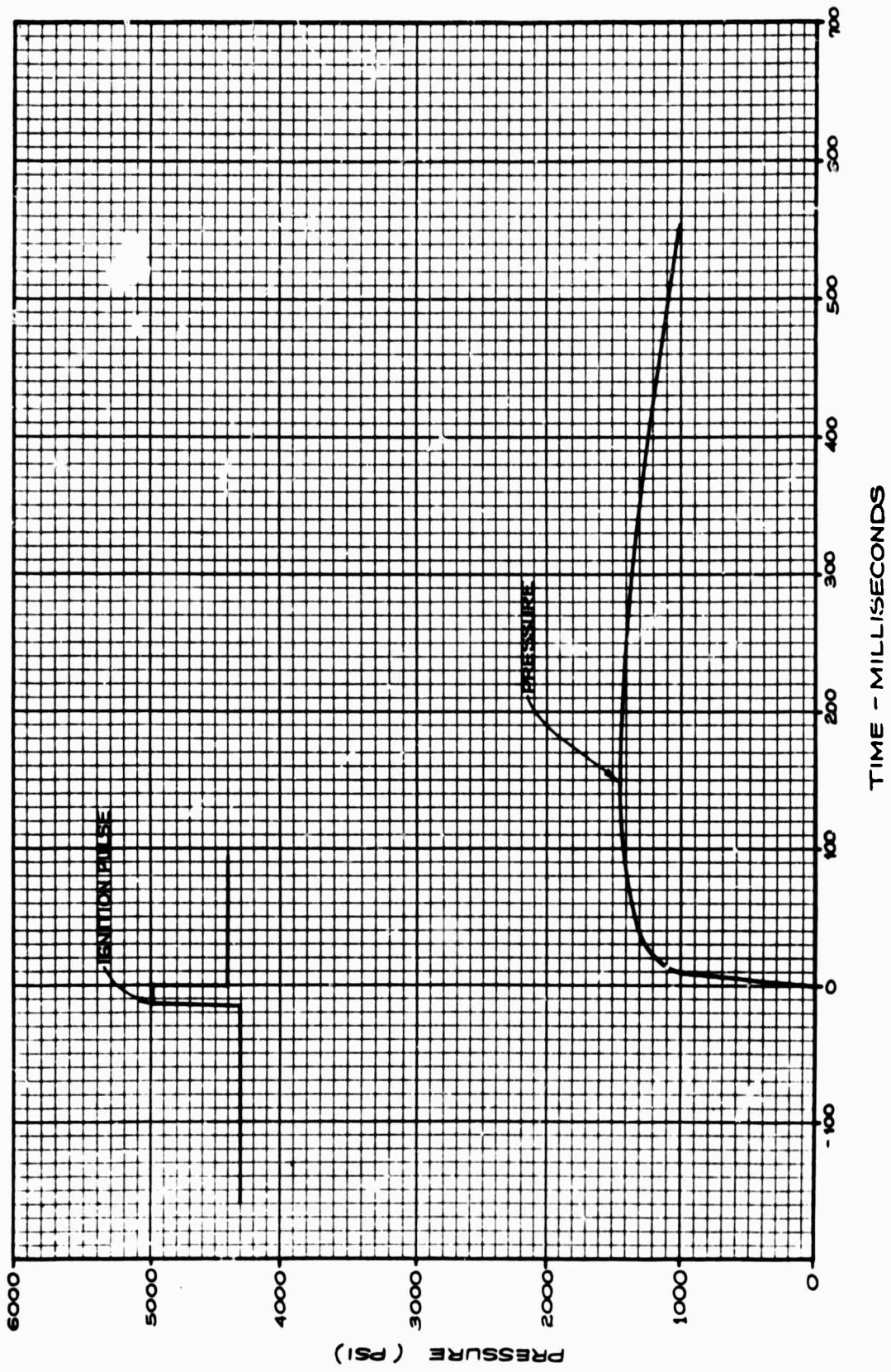

FIGURE 18 309-24-52

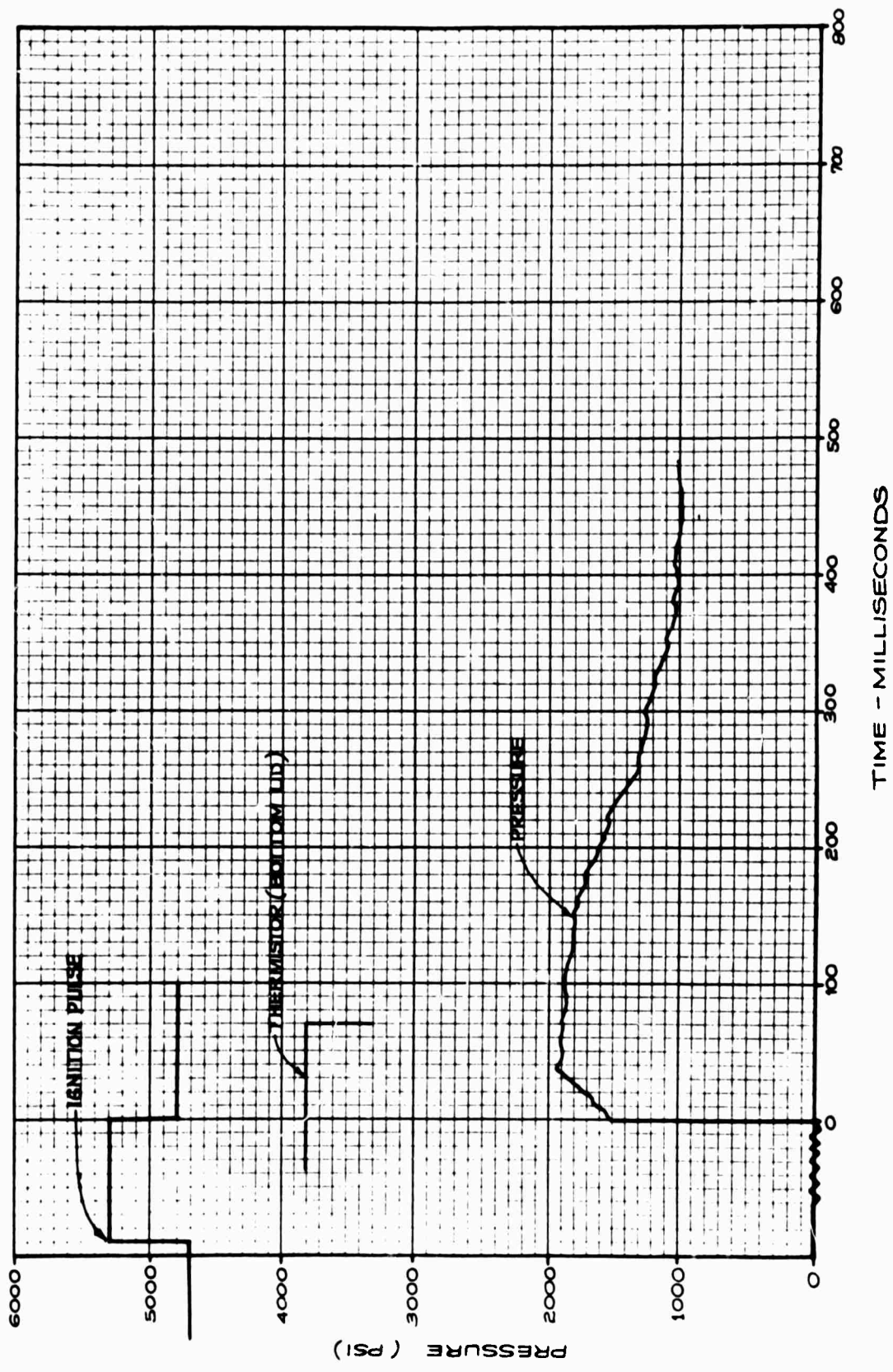

FIGURE 19 319-39-1

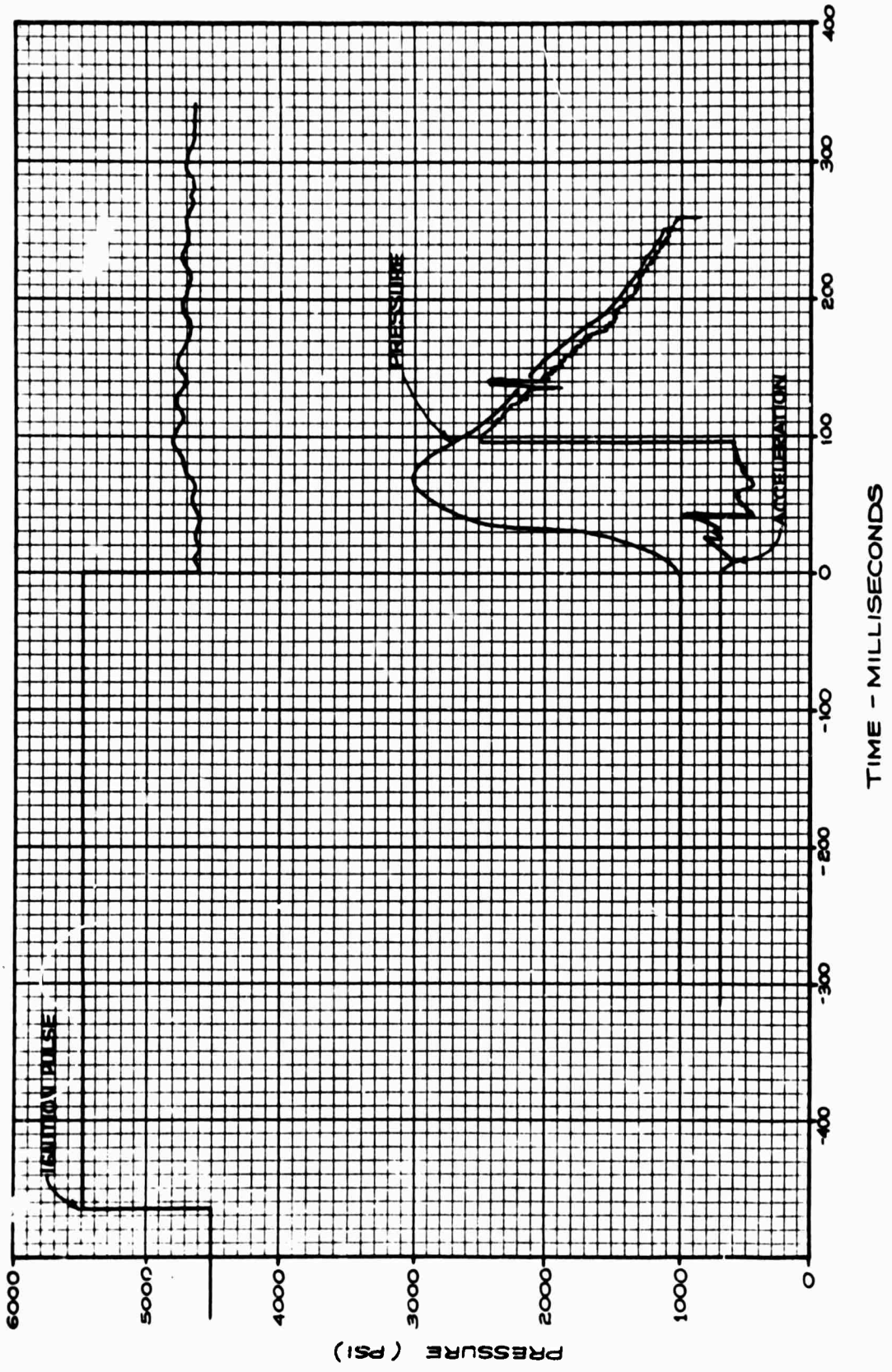

FIGURE 20 319-39-3

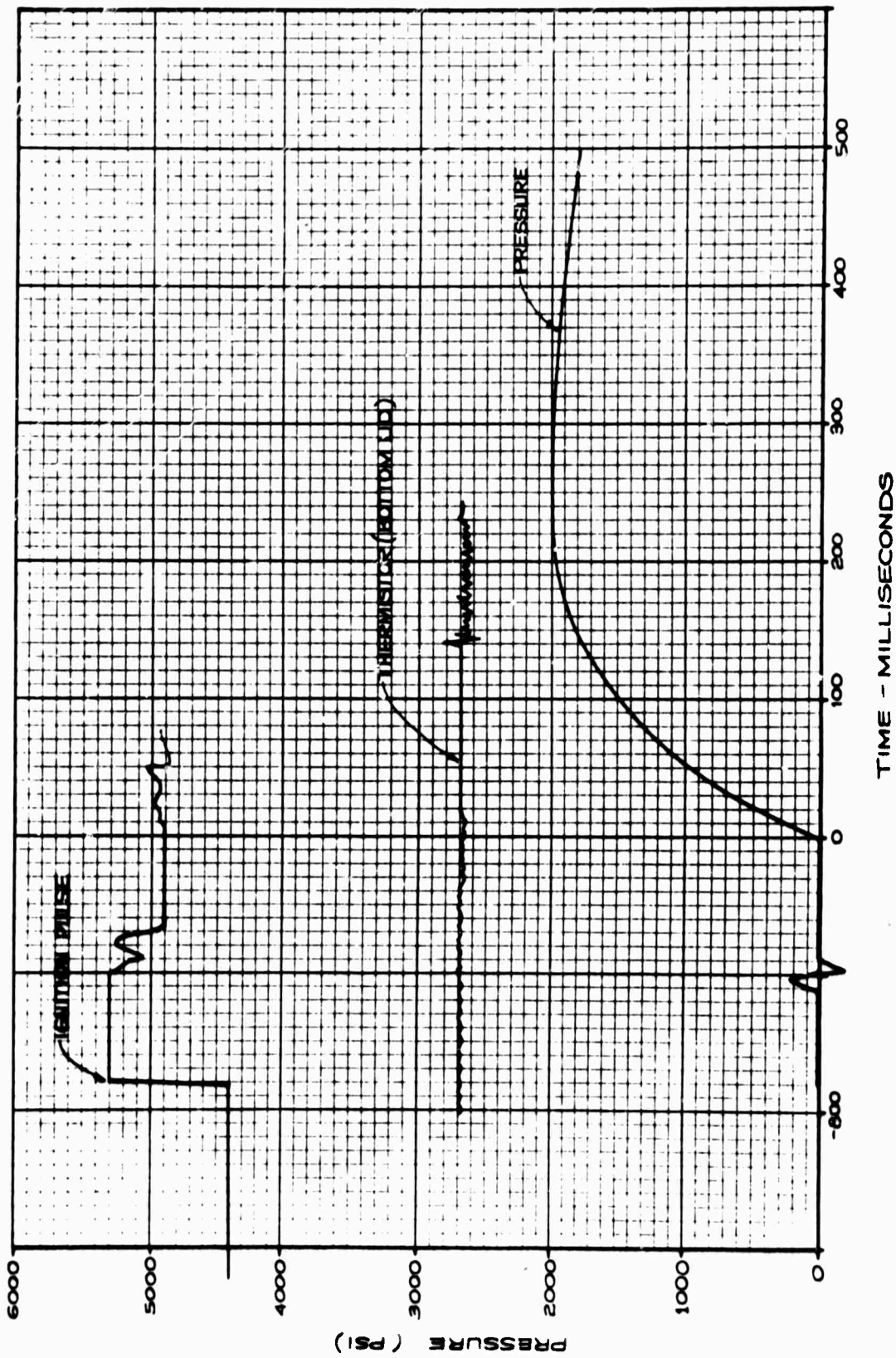

FIGURE 21 319-39-4

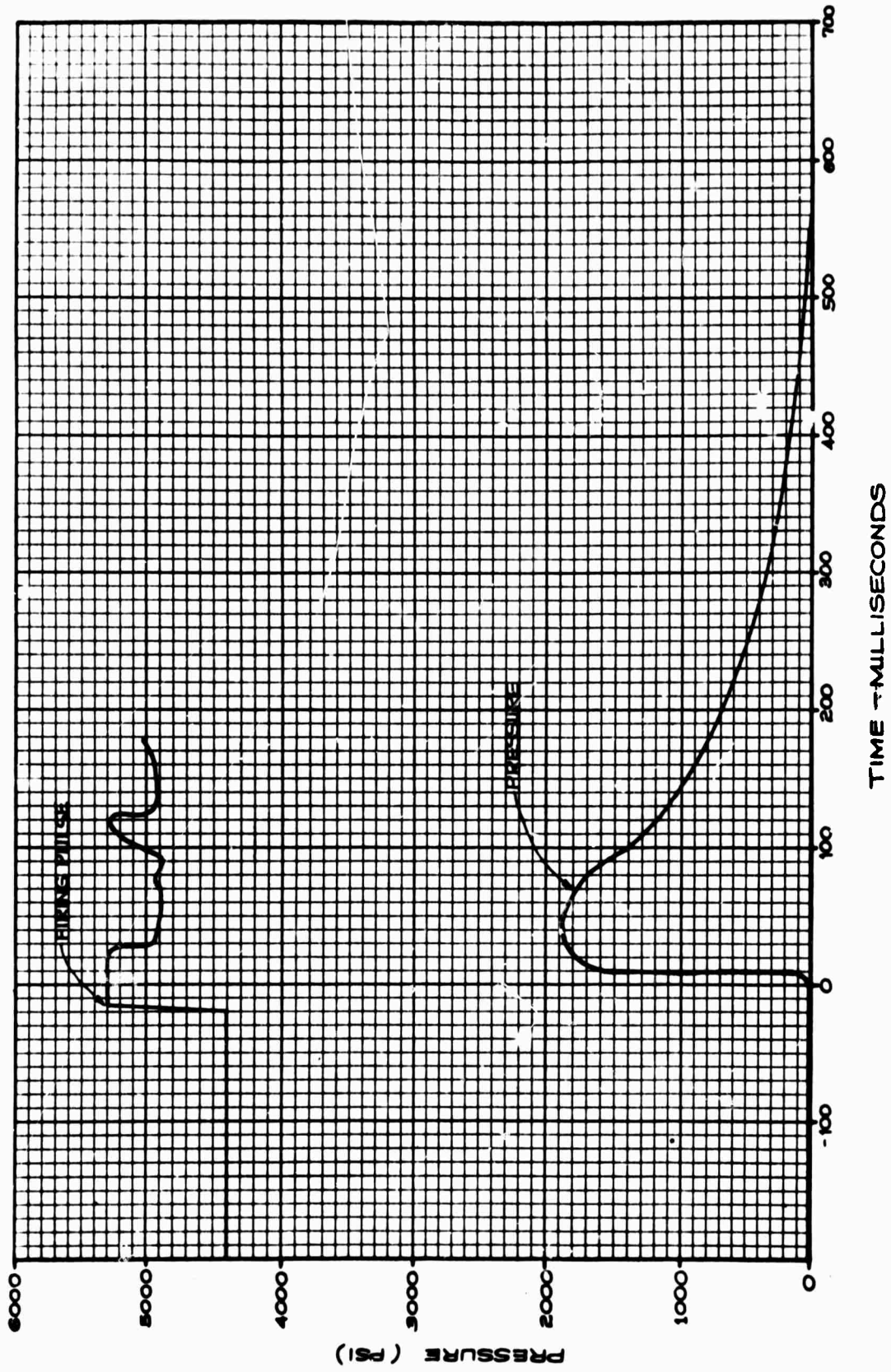

FIGURE 22 333-34-2

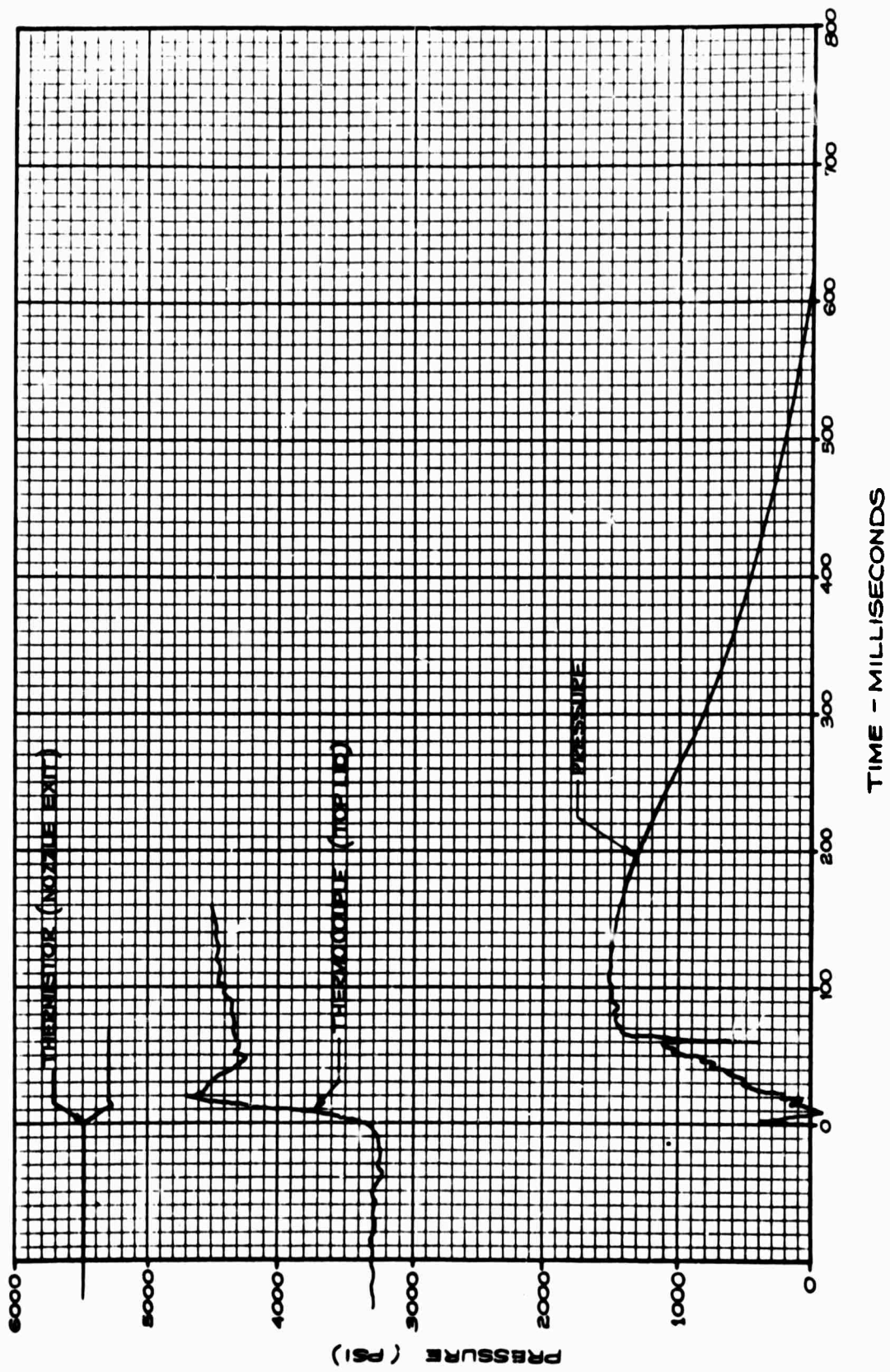

FIGURE 23 333-35-3

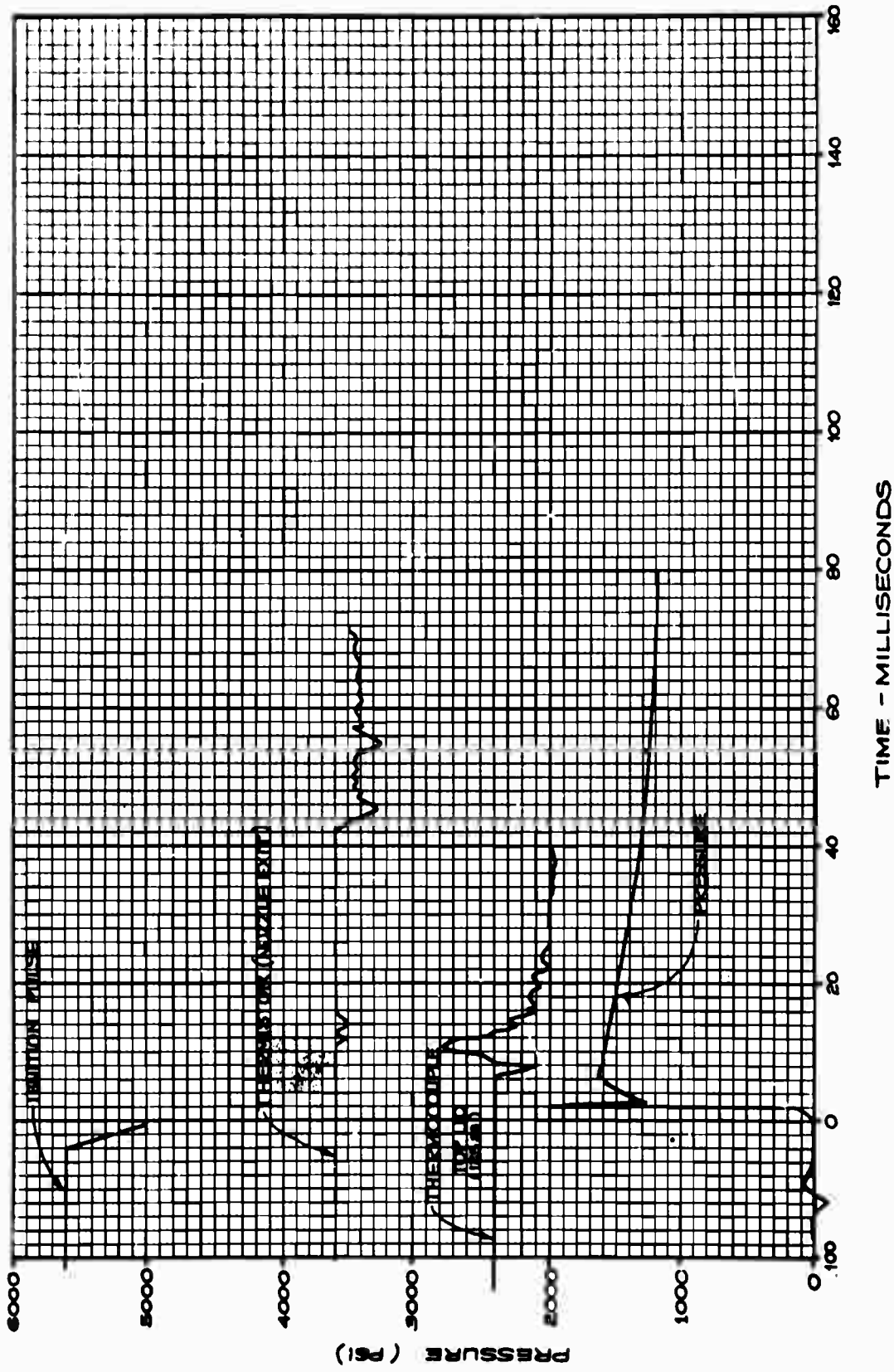

FIGURE 24 333-34-4

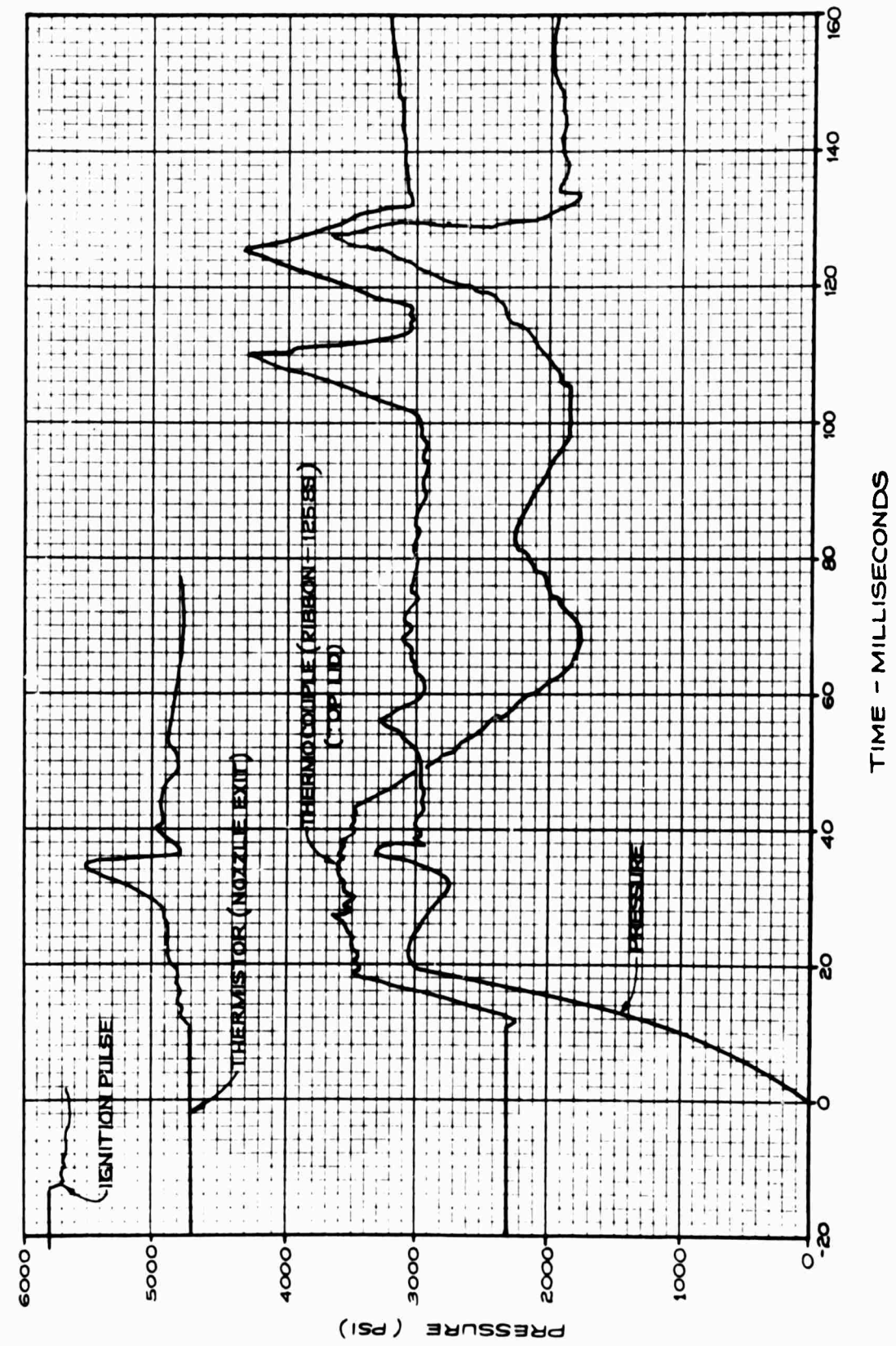

FIGURE 25 333-34-5

**BLANK PAGE**

APPENDIX J

CESIUM NITRATE/ALUMINUM/TUNGSTEN BURNER  
TESTS

## TABLE OF CONTENTS

### 1. GENERAL

### 2. TESTS

- 2.1 CLOSED BOMB
- 2.2 SMALL SCALE BURNER
- 2.3 SHORT FULL DIAMETER BURNER
- 2.4 FULL SCALE PROTOTYPE BURNER
- 2.5 FLIGHT BURNER

### FIGURES

- 1. Flight Configuration
- 2. Closed Bomb Configuration
- 3. Small Scale Configuration
- 4. Full I.D. Short Configuration
- 5. Pressure - Time Record. Test 362-10-4.

### TABLES

- 1. Chemical Formulations
- 2. Closed Bomb Test Summary
- 3. Small Scale Test Summary
- 4. Full I.D. Short Configuration Test Summary
- 5. Full Scale Prototype Test Summary
- 6. Flight Test Summary

1. GENERAL.

A series of ground tests were run on the Cesium Nitrate/Aluminum/Tungsten burner to:

- (1) Optimize chemical formulation
- (2) Determine burn properties including burn time and burn pressure
- (3) Verify burner structural integrity
- (4) Optimize nozzle size and
- (5) Verify reliable ignition at flight altitude

A series of flight tests were conducted to determine r of characteristics of the burner at 30,000 feet altitude.

## 2. TESTS.

The tests were categorized into five series:

| <u>Series</u> | <u>Type of Test</u>  |
|---------------|----------------------|
| I             | Closed Bomb          |
| II            | Small Scale Burner   |
| III           | Short Full Diameter  |
| IV            | Full Scale Prototype |
| V             | Flight Test          |

The flight burner is illustrated in Figure 1. Table 1 gives chemical formulations.

### 2.1 Series I - Closed Bomb Tests.

This test series was conducted to determine if the chemical formulation would generate sufficient pressure for self-sustaining operation. The test device configuration is shown in Figure 2. A summary of the closed bomb tests is presented in Table 2. The results of the series I tests indicate that the chemical mixture could be ignited and burning sustained until the thermitic was completely reacted.

### 2.2 Series II - Small Scale Tests.

A series of small scale unit tests were conducted with various chemical formulations (Table 1), void volumes, port sizes and igniter changes to optimize the system. The series II test device configuration is presented in Figure 3. Chemical mixes were press loaded to 5000 psi or 9800 psi. In certain tests, an increment of 2% wax was added to the mix, however, the addition of the wax resulted in a total of four detonations. The detonations were attributed to the formation of wax vaporization gases.

Two special mixtures containing boron potassium nitrate were tested in an effort to promote a higher burning pressure and rate. No noticeable increase in burning pressure or rate was indicated.

Several ignition misfires were experienced during this test series, so various igniter designs were tested. The test results indicated that an igniter booster containing a 50-50 mix of .125 x .125 inch polysulphide propellant chips and Naval gun propellant powder gave no misfires. A summary of the small scale tests is presented in Table 3.

### 2.3 Series III - Short Full Diameter Tests.

As a result of the test results of the series II tests, the flight chemical formulation and the approximate nozzle port size were selected. The objectives of the series III tests were to define the burning pressure and burning rate of the chemical. The test device, shown in Figure 4, featured a foreshortened length. However, the housing diameters and port size were flight type. In certain tests the pressure was monitored with a pressure gauge while other test devices were instrumented with pressure transducers and the pressure was recorded on a visicorder oscillograph. Table 4 presents a summary of the series III test results.

### 2.4 Series IV - Full Scale Prototype Tests.

The objectives of these tests were to verify the payload structural integrity including nozzle design. One test was conducted in a vacuum chamber (-28 inches of Mercury gauge) to verify ignition at simulated flight altitudes.

Canister burn through occurred during the first two tests indicating a requirement for additional canister insulation. A combination of asbestos and steel liner for the mix was added to the inside of the canister. Ground tests conducted with the new insulation were satisfactory. Figure 1 illustrates the full scale prototype device. Table 5 presents the summary of the series IV test results.

### 2.5 Series V - Flight Tests.

A series of 12 flight tests were conducted from Eglin Air Force Base, Florida, to test the units in a flight environment and evaluate the RF effects of the generator. Table 6 presents a summary of the flight tests.

Flight test units performed according to design except for 362-10-8 which did not ignite. During the post mortem it could not be ascertained whether the delay igniter received an ignition pulse or whether the failure was within the ignition system itself. A second failure occurred on 362-10-25 where burn time was recorded as 4 seconds.

2.5.1 Vehicle System. Space Data Corporation conducted an aerodynamic analysis of the Loki vehicle system and the ion generator payload (362-10) to determine vehicle stability and performance. The analysis indicated that the vehicle performance was quite insensitive to payload weight and peak altitude ranged from 27 to 32,000 feet with payload weight variations between 40 and 50 pounds respectively, thus satisfying the technical requirements of this program.

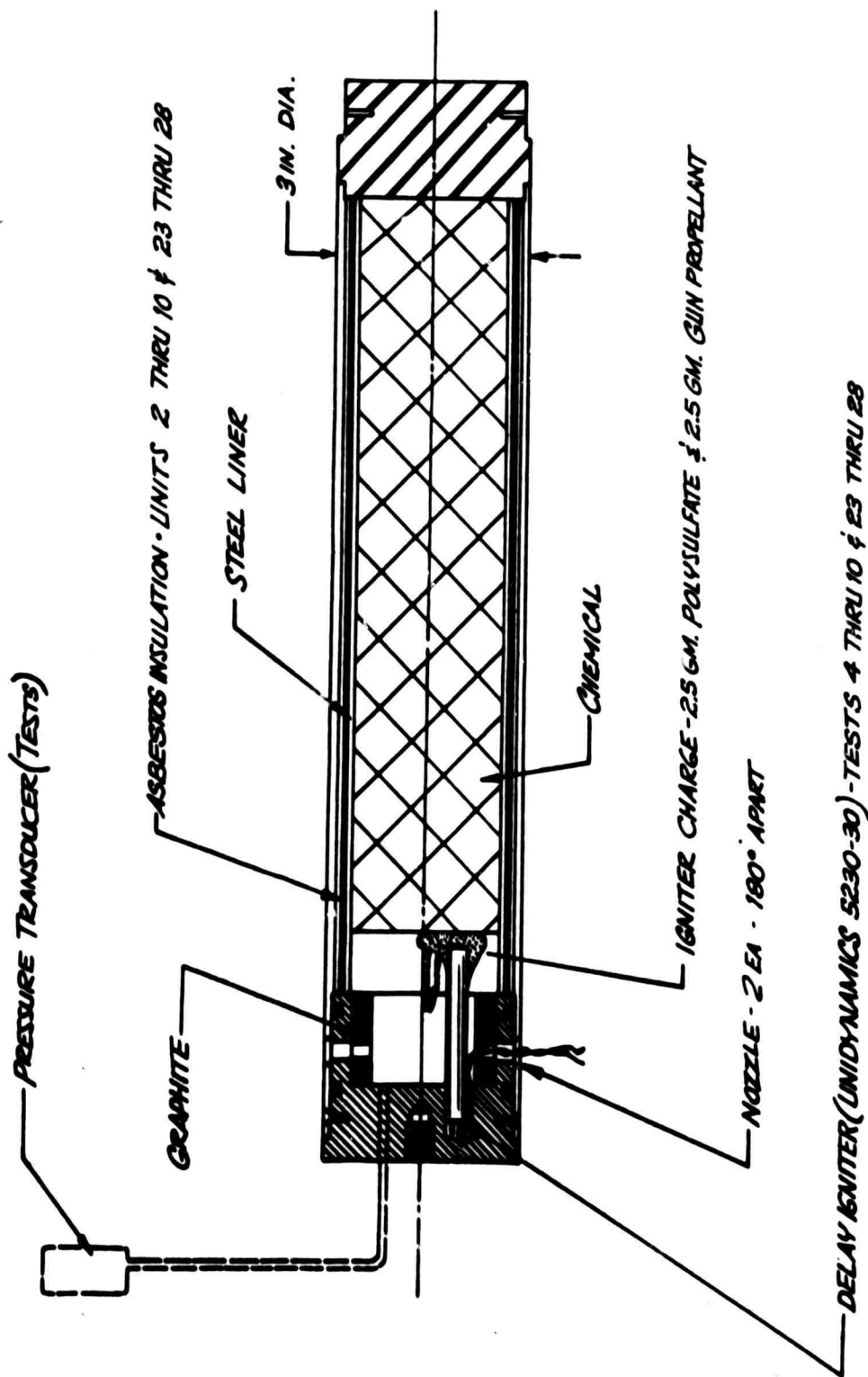
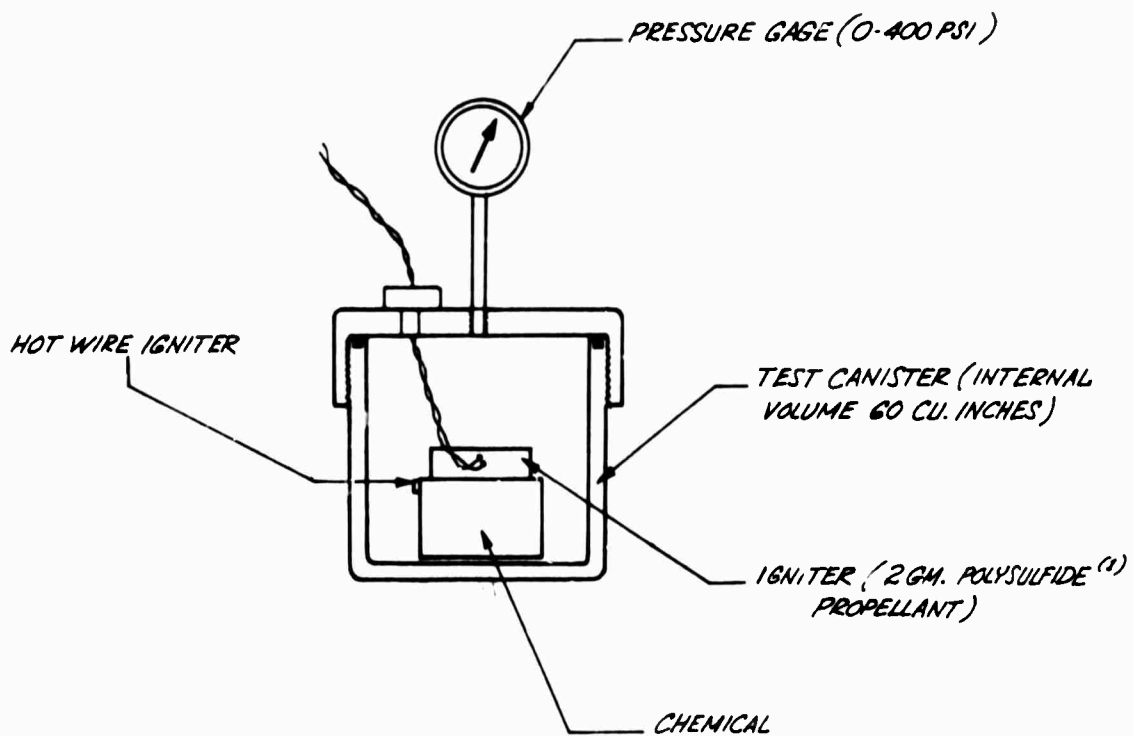

FIGURE 1 CESIUM NITRATE/ALUMINUM/TUNGSTEN BURNER -  
 FLIGHT CONFIGURATION

TABLE I  
CESIUM NITRATE/ALUMINUM/TUNGSTEN  
BURNER FORMULATIONS

| <u>MIX</u> | <u>PERCENTAGE</u>             | <u>CHEMICAL</u>   |
|------------|-------------------------------|---|
| 1          | 76%<br>22%<br>2%              | C <sub>5</sub> NO <sub>3</sub><br>Al<br>Paraffin                    |
| 2          | 43%<br>34%<br>21%<br>2%       | WO <sub>3</sub><br>C <sub>5</sub> NO <sub>3</sub><br>Al<br>Paraffin |
| 3          | 44%<br>37%<br>19%             | WO <sub>3</sub><br>C <sub>5</sub> NO <sub>3</sub><br>Al             |
| 4          | 19%<br>81%                    | Al<br>WO <sub>3</sub>   |
| 5          | 16%<br>66%<br>18%             | W<br>C <sub>5</sub> NO <sub>3</sub><br>Al                           |
| 6          | 40%<br>33.7%<br>17.3%<br>9.0% | WO <sub>3</sub><br>C <sub>5</sub> NO <sub>3</sub><br>Al<br>W        |
| 7          | 15.8%<br>67.5%<br>16.7%       | Al<br>WO <sub>3</sub><br>W  |
| 8          | 36.5%<br>31.5%<br>17%<br>15%  | WO <sub>3</sub><br>C <sub>5</sub> NO <sub>3</sub><br>Al<br>W        |

| <u>MIX</u> | <u>PERCENTAGE</u>            | <u>CHEMICAL</u>  |
|------------|------------------------------|--|
| 9          | 41.8%<br>35.2<br>19%<br>5%   | WO <sub>3</sub><br>C <sub>5</sub> NO <sub>3</sub><br>Al<br>W |
| 10         | 35%<br>29.6%<br>15.4%<br>20% | WO <sub>3</sub><br>C <sub>5</sub> NO <sub>3</sub><br>Al<br>W |
| 11         | 33%<br>28%<br>14%<br>25%     | WO <sub>3</sub><br>C <sub>5</sub> NO <sub>3</sub><br>Al<br>W |



(1) AMMONIUM PERCHLORATE POLYSULFIDE

FIGURE 2  
CLOSED BOMB CONFIGURATION

TABLE 2  
CLOSED BOMB TEST SUMMARY

| <u>TEST</u> | <u>CHEMICAL MIX</u> | <u>CHEMICAL WT (gm)</u> | <u>BURN PRESSURE psi</u> |
|-------------|---------------------|-------------------------|--------------------------|
| 1           |                     | 0                       | 115                      |
| 2           | 1                   | 10                      | 240                      |
| 3           | 1                   | 10                      | 175                      |
| 4           | 1                   | 10                      | -                        |
| 5           | 1                   | 10                      | 175                      |
| 6           | 1                   | 10                      | 160                      |
| 7           | 1                   | 10                      | 190                      |
| 8           | 1                   | 10                      | 189                      |
| 9           | 1                   | 10                      | 180                      |
| 10          | 1                   | 17                      | 200                      |
| 11          | 1                   | 17                      | 270                      |
| 12          | 3                   | 9                       | 300                      |
| 13          | 3                   | 10                      | 400                      |

NOTE: Test 2 - Forming pressure 5000 psi, all others 10,000 psi.

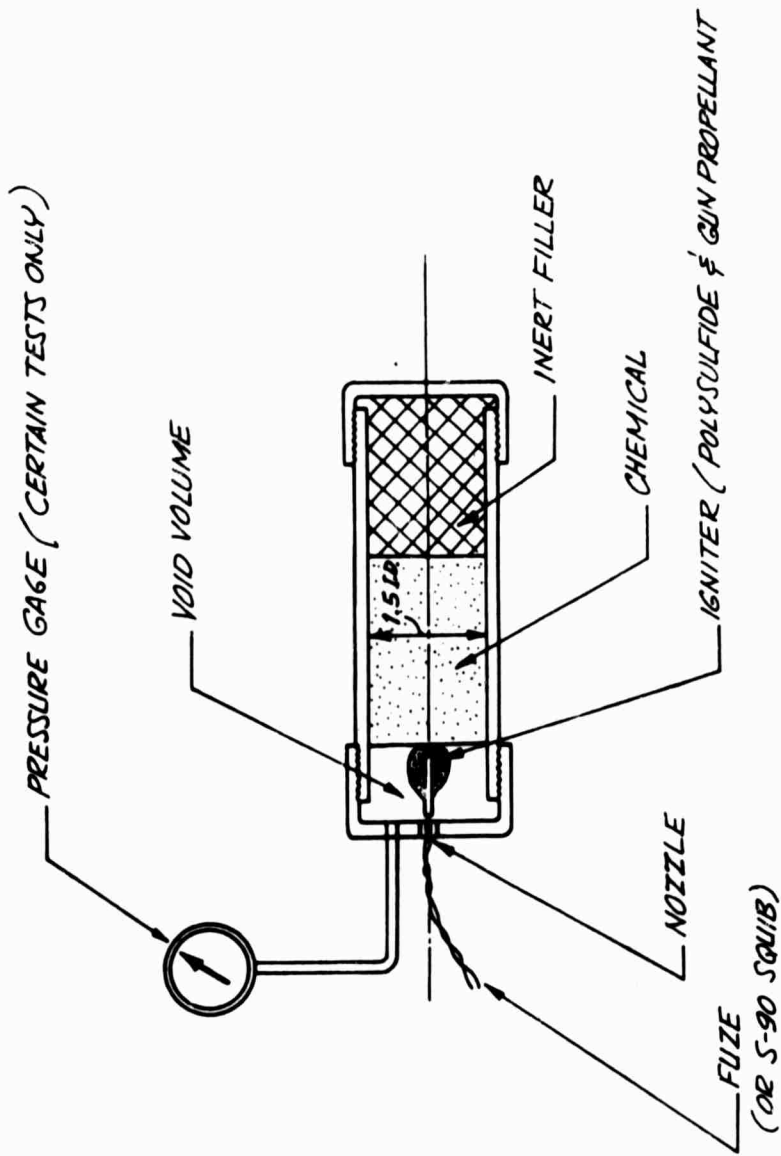

FIGURE 3  
 SMALL SCALE CONFIGURATION

TABLE 3 SMALL SCALE TESTS

| Test No. | Mix No. | Burner Volume Cu. In. | Void Volume Cu. In. | Chem. Wt. Gms. | Loading Pressure psi | Nozzle Dia. In. | Maximum Pressure psi | Burn Time Sec. | Igniter Type | Remarks  |
|----------|---------|-----------------------|---------------------|----------------|----------------------|-----------------|----------------------|----------------|--------------|--|
| 1        | 1       | 9.0                   | 1.7                 | 171            | 9800                 | 0.25            |                      | 70             | A            | Burn incomplete, approx. 1/2 of chemical burned. |
| 2        | 1       | 9.0                   | 1.7                 | 165            | 9800                 | 0.375           |                      | 110            | A            |  |
| 3        | 1       | 9.0                   | 1.7                 | 155            | 9800                 | 0.375           |                      | 90             | A            | Grain was made with 3/8" dia. hole in middle.    |
| 4        | 2       | 9.0                   | 1.7                 | 183            | 9800                 | 0.375           |                      | 17             | A            |  |
| 5        | 2       | 9.0                   | 1.7                 | 429            | 5000                 | 0.375           |                      |                | B            | Detonated  |
| 6        | 2       | 8.1                   | 3.4                 | 228            | 5000                 | 0.250           |                      |                | B            |  |
| 7        | 2       | 6.8                   | 3.4                 | 181            | 9800                 | 0.375           |                      | 18             | C            |  |
| 8        | 2       | 12.4                  | 8.8                 | 448            | 9800                 | 0.375           |                      | 28             | C            |  |
| 9        | 2       | 8.5                   | 5.1                 | 220            | 9800                 | 0.250           |                      | 9              | C            |  |
| 10       | 2       | 8.5                   | 5.1                 | 237            | 9800                 | 0.125           |                      |                | C            | Detonated  |

| Test No. | Mix No. | Burner Volume Cu. In. | Void Volume Cu. In. | Chem. Wt. Grams | Loading Pressure psi | Nozzle Dia. In. | Maximum Pressure psi   | Burn Time Sec. | Igniter Type | Remarks              |
|----------|---------|-----------------------|---------------------|-----------------|----------------------|-----------------|------------------------|----------------|--------------|----------------------|
| 11       | 2       | 11.9                  | 3.4                 | 463             | 9800                 | 0.250           |                        | 19             | C            |                      |
| 12       | 3       | 7.6                   | 3.4                 | 231             | 9800                 | 0.250           |                        | 11             | C            |                      |
| 13       | 2       | 7.6                   | 3.4                 | 225             | 9800                 | 0.250           | 48                     | 10             | C            |                      |
| 14       | 2       | 7.6                   | 3.4                 | 225             | 9800                 | 0.312           | 40                     | 11             | C            | Boron pressure gage. |
| 15       | 2       | 7.6                   | 3.4                 | 221             | 9800                 | 0.375           | 40                     | 11             | C            |                      |
| 16       | 2A      | 7.6                   | 3.4                 | 215             | 9800                 | 0.50            |                        | 31             | D            | No pressure visible  |
| 17       | 2A      | 7.6                   | 3.4                 | 183             | 9800                 | 0.250           |                        |                | C            | No data              |
| 18       | 2A      | 7.6                   | 3.4                 | 202             | 9800                 | 0.375           | 50 - 100               | 16             | D            | Fuse ignited 4" long |
| 19       | 2A      | 7.6                   | 3.4                 | 214             | 9800                 | 0.312           | 60                     | 10.5           | D            | Same as above        |
| 20       | 2A      | 7.6                   | 3.4                 | 201             | 9800                 | 0.250           | 60 & two surges to 200 | 9              | D            | Same as above        |
| 21       | 2A      | 7.6                   | 3.4                 | 223             | 9800                 | 0.125           |                        |                | D            | Detonated            |

| Test No. | Mix No. | Burner Volume Cu. In. | Void Volume Cu. In. | Chem. Wt. Grams | Loading Pressure psi | Nozzle Dia. In.     | Maximum Pressure psi | Burn Time Sec. | Igniter Type | Remarks                                  |
|----------|---------|-----------------------|---------------------|-----------------|----------------------|---------------------|----------------------|----------------|--------------|--|
| 22       | 28      | 7.6                   | 3.4                 | 207             | 9800                 | 0.250               | 20                   | 25             | D            | Fuse ignited                             |
| 23       | 28      | 7.6                   | 3.4                 | 201             | 9800                 | 0.250               | 150 to 20 to 150     | 13             | D            | Fuse ignited                             |
| 24       | 6       | 5.35                  | 1.7                 | 200             |                      | 0.25 <sup>(1)</sup> |                      | 5              | D            |  |
| 25       | 8       | 5.35                  | 1.7                 | 200             |                      | 0.25                |                      | 7              | D            |  |
| 26       | 8       | 5.55                  | 1.7                 | 200             |                      | 0.25                |                      | 7              | D            |  |
| 27       | 9       | 5.35                  | 1.7                 | 200             |                      | 0.25                |                      | 3.5            | D            |  |
| 28       | 9       | 5.35                  | 1.7                 | 200             |                      | 0.25                |                      | 3.3            | D            |  |
| 29       | 10      | 5.35                  | 1.7                 | 200             |                      | 0.25                |                      | 2.4            | D            |  |
| 30       | 11      | 5.35                  | 1.7                 | 200             |                      | 0.25                |                      | 2.05           | D            |  |
| 31       | 3       | 5.35                  | 1.7                 | 200             |                      | 0.25                |                      | 10.0           | D            |  |
| 32       | 3       | 5.35                  | 1.7                 | 200             |                      | 0.36                |                      | 11.8           | D            | Nozzle same area as 2 each 0.25 In. Dia. |
| 33       | 7       | 5.35                  | 1.7                 | 200             |                      | 0.25                |                      | 1.5            | D            |  |
| 34       | 4       | 5.35                  | 1.7                 | 200             |                      | 0.25                |                      | 1.5            | D            |  |
| 35       | 6       | 5.35                  | 1.7                 | 200             |                      | 0.25                |                      | 5.0            | D            |  |

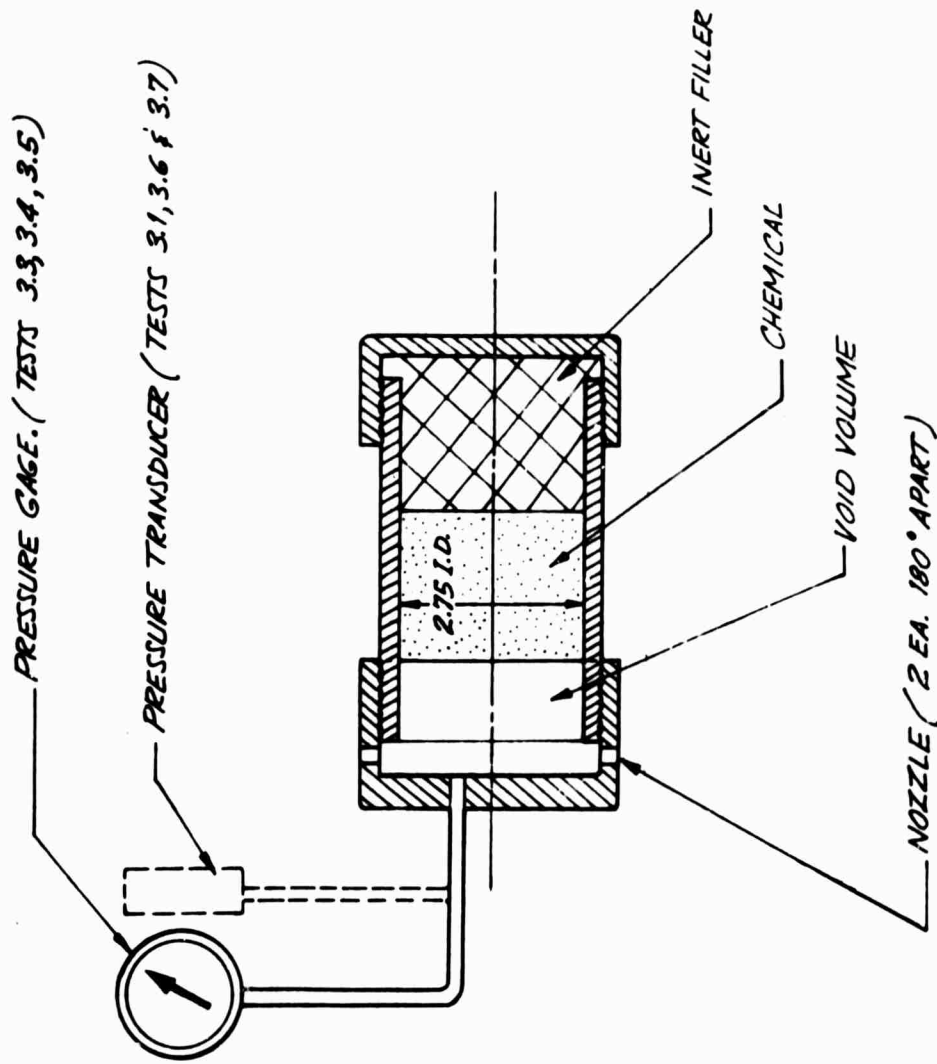

FIGURE 4  
FULL I.D. SHORT CONFIGURATION

TABLE 4

## FULL I.D. SHORT CONFIGURATION TEST SUMMARY

| Test No. | Mix No.                        | Burner Volume Cu. In. | Void Volume Cu. In. | Chem. Wt. Grams | Loading Pressure psi | Nozzle Dia. In.  | Maximum Pressure psi | Burn Time Sec. | Igniter Type | Remarks  |
|----------|--------------------------------|-----------------------|---------------------|-----------------|----------------------|------------------|----------------------|----------------|--------------|--|
| 1        | 2 + 10% B/<br>KNO <sub>3</sub> | 14.7                  | 8.4                 | 321             | 10,000               | 0.250(1)         | G5, steady state     | 1              | D            | Osc. trace taken of pressure 200 psi ignition spike, Det., 1 sec, lid blew off |
| 2        | 3                              | 14.7                  | 8.4                 | 315             | 10,000               | 0.250            |                      | 6              | D            | No inst. taken Applied cloth tape liner to chem. chamber                       |
| 3        | 3                              | 25.0                  | 11.5                | 630             | 10,000               | 0.250            |                      | 10             | D            | Pressure gauge fitting burned through. Cloth tape liner used.                  |
| 4        | 3                              | 25.0                  | 11.5                | 630             | 10,000               | 0.250            | 60                   | 10             | D            | Visual pressure used. Cloth tape liner.  |
| 5        | 3                              | 25.0                  | 11.5                | 630             | 10,000               | 0.250 Opp Horiz. | 70                   | 10             | D            | Same as above  |
| 6        | 3                              | 25.0                  | 11.5                | 630             | 10,000               | Same as above    | 80, initial 60       | 9.2            | D            | Osc. record taken Cloth tape liner used.                                       |
| 7        | 3                              | 25.0                  | 11.5                | 630             | 10,000               | Same as above    | 106 initial 61       | 9.2            | D            | Same as above  |

NOTE: Device Type - 2.88" I.D. pipe used for all tests

NOTES FOR TABLES 3 AND 4

- (1) Igniter = C type S-90 squib and 5 grams polysulfide
- (2) I.D. Burner = 1.5 inches
- (3) Nozzle, 1 each steel
- (4) Forming Pressure = 10,000 pounds
- (5) I.D. = 1.5 inches
- (6) Igniter Type

A = 5 grams Polysulfide

B = S-90, 1 gram Polysulfide,

1 gram Boron Potassium Nitrate

D = S-90, 5 grams Polysulfide

D = Pyro fuze and 2.5 grams Polysulfide

2.5 grams gun propellant

- (7) Plus 10% Boron Potassium Nitrate

TABLE 5

## FULL SCALE TESTS

| Unit No.  | Mix No. | Net Chem. Wt. (Lb) | Length Change In. | Dia. Change In. | Ignition Pres. psi  | Burn Time Sec. | Burn Pres. Initial psi | Nozzle Dia. 2 Each In. | Remarks                    |
|-----------|---------|--------------------|-------------------|-----------------|---------------------|----------------|------------------------|------------------------|----------------------------|
| 362-10-1  | 3       | 6.50               | 9.562             | 2.625           | 300                 | 17             | 75                     | 0.250                  | Burn through at 17 seconds |
| 362-10-2  | 3       | 6.49               | 9.562             | 2.600           | N.R. <sup>(1)</sup> | 23             | -                      | 0.250                  | Burn through at 23 seconds |
| 362-10-3  | 3       | 5.60               | 9.810             | 2.500           | N.R.                | 28             | -                      | 0.250                  | O.K.                       |
| 362-10-4  |         | 5.274              | 10.25             | 2.428           | 208                 | 35             | 60                     | 0.250                  | O.K. Fired in vacuum       |
| 362-10-11 | 3       | 5.25               | N.R.              | 2.428           | N.R.                | 18             | N.R.                   | 0.250                  | Vertical burn through      |
| 362-10-18 | 11      | 5.000              | 9.75              | 2.428           | N.R.                | 12             | N.R.                   | 0.250                  | O.K.                       |
| 362-10-19 | 6       | 5.9                | 10.1              | 2.428           | N.R.                | 17.8           | N.R.                   | 0.250                  | O.K.                       |
| 362-10-20 | 3       | 5.50               | N.R.              | 2.428           | N.R.                | 38             | N.R.                   | 0.219                  | Burn through at 38 seconds |

NOTES: (1) Not Recorded

- 362-10-1 No steel sleeve or insulation  
 362-10-2 3 layers of .010 grafoil .030 thick I.D. of can  
 362-10-3 .080 thick steel liner and 0.060 thick asbestos liner between steel liner and can - bonded with thermax liner  
 362-10-4 .110 thick steel liner and .060 thick asbestos liner between steel liner and can

Ground Test Summary - Series 4

TABLE 6 FLIGHT TEST SUMMARY

| Launch Date 1968 | Mix No. | Serial Number | Net Chem. Wt. (lb) | Length of Charge In. | Nozzle <sup>(1)</sup> Dia. In. | Gross <sup>(2)</sup> Wt. (Lb) | Peak Alt. K-ft | Impact Range K-ft | Ignition Time (sec) | Burn Time Sec.   | Remarks     |
|------------------|---------|---------------|--------------------|----------------------|--------------------------------|-------------------------------|----------------|-------------------|---------------------|------------------|-------------|
| 3/8              | 3       | 362-10-5 6    | 5.45               | 10.25 <sup>(6)</sup> | 0.250                          | 3.95                          | 28             | 15.8              | 30                  | 35               |             |
| 3/8              | 3       | 362-10-6 4    | 5.45               | 10.56                | 0.250                          | 33.9                          | 30             | 16.4              | 28                  | 40               |             |
| 3/7              | 3       | 362-10-7 1    | 5.44               | 10.56                | 0.250                          | 33.9                          | 22             | 13.4              | 30                  | (4)              |             |
| 3/8              | 3       | 362-10-8 5    | 5.67               | 10.56                | 0.1875                         | 49.5                          | 27             | 16.0              | (4)                 | (4)              | No Ignition |
| 3/7              | 3       | 362-10-9 2    | 5.68               | 10.595               | 0.250                          | 49.5                          | 26.5           | 15.8              | (4)                 | (4)              |             |
| 3/8              | 3       | 362-10-10 3   | 5.59               | 10.405               | 0.250                          | 49.5                          | 27             | 14.6              | (4)                 | (4)              |             |
| 3/27             | 11      | 362-10-23 9   | 5.5                | 19.125               | 0.250                          | 73.0                          | 25.6           | 2.85              | 16                  | 9                |             |
| 3/27             | 11      | 362-10-24 10  | 5.5                | 10.375               | 0.250                          | 73.0                          | 25.6           | 2.36              | 13                  | 8                |             |
| 3/28             | 11      | 362-10-25 11  | 5.5                | 10.125               | 0.250                          | 74.0                          |                | 3.28              | 26                  | 4 <sup>(3)</sup> |             |
| 3/27             | 3       | 362-10-26 7   | 3.5                | 10.125               | 0.250                          | 72.0                          | 26.8           | 2.1               | 17                  | 23               |             |
| 3/27             | 3       | 362-10-27 8   | 3.5                | 10.000               | 0.250                          | 72.75                         | 26.6           | 2.4               | 18                  | 23               |             |
| 3/28             | ?       | 362-10-28 12  | 3.5                | 9.750                | 0.25073.0                      | 73.0                          | 26.5           |                   | (5)                 | (5)              |             |

NOTES:

- (1) Aligned riding lugs 45° between fins, aligned igniter lead with lug (Helix 17-1/2° per/foot right looking forward) (Body weight with 5/8 screw = 10 pounds)
- (2) Payload = 36 inches long, 3 inches O. D., 362-25 nose
- (3) Launch Q.E. = 80°
- (4) Not visually observed
- (5) Not ignited purposely
- (6) Charge diameter = 2.375

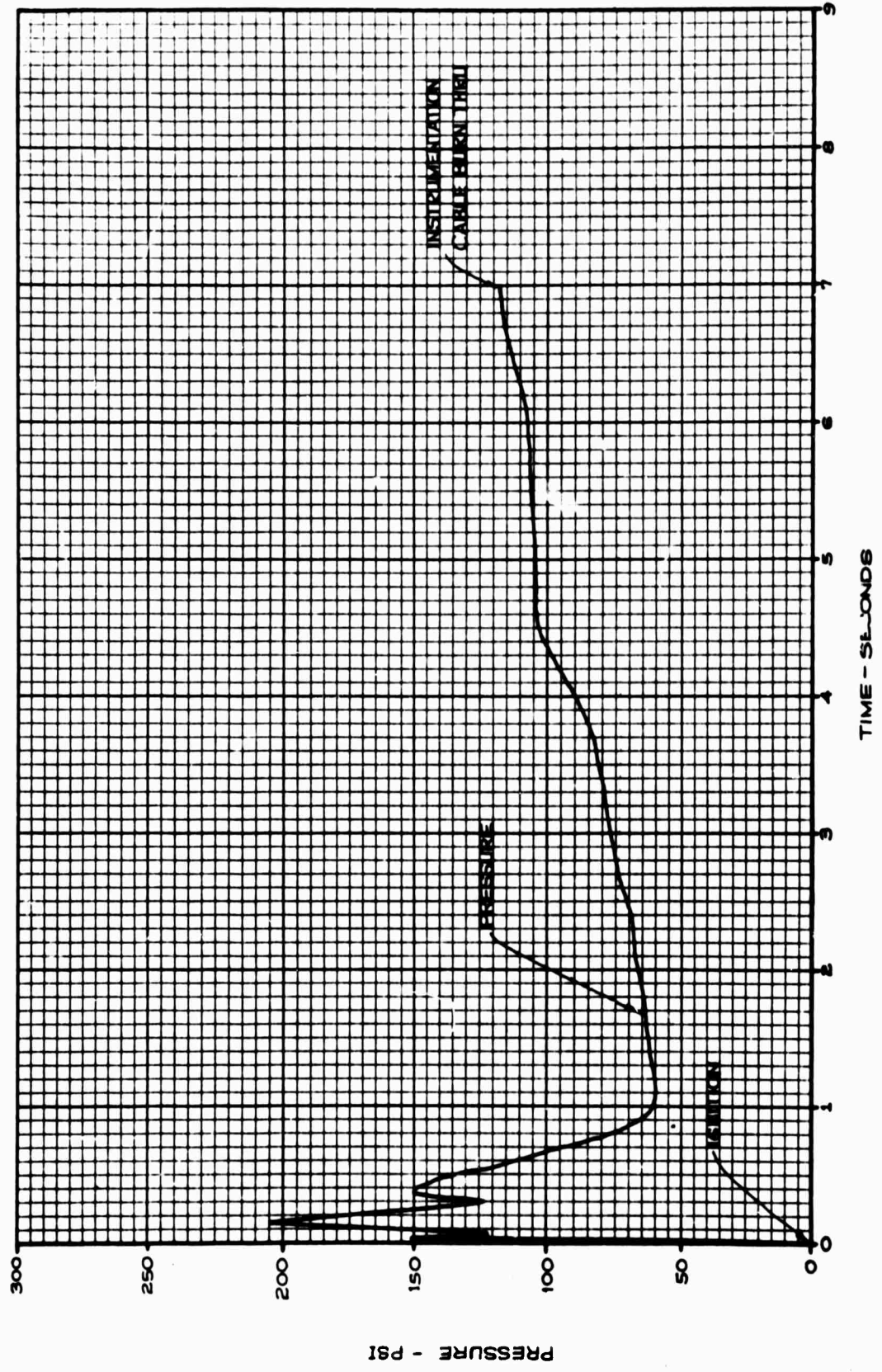

FIGURE 5 PRESSURE-TIME RECORD TEST 362-10-4

## 2.6 Conclusions.

The technical requirements of this program were satisfied. The following conclusions were made from the ground test results.

- a. Mix number three and eleven perform in a satisfactory manner and therefore, were used in the flight payload.
- b. A satisfactory igniter material was selected consisting of 50% polysulphide and 50% Navy gun propellant.
- c. Paraffin cannot be used in the mix due to the vaporization gases produced from the wax causing overpressures. A total of four detonations occurred while using a 2% wax in the mix.
- d. The addition of boron potassium nitrate to the chemical mix did not demonstrate an increase in steady state burning pressure or burning rate.
- e. The initial void volume affects only the ignition pressure. The steady state burning pressure is unaffected by initial volume.

DOCUMENT CONTROL DATA - R & D

(Security classification of title, body of abstract and indexing annotation must be entered when the overall report is classified)

|   |                                     |   |  |
|---|-------------------------------------|---|--|
| 1. ORIGINATING ACTIVITY (Corporate author)<br><b>Space Data Corporation<br/>1331 South 26th Street<br/>Phoenix, Arizona</b>   |                                     | 2a. REPORT SECURITY CLASSIFICATION<br><b>Unclassified</b>   |  |
|   |                                     | 2b. GROUP   |  |
| 3. REPORT TITLE<br><b>DESIGN, DEVELOPMENT AND FLIGHT TEST OF CHEMICAL RELEASE PAYLOADS FOR UPPER ATMOSPHERE RESEARCH</b>  |                                     |   |  |
| 4. DESCRIPTIVE NOTES (Type of report and inclusive dates)<br><b>Scientific Final. 1 July 1965 - 31 August 1968 Approved 21 November 1968</b>  |                                     |   |  |
| 5. AUTHOR(S) (First name, middle initial, last name)<br><b>Edward F. Allen, Jr.</b>   |                                     |   |  |
| 6. REPORT DATE<br><b>30 September 1968</b>  | 7a. TOTAL NO OF PAGES<br><b>246</b> | 7b. NO OF REFS<br><b>9</b>  |  |
| 8a. CONTRACT OR GRANT NO<br><b>AF19(628)-5125 ARPA Order 1141</b>   |                                     | 9a. ORIGINATOR'S REPORT NUMBER(S)<br><b>SDC TM-328</b>  |  |
| b. PROJECT, TASK, AND WORK UNIT NO.<br><b>7635,000D, 8688 - 08,49,75 - 01</b>   |                                     | 9b. OTHER REPORT NO(S) (Any other numbers that may be assigned this report)<br><b>AFCL-68-0587</b>  |  |
| c. DOD ELEMENT<br><b>62405394, 61430014, 6250301D</b>   |                                     |   |  |
| d. DDD SUBELEMENT<br><b>681000, 680100</b>  |                                     |   |  |
| 10. DISTRIBUTION STATEMENT<br><b>Distribution of this document is unlimited. It may be released to the Clearinghouse, Department of Commerce, for sale to the general public.</b>   |                                     |   |  |
| 11. SUPPLEMENTARY NOTES<br><b>This research was partially supported by the Air Force In-House Laboratory Independent Research Fund; also in part by the Advanced Research Projects Agency.</b>  |                                     | 12. SPONSORING MILITARY ACTIVITY<br><b>Air Force Cambridge Research Laboratories (CRA)<br/>L. G. Hanscom Field<br/>Bedford, Massachusetts 01730</b> |  |
| 13. ABSTRACT<br><br><b>Rocket borne chemical payload systems were designed, developed and flight tested to give controlled releases of gases, liquids and solids. Payloads consisted of chemical tanks, chemicals, fluid controls with associated plumbing, event programmer and aerodynamic envelope.</b><br><br><b>Trimethylaluminum, Diborane, Nitric Oxide, High Explosives seeded with metals, Barium/Copper Oxide and Cesium Nitrate/Aluminum/Tungsten systems were provided.</b><br><br><b>Chemical handling techniques were developed and engineering field services were provided to assist with payload launches.</b> |                                     |   |  |

| 14<br>KEY WORDS                           | LINK A |    | LINK B |    | LINK C |    |
|---|--------|----|--------|----|--------|----|
|   | ROLE   | WT | ROLE   | WT | ROLE   | WT |
| Payload, Chemical                         |        |    |        |    |        |    |
| Payload, Rocket                           |        |    |        |    |        |    |
| Payload, Nitric Oxide                     |        |    |        |    |        |    |
| Payload, Trimethylaluminum                |        |    |        |    |        |    |
| Payload, High Explosive                   |        |    |        |    |        |    |
| Payload, Diborane                         |        |    |        |    |        |    |
| Payload, Barium                           |        |    |        |    |        |    |
| Payload, Cesium Nitrate/Aluminum/Tungsten |        |    |        |    |        |    |
| Payload, Development                      |        |    |        |    |        |    |



FA 481 853

ERRATA

FINAL REPORT AF 19(628)-5125  
DESIGN, DEVELOPMENT AND FLIGHT TESTS OF  
CHEMICAL RELEASE PAYLOADS FOR  
UPPER ATMOSPHERE RESEARCH

PREPARED FOR  
AIR FORCE CAMBRIDGE RESEARCH LABORATORIES  
L. G. HANSCOM FIELD  
BEDFORD, MASSACHUSETTS 01730

Correction: In Block 3 of the DD Form 1473, the word should be TESTS.