

AD 682867

85

①

TRANSLATION NO. 368

DATE: March 1958

DDC AVAILABILITY NOTICE

~~This document is subject to special export controls and each transmittal to foreign persons or foreign nationals must be made with prior approval of the Office, Fort Detrick, ATTC AFSD-AE-T, Frederick, Md. 21701.~~

MAR 4 1958

*df*

DEPARTMENT OF THE ARMY  
Fort Detrick  
Frederick, Maryland  
Reproduced by the  
**CLEARINGHOUSE**  
for Federal Scientific & Technical  
Information Springfield Va. 22151

Translated from Dok. Akad. Nauk SSSR, 94 (1954), 3, 467-470.

### THE COAGULATION OF CHARGED CLOUD-DROPLETS

L. M. Levin

(Presented by O. Yu. Shmidt,  
Member of the Academy, November 26, 1956.)

According to present theory of the formation of precipitations [1, 2], the growth of cloud-droplets in the range of diameters  $d = 4 \sim 30 \mu$  takes place only by way of condensation of water vapor. The basis of this conclusion is that since there exists a critical value  $k_{cr} = 1.214$  [2, 3] for the parameter of gravitational coagulation, then coagulation of neutral droplets is possible only when the diameter of the larger drop exceeds  $30 \mu$ . But, it seems to us that growth of cloud-droplets in the range  $d = 4 \sim 30 \mu$  may take place through coagulation of electrically charged droplets. To confirm this hypothesis, let us calculate E, the coefficient of capture [3], for electrically charged droplets.

Langmuir [2] and Shishkin [1] unjustifiably applied the theory of deposition of an aerosol on obstacles to the theory of cloud-droplet growth. The coefficient of capture, in the deposition of an aerosol on a sphere, was calculated [2] under the assumption that the sphere is considerably larger than the aerosol particle. Consequently these calculations may be applied to the descent of droplets of raindrop size in a cloud, but not to the case of two droplets of comparable size. Langmuir, in calculating the growth of cloud-droplets, really considers all the cloud-droplets to be fixed in space, except one droplet (sometimes of the same dimensions as the others) which moves under the influence of gravitation and of rising air currents [2]. Shishkin, however, takes the coagulation of droplets as depending only on their relative velocity [1], although it is easy to see that the air velocity fields around the droplets, which determine the droplet interaction, depend on the velocities of the droplets relative to the air. Since it is not at present possible to account for the interaction of the aerodynamic fields of two droplets, it seems reasonable to us to perform the calculations for cases when one of the drops is considerably smaller than the other, and in doing so to take the aerodynamic field of the small droplet as not affecting the field of the large droplet. Then in a coordinate system tied to the large droplet, the small droplet will be acted upon by the force of gravity, by the electric forces, and by the aerodynamic Stokes force.

\* For instance, with a rising air velocity of 10 cm/sec, the droplet diameter grows by condensation from 11 to  $30 \mu$  in 7.5 hours, and then grows by gravitational coagulation to  $1300 \mu$  in 15-20 minutes [1].

AD 682867

1) In the case of both droplets' bearing electric charges of different signs, the equation of motion of the small droplet will take the form

$$\frac{\pi d^3}{6} \rho_k \frac{d v_1(r_1)}{dt} = -3\pi \mu d [u_1(r_1) - v_1(r_1)] + \frac{e_1 e_2}{r_1^2} r_1 + \frac{\pi d^3}{6} \rho_k g, \quad (1)$$

where  $r_1$  is the radius vector to the center of the small droplet,  $v_1 = dr_1/dt$  is its velocity vector,  $d$  is the droplet diameter,  $\rho_k$  its density,  $e_1, e_2$  the charges on the droplets;  $u_1(r_1)$  is the field of velocities of the air stream around the large droplet,  $\mu$  is the viscosity coefficient of the air, and  $g$  is the vector acceleration of gravity.

Converting equation (1) to the dimensionless form [3] (as characteristic velocity we take the constant descent velocity of the large droplet,  $u_\infty = \rho_k g D^2 / 18 \mu$ , and as characteristic size  $D/2$ ), we find \*

$$k \frac{dv}{dt} + v = u + k \sigma_1 \frac{r}{r^2} + g_1, \quad (2)$$

where

$$k = \frac{d^3 \rho_k u_\infty}{9 \mu D}; \quad \sigma_1 = \frac{12 e_1 e_2}{\pi d^3 D u_\infty^2 \rho_k} < 0; \quad g_1 = \frac{g D}{2 u_\infty^2} k = \frac{d^2}{D^2}$$

are dimensionless scaling criteria for the phenomena.

It is obvious that for  $|\sigma_1| \gg 1$  we may neglect the inertia term in equation (2), whereupon this equation takes the form (for  $\alpha = -k\sigma_1 > 0$ ):

$$v = u - \alpha \frac{r}{r^2} + g_1. \quad (3)$$

Examination of equation (3) shows that for small values of  $\alpha$  it has seven singular points (four saddles on the  $\rho$  axis, two centers and a dipole at the coordinate origin), and for large values of  $\alpha$ , three singular points (two saddles on the  $\rho$  axis and a dipole). Figure 1 illustrates the topological configurations of the trajectories of equation (3) for different values of  $\alpha$ . This figure shows that the separatrices A passing through a saddle ( $\rho = 0, x > 1$ ) represent limiting trajectories determining the capture coefficient E. This means we have  $E = \rho_0^2$  ( $\rho_0$  being the distance of the said separatrix from the  $\rho$  axis at  $x \rightarrow -\infty$ ), since, as we shall show infra, these separatrices do not intersect the surface of the large droplet.

On the other hand, we can derive expressions for the trajectories described by equation (3) in finite form, if we note that the field corresponds to a Stokes stream having, in dimensionless (spherical) coordinates, the stream function  $\psi(r, \theta) = \frac{\sin^3 \theta}{2} (r^2 - \frac{3}{2} r + \frac{1}{2r})$ . Then for the trajectories we get

$$\frac{dr}{r d\theta} = \frac{v_r}{v_\theta} = \frac{u_r - \alpha/r^2 + g_{1,r}}{u_\theta + g_{1,\theta}} = \frac{\frac{1}{r^2} \frac{\partial \psi}{\partial \theta} - \frac{\alpha}{r^2} - g_1 \cos \theta}{-\frac{1}{r \sin \theta} \frac{\partial \psi}{\partial r} + g_1 \sin \theta}, \quad (4)$$

\* In equation (2) we have the dimensionless quantities  $v = v_1/u_\infty$ ,  $u = u_1/u_\infty$ ,  $r = 2r_1/D$ ,  $\tau = 2t u_\infty/D$  where  $D$  is the diameter of the large droplet.

of  
take

(1)

$v_1 = dr_1/dt$   
,  $e_1, e_2$   
the air  
the air,

haracteristic  
t,

(2)

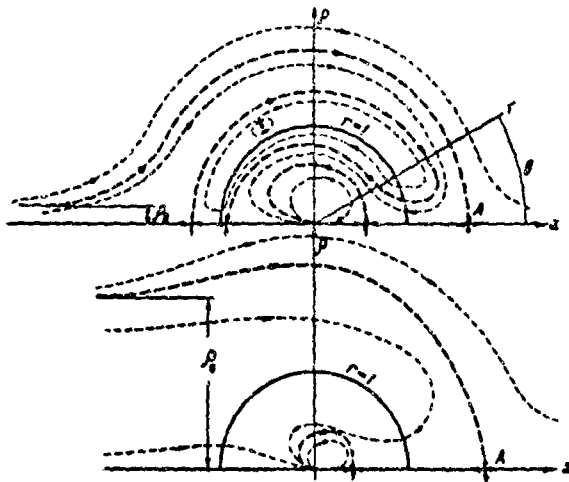

Fig. 1

term in  
> 0):

(3)

it has  
dipole  
points  
topo-  
rent  
ugh a  
capture  
he said  
these

ies

ordinates,

as we get

4)

$u_{\infty}$ .

and consequently,

$$d\psi_1 = d\left(\psi - g_1 \frac{r^2 \sin^2 \theta}{2}\right) = \alpha \sin \theta d\theta. \quad (5)$$

From this it is easy to find the equation of the trajectories:

$$\psi_1 = \psi_{1,\pi} - \alpha(1 + \cos \theta), \quad (6)$$

where  $\psi_{1,\pi}$  is the value of  $\psi_1$  for the trajectory at  $\theta = \pi$ .

Noting that the separatrix we are seeking has, at  $\theta = 0$ , a finite value of  $r$ , we find for it the value of  $\psi_{1,\pi}$ , equal to  $\psi_{1,\pi} = \frac{\rho_1^2(1-g_1)}{2} = 2\alpha$ . Since according to equation (5) we have  $d\psi_1/d\theta > 0$  along the trajectory, then the separatrix in question, having  $\psi_1 = 0$  at  $\theta = 0$ , nowhere intersects the surface of the large droplet, for which  $\psi_1 < 0$ . Consequently,

$$E = \rho_1^2 = \frac{4\alpha}{1-g_1}. \quad (7)$$

- oOo -

2) Let us now consider that case when the large droplet is charged and the small droplets neutral. Then in the first approximation the charge of the large droplet will induce dipoles in the small droplets and attract them. The equation of motion of the small droplets, in the same coordinate system, takes the form (ref. [4]):

$$\frac{d\pi^2}{6} \rho_1 \frac{dv_1(r_1)}{dt} = -3\pi_1 d |u_1(r_1) - v_1(r_1)| - \frac{1}{4} \frac{\epsilon-1}{\epsilon+2} d^3 \frac{\epsilon_1}{r^3} r_1 + \frac{\pi d^3}{6} \rho_1 g. \quad (8)$$

where  $\epsilon$  is the small droplet dielectric constant.

In dimensionless form equation (8) becomes:

$$k \frac{dv}{d\tau} + v = u - k\sigma_2 \frac{r}{r^2} + g_1, \quad (9)$$

where  $\sigma_2 = \frac{2k}{\pi} \frac{\epsilon-1}{\epsilon+2} \frac{r_1^2}{\rho_1 D^2 u_1^2} > 0$ .

If  $\sigma_2 \gg 1$ , then equation (9) is simplified:

$$v = u - k\sigma_2 \frac{r}{r^2} + g_1, \quad (10)$$

and the trajectories of motion may be determined from an equation similar to (5):

$$d\psi_1 = \frac{\alpha \sigma_2 \sin \theta d\theta}{r^2}. \quad (11)$$

Equation (10) has eight singular points. Their positions and the topological configurations of the trajectories are similar to the cases illustrated in Figure 1.\*

- 000 -

3) Tables 1 and 2 present the results of our calculations of E; likewise values of  $\sigma_1$  and  $\sigma_2$ , enabling one to estimate the applicability of the computation methods as developed (the calculations were carried out for  $\sigma_1, \sigma_2 > 5$  and  $g_1 \leq 0.25$ ). The order of magnitude of the charge was calculated according to Ya. I. Frenkel' [5], and for the absolute magnitude of the charge in the CGSE system we accepted the expression

$$e = 0.5 \cdot 10^{-7} d [\mu], \quad (12)$$

corresponding to a value of 0.3 V for the electrokinetic potential. It seems to us that the magnitude of the charge accepted by us according to expression (12) has been selected reasonably as regards order of magnitude, and does not contradict the experimental findings of Gunn [6], who measured the gross charge of cloud-droplets of diameter  $d > 10 \mu$ .

TABLE 1

D [μ]	d [μ]	$\sigma_1$	E	D [μ]	d [μ]	$\sigma_1$	E
5	1	15600	65,2	15	6	5,4	2,8
5	2	3900	71,7	20	1	61	0,98
7,5	1	3080	18,8	20	3	6,8	1,00
7,5	4	100	25,9	25	1	25	0,50
10	1	9	7,9	25	2	6,2	0,50
10	5	39	10,4	30	1	12	0,29
15	1	192	2,3	30	1,5	5,4	0,29

TABLE 2

D [μ]	$\sigma_1$	E		
		$g_1 = 0,25$	$g_1 = 0,1$	$g_1 = 0,04$
5	1250	2,32	1,48	0,89
7,5	110	1,06	0,69	0,40
10	20	0,57	0,38	0,22
12,5	5,1	0,34	0,23	0,13

\* The difference amounts to the fact that the dipole reduces to two nodes, a stable node, at the coordinate origin, and an unstable node ( $\rho = 0, 0 < x < 1$ ), while the centers are converted into unstable foci or unstable nodes. As previously, the separatrix A passing through a saddle ( $\rho = 0, x > 1$ ) does not intersect the surface of the large droplet (equation (11)) and constitutes a limit trajectory. Numerical calculations have shown that equation (11) is convenient for constructing this separatrix (calculation of E).

Tables 1 and 2 show that under these assumptions the coefficient of capture for cloud-droplets, in the range with which we are dealing, is high enough to guarantee a considerable coagulation of droplets, while for neutral droplets of the same sizes there is no coagulation. The amount of coagulation will be rather great even if the actual size of the charges is an order of magnitude lower than that which we have taken.

- oOo -

4) From the expressions for  $\sigma_1$  and  $\sigma_2$  it follows that at large values of  $D$  (when  $u_\infty$  also is large) the quantities  $\sigma_1, \sigma_2 \ll 1$  and, consequently, the effect of the electric charges on coagulation may be neglected. This accounts for the experimental results of Gunn and Hiltchfeld [7], in which  $D = 3.2$  mm,  $d > 5 \mu$  and  $e_1 = 0.2$  CGSE. Thus in these experiments  $u_\infty = 825$  cm/sec and  $\sigma_1 = 4 \cdot 10^{-5}$ ,  $\sigma_2 < 7 \cdot 10^{-3}$ . Consequently these authors did not find any electric charge effect on the coagulation of a large droplet with small droplets.

In the same way, by calculating the quantities  $\sigma_1$  and  $\sigma_2$  it may be shown that in cloud-droplet catchers the precipitation of droplets onto the receiver is in practice independent of the electric charges of the droplets and of the droplet receiver.

Similar results are indeed found for charged droplets.

In conclusion I express my cordial thanks to V. M. Bovsheverov for fruitful discussion of the results of this work.

Geophysical Institute,  
Academy of Sciences of the USSR.

Received October 21, 1953.

#### REFERENCES

- 1) N.S. SHISHKIN, Usp. Fiz. Nauk [Progress of the Physical Sciences], 45, 3, 313 (1951).
- 2) I. Langmuir, J. Meteor., 5, 175 (1948).
- 3) L.M. LEVIN, Dok. Akad. Nauk, 91, No. 6 (1952).
- 4) R. Cochet, Ann. de Géophys., 8, 33 (1952).
- 5) Ya. I. FRENKEL', Teoriya yavlenii atmosfernogo elektrichestva [Theory of atmospheric electric phenomena], 1943.
- 6) R. Gunn, J. Meteor., 9, 397 (1952).
- 7) K. Gunn, W. Hiltchfeld, ibid., 8, 7 (1951).