

AD 682909

TRANSLATION NO. 652

DATE: 21 Sept 1949

(1)

DDC AVAILABILITY NOTICE

This document is subject to special export control and can be transmitted to foreign governments or foreign national organizations only with prior approval of the commanding Officer, Fort Detrick, Army Signal Center, Frederick, Md. 21701.

MAR 6 1950

*[Handwritten signature]*

DEPARTMENT OF THE ARMY  
Fort Detrick  
Frederick, Maryland

Reprinted by the  
CLEARINGHOUSE  
for Federal Security Service  
Information from the Library of Congress

11

THE INFLUENCE OF FOREIGN VAPORS ON THE COAGULATION  
OF AEROSOLS

I. S. ARTEMOV.

A number of works by different authors have brought us to a good approximation of an understanding of the processes which take place in aerosols under straightforward conditions, when these processes are taking place in pure air.

If vapors of foreign substances are present in the air, complications are introduced into the processes taking place in the aerosols, complications which so far have not been studied, in spite of the practical and theoretical importance of the matter.

The following authors have dealt with the question of the influence of foreign vapors on aerosols: E. I. RUMIANTSEVA (1), who investigated the influence of various vapors on ammonium chloride aerosol; S. S. URAZOVSKI and S. N. KUZMENKO (2), who investigated the influence of various vapors on magnesium oxide and ammonium chloride aerosols; K. N. SAMOKHVALOV and O. S. KOZHUKOVA (3), who investigated the influence of various vapors on mercurous iodide and ammonium chloride aerosols; V. I. SAICHUK and O. G. NARSIKH (4), who investigated the influence of various oil vapors on aqueous fog; N. N. ANDREYEV and S. G. KIBIRASHITIS (5), who investigated the influence of various vapors on ammonium chloride aerosols; A. V. SMIRNOV and V. A. SOLNTSEVA (6), who investigated the influence of various vapors on ammonium chloride aerosols and oil-fog; L. V. RADUSHKEVICH and O. K. CHUGUNOVA (7), who repeated some of the experiments with ammonium chloride; I. V. PETRIANOV, M. V. TIKHOMIROV and N. N. TUNITSKI (8), who carried out preliminary tests with phenol vapors and  $Fe_2O_3$  aerosols.

Material available on the subject is limited to the researches here enumerated, and the results obtained by the different authors are in sharp contradiction one with the other.

For a rapid survey of the contradictions which exist, we give, in fig. 1, the results of the work with ammonium chloride aerosol. In the rectangle we list the vapors to the action of which the aerosol was exposed; the lines and circles with initials indicate the results obtained by the different authors in their experiments.

The existence of contradictions may be explained by the fact that with nearly all these authors the method of producing the aerosols was unsatisfactory (high concentration of aerosol, and the aerosols produced in the presence of 'previously prepared' vapors of the foreign substances). The same may be said of the methods of recording the changes which took place (sedimentation observations). Some of the authors permitted errors to be introduced by secondary mixing of the aerosol with the vapor in small vessels (7). In some cases (4) obvious mistakes were also made in the method of producing the foreign vapor (production of vapor by evaporating the substance in a chamber over a heated metallic surface).

The lack of fundamental research on the influence of foreign vapors on the processes taking place in aerosols motivated us to undertake the present work.

AD 682909

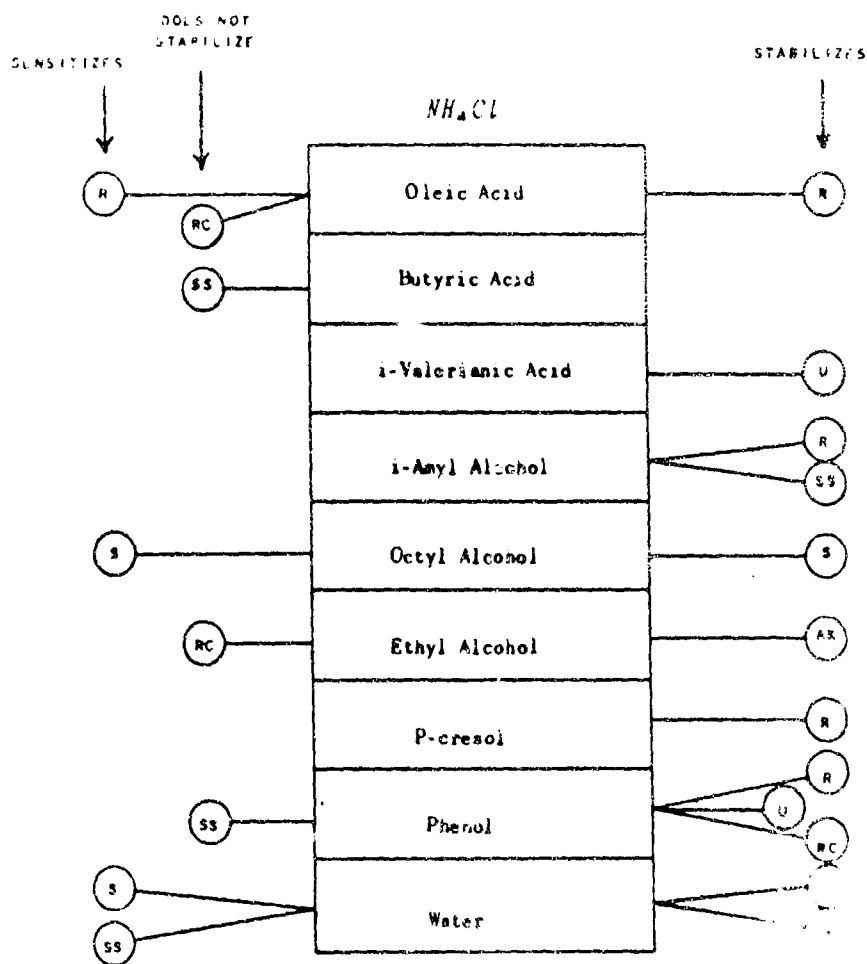

Fig. 1. Diagram of results obtained by previous authors in various researches on aerosol stabilization.

R = RUMIANTSEVA, U = URAZOVSKI and KUZMINEV  
 S = SAMOKHVALOV and KOZLOKHINA  
 AK = ANDRIYEV and KIBIRKSHETS  
 RC = RADUSHKEVICH and CHUGUNOVA  
 SS = SMIRNOV and SOLNTSEVA

...the influence of various foreign vapors on the process of aerosol coagulation, it was necessary to establish conditions such that to all practical intents and purposes no processes other than coagulation took place in the presence of the vapors. We approximated this essential condition by seeing to it:

#### EXPERIMENTAL SET-UP

To ascertain the influence of various foreign vapors on the process of aerosol coagulation, it was necessary to establish conditions such that to all practical intents and purposes no processes other than coagulation took place in the presence of the vapors. We approximated this essential condition by seeing to it:

- 1) That the formation of the aerosols took place in pure air, thus excluding the possibility of the vapor affecting the process of aerosol-formation.
- 2) That no process of sedimentation of the aerosol was going on at the time when results were being observed; this condition was met by having a small initial concentration of the aerosol, and by volatilizing the foreign substance in a stream of air (9).

To check that there was no aerosol sedimentation going on during the time when observations were being made, we used a Nernst-type micro-balance with a sensitivity of  $10^{-6}g$ , which showed no deflection during the period of the observations)

- 3) That the means of producing the aerosols was such as to secure results which could be exactly duplicated.
- 4) That the method selected for introducing the foreign vapors into the chamber, namely that of blowing vapor off the surface of a liquid into a closed vessel, excluded all chances of distorting our results through condensation of the vapor itself, and that it made it possible to introduce with sufficient exactitude the requisite quantity of vapor into the chamber and to distribute it uniformly throughout the volume of the chamber.
- 5) That the aerosol was subjected to mixing only once, in a large chamber, this gave the aerosol less chance of settling on the walls of the chamber.

As it was discovered (page 5) that water vapor had no effect on the coagulation of the aerosols investigated, we did not undertake to dry the air in the chamber for these experiments.

All the tests were carried out in a special hermetically sealing glass smoke-chamber one  $m^3$  in size. The chamber was mounted on a metal frame and was fitted with a fan and exhaust pipe.

As smoke-producing substances we used:-

- 1) Mineral oil (a fraction boiling at  $200-210^{\circ}C$  at a pressure of 4 mm)
- 2) Stearic acid (chemically pure)
- 3) Refined paraffin (melting point  $50^{\circ}C$ , density 0.9).

In all cases we produced the aerosols by thermal condensation before feeding into the chamber.

*Oil fog was produced in the apparatus shown in fig. 2.*

*The electrically heated metal oven A was joined to the tee B with an asbestos pipe. The tee held a metal pipe 40 cm long and 3 cm in diameter, which was shielded from heat by the screen C and cooled with a stream of cold water.*

*Oven A was equipped with three metal pipes C, D, E. In C there was mounted, on an adjustable axis with a subsequent setting of sodium sulphate, a thermometer with a scale up to  $300^{\circ}C$ .*

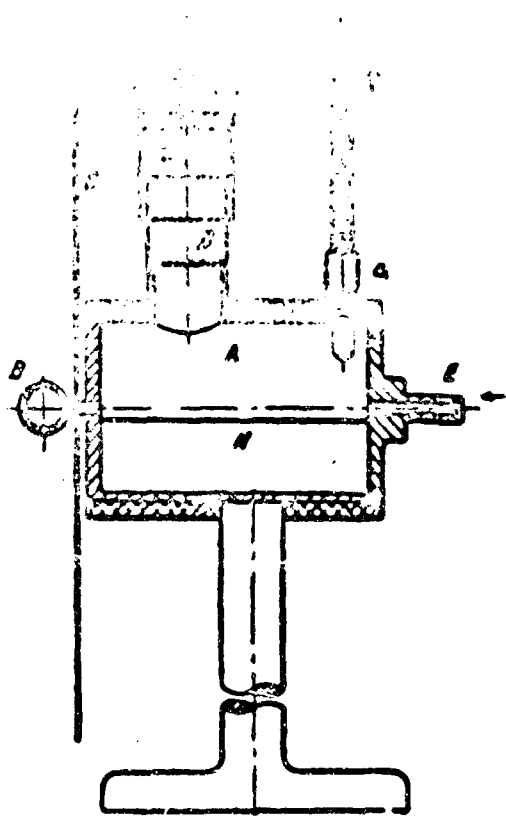

Fig.2. Diagram of apparatus for producing oil fog.

The apparatus shown in Fig. 2 was used for the production of oil fog. The apparatus consisted of a glass chamber A with a metal diaphragm N heated to 230° C. A microburette M with 0.02 cm<sup>3</sup> scale-division. The microburette was filled with oil, which was fed onto the metal diaphragm N heated to 230° C. A cock fitted to the microburette allowed the desired quantity of oil to be fed into the oven, while the glass tube 2 allowed the oil-feed to be observed.

Through pipe E there flowed into the oven a stream of filtered air heated to 230° C, at a speed of 0.2 l/min. In the oven, this air became saturated with oil vapor. The oil vapor passed into the tee and in the long pipe was diluted with a stream of cold air flowing at a speed of 40 l/min. The diluted stream was then supersaturated, which caused the formation of an aerosol. The aerosol thus produced was led for a period of 1.5 minutes into the smoke-chamber, into which the foreign vapors had previously been introduced. In the chamber, the aerosol and vapors were mixed by means of the fan for a period of one minute, after which they were tested. Thanks to the screen C and the air-cooling effect in the long pipe, the diluted stream did not heat up more than 1.5° when the oven temperature was 230°. Thus the supersaturation-temperature of the vapor practically did not change.

In all the tests the temperature of the oven was held at 230° to within  $\pm 0.5^\circ$ . If this temperature-control is strictly maintained throughout the period of aerosol-formation, the method here described of producing oil fogs will produce aerosols which can be rigorously duplicated.

For producing stearic acid aerosol we used the apparatus shown in fig.3.

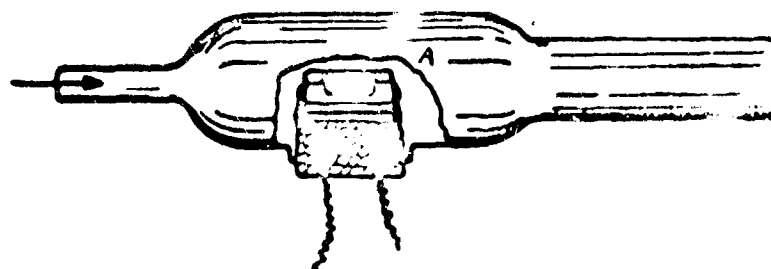

Fig.3. Diagram of apparatus for producing stearic acid and paraffin aerosols.

An exactly weighed portion of stearic acid was sprinkled with previously roasted sand into a hollow in an asbestos stopper, in which a spiral platinum wire was mounted. The drawn-out end of the glass tube A led through an opening into the chamber. A stream of filtered air was passed through the tube A at a velocity of 40 l/min. The aerosol formed in the air-stream was thus fed into the chamber, into which the foreign vapor had previously been introduced.

The stearic acid was volatilized by heating the spiral wire with an electric current for a period of 1.5 minute; the degree of heating was checked with a voltmeter.

The vapor of the foreign substance was brought into the chamber by blowing off a liquid surface in a closed vessel (fig.4)

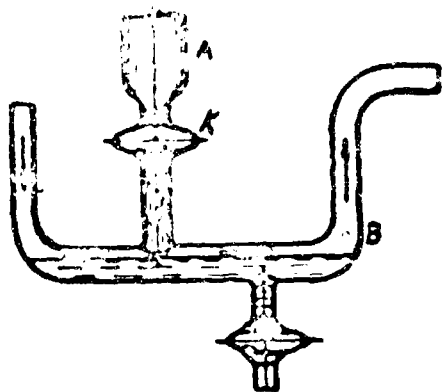

Fig.4. Diagram of apparatus for producing foreign vapors.

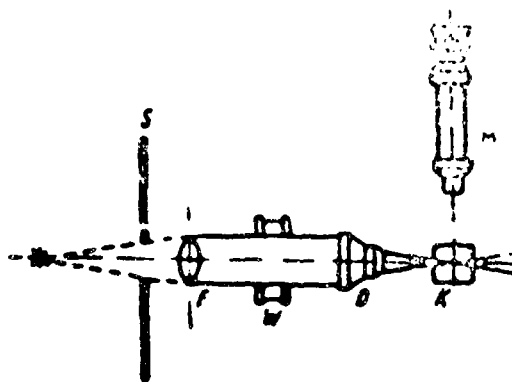

Fig.5. Diagram of the ultra-microscope set-up.

The apparatus was installed in a thermostatic chamber, in which a constant temperature was maintained.

The substance of which it was desired to have the vapor was placed in vessel A; by means of the cock K it was admitted into the U-shaped tube until the latter was half full. Filtered air was passed through the U-tube at a velocity of 0.1 - 2 l/min, carrying off the vapor of the substance from the surface of the liquid and taking it into the chamber. In order to get the whole volume of the chamber more completely saturated with vapor, we also put into the chamber sheets of filter paper soaked with the substance, and we painted it onto the chamber walls. In all the tests, the vapor in the chamber was thoroughly mixed with the fan for a period of 2 minutes before the introduction of the aerosol.

The concentration of vapor in the chamber was determined from the difference in weight of the apparatus before and after blowing off the vapor. In our experiments this concentration varied from 0.5 mg/m<sup>3</sup> to nearly complete saturation.

We checked by the absence of Tyndal's cone that no aerosol of the foreign vapor was formed in the chamber before the introduction of the test aerosol.

This method permits the desired quantity of foreign vapor to be introduced into the chamber with sufficient exactitude.

The aerosol coagulation was measured by means of a count of particles in a gas-cell, using an adapted type of ultramicroscope with dark-field illumination (fig.5).

As light-source, a 300-watt moving-picture projector lamp was used. To get rid of convection in the cell K, the lamp was shielded from the ultramicroscope set-up by the aperture-screen S and the water-filter W. The optical system used was: (a) condenser E, (b) source of objective D; (c) microscope M consisting of ocular and objective.

The concentration by weight of the aerosol was determined by weighing a fixed volume of aerosol absorbed in a filter.

\* This means the apparatus of Fig.4. (Tr.)



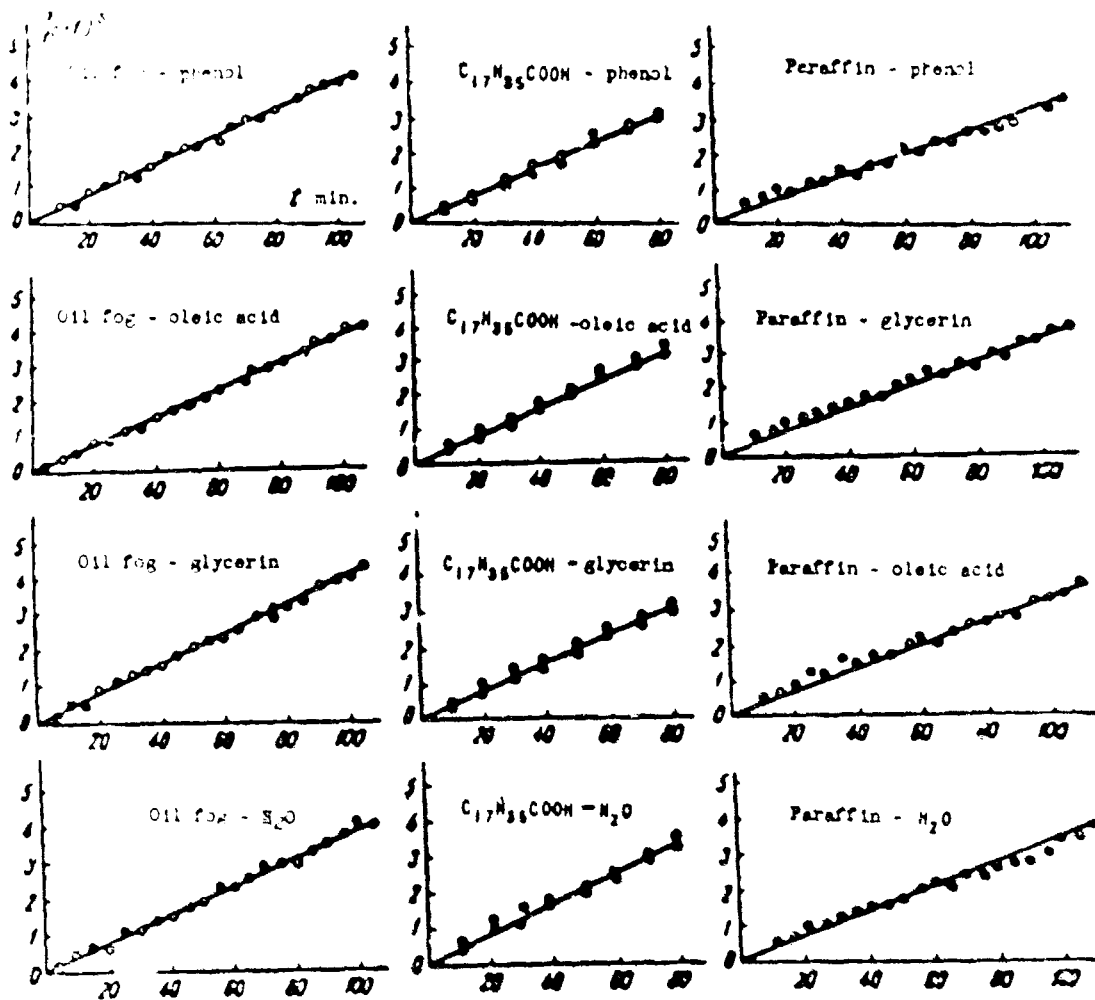

Fig. 1. Coagulation curves; abscissae are times in minutes and ordinates are partial concentrations.

...the ... of ... to ... ..  
... ..  
... ..

#### EVALUATION OF RESULTS

There exists the notion, which has very little foundation, that an aerosol particle may under some conditions have on its surface a thick gaseous envelope, firmly bound to the particle by sorptive forces and capable of decreasing the coagulation-speed of the aerosol (1,3,4,5,6,7,9)

The notion of the existence of thick stable gaseous envelopes is commonly invoked to explain the more obscure properties of aerosols. Our experiments and a number of other experimental findings (10,11,12,13,14,15,16,17) refute this notion

The results of our experiments are in agreement with researches carried out by Brandt (10), who from his observations on dust particles came to the conclusion that in the case of these particles too the adsorbed gaseous layers could hardly have a thickness greater than one molecule.

Brandt's observations demonstrate that the thick gaseous envelopes which are occasionally formed in aerosols must not be ascribed to stable adsorptive forces; they are gaseous layers held only in a temporary fashion by the aerosol, and may be easily stripped off.

In good agreement with these observations are the researches of Remi and his associates (11), who showed that the poor absorption of  $SO_2$  and  $P_2O_5$  fogs by water, when these substances are bubbled through it, may be explained by air being mechanically captured by the particles. Moreover these observations are not contradicted by Vell's experiment (12).

Likewise in connection with the reduced density of aerosol particles which has been observed (18), there is no need to drag in the notion of thick stable gaseous envelopes. Abnormally small densities of aerosol particles may be explained simply by the fact that it is necessary to determine this quantity from the hydrodynamic properties of the particle. Kahlschützer and Lüscher (13), Whytlaw-Gray and Patterson (14) have shown from a great deal of experimental material that with free-falling aerosol particles of porous and complex structure excessively low values are obtained for the density of the particles.

The notion of the existence of thick stable gaseous envelopes is also invoked to explain variations in small-particle evaporation phenomena. Work by ... (15), Schäfer (16) and Nestle (17) has shown that, in pure steam, ... small droplets of mercury evaporate in accordance with the ordinary kinetics of evaporation.

Changes in the vapor-tension of the particles, and consequently in the kinetics of their evaporation, may be observed only in those cases where the particles change their properties through interaction with the dispersion medium. For instance, the absorption of vapors in the air by aerosol particles may cause a change in the vapor-tension and evaporation-speed of the particles. In this sense we must explain the results obtained by ... and ... (20) who studied the evaporation of water droplets in atmospheres of hydrogen and of carbon dioxide. In these experiments, the evaporation in hydrogen proceeded at a speed of just the order of the theoretical value calculated for droplets of this size, while there was a decrease in diameter in

... that any slow-down in the rate of sedimentation of an aerosol is due to the formation of a stable aerosol, the nucleus of which is formed by the particles of the foreign vapor, the aerosol particles being in the protected condition. Nevertheless, some change in the aerosol character is observed, particularly a slow-down when vapors of foreign substances are in the air. We selected in cases where the adsorption or absorption of foreign vapors cause changes in the form of the aerosol particles. We observed just this effect in the case of the ammonium chloride aerosol when acted upon by water vapor, and shall give more detailed information thereon in a later article.

#### CONCLUSIONS

- 1) We made a diagrammatic synopsis of results obtained by previous authors on aerosol stabilization, this showed up certain errors of method in their experimental work.
- 2) We worked out methods of producing aerosols and vapors of various substances for purposes of studying the effect of foreign vapors on the stabilization of aerosols. These methods are such as to ensure that the results obtained will be properly duplicable.
- 3) We investigated the coagulation of oil fog, stearic acid and paraffin aerosols in the presence of phenol, oleic acid, glycerin and water vapor, and showed that the coagulation of the said aerosols in the presence of the said vapors proceeds at the same speed as in their absence.

Aerosol Laboratory  
of the  
Institute of Colloid Electrochemistry  
of the  
Academy of Sciences, USSR

Received July 12, 1945

1. S. I. MEYER, Jour. Phys. Chem. 2, 203, 1931. (R)
2. S. S. KOWALSKI and S. N. KUZMENKO, Jour. Phys. Chem. 6, 897, 1935. (R)
3. K. I. SAMOKHYALOV and O. S. KOZHUKHOVA, Jour. Phys. Chem. 8, 420, 1936. (R)
4. V. I. SAICHUK and O. G. NARSIKH, Colloid Jour. 2, 9-10, 841, 1936. (R)
5. N. N. ANDREYEV and S. G. KIBIRKSHITS, Jour. Gen. Chem. 6, 1698, 1936. (R)
6. L. V. SMIRNOV and V. A. SOLNTSEVA, Colloid Jour. 14, 5, 401, 1938. (R)
7. L. V. RADUSHKEVICH and O. K. CHUGUNOVA, Jour. Phys. Chem. 12, 34, 1938. (h)
8. I. V. PETHIANOV, N. N. TUNITSKI, M. V. TIKHOMIROV, Jour. Phys. Chem. 15, 811, 1941. (R)
9. Whytlaw-Gray and Patterson, Smoke, 14, 64, 1934 (R, translation from English).
10. Brandt, Kolloid. Z., 83, 24, 1928. (G)
11. Remi, Z. Elektrochem., 28, 469, 1922; Remi u. Ruhland, Z. anorg. Chem. 39, 5, 1924; Remi u. Fiunern, ibid. 50, 241, 1927.
12. MEL'DAU. Dust in production processes and means for its suppression. GTI, 37, 1931. (R, probably translation from German).
13. Kahlschützer und Tüscher, Z. Elektrochem. 27, 225, 1921. (G)
14. Whytlaw-Gray and Patterson, Smoke, 86, 1934. (R, translation from English)
15. Sanzenbacher, J. Phys., 39, 251, 1926.
16. Schäfer, Z. Phys., 77, 198, 1932.
17. Nestle, Z. Phys., 77, 174, 1932.
18. K. I. SAMOKHYALOV, Jour. Phys. Chem. 19, 4, 611, 1937. (R)
19. Yu. I. VEITSER, G. L. LUCHINSKI, Chemistry and Physics of Camouflage Smokes, 170, 172, 1938. (R)
20. GUDRIS and KULIKOVA, Jour. Russ. Phys.-chem. Soc., Phys. Section 56, 167, 1924. (R)