

ay 1



LASER PHOTOGRAPHIC TECHNIQUE FOR DIRECT PHOTOGRAPHY IN AN AEROBALLISTIC RANGE

P. H. Dugger and J. W. Hill

ARO, Inc.

February 1969

This document has been approved for public release
and sale; its distribution is unlimited.

**VON KÁRMÁN GAS DYNAMICS FACILITY
ARNOLD ENGINEERING DEVELOPMENT CENTER
AIR FORCE SYSTEMS COMMAND
ARNOLD AIR FORCE STATION, TENNESSEE**

NOTICES

When U. S. Government drawings specifications, or other data are used for any purpose other than a definitely related Government procurement operation, the Government thereby incurs no responsibility nor any obligation whatsoever, and the fact that the Government may have formulated, furnished, or in any way supplied the said drawings, specifications, or other data, is not to be regarded by implication or otherwise, or in any manner licensing the holder or any other person or corporation, or conveying any rights or permission to manufacture, use, or sell any patented invention that may in any way be related thereto.

Qualified users may obtain copies of this report from the Defense Documentation Center.

References to named commercial products in this report are not to be considered in any sense as an endorsement of the product by the United States Air Force or the Government.

LASER PHOTOGRAPHIC TECHNIQUE FOR
DIRECT PHOTOGRAPHY IN
AN AEROBALLISTIC RANGE

P. H. Dugger and J. W. Hill
ARO, Inc.

This document has been approved for public release
and sale; its distribution is unlimited.

FOREWORD

The research reported herein was sponsored by the Arnold Engineering Development Center (AEDC), Air Force Systems Command (AFSC), under Program Element 6540215F, Project 4344, Task 11.

The results of the research presented were obtained by ARO, Inc. (a subsidiary of Sverdrup & Parcel and Associates, Inc.), contract operator of AEDC, AFSC, Arnold Air Force Station, Tennessee, under Contract F40600-69-C-0001. The experimental data were obtained between April and July, 1968, under ARO Project No. VT5811, and the manuscript was submitted for publication on September 13, 1968. Materials were purchased under ARO Project No. VG2749.

This technical report has been reviewed and is approved.

Marshall K. Kingery
Research Division
Directorate of Plans
and Technology

Edward R. Feicht
Colonel, USAF
Director of Plans
and Technology

ABSTRACT

A front-lighted photographic system employing a giant-pulse ruby laser as a light source has been developed and installed in the 1000-ft hypervelocity Range G of the von Kármán Gas Dynamics Facility. Preliminary results indicate that this photographic technique provides an excellent method for in-flight examinations of model integrity, surface condition, and for accurate in-flight measurements of model profile dimensions (± 0.002 in.) and their changes that might be produced by erosion or ablation.

CONTENTS

	<u>Page</u>
ABSTRACT	iii
I. INTRODUCTION	1
II. DESCRIPTION	
2.1 Optical Arrangement.	1
2.2 Laser System	2
III. PRELIMINARY RESULTS	2
IV. IMPROVED SYSTEM.	5
V. ACCURACY OF LENGTH MEASUREMENTS	6
VI. CONCLUSIONS	6
REFERENCES	7

APPENDIX

Illustrations

Figure

1. Laser Photographic System.	11
2. Laser Photograph of a Model in Flight within Range G, Demonstrating the Capability for Detection of Model Damage	12
3. Laser Photographs of Lenticular Models	
a. Static	13
b. 4600 ft/sec	13
c. 9000 ft/sec	13
d. 13,000 ft/sec	13
e. 18,000 ft/sec	13
4. Semiangle Blunt Cone (25-deg)	
a. Static	14
b. In Flight	14
5. Comparison of Laser Photograph and Shadowgram of a Model with High Density Gradients in the Nose Region	
a. Shadowgram	15
b. Direct Laser Photograph	15
6. Improved Laser Photographic System	16
7. Semiangle Cone (10-deg)	
a. Static	17
b. In Flight at 12,750 ft/sec	17
c. In Flight at 16,500 ft/sec	17

SECTION I INTRODUCTION

Schlieren and shadowgraph techniques have been used extensively in aeroballistic ranges as means of examining hypervelocity projectiles and their flow fields. With these techniques, models appear in silhouette in the resultant photographs. Very little information regarding the actual condition of model surfaces, other than gross effects, can be gained. Radiation from heavily ablating models tends to fog portions of schlieren and visible-light shadow photographs, thus obliterating even model profile information. Under certain aeroballistic range conditions, high aerodynamic density gradients near the nose regions of the models produce considerable distortion in visible-light shadow photographs of such models. These distortions result primarily from refraction effects; in some cases, the luminosity of these nose cap regions is also sufficient to produce fogging of the film.

The Q-switched ruby laser has characteristics which make it an excellent light source for use in a front-lighted photographic technique for obtaining photographs of models in flight within aeroballistic ranges. The short time duration of the laser pulse effectively "stops" motion, the high intensity provides adequate film exposure, and the monochromaticity allows filtering of unwanted light.

A brief description of the laser photographic technique developed and employed successfully in the 1000-ft hypervelocity range (Armament Test Cell, Hyperballistic (G)) of the von Kármán Gas Dynamics Facility (VKF) is given, and some initial results are presented herein.

SECTION II DESCRIPTION

2.1 OPTICAL ARRANGEMENT

The direct-photographic system is shown schematically in Fig. 1 (Appendix). The beam from a pulsed ruby laser is diffused by a ground glass, and a portion of the diffuse light is directed by a 47-mm focal length (f. l.) lens into a 508-mm f. l. collimating lens. This expanded beam (approximately 5 in. in diameter) is used to illuminate models in flight. A white cardboard diffusing screen is placed perpendicularly to the expanded beam. This diffusing screen serves to delineate the model.

The camera (4- by 5-in. Graflex[®]) is mounted directly above the laser, and the optical axis of the camera forms an angle of approximately 15 deg with the laser beam. The camera employs a 360-mm f. l. lens. The lens is stopped down ($f/D = 25$) to produce a 4-in. depth of field. A greater depth of field may be obtained by stopping the camera lens more, provided sufficient light intensity is available. A narrow bandpass filter (maximum transmission = 60 percent at $\lambda_0 = 6943 \text{ \AA}$, $\Delta\lambda_{1/2} = 15 \text{ \AA}$) at the camera lens severely attenuates light other than that at the laser wavelength. This allows operation of the camera in an open-shutter mode, since there is little or no 6943 \AA background light.

A red-sensitive film (Kodak S0243[®]) is used. This film has an ASA emulsion speed rating of 1.6 and a resolution of 500 lines/mm.

Both the camera lens and the collimating lens are mounted in range ports in such a manner that the lenses serve also as vacuum-tight windows.

This system is customarily installed in Range G at an axial location 64 ft from range entrance. (Other such systems are available at other locations.)

2.2 LASER SYSTEM

The laser system employed in the front-lighted photographic technique is a pulsed ruby laser, Korad Corporation Model K-1CQ. The laser is operated in the Q-switched mode using a pockels cell. Characteristics of the laser system are as follows:

Peak power	~ 50 Mw
Energy output	1.09 J
Pulsewidth (FWHM)	22 nsec
Beam divergence (0.5 angle, 0.5 power)	~ 4 mrad
Wavelength	6943 \AA
Linewidth	0.1 \AA

SECTION III PRELIMINARY RESULTS

Photographs have been obtained of several model configurations at velocities from 4600 to 20,000 ft/sec. These heretofore unavailable photographs enable valuable in-flight examinations of model integrity and surface condition.

Figure 2 shows a laser photograph of a model which was damaged during launching. This photograph shows quite clearly the location and extent of a small area of damage along the edge of the model. This slight model damage was not evident in visible-light shadowgrams, X-ray shadowgrams, or schlieren photographs. Surface damage such as that depicted in Fig. 2 can significantly alter the aerodynamic behavior of a model and its flow field.

Figure 3 shows laser photographs of lenticular models, both statically and in flight at various velocities. There is a marked difference between the appearance of the model surface in the photographs made under in-flight conditions and in the one made at static conditions. The model appears as would be expected in the static photograph (Fig. 3a); the shiny model surface reflects the laser light specularly. In each photograph of the model in flight, however, the forward portion of the model appears to reflect as a diffuse surface, and there is an apparent effect of velocity. In Fig. 3b (velocity = 4600 ft/sec), the model surface reflects specularly except for a small diffusely reflecting region on the nose, whereas, in the photographs of higher velocity models (>9000 ft/sec), the entire forward portion of the model appears in each photograph as a diffusely reflecting surface (Figs. 3c, d, and e). At 18,000 ft/sec (Fig. 3e), the nose region appears to be nonreflecting (in the direction of the camera). These phenomena were consistently observed, i. e., all photographs of these lenticular models at nominally 4600 ft/sec show the "white spot" or diffuse nose region, whereas all photographs made at higher model velocities show the entire front portion of the model to reflect diffusely. Likewise, the "dark nose" appearance was consistently obtained on shots at velocities of nominally 18,000 ft/sec.

Photographs of a 25-deg semiangle cone made under static and in-flight (19,690-ft/sec) conditions are shown in Fig. 4. Again, the reflection characteristics of the model surface appear distinctly different for the two conditions. This in-flight appearance (Fig. 4b) was observed in all laser photographs of this model configuration at velocities of nominally 20,000 ft/sec and range pressures of nominally 40 torr.

Figure 5 shows a laser photograph and a conventional visible-light, Fresnel lens shadowgram obtained during the flight of a 1-in. -diam steel sphere (velocity: 10,800 ft/sec; range pressure: 731 torr). The design of the Fresnel lens shadowgraph is described in detail in Ref. 1. Conditions of this shot were such that high aerodynamic density gradients were established in the region just forward of the sphere. These high density gradients produced intense refraction effects which seriously distorted the visible-light shadowgraph results as demonstrated in Fig. 5a. (No noticeable distortions were observed in X-ray shadowgrams

from this shot.) The laser photograph (Fig. 5b) shows an apparently undistorted view of the sphere as well as the bow shock wave. The film negative of this photograph was examined on a Benson-Lehner Model 29E digitized film reader, and a measurement of the horizontal diameter was found to agree with a measurement of the vertical diameter to within 0.25 percent. This indicates that high density gradients have little distorting effect on the image recorded using the front-light laser photographic technique.

Further, this example (Fig. 5) illustrates to some extent that the front-light laser photographic system is impervious to the effects of self-luminosity. A streak resulting from the luminosity of the shock cap region is evident in the shadowgram of Fig. 5a, whereas the laser photograph of Fig. 5b was not affected at all by this self-luminosity. Under some test conditions, of course, the self-luminosity (shock cap radiation and/or radiation produced by ablation processes) is much stronger, and the resultant streaking completely obliterates shadowgraph results. Unfortunately, no intensely ablating models have been launched since the laser photographic system has become operational, and therefore, direct experimental confirmation of its ability in this regard is not yet available. The example shown in Fig. 5 does illustrate the point that the self-luminosity streaking seen in the shadowgram is not visible in the laser photo. In addition, separate experiments using calibrated photomultiplier radiometers viewing through laser wavelength filters have shown that shock cap radiation, radiation from heavily ablating nylon spheres, and radiation from ablating aluminum spheres all fall at values less than 6.5×10^{-4} watts/steradian.

The bow shock wave produced by the sphere in flight in Fig. 5 is apparent in the laser photograph as well as in the shadowgram. The fact that the shock wave is visible in the laser photograph probably resulted from the diffuse reflection of light from the white background card (see Fig. 1) back through the shock wave rather than from direct reflection of the laser beam by the shock wave. This arrangement provides, in effect, a combination of a direct-photograph system and a focused shadowgraph system with a weak, diffuse light source. The focused shadowgraph technique (recording camera focused on the model) would not be expected to suffer the distortion effects produced in the conventional shadowgram (e. g., Fig. 5a). Also, the weak diffuse nature of the light source (reflections from the background card) producing these effects accounts for the fact that only very strong shock waves of the sort produced by this high velocity-high pressure sphere shot are evident in laser photographs.

The shock wave in the laser photograph (Fig. 5b) appears as a much more distinct line than is the case in the shadowgram (Fig. 5a). The

bow shock detachment distance was measured from the laser photograph and was found to agree with theory (Ref. 2) to within 15 percent. It was impossible, of course, to make such a measurement on the distorted shadowgram.

Another point of interest is that the sphere surface did not reflect diffusely as was observed on shots of all other model configurations at velocities greater than 9000 ft/sec (e. g., Figs. 2, 3, and 4). However, the range pressures on all these shots were considerably lower than the 731 torr for the sphere shot. The photograph of Fig. 5b shows only specular reflection from the shiny surface of the sphere, just as a static photograph did of the same sphere.

SECTION IV IMPROVED SYSTEM

The photographs presented above were obtained with the optical system schematized in Fig. 1. As mentioned in Section 2.1, this arrangement provides only a 5-in. -diam illuminating beam or field of view. The beam-expanding optical arrangement was changed to that shown in Fig. 6. This arrangement provides a 12-in. -diam field of view. This larger field of view alleviated trigger synchronization problems, thus improving the overall reliability of the system.

A flat, green background screen was found to produce better results than the white screen used initially. Several of the photographs in Figs. 2, 3, and 4 show a bright highlight reflected from the upper edges of the model surfaces. This effect results from the reflection of light from the white background card. The green background with its reduced reflectance to light of laser wavelength eliminates this effect, yet still provides good definition of the model edges. The green background, of course, eliminates the focused shadowgraph effect discussed earlier. (It may, therefore, be desirable in some instances to use the white background.)

Figure 7a shows a static photograph of a 10-deg semiangle cone model (Cu nose, Al base). This model configuration is shown in flight in Range G in Fig. 7b (velocity = 12,750 ft/sec; pressure = 49 torr) and in Fig. 7c (velocity = 16,500 ft/sec; pressure = 14.5 torr). Evident in the photograph of Fig. 7c are very small (< 0.03 -in. -diam) particles in the near wake of the model. These photographs demonstrate very well the performance of the improved laser photography system.

SECTION V ACCURACY OF LENGTH MEASUREMENTS

The initial results obtained with the laser photographic system suggest applications of a more quantitative nature. One of these concerns measurements of the nose recession of eroding or ablating hypervelocity models. Some of the laser photographic data have been analyzed for the purpose of determining the accuracy which could be expected when using this technique for length (e. g., nose recession) measurements. Photographs (negatives) chosen for this evaluation of accuracy were from those shots on which the following criteria were met:

1. The model configuration was such that there were characteristic dimensions in both the horizontal and vertical planes suitable for measurements.
2. The model attitude and flight path were such that the film record portrayed a well-focused, direct side view of the model.
3. The model was well illuminated by the laser beam so that both the length and diameter could be measured from the film.

The film negatives of laser photographs from shots fulfilling these criteria were examined on a Benson-Lehner Model 29E digitized film reader. The diameter and length of the model were determined from the photographically recorded image on each suitable film record. The length measurements were corrected for motion blur and were compared with fabrication inspection measurements of length (accurate to ± 0.0001 in.). The agreement between the values measured from the film and the actual values (inspection measurements) was extremely good. This agreement was consistently within ± 0.002 in. in cases where the three criteria above were met.

Criterion No. 2 cannot be met on all launchings in the aeroballistic range; however, orthogonal shadowgraph systems employed in the VKF aeroballistic ranges do produce accurate records of model attitude and flight path. Therefore, appropriate geometric correction factors can be calculated and applied to length measurements.

SECTION VI CONCLUSIONS

Initial results indicate that the laser front-lighted photographic technique provides an excellent method for in-flight examination of

hypervelocity models. Laser photographs reveal in fine detail the condition of model surfaces after launching, providing information which is not available from schlieren, shadowgraph, or X-ray results. This information is frequently of value in interpreting aerodynamic and aerophysical results. The employment of a second camera and a mirror for illumination of the "back side" of the model should allow a more complete in-flight inspection of the model surface.

The laser photographic technique is impervious to refraction and self-luminosity effects which, under some test conditions, are highly detrimental to shadowgraph, schlieren, and other photographic results. Thus, models producing high density gradients and/or ablation may be observed with no loss of clarity.

It has been shown that, under certain conditions, shock waves can be observed in the laser photographs of hypervelocity models. These preliminary results indicate that the focused shadowgraph effect could be further utilized to produce a composite picture made up of a direct photograph of the model with a shadowgram of its flow field.

Length and nose contour measurements can be accurately (± 0.002 in.) extracted from laser photographic data even under conditions of ablation, self-luminosity, and high density gradients. This introduces the possibility of erosion and ablation rate studies, since it has been shown that the high density and self-luminosity usually associated with ablation should not affect the integrity of such length measurements. Several axially spaced laser photographic stations will allow detailed observation of ablation or erosion effects and accurate determinations of ablation or erosion rates.

REFERENCES

1. Clemens, P. L. and Hendrix, R. E. "Development of Instrumentation for the VKF 1000-ft Hypervelocity Range." Proceedings of the Second Symposium on Hypervelocity Techniques, Plenum Press, 1962.
2. Hayes, Wallace D. and Probst, Ronald F. Hypersonic Flow Theory. Academic Press, New York, 1959, p. 160.

**APPENDIX
ILLUSTRATIONS**

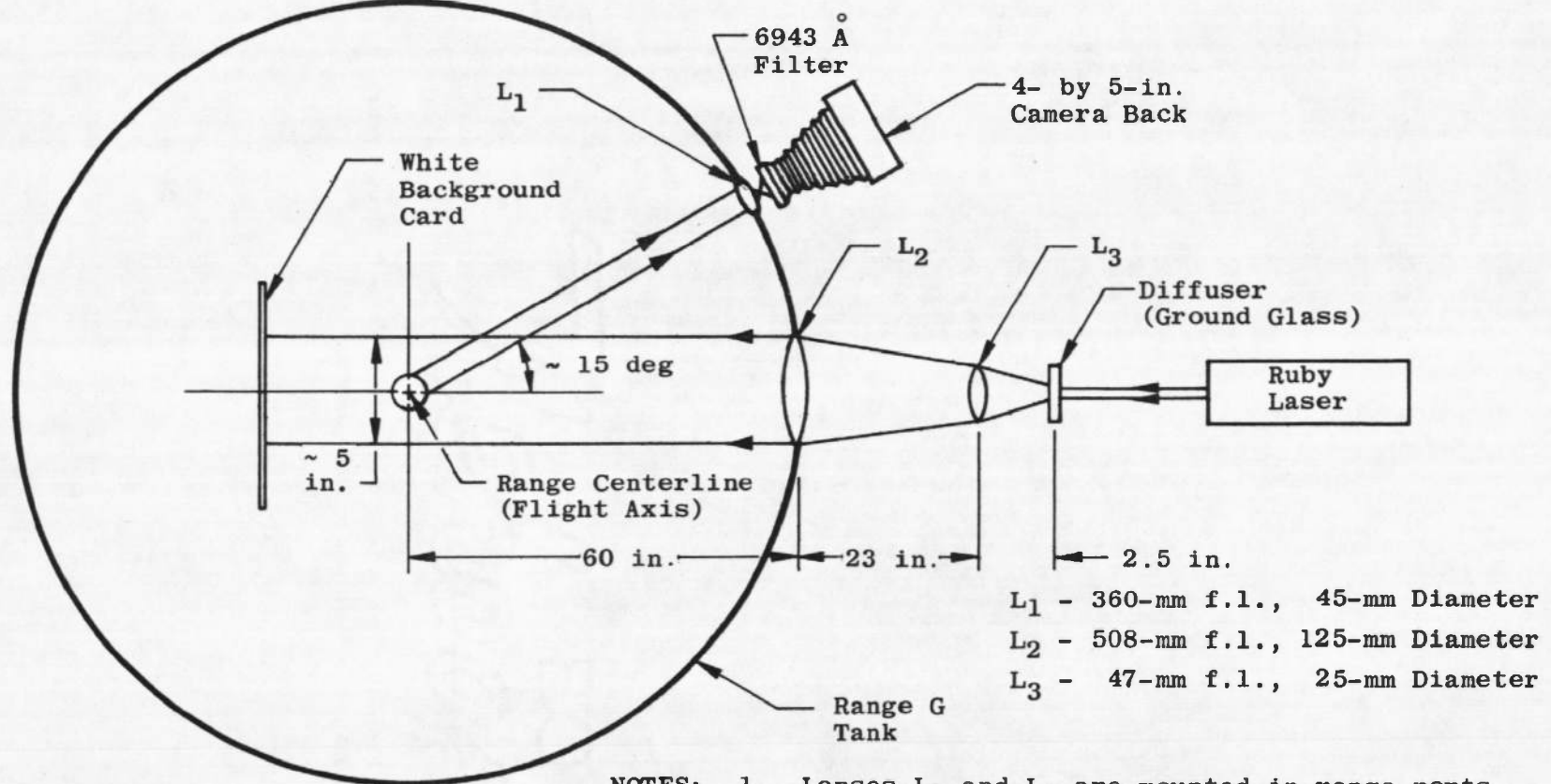

- NOTES: 1. Lenses L₁ and L₂ are mounted in range ports in such a manner that the lenses serve also as vacuum-tight windows.
2. Laser characteristics:
 Output Power, 50 mw
 Duration, 20 nsec

Fig. 1 Laser Photographic System

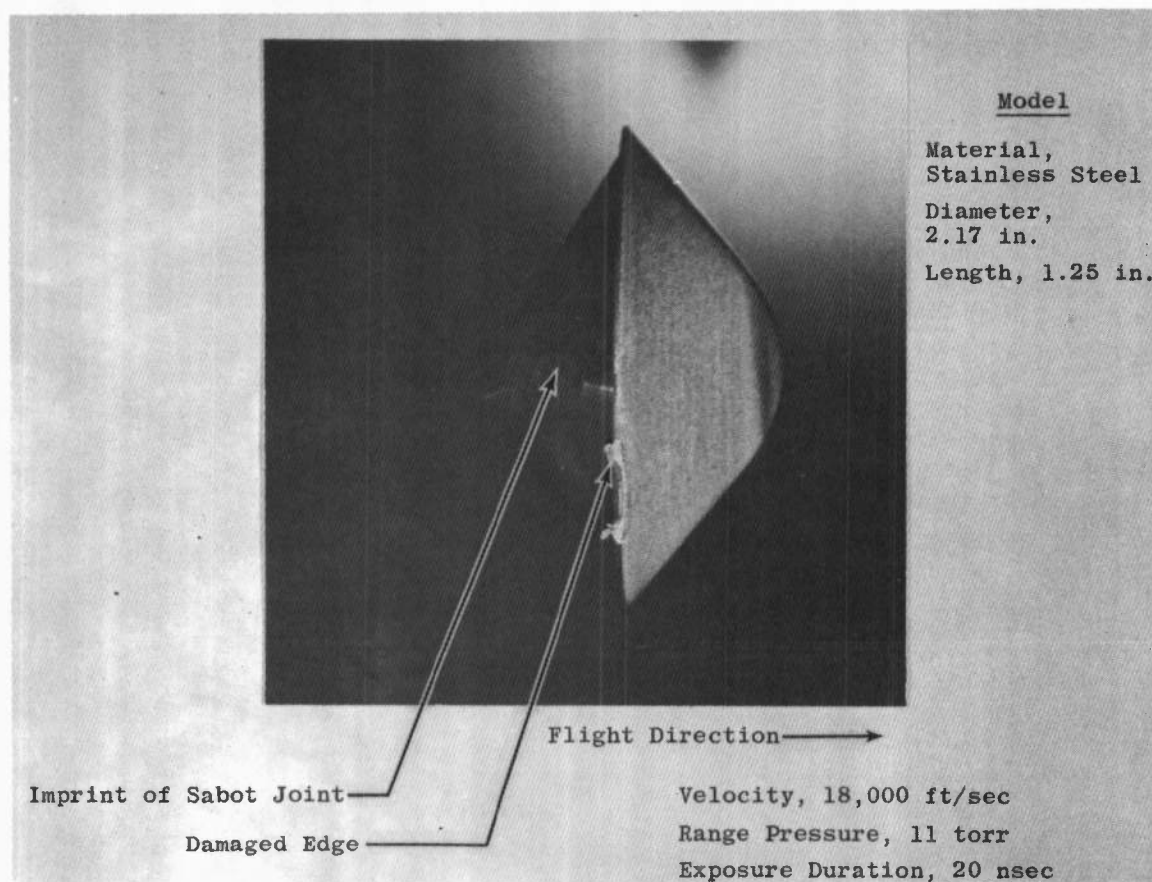
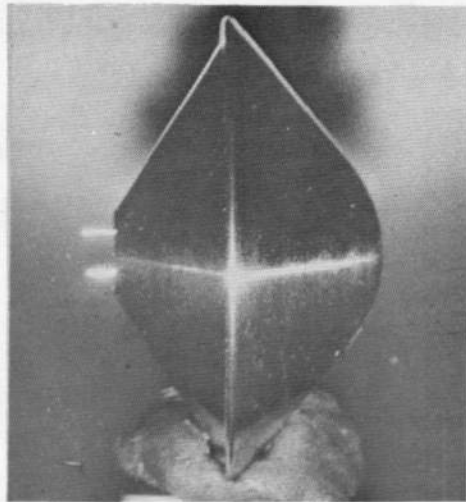
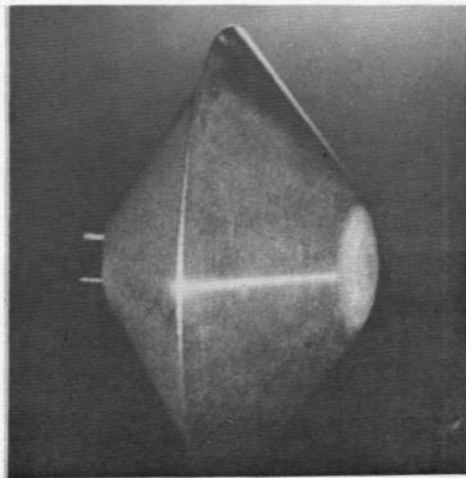

Fig. 2 Laser Photograph of a Model in Flight within Range G, Demonstrating the Capability for Detection of Model Damage



a. Static



b. 4600 ft/sec

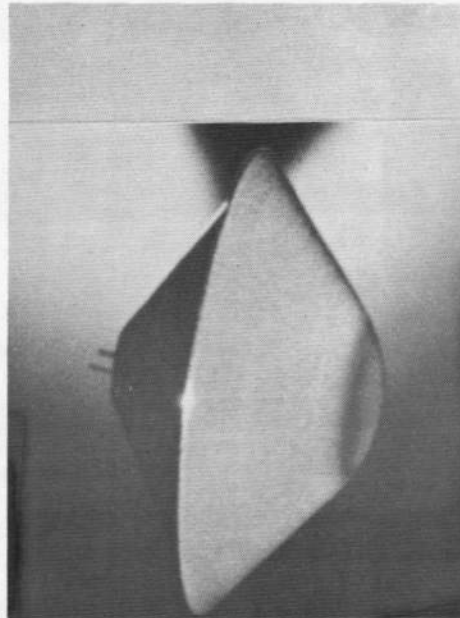

e. 18,000 ft/sec

Model

Material, Stainless Steel
 Diameter, 2.17 in.
 Length, 1.25 in.

Range Pressures, 11 torr
 Exposure Duration
 (All Cases), 20 nsec

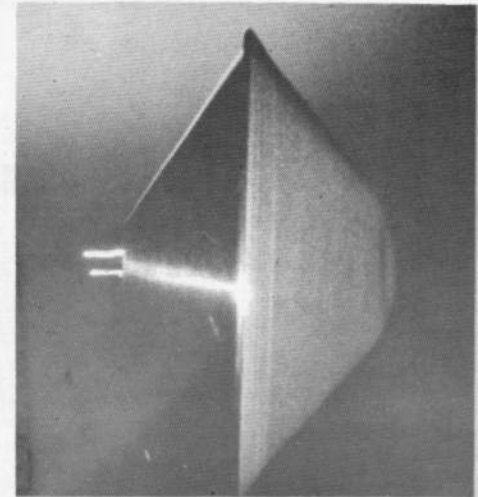

c. 9000 ft/sec

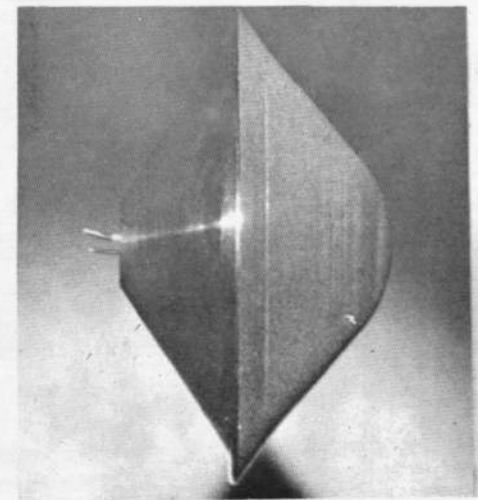

d. 13,000 ft/sec

Fig. 3 Laser Photographs of Lenticular Models

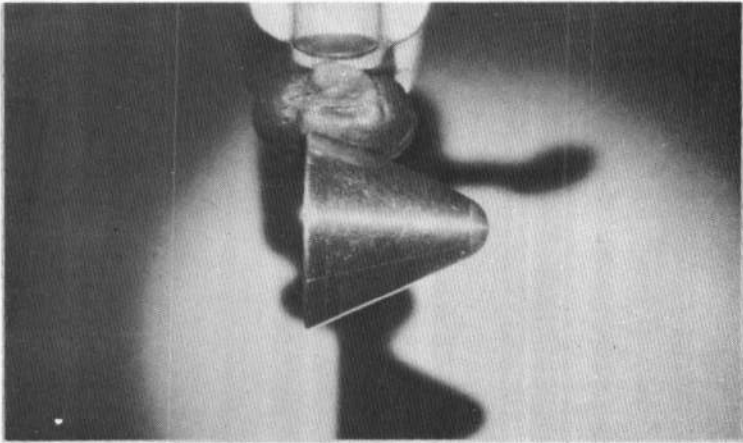

a. Static

Model

Material, Al Base;
Cu Nose

Base Diameter, 1.23 in.
Length, 1.08 in.

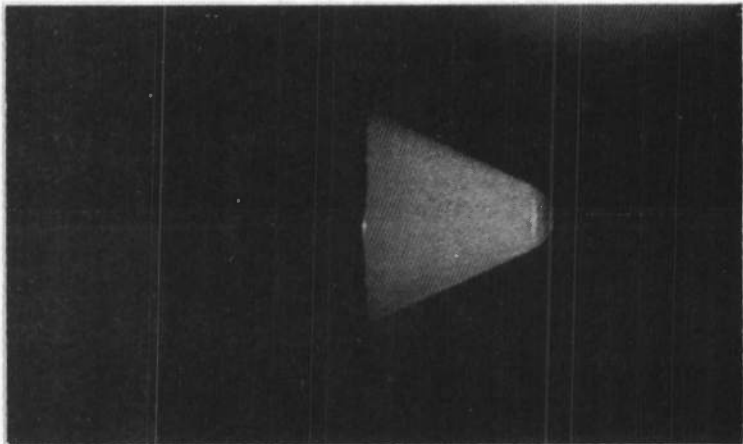

b. In Flight

Velocity, 19,690 ft/sec
Range Pressure,
40.8 torr

Exposure Duration
(Both Cases), 20 nsec

Fig. 4 Semiangle Blunt Cone (25-deg)

Self-Luminosity Streaking

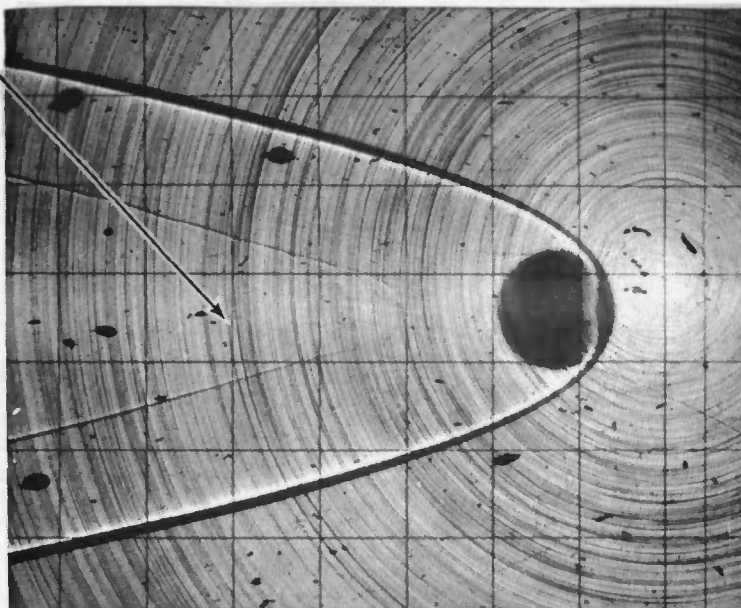

a. Shadowgram

Velocity,
10,900 ft/sec
Range Pressure,
731 torr
Steel Sphere,
1-in. Diameter

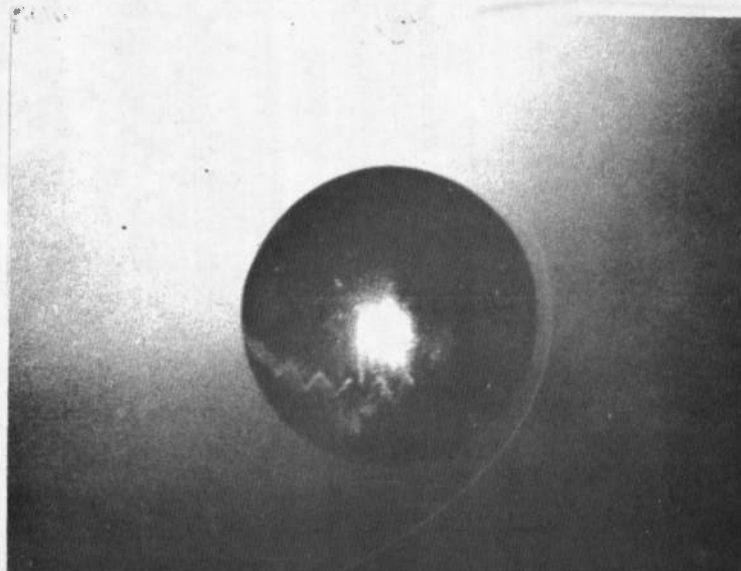

b. Direct Laser Photograph

Fig. 5 Comparison of Laser Photograph and Shadowgram of a Model with High Density Gradients in the Nose Region

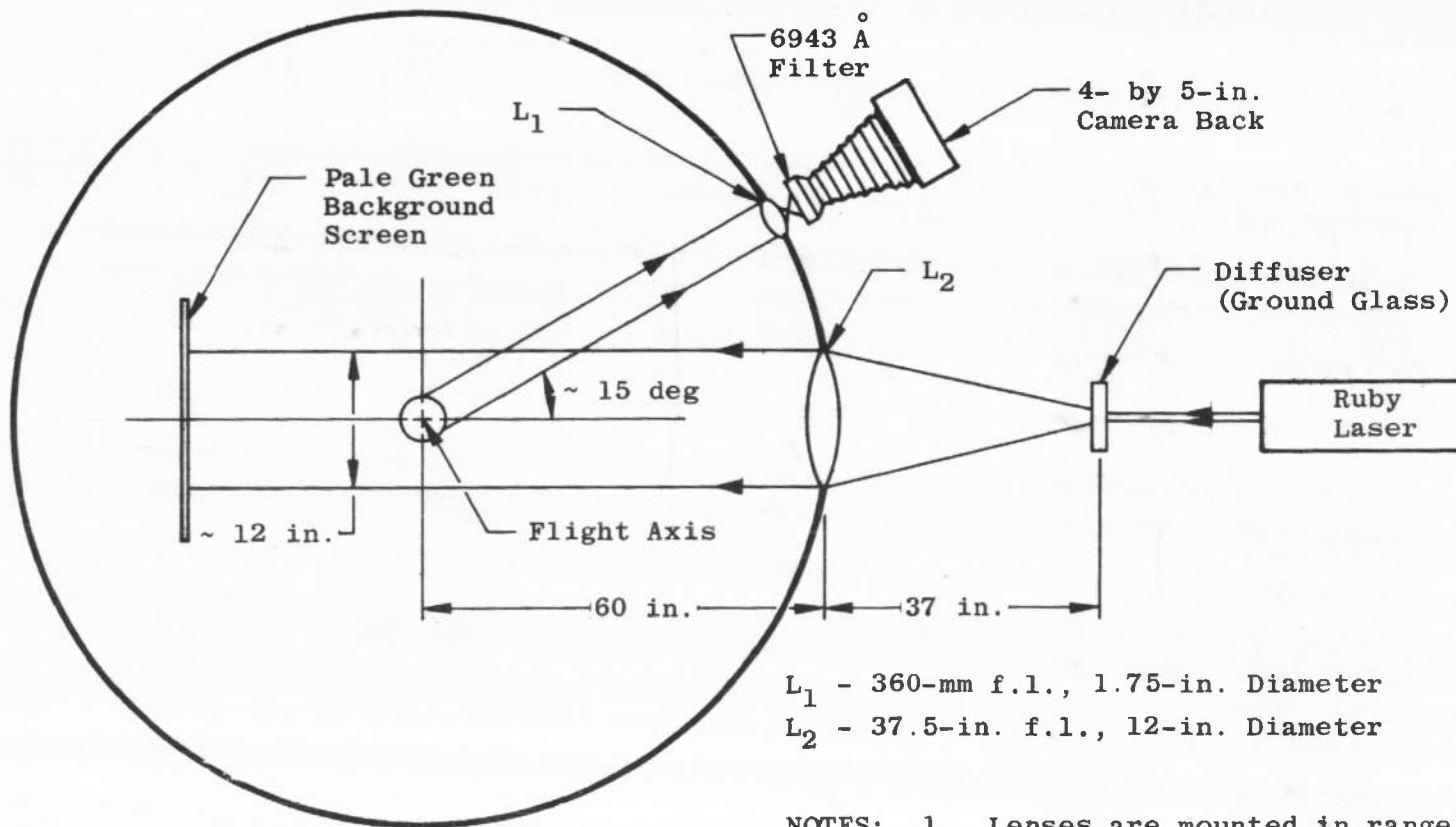

- NOTES: 1. Lenses are mounted in range ports in such a manner that they serve also as vacuum-tight windows.
2. Laser characteristics:
Output Power, 50 mw
Duration, 20 nsec

Fig. 6 Improved Laser Photographic System

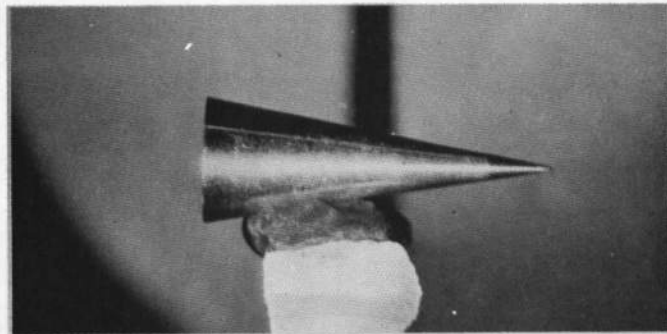

a. Static

Model
Material, Al Base;
Cu Nose
Base Diameter,
1.0 in.
Length, 2.75 in.

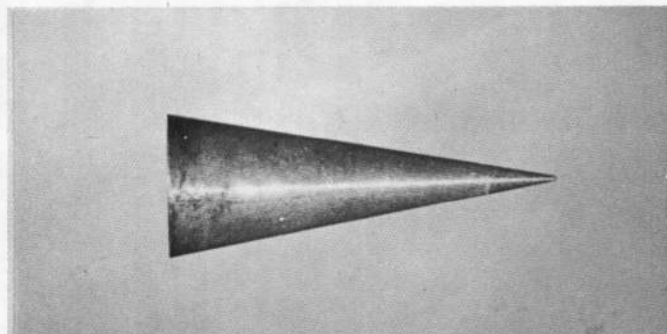

b. In Flight at 12,750 ft/sec

Range Pressure
49 torr

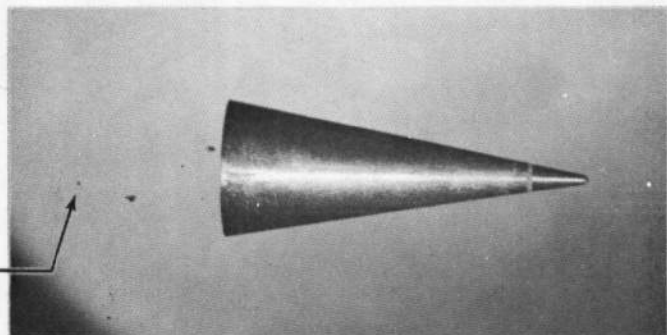

≈ 0.03-in.-
diam
Particle

c. In Flight at 16,500 ft/sec

Range Pressure
14.5 torr

Exposure Duration
(All Cases), 20
nsec

Fig. 7 Semiangle Cone (10-deg)

DOCUMENT CONTROL DATA - R & D

(Security classification of title, body of abstract and indexing annotation must be entered when the overall report is classified)

1. ORIGINATING ACTIVITY <i>(Corporate author)</i> Arnold Engineering Development Center, ARO, Inc., Operating Contractor, Arnold Air Force Station, Tennessee		2a. REPORT SECURITY CLASSIFICATION UNCLASSIFIED	
		2b. GROUP N/A	
3. REPORT TITLE LASER PHOTOGRAPHIC TECHNIQUE FOR DIRECT PHOTOGRAPHY IN AN AEROBALLISTIC RANGE			
4. DESCRIPTIVE NOTES <i>(Type of report and inclusive dates)</i> April to July, 1968 - Final Report			
5. AUTHOR(S) <i>(First name, middle initial, last name)</i> P. H. Dugger and J. W. Hill, ARO, Inc.			
6. REPORT DATE February 1969	7a. TOTAL NO. OF PAGES 22	7b. NO. OF REFS 2	
8a. CONTRACT OR GRANT NO. F40600-69-C-0001	9a. ORIGINATOR'S REPORT NUMBER(S) AEDC-TR-68-225		
b. PROJECT NO. 4344	9b. OTHER REPORT NO(S) <i>(Any other numbers that may be assigned this report)</i> N/A		
c. Program Element 6540215F			
d. Task 11			
10. DISTRIBUTION STATEMENT This document has been approved for public release and sale; its distribution is unlimited.			
11. SUPPLEMENTARY NOTES Available in DDC.		12. SPONSORING MILITARY ACTIVITY Arnold Engineering Development Center (AETS), Arnold Air Force Station, Tennessee 37389.	
13. ABSTRACT A front-lighted photographic system employing a giant-pulse ruby laser as a light source has been developed and installed in the 1000-ft hypervelocity Range G of the von Karman Gas Dynamics Facility. Preliminary results indicate that this photographic technique provides an excellent method for in-flight examinations of model integrity, surface condition, and for accurate in-flight measurements of model profile dimensions (± 0.002 in.) and their changes that might be produced by erosion or ablation.			

14.

KEY WORDS

LINK A

LINK B

LINK C

ROLE

WT

ROLE

WT

ROLE

WT

laser photographs
direct photography
front-lighted system
ruby laser
in-flight examinations
model profiles

2. Laser photographs

3. Lasers - Applications

15-18