

AD 685045



AD

TECHNICAL REPORT ECOM-0189-3

ELECTROMAGNETIC INTERFERENCE
MEASUREMENT METHODOLOGY,
COMMUNICATION EQUIPMENT

QUARTERLY REPORT

By

W. R. FREE

AND

C. W. STUCKEY

MARCH 1969

DISTRIBUTION STATEMENT

This document has been approved for public
release and sale; its distribution is unlimited.

.....
ECOM

UNITED STATES ARMY ELECTRONICS COMMAND • FORT MONMOUTH, N.J.

Contract DAAB07-68-C-0189

Engineering Experiment Station
GEORGIA INSTITUTE OF TECHNOLOGY
Atlanta, Georgia

NOTICES

Disclaimers

The findings in this report are not to be construed as an official Department of the Army position, unless so designated by other authorized documents.

Disposition

Destroy this report when it is no longer needed. Do not return it to the originator.



Reports Control Symbol
OSD-1366

TECHNICAL REPORT ECOM-0189-3

March 1969

ELECTROMAGNETIC INTERFERENCE MEASUREMENT
METHODOLOGY, COMMUNICATION EQUIPMENT

QUARTERLY REPORT NO. 3

1 AUGUST 1968 TO 31 OCTOBER 1968

CONTRACT NO. DAAB07-68-C-0189
DA PROJECT NO. 1H6 20501 D449 01 56

Prepared By

W. R. FREE AND C. W. STUCKEY

ENGINEERING EXPERIMENT STATION
GEORGIA INSTITUTE OF TECHNOLOGY
ATLANTA, GEORGIA

For

U. S. ARMY ELECTRONICS COMMAND
FORT MONMOUTH, N. J.

DISTRIBUTION STATEMENT

This document has been approved for public
release and sale; its distribution is unlimited.

ABSTRACT

Theoretical and experimental investigations directed toward the development of improved test techniques and procedures for performing radiated measurements in shielded enclosures have continued during this reporting period.

Results from previous studies indicate that the coupling variations which occur in shielded enclosures at frequencies below 100 MHz are due to near-field radially-polarized electric field components which are propagated along the walls of the enclosure. An experimental study was performed during this reporting period to test the concept that an antenna hood could isolate a probe antenna from these sidewall-propagated, near-field components. The results from this experimental program show that a low frequency antenna hood can be used to effectively isolate the probe antenna from the enclosure walls. However, insertion loss and calibration difficulties associated with the low frequency hooded antenna indicate that this solution is not without some disadvantages.

In order to obtain experimental data which are more directly applicable to high frequency short hooded antenna designs, two adjustable-length hooded antennas were fabricated and tested. Results from this measurement program indicate that a hooded antenna approximately 4 inches long will operate satisfactorily over the 1 to 3 GHz frequency range, a 2-inch long hooded antenna will operate satisfactorily over the 3 to 8 GHz frequency range and a third shorter hooded antenna will be required to cover the 8 to 12 GHz frequency range.

FOREWORD

This report was prepared at the Georgia Tech Engineering Experiment Station on Contract No. DAAB07-68-C-0189. The work covered by this report was performed within the Electronics Division under the supervision of Mr. D. W. Robertson, Head of the Communications Branch. The report covers the activities and results of the third quarter's effort on a project to develop improved test setups, procedures and equipment for measurement of radiated emission and susceptibility characteristics of military communication - electronic equipment in shielded enclosures.

TABLE OF CONTENTS

	Page
I. FACTUAL DATA	1
A. Introduction	1
B. Study of Near-Field Measurement Probes	1
1. General	1
2. Low-Frequency Hooded Antenna Experiments	5
3. Future Investigation	14
C. Short Hooded Antennas	17
1. Background	17
2. Adjustable-Length Hooded ASN 116A Antenna	18
3. Adjustable-Length Hooded ASN 111A Antenna	21
4. Future Hooded Antenna Investigations	26
II. SUMMARY	27
III. LITERATURE CITED	29

LIST OF ILLUSTRATIONS

	Page
1. Illustration of the Use of an Antenna Hood to Minimize Probe Response to Radially Polarized Fields	3
2. View of the Hooded 18-Inch Bow-Tie Probe Antenna	5
3. Relative Coupling as a Function of Antenna Separation Distance at a Frequency of 50 MHz	7
4. Relative Coupling as a Function of Antenna Separation Distance at a Frequency of 40 MHz	8
5. Relative Coupling as a Function of Antenna Separation Distance at a Frequency of 30 MHz	9
6. Open-Field Relative Coupling at 50 MHz	11
7. Open-Field Relative Coupling at 40 MHz	12
8. Open-Field Relative Coupling at 30 MHz	13
9. View of the Test Set-Up for Measuring Near-Field Mutual Coupling Patterns	14
10. Near-Field Mutual Coupling Between a Dipole and Hooded Probe Antenna at Separation Distances of 28, 36, 48 and 60 Inches	15
11. Near-Field Mutual Coupling Between a Dipole and Hooded Probe Antenna at Separation Distances of 72 and 84 Inches .	16
12. Adjustable-Length Hooded ASN 116A Antenna	18
13. Antenna Patterns for Unhooded ASN 116A Antenna at 2, 3, 4 and 6 GHz	19
14. Antenna Patterns for Unhooded ASN 116A Antenna at 7, 8, 9 and 10 GHz	20
15. Antenna Patterns for Hooded ASN 116A Antenna at 1, 2, 3 and 4 GHz	22
16. Adjustable-Length Hooded ASN 111A Antenna	23

LIST OF ILLUSTRATIONS (Continued)

	Page
17. Antenna Patterns for Unhooded ASN 111A Antenna at 4, 6, 8 and 10 GHz	24
18. Antenna Patterns for Hooded ASN 111A Antenna at 3, 4, 5 and 6 GHz	25
19. Antenna Patterns for Hooded ASN 111A Antenna at 7 and 8.5 GHz	26

I. FACTUAL DATA

A. Introduction

This report covers the work performed under Contract DAAB07-68-C-0189 for the period from 1 August 1968 to 1 November 1968.

The purpose of this program is to conduct theoretical and experimental investigations directed toward the development of improved test setups, procedures and equipment for the measurement of radiated emission and susceptibility characteristics of military communication-electronic equipment. These measurements are to be made within shielded enclosures in the near-field of the equipment under test and at frequencies at which RF absorbers are not economically feasible.

The three primary objectives of the program are (1) the development of techniques for measuring radiated interference and susceptibility characteristics in shielded enclosures over the frequency range from 20 to 200 MHz, (2) the development of broadband hooded antennas which minimize the narrowing effect of the hood on the antenna field pattern and (3) an investigation to determine the availability of broadband, balanced probe antennas suitable for radiated emission and susceptibility measurements in shielded enclosures over the frequency range from 14 kHz to 200 MHz.

B. Study of Near-Field Measurement Problems

1. General

It has previously been shown^{1,2} that the coupling nulls which occur in shielded enclosures at frequencies below 100 MHz are the result of the out-of-phase summation of the tangentially polarized direct radiation and a near-field, radially-polarized, electric field component. The radially-polarized component couples from the radiating source to the enclosure walls, propagates along the walls and couples to the probe antenna. In the open-field there is no path corresponding to the enclosure walls whereby the radially polarized field component can couple into the probe antenna. Thus coupling measurements made in shielded enclosures exhibit the effect of this radial field component and corresponding measurements made in the open-field do not. Since it is desired to measure the amplitude of the tangentially polarized field component in shielded enclosures independent of any wall-coupled, near-field effect, an investigation was undertaken to investigate probe antenna configurations with little or no response to radial fields.

One possible antenna configuration having the desired characteristic of minimum response to radially polarized fields incorporates an antenna hood. This is most easily seen by reference to Figure 1. Figure 1(a) pictorially illustrates the response of a dipole probe antenna to the radially polarized field component, E_r , in a shielded enclosure. The E_r field is incident on the enclosure sidewalls adjacent to the ends of the radiating dipole. Since E_r is orthogonal to the sidewalls, this field can be propagated over the surface of the walls. As the E_r field propagates along the sidewalls adjacent to the ends of the probe dipole, the probe will exhibit maximum response to this field and a portion of the energy will be coupled into the probe antenna. The tangentially polarized electric field, E_θ is propagated as direct radiation from the radiating to the receiving dipole as shown.

Prior to recognition of the near-field coupling theory as the cause of the coupling nulls at low frequencies, the use of conventional hooded antennas at frequencies below 100 MHz was ruled out because of two major considerations. First, to satisfy the aperture-to-wavelength requirements to obtain the directivity necessary to prevent multipath influences on measured field strengths, a low frequency conventional hood would be too large to be accommodated in shielded enclosures. Fortunately, all available data as well as calculations indicate that the dimensions of the enclosure are not large enough to permit any significant multipath interference at low frequencies. Hence, there is apparently little need for obtaining tangentially polarized field directivity with a hood. The other major objection to the use of hoods at low frequencies was that no suitable absorbing material is available with which to line the inside of the hood.

Since the problem at low frequencies is the wall-coupled, radial field effect and not conventional multipath, it was considered possible to line the inside of a low frequency hood with lossy material and, through the use of an effective balun, isolate the probe antenna from the near-field components propagated along the sidewalls as indicated in Figure 1(b).

It should be emphasized that there are distinct conceptual differences between the conventional hooded antennas employed at high frequencies and the low frequency hood depicted in Figure 1(b). In the conventional high frequency hooded antenna, the hood is used to achieve antenna directivity with respect to the tangentially polarized electric field component, E_θ . This increased directivity is utilized to minimize the effects of multipath interference (stray radiation) inside a shielded enclosure by allowing probe illumination of the radiating source while simultaneously minimizing sidewall, backwall, floor and ceiling illumination.

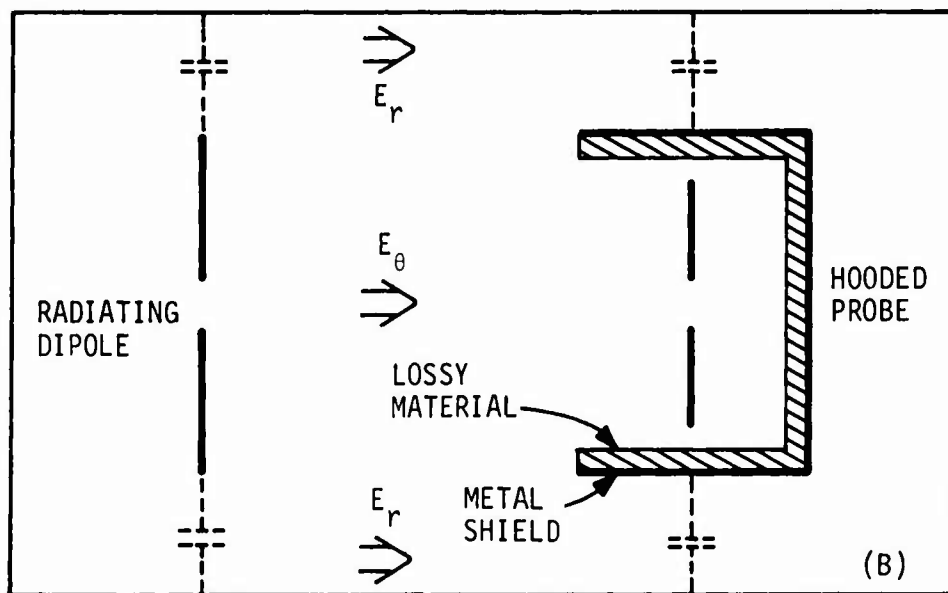
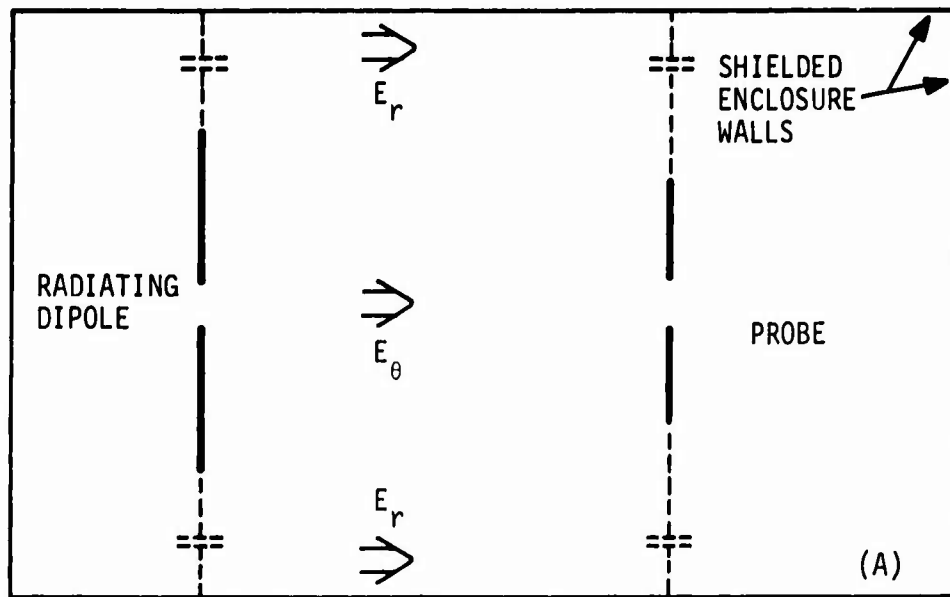

Figure 1. Illustration of the Use of an Antenna Hood to Minimize Probe Response to Radially Polarized Fields.

The inside of a conventional high frequency hood is lined with RF absorbing material and the probe antenna is isolated by a balun from the outside metal shield. In the open-field or free-space environment, measurements made at a given frequency with the probe antenna unhooded differ from measurements made with the same probe hooded by a constant factor at all far-field measurement ranges of interest. This constant factor is the insertion loss (or gain) associated with the hood. After correcting for this insertion loss, the hooded and unhooded measurements are identical at each measurement range of interest.

The concept of the low frequency hood shown in Figure 1(b) is completely different from that of the conventional high frequency hood. In the low frequency hood no increased directivity with respect to the tangentially polarized electric field component, E_{θ} , is sought or achieved. Rather, the low frequency hood is used solely to isolate the antenna from the radially polarized electric field component, E_r , propagated along the sidewalls. Although the probe antenna is isolated from the outside metal shield of the hood by a balun as is the case with conventional high frequency hoods, the inside of the metal shield is lined with a lossy material (for isolation from the inside of the metal shield) rather than an absorber. This can be done since the dimensions involved preclude significant effects from multipath reflections inside the hood itself.

The most important conceptual difference between the conventional high frequency hooded antenna and the low frequency hooded antenna is that the latter is intended for use at ranges of from a few wavelengths down to a fraction of a wavelength from the radiating source. Thus, when the low frequency probe antenna is hooded, not only is a far-field insertion loss factor present in the measured results, but the mutual coupling between the source and the probe is appreciably altered by the presence of the hood. Therefore, at longer wavelengths, it is no longer possible to correct hooded probe measurements to agree with unhooded probe measurements by a range-independent far-field insertion loss factor. It is indeed difficult and more than a little misleading to describe the low frequency probe as either hooded or unhooded in the conventional sense in which this concept is used to describe probes intended for use at higher frequencies. The hooded low-frequency probe operating very close (in terms of wavelength) to a radiating source should and, as is shown in the measurement results section of this report, does exhibit electrical characteristics quite different from those of the same probe unhooded. Instead of being described as hooded and unhooded, it may be clearer to view the two antenna configurations as two distinctly different antennas, just as differentiation is made between dipoles and horn antennas. However, in order to be consistent with previous reports, the low frequency probe antenna will be referred to herein as either hooded or unhooded.

2. Low-Frequency Hooded Antenna Experiments

In order to experimentally test the concept that an antenna hood could be used successfully in shielded enclosures at frequencies below 100 MHz to isolate a probe antenna from the near-field radially polarized components propagated along the sidewalls, a probe antenna and antenna hood were fabricated. An 18-inch bow-tie antenna with a 38-degree flare angle was built to serve as a probe antenna. An Anzac Model H-1 hybrid junction was used as the probe antenna feed and balun. The hood was constructed from an aluminum cylinder two feet in diameter and four feet long; the wall thickness was 1/8 inch. The hood end plate (back wall) was made from 1/2 inch sheet aluminum. The cylinder and end plate were lined with Emerson and Cuming NZ-1 ferrite material. While it is documented³ that this material is a very poor absorber at frequencies appreciably below 300 MHz, it has been found to be an adequate lossy material in the frequency range of interest. Figure 2 shows a view of the bow-tie probe antenna inside the antenna hood.

Antenna coupling measurements were made in an 8 x 8 x 20 foot shielded enclosure. A 30-inch bow-tie antenna was used as the source antenna for all of the coupling measurements. Initially, antenna coupling as a function of separation distance was determined between the source antenna and the unhooded 18-inch bow-tie probe antenna.

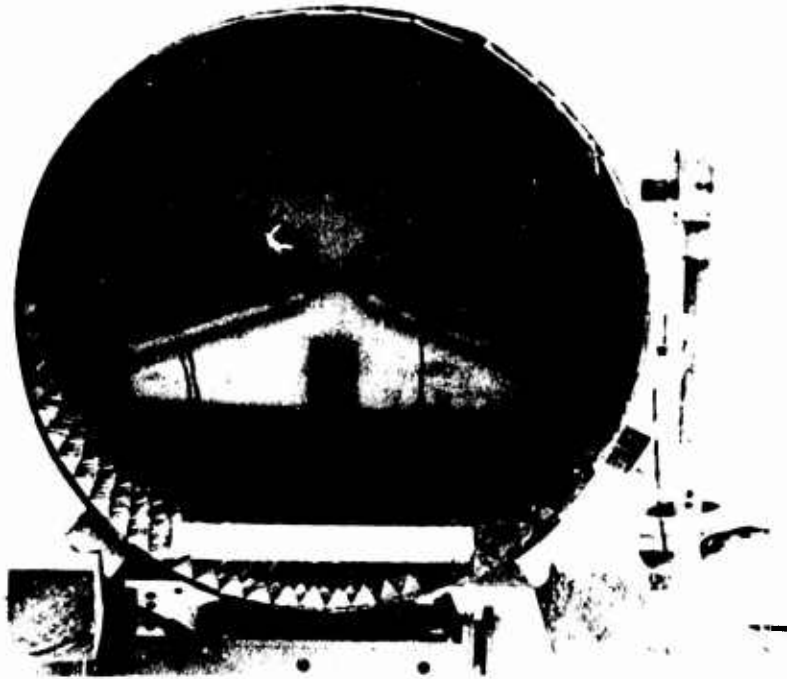

Figure 2. View of the Hooded 18-Inch Bow-Tie Probe Antenna.

The source antenna was centered in the shielded enclosure 93 inches from the end wall to correspond with previous experiments in the 20 foot chamber. Coupling measurements were made at frequencies of 50, 40 and 30 MHz. The measurements were made at 2-inch spacing increments at antenna separation distances of from 10 inches to 100 inches. The results of these measurements are shown in Figures 3, 4 and 5.

The coupling data for the unhooded probe antenna clearly show the typical low frequency coupling nulls resulting from the out-of-phase summation of the tangentially and radially polarized field components. Consistent with previously reported coupling measurements in shielded enclosures, at low frequencies, the null occurs further from the source as the frequency is decreased. A complete discussion of the reasons for this effect can be found on page 13 of reference 1.

To verify that the probe antenna could be isolated from the radially polarized near-field component propagated along the enclosure wall by the use of an antenna hood, the experiment described above was repeated with the 18-inch bow-tie probe antenna hooded as shown in Figure 2. Again the coupling measurements were made at 2-inch spacing increments at each of the three test frequencies. Measurements were made with the probe antenna located at hood depths of 3, 9 and 18 inches. It was found that the 3-inch hood depth did not provide sufficient probe antenna isolation to completely eliminate the coupling nulls. No significant differences were observed between the data recorded at a 9-inch hood depth and that recorded at an 18-inch hood depth.

The results of the coupling measurements made in the shielded enclosure with the probe antenna hooded for a 9-inch hood depth are shown in Figures 3, 4 and 5. As shown in these curves, sufficient isolation was provided by the antenna hood to prevent coupling of the E_r component into the probe antenna. Hence, no coupling nulls are evident in the hooded antenna data.

To compare the hooded antenna coupling measured in the shielded enclosure with corresponding data from open-field measurements, the shielded enclosure experiments described above were repeated on the roof antenna range. The open-field coupling data obtained with the hooded antenna are also shown in Figures 3, 4 and 5. The agreement between the hooded antenna measurements in the shielded enclosure and corresponding measurements in the open-field is quite good. Out to a separation distance of just over one meter, the two sets of measurements are identical to within the accuracy of the measurement equipment. At separation distances in excess of 50 inches, a detectable difference in coupling is seen. The coupling in the open-field falls off more slowly with distance than it does in the shielded enclosure. At a separation distance of 100 inches, the difference between the open-field and shielded enclosure measurements is approximately 3 dB.

- UNHOODED IN SHIELDED ENCLOSURE
- HOODED IN SHIELDED ENCLOSURE
- △ HOODED IN OPEN-FIELD

FREQUENCY = 50 MHZ
 ANTENNA HOOD DEPTH = 9-INCHES

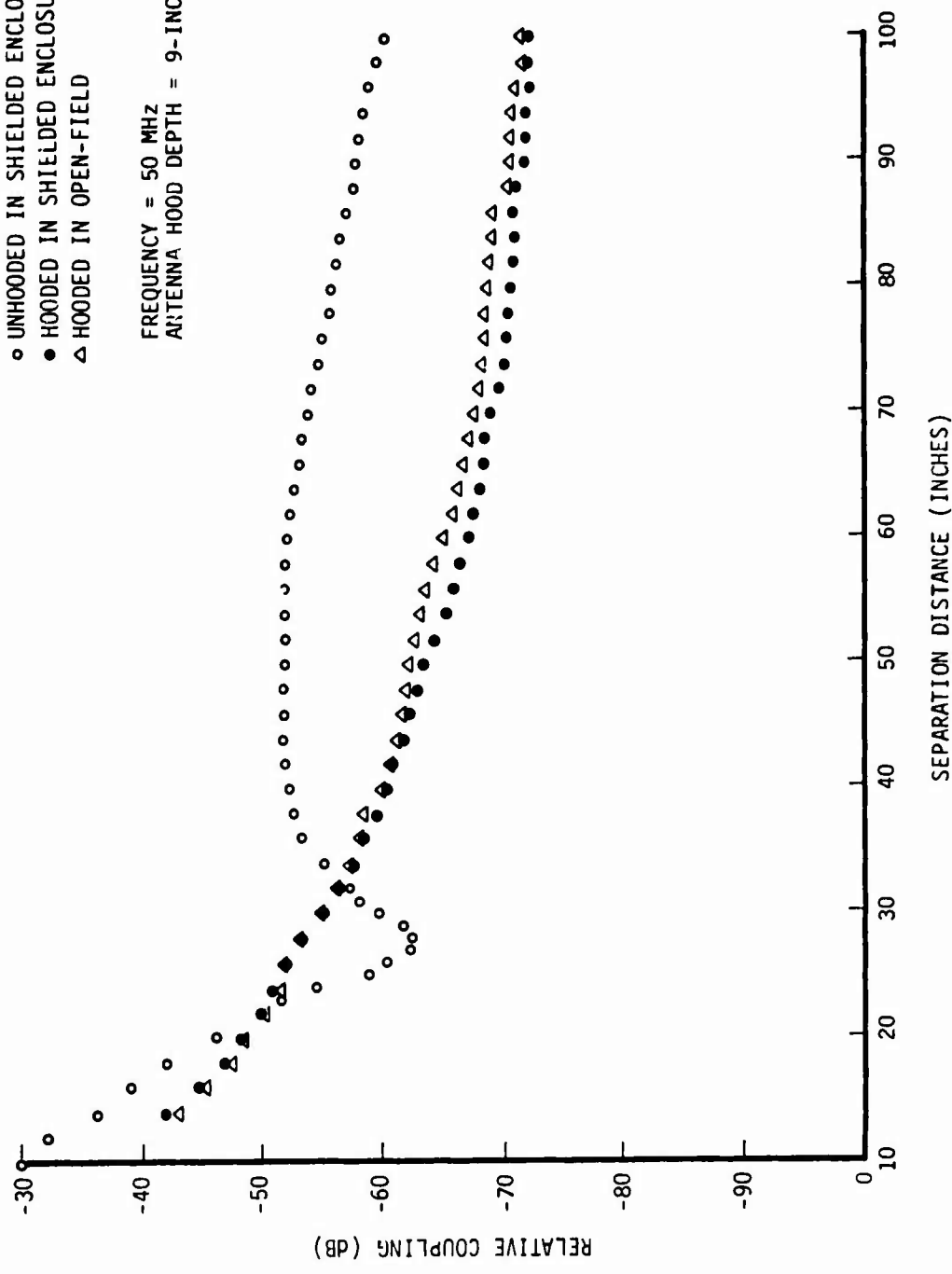

Figure 3. Relative Coupling as a Function of Antenna Separation Distance at a Frequency of 50 MHz.

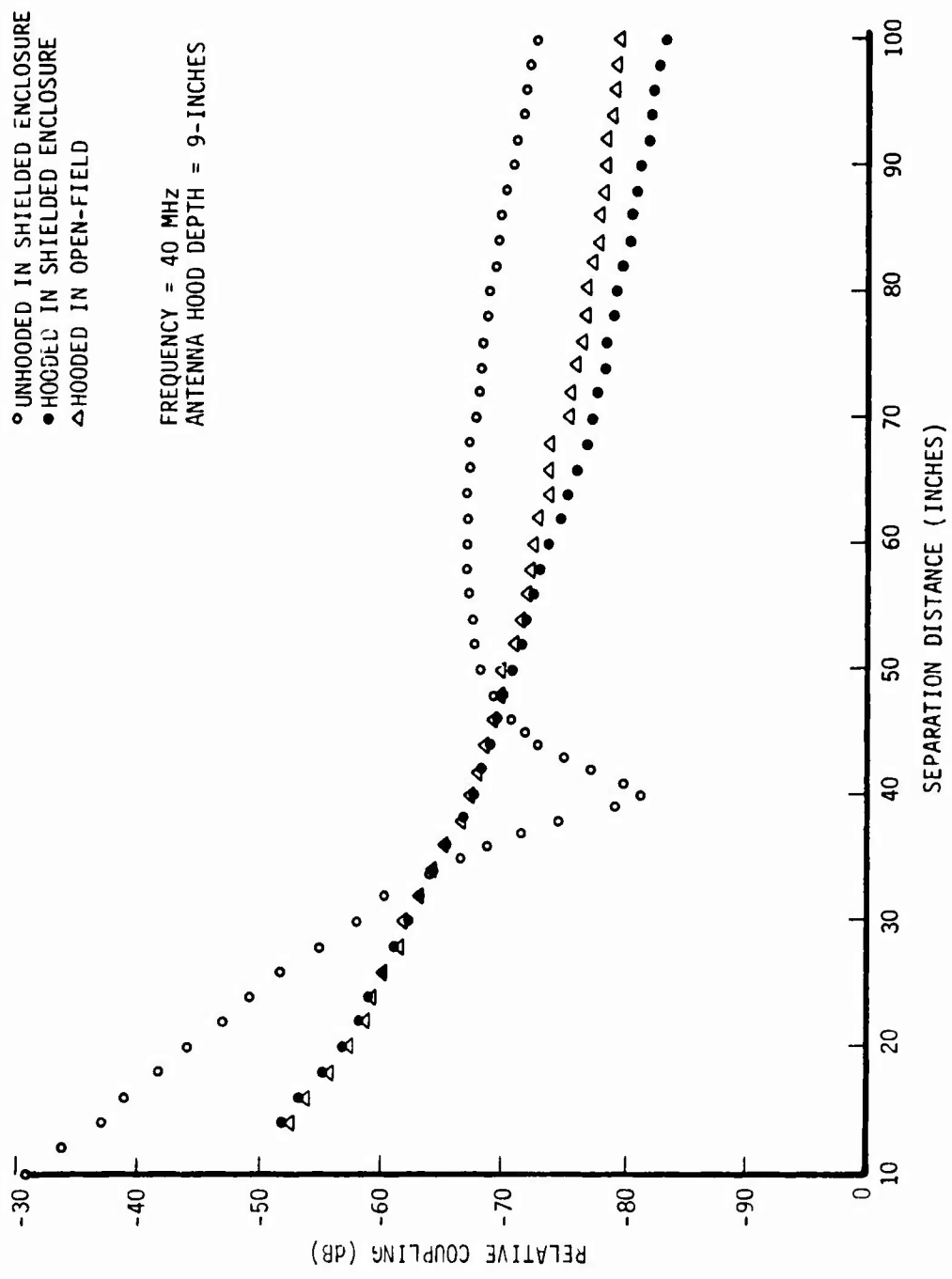

Figure 4. Relative Coupling as a Function of Antenna Separation Distance at a Frequency of 40 MHz.

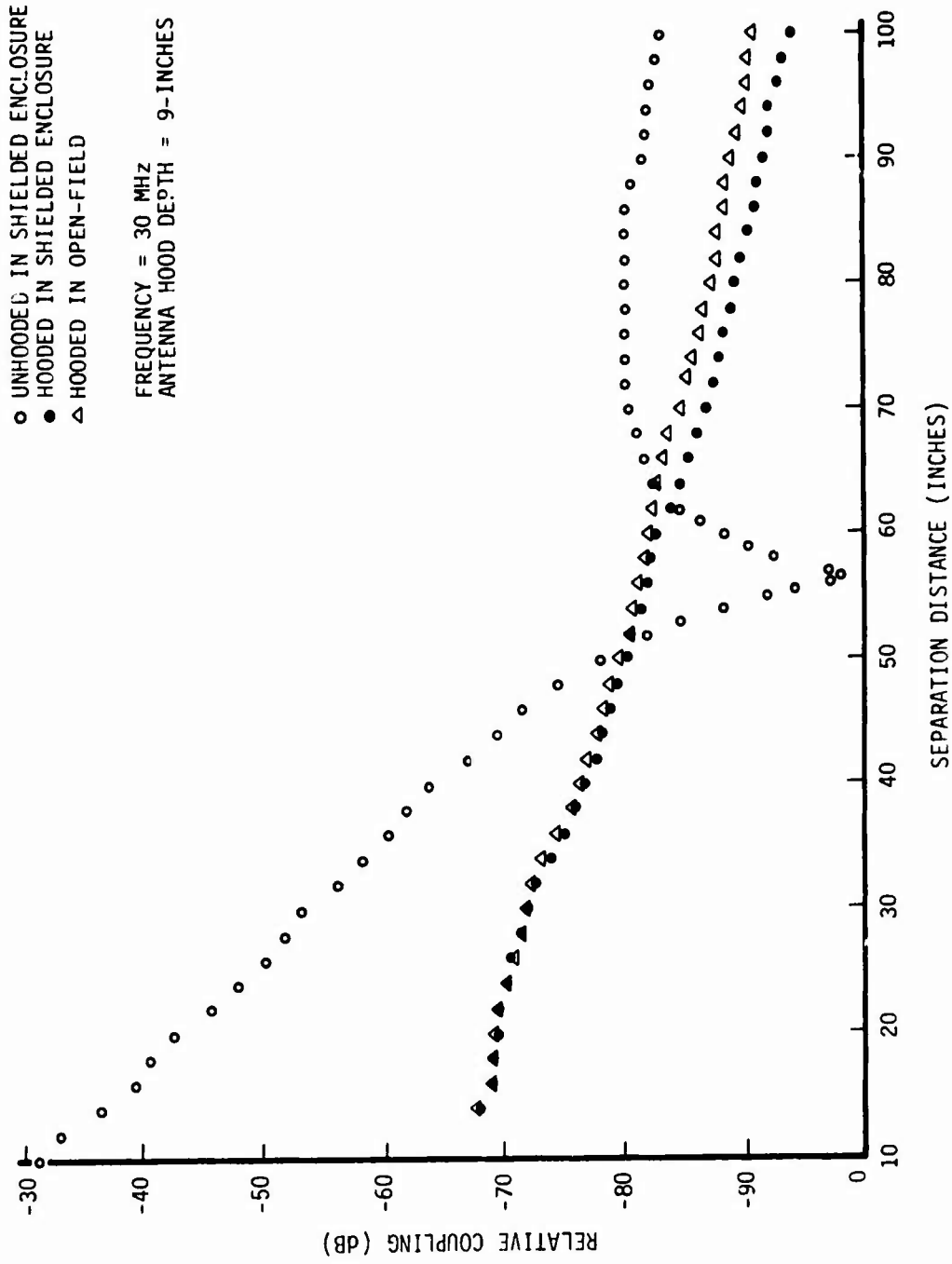

Figure 5. Relative Coupling as a Function of Antenna Separation Distance at a Frequency of 30 MHz.

While the low frequency hooded antenna exhibits little or no response to radially polarized fields, Figures 3, 4 and 5 indicate that this antenna does exhibit less gain than unhooded bow-tie antennas. Open-field coupling measurements were made as a function of the separation distance of the 30-inch bow-tie antenna and the unhooded 18-inch bow-tie antenna. The results of these measurements are shown in Figures 6, 7 and 8. The corresponding open-field coupling curves between the 30-inch bow-tie antenna and the hooded 18-inch bow-tie antenna are included in these figures for comparison.

As expected, the near-field mutual coupling between the source and probe antennas was found to be considerably altered when the probe antenna was hooded. As can be seen from Figures 6, 7 and 8 the additional coupling losses associated with the hooded probe are dependent both on separation distance and frequency. To further document the range dependence of mutual coupling in the near-field, azimuth antenna patterns were made of the response of the hooded probe antenna to the tangentially polarized electric field, E_{θ} . For these patterns a short dipole antenna was used as a radiating source. Figure 9 shows the test setup used in obtaining the patterns.

Azimuth antenna patterns of the hooded probe antenna were made at source-to-probe separation distances of 28, 36, 48, 60, 72 and 84 inches. The patterns were made at a frequency of 40 MHz with the bow-tie probe located at a 24-inch hood depth. The resulting patterns are shown in Figures 10 and 11. In order to obtain the clearest possible patterns, it was necessary to increase the power delivered to the source antenna as the source-to-probe separation distance was increased. The response level on boresight is indicated on the pattern at each separation distance. All levels are referenced to 0 dB at a 28-inch separation distance.

As Figures 10 and 11 indicate, there are several dramatic effects of separation distance on the hooded probe antenna patterns as a result of near-field mutual coupling changes between the source and hooded probe antenna. The apparent front-to-back ratio is seen to change from about 32 dB at a 28-inch separation distance to about 10 dB at 84 inches. The apparent 3 dB beamwidth changes from approximately 36 degrees at 28 inches to approximately 84 degrees at 84 inches. The word "apparent" is used advisedly in describing the front-to-back ratio and beamwidth changes. It should be recognized that the "patterns" shown in Figures 10 and 11 actually depict the near-field mutual coupling of the dipole source and the hooded probe as a function of the azimuth position of the latter. The near-field as used here implies the region less than a few wavelengths from the antenna where the induction-field and electrostatic-field are significant with respect to the radiated field. In this region the coupling between two antennas includes inductive coupling and capacitive coupling as well as the normal coupling involving the radiated field. The inductive coupling and capacitive coupling are

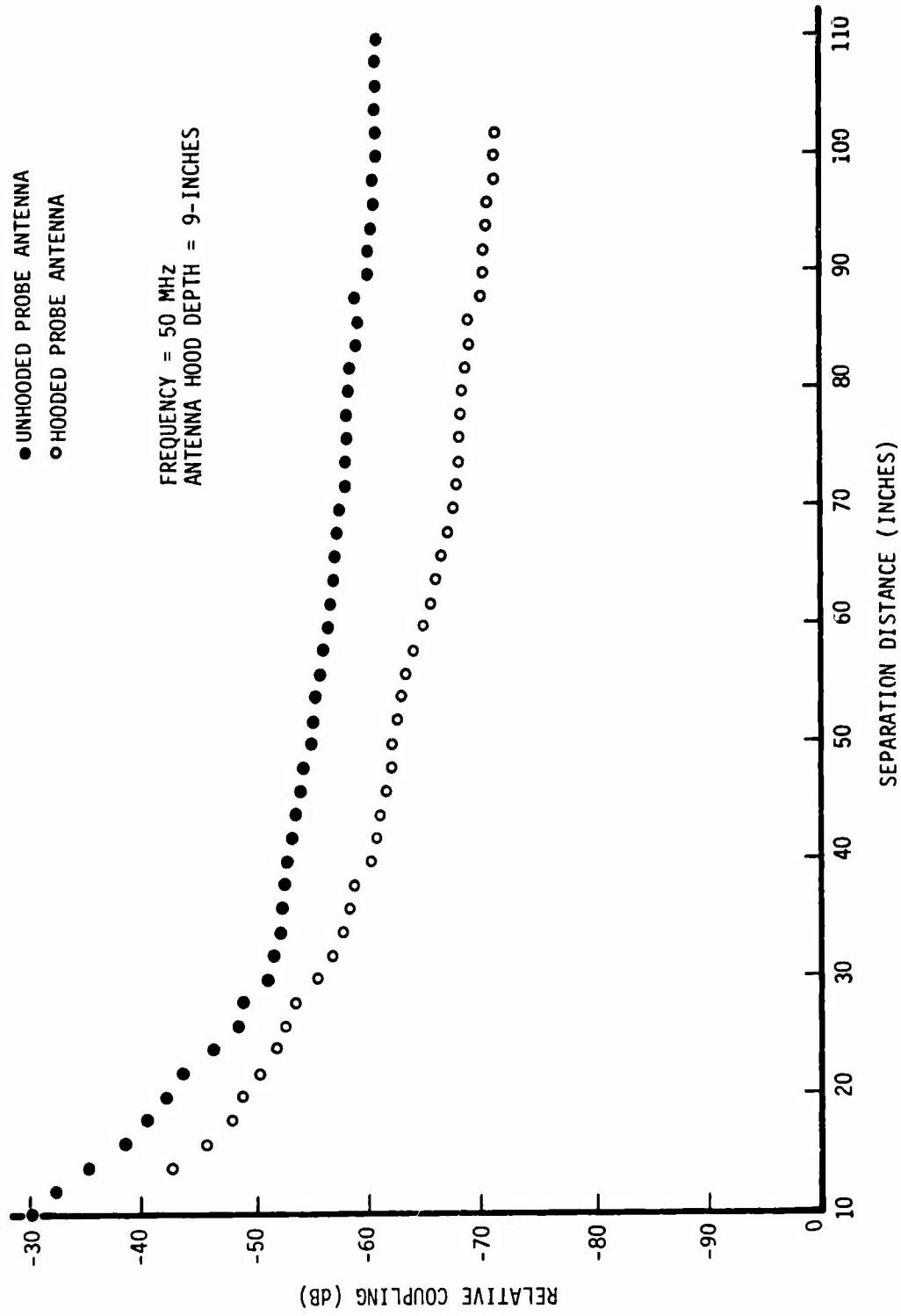

Figure 6. Open-Field Relative Coupling at 50 MHz.

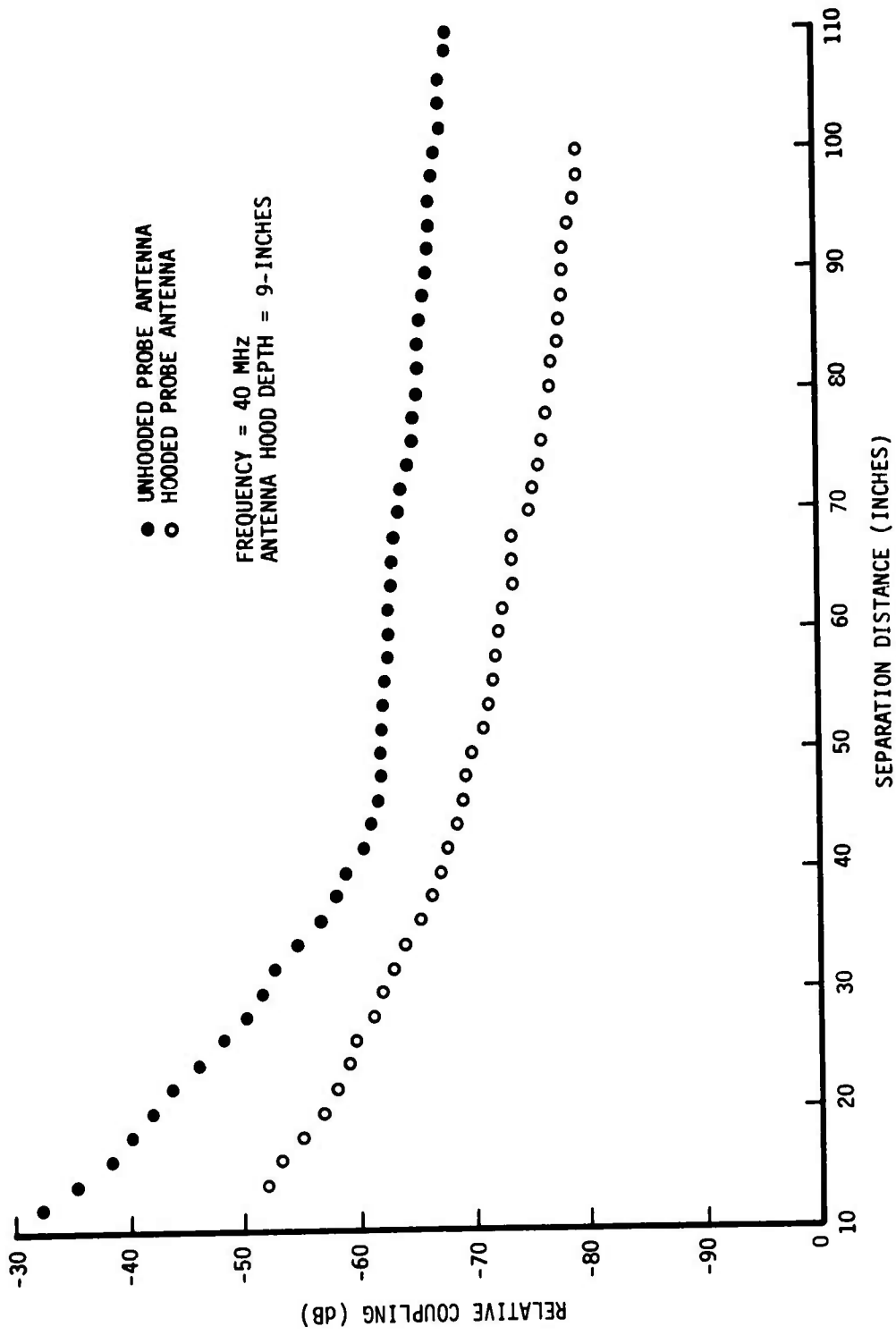

Figure 7. Open-Field Relative Coupling at 40 MHz.

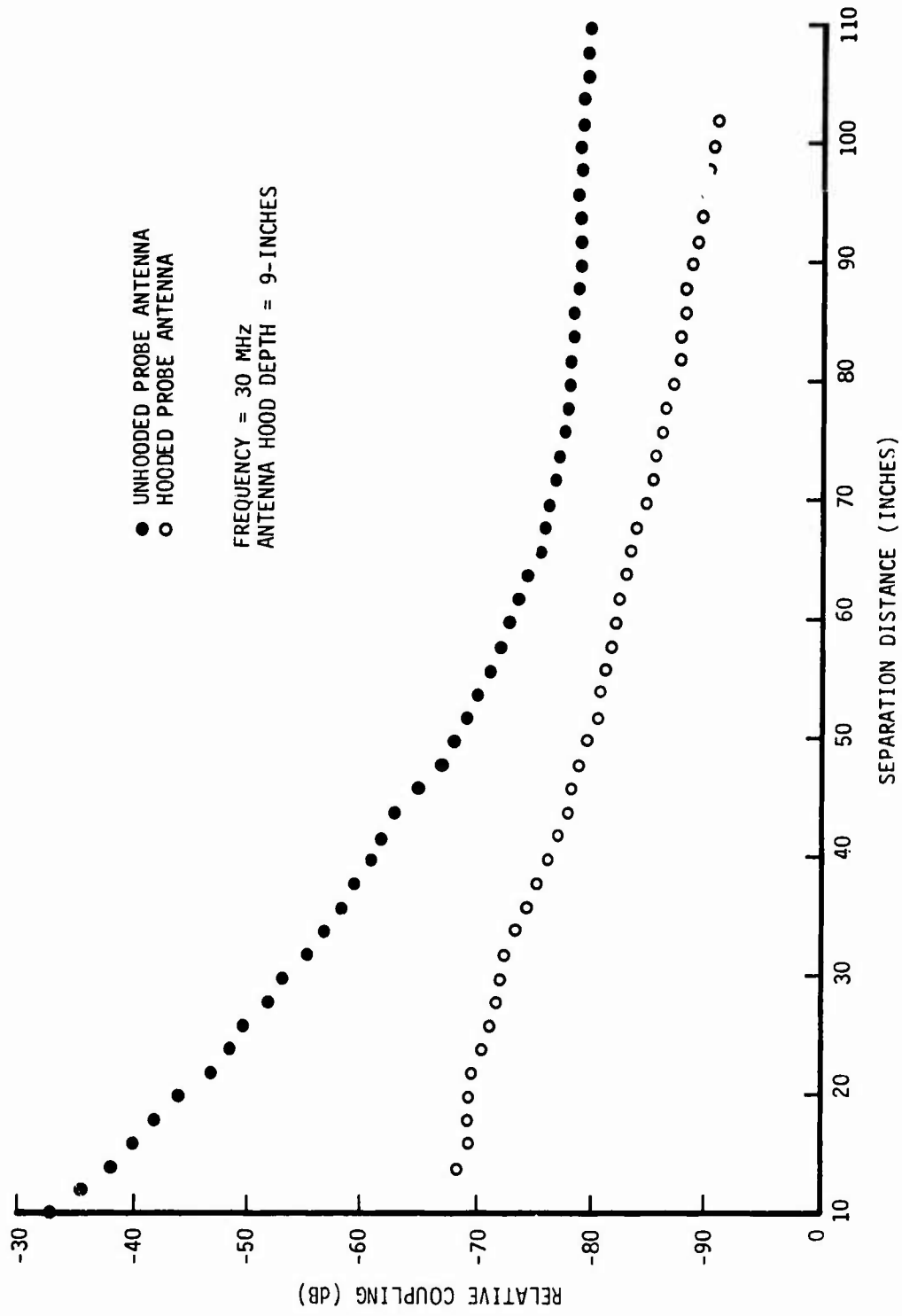

Figure 8. Open-Field Relative Coupling at 30 MHz.

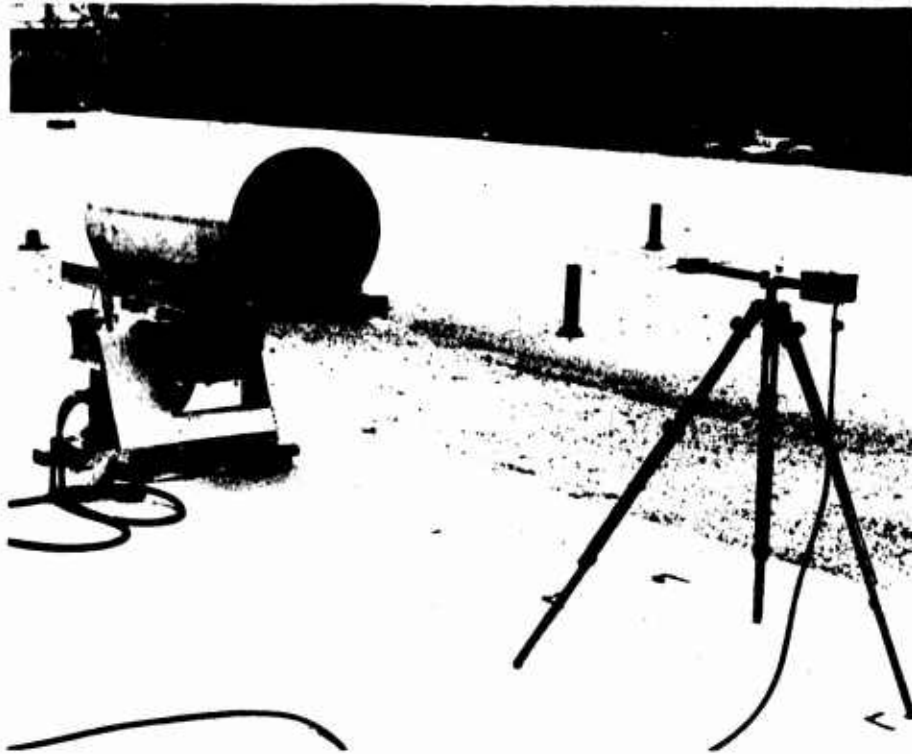

Figure 9. View of the Test Set-Up for Measuring Near-Field Mutual Coupling Patterns.

extremely sensitive to the configurations of the two antennas involved, to the spacing between the antennas and to the orientation of the two antennas with respect to each other. Hence, it is to be expected that patterns made in this region will be significantly different from far-field patterns and will be a function of the distance at which they are measured. The mutual coupling patterns shown in Figures 10 and 11 would be expected to change, for example, if a different source antenna were used in place of the short dipole shown in Figure 9.

3. Future Investigations

It has been shown that a low frequency antenna hood can be used to effectively isolate the probe antenna from the radially polarized field component propagated along a shielded enclosure wall. Low frequency hooded antenna coupling measurements in a shielded enclosure agree quite well with corresponding hooded measurements made in the open-field. However, coupling losses associated with the low

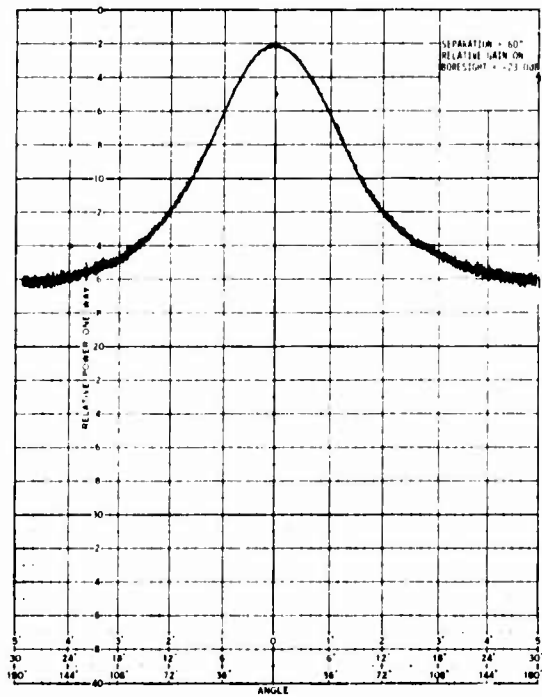
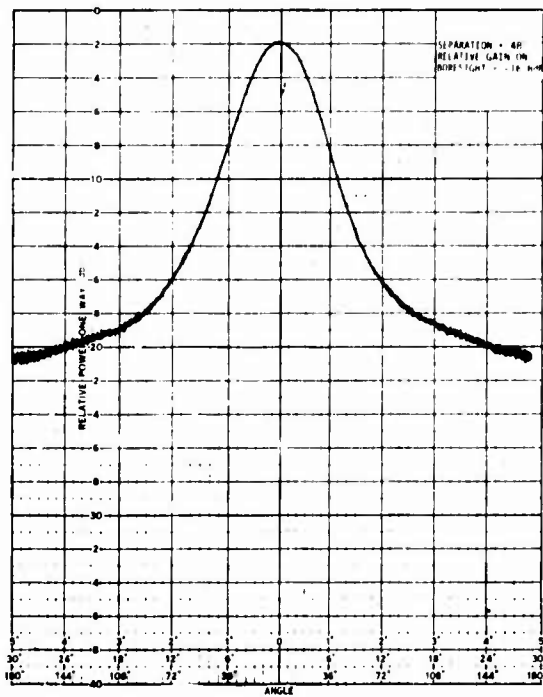
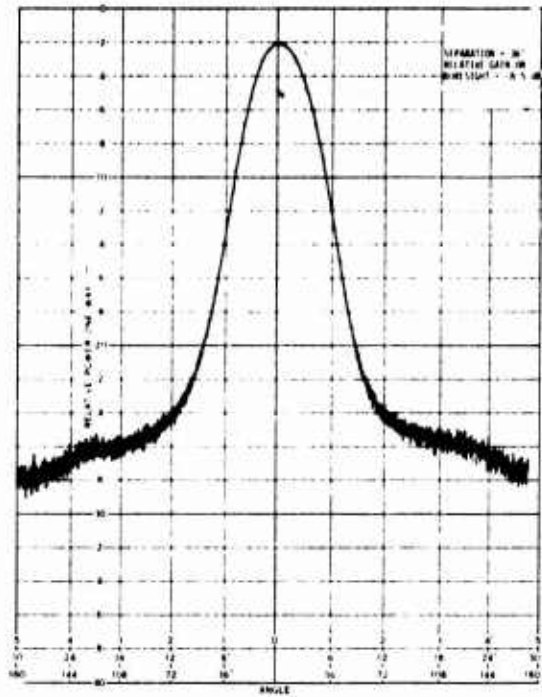
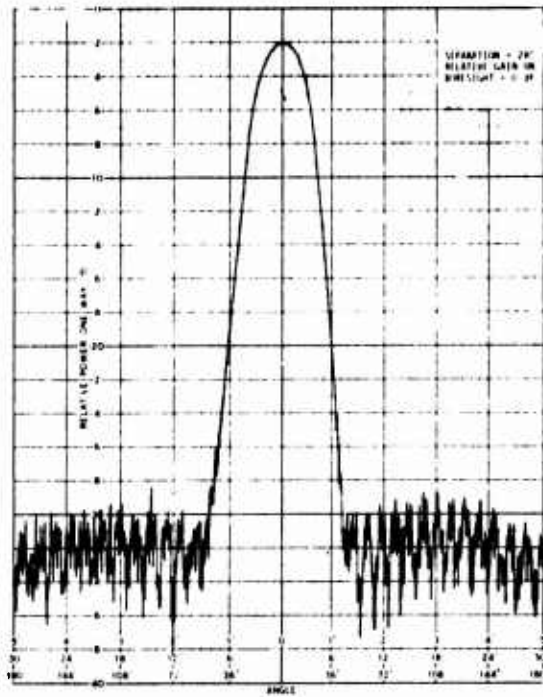

Figure 10. Near-Field Mutual Coupling Between a Dipole and Hooded Probe Antenna at Separation Distances of 28, 36, 48 and 60 Inches.

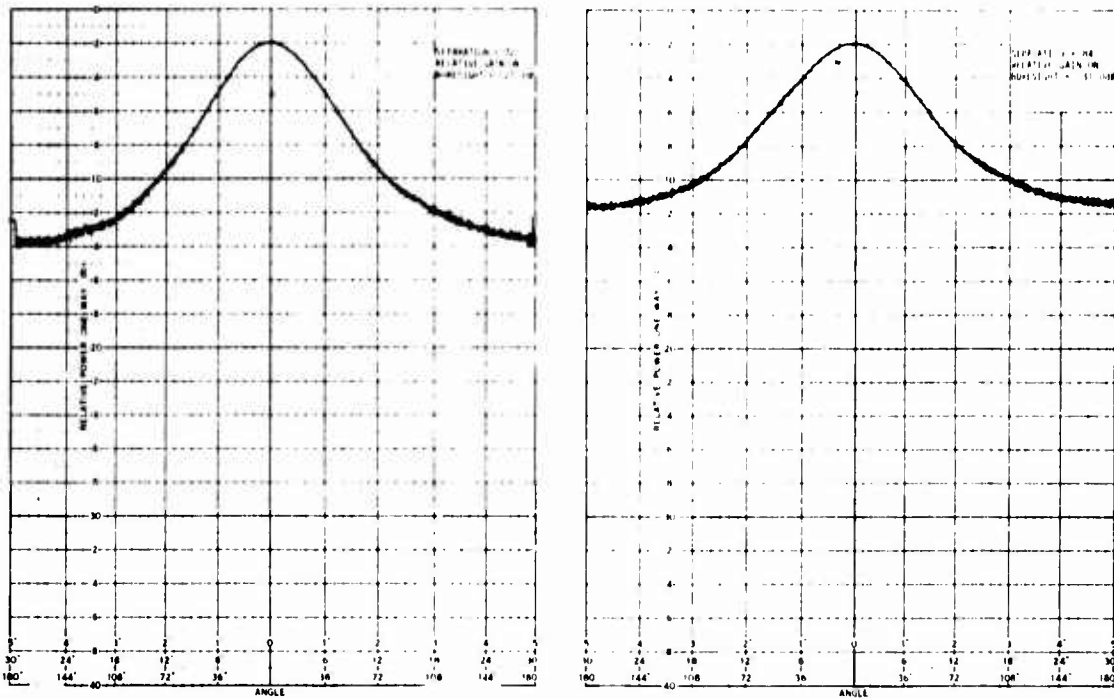

Figure 11. Near-Field Mutual Coupling Between a Dipole and Hooded Probe Antenna at Separation Distances of 72 and 84 Inches.

frequency hooded antenna are appreciable and the mutual coupling between the source and probe antenna is significantly affected by the antenna hood. The strong dependence of mutual coupling on the probe antenna hood could further complicate any future calibration of this type of antenna. Thus, while the low frequency hooded antenna does offer a solution to some of the near-field measurement problems in shielded enclosures, this solution is not without some disadvantages.

During the coming quarter alternate techniques will be investigated for minimizing the effects of the radially polarized near-field component on measurements made in shielded enclosures. It is anticipated that the investigation will include methods of preventing the radial field from propagating along the enclosure walls as well as alternate techniques to minimize probe coupling of this field from the walls.

C. Short Hooded Antennas

1. Background

A major objective of the present program is to improve the design of hooded antennas. The evaluation of the hooded antennas on previous programs revealed that the relatively long hoods utilized with these antennas were yielding more directivity than was required. In fact, at the higher frequency limits, the beamwidths of the antennas were narrower than desired. In addition, it is desirable to reduce the length of the antenna hoods in order to reduce the size, weight and cost of future hooded antennas.

An initial step in reducing the length of hooded antennas was to substitute cavity-backed spiral antennas for conical log-helix antennas as the primary feeds for hooded antennas. The cavity-backed spirals appear to exhibit all the desirable characteristics of the log-conical antennas, and in addition, are planar structures. In previous hooded antennas utilizing log-conical antennas as primary feeds, an appreciable part of the hood length was required to accommodate the length of the log-conical antenna. The substitution of cavity-backed spiral antennas allowed practically all of this hood length to be eliminated.

An adjustable-length hooded antenna was fabricated and a study was conducted to determine the performance of hooded antennas as a function of hood length. This study was described in detail in the first quarterly report. The results from this study indicated that the length of the hood could be reduced to approximately 1/3 the hood diameter and still provide a half-power beamwidth of less than 60 degrees over at least a 3:1 frequency range. The results also indicated that the beamwidths of short hooded antennas are considerably less sensitive to frequency than long hooded antennas.

To verify these results and determine the beamwidth characteristics of short hooded antennas, two experimental short hooded antennas were designed to cover the frequency ranges of 1 to 4 GHz and 3 to 12 GHz and to yield an essentially constant 50 degree beamwidth over the 1 to 12 GHz range. Details of the design, fabrication and evaluation of these antennas were presented in the second quarterly report.

The results obtained with the two experimental short hooded antennas were not as good as anticipated. The patterns obtained with the short hooded antennas were considerably wider and more sensitive to frequency than expected. It was hypothesized that the lack of success could be due to the fact that the short hooded antenna designs were based on data obtained with an adjustable-length hooded antenna in which the aperture dimension and the primary feed antenna (and hence the primary antenna pattern) were different from the final short hooded antenna configurations.

In order to obtain experimental data which are more directly applicable to the short hooded antenna designs, two additional adjustable-length hooded antennas have been fabricated. The dimensions and configurations of these antennas have been made as near as possible identical to the planned short hooded antennas. In addition, the same cavity-backed spiral antennas that were utilized in these adjustable-length hooded antennas will be used in the final short hooded antennas.

2. Adjustable-Length Hooded ASN 116A Antenna

An adjustable-length hooded antenna for a lower frequency limit of 1 GHz was designed and fabricated. The objective of this antenna is to cover the frequency range from 1 GHz to as high a frequency as possible, and over its useable frequency range, to provide a half-power beamwidth in the range from 20 to 60 degrees. A photograph of this hooded antenna is shown in Figure 12. The hood is a metal cylinder lined with Emerson and Cuming Eccosorb NZ-1 absorbing material. The outside diameter is 12 inches and the inside diameter is 10 inches. An AEL Model ASN 116A cavity-backed spiral antenna was used as the primary feed antenna for this hooded configuration. The ASN 116A antenna is designed to cover the 1 to 10 GHz frequency range. Antenna patterns for the basic unhooded antenna at 2, 3, 4, 6, 7, 8, 9 and 10 GHz are shown in Figures 13 and 14. It is apparent from the figures that the 3 dB beamwidths at the 8 test frequencies vary from 48 degrees to 103 degrees with an average half-power beamwidth of 77.6 degrees. The ASN 116A antenna and a false metal



Figure 12. Adjustable-Length Hooded ASN 116A Antenna.

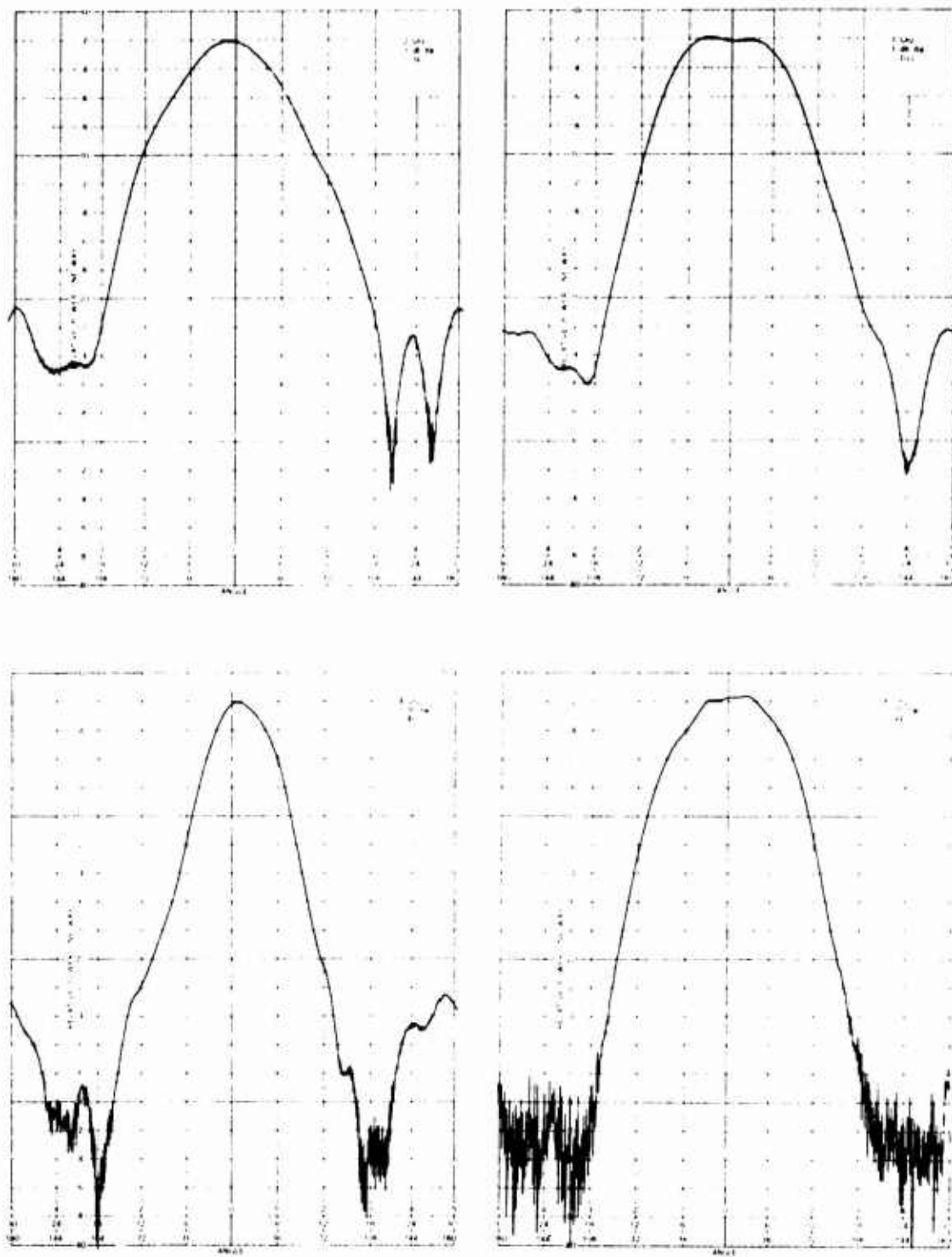

Figure 18. Antenna Patterns for 10A and 10A Antenna at 1.5, 2, 3 and 4 MHz.

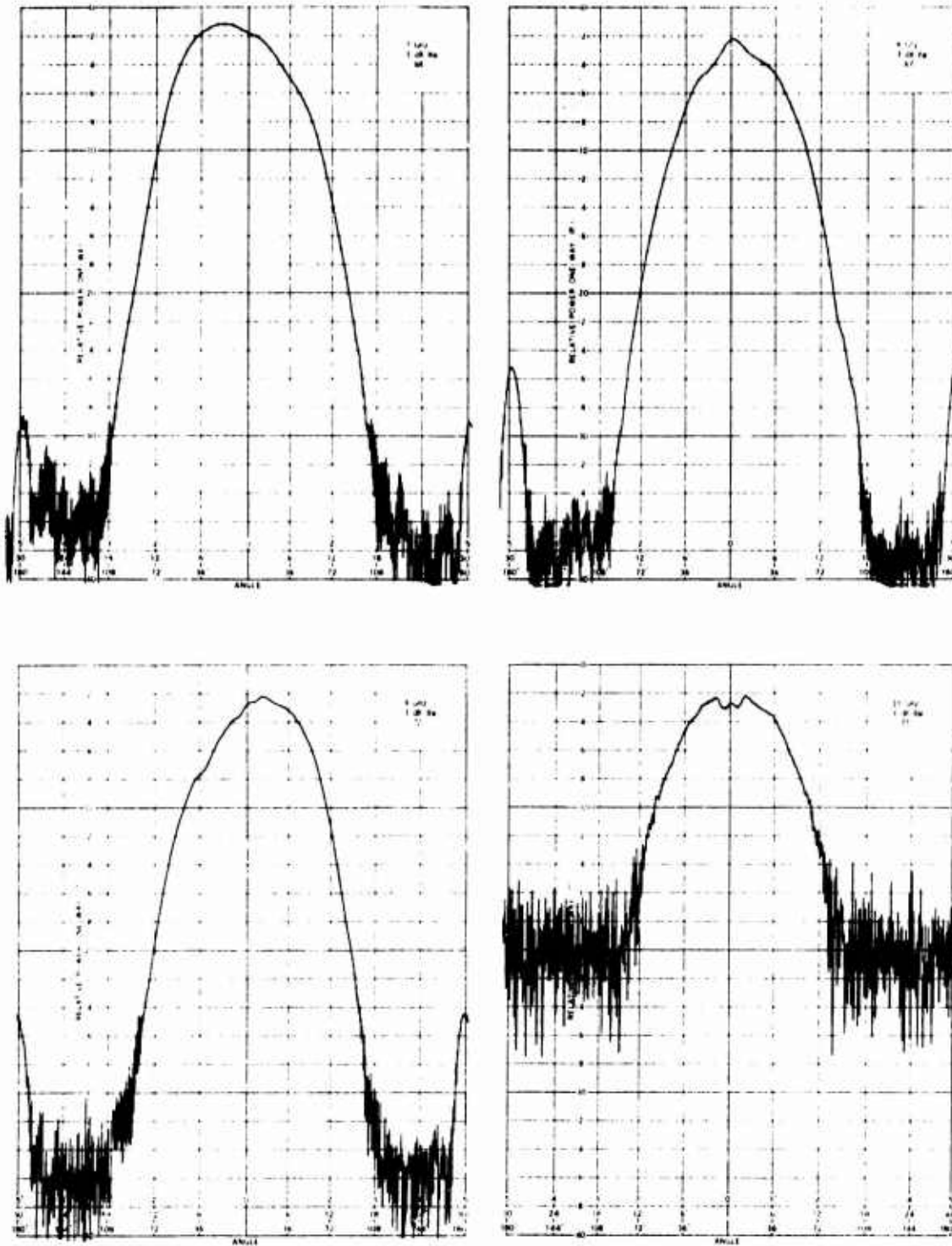

Figure 14. Antenna Patterns for Unhooded ASM 116A Antenna at 7, 8, 9 and 10 GHz.

end-plate lined with NZ-1 absorbing material were mounted on a circular piece of expanded polyethylene foam. The diameter of the foam was made so that it was a tight sliding fit to the inside of the hood, and hence, was capable of supporting the antenna and false end-plate at any location along the length of the hood. The length of the hood was made 13 inches long so that this configuration made it possible to vary the distance between the aperture of the hood and the aperture of the ASN 116A antenna from zero to 4 inches.

Antenna patterns for the hooded antenna were made at five frequencies (1, 2, 3, 4 and 5 GHz) for hood lengths of 0, 1, 2, 3, and 4 inches. The best results were obtained for a hood length of 4 inches and the antenna patterns obtained with this hood length at 1, 2, 3, and 4 GHz are shown in Figure 15. The figure shows that the half-power beamwidth obtained at 1 GHz is 72 degrees. Since an objective of the hooded antenna development program is to obtain half-power beamwidths of less than 60 degrees, this beamwidth is excessive. However, a 72-degree beamwidth was obtained for all hood lengths from zero to 4 inches at 1 GHz indicating that the beamwidth is independent of hood length at this frequency. Thus it was concluded that the aperture of the hood is not sufficiently large to provide the desired directivity at this frequency. Half-power beamwidths of 42 degrees and 45 degrees were obtained at 2 and 3 GHz, respectively. These are well within the desired beamwidth range of 20 to 60 degrees, and hence, indicate that the performance of the short hooded antenna is satisfactory in this frequency range. The antenna pattern obtained at 4 GHz shows that significant beam-splitting occurs at this frequency. Patterns at higher frequencies indicate that the beam-splitting becomes more severe with increasing frequency.

The results from this study indicate that (1) in order to operate down to 1 GHz, the aperture of the short hooded antenna will have to be increased slightly, possibly to an inside diameter of 12 inches, (2) the useable frequency range of a short hooded ASN 116A hooded antenna will probably cover the 1 to 3 GHz range and (3) the optimum hood length for a 1 to 3 GHz short hooded antenna is 4 inches.

3. Adjustable-Length Hooded ASN 111A Antenna

An adjustable-length hooded antenna for a lower frequency limit of 3 GHz was designed and fabricated. The objective for this antenna is to cover the frequency range from 3 GHz to as high a frequency as possible, and over its useable frequency range, to provide a half-power beamwidth in the range from 20 to 60 degrees. A photograph of this hooded antenna is shown in Figure 16. The hood is the same configuration as the ASN 116A hooded antenna, the difference being the outside diameter of this hood is 6 inches and the inside diameter is 4 inches. An AEL Model ASN 111A cavity-backed spiral antenna was used as the primary feed antenna for this hooded configuration. The

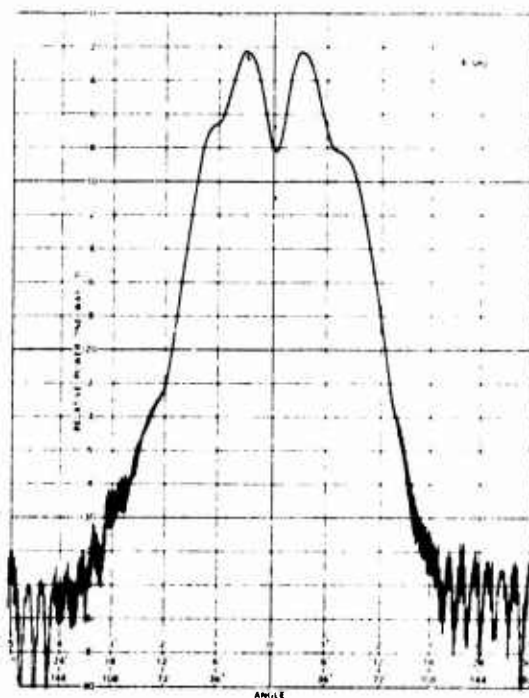
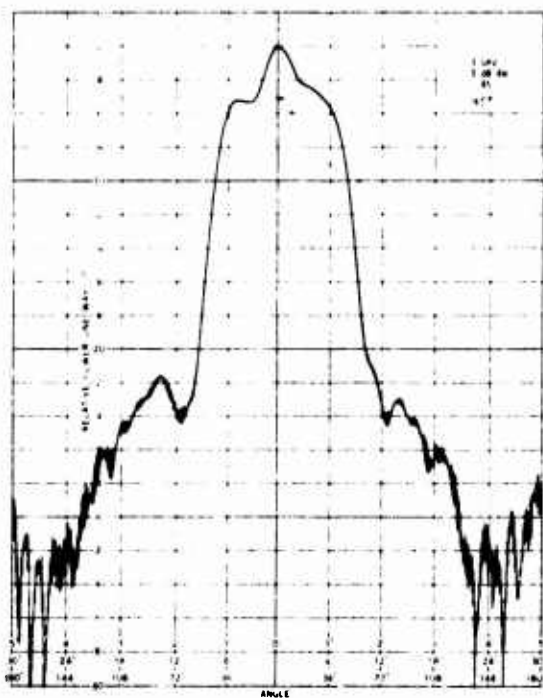
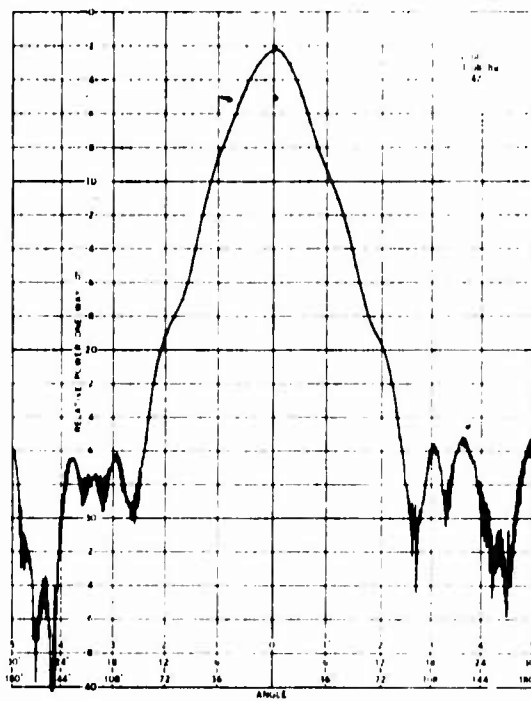
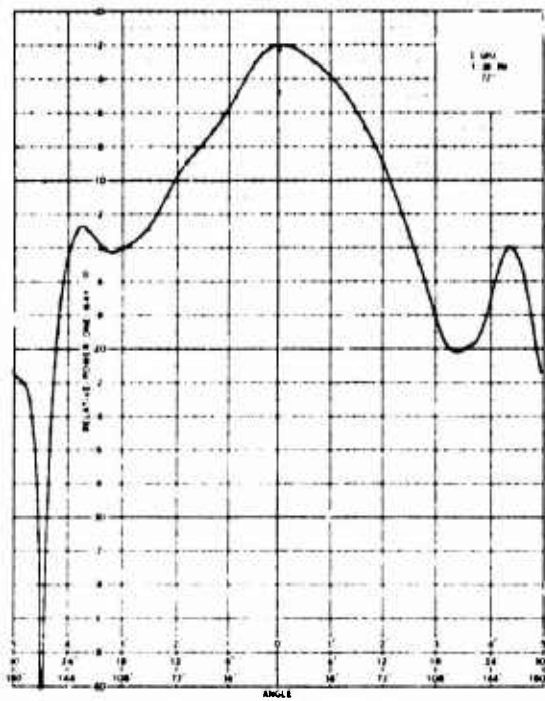

Figure 15. Antenna Patterns for Hooded ASN 116A Antenna at 1, 2, 3 and 4 GHz.

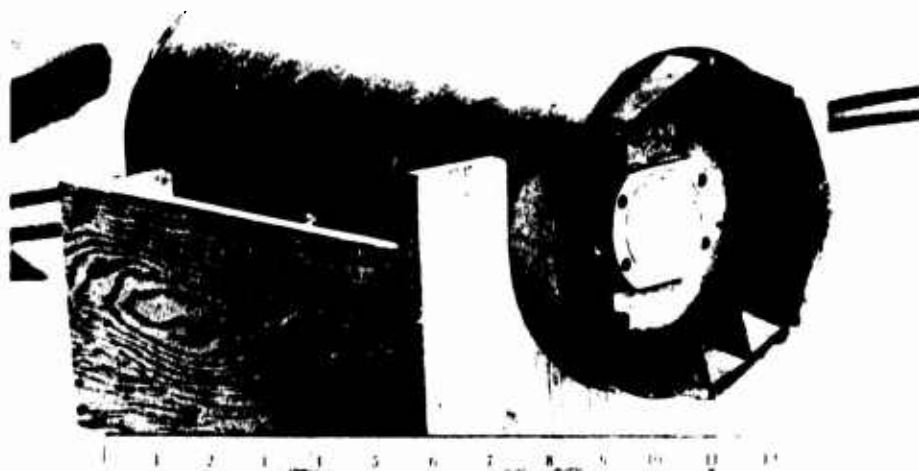

Figure 16. Adjustable-Length Hooded ASN 111A Antenna.

ASN 111A antenna is designed to cover the 3 to 12 GHz frequency range. Antenna patterns for the basic unhooded antenna at 4, 6, 8 and 10 GHz are shown in Figure 17. It is apparent from the figure that the 3 dB beamwidths at the four test frequencies vary from 54 degrees to 84 degrees. The ASN 111A antenna and a false end-plate covered with NZ-1 material were mounted in the hood in the same manner as the ASN 116A antenna so that the antenna could be positioned at any location along the length of the hood. The length of the hood was made 13.5 inches so that the aperture of the ASN 111A antenna could be located at any distance from zero to 4 inches from the aperture of the hood.

Antenna patterns for the hooded antenna were made at six frequencies (3, 4, 5, 6, 7 and 8.5 GHz) for hood lengths of 0, 1, 2, 3 and 4 inches. The best results were obtained for a hood length of 2 inches, and the antenna patterns obtained with this hood length at the six test frequencies are shown in Figures 18 and 19. It is apparent from the antenna patterns that the half-power beamwidth of the hooded antenna over the frequency range from 3 to 8.5 GHz remains in the range from 28 to 60 degrees.

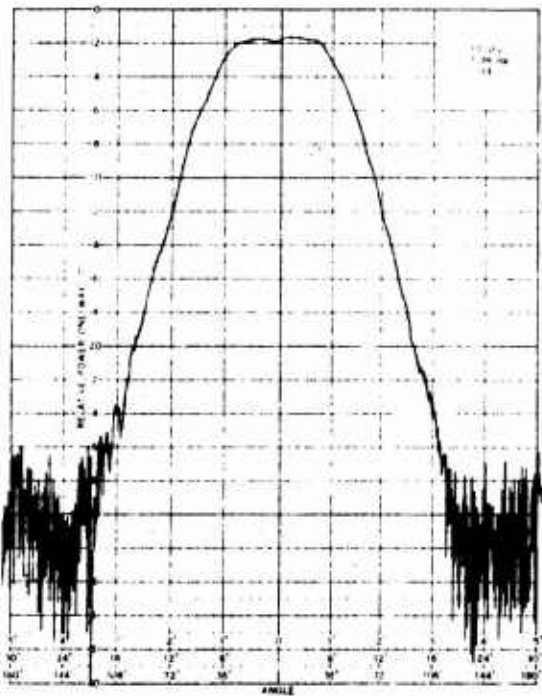
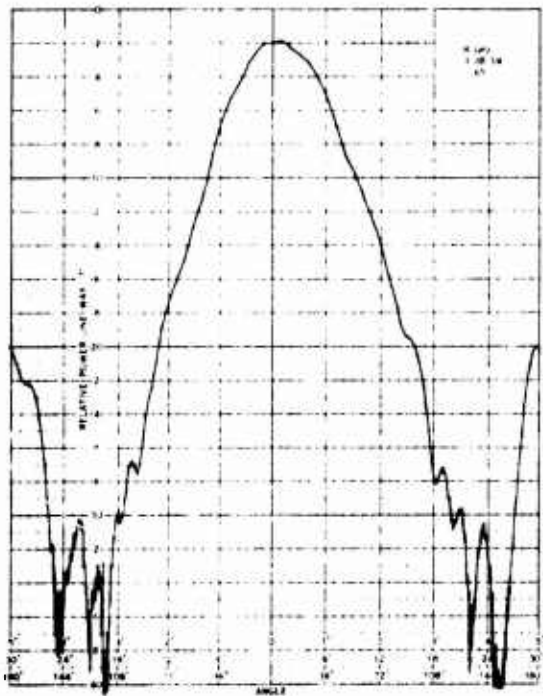
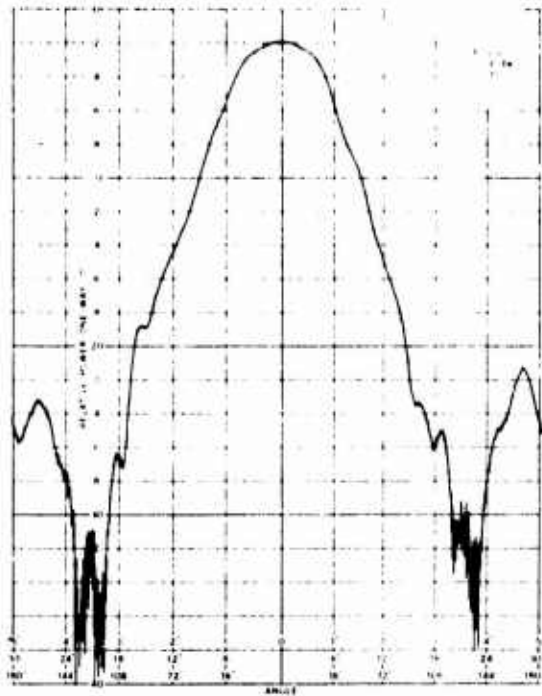
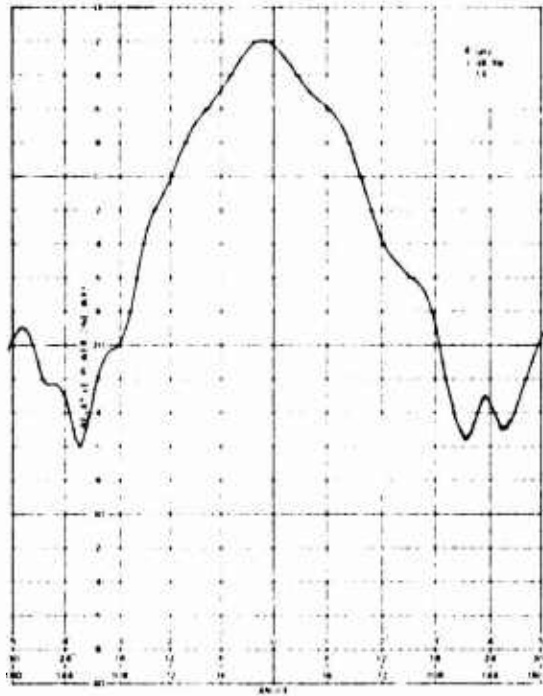

Figure 17. Antenna patterns for Unicoosa ASK 111A Antenna at 5, 6, 7 and 10 GHz.

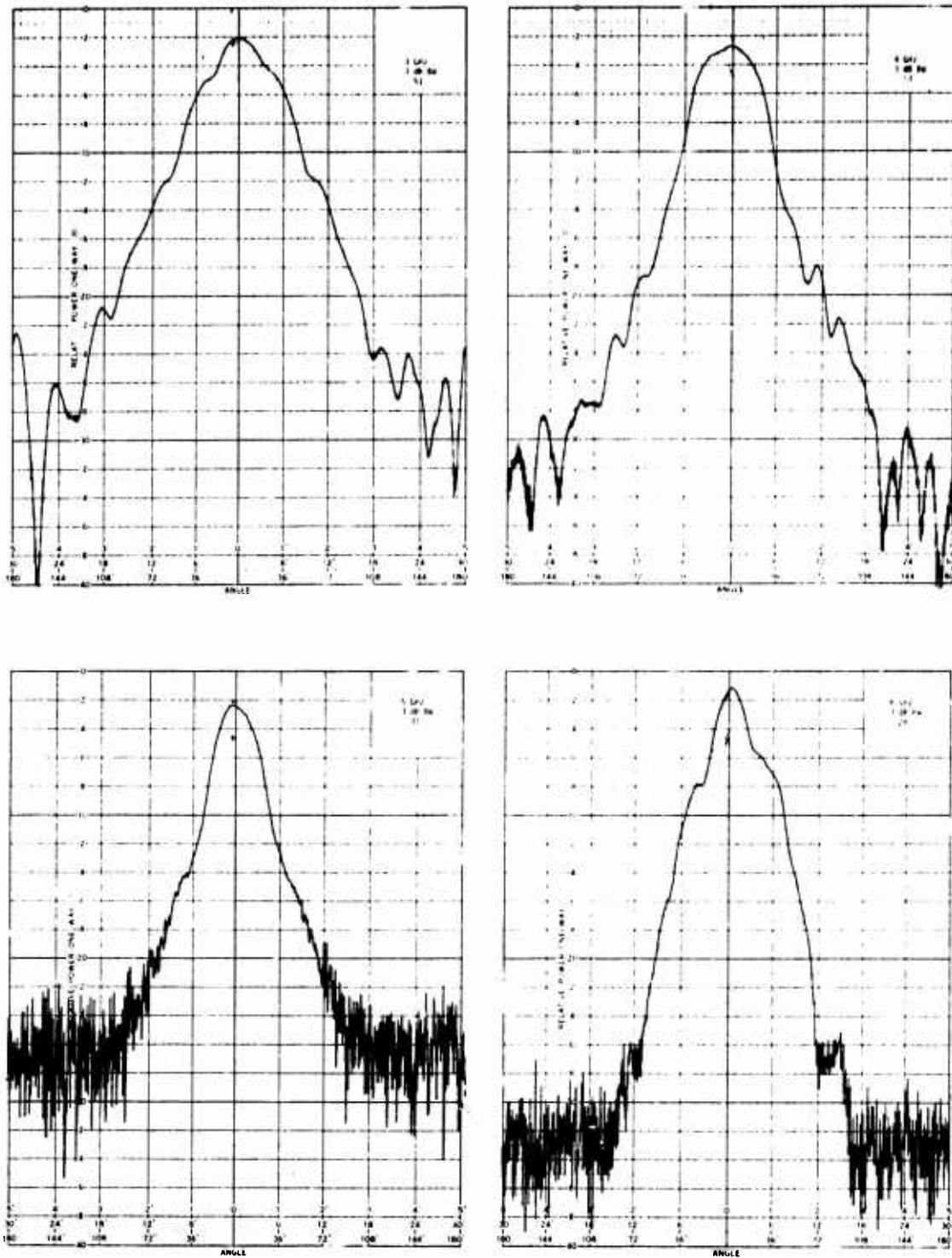

Figure 18. Antenna Patterns for Hooded ASI 111A Antenna at 3, 4, 5 and 6 GHz.

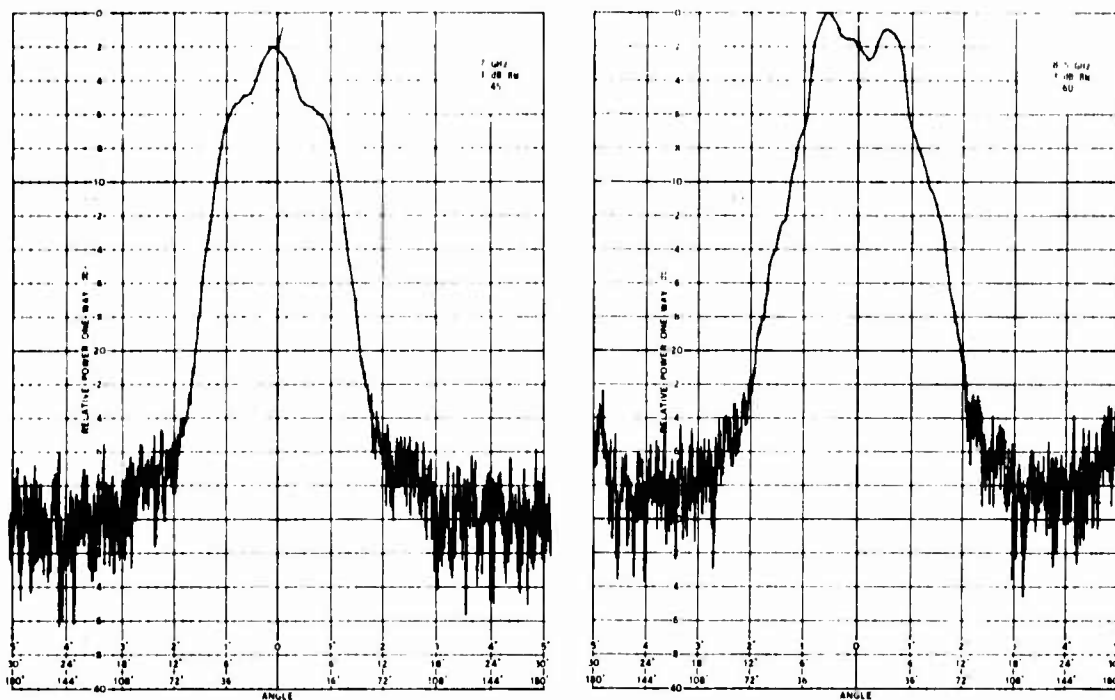

Figure 19. Antenna Patterns for Hooded ASN 111A Antenna at 7 and 8.5 GHz.

The results from this study indicate that a short hooded antenna with a 4-inch aperture and 2-inch hood length will operate satisfactorily over the frequency range from 3 to 8 GHz.

4. Future Hooded Antenna Investigations

Results from the programs described above indicate that the 1 to 12 GHz frequency range can be covered with three short hooded antennas. The measured data indicate that a 4-inch long hooded antenna with a 12-inch inside diameter aperture will operate satisfactorily over the 1 to 3 GHz frequency range and a 2-inch long hooded antenna with a 4-inch inside diameter aperture will operate satisfactorily over the 3 to 8 GHz range. It is anticipated that a 1-inch long hooded antenna with a 2-inch inside diameter aperture will operate satisfactorily over the 8 to 12 GHz frequency range. A set of three short hooded antennas having these parameters will be fabricated and tested during the next quarter.

II. SUMMARY

An experimental study was performed during this reporting period to test the concept that an antenna hood could sufficiently isolate a probe antenna from near-field components propagated on the walls of a shielded enclosure to eliminate coupling variations in shielded enclosures below 100 MHz. The results from this experimental program show that a low frequency antenna hood can effectively isolate the probe antenna from the enclosure walls. However, insertion loss and calibration difficulties associated with the low frequency hooded antenna indicate that this solution is not without some disadvantages. During the next quarter, alternate techniques will be investigated for minimizing the effects of near-field components on measurements made in shielded enclosures. This investigation will include methods of preventing the radial field components from propagating along the enclosure walls as well as alternate techniques to minimize probe coupling of this field from the walls.

Two adjustable-length hooded antennas were fabricated and tested to obtain experimental data which are more directly applicable to high frequency short hooded antenna designs. Results from this measurement program indicate that three short hooded antennas will be required to cover the 1 to 12 GHz frequency range. A set of three short hooded antennas to cover the 1 to 12 GHz range will be fabricated and tested during the next quarter.

III. LITERATURE CITED

1. W. R. Free, "Electromagnetic Interference Measurement Methodology, Communication Equipment," Quarterly Report No. 1, Georgia Tech, Contract DAAB07-68-C-0189, U. S. Army ECOM, August 1968.
2. W. R. Free, et al., "Electromagnetic Interference Measurement Methodology, Communication Equipment," Quarterly Report No. 2, Georgia Tech, Contract DAAB07-68-C-0189, U. S. Army ECOM, October 1968.
3. W. R. Free, et al., "Compact Chamber for Impedance and Power Testing of VHF Whip Antennas," Final Report, Georgia Tech, Contract DAAB07-67-C-0575, U. S. Army ECOM, October 1968.

Security Classification

DOCUMENT CONTROL DATA - R&D		
<small>(Security classification of title, body of abstract and indexing annotation must be entered when the overall report is classified)</small>		
1 ORIGINATING ACTIVITY (Corporate author)		2a REPORT SECURITY CLASSIFICATION
Georgia Institute of Technology, Atlanta, Georgia		Unclassified
		2b GROUP
3 REPORT TITLE		
ELECTROMAGNETIC INTERFERENCE MEASUREMENT METHODOLOGY, COMMUNICATION EQUIPMENT		
4 DESCRIPTIVE NOTES (Type of report and inclusive dates)		
Quarterly Report No. 3, 1 August 1968 to 31 October 1968		
5 AUTHOR(S) (Last name, first name, initial)		
Free, William R. and Stuckey, Charles W.		
6 REPORT DATE	7a TOTAL NO OF PAGES	7b NO OF REFS
March 1969	29	3
8a CONTRACT OR GRANT NO	9a ORIGINATOR'S REPORT NUMBER(S)	
DAAE07-68-C-0189	A-1075-3	
b PROJECT NO	9b OTHER REPORT NO(S) (Any other numbers that may be assigned this report)	
1H6 20501 D449 0156	ECOM-0189-3	
c		
d		
10 AVAILABILITY/LIMITATION NOTICES		
This document has been approved for public release and sale; its distribution is unlimited.		
11 SUPPLEMENTARY NOTES	12 SPONSORING MILITARY ACTIVITY	
Radio Frequency Interference Communications	U. S. Army Electronics Command Fort Monmouth, New Jersey 07703	
13 ABSTRACT		
<p>Theoretical and experimental investigations directed toward the development of improved test techniques and procedures for performing radiated measurements in shielded enclosures have continued during this reporting period.</p> <p>Results from previous studies indicate that the coupling variations which occur in shielded enclosures at frequencies below 100 MHz are due to near-field radially-polarized electric field components which are propagated along the walls of the enclosure. An experimental study was performed during this reporting period to test the concept that an antenna hood could isolate a probe antenna from these sidewall-propagated, near-field components. The results from this experimental program show that a low frequency antenna hood can be used to effectively isolate the probe antenna from the enclosure walls. However, insertion loss and calibration difficulties associated with the low frequency hooded antenna indicate that this solution is not without some disadvantages.</p> <p>In order to obtain experimental data which are more directly applicable to high frequency short hooded antenna designs, two adjustable-length hooded antennas were fabricated and tested. Results from this measurement program indicate that a hooded antenna approximately 4-inches long will operate satisfactorily over the 1 to 3 GHz frequency range, a 2-inch long hooded antenna will operate satisfactorily over the 3 to 8 GHz frequency range and a third shorter hooded antenna will be required to cover the 8 to 12 GHz frequency range.</p>		

DD FORM 1473
1 JAN 64

Security Classification

Security Classification

14. KEY WORDS	LINK A		LINK B		LINK C	
	ROLE	WT	ROLE	WT	ROLE	WT
Electromagnetic Interference Measurement Methods Cavity-Backed Spiral Antennas Antennas Shielded Enclosures Near-Field Antenna Theory						

INSTRUCTIONS

1. **ORIGINATING ACTIVITY:** Enter the name and address of the contractor, subcontractor, grantee, Department of Defense activity or other organization (*corporate author*) issuing the report.
- 2a. **REPORT SECURITY CLASSIFICATION:** Enter the overall security classification of the report. Indicate whether "Restricted Data" is included. Marking is to be in accordance with appropriate security regulations.
- 2b. **GROUP:** Automatic downgrading is specified in DoD Directive 5200.10 and Armed Forces Industrial Manual. Enter the group number. Also, when applicable, show that optional markings have been used for Group 3 and Group 4 as authorized.
3. **REPORT TITLE:** Enter the complete report title in all capital letters. Titles in all cases should be unclassified. If a meaningful title cannot be selected without classification, show title classification in all capitals in parenthesis immediately following the title.
4. **DESCRIPTIVE NOTES:** If appropriate, enter the type of report, e.g., interim, progress, summary, annual, or final. Give the inclusive dates when a specific reporting period is covered.
5. **AUTHOR(S):** Enter the name(s) of author(s) as shown on or in the report. Enter last name, first name, middle initial. If military, show rank and branch of service. The name of the principal author is an absolute minimum requirement.
6. **REPORT DATE:** Enter the date of the report as day, month, year, or month, year. If more than one date appears on the report, use date of publication.
- 7a. **TOTAL NUMBER OF PAGES:** The total page count should follow normal pagination procedures, i.e., enter the number of pages containing information.
- 7b. **NUMBER OF REFERENCES:** Enter the total number of references cited in the report.
- 8a. **CONTRACT OR GRANT NUMBER:** If appropriate, enter the applicable number of the contract or grant under which the report was written.
- 8b, 8c, & 8d. **PROJECT NUMBER:** Enter the appropriate military department identification, such as project number, subproject number, system numbers, task number, etc.
- 9a. **ORIGINATOR'S REPORT NUMBER(S):** Enter the official report number by which the document will be identified and controlled by the originating activity. This number must be unique to this report.
- 9b. **OTHER REPORT NUMBER(S):** If the report has been assigned any other report numbers (*either by the originator or by the sponsor*), also enter this number(s).
10. **AVAILABILITY/LIMITATION NOTICES:** Enter any limitations on further dissemination of the report, other than those

imposed by security classification, using standard statements such as:

- (1) "Qualified requesters may obtain copies of this report from DDC."
- (2) "Foreign announcement and dissemination of this report by DDC is not authorized."
- (3) "U. S. Government agencies may obtain copies of this report directly from DDC. Other qualified DDC users shall request through _____."
- (4) "U. S. military agencies may obtain copies of this report directly from DDC. Other qualified users shall request through _____."
- (5) "All distribution of this report is controlled. Qualified DDC users shall request through _____."

If the report has been furnished to the Office of Technical Services, Department of Commerce, for sale to the public, indicate this fact and enter the price, if known.

11. **SUPPLEMENTARY NOTES:** Use for additional explanatory notes.

12. **SPONSORING MILITARY ACTIVITY:** Enter the name of the departmental project office or laboratory sponsoring (*paying for*) the research and development. Include address.

13. **ABSTRACT:** Enter an abstract giving a brief and factual summary of the document indicative of the report, even though it may also appear elsewhere in the body of the technical report. If additional space is required, a continuation sheet shall be attached.

It is highly desirable that the abstract of classified reports be unclassified. Each paragraph of the abstract shall end with an indication of the military security classification of the information in the paragraph, represented as (TS), (S), (C), or (U).

There is no limitation on the length of the abstract. However, the suggested length is from 150 to 225 words.

14. **KEY WORDS:** Key words are technically meaningful terms or short phrases that characterize a report and may be used as index entries for cataloging the report. Key words must be selected so that no security classification is required. Identifiers, such as equipment model designation, trade name, military project code name, geographic location, may be used as key words but will be followed by an indication of technical context. The assignment of links, roles, and weights is optional.