

AD 688165

AD

**USAAVLABS TECHNICAL REPORT 68-82**

**DEVELOPMENT OF A  
CRASH-RESISTANT FLAMMABLE FLUIDS  
SYSTEM FOR THE UH-1A HELICOPTER**

By

**S. Harry Robertson**

D D C  
RECEIVED  
JUN 3 1969  
REGULATED  
B

RE

January 1969

**U. S. ARMY AVIATION MATERIEL LABORATORIES  
FORT EUSTIS, VIRGINIA**

**CONTRACT DAAJ02-67-C-0004  
DYNAMIC SCIENCE (THE AvSer FACILITY)  
A DIVISION OF MARSHALL INDUSTRIES  
PHOENIX, ARIZONA**

*This document has been approved  
for public release and sale; its  
distribution is unlimited.*



Reproduced by the  
**CLEARINGHOUSE**  
for Federal Scientific & Technical  
Information Springfield Va. 22151

164

### Disclaimers

The findings in this report are not to be construed as an official Department of the Army position unless so designated by other authorized documents.

When Government drawings, specifications, or other data are used for any purpose other than in connection with a definitely related Government procurement operation, the United States Government thereby incurs no responsibility nor any obligation whatsoever; and the fact that the Government may have formulated, furnished, or in any way supplied the said drawings, specifications, or other data is not to be regarded by implication or otherwise as in any manner licensing the holder or any other person or corporation, or conveying any rights or permission, to manufacture, use, or sell any patented invention that may in any way be related thereto.

Trade names cited in this report do not constitute an official endorsement or approval of the use of such commercial hardware or software.

### Disposition Instructions

Destroy this report when no longer needed. Do not return it to the originator.

COPIES FOR		
DTI	WHITE SECTION	<input type="checkbox"/>
DC	DIFF SECTION	<input type="checkbox"/>
ANNOUNCED		<input type="checkbox"/>
SIGNATURE		
.....		
DISTRIBUTION/AVAILABILITY CODES		
DIST.	AVAIL.	and/or SPECIAL
/		



DEPARTMENT OF THE ARMY  
U. S. ARMY AVIATION MATERIEL LABORATORIES  
FORT EUSTIS, VIRGINIA 23604

This report was prepared by Dynamic Science, a Division of Marshall Industries, Phoenix, Arizona, under the terms of Contract DAAJ02-67-C-0004.

The report contains the results of a dynamic crash test of a UH-1A helicopter conducted in an effort to determine the effectiveness of a complete crash-resistant fuel, oil, and electrical system under severe accident conditions. The report also contains design and test data on each of the crashworthy components installed in the aircraft.

Project 1F162203A529  
Contract DAAJ02-67-C-0004  
USAAVLABS Technical Report 68-82  
January 1969

DEVELOPMENT OF A  
CRASH-RESISTANT FLAMMABLE FLUIDS  
SYSTEM FOR THE UH-1A HELICOPTER

Dynamic Science 68-6

By

S. Harry Robertson

Prepared by

Dynamic Science (The AvSER Facility)  
A Division of Marshall Industries  
Phoenix, Arizona

for

U. S. ARMY AVIATION MATERIEL LABORATORIES  
FORT EUSTIS, VIRGINIA

**This report has been approved  
for public release and sale; its  
distribution is unlimited.**

## SUMMARY

A crash test of a UH-1A helicopter was conducted to determine the effectiveness of a complete crash-resistant fuel, oil, and electrical system under severe accident conditions. The individual systems employed in the aircraft were developed over the past several years and had been tested in separate experiments in previous crash tests. This was the first test of a complete system.

The system included: (1) special crash-resistant fuel tanks and oil tank, (2) flexible fuel and oil lines in those areas in which rigid metal fuel lines characteristically fail in accidents, and (3) self-sealing breakaway valves and combustible fluid-line disconnects at strategic locations as necessary to allow for relative displacement of key aircraft components.

The aircraft was flown by remote control during the crash test, in which all fuel tanks were filled with emulsified JP-4 and the aircraft engine was operating on emulsified JP-4. Prior to the crash test, a program was conducted to investigate the problems associated with engine operation on emulsified JP-4. Manned test flights and calibration flights, operating on the emulsion, had been successfully accomplished.

The test results indicated that crashworthiness had been achieved. No fuel or oil was spilled from any of the systems, even though many of them were displaced considerable distances. All of the crash-resistant systems that were called upon to function did so. Many others, not called upon, remained intact and appeared to be in operational condition. All of the fuel tanks and self-sealing valves were salvaged for future tests, even though the crash test was extremely severe.

TABLE OF CONTENTS

	<u>Page</u>
SUMMARY . . . . .	iii
LIST OF ILLUSTRATIONS . . . . .	viii
LIST OF TABLES . . . . .	xv
INTRODUCTION . . . . .	1
APPROACH TO THE PROBLEM . . . . .	2
TEST PREPARATIONS . . . . .	3
Test Vehicle . . . . .	3
Fuel System . . . . .	4
Fuel Tank . . . . .	4
Triggering Valve Mount . . . . .	4
"Wedge-Lock" Retainer . . . . .	4
Tank Top Access Covers . . . . .	5
Boost Pump Mounting Diaphragm . . . . .	6
Crossover Tubes . . . . .	6
Fuel Lines . . . . .	9
Fuel Valves . . . . .	14
Structural Attachments . . . . .	17
Engine . . . . .	22
Fuel Flow . . . . .	24
Test Fuel . . . . .	24
Emulsified Fuel Operation . . . . .	24
Auxiliary Fuel System . . . . .	25
Lubricating Oil System (Engine and Transmission) . . . . .	25
Engine . . . . .	26
Transmission . . . . .	28
Hydraulic System . . . . .	29
Electrical System . . . . .	31
Remote Flight Control System . . . . .	35
Helicopter Installation . . . . .	36
Instrumentation . . . . .	38
TEST CONDITIONS . . . . .	41

TABLE OF CONTENTS (CONT'D.)

	<u>Page</u>
TEST OPERATIONS AND CRASH ANALYSIS . . . . .	42
TEST RESULTS . . . . .	47
Fuel System . . . . .	47
Fuel Tank . . . . .	47
Triggering Valve Mount. . . . .	47
Wedge-Lock Retainer . . . . .	47
Boost Pump Mounting Diaphragm . . . . .	47
Crossover Tubes . . . . .	47
Fuel Lines . . . . .	49
Fuel Valves. . . . .	49
Structural Attachments . . . . .	50
Engine . . . . .	51
Lubricating Oil System . . . . .	52
Engine . . . . .	53
Transmission . . . . .	54
Hydraulic System . . . . .	54
Electrical System . . . . .	57
Remote Control System . . . . .	57
Instrumentation . . . . .	58
Follow-on Test . . . . .	58
CONCLUSIONS. . . . .	59
RECOMMENDATIONS . . . . .	60
LITERATURE CITED . . . . .	61
APPENDIXES	
I. Flexible Triggering Valve Mount Tests (Tank Mounted). . . . .	62
II. High-Strength Tank Fitting . . . . .	68
III. Rigid Triggering Valve Mount (Airframe Mounted) . . . . .	73
IV. Self-Sealing Frangible Interconnects . . . . .	79

TABLE OF CONTENTS (CONT'D.)

	<u>Page</u>
V. Frangible Material Tests. . . . .	93
VI. Frangible Fastener Tests . . . . .	112
VII. Method for Determining the Yield Value of Emulsified Fuels by Cone Penetration . . . . .	118
VIII. Frangible Cable Clamps and Electrical Wire Tests . . . . .	123
IX. Vertical Drop Test of a Crash-Resistant Fuel and Lubricating Oil System . . . . .	129
DISTRIBUTION . . . . .	147

LIST OF ILLUSTRATIONS

<u>Figure</u>		<u>Page</u>
1	Test Helicopter (UH-1A) . . . . .	3
2	Crash-Resistant Fuel Tank Installation . . . . .	5
3	Triggering Valve Mount (Tank Mounted) . . . . .	6
4	Wedge-Lock Retention Method . . . . .	7
5	Boost Pump Mounting Diaphragm . . . . .	8
6	Pre-Installation View of Left Fuel Cell, Showing Half of Aft Crossover Assembly . . . . .	9
7	Aft Crossover Tube Attachment to Left Fuel Cell in Battery Compartment . . . . .	10
8	Aft Crossover Tube Attachment to Right Fuel Cell in Cargo Suspension Unit Compartment . . . . .	10
9	UH-1A Fuel System <u>Before</u> Fuel Line Modification. . . . .	11
10	UH-1A Fuel System <u>After</u> Fuel Line Modification . . . . .	12
11	Triggering Valve Mount for Self-Sealing Quick- Disconnect Valves . . . . .	13
12	Valve Installations as Viewed From Engine Side of UH-1A Service Deck . . . . .	13
13	Below-Deck View of Valve Installations . . . . .	14
14	Load Transfer Cable. . . . .	15
15	Quick-Disconnect Valve. . . . .	16
16	Type A Self-Sealing Breakaway Interconnect. . . . .	18
17	Filler Neck Attachment (Original Design). . . . .	19
18	Filler Neck Attachment (Crashworthy Design) . . . . .	19

<u>Figure</u>		<u>Page</u>
19	Boost Pump Installation. . . . .	21
20	Rock Attached Beneath Helicopter To Simulate Rough Terrain Impact on Boost Pump Installation . . . . .	22
21	Frangible Fiber Glass Wall Stabilitzer. . . . .	23
22	Auxiliary Fuel Tank . . . . .	25
23	Oil Reservoir With Crash-Resistant Covering . . . . .	26
24	Oil Cooler Modifications . . . . .	27
25	Transmission Oil Supply Area . . . . .	29
26	Transmission Schematic Illustrating Coiled Tube Experiment . . . . .	30
27	Hydraulic System Showing Flexible Metal Line on Right Side of Installation . . . . .	31
28	Battery Installation . . . . .	33
29	Boost Pump Modification . . . . .	34
30	Insulated Wiring in Battery Compartment. . . . .	35
31	Frangible Wiring Clamp Installation . . . . .	36
32	Remote Control System Installation and Connection to Copilot Flight Controls . . . . .	37
33	Pilot Control Switch Panel on Cyclic Stick . . . . .	37
34	Gyro Installation . . . . .	38
35	Onboard Instrumentation . . . . .	39
36	High-Speed Camera Locations . . . . .	40
37	Tail Boom Broken From Fuselage . . . . .	43

<u>Figure</u>		<u>Page</u>
38	View of Helicopter Underside Showing Damage and Absence of Skids. . . . .	43
39	Main Transmission and Rotor Mast in Wreckage . . . . .	44
40	Postcrash Position of Engine . . . . .	44
41	Position of Main Rotor Blades in Wreckage . . . . .	45
42	Bottom View of Fuselage Break . . . . .	45
43	Deformed Structure and Exposed Fuel Cell . . . . .	48
44	Tank System and Aft Crossover Assembly Reassembled After Test . . . . .	48
45	Service-Deck-Mounted Triggering Valve Mounts Shown After Fuel (Arrow 1) and Oil (Arrow 2) Lines Separated at Impact . . . . .	49
46	Postcrash View of Boost Pump Installation . . . . .	51
47	Engine Fuel Control Filters After Test Flight on Emulsified Fuel . . . . .	52
48	Crushed Oil Reservoir . . . . .	53
49	Postcrash View of the Transmission Area . . . . .	55
50	Coiled Metal Line Experiment . . . . .	55
51	Postcrash View of Hydraulic System . . . . .	56
52	Hydraulic Pump Broken From Transmission Mount . . . . .	56
53	Electrical Wires Separated From the Frangible Clamps . . . . .	57
54	Flexible Triggering Valve Mount. . . . .	63
55	Method for Converting Off-Center Loads to Straight Tension Loads . . . . .	64

<u>Figure</u>	<u>Page</u>
56 Valve and Trigger Mount Oriented for a Pure Tension Load Application . . . . .	64
57 Valve and Trigger Mount Oriented for a 45-Degree Load Application . . . . .	65
58 Valve and Trigger Mount Oriented for a Shear/Bending Load Application . . . . .	65
59 Schematic of Load Application Modes for Tank-Mounted Triggering Valve Mount and Self-Sealing Quick-Disconnect Valve . . . . .	66
60 Conventional Load Transfer Methods . . . . .	69
61 Tank Wall Failure as a Result of Overstressed Bearing Holes . . . . .	69
62 Wedge-Lock Fitting . . . . .	70
63 Wedge-Lock Load Transfer Method . . . . .	71
64 Fiber-Lock Fitting . . . . .	72
65 Modified and Standard Configuration Quick-Disconnect Valve . . . . .	74
66 Rigid Triggering Valve Mount. . . . .	75
67 Rigid-Mount Triggering Technique Used During Straight Tension Load Applications . . . . .	76
68 Rigid-Mount Triggering Technique Used During Lateral Load Displacement . . . . .	76
69 Rigid Triggering Mount Test Setup . . . . .	77
70 Frangible Interconnect, Type A Illustrated . . . . .	79
71 Interconnect Installation in Simulated Aircraft Tanks and Structure . . . . .	82

<u>Figure</u>		<u>Page</u>
72	General Frangible Interconnect Dynamic Test Setup . . .	82
73	Direction of Load Application . . . . .	83
74	Frangible Material Test Specimen . . . . .	94
75	Tension Load . . . . .	95
76	Bending Test . . . . .	95
77	Frangible Ring. . . . .	98
78	Frangible Ring Load Application Diagram. . . . .	99
79	Shear Test . . . . .	102
80	Tension Tests . . . . .	103
81	General Test Setup Showing Truck, Frangible Material, Fitting, Cable, and Snaring Device . . . . .	108
82	Straight Union Fitting - Pure Tension Load Application . . . . .	108
83	Elbow Fitting - Bending Load Application. . . . .	109
84	Elbow Fitting - Shearing Load Application . . . . .	109
85	Straight Union Fitting - Bending Load Application . . . . .	110
86	Test Fixture for Single Fastener Static Tests . . . . .	113
87	Test Fixture for 12-Fastener Grouping Simulating Boost Pump Mounting Plate . . . . .	114
88	Penetrometer . . . . .	119
89	Penetrometer Cone . . . . .	121
90	Yield Value Versus Penetration Graph. . . . .	122
91	Test Load Application for Teflon Cable Clamp . . . . .	124
92	Test Load Application for Nylon Cable Clamp . . . . .	124

<u>Figure</u>	<u>Page</u>
93 Wire Pulling Technique . . . . .	125
94 Right Side of Test Fuselage Section . . . . .	130
95 Left Side of Test Fuselage Section . . . . .	130
96 Posttest View of Section - Left and Rear Sides . . . . .	133
97 Posttest View of Section - Right and Front Sides . . . . .	133
98 Posttest Condition of Bottom of Fuselage Section . . . . .	134
99 Acceleration - Time History Recorded on Top of Left Fuel Cell . . . . .	135
100 Acceleration - Time History Recorded on Top of Right Fuel Cell. . . . .	136
101 Posttest Bottom View of Left Fuel Cell . . . . .	137
102 Damage to Boost Pump and Fuel Cell . . . . .	137
103 Railroad Tie Penetration Into Left Cell . . . . .	138
104 Fuel Quantity Indicator After Test . . . . .	138
105 Posttest View of Frangible Tank Wall Stabilizer at the Tank-to-Engine Fuel Line Airframe Opening . . . . .	140
106 Remains of the Frangible Tank Wall Stabilizer Surrounding the Tank-to-Engine Tank Outlet. . . . .	140
107 Posttest Position of Breakaway Valve in Forward Crossover Attachment to Left Cell . . . . .	141
108 Posttest Position of Breakaway Valve in Forward Crossover Attachment to Right Cell. . . . .	141
109 Forward and Aft Crossover Assemblies After the Test . . . . .	142
110 Aft Crossover Assembly Separation From the Right Cell . . . . .	142

<u>Figure</u>		<u>Page</u>
111	Aft Crossover Assembly Separation From the Left Cell. . . . .	143
112	Breakaway Interconnect Separation - Right Side . . . .	143
113	Breakaway Interconnect Separation - Left Side . . . .	144
114	Posttest Front View of Oil Cooler . . . . .	144
115	Posttest Rear View of Oil Cooler. . . . .	145
116	Oil Cooler After Removal From Test Section . . . . .	145

LIST OF TABLES

<u>Table</u>	<u>Page</u>
I Flexible Triggering Valve Mount Tests . . . . .	67
II Rigid Triggering Valve Mount Tests . . . . .	78
III General Specifications - Self-Sealing Frangible Interconnects. . . . .	80
IV Comparison of Interconnects . . . . .	89
V Cell-to-Cell Interconnect Comparison Ratings. . . . .	90
VI Frangible Material Tests. . . . .	96
VII Frangible Filler Neck Mounting Ring Tests. . . . .	100
VIII Frangible Ring Static Tests . . . . .	104
IX Frangible Baffle Test Results . . . . .	111
X Frangible Fastener Test Results - Configurations A, B, C, and D . . . . .	115
XI Frangible Fastener Test Results - Configuration E . . . . .	116
XII Frangible Fastener Test Results - Configuration F . . . . .	117
XIII Teflon Cable Clamp Tests . . . . .	126
XIV Nylon Cable Clamp Tests. . . . .	126
XV Electrical Wire Tests (Tension) . . . . .	127
XVI Aluminum Alloy Loop-Type Support Clamp Tests. . . . .	127

**BLANK PAGE**

## INTRODUCTION

A U. S. Army-sponsored crash fire research program has been in progress at the AvSER facility of Dynamic Science in Phoenix, Arizona, for six years. During this period many concepts and new methods of crash fire prevention have been conceived and documented. Some have been tested in full-scale aircraft crash tests. The merits of others have been determined by static and dynamic component tests. Still others have been proven by other agencies, military and civilian, in tests and in actual use. Most of these improvements were included as recommendations in Chapter 8 of USAAVLABS Technical Report 67-22, "Crash Survival Design Guide", authored by AvSER and published by the U. S. Army Aviation Materiel Laboratories (USAAVLABS), Fort Eustis, Virginia in July 1967.\* (1)

Many of the recommendations pertaining to fluid containment and fluid modification contained in the "Crash Survival Design Guide" were untried in current state-of-the-art aircraft. A UH-1A helicopter was made available by USAAVLABS as a test vehicle under Contract DAAJ02-67-C-0004. The UH-1, with its turbine engine and improved flight and range characteristics, is representative of the modern helicopters.

The fuel, oil, hydraulic and electrical systems of the helicopter were examined in detail, and decisions were made as to what systems, or portions thereof, could be modified to test and/or prove the validity of specific crash-resistance concepts. Most of the modifications that were performed are discussed in the "Crash Survival Design Guide"(1).

---

\*Revised - December 1967 (AD 670955).

## APPROACH TO THE PROBLEM

The primary objective of this crash-fire test was to evaluate some laboratory methods of improving flammable fluid spillage control in survivable aircraft accidents by crashing a UH-1A helicopter whose functional systems had been modified in accord with the laboratory methods.

The concepts and innovations devised to improve flammable fluid spillage control were evaluated to minimize the possibility of operational failure before they were installed in the UH-1A helicopter. The fuel system was modified by installing new crash-resistant fuel tanks, self-sealing break-away valves, frangible interconnects, and frangible tiedowns at critical points in the system. The lubricating oil system reservoir received a special protective covering, and certain lines were replaced and/or rerouted to safer locations. A check valve was installed in the reservoir-to-engine supply line to prevent leakage if the line failed. A line in the hydraulic system was replaced with a new type of flexible metal line. Some of the electrical wiring was rerouted, and rigid tiedown clamps were replaced with frangible ones to reduce wire failures due to structural deformation. The battery tiedown was modified and strengthened.

A secondary objective of the overall UH-1 modification program was to test the practicality of operating aircraft on an emulsified JP-4 fuel with a minimum of modifications. The natural flow resistance of the emulsion posed many problems, including pumping, line delivery, and fuel control metering. The effects of the emulsion on screens, seals, etc., and the possibility of line stoppages provided possible problem areas. With these problems in mind, methods of operating the helicopter on emulsified fuel were explored.

An auxiliary fuel system was designed to provide liquid JP-4 fuel for engine operation until operation on the emulsified JP-4 was desired. When the auxiliary system was turned off, the emulsion stored in the helicopter fuel tanks was fed to the engine.

## TEST PREPARATIONS

### TEST VEHICLE

The test vehicle was a UH-1A helicopter, Figure 1. It was a utility-type aircraft powered by the T53-L-1 gas turbine power plant. Power to the single main rotor and the tail rotor was extracted from the compressor inlet end of the engine by means of a coaxial through-shaft arrangement and an integral reduction gear assembly.

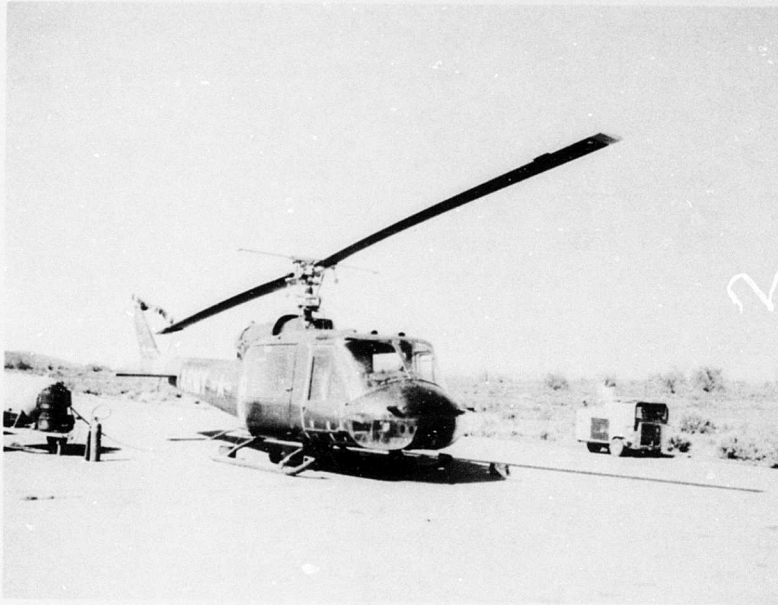

Figure 1. Test Helicopter (UH-1A).

The construction of the forward section of the helicopter consisted primarily of two longitudinal beams with transverse bulkheads and metal covering. The beams provided the supporting structure for the cabin sections, landing gear, fuel tanks, transmission, engine, and tail boom and are the attaching points for the external cargo suspension unit. The tail boom is a semimonocoque structure with metal covering and is attached to the forward section with bolts to allow easy removal or replacement. The rear of the tail boom supports the tail rotor, vertical fin, and synchronized elevator. The landing gear is of the skid type, attached to the fuselage at four points.

## FUEL SYSTEM

### Fuel Tank

Both of the standard UH-1A rubberized-cloth fuel cells were removed and replaced by special crash-resistant ones made of 4-ply nylon cloth material. The tanks were designed and constructed in accordance with the design criteria set forth in USAAVLABS Technical Report 66-24, "Aircraft Fuel Tank Design Criteria"<sup>(2)</sup>, and in USAAVLABS Technical Report 67-6, "Improved Crash-Resistant Fuel Cell Material"<sup>(3)</sup>. The puncture and tear resistance of the 4-ply nylon cloth construction exceeded the minimum values as specified in USAAVLABS Technical Report 66-24.

During tank manufacture, two special valve mounts were molded into the tank wall. A discussion of each follows.

### Triggering Valve Mount

Five fuel lines exited the fuel tank, three from the left cell and two from the right (Figure 2). To prevent fuel spillage if the forward crossover tube or the tank-to-engine fuel line was pulled from the tank, a self-sealing breakaway valve was installed at each line-to-tank connection. These valves were placed in triggering mounts which were molded in the tank. The mounts, made of a material similar to the actual tank, are shown in Figure 3. Because the mounts were countersunk into the tank, they could allow the valve to separate without interference from collapsing or shifting aircraft structure surrounding the fuel line exit area. More detailed information concerning specific tests performed during the design of these triggering mounts is given in Appendix I.

### Wedge-Lock Retainer

The triggering valve mount was used in three of the fuel line exits. The remaining two exits were located at the aft crossover tube attachment points. To prevent fuel spillage in this area if the aft crossover tube was pulled from the tank, a self-sealing frangible interconnect was attached between the tank and the crossover tube. The interconnect was secured to the tank by means of a wedge-lock retention concept, rather than by the standard bolt technique. The wedge-lock retention method, Figure 4, allowed the interconnect to grip the tank material around a 360-degree periphery. Consequently, pulling the interconnect body out of the tank wall would require the extrusion of the entire hole periphery out of the interconnect gripping area. More detailed information on

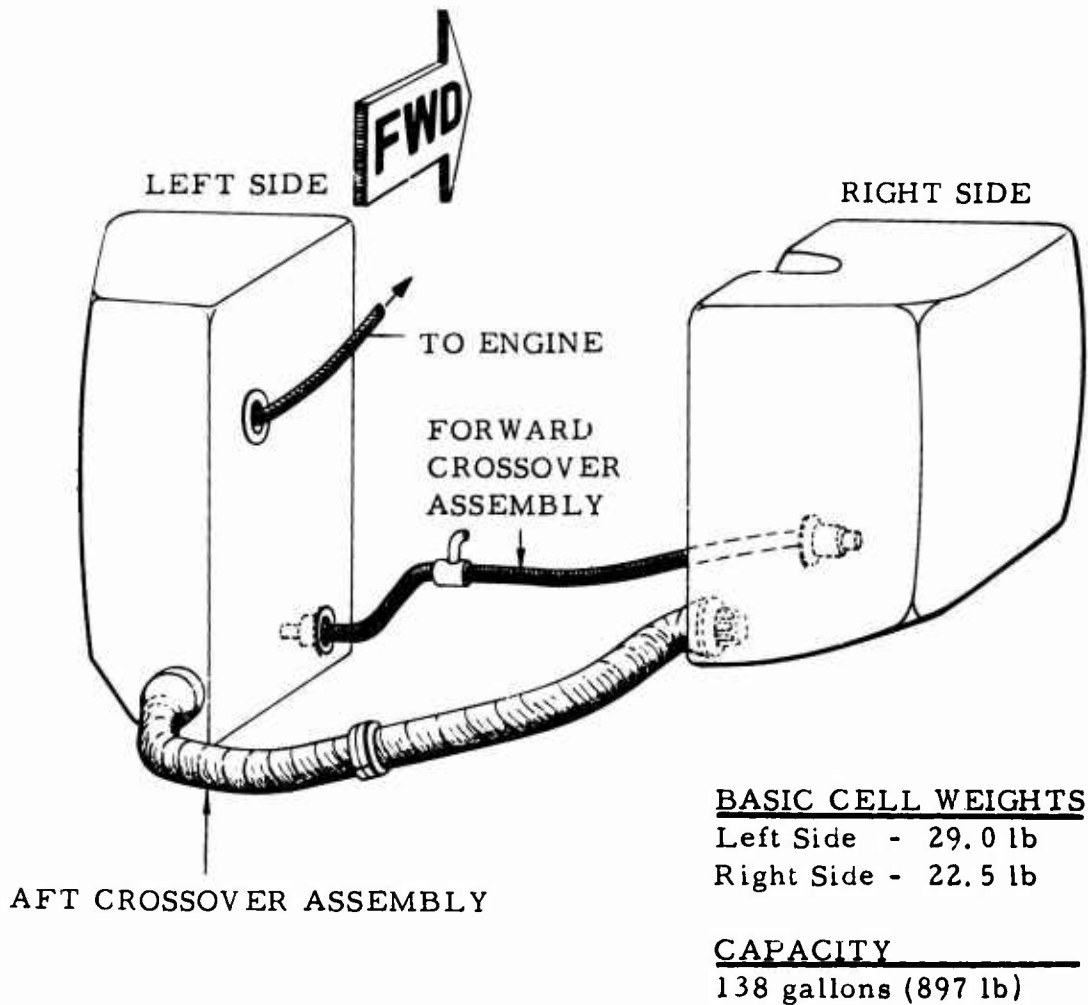

Figure 2. Crash-Resistant Fuel Tank Installation.

wedge-lock construction and tests that were performed during the course of its design is given in Appendix II.

#### Tank Top Access Covers

Each fuel cell was normally closed at the top with a large aluminum access cover. Since these covers could be easily punctured or deformed in a crash by the airframe or power train systems, such as the transmission or engine, they were removed and replaced with covers made of fuel tank material.

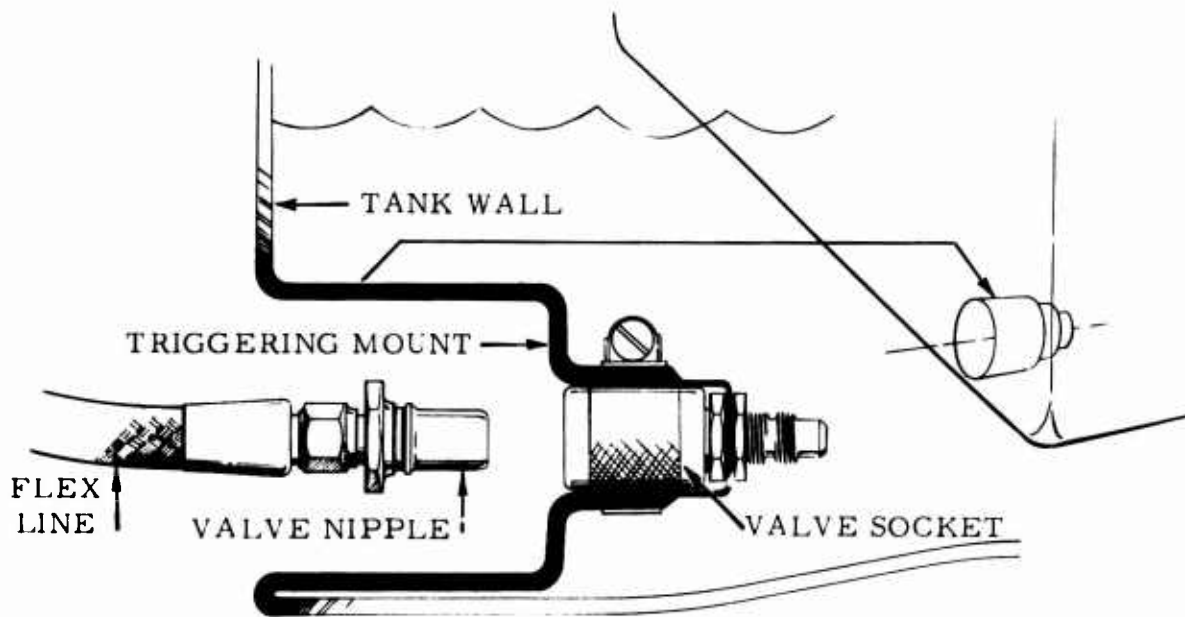

Figure 3. Triggering Valve Mount (Tank Mounted).

#### Boost Pump Mounting Diaphragm

The boost pump was normally mounted in an aluminum diaphragm, which in turn was installed in the fuel cell bottom. Adjacent to the pump, also in the diaphragm, a depressed sump area was located for draining the cell; see Figure 5. Protruding from the sump were two drain valves, one for spot-checking the fuel and the other for draining the system. These drains were especially susceptible to being scraped off during a sliding crash. Also, the aluminum diaphragm was extremely vulnerable to puncture and tear failures. The diaphragm was removed, redesigned slightly, and replaced with one made of flexible nylon material. The new design placed the drain valves in a safer location, as shown in Figure 5. The sump area was constructed of extra plies of nylon cloth to provide additional resistance to abrasion.

#### Crossover Tubes

The standard aft and forward crossover tubes, shown in Figure 2, were replaced. The replacement for the large aft crossover tube was made of material similar to the new tank and was fabricated in two pieces that were joined in the middle exactly as the original design. The tank and the left half of the crossover tube prior to installation are shown in Figure 6.

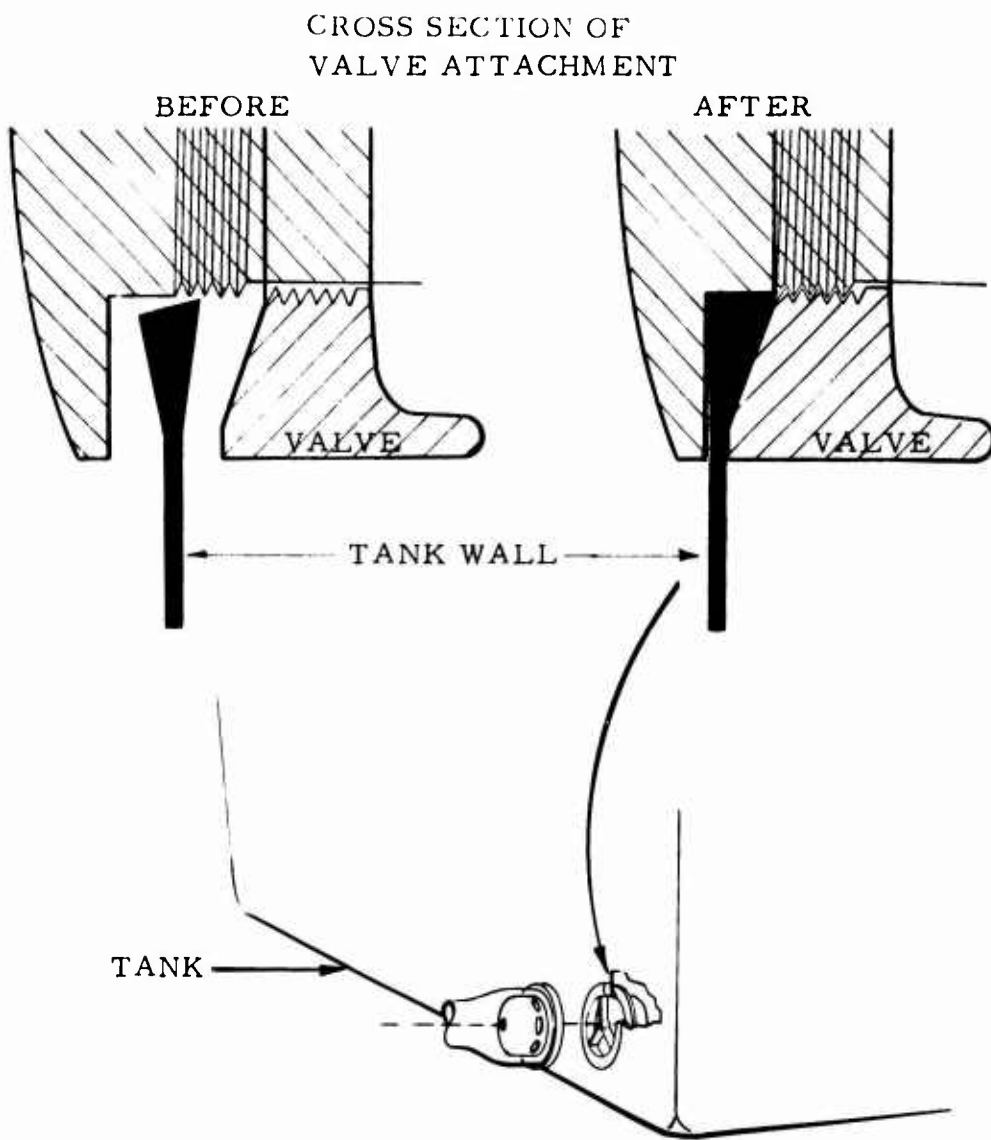

Figure 4. Wedge-Lock Retention Method.

Special-made self-sealing frangible interconnects were installed in the aft crossover cell-entry openings. The aft crossover tube was chemically bonded and clamped to the retention nut that was attached to each interconnect. The aft crossover tube attachments to the left and right fuel cells are shown, respectively, in Figures 7 and 8.

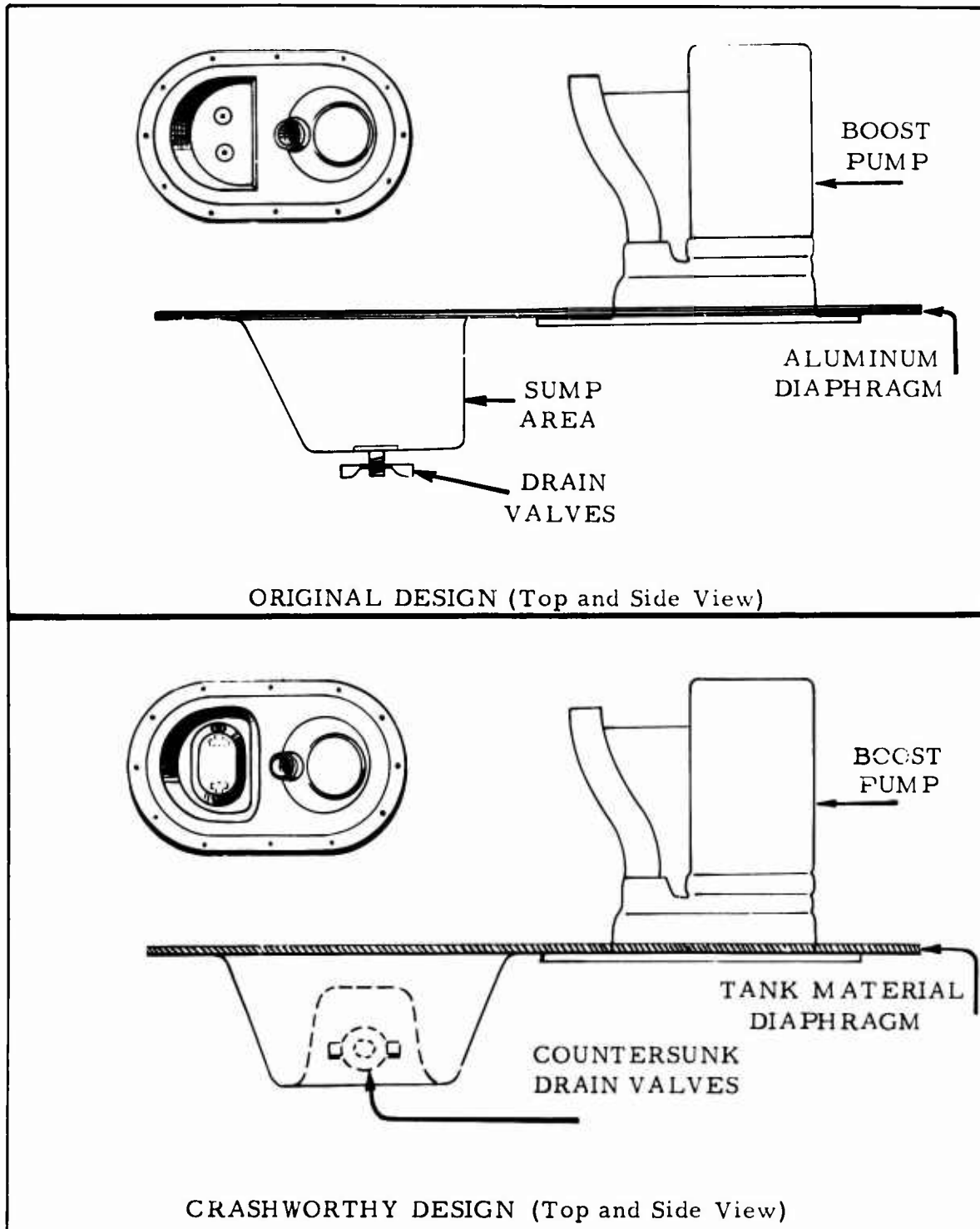

Figure 5. Boost Pump Mounting Diaphragm.

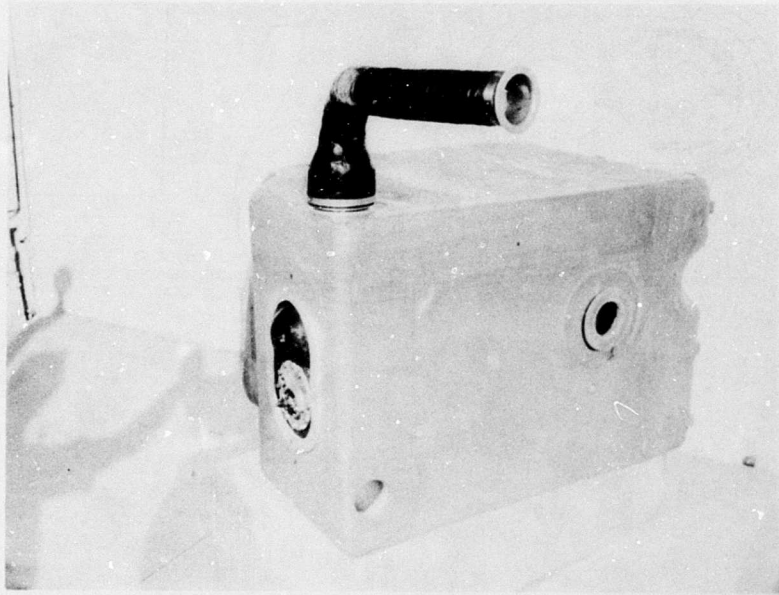

Figure 6. Pre-Installation View of Left Fuel Cell, Showing Half of Aft Crossover Assembly.

The forward rigid aluminum crossover tube was replaced by 3/4-inch flexible hose. The hose was attached to the tanks with self-sealing breakaway valves.

#### Fuel Lines

All lines in the fuel system were evaluated to determine those which were in the more hazardous and critical areas. The main fuel line, the fuel control vent line, and the line for the fuel pressure/heater fuel supply were replaced with flexible hose (Figures 9 and 10) to reduce the probability of line failure.

The bulkhead-type quick-disconnect fittings were removed at the service deck where the fuel and oil lines passed through the deck. They were replaced with self-sealing quick-disconnect valves installed in triggering valve mounts, which made them function as breakaway valves. These mounts, made of stainless steel, were designed to mount flush with the deck and to provide a positive separation point for the valve body. The installations are shown in Figures 11, 12, and 13. Detailed information concerning construction and tests conducted during the design of the service-deck-mounted triggering valve mounts is given in Appendix III.

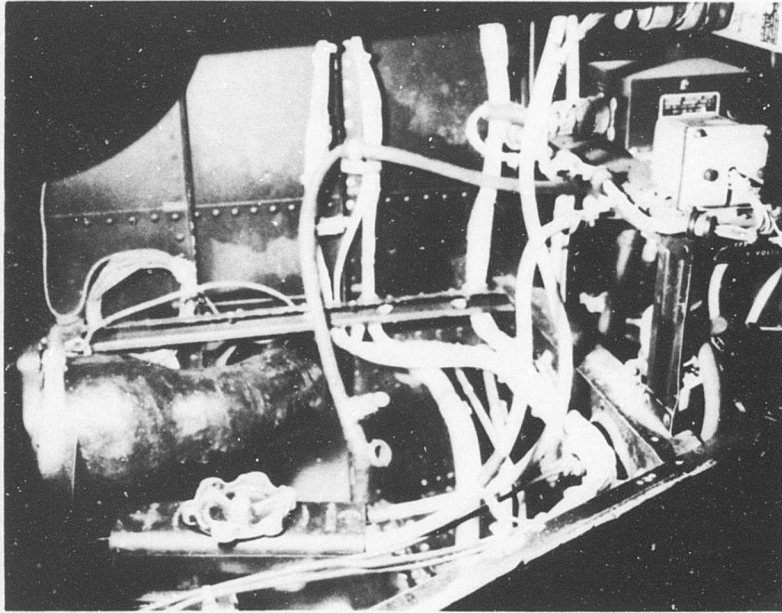

Figure 7. Aft Crossover Tube Attachment to Left Fuel Cell in Battery Compartment.

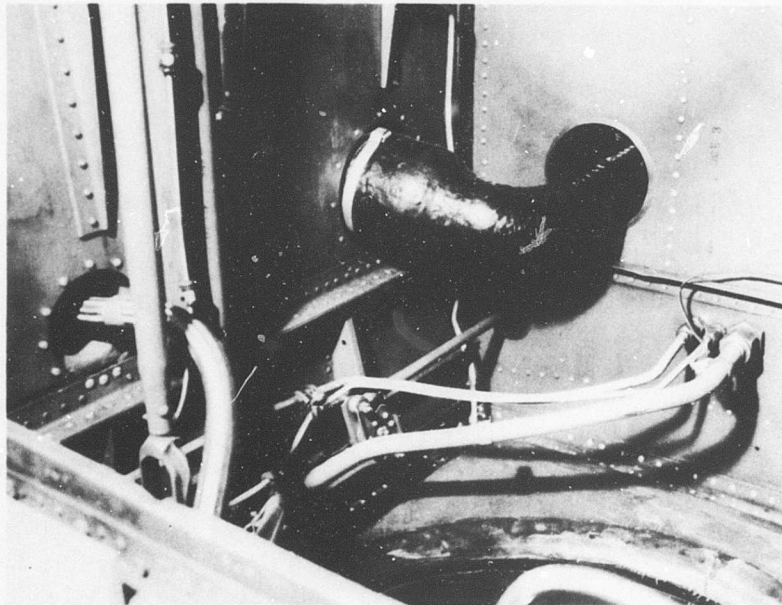

Figure 8. Aft Crossover Tube Attachment to Right Fuel Cell in Cargo Suspension Unit Compartment.

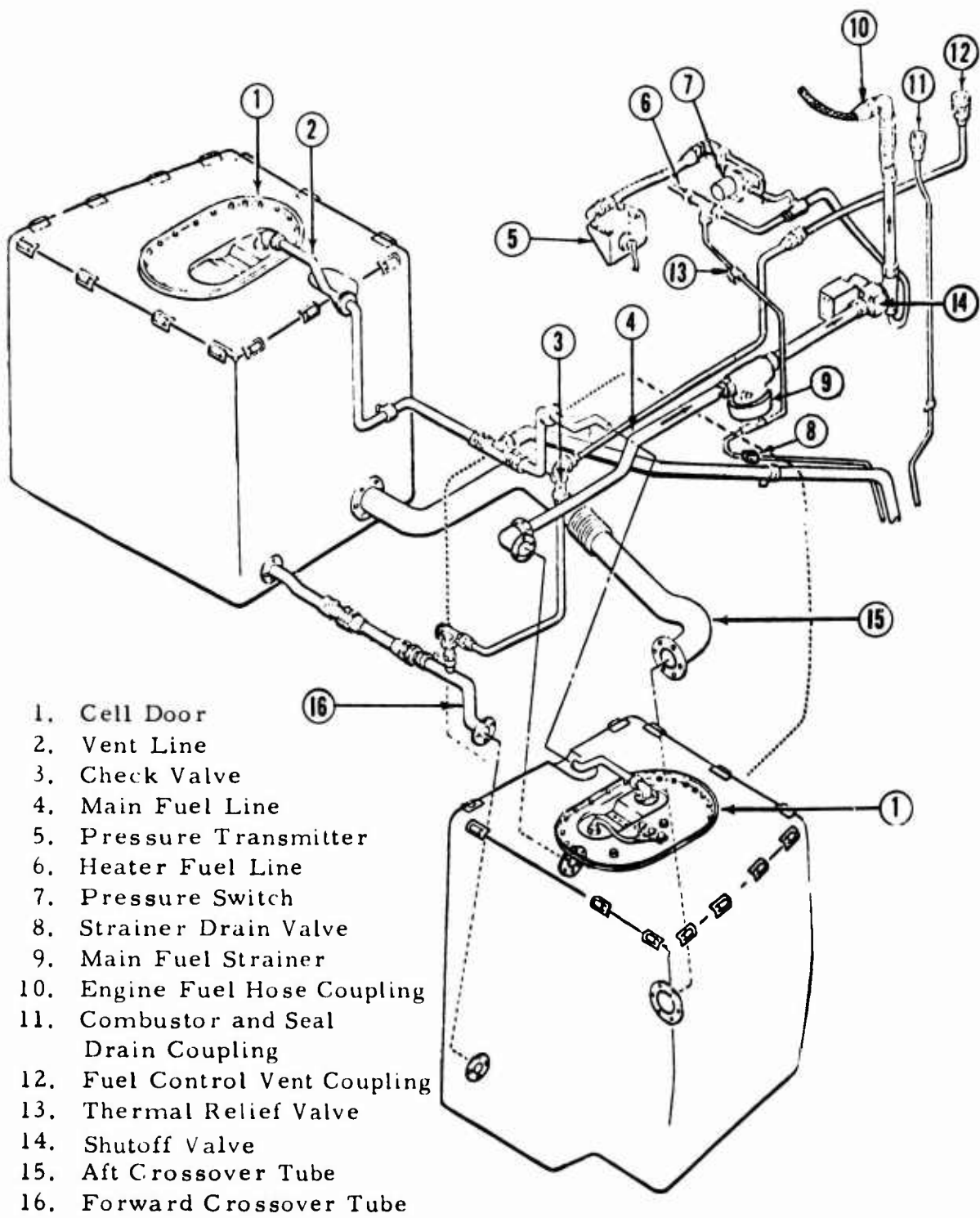
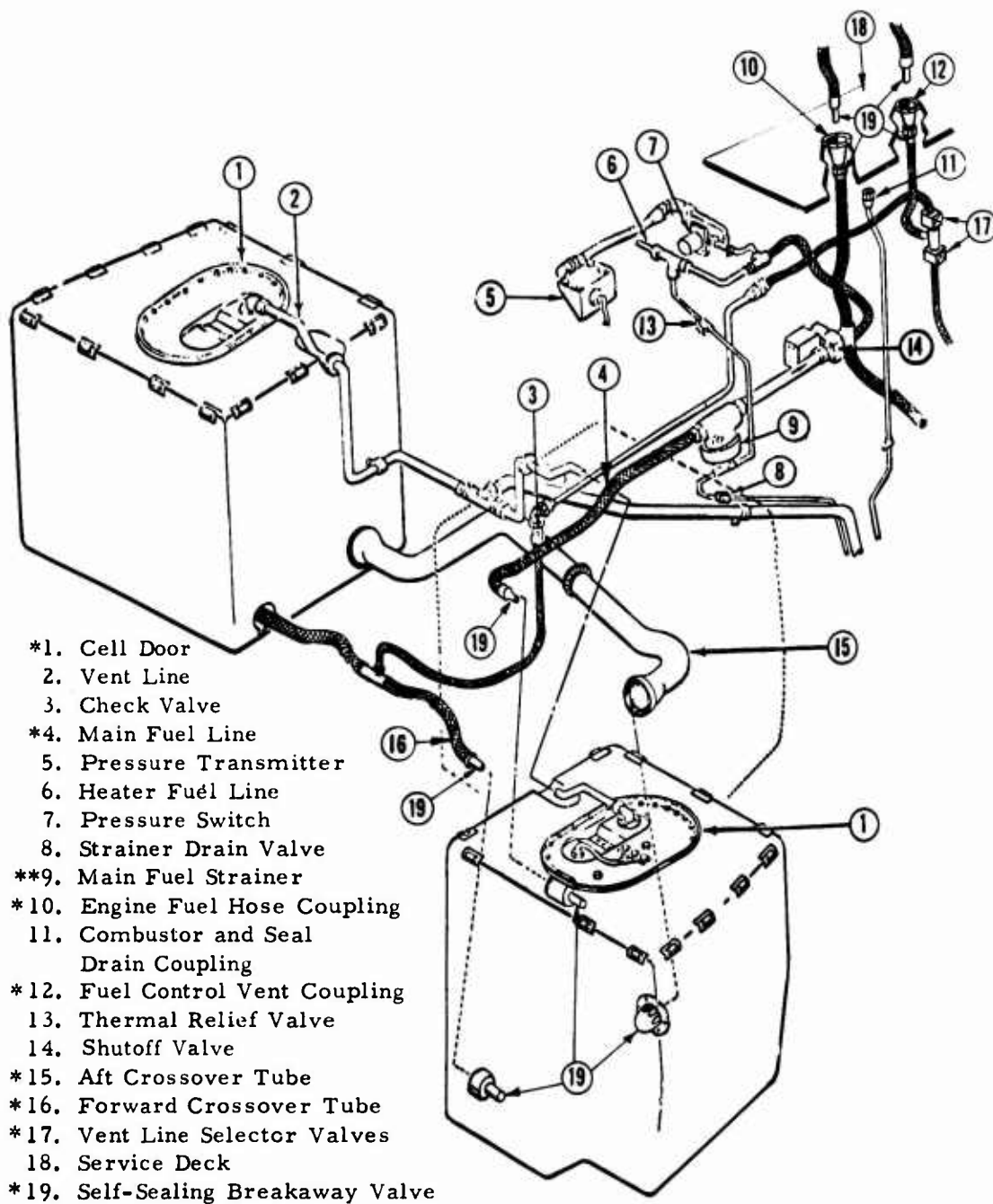

Figure 9. UH-1A Fuel System Before Fuel Line Modification.



- \*1. Cell Door
- 2. Vent Line
- 3. Check Valve
- \*4. Main Fuel Line
- 5. Pressure Transmitter
- 6. Heater Fuel Line
- 7. Pressure Switch
- 8. Strainer Drain Valve
- \*\*9. Main Fuel Strainer
- \*10. Engine Fuel Hose Coupling
- 11. Combustor and Seal Drain Coupling
- \*12. Fuel Control Vent Coupling
- 13. Thermal Relief Valve
- 14. Shutoff Valve
- \*15. Aft Crossover Tube
- \*16. Forward Crossover Tube
- \*17. Vent Line Selector Valves
- 18. Service Deck
- \*19. Self-Sealing Breakaway Valve

\* Denotes change from original UH-1

\*\* Strainer element removed for emulsified fuel operation

Figure 10. UH-1A Fuel System After Fuel Line Modification.

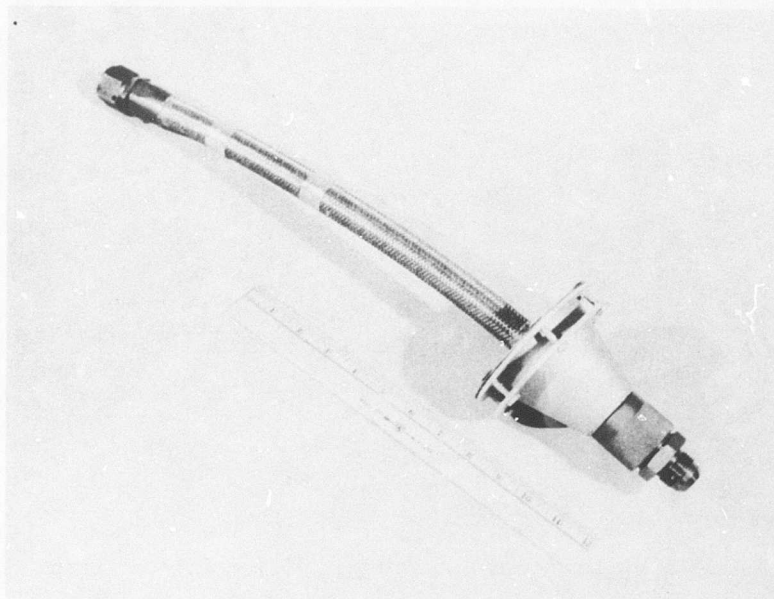

Figure 11. Triggering Valve Mount for Self-Sealing Quick-Disconnect Valves.

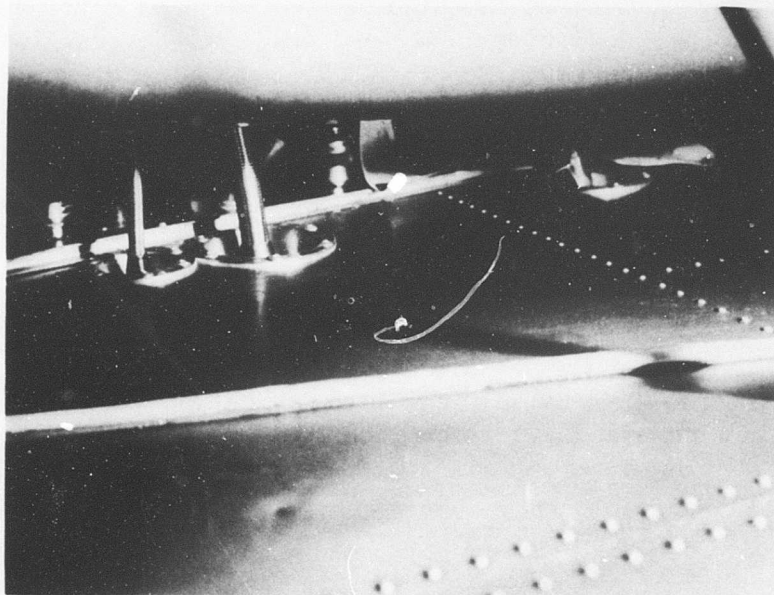

Figure 12. Valve Installations as Viewed From Engine Side of UH-1A Service Deck.

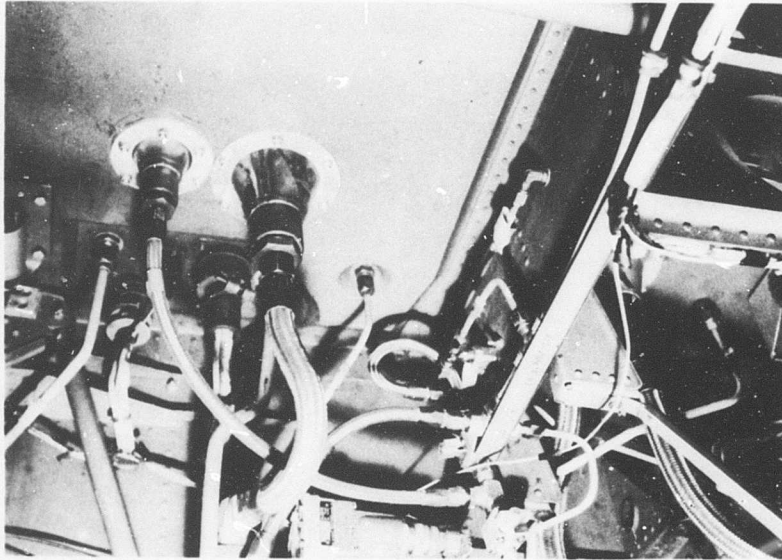

Figure 13. Below-Deck View of Valve Installations.

The fuel control vent line, being 1/4 inch in diameter and containing several elbow fittings near the fuel control, posed an additional problem. This line, with all the relatively weak fittings, was marginally strong enough to carry the load which would be applied between the engine and the self-sealing quick disconnect located in the service deck when the engine was displaced during the crash. Thus, load to the quick disconnect had to be transmitted by some other means. A load transfer cable was installed between the engine and a union placed in the vent line, just above the quick disconnect (Figure 14). The cable would then transmit necessary loading from the engine to the quick disconnect without applying the load directly to the line itself.

### Fuel Valves

To prevent fluid from spilling through open fuel lines at points where the lines connected to the tank, or at points where the lines passed through bulkhead connectors at the service deck, two types of self-sealing breakaway couplings were used: a cell-to-line-type valve and a cell-to-cell-type interconnect.

### Cell-to-Line Valves

Cell-to-line-type valves were installed at each end of the forward crossover tube, at the engine fuel supply line as it exits the tank,

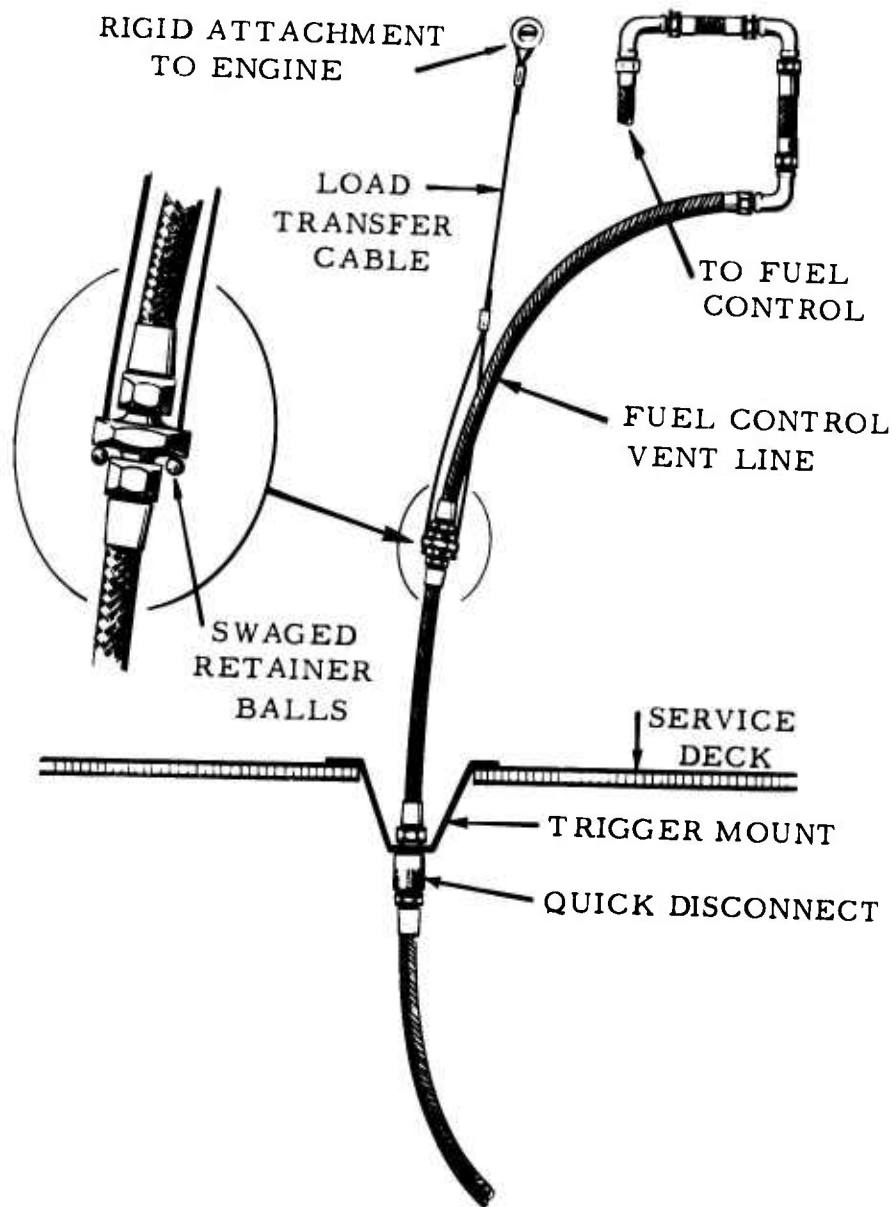

Figure 14. Load Transfer Cable.

and at the service deck just below the engine. As discussed earlier, the tank-mounted valves were installed in triggering valve mounts molded into the tank. The service-deck-mounted valves were installed in steel triggering valve mounts.

The valves used were quick disconnects. The orifice sizes were compatible with existing plumbing. The quick-disconnect valves that were used in the fuel tanks are shown in Figure 15.

The three quick-disconnect valves used in the fuel lines at the service deck were modified slightly to increase the load required to cause valve separation. However, the basic operational characteristics were unchanged. A discussion of the modification to the valves is presented in Appendix III.

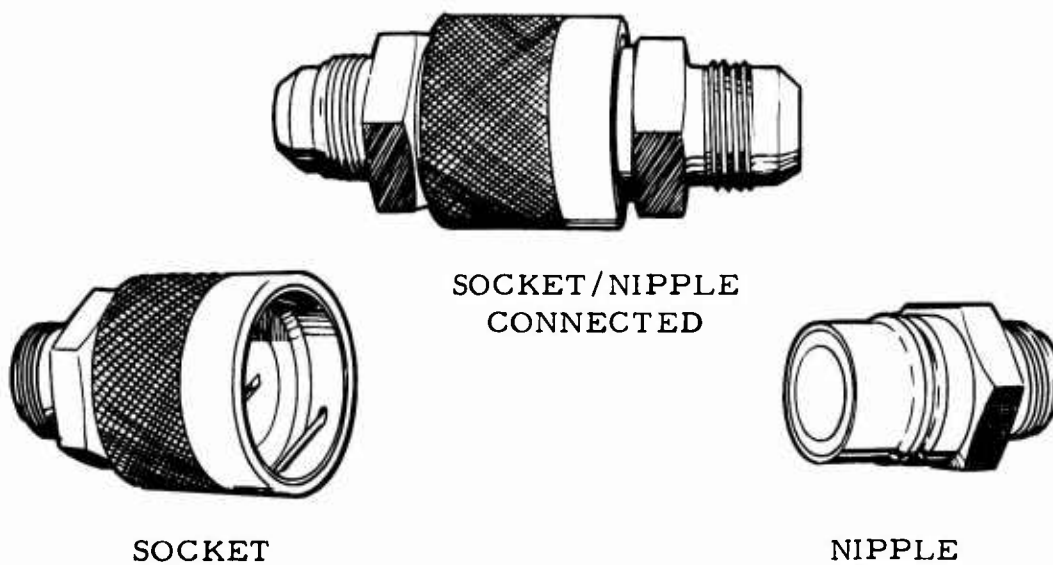

Figure 15. Quick-Disconnect Valve.

### Cell-to-Cell Interconnect

Cell-to-cell, self-sealing breakaway-type interconnects were installed at each end of the aft crossover tube. These interconnects (Figure 16) coupled the fuel tank to the crossover tube. The self-sealing breakaway-type interconnects used were the result of an interconnect test program in which five companies were asked to design and build samples that would comply with a set of Dynamic Science-furnished specifications. The interconnects were then subjected to a series of dynamic tests covering a variety of loads typical of the crash environment. Each interconnect was also evaluated for other desirable values. The Type A interconnect scored best overall; consequently, it was chosen for use in the UH-1A.

A detailed discussion of the interconnect test program is presented in Appendix IV.

### Structural Attachments

To lessen the possibility of tank rupture caused by displacement between the fuel cell and the helicopter structure, three special installations were made. Frangible couplings were installed between the fuel tank filler cap assembly and the airframe, between the boost pump installation area and the airframe, and between the main fuel line tank outlet area and the airframe. Should displacement occur, the frangible couplings were designed to break, thereby allowing the tank and its components to move relative to the fuselage without spilling fuel.

#### Tank Filler Cap Assembly

The new crash-resistant cells were manufactured to take advantage of the existing fuel filler opening in the helicopter skin. The same filler cap and the accompanying hardware into which the cap is normally secured were used for the modification. A more beneficial attachment method was used. The original method, Figure 17, sandwiched the helicopter structure between the cap retention ring and the fuel cell. It also used a total of six bolts. The new method, Figure 18, attached the cap retention ring directly to the tank and attached a frangible ring to the retention ring. The same six bolts served both these functions. The frangible ring was then, in turn, attached to the helicopter structure. This required six additional bolts.

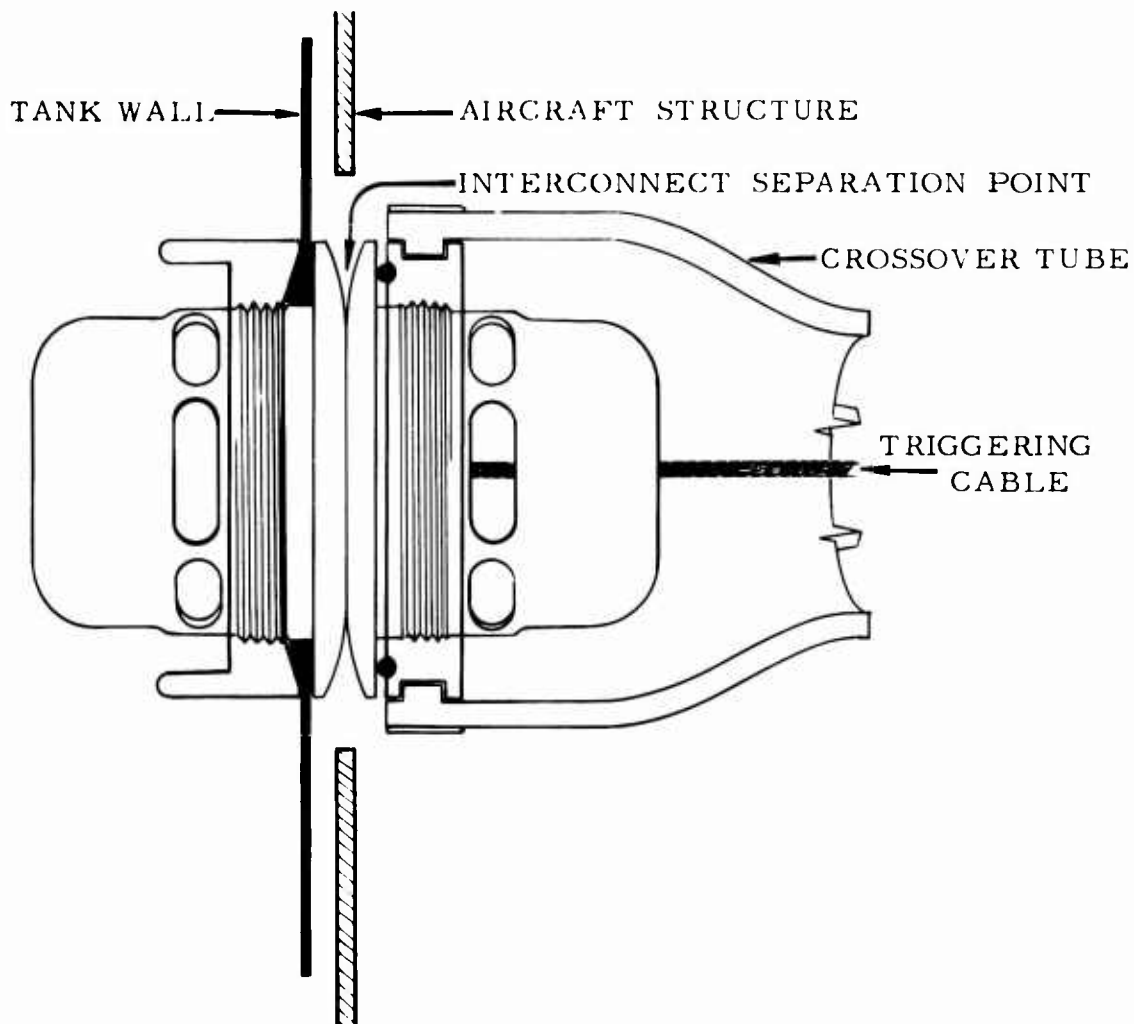

Figure 16. Type A Self-Sealing Breakaway Interconnect.

The modification allowed the filler cap to remain with the tank, preventing spillage; whereas the earlier design kept the cap with the fuselage, thereby insuring spillage.

Detailed information concerning the design tests conducted with the frangible ring is given in Appendix V.

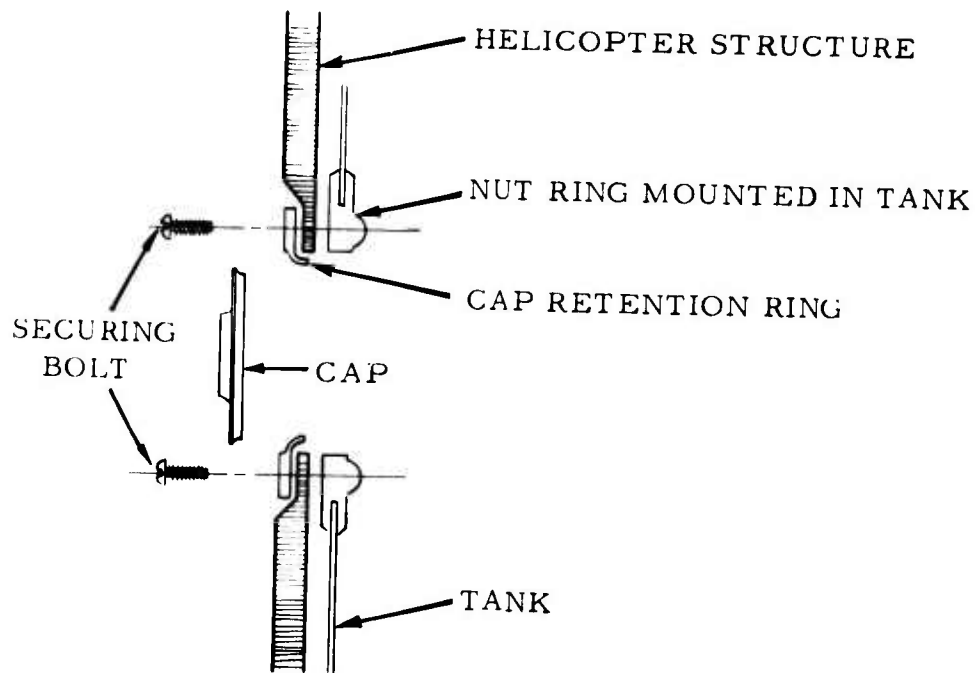

Figure 17. Filler Neck Attachment (Original Design).

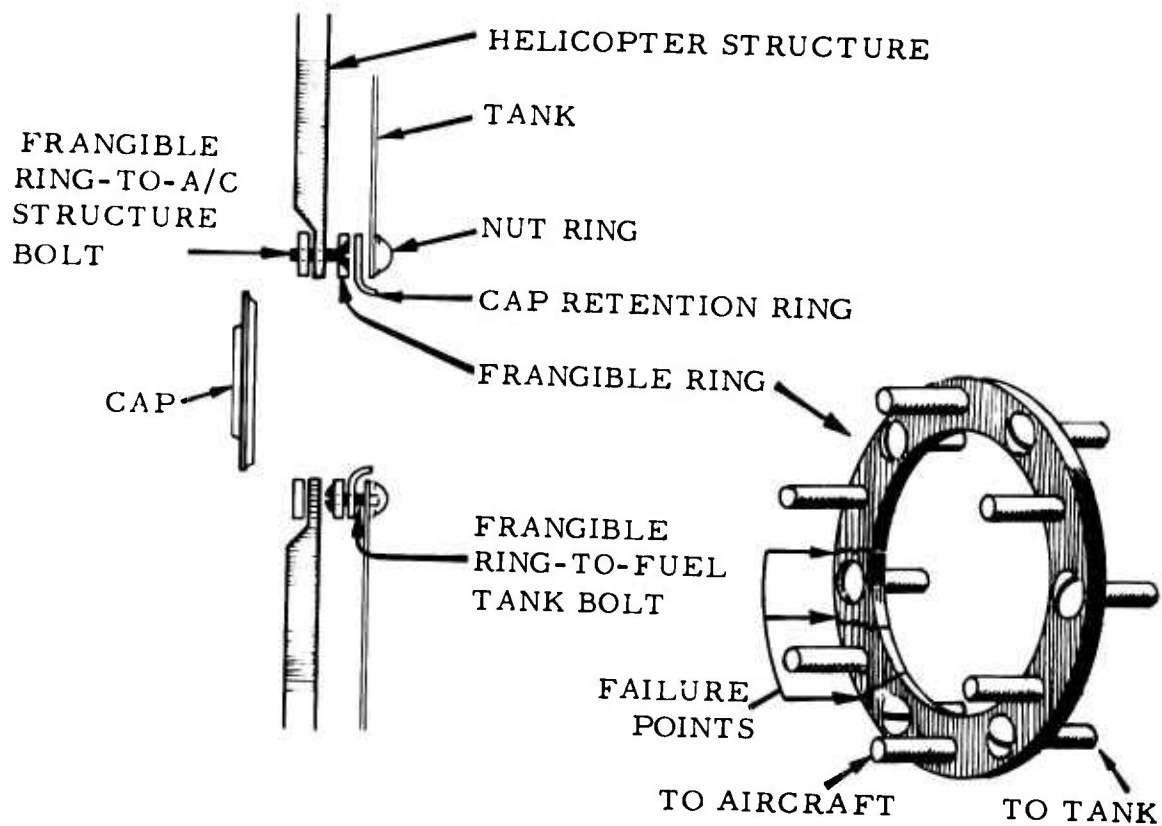

Figure 18. Filler Neck Attachment (Crashworthy Design).

### Boost Pump Installation

The UH-1A single boost pump was reinstalled in the left-hand crash-resistant fuel cell in the same general manner that it was previously. However, there were two exceptions: the wires connecting the pump into the electrical system were rerouted, and a frangible connection was employed in attaching the pump assembly to the helicopter structure at the bottom of the cell cavity. The rewiring of the pump installation is discussed in the section on the electrical system. The frangible boost pump connection is discussed below.

The boost pump is normally bolted to a mounting diaphragm, which, in turn, is bolted to the tank. The pump and mounting diaphragm assembly are secured to the tank and to the helicopter airframe with the same bolts. When displacement occurs between the tank and the helicopter, the mounting diaphragm usually is torn from the tank. This hazardous situation was reduced considerably by installing the diaphragm in the tank with one set of bolts and by attaching the diaphragm to the helicopter with frangible screws. Figure 19 illustrates how this was accomplished.

The screws used to attach the pump area to the airframe were made of aluminum and were designed to break away before any load could be applied through them that would endanger the tank. Detailed information concerning tests conducted to determine the load-carrying capability of the aluminum screws is given in Appendix VI.

In an effort to demonstrate the practicality of the concept, a simulated rough terrain impact was chosen for the crash test. A large rock was attached to the aircraft directly beneath the pump area; see Figure 20.

### Tank Wall Stabilizer

The standard UH-1A fuel tank was bolted directly to the helicopter airframe in the area of the tank-to-engine fuel line exit. This was done for two reasons: to allow the airframe structure to carry the weight of the line and fittings rather than the tank wall, and to stabilize the tank wall in the lateral direction to prevent the fuel line from continually moving in and out through the opening in the airframe.

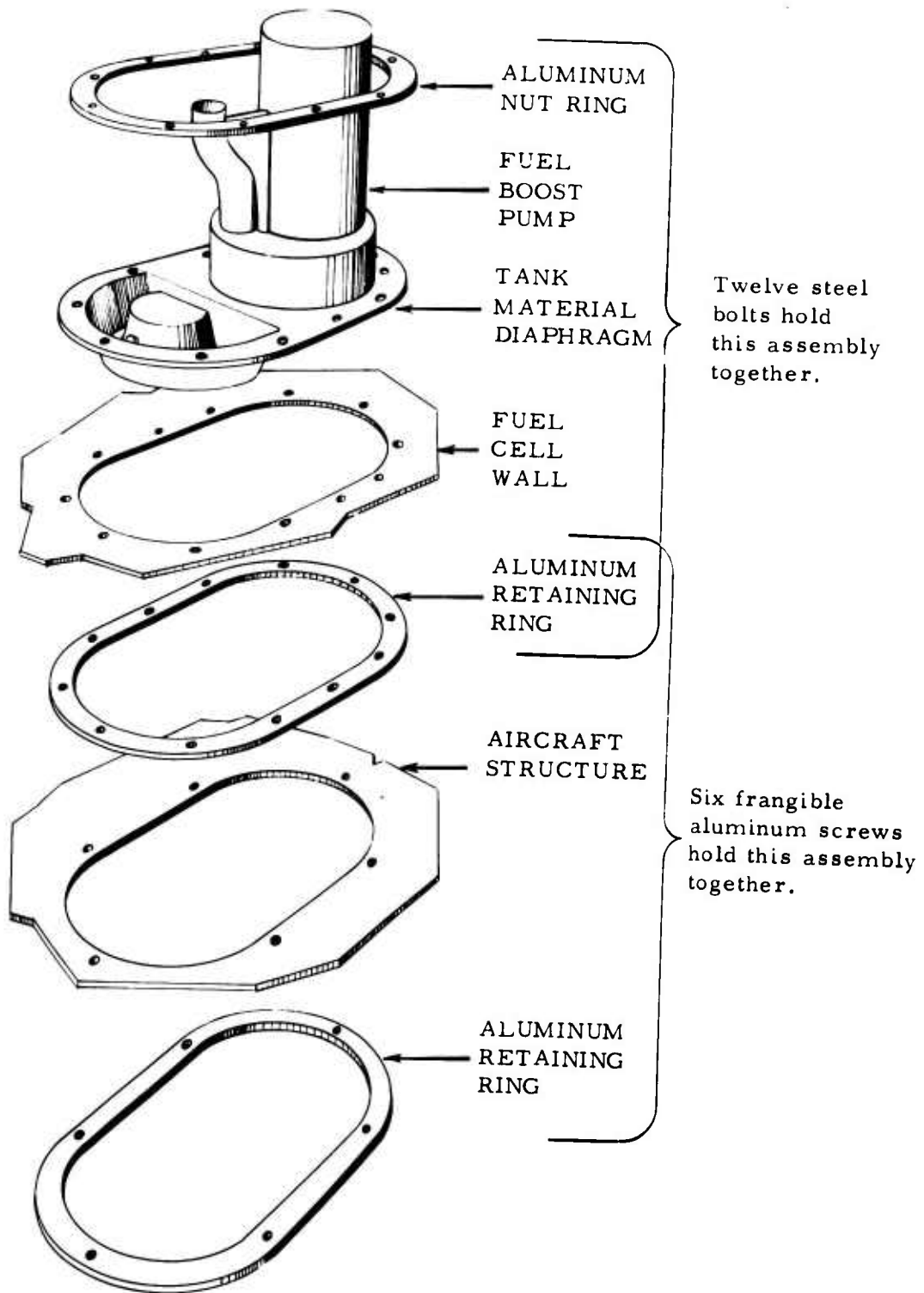

Figure 19. Boost Pump Installation.

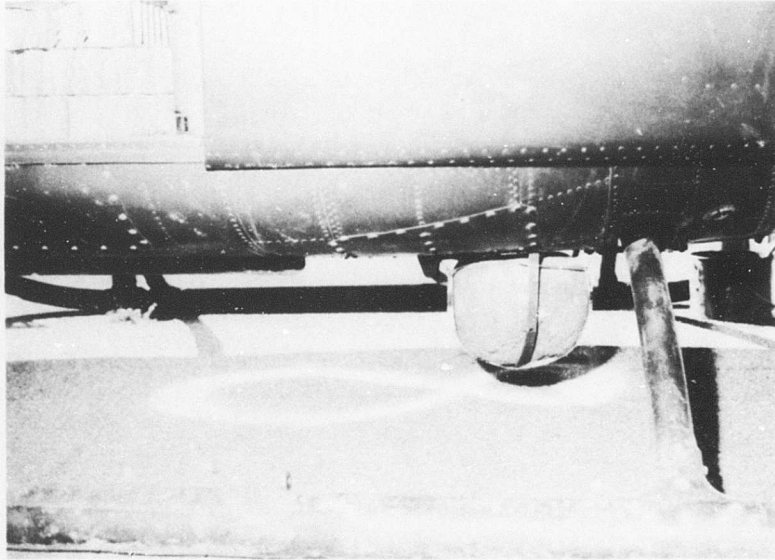

Figure 20. Rock Attached Beneath Helicopter To Simulate Rough Terrain Impact on Boost Pump Installation.

Since all rigid attachments between the fuel tank and the airframe were potential tank failure points, this installation required modification. Frangible tank wall stabilizers were made of fiber glass and inserted into the tank triggering valve mounts (Figure 21). The stabilizers were bonded into the valve mount and bolted to the airframe through the original stabilizer holes. No modifications to the helicopter were required. The fiber glass stabilizers were capable of carrying full flight loads, yet failed at loads approximately one-sixth that required to fail the tank.

### ENGINE

The T53-L-1 gas turbine power plant was located aft of the cabin and was mounted on a service deck to provide maximum accessibility for servicing and maintenance. The engine was a free-turbine-type power plant and consisted of an axial-centrifugal compressor, an external annular vaporizing combustor, a gas-producer turbine, and a free-power turbine. The compressor consisted of five axial stages and one centrifugal stage. The turbine consisted of two axial-flow stages. The first-stage turbine drives the compressor, and the second-stage free-power turbine drives the shaft.

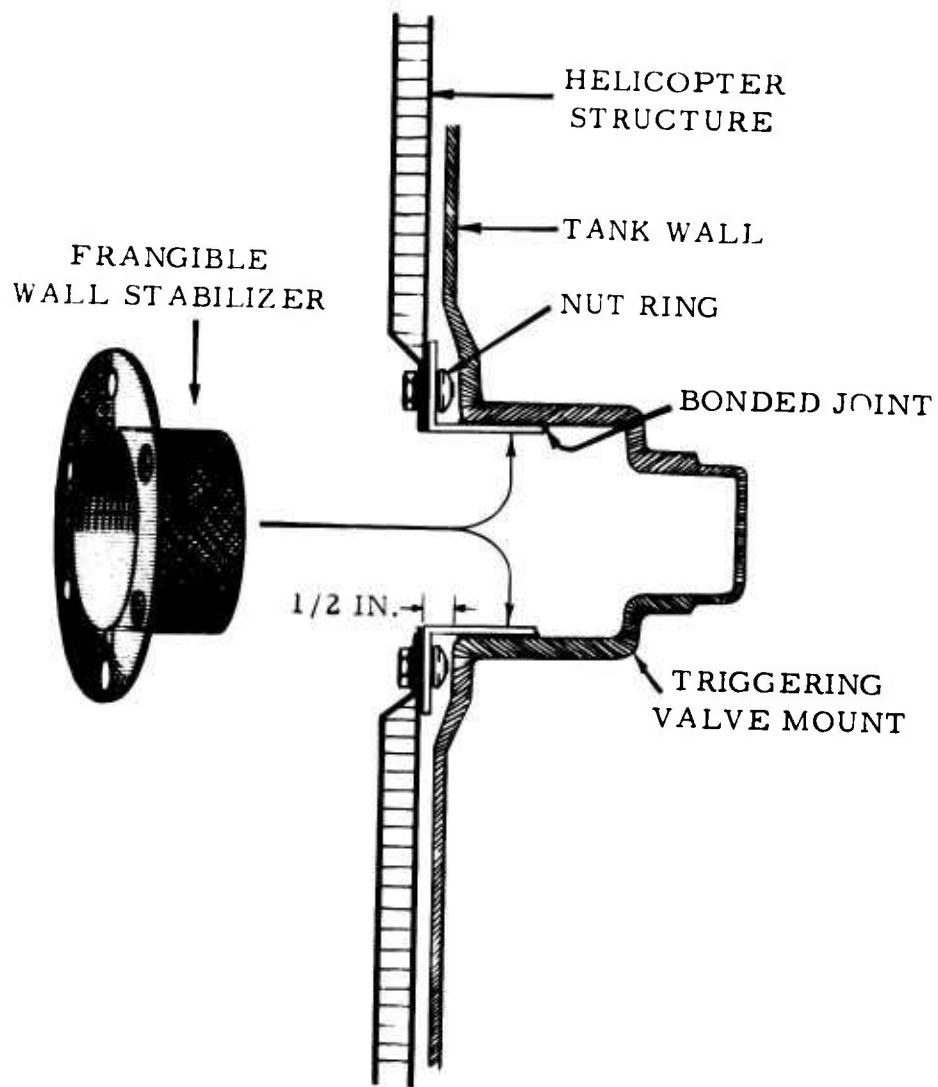

Figure 21. Frangible Fiber Glass Wall Stabilizer.

The complete engine unit and main power transfer system were inclosed by an easily opened or quickly removable lightweight cowling.

### Fuel Flow

Fuel (JP-4) from the helicopter's tank system was delivered to the fuel control unit, filtered, and then boosted in pressure by the dual-element high-pressure fuel pump. It entered and passed through the fuel and power control unit to two discharge ports: main and starting. From the control, fuel flowed directly to the main manifold for distribution to the combustion chamber.

### Test Fuel

The fuel chosen for this test was an emulsified jet fuel. Penetrometer tests on this emulsion showed a consistent yield value of 27.2 millimeters in 5 seconds (1880 dynes/cm<sup>2</sup>) using a 30-gram cone on a Precision Scientific universal penetrometer. Appendix VII presents a detailed explanation of the test procedures used to obtain these values.

### Emulsified Fuel Operation

The procedure for operating the engine on emulsified fuel was as follows:

1. Make normal start on liquid JP-4.
2. Bring systems and temperatures to normal for takeoff conditions.
3. Switch fuel supply to emulsion.
4. Monitor instruments for satisfactory performance of mission.
5. Switch fuel supply back to liquid JP-4 diluted 10 percent with isopropyl alcohol.
6. Operate engine until JP-4/alcohol mixture has purged all emulsion from engine fuel system.
7. Make normal shutdown.

(For the remotely controlled test flight and crash, only the first four items in the procedure were necessary.)

### Auxiliary Fuel System

The helicopter fuel system was filled with emulsion for the crash test; however, a source of liquid JP-4 had to be provided for starting and shutting down the engine. A 5-gallon auxiliary tank was fabricated from crash-resistant material (see Figure 22) to mount either in the aircraft or on the ground. The boost pump installed in the auxiliary tank could be operated on aircraft electrical power, battery power, or generator power when used externally. The supply line from the tank connected into the main system between the engine and the main fuel system shutoff valve.

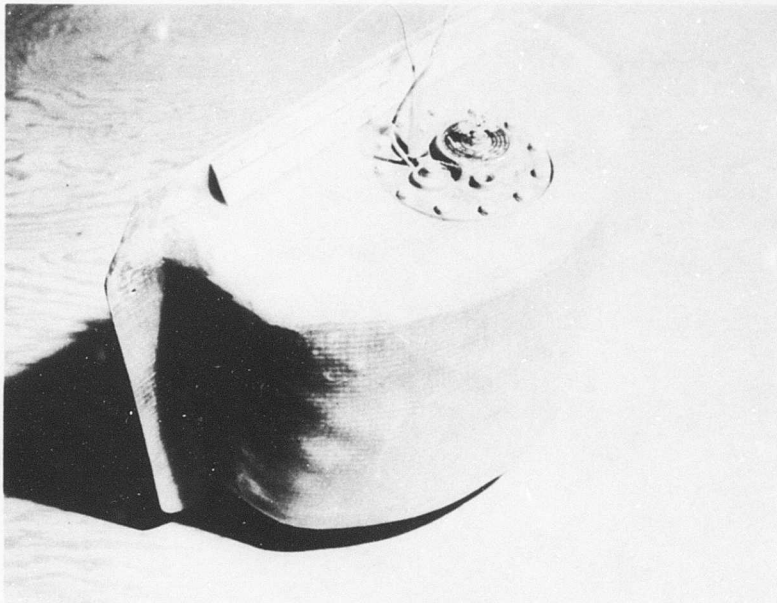

Figure 22. Auxiliary Fuel Tank.

### LUBRICATING OIL SYSTEM (ENGINE AND TRANSMISSION)

The tendency of the engine and transmission systems to fail, releasing a pressurized, hot, highly ignitable mist, has been documented in many accident reports and crash test motion pictures. To minimize this potential fire hazard, several preventive modifications were made during preparations for the test.

## Engine

### Reservoir

The oil reservoir was removed and sheathed in a tight, form-fitting, 1/2-inch-thick felt covering; see Figure 23. The purpose of the felt was twofold: (1) it would readily change its contour to cover any shape that the metal reservoir might assume during a crash, and (2) it would soak up any oil that might spill into the felt from a failure in the metal reservoir. The felt was coated on its external surface with a polyurethane resin to make the sheath liquid-tight, to enhance the fire-resistant properties of the felt, and to prevent the external surface from functioning as a wick if the felt soaked up any spilled oil.

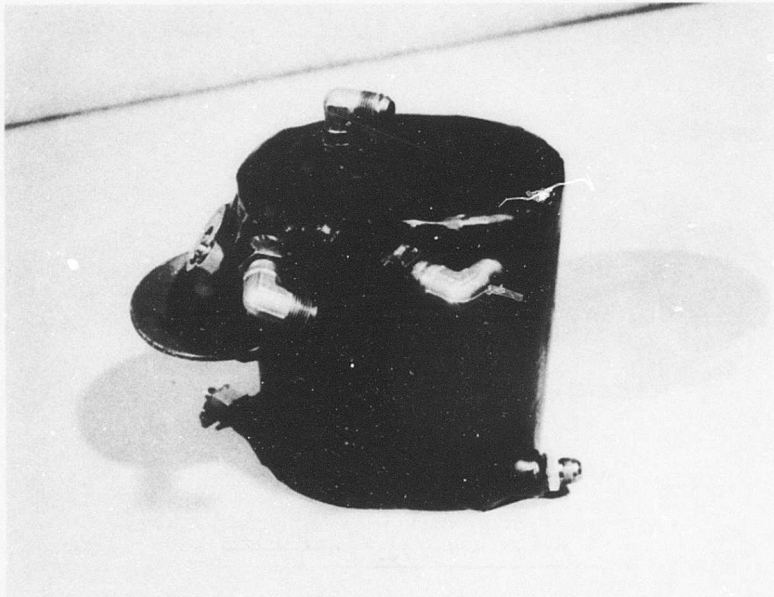
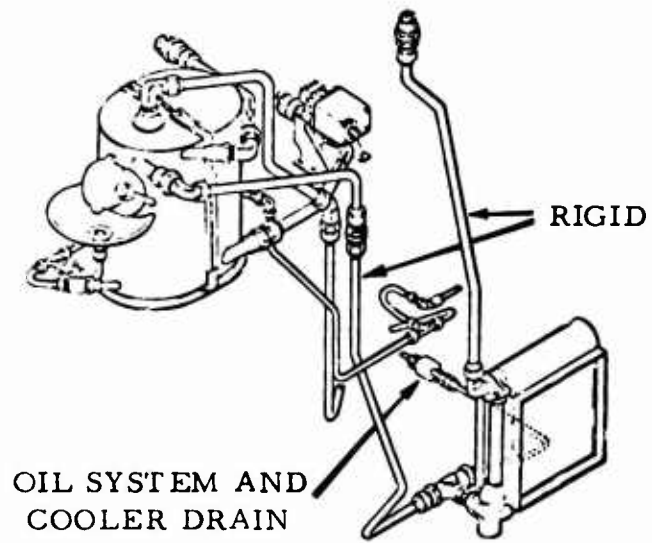

Figure 23. Oil Reservoir With Crash-Resistant Covering.

### Cooler

The standard UH-1A oil cooler installation placed the inlet and outlet fittings on the side of the cooler (Figure 24). In this position, the lower oil return line and fitting were extremely vulnerable to crash damage caused by the upward displacement of the

BEFORE



AFTER

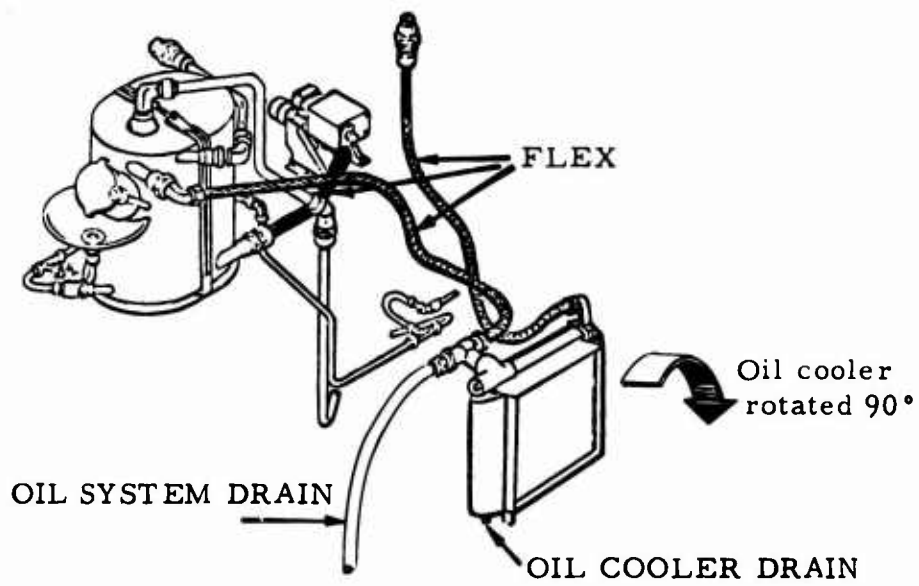

Figure 24. Oil Cooler Modifications.

airframe structure and the aft landing gear crossover tube. The cooler was rotated 90 degrees, placing the inlet and outlet fittings on top of the cooler as shown in Figure 24. The oil cooler could still be drained by using a conveniently located extra hole in the cooler.

### Lines

The following rigid aluminum oil lines were removed and replaced with standard steel-braid-covered flexible hose:

1. The oil line between the reservoir and the cooler.
2. The oil line between the service deck and the cooler.
3. The oil line between the reservoir and the firewall shutoff valve.

A check valve was installed in the oil line between the firewall shutoff valve and the reservoir. Should the engine be displaced in the crash, it was anticipated that this oil line would break free either at the engine pump coupling or on the engine side of the firewall shutoff valve. In either case, the check valve would prevent reservoir oil from draining onto the hot engine.

The engine-to-cooler flex line passed vertically through the service deck below the engine. A steel triggering valve mount was installed, and a self-sealing quick-disconnect coupling was placed in the line. The valve and mount operated in the same manner as the fuel valves discussed under Fuel Lines earlier in the report.

### Pressure Transmitter

The engine oil pressure transmitter was removed from its mounting pad directly on top of the engine and was relocated on another pad on the right side of the engine. This relocation was performed to reduce the vulnerability of the transmitter to damage and leakage if a roll-over-type crash were to occur.

### Transmission

The transmission oil pressure transmitter mounted on the upper right side of the transmission could be subjected to damage from many sources

in the event of a crash. The crash resistance of its connecting fluid line was improved by replacing it with a flexible metal line; see Figure 25. Flexibility in this line was achieved as the coils were compressed or extended.

The standard transmission-to-sump oil line was a rigid metal line. It was replaced with a flexible wire-braid-covered hose that could deflect and elongate under crash loading; see Figure 25.

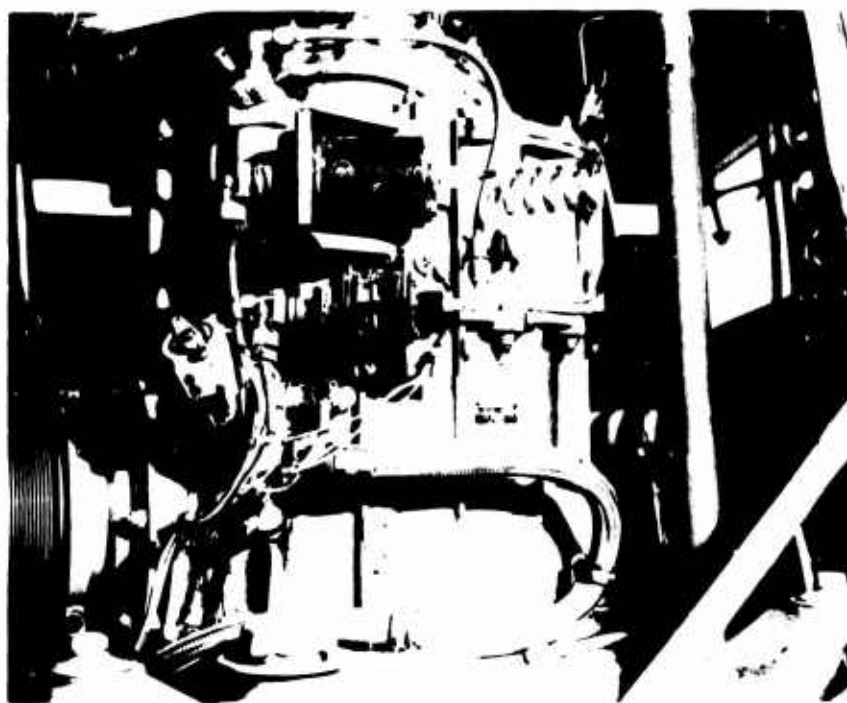

Figure 25. Transmission Oil Supply Area.

An experiment was conducted with the flexible metal line to evaluate the capability of the line to remain liquid-tight while being subjected to anticipated elongation. A coiled tube 9 inches long was rigidly attached to the base of the transmission sump and to the side of the helicopter airframe, as illustrated in Figure 26. The distance between the two connection points changed continually while the rotor system turned, because the transmission was free to pivot somewhat about its tiedown. During a crash, this 9-inch distance could increase considerably if the transmission were to be deflected.

#### HYDRAULIC SYSTEM

The major components of the hydraulic system were located in the center

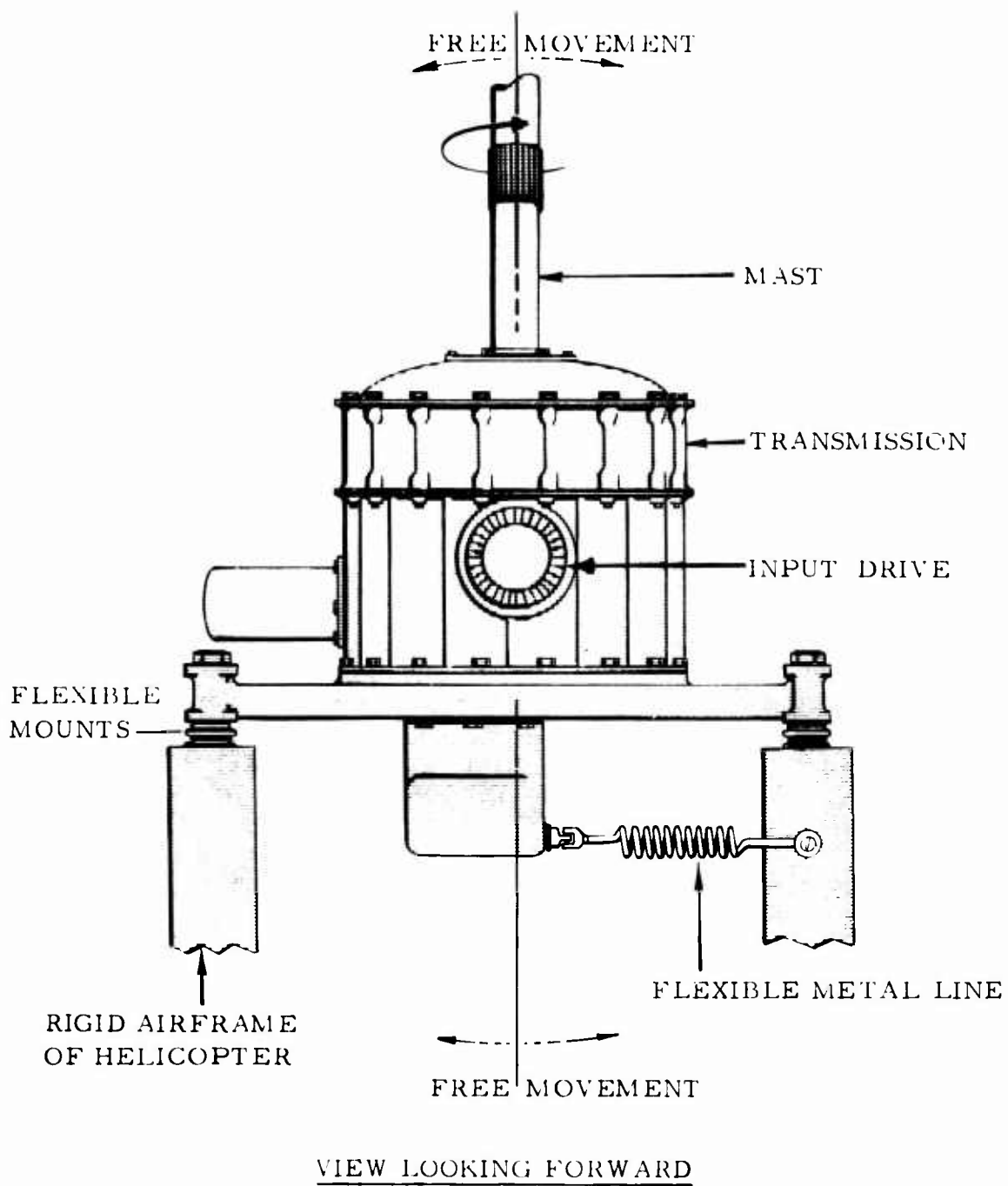

Figure 26. Transmission Schematic Illustrating Coiled Tube Experiment.

section of the helicopter. The reservoir and the ground test coupling were mounted on the forward firewall on the right side above the service deck, while the pump was installed nearby on the transmission. The only modification attempted on the hydraulic system was to install a flexible coiled line as a replacement for the rigid reservoir pressure bypass line. This line is visible at the right side of Figure 27.

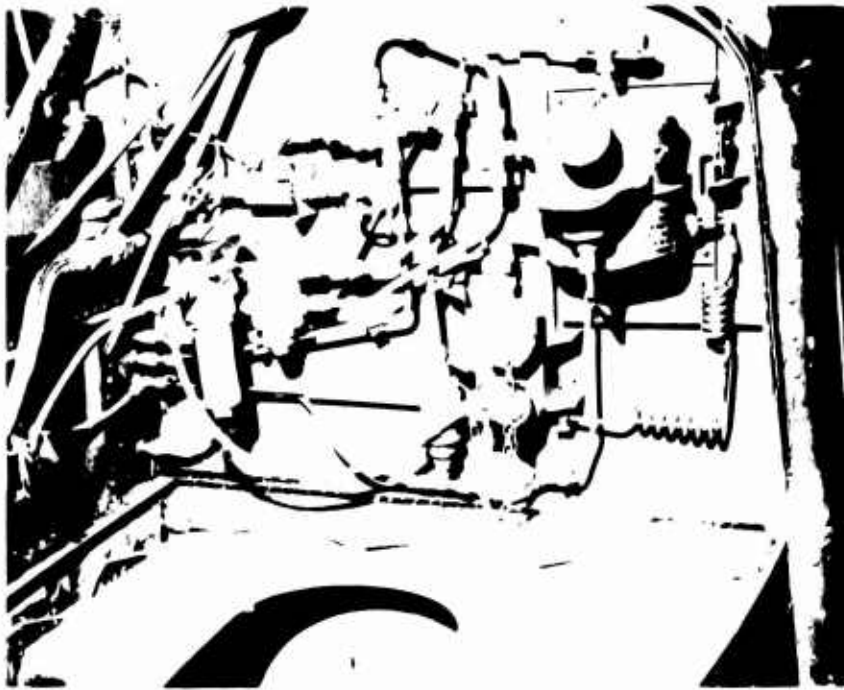

Figure 27. Hydraulic System Showing Flexible Metal Line on Right Side of Installation.

### ELECTRICAL SYSTEM

Electrical system components were located throughout the helicopter. The nature of the service performed by them also serves to provide an extreme ignition potential throughout the airframe. Many of the electrical components were installed in small sealed compartments surrounding the center portion of the helicopter and were in relatively protected areas. However, some of the components (namely, the battery, the boost pump, and certain wiring) required additional protection.

#### Battery

The weight (72 pounds) of the battery dictated that it be positively

restrained in its installed position. If it were to be released from its tiedown, it could destroy the surrounding compartment, short-circuit its connecting wires, and impinge on the fuel cell located just ahead.

To reduce the probability of release, the two retainer brass tiedown rods were replaced with steel rods. The two thin sheet-metal restraint brackets (see Figure 28) were replaced with four 6-inch-long aluminum angle clips. The four clips were bolted to the compartment shelf on which the battery was located.

### Boost Pump

The electrical wires normally exited the boost pump at the bottom of the fuel tank. Structural collapse in this area would allow the boost pump wires to be cut or broken. Abrading action of the underbelly's sliding across the terrain could also damage these wires and thus provide an ignition source. The original boost pump wire routing was particularly hazardous because it placed electrically energized wires in an area in which crash-induced fuel spillage was likely to occur.

The ignition hazard was greatly reduced by rerouting the boost pump wires. The pump was modified slightly, as shown in Figure 29, to allow the wires to exit inside the tank. The wires then traveled up through the fuel in a standard flexible hose. The hose was approximately 30 percent longer than would be normally required; thus, it could allow the fuel tank to rearrange its volume without placing tension loads on the hose and wires.

A terminal board was moved from a position beneath the left fuel cell to a position near the cell top on the framing around the cell cavity. Electrical wires for the boost pump, formerly routed beneath the cell, were rerouted to this board.

### Compartment Wiring

Wiring in the battery compartment deserved special attention since it was located in an area immediately adjacent to a fuel cell. Any fuel spillage from the cell was likely to come in contact with the wiring. Deformation of the compartment, under crash conditions, could place tensile loads on the wiring that would cause breakage; also, if the battery were to break free of its restraint, it could easily fail many wires.

Felt padding was used to insulate some of the lower mounted wires against impact or chafing contact with the helicopter structure. The

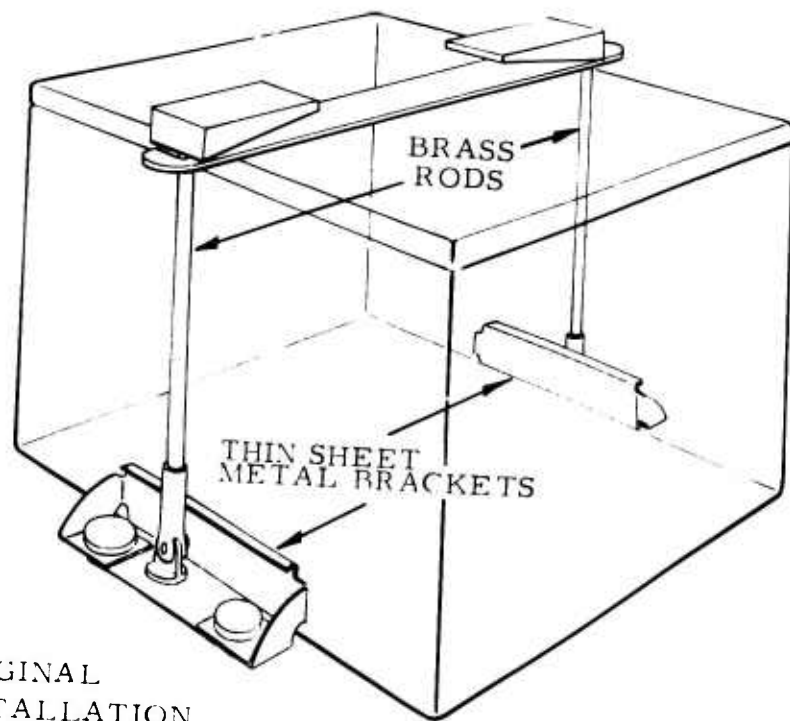

ORIGINAL  
INSTALLATION

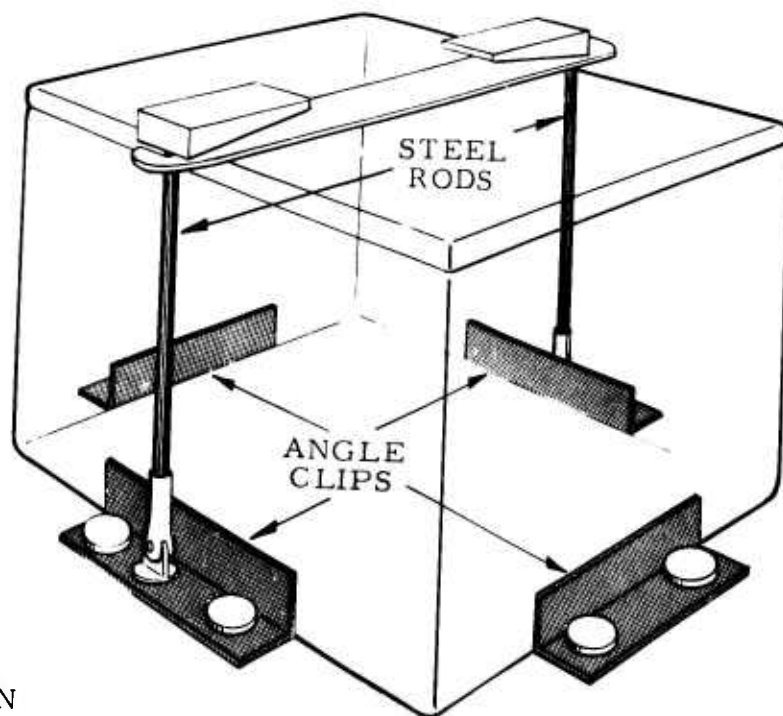

MODIFIED  
INSTALLATION

Figure 28. Battery Installation.

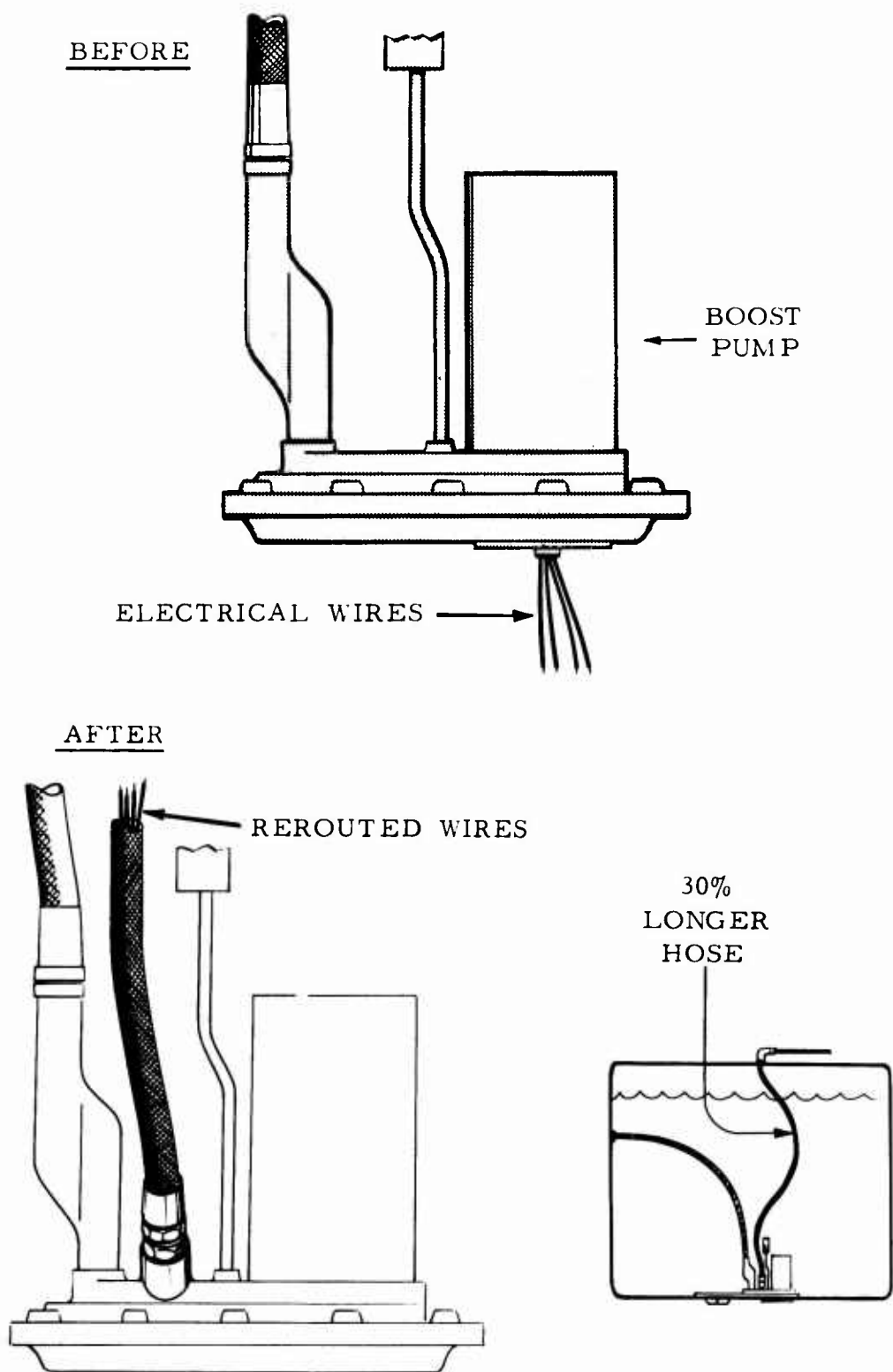

Figure 29. Boost Pump Modification.

padding, which was 1/2 inch thick, is shown in Figure 30.

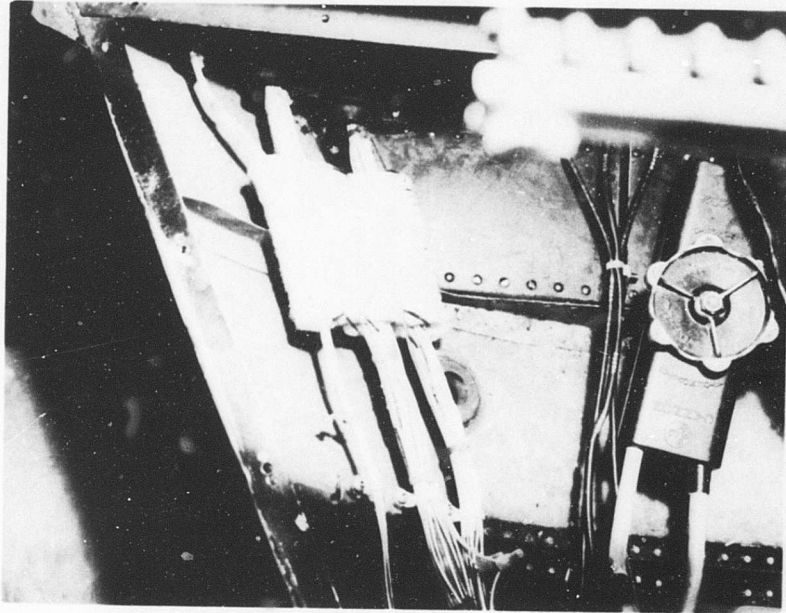

Figure 30. Insulated Wiring in Battery Compartment.

Metal loop-type cushioned clamps are normally used to secure the various wires, or bundles, to the helicopter structure. Unfortunately, these clamps hold the wires so securely that when structural displacement stretches the wires, the wires break. To prevent this breakage in areas of anticipated structural displacement, the wires were attached to the airframe structure with frangible nylon clamps. Each nylon clamp was capable of securely holding the wires during all conceivable flight and landing loads, but it would readily fail when loads were applied to it that approached the strength of the wires.

Nylon clamps were installed to replace 10 rigid clamps at selected locations in the battery compartment. Static and dynamic tests revealed that the nylon clamps would fail at loads below the tension failure point of the wires they held. A typical frangible clamp installation is shown in Figure 31. For detailed information concerning tests conducted with the frangible clamps and typical electrical wires, see Appendix VIII.

#### REMOTE FLIGHT CONTROL SYSTEM

The remote control system consisted of an airborne and a ground control

station linked by a transmitter and a receiver. The airborne package was designed to operate the three primary flight controls: collective, cyclic, and directional control pedals. The cyclic control and the directional control pedals were controlled by a gyro horizon and directional gyro. This feature provided automatic control of the pitch, roll, and yaw angles during the flight. The collective, preset during calibration flights, was actuated by the radio link to the ground control station. The rate of climb was adjusted by a collective vernier control, and level flight was initiated by a collective bias control, both of which are controlled from the ground station. In addition, minor correction of the lateral flight path could be made from the ground control station.

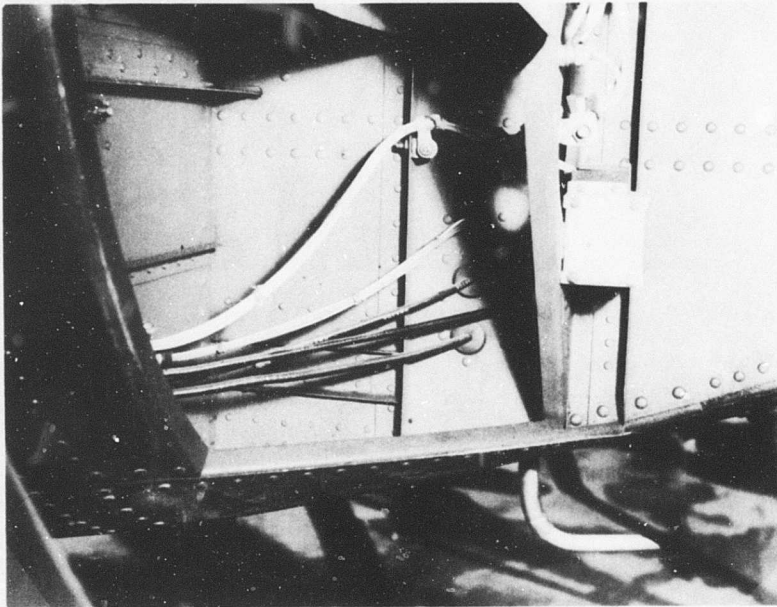

Figure 31. Frangible Wiring Clamp Installation.

### Helicopter Installation

The remote control system was mechanically connected to the flight controls by installing special hardware on the copilot's cyclic stick and directional control pedals. A special aluminum plate was designed and fabricated on which the servo actuators, cables, and pulleys were mounted, as shown in Figure 32.

A small panel was added to the pilot's cyclic stick to provide a mount for the pilot control switches for the remote control system (Figure 33).

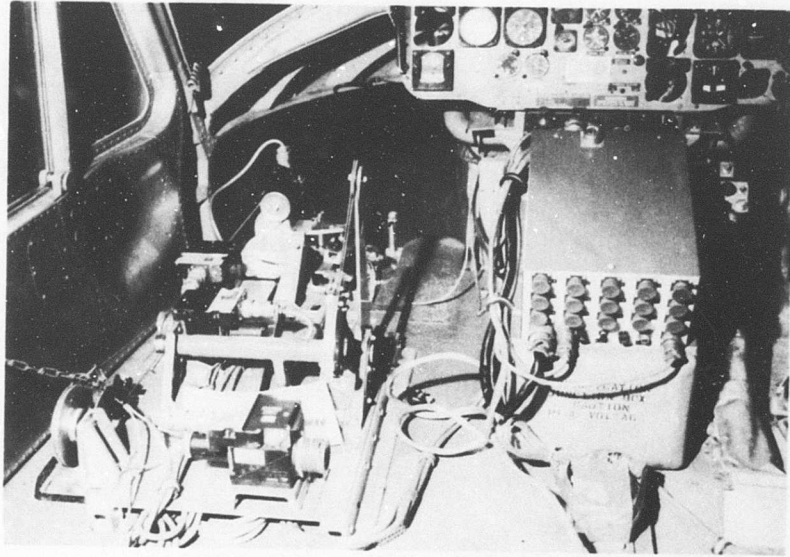

Figure 32. Remote Control System Installation and Connection to Copilot Flight Controls.

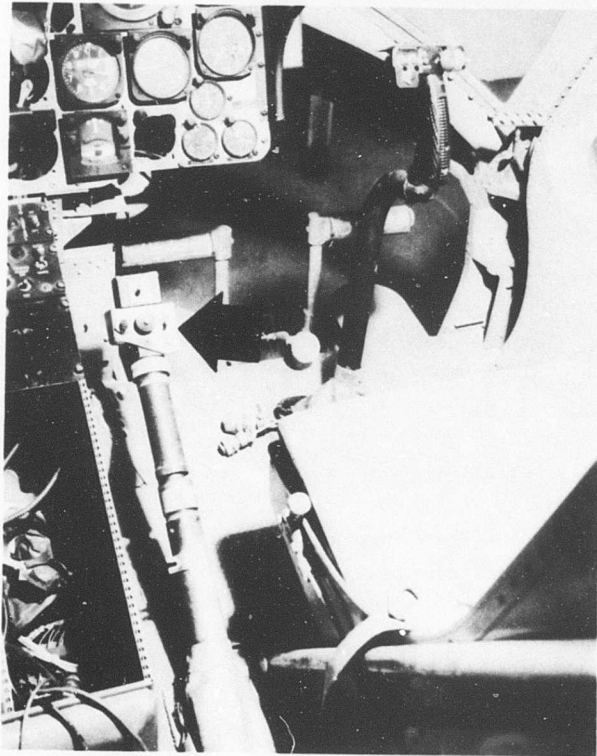

Figure 33. Pilot Control Switch Panel on Cyclic Stick.

The directional and attitude gyro assembly was mounted in the center of the cabin floor at Station 87, as shown in Figure 34.

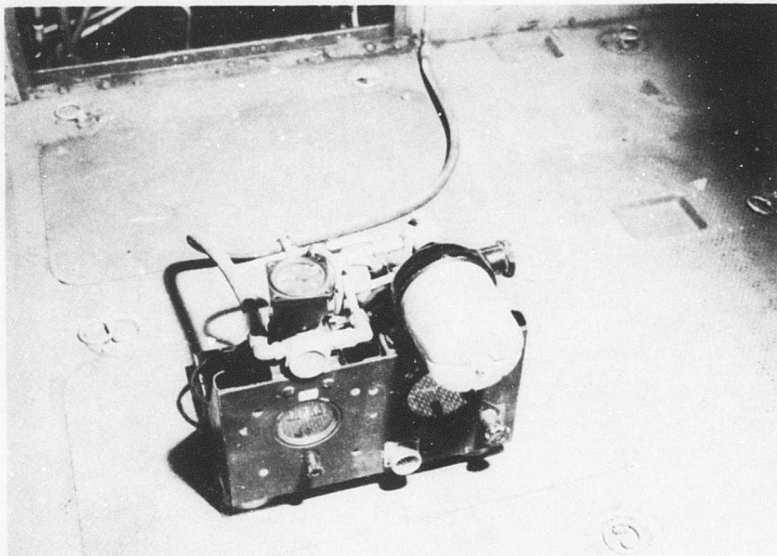

Figure 34. Gyro Installation.

### INSTRUMENTATION

Accelerations and temperatures were to be recorded during the test. The relative locations of the sensing instruments are shown in Figure 35.

Three Type A-5 Statham accelerometers, oriented triaxially, were installed on the aircraft floor between the crew seats in the cockpit.

Chromel-alumel thermocouples were installed to record temperatures at four locations in the cockpit and troop compartment, at six locations on the engine, at the rear of each fuel cell cavity, and between the cells.

A Photosonics model 1B high-speed camera was mounted above the remote flight controls installation at the copilot seat position. Color film was used, at 500 frames per second, to record the performance of an experimental seat (a separate experiment not covered in this report) and the general area surrounding the fuel cell. This camera is shown as Item 16 in Figure 35.

Thirteen movie cameras were positioned around the impact area to record the test flight and impact of the helicopter. Their relative positions are shown in Figure 36.

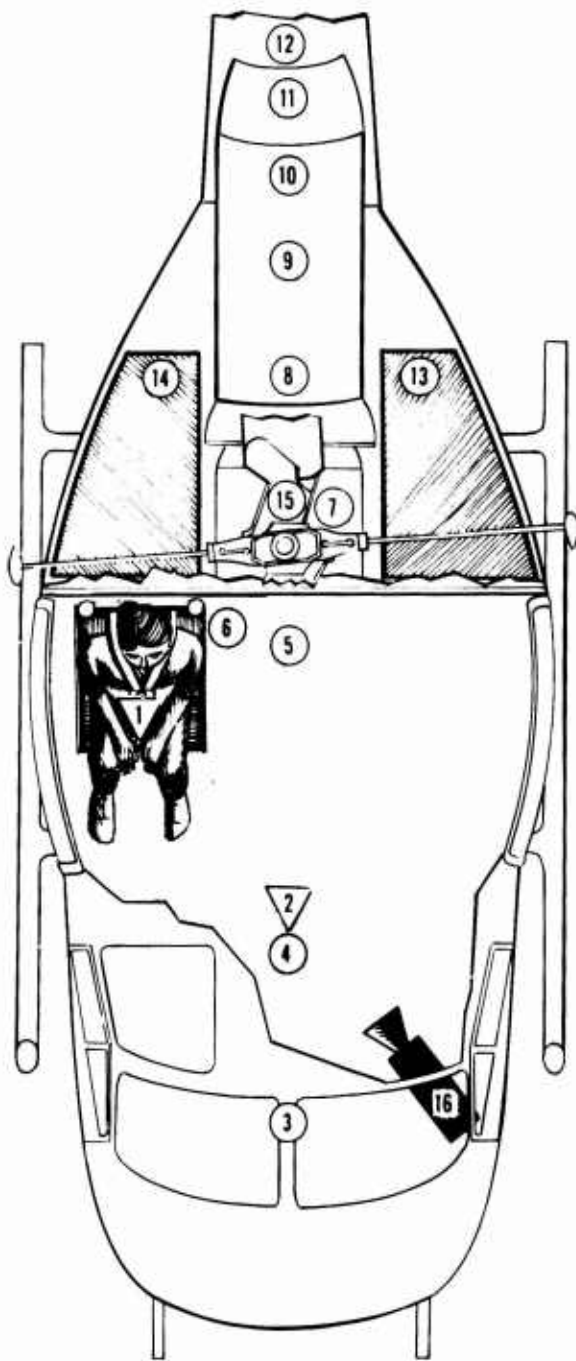

ACCELEROMETERS  
(TRIAXIAL INSTALLATION)

- ▽ DUMMY PELVIS
- ▽ AIRCRAFT FLOOR

THERMOCOUPLES

- ③ COCKPIT HIGH
- ④ COCKPIT LOW
- ⑤ TROOP COMPT HIGH
- ⑥ TROOP COMPT LOW
- ⑦ ENGINE INTAKE
- ⑧ ENGINE FORWARD
- ⑨ ENGINE CENTER
- ⑩ ENGINE REAR
- ⑪ TAIL PIPE
- ⑫ EXHAUST GAS
- ⑬ LEFT CELL AFT
- ⑭ RIGHT CELL AFT
- ⑮ BETWEEN CELLS

HIGH-SPEED CAMERA

- 16 500 FRAMES PER SECOND

Figure 35. Onboard Instrumentation.

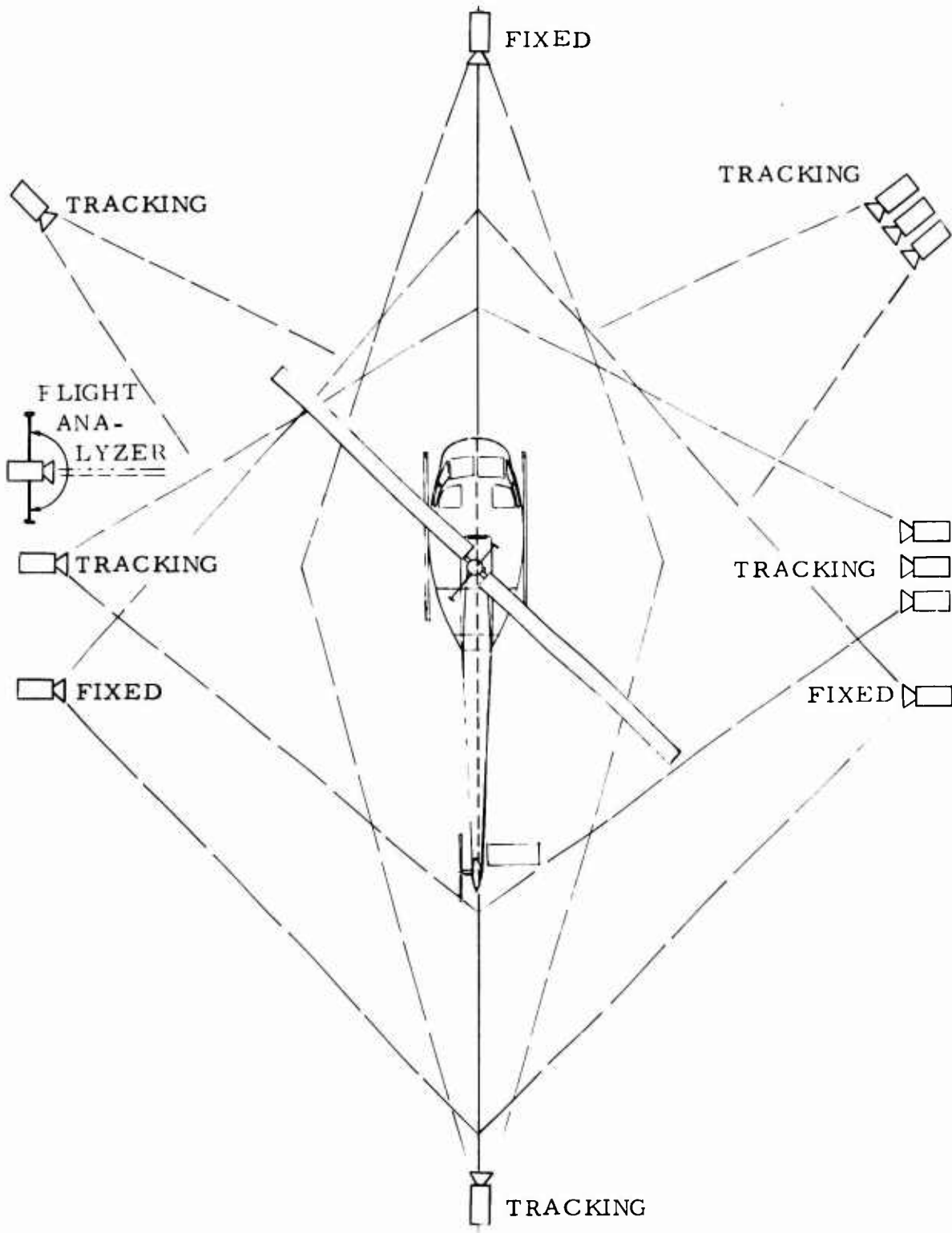

Figure 36. High-Speed Camera Locations.

### TEST CONDITIONS

The desired test conditions at impact were:

Horizontal Velocity	65 Feet Per Second
Vertical Velocity	40 Feet Per Second
Impact Angle	30 Degrees
Pitch Angle	± 20 Degrees
Roll Angle	± 10 Degrees
Yaw Angle	± 10 Degrees

Gross weight breakdown:

	<u>Pounds</u>
Helicopter	4000
Fuel (emulsion)	897
Seat Experiment	450
Instrumentation	250
Pilot (simulation)	170
Drone System	<u>50</u>
Gross	5817

## TEST OPERATIONS AND CRASH ANALYSIS

The helicopter was subjected to an intensive pretest quality control program to insure that the system modifications were operationally acceptable and that the problems of engine operation on emulsified fuel were resolved. A 1-hour test flight was accomplished at low altitude after the system modifications were completed. Ground engine operation on emulsified fuel came next, followed by a sustained hover at 4 feet. This part of the program took place over a 2-week period preceding the actual crash test date.

At 0845 hours on 23 February 1968, the helicopter was crash-tested by means of the radio-controlled flight system. The lift-off was normal, and the helicopter, in a 10-degree nosedown attitude, climbed to an altitude of approximately 65 feet. The collective pitch control was then bottomed, causing the aircraft to descend in a 250- to 300-foot-long glide path. Conditions at impact were:

Horizontal Velocity	81 Feet Per Second
Vertical Velocity	23 Feet Per Second
Impact Angle	15.5 Degrees
Pitch Angle	12 Degrees Nose Down
Roll Angle	0 Degrees
Yaw Angle	3 Degrees Left

After impact, the helicopter slid 189 feet. After sliding in a relatively flat attitude for approximately 90 feet, the forward portion of the helicopter dug into the ground, causing an overturning moment to be applied. This caused the helicopter to roll to the right for three-quarters of a turn, finally coming to rest on its left side. The tail boom was sheared off, as were both landing skids (Figures 37 and 38).

The main rotor blades remained attached to the rotor head. The main transmission, as well as the engine, broke free of all mountings and displaced leftward, as shown in Figures 39, 40, and 41. Most of the cabin roof was torn free, and the fuselage broke, nearly separating, where the aft passenger compartment vertical bulkhead joins the floor; see Figure 42.

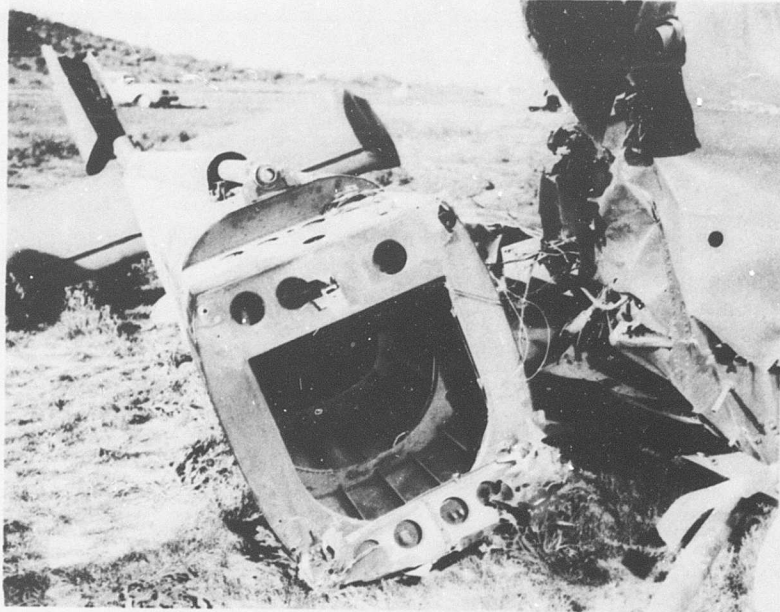

Figure 37. Tail Boom Broken From Fuselage.

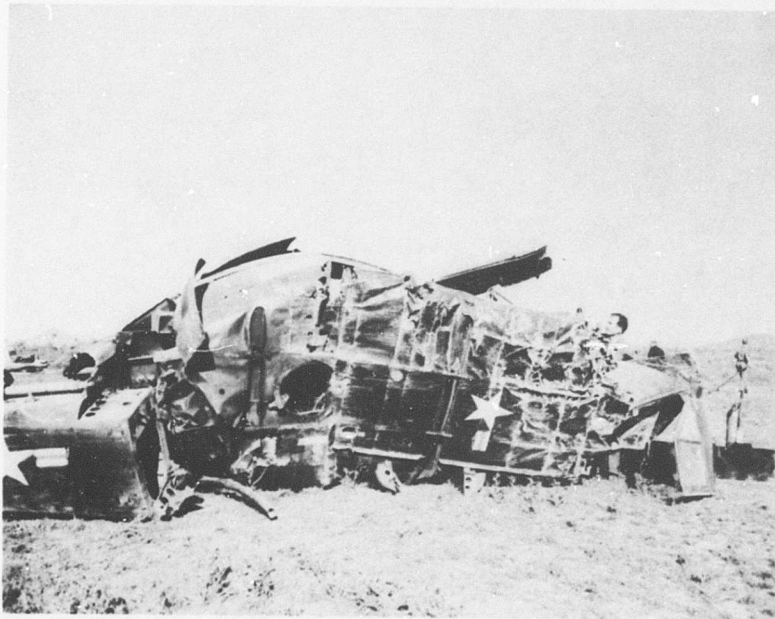

Figure 38. View of Helicopter Underside Showing Damage and Absence of Skids.

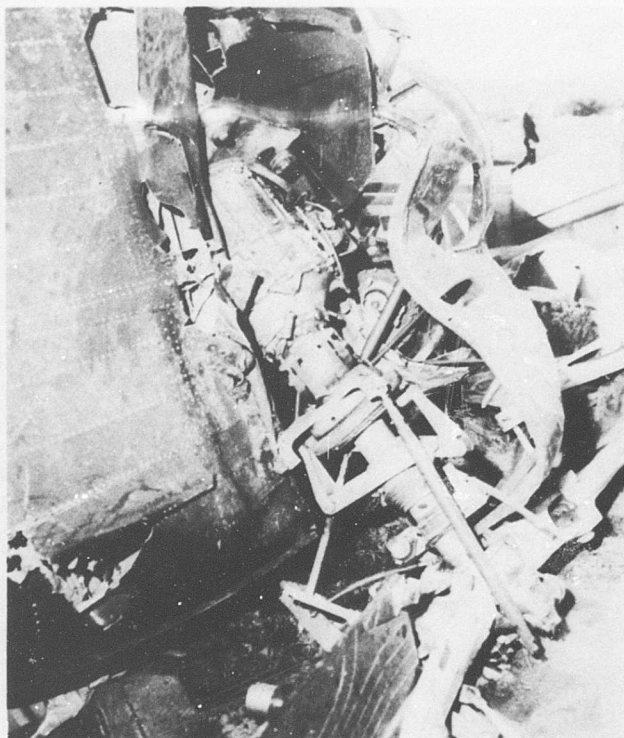

Figure 39. Main Transmission and Rotor Mast in Wreckage.

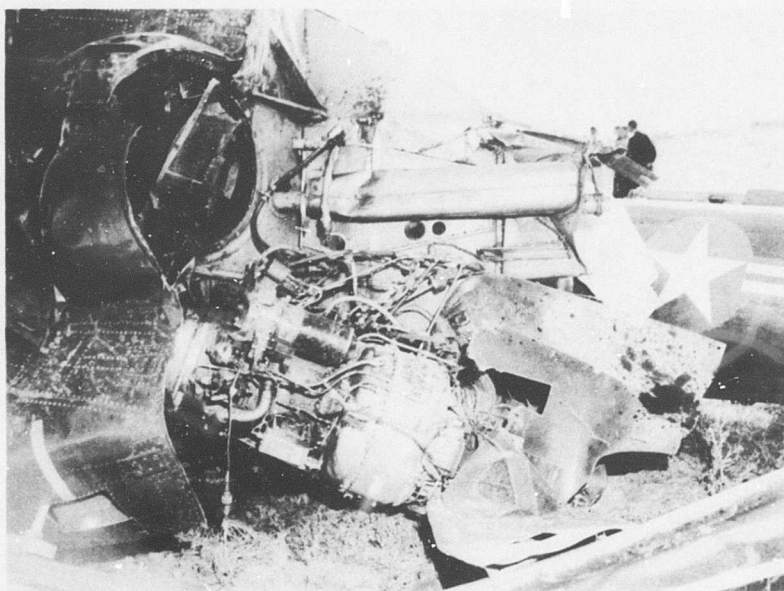

Figure 40. Postcrash Position of Engine.



Figure 41. Position of Main Rotor Blades in Wreckage.

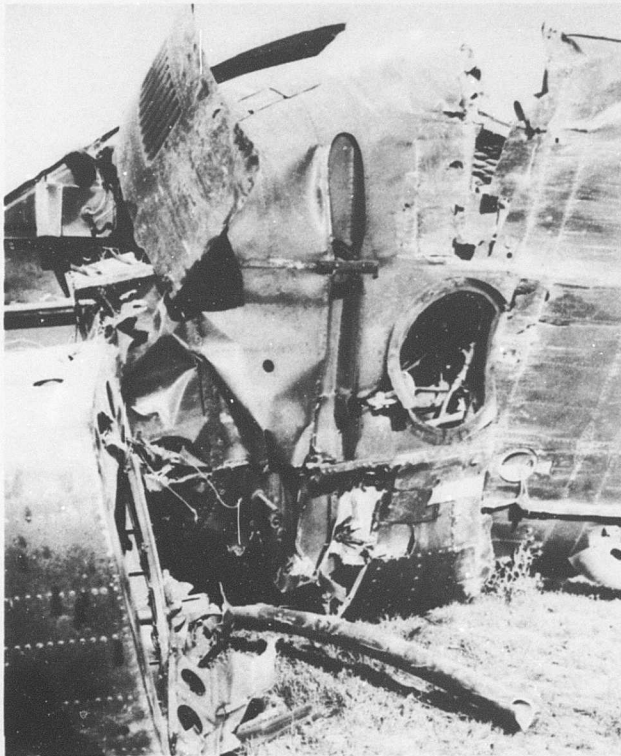

Figure 42. Bottom View of Fuselage Break.

There was no fire on impact, during the slide, or when the helicopter came to rest.

There were some flammable fluids released into the crash area from transmission and hydraulic system failures. The spillage was not considered to be particularly hazardous and will be discussed in the following section.

## TEST RESULTS

### FUEL SYSTEM

All of the system experiments functioned satisfactorily. No fuel was spilled at any time during the crash sequence or the follow-on investigation.

#### Fuel Tank

The crash-resistant fuel tanks were not punctured, nor did they release their fuel load at any point. A bottom corner of the right cell was gouged when the supporting structure surrounding it failed and then displaced back and forth against the corner; see Figure 43. No other damage to the fuel cells was discovered. The tank system is shown re-assembled in Figure 44, a photograph taken after the cells were removed from the wreckage.

#### Triggering Valve Mount

The valve mounts were undamaged during the crash. They were leak-checked for several days after the crash, and no seepage could be detected.

#### Wedge-Lock Retainer

The two wedge-lock retainers performed as designed. They securely held the frangible interconnects, preventing fluid seepage during the crash and the subsequent leak check.

#### Boost Pump Mounting Diaphragm

The mounting diaphragm operated satisfactorily during the crash. It protected the sump drains from the rock-simulated rough terrain and prevented diaphragm failure in the boost pump area.

#### Crossover Tubes

The aft crossover tube, made of flexible crash-resistant material, remained intact and can be seen in Figure 44. The aft tube was not displaced; consequently, the frangible interconnects at each end did not receive the necessary force to make them separate. The forward crossover tube, made of flexible hose, was intact and the valves were still attached to the tank.

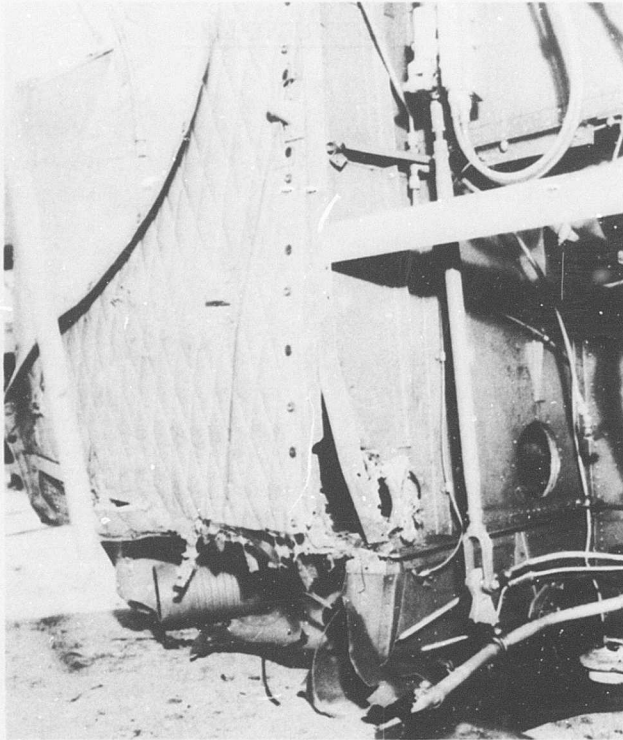

Figure 43. Deformed Structure and Exposed Fuel Cell.

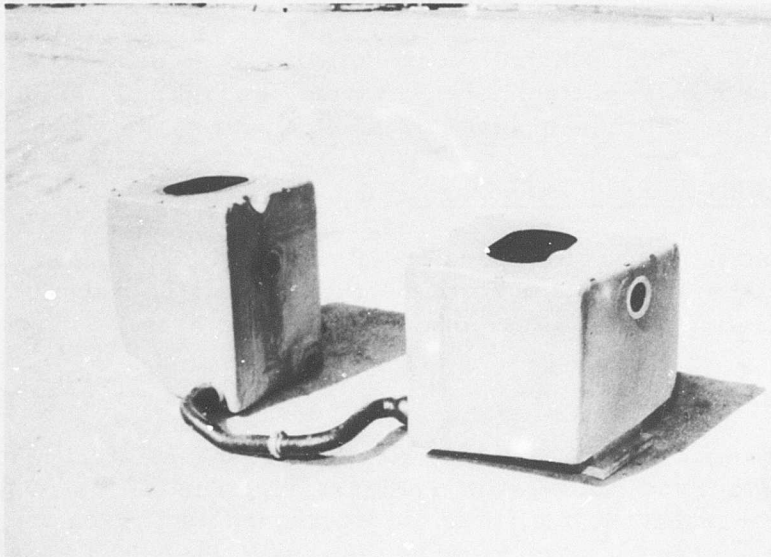

Figure 44. Tank System and Aft Crossover Assembly Reassembled After Test.

### Fuel Lines

All flexible fuel lines functioned as designed. During the crash, the engine was displaced to the left for a distance of several feet, placing a tension/bending load on the two fuel lines that passed through the service deck. The movement caused separation in the quick-disconnect fittings; see Figure 45. No fluid spillage occurred. The severance of the main fuel supply line initiated engine shutdown.

The load transfer cable on the fuel control vent line functioned satisfactorily, protecting the small 1/4-inch elbows from failure.



Figure 45. Service-Deck-Mounted Triggering Valve Mounts Shown After Fuel (Arrow 1) and Oil (Arrow 2) Lines Separated at Impact.

### Fuel Valves

All fuel valves functioned as designed. The three quick-disconnect valves and the interconnect couplings mounted in the fuel tanks survived the crash without separation. The fact that they did not separate is indicative that:

1. The load applied to the valves was not great enough to cause separation. The fact that they will separate during a crash

when the loads are high enough has been clearly demonstrated in previous tests; see Appendixes I and IX.

2. More reliance can be placed on the breakaway valve concept since the hazards of inadvertent separation during normal flight conditions and under crash loading appear to have been eliminated.

The three modified quick-disconnect valves located at the service deck separated and sealed themselves. The functioning of these valves was considered to be a major safety contribution in the crash test. Had any of them failed to separate or seal, a crash fire would most likely have occurred.

### Structural Attachments

The three frangible attachments functioned satisfactorily during this experiment. Prior to the crash, the attachments supported their respective components in a satisfactory manner. During the crash, they all received some loading; however, it was not severe enough to cause separation. There were no related or adjoining system failures caused by the fact that the frangible attachments did not separate.

The frangible ring located at the filler neck showed some evidence of load application; however, the load was considerably below that required to cause a complete separation.

The fiber glass tank wall stabilizer also showed some signs of loading. The loading was more severe than for the ring, but it was still well below the failure point.

The boost pump area was impacted from below by the large rock (Figure 46). As the rock moved upward, it penetrated the outer aluminum skin, contacting the boost pump mounting diaphragm and the fiber glass/honeycomb helicopter structure comprising the cell cavity bottom. The honeycomb panel was displaced upward several inches by the rock. The tank area surrounding the boost pump moved upward with the cavity floor; consequently, there was no displacement between the tank and the helicopter structure. The frangible aluminum screws were apparently not loaded; thus, they were not called upon to separate.



Figure 46. Postcrash View of Boost Pump Installation.

#### ENGINE

The engine was successfully operated on emulsified fuel during this test program. It was first test-flown and then crashed as a separate experiment.

Pertinent observations were as follows:

1. Since the engine had to be started on liquid fuel, and the RPM maintained above 75 percent for successful change-over to the emulsion, an auxiliary fuel system had to be built which could be turned off and on and fed into the normal fuel system at will.
2. Since changeover to emulsion caused the main rotor blades to drop 50 RPM, the fuel control had to be readjusted slightly.
3. The screen in the main airframe fuel filter had to be removed to allow for a greater fuel flow.
4. The standard fuel control filters functioned satisfactorily, requiring no substitutions. A photograph of the removed filters, after the test flight on emulsion, is presented in Figure 47.



Figure 47. Engine Fuel Control Filters After Test Flight on Emulsified Fuel.

Thermocouples were placed in several locations on and around the engine. Temperatures were measured during starting, during ground operations, and in flight, with both the liquid fuel and the emulsion. There were no measurable differences in temperature.

One observation was made that might be of future interest. When the aircraft was operating on emulsion, the fuel which exited the fuel control via the vent return line was in a liquid state rather than in an emulsified state. Since this return line empties into the forward crossover tube, in effect liquid fuel was displacing emulsion in an area where severe impact and displacement could be anticipated.

#### LUBRICATING OIL SYSTEM

All lubricating oil system experiments functioned satisfactorily. No engine oil was spilled in the crash sequence or the follow-on investigation. Some main transmission oil was spilled, but it was of small quantity and not considered to represent a serious ignition potential.

## Engine

### Reservoir

The oil reservoir, sheathed in the felt cover, sustained a severe blow at the top. The aluminum container was compressed downward for 1 inch, and a 2-inch opening occurred in a welded seam. Oil spilled into the felt, but external leakage was prevented by the polyurethane surfacing; see Figure 48.



Figure 48. Crushed Oil Reservoir.

### Cooler

The rotated oil cooler and its protruding fittings were not damaged, even though 20-percent crushing occurred in the structure beneath the installation. Had the cooler been in its original position, impact damage to the fittings would have been likely and considerable oil spillage would have occurred.

### Lines

All flexible oil lines functioned as planned. The engine-to-cooler line, which passes through the service deck, separated and sealed at both ends. The engine-to-reservoir line broke free at the engine-driven pump (see Figure 45); however, fluid loss from the reservoir was prevented by the check valve.

### Pressure Transmitter

The transmitter remained intact in its new side-mounted location and survived the crash without permitting spillage. Had it been left on top of the engine, it is likely that it would have been knocked off, resulting in pressurized oil spillage.

### Transmission

The transmission was torn free of the airframe basic structure. It displaced laterally several feet at the rotor end and 8 inches at the sump. The main case casting failed at the tiedown point, releasing the case fluid. The fluid was spilled throughout the cargo hook area but was not in evidence above the service deck. All oil line experiments conducted with the transmission were successful in that leakage did not occur.

The flexible oil line placed between the transmission case and the lower sump was displaced, elongated, and crushed in several areas as the transmission moved laterally within the airframe (Figure 49). The flex line held, preventing any spillage.

The flexible metal line installed on the transmission-mounted oil pressure transmitter remained fluid-tight as the transmission was broken from the mounts. Both the line and the transmitter installation can be seen in Figure 49.

The flexible metal line installed between the transmission sump area and the airframe structure extended the 8 inches required to accommodate the displacement and was subjected to a variety of impacts from the surrounding structure and loose objects. The line was stretched, crimped, and compressed in several locations; however, it was still attached to the transmission and to the airframe and was liquid-tight; see Figure 50.

### HYDRAULIC SYSTEM

Oil was released from the hydraulic system during the crash. The reservoir (Figure 51) sustained a 3/4-inch V-puncture, causing the loss of about one pint of fluid. The two flexible lines that connect the hydraulic system with the pump were broken at the pump fitting (Figure 52), spilling about one pint of fluid from the lines.

The flexible metal line (Figure 51) was not subjected to any gross displacement; however, it was bent slightly. Its full capacity to deform or elongate was not required during the crash.



Figure 49. Postcrash View of the Transmission Area.



Figure 50. Coiled Metal Line Experiment.



Figure 51. Postcrash View of Hydraulic System.



Figure 52. Hydraulic Pump Broken From Transmission Mount. (Arrows indicate broken (1) pump and (2) fittings.)

## ELECTRICAL SYSTEM

All of the electrical modifications functioned in the desired manner. The battery did not move from its tiedown point. The wires directly below the battery and similar wires in the compartment to the rear of the battery were still intact. Seven of the frangible clamps holding the wires broke, allowing the bundles to move with the structure (Figure 53) rather than to remain rigidly attached and be broken. The felt insulation placed around three bundles of wires in the battery compartment successfully shielded the wires from the collapsing structure.

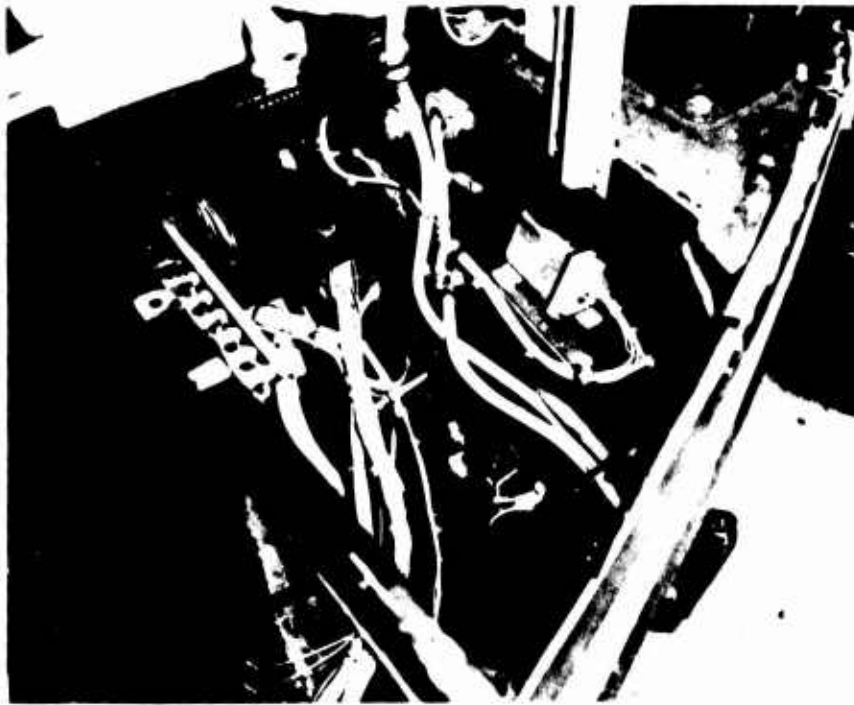

Figure 53. Electrical Wires Separated From the Frangible Clamps.

## REMOTE CONTROL SYSTEM

The remote control system functioned as designed, stabilizing the helicopter throughout its flight profile. During the final descent, the helicopter tended to glide farther than it did during the initial test flights. The possibility that the collective pitch control might not have fully bottomed was explored. However, postcrash tests indicated that it was in the fully bottomed position. At present, there appears to be no satisfactory explanation for the extended glide path of the test helicopter.

## INSTRUMENTATION

Unfortunately, during this test, the airborne recording oscillograph sustained a power failure between lift-off and the final crash. A thorough postcrash investigation of the equipment failed to disclose a component failure. The recorder was returned to the laboratory and the circuitry was bench-checked. It proved to be satisfactory. Investigation disclosed that the battery used to power the system was discharged to a point where it would not power the inverter, which in turn powered the recorder. A recheck of the crash procedures revealed that there had been several slight delays caused by last-minute adjustments to the remote control system. Each delay was followed by a recalibration of the sensing instruments. These recalibrations, coupled with a slight delay at lift-off, caused the battery charge to drop below the required power output during the crash.

## FOLLOW-ON TEST

Following the full-scale crash test, the crashworthy systems were reinstalled in the center section of the fuselage and were dropped from a drop tower. This test, yielding additional information in that forced separations of the many breakaway components was achieved, is presented in detail as Appendix IX.

## CONCLUSIONS

The following conclusions were drawn as a result of this test program:

1. Crash-resistant fuel and oil systems can be built today that will prevent flammable fluid spillage in crashes above the human survival range.
2. The possibility of inadvertent breakaway valve actuation during flight is doubtful. (Every valve not called upon to separate by load or displacement requirements during this test remained in its original position.)
3. Properly mounted quick-disconnect type fittings will prevent fluid-line failure, thus reducing the probability of spillage during crashes.
4. The use of steel-braid-covered flexible hoses in lieu of conventional rigid lines will prevent fluid loss during crash environments.

## RECOMMENDATIONS

Based on the results of the test program, it is recommended that:

1. The "Crash Survival Design Guide", the manual which dictated many of the crashworthy features demonstrated in this crash test, be continually updated and disseminated throughout the aviation industry.
2. More definitive data be obtained on frangible attachments and couplings. This field is virtually unexplored, and benefits could be gained by a thorough investigation.
3. Specifications that govern the design and utilization of frangible materials, crash valves, and interconnects be prepared and distributed throughout the aviation industry.

### LITERATURE CITED

1. Turnbow, J. W., et al, CRASH SURVIVAL DESIGN GUIDE, AvSER, A Division of Flight Safety Foundation, Inc.; USAAVLABS Technical Report 67-22, U. S. Army Aviation Materiel Laboratories, Fort Eustis, Virginia, July 1967, AD 656621 (Revised December 1967, AD 670955).
2. Robertson, S. Harry, and Turnbow, James W., AIRCRAFT FUEL TANK DESIGN CRITERIA, AvSER, A Division of Flight Safety Foundation, Inc.; USAAVLABS Technical Report 66-24, U. S. Army Aviation Materiel Laboratories, Fort Eustis, Virginia, March 1966, AD 631610.
3. Cook, R. L., Huyett, R. A., and Baker, R. E., IMPROVED CRASH-RESISTANT FUEL CELL MATERIAL, Goodyear Aerospace Corporation; USAAVLABS Technical Report 67-6, U. S. Army Aviation Materiel Laboratories, Fort Eustis, Virginia, April 1967, AD 813165-L.

APPENDIX I  
FLEXIBLE TRIGGERING VALVE MOUNT TESTS  
(TANK MOUNTED)

---

OBJECTIVE

A series of tests was conducted to determine if a quick-disconnect fitting would function as a fuel line breakaway valve if it was installed in a flexible type triggering mount.

TEST ITEM

The test item was comprised of a self-sealing quick-disconnect valve (see Figure 15) installed in a special Dynamic Science-designed triggering valve mount. The flexible mount is shown in Figure 54, and the method by which any pulling action on the protected line is converted to a tension load is illustrated in Figure 55.

TEST METHOD

The test item was installed on a special mount that extended behind a 3/4-ton truck. Figures 56, 57, and 58 show the experiment/truck installation and the mounting methods used for obtaining tension, 45-degree, and shear/bending load application. Figure 59 is a schematic of the load application modes. The truck was driven at 30 and 70 miles per hour, depending upon the test condition, over a ground-anchored cable snare device. As the truck passed over the cable, the snare coupled with the linkage attached to the quick-disconnect valve, thereby imposing rapid loading on the valve.

Thirteen tests were conducted: two in tension, two in the 45-degree mode, and two in a tension/bending combination for each speed, plus one extra test in the 45-degree mode at 70 miles per hour.

INSTRUMENTATION

A high-speed camera, mounted on the truck bumper, recorded the kinematics of the valve and tank material during separation.

RESULTS

Results of the 13 tests are presented in Table I.

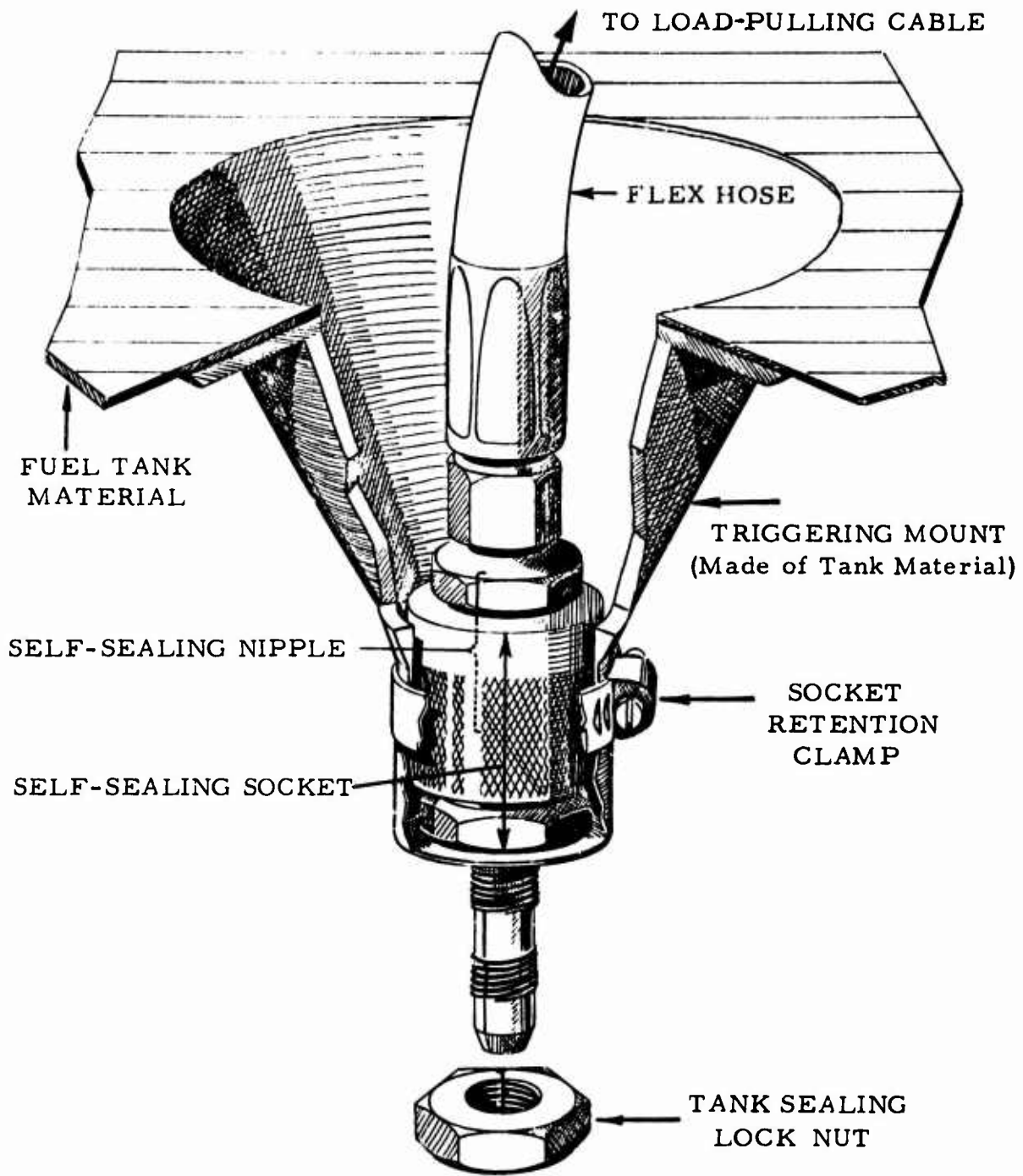

Figure 54. Flexible Triggering Valve Mount.

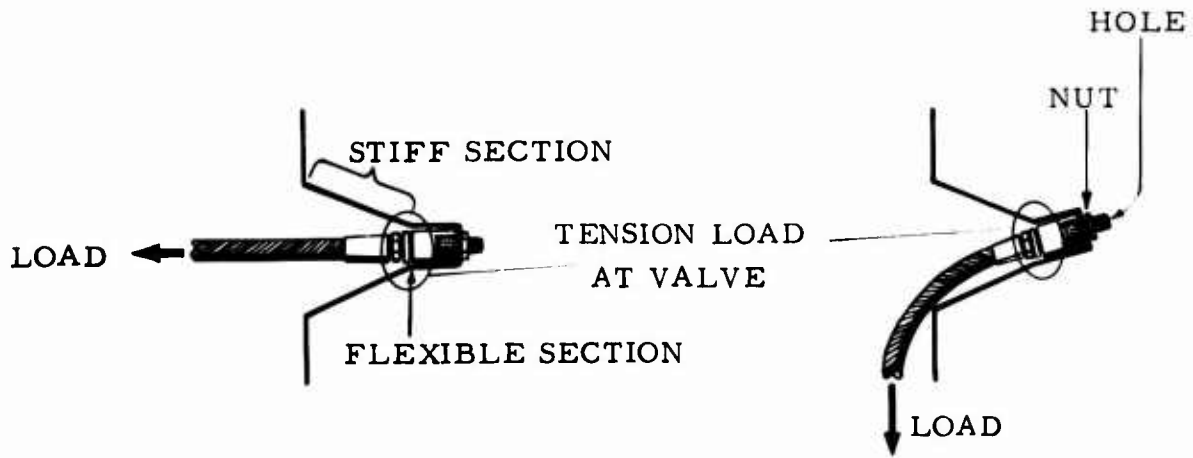

Figure 55. Method for Converting Off-Center Loads to Straight Tension Loads.



Figure 56. Valve and Trigger Mount Oriented for a Pure Tension Load Application.



Figure 57. Valve and Trigger Mount Oriented for a 45-Degree Load Application.



Figure 58. Valve and Trigger Mount Oriented for a Shear/Bending Load Application.

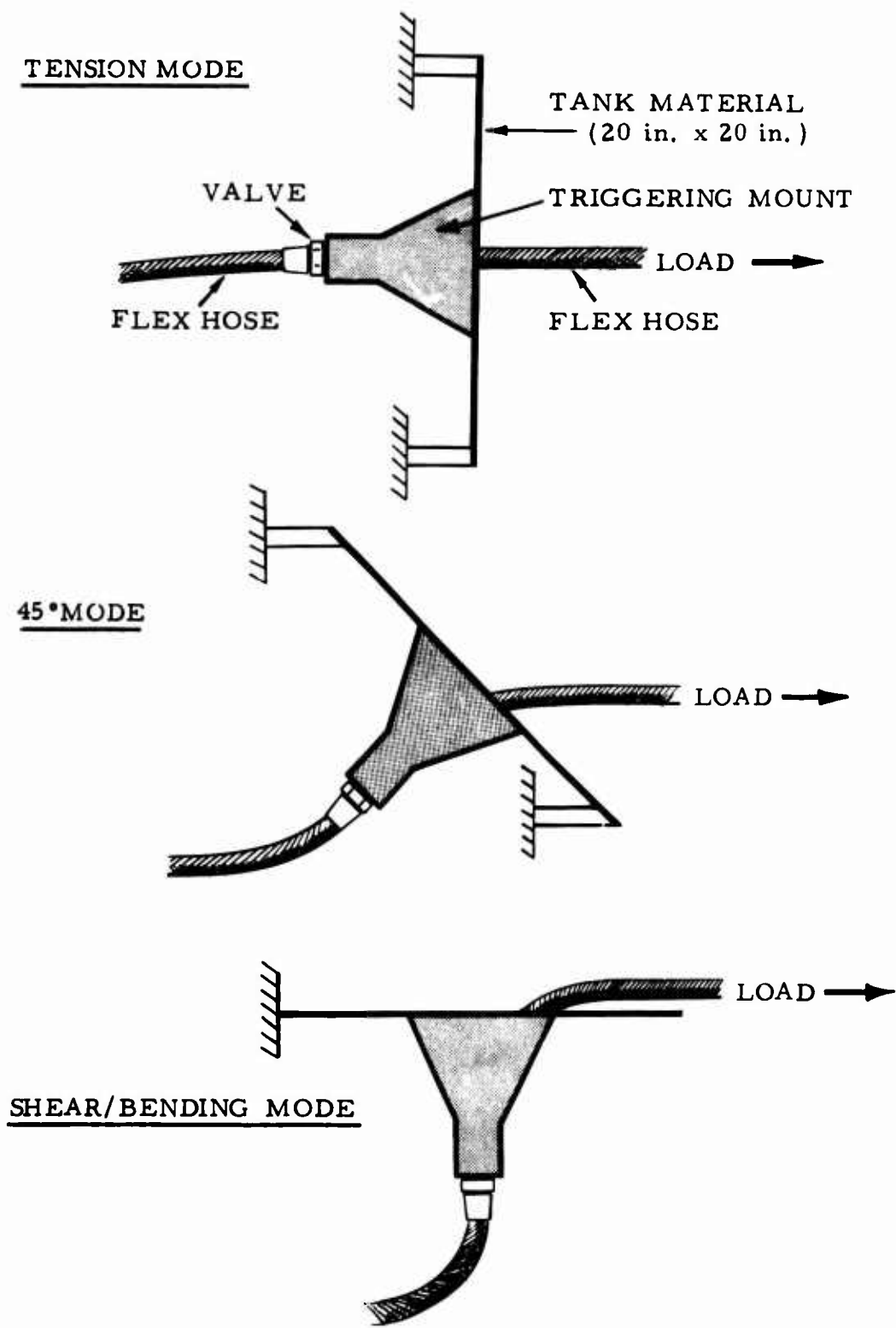

Figure 59. Schematic of Load Application Modes for Tank-Mounted Triggering Valve Mount and Self-Sealing Quick-Disconnect Valve.

TABLE I. FLEXIBLE TRIGGERING VALVE MOUNT TESTS

Run No.	Type of Test			Speed (MPH)	Separation
	Tension	45-Degree	Shear/ Bending		
1	X			30	Yes
2	X			30	Yes
3	X			70	Yes
4	X			70	Yes
5		X		30	Yes
6		X		30	Yes
7		X		70	No*
7A		X		70	Yes**
8		X		70	Yes
9			X	30	Yes
10			X	30	Yes
11			X	70	Yes
12			X	70	Yes

\* The aluminum nipple bent in the socket and jammed. The connecting hose pulled out of the fitting.

\*\* Stainless-steel nipples were substituted for the remainder of the test series. There were no further jamming tendencies.

CONCLUSION

As a result of these tests, it was concluded that a quick-disconnect type fitting could be used as a breakaway valve, provided it was installed in a flexible mount that would convert shear/bending loads to tension loads at the valve.

## APPENDIX II HIGH-STRENGTH TANK FITTING

### BACKGROUND

Fuel is often spilled during a crash when a molded-in tank fitting is torn from the tank. The standard fitting is restrained in a tank at about 200 pounds of strength per inch of fitting circumference. Even with standard .30-caliber self-sealing fuel tanks, this is only one-third the tank wall strength. New tank materials are approximately four times stronger than the present tanks. In order that the fittings not be pulled free of the tank until actual tank wall failure occurred, completely new fitting retention methods had to be developed.

### PROBLEMS BEARING ON DEVELOPMENT

Tank fitting tear-outs occur as a result of poor load transfer between crash-resistant bladder-type fuel cells and their various attachments. This problem stems from the fact that the reinforcement materials used in fuel cells have a much higher strength in tension than in interlaminar shear or bearing. An example of this problem is illustrated in Figure 60. In cases where the combination of bearing and shear strength is attempted, progressive failure of the bond usually occurs before the pins are loaded. Also, the use of bearing holes creates stress risers in the cell wall, which usually result in tearing after the load transfer mechanism has failed. Figure 61 illustrates this problem.

All of the problems mentioned are easily eliminated by the use of fittings which are designed to give a highly uniform load transfer equal to the basic material strength. Two such fittings are the wedge-lock and fiber-lock fittings discussed below.

### WEDGE-LOCK FITTING

The wedge-lock fitting is shown in Figure 62, and several applications of this device are shown in Figure 63. Wedge inserts have been made of metal, of wood, and of fiber reinforced elastomer. All materials have demonstrated a capability to sustain high compressive loads without danger of extrusion. The basic wedge can be made into as many segments as necessary to transfer the load throughout the laminated structure.

Wedge-lock samples were tested statically and dynamically to validate the retention concept. The static tests were conducted on an Instron

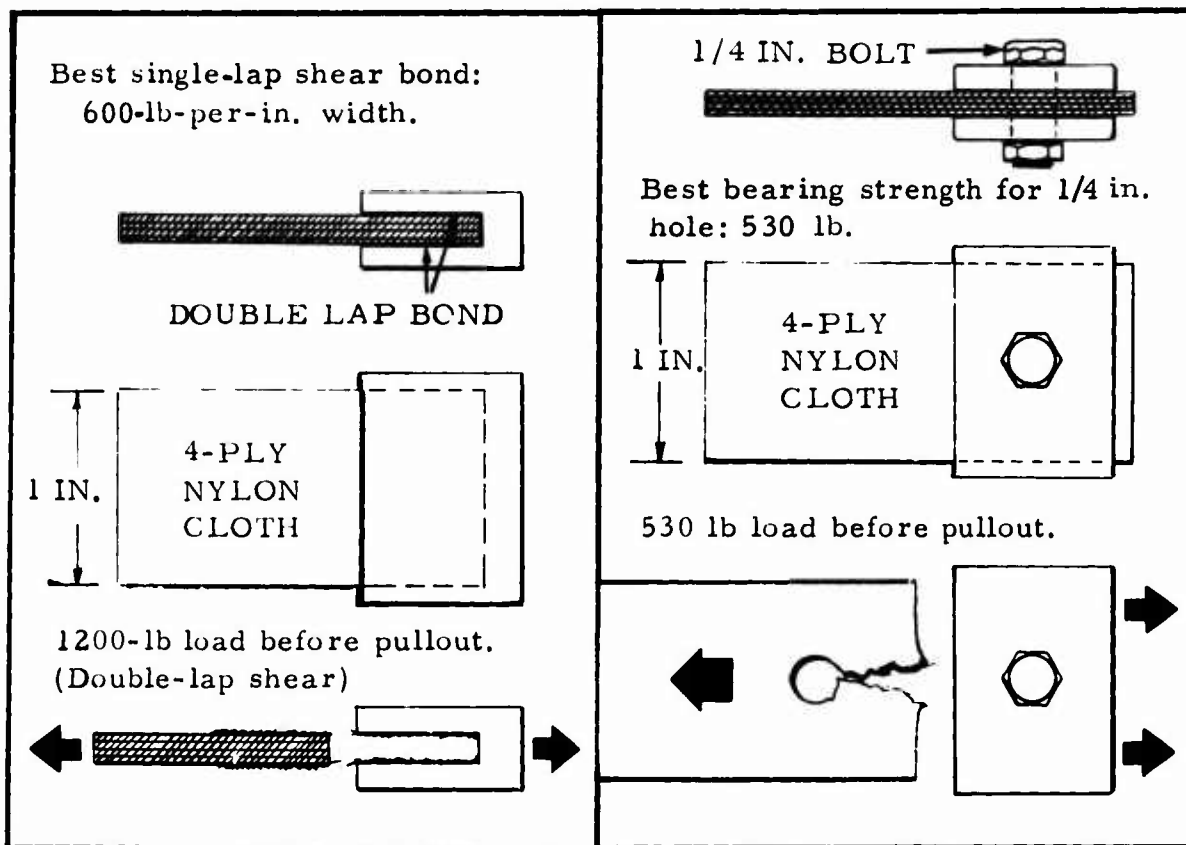

\*Basic material tensile strength - 2800-lb-per-in. width.

Figure 60. Conventional Load Transfer Methods.

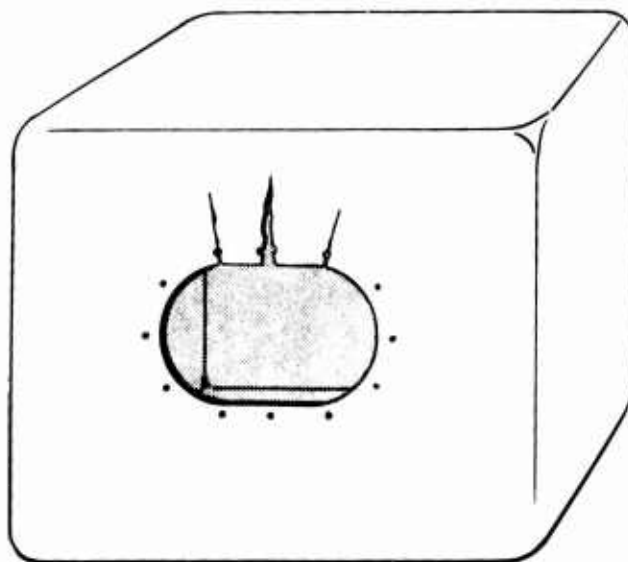

Figure 61. Tank Wall Failure as a Result of Overstressed Bearing Holes.

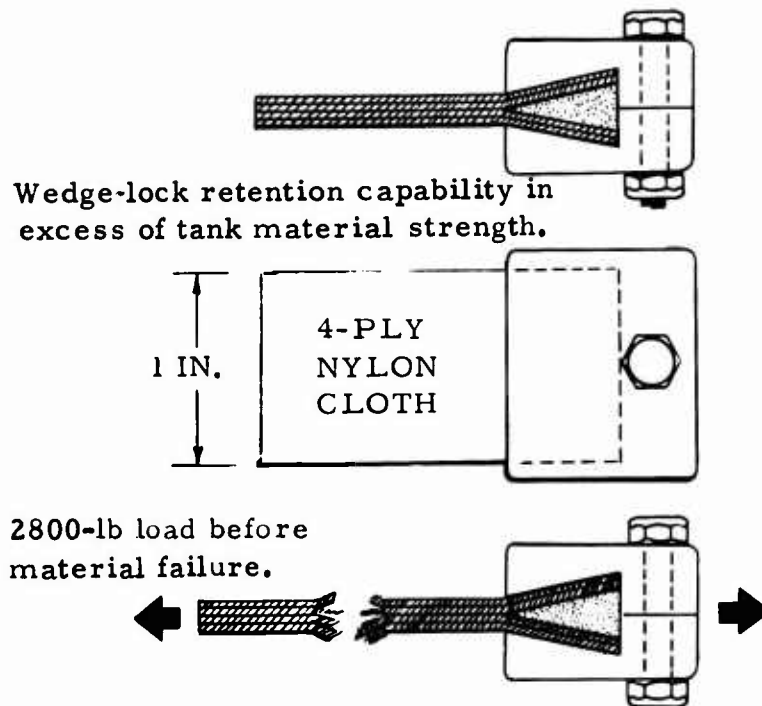

Figure 62. Wedge-Lock Fitting.

tensile test machine, and the samples were pulled at 20 inches per minute. The dynamic tests were conducted on a drop tower, subjecting the specimens to a 60 to 80G crash pulse, with a "G" rate of onset in the 6,000- to 30,000-per-second range. In all tests, the wedge-lock successfully held the tank material in the various clamping devices, causing failures to occur in the tank wall rather than at the clamp.

#### FIBER-LOCK FITTING

The fiber-lock fitting is shown in Figure 64. The basic elements of the fitting are a metal insert, elastomer impregnated fiber bundles, and a rubber flange. The evenly spaced fiber bundles distribute the load on the fitting throughout the fuel cell material, avoiding stress concentrations on any part of the fitting attachment.

Fiber-lock samples were tested statically and dynamically to determine the attachment strength of the fitting. Static tests were conducted on a Tinnius-Olsen tensile test machine at a pull rate of 20 inches per minute and on a Dillon tensile test machine at a rate of one inch per minute. The dynamic tests were conducted on a drop tower, subjecting the specimens to crash pulses up to 125G, with a "G" rate of onset in the 6,000- to 40,000-per-second range. The strength of the fiber-lock attachment was equal to the strength of the basic fuel cell material.

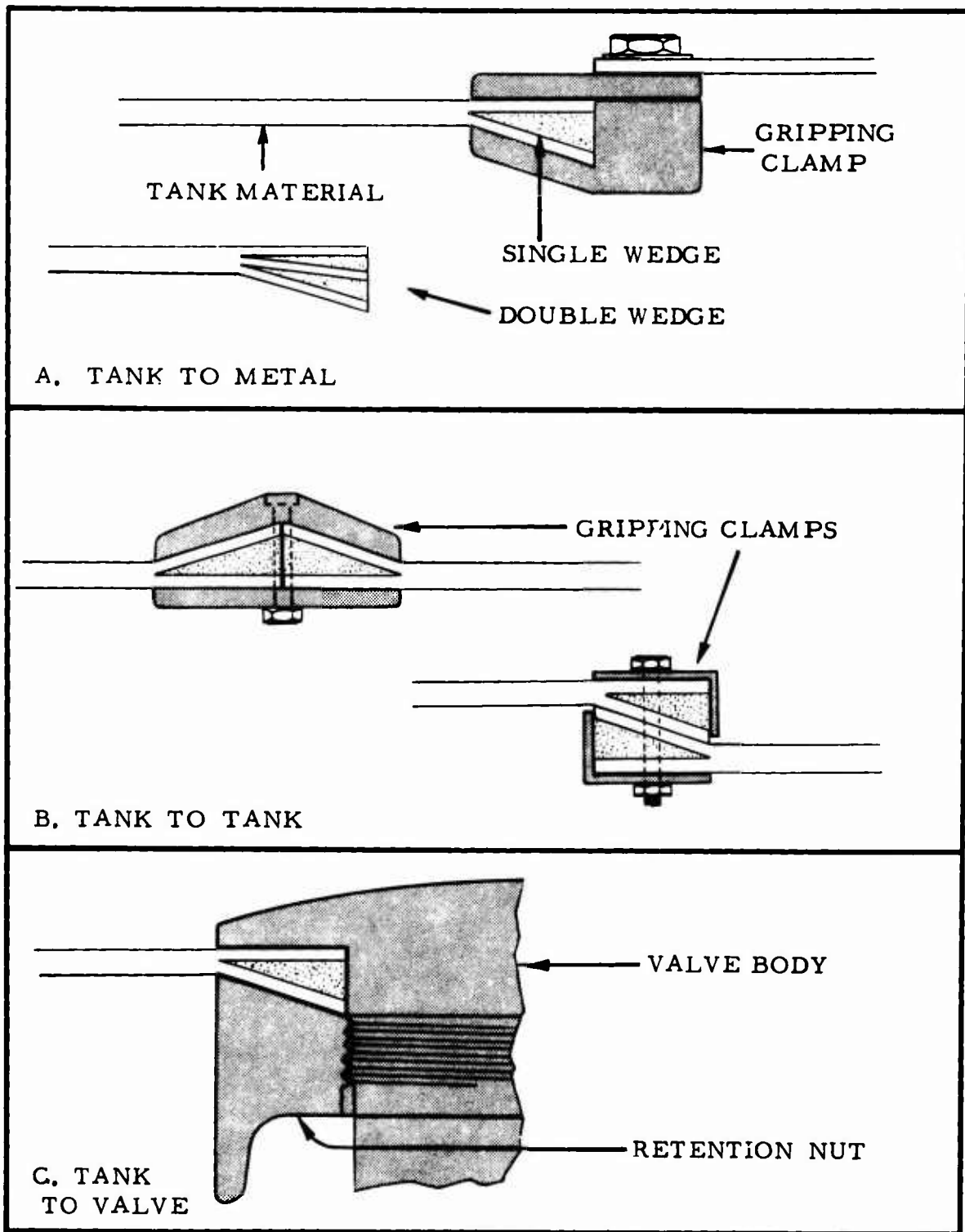

Figure 63. Wedge-Lock Load Transfer Method.

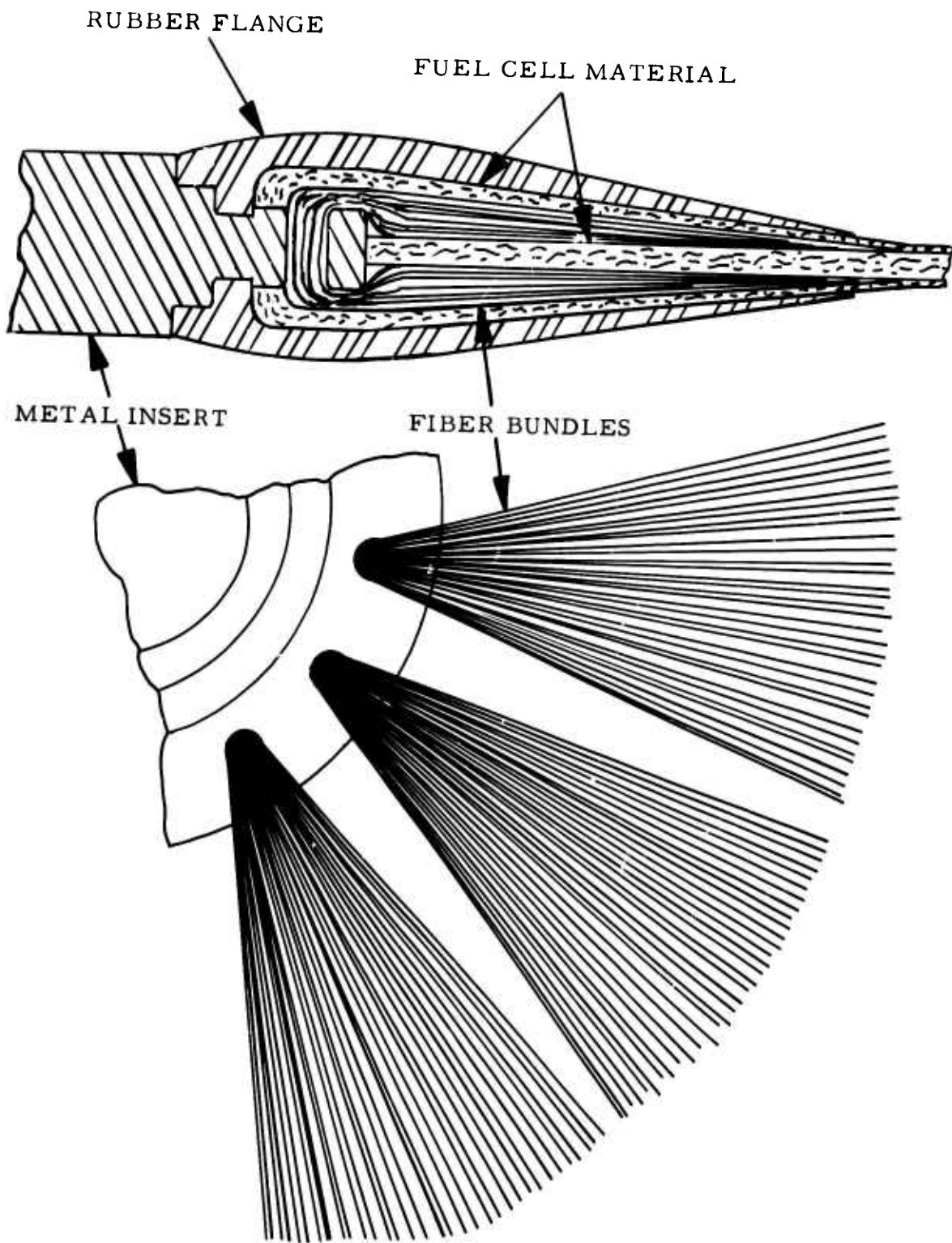

Figure 64. Fiber-Lock Fitting.

APPENDIX III  
RIGID TRIGGERING VALVE MOUNT  
(AIRFRAME MOUNTED)

OBJECTIVE

A series of tests was conducted to determine if a quick-disconnect fitting would function as a breakaway valve if it was installed in a rigid-type triggering mount.

TEST ITEM

The test item was comprised of a self-sealing quick-disconnect valve (Figure 65) installed in a special Dynamic Science-designed stainless-steel triggering valve mount (Figure 66). This test assembly, in turn, was installed in a section of simulated airframe structure. Figures 67 and 68 illustrate the triggering techniques used to apply the straight tension and lateral loads. The rigid mount converts any pulling or lateral displacement action on the protected line to a tension load at the valve. A pure tension load acts on the valve release ring to effect separation. During lateral hose movement, whether under tension or not, the camming action of the mount forces the release ring back, thereby causing the valve to release; Figure 68 illustrates this feature.

An addition in the form of a collar (Figure 65) was made to the nipple half of the quick disconnect to distribute the camming load smoothly around the periphery, rather than to force a load concentration on each corner of the nut. The modification also tended to keep the nipple centered in the mount.

TEST METHOD

The test item (valve and rigid valve mount installed in an airframe simulation) was installed aboard a drop tower cage. A 58-pound weight was attached to a hose screwed into the nipple half of the valve. The setup is illustrated in Figure 69.

The entire assembly was repeatedly dropped from the tower, subjecting the valve and the mount to crash pulses of 60 to 80G maximum with a loading rate between 6000 to 8000G per second.

Six tests were conducted: five in shear/bending and one in tension. The single tension test was conducted to serve only as a base reference,

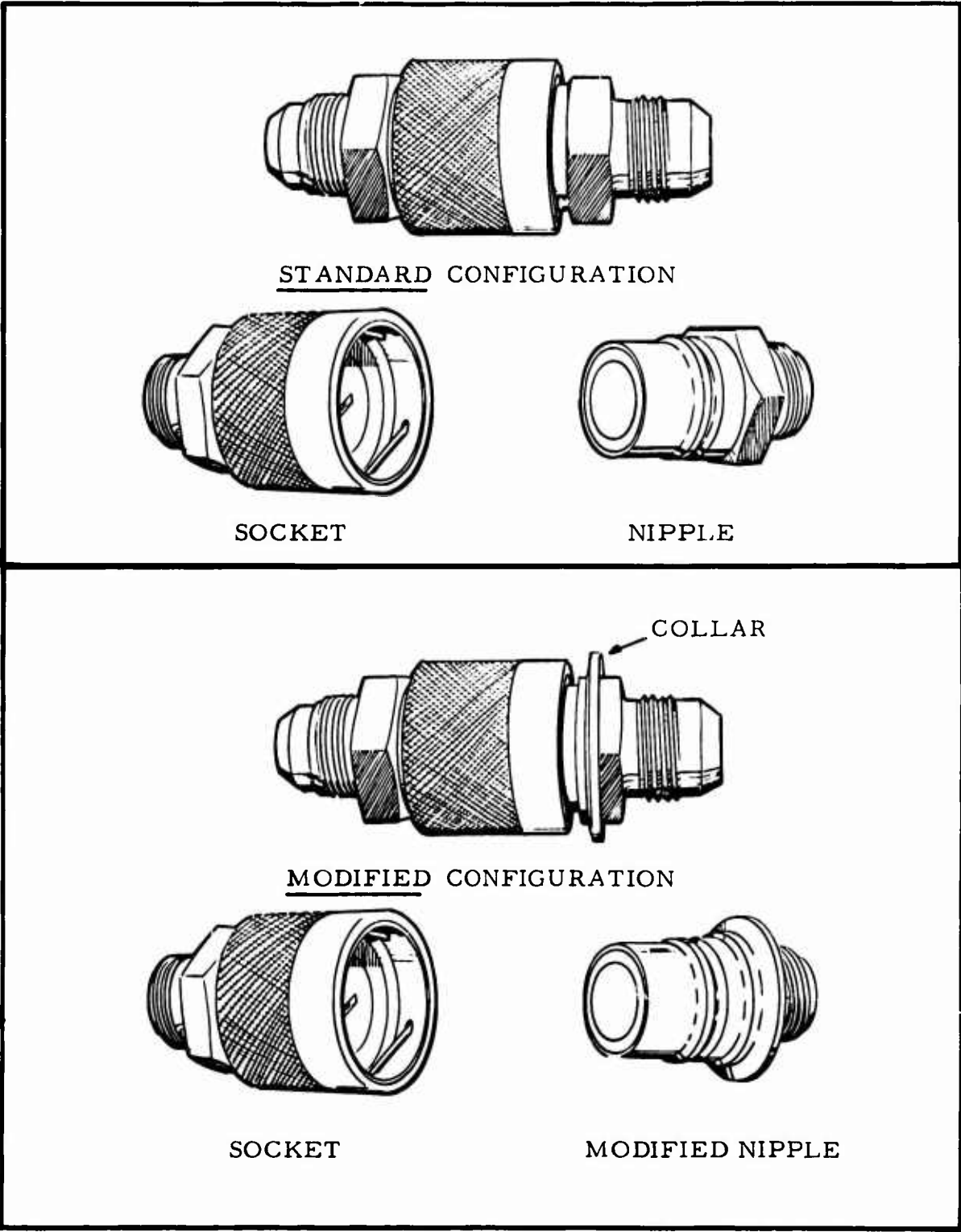

Figure 65. Modified and Standard Configuration Quick-Disconnect Valve.

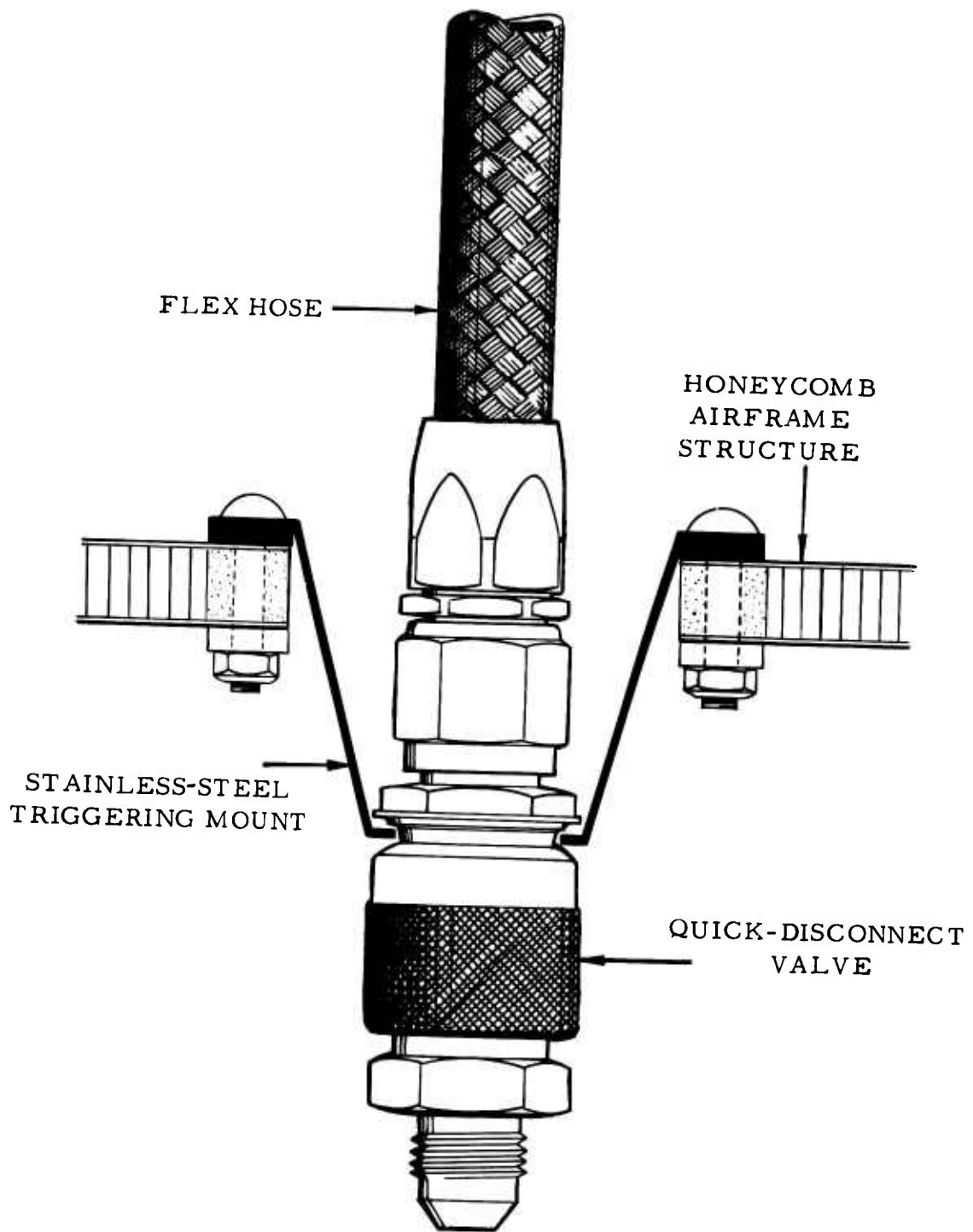

Figure 66. Rigid Triggering Valve Mount.

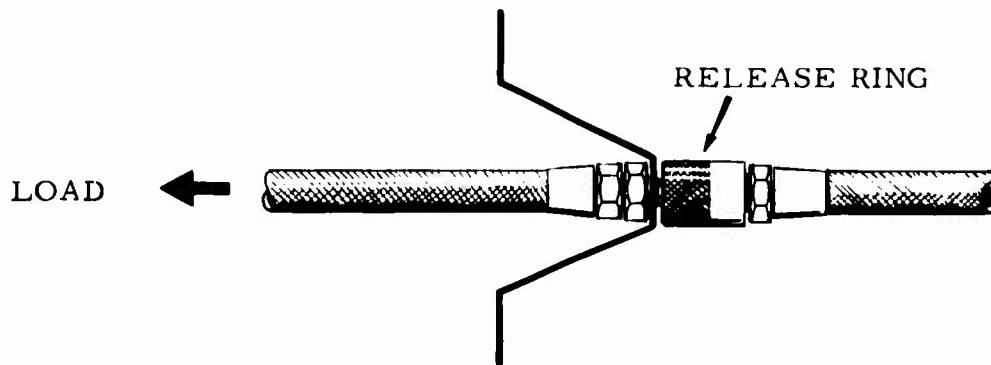

Figure 67. Rigid-Mount Triggering Technique Used During Straight Tension Load Applications.

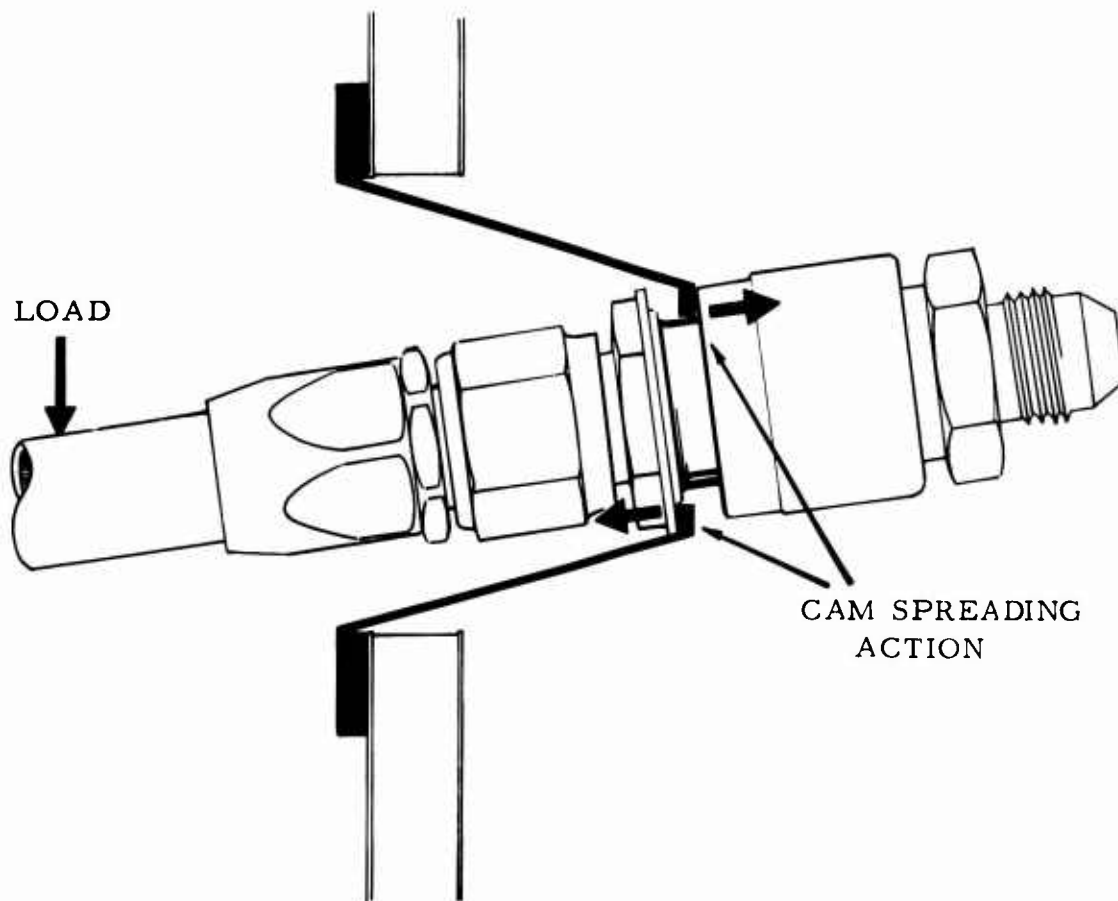

Figure 68. Rigid-Mount Triggering Technique Used During Lateral Load Displacement.

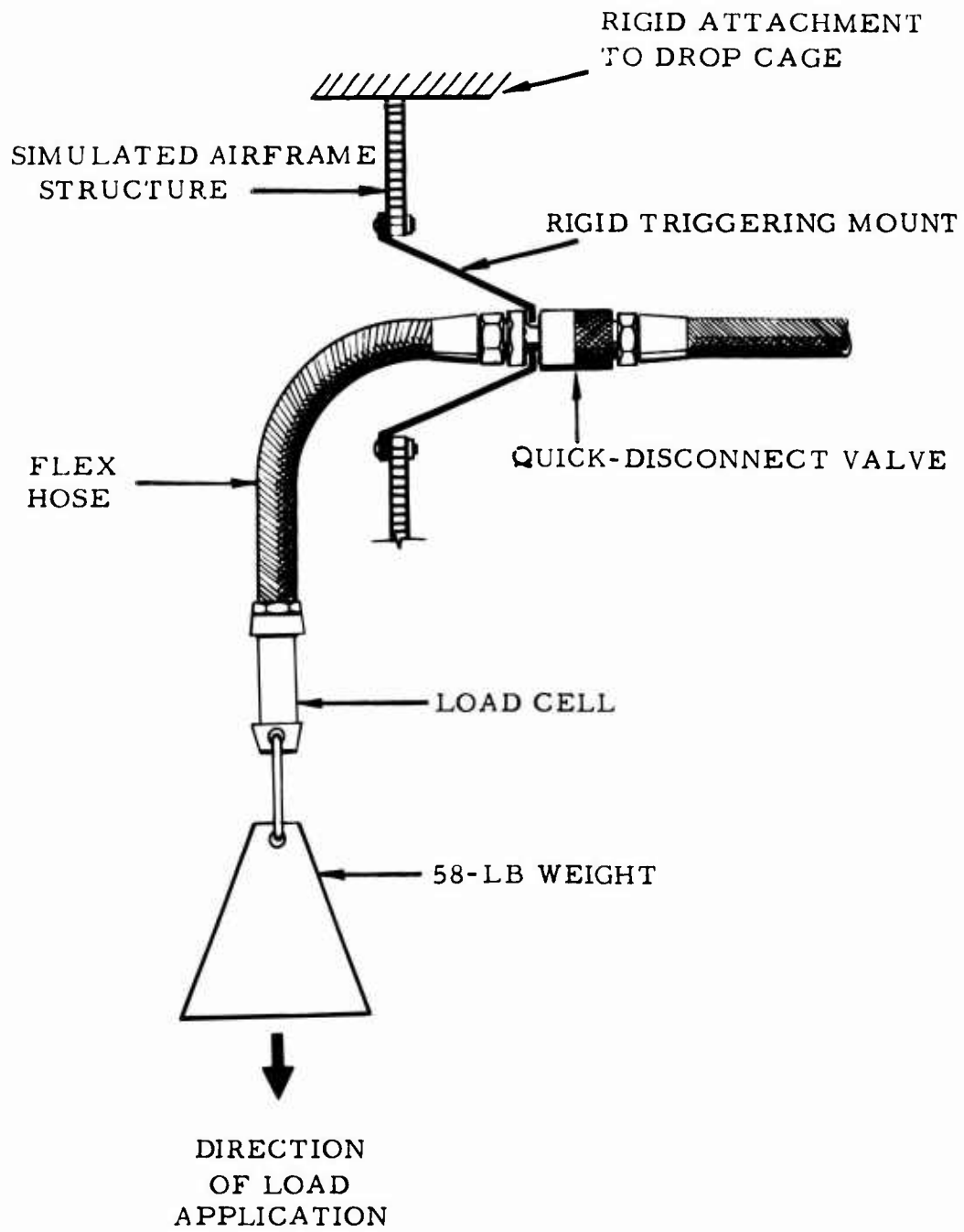

Figure 69. Rigid Triggering Mount Test Setup.

since the tension separation capability had been demonstrated in previous tests.

### INSTRUMENTATION

A 4000-pound load cell was installed between the weight and the flexible pull hose as shown in Figure 69.

A high-speed camera, mounted on the drop cage, recorded the valve separation kinematics.

### TEST RESULTS

There were no failures in any part of the system. Individual drop test results are shown in Table II.

TABLE II. RIGID TRIGGERING VALVE MOUNT TESTS				
Test/Mode	Onset Rate (G/sec)	Load (lb)	Max G	Separation
1 - Tension	5280	120	66.0	Yes
2 - Shear	8350	70	78.5	Yes
3 - Shear	8250	96	79.5	Yes
4 - Shear	5200	108	65.0	Yes
5 - Shear	5570	120	67.5	Yes
6 - Shear	4950	122	62.0	Yes

### CONCLUSION

As a result of the tests, it was concluded that a quick-disconnect-type fitting could be used as a breakaway valve, provided it is installed in a rigid mount that converts bending and shear loads to tension loads at the valve.

APPENDIX IV  
SELF-SEALING FRANGIBLE INTERCONNECTS

OBJECTIVE

The objective of this test program was to evaluate five experimental self-sealing frangible interconnects to determine which design would function best in a crash environment.

TEST ITEMS

The interconnect designs were fist-sized "one-shot" valves attached together with a frangible sleeve (Figure 70). The valves were designed to serve as a fuel flow passage between two side-by-side mounted fuel cells. Upon fuel cell displacement in the interconnect area, either between cells or between cells and airframe, the interconnects were designed to close, preventing leakage, and to break apart through the frangible sleeve if the displacement was too great.

Three of the valves were made of aluminum, one was made of aluminum and fiber glass, and one was made of synthetic material (Teflon and delrin). A brief description of each interconnect is presented in Table III.

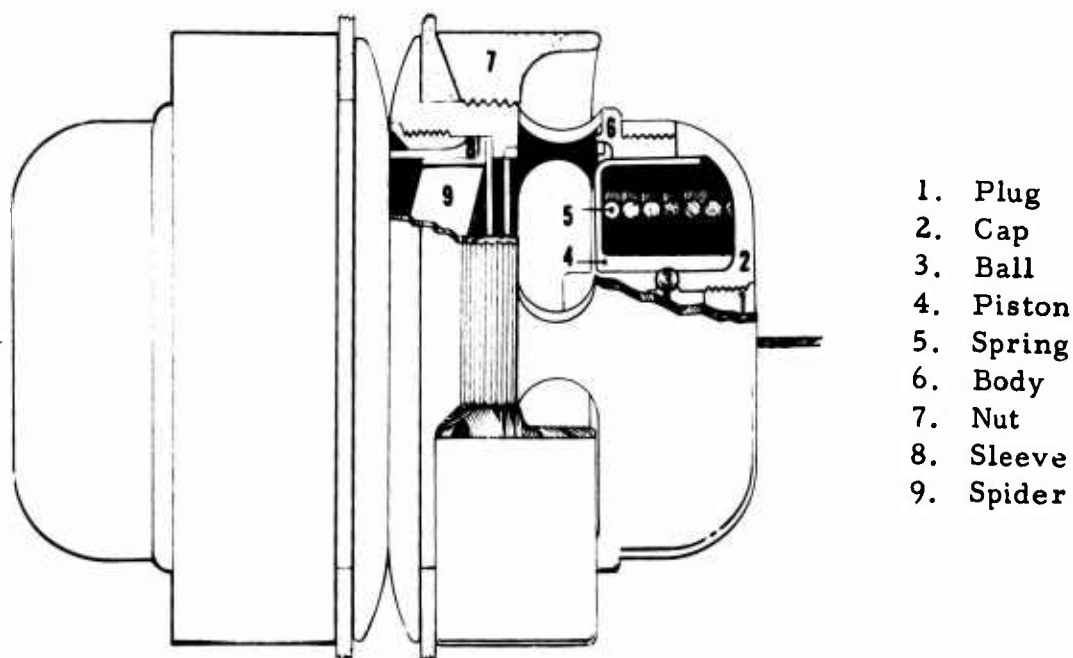

Figure 70. Frangible Interconnect, Type A Illustrated.

TABLE III. GENERAL SPECIFICATIONS - SELF-SEALING FRANGIBLE INTERCONNECTS

Specification	Interconnect				
	Type A	Type B	Type C	Type D	Type E
Weight	2.40 lb	1.30 lb	2.50 lb	2.43 lb	3.00 lb
Length	5.60 in.	4.75 in.	4.50 in.	10.00 in.	9.50 in.
Width	4.50 in.	3.50 in.	3.75 in.	3.50 in.	3.50 in.
Composition	Aluminum	Aluminum & Fiber Glass	Aluminum	Aluminum	Teflon and Delrin
Method of Triggering	Displacement and/or Cable Pull	Displacement	Displacement and/or Cable Pull	Displacement and/or Cable Pull	Displacement and/or Tube Breakage
Piston Release Technique	Cable and Ball Poppet	Rod and Dog Latch	Shear Pin	Cable and Ball Poppet	Pneumatic Bellows

## TEST METHOD

The interconnects were evaluated by two methods: by dynamic tests and by evaluation against the Dynamic Science-developed Frangible Cell-to-Cell Interconnect Crashworthiness Rating. Each technique will be discussed.

### Dynamic Tests

The interconnects were mounted in specimens of fuel tank material (Figure 71). An aluminum sheet, simulating aircraft structure, was placed around the interconnect and was sandwiched between the tank material sheets. The entire assembly was then mounted in a support frame attached to the rear of a 3/4-ton pickup truck. A schematic of the general test setup is shown in Figure 72.

Each interconnect was subjected to tests in the bending, tension, and peel modes, as shown in Figure 73.

The truck was driven at 70 miles per hour over a hook which snared a cable attached to either the tank material or the simulated aircraft structure, depending on the test desired. A rapid load was thereby applied to the interconnect, causing operation or failure.

### Crashworthiness Rating

An evaluation form was prepared to help rate the crashworthiness and operational acceptance of each design. The evaluation procedure assigned a given number of points to seven areas. Each area was further broken down into specific weighted situations. All five interconnects were subjected to the rating. The mechanics of the evaluation form are as follows:

#### FRANGIBLE CELL-TO-CELL INTERCONNECT CRASHWORTHINESS RATING

	<u>Points</u>
A. INADVERTENT ACTUATION DURING NORMAL FLIGHT OPERATION	300

Evaluate the interconnect's resistance to an inadvertent actuation which could result in fuel spillage or fuel isolation during normal flight operation (taxiing included). This form of inadvertent actuation does not include an

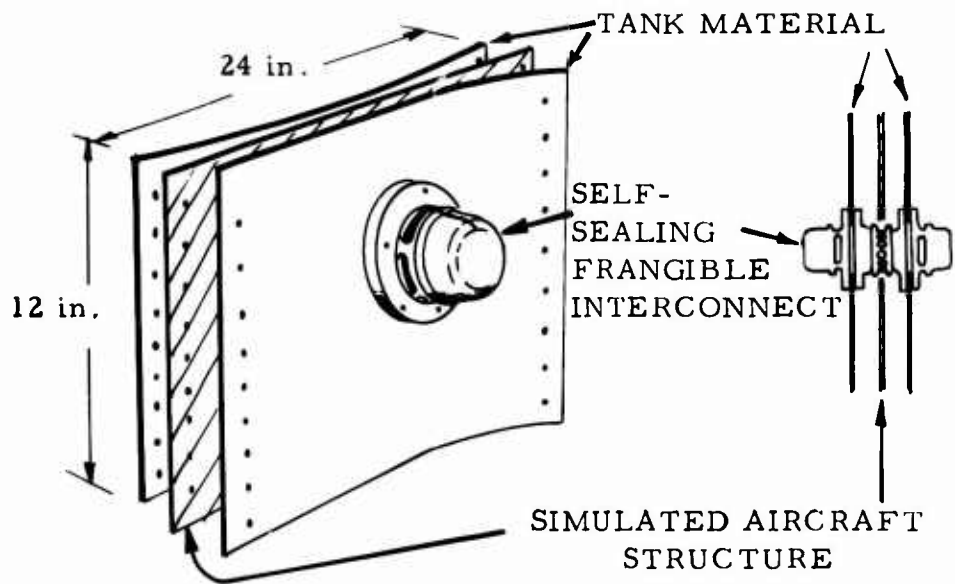

Figure 71. Interconnect Installation in Simulated Aircraft Tanks and Structure.

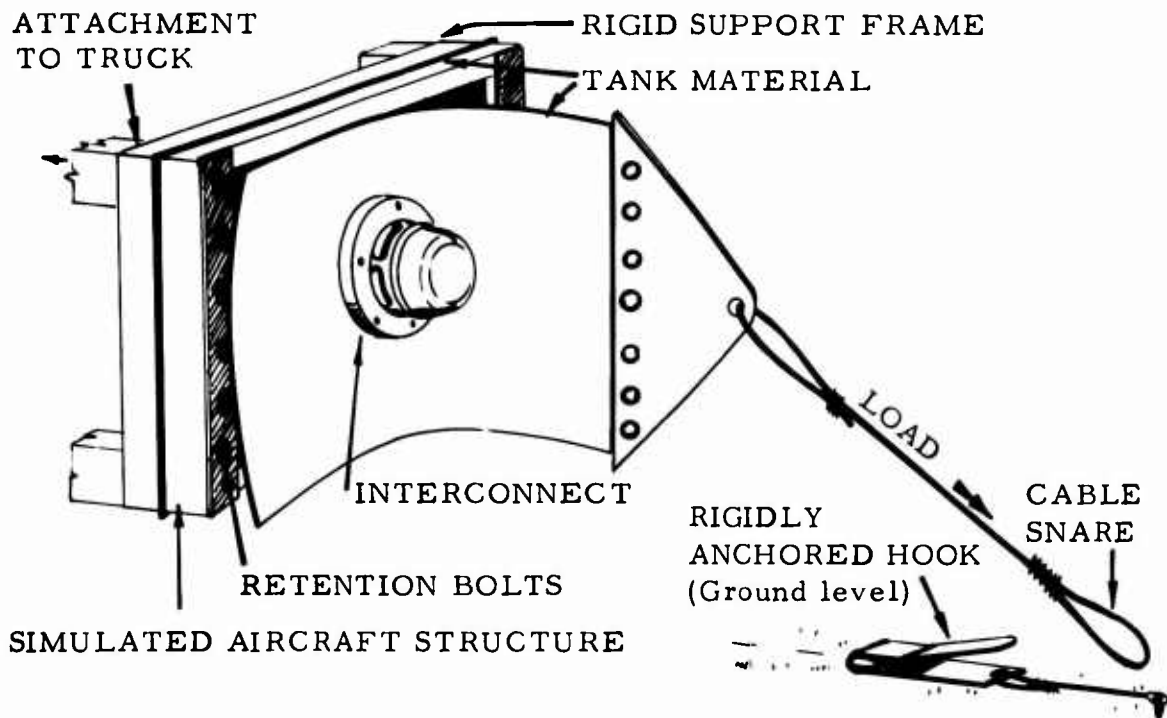

Figure 72. General Frangible Interconnect Dynamic Test Setup. (Peel test configuration is illustrated.)

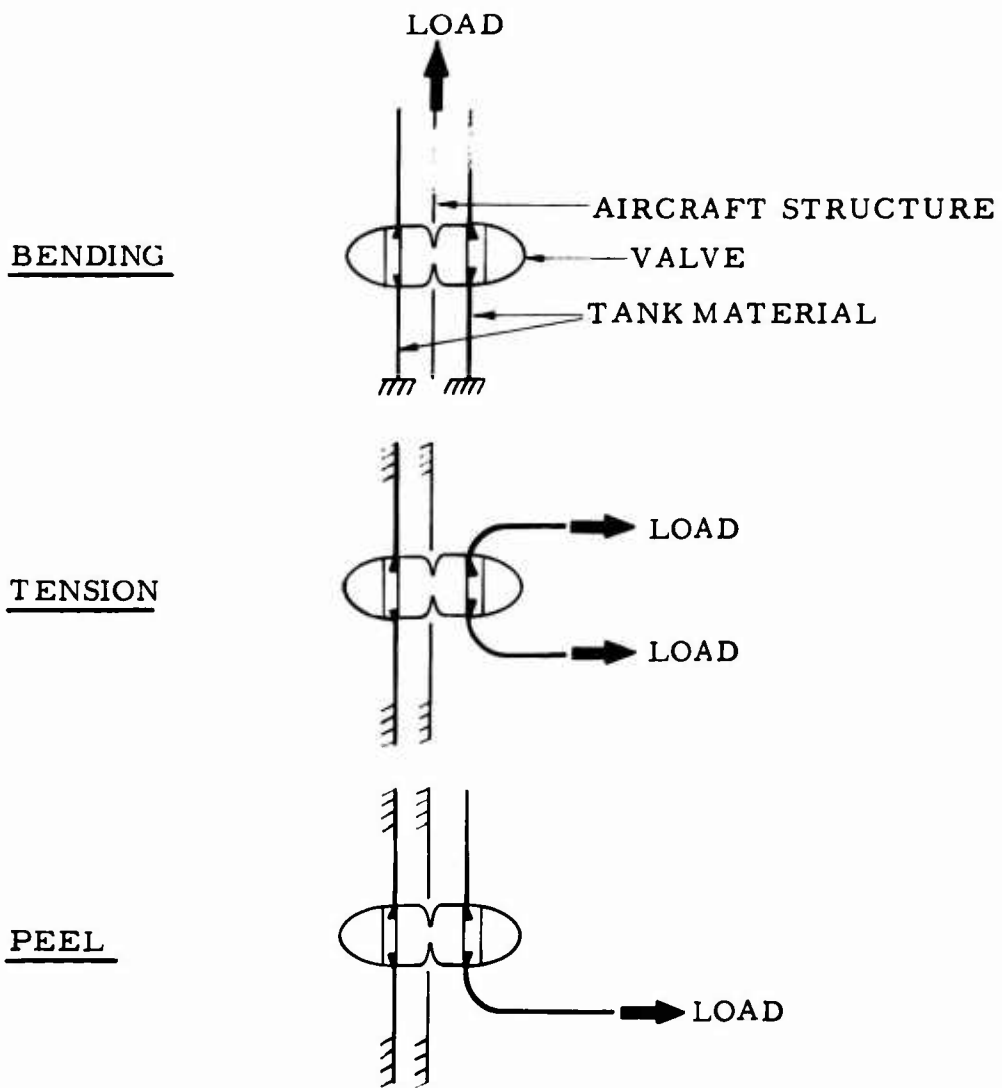

Figure 73. Direction of Load Application.

installation error or triggering which may occur during routine maintenance. These hazardous situations are evaluated under a separate heading.

The following evaluation items should be considered during environmental conditions, both physical (accelerations, temperatures, creep, etc.) and chemical (fungus, corrosion, etc.):

- |    |   |       |
|----|---|-------|
| 1. | Inadvertent triggering<br>(Most resistance - most points)   | (100) |
| 2. | Valve separation<br>Fuel isolation and/or loss implied<br>(Most resistance - most points)                 | ( 70) |
| 3. | Bellows leakage<br>Fuel loss implied<br>(Most resistance - most points)                                   | ( 50) |
| 4. | Loosening of valve components<br>Fuel isolation and/or leakage implied<br>(Most resistance - most points) | ( 50) |
| 5. | Re-cocking capability<br>(Easiest to re-cock - most points)   | ( 30) |

Points

B. VALVE TRIGGERING

200

Evaluate the probability of the valve's triggering when loads applied between the two valve assemblies are in the tension, shear, peel, and a combination of compression and shear directions. Items to be considered during this phase of the evaluation include:

- |    |  |       |
|----|--|-------|
| 1. | Valve distortion interference (crushing, buckling, bending, and similar-type valve body and/or inner components disfiguration)<br>(Least likely - most points) | ( 40) |
| 2. | Number of moving parts and sequencing parts<br>(Lowest number - most points)   | ( 40) |
| 3. | Bellows or interconnect coupling interference<br>(Least likely - most points)  | ( 30) |

4. Failure of a triggering component ( 30)  
(Least likely - most points)
5. Environmental considerations ( 30)  
(Least likely - most points)
  - a. Physical (creep, temperature, etc.)
  - b. Chemical (corrosion, fungus, etc.)
6. Other observed hazards ( 30)  
(Least noted - most points)

Points

C. VALVE CLOSING

150

Evaluate the valve closing sequence starting from the completion of effective triggering until the closing surface (piston, sliding gate, etc.) comes to a stop at the end of its travel. Items to be considered during this phase of the evaluation include:

1. Failure of the actual closing device ( 30)  
(pistons, etc.)  
(Least likely - most points)
2. Number of moving parts and sequencing events ( 30)  
(Lowest number - most points)
3. Number of possible interference methods ( 30)  
(bent components, foreign-body ingestion, bellows, interference, etc.)  
(Lowest number - most points)
4. Environmental considerations ( 30)  
(Least interference - most points)
  - a. Physical (creep, temperature, etc.)
  - b. Chemical (corrosion, fungus, etc.)

- 5. Closure speed ( 20)  
(Fastest - most points)
- 6. Other observed hazards ( 10)  
(Least - most points)

Points

D. SECONDARY SPILLAGE 150

Secondary spillage refers to fuel spillage that occurs as a result of the valve, but not through the valve itself. Items to be considered include:

- 1. Likelihood of the valve's (or a portion thereof) being pulled or torn free from the fuel tank ( 70)  
(Least likely - most points)
- 2. Likelihood of the valve's puncturing or cutting the surrounding fuel tank (valve geometry, etc.) ( 40)  
(Least likely - most points)
- 3. Other observed hazards ( 40)  
(Least observed - most points)

E. VALVE FUEL LOSS 100

Evaluate the probability of fuel loss at the interconnect during the following situations:

- 1. Premature interconnect separation ( 40)  
(Least likely - most points)
- 2. Interconnect coupling leakage without separation (cut bellows, etc.) ( 30)  
(Least likely - most points)
- 3. Interconnect separation after piston closure ( 20)  
(Least loss - most points)

- 4. Other fuel leakage possibilities ( 10)  
(Least loss - most points)

Points

F. VALVE CLOSURE SEAL

70

Evaluate the sealing capability of the valve closure method. Items to be considered are:

- 1. Inadvertent reopening ( 20)  
(Least likely - most points)
- 2. Number of primary sealing surfaces ( 10)  
(Least number - most points)
- 3. Number of redundant sealing surfaces ( 10)  
(Most number - most points)
- 4. Valve body or component distortion ( 10)  
(Least likely - most points)
- 5. Environmental considerations ( 10)  
(Least influence - most points)
- 6. Other observed hazards ( 10)  
(Least number - most points)

G. INADVERTENT ACTUATION DURING CRASH CONDITIONS

30

Evaluate the valve from the standpoint of susceptibility to inadvertent or erroneous actuation. Items to be considered are:

- 1. Installation error ( 10)  
(Least likely - most points)
- 2. Maintenance interference ( 10)  
(Most trouble free - most points)
- 3. Re-cocking capability ( 10)  
(Easiest - most points)

## TEST INSTRUMENTATION

Dynamic tests were recorded on high-speed film, and 4x5-inch black and white photographs were taken before and after each test.

## TEST RESULTS

### Dynamic Tests

The Type A, Type C, and Type D interconnects passed the dynamic tests without any failures that would cause fuel spillage. The Type B interconnect weighed the least; however, it was not rugged enough for the severe tests. The Type E interconnect was the most fragile of the five; however, this was due primarily to the fact that the interconnects were made of Teflon and delrin (see Discussion). The Type C interconnect was rugged enough to withstand the crash environment; however, it would not operate satisfactorily in the bending (Figure 73) mode. A summary of the performance of each interconnect is presented as Table IV.

### Evaluation Results

A tally of the points given each interconnect is presented in Table V.

## DISCUSSION

The points given on the rating indicated that both the Type A and the Type C interconnects were equal and that both were more acceptable than the other three. However, the dynamic tests demonstrated that the Type A interconnect would operate during all three loading environments, whereas the Type C interconnect would not do so during the bending mode. As a result of these tests, the Type A interconnect was selected for inclusion in the UH-1A crash test program.

The Type E interconnect deserves further discussion, as it was rather novel. An attempt was made to fabricate the fuel-tank-mounted component out of materials that would not spark when struck with bullets. From a fire point of view, this was an important consideration and should be explored in detail. Unfortunately, little is actually known about the dynamic behavior of synthetic materials when subjected to high G environments; consequently, the designers of this valve undertook a major problem. The valve design was "typical"; however, it is felt that a more compact design could have been used.

TABLE IV. COMPARISON OF INTERCONNECTS

Test	Type A	Type B	Type C	Type D	Type E
<b>Bending</b>					
Valve Closure	Yes	Yes	No	Yes	Yes
Interconnect Separation	Yes	Yes	No	Yes	Yes
Fuel Spillage	No	Yes	No	No	No
<b>Tension</b>					
Valve Closure	Yes	Yes	Yes	Yes	Yes/No
Interconnect Separation	Yes	Yes	Yes	Yes	No
Fuel Spillage	No	Yes	No	No	Yes
<b>Peel</b>					
Valve Closure	Yes	Yes	Yes	Yes	Yes
Interconnect Separation	Yes	Yes	Yes	Yes	Yes
Fuel Spillage	No	No	No	No	Yes

TABLE V. CELL-TO-CELL INTERCONNECT COMPARISON RATINGS

Feature	Available Points	Type A	Type B	Type C	Type D	Type E
Resistance to Inadvertent Actuation (In Flight)	300					
1. Inadvertent triggering	100	60	90	100	60	80
2. Valve separation	70	60	60	50	60	50
3. Bellows leakage	50	40	40	30	40	30
4. Loosening of components	50	40	20	50	20	40
5. Re-cocking capability	30	0	0	0	20	0
Valve Triggering	200					
1. Valve distortion interference	40	40	20	40	20	30
2. No. moving parts and events	40	30	20	40	20	30
3. Bellows interference	30	30	30	30	30	30
4. Component failure	30	20	20	0	10	20
5. Environmental considerations	30	20	20	10	20	10
6. Other observed hazards	30	30	30	30	30	30
Valve Closing	150					
1. Closing device failure	30	20	30	30	20	30
2. No. moving parts and events	30	20	20	30	10	20
3. No. interference methods	30	10	10	20	10	20
4. Environmental considerations	30	20	20	30	20	20
5. Closure speed	20	20	20	20	20	10
6. Other observed hazards	10	10	10	10	10	10

TABLE V. Continued

Feature	Available					
	Points	Type A	Type B	Type C	Type D	Type E
Secondary Spillage	150					
1. Valve pulled from tank	70	70	20	60	60	20
2. Valve cutting tank	40	40	40	40	20	40
3. Other observed hazards	40	40	30	40	30	30
Valve Fuel Loss	100					
1. Premature separation	40	30	30	30	30	40
2. Leakage without separation	30	30	30	30	20	30
3. Separation after piston closure	20	20	10	20	10	10
4. Other leakages	10	10	10	10	10	10
Valve Closure Seal	70					
1. Inadvertent reopening	20	20	0	0	0	10
2. No. primary sealing surfaces	10	10	10	0	0	10
3. No. redundant sealing surfaces	10	10	10	0	0	0
4. Component distortion	10	10	0	10	0	0
5. Environmental considerations	10	10	10	10	10	0
6. Other observed hazards	10	10	10	10	10	10
Inadvertent Actuation During Crash	30					
1. Installation error	10	10	10	10	0	0
2. Maintenance interference	10	10	10	10	0	0
3. Re-cocking capability	10	0	0	0	10	0
TOTALS	1000	800	690	800	630	070

The method of valve triggering was new to this application; however, it was not new to Type E designs. The concept involved the use of two 1/16-inch-diameter, hollow, pressurized, stainless-steel tubes which were laced between the interconnect valves and the surrounding structure. The pressurized system holds two bellows assemblies (one inside the other) extended, causing the valve to stay open. Rupture of both lines allows pressure bleed-off, thereby closing the valves. The use of two independent systems provides a redundancy which is preferred. The pressurized system also lends itself to cockpit monitoring of the valve positions and could also be used to cycle the valves.

It is felt that the two concepts demonstrated in the Type E interconnect are sound and are worth further investigation.

APPENDIX V  
FRANGIBLE MATERIAL TESTS

GENERAL

Four frangible material test series were conducted during the course of this research effort. The purpose of the material tests was to gather data which could be used for the design of various frangible components. The subjects of the series were:

First Series - Basic Material Tests

Second Series - Frangible Filler Neck Mounting Ring Tests

Third Series - Frangible Boost Pump Mounting Ring Tests

Fourth Series - Frangible Baffle Tests

FIRST SERIES - BASIC MATERIAL TESTS

Objective

The objective of this test series was to determine the tension and bending loads required to fail frangible material specimens.

Test Items

The test items were rectangular specimens (Figure 74) made from 6-ounce-per-yard, square weave, fiber glass cloth impregnated with rigid, unsaturated, orthophthalic polyester resin. They were fabricated in 2-ply, 4-ply, 5-ply, and 6-ply configurations; the thicknesses were .023, .035, .042, and .048 inch, respectively.

Test Method

The tension and bending tests were conducted on a Dillon universal tester, with the loads being applied at a 1-inch-per-minute rate. The test setup for the tension test is presented in Figure 75; the setup for the bending test, in Figure 76.

Twenty-four tests were made, twelve in each failure mode. The test specimens were loaded until a clear break in the material occurred.

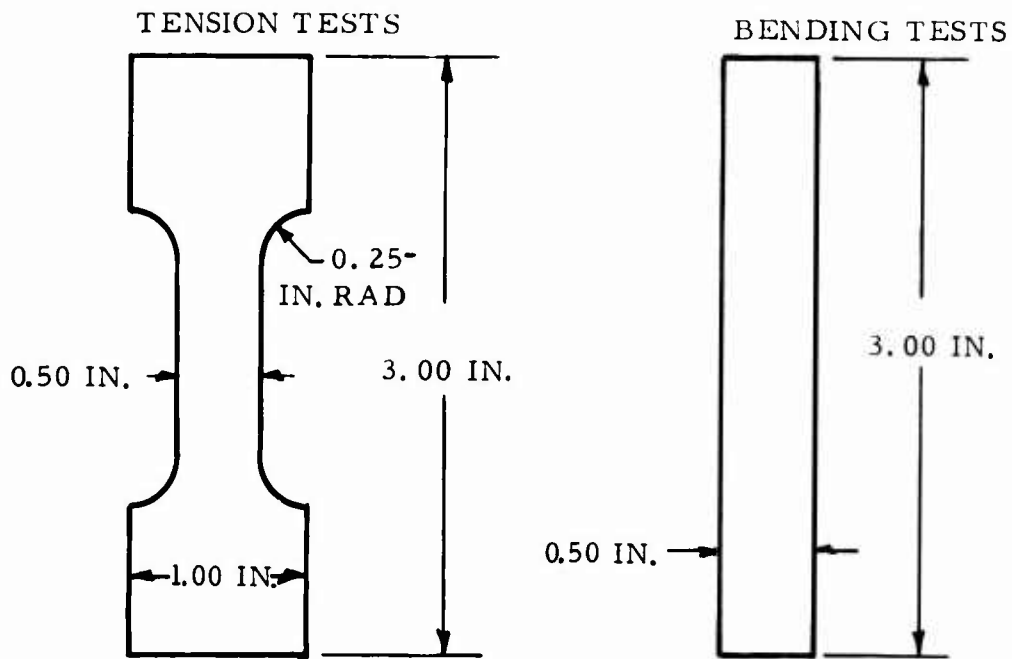

Figure 74. Frangible Material Test Specimen.

#### Instrumentation

A 1000-pound load cell was installed in the test setup between the rigid tiedown and the test specimen, as shown in Figures 75 and 76. The loads were read directly as they were applied, until specimen failure.

A load link measured the loads applied on the Dillon tester, and direct readings were read on a strain indicator. Statham A-5-100G accelerometers and load links measured the accelerations and forces resulting from the drop tests.

#### Test Results

Results of the static and dynamic tests are presented in Table VI.

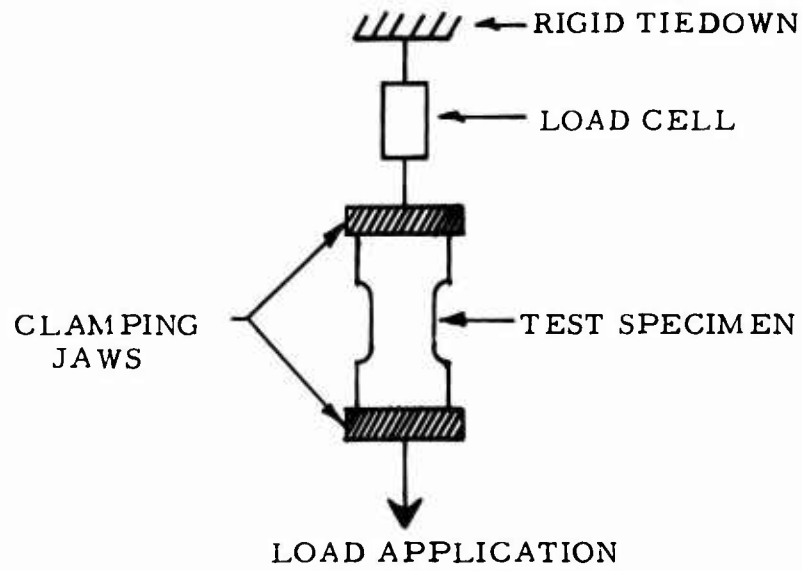

Figure 75. Tension Load.

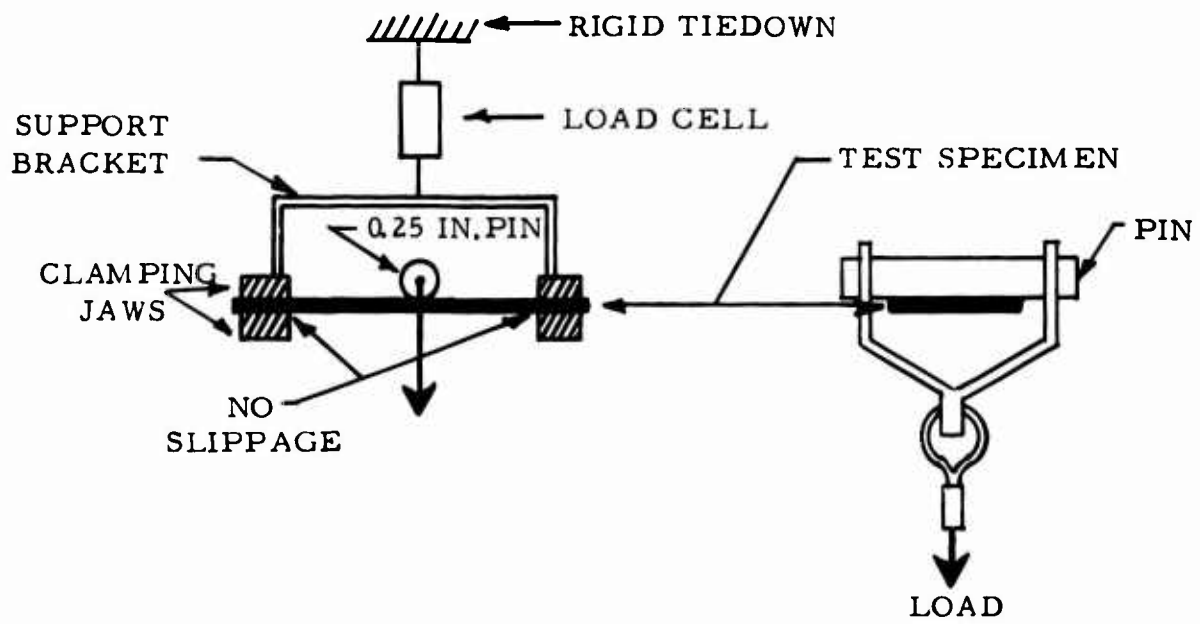

Figure 76. Bending Test.

TABLE VI. FRANGIBLE MATERIAL TESTS\*

Tension Tests		Bending Tests	
Specimen	Breaking Point** (lb/linear in.)	Specimen	Breaking Point** (lb/linear in.)
2-ply	235	2-ply	68
4-ply	741	4-ply	112
5-ply	811	5-ply	170
6-ply	866	6-ply	238

\*Material composition: 6-ounce-per-yard, square weave, fiber glass cloth impregnated with rigid, unsaturated, orthophthalic polyester resin.  
 \*\*Averages for 3 tests each.

## SECOND SERIES - FRANGIBLE FILLER NECK MOUNTING RING TESTS

### Objective

The objective of this test series was to determine the tension and shear loads required to fail frangible rings designed as couplings between the filler cap access area and the UH-1A helicopter fuselage skin.

### Test Items

The items to be tested were frangible rings (Figure 77) made of fiber glass matt fill, sandwiched between four plies of 6-ounce-per-yard, square weave, fiber glass cloth. The 0.120-inch-thick laminate was bonded together with rigid, unsaturated, orthophthalic polyester resin.

### Test Method

The frangible rings were tested statically and dynamically in both the shear and the tension mode (Figure 78). The static tests were performed on a Dillon universal tester with the loads applied at the rate of 1 inch per minute. The dynamic tests were conducted on the drop tower. The specimens were subjected to 60 to 80G crash pulses which had G rates of onset in the 5000- to 8000-per-second range. Load cells recorded the load at failure, and a high-speed movie camera recorded the failure kinematics.

### Instrumentation

A load link measured the loads applied on the Dillon tester, and direct readings were read on a strain indicator. Load links and Statham A-5-100G accelerometers measured the drop tower cage forces and accelerations.

### Test Results

The results of the static and dynamic tests are presented in Table VII.

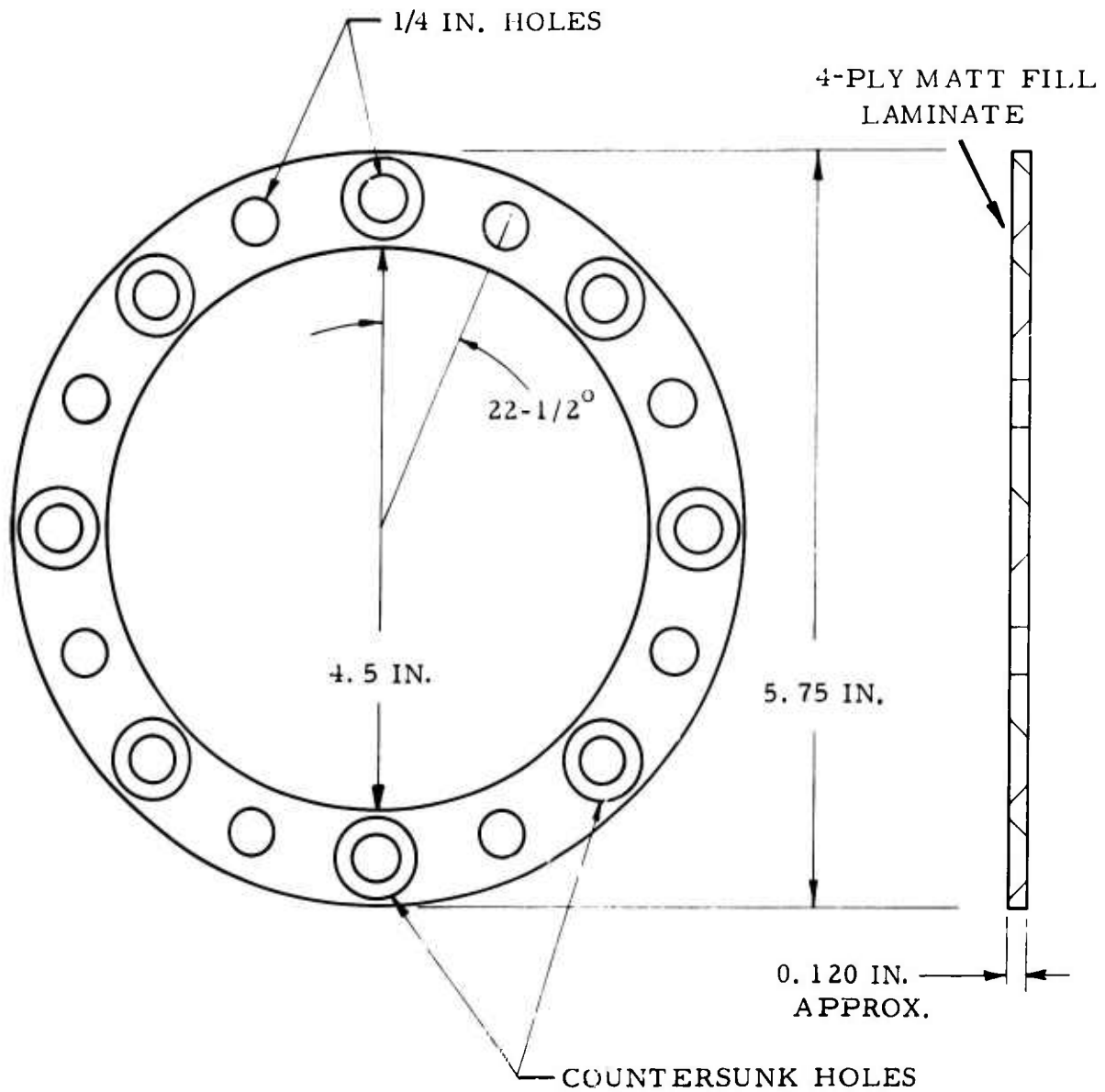

Figure 77. Frangible Ring.

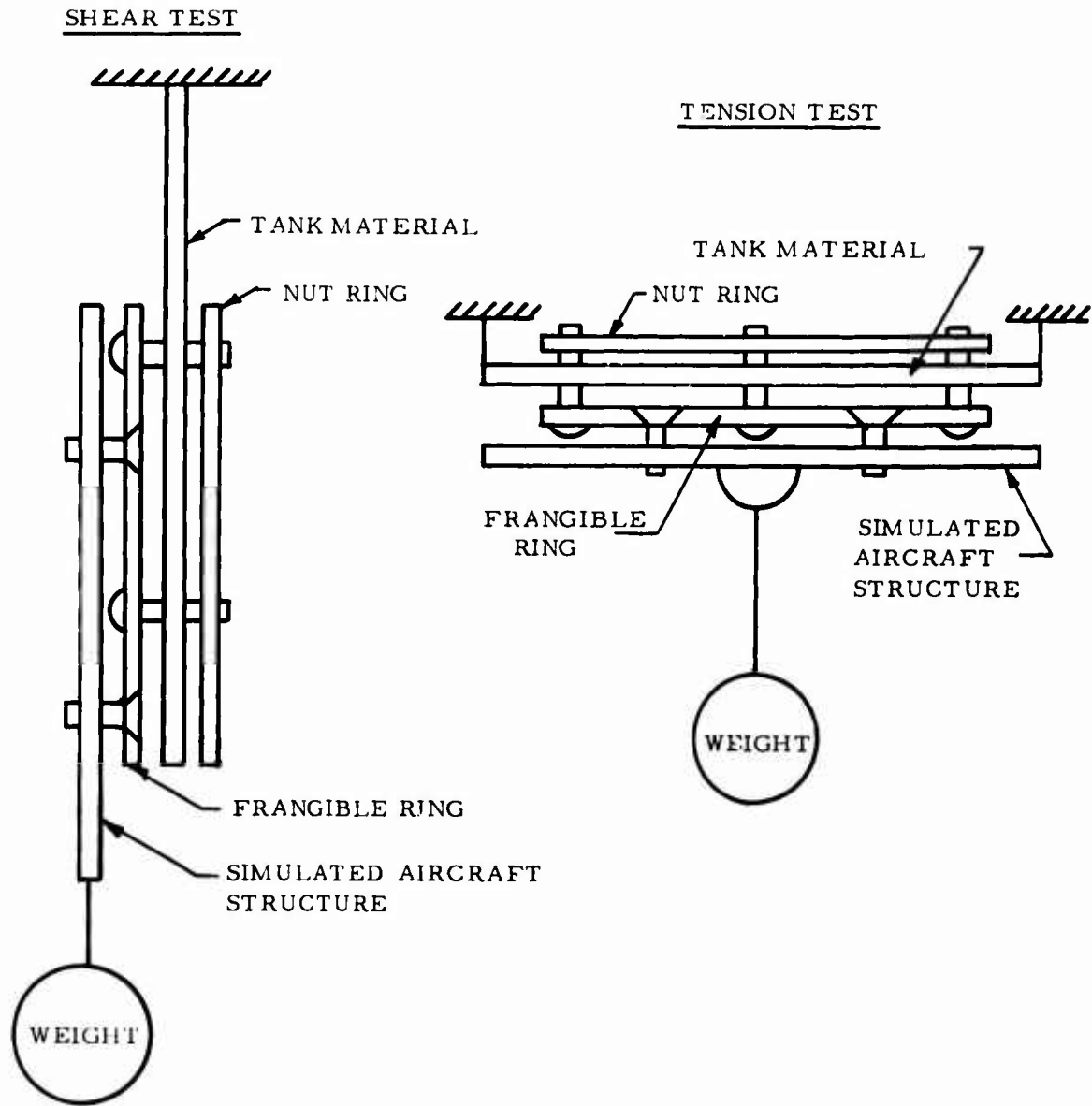

Figure 78. Frangible Ring Load Application Diagram.

TABLE VII. FRANGIBLE FILLER NECK MOUNTING RING TESTS\*

Static		Dynamic	
Test No.	Load at Failure (lb)	Test No.	Load at Failure (lb)
	<u>Shear</u>		<u>Shear</u>
1	3900	7	4375
2	3758	8	4740
3	4280	9	4850
	<u>Tension</u>		<u>Tension</u>
4	1720	10	1750
5	1596	11	2020
6	1705	12	1840

\*Ring material composition: 6-ounce-per-yard, square weave, fiber glass cloth impregnated with rigid, unsaturated, orthophthalic polyester resin.

## THIRD SERIES - FRANGIBLE BOOST PUMP MOUNTING RING TESTS

### Objective

The objective of this test series was to determine the tension and shear loads required to fail frangible rings designed as couplings between the UH-1A fuel boost pump and helicopter structure.

### Test Items

Four items were tested: two rings made of frangible materials and two sections of UH-1A helicopter fuselage structure. One ring was made of fiber glass cloth and polyester resin and the other was a linen-based phenolic. The structural test items were fiber glass-covered aluminum honeycomb panels used as attaching structure for the fuel tank filler neck assembly and the fuel boost pump in the UH-1A helicopter.

### Test Method

The frangible rings and structure were tested statically in both the shear and the tension mode. Figures 79 and 80 schematically illustrate the methods by which the load was applied. The rings were installed on a Dillon universal tester, and loads were applied at a 1-inch-per-minute rate.

### Instrumentation

A load cell measured the forces applied on the Dillon tester, and the data were read on a strain indicator.

### Test Results

Results of the static tests are shown in Table VIII.

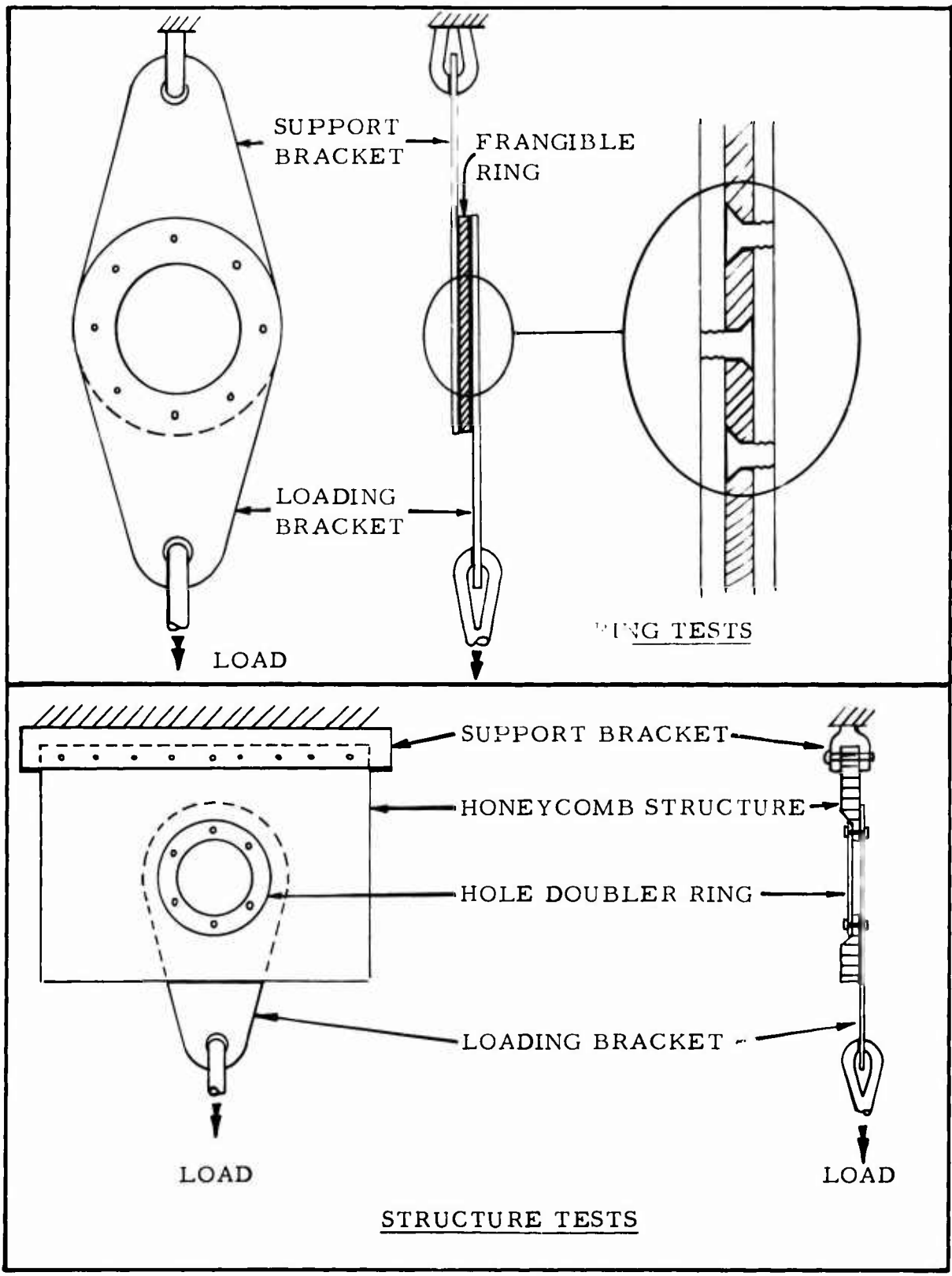

Figure 79. Shear Test.

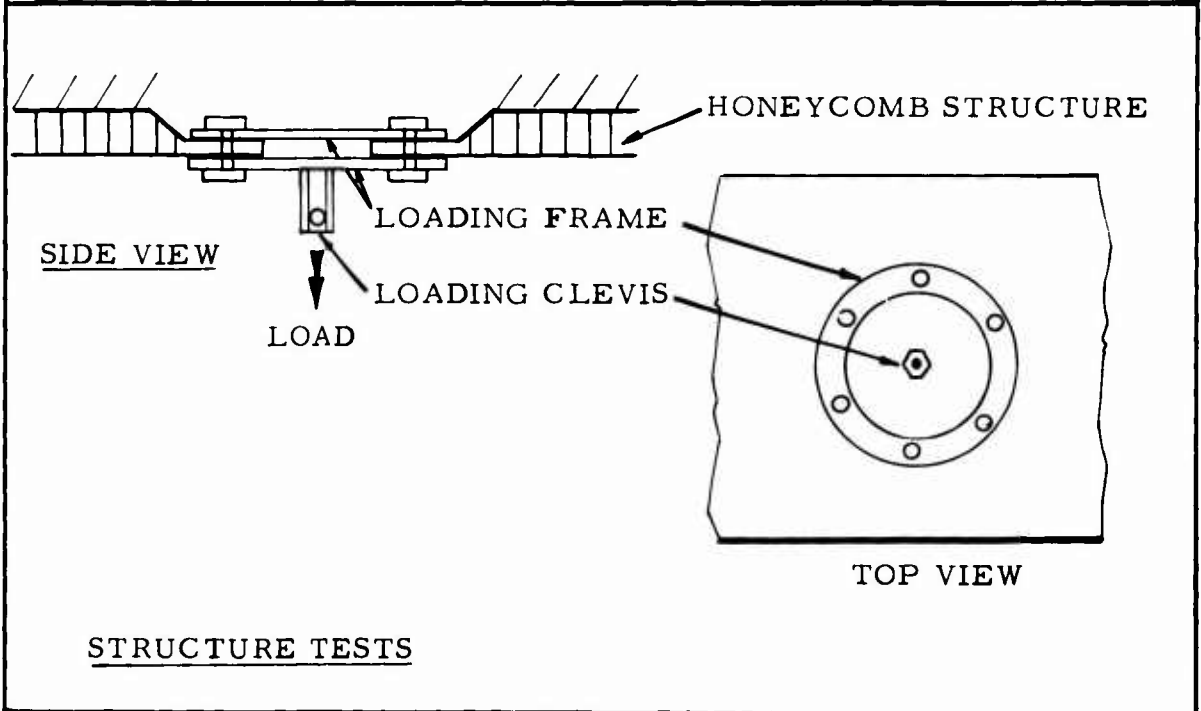
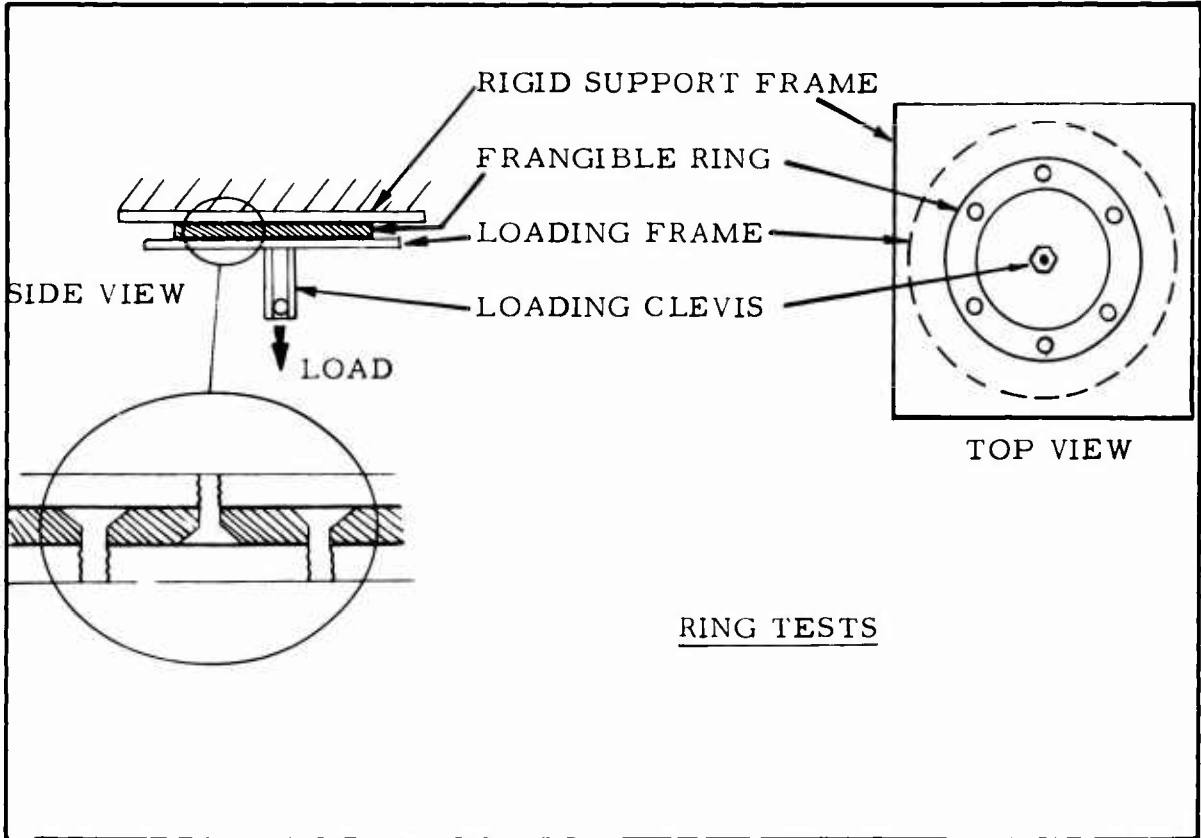
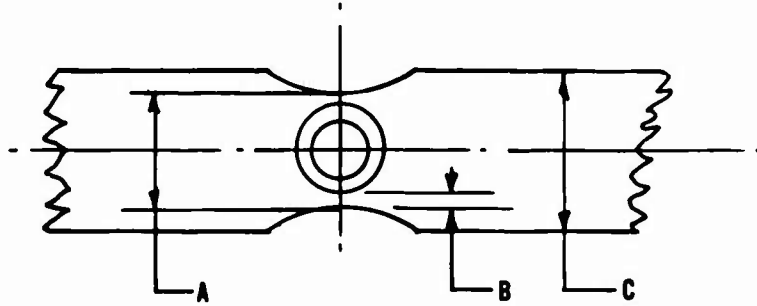

Figure 80. Tension Tests.

TABLE VIII. FRANGIBLE RING STATIC TESTS



DIMENSION REFERENCE

Test No.	Material	Thick- ness (in.)	Dimen- sions (in.)	Load (lb)	
				Shear	Tension
1	4-Ply Fiber Glass/Polyester Resin Laminate	.034	A .6250	3300*	-
			B .1406		
			C .7500		
2	4-Ply Fiber Glass/Polyester Resin Laminate	.034	A .5625	5040	-
			B .1406		
			C .7500		
3	4-Ply Fiber Glass/Polyester Resin Laminate	.034	A .5625	-	846
			B .1406		
			C .7500		
4	4-Ply Fiber Glass/Polyester Resin Laminate	.034	A .5625	-	820
			B .1406		
			C .7500		
5	5-Ply Fiber Glass/Polyester Resin Laminate	.041	A .5625	5880	-
			B .1406		
			C .7500		
6	5-Ply Fiber Glass/Polyester Resin Laminate	.041	A .5625	6422	-
			B .1406		
			C .7500		

\*Material Broke

TABLE VIII, Continued						
Test No.	Material	Thick-ness (in.)	Dimen-sions (in.)	Load (lb)		
				Shear	Tension	
7	5-Ply Fiber Glass/Polyester Resin Laminate	.041	A .5625 B .1406 C .7500	-	929	
8	5 Ply Fiber Glass/Polyester Resin Laminate	.041	A .5625 B .1406 C .7500	-	905	
9	6-Ply Fiber Glass/Polyester Resin Laminate	.045	A .5625 B .1406 C .7500	-	1026	
10	6-Ply Fiber Glass/Polyester Resin Laminate	.045	A .5625 B .140 C .7500	-	950	
11	6-Ply Fiber Glass/Polyester Resin Laminate	.045	A .5625 B .1406 C .7500	6535*	-	
12	Fiber Glass/Polyester Resin Laminate	.125	A .5625 B .0625 C .7500	4868	-	
13	Fiber Glass/Polyester Resin Laminate	.125	A .5625 B .0625 C .5625	5200	-	
14	Fiber Glass/Polyester Resin Laminate	.125	A .5625 B .0312 C .5625	4137	-	
15	Linen-Based Phenolic Insulating Board	.125	A .7500 B .1250 C .7500	4114	-	
16	Linen-Based Phenolic Insulating Board	.125	A .7500 B .1250 C .7500	-	1000	
*Material Broke						

TABLE VIII. Continued

Test No.	Material	Thick- ness (in.)	Dimen- sions (in.)	Load (lb)	
				Shear	Tension
17	Linen-Based Phenolic Insulating Board	.125	A .7500 B .1250 C .7500	-	1119
18	Linen-Based Phenolic Insulating Board	.125	A .7500 B .1250 C .7500	5120	-
19	Section from aircraft fuselage**			-	1070
20	Section from aircraft fuselage***			3523	-
21	Fiber Glass/Polyester Resin Laminate	.125	A .5625 B .0312 C .5625	-	828
22	Fiber Glass/Polyester Resin Laminate	.125	A .5625 B .0625 C .7500	-	961

\*\*Complete honeycomb panel containing the boost pump opening was removed from UH-1A for this tension test.

\*\*\*Complete honeycomb panel containing the filler opening was removed from UH-1A for this shear test.

## FOURTH SERIES - FRANGIBLE BAFFLE TESTS

### Objective

The objective of this test series was to determine the load required to pull two different-size bulkhead-type fittings through a frangible baffle. The fittings were a straight union and an elbow.

### Test Items

The items tested were 0.042-inch-thick, 8-inch-square panels made of five plies of 6-ounce-per-yard, square weave, fiber glass cloth bonded together with rigid, unsaturated, orthophthalic polyester resin.

### Test Method

Fittings were placed, one per fiber glass panel, in a frame mounted at the rear of a truck, as shown in Figure 81. The truck was driven at 30 miles per hour or 70 miles per hour, depending upon the test, over a cable snare device. As the truck passed over the cable, the snaring device coupled with the linkage attached to the hose that was attached to the fitting, thereby imposing rapid loading on the fitting.

Thirty-two tests were conducted. The method of load application is presented in Figures 82, 83, 84, and 85.

### Instrumentation

A high-speed camera recorded the kinematics, and a load cell recorded the force required to separate the fittings and baffles.

### Test Results

Average results of the 32 tests conducted in this series are presented in Table IX.

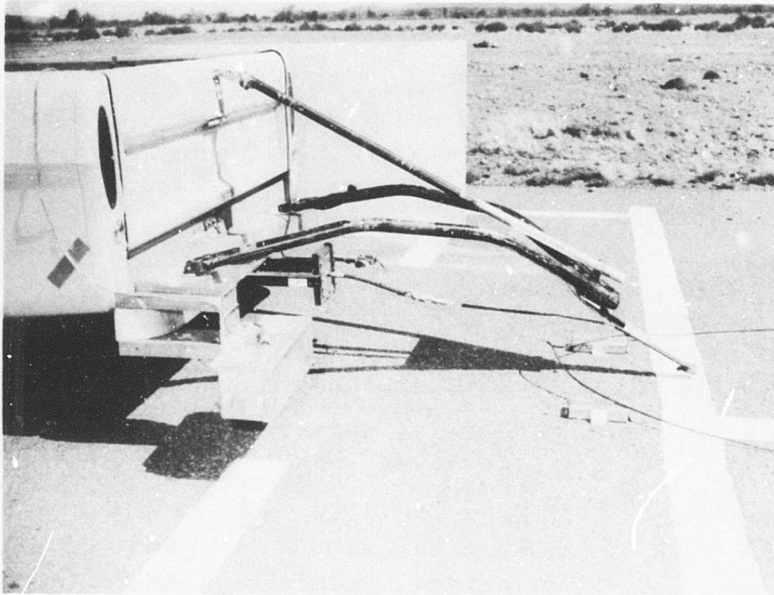

Figure 81. General Test Setup Showing Truck, Frangible Material, Fitting, Cable, and Snaring Device.

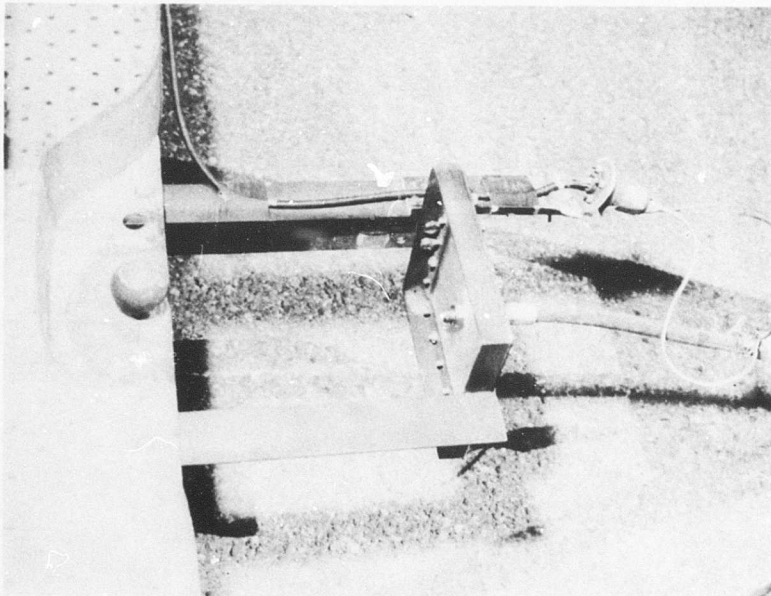

Figure 82. Straight Union Fitting - Pure Tension Load Application.

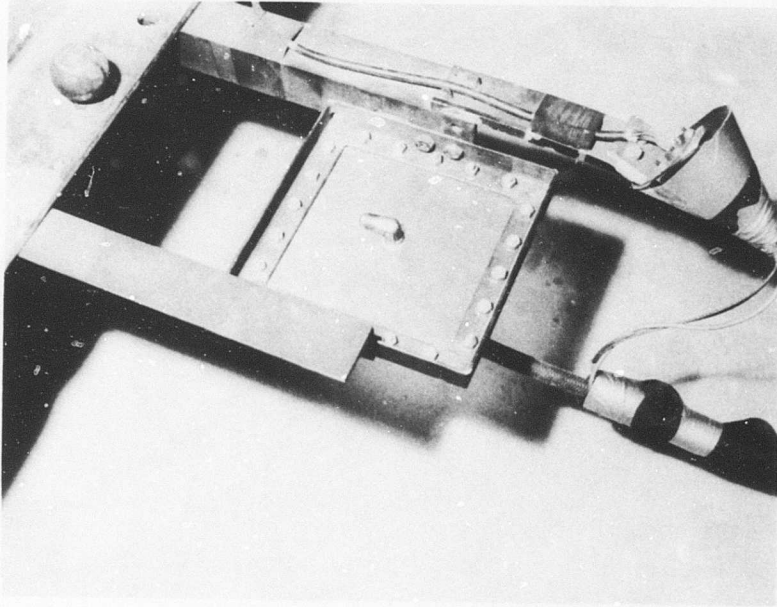

Figure 83. Elbow Fitting - Bending Load Application.

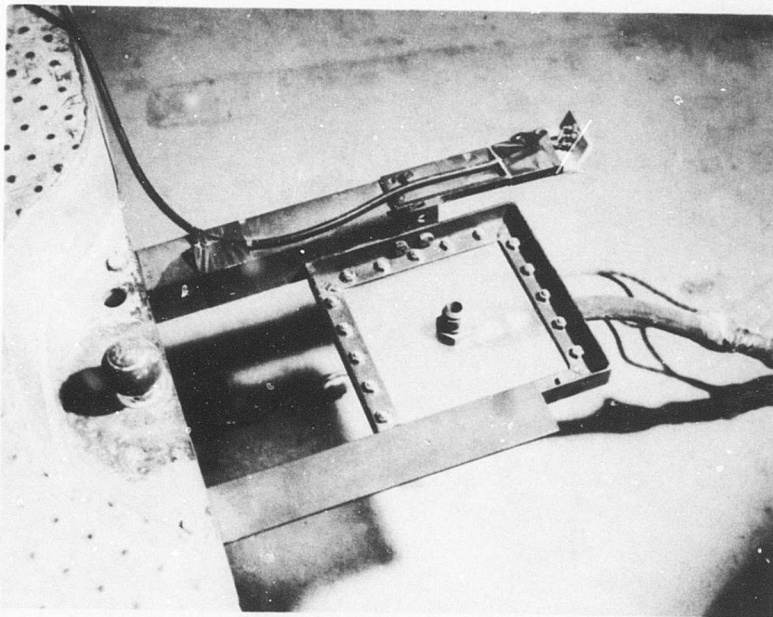

Figure 84. Elbow Fitting - Shearing Load Application.

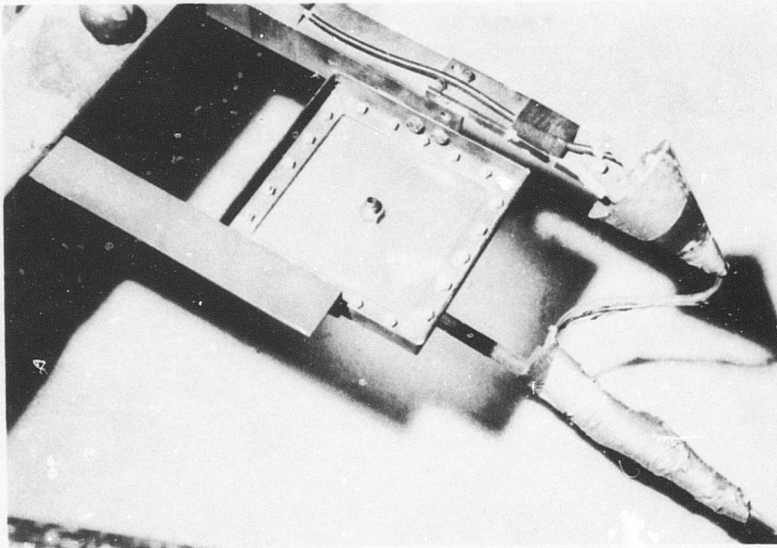

Figure 85. Straight Union Fitting - Bending Load Application.

TABLE IX. FRANGIBLE BAFFLE TEST RESULTS

Test Setup (in.)	Static Tests		Dynamic Tests	
	Loading Rate 1/2 in. per min.		Loading Rate 45 FPS	
	Load at Failure (lb)	Load at Failure (lb)	Load at Failure (lb)	Load at Failure (lb)
A* 3/8**	340	502	955	
A 5/8	420	600	1015	
B 3/8		420	780	
B 5/8		430	1190	
C 3/8		775	1310	
C 5/8		952	1500	
D 3/8		220	210	
D 5/8		714	850	

\*Test Types

\*\*Test Types

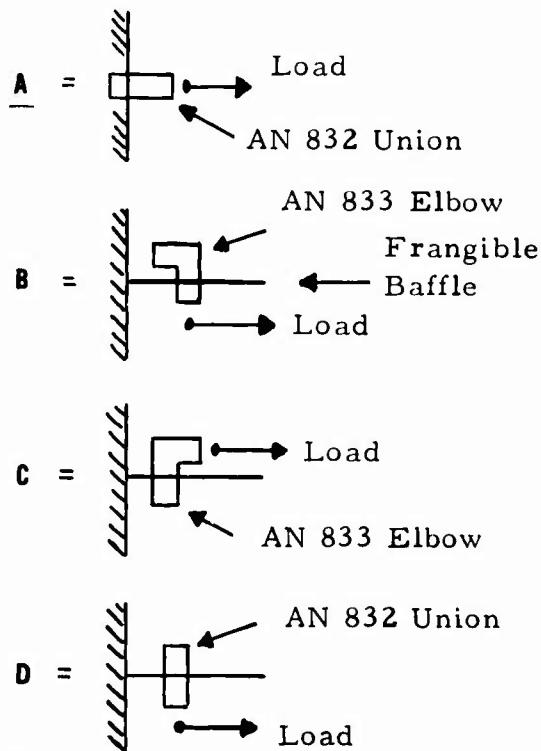

3/8 = 3/8 in. fitting size

5/8 = 5/8 in. fitting size

APPENDIX VI  
FRANGIBLE FASTENER TESTS

OBJECTIVE

A series of tests was conducted to determine the failure loads of selected bolts and studs to be used as frangible fasteners. The fasteners were designed to serve as frangible connectors to attach various components to the airframe.

TEST ITEMS

Six basic fastener configurations were tested, all of the 1/4-inch-diameter, 20 -threads-per-inch configuration.

<u>CONFIGURATION</u>	<u>DESCRIPTION</u>
A	Aluminum studs (2024-T4)
B	Aluminum round head machine screws (2024-T4)
C	Standard aluminum machine bolts (2024-T4)
D	Standard aluminum machine bolts (2024-0)
E	Aluminum 100-degree countersunk machine screws (2024-T4)
F	Fiber glass/polyester resin studs

TEST METHOD

The six fastener configurations were tested in several modes. Some of the basic configurations were modified to vary the failure load. All tests were conducted on a tensile test machine with the load being applied at the rate of 1/2-inch-per-minute. A discussion of each test series follows.

Configurations A, B, C, and D

These configurations were statically tested in both the tension and shear mode. The fixtures, in schematic form, are shown in Figure 86.

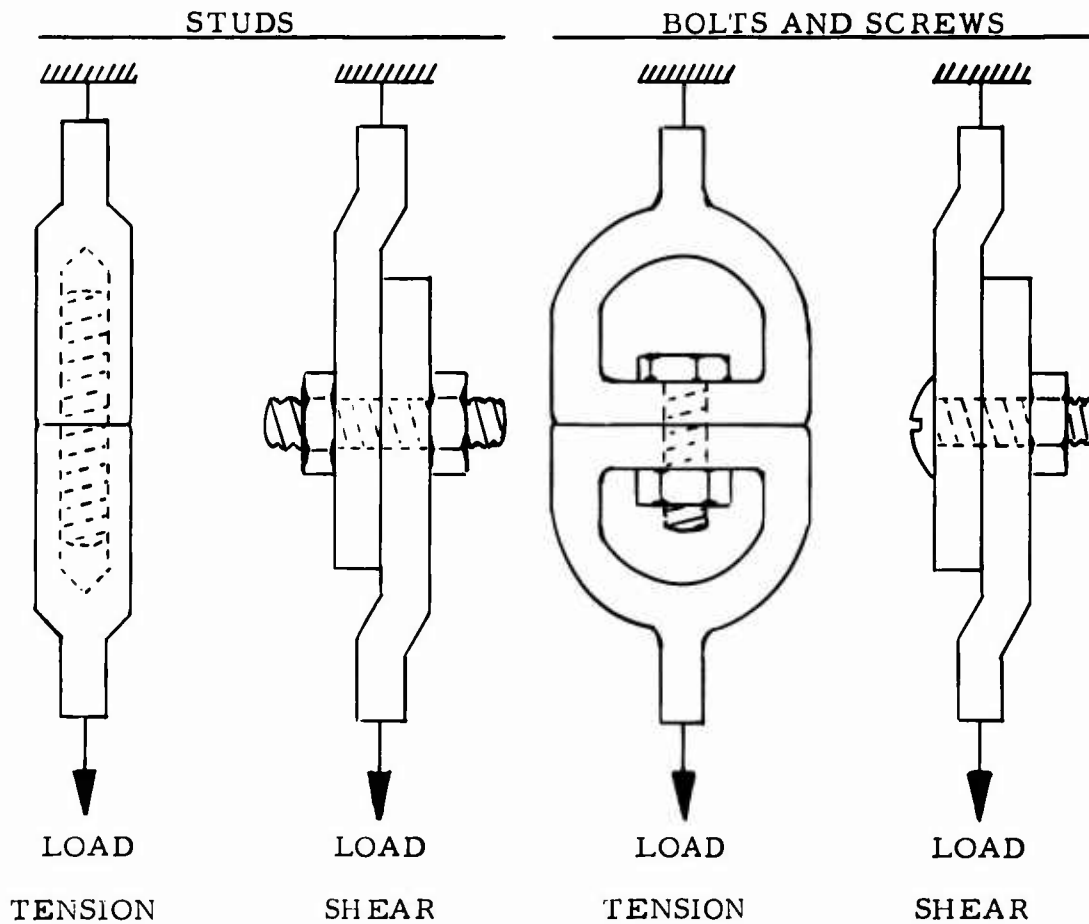

Figure 86. Test Fixture for Single Fastener Static Tests.

Configurations A and B were also tested in a 12-group pattern that duplicated the installation at the fuel boost pump mounting plate. The test fixture, in schematic form, is shown in Figure 87.

Some of the fasteners were modified to cause them to fail at a load considerably below that of the solid configuration. The modification consisted of drilling various size holes lengthwise through the threaded shaft. Some of the holes were circular and some were broached hexagonally to conform to various Allen wrench sizes.

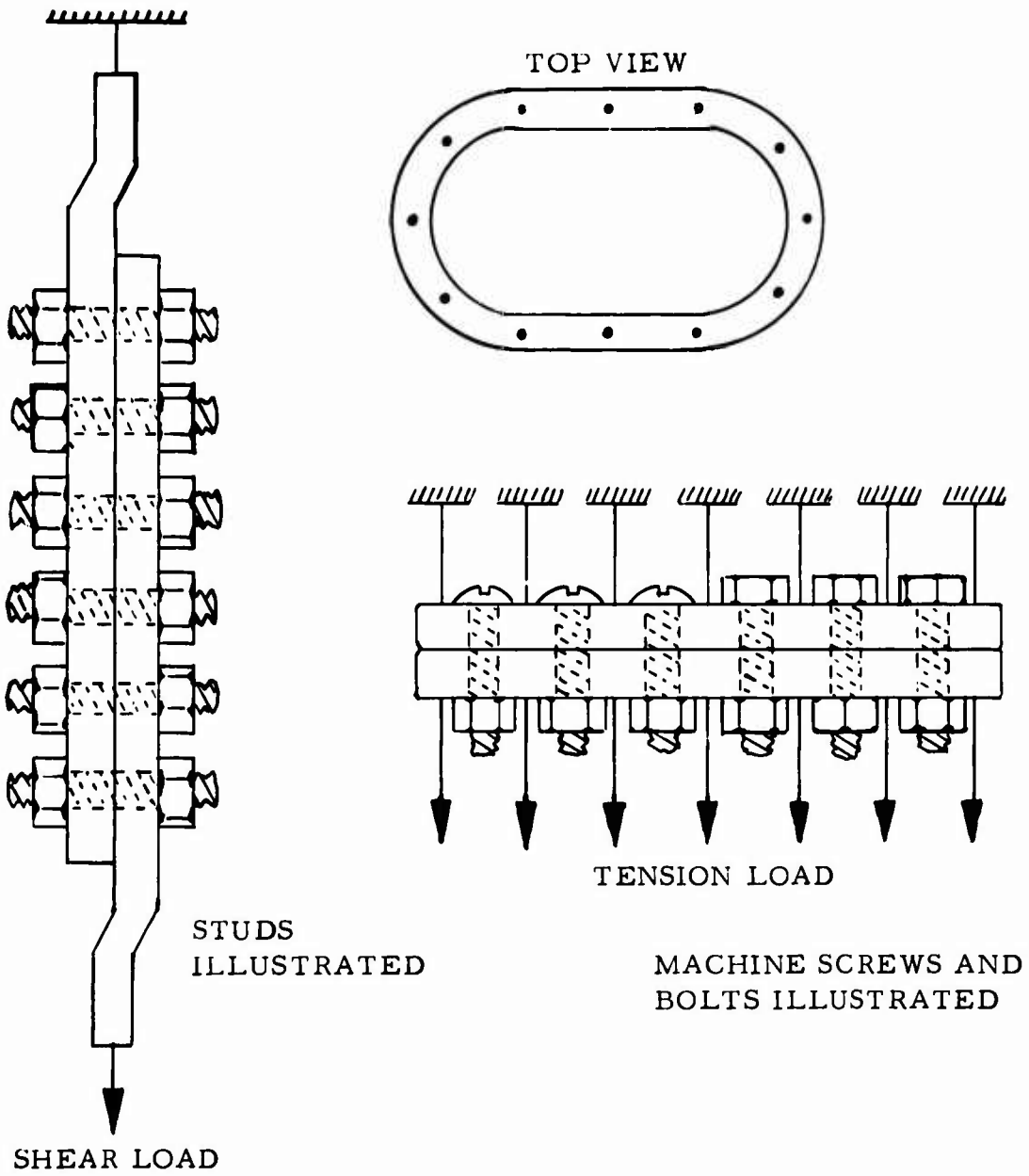

Figure 87. Test Fixture for 12-Fastener Grouping Simulating Boost Pump Mounting Plate.

The results of tests conducted on configurations A, B, C, and D are shown in Table X.

TABLE X. FRANGIBLE FASTENER TEST RESULTS - CONFIGURATIONS A, B, C, AND D					
Configu- ration	Test Item	Multiple Test Averages			
		Tension		Shear	
		Torque Setting (in.- lb)	Failure Load (lb)	Torque Setting (in.- lb)	Failure Load (lb)
A	Aluminum studs (2024-T4)				
	Single stud (solid)	20	503	20	363
	Single stud (1/8 in. hole)	20	318	20	171
	Twelve-stud combination	20	6040	20	4350
B	Aluminum round head machine screws (2024-T4)				
	Single screw (solid)	20	506	20	361
	Single screw (1/8 in. hole)	20	318	20	169
	Twelve-screw combination	20	6052	20	4340
C	Standard aluminum machine bolts (2024-T4)				
	Single bolt (7/64 in. Allen hole)	20/40	1125/ 983	32	681
	Single bolt (1/8 in. Allen hole)	25	876	32	481
	Single bolt (9/64 in. Allen hole)	20	400	15	240
D	Standard aluminum machine bolts (2024-0)				
	Single bolt (1/8 in. Allen hole)	15	394	10	272

Configuration E

Configuration E (2024-T4 aluminum countersunk machine screws) was statically tested in the tension mode. The screws were installed in two different hole geometries. As a base reference, a standard 100-degree countersunk hole was used. The screws were then tested in a 100-degree countersunk hole which was slotted. Sketches illustrating each hole geometry, and the data obtained during each test series, are presented in Table XI.

TABLE XI. FRANGIBLE FASTENER TEST RESULTS - CONFIGURATION E			
Configu- ration	Test Item	Multiple Test Averages	
		Torque Setting (in.-lb)	Tension Failure Load (lb)
E	Aluminum 100-degree countersunk machine screw (2024-T4)		
	Single bolt (standard hole)	20	459
	Single bolt (slotted hole)	20	456

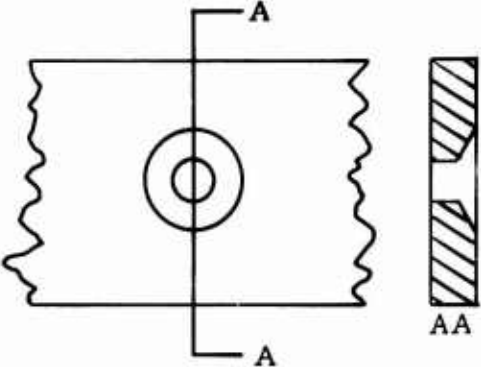

STANDARD HOLE

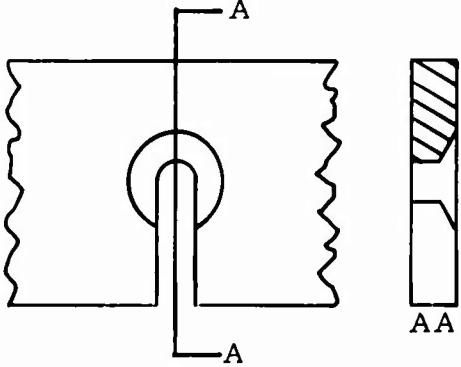

SLOTTED HOLE

Configuration F

Configuration F consisted of threaded studs made of a fiber glass cloth/ polyester resin laminate. The studs were statically tested in both the tension and shear mode. Two types of studs were manufactured to provide various failure loads. Type A had fewer windings of glass cloth, whereas Type B had the maximum amount of fiber glass cloth practical to place in the stud shape. The results of the test series are shown in Table XII.

TABLE XII. FRANGIBLE FASTENER TEST RESULTS - CONFIGURATION F					
Configu- ration	Test Item	Multiple Test Averages			
		Tension		Shear	
		Torque Setting (in.-lb)	Failure Load (lb)	Torque Setting (in.-lb)	Failure Load (lb)
F	Fiber glass/polyester resin studs				
	Single stud (Type A)	20	149	20	71
	Single stud (Type B)	20	185	20	114

APPENDIX VII  
METHOD FOR DETERMINING THE YIELD VALUE OF  
EMULSIFIED FUELS BY CONE PENETRATION

SCOPE

This method covers a procedure to measure the yield value of emulsified fuels and is a modification of ASTM Designation: D217-65T, Tentative Method of Test for Cone Penetration of Lubricating Grease.

DEFINITION

Penetration is the depth in tenths of a millimeter that a 30-gram cone assembly penetrates the sample under prescribed test conditions.

Yield value represents the stress in dynes/cm<sup>2</sup> required to cause the emulsified fuel to flow.

SUMMARY OF METHOD

A cup was filled with emulsified fuel and was stabilized at  $76 \pm 4^{\circ}\text{F}$ . The surface was leveled and smoothed, and the cone assembly of the penetrometer was released for 5 seconds. The depth of penetration was shown on a dial indicator of the penetrometer. The penetration depth, the cone weight, and the cone dimensions were used to calculate the yield value of the fuel under test.

APPARATUS

Penetrometer

A penetrometer, similar to that shown in Figure 88, was used to measure the penetration of the cone in the fuel. The cone assembly, or the table of the penetrometer, was adjusted to enable accurate placement of the tip of the cone on the level surface of the fuel while maintaining a "zero" reading on the indicator. When released, the cone fell without appreciable friction for at least 4.00 centimeters, and the tip of the cone did not hit the bottom of the sample container. The instrument was leveled with leveling screws and a spirit level to maintain the cone shaft in a vertical position.

Cone and Rod Assembly

A cone manufactured of plastic having an aluminum tip and stem and

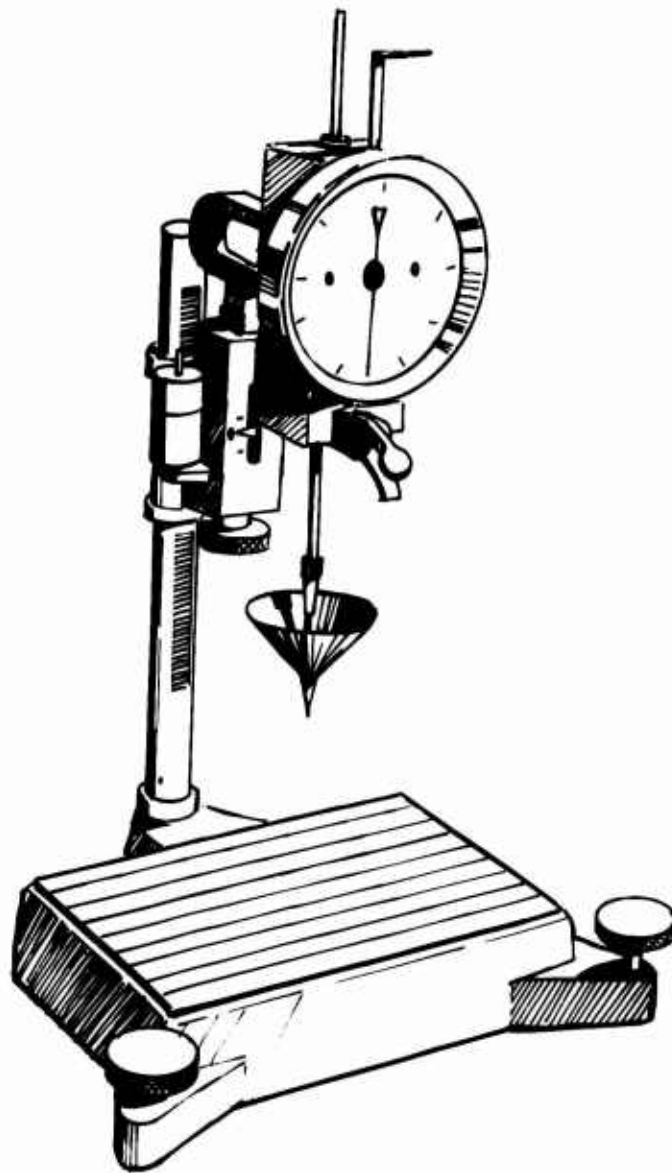

Figure 88. Penetrometer.

conforming to the dimensions shown in Figure 89 was used. A rod manufactured of aluminum and weighing  $15 \pm 0.05$  grams was used to support the cone. The combined weight of the cone and rod assembly was  $30 \pm 0.1$  grams.

Aluminum containers for the samples exceeded the requirements for a minimum inside diameter of 3-13/16 inches and a minimum height of 2-1/2 inches.

### PROCEDURE

An emulsified fuel sample was placed in the container in such a manner as to remove large air pockets that may have been entrained. The surface of the sample was smoothed and leveled with the lip of the container by scraping with a spatula. The penetrometer was leveled with the aid of the leveling screws and the spirit level. The cone was carefully cleaned before each test. The mechanism to hold the cone in the "zero" position was then set. The sample container was placed on the penetrometer table, and the assembly was lowered so that the tip of the cone just touched the surface at the center of the sample. (Watching the shadow of the cone tip was an aid to accurate setting.) The cone shaft was then rapidly released and allowed to drop for  $5.0 \pm 0.1$  seconds. The release mechanism did not drag on the shaft. The indicator shaft was then gently pressed downward until it was stopped by the cone shaft and was then read from the indicator dial. The surface was then carefully releveled, and two additional readings were taken in different locations by the same method. The yield value was obtained from the graph in Figure 90.

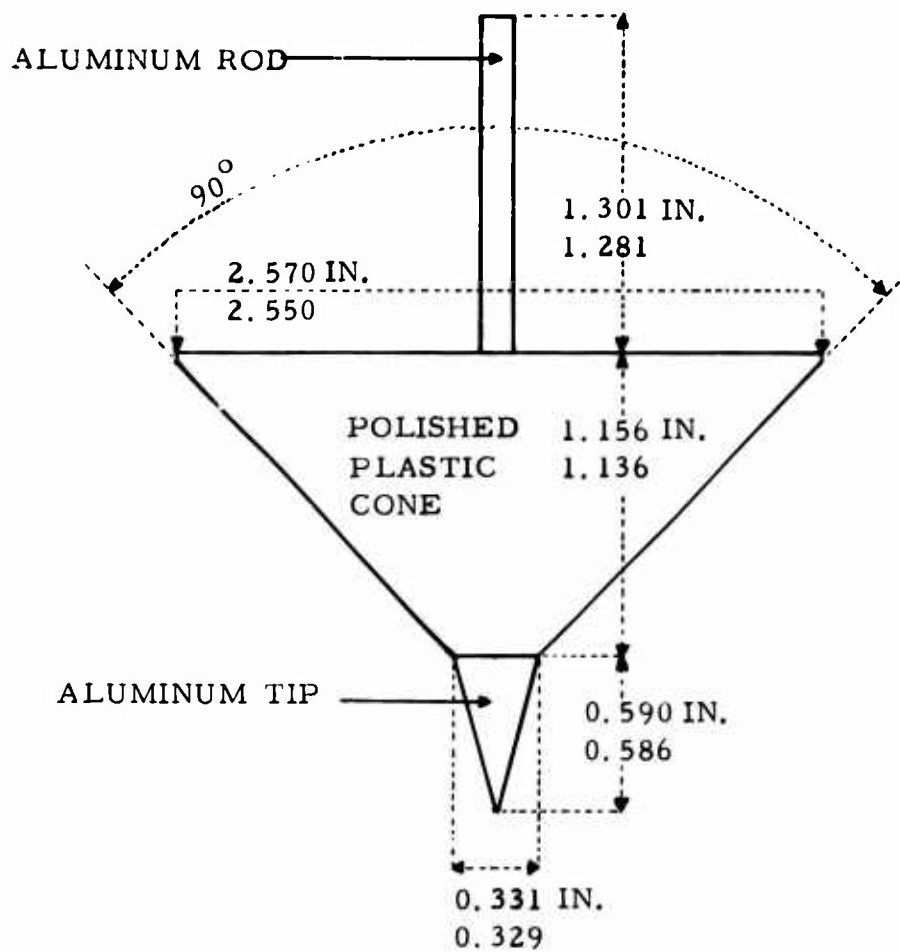

Figure 89. Penetrometer Cone.

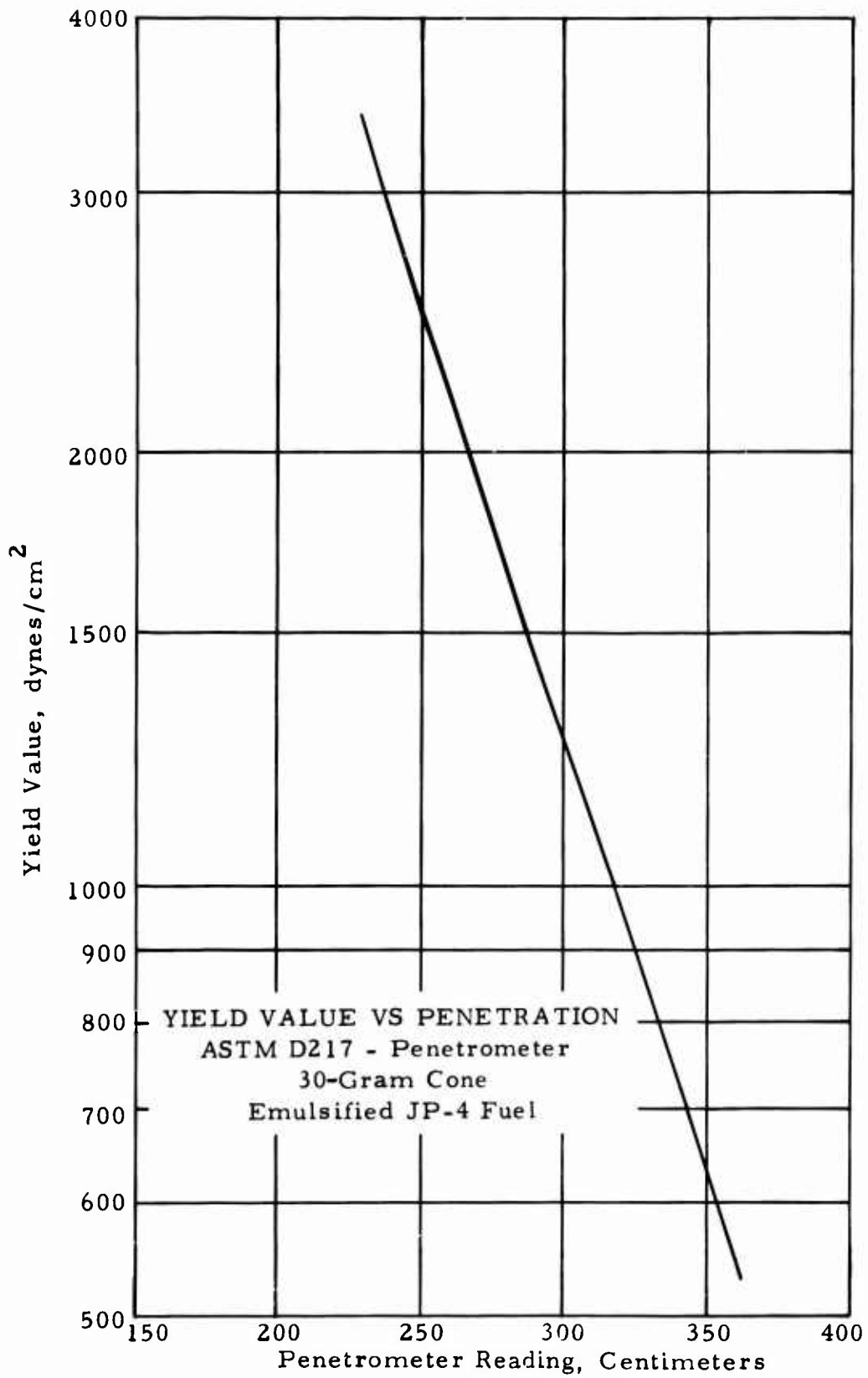

Figure 90. Yield Value Versus Penetration Graph.

APPENDIX VIII  
FRANGIBLE CABLE CLAMPS AND ELECTRICAL WIRE TESTS

OBJECTIVE

A series of tests was conducted to determine the load capabilities of selected "off-the-shelf" electrical cable clamps and wires in shear and tension modes. The feasibility of the frangible clamps as replacements for rigid metal clamps was evaluated.

TEST ITEMS

Two types of frangible loop-type clamps were tested. The first was a Teflon clamp in a standard loop configuration; see Figure 91. The second type, a nylon clamp, is a loop type with a self-locking feature that adjusts to the diameter of the cable being supported; see Figure 92.

Single strands of electrical wires (20, 18, and 8 gauge) were tested. Standard wiring installed on military aircraft was removed for the test items.

A standard cushioned loop-type metal support clamp was tested for comparison with the frangible clamps.

TEST METHOD

All of the clamps were tested statically, and the nylon clamp was also tested dynamically. A Dillon universal test machine was used to apply the static loads. The mounting angle of the test items was changed to achieve tension and shear applications. A drop tower was used for dynamic loading, with the nylon clamps mounted in different positions for shear and tension load applications. A 10-pound weight was attached to each test clamp, and the clamps were mounted in a cage on the drop tower. A 10-foot free fall of the drop cage onto a prepared sandpile loaded the test items at a 5000 to 6000G onset rate.

The electrical wires were tested in a straight tension mode on a Dillon universal tester. The wires were rolled around 1/2-inch rods to secure them in the tester (Figure 93).

INSTRUMENTATION

A strain link measured the loads applied on the Dillon universal tester,

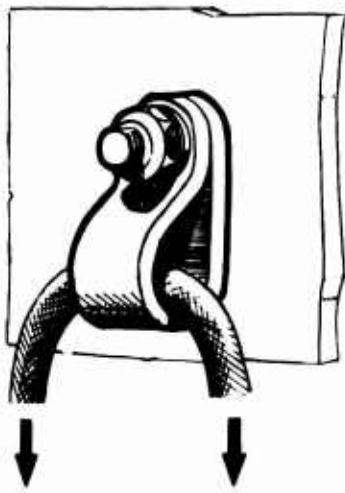

SHEAR LOAD

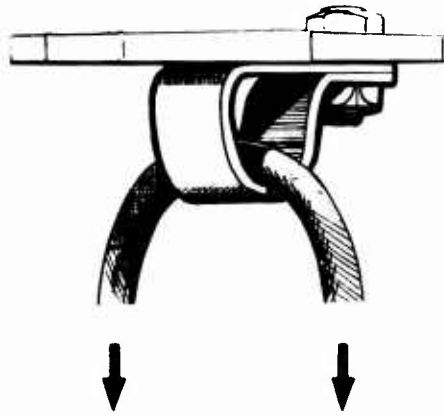

TENSION LOAD

Figure 91. Test Load Application for Teflon Cable Clamp.

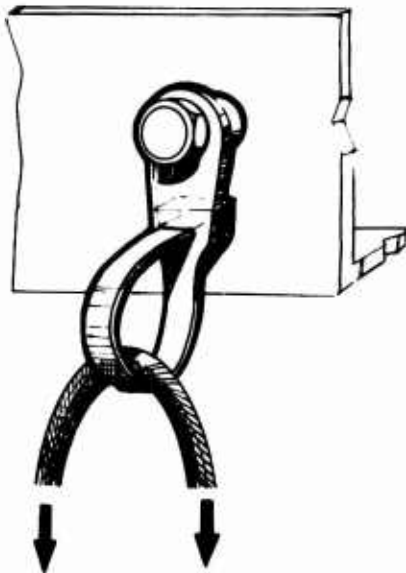

SHEAR LOAD

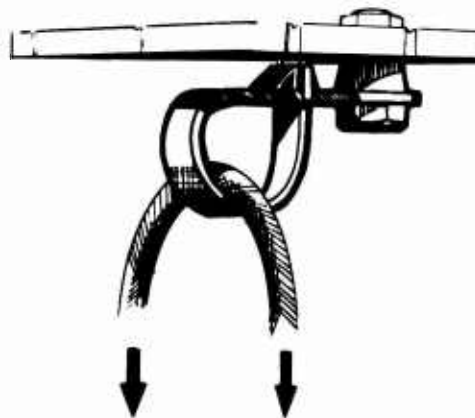

TENSION LOAD

Figure 92. Test Load Application for Nylon Cable Clamp.

and the force was read directly on a strain indicator.

A Statham A-5-100G accelerometer, mounted on the drop cage, measured the accelerations experienced in the drop tower tests. The accelerometer was linked to an oscillographic recorder located adjacent to the drop tower.

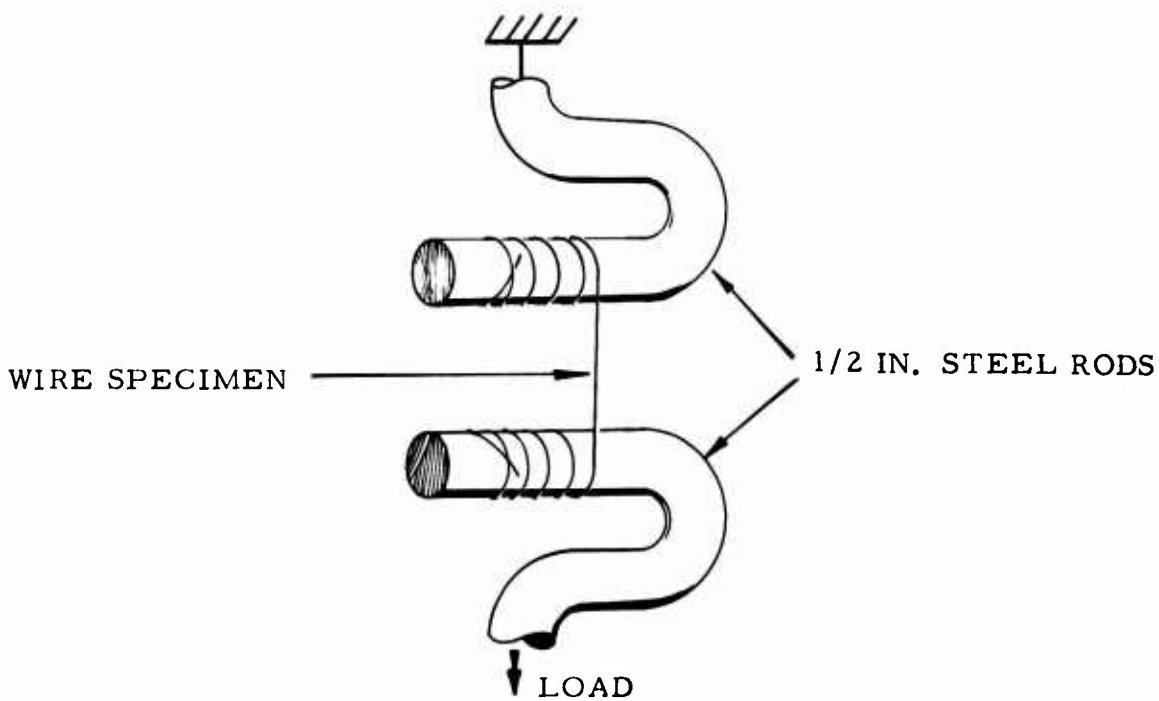

Figure 93. Wire Pulling Technique.

## TEST RESULTS

### Teflon Clamps

The results obtained from the static tests of the Teflon clamps are presented in Table XIII.

### Nylon Clamps

Results of the static tests of the nylon clamps are shown in Table XIV. The nylon clamps failed in both the shear and tension modes in the drop tower tests. The 10-pound weights, appended beneath the clamps on the cables, failed the clamps in a clean break in each test. Peak accelerations of 65G were recorded on the drop cage.

TABLE XIII. TEFLON CABLE CLAMP TESTS			
Test No.	Size Clamp (in.)	Mode	Load at Failure (lb)
1	3/8	Shear	42.42
2	3/8	Tension	52.53
3	1/8	Shear	46.46
4	1/8	Tension	56.57

TABLE XIV. NYLON CABLE CLAMP TESTS		
Test No.	Mode	Load at Failure (lb)
1	Shear	69.4
2	Shear	78.46
3	Tension	71.93
4	Tension	69.75

### Electrical Wires

Table XV presents the results of the static tests of three sizes of aircraft electrical wires.

TABLE XV. ELECTRICAL WIRE TESTS (TENSION)			
Test No.	Type Wire	Gauge	Load at Failure (lb)
1	K2A20	20	70.2
2	L42A20	20	67.2
3	H7D18	18	69.0
4	A2A18	18	64.8
5	RF438A20 (Shielded)	20	50.4
6	RF443A20 (Shielded)	20	60.0
7	RL2600A8	8	352.2

#### Cushioned Metal Clamps

Results of static tension and shear loading on the rigid metal clamps are shown in Table XVI.

TABLE XVI. ALUMINUM ALLOY LOOP-TYPE SUPPORT CLAMP TESTS			
Test No.	Size Clamp (in. )	Mode	Load at Failure (lb)
1	5/8	Shear	1,149.84
2	5/8	Tension	332.79

## CONCLUSIONS

The frangible clamps tested possess more than adequate load-carrying capabilities to support and restrain aircraft electrical wires under all normal flight conditions.

The strength of a single strand of most of the electrical wires tested is sufficient to fail the frangible clamps tested. Wire assemblies of more than one strand of the wires (normal usage) will fail the frangible clamps.

Testing under extreme environmental conditions is warranted to further validate the operational acceptance of the frangible clamps.

APPENDIX IX  
VERTICAL DROP TEST OF A  
CRASH-RESISTANT FUEL AND LUBRICATING OIL SYSTEM

TEST OBJECTIVE

To determine the structural integrity and effectiveness of the modified UH-1A fuel and lubricating oil systems when subjected to severe vertical loading on simulated rough terrain.

TEST ITEMS

The fuel tank section of a UH-1A helicopter that served as the test vehicle for a full-scale crash test was prepared for a drop tower test. The fuel tank section lies between FS 123.0 and FS 174.0. All structure outside of this area and above the engine service deck was removed. The test fuselage section is shown in Figures 94 and 95.

The production UH-1A fuel system had been modified to provide a crash-worthy fuel system for the full-scale crash test. In general, these modifications consisted of the following:

1. The two original fuel cells were removed, and two crash-resistant cells were installed in their place. The new cells were of the same capacity (138 gallons total) and configuration as the original ones; see Figure 2.
2. The two original metal fuel tank crossover tubes were removed and replaced with flexible ones. The large aft tube was replaced with a two-piece assembly made of material similar to the tank. The forward crossover tube was replaced by flexible wire-braid-covered hose joined with appropriate fittings. Both assemblies are shown in Figure 2.
3. Self-sealing breakaway valves were installed:
  - a. At each end of the forward crossover assembly.
  - b. Where the main fuel supply line exits the left cell.
  - c. At each end of the aft crossover assembly.
4. The standard plastic fuel quantity indicator was installed in the left cell.

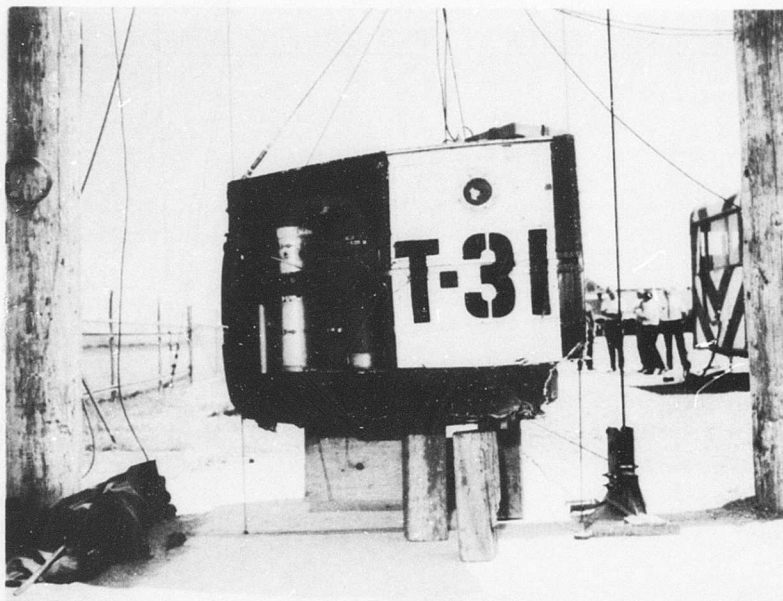

Figure 94. Right Side of Test Fuselage Section.

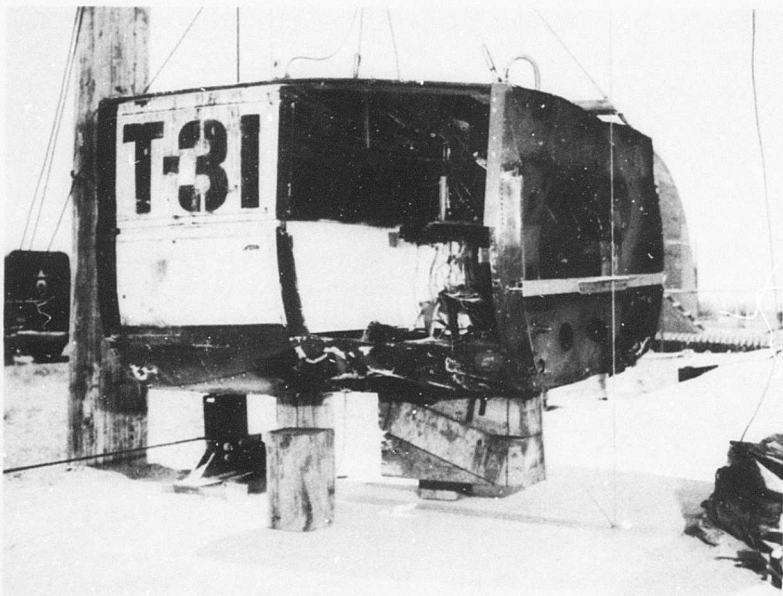

Figure 95. Left Side of Test Fuselage Section.

5. A frangible coupling was installed between the fuel tank filler cap assembly and the aircraft structure in the right cell.
6. Frangible aluminum screws were used to attach the boost pump to the structure in the bottom of the left cell cavity. The power leads to the pump were routed inside the cell through a flexible hose that exited the cell at the top through a bulkhead fitting.
7. A frangible coupling was used to attach the left cell to the cavity wall where the main fuel line exits the cell.
8. The helicopter fuel tank system was filled with emulsified JP-4 fuel, and the aircraft engine was operated on the emulsion during the full-scale crash test. The emulsion was removed after the crash test and was replaced with water for the drop test.

The lubricating oil system of the UH-1A had also been modified extensively for the full-scale crash test. In the drop test, only the following modifications were retested:

1. The oil cooler had been rotated 90 degrees in position to place the inlet and outlet fittings on top of the cooler away from possible strike damage on the right side, as shown in Figure 24.
2. The cooler-to-engine line passed through the service deck by means of a self-sealing quick disconnect. This valve was secured in a stainless-steel triggering valve mount that was installed flush with the top of the service deck. The line was included in the drop test to determine if the inertial mass of the valve body would cause valve separation under high vertical loading.

The system modifications mentioned heretofore were fully functional when the UH-1A helicopter was crash-tested by means of a radio-controlled flight system. The crash was severe, and the crashworthiness modifications were credited with preventing a fire on impact and during the long, destructive slide after impact. The vertical loading component of the impact was not sufficient to activate certain system components that had been modified. The purpose of the drop test was to impose severe vertical loading and to determine the systems' reactions to rough terrain impact.

The test section weighed 1625 pounds, of which 1160 pounds was water.

## TEST CONDITIONS

The vertical drop tower was used to hoist the fuselage section to a height of 30 feet. A three-point sling was attached to the top of the section, and cable guides were installed to stabilize the fuselage section during descent.

The rough terrain simulation was achieved by:

1. Positioning vertically on the impact pad a 20-inch length of railroad tie oriented to impact the right tank bottom.
2. Attaching vertically a 20-inch length of tie beneath the aft crossover assembly just inboard of the attachment to the right tank.
3. Attaching vertically a 21-inch length of tie beneath the left side of the forward crossover assembly.
4. Attaching two horizontal ties, secured one on top of the other (28 inches long by 14 inches high), parallel to the centerline, beneath the oil cooler installation.
5. Positioning vertically a 14-inch length of tie beneath the fuel boost pump installation.

Placement of the railroad ties is shown in Figures 94 and 95. The tie length was adjusted to allow each tested component to receive its impact at approximately the same time, thus reducing any overturning or pitching movement which would otherwise occur in the fuselage.

## INSTRUMENTATION

An accelerometer was installed on top of each cell cavity to record vertical accelerations. Five high-speed cameras were located around the impact area. Still and motion pictures were taken before and after the test.

## TEST RESULTS

The fuselage section impacted flatly onto the pad, completely enveloping the railroad ties positioned beneath. The posttest position of the section is shown in Figures 96 and 97. The condition of the bottom of the section can be seen in Figure 98. The vertical accelerations recorded atop

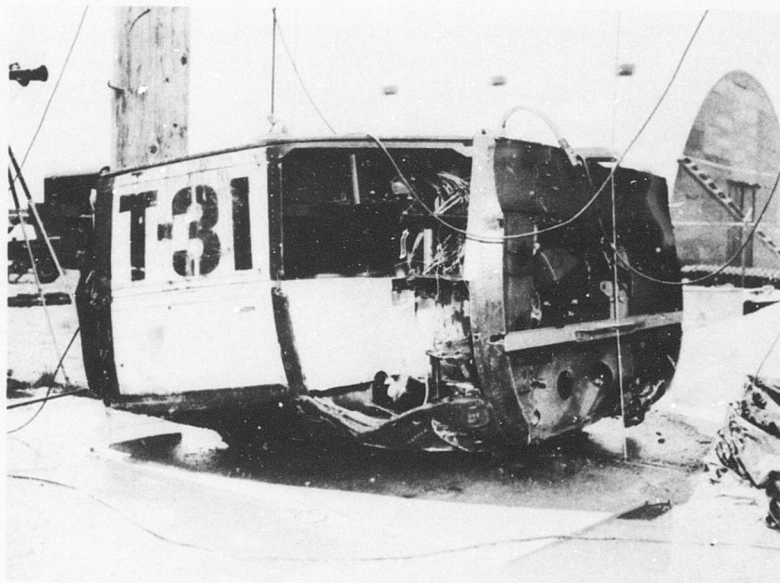

Figure 96. Posttest View of Section - Left and Rear Sides.

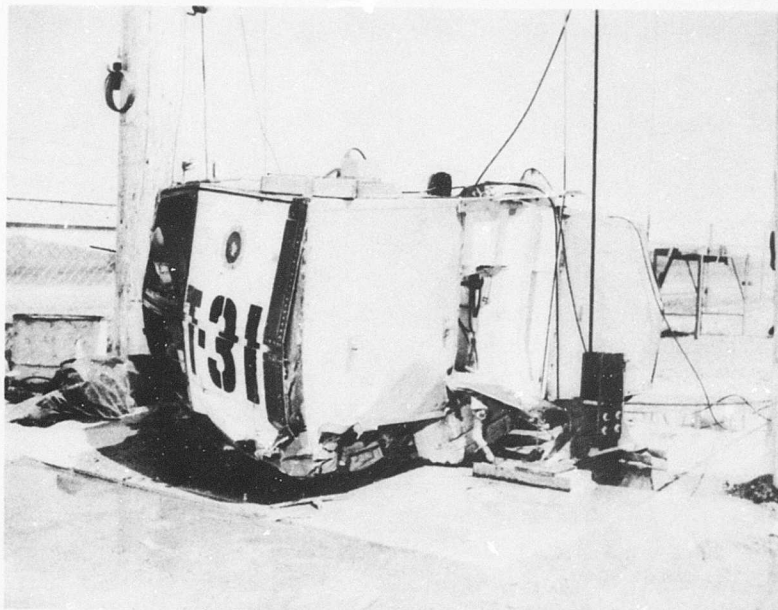

Figure 97. Posttest View of Section - Right and Front Sides.

the fuel cell cavities had an average peak value of 145G; see Figures 99 and 100.

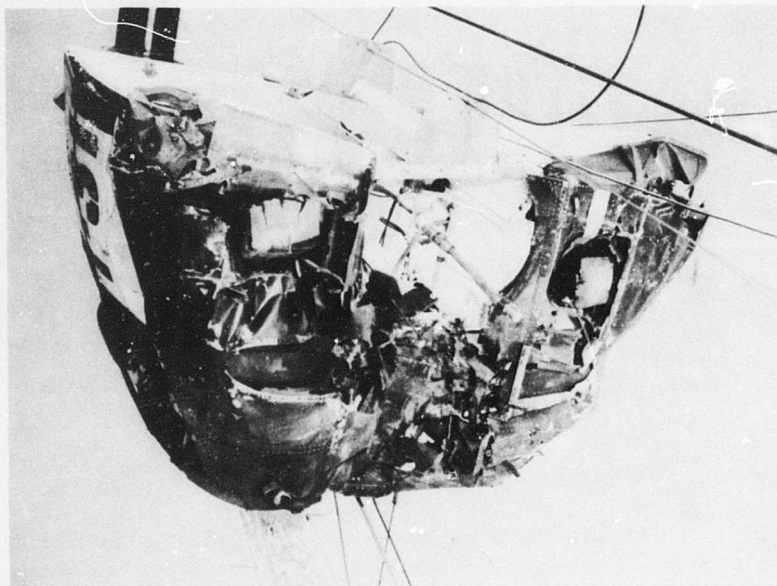

Figure 98. Posttest Condition of Bottom of Fuselage Section.

### Fuel System

The tie beneath the left fuel cell impacted the boost pump, driving it and the mounting diaphragm upward. A rip in the cell material commenced at the pump opening and ran rearward to the aft bottom edge of the cell. A rip and a large opening were created (Figure 101) as the attaching hardware in the pump mounting diaphragm pulled through the cell material (Figure 102). An interior cell view, showing that the tie penetrated the cell and that the electrical power leads to the pump were not damaged in their protected position inside the flexible hose, is shown in Figure 103. The quantity indicator collapsed (Figure 104) as the bottom of the cell moved upward.

The self-sealing quick disconnect connecting the engine fuel line to the left cell did not separate, since there was adequate length to the line to preclude its being placed in tension. The frangible connector between the cell and cavity wall did separate as designed. The broken cavity wall attachment and the part of the connector that remained and displaced with

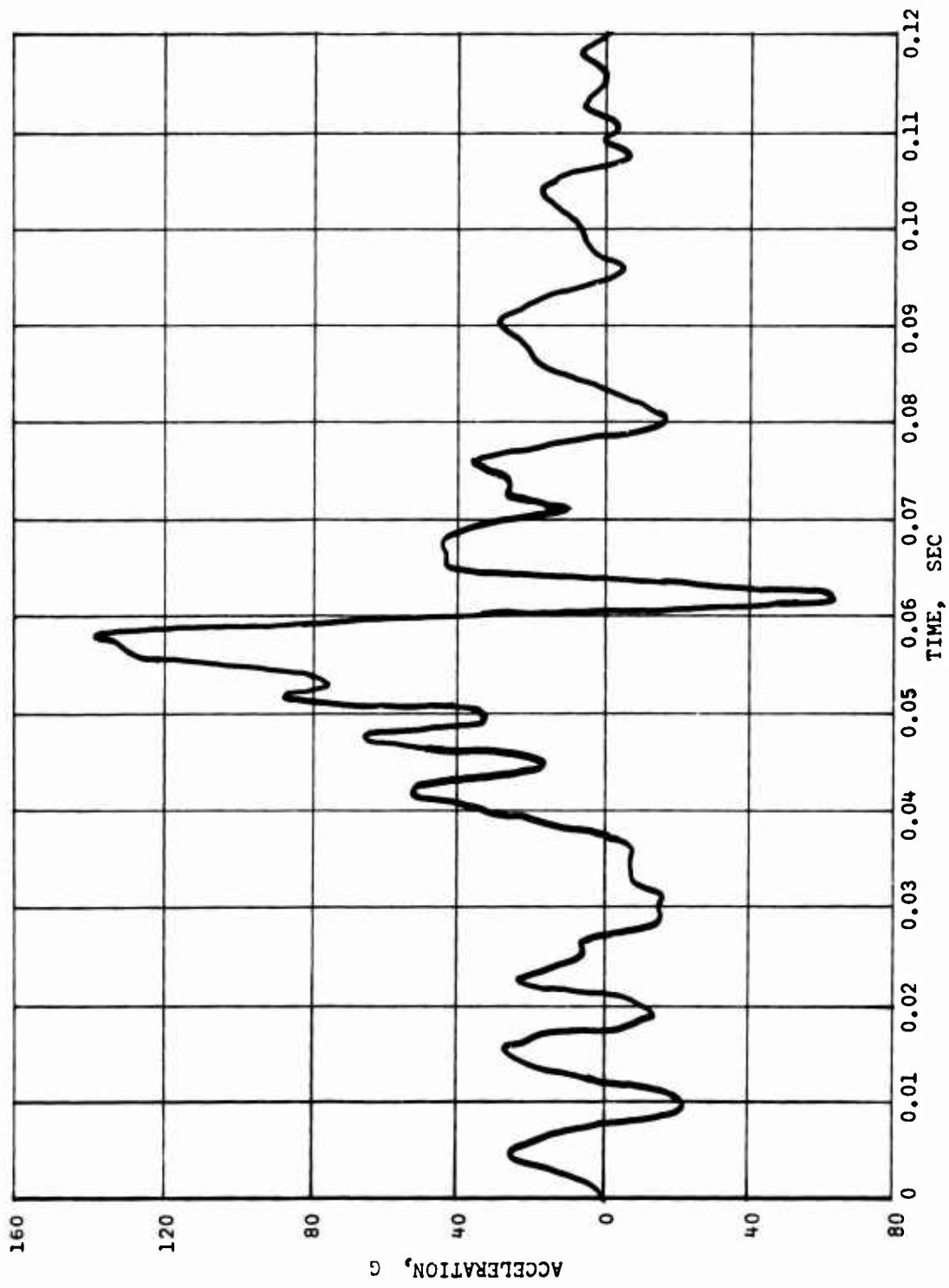

Figure 99. Acceleration - Time History Recorded on Top of Left Fuel Cell.

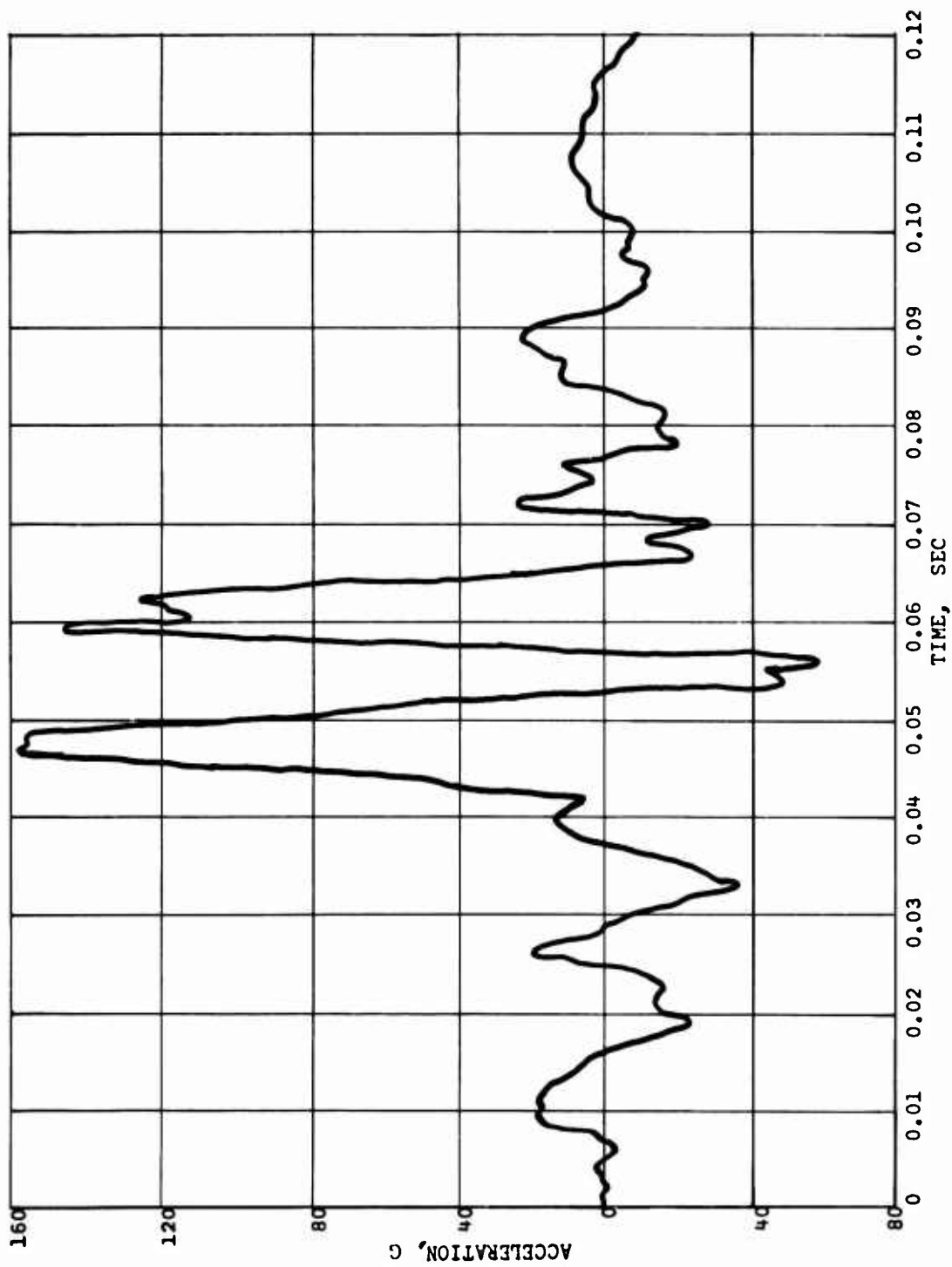

Figure 100. Acceleration - Time History Recorded on Top of Right Fuel Cell.

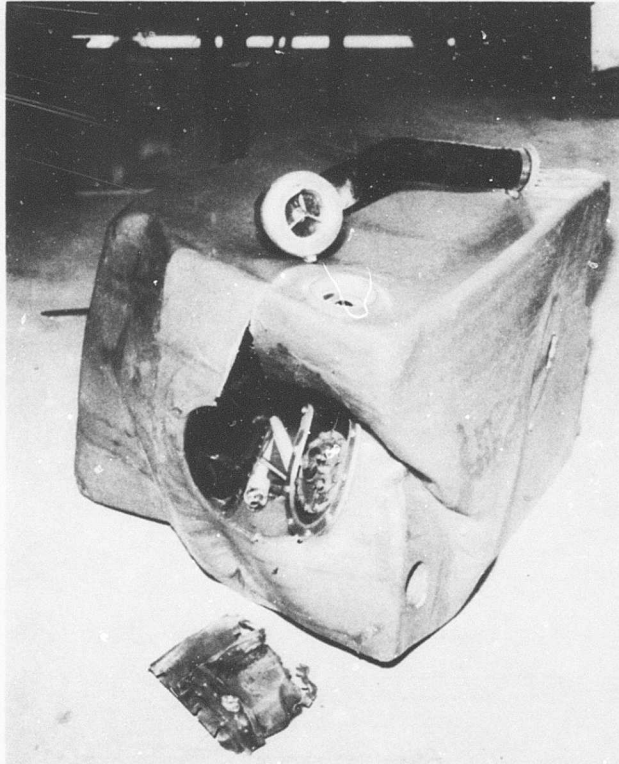

Figure 101. Posttest Bottom View of Left Fuel Cell.

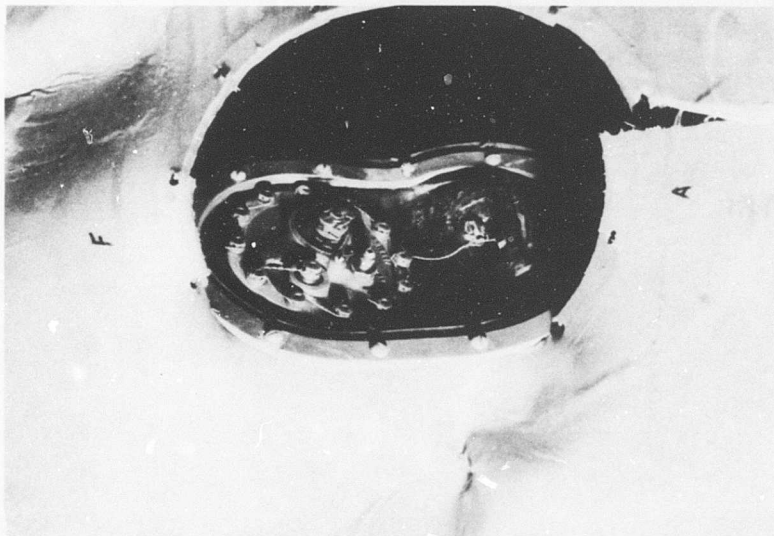

Figure 102. Damage to Boost Pump and Fuel Cell.

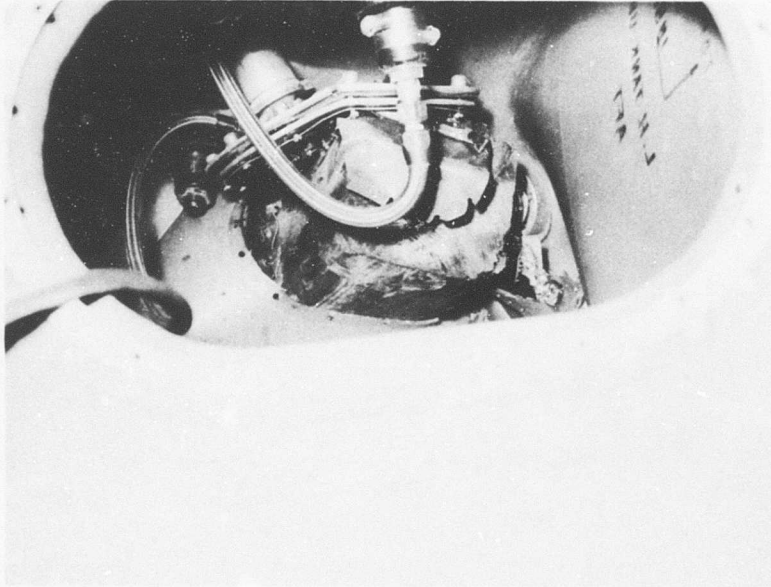

Figure 103. Railroad Tie Penetration Into Left Cell.

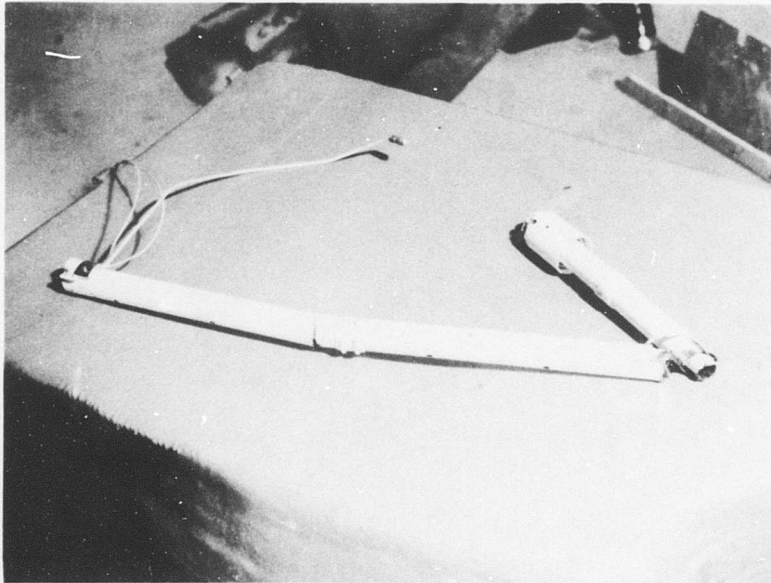

Figure 104. Fuel Quantity Indicator After Test.

the fuel cell are shown in Figures 105 and 106, respectively.

The right cell was severely impacted on the bottom but did not rupture. The internal pressure built up by volume reduction caused by the tie intrusion (approximately 12-inch penetration) was maintained until released after impact. The tie remained imbedded in the structure and cell after the fuselage section was hoisted off the impact pad, as shown in Figure 98. The only visible damage to the cell material was some exterior surface mars caused by torn structure on the bottom.

The frangible ring between the right cell filler cap assembly and the airframe was not loaded high enough to cause separation.

The forward crossover assembly was impacted near the self-sealing quick-disconnect connection to the left cell. The left disconnect separated from the cell and closed. The crossover disconnect connection to the right cell remained attached. There was no leakage from the assembly. All of the water in the left cell exited through the boost pump opening. Both self-sealing quick disconnects were still capable of functioning after the cells were removed from the fuselage section, as shown in Figures 107 and 108. The posttest condition of both crossover assemblies is shown in Figure 109.

The aft crossover tube separated from each fuel cell at the self-sealing breakaway interconnect. The disconnects from the right and left cells are seen in Figures 110 and 111. The interconnect halves that remained in the cells closed and sealed as intended. Both interconnects in the crossover tube closed; however, only the right one sealed completely.

The left interconnect was prevented from sealing completely by a displaced O-ring. The interconnect leaked at a rate of approximately 1/2 pint per minute. The interconnect separations after the cells and the crossover had been removed from the test section are posed in Figures 112 and 113.

#### Lubricating Oil System

The oil system components were severely impacted, but no failures resulted.

The bottom of the oil cooler received a severe blow. A front view of the cooler is shown in Figure 114. The cooler can barely be seen behind the fan, as shown in Figure 115, a rear view. Deformation caused by impact with the railroad tie on the bottom of the unit is shown in Figure 116.

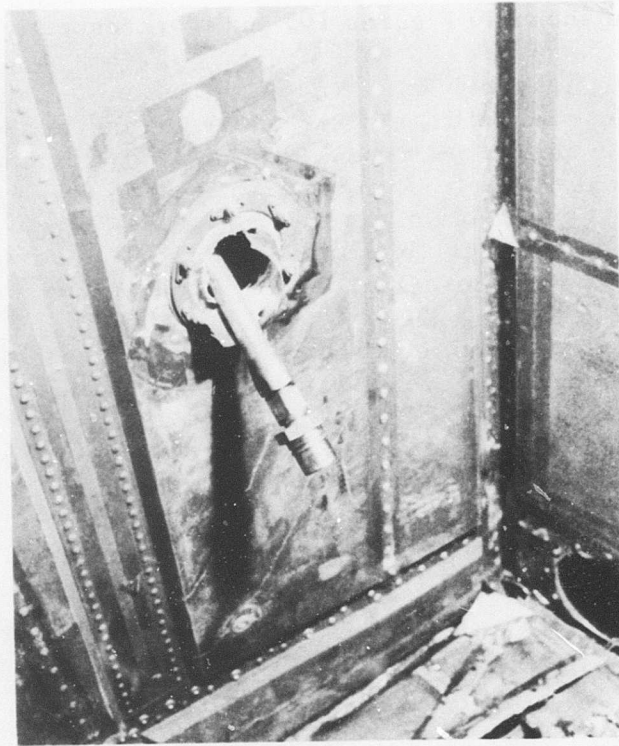

Figure 105. Posttest View of Frangible Tank Wall Stabilizer at the Tank-to-Engine Fuel Line Airframe Opening.

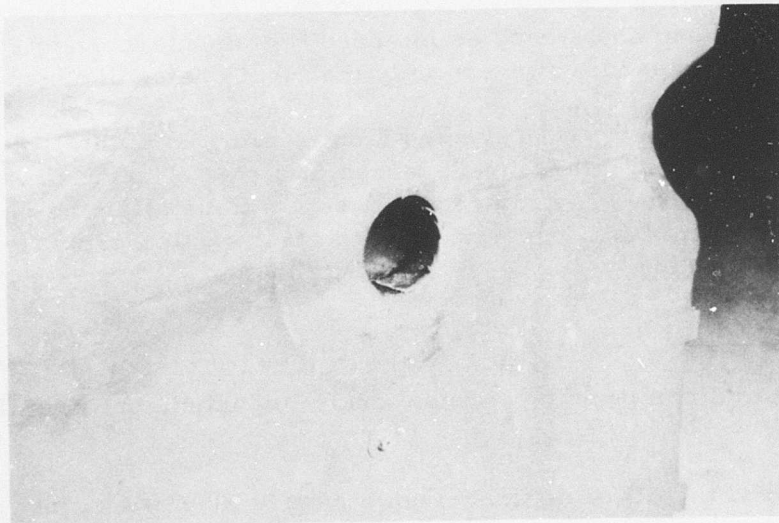

Figure 106. Remains of the Frangible Tank Wall Stabilizer Surrounding the Tank-to-Engine Tank Outlet.

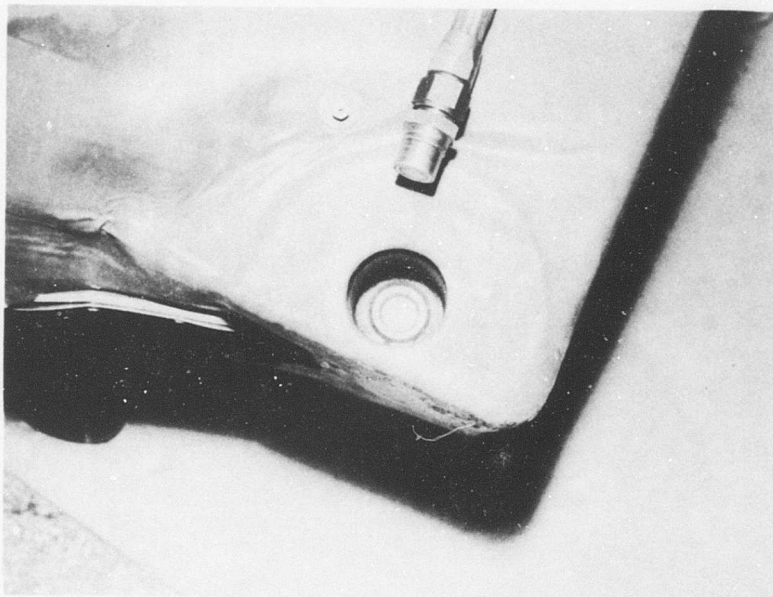

Figure 107. Posttest Position of Breakaway Valve in Forward Crossover Attachment to Left Cell.

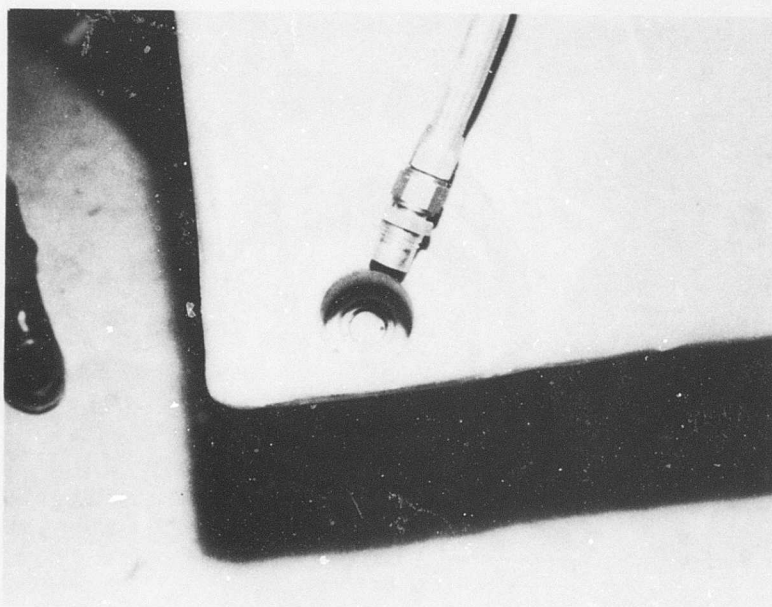

Figure 108. Posttest Position of Breakaway Valve in Forward Crossover Attachment to Right Cell.

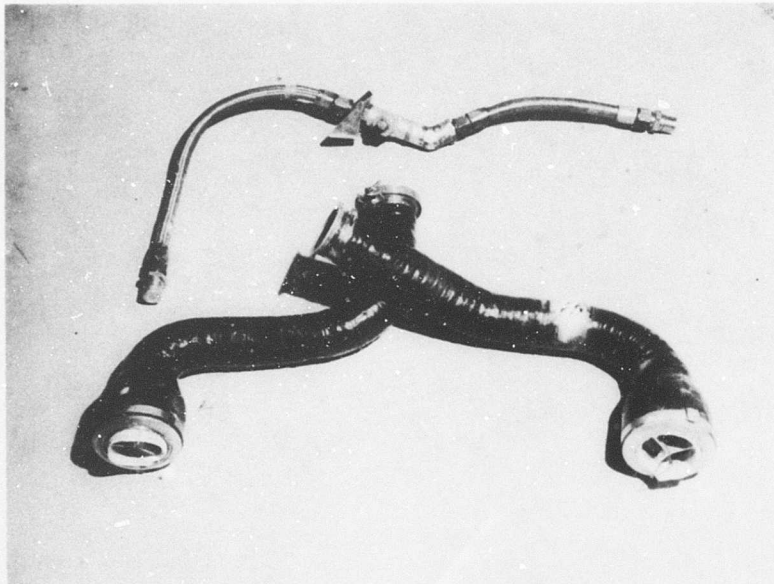

Figure 109. Forward and Aft Crossover Assemblies After the Test.

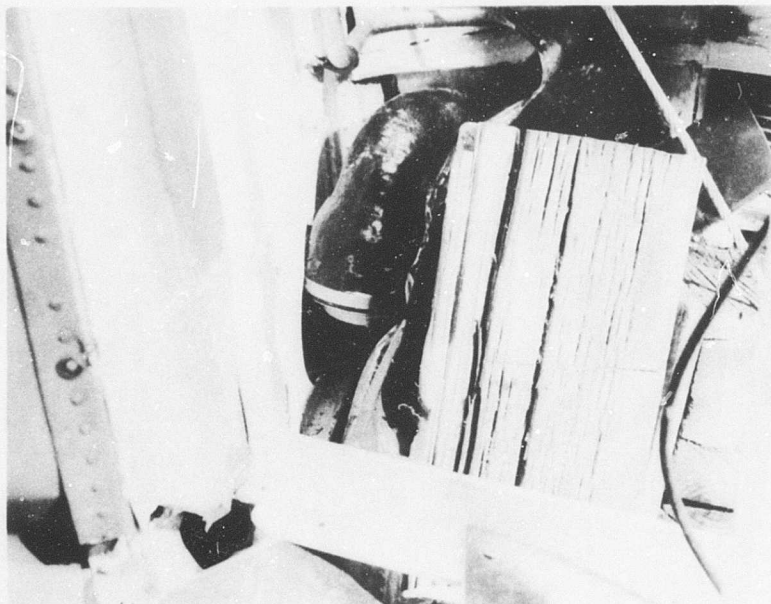

Figure 110. Aft Crossover Assembly Separation From the Right Cell.

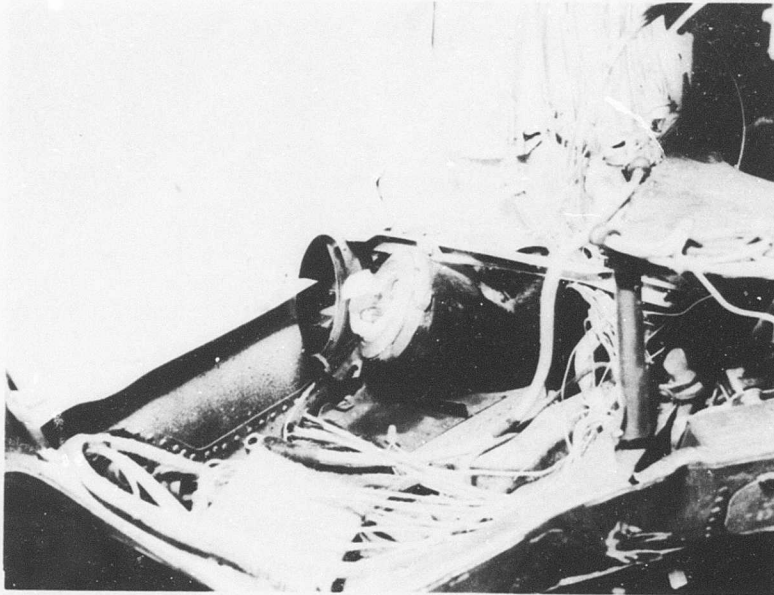

Figure 111. Aft Crossover Assembly Separation  
From the Left Cell.

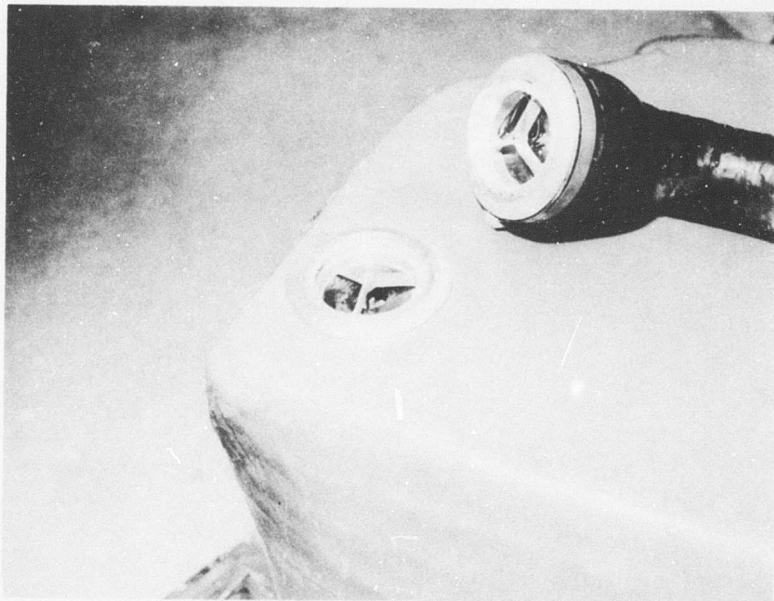

Figure 112. Breakaway Interconnect Separation -  
Right Side.

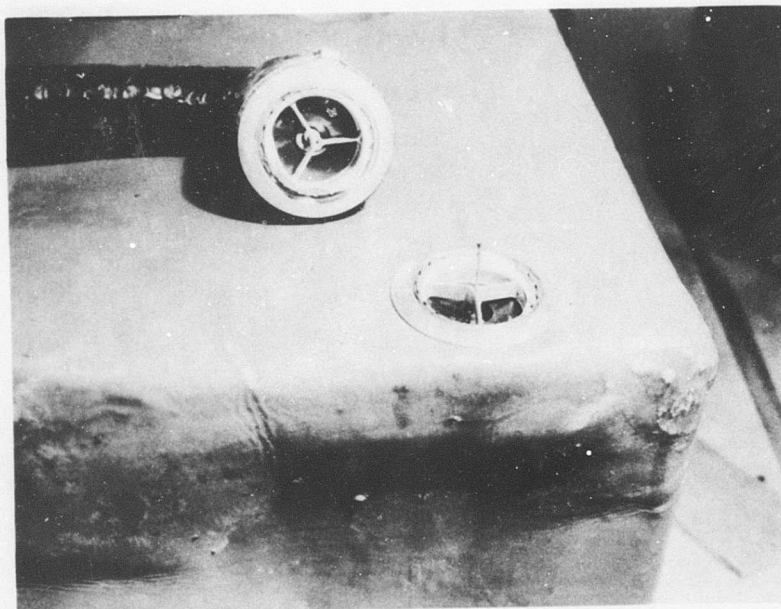

Figure 113. Breakaway Interconnect Separation - Left Side.

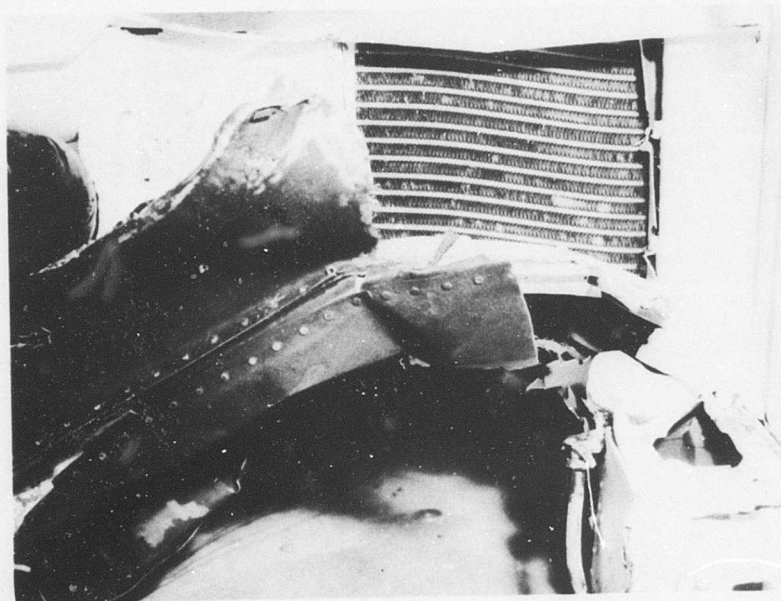

Figure 114. Posttest Front View of Oil Cooler.

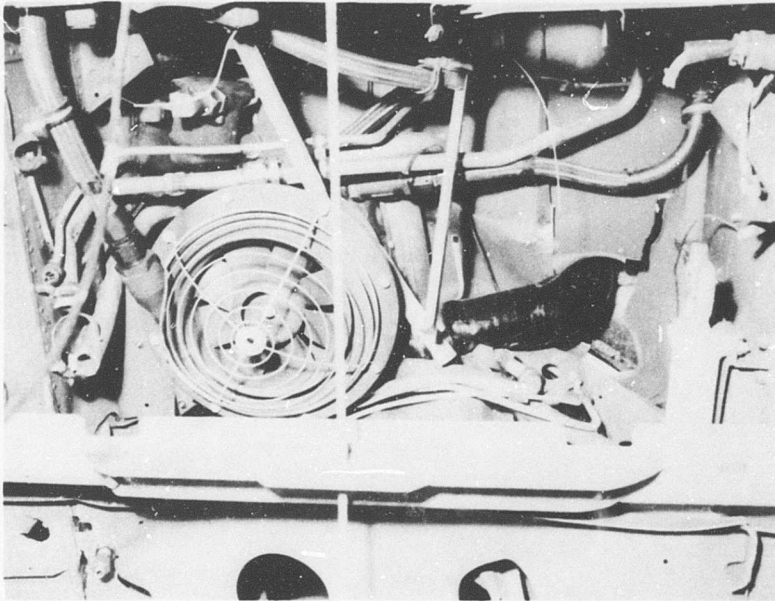

Figure 115. Posttest Rear View of Oil Cooler.

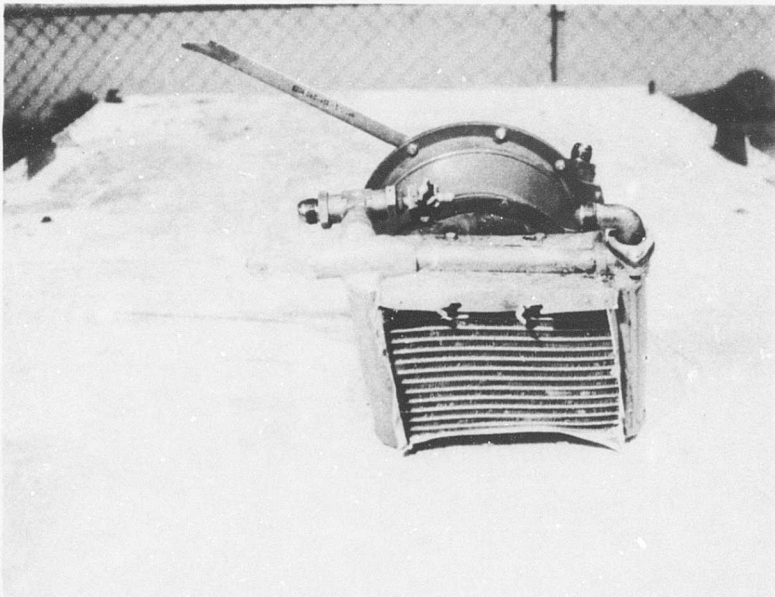

Figure 116. Oil Cooler After Removal From Test Section.

The cooler-to-engine flexible line separated at the rigid triggering valve mount in the service deck. This separation was caused by the weight of the flex line and valve beneath the deck mounting.

#### DISCUSSION

This vertical drop test was considered to be a success. Every component that was not called upon to function during the full-scale crash was made to function during this test. All components functioned as designed except the boost pump area. The fact that the pump mounting diaphragm pulled out of the tank by shearing the tank wall at the bolt holes clearly indicates the necessity of using the 100-percent retention concept, such as the wedge-lock. The displaced O-ring in the breakaway interconnect was the result of a slight design error and has since been corrected.

UNCLASSIFIED

Security Classification

DOCUMENT CONTROL DATA - R & D		
<i>(Security classification of title, body of abstract and indexing annotation must be entered when the overall report is classified)</i>		
1. ORIGINATING ACTIVITY (Corporate author) Dynamic Science (The AvSER Facility) A Division of Marshall Industries Phoenix, Arizona		2a. REPORT SECURITY CLASSIFICATION Unclassified
		2b. GROUP
3. REPORT TITLE DEVELOPMENT OF A CRASH-RESISTANT FLAMMABLE FLUIDS SYSTEM FOR THE UH-1A HELICOPTER		
4. DESCRIPTIVE NOTES (Type of report and inclusive dates) Technical Report		
5. AUTHOR(S) (First name, middle initial, last name) S. Harry Robertson		
6. REPORT DATE January 1969	7a. TOTAL NO. OF PAGES 163	7b. NO. OF REFS 3
8a. CONTRACT OR GRANT NO DAAJ02-67-C-0004	9a. ORIGINATOR'S REPORT NUMBER(S) USAAVLABS Technical Report 68-82	
b. PROJECT NO 1F162203A529	9b. OTHER REPORT NO(S) (Any other numbers that may be assigned this report) Dynamic Science 68-6	
10. DISTRIBUTION STATEMENT This report has been approved for public release and sale; its distribution is unlimited.		
11. SUPPLEMENTARY NOTES	12. SPONSORING MILITARY ACTIVITY US Army Aviation Materiel Laboratories Fort Eustis, Virginia	
13. ABSTRACT A crash test of a UH-1A helicopter was conducted to determine the effectiveness of a complete crash-resistant fuel, oil, and electrical system under severe accident conditions. The individual systems in the aircraft were developed over the past several years and had been tested individually in previous tests. This was the first test of a complete system.  The system included: (1) special crash-resistant fuel and oil tanks, (2) flexible fuel and oil lines that replaced many rigid lines, and (3) self-sealing breakaway valves and fluid-line disconnects at strategic locations.  The aircraft was flown by remote control during the crash test, in which all fuel tanks were filled with emulsified JP-4 and the engine was operating on emulsified JP-4. Manned test flights and calibration flights, operating on the emulsion, had been successfully accomplished prior to the test.  The test results indicated that a very high degree of crashworthiness had been achieved. No fuel or oil was spilled from any of the systems, even though many of them were displaced considerable distances. All of the crash-resistant systems that were called upon to function did so. Many others, not called upon, remained intact and appeared to be in operational condition. All of the fuel tanks and self-sealing valves were salvaged for future tests, even though the crash test was extremely severe.		

DD FORM 1 NOV 65 1473

UNCLASSIFIED

Security Classification

14 KEY WORDS	LINK A		LINK B		LINK C	
	ROLE	WT	ROLE	WT	ROLE	WT
Full-Scale Crast Test of UH-1A Helicopter Crash-Resistant Flammable Fluids System Development Operational Test of Emulsified Fuel						