

TR 1242
31 JANUARY 1969



TEST AND EVALUATION REPORT

DTIC 6890

EXPLORATORY ENVIRONMENTAL EVALUATION OF SOLDERLESS WRAPPED CONNECTIONS

A Report
Sponsored By Strategic
Systems Project Office
(SP23)

DDC
RECEIVED
JUN 25 1969
C

THIS DOCUMENT HAS BEEN APPROVED FOR PUBLIC
RELEASE AND SALE; ITS DISTRIBUTION IS UNLIMITED



INDIANAPOLIS, INDIANA 46218

COLOR ILLUSTRATIONS REPRODUCED
IN BLACK AND WHITE

Reproduced by the
CLEARINGHOUSE
for Federal Scientific & Technical
Information Springfield, Va. 22151

**Best
Available
Copy**

NAVAL AVIONICS FACILITY
INDIANAPOLIS, INDIANA

TECHNICAL REPORT

TECHNICAL EVALUATION DEPARTMENT

REPORT NUMBER TR-1242

31 January 1969

Exploratory Environmental Evaluation of Solderless
Wrapped Connections

T&E Task Assignment 67-2-8ER

Prepared by:

Approved by:

for E. W. Baird
O. E. Davis
Project Engineer

R. E. Mogle
R. E. Mogle, Chief
Product Evaluation Branch

Reviewed by:

Released by:

T. Smith
T. Smith
Project Supervisor

Arthur T. Updike
Arthur T. Updike, Director
Technical Evaluation Department

THIS DOCUMENT HAS BEEN APPROVED
FOR PUBLIC RELEASE AND SALE;
ITS DISTRIBUTION IS UNLIMITED.

PREFACE

Due to the ever increasing demand for high density point-to-point wiring techniques devoid of the many problems presently associated with soldered connections, the solderless wrapped connection (or wire wrap connection) is finding extensive use in both commercial and military electrical and electronic equipments. Wire wrapping is a technique for electrically and mechanically connecting a solid conductor to a terminal by wrapping a specified number of turns of wire, under tension, around a terminal having two or more sharp edges. The increasing use of the solderless wrapped connection as a wiring technique is accompanied by an increasing need for a comprehensive evaluation of the wrapped connection to determine its performance capabilities under a wide spectrum of environmental states, including those encountered under both ground and aerospace conditions.

As a step in fulfilling this need, the Product Evaluation Branch of Naval Avionics Facility, Indianapolis (NAFI), Indiana conducted an Exploratory Environmental Evaluation Program designed to establish environmental capabilities of wire wrap connections and to provide designers and users with some guidelines for their application in military systems. Although basic test procedures and environmental limits were developed around existing military specifications, the severity of these tests, both in duration and environmental extremes, was extended well beyond the requirements of these specifications. This was done in an effort to explore wire wrap characteristics under conditions far more extreme than those presently specified for wrapped connections and to possibly establish ultimate capabilities.

The Evaluation Program, performed with the technical assistance of NAFI Engineering Division (920) for the Strategic Systems Project Office (SP-23), was accomplished under Job Order F553. This report documents the results obtained during the test period as well as the conclusions and recommendations formed from these test results.

ABSTRACT

With the enormous number of possible combinations of wire and terminal materials, it was necessary to limit the types of wire, wrapposts, and connections tested to those expected by military-oriented designers to find the most extensive use in military equipments. As a result, test samples consisted of virgin, disturbed, and rewrapped connections formed from various combinations of the following types of wire and terminals (wrapposts).

NAFI TR-1242

- #26 AWG, Polysulfone-insulated, oxygen free high conductivity (OFHC) copper wire
- #30 AWG, Polysulfone-insulated and Durad "T" - insulated OFHC wire and Milene "B" - insulated Alloy 135 copper wire
- Half-hard brass wraposts, 0.025-in square x 0.50-in long
- Beryllium copper wraposts. 0.025-in square x 0.50-in long and 0.025-in square x 0.75-in long

All sample connections utilized in the evaluation were hand wrapped (as opposed to machine wrapping) by the NAFI Models Fabrication Branch (032.2) in accordance with the procedures outlined in NAVORD WS-6119. The mechanical and electrical performance tests conducted on the wrapped connections during the course of the evaluation consisted of: Embrittlement, Strip Force, Gas Tight Area, Wrapper Resistance, and Millivolt Drop. The performance requirements and test procedures employed were also those of WS-6119.

The Exploratory Environmental Tests were developed using Specification MIL-STD-810A and Standard Hardware (SHF) Specification NAVWEPS OD 30355 as guidelines. The tests included several temperature exposures, Thermal Shock, Sinusoidal Vibration, and Random Vibration Tests.

The Exploratory Environmental Evaluation Program disclosed several environment-related characteristics of wrapped connections, inadequacies in present military wire wrap specifications; and most importantly, demonstrated the solderless wrap to be a stable, reliable connection capable of withstanding environmental extremes well in excess of those required for most present military system applications.

Although this evaluation was concentrated primarily on investigating the wrapped connections per se, additional information relative to wire, wraposts, and vibration mounting configurations utilized was obtained as a by-product of the tests. Since this information is felt to be significant, it has also been included in this report.

TABLE OF CONTENTS

APPROVALS.	Title page
PREFACE.	iii
ABSTRACT	iii
I. CONCLUSIONS.	1
II. RECOMMENDATIONS.	5
III. BACKGROUND INFORMATION	7
A. DESCRIPTION OF CONNECTION TESTED	7
B. DESCRIPTION OF PERFORMANCE TESTS	9
C. TEST EQUIPMENT	10
IV. DESCRIPTION AND DISCUSSION OF TESTS.	10
A. PERFORMANCE UNDER LABORATORY CONDITIONS.	10
1. Visual Examination	10
2. Preliminary Tests.	10
a. Procedure.	10
b. Results.	12
(1) Strip Force.	12
(2) Wrapper Resistance	12
(3) Gas Tight Area	13
(4) Embrittlement.	13
B. PERFORMANCE TEST UNDER ENVIRONMENTAL CONDITIONS.	15
1. Temperature.	15
a. 105°C.	15
b. 150°C.	17
c. 200°C (Beryllium Copper Wraposts	20
d. 200°C (Half-Hard Brass Wraposts)	24
e. 200°C (Nitrogen Atmosphere	28
f. Analysis of Temperature Test Results	29
2. Thermal Shock.	32
3. Vibration.	33
a. Initial Vibration Test	33
b. Second Vibration Test.	40
4. Salt Spray	44
5. Remarks.	50

NAFI TR-1242

TABLE OF CONTENTS (Cont'd.)

APPENDICES

A. PHOTOGRAPHS	A.1
B. ILLUSTRATIONS	B.1
C. GRAPHS OF TEMPERATURE - STRIP FORCE CHARACTERISTICS . . .	C.1



I. CONCLUSIONS

A. Virgin and rewrapped connections of #26 and #30 AWG OFHC copper wire wrapped on beryllium copper or half-hard brass wraposts¹ complied with the wrapper resistance, strip force, embrittlement, and gas tight area requirements of Specification WS-6119 following sustained (120 hours or longer) temperature exposures to 200°C.

B. Virgin and rewrapped connections of #30 AWG Alloy 135 wire, wrapped on beryllium copper wraposts, comply with the strip force, embrittlement, and gas tight area requirements of Specification WS-6119 at temperatures up to and including 200°C.

C. In general, the strip force of all types of wraps tested increases when the wraps are subjected to sustained temperature exposures of 105°C or greater due to the formation of a diffusion weld between wire and wrapost. The degree of increase is a function of exposure time and temperature as shown in Graphs 1 through 9 of Appendix C.

D. Disturbed connections (see definition, paragraph III.A.2.b, page 7) of #26 and #30 AWG OFHC copper wire wrapped on beryllium copper or half-hard brass wraposts:

1. Comply with the wrapper resistance and embrittlement requirements of Specification WS-6119 when exposed to temperatures up to and including 200°C

2. Comply with the gas tight area requirements of Specification WS-6119 through temperature exposures to 150°C

3. Demonstrate marginal compliance with the gas tight area requirements of Specification WS-6119 after extended exposure (15 days) to a temperature of 200°C

4. Fail to comply with minimum strip force requirements prior to temperature exposure. The percentage of disturbed connections that fail to comply with the strip force requirements of Specification WS-6119 is reduced as a result of sustained exposure to elevated temperatures as shown in Table I below.

1. All wraposts utilized in this evaluation and hence referred to in this report were 0.025 x 0.025 inch in cross sectional dimensions.

TABLE I

Disturbed-Wrap Strip Force Failures

AWG Wire Size	Wrapost Material	Temper- ature in °C	Percentage of Strip Force Failures				
			Pre- Temp	After 1 day	After 5 days	After 10 days	After 15 days
#30	Beryllium Copper	150	95%	80%	80%	70%	70%
#30	Beryllium Copper	200	85%	40%	10%	10%	10%
#30	Half-Hard Brass	200	100%	90%	30%	10%	10%
#26	Beryllium Copper	150	100%	70%	40%	20%	20%
#26	Beryllium Copper	200	70%	0%	0%	0%	0%
#26	Half-Hard Brass	200	100%	50%	20%	0%	0%

E. Oxidation, resulting from exposure to extreme temperatures, does not appear to affect the electrical or mechanical characteristics of wraps formed with beryllium copper wrapposts and OFHC wire. Wrapped connections exposed to Temperature Tests in a nitrogen atmosphere (and consequently unoxidized) demonstrated no significant variations in performance characteristics from the oxidized temperature-exposed wraps.

F. A connection which fails to comply with the mechanical strip force requirements of Specification WS-6119 may still be capable of complying with the electrical and gas tight area requirements of Specification WS-6119.

G. The following conclusions apply to the different types of wire insulation used during the temperature tests.

1. Milene B insulation is unsatisfactory for use at sustained temperatures of 105°C and greater (see paragraph IV.B.1.a.(2).(b).1, page 17).

2. Test results indicate that a sustained (120 hours) temperature of 105°C is not detrimental to polysulfone insulation and is probably a conservative exposure for the material. However, polysulfone proved to be unsatisfactory during extended exposure to a temperature of 200°C.

3. Durad T insulation is satisfactory for use at sustained temperatures of 200°C (see paragraph IV.B.1.c.(2).(a), page 22).

H. Both virgin and previously vibrated connections of #26 and #30 AWG OFHC copper wire wrapped on beryllium copper wraposts comply with the strip force, wrapper resistance, embrittlement, and gas tight area requirements of Specification WS-6119 after exposure to Thermal Shock Tests.

1. In general, strip force measurements of each type wrap increased during each cycle of thermal shock having temperature extremes of -65°C and 200°C.

2. No detectable damage to the polysulfone insulation on the #26 and #30 AWG wire was observed following Thermal Shock Tests.

J. The following conclusions are derived from Random and Sinusoidal Vibration Tests performed on wire wrap connections of polysulfone-insulated #26 and #30 AWG OFHC copper wire hand wrapped on 0.025-inch beryllium copper wraposts (1/2-in and 3/4-in) mounted in wire wrap connector plates. These conclusions concern vibration as it relates to the wraps, the wiring, the wraposts, and the mounting configuration of the connector plates.

1. Of the Vibration Tests performed, random vibration in the vertical plane proved to be the most severe in terms of general damage to the wire wrap assembly; e.g., all wrapost breakage observed during the tests occurred during random vibration in the vertical plane.

2. Mounting wire wrap connector plates with clamp-type brackets is unsatisfactory for the vibration levels discussed herein (refer to Photograph 9, Appendix A).

3. Random Vibration Tests (particularly in the vertical plane) indicate that mounting the connector plates with screws (Photograph 14, Appendix A) in lieu of the aforementioned clamp-type brackets:

a. Aids in preventing wire and wrapost breakage at random vibration levels of $0.4g^2/Hz$ and below

b. Reduces the possibility of fatigue-induced fractures in the connector plates.

4. Damping the 10-module connector plates with Type 3 module headers ("dummy" modules) eliminated wire and wrapost breakage at all levels of vibration.

NAFI TR-1242

5. Based on metallographic analysis by the NAFI Metallurgical Materials Branch (033.2), it is concluded that all wrapost breakage incurred during vibration testing can be attributed to metal fatigue.

6. Test results indicate that the vertical plane of vibration, whether sinusoidal or random, is the most likely to induce wire breakage. Of a total of 158 leads broken during the initial Sinusoidal and Random Vibration Tests (a second Vibration Test was eventually performed), 123 leads broke as a result of vibration in the vertical plane.

7. #30 AWG wire is more susceptible to vibration-induced breakage than is #26 wire. The initial Vibration Tests (Sinusoidal and Random) resulted in breakage of 104 #30 AWG leads as compared to 54 #26 leads.

8. For #30 leads, test results revealed no conspicuous relationship between lead length and lead breakage, except, of the three lead lengths tested (3, 4, and 9 inch), the 4-inch leads incurred the fewest failures.

9. The #26 AWG leads, however, did exhibit a definite wire length-wire breakage relationship. The 9-inch leads proved to be the most vulnerable to vibration followed by the 2-inch leads with the 4-inch leads being the least susceptible to vibration-induced breakage.

10. Wire breakage on the Z-2 and Z-3 wrapper levels occurs more frequently than breakage on the Z-1 level.

11. For the most part, breakage of #30 AWG wire was preceded by (and attributed to) loosening of the insulated turns about the wraposts during vibration in the vertical plane. However, in spite of the loosened insulated turns, no movement of the uninsulated portion of the wrapped joint occurred and electrical integrity of the "joint" was maintained.

12. No definite conclusions as to resonant modes of #26 or #30 AWG wire or 1/2-inch wraposts can be drawn. Each circuit configuration designed, mounted, and damped as it would be in normal system use, should be subjected to vibration exposures for individual results.

K. Electrical Tests performed during random vibration in the vertical plane revealed the following information:

1. No arcing occurs between adjacent wraposts having potential differences of up to 1000 volts d-c continuously applied during the course of the test.

2. Contact of adjacent wraposts during the vibration exposure is prevented by the presence of insulated portions of the wraps. Hence, production process control and inspection procedures for wire wrap should place even more emphasis on control of the insulated turns of the wrapped joint for aircraft and missile environment applications than was necessary for ship-board applications.

3. The mated contacts between the "dummy" type modules and the Type 2 assembly exhibited no discontinuities greater than 10 microseconds. Measurement of discontinuities less than 10 microseconds in magnitude (if any) could not be achieved.

L. The four-terminal method of wrapper resistance measurement required by paragraph 5.4 of Specification WS-6119, and described in paragraph III.B.4 of this report, is more time consuming than necessary for the quantity of process control information derived.

M. Five percent salt spray exposure, conducted in accordance with MIL-STD-801A Method 509, for a duration of 240 hours does not affect the electrical performance (wrapper resistance) of either #26 or #30 AWG OFHC wire wrapped connections.

1. Corrosion of wrapped connections during salt spray exposure (up to 240 hours duration), through severe in some instances, does not affect the electrical characteristics of the connections

2. Salt spray induced corrosion of rewrapped connections progresses more rapidly, and is generally more severe, than that of virgin connections

3. Salt spray induced corrosion of rewrapped connections does not appear to be related to any previous electrical tests that may have been performed on the connections.

N. The primary observation derived from the testing reported herein is that throughout the testing of several hundred wrapped connections there were no failures, either mechanical or electrical, of a wrapped joint per se irrespective of the applied environment or severity of the environmental stress.

II. RECOMMENDATIONS

A. In addition to demonstrating some of the environmental capabilities of solderless wrapped connections, this evaluation also exposed many unresolved questions regarding the behavior of solderless wrapped connections under certain environmental conditions. As a result, it is recommended that additional evaluation and/or research studies be performed on solderless wrapped connections to answer questions not resolved by this effort. It is suggested that in future evaluation programs, the following areas of concentration be considered:

1. Evaluation of wrapped connections utilizing different combinations of wire and wrapost materials than were used in this evaluation

2. Comprehensive study of the strip force requirements to determine to what extent they do or do not establish the quality (or mechanical soundness) of the wrapped connection

3. Additional Sinusoidal Vibration Tests with emphasis on the following facets:

NAFI TR-1242

a. Resonance vibration to determine resonant modes of wraposts and wire runs of varying lengths and AWG sizes

b. Possibility of adjacent wraposts touching during resonant vibration if the pertinent connections are wrapped as Class B (WS-6119) connections, i.e., without the 1/2 turn of insulated wire prescribed by Specification WS-6119 for Class A connections

c. Comparative response of damped (by modules) and undamped wire wrap assemblies to resonant vibration

d. Vibration-induced discontinuities in the module-to-wrap plate mated contacts

4. Additional exploratory Random Vibration Tests with specific attention given to those aspects listed under Item 3 above

5. Evaluation of wrapped connections under a combination of environmental conditions; e.g., a combined temperature-humidity vibration environment.

B. It is recommended that each wire wrap circuit assembly designed be individually vibration tested under appropriate service use conditions.

C. It is recommended that no disturbed connections be intentionally used in the fabrication of wire wrap circuitry for military electronic equipments. However, since test results have shown that while all disturbed wraps may not comply with the stringent specification requirements of WS-6119, they none-the-less provide an electrically and mechanically stable joint that may be acceptable for repair actions. Additional data must be developed to determine the integrity of disturbed wraps and hence more discretely define the risk associated with the use of disturbed wraps in either limited quantity or in high population density applications.

D. It is suggested that consideration be given to "potting" wire wrap assemblies required to meet the random and sinusoidal vibration conditions specified by MIL-STD-810A for air and ground launched missiles. Test results indicate that, if properly damped, wire wrap assemblies designed for use in ground, sea, and aircraft equipments, may not require "potting".

NOTE: The term "potting" as used herein does not necessarily refer to a complete encapsulation of the back panel wiring but rather to a variety of methods that might be adopted by the design activity to stabilize, and damp, motion of the wrapost pins and associated wiring to prevent flexure breakage of back panel wiring.

E. Finally, it is recommended that a simplified continuity, or contact resistance measurement, as described in paragraph IV.B.1.f.(4)(b), page 31 be adopted to replace the wrapper resistance measurement method of paragraph 5.4 of Specification WS-6119.

III. BACKGROUND INFORMATION

A. DESCRIPTION OF CONNECTIONS TESTED - Solderless wrapped connections are fabricated by wrapping a specified number of turns of solid wire, under tension, around a rectangular post having four sharp edges. The sharp edges of the wrapost produce gas tight, high pressure points resulting in indentations on either the wire or the wrapost or both. The resulting gas tight high pressure points provide electrical continuity and mechanical stability. The solderless wrapped connections covered by this report are hand wrapped connections of #26 and #30 AWG OFHC wire or Alloy 135 wire wrapped on 0.025-in square wraposts, the minimum number per connection being five and seven turns of bare wire, respectively, and 1/2 turn of insulated wire when insulated wire is specified.

1. Fabrication of Solderless Wrapped Connections - All solderless wrapped connections were wrapped in the clockwise direction in accordance with paragraphs 4.3.1 and 4.4 of Specification WS-6119 with a hand wrapping tool. The wrapped connections were fabricated by NAFI Models Fabrication Branch (032.2). In addition, all wrapped connections of the same gage wire for each individual test (such as 105°C, 200°C, etc.) were wrapped by the same person and the same hand wrapping tool; however, different persons and/or hand wrapping tools may have been used for the connections utilized in each separate test.

2. Types of Connections - The types of solderless wrapped connections to be discussed in this report are defined as follows:

a. Virgin Wrap - A virgin wrap is the initial solderless wrapped connection that is wrapped on a previously unused or "virgin" wrapost.

b. Disturbed Wrap - A disturbed wrap is a virgin wrap that has been mechanically displaced a distance of one wrapper level on the wrapost by applying a steady force around the diameter of the top wrap causing it to slide steadily and evenly down the wrapost.

c. Rewrapped Connection - A rewrapped connection is a solderless wrapped connection formed on that portion of a wrapost from which one or more previously made connections have been unwrapped.

3. Wire

a. Uninsulated and Polysulfone Insulated - The conductor of all uninsulated wire and polysulfone insulated wire was silver plated, solid conductor, copper wire. The copper of the conductor was annealed oxygen free high conductivity (OFHC) copper. The uninsulated wire used in this evaluation was polysulfone insulated wire with the polysulfone jacket removed. Two sizes of wire were utilized, #26 AWG and #30 AWG, both in accordance with BuWeps Drawing No. 66A5A58.

b. Milene B Insulated - The conductor of the Milene B insulated wire utilized in this report was solid and composed of cadmium-chromium-copper alloy (Alloy 135). The milene insulation is composed of Mylar-polyvinyl chloride laminated tape which is wrapped and fixed to form a continuous and impervious insulation. Only one size of Milene insulated wire was used, #30 AWG in accordance with BuWeps Drawing No. 66A5A59.

c. Durad T Insulated - The conductor of the Durad T insulated wire utilized in this report was silver plated, solid conductor, copper (OFHC) wire. The Durad T insulation is a high temperature (200°C) insulation and basically consists of a dip-coated polyimide (ML) jacket over Teflon. Only #30 AWG Durad T insulated wire was used. The Durad T insulated wire was acquired by NAFI for evaluation purposes and the Durad T insulation (not the OFHC copper wire) was not covered by a military specification.

4. Wrapposts

a. Beryllium Copper - The beryllium copper wrapposts were gold plated over silver plating over copper plating in accordance with BuWeps Drawing No. 2655895, Type II. With one exception, all beryllium copper wrapposts tested were 0.025 inch square and 0.50 inch long. Wrapposts, 0.75 inch in length, were used in one 10-module connector plate of one wire wrap vibration test assembly.

b. Half-Hard Brass - The half-hard brass wrapposts were gold plated over silver plating over copper plating in accordance with BuWeps Drawing No. 2655895, Type II. The dimensions of all half-hard brass wrapposts were 0.025 inch x 0.025 inch x 0.50 inch.

5. Insulators - The contact insulators used in the wire wrap connector plates were composed of nylon material in accordance with BuWeps Drawing No. 2655895.

6. Wire Wrap Connector Plates - The basic building block of the wire wrap assemblies described herein is the connector plate (Photograph 9, Appendix A). In system application, this plate provides the electrical interface between Type 3 modules and the Type 2 mounting structure as well as a means for interconnecting the Type 3 modules. The plates used for this evaluation were fabricated from 1100-H14 aluminum stock with beryllium copper (or half-hard brass) contacts held in place and insulated from the aluminum plate with individual nylon insulators. The contacts were placed on 0.100-inch centers in groups of 40 contacts (two rows of 20 contacts each). A 40-contact connector accepts one Type 3 module. Each connector plate discussed herein was of a single width, 10-connector (or module) configuration.

B. DESCRIPTIONS OF PERFORMANCE TESTS - With the exception of the Millivolt Drop Tests, the Electrical and Mechanical Performance Tests were conducted in accordance with the procedures delineated in Specification WS-6119. In addition, the performance criteria and limits of Specification WS-6119 were utilized. The Millivolt Drop Tests were performed for information purposes only. A description of each type of Performance Test is as follows:

1. Embrittlement Test - The Embrittlement Test is performed by unwrapping sample connections with a Gardner Denver (or equivalent) unwrapping tool. An unwrapping tool is placed over a wrapost with its leading edge engaged between the wrap end and the next wrap turn. The unwrapping tool is then rotated until all of the wire is transferred onto the tool. The unwrapping tool, with the loose helical coil of wire, is then removed from the wrapost. The insulated portion of the wire is held firmly while the unwrapping tool is rotated so as to unwind the wire from the tool. It is not necessary that the unwrapped wire be perfectly straight. Waves or permanent deformation are permissible. In an acceptable wrap, the wire will not break during the unwrap process.

2. Strip Force Test - Strip force measurements are performed by exerting a pull of uniform rate upon the mating end of a wrapost while the wrap is held by a slotted fixture as shown in Figure 1 of Appendix B. The strip force is the maximum force in pounds required to displace the entire wrap a distance of 1/16 to 1/8 inch along the wrapost. Specification WS-6119 requires the minimum strip force of #26 and #30 AWG wire wrapped connections to be 4 and 2 pounds, respectively.

3. Gas Tight Area Tests - Gas Tight Area Tests are performed by first exposing wrapped connections to aqua regia and ammonium sulfide fumes, and then unwrapping the connections with a tool which does not scratch the wrapost. The gas tight areas resulting from the pressure contact between the wire and wrapost appear in bright contrast with the blackened area. Specification WS-6119 requires that an acceptable solderless wrapped connection have a total gas tight area between the wrapost and wire equal to or greater than the area of the cross section of the wire used in making the connections.

4. Wrapper Resistance Tests - Wrapper resistance measurements are performed by measuring the millivolt drop between the wrapost and wrap with a specified current flowing through the connection (see Figure 2 of Appendix B). When measured as illustrated in Figure 2 of Appendix B at currents of 1.0 and 2.4 amperes for #30 and #26 AWG wire, respectively, the voltage drop across an acceptable wrapped connection should not exceed 4.0 millivolts.

5. Millivolt Drop Test - Millivolt drop measurements were made by measuring the millivolt drop across 12 wrapped connections in series while a current of 35 milliamperes was flowing through the circuit. The

¹Tool #505244 for 0.025 inch pins and tool #500130 for 0.045 inch pins.

tests were performed in an effort to determine if the millivolt drop of the series connection changed significantly during environmental conditions. Since the test was not performed in accordance with any specific military specification, no performance limits were established.

C. TEST EQUIPMENT

1. Engineering Evaluation Performance Tests on Solderless Wrapped Connections were conducted utilizing the test equipment listed in Table II.

TABLE II

Test Equipment

<u>Equipment Nomenclature</u>	<u>Manufacturer</u>	<u>Model</u>
Microvolt-Ammeter	Kintel	203A
DC Milliammeter	Weston	1
DC Ammeter	Weston	670
DC Milliammeter	General Instruments	500
Power Supply	Hewlett-Packard	721A
Power Supply	Sorenson	T60-5
Hi-Pot	Industrial Instruments	P-2
Mechanical Force Gage	Hunter Springs	D-50-T
Relay Contact Vibration Test Set	NAFI	SA-A-4581
10x-30x-60x Microscope	Bausch and Lomb	

2. The accuracy of the test equipment used during the testing of Solderless Wrapped Connections was verified periodically by NAFI Standards and Calibration Division (430).

IV. DESCRIPTION AND DISCUSSION OF TESTS

A. PERFORMANCE UNDER LABORATORY CONDITIONS

1. Visual Examination - All unmounted individual wrapped connections and wrapped connections on the vibration fixtures were visually examined to determine that the connections were wrapped in accordance with Specification WS-6119. All connections were in compliance with the requirements of paragraph 4.3.3.1 of Specification WS-6119 prior to testing.

2. Preliminary Tests

a. Procedure - Individually wrapped unmounted virgin, disturbed, and rewrapped connections of #26 and #30 AWG wire wrapped on 0.025 inch x 0.025 inch x 0.50 inch beryllium copper wraposts were subjected to the

Embrittlement, Strip Force, Gas Tight Area, and Wrapper Resistance Tests of Specification WS-6119. The preliminary test was a short-term test performed under room ambient conditions. The test was performed generally to determine if a change in embrittlement of the wire, wrapper resistance measurements, or wrap relaxation occurs with respect to time over a 10-day test period at normal ambient laboratory conditions. Initially, there was speculation that a trend of wrap relaxation, discernible by a decline in wrap strip force, would occur in accordance with findings from previous wire wrap studies conducted by Bell Laboratories.¹ The time and date of fabrication of each group of 10 individual wraps was recorded. The sample sizes and number of samples of each type wrap for both wire sizes were established and tests scheduled with respect to the time and date they were fabricated, as shown in Table III below. Embrittlement, Strip Force, and Wrapper Resistance Tests were performed on a sample of each type wrap for both wire sizes within one hour after their fabrication to establish average reference values for the remainder of the tests. Then, Embrittlement, Strip Force, and Wrapper Resistance Tests were performed on samples of each type wrap of #30 AWG wire (except those rewrapped 10 times) and the virgin and disturbed wraps of #26 AWG wire at 24-hour intervals from the time of fabrication of each sample for a total of 240 hours (10 days). The daily average results were then compared with the reference results. In addition, Gas Tight Area Tests were performed on a sample of each type wrap for both wire sizes 10 days after their fabrication to determine if the wraps complied with the Gas Tight Area requirements of Specification WS-6119.

TABLE III

Preliminary Test Samples Sizes

<u>AWG Wire Size</u>	<u>Type Wrap</u>	<u>Reference</u>	<u>Sample Size Daily</u>	<u>Gas Tight</u>
30	Virgin	30	10	10
30	Disturbed	10	5	10
30	Rewrapped 10 times	10	0	10
30	Rewrapped 25 times	25	5	10
26	Virgin	20	5	10
26	Disturbed	20	5	10
26	Rewrapped 10 times	10	0	10
26	Rewrapped 25 times	10	0	10

¹S. J. Elliott, "Evaluation of Solderless Wrapped Connections for Central Office Use," The Bell System Technical Journal Vol. 38, pp 1033-1060, July 1959.

Strip Force, Wrapper Resistance, Embrittlement, and Gas Tight Area Tests were performed as delineated in Section III.B, page 9, of this report.

b. Results

(1) Strip Force - The daily average measurements of the sample wraps of virgin, disturbed, and rewrapped connections of #26 and #30 AWG wire showed no obvious trends with respect to time. However, there was a wide degree of variation between measurements of the same type wrap which is attributed to variations in the diameter of the wire, number of turns of wire and/or insulation, variations in wrapost dimensions (however slight), placement of the wire in the hand wrapping tool, and the personnel using the hand wrapping tool. See Table IV for strip force results. In addition, Graphs 1 and 2 of Appendix C depict the random variations in the daily average measurements.

Most strip force measurements of disturbed wraps of #26 and #30 AWG wire failed to comply with the minimum requirements of Specification WS-6119. Strip force measurements for disturbed wraps of #30 AWG wire varied between 0.2 to 2.6 pounds and the average measurement was 1.18 pounds (minimum limit: 2 pounds). Strip force measurements for disturbed wraps of #26 AWG wire varied between 0.4 to 6.5 pounds and the average measurement was 2.39 pounds (minimum limit: 4 pounds).

All strip force measurements of virgin and rewrapped connections of #26 and #30 AWG wire were in compliance with the requirements of Specification WS-6119. See Table IV for the daily average strip force measurements.

(2) Wrapper Resistance - Daily average wrapper resistance values indicated a decreasing resistance trend with respect to time. The apparent trend, however, is considered to be coincidental and not due to inherent properties of the wrap because:

(a) No similar trend was observed for disturbed and rewrapped connections of #30 AWG wire

(b) No similar trend was observed for virgin, disturbed, and rewrapped connections of #26 AWG wire.

For all types except virgin wraps of #30 AWG wire, a wide degree of variation among daily average measurements was observed. In addition, for all type wraps including virgin wraps of #30 wire, a wide degree of variation was observed among measurements of individual wraps of the same sample. The variations are attributed to inadequacies in that method of testing delineated in Specification WS-6119 and in random variations of individual wraps. Due to the small size wire used in fabricating the connections, the large amount of current flowing through the connection, and the small amount of voltage being measured, a minute movement of the

voltmeter probe or a small change in pressure applied to the wrap with the voltmeter probe can cause wide variations in the measurements. Thus, repeatability of the measurements by the same person or different persons is unlikely.

All wraps tested during the preliminary test period were in compliance with the wrapper resistance requirements of Specification WS-6119. The average wrapper resistance measurements of the disturbed wraps of both #26 and #30 AWG wire increased 5 percent to 100 percent over the wrapper resistance of the wrap prior to being disturbed; however, the maximum wrapper resistance measurements indicate a wrap may fail to meet established mechanical requirements and yet pass the electrical requirements of WS-6119. See Table V for daily average wrapper resistance measurements.

(3) Gas Tight Area - Ten wraps of each type wrap and each wire size were subjected to the Gas Tight Area Test described in paragraph III.B.3. Following exposure to the gaseous atmosphere, all wraps including disturbed wraps complied with the wrapper resistance and gas tight area requirements of Specification WS-6119. Thus, additional verification that a wrap which does not meet minimum strip force requirements (such as disturbed wraps) may exhibit satisfactory electrical characteristics.

(4) Embrittlement - No wire breakage was observed when 10 connections of each type wrap and each wire size were subjected to the unwrapping procedure delineated in paragraph III.B.1, page 9, of this report.

TABLE IV
Strip Force Measurements During Preliminary Tests

AWG Wire Size	Type Wrap	Ref	Average Strip Force Per Sample Size (LBS)										Average Daily Strip Force Measurement	Minimum Strip Force Measurement	Maximum Strip Force Measurement
			1	2	3	4	5	6	7	8	9	10			
#30	Virgin	8.4	8.6	8.3	7.6	9.1	8.1	8.6	8.3	8.3	8.5	8.4	8.4	5.0	12.4
#30	Disturbed	1.1*	1.04*	1.56*	0.99*	1.65*	1.2*	0.94*	0.52*	1.22*	1.46*	1.18*	0.2*	2.6	
#30	Rewrapped 10 times	2.5	-	-	-	-	-	-	-	-	-	8.5	7.5	10.3	
#30	Rewrapped 25 times	7.4	8.42	8.14	6.98	8.36	5.78	7.12	6.84	6.54	9.56	7.04	5.1	10.0	
#26	Virgin	14.6	13.2	15.1	15.4	12.5	14.9	13.7	13.8	13.2	15.4	14.1	11.2	21.0	
#26	Disturbed	2.85*	2.52*	2.3*	1.76*	2.28*	2.52*	1.76*	1.56*	4.82*	1.56*	2.42*	0.4	6.5	
#26	Rewrapped 10 times	13.6	-	-	-	-	-	-	-	-	-	13.6	11.5	15.7	
#26	Rewrapped 25 times	14.3	-	-	-	-	-	-	-	-	-	14.3	11.6	16.5	

Legend:

* - Out-of-Tolerance - Minimum limits of WS-6119 is 2.0 lbs. for #30 AWG wire and 4.0 lbs. for #26 AWG wire.
 - - Not tested

TABLE V
Wrapper Resistance During Preliminary Tests

AWG Wire Size	Type Wrap	Ref	Average Wrapper Resistance Per Sample Size (MV)										Average Daily Measurement	Minimum Measurement	Maximum Measurement
			1	2	3	4	5	6	7	8	9	10			
#30	Virgin	.54	.56	.45	.50	.51	.54	.39	.41	.43	.38	.47	.23	1.4	
#30	Undisturbed	.60	.59	.57	.63	.56	.55	.51	.62	.60	.63	.58	.40	.73	
#30	Disturbed	.90	.75	.57	.74	.74	.68	.63	.69	.72	.64	.71	.44	1.2	
#30	Rewrapped 10 times	.54	-	-	-	-	-	-	-	-	-	.54	.45	.70	
#30	Rewrapped 25 times	.61	.57	.37	.47	.38	.58	.35	.50	.53	.59	.49	.15	.80	
#26	Virgin	.60	.38	.50	.41	.38	.50	.46	.47	.49	.52	.48	.29	.84	
#26	Undisturbed	.58	.37	.52	.33	.38	.51	.50	.42	.43	.57	.48	.20	.88	
#26	Disturbed	.82	.74	.64	.61	.74	.67	.60	.76	.64	.67	.68	.36	1.2	
#26	Rewrapped 10 times	.61	-	-	-	-	-	-	-	-	-	.61	.36	.82	
#26	Rewrapped 25 times	.42	-	-	-	-	-	-	-	-	-	.42	.34	.88	

Legend:

- - Not tested

B. PERFORMANCE TESTS UNDER ENVIRONMENTAL CONDITIONS

1. Temperature Temperature Tests at 105°C and 150°C and three Temperature Tests at 200°C were performed on various types of individual wrapped connections and wraposts. The procedures, descriptions, and results of each test are as follows:

a. 105°C

(1) Procedure - In an effort to determine the effects of sustained elevated temperature on the characteristics of solderless wrapped connections and wire insulations, various samples of these connections were subjected to a 5-day, 105°C temperature exposure. The test sample consisted of: (a) individual virgin and rewrapped connections of #26 and #30 AWG, polysulfone insulated, OFHC wire wrapped on beryllium copper wraposts, and (b) three series circuits. The circuits, containing 12 series wraps each, were constructed on three individual 40-pin connector plates and were included for Millivolt Drop Tests during the 5-day exposure. They were comprised as follows:

Circuit No. 1 - #26 AWG wire with polysulfone insulation

Circuit No. 2 - #30 AWG wire with polysulfone insulation

Circuit No. 3 - #30 AWG wire with Milene B insulation

All connections were formed on 0.025-inch square beryllium copper wraposts which were mounted in nylon inserts on the 40-pin connector plates. Although the test temperature of 105°C exceeded the 85°C rated temperature of the Milene B insulation (BuWeps Drawing No. 66A5A59), there was speculation that the insulation could be used at higher temperatures. Polysulfone insulation is rated above the test temperature of 105°C (BuWeps Drawing No. 66A5A58).

Embrittlement and Strip Force Tests were performed on samples of the individual wrapped connections prior to temperature exposure and repeated on samples removed periodically from the temperature chamber during the course of the test. Sample sizes for Embrittlement and Strip Force Tests were as follows:

(a) Ten virgin and 10 rewrapped connections (25 times) of each gage wire, tested at room temperature to establish reference measurements.

(b) A sample size of 10 virgin connections of each gage wire and a sample size of 5 rewrapped connections (25 times) of #30 AWG wire removed from the test chamber at 24-hour intervals and tested as above.

(c) A sample size of 10 rewrapped connections (25 times) of #26 AWG wire tested after 5 days of exposure.

(2) Results

(a) Strip Force - The daily average strip force measurements of virgin and rewrapped connections of #30 AWG wire indicated an increasing trend during the 5-day exposure period. However, daily averages varied from day to day, with some daily averages lower than the preceding days average. It is suspected that the small increasing trend of the strip force measurements was being masked by a wider degree of variation between strip force measurements of the daily samples. Daily average strip force values are as shown in Table VI below.

The virgin wraps of #26 AWG wire exhibited a significant increase in strip force during the first three days of exposure then stabilized at the third day level for the duration of the tests. The final average strip force measurements showed an increase of approximately 84 percent over the pretemperature values. The average strip measurements of 10 rewrapped connections of #26 AWG wire after a 5-day temperature exposure was approximately 40 percent higher than pretemperature values.

Graph No. 3 of Appendix C depicts the increasing strip force trend of the virgin #26 and #30 AWG connections.

TABLE VI

Average Strip Force During 105°C Test

AWG Wire Size	Type Wrap	Daily Average Strip Force in Lbs.						Percent Increase 5th day-	Individual Measurement During Temperature in Lbs.	
		Ref	1	2	3	4	5		Min.	Max.
#30	Virgin	10.0	10.6	9.8	11.4	10.9	12.6	26%	7.1	15.0
#30	Rewrapped 25 times	10.2	10.2	10.1	11.6	11.5	11.8	15.6%	8.3	12.6
#26	Virgin	13.3	16.7	21.5	24.4	24.0	24.5	84.2%	14.9	27.7
#26	Rewrapped 25 times	14.6	-	-	-	-	20.5	40.4%	14.6	26.2

Legend:
- Not tested

(b) Millivolt Drop - No detectable trends in millivolt drop values were observed during the 105°C Temperature Test. The voltage drop of the wire, even though the wire length was less than one inch between wraps, was far greater than the voltage drop of the wraps. Thus, the only useful information obtained is that the length of wire interconnecting wrapped connections will produce more circuit loss than the wrapped connections.

Following the 5-day temperature exposure, a visual examination of the test circuits revealed the following:

1. The Milene insulation showed definite signs of shrinkage, had become more brittle, and had peeled from the insulated wraps. Thus, Milene insulation would be undesirable at sustained temperatures of 105°C or greater.

2. The nylon inserts of the wire wrap test connector were discolored and became more brittle than inserts not exposed to 105°C.

3. No embrittlement, discoloration, or shrinkage of the polysulfone insulation was observed.

(c) Gas Tight Area - All wraps subjected to Gas Tight Area Tests following the 5-day temperature exposure complied with the requirements of Specification WS-6119.

(d) Embrittlement - No wire breakage was observed when samples of each type wrap were subjected to the unwrap procedures delineated in paragraph III.B.1, page 9, of this report.

b. 150°C

(1) Procedure - Individual virgin, disturbed, and rewrapped connections of #26 AWG bare wire and #30 AWG wire with Durad insulation wrapped on beryllium copper wrapposts were subjected to a 30-day, 150°C temperature exposure. The test was performed in an effort to determine the effect of an extended 150°C temperature exposure on the performance characteristics of the various type wraps. Sample sizes of each type wrap of #26 and #30 AWG wire were established for reference and daily measurements as shown in Table VII below.

TABLE VII

150°C Sample Sizes

Wire Size	Type Wrap	Sample Size Per Gage Wire		
		Reference	Daily	Gas Tight
#26 & #30	Virgin	30	10	10
#26 & #30	Disturbed	20	10	10
#26 & #30	Rewrapped 10 times	10	10	10
#26 & #30	Rewrapped 25 times	10	5	10

Embrittlement, Strip Force, and Wrapper Resistance Tests were performed as indicated in Table VIII. Gas Tight Area Tests were performed on 10 samples of each type wrap after completion of the 30-day temperature exposure.

TABLE VIII

Performance Test Schedule (150°C Test)

<u>Performance Test</u>	<u>Type Wrap</u>	<u>Wire Size</u>	<u>Days Tests Were Performed</u>
Strip Force & Embrittlement	Virgin	#26 & #30	Reference & daily for 30 days
	Disturbed	#26 & #30	Reference & every other day for 30 days
	Rewrapped 10 times	#26 & #30	Reference & 30th day
	Rewrapped 25 times	#26 & #30	Reference, 1st - 5th, 10th, 15th, 20th, & 30th days
Wrapper Resistance	Virgin	#30	Reference, 1st - 5th, 10th, 10th, 20th, & 30th days
	Disturbed	#30	Reference, 2nd, 4th, 10th, & 30th days
	Rewrapped 10 times	#30	Reference & 30th day
	Rewrapped 25 times	#30	Reference, 1st - 5th, 10th, 15th, & 30th days

(2) Results

(a) Strip Force - In general, a trend of increasing strip force values for all type wraps was observed, with the strip force of #26 AWG wraps increasing faster than #30 AWG wraps. The most significant increases in strip force measurements above the reference measurements were observed during the first four days of temperature exposure. After the fourth day, the strip force measurements of virgin wraps of both gages of wire continued to increase through the 15th day, but at a slower rate. The strip force measurements of rewrapped connections (25 times) of #26 AWG wire followed a similar trend; however, the strip force measurements of rewrapped connections (25 times) of #30 AWG wire appeared to reach a peak on the 5th day, then decreased approximately one pound and remained stable through the remainder of the test. Many strip force measurements

of disturbed wraps for each gage wire failed to meet the minimum strip force requirements of Specification WS-6119 following the temperature exposure; however, the daily average measurements tended to increase over the 30-day period with many daily averages being above the minimum strip force requirements of Specification WS-6119 (the minimum strip force requirements of Specification WS-6119 are 2.0 pounds and 4.0 pounds for #30 and #26 AWG wire, respectively). The average daily strip force measurements for the first five days and every fifth day thereafter are as shown in Table IX below. In addition, the daily average strip force measurements are presented in Graphs 4 and 5 of Appendix C.

TABLE IX

Average Strip Force (150°C Test)

AWG Wire Size	Type Wrap	Daily Average Strip Force in Pounds											Percent Increase Over 30 days	Individual Reading During Temp. in Lbs.	
		Ref.	1	2	3	4	5	10	15	20	25	30		Min.	Max.
#30	Virgin	4.8	6.7	7.3	7.7	9.8	9.6	9.1	10.1	10.9	10.3	9.8	104.1	3.2	14.7
#30	Disturbed	1.1	-	2.4	-	1.3	-	2.1	-	1.8	-	2.6	136.3	.20	5.0
#30	Rewrapped 10 times	6.2	-	-	-	-	-	-	-	-	-	8.6	38.7	6.8	11.6
#30	Rewrapped 25 times	5.7	8.5	8.3	8.2	9.4	9.4	8.6	8.3	8.6	-	8.6	50.8	6.4	10.8
#26	Virgin	8.0	14.0	15.6	15.3	15.4	17.1	17.2	17.5	21.4	18.4	18.7	133.7	12.2	26.6
#26	Disturbed	1.8	-	3.5	-	4.8	-	8.9	-	8.1	-	8.3	361	1.7	19.5
#26	Rewrapped 10 times	8.6	-	-	-	-	-	-	-	-	-	22.2	158	16.8	26.8
#26	Rewrapped 25 times	8.7	16.7	18.5	19.7	18.7	20.2	21.2	21.1	-	-	22.6	160	12.2	24.0

Legends:
- not tested

(b) Wrapper Resistance - All wrapper resistance measurements before and after temperature were within the maximum limits of Specification WS-6119 (4 mv maximum). Wide variations among measurements of the same type wrap and between the pretemperature and post-temperature measurements were observed; however, the variations were attributed to the inadequacies of the method of measurement (test method as specified in paragraph 5.4 of Specification WS-6119 and paragraph III.B.4, page 9, of this report) and random variations of individual wraps. Due to the size of wire used in fabricating the wrap, the amount of current flowing through the wrap, and the small amount of voltage being measured, a minute movement of the voltmeter probe can cause wide variations in measurements. Thus, repeatability of the measurements by the same person or different persons is unlikely.

TABLE X

Average Wrapper Resistance (150°C Test)

AWG Wire Size	Type Wrap	Remarks	Daily Average Wrapper Resistance in MV									
			Ref	1	2	3	4	5	10	15	20	30
#30	Virgin	Pre-Temp	.76	.70	.62	.65	.62	.70	.72	.70	-	.75
#30	Virgin	Post-Temp	-	.66	.64	.59	.61	.67	.74	.61	-	.85
#30	Disturbed	Pre-Temp	1.0	-	.95	-	.81	-	1.07	-	.98	.81
#30	Disturbed	Post-Temp	-	-	.87	-	.83	-	.91	-	1.04	.92
#30	Rewrapped 25 times	Pre-Temp	.73	.74	.66	.61	.68	.71	.63	.77	.67	.65
#30	Rewrapped 25 times	Post-Temp	-	.73	.70	.61	.67	.69	.65	.75	.65	.76

Legend: - not tested

(c) Gas Tight Area - All wraps subjected to Gas Tight Area Tests following the 30-day temperature exposure complied with the requirements of Specification WS-6119.

(d) Embrittlement - No wire breakage was observed when samples of each type wrap were subjected to the unwrap procedures delineated in paragraph III.B.1, page 9, of this report.

(e) Visual Examination - Slight discoloration of the silver plated OFHC wire was observed on all wraps. No deterioration of the Durad insulation on the #30 AWG wire was observed during the test period.

c. 200°C (Beryllium Copper Wrapposts)

(1) Procedure - Individual virgin, disturbed, and rewrapped connections of #26 and #30 AWG wire and virgin wraps of both wire gages (that had been previously subjected to the Vibration Test described in paragraph IV.B.3.a, page 33, of this report) were subjected to a 15-day 200°C Temperature Test. All connections were wrapped on beryllium copper wrapposts. Uninsulated wire was used to fabricate all connections except the disturbed wraps of #30 AWG wire and the previously vibrated wraps. Durad T insulated wire was used for the #30 AWG disturbed wraps and polysulfone-insulated wire was used for the #26 and #30 AWG vibrated wraps. The test was performed in an effort to determine what effect, if any, extended exposure to extreme temperature would have on the physical, mechanical, and electrical characteristics of various types of solderless wrapped connections. Sample sizes were established for reference and daily measurements as shown in Table XI below.

TABLE XI

200°C Sample Sizes

AWG Wire Size	Type Wrap	Sample Size Per Gage Wire		Gas Tight
		Reference	Daily	
#26 & #30	Virgin	20	10	10
#26 & #30	Disturbed	20	10	10
#26 & #30	Rewrapped 25 times	10	5	10
#26 & #30	Vibrated	30	10	10
#26 & #30	Rewrapped 10 times	-	-	10

Legend:
- not tested

Embrittlement, Strip Force, and Wrapper Resistance Tests were performed prior to, during, and after the exposure as shown in Table XII below. Gas Tight Area Tests were performed on samples of all type wraps after the 15-day temperature exposure.

TABLE XII

Performance Test Schedule (200°C)

Performance Tests	Type Wrap	Wire Size	Frequency of Tests
Strip Force a n d	Virgin	#26 & #30	reference and daily for 15 days
	Disturbed	#26 & #30	reference, 1st through 5th, 10th and 15th days
	Rewrapped 25 times	#26 & #30	reference, 1st through 5th, and 15th days
Embrittlement	Vibrated	#26 & #30	reference, 1st through 5th, and 15th days
Wrapper Resistance	Disturbed	#30	reference, 1st, 5th, 10th, and 15th days

(2) Results

(a) Visual Examination - A visual examination of the sample revealed that oxidation of the silver plating of the OFHC copper wire started during the first day of temperature exposure and increased progressively through the 15th day. Photograph 1 of Appendix A depicts the discoloration (oxidation) of the silver plating at various time intervals of the test. In addition, slight discoloration of the gold plated beryllium copper wrapposts was observed.

The 200°C temperature exposure was in excess of the maximum rated sustained temperature of polysulfone insulation; however, no visible damage was incurred (other than slight discoloration) during the first three days of temperature exposure. After 5 days, the discoloration had increased and the polysulfone insulation appeared to be becoming brittle. After 15 days of exposure to 200°C temperatures, the polysulfone insulation was brittle and badly discolored. Bending of the lead would cause cracks in the insulation.

The 200°C temperature exposure had no detectable adverse effects on the Durad T insulation of the disturbed wraps of #30 AWG wire.

(b) Strip Force - In general, strip force data showed the strip force to behave at 200°C in about the same manner as at 150°C. Again, almost all of the reference period measurements were significantly below the subsequent strip force measurements indicating the effect of the temperature. However, daily average measurements show that the greatest increase occurs during the first day of temperature exposure with #26 AWG wraps demonstrating the greater increase. The daily average strip force measurements of all type wraps are depicted in Graphs 6 and 7 of Appendix C and are tabulated in Table XIII below. The strip force measurements for virgin connections of #26 and #30 AWG wire and the rewrapped connections of #26 AWG wire reached a peak value on the second day instead of the fourth and fifth day as in the 150°C test. Following the second day, the average strip force of #30 AWG virgin connections varied no more than +2 to -1 pounds from the second day averages throughout the remainder of the test. However, the average strip force of #26 AWG virgin and rewrapped connections decreased 2 to 3 pounds from the second day values and remained fairly stable throughout the remainder of the test. The average strip force measurements of #30 AWG rewrapped connections showed a progressive increase throughout the test period.

The average strip force of the daily samples of #30 AWG disturbed connections showed a steady increase throughout the Temperature Test. All daily averages were greater than the 2 pound minimum requirement. The average strip force of the daily samples of #26 AWG disturbed connections peaked at 16.4 pounds on the third day and then decreased to

12.7 pounds on the fifteenth day. It should be noted that most strip force measurements of disturbed wraps of #26 and #30 AWG wire which have not been subjected to high temperature exposures fail to meet the minimum strip force requirements of Specification WS-6119; however, after two days of 200°C temperature exposure, all strip force measurements for #26 AWG disturbed wraps were greater than the specified minimum for #26 AWG wraps (4 pounds); and after four days, 90 percent of the #30 AWG wraps were above the specified minimum for #30 AWG wrap (2 pounds).

The daily average strip force of #30 AWG vibrated wraps showed a much greater percentage of increase (over the 15-day test period) than that of the uninsulated #30 AWG virgin wraps but followed a similar pattern (see Table XIII). Initially, it was concluded that the polysulfone insulation of the previously vibrated wraps was responsible for the greater increase in strip force; however, the #26 AWG wraps did not behave in a similar manner in that the increase in average strip force of the uninsulated virgin wraps was 20 percent greater than that of the insulated, vibrated wraps.

TABLE XIII

AWG Wire Size	Type Wrap	Ref	Average Strip Force Measurements in lbs.										Percent Increase on 15th day
			1	2	3	4	5	7	10	13	15		
#30	Virgin	6.1	9.1	11.4	10.3	11.6	12.2	11.6	13.1	10.7	11.9	95	
#30	Disturbed	1.1	3.3	3.4	4.1	3.7	3.9	-	4.9	-	5.7	418	
#30	Rewrapped 25 times	4.4	6.4	6.3	6.3	7.0	7.8	-	8.4	-	8.7	98	
#30	Vibrated	8.8	17.0	22.2	19.3	25.5	24.7	-	-	-	21.3	142	
#26	Virgin	11.6	24.0	25.3	21.8	23.3	21.6	22.2	20.6	20.5	22.3	92	
#26	Disturbed	3.3	11.5	14.7	16.4	14.6	14.9	-	12.0	-	12.7	285	
#26	Rewrapped 25 times	9.4	20.4	21.5	18.1	18.5	18.7	-	18.6	-	18.7	99	
#26	Vibrated	11.7	22.3	17.2	18.9	17.6	19.4	-	-	-	20.1	72	

Legend:
- not tested

(c) Wrapper Resistance - No significant changes were observed between the reference and post-temperature wrapper resistance measurements on #30 AWG disturbed wraps. The reference, first, fifth, tenth, and fifteenth day averages were 0.54 mv., 0.60 mv., 0.64 mv., and 0.59 mv., respectively. As depicted by Table XII, wrapper resistance measurements were not performed on wraps other than the #30 AWG disturbed wraps.

(d) Gas Tight Area - All wraps subjected to Gas Tight Area Tests following the 15-day temperature exposure were in compliance with the requirements of Specification WS-6119. However, the gas tight areas under the disturbed wraps of #26 and #30 AWG wire were marginal. Photographs 2 and 3 of Appendix A depict the gas tight areas that were under the various types of wraps at room ambient and following the 200°C temperature exposure. Wraposts depicted in Photograph 2 were wrapped with #26 AWG wire and wraposts depicted in Photograph 3 were wrapped with #30 AWG wire.

(e) Embrittlement - No wire breakage resulted when samples of each type wrap were subjected to the unwrap procedures delineated in paragraph III.B.1 of this report during and following the 200°C temperature exposure. However, wraposts of those wraps which endured the entire test period (15 days) appeared contrastingly lighter in color on that portion of their surfaces which had been in contact with the wrapped wire. It was determined (metallurgically) that the silver plating of the wire had adhered to the wraposts indicating the formation of a bond between wire and wrapost. Photographs 4 and 5 of Appendix A depict this discoloration of wrapped area for wraposts wrapped with both #26 and #30 AWG wire. Unwrapped wraposts that were not subjected to high temperature exposure are also shown for comparison purposes. Photograph 4 and Photograph 5 depict unwrapped wraposts of #26 and #30 AWG wraps, respectively.

d. 200°C (Half-Hard Brass Wraposts)

(1) Procedure - Individually wrapped virgin, disturbed, and rewrapped connections of #26 and #30 AWG wire wrapped on half-hard brass wraposts were subjected to a 15-day 200°C Temperature Test. All #26 AWG connections were wrapped with uninsulated wire and all #30 AWG connections were wrapped with Durad T insulated wire (#26 AWG OFHC wire was not available with Durad T insulation). The tests were performed to: (a) determine the effect of sustained high temperature on connections wrapped on half-hard brass wraposts and (b) obtain data necessary to compare high temperature characteristics of half-hard brass wrapost connections and connections wrapped on beryllium copper wraposts. Sample sizes of each type wrap were established for reference and daily measurements as shown in Table XIV below.

TABLE XIV
 Samples Sizes
 (Half-Hard Brass Wraposts at 200°C)

AWG Wire Size	Type Wrap	Reference	Sample Size Per Gage Wire	
			Daily	Gas Tight
#26 & #30	Virgin	20	10	10
#26 & #30	Disturbed	20	10	10
#26 & #30	Rewrapped 25 times	10	5	10
#26 & #30	Rewrapped 10 times	-	-	10

Legend:
 - not tested

Embrittlement, Strip Force, and Wrapper Resistance Tests were performed as shown in Table XV below. Gas Tight Area Tests were performed on samples of all type wraps after the 15-day temperature exposure.

TABLE XV
 Performance Test Schedule
 (200°C Test on Half-Hard Brass Wraposts)

Performance Tests	Type Wrap	Wire Size	Frequency of Tests
Strip Force	Virgin	#26 & #30	reference and daily for 15 days
	Disturbed	#26 & #30	reference, 1st through 5th, 10th, and 15th days
Embrittlement	Rewrapped 25 times	#26 & #30	reference, 1st through 5th, 10th, and 15th days
	Virgin	#30	reference, 1st, 5th, 10th, and 15th days
Wrapper Resistance	Disturbed	#30	reference, 1st, 5th, 10th, and 15th days
	Rewrapped 25 times	#30	reference, 1st, 5th, 10th, and 15th days

(2) Results

(a) Visual Examination - A visual examination of the sample wraps revealed that oxidation of the silver plating of the OFHC copper wire occurred as in the previous 200°C Test. Also, slight discoloration of the half-hard brass wrapposts was observed.

(b) Strip Force - In general, the average strip force of connections on half-hard brass wrapposts increase when exposed to 200°C temperature. The results of the strip force measurements show that:

1. All average reference strip force measurements were significantly lower than average post-temperature measurements.

2. #26 AWG wraps show the greatest increase in strip force when exposed to 200°C.

3. In addition, the largest increase in strip force occurs during the first day of the temperature exposure.

4. During the first five days of temperature exposure many (up to 40 percent) out-of-tolerance strip force measurements for each gage wire were observed for disturbed wraps. On the tenth and twentieth day, 90 percent of the #30 AWG connections and 100 percent of the #26 AWG connections were above minimum requirements.

5. The average strip force measurements are as shown in Table XVI below. In addition, the average daily strip force measurements are presented visually in Graphs 8 and 9 of Appendix C.

TABLE XVI

Average Strip Force
(200°C Test on Half-Hard Brass Wraposts)

AWG Wire Size	Type Wrap	Ref	<u>1</u>	<u>2</u>	<u>3</u>	<u>4</u>	<u>5</u>	<u>7</u>	<u>10</u>	<u>13</u>	<u>15</u>	Percent Increase on 15th day
#30	Virgin	4.8	7.5	8.8	8.1	8.3	8.6	9.3	10.2	9.6	9.1	90
#30	Disturbed	1.1	1.1	2.0	2.6	2.7	2.9	-	2.8	-	3.3	200
#30	Rewrapped 25 times	4.7	3.7	5.5	6.0	5.3	5.6	-	6.0	-	5.2	11
#26	Virgin	7.5	16.6	17.3	16.0	14.5	17.4	16.4	14.3	14.1	14.2	89
#26	Disturbed	1.8	4.8	7.7	5.8	4.6	6.7	-	6.5	-	6.7	272
#26	Rewrapped 25 times	5.6	17.0	17.7	14.4	15.2	13.2	-	14.8	-	13.0	132

Legend:
- not tested

(c) Wrapper Resistance - Average wrapper resistance measurements showed a small increase of approximately 0.15 to 0.31 mv for all type wraps after the first day of temperature exposure. However, wrapper resistance measurements for the tenth and fifteenth days were lower than the first day measurements as shown in Table XVII.

TABLE XVII

Average Wrapper Resistance
(200°C Test on Half-Hard Brass Wraposts)

Wire Size	Type Wrap	Average Wrapper Resistance in mv				Total Test Average
		Ref	<u>1</u>	<u>10</u>	<u>15</u>	
#30	Virgin	0.69	0.84	0.60	0.52	0.65
#30	Disturbed	0.69	0.81	0.73	0.68	0.74
#30	Rewrapped 25 times	0.64	0.96	0.46	0.62	0.71

(d) Gas Tight Area - All wraps subjected to Gas Tight Area Tests following the 15-day temperature exposure were in compliance with the requirements of Specification WS-6119. However, the gas tight areas under the disturbed wraps of each gage wire were marginal. Photograph 6 of Appendix A depicts the gas tight area that was under the various types of #26 and #30 AWG wraps at room ambient and 200°C temperatures.

(e) Embrittlement - No wire breakage was observed when samples of each type wrap were subjected to the unwrap procedures delineated in paragraph III.B.1, page 9, of this report; however, following the 200°C temperature exposure, the area of the wraposts which were in contact with the wraps appeared lighter in color, indicating that again the silver plating of the wire had adhered to the wrapost. Photographs 7 and 8 of Appendix A depict the discoloration of the wrapped area for various type wraps of #26 and #30 AWG wire following 200°C temperature exposure. In addition, unwrapped wraposts of each type wrap that were not subjected to high temperature exposures are shown for comparison purposes. Photographs 7 and 8 depict unwrapped wraposts of #26 and #30 AWG wraps, respectively.

e. 200°C (Nitrogen Atmosphere)

(1) Procedure - It was suspected that oxidation of the silver plated wire utilized in fabricating the wrapped connections was the cause for the increased strip force measurements following high temperature exposures. Therefore, a 15-day Temperature Test at 200°C was performed on sample wraps in an inert (oxygen free) atmosphere. Nitrogen was the inert atmosphere used for this test.

Thirty virgin wraps of #30 AWG polysulfone insulated wire wrapped on beryllium copper wraposts were subjected to 200°C temperature in the nitrogen atmosphere for 15 days. Wrapper Resistance, Strip Force, and Embrittlement Tests were performed on a sample of 20 virgin wraps to establish reference measurements.

An additional 30 wraps were placed in a nitrogen atmosphere and subjected to a 200°C temperature exposure for 15 days. Strip Force and Wrapper Resistance Tests were performed on 20 of the wraps and Embrittlement and Gas Tight Area Tests were performed on the remaining 10 wraps after completion of the exposure.

(2) Results

(a) Visual Examination - Discoloration of the wraps was observed following the temperature exposure; however, it was yellow discoloration instead of the black discoloration observed during previous 200°C Temperature Tests in oxygen atmospheres. It is suspected that the discoloration was due to the polysulfone insulation since 200°C is above the maximum sustained temperature rating of polysulfone insulation. Definite signs of shrinkage of the polysulfone insulation was observed, but the insulation did not become brittle as in previous 200°C tests in a normal atmosphere.

(b) Strip Force - The average strip force of the 20 reference samples was 8.4 pounds. The 20 wrapped connections subjected to 15 days of temperature exposure had a post-temperature average strip

force of 12.4 pounds. Since these results were consistent with those of oxygen-atmosphere Temperature Tests, it was concluded that a mechanism other than oxidation was responsible for the temperature-induced increases in strip force values. An investigation in the form of a metallographic analysis was then performed. Results of this analysis are reported in paragraph IV.B.1.f below.

(c) Wrapper Resistance - The average wrapper resistance before and after temperature exposure of the 20 wraps was 0.59 mv and 0.62 mv, respectively.

(d) Gas Tight Area - The 10 wraps subjected to Gas Tight Area Tests following the 15-day temperature exposure were in compliance with the requirements of Specification WS-6119.

(e) Embrittlement - No wire breakage was observed when samples of each type wrap were subjected to the unwrap procedures delineated in paragraph III.B.1, page 9, of this report. Again, as in previous tests, there were indications that the silver plating of the wire adhered to the wraposts. These temperature-exposed wraposts along with unexposed wraposts (for comparison) are depicted in Photographs 7 and 8 of Appendix A.

f. Analysis of Temperature Test Results

(1) Strip Force - Strip force data obtained from temperature-exposed connections revealed a propensity for the strip force to increase when the wraps were aged at elevated temperatures; however, the data also indicate that the strip force for each type wrap tested reaches a peak value which may be two to three times the value of a similar but unexposed wrapped connection. The length of time required for each type wrap to increase to this peak value is related to both temperature level and exposure time. The higher the temperature, the less the time that is required for a wrap to reach its peak. A comparison of Graphs Numbers 1 through 9 (Appendix C) will illustrate this time-temperature relationship.

(2) Metallographic Analysis - Following the Temperature Tests, 12 virgin wraps were subjected to metallographic analysis by NAFI Metallurgical Materials Branch (B/033.2). The analysis was performed in an effort to determine the cause of increased strip force measurements after aging the connections at elevated temperatures. The sample of 12 wraps was comprised as follows:

(a) Four wraps that had not been exposed to elevated temperatures. Two of the wraps had been subjected to Strip Force Tests.

(b) Four wraps that had been exposed to 200°C for 15 days in normal (oxygen) atmosphere. Two of the wraps had been subjected to Strip Force Tests.

(c) Four wraps that had been exposed to 200°C for 15 days in a nitrogen atmosphere. Two of the wraps had been subjected to Strip Force Tests.

The results of the analysis were as follows:

1. Metallographic analysis of the sample wraps revealed that the pins were beryllium copper plated with copper, overplated with a heavy white metal plate of nickel, and topped with a thin gold plate. The #30 AWG copper wire was silver plated.

2. After aging the gold-nickel interface was much more diffuse than the discrete, well defined system before aging. Gold had diffused into the nickel. At the gold silver interface there was an appreciable amount of diffusion too, actually forming a small weld. Where the junction was broken by the test, the microstructure of the originally fayed surfaces showed damage to the plating, indicating that the new surfaces had fractured irregularly through the plating system as if breaking through a weld zone. Thus, the strengthening mechanism appears to be a diffusion weld formed during the aging at elevated temperature.

(3) Disturbed Wraps - Connections which have been moved (slid) one or more wrap levels (disturbed wraps) on beryllium copper or half-hard brass wrapposts fail to comply with the minimum strip force requirements of Specification WS-6119; however, according to the requirements of Specification WS-6119, the disturbed wraps form satisfactory electrical connections as shown by the results of the Wrapper Resistance and Gas Tight Area Tests performed on disturbed wraps. In addition, the mechanical strip force of disturbed wraps was increased to acceptable levels for:

(a) Ninety percent of the disturbed wraps of #30 AWG wire on both type wrapposts (beryllium copper and half-hard brass) after a 10-day 200°C temperature exposure

(b) Ninety percent of the disturbed wraps of #26 AWG wire on beryllium copper wrapposts after a 10-day 150°C temperature exposure

(c) One hundred percent of the disturbed wraps of #26 AWG wire on half-hard brass wrapposts after a 10-day 200°C temperature exposure

(d) One hundred percent of the disturbed wraps of #26 wire on beryllium copper wrapposts after a 2-day 200°C temperature exposure.

(4) Wrapper Resistance - No definite trends were indicated by the wrapper resistance data recorded during the Temperature Tests. All measurements performed in all Temperature Tests were in compliance with the requirements of Specification WS-6119. The maximum wrapper resistance measurement observed was 1.4 mv. The maximum wrapper resistance limit of Specification WS-6119 is 4 mv.

It should be mentioned that the present four-terminal method of wrapper resistance measurement, as required by WS-6119, provides greater precision than is required for production sample testing and hence is more time consuming than necessary for the amount of information derived relative to wrapper electrical quality. Personnel of the Naval Avionics Facility who have been associated with wire wrap have concluded that a simplified continuity measurement would suffice for contact resistance measurement of wraps in lieu of precision measurement. Factors influencing this conclusion include:

(a) The mechanical forces inherent in the formation of a wire wrapped joint are sufficient to insure an adequate electrical joint provided the mechanical aspects of the process remain closely controlled. Specifically, the Gastight Area and Strip Force Tests provide the primary criteria for determination of adequate electrical interface between the wrapper and wrapost.

(b) Relatively low cost milli-ohmmeters (Hp 432BA or equivalent) are now available which will afford convenient, rapid measurement with sufficient accuracy to obviate the need for precision measurement of wrapped joint resistance and will verify the existence of an adequate electrical connection.

(c) No failing, or even marginal, wrapper resistance measurements were observed during the Wire Wrap Evaluation Testing reported herein regardless of the applied environmental stress or the level of stress. This can be further expanded to state that in approximately seven years of Polaris/Poseidon wire wrap testing at the Naval Avionics Facility there have been no recorded Wrapper Resistance failures. Additionally, NAFI personnel know of no reported field failures of wrapped joints per se. Note that these latter statements are based primarily on the experience of NAFI personnel as well as informal discussions with personnel of other civilian and Government agencies associated with the Polaris/Poseidon systems.

(5) A wrapped connection that fails to comply with the strip force requirements of Specification WS-6119 may still be capable of complying with the wrapper resistance requirements of Specification WS-6119.

(6) Gas Tight Area - All wraps subjected to Gas Tight Area Tests, following all temperature exposures, were in compliance with the Gas Tight Area requirements of Specification WS-6119; however, the gas tight area under disturbed wraps of #26 and #30 AWG wire on both half-hard brass and beryllium copper wraposts was marginal following 15 days of 200°C temperature exposure.

(7) Embrittlement - No wire breakage was observed during the temperature test period when wrapped connections of all type wraps and gage wire were unwrapped in accordance with the procedure delineated in paragraph III.B.1, page 9, of this report.

(8) Visual Examination - Oxidation of the silver plating on the copper wire occurred during the 150°C and 200°C Temperature Tests in normal atmosphere. The silver plating became brown in color during the 30-day 150°C Temperature Test. During the 15-day 200°C Temperature Tests, the silver plating became black in color and would flake off the copper wire when the wire was flexed.

Milene insulation is unsatisfactory at a sustained temperature of 105°C. The Milene insulation became slightly brittle, peeled from some of the wraps, and showed signs of shrinkage after 5 days at 105°C.

Polysulfone insulation is unsatisfactory at a sustained temperature of 200°C. The polysulfone became brittle and cracked when flexed following a 200°C 15-day Temperature Test in normal atmosphere. Following a 15-day 200°C temperature exposure in a nitrogen atmosphere, the polysulfone insulation showed definite signs of shrinkage, however, the insulation did not become brittle.

2. Thermal Shock

a. Procedure - Individually wrapped virgin and previously vibrated connections of #26 and #30 AWG wire were subjected to Thermal Shock Tests in accordance with the procedures of Method 107B, Condition C, of Specification MIL-STD-202C. The vibrated wraps were polysulfone insulated virgin wraps which had been subjected to the Vibration Tests of paragraph IV.B.3. The connections were subjected to temperature extremes of -65°C for up to 5 complete cycles. These temperature extremes were based upon existing Standard Hardware Program (SHP) requirements except that, in keeping with the exploratory nature of this evaluation, the temperatures utilized were more severe than those required by SHP. The exposure time at each temperature extreme was 30 minutes with a maximum of 2 minutes at room temperature between temperature extremes. Prior to the Thermal Shock Tests, Strip Force and Embrittlement Tests were performed on a 20-connection reference sample of each type wrap of each gage wire. In addition, Wrapper Resistance Tests were performed on a sample of 10 connections of each type wrap for each gage wire after each temperature cycle and Wrapper Resistance Tests were performed on each sample of #30 AWG virgin wraps. The Performance Test results of the reference samples and temperature cycled samples were compared to determine the effect, if any, of the temperature cycling upon the test specimens. Ten connections of each type wrap were subjected to Gas Tight Area Tests following the five temperature cycles.

b. Results

(1) Visual Examination - No visual discrepancies were observed during or following the Thermal Shock Tests. It should also be noted that the polysulfone insulation showed no apparent physical damage such as shrinkage and embrittlement.

(2) Strip Force - In general, the average strip force of the wraps tested increased as the number of cycles of exposure was increased. As a result of the increase in strip force observed following the first temperature cycle, it was concluded that the 30-minute exposure to 200°C was of sufficient duration to effect the diffusion weld discussed previously herein. The average strip force values recorded in Table XVIII below indicate that this weld was strengthened by exposure to successive cycles of the Thermal Shock Test.

TABLE XVIII

AWG Wire Size	Type Wrap	Average Strip Force (Thermal Shock)					
		Ref	Average Strip Force in lbs				
			<u>1</u>	<u>2</u>	<u>3</u>	<u>4</u>	<u>5</u>
#30	Virgin	8.4	8.0	10.1	10.9	11.6	12.4
#30	Vibrated	8.8	10.6	10.7	11.0	12.1	13.2
#26	Virgin	13.9	22.9	21.1	27.4	28.1	28.2
#26	Vibrated	11.7	14.1	18.1	17.7	18.7	19.5

(3) Wrapper Resistance - No significant trends were observed from the wrapper resistance data of the #30 AWG virgin wraps. The average reference and successive cycle measurements were 0.51 mv., 0.54 mv., 0.56 mv., 0.55 mv., 0.55 mv., and 0.51 mv.

(4) Gas Tight Area - All wraps subjected to Gas Tight Area Tests following five temperature cycles were in compliance with the requirements of Specification WS-6119.

(5) Embrittlement - No wire breakage was observed when samples of each type wrap were subjected to the unwrap procedures delineated in paragraph III.B, page 9, of this report.

3. Vibration

a. Initial Vibration Test

(1) Procedure - In preparation for the Vibration Tests, approximately 1400 wrapped connections were fabricated on single width, 10-module connector plates. These connector plates were, in turn, secured (by clamps) to a test fixture suitable for mounting to a vibration table. The guiding philosophy in the design of the wire wrap assembly (depicted in Photograph 9 of Appendix A) was to create a fixture which would minimize any effects of the mounting structures on the vibration input to the wrapposts and consequently, to the wrapped connections. Both Sinusoidal and Random Vibration Tests were performed on the test fixture with Specification MIL-STD-810A used as a guideline.

The sample wraps were subjected to sinusoidal vibration for a total of four hours in each of three mutually perpendicular planes (vertical, transverse, and longitudinal). The frequency range and associated acceleration levels employed were consistent with those described by Figure 514-3, Curve G of Specification MIL-STD-810A with a maximum acceleration level of 50g. The

test fixture was vibrated for 20 minutes in each of the six resonant modes in each plane (two hours total resonance vibration) followed by two hours of cyclic vibration.

Following sinusoidal vibration, the sample wraps were subjected to random vibration for two hours in each of the three mutually perpendicular planes (longitudinal, transverse, and vertical, respectively). The frequency spectrum and vibration levels were as shown by Figure 514-4, Curve K of Specification MIL-STD-810A. The maximum frequency was 2000 Hz and the most severe vibration spectrum was $1.5g^2/\text{rms}$. Following is a physical description of the vibration test fixture and an explanation of test objectives.

(a) All connections were hand-wrapped connections of #26 and #30 AWG polysulfone insulated wire (approximately 700 connections of each gage wire).

(b) Similar circuit configurations of each gage wire were wrapped on four 10-module wire wrap connector plates. The connector plate wraposts were 0.025 x 0.025 x 0.50 inch beryllium copper wraposts. Two lengths of wire were used to fabricate the circuitry; 2.0 inch leads interconnecting pins of the same connector plate and 9-inch leads interconnecting pins of two separate connector plates. The wires were wrapped at various wrap levels with zero to three wraps per wrapost. The number of wraps per wrapost and wrap levels were selected such that most possible combinations of adjacent wrap levels could be monitored during vibration. The circuits were monitored in an effort to determine the following items with respect to type and direction of vibration.

1. Resonance modes of pins with various numbers and levels of wraps
2. Resonance modes of the 2.0 inch and 9 inch leads of #26 and #30 AWG wire on the different wrap levels
3. Whether adjacent pins contact each other during vibration, and if they do, determine whether the number of wraps, wrapper level(s), wire size and/or type and direction of vibration are factors
4. Whether the #26 and #30 AWG wire will withstand the sustained vibration, and if wire breakage occurs determine the length and gage wire, wrapper levels, type of vibration, and direction of vibration that causes the most damage.
5. Whether the 10-module connector plates and beryllium copper wraposts can withstand the vibration exposure.

(c) Circuit configurations similar to those described above were formed on a single-width, 10-module connector plate containing

0.025 x 0.025 x 0.75-inch beryllium copper wrapposts. Two identical circuits of #26 and #30 AWG wire were wrapped on four wrapper levels using 2-inch leads. The wire, wraps, and connector plate were monitored as indicated in the preceding paragraph.

(d) A circuit configuration composed of 1, 3, 4, 5, 6, and 8 inch leads of both #26 and #30 AWG wire was wrapped between four 2-module connector plates which contained 0.025 x 0.025 x 0.50-inch beryllium copper wrapposts. Two wires of each length and gage were wrapped on each of three wrapper levels to determine the resonance modes of the different lengths of wire with respect to type and direction of vibration and wrapper level.

(e) All connector plates were mounted as shown in Figure 3 of Appendix B. The connector plates were undamped (no modules utilized) and were clamped to the vibration fixture by aluminum brackets. Photograph 9 of Appendix A shows the circuit configuration and mounting of the connector plates. The photograph was taken following the vibration exposure.

(2) Results

(a) Sinusoidal Vibration - During the sinusoidal vibration period, 49 leads were broken. Forty-four of the broken leads were #30 AWG wire and only five broken leads were #26 AWG wire. Approximately 50 percent of the broken #30 AWG leads were 2.0 inches long and the remaining 50 percent were 9 inches long. All #26 AWG leads that broke were taut between wrapposts and were 4 inches in length or longer. Also, all broken leads (both #26 and #30 AWG) were wrapped on Z-2 or Z-3 wrap levels. The order of severity of the planes of vibration was: vertical (44 broken leads), transverse (5 broken leads), longitudinal (no broken leads). Most breakage is attributed to the insulated wrap loosening on the wrapost during the vertical vibration, thus allowing the wires to break at points which had been nicked when wrapped tightly around the wrapost. The remaining broken leads broke at sharp bends along the lead route or points adjacent to the wrapost. Photograph 10 of Appendix A depicts typical damage incurred during vibration. Many leads that broke at points adjacent to the wraposts were stretched tautly between wraposts. The wire gage, vibration plane, number of broken leads, and approximate lead length of the broken leads were as shown in Table XIX.

TABLE XIX

Broken Wires During 1st Vibration Test

Type Vibration	Plane	#26 AWG Length			#30 AWG Length			Total Broken Leads
		2"	4"	9"	2"	4"	9"	
Sinusoidal	Vertical	0	2	1	21	0	20	44
	Transverse	0	0	2	0	0	3	5
	Longitudinal	0	0	0	0	0	0	0

TABLE XIX (continued)

Type Vibration	Plane	<u>Broken Wires During 1st Vibration Test</u>						<u>Total Broken Leads</u>
		<u>#26 AWG Length</u>			<u>#30 AWG Length</u>			
		<u>2"</u>	<u>4"</u>	<u>9"</u>	<u>2"</u>	<u>4"</u>	<u>9"</u>	
Random	Longitudinal	1	0	5	5	3	7	21
	Transverse	0	0	6	3	0	0	9
	Vertical	11	2	24	24	0	18	79

The resonance modes of each gage wire, each wire length, and wraposts were not discrete. Due to the many variables such as wire tautness, lead routing, number of adjacent leads in parallel paths, and the location of the wrapped connections on the connector, only general ranges of frequencies of resonance modes were observed. It should also be noted that any changes in the wiring configuration may shift or change the resonance modes. Therefore, the results of this vibration exposure and ranges of resonant frequencies are applicable to the circuit configurations used during this test only and should not be construed as being representative of all wire wrap fixtures.

The following is a detailed exposition of the sinusoidal vibration results discussed on a per-plane basis.

1. Vertical Plane (Top-to-Bottom) - Vibration in the vertical plane caused the most damage during the sinusoidal vibration period. Forty-four leads (41 #30 AWG leads and 3 #26 AWG leads) were broken during vibration in the vertical plane. Approximately 30 of the leads broke during the period of cyclic vibration at frequencies between 5 and 2000 Hz. The remaining 11 leads were broken during resonance vibration.

Many resonance modes for #26 AWG wire, #30 AWG wire 1/2 inch wrapost, and 3/4 inch wraposts were observed. The sample wraps were vibrated for 20 minutes in each of the six most severe resonance modes; namely, 50 Hz, 74 Hz, 190 Hz, 430 Hz, 720 Hz, and 1030 Hz. Resonance vibration at 1030 Hz was the most severe for #30 AWG leads. Severe amplification of displacement of all lengths of #30 AWG leads was observed. At least 10 #30 AWG leads of various lengths were broken during the 1030 Hz resonance vibration. Resonance vibration at 55 Hz was the most severe for #26 AWG wire. Two 4-inch #26 AWG leads broke during resonance vibration at 55 Hz. The general range of frequencies in which amplified displacement of leads and wraposts were observed are as follows:

a. #26 AWG leads - Resonance modes observed at many frequencies between 30 Hz and 250 Hz

b. #30 AWG leads - Resonance modes observed at many frequencies between 30 Hz and 600 Hz

c. 0.025 x 0.025 x 0.50-inch beryllium copper wraposts - Resonance modes were observed at many frequencies between 700 Hz and 1600 Hz. In general wraposts with wraps on the Z-2 and/or Z-3 levels tended to resonate at the lower frequencies and unwrapped wraposts resonated at the higher frequencies. Between the frequencies of 1000 and 1100 Hz the wraposts were being whipped by the severe displacement of the #30 AWG leads.

d. 0.025 x 0.025 x 0.75-inch beryllium copper wraposts - Resonance modes were observed at many frequencies between 400 Hz and 1500 Hz. These wraposts exhibited behavior similar to that described in c. above; however, the 3/4 inch wraposts exhibited more displacement. At frequencies of approximately 430 Hz, adjacent wraposts with wraps on the Z-3 and/or Z-4 levels may have contacted each other if uninsulated wire had been used. The insulated turns of the adjacent wraps appeared to be touching during resonance modes; thus, preventing intermittent short circuits between wraposts.

2. Transverse Plane (Side-to-Side) - Five leads 9 inches in length broke during vibration in the transverse plane (three #30 AWG leads and two #26 AWG leads). All five leads were broken at points adjacent to the wrapost. Three of the leads (one #26 AWG and two #30 AWG) broke during the period that the vibration frequency was being cycled from 5 to 2000 Hz. Two leads (one of each gage wire) broke during resonance vibration at 30 Hz.

Many resonance modes for #26 AWG wire, #30 AWG wire, 1/2 inch wraposts, and 3/4 inch wraposts were observed. The six most severe resonance modes were 30 Hz, 85 Hz, 150 Hz, 240 Hz, 810 Hz, and 1150 Hz. The resonance vibration at 30 Hz, and 240 Hz resulted in the maximum displacement of 9-inch leads of both gage wire. The general range of frequencies in which amplified displacement of leads and wraposts were observed are as follows:

a. #26 AWG leads - Resonance modes were observed at many frequencies between 27 and 615 Hz for 9-inch leads and 1050 to 1650 for 2-inch leads.

b. #30 AWG leads - Resonance modes were observed at many frequencies between 27 and 930 Hz for 9-inch leads and 18 to 1260 Hz for 1-1/2 inch leads.

c. 0.025 x 0.025 x 0.50-inch beryllium copper wraposts - Amplified displacement of 1/2 inch wraposts was observed between frequencies of 600 and 2000 Hz; however, at frequencies of 240 and 380 Hz, 9-inch leads of both gage wire tended to whip the 1/2 inch wraposts. In general, the wraposts followed the trends established during vibration in the vertical plane; i.e., wraposts with connections on Z-2 and/or Z-3 wrapper levels resonate at the lower frequencies, wraposts with connections on both

the Z-1 and Z-2 wrapper levels or on the Z-1 wrapper level only resonate at the mid-frequencies, and wraposts with no connections resonate at the upper frequencies.

d. 0.025 x 0.025 x 0.75-inch beryllium copper wraposts - Amplified displacement of 3/4 inch wraposts was observed between frequencies of 500 to 1100 Hz. These wraposts exhibited behavior similar to that described in c. above.

3. Longitudinal Plane (Parallel with Lead Paths) - Vibration in the longitudinal plane was the least severe direction of vibration. No leads were broken during vibration in the longitudinal plane.

Several resonance modes for #26 AWG leads, #30 AWG leads, 1/2 inch wraposts, and 3/4 inch wraposts were observed. The six most severe resonance modes were 47 Hz, 220 Hz, 615 Hz, 1050 Hz, and 1260 Hz; however, only minor amplification of displacement of leads and/or wraposts were observed at any frequency. The general range of frequencies in which amplified displacement was observed are as follows:

a. #26 AWG leads - Amplified displacement of 9-inch leads between frequencies of 66 to 380 Hz and 1-1/2 inch leads between frequencies of 660 to 1700 Hz was observed.

b. #30 AWG leads - Amplified displacement of 9-inch leads between frequencies of 13 to 380 Hz and 1-1/2 inch leads between frequencies of 810 and 1800 Hz was observed.

c. 0.025 x 0.025 x 0.50-inch beryllium copper wraposts - The resonance modes of 1/2 inch wraposts were between the frequencies of 615 and 2000 Hz. The resonance modes for 1/2 inch wraposts when vibrated in the longitudinal plane followed the same trends with respect to wrapper levels as described in paragraph IV.B.3.a(2)(a)1.c, page 39 or IV.B.3.a(2)(a)2.c, page 39.

d. 0.025 x 0.025 x 0.75-inch beryllium copper wraposts - The resonance modes of 3/4 inch wraposts were between the frequencies of 600 and 900 Hz. The resonance modes for 3/4 inch wraposts when vibrated in the longitudinal plane followed the same trends with respect to wrapper levels as described in paragraph IV.B.3.a(2)(a)1.d, page 39 or IV.B.3.a(2)(a)1.d, page 40.

(b) Random Vibration - The damage caused by random vibration was considerably more severe than the damage caused by sinusoidal vibration. During the random vibration period, a total of 109 leads and 16 wraposts were broken. Random vibration in the vertical plane (as with

sinusoidal vibration in the vertical plane) caused the most severe damage. Seventy-nine leads and 16 wraposts were broken during the vertical vibration exposure, as compared to 21 leads broken in the longitudinal plane and 9 broken leads in the transverse plane. The gage wire, vibration plane, number of broken leads and approximate lead lengths of the broken leads were as shown in Table XIX on pages 35 and 36 of this report. Most lead breakage is attributed to the causes delineated in the foregoing discussion of sinusoidal vibration results, paragraph IV.B.3.a(2)(a), page 35.

1. Most breakage of #30 AWG wire was caused by the insulated wrap loosening on the wrapost during the vertical vibration exposure, thus allowing wires to break at points which had been nicked when wrapped tightly around the wrapost. Photograph 10 of Appendix A depicts the loosened #30 AWG wraps. Note also that most #26 AWG wraps still appear to be tightly wrapped around the wraposts. The photograph was taken after completion of the initial Vibration Test.

2. The majority of the broken #26 AWG wire and most of the remaining #30 AWG broken leads broke at some point on the insulated portion of the wrap (see Photograph 10 of Appendix A).

3. A few #30 AWG leads broke at sharp bends in the lead route (see Photograph 10 of Appendix A).

It should be noted that only five #26 AWG leads were broken during the sinusoidal vibration exposure, whereas 49 #26 AWG leads were broken during the random vibration exposure. The cause of more broken #26 AWG leads during the random vibration exposure may be due to random vibration being generally a more severe type vibration and/or fatigue due to the total length of time the sample wraps had been subjected to vibration exposure (18 hours).

A metallographic analysis by the NAFI Metallurgical Materials Branch (B/033.2) disclosed that all breakage of beryllium copper wraposts could be attributed to metal fatigue. Wrapost breakage was limited to pins located on the peripheries of the 10-module connector plates where, due to reduced wire and wrapost density, there was little resistance to the extreme wrapost displacement experienced during vibration. All wraposts broken as a result of vibration contained at least two wraps, and the connections on 14 of the 16 broken wraposts were wrapped with #26 AWG wire. Photograph 11 of Appendix A depicts a broken wrapost while Photograph 12 of Appendix A provides a visual comparison of a wrapost broken by metal fatigue (during vibration) and a wrapost broken by bending it beyond its yield point.

(c) Synopsis of First Vibration Exposure

1. Vibration in the vertical plane, whether random or sinusoidal vibration, is the most severe direction of vibration and causes the most damage.

2. The random vibration exposures conducted were more severe than were the sinusoidal exposures.

3. Wrapost breakage, which occurred only during random vibration in the vertical plane, is attributed to metal fatigue of the beryllium copper wrapposts. The breakage occurred only in the peripheral rows of the 10-module connector plates and primarily on wrapposts which contained two or more connections of #26 AWG wire.

4. Most breakage of #30 AWG wire was caused by the insulated turns of the wrapped connections loosening during vertical vibration, thus allowing the insulated turns of the wrap to slide up and down on the sharp edges of the wrapost causing breaks to occur in the wrapped portion of the connection.

5. Most breakage of the #26 AWG wire was at the initial point of contact between the insulated wrap and the wrapost. The insulated turns of the wrap were held rigidly to the wrapost with the lead of the wrap free to flex about during vibration, thus metal fatigue of the wire at the point where the wire is rigidly held to the wrapost allows the wire to break.

6. Resonance modes during sinusoidal vibration are dependent upon the direction of vibration, gage wire, length of lead, wrapper level, length wrapost, wire tautness, lead routing, adjacent leads, location of the wrapped connection, connector plates, and possibly other unknown variables. Therefore, each circuit designed should be individually vibration tested.

7. Following the completion of the random and sinusoidal vibration exposures, a visual examination revealed that all five 10-module wire wrap connector plates had cracked during the vibration exposure. The cracks were located in the aluminum mounting plates of the 10-module connector plates and followed a path through the keying and mounting holes. The cracks were formed at the edge of the bracket that clamped the mounting plate to the vibration fixture. Photograph 13 of Appendix A depicts a representative crack in one of the mounting plates.

b. Second Vibration Test

(1) Procedure - Since the initial Random Vibration Test proved to be extremely destructive, it was felt that a second test, conducted at less severe vibration levels, might provide more useful information as to the vibration characteristics and capabilities of solderless wrapped connections. As a result, a second wire wrap assembly containing approximately 1200 wrapped connections was subjected to a random vibration exposure in the vertical plane only. The wire wrap assembly was vibrated for one hour at each of the Vibration Test levels described by Curves A, C, E, G, J, and K of Figure 514-4 of Specification MIL-STD-810A. Vibration was

initiated at the lowest level and increased in severity through the highest (or most severe) level of exposure. The frequency range of vibration was 50 to 2000 Hz in each case, and the power spectral density and overall rms g level of each exposure were as shown in Table XX below.

TABLE XX

Random Vibration Test Curve Levels

<u>Test Curve*</u>	<u>Power Spectral Density g^2 / Hz</u>	<u>Overall rms g Minimum</u>
A	0.02	5.3
C	0.06	9.3
E	0.2	16.9
G	0.4	23.9
J	1.0	37.8
K	1.5	46.3

* - See Figure 514-4 of Specification MIL-STD-810A

Photograph 14 of Appendix A depicts the circuit layout and mounting of the 10-module connector plates of the wire wrap test fixture used in the second Vibration Test. The objectives and fabrication characteristics of the wire wrap fixture are as follows:

(a) All connections were hand-wrapped connections of #26 AWG and #30 AWG polysulfone insulated wire (approximately 600 connections of each gage wire).

(b) Similar circuit configurations of each gage wire were wrapped on two pairs of 10-module wire wrap connector plates. The connector plate wraposts were 0.025 x 0.025 x 0.50-inch beryllium copper wraposts. Three lengths of wire were used to fabricate the circuitry: 1-1/2 and 2 inch leads interconnecting wraposts of the same connector plate and 9 inch leads interconnecting wraposts of the paired connector plates. As in the first Vibration Test, the wires were wrapped at various wrap levels with zero to three wraps per wrapost. The number of wraps per wrapost and wrap levels were selected such that the most possible combinations of adjacent wrap levels could be monitored during vibration. The basic combination of the number of wraps and wrapper levels used during the first Vibration Test were used in the second Vibration Test also.

(c) Each of the four 10-module connector plates was rigidly mounted to the vibration fixture by eight No. 4 screws in lieu of the clamping device used in the first Vibration Test. The screws were used to mount the connector plates in an effort to determine if a different type of mounting would prevent damage to the connector plates. Figure 4 of Appendix C depicts the mounting of the connector plate.

(d) In addition to a different type mounting of the connector plates, Type 3 Module Headers were used to damp three of the connector plates. Two of the connector plates were damped by three Type 3 Module Headers each. The headers were inserted into the connector plates, one at each end and one near the center of the plates. The third connector plate was damped on one end only by one Type 3 Module Header. Thus, the center and opposite end were not damped. The fourth connector plates was not damped. The damping of the connector plates was provided in varying degrees (number and location of Type 3 Module Headers in each connector plate) to determine the effect of damping with respect to wire and wrapost breakage.

In addition, the Type 3 Module Headers were utilized to supply voltages and circuit paths to the wire wrap circuitry. A 1000 volt potential was applied by a hypot tester to 120 wraposts and a ground potential was continuously applied to the adjacent wraposts. Each of the wraposts contained zero to three wraps of #26 or #30 AWG wire. During the vibration period, the wraposts were monitored by the hypot tester and visually to determine if voltage breakdown between wraposts occurred. Also, two continuous circuits, each containing 10 wraps and 20 mating connections between the female contacts of the wrapost and male contacts of the headers, were monitored with a Relay Contact Vibration Test Set to determine if discontinuities between the mated male and female contacts occur. The Relay Contact Vibration Test Set supplies 28 volts d-c to the circuits and will measure discontinuities of 10 usec or greater.

Photograph 15 of Appendix A depicts three Type 3 Module Headers inserted in a 10-module wire wrap connector plate. Figure 4 of Appendix B depicts the mounting of the connector plate and header on the vibration fixture.

(e) The wire wrap samples were subjected to random vibration in the vertical plane only during the second Vibration Test because:

1. Previous test results had indicated that the vertical plane of vibration would provide comparatively more information relative to wire wrap vibration capability

2. It was desired to minimize wire fatigue as a factor in wire breakage by reducing exposure time

(2) Results - The results of the second vibration exposure were as follows:

(a) No voltage breakdown or arcing was observed between wraposts during any test level of vibration when potentials as high as 1000 volts were applied.

(b) No contact bounce or intermittent conditions were indicated by the Relay Contact Vibration Test Set at any test level of vibration.

(c) No 10-module connector plates were fractured during the vibration period.

(d) No wire or wrapost breakage was observed at the test level of Curve G ($0.4g^2/Hz$) and below.

(e) No wire or wrapost breakage was observed at any test level of vibration on the two 10-module wire wrap connector plates which were damped by three Type 3 Module Headers.

(f) No wire or wrapost breakage was observed on the damped end of the 10-module wire wrap connector plate at any test level of vibration.

(g) Nine wires and five wraposts were broken during vibration at the test levels of Curves J ($1.0g^2/Hz$) and K ($1.5g^2/Hz$). All broken wires and wraposts were located on the undamped 10-module wire wrap connector or on the undamped sections of the partially damped 10-module wire wrap connector plate. Two of the broken wraposts contained one wrap of #26 AWG wire on the Z-3 wrapper level, and the remaining three broken wraposts contained a single connection of #30 AWG wire on the Z-3 wrapper level; however, two of the three broken wraposts, which were wrapped with #30 AWG wire, broke after the #30 AWG lead to the wraps had broken. Three of the broken wraposts were on the outside rows of the connector plates, and two broken wraposts were from the interior sections of the connector plates. Wire and wrapost breakage were as listed in Table XXI below.

TABLE XXI

Breakage During Second Vibration Test

MIL-STD-810 Curve	Power Spectral Density g^2/Hz	#26 AWG Wire Breakage		#30 AWG Wire Breakage		Wrapost Breakage
		2"	8"	2"	8"	
A-C-E-G	0.02-0.06-0.2-0.4	0	0	0	0	0
J	1.0	1	0	4	0	2
K	1.5	0	1	1	2	3*

* - The leads to two of the three broken wraposts broke prior to the wrapost breakage.

(h) Considering that the wire wrap samples were subjected only to random vibration in the vertical plane during the second vibration exposure and that the results of the first vibration exposure indicate that this is the most severe type and plane of vibration, the results of the second vibration exposure indicate that:

1. Mounting the 10-module connector plates with screws in lieu of the clamping arrangement utilized in the first Vibration Test reduces the possibility of fractures occurring in the mounting plates.

2. Damping the rigidly mounted 10-module wire wrap connector plates appears to minimize wire and wrapost breakage, since no wires or wraposts were broken from the damped connector plates or the damped portion of the partially damped connector plate.

3. Although no arcing between wraposts was observed when potentials up to 1000 volts d-c were applied, it is not considered to be conclusive evidence that arcing would not occur at various resonance modes of sinusoidal vibration.

4. Wire wrap circuitry wrapped on beryllium copper wraposts on 10-module wire wrap connector plates can sustain the Class II vibration requirements of the Standard Hardware Program if the 10-module wire wrap plates are properly damped and rigidly mounted with screws, since:

a. Class II Standard Hardware requirements specify a maximum random vibration spectrum of $0.2g^2/Hz$ (Curve E, Figure 514-4 of Specification MIL-STD-810A) whereas, no wire or wrapost breakage was observed during the subject test until a vibration level of $1.0g^2/Hz$ had been reached.

b. The length of vibration exposure at each test level was exactly twice that required by Specification MIL-STD-810A and Standard Hardware specifications.

4. Salt Spray Exposure - During the course of several years of wire wrap qualification testing for the Polaris and Poseidon systems, numerous wire wrap samples have been subjected to salt spray exposure. This exposure consisted of a conventional 48-hour, 5% salt solution test as described in MIL-STD-810A Method 509. Results of all such exposures have been similar and relatively independent of wire size or wire type. Essentially the electrical performance has in all cases been unaffected by the exposure in-so-far as wrapper resistance (contact resistance) of the wrapped joint is concerned. While corrosion products (complex chloride salts) do form at wrapped joints, Gastight Area Tests have demonstrated that these corrosion products do not permeate the wrapped joint sufficiently during the 48-hour exposure to affect either the mechanical or electrical integrity of the wrapped joints. In fact, corrosion products present at wrapped joints cause a significant increase in the Strip Force of the wrapped joints leading to the plausible conclusion that at least the mechanical integrity of the wrapped joint may actually be improved by salt spray exposure.

NOTE: All references herein to wire wrap or wire wrap processes infer materials and processes equivalent to those required by Specification WS-6119 and are not intended to include the wire wrap technique in a generalized sense wherein lesser grade materials and/or process controls may be utilized.

The results obtained from conventional 48-hour Salt Spray Tests warrant additional testing to explore:

- a. Long term salt spray exposure effects on wire wrapped connections.
- b. The tendency for individual components comprising wire wrapped connections (wire and wraposts) to corrode during salt spray exposure.
- c. Acceleration of corrosion resulting from damage (scratches, necks and gouges) to wire and wraposts.
- d. Effects of previous electrical tests (particularly current overload) on the ability of a wrapped connection to withstand corrosive environments.

(1) Procedure

(a) In order to implement the above investigation, individual samples of wire and wraposts, identical to those used in the construction of the Module Assembly, were selected for prolonged salt spray exposure. Twenty short lengths of #30 AWG OFHC wire, twenty lengths of #30 AWG alloy wire, and twenty 0.025-inch square beryllium copper wrapost samples were selected. Each sample of wire types was further divided into five groups with each group containing four wire samples stripped (of insulation) on each end as would be done prior to a wrapping process. The twenty wrapost samples were also divided into five groups (four posts per group) with two wraposts from each group being intentionally scratched through the gold plating. The samples were exposed to a 5 percent salt solution at an ambient temperature of 35°C, with one group of each sample type (alloy wire, OFHC wire, and wrapost) being removed from the test chamber at time intervals of 24, 48, 72, 144, and 168 hours and inspected for corrosive damage.

In addition to the wire and wrapost samples cited above, three special test boards containing wrapped connections of #30 AWG Alloy, #30 AWG OFHC and #26 AWG OFHC wire were fabricated for intended salt spray exposure. All connections were handwrapped and the test circuit configurations consisted of:

1. Special Test Board No. 1 - Comprised of six circuits of eight wraps each, #30 AWG wire. Three of the circuits were fabricated using alloy wire, while the remaining three circuits utilized OFHC wire.

2. Special Test Board No. 2 - Comprised of three circuits of Alloy wire and two circuits of OFHC with 20 wraps per circuit of # 30 AWG wire. An additional 15 individual wraps of each wraps of each type were also provided on the board.

3. Special Test Board No. 3 - Comprised of three circuits of #26 AWG OFHC wire with 20, 12 and 16 wraps per circuit respectively (total of 48 sample wraps) and four of #30 AWG wire with 12 wraps per circuit (total of 48 sample wraps).

(b) All connections for the above special test boards were wrapped on 0.025-inch square beryllium copper wrapposts. Test Boards Nos. 1 and 2 were utilized primarily for observed effects of salt spray exposure while Special Test Board No. 3 was reserved for determining the effect of long term exposure on wrapper resistance.

Prior to the salt spray exposure Special Test Boards Nos. 1 and 2 were "treated" as follows:

1. Millivolt Drop Tests were conducted on all circuits on Board No. 1 and half the circuits on Board No. 2.

2. Current Overload Tests were performed on one circuit of alloy wire and one circuit of OFHC wire.

3. Five connections each of alloy and OFHC wire unwrapped and rewrapped five times with the final wrap left on.

4. Several connections were intentionally damaged (scratched, nicked, or gouged).

5. Wrapper Resistance Tests were performed on the connections that were not connected as circuits.

Special Test Boards Nos. 1 and 2 were removed for observation after 48 hours of exposure and again at 100 hours of exposure.

Special Test Board No. 3 was subjected to wrapper resistance tests prior to exposure to establish reference data. The board was removed from the salt spray chamber after 100 hours of exposure and again at 240 hours of exposure for additional wrapper resistance measurements. Measured data were then analyzed to detect changes in wrapper resistance attributed to the exposure.

(2) Results

(a) Observed Salt Spray Exposure Effects - Special Test Boards Nos. 1 and 2.

Following the 48 and 100-hour salt spray test exposures, the wrapped connections of Special Test Boards Nos. 1 and 2 were visually examined and subjected to Millivolt Drop and Wrapper Resistance Tests. No significant changes in the electrical characteristics of the connections were apparent; however, many of these connections were heavily corroded.

Photograph 16 of Appendix A depicts this corrosion. Several of the corroded connections (wire and wrapost) were submitted to the NAFI Materials Laboratory (D/033) for a chemical analysis. The results of Electrical Performance Tests, visual examination and chemical analysis were as follows:

1. Corrosion on the wrapped connections was a complex chloride salt containing all the metals of the wrapost and the wire.

2. Corrosion once begun, progresses beneath the conductor plating. The wire comprising the wrap was severely pitted with the corrosion extending beneath the tin plating.

3. No difference in severity of corrosion was observed between OFHC and Alloy wire.

4. Corrosion in the form of copper oxide formed on both the alloy and OFHC wire and became progressively more severe as the exposure time was increased.

5. Wire corrosion started in areas where the tin plating had been inadvertently removed exposing the conductor; e.g., at the wire tip or where the insulation was cut to initiate the wire strip.

6. Copper chloride formed in very small quantities on the wraposts except where the gold plating was nicked. Here, and in areas of imperfect plating, corrosion was heavy.

7. Electrically, the wire wrap connections were essentially unaffected by the 100-hour salt spray exposure.

8. Corrosion on the rewrapped connections was significantly heavier than that on virgin wraps at any given time during the exposure.

9. Previous electrical tests did not seem to influence the rate or degree of corrosion.

10. Although heavily corroded, no wrapped connection failed to comply with the electrical requirements of WS-6119 following 100 hours of salt spray testing.

(b) Electrical Test Results (Wrapper Resistance) - Special Test Board No. 3.

Results of wrapper resistance measurements for Special Test Board No. 3 are summarized in Table XXII below. Visual examination of Board No. 3 yielded results essentially identical to those of Special Test Boards Nos. 1 and 2.

Table XXII

Wrapper Resistance Sample Statistics for
Special Test Circuit No. 3

<u>#26 AWG OFHC Wire</u>			
	<u>Initial Wrapper Resistance (Mv)*</u>	<u>Wrapper Resistance Following 100-hour Exposure (Mv)</u>	<u>Wrapper Resistance Following 240-hour Exposure (Mv)</u>
Range (R)	0.9 — 0.4	0.9 — 0.3	1.1 — 0.4
Sample Mean (\bar{X})	0.67	0.63	0.70
Standard Deviation (S_x)	0.15	0.19	0.21
<u>#30 AWG OFHC Wire</u>			
	<u>Initial Wrapper Resistance (Mv)*</u>	<u>Wrapper Resistance Following 100-hour Exposure (Mv)</u>	<u>Wrapper Resistance Following 240-hour Exposure (Mv)</u>
Range (R)	0.9 — 0.1	1.0 — 0.4	0.9 — 0.4
Sample Mean (\bar{X})	0.65	0.68	0.65
Standard Deviation (S_x)	0.20	0.18	0.18

*Mv - Millivolts drop across the wrapped joint, with 2.4 amperes for #26 AWG Wire and 1.0 amperes for #30 AWG Wire flowing through the joint.

NOTE: Sample sizes, N, for each exposure condition and for each wire size in Table XXII above were 48 wrapped connections.

The effect of salt spray exposure on wrapped connections may be investigated by formulating the hypothesis $H_0: \mu_1 = \mu_2$, against the alternate hypothesis $A_0: \mu_1 \neq \mu_2$

μ_1 = mean value of wrapper resistance following salt spray exposure

μ_2 = preexposure (initial) mean value of wrapper resistance

and applying a t-test to the data of Table XXII at 100 hours and 240 hours of salt spray exposure to establish an accept-reject decision for H_0 . If results of the t-test indicate that H_0 must be rejected at a selected level of significance, then it should be concluded that salt spray exposure does affect wrapper resistance in accordance with the alternate hypothesis

As: $\mu_1 \neq \mu_2$. However, should results of the t-test indicate acceptance of $H_0: \mu_1 = \mu_2$, it may then be concluded that the means are equal and that salt spray exposure does not affect wrapper resistance. Table XXIII below presents the results of a two-tailed t-test applied to data of Table XXII at the 10% level of significance ($\alpha = 10\%$) in accordance with

$$\text{Computed } t = \frac{\bar{X}_1 - \bar{X}_2}{S_P \sqrt{\frac{1}{N_1} + \frac{1}{N_2}}} \quad \text{Where: } S_P = \sqrt{\frac{N_1 S_{x_1}^2 + N_2 S_{x_2}^2}{N_1 + N_2 - 2}}$$

- N = Sample size
- \bar{X}_2 = Preexposure Sample mean
- \bar{X}_1 = Sample mean following Salt Spray exposure
- S_{x_2} = Preexposure Sample standard deviation
- S_{x_1} = Sample Standard deviation following Salt Spray exposure
- S_P = Pooled estimate of the population standard deviation

The accept-reject criteria, $t_{(1 - \frac{\alpha}{2})(N_1 + N_2 - 2)}$, is obtained from standard tables of cumulative t-distribution¹.

Table XXIII

Two-tailed t-test of Wrapper Resistance Sample Means at 100 hours and 240 hours of salt spray exposure.

#26 AWG OFHC Wire

<u>Exposure Time</u>	<u>\bar{X} (mv)</u>	<u>S_x (mv)</u>	<u>Computed "t"</u>	<u>$t_{(1 - \frac{\alpha}{2})(N_1 + N_2 - 2)}$ for $\alpha = 10\%$</u>	<u>Decision at $\alpha = 10\%$</u>
100 hours	0.63	0.19	-1.13	±1.29	Accept H_0
240 hours	0.70	0.21	+0.80	±1.29	Accept H_0

#26 Wire Initial Performance Data: $\bar{X}_2 = 0.67$ mv; $S_{x_1} = 0.15$ mv

¹ Table of Cumulative t-Distribution, p 528
Bernard Ostle, "Statistics in Research, The Iowa State University Press, 1963

Table XXIII (Continued)

Exposure Time	\bar{X} (mv)	S_x (mv)	Computed "t"	t	Decision at $\alpha = 10\%$
				$\frac{(1-\frac{\alpha}{2})(N_1+N_2-2)}{\text{for } \alpha = 10\%}$	
100 hours	0.68	0.18	+0.77	11.29	Accept Ho
240 hours	0.65	0.18	0	11.29	Accept Ho

#30 wire Initial Performance Data: $\bar{X}_2 = 0.65\text{mv}$ $S_{x2} = 0.20$ millivolts.

From Table XXIII it is seen that Ho is accepted at the 10% level of significance for both wire sizes and both durations of exposure. It can therefore be concluded that the sample means are equal and that 5% salt spray exposures of up to 240 hours in duration have no effect on the wrapper resistance of #26 and #30 AWG OFHC wire wrapped connections.

NOTE: The t-test was applied at a 10% level of significance ($\alpha = 10\%$) rather than at a 5% or 1% level to provide a more powerful test of rejection, and hence to increase confidence in the acceptance of Ho.

5. Remarks

In view of the fact that considerable history of wire wrap testing at the Naval Avionics Facility has failed to disclose a single defective (out-of-tolerance) wrapped connection (insofar as wrapper resistance is concerned), and since there have been no "reported" field failures of wrapped joints per se, it seems appropriate to further examine the parameter of wrapper resistance with respect to the limit of 4.0 millivolts stipulated by WS-6119. Testing history would tend to indicate that the limit is conservative, but no estimates have been provided which attempt to quantify the degree of conservatism involved in the limit of 4.0 millivolts.

Interval estimates of population parameters for wrapper resistance can be derived from the data of Table XXII by calculating confidence intervals between both the sample means and standard deviations. To simplify the following discussion, confidence intervals have been calculated only from the initial wrapper resistance sample mean and standard deviation for #30 AWG OFHC wrapped connections, $\bar{X} = 0.65$ millivolts and $S_x = 0.20$ millivolts respectively

a. One-Sided Upper 99% Confidence Limit for the Mean

$$\mu < \bar{X} + t_{\alpha} \frac{S_x}{\sqrt{N}}$$

$$\mu < 0.65 + 0.07 = \underline{0.72}$$

where $t_{\alpha} = 2.41$ for 99% confidence (from standard tables of cumulative t-distribution)

$N = 48$ sample connections

b. One-Sided Upper 99% Confidence Limit for the Standard Deviation

$$\sigma < \frac{S_x \sqrt{N}}{\sqrt{\chi^2 (1 - \gamma)(v - 1)}}$$

$$\sigma < \underline{\underline{0.26}}$$

where $\chi^2_{(0.01)} = 27.4$ (from tables of chi-Square distribution for $\gamma = 99\%$, $v - 1 = 47$ degrees of freedom)

From the above calculations it can be stated with 99% confidence that population mean of wrapper resistance will lie in an interval below 0.72 millivolts while the standard deviation will be less than 0.26 millivolts.

Based on the calculated confidence limits a conservative worst case assumption can be made that the population values for wrapper resistance actually are the upper limits of the confidence interval or, $\mu = 0.72$ millivolts and $\sigma = 0.26$ millivolts respectively. Then, in the worst case estimate of population parameters, the mean is approximately 13 standard deviations from the specified limit of 4.0 millivolts. That is;

$$\mu = \frac{4.00 - 0.72}{0.26} = 13 \text{ } \sigma\text{'s from the specified limit of 4.0 millivolts.}$$

It can be shown from Tables of cumulative standard normal distribution that a range of only four standard deviations (4 σ 's) from the mean will encompass 99.997% of the population, i.e., only 0.003% of the population would exist above a limit of $\mu + 4\sigma$. Since even the worst case estimates of μ and σ for wrapper resistance illustrate that the population mean is at least 13σ from the specified limit, it is obvious that there is considerably less than a 0.003% chance of finding a defective wrapped connection (out-of-tolerance wrapper resistance) in any given test sample. Alternately stated, in the testing of 100,000 wrapped connections of #30 AWG OFHC wire, it is conservatively estimated that fewer than three out-of-tolerance wrapped connections would be detected.

While the above estimates were restricted to the initial wrapper resistance values for #30 AWG OFHC wrapped connections, similar estimates were derived for other data of Table XXII irrespective of wire size or exposure duration.

From the estimates above it is easily seen that in past testing of wrapped connections it would have been unlikely that an out-of-tolerance wrapper resistance measurement might have been observed. It can also be stated that it is unlikely that future testing will reveal an out-of-tolerance connection provided the physical and mechanical process controls of wire wrap are maintained at present levels. However, these statements are not to be construed as constituting rationale for deletion of the wrapper resistance requirement since some form of continuity

NAFI TR-1242

measurement is necessary to assure electrical integrity of the wrapped connections. However, a simplified method of continuity, or contact resistance, measurement as proposed in paragraph IV.B.1.f.(4)(b), page 31 of this report would appear indicated.

APPENDIX A

PHOTOGRAPHS

	<u>Page No.</u>
1. Photograph 1 - Oxidation of Silver Plated Wire During 200°C Temperature Exposure	A.3
2. Photograph 2 - Unwrapped Wraposts of #26 AWG Connections Following Gas Tight Area Tests (Beryllium Copper Wraposts)	A.4
3. Photograph 3 - Unwrapped Wraposts of #30 AWG Connections Following Gas Tight Area Tests (Beryllium Copper Wraposts)	A.5
4. Photograph 4 - Unwrapped Wraposts of #26 AWG Connections (Beryllium Copper Wraposts)	A.6
5. Photograph 5 - Unwrapped Wraposts of #30 AWG Connections (Beryllium Copper Wraposts)	A.7
6. Photograph 6 - Unwrapped Wraposts of #26 and #30 AWG Connections Following 200°C Temperature Exposure and Gas Tight Area Tests (Half-Hard Brass Wraposts)	A.8
7. Photograph 7 - Unwrapped Wraposts of #26 AWG Connections (Half-Hard Brass Wraposts)	A.9
8. Photograph 8 - Unwrapped Wraposts of #30 AWG Connections (Half-Hard Brass Wraposts)	A.10
9. Photograph 9 - Wire-Wrap Fixture Used During Initial Vibration Exposure	A.11
10. Photograph 10 - Typical Damage Incurred During Initial Vibration Test	A.12
11. Photograph 11 - Wrapost Broken During Initial Vibration Test .	A.13
12. Photograph 12 - Wrapost #1 - Break Due to Metal Fatigue During Initial Vibration Exposure; Wrapost #2 - Break Caused by Bending Wrapost Beyond its Breaking Point (for comparison purposes)	A.14

13.	Photograph 13 - Crack in Mounting Plate of a 10-row Connector Plate (Occurred During Initial Vibration Test)	A.15
14.	Photograph 14 - Wire-Wrap Fixture Used in the Second Vibration Test	A.16
15.	Photograph 15 - Type 3 Module Headers Mounted in a 10-row Connector Plate	A.17
16.	Photograph 16 - Typical Back Panel Wire Wrap Connections Depicting Corrosion Products Following 48-hour Salt Spray Exposure	A.18

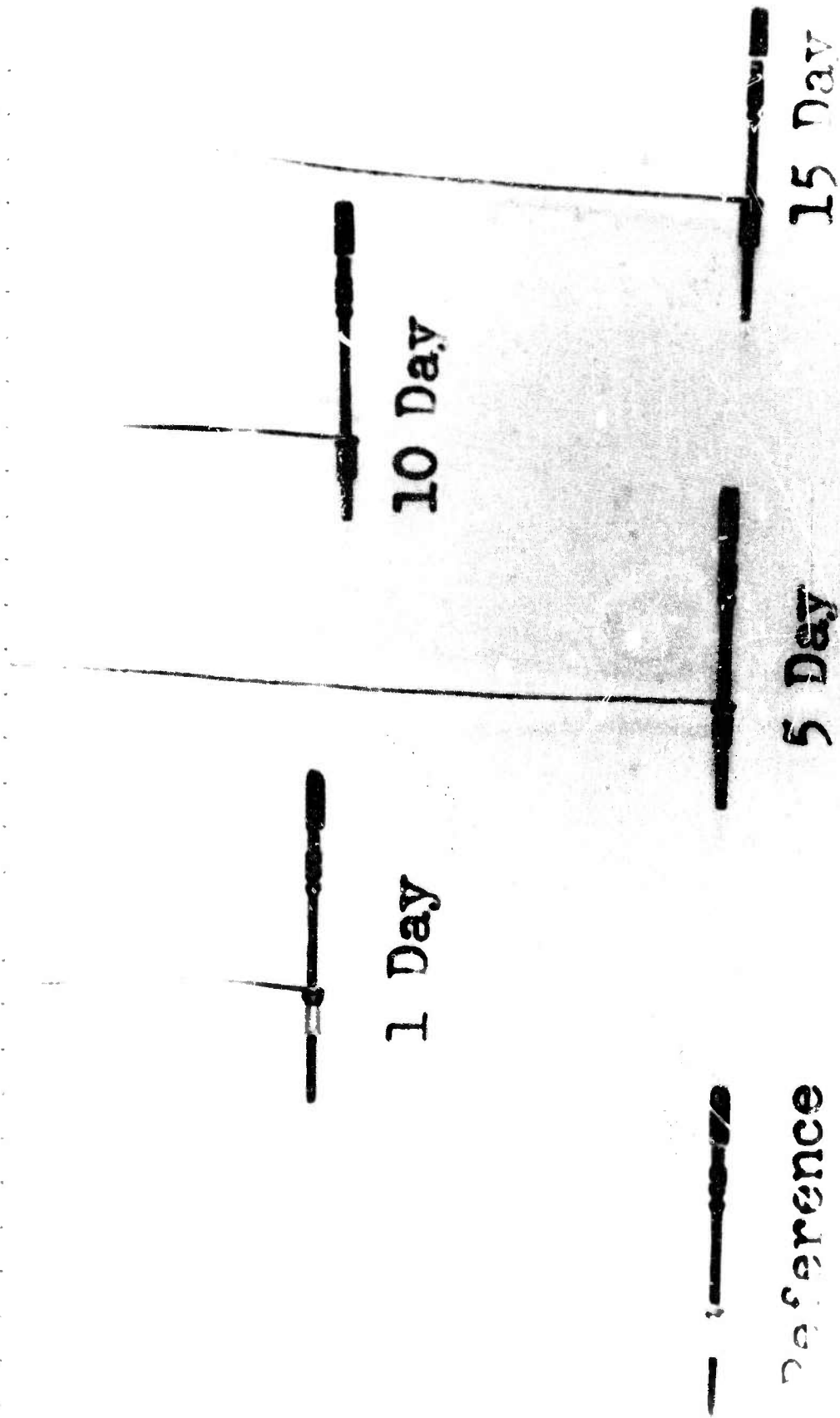

Photograph 1

Corrosion of Silver Plated Wire
During 200 C Temperature Exposure

Post rewrapped 25 times -
Shown following exposure
to 200°C

Rewrapped 25 times - No temp.
exposure

Post rewrapped 10 times -
Shown following exposure
to 200°C

Rewrapped 10 times - No temp.
exposure

Disturbed wrap - Shown
following exposure to 200°C

Disturbed wrap - No temp.
exposure

Virgin wrap - Shown
following exposure

Note - Marginal gas tightness
Under Disturbed Wraps
Shown Following Exposure
to 200°C

Photo 2

Gas Tight
Center

64

To: [unclear]
Shown following exposure to 200°C

Rewrapped 25 times - No temp. exposure

Post rewrapped 10 times - Shown following exposure to 200°C

Rewrapped 10 times - No temp. exposure

Disturbed wrap - Shown following exposure to 200°C

Disturbed wrap - No temp. exposure

Virgin wrap - Shown following exposure to 200°C

Virgin wrap - No temp. exposure

Note - Marginal Gas Tight Area Under Disturbed Wraps Shown Following Exposure to 200°C

Photograph 3

Consists of #30 AWG
Gas Tight
Bezelium Copper

100% Virgin wrap - No temp.
exposure to 200°C

Rewrapped 25 times - No temp.
exposure

50% Virgin wrap - No temp.
exposure to 200°C

Post rewrapped 10 times -
Shown following exposure
to 200°C

Rewrapped 10 times - No temp.
exposure

Disturbed wrap - Shown
following exposure to 200°C

Disturbed wrap - No temp.
exposure

Virgin wrap - Shown
following exposure to 200°C

50% Virgin wrap - No temp.
exposure

Virgin wrap - No temp.
exposure

Post rewrapped 25 times -
Shown following exposure
to 200°C

Rewrapped 25 times - No temp.
exposure

Rewrapped wrap - Shown
following exposure to 200°C

Rewrapped wrap - No temp.
exposure

Virgin wrap - Shown
following exposure to 200°C

Virgin wrap - No temp.
exposure

Note - Silver Plating from Wire
Adhering to Wireposts Shown
Following Exposure to 200°C

Micrograph 7

Wireposts of #26 AWG
Half-Hard Brass

Revised 2/11/68
Tom

Revised 2/11/68
Tom

Discharged Army Follow-up 0

Disturbed Man - New York

Virgin Man Follow-up 0

Revised 2/11/68
Tom

Note - Brackets Used to Clamp
Connector Plates to
Vibration Fixture

Photograph 9
Wire-wrap Fixture Used During
Initial Vibration Exposure



Insulated wraps of #30 AWG wire
loosened during vibration

#25 AWG wires appear to be tightly
wrapped following vibration

Broken #30 AWG wire at the start
of the insulated portion of the wrap

Broken #30 AWG wire at a bend in
the lead routing

#30 AWG wire in which insulated wrap
loosened allowing a break to occur
in the first turn of bare wrap

Photograph 10

Typical Damage Incurred During
Initial Vibration Test

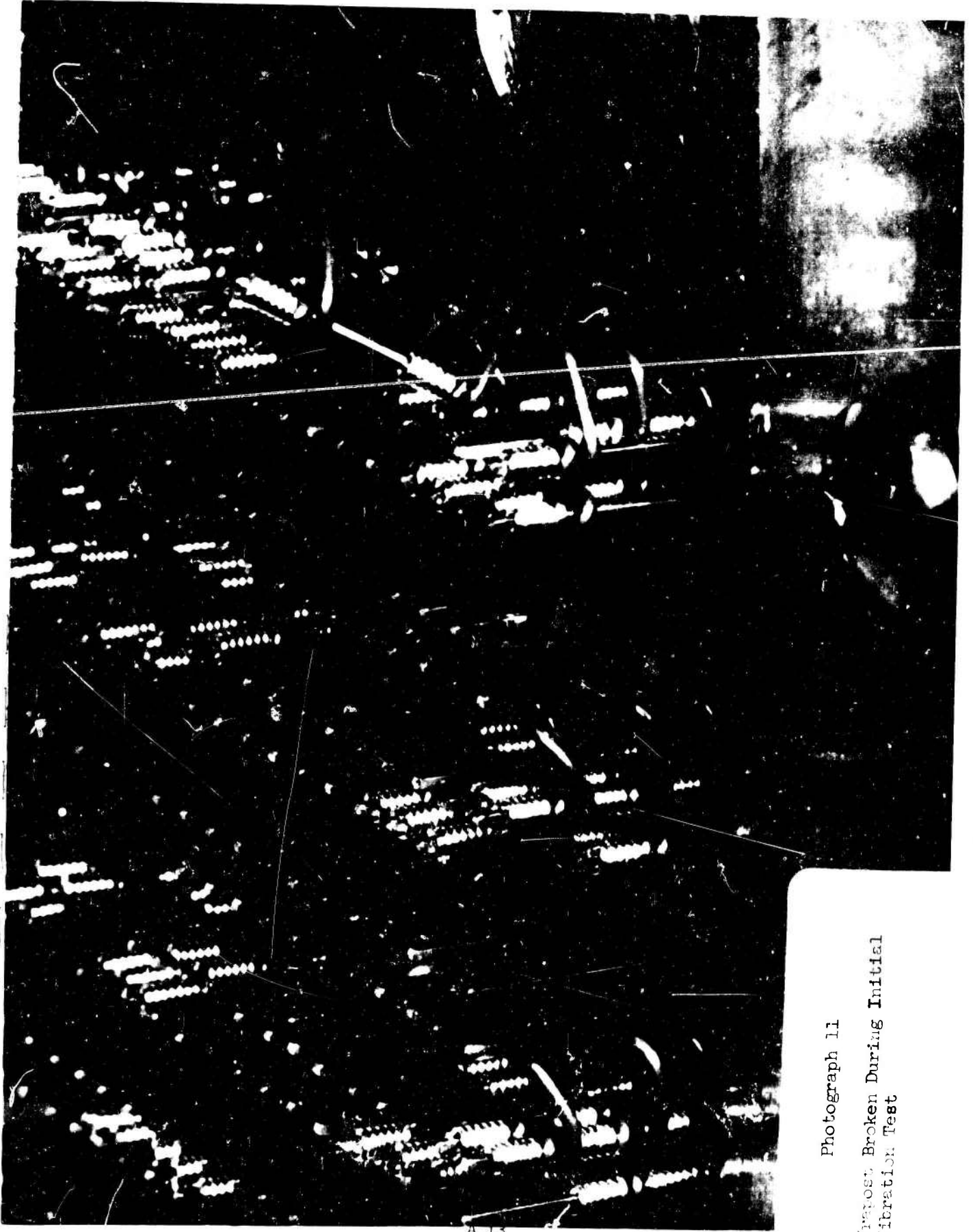

Photograph 11

Wires Broken During Initial
Vibration Test

A.13

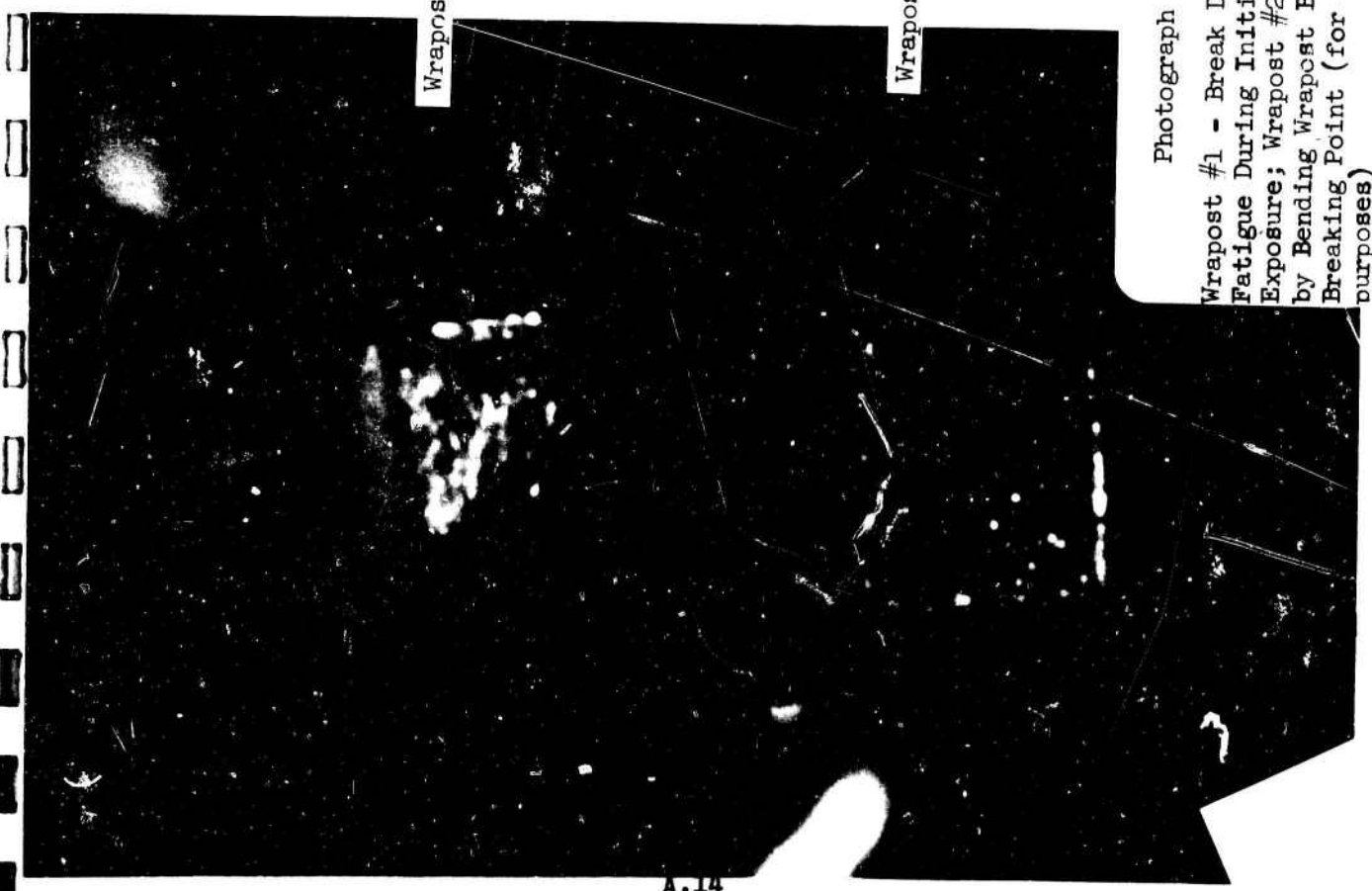
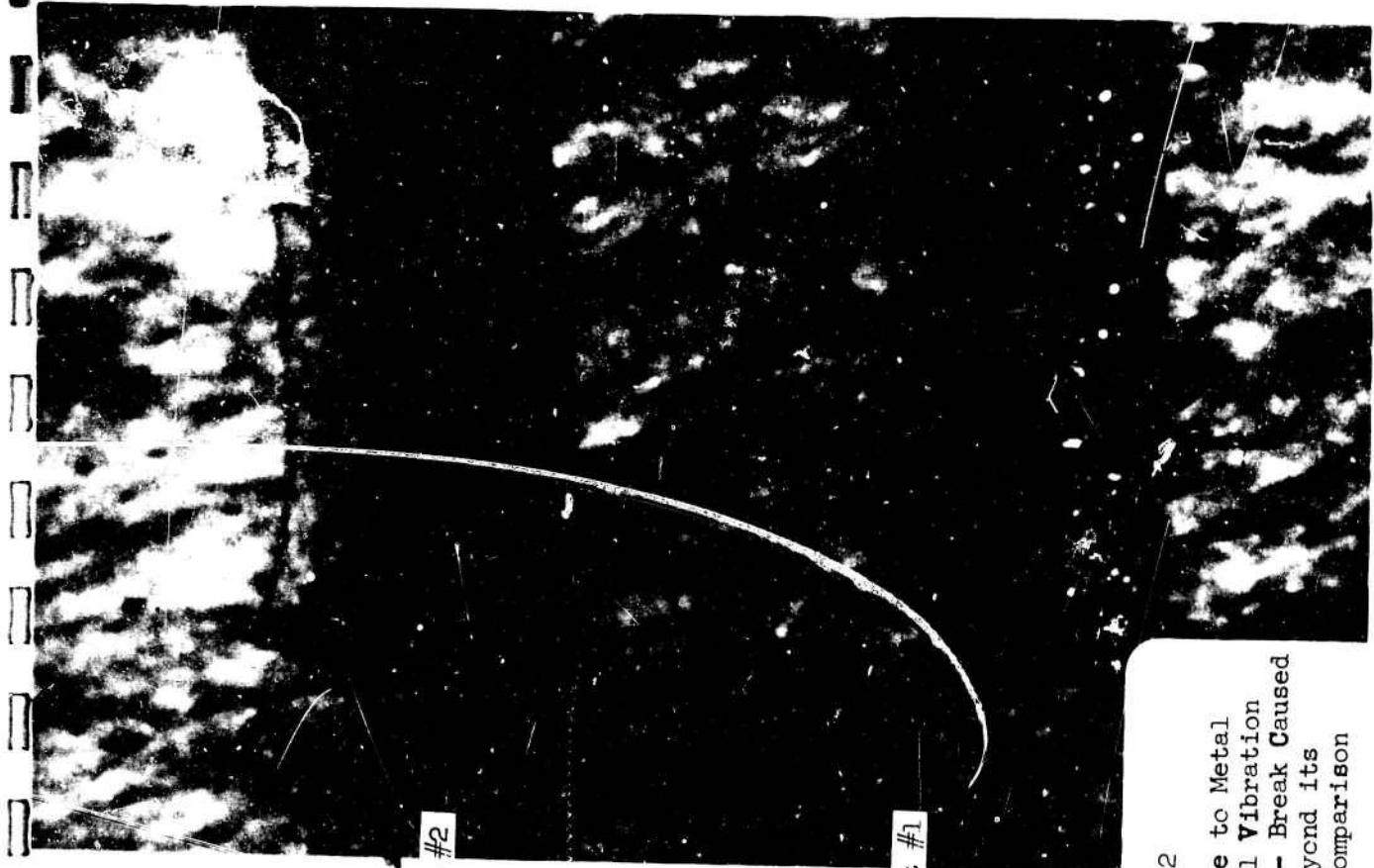

Photograph 12
Wrapost #1 - Break Due to Metal Fatigue During Initial Vibration Exposure; Wrapost #2 - Break Caused by Bending Wrapost Beyond its Breaking Point (for comparison purposes)

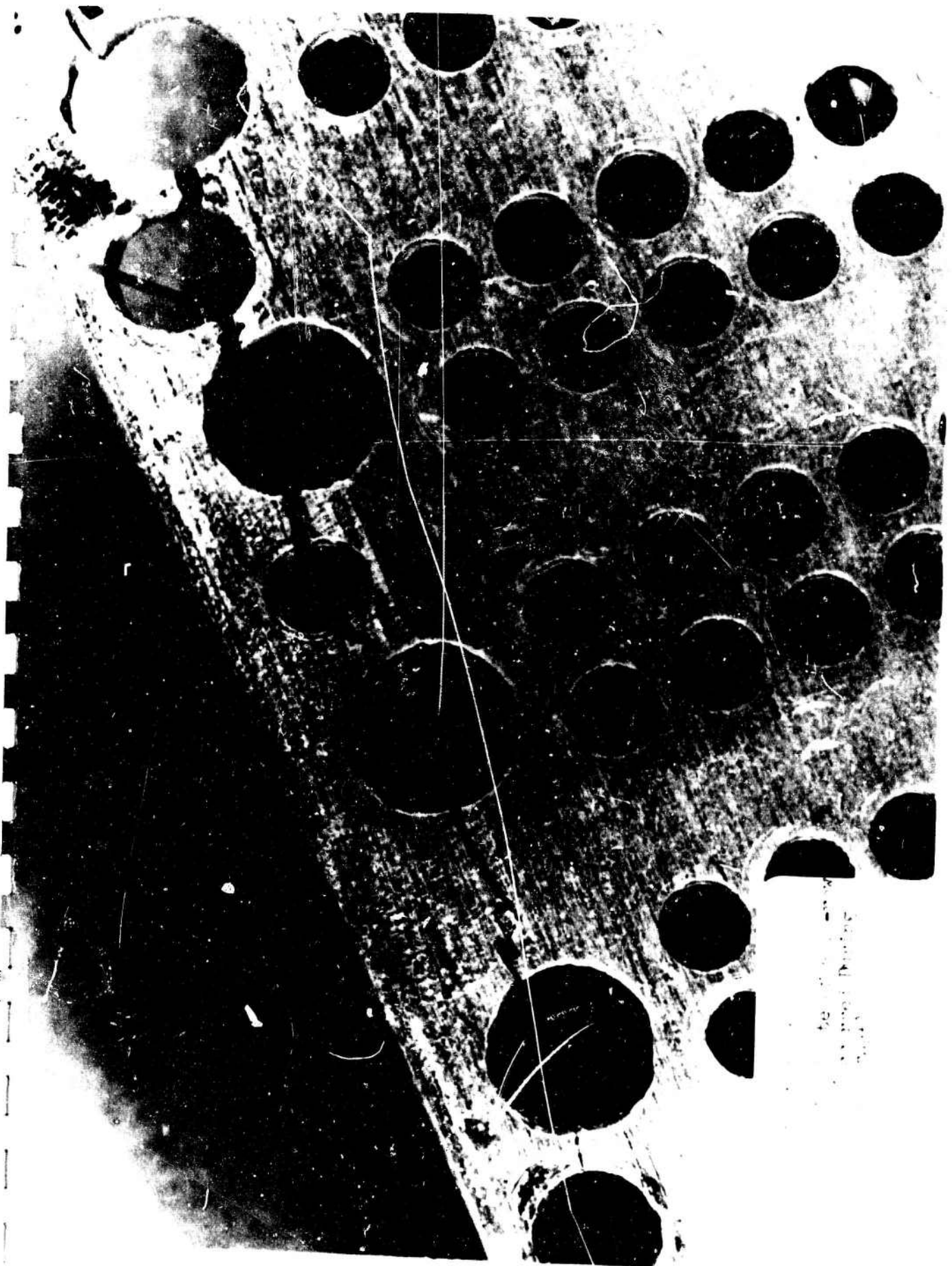

Director Plates Mounted
on Screws



Plate 14

Plate 14
Used in the
Tight



Type - Insert Headers in 10-row
Cone and Give the Headers
Type 3 Module Header

Photograph 15
Type 3 Module Headers Mounted
in a 10-row Connector Plate

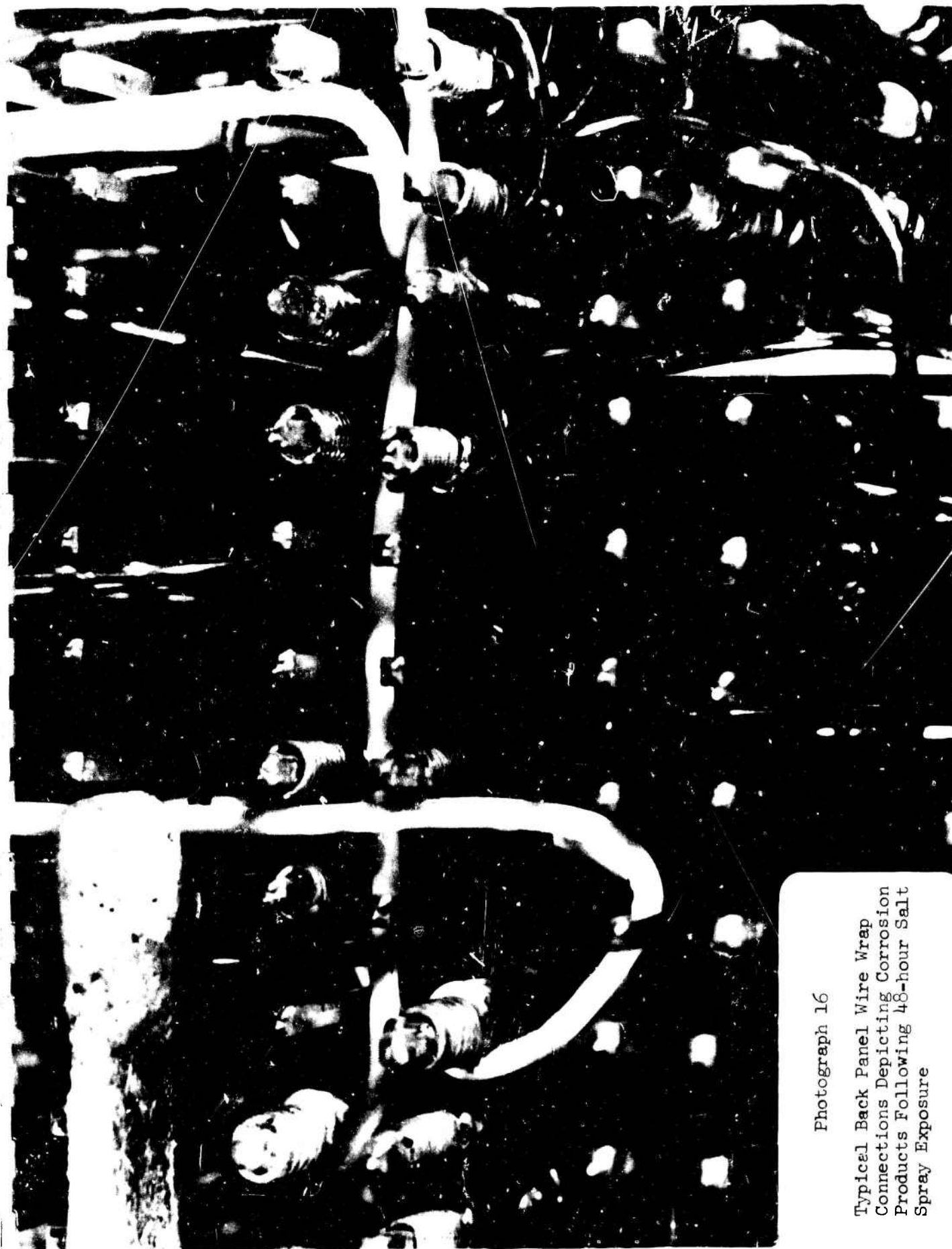

Photograph 16

Typical Back Panel Wire Wrap
Connections Depicting Corrosion
Products Following 48-hour Salt
Spray Exposure

APPENDIX B

ILLUSTRATIONS

	Page No.
Figure 1 - Strip Force Test Fixture	B.2
Figure 2 - Wrapper Resistance Test Setup	B.3
Figure 3 - Connector Plate Mounting During Initial Vibration Test	B.4
Figure 4 - Connector Plate and Type 3 Module Header Mounting During Second Vibration Test	B.4

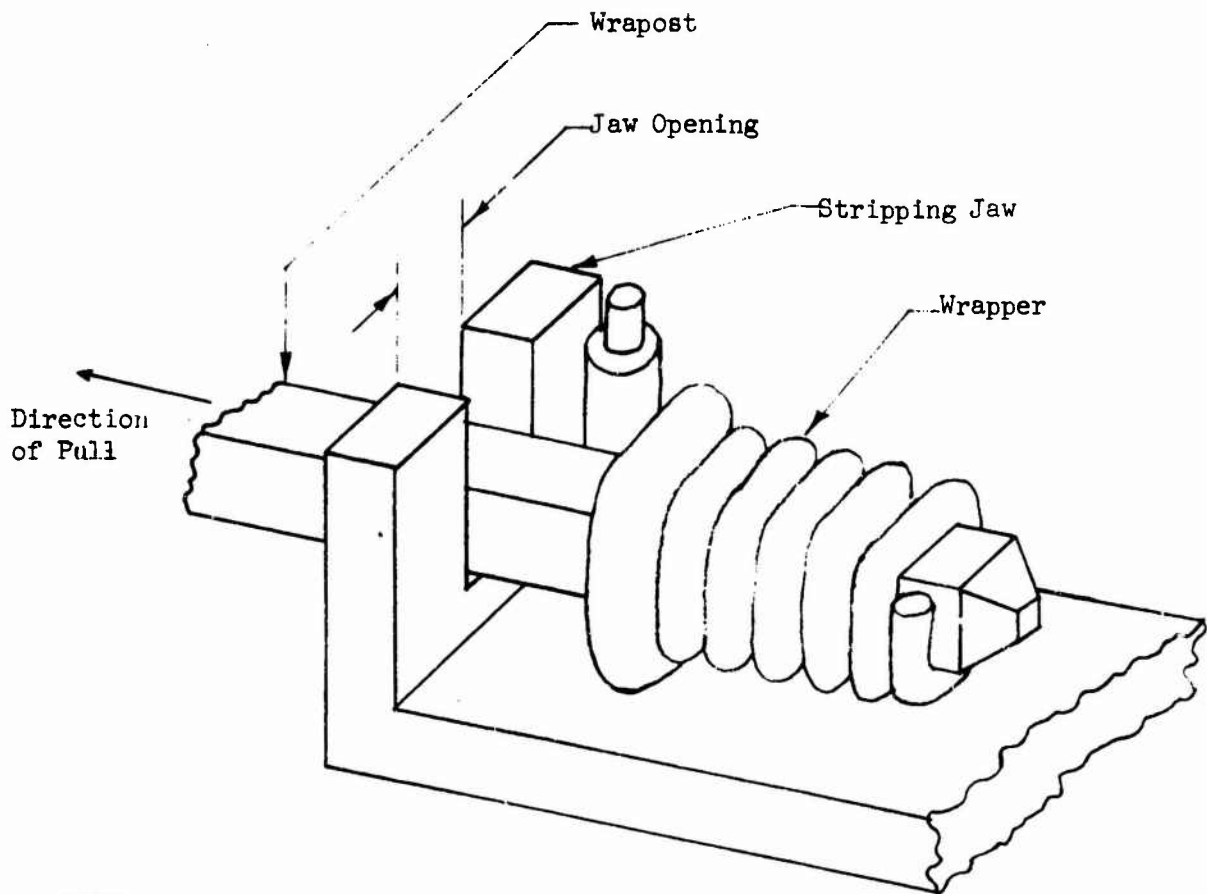

NOTE:

1. The stripping jaw shall engage at right angles to axis of the wrapost.
2. The maximum total clearance between jaw opening and wrapost shall be $0.7 \times$ diameter of wire.
3. When the wrapost and stripping fixture are properly aligned, the clearance shall be such that there is no binding or wedging between jaw and wrapper.
4. Both sides of the stripping jaw shall be in the same plane, creating a flat surface contact with the wire on either side of the wrapost.

Figure 1

Strip Force Test Fixture

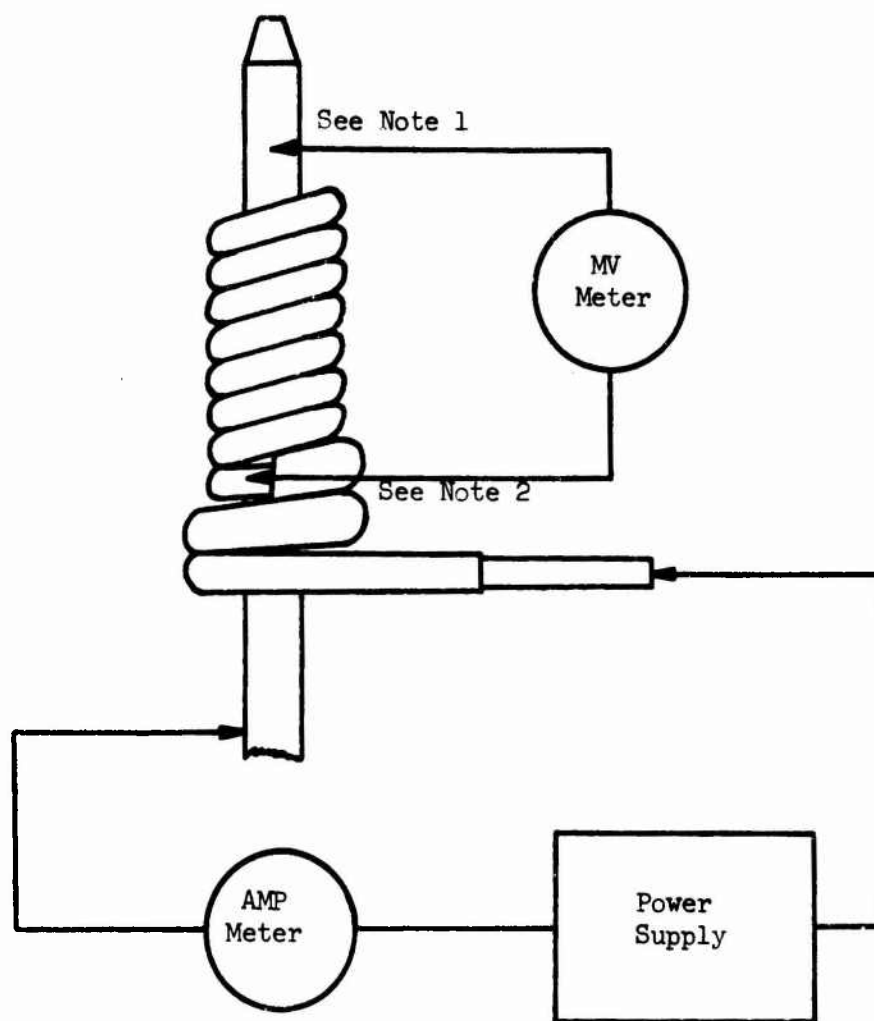

NOTES:

1. This probe shall not touch the wire.
2. This probe shall be placed on the first turn of uninsulated wire.

Figure 2
Wrapper Resistance Test Setup

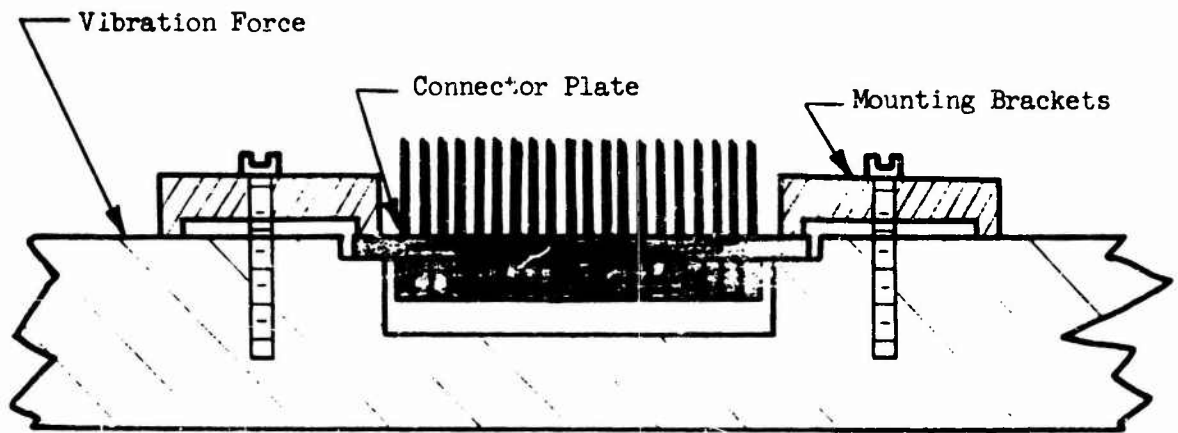

Figure 3

Connector Plate Mounting During Initial Vibration Test

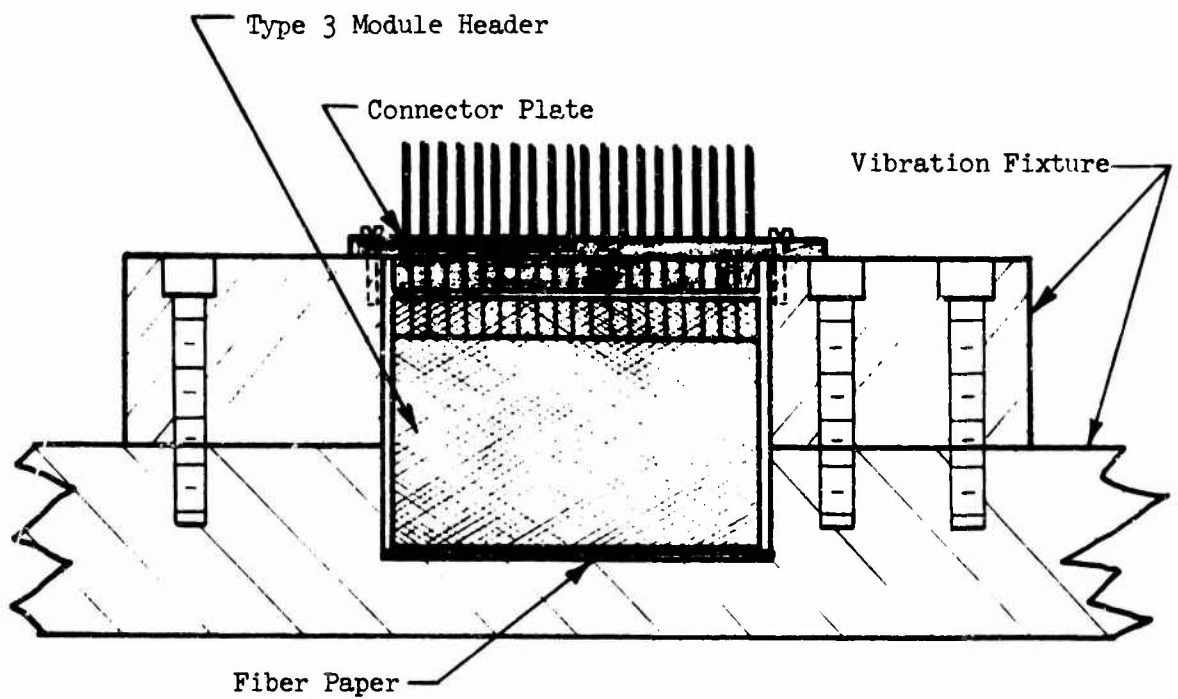

Figure 4

Connector Plate and Type 3 Module Header Mounting
During Second Vibration Test

NAFI TR-1242

APPENDIX C

Graphs of Temperature-Strip-Force Characteristics

Graph 1

Strip Force Characteristics of Wire-Wrap Connections at Room Ambient Temperature During First 10 Consecutive Days Following Fabrication. Sample Connections Consist of #26 AWG OFHC Copper Wire Wrapped on Beryllium Copper Wraposts.

MINOR FORCE IN POUNDS

Legend

- Minimum Limits of WS-6119
- △ — Virgin Wraps
- — Disturbed Wraps

TEST PERIOD IN DAYS

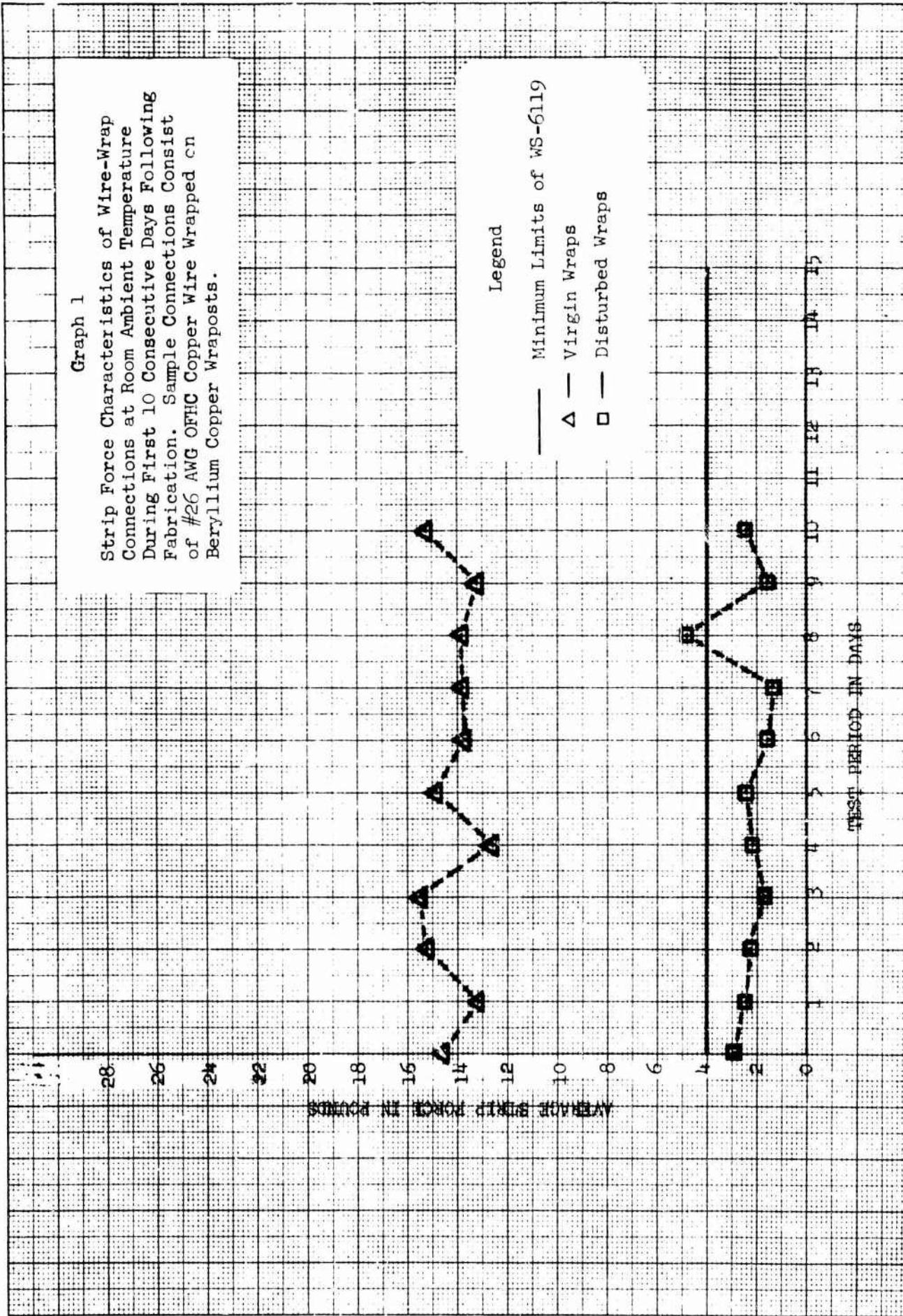

Graph 2

Strip Force Characteristics of Wire-Wrap Connections at Room Ambient Temperature During First 10 Consecutive Days Following Fabrication. Sample Connections Consist of #30 AWG OFHC Copper Wire Wrapped on Beryllium Copper Wraposts.

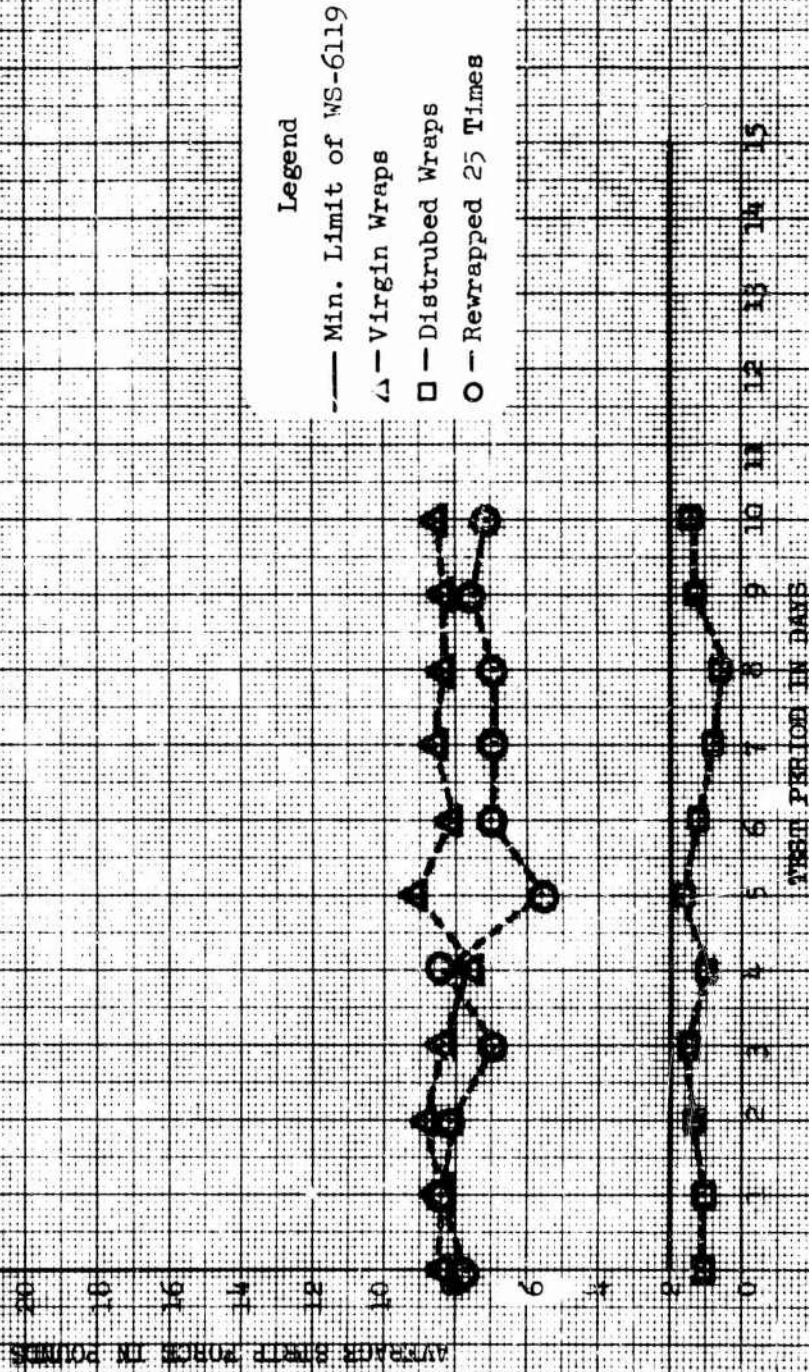

Legend

- Min. Limit of WS-6119
- △ - Virgin Wraps
- - Distrubed Wraps
- - Rewrapped 25 Times

Graph 3

Effect of 105°C Temperature Exposure on Strip Force Characteristics of Wire-Wrap Connections of #26 AWG OFHC Copper Wire and #30 AWG Alloy Wire on Beryllium Copper Wraposts.

AVERAGE STRIP FORCE IN POUNDS

LENGTH OF TEMPERATURE EXPOSURE IN HOURS

Legend

- #26 AWG Min. Limit of WS-6119
- #30 AWG Min. Limit of WS-6119
- O- #26 AWG Virgin Wraps
- Δ- #30 AWG Virgin Wraps

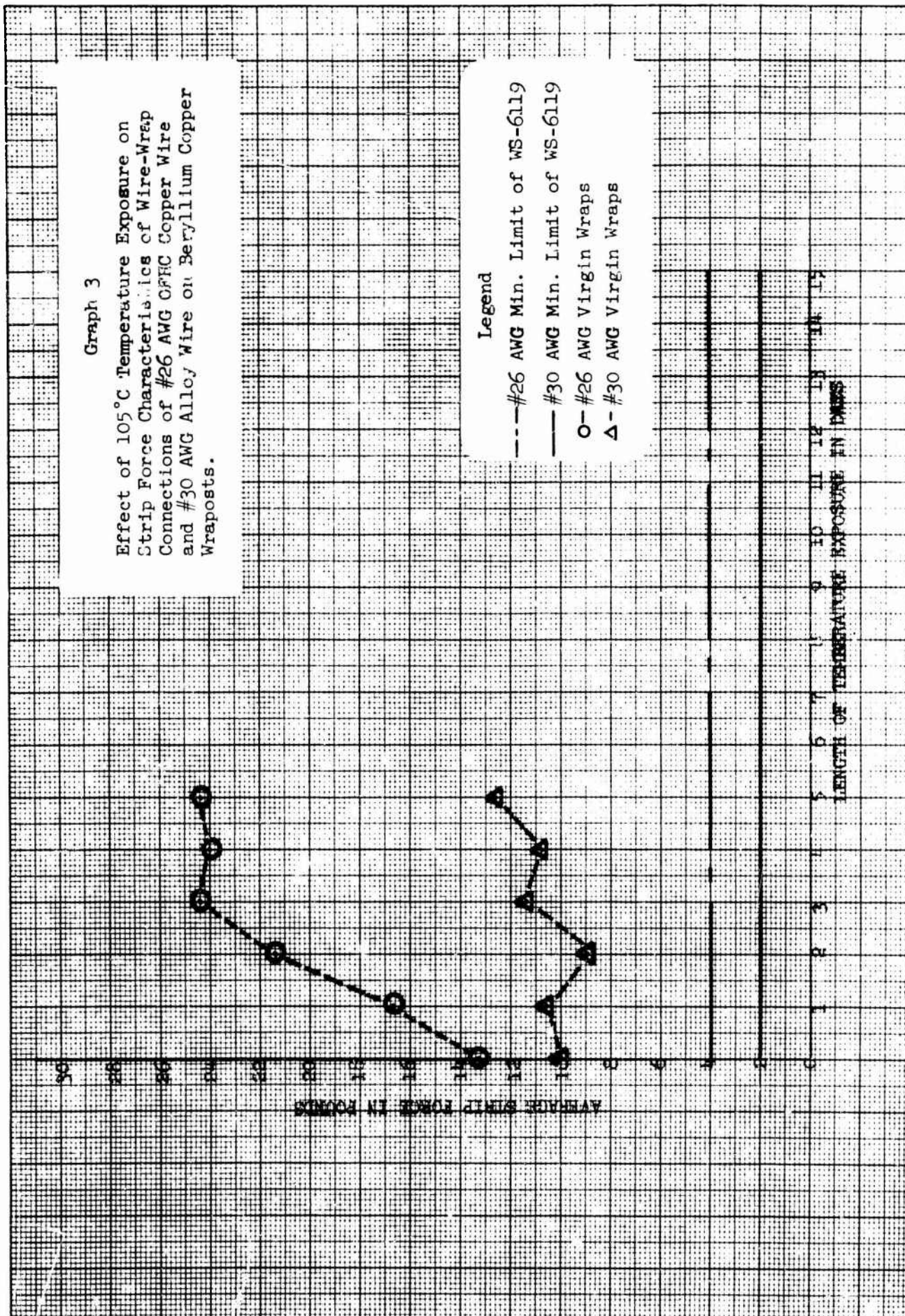

Graph 4

Effect of 150°C Temperature Exposure on Strip Force Characteristics of Wire-Wrap Connections Wrapped with #26 AWG Copper Wire on Beryllium Copper Wraposts.

Legend

- Minimum Limits of WS-6119
- △ — Virgin Wraps
- — Disturbed Wraps
- — Rewrapped 25 Times

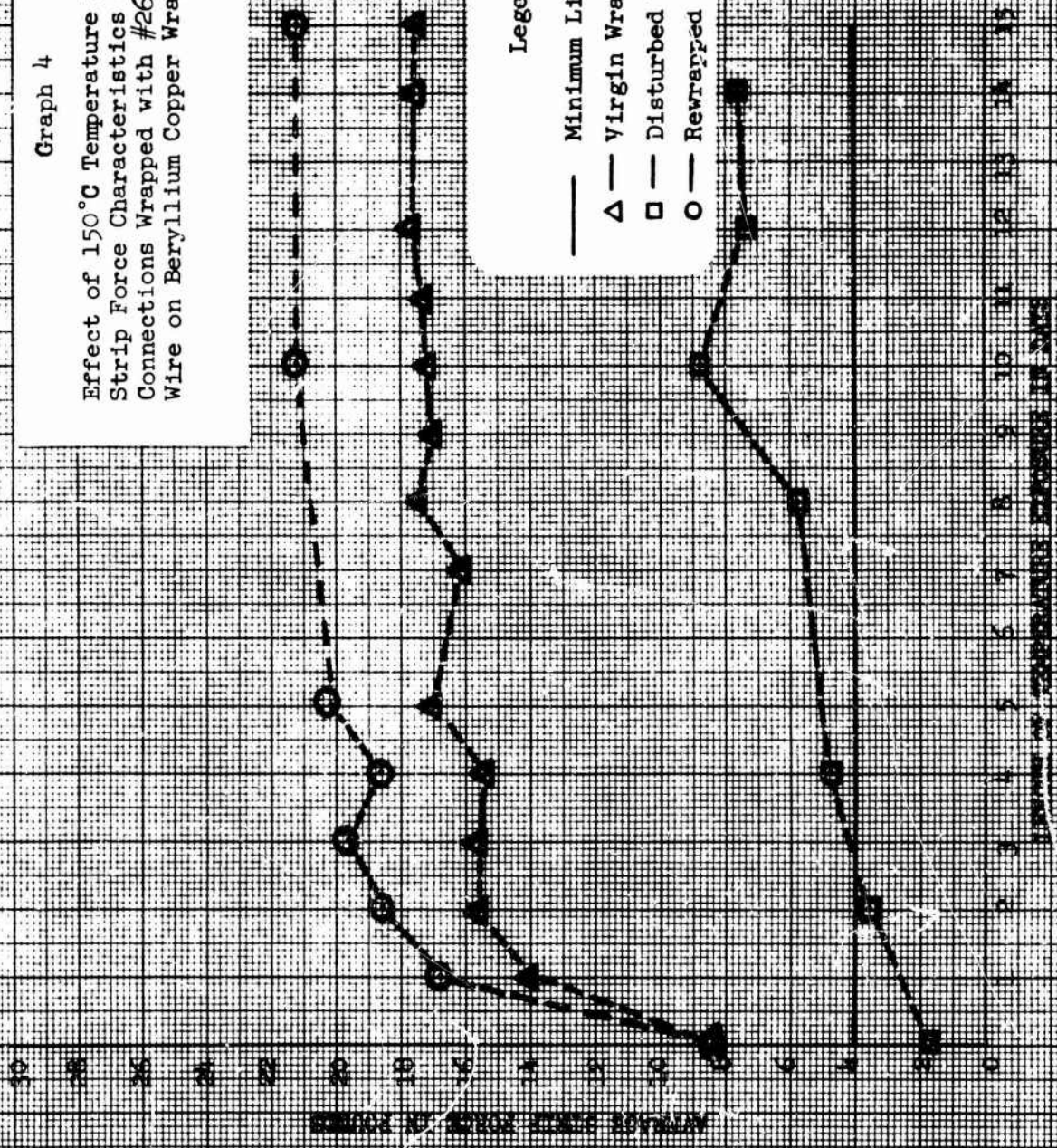

Graph 5

Effect of 150°C Temperature Exposure on Strip Force Characteristics of Wire-Wrap Connections Wrapped with #30 AWG OFHC Copper Wire on Beryllium Copper Wraposts.

Legend

— Min. Limit of WS-6119

Δ-Virgin Wraps

□-Disturbed Wraps

O--Rewrapped 25 Times

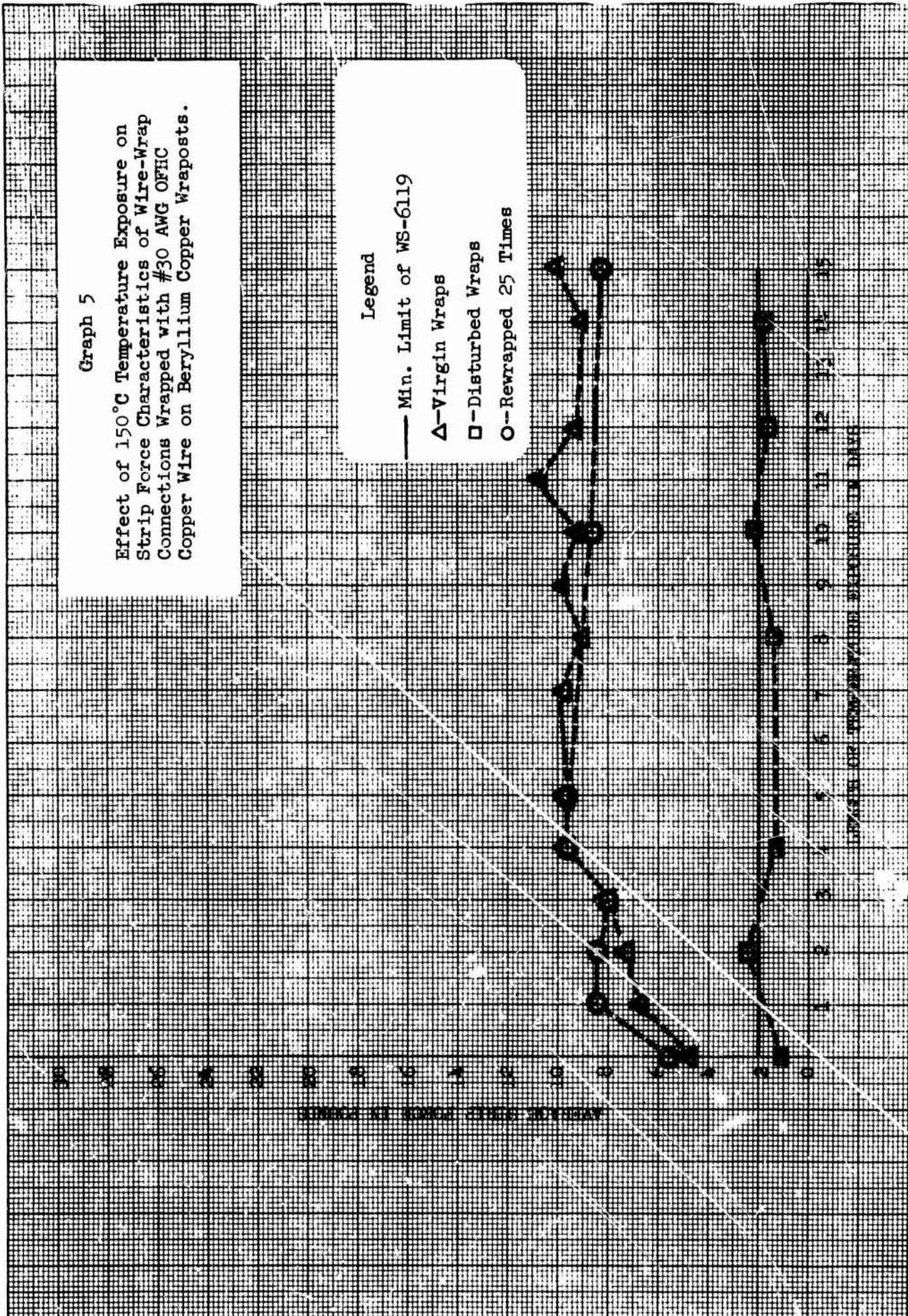

Graph 6

Effect of 200°C Temperature Exposure on Strip Force Characteristics of Wire-Wrap Connections Wrapped with #26 AWG OFHC Copper Wire on Beryllium Copper Wraposts.

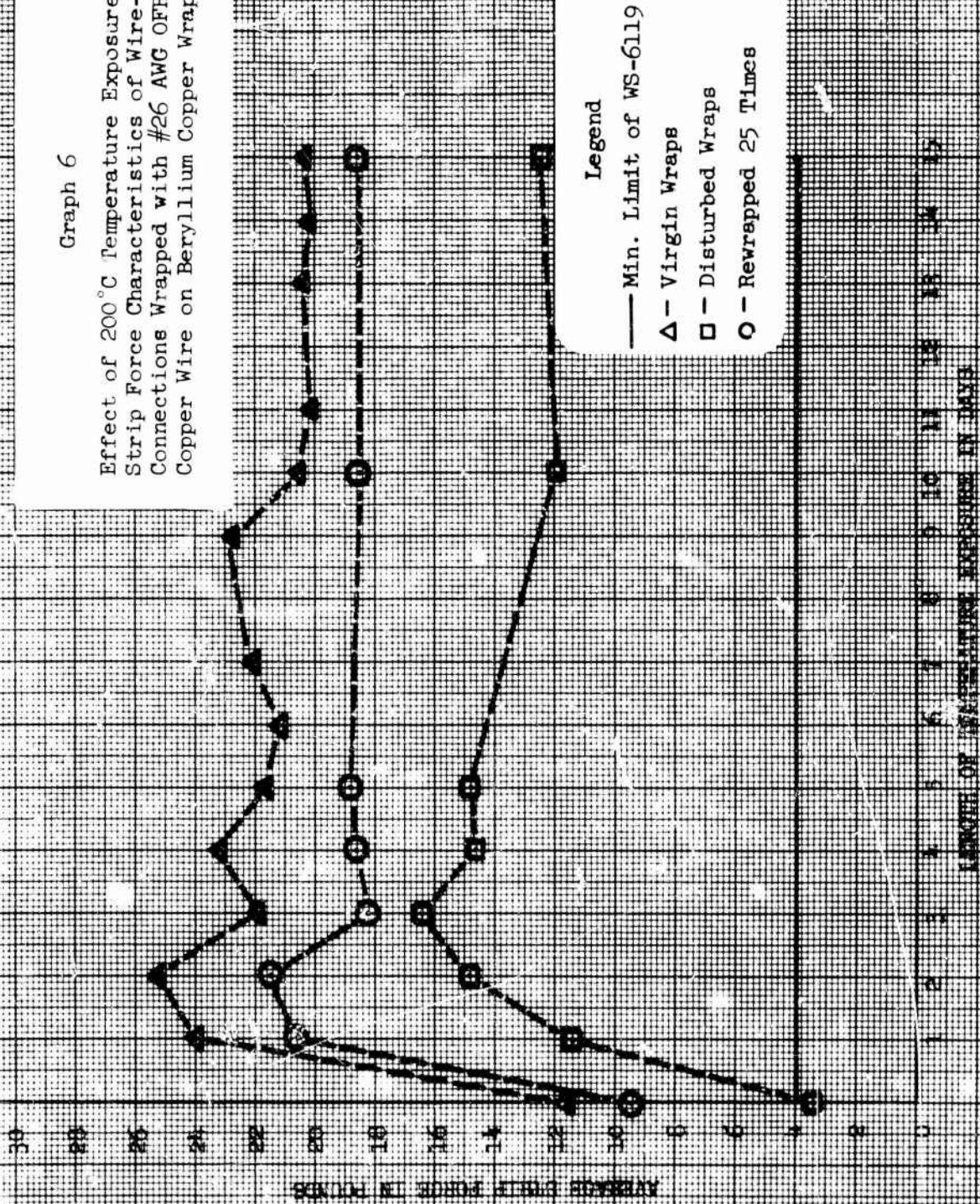

Legend

- Min. Limit of WS-6119
- Δ - Virgin Wraps
- - Disturbed Wraps
- - Rewrapped 25 Times

Graph 7

Effect of 200°C Temperature Exposure on Strip Force Characteristics of Wire-Wrap Connections with #30 AWG OFHC Copper Wire on Beryllium Copper Wrapposts.

- Legend
- Min. Limit of WS-6119
 - △—Virgin Wraps
 - Disturbed Wraps
 - Rewrapped 25 Times

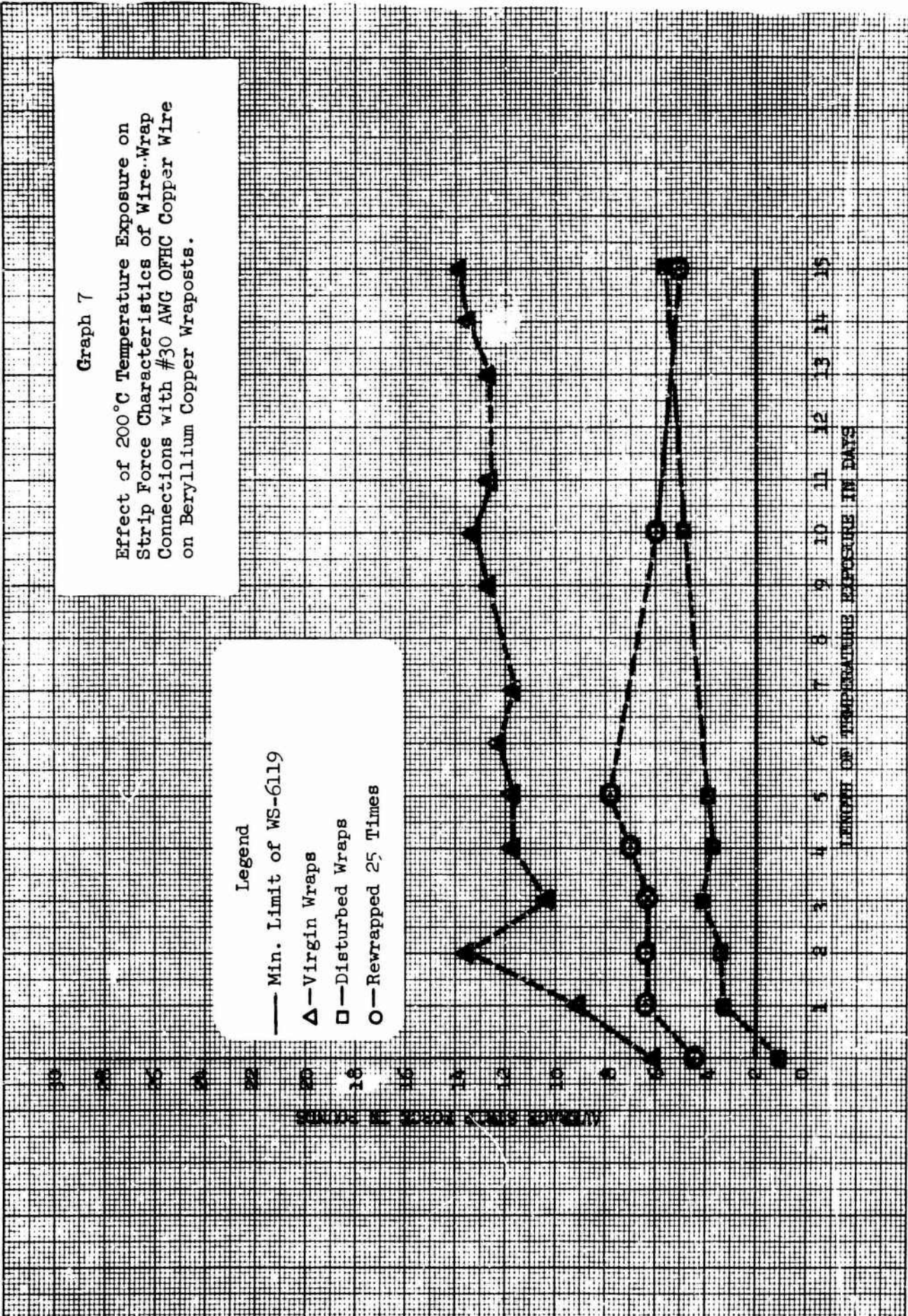

Graph 8

Effect of 200°C Temperature Exposure on Strip Force Characteristics of Wire-Wrap Connections Wrapped with #26 AWG OFHC Copper Wire on Half-Hard Brass Wraposts.

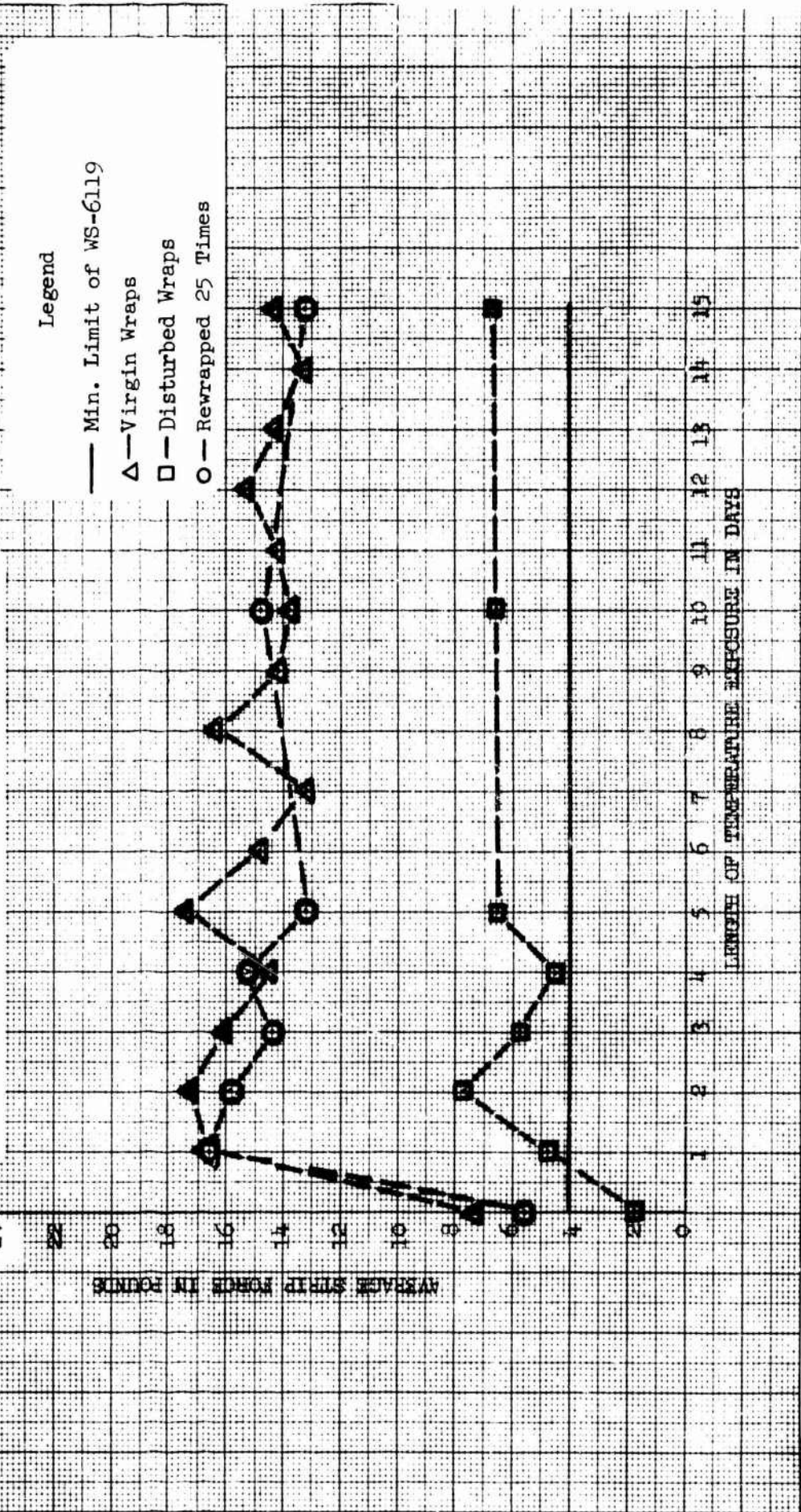

Graph 9

Effect of 200 °C Temperature Exposure on Strip Force Characteristics of Wire-Wrap Connections Wrapped with #30 AWG OFHC Copper Wire on Half-Hard Brass Wraposts.

Legend
— Min. Limit of WS-6119
△— Virgin Wraps
□— Disturbed Wraps
○— Rewrapped 25 Times

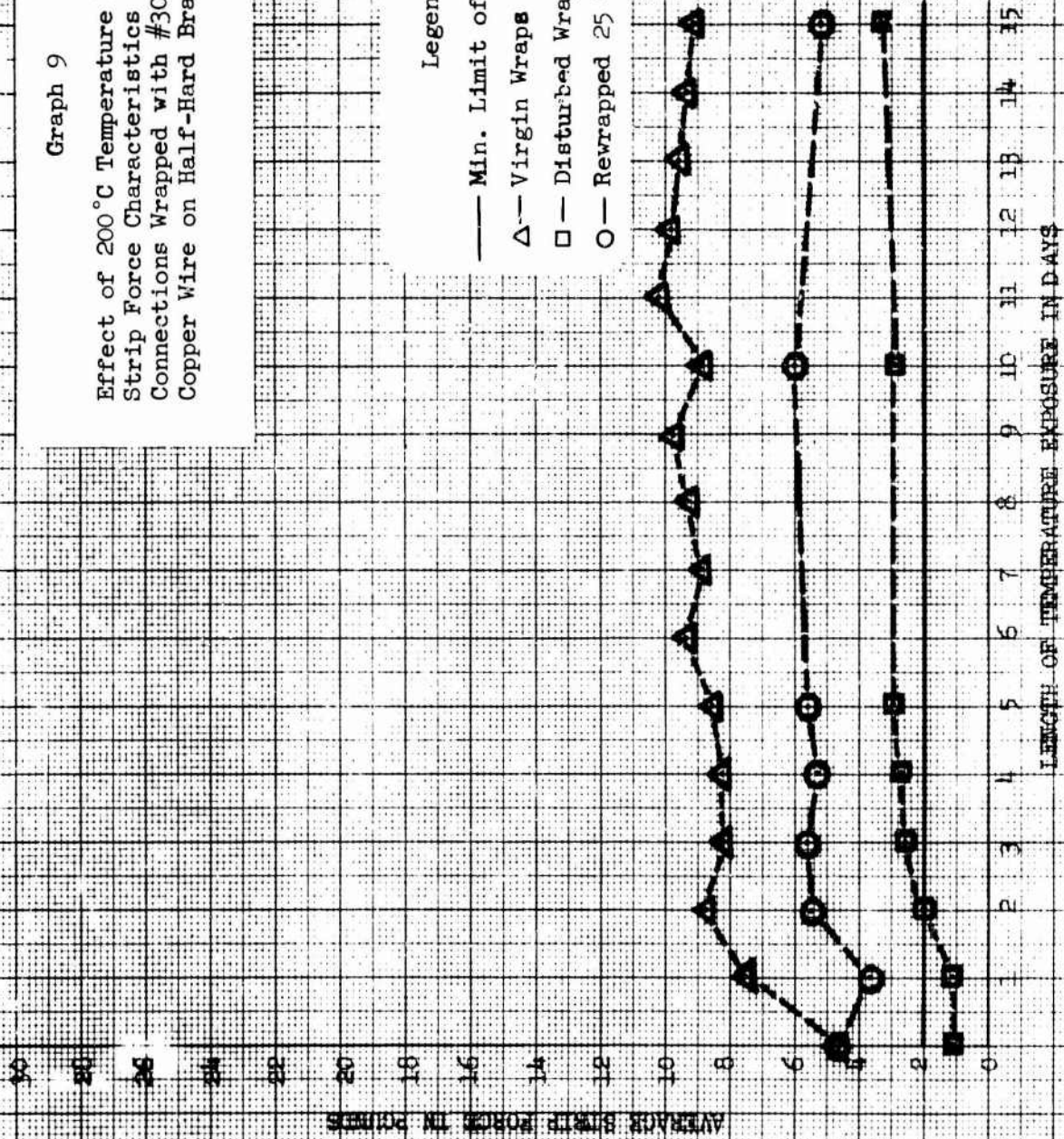

UNCLASSIFIED

Security Classification

DOCUMENT CONTROL DATA - R&D		
<i>(Security classification of title, body of abstract and indexing annotation must be entered when the overall report is classified)</i>		
1 ORIGINATING ACTIVITY (Corporate author) Naval Avionics Facility Indianapolis, Indiana 46218		2a REPORT SECURITY CLASSIFICATION UNCLASSIFIED
		2b GROUP
3 REPORT TITLE Final Report of Exploratory Environmental Evaluation of Solderless Wrapped Connections, Fabricated by the Naval Avionics Facility, Indianapolis, Indiana		
4 DESCRIPTIVE NOTES (Type of report and inclusive dates) Technical Evaluation Report		
5 AUTHOR(S) (Last name, first name, initial) Davis, Orville E.		
6. REPORT DATE 31 January 1969	7a. TOTAL NO. OF PAGES 86	7b. NO. OF REFS None
8a. CONTRACT OR GRANT NO. WR-7-0040 A/C 30009 b. PROJECT NO. TA 38402 c. F553 d. 67-2-8ER	9a. ORIGINATOR'S REPORT NUMBER(S) TR-1242	
		9b. OTHER REPORT NO(S) (Any other numbers that may be assigned this report) None
10. AVAILABILITY/LIMITATION NOTICES QUALIFIED REQUESTERS MAY OBTAIN COPIES OF THE REPORT DIRECT FROM DDC.		
11. SUPPLEMENTARY NOTES	12. SPONSORING MILITARY ACTIVITY Naval Avionics Facility (NAFI) Engineering Division 920	
13 ABSTRACT: The solderless wrapped connection (or wire wrap connection) is finding extensive use in both commercial and military electrical and electronic equipments. Wire wrapping is a technique for electrically and mechanically connecting a solid conductor to a terminal by wrapping a specified number of turns of wire, under tension, around a terminal having two or more sharp edges. The increasing use of the solderless wrapped connection as a wiring technique is accompanied by an increasing need for a comprehensive evaluation of the wrapped connection to determine its performance capabilities under a wide spectrum of environmental states, including those encountered under both ground and aerospace conditions. As a step in fulfilling this need, the Product Evaluation Branch of Naval Avionics Facility, Indianapolis (NAFI), Indiana conducted an Exploratory Environmental Evaluation Program designed to establish environmental capabilities of wire wrap connections with respect to temperature, vibration and salt spray exposures, and to provide designers and users with some guidelines for wire wrap application in military systems. Although basic test procedures and environmental limits were developed around existing military specifications, the severity of these tests, both in duration and environmental extremes, was extended well beyond the requirements of these specifications. This was done in an effort to explore wire wrap characteristics under conditions far more extreme than those presently specified for wrapped connections and to possibly establish ultimate capabilities. ←		

Security Classification

14 KEY WORDS	LINK A		LINK B		LINK C	
	ROLE	WT	ROLE	WT	ROLE	WT
1. Solderless connections						
2. Wire Wrap						
3. Standard Hardware Program (SHP)						
4. Back Panel Wiring						

INSTRUCTIONS

1. **ORIGINATING ACTIVITY:** Enter the name and address of the contractor, subcontractor, grantee, Department of Defense activity or other organization (*corporate author*) issuing the report.
- 2a. **REPORT SECURITY CLASSIFICATION:** Enter the overall security classification of the report. Indicate whether "Restricted Data" is included. Marking is to be in accordance with appropriate security regulations.
- 2b. **GROUP:** Automatic downgrading is specified in DoD Directive 5200.10 and Armed Forces Industrial Manual. Enter the group number. Also, when applicable, show that optional markings have been used for Group 3 and Group 4 as authorized.
3. **REPORT TITLE:** Enter the complete report title in all capital letters. Titles in all cases should be unclassified. If a meaningful title cannot be selected without classification, show title classification in all capitals in parenthesis immediately following the title.
4. **DESCRIPTIVE NOTES:** If appropriate, enter the type of report, e.g., interim, progress, summary, annual, or final. Give the inclusive dates when a specific reporting period is covered.
5. **AUTHOR(S):** Enter the name(s) of author(s) as shown on or in the report. Enter last name, first name, middle initial. If military, show rank and branch of service. The name of the principal author is an absolute minimum requirement.
6. **REPORT DATE:** Enter the date of the report as day, month, year, or month, year. If more than one date appears on the report, use date of publication.
- 7a. **TOTAL NUMBER OF PAGES:** The total page count should follow normal pagination procedures, i.e., enter the number of pages containing information.
- 7b. **NUMBER OF REFERENCES:** Enter the total number of references cited in the report.
- 8a. **CONTRACT OR GRANT NUMBER:** If appropriate, enter the applicable number of the contract or grant under which the report was written.
- 8b, 8c, & 8d. **PROJECT NUMBER:** Enter the appropriate military department identification, such as project number, subproject number, system numbers, task number, etc.
- 9a. **ORIGINATOR'S REPORT NUMBER(S):** Enter the official report number by which the document will be identified and controlled by the originating activity. This number must be unique to this report.
- 9b. **OTHER REPORT NUMBER(S):** If the report has been assigned any other report numbers (*either by the originator or by the sponsor*), also enter this number(s).
10. **AVAILABILITY/LIMITATION NOTICES:** Enter any limitations on further dissemination of the report, other than those

imposed by security classification, using standard statements such as:

- (1) "Qualified requesters may obtain copies of this report from DDC."
- (2) "Foreign announcement and dissemination of this report by DDC is not authorized."
- (3) "U. S. Government agencies may obtain copies of this report directly from DDC. Other qualified DDC users shall request through _____."
- (4) "U. S. military agencies may obtain copies of this report directly from DDC. Other qualified users shall request through _____."
- (5) "All distribution of this report is controlled. Qualified DDC users shall request through _____."

If the report has been furnished to the Office of Technical Services, Department of Commerce, for sale to the public, indicate this fact and enter the price, if known.

11. **SUPPLEMENTARY NOTES:** Use for additional explanatory notes.

12. **SPONSORING MILITARY ACTIVITY:** Enter the name of the departmental project office or laboratory sponsoring (*paying for*) the research and development. Include address.

13. **ABSTRACT:** Enter an abstract giving a brief and factual summary of the document indicative of the report, even though it may also appear elsewhere in the body of the technical report. If additional space is required, a continuation sheet shall be attached.

It is highly desirable that the abstract of classified reports be unclassified. Each paragraph of the abstract shall end with an indication of the military security classification of the information in the paragraph, represented as (TS), (S), (C), or (U).

There is no limitation on the length of the abstract. However, the suggested length is from 150 to 225 words.

14. **KEY WORDS:** Key words are technically meaningful terms or short phrases that characterize a report and may be used as index entries for cataloging the report. Key words must be selected so that no security classification is required. Identifiers, such as equipment model designation, trade name, military project code name, geographic location, may be used as key words but will be followed by an indication of technical context. The assignment of links, roles, and weights is optional.