

**AD 690169**

# **TECHNICAL REPORT**

**CAL No. VJ-2330-G-3**

## **SUMMARY REPORT ON OFF-ROAD MOBILITY RESEARCH**

**Volume I**

**3rd TECHNICAL REPORT  
NOVEMBER 1968**

**Sponsored by:**

**Advanced Research Projects Agency  
Department of Defense  
ARPA Order No. 841  
Dated 7 May 1966**

**Under Contract DAHC04 67 C 0005  
U.S. Army Research Office - Durham  
Durham, N.C.**

**Distribution of this document is unlimited.**



**CORNELL AERONAUTICAL LABORATORY, INC.**

**OF CORNELL UNIVERSITY, BUFFALO, N. Y. 14221**

Reproduced by the  
**CLEARINGHOUSE**  
for Federal Scientific & Technical  
Information Springfield Va. 22151

# DISCLAIMER NOTICE

THIS DOCUMENT IS THE BEST  
QUALITY AVAILABLE.

COPY FURNISHED CONTAINED  
A SIGNIFICANT NUMBER OF  
PAGES WHICH DO NOT  
REPRODUCE LEGIBLY.

ACCESSION for		
OFSTI	WHITE SECTION	←
DDG	BLUE SECTION	
UNANNOUNCED		
JUSTIFICATION		
BY		
DEFENSE RESPONSIBILITY CODES		
LEVEL and/or SPECIAL		
/		

THE FINDINGS IN THIS REPORT ARE NOT TO  
BE CONSTRUED AS AN OFFICIAL DEPARTMENT  
OF DEFENSE POSITION UNLESS SO DESIGNATED  
BY OTHER AUTHORIZED DOCUMENTS.



CORNELL AERONAUTICAL LABORATORY, INC.  
BUFFALO, NEW YORK 14221

CAL REPORT NO. VJ-2330-G-3

SUMMARY REPORT  
ON  
OFF-ROAD MOBILITY RESEARCH

3rd TECHNICAL REPORT

VOLUME I

UNDER CONTRACT DAHOC4 67 C 0005  
WITH  
U.S. ARMY RESEARCH OFFICE - DURHAM  
DURHAM, N.C.

NOVEMBER 1968

DISTRIBUTION OF THIS DOCUMENT IS UNLIMITED

Sponsored by:  
ADVANCED RESEARCH PROJECTS AGENCY  
DEPARTMENT OF DEFENSE  
ARPA ORDER NO. 841  
DATED 7 MAY 1966

This document has been approved  
for public release and sale; its  
distribution is unlimited.

JUL 13 1969

## ABSTRACT

A summary of research and engineering studies conducted on a long-range program of off-road mobility research is presented in Volume I of this two volume report. These studies, some of which are only partially completed, are directed at providing technical knowledge which is required to match off-road vehicles with military mobility requirements.

A hybrid computer model is described which will permit predicting vehicle dynamics performance of simulated vehicles traversing a broad spectrum of off-road situations. A critique of existing soil trafficability theories is made based on a review of the literature which treats the comparison of vehicle performance prediction with experimental results. Analytical and experimental studies of the velocity field and soil fabric in clay soil exposed to dynamic loads are summarized. A general method is discussed for processing mobility related environmental information and for mapping vehicle performance by computer methods. A concept is introduced for testing vehicles in relation to the total environment in order to define the vehicle performance envelope.

Also a method is introduced for displaying potential vehicle performance in selected geographic areas and for producing "testable" specifications for off-road vehicles. Engineering studies of an off-road driving simulator for synthesizing dynamic visual displays and vehicle motion in the laboratory are reviewed.

Recommendations pertaining to future off-road mobility research and engineering studies are presented.

Volume II contains Appendices that complement the material presented in Volume I.

## ACKNOWLEDGEMENT

This research was supported by the Advanced Research Projects Agency, Project AGILE, Department of Defense and was contracted through the U.S. Army Research Office, Durham under contract No. DAHC04 67 C 0005. The ARPA Technical Monitor was Mr. A. N. Tedesco. Mr. G. E. Bartlett was ORMR Program Manager.

This report was co-edited by:

George E. Bartlett  
Jerome N. Deutschman

The following sections were compiled from material prepared by the following Project Personnel:

- Section 3.2        Manfred R. Belsdorf, Richard Cassidy, Jerome N. Deutschman, Sol Kaufman, Richard L. Pleuthner, John H. Quirk, Dieter Schuring, Robert L. Smith, Rodolfo D. Vergara
- Section 3.3        Robert W. Coakley, Gregory Lewandowski, Richard P. Leonard, Thomas R. Magorian, H. T. McAdams, John H. Quirk, Walter F. Wood
- Section 3.4        Robert E. Baier, Vito A. DePalma, John M. Grace, Patrick M. Miller, Paul Rosenthal, Melvin I. Esrig\*, David J. Henkel\*, J. Steinback\*, Yudbir\*, R. D. Japp\*\*, S. J. Windisch\*\*, Raymond N. Yong\*\*, Gideon Dagan\*\*\*, Marshall P. Tullin\*\*\*

---

\*Department Geotechnical Engineering, Cornell University

\*\*Department of Civil Engineering and Applied Mechanics, McGill University

\*\*\*Hydronautics, Inc.

Section 3.5	Nelson M. Isada, Melvin H. Rudov, Robert C. Sugarman, Donald E. Sussman.
Section 3.6	John N. Andrews, Jr., George G. Sexton, Robert L. Smith, William C. Grenk <sup>****</sup> , Clifford J. Nuttall, Jr. <sup>****</sup>
Appendix A	Vanig V. Abrahamian, Manfred R. Belsdorf, Sol Kaufman, Robert L. Smith
Appendix B	Richard L. Pleuthner
Appendix C	John H. Quirk
Appendix D	Robert W. Coakley, H.T. McAdams, Walter F. Wood
Appendix E	Richard P. Leonard
Appendix F	Thomas R. Magorian
Appendix G	Peter E. Engler, Francis A. Giori, Phillip J. Joseph, Paul Rosenthal
Appendix H	Vito A. DePalma
Appendix I	Vito A. DePalma, R. D. Japp, Paul Rosenthal, Raymond N. Yong
Appendix J	Dominic F. Morris
Appendix K	Melvin H. Rudov, Robert C. Sugarman

---

\*\*\*\*WNRE Inc.

Appendix L      Nelson M. Isada, Robert C. Sugarman

The technical and administrative assistance and guidance provided by Messrs. Fredrick Dell'Amico, Arthur Stein, and Robert M. Stevens is also gratefully acknowledged.

TABLE OF CONTENTS

	<u>Page No.</u>
ABSTRACT.....	i
ACKNOWLEDGEMENT.....	ii
LIST OF FIGURES.....	vii
LIST OF TABLES.....	viii
GLOSSARY.....	ix

VOLUME I

1. SUMMARY.....	1
2. INTRODUCTION.....	5
3. ORMR - ACTIVITY SUMMARY.....	9
3.1 General Discussion.....	9
3.1.1 Vehicle System Dynamics Model.....	12
3.1.2 Environmental Research.....	14
3.1.3 Soil Mechanics Research.....	15
3.1.4 Driver.....	16
3.1.5 Systems.....	17
3.1.6 Off-Road Mobility Research Symposium.....	19
3.2 Vehicle Terrain Interaction.....	21
3.2.1 Vehicle-Terrain Model Development.....	21
3.2.1.1 Vehicle Dynamics Model.....	23
3.2.1.2 Mathematical Representation of the Running Gear-Ground Interface.....	31
3.2.1.3 Model Verification Tests.....	45
3.2.2 Evaluation of Existing Quantitative Methods of Predicting Vehicle Traction, Soil Resistance, and Trafficability.....	48
3.2.2.1 General Comments on Test Programs.....	49
3.2.2.2 Data Analysis.....	50
3.2.2.3 Test Programs.....	50
3.2.2.4 Results.....	52
3.2.3 Full Scale Mobility Test and Evaluation Practices.....	53
3.2.3.1 Literature Survey and Conclusions.....	55
3.2.3.2 Recommendations for Improvement of Test Practices.....	56
3.2.3.3 Proposed Areas for Research.....	58
3.3 Environmental Factors.....	61
3.3.1 Environmental Data Base for Off-Road Mobility.....	62
3.3.2 Environmental Basis of Off-Road Mobility Testing.....	67
3.3.3 Mobility Testing on Natural Soils.....	70
3.3.4 Data Output.....	80

Table of Contents (continued)

	<u>Page No.</u>
3.4	Soil Mechanics..... 91
3.4.1	Visioplasticity Method..... 91
3.4.2	Cornell University Activities..... 98
3.4.3	Hydronautics, Inc. Activity..... 100
3.4.4	Instrumentation Survey..... 102
3.4.5	Interparticle Force Study..... 103
3.4.6	Fabric Studies..... 104
3.4.7	Particle Surface Study..... 107
3.5	Human Factors..... 109
3.5.1	Driving Simulation - Visual..... 111
3.5.2	Driving Simulation - Motion..... 115
3.6	Systems Studies..... 123
3.6.1	Vehicle-Terrain Matching..... 125
3.6.2	Mobility Study of Four Vehicles..... 137
4.	RECOMMENDATIONS FOR FUTURE OFF-ROAD MOBILITY STUDIES..... 145
5.	REFERENCES..... 149

VOLUME II

Appendix A:	VEHICLE DYNAMICS MODEL FORMULATION.....	A-1
Appendix B:	TABULATED SUMMARIES OF VEHICLE TRAFFICABILITY DATA.....	B-1
Appendix C:	FULL SCALE TEST AND EVALUATION PRACTICE STUDY - DISCUSSIONS OF CONCLUSIONS AND RECOMMENDATIONS.....	C-1
Appendix D:	WATER BALANCE IN S.E. ASIA.....	D-1
Appendix E:	STATISTICAL DISTRIBUTION OF SOIL MOISTURE.....	E 1
Appendix F:	GEOMETRIC AND SOIL CHARACTERISTICS OF STREAMS.....	F-1
Appendix G:	INSTRUMENTATION FOR MEASUREMENTS WITHIN SOIL.....	G-1
Appendix H:	INTERPARTICLE FORCE CALCULATION FOR CLAY.....	H-1
Appendix I:	SOIL FABRIC STUDIES.....	I-1
Appendix J:	VISIBILITY STUDY--PLANS FOR FIELD TESTING.....	J-1
Appendix K:	AUXILIARY DISPLAYS FOR IMPROVING OFF-ROAD MOBILITY.....	K-1
Appendix L:	DESIGN FOR VEHICLE MOTION SIMULATION.....	L-1

## LIST OF FIGURES

### VOLUME I

<u>Figure No.</u>		<u>Page No.</u>
1	ORMR Plan of Action	11
2	Block Diagram of Vehicle Dynamics Model	24
3	Vehicle Response - Sudden Start and Symmetrical Bumps - Three Degree of Freedom Model	28
4	Vehicle Response to Bump Under Right Side Only Five Degree of Freedom Model	30
5	Suspension and Tire Peak Loads vs. Forward Velocity	32
6	Angular Peak Motion Amplitudes vs. Forward Velocity	33
7	PSD Curves For Various Ground Surfaces	35
8	Forces and Moment at Hub and Wheel-Ground Interface - Undulating, Rigid Terrain	38
9	Forces and Moments at Hub and Wheel-Ground Interface - Obstacle	39
10	Geometry of Wheel-Obstacle Interface	41
11	Forces and Moments at Hub and Wheel-Ground Interface - Soft, Smooth Soil	43
12	Pneumatic Wheel on Soft Soil - Three Stages of Radial Stress Distribution	44
13	Typical Cone Index, Adhesion and Angle of Internal Friction Curves	72
14	Surface Composition "RCI" Factor	81
15	Diagnostic Go/No-Go Map for M113 APC - Areal Features Only	84
16	Directional Computer Map "North" Distance to "No-Go"-WEASEL	85
17	OMNI-Directional Computer Map Minimum Distance to "No-Go"-WEASEL	86
18	Mobility Map Produced BY LDX Plotter for the 5 Ton GOER Vehicle	87
19	Energy Dissipation Rate Shown as a Function of Slip	95
20	Stress Distribution Calculated for Rigid Wheel Having Three-Percent Slip	97
21	Sketch of "First Step" Off-Road Driving Simulator	112
22	"Short-Throw" Motion Simulator - Design Sketch	117
23	"Long-Throw" Motion Simulator - Design Sketch	119
24	Off-Road Driving Simulator - Conceptual Sketch	121
25	Performance Boundary	128
26	Go/No-Go Map for M113	133
27	Go/No-Go Map for Hypothetical Vehicle	138

LIST OF TABLES

VOLUME I

<u>Table No.</u>		<u>Page No.</u>
1	Tentative Trafficability Groupings of Natural Soils	74
2	Basic Test Matrix	77
3	Comparison of Measured and Calculated Energy Dissipation Rates	95
4	Go/No-Go Test Sequence for Areal Terrain Features	129
5	Go/No-Go Test Sequence for Lineal Terrain Features	131
6	Summary of Most Critical Areal Terrain Configu- rations for Various Levels of Go	136
7	Comparison of Mobility Requirement Statements with Tests Performed	140

## GLOSSARY OF ACRONYMS AND CODE NAMES

AMC	Army Materiel Command
ARPA	Advanced Research Projects Agency
ATAC	Army Tank-Automotive Command
CAL	Cornell Aeronautical Laboratory, Inc.
CDC	Combat Development Command
CDOG	Combat Development Objective Guide
IDA	Institute for Defense Analyses
LLL	Land Locomotion Laboratory (of ATAC)
MC	Military Characteristics
MERS	Mobility Environment Research Study
MEXE	Military Engineering Experimental Establishment, Christchurch, England
MTP	Materiel Test Procedure
OPM	Ordnance Proof Manual
ORMR	Off-Road Mobility Research
PSD	Power Spectral Density
QMR	Qualitative Materiel Requirement
RCI	Rating Cone Index
SAE	Society of Automotive Engineers
TACOM	Tank-Automotive Command
TECOM	Test and Evaluation Command
TECP	Test and Evaluation Command Procedures
USCS	Unified Soil Classification System
VDM	Vehicle Dynamics Model
VMEA	Vehicle Mobility Exercise A
VSDM	Vehicle System Dynamics Model
WES	U.S. Army Engineer Waterways Experiment Station
WNRE, Inc.	Subcontractor to CAL (formerly Wilson, Nuttall, Raimond, Engineers, Inc.)

**BLANK PAGE**

## 1. SUMMARY

A review is made of the research conducted by CAL and several sub-contractors which was directed at overcoming major deficiencies in land vehicle locomotion theory and engineering practice. The purpose of the Off-Road Mobility Research Program has been to provide, in useful form, technical knowledge which is required to match off-road vehicles with military mobility requirements. The program was initiated in August 1966 as a long range study and organized to identify explicitly the man-vehicle-environment system interactions, define specific knowledge gaps regarding the principal functional elements of the system and then pursue research tasks to fill the knowledge gaps. A diagram of the research plan of approach is shown on Figure 1 in Section 3.1. In essence, the program is a "system of directed research" which follows logically from delineation of the off-road vehicle system.

The report concentrates on summarizing the studies performed over the period September 1967 to October 1968. An overview of the research is presented in Section 3.1. Subsequent sections treat each area of research in more depth. Where studies have not been reported or published elsewhere, they are included in full detail in appendices. A brief synopsis of the research reported herein is presented below.

1. The general structure and capabilities of a hybrid computer model for predicting vehicle dynamics performance of simulated wheeled vehicles over a broad spectrum of off-road situations are summarized in Section 3.2.1. Some sample outputs are presented. The manner of modeling the wheel-ground interactions is discussed and progress on field test work aimed at model validation is reported.

2. Results of a systematic evaluation of existing theory and practice in predicting vehicle trafficability off-the-road are summarized in Section

3.2.2. Using direct comparisons between previously published results for full scale tests and predictions calculated using quantitative theories, an attempt has been made to produce clearly defined limitations of the currently used theories as they relate to accuracy and range of applicability to different soils and specified ground contact elements.

3. A study which critically examined current practices in off-road vehicle testing and evaluation is summarized in Section 3.2.3. Conclusions drawn in the study are discussed, recommendations for improvement of test practices are presented and proposed areas of research are outlined.

4. Progress on assessing the available base of environmental data for purposes of off-road mobility is summarized in Section 3.3.1. Principal sources and formats of environmental data collections are identified and approaches to utilizing the existing data base to indirectly arrive at quantitative mobility information are presented.

5. A systematic structure of negotiability tests was synthesized for defining the environmental performance envelopes of off-road vehicles. These tests are based on the premise that the world environment, for mobility purposes, can be resolved into a finite number of elementary environmental classes. Section 3.3.2 and 3.3.3 summarize this work.

6. Computer techniques developed on the ORMR program for constructing maps of vehicle performance in specified environments are presented in Section 3.3.4 and the relation of such maps to statistical aggregation is discussed.

7. The adaptation of the visioelasticity method of analysis to the investigation of soft-soil mobility problems is discussed in Section 3.4.1. The method is applied in relating experimentally obtained kinematic variables (velocity, strain rates and strain) under a two dimensional powered slipping

wheel to the load variables (forces and stresses) which were obtained analytically. Supporting research associated with the choice of soils and soil preparation methods for laboratory studies of soil-vehicle interaction are also summarized in Section 3.4.2.

8. An analytical study is summarized in Section 3.4.3 that investigated, in a basic way, the problem of soil flow beneath a wheel being driven over a rigid plastic solid.

9. Initial attempts at developing quantitative methods for describing clay fabric are summarized in Section 3.4.6. This investigation, which is in a very preliminary state, has as goals, the describing of soil state by its internal geometry and the determination of internal energy dissipation from changes in internal geometry.

10. Progress on the design and development of an off-road driving simulator is summarized in Section 3.5. With this simulator the Vehicle Dynamics Model, given terrain and driver inputs, would feed back vehicle dynamic response to a driver to provide him with motion and visual cues. An outline is included in Appendix J of a proposed field test program for obtaining quantitative data which will provide a basis against which to check the simulator performance.

11. A viable method has been developed and demonstrated for formulating testable off-road performance specifications for vehicles adapted to specific terrain, through the analysis, by computer, of relatively high resolution quantitative terrain data. This activity is summarized in Section 3.6.1.

12. A case study of the development and operational history of four off-road vehicles is summarized in Section 3.6.2. Conclusions and recommendations relating to vehicle specification, program management, testing and evaluation practices, training and operations are included.

Some recommendations for future off-road mobility studies are presented in Section 4 and include the following:

- Extend the Vehicle Dynamics model to broader application and correlate VDM outputs with field tests results to assess model validity.
- Develop working theories for the several fundamental traction modes to permit determining limiting values of the performance of "unconventional" ground contact vehicles.
- Extend and apply the viscoplasticity method to the analysis of problems involving interactions of soft soil with realistic wheels and soil measuring instruments.
- Continue development of computer techniques for mobility map-producing applications.
- Pursue the development of a concept of structuring environmental description in vehicular terms to permit classifying global environment in terms of vehicle mobility.
- Continue development of a driving simulator which when completed would be applied to gathering information related to basic driver-limited vehicle performance functions.
- Pursue a systems research investigation aimed at relating how and why technological advances in off-road mobility may be effectively used by selectors and decision-makers to yield operational payoffs.

## 2. INTRODUCTION

Many years of prototype construction, experimentation and field use have produced combat vehicles which perform reasonably well in some environments, and have led to the development of a substantial body of engineering design practices. Parallel activities along more theoretical lines have produced a number of moderately successful soil trafficability theories. Nevertheless, the selectors, designers and evaluators have too often found this background inadequate for extensions beyond the boundaries of the familiar and the well-tested, i.e., inadequate: for predicting how vehicles will perform in remote environments, for assessing the value of new vehicle concepts over given terrain, and for providing a quantitative basis to help guide vehicle design and development along directions which enhance mobility within the overall military context.

The basic sources of these inadequacies may be two-fold. One is insufficient organization of what is known concerning off-road mobility in forms most applicable to questions raised by the planners, selectors, users and designers. The other is the failure, thus far, to delve deeply enough into the complex physical and human processes which occur within the vehicle and within the earth below it and which interact at the vehicle-terrain interface.

In August of 1966 Cornell Aeronautical Laboratory, Inc. under contract to the Advanced Research Projects Agency initiated a six-month study to review the state of knowledge in off-road mobility and define a long-range program of research. The results of that study were published in March 1967.<sup>1</sup>

In February of 1967 the contract was extended to include a second phase effort, and CAL then initiated research on a long-range program. The objective of this Off-Road Mobility Research program has been to provide, in useful form, technical knowledge which is required to match off-road vehicles with military mobility requirements.

---

<sup>1</sup>See Section 5 for numbered references.

Thus far, the CAL ORMR program has been addressed at identifying and finding ways of overcoming major deficiencies in land vehicle locomotion theory and engineering practice, which have prevented generation of good quantitative predictions. These are:

Inadequate knowledge of the dynamic reactions between the land vehicle and its operating medium; how energy is dissipated in the soil, and the distribution of forces at the interface, as functions of applied loadings. There is no sound theoretical basis for scaling laws, or for instrumented measurement of these phenomena.

Inadequate classification and mapping of the terrain in potential military operating areas, in categories significant to vehicle-terrain interaction, to enable satisfactory prediction of the performance of military vehicles in these areas.

Inadequate knowledge of the human performance in the vehicle-man-environment system as a sensor, decision maker and controller, to enable description and parametric exploration of the effects of human limitations and control doctrine on the mobility process.

Inadequate development of standard structural vehicle design criteria and procedures to produce efficient structures with improved reliability.

It will be noted that these regions of deficiency intersect; that is, answers in one depend upon answers in the others. Thus, predictions of land vehicle cross-country performance depend upon treatment of the vehicle-man-environment interactions. The CAL ORMR program has been organized to identify explicitly the system structure, and to define specific knowledge gaps in the principal functional elements of the system. Then having derived specific

requirements for fundamental knowledge, ORMR has contributed toward achieving solutions via several routes -- by re-examining the results of past work on the same and closely related problems; by subcontracting for new work by recognized experts; by recommending to the DOD programs for new investigation, material and procedures development; and by conducting research within the CAL ORMR organization.

More than 20 technical reports and papers documenting significant technical findings and accomplishments have been published by CAL and sub-contractors during the life of the contract. This report summarizes the research (some described more fully in these reports, some previously unreported) which has been conducted on the ORMR program during the past year.

**BLANK PAGE**

### 3. ORMR - ACTIVITY SUMMARY

#### 3.1 GENERAL DISCUSSION

In conducting the off-road mobility research program we have been always mindful that its ultimate application will be to provide better bases for decisions: - decisions by the force planners as to what vehicle mixes will provide the mobility capabilities assumed in their contingency plans at acceptable costs; decisions by the tacticians as to how to plan their missions and tactics which depend on ground maneuverability; and decisions by the designers who seek the best compromises among configurations, payload distributions, tractive and propulsive modes, speeds, ranges and fuel economies, reliability, etc. That is, the purpose of the research is to provide that technical knowledge which is required to examine the trade-offs available among military requirements and vehicle capabilities and costs.

The prime technical requirement is that of producing means for predicting the military mobility capabilities of land vehicles operating in specified environments within meaningful and known confidence intervals. This requirement cannot be satisfied entirely by experimentation, unless the nation is willing and able to produce and test combinations of every interesting candidate vehicle in every environment. Thus, an adequate body of theory, of which the limits of generalization are delineated by carefully selected and conducted experiments, must be found or developed and applied.

How well is this requirement satisfied today? Not at all well according to the records of comparisons between measured performance values of vehicles driven in the field and predicted values derived from theory and laboratory tests. (See sections 3.2.2 and 3.2.3).

The assessment of whether we have adequate means of predicting off-road vehicle performance remains qualitative, for two principal reasons. One is associated with the question of the sensitivity of decisions for vehicle

selection, procurement and R&D to prediction errors. The other, in the technical context, is that the comparisons aggregate many contributing uncertainties to produce an overall uncertainty. Some of the uncertainties are associated with the validity of the theory and of the predictive methodology; others are associated with the adequacy of the experiment control and measurement procedures. In most cases examined, (see section 3.2.2) it was impossible to sort out the uncertainties due to inadequate experiment design, measurement and control from those due to inadequate prediction methodology. Clearly, it is necessary to find the boundaries between what is known and what is unknown (and even unknowable) concerning the ability to predict the offroad performance of ground vehicles. To reach this goal two major elements are required - carefully designed, controlled and measured experiments and a sufficiently complete model of the mechanics and processes involved in driving a vehicle off-road so that the experimenter will know what to design, how to measure and control, and how to analyze the resultant data.

CAL's initial effort on ORMR was to rough out such a model of the off-road vehicle mobility system, inasmuch as it provided useful guidance even during the survey phase of the program concerning the categories of past and on-going work to be examined in some depth. The simplest form of our model assumed off-road vehicle mobility to be a function of three major elements, the vehicle, the driver, and the environment and identified explicitly what seemed to be the significant interactions among these variables and the many detailed vehicle, driver environment characteristics on which the values of these variables depended. With this in hand, our surveys examined what was known or unknown concerning the characteristics and their interactions, and we designed a program <sup>1</sup> to fill the knowledge gaps and to provide the links between descriptions of basic mechanics and processes and the information needed by the users to make their decisions. Figure 1 is a flow diagram of our program. Our work has followed this plan. In essence, it is a "system of directed research" which follows logically from delineation of the off-road vehicle system.



Keeping in mind that we are seeking a predictive methodology, that we want to identify those system characteristics to which "real-world" off-road mobility is sensitive and those to which it is not, that we are trying to bound the individual performance uncertainties which contribute to overall system performance uncertainty, and that we need to specify the measurements which are significant in understanding and explaining the results of experiments, we divided our work into five main categories, which follow from our basic model: - vehicle, environmental, soil, driver and system studies. The character of the work in each category is as follows.

### 3.1.1 Vehicle System Dynamics Model

The vehicle is the physical intermediary between the driver and the environment, the variable which can be controlled and configured, and the product to the user to operate and to evaluate.

We have undertaken the detailed modelling of the dynamic driver-vehicle-environment system for two reasons. The first is to move from abstract, functional models to explicit mathematical descriptions of the physical processes and interactions. In such model development, knowledge gaps or uncertainties are clearly revealed. The second is to provide a tool for exploring rapidly the dynamic interactions between a total vehicle and its operating medium, where the loads applied to and the forces developed from the terrain/soil combine to form a complex dynamical system. By use of the model, effects of alternative assumptions, configurations and controls can be examined. Provisions are made to insert the driver in an analog computer mechanization of the model so that, with the addition of appropriate displays, the uncertainties of driver performance can be systematically explored. Provisions are made to determine displacements, loads and accelerations throughout the mechanical system with the view of providing the means for rational structural design.

In view of previous remarks concerning the likely presence of irreducible uncertainties in the overall off-road mobility process, viz., heterogeneity of the physical environment (many aspects of which are not practically measurable) and the driver (his individuality and psychophysiological state), it may be asked what purpose is served by a detailed, very precise theory and model of the physical interaction between vehicle and ground environment? To restate one answer, which is already implicit in the preceding paragraph, it may aid the vehicle designer in the rational selection of superior vehicle concepts and details of running gear configurations for specified environmental conditions. A suggestive analogy may be drawn with the electronics designer who optimizes a signal processing circuit based on a nominal input despite the fact that in actual operation the signal will be severely corrupted by noise. Thus, in contrast to the tactician and high-level planner for whom the uncertainties are dominant, the designer without a precise model may not be able to realize fully the intrinsic physical potential of ground-based mobility.

We have in operation a five-degree-of-freedom (roll, pitch, heave, surge and sideslip) model of the M715 wheeled vehicle, to which a sixth (yaw) degree of freedom can readily be added. A discussion of its characteristics is given in section 3.2.1. The present model is readily adaptable to many wheeled, including articulated, vehicles. Vehicle-terrain interactions can be represented by any of the current, or modified theories. The M715 vehicle was selected as the first vehicle to be modeled since we have at the Laboratory a M715 vehicle which has been instrumented to measure the principal forces and displacements (and derivatives) corresponding to those that are read out from our analog model, and therefore, in carefully designed experiments, are being used to determine the correspondence between theory and measurement. (See section 3.2.1.4).

The model is extendable to a tracked configuration, and with such extension could be employed to explore a variety of wheeled and tracked combinations.

Finally, as was indicated previously and will be discussed again in the Driver section, 3.1.4, we have been examining how the model can be linked with a motion platform and visual display to produce a driving simulator whereby the interactions of the total system can be systematically explored.

### 3.1.2 Environmental Research

Our environmental research has revolved around terrain analysis and descriptions where we have been concentrating on two issues. The first is that of finding ways of relating vehicle characteristics to determinable terrain/soil/geographic characteristics such that "vehicle mobility maps" can be produced for reasonably large geographic areas. In this, we are addressing two problems. (a) We are seeking feasible and convenient ways of presenting to the military user what is required in the way of vehicle capabilities to achieve various amounts of cross-country mobility, and in this way providing a tool for the military trade-off analyses which will be discussed further in section 3.3.3. (b) We are describing those terrain characteristics which offer varying impedances to achievement of cross-country mobility in terms of "testable performance specifications" to be used by the specifiers and evaluators. Second, we are addressing the questions of how to formulate a set of unit environments sufficient to span the world environment, and how to delimit this set to the minimum set which is both sufficient and necessary to state appropriate combinations of descriptor values to be used in testing and predicting performance envelopes of vehicles in commonly occurring terrain complexes. Associated with this, we are exploring predictive techniques for relating easily observable environmental facts to those difficult to observe, with one objective being that of developing methods for extracting vehicle-scale environmental data from data larger than vehicle scale. If the planners and selectors are to consider appropriately the trade-offs between environmental challenges and vehicle

capabilities on a global or regional scale, it is necessary to develop such techniques for describing global and regional environments so that the job is manageable.

The results of our work on environmental research are presented and discussed in sections 3.3 and 3.6.1.

### 3.1.3 Soil Mechanics Research

Prediction of tractive and resistive forces developed under a moving wheel, track, screw or foot depends on knowledge of the dynamic flow field in the soil, the partitioning of the energies dissipated in the soil and at the soil-vehicle interface, and the distribution of the forces at the interface. Although existing prediction equations and soil measurement devices stem from theories concerning soil behavior under load, the measurements made to assess the validity of the equations have invariably been made external to the soil. Thus, the underlying theory has not been tested, and may be a source of prediction uncertainties.

During the past year we have subcontracted with Prof. Yong at McGill University for the measurement of soil displacement under a few selected wheel loadings, and for stress-strain measurements of the samples of the soil used. Techniques developed by Prof. Yong<sup>2</sup> have enabled soil displacement measurements in a two-dimensional soil bed. With the experimental results obtained from Prof. Yong we have been able to calculate the velocity field and the strain rates and strain in the soil and, from an analytical solution of the equations of motion employing the constitutive (stress-strain) relations, we have obtained the stress distribution beneath the wheel. Typical results are presented and discussed in section 3.4. Also discussed in section 3.4 are more basic studies and analyses of wheel-soil interactions, soft soil properties and soil fabric which have been pursued over the past year by CAL and via subcontracts with Professors Henkel and Esrig at Cornell University and Drs. Dagan and Tullin at Hydronautics Inc.

In addition to the soil research discussed in section 3.4 CAL also monitored a classified study subcontracted to Dow Chemical Co., Midland, Michigan dealing with soil stabilization. This research which was conducted under the ORMR program in support of the Commando Lava project is reported in Reference 3.

#### 3.1.4 Driver

The driver, as a sensor, decision maker and controller, selects the terrain which his vehicle will be called upon to traverse, selects the desired speed of traversal, diagnoses the causes of incipient or actual motion impedances and applies corrective control. His sensory cues are visual, aural and proprioceptive, resulting from motion, and he controls the rate and direction of motion. Regardless of the capabilities of the vehicle, the driver will select what appear to him to be tolerable limits to motion, based both on the current situation and what he anticipates the future situation will be. He can and does override the mechanical characteristics of the vehicle and its interactions with the terrain. Thus, military performance capabilities of importance such as average speed or dynamic loads and displacements applied to the crew, passengers and cargo may be much more a function of driver than of vehicle capabilities. Thus, as noted earlier, uncertainties concerning driver performance may dominate all other uncertainties in off-road mobility.

We have devoted effort to examining ways of bounding and reducing these uncertainties. It is apparent that the research must be experimental. It would be hoped that some experiments might be designed which were "vehicle independent" that is, where human transfer functions between motion perception and control would be found which were independent of the particular type of vehicle.

Experiments may be made in the field, using real vehicles, or in the laboratory, using simulators. Field experiments have the advantages of realism, but are difficult to control and reproduce, and are vehicle dependent. Simulators allow fine control and reproduction, and parametric variations of inputs. A few field experiments can be made inexpensively, but the costs mount as one enlarges the range of variables to be investigated. The initial cost of simulation is high, but once paid, a wide range of variables may be explored relatively inexpensively. Obviously, when one contemplates "vehicle dependent" experiments on conceptual vehicles, simulation offers the only tool.

We believe that a programmed development of simulation capability, with the results of the early steps referenced against field experiments, is the best way to proceed. Therefore, we have been starting with a relatively simple simulator with which to explore the relationships between visual cues and speed control. We have been preparing, with the use of the vehicle dynamics model which will provide the input to a suitable motion simulator, to go next to exploring the effects of both visual and motion cues on speed control.

In section 3.5 the progress made in defining and developing a ground vehicle simulator is reported. Also human factors experiments dealing with auxiliary driving aids and the effects of visibility on driver performances are discussed.

### 3.1.5 Systems

It is observed that investigation of each of the major elements of the off-road mobility systems discussed in the paragraphs above could not by necessity be divorced from the remaining elements.

The primary objective of systems study is to relate output (achievement of mobility or satisfaction of mission) to input (environmental and mission demands) in terms of the parameters and relationships which describe the elements of the system. In this sense it involves integration of the activities being separately pursued with respect to the primary elements. As a first step we had gone through the exercise of detailing the organization of physical mobility aspects of the system and also catalogued distinguishable concerned groups within the military community and their specific informational needs relative to ORM.<sup>1</sup> We have since familiarized ourselves with current military off-road mobility requirements and the procedures by which they are established.<sup>4</sup>

More definitively, we have formulated desirable directions for CAL activity within a "system of directed research", as outlined in Figure 1 and have been laying the groundwork for compatibility and integration of the Vehicle Dynamics Model and Driving Simulator within an overall Vehicle System Dynamics Model (VSDM). In addition to serving as a predictive tool for estimating the mobility performance of given vehicles (existing and proposed) in various unit environments, the VSDM could be expected to have additional application in the areas of human engineering and training.

The real military needs of vehicle evaluation, selection, and tactical employment require answers in the context of complex environmental configurations associated with specific regions of the world. We have anticipated that the methods of environmental description previously discussed, together with the mobility performance results for unit environments as derived from the VSDM could be combined in an Aggregated Performance Model (formerly referred to as Phenomenological Model<sup>4</sup>) to yield appropriate statistical inferences regarding overall regional performance.

Similarly, the application of VSDM results to regional unit environment maps might be an attractive method for developing vehicle-specific cross-country movement maps for use in detailed operational planning.

Two specific systems studies were conducted during the past year. One was a probing methodological study pursued jointly by CAL and WNRE Inc. Its object was to develop a method for formulating testable off-road performance specifications for vehicles adapted to specific terrain, through the analysis of quantitative terrain data. A secondary objective was to demonstrate this procedure by generating a set of testable specifications for sample vehicles in an exemplary Southeast Asia terrain. The second system study was a case study made of the development and operational history of four U.S. Army off-road vehicles. The object was to gain insight into the relationships which historically have existed between mobility requirements and vehicle research and development testing. These two studies are reported in section 3.6.

#### 3.1.6 Off-Road Mobility Research Symposium

Lastly on ad hoc activity conducted by CAL under ORMR in conjunction with the International Society for Terrain Vehicle Systems was an Off-Road Mobility Research Symposium with the theme Mobility Testing. This forum held in Washington, D.C. on June 26-27 1968 was attended by more than two hundred researchers, designers, testers, and users of off-road vehicles from more than seventy military, industrial and educational agencies from the United States and abroad.

The program consisted of 16 technical papers and 3 panel sessions. Three of the papers<sup>5,6,7</sup> were contributed by the ORMR program and one of the panel moderators was Mr. A. Stein, CAL's representative on the ORMR

Steering Committee. Mr. Ira Ross, President of CAL was Master of Ceremonies of the Symposium banquet at which Lt. General W. B. Bunker, Deputy Commanding General, U.S. Army Materiel Command was the speaker. Major responsibilities for the general arrangements, publicity and publication of the symposium proceedings were borne by members of the ORMR staff.

## 3.2 VEHICLE TERRAIN INTERACTION

Progress during the past year has been made in three problem areas under the vehicle-terrain interaction task. These are: (1) vehicle-terrain model development, in which emphasis has been placed on the vehicle dynamics model, terrain modeling, and detailed mathematical modeling of running gear-soil mechanics; (2) evaluation of existing quantitative methods of predicting vehicle traction, soil resistance and trafficability, and (3) evaluation of current full-scale test and evaluation practices.

### 3.2.1 Vehicle-Terrain Model Development

A comprehensive survey of existing vehicle-terrain computer models was completed by CAL last year<sup>4</sup>. The survey disclosed a number of models available for evaluating various aspects of vehicle design. However, many of these are restricted to specialized purposes and none to our knowledge has the broad predictive capabilities that we believe are required. Our position is that the scope and precision of an adequate model should permit prediction of real world vehicle dynamics and performance as well as providing vehicle component loading information for use in structural analysis.

The decision was therefore made to develop an improved capability for off-road mobility performance prediction through mathematical modeling of the vehicle-terrain system. An added benefit to be derived from the model development is the pinpointing of information gaps in off-road mobility technology which require added research.

It is CAL's position that an effective vehicle-terrain model should include the following:

- Vehicle operation in complex terrain situations demanding capability for handling large translational and rotational motions, system nonlinearities and detailed representation of running gear-terrain interactions.
- Representations of running-gear and suspension systems and drive trains that may be readily varied. A modular approach to modeling can probably best provide the desired versatility.
- Provision for rigid hull designs and extensions which may include flexural modes.
- Explicit representation of critical loading points internal to the vehicle to provide realistic structural criteria for design and reliability purposes.
- Model mechanization using a hybrid computer to permit rapid and low-cost analysis and adaptability to future incorporation of the driver in the vehicle-terrain interaction loop.

In the subsections to follow, and also in Reference 8 the general structure and capabilities of the present Vehicle Dynamics Model (VDM) are summarized and some sample outputs are presented. Next is a discussion of how terrain and wheel-ground interactions are modeled. Finally, progress is reported on field test work directed toward model validation.

### 3.2.1.1 Vehicle Dynamics Model

A hybrid model has been chosen to combine the advantages of rapid analog computation of vehicle dynamics with versatile digital representation of terrain. Because the bulk of the equation solving is done on all-electronic analog computers, it is possible to run problems as fast as 10 times real time, and in some cases 100 times. A digital model using the same equations as the analog model has been programmed for backup and check-out, but it falls far short of running at real time. An advantage of the high speed of the hybrid model is that it permits running in the repetitive operation ("rep-op") mode. In this mode the simulation solves the problem many times over in a short time period, allowing the operator to vary vehicle and terrain parameters and observe instantaneously on an oscilloscope the effects on system response. Thus parameter variation and sensitivity studies can be performed with great ease and without accumulating extensive strip charts. The basic approach in constructing the VDM has been to work within a general framework with interchangeable modules to provide versatility. The model is structured to accommodate not only conventional wheeled and tracked vehicles but also advanced designs incorporating articulation and other innovations.

The modular construction is shown in Figure 2. The five major modules are:

- (1) Hull
- (2) Suspension
- (3) Axle-Wheel Assembly
- (4) Drive System
- (5) Terrain Interface

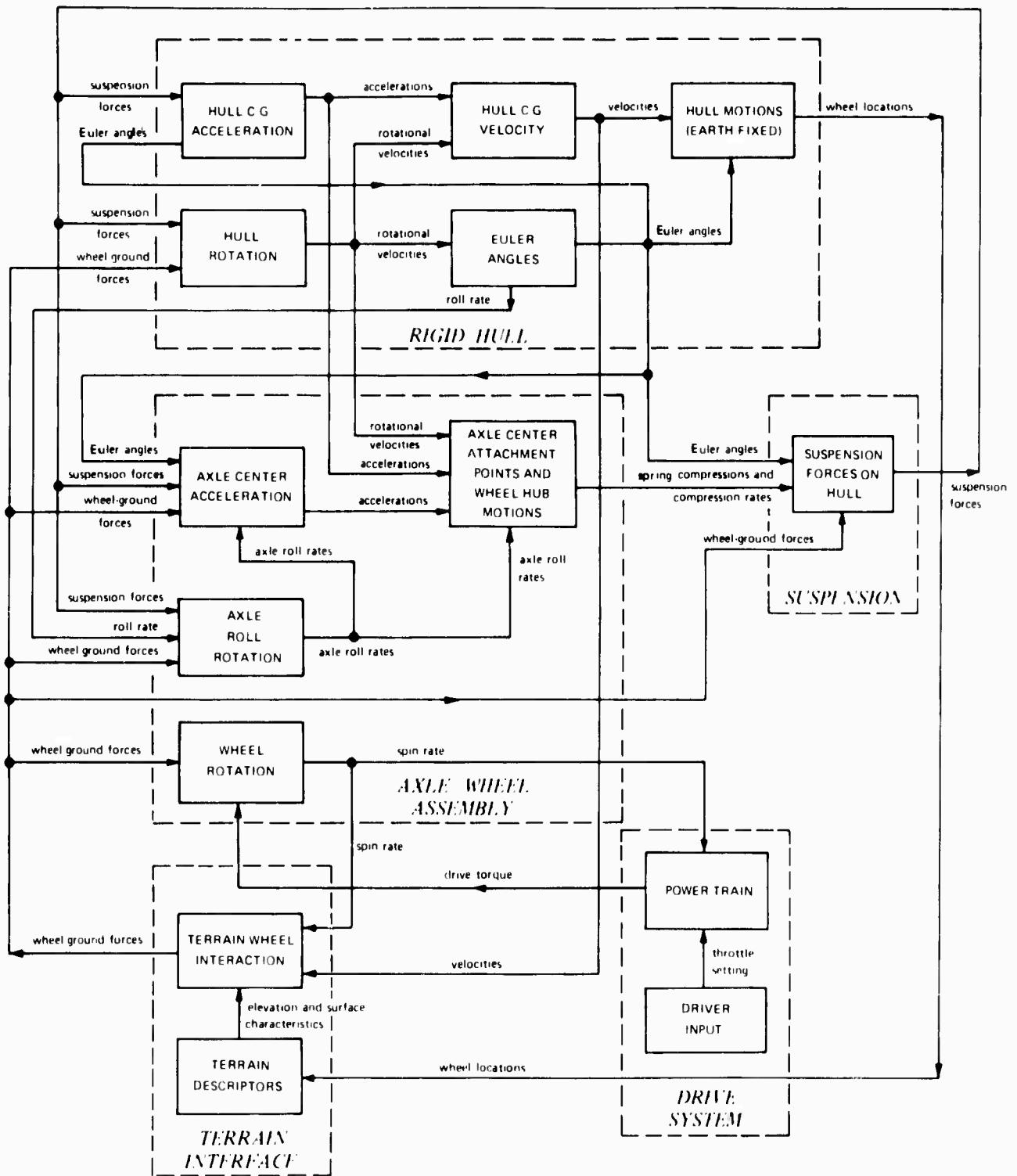

Figure 2 BLOCK DIAGRAM OF VEHICLE DYNAMICS MODEL

A further breakdown into some of the more important submodules is also shown. Additional detail, including a listing of VDM equations may be found in Appendix A.

The initial modeling activity has been concerned with wheeled and tracked vehicles for two major reasons: (1) existing and near future military inventories are and will be comprised, for the most part, of vehicles possessing these conventional running gear, and (2) modeling of a wheeled vehicle with a small number of axles is the least complex for exploration of detailed modeling problems and for resolving the uncertainties which may be found to exist when testing the hypothesis that the mathematical model represents its physical counterpart with acceptable fidelity.

The first vehicle type selected for implementation of the VDM was a wheeled vehicle with sprung solid axles. The vehicle equations of motion were mechanized on CAL's analog computers (two COMCOR Inc. Ci-5000 consoles). Ancillary expressions, in particular most of those describing terrain, and output data processing, are handled digitally on a Honeywell DDP116 with eventual tie-in to the IBM 360/65 contemplated to accommodate model growth.

Specifically a 4-wheeled vehicle (with nominal parameters based on the M715, 4x4, 1-1/4 ton utility truck) has been modeled using 5 degrees of freedom for the hull: longitudinal translation (surge), vertical translation (bounce) and lateral translation of the hull center of gravity; and pitch and roll about perpendicular axes through the hull center of gravity. Each of the two axle assemblies has three degrees of freedom relative to the hull: vertical displacement of an axle center, roll about an axle center and wheel rotation. The total number of degrees of freedom then may be considered to be (hull modes) + (axle/hull modes) x (no. of axles); hence we presently have implemented an 11 degree of freedom system.

We now proceed to discuss briefly the five major modules as they are presently represented, noting again that more detailed descriptions are contained in Appendix A.

The vehicle-hull is presently mechanized as a rigid mass with lateral (i.e. right-to-left) symmetry. Hull motions are computed in body-fixed axes, then related to an earth-fixed reference frame through a commonly used Euler angle sequence.

Associated with each wheel is one of four similar suspensions, each consisting of a multi-leaf spring, a shock absorber and a hard rubber bump stop which limits suspension travel. Refer to Figures A-5 and A-6 of Appendix A for nonlinear characteristics of the suspensions as currently represented in the simulation.

Representation of the solid axles and wheels follows a model used by McHenry<sup>9</sup> which he and others have validated. It is based on transmission of vertical forces through the suspension to the hull in the usual way. Forces parallel to the vehicle longitudinal and lateral axes and pitch and yaw moments, however, are transmitted to the hull through hypothetical weightless vertical columns connected to each axle center through a pivoted joint which allows relative roll between axle and hull. The contact of the columns with the hull allows relative vertical motion (assumed frictionless), so that no vertical forces can be transmitted by the columns (see Figure A-2).

Representation of the drive system includes an engine connected to a four-speed transmission through a two-speed transfer case. Because of the modular construction of the model, the power plant and/or power train can easily be modified or replaced as desired.

The current representation of vehicle running gear and ground interaction is one for pneumatic tires on undulating undeformable surfaces of varying slipperiness. Mathematical models have also been formulated for (1) a tire traversing sharp obstacles, and (2) a tire traversing soft soil. These models discussed in Section 3.2.1.2 are available for replacing the present terrain interface module as appropriate.

At present, the CAL vehicle dynamics model is being checked out preparatory to its use as a research tool. During the simulation development, a number of runs and outputs were recorded and, while these outputs do not represent complete solutions of particular problems, they illustrate the problem-solving capabilities which have so far been achieved.

Two sets of runs are presented here, one from an interim three degree of freedom traction-slip model, the other from the five degree of freedom model. The nominal parameter values used in both runs are those for the M715 truck.

Illustrative results from the traction-slip model are shown in Figure 3. This run, over a series of bumps was made from a standing start, with full throttle applied at time  $t=0$ . The resulting engine torque variations are shown on channel 4; the accompanying initial changes in wheel angular velocity\* and slip, which peaks at almost 90%, are shown on channels 2 and 3, with the resulting buildup in forward velocity component on channel 1.

About one second after the run starts, the front wheels encounter the first of a set of bumps. These are triangular in shape, with 4-in peaks

---

\* All four wheels were constrained to the same instantaneous angular velocity.

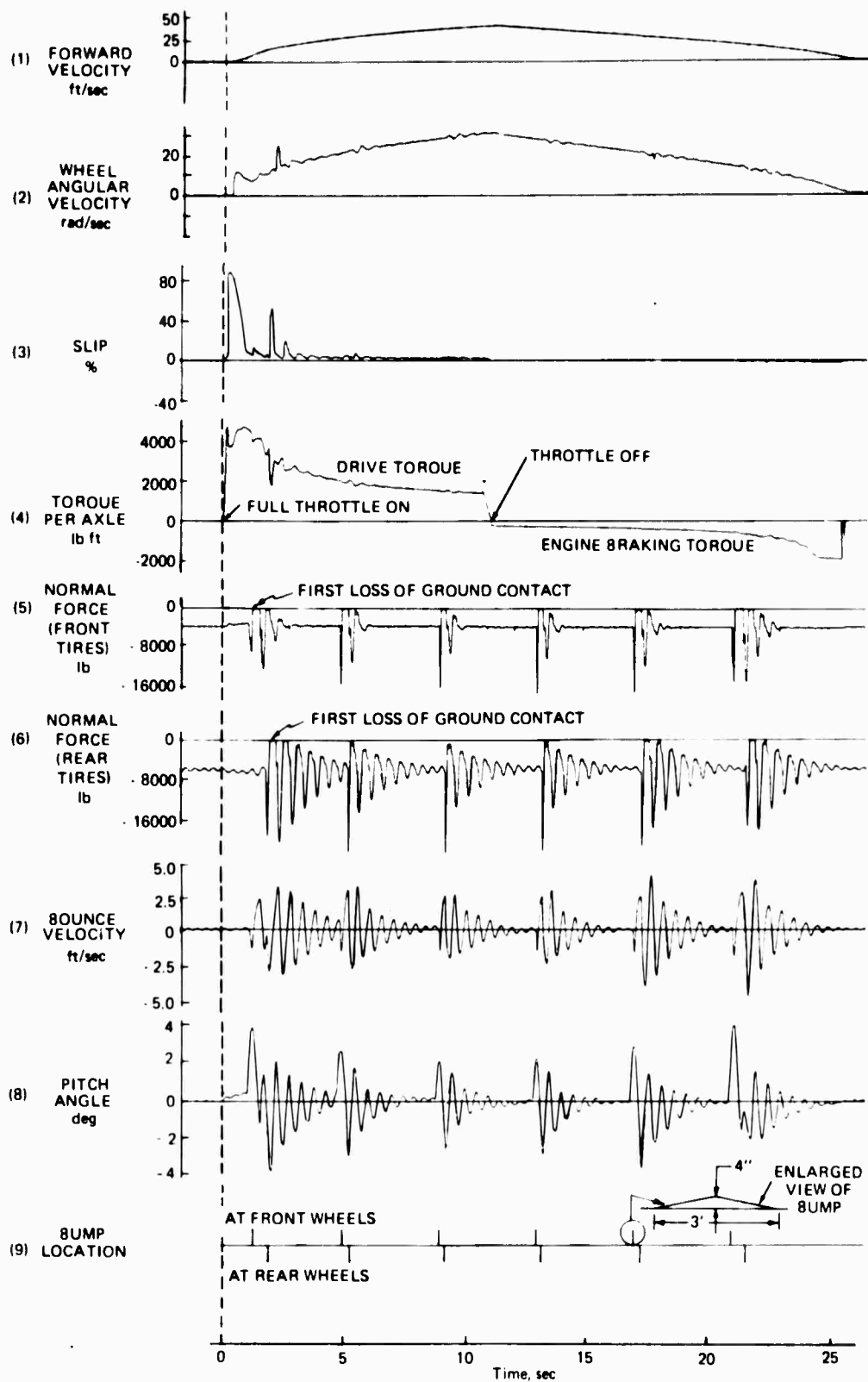

Figure 3 VEHICLE RESPONSE - SUDDEN START AND SYMMETRICAL BUMPS - THREE DEGREE OF FREEDOM MODEL

and 3 ft bases. They were struck simultaneously by the left and right wheels, with the delay at the rear wheels properly accounted for. The six bumps were encountered by the front wheel at equally spaced intervals in time. Rather severe transients are noted to take place at each bump. In fact, frequent loss of ground contact is indicated on channels 5 and 6 when the tire-ground forces flatten out at zero.

Bounce and pitch transients (channels 7 and 8) are also rather severe, even though the triangular bump presents a comparatively mild off-road obstacle. Reading the steepest peak-to-peak slope from channel 7 shows that bounce accelerations approach 1 g. Vehicle response of this nature emphasizes the need for complete, nonlinear representation of the suspension components (leaf springs, bump stops and shock absorbers) in modeling off-road behavior, as opposed to on-road modeling in which a much simpler linearized representation has often proved sufficient. When the throttle is cut after about 10 seconds (channel 4), the vehicle is seen to start decelerating (channel 1), mainly because of engine braking torque (channel 4), which increases as down shifting of the gears takes place with the decreasing velocity. The run ends simply with the vehicle coasting to a stop.

A sample run from the five degree of freedom model is shown in Figure 4. This run, made with constant vehicle speed of 20 ft/sec, demonstrates combined roll and pitch transients. The transients are produced by a single triangular bump the same as described above, but in this case encountered only by the right wheels. Just before the bump is hit by the front right wheel, the axles and hull are all in a horizontal position. Upon impact, the right front wheel is raised so that a negative\* front axle roll angle (measured relative to the hull) builds up as seen on channel 3 (see Reference 8 for further discussion).

---

\* All roll angles are defined positive clockwise as the vehicle is viewed from the rear.

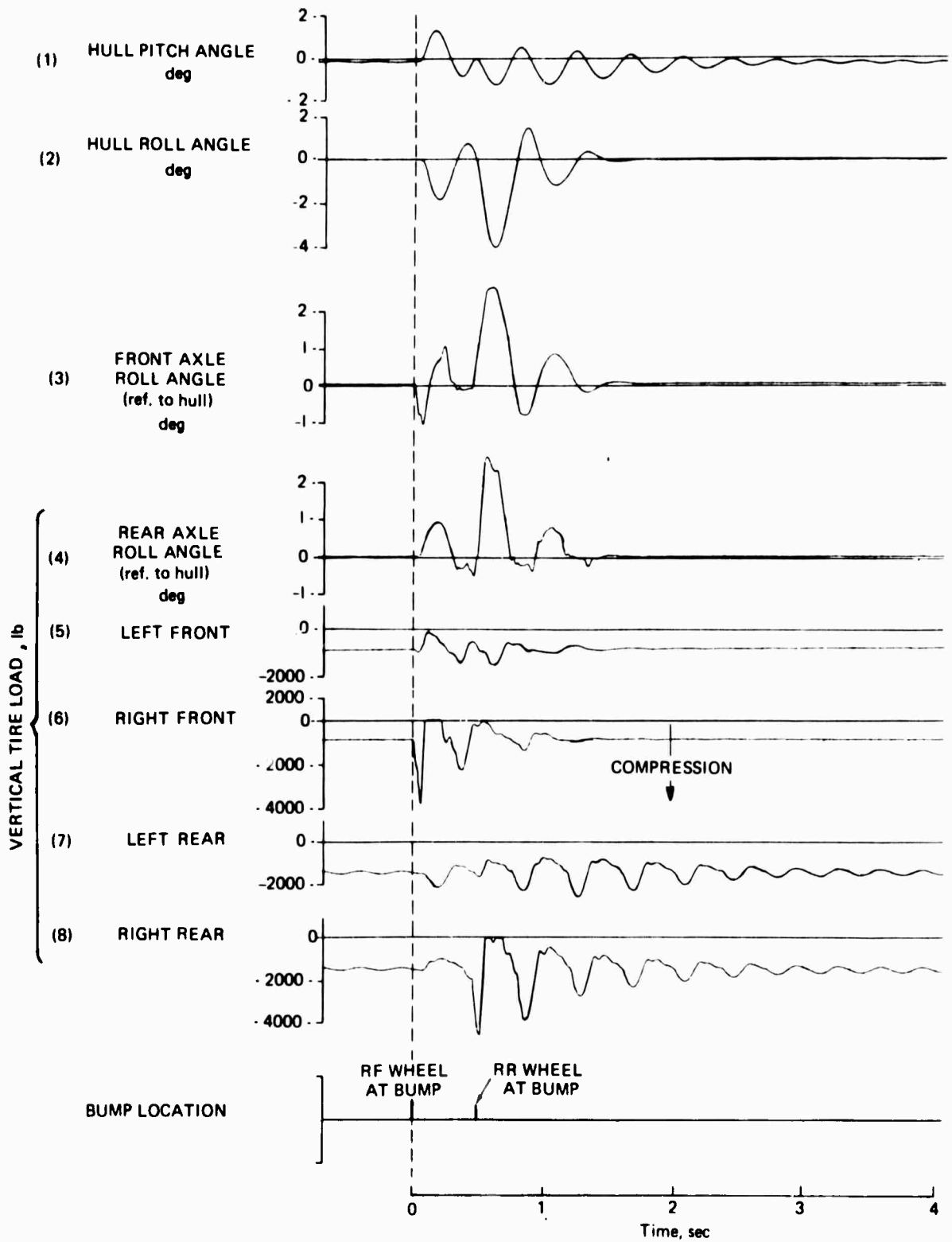

Figure 4 VEHICLE RESPONSE TO BUMP UNDER RIGHT SIDE ONLY  
FIVE DEGREE OF FREEDOM MODEL

Runs like the one just described were made at several velocities, and the peak values of some of the key variables have been plotted. They are shown here as illustrative of the kind of parametric analyses that can be performed using the present simulation. Figure 5 shows the peak forces on the rear tires and suspensions as a function of vehicle speed. Figure 6 presents the hull pitch and roll angle peaks and also the peak values of the roll angle of the rear axle versus vehicle speed.

### 3.2.1.2 Mathematical Representation of the Running Gear-Ground Interface

The important role of the running gear-ground interface in vehicle performance prediction was recognized early in the development of the VDM. In order to take advantage of some of the experience which exists in running gear-ground modeling, a subcontract was let to General Motors, Defense Research Laboratories for the mathematical formulation of models for computer implementation at CAL. Our initial model implementation efforts have been for wheeled vehicles, therefore the emphasis has been on wheel-ground interface modeling. The models, as formulated, are amenable to programming for digital or for analog computation and hence furnish an option for the current hybrid modeling scheme. Summarized here are the wheel-ground interface models. Further treatment of this topic as well as track-ground interface modeling are the subjects of a planned ORMR technical memorandum report.

The mathematically modeled wheel - Realistic representation of the soil-wheel interface is of major importance to any analytical representation of vehicle performance. Therefore, mathematical models of the soil-wheel interface mechanics were developed, incorporating as much realism as possible, for three terrain classes: (1) undulating rigid terrain; (2) rigid obstacles and (3) soft, smooth terrain.

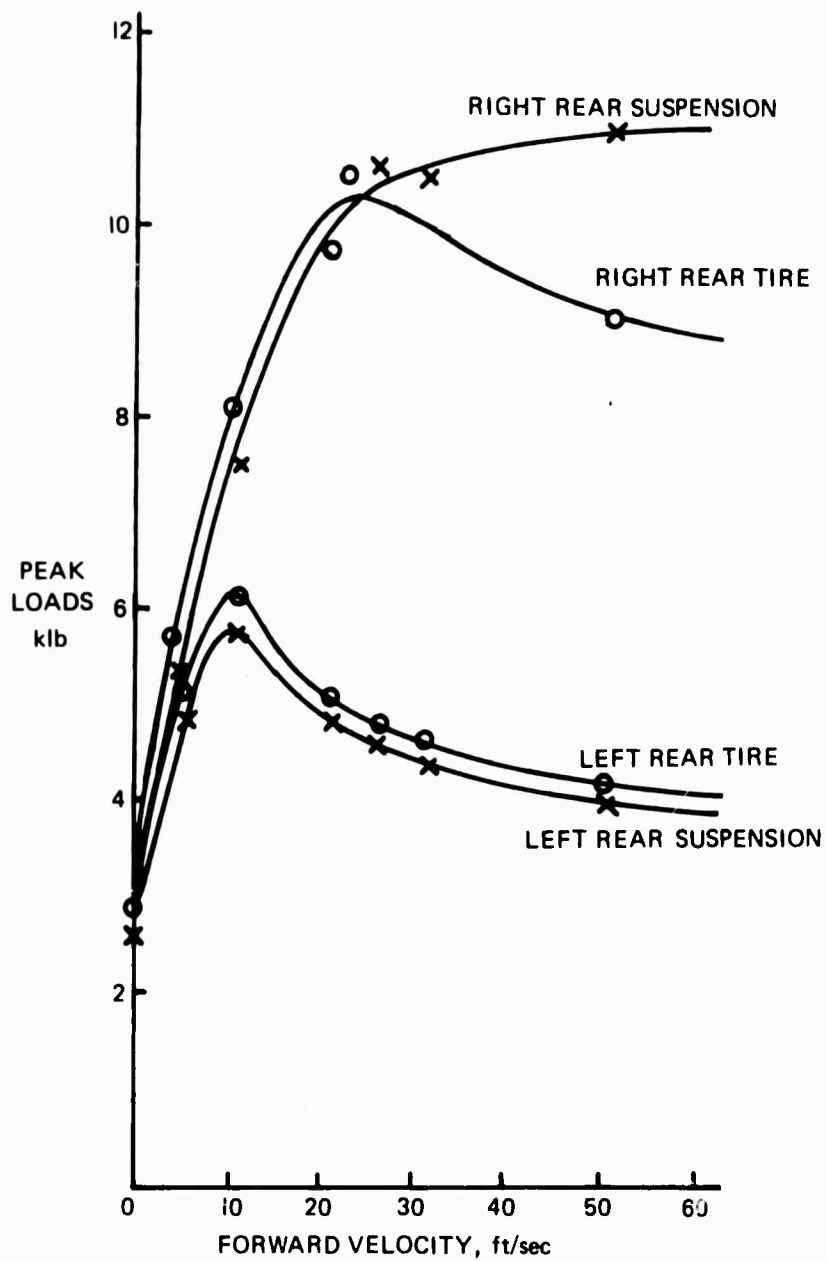

Figure 5 SUSPENSION AND TIRE PEAK LOADS VS FORWARD VELOCITY

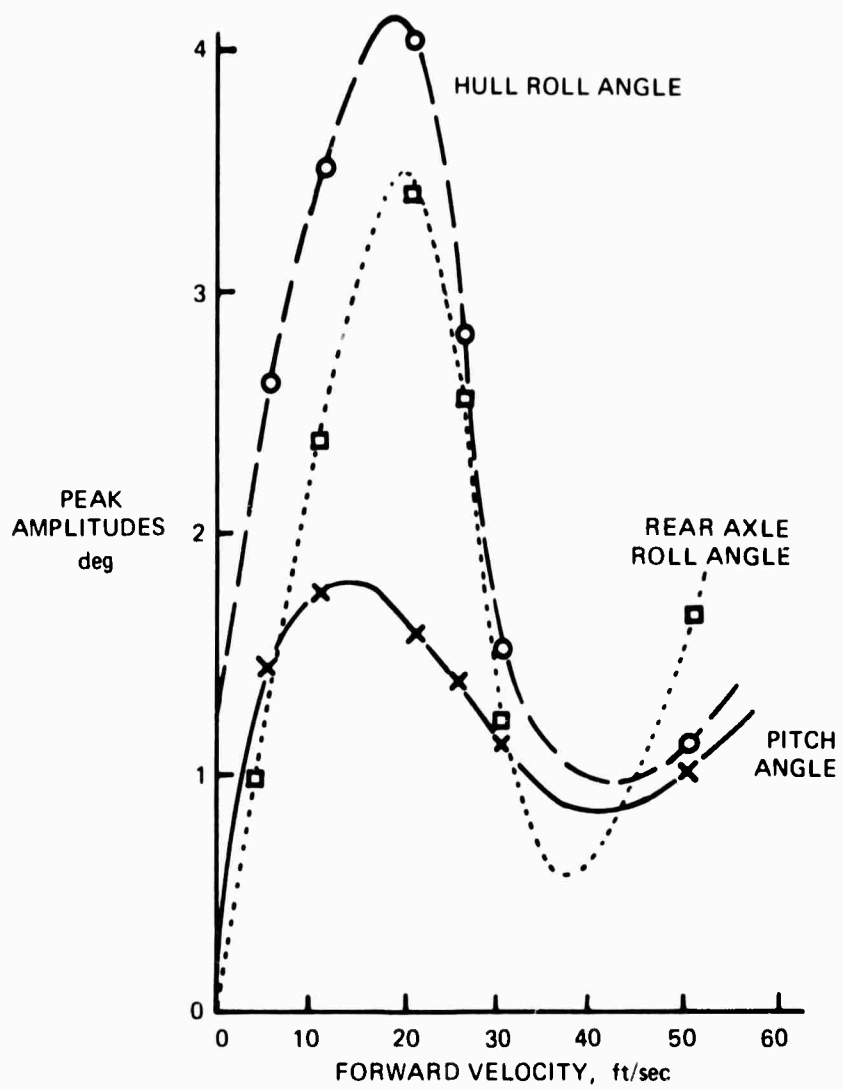

Figure 6 ANGULAR PEAK MOTION AMPLITUDES VS FORWARD VELOCITY

Each of the three terrain classes listed above is associated with a special mathematical wheel model designed to keep the mathematical effort as small as possible consistent with allowable deviation from true wheel performance.

In the development of the models, each of the vehicle wheels was considered to be a planar free-body and to have two degrees of freedom with respect to the vehicle hull: one being heave normal to the hull, the other being rotation around the axle. Further, it was assumed that the radial deflection of a wheel due to load is always small compared to the radius, so that the deflected radius at the contact area is approximately equal to the radius of the undeflected wheel.

Equations of equilibrium were derived from the consideration of a wheel as a free-body. A normal force and a thrust force act at the wheel-ground interface. Inertial forces, hub forces, weight components, driving torque, rotational moment of inertia, and moment of axle friction acting at the axle counteract the forces developed at the interface. A moment due to rolling resistance is introduced, where appropriate, by using the product of the (empirical) coefficient of rolling resistance,  $\rho$ , and the deflected radius as the moment arm for the normal force.

Wheel-ground interface for undulating, irregular surfaces - The mathematical model of this terrain simulates softly rolling hills with superimposed irregularities whose shortest wave length is larger than the length of the footprint. The terrain slope changes slowly with respect to wheel speed, that is, the product  $v(d\alpha/dX)$  is small, where;  $v$  = vehicle speed,  $\alpha$  = slope angle, and  $X$  = earth fixed coordinate in the direction of motion.

The roughness of an irregular surface can be described quantitatively in terms of its power spectral density (PSD). Figure 7 represents the PSD-curves of 25 terrains and roads. The ordinate has units of ft/cycle and the abscissa--spatial frequency--has units of cycle/ft. The area under the PSD-curve represents the mean square value of terrain roughness.

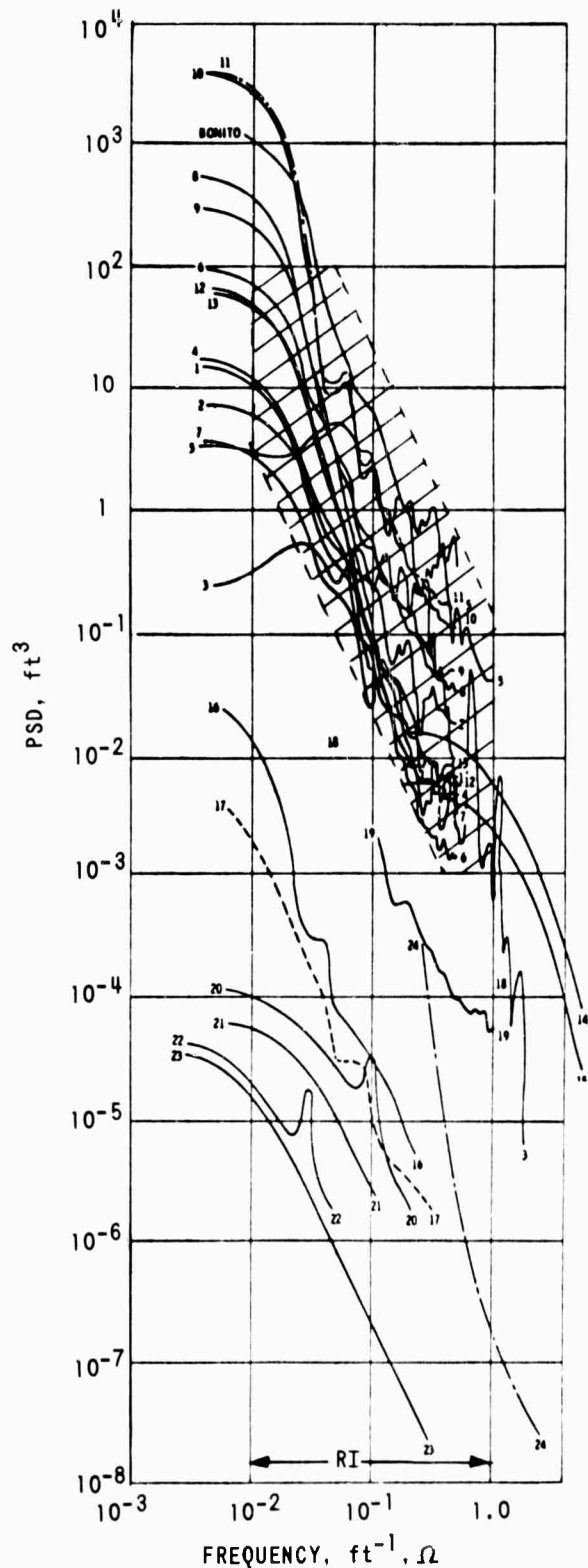

NO.	TERRAIN	REFERENCE
1	MILD ROUGHNESS	10
2	ROCKY SOIL	
3	CULTIVATED FIELD	
4	CROSS COUNTRY, MEDIUM ROUGHNESS	
5	ROCK AND LOG, ARTIFICIAL	
6	PERRYMAN CROSS COUNTRY	
7	GRASSLANDS	
8	CROSS COUNTRY MARKER 19	
9	TURN OFF TO MARKER 6	
10	VIRGIN TERRAIN, TRACK 1	
11	VIRGIN TERRAIN, TRACK 2	
12	CROSS COUNTRY, SEVERE ROUGHNESS 1	↓
13	CROSS COUNTRY, SEVERE ROUGHNESS 2	10
14	ARTIFICIAL	11
15	ARTIFICIAL	11
16	POOR RUNWAY	12
17	GOOD RUNWAY	12
18	POOR RUNWAY	13
19	GOOD RUNWAY	13
20	POOR COBBLED PAVEMENT	14
21	GOOD COBBLED PAVEMENT	14
22	ASPHALT PAVEMENT	14
23	CONCRETE ROAD	14
24	ASPHALT ROAD	15
	BONITO LAVA FLOW	11

RI = FREQUENCY RANGE OF INTEREST  
FOR OFF-ROAD LOCOMOTION  
(SEE EXAMPLE IN TEXT)

CROSS-HATCHED AREA = AREA OF  
INTEREST FOR OFF-ROAD  
LOCOMOTION

Figure 7 PSD CURVES FOR VARIOUS GROUND SURFACES

It is noted that the two terrain profiles underneath the left and the right side of a vehicle are somewhat correlated. The extent of track correlation has yet to be investigated and has not been taken into account. Instead, the assumption is made that the two tracks are completely uncorrelated. This means that each of the terrain profiles is represented by the same PSD-curve and exhibits the same statistical properties.

The range of spatial frequency and the spectral levels of interest depend on the natural frequency, the maximum velocity and the size of the vehicle. This dependency is demonstrated by the following example.

Given:            Lowest natural frequency of the vehicle-approximately 1 cps  
                  Maximum footprint-1 ft  
                  Maximum speed on random terrain-approximately 20 ft/sec  
                  Wheel diameter-3 ft

Frequencies below approximately 0.2 cycle/sec will scarcely affect dynamic vehicle performance. The maximum wave length of interest is therefore

$$\lambda_{\max} = \frac{20 \text{ ft/sec}}{0.2 \text{ cycle/sec}} = 100 \text{ ft/cycle}$$

or

$$\text{Max wave length/wheel diameter} = 3$$

Wavelengths shorter than the footprint will be felt by the vehicle only if associated with amplitudes large enough to cause multiple contact of the wheel. Otherwise, they will be enveloped by the wheel. A study of various terrain PSD-curves reveals very little power at wavelengths smaller than approximately 1 ft. Hence, terrain perturbations with wavelengths smaller than the footprint will not indent the wheel significantly. Consequently, the minimum wavelength of interest is approximately 1ft.

The range of interest of spatial frequency lies between 1 cycle/ft and 0.01 cycle/ft. Frequencies smaller than 0.01 cycle/ft can be pictured as rolling hills which have little effect on vehicle dynamics.

Randomly distributed surface irregularities can be implemented on an analog computer by using a white-noise source with filters approximating the desired power spectral density. The time delay between front and rear wheels can be simulated by utilizing a second-order Padé approximation.

A sketch of a wheel, traversing the undulating, rigid terrain just described, and the forces on the wheel is given in Figure 8. For this case, there is no wheel sinkage. The wheel is assumed to behave essentially as a single, radial spring with a load deflection curve synthesized from a loading test of the tire. The spring force is always directed normal to the ground. The force,  $N$ , is a function of wheel deflection; the thrust force,  $T$ , is calculated by assuming that dry-friction relationships apply between the wheel and ground, i.e.,  $T = \mu N$ , where  $\mu$  is a function of the slip between the wheel and ground.

Wheel-ground interface for rigid obstacles\* - The rigid obstacles in the mathematical simulation include rocks, ditches, logs and in fact all sudden changes in elevation with the exception of vertical walls (steps) higher than one-half the radius of a wheel.

Again, there is no wheel sinkage. This wheel is assumed to behave as an array of radial springs enveloped by an elastic band. Elastic properties of the wheel are representative of those of the real tire. Computation of normal (to an equivalent contact patch) and resultant thrust forces,  $N$  and  $T$ , is based on the wheel's deformation area and on the angular change of the obstacle's contour, see Figure 9.

---

\* A detailed description of this model was presented at the First International Conference on Vehicle Mechanics at Wayne State University, Detroit, Michigan, July 16-18, 1968, - "Prediction of Wheel Performance on Soft and Rigid Ground", by D. J. Schuring.

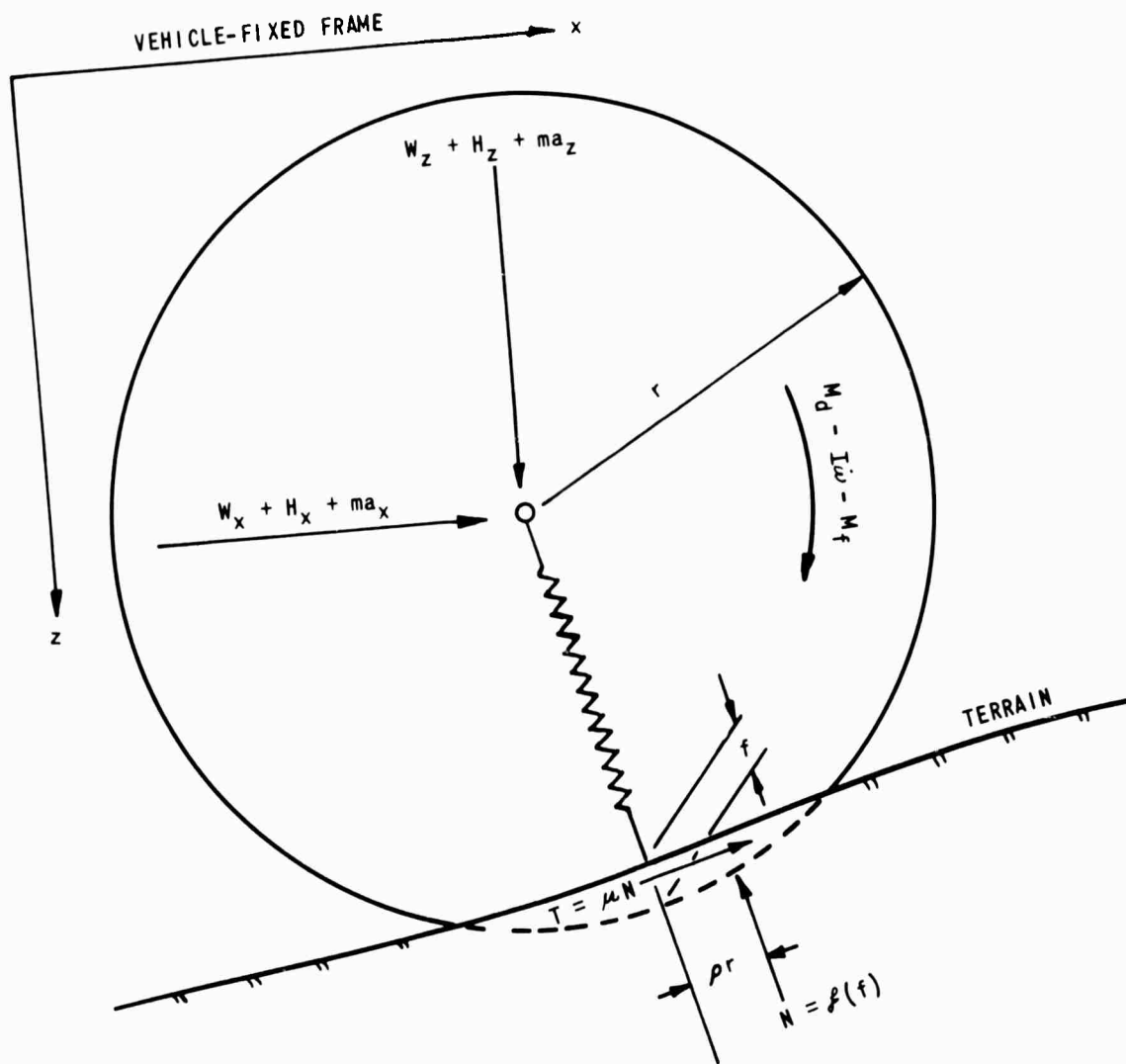

- $N$  = RESULTANT NORMAL FORCE AT INTERFACE
- $T$  = RESULTANT THRUST FORCE (PERPENDICULAR TO  $N$ ) AT INTERFACE
- $W_x, W_z$  = WHEEL WEIGHT
- $H_x, H_z$  = HUB FORCES
- $ma_x, ma_z$  = WHEEL INERTIA FORCES
- $M_d$  = DRIVING TORQUE
- $I\dot{\omega}$  = WHEEL INERTIA MOMENT
- $M_f$  = AXLE FRICTION MOMENT
- $\rho$  = COEFFICIENT OF ROLLING RESISTANCE
- $f$  = MAXIMUM DEFORMATION
- $\mu$  = COEFFICIENT OF FRICTION

Figure 8 FORCES AND MOMENT AT HUB AND WHEEL-GROUND INTERFACE -  
UNDULATING, RIGID TERRAIN

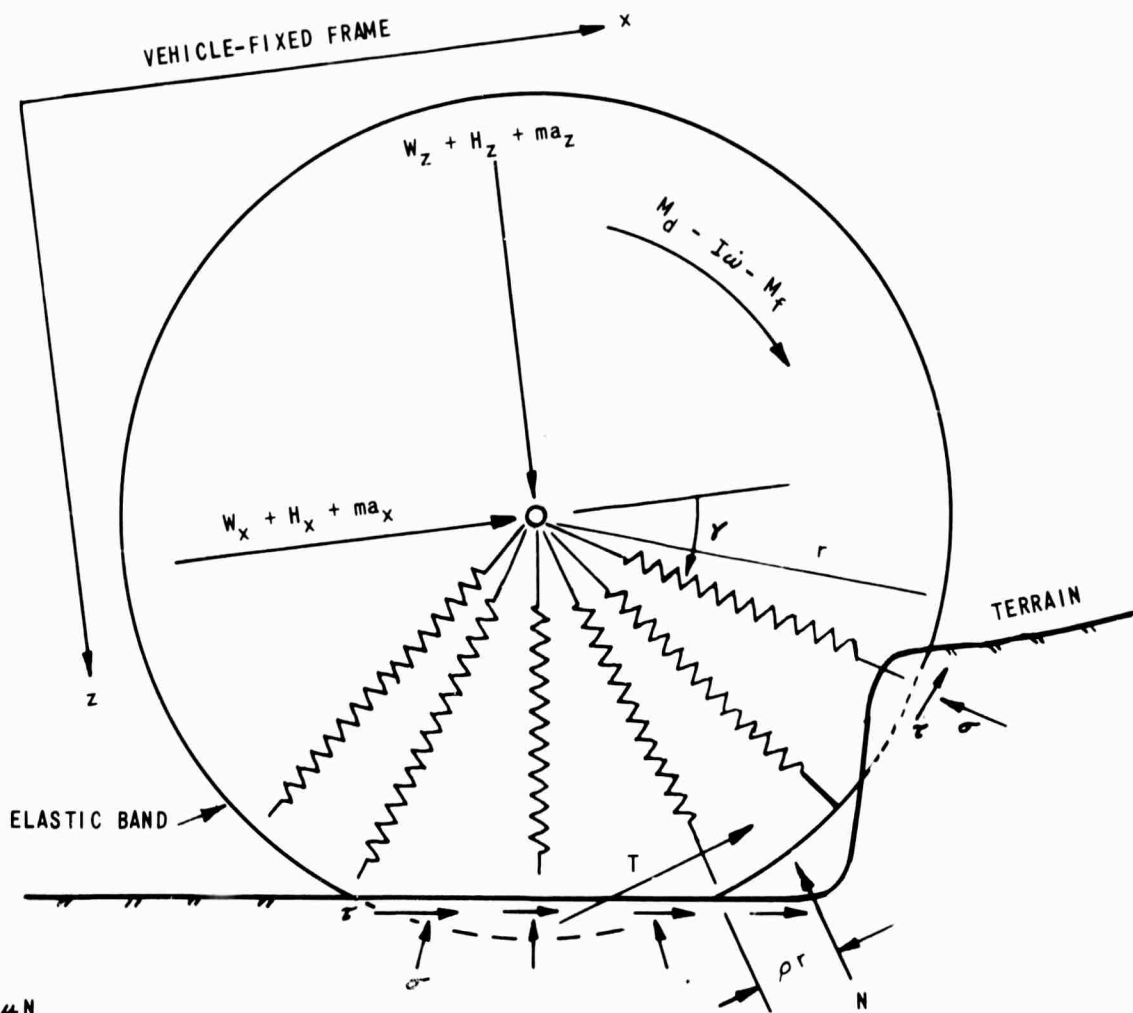

$$T = \mu N$$

$$N = rb \sqrt{\left[ \int_0^{\pi} \sigma \cos \gamma d\gamma \right]^2 + \left[ \int_0^{\pi} \sigma \sin \gamma d\gamma \right]^2}$$

$\sigma$  = RADIAL STRESS

$\tau$  = TANGENTIAL STRESS

$\gamma$  = WHEEL ANGLE

$b$  = WHEEL WIDTH

NOTATION AS IN FIGURE 8

Figure 9 FORCES AND MOMENTS AT HUB AND WHEEL-GROUND INTERFACE - OBSTACLE

The radial displacement,  $f$ , of the wheel traversing a single obstacle can be measured on an analog computer by a sweeping ray rotating around the wheel center, see Figure 10. The angular speed of the sweeping ray is very large with respect to the wheel angular velocity. This permits the computation of  $f(\gamma)$  with negligible forward movement of the wheel during each rotation of the sweeping ray. Since the contour of the obstacle is generated by function generators, the radial deformation can be measured essentially continuously. For all but wall-like obstacles with a height larger than half the wheel's radius, the intersection between sweeping ray and obstacle contour, Point A in Figure 10, can be estimated without serious error by Point B shown in the figure. Then, the radial penetration can be approximated by solving the four following equations simultaneously (refer to Figure 10 for definition of symbols):

$$f \approx \frac{\Delta Z}{\sin \gamma}$$

$$\Delta Z \approx Z + r \sin \gamma - Z_t(X')$$

$$X' \approx X + r \cos \gamma - \Delta X$$

$$\Delta X \approx f \cos \gamma$$

The radial penetration,  $f(\gamma)$ , serves as basic input for the computation of wheel forces and, through these, the movements of the vehicle.

Wheel-ground interface for soft, smooth terrain - Mathematical simulation of this terrain allows for sinkage up to half the wheel's radius. The terrain slope is assumed to be of such magnitude that it can be neglected without serious error.

Resistance of soil to penetration and shear is computed using Bekker/LLL<sup>16</sup> relations.

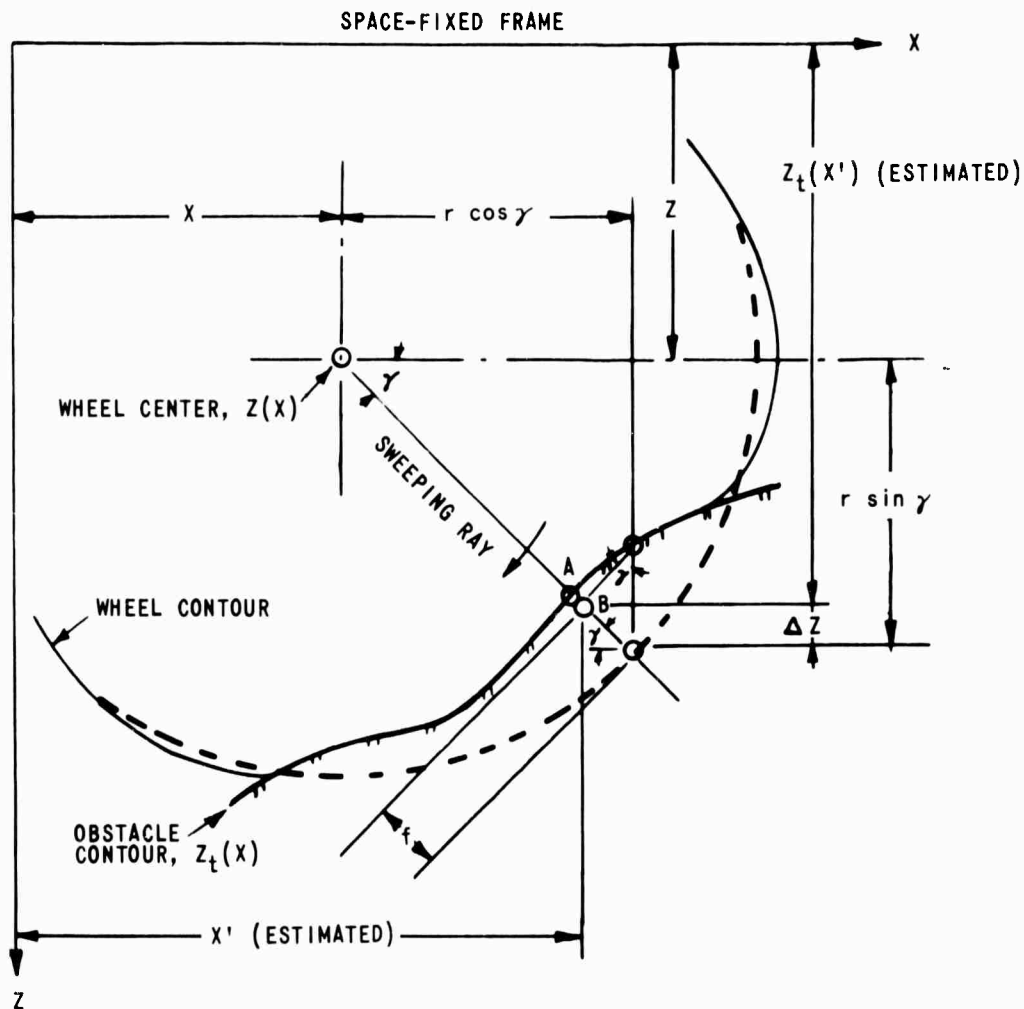

- $Z(x)$  = POSITION OF WHEEL CENTER
- $\gamma$  = MOMENTARY POSITION OF SWEEPING RAY
- $f$  = ESTIMATED RADIAL DISPLACEMENT OF WHEEL
- $Z_t(x)$  = CONTOUR OF OBSTACLE
- $r$  = UNDEFORMED WHEEL RADIUS
- A = REAL INTERSECTION BETWEEN SWEEPING RAY AND TERRAIN CONTOUR
- B = ESTIMATED INTERSECTION

Figure 10 GEOMETRY OF WHEEL-OBSTACLE INTERFACE

To render the complex relations between the elastic wheel and soft soil amenable to implementation on the computer, the following assumptions have been made:

(1) The radial soil pressure,  $\sigma$ , cannot exceed the internal wheel pressure,  $p$ , see Figures 11 and 12.

(2) The radial soil pressure,  $\sigma$ , is distributed symmetrically along the contact region in the form of a triangle or a trapezoid, see Figure 12.

(3) Deformation of the wheel depends on internal pressure and on softness of the soil. The wheel is treated as a rigid body for  $\sigma_{max} \leq p$  ( $p$  = internal tire pressure,  $\sigma_{max}$  = external, maximum radial stress at interface). It starts deforming if  $\sigma_{max} > p$ , as indicated in Figure 12. Computation of  $\sigma_{max}$  is based on a modified Bekker/LLL approach.

$$\sigma_{max} = \left( \frac{k_c}{b} + k_\phi \right) z^n$$

where  $z$  is the sinkage at  $\gamma = \frac{\gamma_1 + \gamma_2}{2}$ ,  $k_c$ ,  $k_\phi$  and  $n$  are soil values, and  $b$  is the wheel's width.

(4) The tangential soil stress,  $\tau$ , reacted by the wheel, is a function of: radial pressure,  $\sigma$ ; the relative displacement between soil and wheel,  $j$ , in the interface; and soil values. According to Bekker, Janosi and Hanamoto<sup>17</sup>, this function is

$$\tau = (c + \sigma \tan \phi) (1 - e^{-j/k})$$

where  $c$  = soil cohesion,  $\phi$  = angle of internal soil friction, and  $k$  = soil slip parameter.

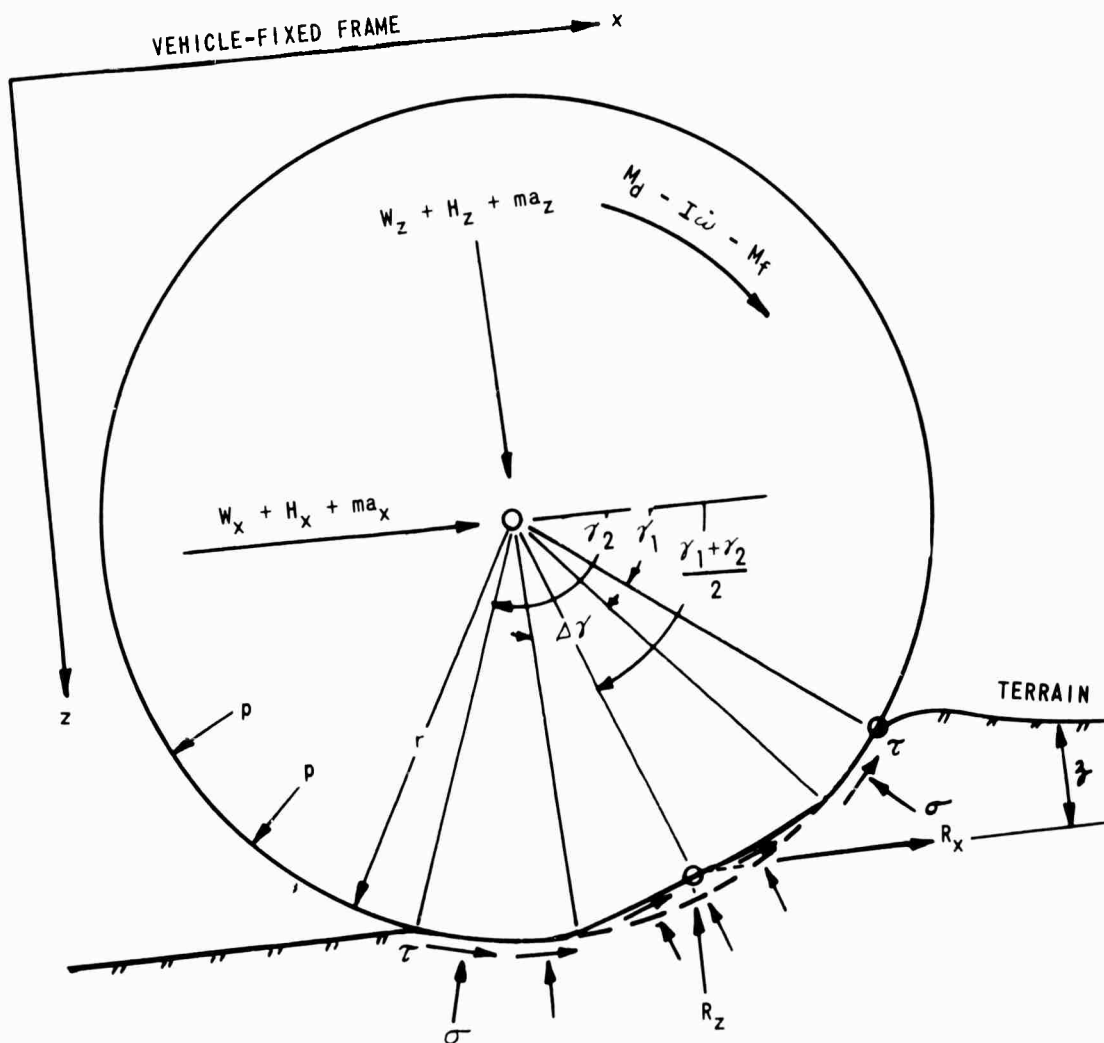

$p$  = INTERNAL WHEEL PRESSURE  
 $R_x$  &  $R_z$  = COMPONENT OF RESULTANT FORCE AT INTERFACE  
 $z$  = SINKAGE  
 $R_z = \frac{1}{2}brp(\gamma_2 - \gamma_1 + \Delta\gamma)$   
 ALSO NOTATION AS IN FIGURES 8 AND 9.

Figure 11 FORCES AND MOMENTS AT HUB AND WHEEL-GROUND INTERFACE - SOFT, SMOOTH SOIL

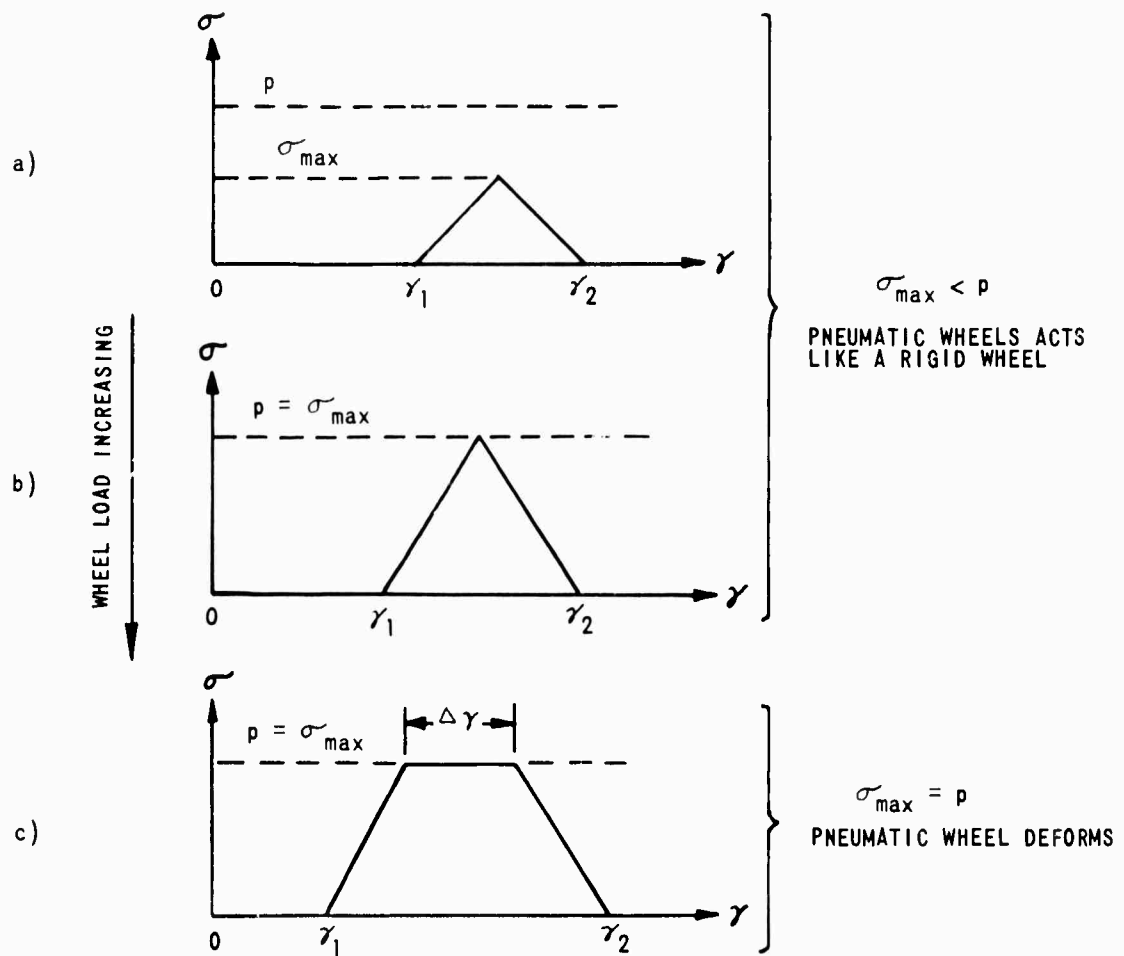

Figure 12 PNEUMATIC WHEEL ON SOFT SOIL -  
THREE STAGES OF RADIAL STRESS DISTRIBUTION

(5) Tangential soil flow in the interface is neglected. Then, the displacement between soil and wheel is

$$j = r [\gamma - \gamma_1 + (1-i)(\cos \gamma - \cos \gamma_1)]$$

where  $i$  = wheel slip,  $\gamma_1$  = front angle of contact,  $r$  = wheel radius.

A computer model has been formulated according to these assumptions, which allows the computation of axle forces, slip and driving torque in accord with the remainder of the vehicle dynamics equations.

#### 3.2.1.3 Model Verification Tests

Particular aspects of the vehicle dynamics model which are of prime interest in the prediction of mobility, and which have been selected for initial verification, are those that deal with vehicle dynamic response in specified terrains. The Pleuthner report<sup>18</sup> has shown that a comprehensive review of drawbar pull tests (an area where extensive testing has been done, and a large amount of statistical data exists) has led previous researchers to conclude that the effect of vehicle design parameters on mobility is (a) extremely important and (b) not well understood, with no prediction method and corresponding set of verifying tests existing. Included among the particular vehicle parameters which have been identified as having a large (but quantitatively unknown) effect on traction capability are: suspension spring constants and damping, particularly in areas of soft and/or slippery terrain having irregular contours and unhomogeneous properties; vehicle drive train torque-slip characteristics; vehicle clearance dimensions; and sensitivity of throttle control. The performance prediction model has been designed to investigate just these kinds of effects and a verification test program was initiated wherein vehicle field tests would be run with an instrumented M715 utility truck. The test results will then be compared with computer runs having identical terrain inputs, vehicle initial velocities, etc.

In order to obtain the maximum degree of correspondence between the computer runs and the verification tests, several necessary pretest tasks have been accomplished and are described below.

Those component characteristics that are known by the manufacturer have been obtained. Moreover, to provide the necessary information on characteristics that are not known, and to verify certain of the values that are thought to be known, the following vehicle data have been obtained by testing and measurement at CAL:

1. Weight of vehicle
2. Weight of wheel-tire assembly
3. Weight of front and rear axle assemblies (including wheels and tires)
4. Dimensional data for spring, shock absorber and upper bumpstop locations
5. Longitudinal location of c.g. of unladen vehicle
6. Force-deflection characteristics of leaf springs -- including hysteresis curves.

Testing procedures have been defined, and hardware has been designed and provided (in the form of loading fixtures) for the following vehicle component tests:

- (a) Fore and aft drop test with shock absorbers for pitch damping determination.
- (b) Roll displacement tests to measure roll center location, roll inertia, roll damping and frame torsional rigidity.

- (c) Loading of front and rear upper humpstops to obtain force-deflection characteristics.
- (d) Tilt platform test for vertical c.g. location.
- (e) Weighing for lateral c.g. location.

The vehicle has been equipped with the following instrumentation:

1. Three axis integrated accelerometer package with amplifiers.
2. Wheel deflection linear potentiometers, 10 in. stroke; four wheels.
3. Strain gage type accelerometers, one each end of axle -- front axle acceleration.
4. Damper force transducers; strain gages bonded to shock absorber struts; four units.
5. Power supply; battery pack and DC-AC inverter.
6. 18-channel oscillograph.
7. Roll and pitch rate gyros--sprung mass.
8. Roll and pitch attitude gyros-- sprung mass.

The plan specifies "bumps" of two configurations: sinusoidal (single-cycle **one** minus cosine) and half cylinder. These have been fabricated. The sinusoidal hump has a height of **six** inches and a length of 60 inches. The half-cylinder is of six inches radius.

The test planning and the vehicle component testing and design acquisition, vehicle instrumentation, calibration and fabrication of field test hardware have been carefully accomplished with the aforementioned goal in mind -- the verification of the computer model, with emphasis on the effect of vehicle design parameters on mobility. The work already accomplished on the computer model and in the verification test program have set the stage for parallel running of the performance prediction model and the corresponding verification tests. Thus, it is anticipated that this next phase of research, when continued, will be extremely productive in terms of providing the first quantitative analysis and verification of the effect of a complete set of vehicle parameters on vehicle mobility.

### 3.2.2 Evaluation of Existing Quantitative Methods of Predicting Vehicle Traction, Soil Resistance, and Trafficability

The aim of this task was to perform an objective and systematic evaluation of existing theory and practice in predicting vehicle trafficability off-the-road. The method used in carrying out this objective was to make direct comparisons between the results obtained from full scale tests and those obtained from calculations using quantitative predictive theories. An attempt was made to produce clearly defined limitations of the currently used theories as they relate to accuracy and range of applicability to different soils and specified ground contact elements.

Since the results of this study are published <sup>18</sup> it will suffice to present a condensation of the material here.

A large amount of literature pertaining to testing and performance prediction was reviewed and grouped into four broad categories: (1) full scale vehicle field tests, (2) single wheel tests (field and soil bin), (3) soil strength measurement techniques, and (4) prediction theories and methods.

The bulk of the material in Reference 18 covers full scale vehicle field tests, although there are some data given for full scale vehicle soil bin tests. It was not possible to treat the large amount of available data on single wheel tests -- this is something that should be done in the future, however. Soil strength measurement techniques and the substance of the currently used predictive theories are discussed in Reference 18 only in sufficient depth to give the reader a good understanding of how one calculates the performance parameters needed for comparison with test results. The theories covered included the Bekker/LLL theory<sup>16,19,20,21,22</sup> the "standard" WES Cone Index method<sup>23,24</sup> the Nuttall-WES Cone Index method,<sup>25</sup> an analytical method developed by Perloff for tracked vehicles<sup>26</sup> and theories developed by Reese and his co-workers.<sup>27,28,29,30</sup>

#### 3.2.2.1 General Comments on Test Programs

The most frequently measured performance variable in the field tests which were reviewed was maximum drawbar pull. In some cases slope climbing ability and maximum speed tests were also reported. In only one case (in the literature reviewed) was soil resistance measured.

Evidence of numerous deficiencies in current field test practices was uncovered in the course of performing this study. Some of the deficiencies are discussed here and also in section 3.2.3 of this report. There is little or no standardization of testing methods, procedures, or instrumentation. Standardization is also lacking in the measurement of soil strength and sinkage parameters (the adoption of SAE Recommended Practice J939<sup>31</sup> should help relieve this situation). Severe space gradients in soil values for a given test lane, varying moisture content and surface vegetation, pressing time schedules, and driver variability are some of the other factors that have contributed to the problem of maintaining good control over field tests.

The shortcomings of the test reports themselves included omission of pertinent measurements (e.g., slip values), incompleteness, and uncertainties about the particular equations used to make predictive calculations. Despite these shortcomings, however, it is believed that the results achieved are useful.

### 3.2.2.2 Data Analysis

For a given set of data with sample size  $n$  (for example,  $n$  vehicles) the measured value of the performance variable of interest is designated  $M$  and the predicted (i.e., calculated) value  $P$ . The difference,  $M-P$ , is denoted  $\Delta$ . Note that  $\Delta$  is not an error in the sense that it is the difference between a true (measured) value and a predicted value--the measured value is itself highly suspect in many cases. It can be thought of as a measure of the agreement between a measured value that is generally imperfect and a predicted value that may be a priori imperfect.

The quantities that have been chosen as mathematical descriptors in the evaluation process are:

$\left(\frac{\bar{\Delta}}{M}\right)$  The sample mean of the ratio of  $\Delta$  to  $M$ ;  $\Delta/M$  is similar to an "error" ratio.

$\sigma\left(\frac{\Delta}{M}\right)$  The standard deviation of  $\Delta/M$  about the sample mean. If  $M$  is without error then  $\left(\frac{\bar{\Delta}}{M}\right)$  can be considered a measure of the accuracy of the prediction and  $\sigma\left(\frac{\Delta}{M}\right)$  a measure of its precision.

$$E\left(\frac{\Delta}{M}\right) = \left[ \left(\frac{\bar{\Delta}}{M}\right)^2 + \sigma\left(\frac{\Delta}{M}\right)^2 \right]^{\frac{1}{2}}$$

A measure of the "goodness" of  $\Delta$ . Small  $E(\Delta/M)$  implies both accuracy and precision.

### 3.2.2.3 Test Programs

In reference 18 each test program for which reported data were extracted and analyzed is described in some detail. The specific tests that were conducted are described, the participating agencies identified, the

number and types of vehicles involved are given, and the soil measurements taken and other pertinent information are noted. The test programs covered include:

- (1) Project Wheeltrack I (Reference 32 )  
Fort Story Moist Sand Tests  
Messick Marsh Tests
- (2) Swamp Fox II Exercises (Reference 33 )  
Area A (fine-grained soil)  
Area B (cohesive soil)  
Area D (clay soil)
- (3) WES-Nuttall One-Pass Test Program (Reference 25 )  
Lake Centennial  
Grenada Lake  
Fort Stewart  
Camp Shelby  
Vicksburg
- (4) MERS One-Pass Exercise (ATAC) (Reference 34 )  
Lake Centennial  
Grenada Lake
- (5) ATAC Snow Tests (Reference 35 )
- (6) ATAC Full Scale Vehicle Soil Bin Tests (Reference 20 )
- (7) ATAC Tracked Vehicle Speed Tests (Reference 36 )
- (8) WES Single Wheel Soil Bin Tests

#### 3.2.2.4 Results

Computed values of  $(\bar{\Delta}/M)$  ,  $\sigma_{(\Delta)}$  , and  $E(\Delta/M)$  . together with the range of values encountered for the parameter  $\Delta/M$  , are given in Tables B-1 to B-6 in Appendix B for the various test programs covered. Some comments on these results follow.

The data classified according to test program in Table B-1 has been reclassified according to prediction method and soil classification in Table B-2. In Table B-2 various group summaries of drawbar pull divided by weight are given. Note first that in all some 502 tests are covered (first row, Table B-2). On the basis of all tests (regardless of vehicle type, soil type, etc.) the Bekker/LLL method provides a slightly better prediction than the Cone Index method (row 3;  $E(\Delta/M) = 0.50$  vs  $0.68$ ). There are two groups of data having noticeably good results--the Bekker/LLL sheargraph predictions for both wheeled and tracked vehicles in clay loam ( $E(\Delta/M) = 0.25$ ). The excellent sheargraph results are attributed to the use of a smooth rubber shearhead on the slippery clay-loam.

It must be remembered that for the majority of tests the full Bekker/LLL theory was not used. Generally, the slip function was assumed to be unity; the exception being the MERS one-pass program. Plate sinkage tests were made only in the Wheeltrack I and ATAC snow tests. For all others, compaction and bulldozing resistances were neglected as being negligible or for no apparent reason. One must conclude that these field tests and predictions do not provide a good basis to assess the theory's validity. On the other hand, for the soil bin tests of full scale vehicles listed in Table B-6, the full Bekker/LLL theory including computer solutions was used. Predictions are quite good ( $E(\Delta/M) = 0.23$ ).

The gradeability tests listed in Table B-3 show the Bekker/LLL predictions using the sheargraph to be far superior to those using the Standard Cone Index method for the same reason as that for superior drawbar pull on slippery soil.

Tests of soil resistance to motion and predictions using the WES-Nuttall analysis are listed in Table B-4. The results are poor and become more so with decreasing relative surface soil strength.

Two groups of speed prediction tests are listed in Table B-5. Liston's method using the Bekker/LLL method gives far superior predictions than does the WES-Nuttall one-pass analysis. However, direct comparison cannot be made because different vehicles were tested on different soils and grades.

It is concluded that better results for the performance prediction of drawbar pull, gradeability and speed are obtained using the Bekker/LLL method. The difficulties associated with a heavy vehicle-mounted Bevameter should be overcome now that a portable instrument is available. However, reported results of its use in the field are very limited. For situations involving slippery soils with negligible sinkage, use of the sheargraph with a flat shearhead resulted in excellent predictions.

It is pointed out that the Bekker/LLL method is partly empirical and has as its basis the Mohr-Coulomb shear theory of foundation soil mechanics and the penetration or sinkage concepts of Bernstein.

### 3.2.3 Full Scale Mobility Test and Evaluation Practices

The objective of this study was to review and to critically examine current practices in off-road vehicle testing and evaluation. The study was conducted in three parts:

- (1) A survey of available literature was made and conclusions drawn with respect to the current status of the full scale mobility testing of off-road vehicles,

- (2) Methods for the improvement of current testing practices were studied, and
  - (3) Areas of research that are considered to be essential to the development of unified testing practices were identified.
- The results of these investigations are given below.

The basic authorizing document which establishes procedures that eventually result in test and evaluation practices is AR 705-5,<sup>37</sup> "Research and Development of Materials, Army R&D." This document is applicable to other types of materiel as well as to off-road vehicles. AR 705-5 establishes the Qualitative Materiel Requirement, or QMR, as the formal document for setting forth and justifying the need by the Army for a particular type of materiel. A detailed procedure for processing the QMR is described from its initiation, based on needs established by the Army, through several screening and approval steps, to assignment for development by the Army Materiel Command (AMC). Many persons become involved in all aspects of vehicle requirements and changes can and are made to the QMR as originally submitted. Headquarters, Department of the Army, assigns a development project number, designates responsibility for development of the QMR, and work begins.

The QMR, as finally approved, is the governing document. At this point the argument is raised that if the QMR is too restrictive, freedom of design or innovation are lost since the vehicle has already been "designed" by constraint. Development and design personnel--it is argued--can only try to resolve conflicting requirements by trade-offs, which must be subsequently approved by all the various agencies having an interest in the vehicle.

From the time that a "test bed" or development prototype is produced until approved vehicles roll off a production line, many tests are conducted on individual components and kits as well as on the complete vehicle. All

of these tests must meet the requirements set forth in the QMR as finally approved, or as modified after approval by all concerned. For example, the Infantry Test Board has three types of major tests and ten sub-tests, the plans for which are formulated by a test board based on QMR's and generated by the Combat Development Command (CDC). The three major types of tests are:

- 1) Military potential tests
- 2) Service tests (R&D tests)
- 3) Confirmatory tests based on production models

The ten sub-tests are:

- |                             |                               |
|-----------------------------|-------------------------------|
| 1) Maintenance              | 6) Pre-operational inspection |
| 2) Cross-country durability | 7) Safety                     |
| 3) Human factors            | 8) Training requirements      |
| 4) Value analysis           | 9) Kit qualification          |
| 5) Functional suitability   | 10) Performance mobility      |

The foregoing, while necessarily oversimplified, is presented to establish the proper perspective for mobility testing and evaluation relative to the total testing effort required in today's complex military vehicle. While the following remarks are primarily concerned with mobility, it is appreciated that much more is involved in the end product.

### 3.2.3.1 Literature Survey and Conclusions

The literature surveyed represents a cross-section of past and current off-road mobility vehicle testing as practiced by the several agencies involved. The time period covered is from about 1958 to 1967. Following are the basic conclusions reached. Pertinent comments appear in Appendix C.

1. Many recognized authorities are in agreement that current practice in the mobility testing and evaluation of off-road vehicles is unsatisfactory. Opinions vary as to what constitutes "unsatisfactory".
2. Specific programs that have been proposed at the conclusion of extensive projects have either not been acted upon (to our knowledge) or are slow in being implemented and reported upon.
3. A communications gap exists between the theorists or experimenters and the production-type testers or users.
4. Testing by the "experimenters" suffers from diversification of effort, "special case" testing, and too little concrete data upon which to confirm results.
5. Testing by "production-type testers" suffers from poor definition of the environmental profile for which the vehicle is intended.

#### 3.2.3.2 Recommendations for Improvement of Test Practices

Our studies of the methods by which current test practices might be improved resulted in the recommendations listed below. The recommendations are discussed in Appendix C.

1. Standardize test methods and practices. It is suggested that the Army Test and Evaluation Command be responsible for providing appropriate Materiel Test Procedures for off-road mobility evaluation testing and that these documents become the standards referenced and used by the many military agencies concerned with vehicle mobility specification and measurement.

2. Specify environmental profile for vehicles. QMR's should specify in as much quantitative detail as possible the environmental parameter limits which the vehicle is to be designed to meet. These will be the basis for future test methods.
3. Generate reliable environmental data during testing. Tests not conducted on roads should contain test data adequately describing the environment in which the test was carried out. "Adequacy is a function of the kind of environmental tests, their spatial distribution (sampling) and the number of specimens or individual tests made." Statistical assistance should be sought in determining this if it is not specified in the vehicle test procedure.
4. Reduce subjectiveness of reporting the mobility of a vehicle. Report aspects of mobility in some quantitative rather than qualitative fashion, where possible. For example, report time to cross an obstacle rather than relative "ease" of overcoming it.
5. Plan field mobility exercises carefully enough to provide adequate time and facilities for sufficient and meaningful measurements of mobility parameters to be made during the exercise. This is not only basic to justifying the cost of the exercise, but can provide a needed basis for bringing theory closer to practice.
6. Include stream crossing test facilities at appropriate testing grounds. This obstacle is a prime one in the field and no standard test nor facilities currently exist.

### 3.2.3.3 Proposed Areas for Research

#### 1. Identification of the Set of Vehicle World Environmental Analogs

For vehicles operating on the surface of the earth, it is postulated that there exists a finite collection of elementary environmental conditions which span the world environment. These elementary environmental "classes" are distinguished from each other by degrees of severity of various factors affecting vehicle performance. Any given regional environment then consists of a combination (i.e., union) of certain of these elementary classes. It is proposed that this approach be investigated to determine if a "manageable" number of such classes, which are realistic, can be identified. If so, they would then constitute a set of environments from which subsets could be selected for application to vehicle testing in accordance with the particular environment on that part of the earth for which evaluation is desired. As a corollary, such subsets could constitute a check list or guide for environmental reconnaissance operations.

Subsequent to proposing this research task, CAL embarked on such a study which has been reported in Reference 6 and is also discussed in section 3.3.2 of this report.

#### 2. Rationale for Selecting Environmental Classes for Test Purposes

Given that a set of environments can be successfully formulated, a rationale will then be required for selecting subsets for application to specific vehicle test procedures corresponding to specific applications. It is proposed that the development of such a rationale be a follow-on to the foregoing study. Such a rationale might be formulated by studying the set of environmental classes, extracting from them common factors and determining the range of severity existing for each factor on a world-wide basis. In

performing this operation, it would be necessary that all factors be suitably defined and that a basis for quantifying them--even on an arbitrary rating basis--be established. Quantification, in turn, would establish requirements for measurements and instrumentation, if no suitable instrumentation were already available.

### 3. Formulation of ORMR Tests

It is presumed that the foregoing research of extracting common environmental factors from the set of environmental classes would result in a "boiling down" effect which would yield fewer "factors" than "classes". The object of the Test Formulation research would be to combine "factors" in as few "Unit Tests" as possible, while maintaining the relevancy of the factors to the classes from which they come.

### 4. Valid Sampling of Environmental Descriptors

The value of many otherwise good tests is downgraded because of bias introduced through invalid sampling techniques. Since the nature of the environment often forces sampling methods to be used, it is felt that attention should be given to determining rules and procedures to be followed when the sampling of environmental descriptors is required.

### 5. Handling the "Operator Effect" in Vehicle Testing

In the final analysis, the test of a vehicle is conducted by the operator. So far as can be determined, this phase of testing has been assiduously avoided by those in charge of testing. It is a difficult problem and it should be attacked to complete the testing picture. At this time it is contemplated that an experimental design approach to separate out "operator effect" should be attempted, not a psychological testing program on operators.

## 6. Design and Analysis of Experiments

The analysis of test results in the evaluation of vehicle mobility is the pay-off of the test effort. How the results are analyzed can have profound effects on the conclusions; can sometimes yield additional information; can sometimes lead to fewer or less costly tests; and can provide a data base useful to the advancement of the state-of-the-art. The use of experimental design techniques in the planning and conduct of testing will result in more meaningful data analysis, since the two are interrelated.

### 3.3 ENVIRONMENTAL FACTORS

One of the basic elements on which the performance of an off-road vehicle depends is the degree to which it conforms to the environment through which it must pass. The relevant environmental factors--soil, terrain geometry, hydrology, vegetation, and cultural features--compose the terrasphere, the medium of land locomotion. To assess the degree of match or mismatch between vehicle and terrasphere requires the acquisition, analysis, and presentation of pertinent environmental and vehicular data.

Data acquisition presents a dilemma to the environmental scientist: he must often choose between breadth and depth in his understanding of nature. Methods of data acquisition which are capable of high precision and accuracy are often time-consuming and expensive; consequently, geographical coverage by such methods is extremely limited by available resources. Methods capable of broad coverage, on the other hand, must often sacrifice resolution in the interest of obtaining a more comprehensive view of the "big picture." The level of generalization appropriate in a given environmental analysis is often determined by the type of inquiry in hand, and it is for this reason that the full gamut of data-acquisition methods are of interest in off-road mobility studies.

Data analysis must supplement data acquisition; otherwise, reams of environmental data are of little value. In the case of off-road mobility research, environmental factors must be interpreted in terms of their effect on vehicle performance, and this interpretation presupposes some means by which the interaction between vehicle and terrain can be understood. Various methods are available for this purpose--mathematical analysis, computer simulation, physical simulation (scale modeling), and full-scale test--but all seek a common end, to express vehicle response as a function of environmental demand.

A well-known approach to the evaluation of systems is to identify unit inputs into which all inputs can be resolved. If the response of the system to each unit input can be defined, then the total response of the system can be postulated in terms of these unit responses. In the following discussion, a similar approach is considered for analyzing the performance of a vehicle system. In one application,<sup>38</sup> the connection between unit stimulus and unit response is based on simple mathematical computation. In recognition of the incompleteness of vehicle-terrain interaction theory, however, a procedure is outlined for providing this connection by way of full-scale tests in the interests of greater realism.<sup>6</sup>

Once environmental data have been acquired and analyzed in relation to a vehicle system, the task remains to present this information in a form useful for decision making at various echelons of command. Inasmuch as environmental challenge to a vehicle varies as a continuous function of geographic coordinates, vehicle performance can be regarded as a field, in the same sense as an electric, magnetic, or gravitational field. Such a field characterization, reflecting the location-dependent nature of mobility, is essential to a meaningful evaluation of the ability of a vehicle to perform a specific mission. This type of characterization requires data of small breadth and large depth and is of interest to the tactical unit commander. For higher echelon planning, however, it may be of more interest to aggregate missions and to employ an appropriate statistical process to evaluate the ability of the vehicle to perform in a collection or assemblage of missions. Inasmuch as aggregated performance can always be derived from sufficiently detailed location-dependent performance, the ability to map the performance field is considered basic to mobility analysis. In a later section, computer techniques for constructing such maps are presented and the relation of such maps to statistical aggregation briefly discussed.

### 3.3.1 Environmental Data Base for Off-Road Mobility

As the result of continuing efforts in a number of disciplines, an appreciable data base pertinent to the natural environment has accumulated.

Assessment of the available data base for purposes of off-road mobility research involves: (1) identifying the principal sources and formats of environmental data collection, and (2) evaluating the applicability of these data to problems of off-road mobility.

It is evident that only minute portions of the world have been inventoried at the level of detail needed for a complete analysis and prediction of vehicle mobility. (The Mobility Environment Research Study (MERS) study areas of Thailand perhaps come closest<sup>39</sup>). It is evident also that to prepare a quantitative inventory of terrain descriptors for extensive regions, methods must be developed for proceeding from a general level of terrain description as provided in the now-existing data base (i.e. pedologic soil surveys, geologic and physiographic maps and surveys, vegetation maps and descriptions, climatic records, air photos, topographic maps, etc.) to a more detailed level.

Recognizing that an extensive mobility-oriented data base does not exist in a form adequate for mobility-research purposes, one may ask how an appropriate data base may be acquired. In order to bridge this gap it is necessary to break down the entire environmental complex into units which contain spectrums of descriptor values which recur in a recognizable pattern on the land surface. We have chosen to call these recurrent units "unit environments". An individual unit environment will display distinctive probability distributions of descriptor values for soils, vegetation, stream characteristics and surface geometry. The probability distributions may be referenced to such things as the concurrence of: (1) soil types and slope intervals, (2) stream order and bank heights and slopes, (3) vertical obstacle heights and spacing, (4) rainfall and soil moisture.

It is believed that regional unit environments are discernible and can be mapped. They correspond closely with the concept of "facets" proposed by the Military Engineering Experimental Establishment, Christchurch, England (MEXE).<sup>40</sup> They hypothesize that landscapes of similar lithologies with

histories of similar structural processes (faulting, folding, vulcanism, etc.) and erosional processes dictated by climatic influences will contain similar soil, topographic, vegetation and hydrologic patterns. The MEXE land system concept appears to be a logical framework within which the unit environment concept can be further developed using existing geologic soils, climatic and vegetation data bases. It is logical to believe that many unit environments are to be found within MEXE facets and in fact they may be synonymous in many cases. Cultural modifications of landscapes are not dealt with in facet designation but must be dealt with in unit environments, since many obstacles to vehicle movement, such as ditches, fence rows, bunds, etc., are man made.

The formidable task of identifying commonly occurring unit environments and establishing probability distributions for the various descriptors remains to be done. The problem may be attacked by exploiting relationships among such observables as soil moisture, topographic position, rainfall amounts, parent material, soil type, and slope class. The extensive effort required to establish joint distributions of environmental variables can be further alleviated by adroit use of statistical sampling methods.

Two illustrative approaches to utilizing the existing environmental data base to indirectly arrive at quantitative mobility intelligence pertaining to soft soil are given in Appendices D and E.

The first illustration, to be found in Appendix D, involves the analysis of long-term weather records to arrive at probable monthly excesses or deficiencies in rainfall and to relate these excesses or deficiencies to soil condition. This study for Southeast Asia (Singapore, Malaya, Thailand, Cambodia, Laos, North Vietnam, South Vietnam and part of Burma) was made from tabulated water-balance data obtained from 106 weather stations. A portion of the precipitation minus potential evapotranspiration data, specifically the data for the 30 weather stations in Vietnam, was factor analyzed to determine to what

extent the various stations exhibited common patterns of variation in time. Three basic terms or eigenvectors were isolated, and it was found that by weighting these eigenvectors appropriately at each of the stations, one could represent the field-collected data quite well.

This study concludes that the effects of seasonal variations in soil moisture are more far-reaching than their immediate manifestation in soil strength. In particular, a seasonal deficiency of moisture along with tropical temperatures has a profound effect on soil development. In the presence of dry heat, iron and aluminum oxides are formed by the process of laterization. These oxides congeal and make pebbles or even hard crusts on the surface. When oxidation of soil parent material takes place in the presence of water, both oxides and hydroxides are formed. Such a mixture rich in hydroxides is fine grained and does not congeal to make pebbles and crusts. This fact implies that a tropical soil developed under conditions of year-round rainfall would be less suitable for off-road movement than one developed under wet-dry conditions.

Current field operations in Vietnam and to a lesser extent in Thailand are furnishing to the military almost all of their experience in tropical off-road mobility. Without being aware of the continuously wet conditions in other parts of the tropics it would be easy for military and civilian R&D personnel to assume that "if it works in Southeast Asia it will work anywhere in the tropics". Such an assumption could prove disastrous in possible future operations, if off-road vehicles are designed for and tested only in Southeast Asia. There may be small areas in Southeast Asia where the upland soils do not undergo annual drought, but none of the 106 weather stations used in this study indicate it. A search should be made of already computed water-balance data<sup>41</sup> preparatory to making an inventory of continuously humid tropic areas. Such an inventory compared with past U.S. military operations and R&D testing in off-road mobility may show that U.S. experience in such areas is virtually nil. The mapping of continuously humid tropical areas would indicate where field exercises could be done under the unique conditions of continuously humid tropical climate.

The second illustration, given in Appendix E, demonstrates the possibility of applying soil moisture statistics derived from accessible locations in the world to analogous conditions existing elsewhere in the world. Use has been made of soil moisture content data collected by WES in Costa Rica and the United States. These data are used to describe the statistical occurrence of moisture levels in various soil types and topographic positions. The analyses of the data suggests that perhaps moisture level cumulative probability distributions can be established for various groups of soils, rainfall increments and topographic positions. When soil moisture content is expressed as percent of field capacity, many different soils tend to exhibit similar distributions. This fact makes moisture prediction less complicated than might have been expected. Further, it is indicated that WES has collected data from other countries such as Panama, Puerto Rico, Columbia and Thailand which can be used to develop the analog hypothesis still further. The ideal system envisioned is one in which moisture prediction and vehicle testing can be linked to the common denominator of soil moisture expressed as percent of field capacity. If we can predict moisture content for the soils in a remote terrain, and if we have determined the performance expectations of vehicles under analogous soil and moisture conditions, we can better plan and realize mission objectives in the remote terrain.

An approach to broadening the data base pertaining to stream characteristics is presented in Appendix F. An attempt is made there to describe the general characteristics of various stream types which are associated with particular terrains and landscape positions. These characteristics include bank slopes and bed and bank soil properties. The association of a characteristic range of stream bank heights with particular stream types is not clear. Bank heights of natural streams result from the balance between the erosive force of the channel flow and the resistance of the bed and bank material. A hydraulic model based on this process, developed in the appendix, relates the bank height to the erosive velocity and channel slope in the following manner:

$$Y = 0.020V^{3/2} S^{-3/4} \quad [1]$$

where Y = bank height (feet)  
V = erosive velocity (fps)  
S = water surface slope ~ channel slope

As shown in Appendix F, available empirical data on natural streams are in general agreement with this equation.

### 3.3.2. Environmental Basis of Off-Road Mobility Testing

The usual approach to vehicle evaluation by full-scale test is to test the vehicle against the Qualitative Materiel Requirement (QMR). Such testing determines whether or not the latest revision of the QMR is met, but does not necessarily determine performance in non-QMR environments nor allow comparison between vehicles in a common environment. Therefore, we have synthesized a systematic test structure which can be referenced to the many contrasting regional terrain complexes found in the world. The results of this synthesis are terrain negotiability tests which seek to evaluate the degree to which a vehicle can avoid or surmount environmental impedances it is likely to encounter in various regions of the world. We have not included other tests recognized as essential to complete evaluation of a vehicle such as service tests, reliability, safety and maintenance. Terrain negotiability tests seek to evaluate the degree to which a vehicle can avoid or surmount environmental impedances it is likely to encounter in the world environment. The work was aimed at structuring tests rather than at developing measures of performance. The details of developing the taxonomy are contained in a paper presented at the Off-Road Mobility Research Symposium, Washington, D.C., June 1968 . The salient features of the paper are discussed here.

The basic proposal is to structure negotiability tests in order to define the vehicle performance envelope so that, given an appropriate environment description of any area, the degree of compatibility between the vehicle and terrain can be assessed. The method of approach involves two basic steps. The first is the formulation of a finite number of test environmental categories arranged in order of increasing complexity, where "complexity" refers to the number of environmental factors (such as soil, slope, and vegetation) acting in concert. The second step is the specification of a scale of environmental severity within each test environment category, where "severity" refers to the level of difficulty presented by a particular factor. For test purposes, the range of severity must be based on the corresponding range of severity met in nature. Subdivision of this range into levels or intervals of severity is often necessary in order to define specific tests to which a particular vehicle is to be subjected. This stratification must be based on the sensitivity of the vehicle response to the particular environmental factor under consideration.

To be meaningful, test results must be assessed for degree of compatibility of the vehicle with the terrain based on a comprehensive world environmental concept. Work performed under Project MERS by WES,<sup>42</sup> the Project MERS Terrain Factor Family Maps,<sup>39</sup> and the work of Nuttall, Grenke and Smith,<sup>5</sup> on "GO NO-GO" terrain classification all involved delineating irregularly shaped -- but adjoining -- areas of land on the basis of environmental factors related to mobility. In the Terrain Factor Family Maps, for example, observations were made on the terrain for each of the "terrain factors", such as soil strength, terrain slope, obstacle dimensions, vegetation spacing and diameter, and hydrologic features. These observations were compiled from aerial photographs supplemented by actual field measurement. A map was then prepared for each factor by grouping the measurements for the factor into classes and marking off and identifying areas on the map where measurements fell into the same class. Thus the map for each factor

was "carved up" into disjoint but abutting areas of irregular shape -- depending upon where adjoining similar measurements occurred -- that gave the maps the appearance of abutting flagstones. By overlaying these individual maps one on top of the other, one can obtain an "intersection" of the measured factors which results in a map of the joint occurrence of all the factors mapped in "flagstone" style. WES used an analogous approach when it used the individual maps as a basis for calculating average speed for a given vehicle over this terrain and produced their own map where the "flagstones" represented areas of the same average speed rather than areas of common joint occurrence of environmental factors. Nuttall, Grenke, and Smith's "flagstones" represented areas of "GO" and "NO-GO". This "abutting flagstone" delineation of regional areas suggests that the world environment can be regarded as being composed of a finite number of disjoint "unit environments", each of which would consist of a value or interval of values for each environmental descriptor considered relevant to mobility.

A particular set of such values (or a unit environment) can occur at various locations on the earth's surface, and the several locations of the same set can be considered analogs of each other. Any regional environment can then be represented as a union of appropriate "unit environments". Testing against a tractable number of the different unit environment analogs representing environments most frequently encountered in the world environment would define the vehicle performance envelope and provide a basis for regional or world-wide performance prediction. Tests would be performed according to a schedule of increasing difficulty, which would render unnecessary any testing beyond the order of complexity and severity at which the vehicle failed requirements or was immobilized. It is obvious that any attempt to synthesize all possible combinations of levels of factors to identify and list the complete spectrum of unit environments, even though feasible on a computer, would lead to an impractical number of environments. Testing on all of these would be

prohibitive from a cost and time standpoint, even if it were actually possible to do so. To arrive at a tractable number of basic unit environments one should use those combinations of severity of factors that occur frequently in nature and are also distinguishable by the vehicle. Rare combinations should be used only as necessary and tested on an ad hoc basis.

Regional prediction of environmental performance would be based on comparison of the vehicle performance envelope developed from testing with combinations of factors and ranges of descriptor values in the region. To be applicable, the unit environments of the area must be commensurate with those tested upon, and rare unit environments must be appropriately described to permit the preparation of valid ad hoc tests as required. The degree of refinement of the assessment made of any region will depend upon the degree of detail in the regional survey. Therefore, implementation of the theory outlined requires more detailed knowledge of the relative frequency of occurrence of unit environments in nature in order to determine the trade-off between "standard" and ad hoc types of tests.

### 3.3.3 Mobility Testing on Natural Soils

A comprehensive attempt to develop unit test environments must encompass all major impedance to mobility: soil characteristics, terrain geometry, vegetation, hydrological factors and cultural features. Initial attention was devoted, however, to a consideration of soils as related to vehicle testing.

There are several ways in which soil can affect a vehicle to produce poor mobility or immobilization. The soil can provide insufficient traction or insufficient bearing strength, or it can impede motion by adhering to the running gear. Each of these soil characteristics is

influenced by soil moisture content in a manner which varies with soil types, as is illustrated by Figure 13 . Other soil properties of importance are texture (particle size distribution), soil layering, and the structural arrangement of the soil particles.

It is well known that soil texture influences the strength characteristics of soils directly. Of great importance also is the influence of contrasting textural layers in the distribution of moisture in a soil column. When soil layers with contrasting textures are in contact, movement of water from the upper to the lower layer is slowed considerably. Impervious silt or clay pans associated with plates or massive soil structure, impede downward movement of water also. Apparently changes in texture of the underlying material results in permeability differences which prevent downward movement. The implication to vehicle traction is obvious. If the contrasting layer occurs near enough to the surface so that increased thrust is not negated by increased motion resistance, greater traction will result by having the wheel or tracks move through the lower layer. The importance of soil layering has been discussed by Bekker in connection with implications for vehicle design.<sup>16</sup> Bekker recognizes that contrasting layers do exist in natural soils and notes that in many cases it is more realistic to view soil as a stratified media consisting of a very soft plastic layer resting on a hardpan rather than as a semi-infinite homogeneous continuum.

Soil structure is defined as the aggregate arrangement of the soil particles. They may be arranged in a blocky fashion, as plates, as single grains, or as a mass held together by a weak or strong cementing agent. Soil structure is a result of soil-forming processes acting through time. The structure of recently transported material is quite different from that of a soil developed in place. Two soils may have the same texture, plasticity and even moisture content but may differ in strength due to structural differences alone. The more common influence of structure is its effect on the distribution of moisture in the soil

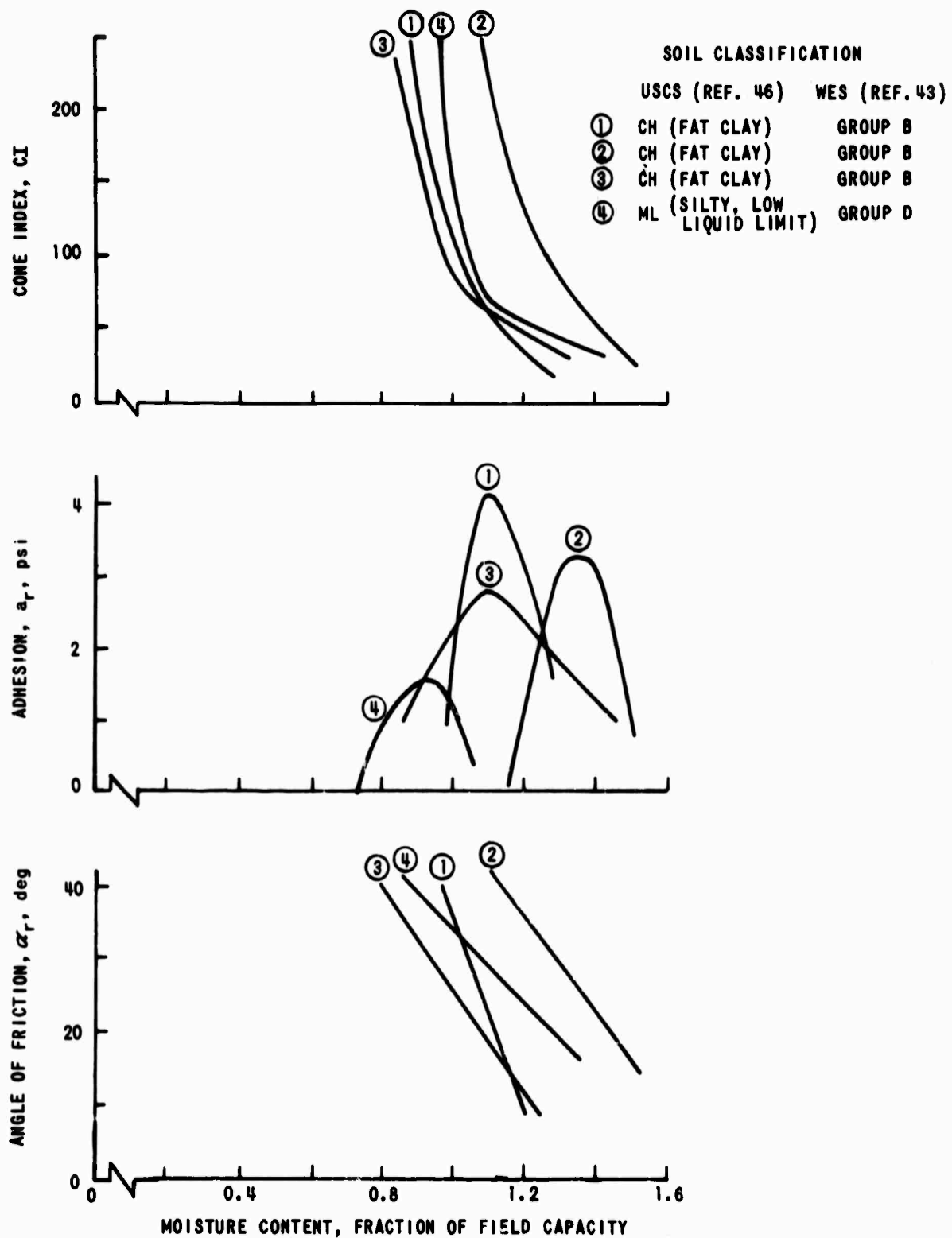

Figure 13 TYPICAL CONE INDEX, ADHESION AND ANGLE OF INTERNAL FRICTION CURVES

profile. One reason that soil structure has not been seriously considered is that suitable quantitative procedures for determining and describing it have not been available.

Two approaches to mobility testing on natural soils become evident. One considers such measurable soil parameters as cone index (CI), adhesion ( $a_r$ ), and angle of friction ( $\alpha_r$ ) in conjunction with soil moisture and suitable soil groupings such as Unified Soil Classification System (USCS) soil types. The other employs elements of pedological soil classification to integrate mineralogic, structural, and layering phenomena into a testing program. There is a substantial world-wide areal inventory of soil properties within pedologic soil classification systems, but inventories of areal distributions of engineering values, such as cohesion and angle of internal friction are severely limited.

The curves of Figure 13 indicate the possibility of developing a minimum number of universal curves relating bearing strength, adhesion, and angle of friction to moisture content. Since curves for many soils are very similar in shape, it should be possible to choose a very few representative soils to be used for vehicle testing. Then, the performance of a vehicle determined on the test soil would have the same kind of moisture content dependence as on other natural soils of the same representative class, even though the actual values of moisture content might be different among soils within the class. Waterways Experiment Station has suggested that natural soils can be aggregated, for mobility purposes, into four groupings displaying different strength characteristics.<sup>43</sup>

Table 1 is presented as a key for digesting pedologic soil survey information into a framework which can be used to agglomerate the many pedologic soil types into groups which ostensibly present distinctly different challenges to off-road movement. Most natural soils can be placed into one of the categories. Consideration of contrasting layers in the soil profile either in texture, structure or both is an important



feature of this key. Another feature is the inclusion of parent material criteria (i.e., characteristics of geologic material from which soil developed).

There are two major methods of material formation: "sedentary", where the soil is formed in situ, and "transported", where the particles forming the soil have been transported to the site by glaciers, water or wind. If the soil has been developed in place from rock, the type of rock must ultimately influence the mineralogy and structural characteristics of the resultant soil. Especially important is the resultant clay mineralogy. As an example, montmorillonite type clay normally results from the chemical alteration of basalt, whereas kaolinite clay almost always results from extreme chemical alteration of granite.

The relationship between parent material and mineralogy of soils developed from transported materials is not as clear. There is much more mixing of various minerals in transported materials. It is likely that there are significant differences in structural and compaction characteristics of similarly textured soils developed in parent materials transported by different processes. The dense compact nature of glacial till as opposed to loose friable outwash is an example. The listing of parent materials is not all-inclusive but does include those which occur on a great portion of the earth's surface. In fact, sedimentary rocks underlie about 3/4 of the earth's land area.

The units which can be categorized into Table 1 will generally correspond to soil series in the pedologic system. According to definition, each soil in a soil series is developed from parent material of similar character. Variations in the textures of the surface horizons do occur in soil series, but there is not apt to be much variation. The arrangement and texture of underlying horizons of soils belonging to the same soil series are within narrowly defined limits.

Perhaps the criteria for differentiation presented in Table 1 are not all necessary. For instance, the vehicle may not respond differently to a fine textured soil derived from shale as opposed to one derived from limestone. Nevertheless, the distinctions should be made unless shown to be of little consequence. There is a firm basis, however, for the texture differentiations. The  $\alpha$ ,  $\beta$ ,  $\gamma$ ,  $\delta$  groups in Table 1 correspond closely with the A,B,C,D groupings proposed by WES.<sup>43</sup> We have chosen here to include organic soils in a separate group, since their properties are quite different from mineral soils. This separation will also better facilitate correlation with pedologic soil surveys.

It is evident that soils representative of Group  $\alpha$  occur only on a small portion of the earth's surface (sand dunes, beaches, some glacial outwash deposits). Soils of  $\beta$ ,  $\gamma$ , or  $\delta$  surface texture with pure sand within 20 inches probably occur even less frequently, except under organic surface horizons, the reason being that except for very young soils there has been enough eluviation of clay into the lower horizon to preclude the occurrence of a horizon containing nearly pure sand-size particles. Therefore, texture  $\alpha$  is not listed as a contrasting layer in Table 1 except in combination with organic surface horizons (Group  $\epsilon$ ).

In Table 1 combinations which commonly occur on a world-wide basis are marked with an X. Combinations which rarely if ever occur are marked with a dashed line. As an example, the block marked with an asterisk is the concurrence of a medium-textured surface soil derived from shale and a contrasting fine textured layer within 20 inches of the surface.

It is obvious that the large number of combinations makes it impractical to systematically field test vehicles for all of them. A suggested approach to a basic test matrix is presented in Table 2. In this matrix the occurrence of contrasting layers within 20 inches is not considered. Testing on soils with contrasting layers within 20 inches would be done on

Table 2  
BASIC TEST MATRIX

SOURCE OF SOIL PARENT MATERIAL		SOIL PARENT MATERIAL	TEXTURE <sup>*</sup> (PARTICLE SIZE DISTRIBUTION)			
			COARSE (SAND) $\alpha$	FINE $\beta$	MODERATELY FINE $\gamma$	MEDIUM $\delta$
SEDENTARY	SEDIMENTARY	SANDSTONE	✓	•	•	✓
		SHALE	•	✓	✓	✓
		LIMESTONE	•	✓	✓	✓
	IGNEOUS	GRANITE	✓	•	•	✓
		RHYOLITE	✓	✓	✓	✓
		DIORITE	•	✓	✓	✓
		SERPENTINE	•	✓	✓	✓
		BASALT	•	✓	✓	✓
	METAMORPHIC	GNEISS	✓	✓	✓	✓
		SCHIST	•	✓	✓	✓
		QUARTZITE	✓	•	•	✓
		SLATE	•	✓	✓	✓
		MARBLE	•	✓	✓	✓
	TRANSPORTED	GLACIAL DEPOSITS	GLACIAL TILL	✓	✓	✓
		GLACIAL OUTWASH	✓	•	•	✓
WATER DEPOSITS		ALLUVIUM	✓	✓	✓	✓
		MARINE DEPOSITS	✓	✓	✓	✓
		LACUSTRINE	✓	✓	✓	✓
WIND DEPOSITS		LOESS	•	•	✓	✓
	SAND DUNES	✓	•	•	•	

\* TEXTURE  $\epsilon$  (ORGANIC) IS A SEPARATE CLASS  
CONSISTING OF VEGETATIONAL RESIDUE -  
FREQUENTLY OCCURS ON EARTH'S SURFACE

✓ - OCCURS ON SIGNIFICANT PORTION OF  
EARTH SURFACE

• - OCCURS RARELY OR NEVER

ad hoc basis referenced to particular regions of the world where off-road mobility capabilities and predictions are urgently needed (e.g. Vietnam). Soil survey reports for those regions would indicate the predominant layering conditions for which special testing would be done. Only the more developed countries will have soils data which can fully satisfy the scheme presented in Table without supplementary study.

The results of testing on various natural soils could eventually take the form of functional relationships between, for example, moisture content and soil properties such as texture and parent material as independent variables and speed as the dependent variable. The stipulation of moisture content as percent of field capacity would serve to normalize the expression of moisture contents in soils with varying moisture holding capacities, and may tie in with a soil moisture predictive system.

Past experience has shown that vehicle movement is not seriously impaired until the soil is at about 100 percent of field capacity.<sup>44</sup> Data analysis in Appendix F indicates that soils are rarely wetter than about 150 percent of field capacity unless inundated. Therefore, testing on soils with moisture contents between 75 percent and 150 percent of field capacity would cover all but rarely occurring levels in the wetter range.

The differential influences of soil properties resulting from parent material and textural differences must be evaluated in conjunction with moisture expressed as percent field capacity, on vehicle performance. The following sequential type approach is suggested, based on the subdivisions of Table 2.

Since texture  $\epsilon$  (organic) consists of vegetational residue which is from an entirely separate regime than the other soil textures, it is proposed that this category of soil be designated a priori as one type of soil to be employed in vehicle testing.

Texture  $\alpha$  (coarse) is designated as sand and is known to behave generally in an inverse manner relative to the other three textures in the presence of moisture. Therefore, it is proposed to designate it also as an a priori type of soil to be employed in vehicle testing. If differences in types of sand assume large proportions in a particular instance, investigation might profitably be undertaken on the basis of the different parent materials shown in the chart.

It is proposed that the sedentary parent materials be investigated for their relative effect on mobility by means of a screening type of designed experiment or a series of sequentially designed experiments. An initial design might consist of a 6x3x2 factorial experiment with two replications that would involve 72 test runs. This would consist of six parent materials (two from each of the three "Rock Forming Processes"), the three textures, ( $\beta$ ,  $\gamma$ , and  $\delta$ ), and two levels of moisture expressed as percent field capacity. The analysis of the results of such an experiment would:

1. Reveal whether or not different parent materials significantly affect soil influence on mobility and if so, the degree of such effect.
2. Indicate the relative magnitudes of the effects of texture and soil moisture content as they affect mobility.
3. Assess the significance and relative magnitude of the interactions between: 1) parent materials and texture; 2) parent materials and moisture; 3) texture and moisture; 4) parent materials, texture and moisture.
4. Estimate the magnitude of the "test error" in an absolute sense as well as relative to the variation contributed by the above effects which proved to be significant.

5. Establish whether or not there is a significant variation among the three rock forming processes within which the parent materials are nested.
6. Determine whether or not further experiments should be conducted on the other seven parent materials.

If parent materials were found to be significant, this experiment and further work could result in a "mobility taxonomy" or mobility grouping of the parent materials which would reduce the number of mobility-different soils required for routine testing. Since the transported soils are mixtures of the sedentary soils, it is proposed to treat the transported soils last in the sequential investigation, taking advantage of what is learned up to that point. It may be that they would have to be treated through ad hoc testing on the basis of the composition in the specific area of interest.

#### 3.3.4 Data Output

Even though data may be completely and accurately acquired and comprehensively analyzed, the output must be communicated to the ultimate user in a fashion that is immediately usable and is as unambiguous as possible in interpretation by him. Time spent by the user in acquiring and analyzing data before he can use it prevents him from applying it with optimum speed and effectiveness. Since there are many users with different missions to perform that rely on the same basic data, it is essential that rapid and flexible means be available to provide specialized presentations of completely analyzed data. The modern computer and allied equipment provide such a means of analysis and presentation.

One user requiring detailed presentation of analyzed data is the vehicle commander. Easily interpretable information can be presented to him in the form of a map. The map may contain environmental information



MAP SYMBOL  
 \*     RCI  
 |     25-60  
 /     60-100  
 \     60-100  
 /     100

\*OCCURS ONLY AT MAXIMUM DISTURE CONDITION WHICH HAS < 30% PROBABILITY OF OCCURENCE

Figure 14 SURFACE COMPOSITION "RCI" FACTOR

such as the locations of steep slopes, thick forests, etc., or it can contain actual performance information for a particular vehicle.

Persons such as theater commanders, vehicle allocators, and perhaps vehicle designers require less locational information than vehicle commanders, but can make efficient use of statistical information and, in some cases, relatively small-scale maps. Statistical information could contain such data as percentage of area with slopes over 50%, percentage of area impassable to a particular vehicle, etc.

The obvious application of computers to this kind of data processing was demonstrated by analyzing one of the MERS areas of Thailand. The area selected was from the Kohn Kaen region and was described on four maps; surface geometry, surface composition, vegetation, and hydrologic geometry. Each of these four maps was digitized on a 100 meter grid producing four numbers for each of 39,000 squares 100 x 100 meters in size. The surface geometry, surface composition, and vegetation maps were intersected by joining each of the three numbers end-to-end to produce one number for each 100 x 100 meter square. The 39,100 numbers thus produced were stored on magnetic tape. Two other tapes were similarly created from surface composition and high water hydrology, and from surface composition and low water hydrology.

These three maps form the environmental basis for production of various forms of output information. Any individual environmental parameter or any combination of two or more can be recovered and a map printed with the standard computer line printer. An example of this kind of map showing Rating Cone Index (RCI) is given in Figure 14. The advantage of producing such a map by computer rather than traditional techniques is that it can be rapidly updated by simply changing the appropriate input tape. Also, a computer can rapidly perform statistical computations and print results along with the map.

A second kind of map can be produced by comparing these environmental characteristics with parameters of a particular vehicle. Such comparisons were made through a subcontract with WNRE, Inc.<sup>38</sup> The results of the terrain-vehicle comparisons were graphically displayed in computer generated maps which indicated areas of Go/No-Go. Areas of "Go" were left blank and areas of "No-Go" were identified by letter symbols indicating the most probable reason for immobilization. An example of such a map for an M113 Armored Personnel Carrier is shown in Figure 15. Further explanations and examples of this type of map appear in Reference 38.

A map giving the distance in a particular direction to a No-Go point can be derived from the above type of map. An example of such a map is given in Figure 16. Statistics derived from a series of similar maps can yield directional characteristics of a given area for a given vehicle. An example of a map that can be obtained using these statistics, e.g., one giving the minimum distance to No-Go in one of eight compass directions, is shown in Figure 17.

All of the maps referred to so far have been produced by a standard IBM line printer. Such maps are distorted, since five horizontal characters require the same space as 3 vertical characters. A reasonably easy device to use is a Xerox LDX plotter, which produces a standard Xerox copy from a cathode ray tube with discrete beam locations addressable in two coordinates. Maps produced by an LDX plotter have the advantage of convenient size and freedom from distortion, and appear with the usual types of symbols one expects to see on a map, as shown in Figure 18.

Other devices, such as a flying spot scanner, have been used to present data as maps. The scanner produces a photograph about 3 x 5 inches in size. The symbols used on the map are the usual type of texture patterns and/or grey level variations.

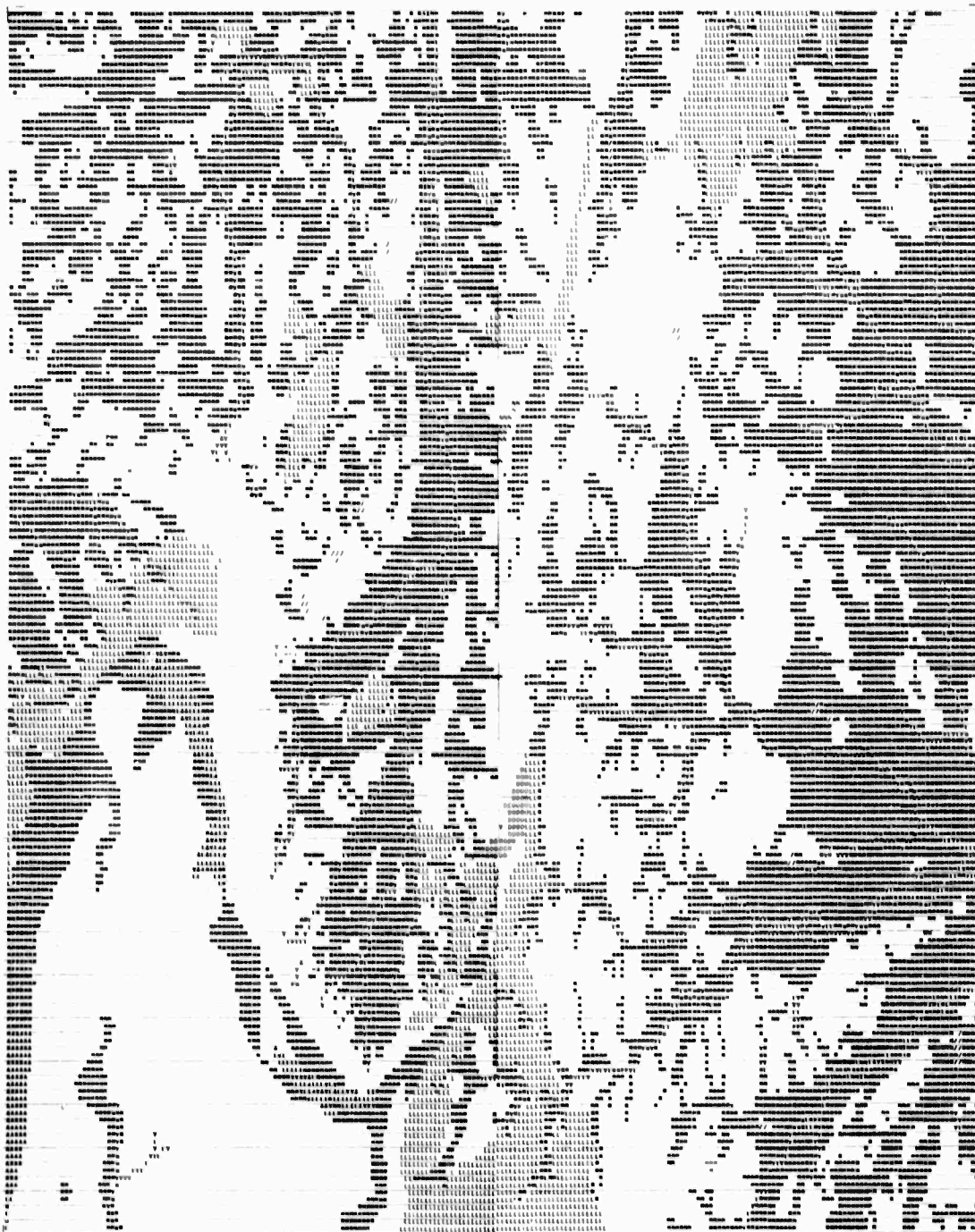

Figure 15 DIAGNOSTIC GO/NO-GO MAP FOR M113 APC - AREAL FEATURES ONLY



NUMBERS SHOW DISTANCES TO "NO GO" IN THOUSANDS OF METERS IN A NORTHERLY DIRECTION  
 N-DISTANCE TO "NO GO" IS BEYOND NORTHERN BOUNDARY OF MAP  
 \$-DISTANCE TO "NO GO" IS BEYOND 8,000 METERS IN A NORTHERLY DIRECTION

Figure 16 DIRECTIONAL COMPUTER MAP "NORTH" DISTANCE TO "NO-GO"-WEASEL

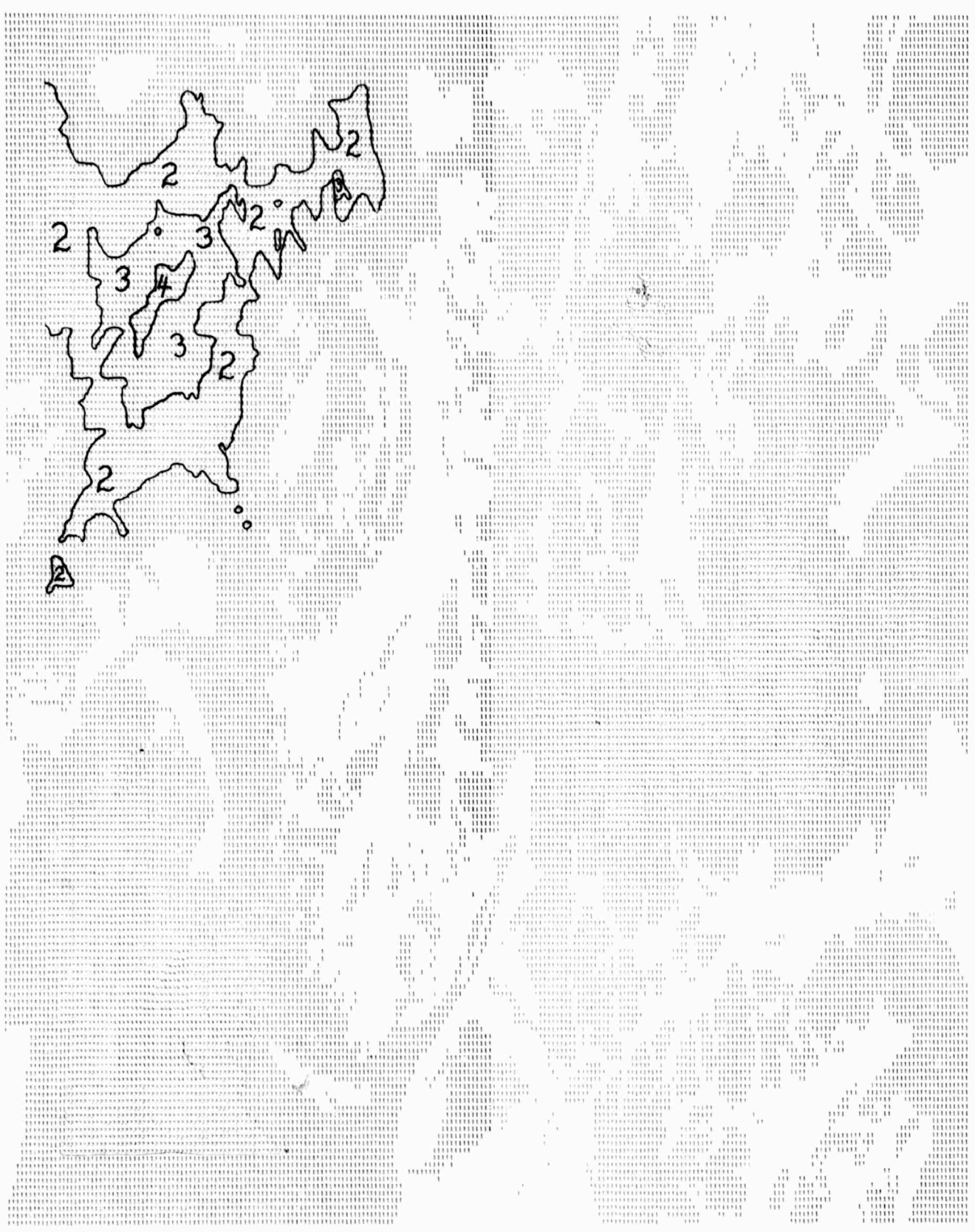
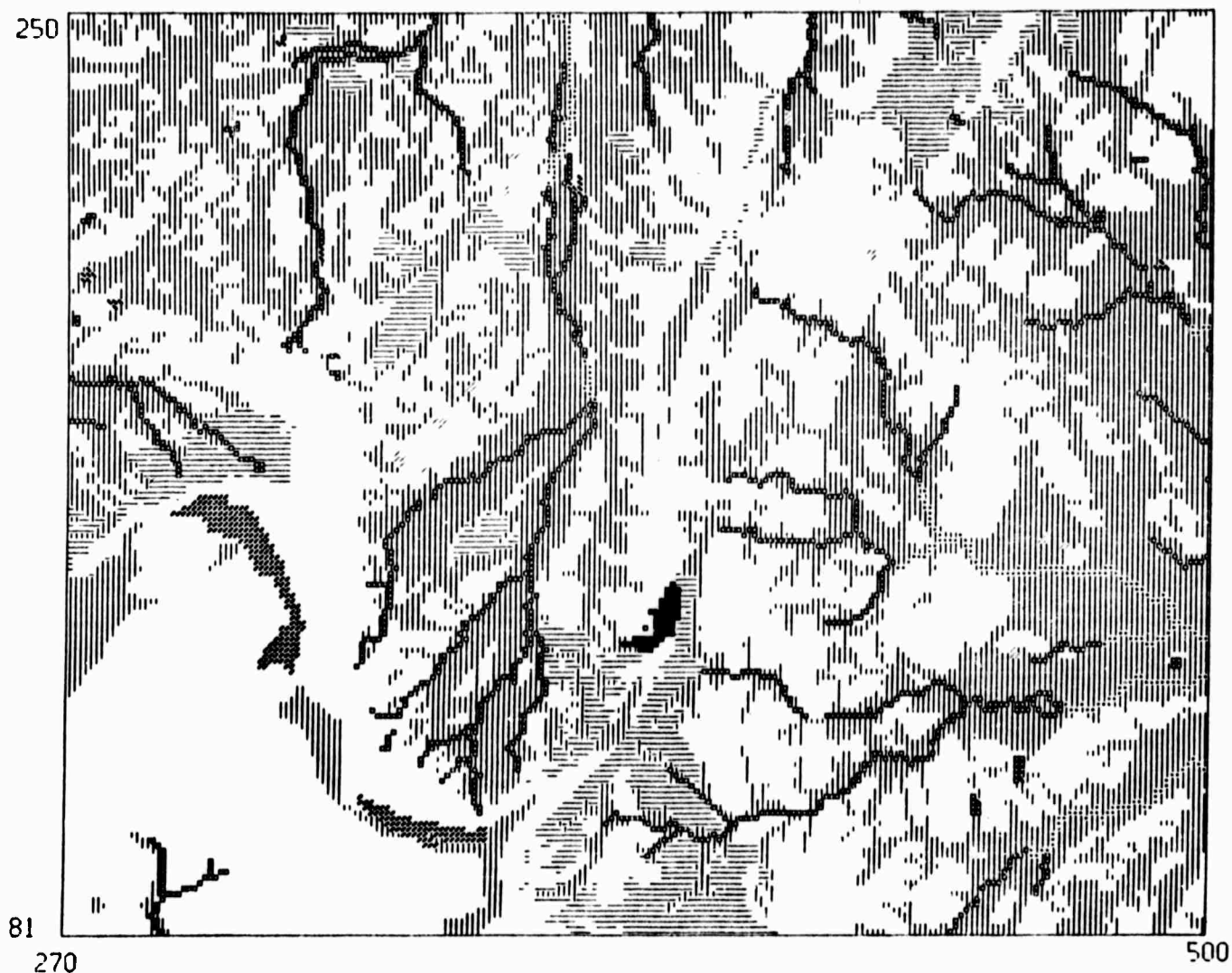

Figure 17 OMNI-DIRECTIONAL COMPUTER MAP MINIMUM DISTANCE TO "NO GO"-WEASEL



TEST	FAILURE MODE
○	GO REGION
⌋	UPPER BANK GEOMETRIC INTERFERENCE
	NON-VERTICAL OBSTACLES VS NET TRACTION
====	OVERRIDE FORCE FOR SMALLER TREES VS NET TRACTION
■	SPACING OF SMALLER TREES VS BASIC OVERRIDE
✦	BELLIES ON BANK LIP
▨	SLOPES AND SOILS VS VEHICLE TRACTION
.....	WATER TOO DEEP FOR FORDING

Figure 18 MOBILITY MAP PRODUCED BY LDX PLOTTER FOR THE 5 TON GOER VEHICLE

Although all of the figures included in this section are for the MERS type of input, the same forms of output (maps and statistics) can be produced with any kind of quantifiable environmental data. The use of a computer permits treatment of a large number of points, the use of various outputs, and rapid updating of input data. A separate technical report<sup>45</sup> presents advances made by Cornell Aeronautical Laboratory in computer storage, processing, retrieval, analysis and presentation of environmental information.

The feasibility and value of employing computer technology to generate a variety of mobility maps and statistics to satisfy the needs of different users is, of course, dependent on the quality and completeness of data acquisition and analysis. A thorough inventory of the joint occurrence of terrain descriptors is in itself not enough to generate mobility maps and statistics. The responses of vehicles to the spectrums of interacting terrain impediments delimited in the unit environments must be evaluated either by field or model testing.

We believe that the "unit environment" approach previously discussed is a means by which data acquisition and vehicle mobility testing can be efficiently coordinated to provide the necessary quantitative inputs from which mobility statistics and catographic displays can be produced by computer methods.

An integrated approach to data acquisition, analysis, and presentation would be of benefit to many sectors of the off-road mobility community. The magnitudes of the various descriptors within commonly occurring and/or especially significant unit environments will provide vehicle designers with realistic design guidelines. They will better be able to evaluate the effectiveness of design modifications relative to the complete environmental scene. It may be, for instance, that a modification to increase obstacle override ability is not needed in many unit environments or is sacrificing needed tractive ability in others.

Unit environments can be of great utility in describing the scenario for military test compliance courses. If the vehicle is to be designed to operate in Central America, as an example, the scenario would include unit environments common to that region.

For many regions of the world, existing terrain and climatic intelligence impart reasonable bases for the allocation of specific vehicle types. For mission planning at the tactical level of operation, the situation is less satisfactorily resolved. The integrated approach to data acquisition, analysis, and presentation proposed in this report is a beginning towards satisfying the needs for reliable mission-oriented interpretations of remote terrains.



### 3.4 SOIL MECHANICS

Prediction of tractive and resistive forces developed at the running gear - soil interface of a vehicle depends on knowledge of the dynamic flow field in the soil, the partitioning of the energies dissipated in the soil and the interface, and the distribution of the forces at the interface. Although existing vehicle performance prediction equations and soil measurement devices stem from theories concerning soil behavior under load, the measurements made to assess the validity of the equations have invariably been made external to the soil. Thus, the underlying theory has not been tested, and is a source of prediction uncertainties.

In the Second Semiannual Technical Report<sup>4</sup> we outlined our plans for obtaining data on observable phenomena in the interior of a dynamically loaded soil mass and for using these data in establishing generally valid constitutive relations for these soils. These plans centered on the visio-plasticity method as the most promising approach to studying the mechanics of soil under dynamic load, supported by studies of the microscopic behavior of soil under such conditions. Continued effort on alternate methods was also recommended. Progress toward these goals, through efforts made by CAL and by CAL subcontractors, is reported in the following pages.

#### 3.4.1 Visioplasticity Method

A major effort has been placed on determining the feasibility of using the visio-plasticity method to analyze typical off-road mobility problems as they arise from soft soils. The visio-plasticity method assumes that the velocity field within the worked material can be determined experimentally, and that the stresses can be obtained analytically from these measurements. That is, the strains and strain rates are calculated directly from the velocity field while the stress distribution results from an analytical solution of the equilibrium (or motion) equations and the constitutive

equation relating the stress and strain for the material. The basic requirements for applying viscoplasticity techniques to soft soil mobility and the methods success in metal processing analysis were previously summarized.<sup>4</sup>

The efforts to determine the feasibility of this approach were a joint venture between CAL and McGill University. Under ORMR subcontract, McGill University conducted a number of tests specifically for the purpose of providing data for analysis at CAL. These efforts, reported by CAL<sup>47</sup> and McGill University,<sup>48</sup> provide the basis for the following discussion.

The research at McGill University involved soil bin experiments to determine the flow field existing in the soil beneath a vertically loaded, powered slipping wheel. The recorded movement of lead markers in the soil as obtained by X-ray photography during passage of the wheel was a primary source of data.

To prepare moist soil, a dry kaolinite was placed in a container in alternating layers with a prescribed amount of water (approximately 50 percent by weight) and allowed to rest until the water migration was equilibrated. The soil test bed, with lead markers located in the wheel midplane, is then built up from this material in layers through a process of remolding small quantities and tamping them into position. It should be noted that the soil is built up so that the plane of the markers is horizontal. The lead markers are embedded when the layering is one-half the required depth. When the test-bed preparation is completed, the bed is rotated so that the marker plane is vertical and in the midplane of the wheel. Walls are maintained along the sides of the soil so as to prevent any side flow.

Typical of soil remolding processes, it is difficult to control the soil mechanical properties. This was confirmed by a series of triaxial tests on the remolded soil, where some dispersion in stress-strain data was evident. The subsequent analysis used an average stress-strain curve obtained

from these triaxial data, but it is apparent that a more reliable soil preparation method is needed.

A carriage traveling at a constant velocity carried a rigid, 13.5-inch-diameter wheel having a width of 3.75 inches equal to that of the soil test bed. In addition to the linear velocity, an angular velocity was imposed on the wheel. Transducers located on both the carriage yoke and the wheel-axle shaft measured the drawbar pull and torque acting on the wheel. Sinkage was determined by measuring the relative distance between the wheel center and side rails.

Before, during, and after a test run, X-ray photographs were taken for a 6- by 7-inch area (in the marker plane). Three X-rays were shot during the test with each shot separated by the time required for the wheel to traverse six inches. Thus, in a coordinate system moving with the wheel, these three X-ray shots map out the soil displacements over an area approximately 18 by 7 inches (steady-state motion has been assumed). In this system, the X-ray measurements are equivalent to the displacement time history for the soil motions. Difficulty was encountered in matching the data from one shot to the next. This difficulty could be eliminated by having a system where the entire flow region could be instantaneously photographed.

Consistent with the steady-state assumption, marker positions in a horizontal row relative to a coordinate system attached to the wheel were taken as either a streamline or a pathline for a material particle. Movement along a row from wheel front to back is equivalent to following the motion or time history of a particle. Since the time increments between markers may be determined from the distance between these markers in the initial or undeformed configuration and the wheel-axle velocity, the relative time history for any marker is known. Consequently, first differences of marker positions are proportional to soil velocities.

Because uniform strain conditions are assumed throughout the soil thickness, the nonzero strain-rate components are determined directly from the velocity field. Furthermore, the strain-rate components are used to define an equivalent strain rate and an equivalent strain which permits the soil mechanical properties to be incorporated into the analysis using a triaxial stress-strain curve.

This investigation assumes the material behaves as a work-hardening Levy-Mises solid.\* Such representation is perhaps reasonable for the nearly saturated clays used in the study. However, it is apparent that rate effects are important and a viscoplastic relation may be more appropriate and could readily be incorporated into this method of analysis.

Once the kinematic variables are determined experimentally and the soil mechanical properties known, the viscoplasticity theory may be used to determine the loads (forces and stresses) acting on the wheel. Consideration was given to both the determination of the energy dissipation rate within the soil medium and to the stresses acting in the soil-wheel interface.

The energy dissipation rates in the soil medium,  $\dot{E}_i$ , and that due to the velocity jump along the soil-wheel interface,  $\dot{E}_s$ , for three tests with different slips are listed in Table 3 and shown graphically in Figure 19. These points are labelled viscoplasticity method while those calculated from the external measurements of loads and velocities on the wheel are labelled experimental points. Significantly, the results indicate that energy is dissipated in two ways because of the stress and strain-rate fields in the soil medium and as a result of a velocity discontinuity between the soil and the wheel surface.

---

\* A rigid plastic solid where the yield condition is assumed to depend only on the second invariant of the stress deviator tensor.

**Table 3**  
**COMPARISON OF MEASURED AND CALCULATED ENERGY DISSIPATION RATES**

SLIP PERCENT	LINEAR VELOCITY in./sec	ENERGY DISSIPATION RATE in.-lb/sec			
		MEASURED		CALCULATED	
		$\dot{E}_m$	$\dot{E}_i$	$\dot{E}_s$	$\dot{E}$
3	3.1	65	49	5	54
19	3.2	80	54	15	69
48	4.1	148	75	86	161

m - MEASURED EXPERIMENTAL INPUTS  
 i - INTERNAL ENERGY DISSIPATION  
 s - SURFACE ENERGY DISSIPATION

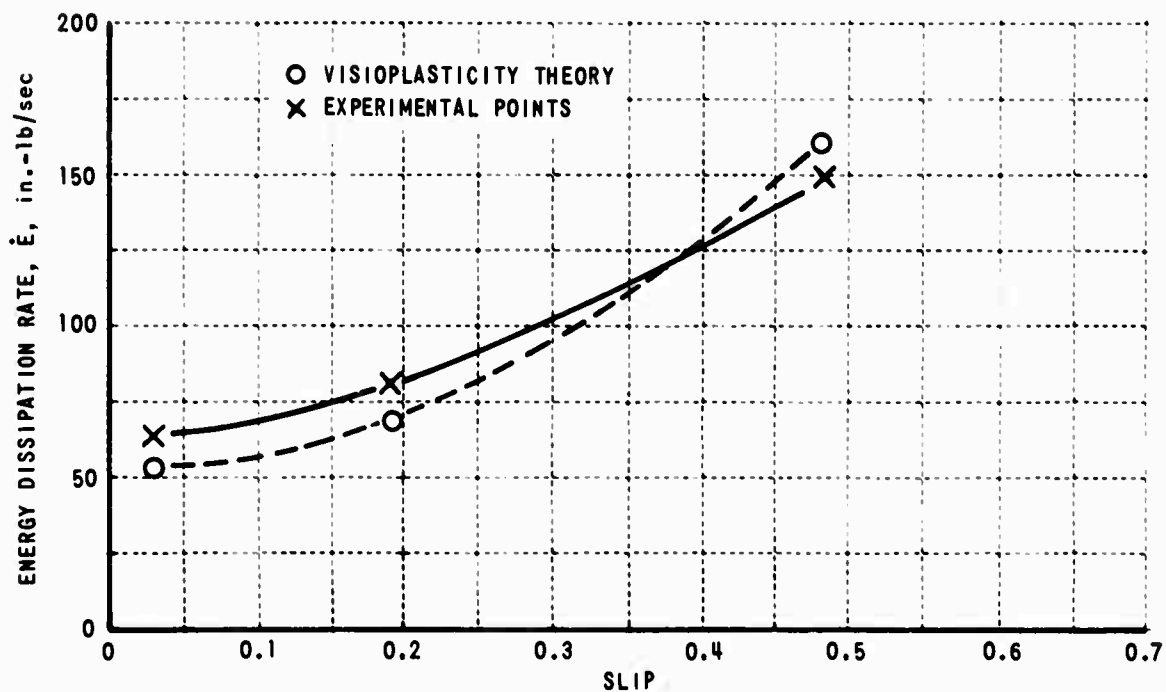

Figure 19 ENERGY DISSIPATION RATE SHOWN AS A FUNCTION OF SLIP

Using the viscoplasticity method, equations relating the measured variables to the stresses in the soil-wheel interface were developed. The interfacial radial and shear stresses calculated by this method for a wheel having three percent slip are shown in Figure 20.

Some comments concerning the calculated stress distribution are in order. The radial stress appears to reach a maximum value near the point where the soil enters the interface. This is in contradiction to the plate-sinkage models where the maximum radial stress is obtained at the point of maximum sinkage. The shear stress takes on its maximum value near the bottom of the wheel. As the soil enters the interface region, this maximum is reached gradually; but, once reached, it tends to remain constant.

The present results indicate that the viscoplasticity method can be used to determine either the energy dissipation rate or the stresses within the soil medium. However, some improvement in both the soil preparation process and the measurement technique is necessary. These problems have been considered and, based on the results of the Cornell University study (see Section 3.4.2), various ways of preparing a suitable soil medium appear feasible. The problem of measurement (namely, the instantaneous visualization of the flow field) may be solved with commercially available pulse X-ray equipment, supplemented by photographing surface grids through glass walls (see Section 3.4.4).

The viscoplasticity method should be extended to other more important problems. We cite here two categories: (a) so-called running gear elements and (b) soil measuring instruments. Wheels, tracks, grousers, etc., are included in the former, while indentors and soil surface measuring devices make up the latter. If the kinematics of each problem can be adequately determined and the soil properties specified, then the viscoplasticity method could serve as a powerful tool for relating the soil behavior and its mechanical properties to the external loads.

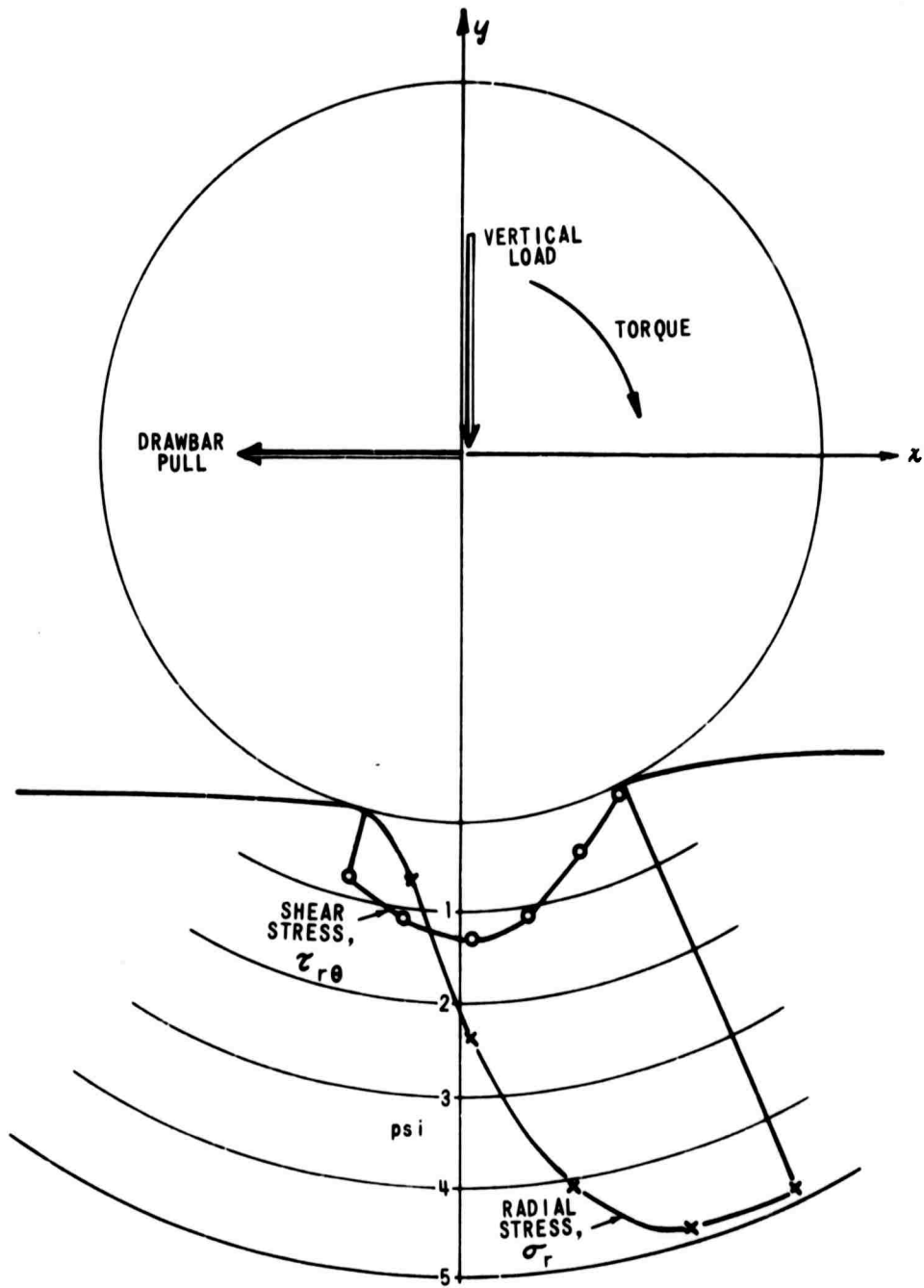

Figure 20 STRESS DISTRIBUTION CALCULATED FOR RIGID WHEEL HAVING THREE-PERCENT SLIP

The results of these kinds of visioelasticity analyses should serve as a basis for both the verification of current and the formulation of new engineering models describing the soil-vehicle interaction process. That is, these models rely on assumptions which can now be checked by these more intensive investigations.

Knowledge of how forces are developed, as provided by the visioelasticity type of analysis, could also greatly influence current thinking concerning off-road locomotion. For example, the partitioning of the energy dissipation rate, as indicated above, implies that for scale modelling the energy dissipation densities should be similar between model and prototype. It can readily be shown that this requires a dynamic scaling where the linear velocities are scaled in proportion to the characteristic lengths and the angular velocities remain unchanged between model and prototype. We are not aware of any efforts where this kind of scaling has been attempted.

#### 3.4.2 Cornell University Activities

The efforts of Cornell University were directed toward the determination of the pertinent soil mechanical properties (stress-strain or constitutive relations) as they relate to vehicle mobility. Under ORMR subcontract, Cornell University issued two reports.<sup>49, 50</sup> The first was concerned with the identification of the conditions where fine grain soils would be expected to produce mobility problems, while the latter was concerned with the simulation of these conditions in laboratory experiments. In the following, the principal findings and conclusions of the reports are presented.

Surface soils generally are a mixture of three phases: mineral particles, water and air. An extremely important aspect of the soil behavior is the rate at which pore fluids move relative to the solid particles

under the influence of externally applied loads. In materials having large pores, such as coarse sands and gravels, full drainage of the pore fluids might be expected during the vehicle passage. Such soils, if not in a loose state, do not, by themselves, constitute a serious impediment to vehicle mobility.

The soils which tend to produce the most serious mobility problems have very small pores and little or no drainage of pore fluid can occur during vehicle passage. The behavior of these soils is largely controlled by the initial pore pressure conditions and the relation between the solid and fluid phases.

A clay soil of low plasticity (so-called Newfield clay) and a silica silt were tested using an unconfined, triaxial compression test. Both remolding and compaction processes were employed in preparing the soil samples. Soils at almost fully saturated conditions were prepared by the remolding process. Partly saturated soils were obtained through both compaction and by allowing remolded samples to dry.

The principal finding with the partly saturated soils (both clay and silt) was that the strengths were generally in excess of 15 psi and, consequently, would not be expected to cause mobility problems for normal vehicle ground pressures. On the other hand, when the strength of the clay is low enough to cause difficulty, its water content is so high that any volume changes under undrained conditions are not significant. The remolding process led to flabby stress-strain curves which ideally are not suited to investigations relating stress and strain fields. Furthermore, this situation is not typical of those likely to be encountered in the field except after multiple passes of vehicles.

Briefly, the soil conditions perhaps most responsible for vehicle immobilization are fine-grain clays at near-saturation behaving in virtually an incompressible manner. In addition, the ultimate shear strength should be low with flow occurring at moderate strains.

The follow-up effort<sup>50</sup> attempted to determine feasible ways to duplicate these conditions in the laboratory. The most reasonable procedure would be to consolidate from a slurry, but a fine-grain clay, such as the Newfield clay, could not be consolidated in a reasonable time period. Consequently, fully saturated kaolinite having a coarser grain was investigated. Also, artificial soils, a kaolinite-oil mixture and a plasticine, were tested.

The Cornell University results indicate that it is feasible to consolidate kaolinite to low shear strengths in reasonable time periods. This soil has desirable stress-strain characteristics which would tend to duplicate conditions likely to be encountered in the field. Furthermore, the artificial soils may be useful in investigating specific conditions related to the soft-soil mobility process.

#### 3.4.3 Hydronautics, Inc. Activity

Under ORMR subcontract, Hydronautics, Inc. investigated the problem of a rigid cylinder being driven over a rigid-plastic solid.<sup>51</sup> This preliminary investigation relied on classical plasticity theory with some consideration given to how inertia effects might influence the solution.

The purpose of this study was to solve, in a basic way, the problem of soil flow beneath a wheel under some simplifying assumptions. While existing approaches use empirical results obtained from static tests of plates on the soil surface and apply them to the moving wheel, in this study the whole region of soil flow beneath the wheel was considered. The

solution of the problem follows the lines of the classical applied mechanics - the soil behavior is represented by material constitutive equations, the stresses and velocity fields are interrelated through the equations of motion, and the particular solution for the wheel is obtained by integration with the appropriate boundary condition.

Unfortunately, the difficulties encountered in such a type of solution are formidable. The most important of them is the lack of a good mathematical representation of the soil behavior in form of constitutive equations. However, even if some simplified constitutive equations are adopted, the exact integration of the equations of motion in the wheel case seems impossible at this stage.

In this preliminary study, the problem was simplified by adopting the following assumptions: (1) the soil behaves like a rigid-plastic incompressible material, (2) the wheel is two-dimensional and rigid, (3) the motion is steady, and (4) the soil surface is plane and unperturbed far from the wheel. Assumption (1) limits the applicability of the results to soft clay with a high water content although, even in this case, the plastic-rigid model is a foregoing simplification.

The general equations of plastic flow are discussed, with emphasis on the inertial effects which generally are not negligible. A plastic flow pattern is suggested and the quasi-static equations of flow are integrated in two regions of the plastic zone. An approximate solution provides the magnitude of the recovery angle, the vertical and horizontal forces, and the torque acting on the wheel as functions of wheel radius, sinkage and shear stress along the wheel (assumed constant on the bow portion). A minimum slippage necessary to maintain the shear stress on the wheel is found.

Considering the highly empirical character of existing theories, it is felt that the present work, in spite of the above simplifications, constitutes a step forward in the understanding of soil-vehicle interaction. However, this is only a first step and to establish the validity of the approach, the results, particularly the soil flow pattern and the stress distribution, must be compared with experimental measurements.

#### 3.4.4 Instrumentation Survey

The purpose of the continuing survey of instrumentation is to support the ORMR soil mechanics effort by measurement in the interior of the soil. Methods applicable to laboratory soil bins and to soils in situ are of interest.

The desirability of an instantaneous record of the entire flow region in a marker plane under a moving wheel was mentioned in the discussion on the visioelasticity method (Section 3.4.1). Specifications for soil bin dimensions and for recent, commercially available flash X-ray apparatus to meet these conditions were established. The specified apparatus also has a faster repetition rate than currently used equipment, which makes it suitable for observing transient phenomena, such as the flow field under an indenter.

The suitability of microwaves, the only other electromagnetic region in which soil has significant transparency to electromagnetic radiation, was also explored. The necessary information on their absorption and scattering in soil was acquired by experiment since available published information was inadequate. The inherent advantage of microwaves over X-rays would be that the former have significant reflection in soil and thereby, offer more favorable transmitter and receiver location, particularly in eventual field measurement. However, our survey indicates that the inherent higher accuracy of X-rays and their lower heating effect far outweigh the gains that could be achieved by development of microwave instrumentation for measurement of soil displacement.

The uniformity of test bed preparation could be monitored by a small gage sensitive to local pore water pressure and local changes under transient loads could be measured if such a gage had a sufficiently fast response time. A miniature, quick-acting pore pressure gage is currently not available. Our survey indicates the feasibility of developing such a gage. Remote (i.e. wireless) transmission of information by imbedded sensors of pressure, temperature or strain is within state-of-the-art as indicated by our survey of such usage in other disciplines.

In Appendix G we present detailed results of our effort on measuring marker displacement by X-ray or microwave methods, and on measuring soil properties by small sensors embedded in the soil.

#### 3.4.5 Interparticle Force Study

In theory, if the two-body force acting between two soil particles were known, then by allowing various degrees of particle interactions, the total energy of the system at any time could be found by statistical mechanics. If external work is done on the system, then the total energy of the system will be changed. Presumably, this change could be related to the active particle interactions to account for an overall energy balance.

In our second Semiannual Technical Report <sup>4</sup> we pointed out that such calculations are not currently feasible because the present state of interparticle force theories is inadequate and these theories are not directly applicable to natural soils. To further explore the current status of the theories an interparticle force calculation was performed for a pure clay mineral (montmorillonite). In the calculation, edge and shape effects were neglected; composition was accounted for only by the characteristic surface charge of the mineral. In Appendix II we report the resulting estimate of the magnitude of interparticle forces, which in soil mechanics text books is usually given only qualitatively.

#### 3.4.6 Fabric Studies

Chemical composition, water and air content are not sufficient to characterize the response of soil to load. At a given water content the shear strength of clay is highly dependent on its load history - during preparation, in the case of laboratory test beds, or by vehicular and other environmental loads, in the case of natural soils. This prior load history which leads to such different behavior can of course be investigated for each soil composition of interest by systematically varying specimen preparation (remolding and/or consolidating) and by making a large number of strength measurements (e.g. triaxial tests). By means of such tests the response of soil to a large number of preload and test load conditions can be determined, but they do not provide the ability to predict soil response to any load. What is needed for such generalization is description of the interior of the soil prior to loading and an understanding of the physical processes by which the interior configuration is altered as a consequence of loading. Such understanding of this physical structure will lead to better descriptors of soil (e.g. supplementing terms such as field capacity) and will provide interpretation of soil strength tests.

The development of quantitative methods for describing clay fabric\* was therefore initiated. The effort has two immediate goals: (1) Description of soil state by its internal geometry and (2) determination of internal energy dissipation from changes in internal geometry. Achievement of the first objective would be of particular value in assessing uniformity of soil preparation - which was difficult to establish and control in the low-strength kaolinite test beds used in the viscoplasticity method (Section 3.4.1).

---

\* Clay "fabric" is defined by the spacing between particles, their angular orientation and their size. "Fabric" is distinct from "structure" which, in addition, includes consideration of interparticle forces.

Fabric observation must be made in the laboratory and is a laborious process. Nevertheless, the understanding gained by such observations is expected to have long range benefit by laying the foundation (1) for more readily obtained measurements that can be made in the field and (2) for classifying the behavior of different soils under dynamic loads.

It was planned originally to make fabric observations on kaolin specimens taken from the test bed prepared for the rigid wheel experiments at McGill University. A report from McGill University<sup>52</sup> and publications from other universities,<sup>53,54</sup> indicated that techniques for fabric observations were well developed. Development of suitable measures of fabric based on these observations was considered to be an appropriate short-range goal. However, it was soon found necessary to precede such a combined rigid wheel passage - fabric study with further techniques development on especially prepared laboratory specimens.

Common to all methods of fabric study is the problem of extracting and preserving an undisturbed clay specimen in a form suitable for observation. The procedure usually adopted is to replace the clay water by a solid material. The suitability of a series of water soluble polyethylene glycol waxes was explored in the preparation of our specimens. Three techniques, (1) polarizing microscopy, (2) X-ray diffraction and (3) electron microscopy were employed for fabric observation. These investigations are reported in some detail in Appendix I and in a separate report<sup>55</sup> prepared by McGill University under subcontract to CAL. The results are summarized in the following paragraphs.

Fabric observation by polarizing microscopy yields information on the angular orientation of clay particles. At McGill University 25 $\mu$  thick wax-impregnated clay specimens were viewed in plane-polarized light at a magnification of 100. The retardation of the transmitted light, shifted into the visible with the aid of a gypsum red plate, was recorded on color film. The McGill Report contains a series of photographs which

demonstrate drastic color differences between oriented specimens viewed perpendicular and those viewed parallel to the direction in which consolidation pressure was applied. Graded color differences are shown to be characteristic of various degrees of intermediate orientation obtained by variation in clay preparation prior to impregnation. The results at this point are qualitative. The development of quantitative measures of these color differences and their relation with particle orientation appears feasible.

X-ray diffraction is well suited to check out the validity of the polarized light method of determining clay particle orientation. The method is based on identifying the Bragg angles of the plate and narrow faces of the wax impregnated clay crystallites and using the relative intensities of radiation reflected at these angles as a measure of average orientation. Since reflected X-rays can be used in the determination, thicker clay blocks (say 1/2" cubes) can be employed than in polarizing microscopy; the thickness of the examined layers is about the same as in the polarized light method, i.e. 25  $\mu$ . The area over which the measurement is averaged is a characteristic of the diffractometer. In the measurements at CAL it was approx. 1/2 x 1/8 inch. In our measurements two characteristic peak intensities were measured at cube faces perpendicular and parallel to the prior load direction. The trend of the peak ratios was in the proper direction; further work is required to establish accuracies and quantitative relationships for a range of orientations.

Electron microscopy is attractive as a tool for fabric assessment because it can provide information on all three aspects of fabric: particle size, orientation and spacing. It is also the least developed of the three methods of fabric observation under investigation. Specimen preparation is all-important for its success. Our detailed account in Appendix I indicates that a large number of possible combinations of variables in the preparation process were tried and that some success was achieved in obtaining electron

micrographs. Further work is needed to develop the method to the point where it is reproducible, preserves fabric during preparation, and lends itself to quantitative evaluation. The approach planned for the latter is to draw a number of diameters across representative image areas and to measure particle size, spacing and orientation along these diameters. Alternatively, the number of particle-particle contacts along such a diameter might serve as a relative measure of particle spacing.

#### 3.4.7 Particle Surface Study

The need to interpret and predict soil strength in terms of soil parameters can also be satisfied through study of particle surfaces. The advisability and timeliness of such a study was confirmed in a brief survey.

The interfaces between liquid and air, liquid and solid, and air and solid in natural field soils determine the magnitude of such variables as compressibility and adhesion. In natural soils, the interface conditions are largely unknown, and certainly not controlled; it would be a significant contribution to define and carefully control the important interfacial properties of solid-liquid-gas aggregates as necessary for the accomplishment of soil research goals, viz. the simulation and study of a wide range of soil properties in the laboratory. Such artificial soils research would attempt to modify the nature of the solid-solid interactions, by altering the solid surface chemistry, and the solid-liquid interactions by selecting liquids with appropriate surface chemical behavior. Thus it should be possible to simulate the behavior of sand, clay or sand-clay mixtures. It should be noted that the "artificial" soils proposed here differ from those discussed in Section 3.4.2 in that here "artificiality" consists in modifying the clay-water-air system, whereas in the former sense entirely different materials are introduced.

Our survey indicates that presently available detailed knowledge of the molecular structure of organic chemicals permits modification of materials, such as clay, in such a manner that both, the strength of the adhesive bond between the clay and a liquid film and the wettability of this film can be controlled. Very sensitive and yet comparatively simple techniques for measuring the surface properties of such absorbed films are available. In such a study, particle surface modification tests would have to be combined with determination of associated bulk properties.

Two major benefits derivable from the particle surface approach would be (a) information on the actual surface chemical constitution and reactivity of soil particles, with special attention to the influence of organic constituents, and (b) creation of model soils whose surface properties can be defined and/or systematically varied, laboratory-tested, and related to soils occurring in nature.

### 3.5 HUMAN FACTORS

Reference 4 stated that it will be necessary to employ the experimental approach for the acquisition of data to furnish a suitable quantitative understanding of human performance in off-road mobility. The following complementary methods deemed suitable for gathering data were cited:

- a. observing and interviewing operational personnel and trying out the tasks where possible,
- b. testing, in which military vehicles are used to gather data under field conditions, and
- c. conducting simulations wherein data can be gathered inexpensively under controlled laboratory conditions.

The position also taken in Reference 4 was to rely heavily on the introduction of the driving simulator into the loop with the vehicle-terrain model as an alternative to representing the driver by mathematical means.

Efforts have concentrated on items related to (b) and (c) above; namely development of a driving simulator and formulation of a field test program to provide base-line performance against which simulator testing may be referenced.

One of the tools under development within the ORMR program is a driving simulator with which the performance of an existing or postulated vehicle can be examined in the laboratory without resorting to extensive field testing. The simulator which is being developed currently provides a programmed display with only a minimal control over the display by the subject. A video tape recorder with black and white pictures and variable projection speed capabilities is used in conjunction with a television monitor viewed through a virtual-image-forming lens. The variable speed feature allows placing the

apparent speed of the vehicle under the control of the subject. A definition study was made to examine various alternatives and from these delineate a visual environment display system which would be less restrictive to the driver (e.g., a terrain board and its associated equipment) than the "canned" visual display of the presently provided driving simulator. This study which recommends a terrain board and associated equipment is summarized in Section 3.5.1.

The need for motion simulation to supplement the visual display in the driving simulator is discussed in Section 3.5.2. Engineering design of a three degree of motion simulator (pitch, roll and bounce perpendicular to the combined pitch-roll plane) has been completed. A three-quarter scale model of the motion platform has been constructed and has aided in revealing design and assembly problems preparatory to embarking upon the development of the full scale version.

The next step is to construct the motion platform and link it with the V D M and video tape display. Once this has been accomplished, the system can be exercised using visual displays from video tape and terrain profile data obtained in vehicle field tests. A program has been outlined of field tests to obtain quantitative data concerning system performance under various driving conditions and to provide a basis for designing simulator experiments. A summary of the field test plans is given in Appendix J.

The results obtained in the initial experiments will provide first evidence of the appropriateness of the current simulator configuration for simulating the real world. This information will serve as a background for further developing and utilizing the simulator.

Reference 4 also discussed the possibility of increasing mobility through auxiliary information displays and indicated that a probing test using a slipmeter was then in progress. This test was subsequently completed. Briefly, results of the tests indicate that the drivers performed best with

vehicle noise and speedometer cues. Poorer performance was evidenced for the condition where the driver heard vehicle noise and observed the slipmeter but not the speedometer. Although these results did not demonstrate benefits from a slipmeter display, other effects were revealed which could be of importance, e.g., significant differences in total time of traverse and integrated slip for the different drivers. These types of effects suggest the possibility of increasing average speed made good and/or decreasing fuel consumption, when traversing terrain where substantial slip may occur, through the process of driver training. Appendix K contains additional information pertaining to the slipmeter test.

#### 3.5.1 Driving Simulation - Visual

There are many methods for producing a visual display for a driving simulator. The final choices result from tradeoffs of the experiments to be performed and on the fidelity required of the simulation. The course of action chosen in the ORMR program was to implement the simulator in steps. Each step is to add extended capability to the system. This is a cost-saving approach that permits development of the simulator on a firm foundation of knowledge.

It was decided that the first functional simulator could be built before a motion platform was completed and before the vehicle dynamics model was fully implemented. The visual display for the "first-step" simulator sketched in Figure 21 below, consists of a video tape recording played through a television (T V ) monitor. The driver is seated before the monitor and views it through a collimating lens. With the monitor screen placed at the focal point of the lens, the picture appears to be three dimensional in nature. The tape recording is made using a TV camera mounted on a vehicle which traverses the study terrain.

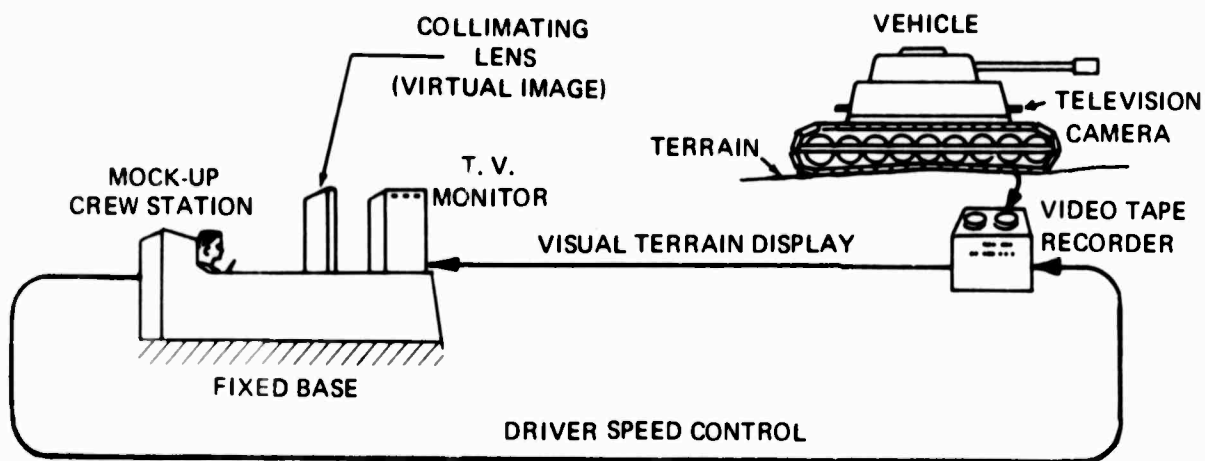

Figure 21 SKETCH OF "FIRST STEP" OFF-ROAD DRIVING SIMULATOR

Thus, the monitor-lens display system forms the core of the visual simulator. By using video presentation, the display may be derived from a wide variety of sources (e.g. video tape, terrain board and computer generated displays) using fully compatible equipment.

The "first-step" simulator, as just described, allows only a programmed route to be traveled; that is, the driver has no control over the path that his vehicle will follow. The driver does, however, have control over the simulated speed of the vehicle in that he can vary the speed of the video tape. The above described direct video recording system is currently being evaluated against a system in which a video transmission is derived from a motion picture. The video tape recording system may also be used in conjunction

with a motion platform. Here while recording the visual data, the motion data may be simultaneously obtained from sensors and recorded directly on audio channels of the video tape or on ancillary synchronized recorders. The motion platform carrying the driver will be synchronized with the visual display. This will allow the driver to experience the vehicle motions recorded at the time of video taping, while at the same time viewing the recorded scene. It must be pointed out that fidelity decreases as the simulated vehicle speed deviates from the speed at which the field test recordings were made. In projected versions of the simulator, the computer-based VDM would control the motion platform according to the driver's control actions, and maintain the proper correspondence between the motion platform and visual display.

While a programmed display is well suited to studies primarily involving vehicle factors (e.g. ride quality, speed control), studies wherein the driver makes path change decisions based on his perceptions should employ an unprogrammed display. A study was made directed toward defining a practicable method for providing a visual environment of this nature. The study revealed that to add this capability, a model terrain (similar to a model railroad layout), at a scale of approximately 1:100, would be most suitable. A gantry surrounding the terrain model and traversing mechanisms would permit vertical and horizontal movement of a TV camera over the terrain model as commanded by the driver via the VDM. An articulated optical pickup on the camera would view the model from scaled driver eye-height. The pickup's articulations would provide roll, pitch, and heading (yaw) as computed by the VDM. The input to the VDM required to compute the roll and pitch would be the ground elevations sensed at each element of the vehicle's running gear. Several methods to handle this particularly difficult sensing problem were examined in the definition study. One method of sensing elevation information is to employ a scale model running gear assembly attached to the probe and in contact with the terrain board surface. The pitch and roll of this assembly can be measured by strain gauges or potentiometers. The drawbacks of such a device are substantial, including such problems as collisions with terrain board features and the need to modify the assembly for each new type of vehicle.

An alternative elevation sensor would be a set of noncontacting devices, one for each running gear element. These sensors could be of the capacitance probe type. While this is more desirable than the contacting sensor, there are still problems requiring considerable engineering development.

The most promising solution to this problem is the storage of terrain board elevations in a computer and their recall according to the X-Y location of the gantry. The study has shown this approach to be feasible.

Other items examined in the visual-display definition study were:

1. methods for increasing the field-of-view of the display;
2. the problems of using a color display;
3. high quality collimating lens systems;
4. environmental stress control;
5. the use of TV projectors instead of TV monitors for generating the visual display; and
6. special video effects.

Additionally, it was determined that several manufacturing concerns exist which build complete simulation systems or system components. It is estimated from their quotations as well as CAL's in-house estimates that the hardware for a basic terrain board simulator would cost on the order of a few hundred thousand dollars. The study concludes that as much as possible of the simulator should be procured from a single source to minimize the possibility of unexpected equipment interface problems in the step by step development of the driving simulator.

### 3.5.2 Driving Simulation - Motion

When operating in an off-road environment the driver must traverse areas where the surface is obscured or where the appearance of the surface does not allow him to discriminate between passable and impassable routes. In many military vehicles vision is obscured. Under military field operational conditions it may be necessary to drive at night with minimal illumination. Even under conditions of optimum visibility it is to be expected that the visual and nonvisual cue systems reinforce each other and that the redundancy or overlap of the information in each system allows a higher general level of performance than would be found by operating under one system alone.

Thus, in order to properly simulate the driving task in an off-road situation, motion inputs must be present. The motion simulation in general must satisfy two separate needs. It must first provide the stress-and fatigue-producing environment characteristic of the true off-road situation. As an example, in a vibration tolerance simulation experiment one should be able to specify a motion environment in much the same manner as one specifies a temperature level or a noise level. Secondly, and more significantly, with faithful motion simulation it should be possible to provide accurate representations of the accelerations and displacements which act as non-visual cues of the response of the vehicle simulated. In a driving simulator, motions should be generated in concert with the appropriate visual display in order to immerse the simulator driver in a synthesized environment that has the "feel" of the field situation being simulated.

While the perfect simulator would be capable of duplicating real vehicle movement in six degrees of freedom, it is not feasible to construct such a simulator for laboratory use. A compromise must be made between complete simulation and less than complete but adequate simulation, which affords the operator sensitivity to the "feel" of the vehicle and environment being simulated. CAL has given much thought and study to the needs of the off-road operator and the problems peculiar to operation in an off-road environment in selecting the motions which must be simulated. Vehicles operating in off-road environments experience large amplitudes and/or accelerations in pitch,

roll and bounce. Hence motion cues as well as visual cues are required for these degrees of freedom if realism is to be preserved. The very fact that severe translations and accelerations do occur in these motions tends, however, to restrict the speed at which vehicles proceed off-road with the result that longitudinal, lateral and yaw motions and accelerations are usually limited.

The yaw motion that is generated in the off-road driving situation is considered to have a low degree of utility in providing cues and it is felt that it can be simulated sufficiently using visual cues alone. Simulation of the longitudinal and lateral degrees of freedom might be desirable, but the difficulty in providing practically, sufficient mechanical travel, is the primary reason for their omission. Although, perception of acceleration along the longitudinal and lateral axes of the vehicle is relatively important in the operation of most surface vehicles, the slow rates of motion off-road decrease the importance of nonvisual perception of changes in rate of motion for these axes. Further, it is believed that the effects of longitudinal and lateral accelerations can be simulated by supplementing the motions produced by the visual display with small amounts of pitch and roll motion superimposed on the vehicle excursions in roll and pitch. Pitch unaccompanied by corresponding visual changes would tend to make the subject feel a forward or backward acceleration. By the same token, roll without a corresponding image change would simulate side slip.

Two three degree of freedom moving base motion simulator configurations were explored. One design consisted of a pitch-roll platform topped by a crew station which is driven normal to the platform for the bounce mode. This design, sketched in Figure 22, provides for a payload of 1000 pounds, pitch amplitudes of  $\pm 45^\circ$ , roll amplitude of  $\pm 30^\circ$  and bounce displacements of  $\pm 6$  inches. The engineering design details of this "short-throw" motion simulator may be found in Appendix L.

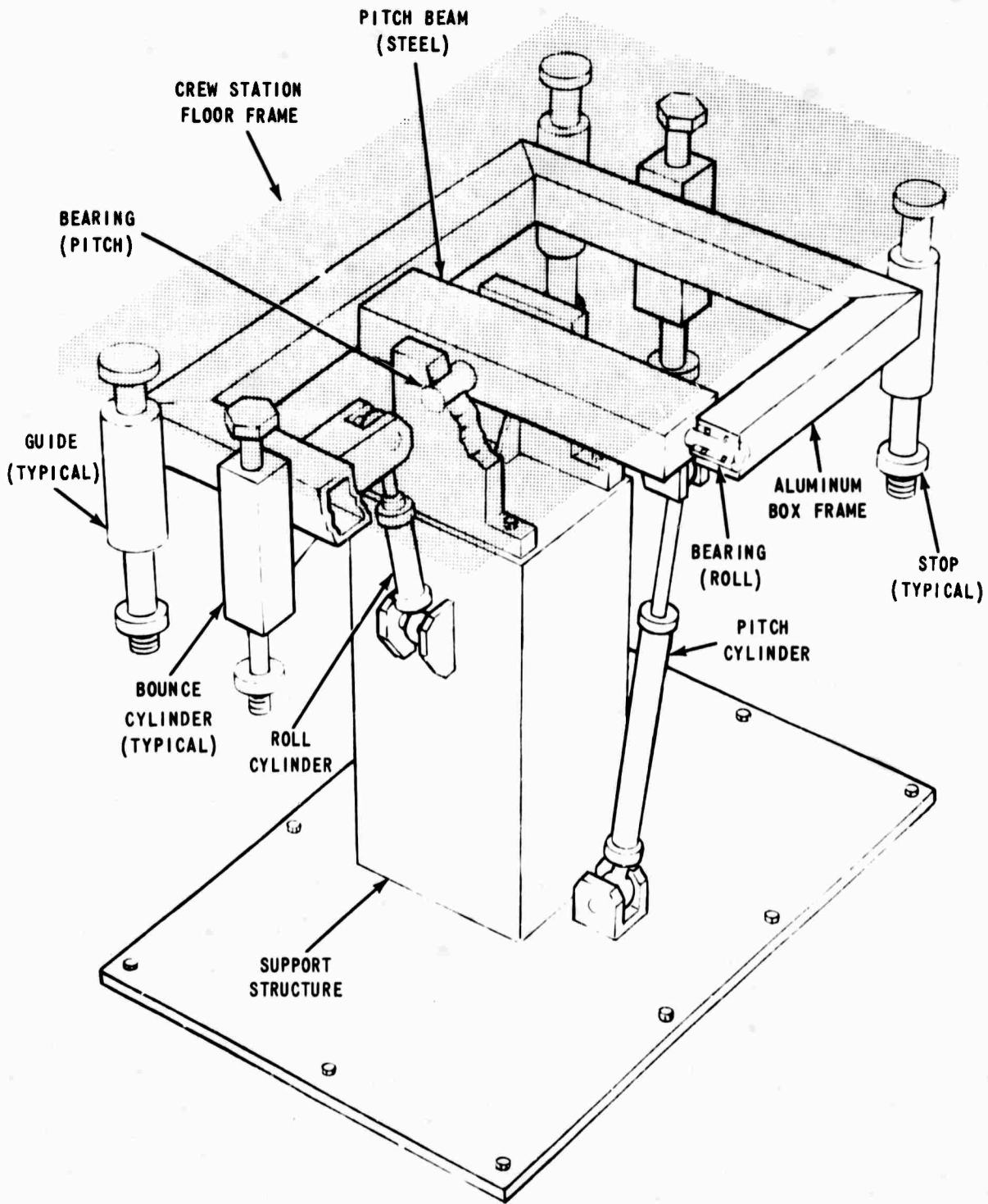

Figure 22 "SHORT-THROW" MOTION SIMULATOR - DESIGN SKETCH

The second design employs a platform which is driven differentially by means of two hydraulic cylinders to provide bounce and pitch motions. A rotary hydraulic actuator is used to drive a frame in the roll mode. Figure 23 gives a sketch of this longer throw design which provides a bounce amplitude ± of 2.0 feet at 0° pitch and ± 1.0 foot at ±45° pitch. A maximum roll angle of 40° is provided. In Appendix L it is shown that this latter design requires twice the hydraulic flow rate of the former design; a longer pitch cylinder stroke, demanding more stringent structural requirements; and the additional requirement of a rotary actuator.

The former design was selected as the primary candidate for the motion platform because of the less severe design requirements and the belief that the ±6.0 inches in bounce coupled with suitable feedback circuitry could be made to provide sufficient simulation of off-road vehicle bounce motions.

An approximately three-quarter scale model of the selected design was constructed with the following objectives:

- (a) to determine the feasibility of the major design concepts;
- (b) to identify factors that may have been overlooked and which must be considered in the full-scale version; and
- (c) to experiment with safety concepts.

The successful operation of the model supports the choice of the design concepts in this program. Preliminary studies with a motion picture camera mounted in the driver's position lends further support to the efficacy of the design.

The initial calculations for the model were based on a somewhat simplified design concept in order to make the equations of motion more manageable. It was anticipated, therefore, that certain factors requiring design modifications would not become apparent until the working model was studied. One such factor, top heaviness in the model when the hydraulic power was off, indicated that changes in the full-scale design were required to lower the

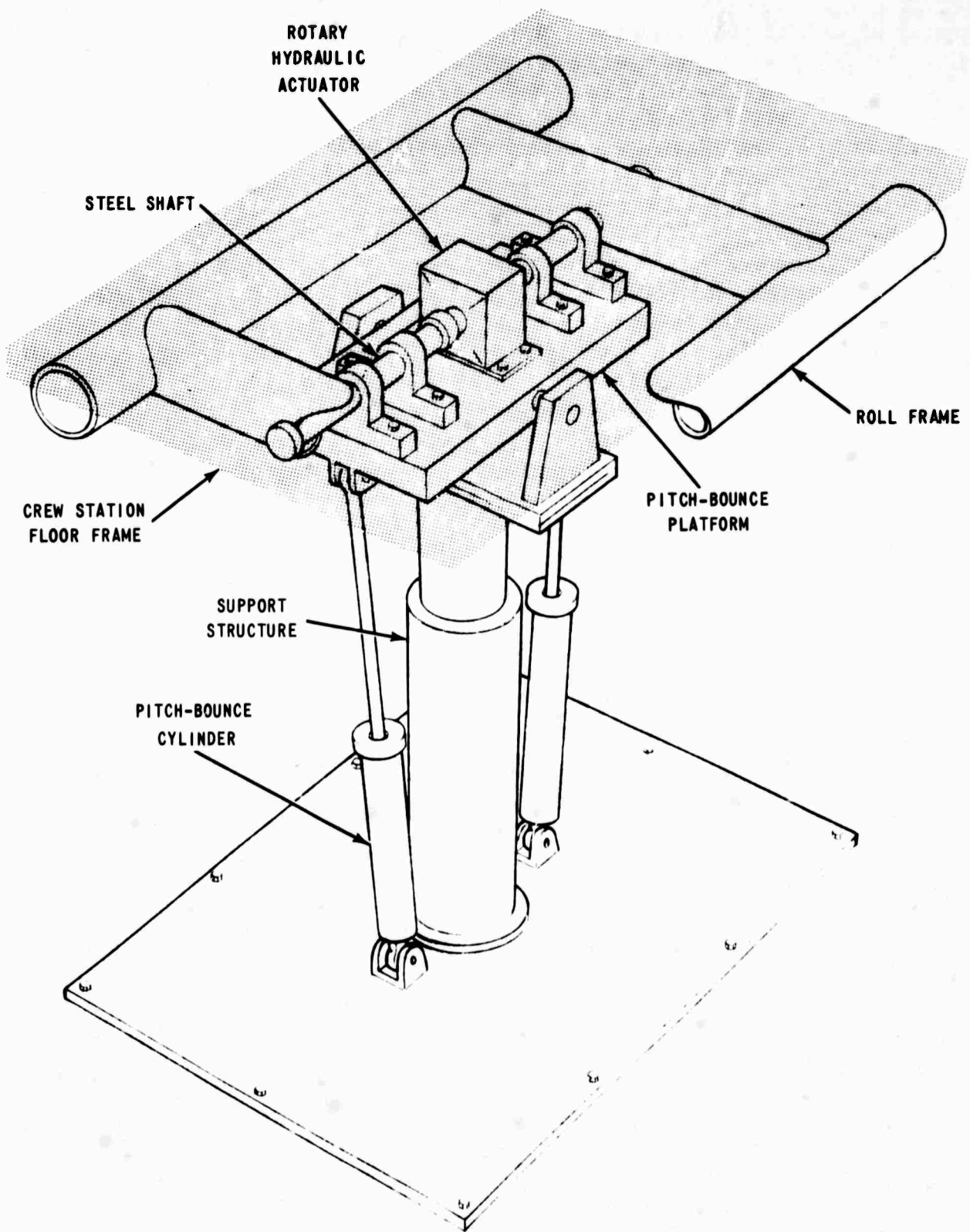

Figure 23 "LONG-THROW" MOTION SIMULATOR - DESIGN SKETCH

center of mass of the simulator. These changes can be effected by lowering the crew station, through the use of a stepped floor frame, lower guides, and lower cylinder supports and brackets. A second factor requiring design modification, determined from studying the model, was shaft stress. The stresses in the model shafts were greater than those calculated from the simplified equations of motion. In light of this experience with the model, larger shafts have been recommended.

Springs were added to the mechanical stops of the model in order to cushion the shock in case of sudden failure of the electrical control. One set of springs were installed for each of the three modes of motion. An over-travel limit switch for each mode, similar to the ones used in electrodynamic shakers, is deemed necessary in a full-scale version on the basis of experience with the model.

The engineering design effort and the model construction and checkout indicate that it is possible to build a "short-throw" motion simulator having considerable capability.

The motion platform together with the visual displays discussed in the previous section will furnish the capabilities of a driving simulator such as that shown in Figure 24. It may be seen in the figure that the motion platform may be used with video tape displays as well as with the more advanced terrain board displays.

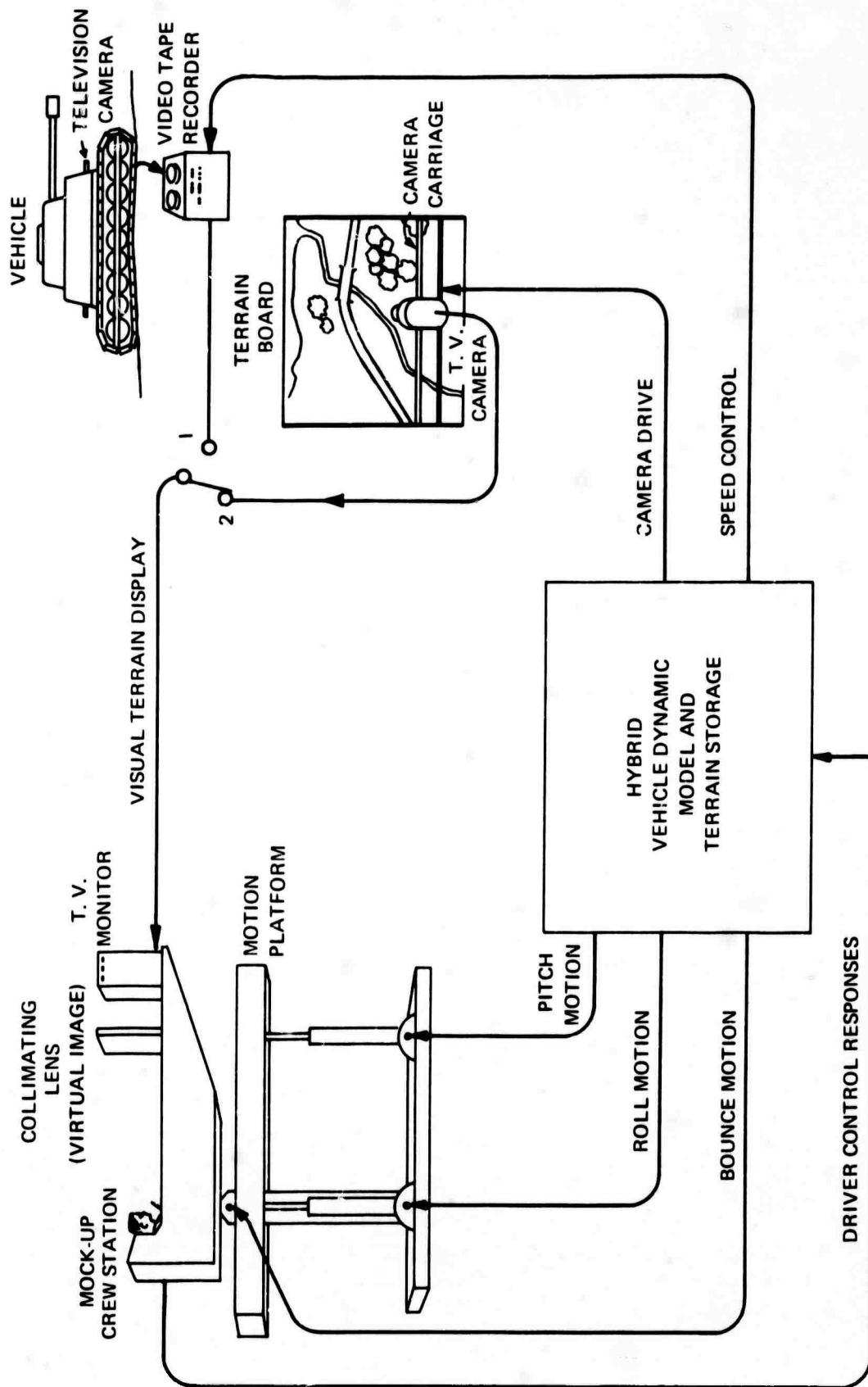

Figure 24 OFF-ROAD DRIVING SIMULATOR - CONCEPTUAL SKETCH



### 3.6 SYSTEMS STUDIES

The general purposes of the systems studies have been to

- (1) delineate specifically to whom we hope to supply information, for what purposes and in what formats; and
- (2) organize methods and tools to help generate this information.

The approach to these problems has been based not only on our own thinking but more important on the thinking of the potential information users themselves. It is incumbent upon us to develop only such data as are needed, with priority placed on value to specific information users.

Early in our ORMR program, an effort was made to categorize the basic functions which contribute to off-road mobility. Twelve such functions were called out<sup>1</sup> on the basis that the information needs for proper performance of each function could be substantially different from the others. These twelve functions are: (1) research; (2) testing: laboratory, acceptance, training school and field; (3) high-echelon planning; (4) specification; (5) development, design and fabrication; (6) evaluation-selection; (7) allocation; (8) maintenance; (9) driver selection and training; (10) reconnaissance to aid in route selection and preparation; (11) field deployment; and (12) commanding and driving the individual vehicle.

Many difficult questions must be faced in the process of making the necessary decisions which arise during the performance of these important basic functions which comprise mobility. Our earlier ORMR survey

studies<sup>1</sup> had shown that more adequate methods and tools were needed to cope with these problems. As a result, we have directed effort toward structuring of such methods and tools.

Development of a Vehicle Dynamics Model (VDM) and a driving simulator has been discussed in sections 3.2.1 and 3.5. Systems studies in conjunction with these modeling efforts have been aimed toward helping determine the capabilities the models should (and could) have. Also, as the modeling in these two areas has progressed, attention has been given to the ultimate goal of VDM and driving simulator compatibility, to allow incorporation into a Vehicle System Dynamics Model (VSDM) for predicting performance in selected unit environments of the overall driver-vehicle-terrain system.

Perhaps more important, systems analysis effort has been directed to the questions: (1) "What data is desired from the above mentioned models?" and (2) "How is this data to be processed when it has been generated?" Answers to these questions naturally derive from answers to the questions of user needs addressed on the previous page. As a result, the structuring of an Aggregated Performance Model\* (APM) has been undertaken<sup>4</sup>. Its main purpose will be to process performance (and later, cost) data and cast them into meaningful assessments of various mobility problems. An important part of the APM formulation process is to establish an appropriate format for presentation to each potential user of data aggregated at the statistical level most valuable to that particular user.

In the subsections to follow, two other systems efforts will be summarized.

---

\* "Aggregated Performance Model" has in previous writings been referred to as "Phenomenological Model".

The first was a study to develop techniques for matching off-road vehicles to the terrain in which they must perform. Results from early efforts at CAL<sup>4</sup> to examine vehicle-terrain matching on a Go/No-Go basis proved promising. Therefore, the study was expanded into a joint effort, with WNRE, Inc. as subcontractor. Results of this work are detailed in References 5, 38 and 56.

The second effort was a study of the life cycle development of four U.S. Army vehicles designed for off-road applications. The concept development, engineering design and test and evaluation phases pertaining to the evolution of the vehicles were analyzed together with the operational history of each vehicle. This investigation was directed toward the identification of the mobility factors whose modification could lead to improved performance. A complete description of this study is documented in Reference 57. A condensed version of the research directed specifically at mobility requirements and testing is contained in Reference 7.

### 3.6.1 Vehicle-Terrain Matching

The joint CAL-WNRE effort had four major objectives:

- (1) Development of a method for formulating testable performance specifications for vehicles adapted to specific off-road terrain.
- (2) Illustration of this method, using several sample off-road vehicles and a selected study area in Thailand described by mobility-significant environmental maps.
- (3) Development of computerized techniques for processing the large quantities of data required for use in this or similar methods.

- (4) Demonstration of how the computer techniques and data developed in (1), (2) and (3) can be applied to adapting an off-road vehicle for improved conformity to a specific terrain.

Work toward objectives (1), (2) and (4) is summarized in this section of the report; (3) has been summarized in section 3.3.4.

One reason for the first objective is the statement in the recent literature (e.g., Ref. 58) which suggests that much of the trouble in off-road mobility arises from the consistent lack of viable, testable, off-road performance specification in new vehicle design and development procedures. The approach taken toward remedying this situation has been to cast vehicle specifications in terms of performance boundaries which define the most severe types of terrain in which a proposed vehicle must be able to operate. The key to success in this approach is to define such boundaries in terms of a manageable number of critical sets of conditions which can serve as a basis for specifying a workable number of performance tests. The philosophy is that, if a vehicle can traverse these critical terrains, it will successfully negotiate less severe conditions within the boundaries.

In order to cast the above concept into practical terms, it was felt that the performance boundaries should be established for a variety of existing vehicles to provide some bases for judgement. In order to capitalize on recent operational experience, two Army vehicles currently in extensive use in Southeast Asia, the M113 Armored Personnel Carrier (tracked) and the M41 6x6, 5-ton truck (wheeled), were selected as candidates. In addition, two more advanced vehicles were included the 4x4, 5-ton GOER and the 2-1/2-ton 10x10 Vehicle for Mobility Exercise A (VMEA). The tracked M29C Weasel, whose generally good performance capabilities are well known, was added as a control vehicle to check that results of the study conform realistically to field experience.

Environmental data were taken from maps prepared under Project MERS<sup>59</sup> but the process developed can accommodate any map data of that general type and resolution. An 18x24 km region of Thailand, composed of many terrain types common in Southeast Asia, was selected as the main study area. The MERS family factors for this region were digitized on a 100x100 m grid. Performance of the vehicles was then examined in the many types of terrain which characterized the study region.

With the sources of vehicle and terrain inputs thus established, the study proceeded to outline and demonstrate the procedure employed in formulating specifications in terms of quantitative performance requirements, which will assure that a vehicle can achieve a desired level of Go/No-Go capability in the specified terrain. The basic approach is illustrated by the following example.

Suppose failure to traverse a given region could be caused by either excess slope, soil softness, vertical obstacle height, or various combinations of the three. The performance envelope of a given vehicle could then be represented by a surface such as shown schematically\* in Figure 25. The intercept on each axis is the critical value for each impedance factor acting by itself. The rectangular solid determined by these intercepts, therefore, envelops the region of possible go. However, since there would usually be reinforced demands on the vehicle performance when two or more impedances act simultaneously, the actual performance envelope that could be realized would be a surface within the rectangular solid encompassing a lesser volume.

The first step toward determination of the actual performance surface is to establish a set of engineering criteria to be used for testing Go/No-Go in specified environments. The first-cut version of such criteria,

---

\* While the figure shown here is three dimensional, it was necessary in the study to use as many as six dimensions in some cases.

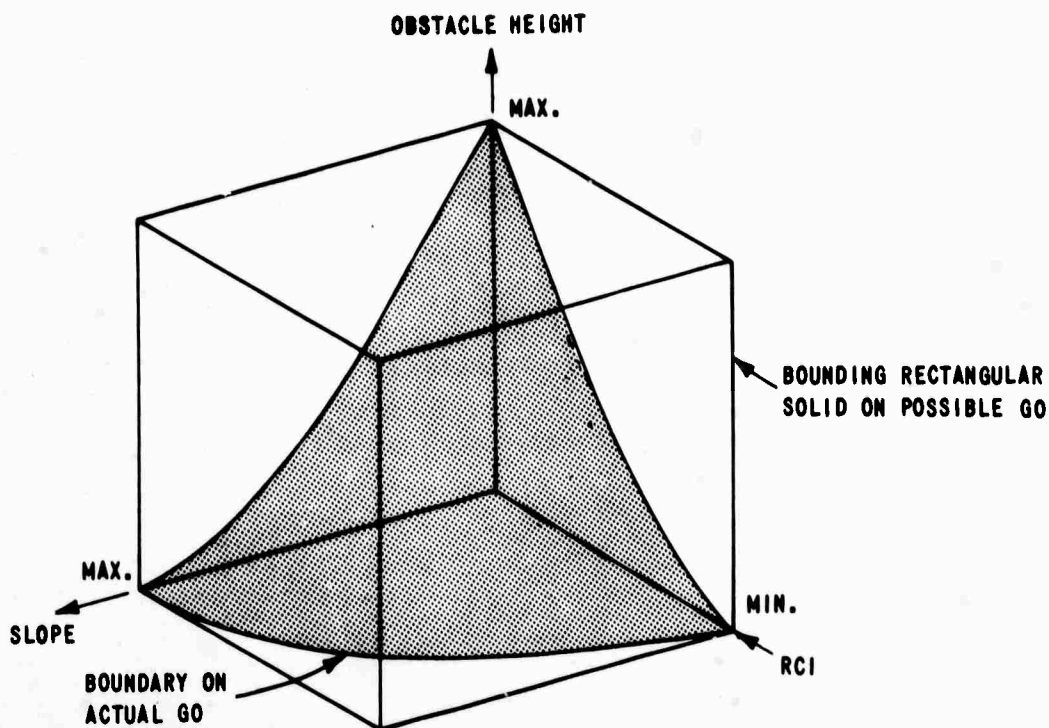

Figure 25 PERFORMANCE BOUNDARY

used in the CAL/WNRE study, is summarized in Tables 4 and 5 respectively for areal and lineal hydrologic terrain features\*. The first listing constitutes a partially ordered set of static tests. In many cases in Table 4 a test farther down the list consists of combinations which present increasing difficulty and which subsume one or more of the tests above it. In Table 5 however, the order in which the static tests are run is essentially the order in which the successive vehicle-terrain confrontations occur as a vehicle attempts to exit from a stream or stream bed. These tests were computerized and two basic sets of computer inputs were prepared: (1) a listing of vehicle design specifications and (2) a compilation of terrain features. Both are described in detail in Reference 38. The preparation of terrain data is discussed briefly here.

---

\* It is noted that the lineal feature tests concentrate entirely on fording or swimming, and egress from the hydrologic obstacle, in view of the fact that these constitute the most frequent causes of hydrologic No-Go.

Table 4 GO/NOGO TEST SEQUENCE FOR AREAL TERRAIN FEATURES

TEST (AND FAILURE) CODE	TEST DIRECTION	DIAGNOSTIC COMPARISON	BASIC TERRAIN FACTORS EXAMINED				MEANING WHEN FAILURE (CODE) IS INDICATED	SCHEMATIC REPRESENTATION
			Basic Slope	Soil Strength	Vegetation	Obstacle Team		
A	Uphill	Basic slope vs. torque-limited gradeability.	X	-	-	-	Vehicle low-gear torque limited gradeability is insufficient to surmount basic grade.	
	Downhill*	Basic slope vs. downhill control stability.	X	-	-	-	Slope is greater than 100%.	
B	Uphill	Basic soil strength vs. VCI.	-	X	-	-	Basic soil strength is inadequate for operation (including maneuver) in smooth level terrain.	
	Downhill*	No test.*						
C	Uphill	Spacing of large trees vs. vehicle maneuver requirements.	-	-	X	-	Single trees too large to push over, based on vehicle low-gear torque, are too close together.	
	Downhill	No test.						
D	Uphill	Spacing of small trees vs. vehicle torque-limited thrust.	-	-	X	-	Trees small enough to be overridden singly, based on low-gear torque, are so closely spaced that vehicle thrust is nonetheless inadequate.	
	Downhill	No test.						
E	Uphill	Vertical obstacle height vs. basic vehicle capability.	-	-	-	X	Vertical obstacle height is greater than basic vehicle limit. (Vertical obstacles = a .75")	
	Downhill	No test.						
F	Uphill	Vehicle angle of approach vs. obstacle angle.	-	-	-	X	Vehicle nose interferes with obstacle before running gear can make contact.	
	Downhill	No test.						
G	Uphill	Male obstacle configuration vs. belly clearance.	-	-	-	X	Vehicle bellies on male obstacle (side elevation only -- no test for normal tracked vehicles).	
	Downhill	No test.						
H	Uphill	Vehicle belly clearance vs. ditch edge.	-	-	-	X	Vehicle bellies on ditch edge (side elevation only -- no test for normal tracked vehicles).	
	Downhill	No test.						
I	Uphill	Dummy test.	-	-	-	X	Intended to check for obstacle spacing and dimensions which might trap a vehicle, but no terrain dimensions of this order were present in the study region so test was not detailed.	
	Downhill	No test.						
J	Uphill	Soil-limited traction** vs. grade.	X	X	-	-	Insufficient net traction developed at soil-vehicle interface** to negotiate basic grade.	
	Downhill	Soil-limited traction** vs. grade.	X	X	-	-	Traction plus grade assist insufficient for forward progress down the slope.	

\*Except for test "A," which was assigned a revised meaning for downhill tests, main factor tests were not repeated in the downhill sequence for obvious reasons.

\*\*Where soil-limited net traction is greater than torque-limited traction the torque-limited value is used rather than the soil-limited value, in all tests where the soil-limited value is called for.

**Table 4 GO/NOGO TEST SEQUENCE FOR AREAL TERRAIN FEATURES (CONT.)**











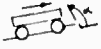





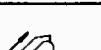

TEST (AND FAILURE) CODE	TEST DIRECTION	DIAGNOSTIC COMPARISON	BASIC TERRAIN FACTORS EXAMINED				MEANING WHEN FAILURE (CODE) IS INDICATED	SCHEMATIC REPRESENTATION
K	Uphill	Spacing of large trees vs. vehicle maneuver requirement.	X	X	X	-	Single trees too large to push over, based on soil-limited vehicle traction <u>less</u> grade load, are too close together.	As test "C," but operating upgrade, under soil strength constraints.
	Downhill	Spacing of large trees vs. vehicle maneuver requirement.	X	X	X	-	Single trees too large to push over, based on soil-limited vehicle traction <u>aided</u> by the grade, are too close together.	As test "C," but operating downgrade, under soil strength constraints.
L	Uphill	Spacing of small trees vs. vehicle soil and grade limited thrust.	X	X	X	-	Trees small enough to be over-ridden singly, based on soil-limited vehicle traction <u>less</u> grade load, are so closely spaced that vehicle thrust is nonetheless inadequate.	As test "D," but operating upgrade, under soil strength constraints.
	Downhill	Spacing of small trees vs. vehicle soil and grade limited thrust.	X	X	X	-	Trees small enough to be over-ridden singly, based on soil-limited vehicle traction <u>aided</u> by the grade, are so closely spaced that vehicle thrust is nonetheless inadequate.	As test "D," but operating downgrade, under soil strength constraints.
TESTS M <sub>V</sub> , N <sub>V</sub> , AND D <sub>V</sub> FOR WHEELED VEHICLES ONLY								
M <sub>V</sub>	Uphill	Vertical obstacle height vs. vehicle capability revised to reflect soil strength and grade effects on traction.	X	X	-	X	Vertical obstacle height is greater than vehicle limit as determined by soil-limited vehicle traction <u>less</u> grade load (Vertical obstacles = α > 75°)	
	Downhill	Vertical obstacle height vs. vehicle capability revised to reflect soil strength and grade effects on traction.	X	X	-	X	Vertical obstacle height is greater than vehicle limit as determined by soil-limited vehicle traction <u>aided</u> by grade. (α > 75°)	
N <sub>V</sub>	Uphill	Non-vertical obstacle traction requirement vs. soil and grade limited vehicle traction.	X	X	-	X	Available soil-limited traction, reduced by the grade load, is <u>insufficient</u> for obstacle negotiation.	
	Downhill	Non-vertical obstacle traction requirement vs. soil and grade limited vehicle traction.	X	X	-	X	Available soil-limited traction, <u>aided</u> by the grade, is <u>insufficient</u> for obstacle negotiation.	
D <sub>V</sub>	Uphill	Combined grade and obstacle face slope vs. soil-limited vehicle traction.	X	X	-	X	The obstacle face is long enough to accommodate the vehicle, and the combined slope of the obstacle face and the base grade requires more traction than available.	
	Downhill	Combined grade and obstacle face slope vs. soil-limited vehicle traction.	X	X	-	X	The obstacle face is long enough to accommodate the vehicle, and the combined slope of the obstacle face and the base grade requires more traction than available.	
TESTS M <sub>T</sub> AND N <sub>T</sub> FOR TRACKED VEHICLES ONLY								
M <sub>T</sub>	Uphill	Initial obstacle traction requirement vs. soil and grade limited vehicle traction.	X	X	-	X	Available soil-limited traction, reduced by the grade load, is <u>insufficient</u> to begin obstacle negotiation.	
	Downhill	Initial obstacle traction requirement vs. soil and grade limited vehicle traction.	X	X	-	X	Available soil-limited traction, <u>aided</u> by the grade, is <u>insufficient</u> to begin obstacle negotiation.	
N <sub>T</sub>	Uphill	Final obstacle traction requirement vs. soil and grade limited vehicle traction.	X	X	-	X	Available soil-limited traction, reduced by the grade load, is <u>insufficient</u> to complete obstacle negotiation.	
	Downhill	Final obstacle traction requirement vs. soil and grade limited vehicle traction.	X	X	-	X	Available soil-limited traction, <u>aided</u> by the grade, is <u>insufficient</u> to complete obstacle negotiation.	

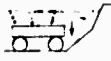
Table 5 GO/NOGO TEST SEQUENCE FOR LINEAL TERRAIN FEATURES

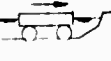
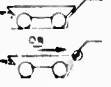
TEST (AND FAILURE) CODE	DIAGNOSTIC COMPARISON	BASIC TERRAIN FACTORS EXAMINED				MEANING WHEN FAILURE (CODE) IS INDICATED	SCHEMATIC REPRESENTATION
		Water Depth	Soil Strength	Lower Bank Geom.	Upper Bank Geom.		
R	Water depth vs. vehicle fording ability (non-swimming vehicles only).	X	-	-	-	Water depth exceeds vehicle fording capability.	
S	Upper bank steep vs. vehicle floating attitude (swimming vehicles only).	X	-	-	X	Vehicle running gear cannot make useful contact with the bank.	
T	Basic soil strength vs. VCI.	X	X	-	X	Basic soil strength is inadequate for simple operation on smooth level ground (with or without buoyancy effects, as appropriate).	
U	Lower bank geometry vs. vehicle configuration.	-	-	X	X	Lower bank presents either a vertical obstacle beyond basic vehicle capability, or there is angle of approach interference.	
V	Lower bank configuration vs. net vehicle traction.	X	X	X	-	Traction required to surmount lower bank exceeds soil-limited traction available (including buoyancy effects where present).	
W	Upper bank geometry vs. vehicle configuration.	-	-	X	X	Upper bank presents either a vertical obstacle beyond basic vehicle capability, or there is angle of approach interference.	
X	Upper bank configuration vs. net vehicle traction.	X	X	X	X	Traction required to surmount upper bank exceeds soil-limited traction available (including buoyancy effects where present).	
Y	Upper bank configuration vs. net traction plus 50% GVM outside thrust assist.	X	X	X	X	Deficit in required traction is more than 50% of gross vehicle weight.	
Z	Upper bank configuration vs. vehicle belly clearance.	-	-	X	X	Vehicle bellies on ditch edge (side elevation only -- no test for normal tracked vehicles).	

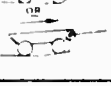
The digitized information on the surface composition, geometry and vegetation maps was combined by computer, just as if transparencies of the three maps were overlaid, into a consolidated digitized map for areal features. The hydrologic and surface composition data were similarly combined into a second map of lineal features. The result is a set of new map units, or "unit terrains", which are unique combinations of the original map units used on the parent MERS maps.

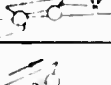
In a given area, there is considerable natural correlation among them, reinforced by land culture, so that only 467 consolidated areal units were in fact required to describe the study region fully. A total of 118 consolidated map units served to define all of the distinct high water hydrologic and surface composition situations in the study region and 107 units defined the low water situations.

A great saving in labor was realized as a result of the consolidation process, because it was not necessary to check for Go/No-Go at each of the 40,000 points on the 100 meter digitized grid of the study region. Instead, the checks had to be run only for the much smaller number of areal and lineal units. After that, only a simple computerized substitution process was required to develop Go/No-Go maps of the complete grid. Figure 26 is a sample of such a map. It is based upon characteristics of the M113. The map was obtained by photographic reduction from six IBM printout sheets\*. Go is indicated by blank spaces in the areal terrain and by slashes (/) in the streams. Letters represent No-Go caused by vehicle failure on the correspondingly lettered test in Tables 4 and 5.

An appropriate aside, at this point, is a brief description of the context in which No-Go is interpreted. Certain terrain impedances must be interpreted as unconditional No-Go, even allowing moderate assistance (e.g., winching). Examples could be deep water or impassable marsh land throughout an entire 100 meter square area. In many cases, however, No-Go must be

---

\* No attempt was made for purposes of this report to correct the distortion of relative dimensions in the computer print-out.



Figure 26 GO/NO-GO MAP FOR M113

considered conditional. For example, certain types of insurmountable obstacles in a square might be avoided by carefully threading a path so that in reality only a time penalty should be assessed. Therefore, since the environmental data used did not contain the necessary information, interpretation of the severity of No-Go must depend on judgment based on the type of failure and on auxiliary information obtained from the topographic map. This situation, along with other aspects of the study, once more leads to the conclusion that the existing environmental data base is neither broad enough nor detailed enough to permit a complete assessment of vehicle-terrain interaction, even on a Go/No-Go basis. More accurate representation is needed of vehicle running gear interaction with soft soil and of mechanisms relating geometrical vehicle configuration to hang-up on (or in) obstacles.

Returning now to testable performance specifications, we note that Go/No-Go data, similar to those on which Figure 26 is based, were generated for the other four existing vehicle designs considered in the study and were stored along with the M113 data. From all these data, each unit area type which permitted Go was extracted and examined for "margin of Go", defined as a normalized excess of available over required vehicle performance. For example, if the critical terrain feature is simply grade, it is compared with a vehicle gradeability according to the following formula:

$$\text{MARGIN OF GO} = \frac{\text{GRADEABILITY} - \text{GRADE}}{\text{GRADEABILITY}}$$

Then, for each test (A through O for areal, R through Z for lineal), the characteristics of the 15\* unit terrains most marginal for vehicle traversal

---

\*Fifteen was chosen arbitrarily as a reasonable number for present purposes; five were based on terrain conditions at the maximum severity end of the ranges, five on minimum severity and five at midrange.

were identified as points establishing the performance envelope, but the number of these points was still large (e.g., for areal, 15 tests x 15 points per test - 225 points). Based on engineering experience, a judicious final selection reduced this number to 18 points upon which to base performance specifications for each of the existing vehicle designs. Coordinates of these points are listed in the first five columns of Table 6. A similar table for hydrologic features may be found in Reference 38.

Having completed this analysis, the results can now be used by actually testing a vehicle against terrain having parameter values nearly equal to the coordinates of the key points. If the vehicle performs satisfactorily in these severe test terrains, it can be assumed that the vehicle would perform satisfactorily under the less severe conditions represented by points farther within the envelope. The important gain brought about by this approach is to limit the tests required to a practical number and still retain sufficiently complete coverage of the multiple of environmental combinations in which the vehicle will be required to operate. Another important use of such data for existing vehicles is in the design and test of companion vehicles which should have similar performance in the same type of terrain.

An example is now presented to show how some of the techniques and data developed as described above can be applied to design of a vehicle to improve its performance in the specified terrain of the study region. The performance data for the five vehicles already discussed were put to use to suggest those design improvements required to substantially increase a vehicle's mobility. The M113 was chosen to illustrate this process, and after a number of iterations (on paper) it evolved into a narrower articulated vehicle with increased ground contact area and clearance. Design changes were constrained such that gross features of the vehicle (e.g., weight, payload, cargo space) did not undergo large changes. Nonetheless, it is emphasized that the modified vehicle is strictly a hypothetical paper design--no contention whatever is made that this design is ready to build.

**Table 6**  
**SUMMARY OF MOST CRITICAL AREAL TERRAIN CONFIGURATIONS**  
**FOR VARIOUS LEVELS OF GO**

Vehicle			M41	GOER	VNIA	M113	WEASEL	HV
Percent No-Go Area (uphill, midrange)			64.5	52.0	28.8	54.6	33.9	23.1
<b>Test Criteria</b>								
Long Grade	Slope	%	44	44	44	44	44	57
Basic Soils Trafficability	Soil RCI	psi	60	25	25	42.5	25	25
Obstacle Angle of Approach	Approach Angle	deg	7			7		22
Single Tree to be Overridden	1 Slope = 0							
	Hard Surface							
	Diameter	in	10	10	10	10	10	10
	2 Slope	%	44	24	24	24	32	11
	Soil RCI	psi	150	150	150	200	115	115
	Soil Cohesion	psi	0.5	0.5	0.5	1.0	0.5	0.5
	Soil Friction		0.57	0.57	0.57	0.83	0.41	0.41
	Diameter	in	6	10	6	6	6	10
	3 Slope	%	1	0	0	1	2	2
	Soil RCI	psi	80	25	25	80	60	60
	Soil Cohesion	psi	0.5	0.0	0.0	0.5	0.0	0.0
	Soil Friction		0.26	0.17	0.26	0.17	0.17	0.17
	Diameter	in	6	6	6	6	6	6
Non-Pushable Trees	Mean Spacing	ft	20	20	30	20	10	10
Multiple Trees to be Overridden	1 Slope = 0							
	Hard Surface							
	Diameter	in	5	5	5	5	5	5
	Mean Spacing	ft	3	3	3	5	7	3
	2 Slope	%	24	24	32	44	44	44
	Soil RCI	psi	150	150	200	150	150	150
	Soil Cohesion	psi	0.5	0.5	1.0	0.5	0.5	0.5
	Soil Friction		0.57	0.57	0.83	0.57	0.57	0.57
	Diameter	in	5	5	5	5	5	5
	Mean Spacing	ft	3	3	5	7	3	3
	3 Slope	%	5	5	1	1	1	1
	Soil RCI	psi	150	96.2	96.2	150	150	150
	Soil Cohesion	psi	0.5	0.5	0.5	0.5	0.5	0.5
	Soil Friction		0.31	0.41	0.41	0.08	0.08	0.08
	Diameter	in	5	5	5	5	5	5
	Mean Spacing	ft	3	3	3	7	7	3
Obstacle Clearance	1 SH	in	30	30	18			
	AA	deg	18	18	18			
	2 SH	in						
	AA	deg						
Slope and Soil	1 Slope	%	44	44	44	44	44	57
	Soil RCI	psi	150	150	150	150	150	200
	Soil Cohesion	psi	0.5	0.5	0.5	0.5	0.5	1.0
	Soil Friction		0.57	0.57	0.57	0.57	0.57	0.83
	2 Slope	%	11	7	7	7	7	7
	Soil RCI	psi	96.2	62.5	62.5	62.5	62.5	62.5
	Soil Cohesion	psi	0.5	0.0	0.0	0.0	0.0	0.0
	Soil Friction		0.41	0.26	0.26	0.26	0.26	0.26
Obstacle Negotiation Up Slope	1 Slope	%	44	24	32	32	44	57
	Soil RCI	psi	150	150	200	200	150	200
	Soil Cohesion	psi	0.5	0.5	1.0	0.0	0.5	1.0
	Soil Friction		0.57	0.57	0.83	0.83	0.57	0.83
	SH	in	2	14	10	10	7	10
	AA	deg	7	22	30	30	42	30
	2 Slope	%	1	7	2	0	0	0
	Soil RCI	psi	80	62.5	100	60	60	60
	Soil Cohesion	psi	0.5	0.0	0.0	1.0	1.0	1.0
	Soil Friction		0.26	0.26	0.17	0.17	0.17	0.17
	SH	in	2	48	4	10	18	18
	AA	deg	7	15	15	55	55	55
	3 Slope	%	5	5	5	5	24	24
	Soil RCI	psi	96.2	96.2	96.2	115	150	150
	Soil Cohesion	psi	0.5	0.5	0.5	0.5	0.5	0.5
	Soil Friction		0.41	0.41	0.41	0.41	0.57	0.57
	SH	in	39	39	39	7	14	14
	AA	deg	7	7	7	22	22	22
	4 Slope	%	1	1	0	0	0	0
	Soil RCI	psi	80	80	60	60	60	60
	Soil Cohesion	psi	0.5	0.5	1.0	1.0	1.0	1.0
	Soil Friction		0.26	0.26	0.17	0.17	0.17	0.17
	SH	in	24	24	18	18	18	18
	AA	deg	7	7	30	55	55	55

The expansion of the performance boundary is illustrated by the tabulation of the new vehicle's capabilities in the sixth column of Table 6 (labeled "HIV"). Figure 27 shows the Go/No-Go map for this hypothetical vehicle. It is noted that, in addition to considerable increase in go area, the areal No-Go that remains is almost entirely the result of severe combinations of impedances (Tests L, M, N and O listed in Table 4). Thus, in the context that No-Go was interpreted above, the hypothetical vehicle could probably negotiate almost the entire study region; it still, however, could not negotiate most of the streams.

In conclusion, the significance of being able to delineate testable performance specifications of the type listed in Table 6 is emphasized. These data define a limited number of terrain conditions, representing general levels of performance, against which a vehicle can be tested. Test environments can actually be selected or synthesized from the data for this purpose.

### 3.6.2 Mobility Study of Four Vehicles

The objective of this study was to provide insight into the relationships which exist between mobility requirements and vehicle research and development testing and which may play an important role in the advancement of off-road mobility.

A case study<sup>57</sup> was made of the development and operational history of four off-road vehicles currently in the U.S. Army inventory. These vehicles were the M113 Full Tracked Armored Personnel Carrier; the M114 Full Tracked Command and Reconnaissance Vehicle; the M520E1 8-ton, 4x4 Cargo Truck; and the M561, 1-1/4 ton, 6x6 Cargo Truck. Of specific interest were those historical aspects which influence the vehicle's ability to traverse terrain in various environments. Documents relating to concept development, requirements, tests and evaluations, operational experience and program management for the four candidate vehicles were reviewed and analyzed to provide an

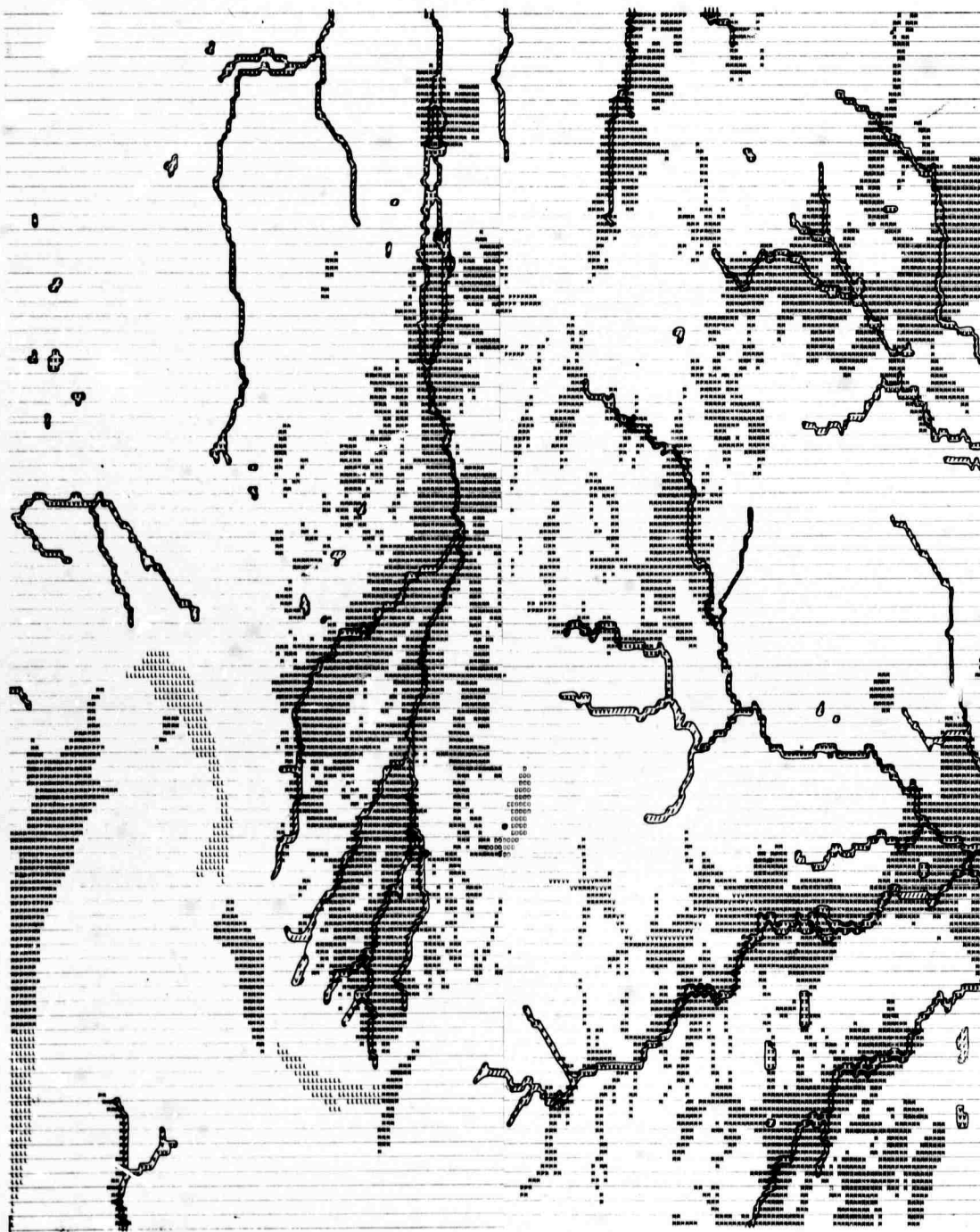

Figure 27 GO/NO-GO MAP FOR HYPOTHETICAL VEHICLE

an indication of how effectively the guidance information contained in these documents was used in appropriate phases of the development cycle.

In the course of this review of the evolution of the candidate vehicles problem areas were isolated, which, in the past, did not receive sufficient attention and which have affected vehicle development. Moreover, a growing awareness of these problems was observed, demonstrated by the improvement in the relationship between requirements documentation and guidance for test and evaluation.

For example, consider a comparison of the mobility statements with tests actually performed during the early stages of vehicle development for three of the candidate vehicles. Table 7 taken from Reference 7 and modified, is a condensed and general summation of some of the results of the present investigation and from this, we wish to draw attention to certain relationships. The first column lists the general performance requirements stated as objectives in the guidance documents. Column 2 lists off-road mobility operational factors influenced by environment and relatable to the general performance objectives. This is an arbitrary relationship based on recognized factors influencing performance. Columns 3, 4, 5 and 6 itemize implicit and explicit statements of requirements as related to Columns 1 and 2. The letter "R" refers to the descriptors stated or implied in requirements documents, and the letter "T" denotes actual tests accomplished in the measurement of performance within the specified environment.

It will be noted that the Military Characteristics (MC's) used in the development of the M113 and M114 did not include a breakout of each environmental factor, and that the specific terrain or climatic factor can only be implied by referring to general operational requirements. The number of T's included represent early testing results and do not include, therefore, comparative evaluations of vehicles in potential combat environments; (e.g. MUDLARK).<sup>60</sup> From the mid 1950's to the present, there appears to be a greater refinement of the descriptors for environment and at the same time,

**Table 7**  
**COMPARISON OF MOBILITY REQUIREMENT STATEMENTS**  
**WITH TESTS PERFORMED**

PERFORMANCE REQUIREMENT	OFF-ROAD MOBILITY OPERATIONAL FACTORS INFLUENCED BY ENVIRONMENT	M113	M114	M520		
CROSS COUNTRY MOVEMENT	TRENCH	↑ ↓	↑ ↓	R <sup>3</sup> T		
	SNOW			R <sup>2</sup> T		
	MUD			T		
	SAND			T		
	SWAMP/ MARSH			T		
	VEGETATION			T		
	VERTICAL OBSTACLE			R <sup>1</sup> IMPLIED R <sup>2</sup> T	R <sup>1</sup> IMPLIED R <sup>2</sup> T	R <sup>3</sup> T
	LONGITUDINAL SLOPE			R <sup>2</sup> T	R <sup>2</sup> T	R <sup>3</sup> T
	SIDE SLOPE			R <sup>2</sup> T	R <sup>2</sup> T	T
	AVERAGE ROLLING TERRAIN			T	T	T
	MUSKEG					R <sup>3</sup>
STONEY DESERT			R <sup>3</sup>			
TRAIL BREAKING			R <sup>3</sup>			
WATER CROSSING	INLAND WATER SWIM	R IMPLIED R <sup>2</sup> T	R IMPLIED R <sup>2</sup> T	R T		
	INLAND WATER ENTER	↓	↓	R <sup>3</sup> T		
	INLAND WATER EXIT			T		
	SWIMMING - LOTS			T		
	SHALLOW/DEEP WATER FORD			T		
				R <sup>3</sup> T		
MANEUVERABILITY (OFF-ROAD)	EFFECTS OF CLIMATOLOGICAL PARAMETERS AND TERRAIN FEATURE:	↑ ↓	↑ ↓	↑ ↓		
	SPEED				R <sup>1</sup> IMPLIED	T
	ACCELERATION					T
	TURNING					T
	BRAKING					T
			R IMPLIED	T		
				T		
R = DESCRIPTORS OF THE ENVIRONMENT IN THE REQUIREMENT DOCUMENTS. T = EVALUATIONS MADE BY TEST AGAINST THESE STATEMENTS OF ENVIRONMENT		NOTE ① ORIGINAL MC RELATES REQUIRED PERFORMANCE TO OFF-ROAD MOBILITY OF M59 REF OTCM 36049	NOTE ② SPECIFIED BY TC'S OF 1963 M59 NOT MENTIONED	NOTE ③ OFF-ROAD MOBILITY EQUAL TO TACTICAL UNITS BEING SUPPORTED REF OTCM 37462		

more quantitative measures and criteria are given. Thus, it may be inferred that a greater effort is being made to evaluate the vehicle capability in more specific terms than was possible in the mid 50's when criterion statements used such terms as "superior" and "better than".

It can be observed from Table 7 that in the guidance documents relating to M520 there are a high percentage of Requirement Statements (R) specifying descriptors of physical environment in which the vehicle is to be operated. There has been a major effort in the past few years to improve the flow of information and to underscore the importance of phasing of the separate elements of R&D management. For example, AR705-5, which is Army Guidance for Research and Development of Materiel, establishes responsibility, policy and procedures for the conduct of research and development. This document provides guidance for the development of materiel which satisfies the qualitative materiel objectives stated in the CDOG. Another document issued by the Army Materiel Command (AMC) establishes policies and responsibilities for configuration management for materiel and equipment for which AMC has responsibility. This document is titled Army Programs -- Configuration Management, AMCR 11-26. These guidance documents state: that the environment is to be specified in which the materiel is to be operated; modes of operation; and methods of test and evaluation. For example, the plans for test, including environmental specification must be in the hands of the developer early in the development of the program.

The important general conclusions for improving vehicle mobility drawn from the various areas of requirements, program management, testing and evaluation, training and operations are listed below.

1. Requirements and other guidance documents would be of more value to those organizations concerned with research and development of vehicles if they included more specific state-

ments of mobility requirements and descriptions of operational environments. This would permit less freedom of interpretation of Department of Army guidance by vehicle developers, manufacturers and test evaluation organizations.

- a. The degree of mobility a vehicle is expected to obtain is established in the requirements documents. It is imperative, therefore, that the measures and criteria required be clearly defined for typical environmental factors such as soil, climatic and meteorological conditions, and that the operational concept include detailed environmental descriptors. This information is vital for design of tests and evaluation of results.
  - b. Performance requirements should be related to standard environmental bases, particularly when two classes of vehicles are to be compared.
2. Test and evaluation results would be of more value in vehicle mobility evaluation if complete descriptions of the test environment were reported.
  3. More emphasis is needed on the analysis of human factors data (from both test and combat) pertinent to vehicle operations in extreme environments as an aid in:
    - a. Selection of personnel for operator training,
    - b. Developing advanced training methods to exploit operator skill in off-road mobility,

- c. Calibrating operator performance between test range and combat areas, and
- d. Defining improvements needed on vehicle/operator interface to enhance mobility.

It should be noted that some of the above conclusions are similar to those resulting from the Full Scale Mobility Test and Evaluation Practices study summarized in Section 3.2.3 of this report.



#### 4. RECOMMENDATIONS FOR FUTURE OFF-ROAD MOBILITY STUDIES

The ORMR program has been directed at identifying the dominant technical uncertainties in the off-road mobility process, then engaging in research tasks aimed at reducing the uncertainties to acceptable levels to permit predicting off-road mobility adequately.

As was pointed out in the Introduction and the General Discussion (Section 3.1), this approach stemmed from an exhaustive survey of pertinent mobility literature followed by the careful definition and structuring of a long-term plan for off-road mobility research. Accordingly, the rationale for CAL's ORMR program has been that improved knowledge gained from further research will enable greater precision in vehicle selection, allocation and design, and will indicate the preferred paths for significant performance improvement.

Consistent with this rationale, several research tasks (all of them technical) have been undertaken since the ORMR research investigations started in February of 1967. The research has been summarized in the previous sections of this report. Most of the tasks, it will be noted, are not yet completed. However, since they continue to be of significant importance to the off-road mobility knowledge base, we firmly believe that these tasks should be continued. We particularly emphasize the importance of the following:

Vehicle Dynamics Model: The Vehicle Dynamics Model which currently accommodates wheeled vehicles moving in a straight line over smooth undulating terrain and hard surface obstacles should be extended to include steering and also to operate with soft and slippery soil. Further the capability needs to be introduced into the model to handle tracked vehicles on both hard and soft soil. It is important to examine the correspondence between the factors the model predicts that significantly affect mobility parameters, (e.g. drawbar pull,

slope climbing, Go/No-Go) and those carefully measured in well-defined experiments, to get at the problem of large disparities between prediction and test. The validation program started on the wheeled model should be completed and extended to the tracked model.

When its applicability and limitations are known, the model, in addition to providing a systematic framework for identifying and examining the factors influencing mobility, will provide an important evaluation tool useful to vehicle specifiers, designers, allocators and users.

Bounding of Fundamental Traction Modes: The development of working theories for each of the basic modes of achieving traction is recommended, to permit the determination of limiting values on the performance of "unconventional" ground contact vehicles.

Visioplasticity Experiments and Analysis: The research on the application of the visioplasticity method to studies of rigid wheels traversing soft soil has shown the technique to have considerable potential. It is recommended that this research be continued and extended to flexible wheels and to three-dimensional situations. Further we recommend that visioplasticity experiments be conducted on soil measuring instruments that involve indenting the soil, to determine the relationship between the stress-strain properties of the soil and the indentation force-displacement measurements, and to provide an indication of the importance of the surface properties and geometry of the measuring instrument.

Computer Mapping Techniques: Extension of the field mapping techniques developed on the ORMR program is also recommended. This would involve the extension of mapping by computer into the area of route selection. Also recommended is refining of computer techniques to streamline and standardize current map-producing programs and to create more efficient techniques for printing out computer maps.

Structuring Environmental Description: A rational concept has been formulated, in the ORMR program, for structuring environmental description in vehicular terms.<sup>6</sup> The concept employs set theory and the theory of ordered systems in classifying the environment in a finite number of "test environment categories." The development of this concept should be pursued. A substantial volume of the required information and data is available in standard geological, geographic, forestry and hydrologic references.

Supplementing the above should be investigations of inferential relationships among environmental factors that exist as a result of geologic, geomorphologic and cultural influences. Such relationships will aid in defining joint occurrences of levels of environmental factors.

Driving Simulator Development and Application: We continue to view laboratory simulation of off-road driving conditions as an essential tool for evaluating the human operator's influence on off-road mobility. When coupled with the Vehicle Dynamics Model, a driving simulator can provide information relating to basic driver-limited vehicle performance functions, e.g. speed limitations due to ride, degraded visibility and finite reaction times. Thus we recommend continued development of laboratory means for feeding back vehicle response to a driver to provide him visual and motion cues. Figure 24 in Section 3.5.2 is a conceptual sketch of what is envisioned.

Implementation of these technological improvements in off-road mobility knowledge which we have identified and suggested is recognized as a costly undertaking and the question arises: what in the practical sense constitutes adequate prediction of off-road mobility?

Our discussions with professionals representing both the suppliers and users of off-road vehicles and technology have shown a wide spread of opinion concerning the ultimate value of a better understanding of the physical processes involved and reduction of the technological uncertainties.

Accompanying these basic differences of opinion is the question of where better predictive methods, both of content and form, would specifically be applied to improve the decision-making process.

It is important that the differences of opinion be replaced, as far as possible, by fact if the potential role of improved off-road vehicle mobility is to be reasonably evaluated -- rationale must be established relating how and why the research will have an operational payoff. There is a need to relate the technology of off-road mobility to the needs of the decision-makers. There is also a need to examine the ground vehicles rightful place among all military transportation modes. Therefore, we recommend that concurrently with the technical research, a systems research investigation also be undertaken. This investigation should determine how the technology of off-road mobility may be appropriately introduced in the evaluations of selectors and decision-makers to reveal the requirements and opportunities for, and the importance and urgency of potential technical improvements.

The systems research investigation should be aimed at assisting the Department of Defense at both the Office of Secretary of Defense and service levels. This can be accomplished by combining experienced professional military judgment with operations analysis and mobility research to develop promising ways of addressing technical knowledge to problems of resource allocation, to try these in the context of real problems, refine and expand them and converge on meaningful information and methods for improving off-road mobility evaluation.

## 5. REFERENCES

1. Bartlett, G.E., Kaufman, S., McAdams, H.T. and Smith, R.L. (co-editors), "Survey and Program Definition for Off-Road Mobility Research," First Semiannual Technical Report, Technical Report No. VJ-2230-G-1, Cornell Aeronautical Laboratory, Inc., March 1967.
2. Yong, R.N, Boyd, C.W. and Webb, G.L., "Experimental Study of Behavior of Sand Under Moving Rigid Wheels," Soil Mechanics Series Report 20, McGill University, Montreal, Canada, August 1967.
3. Brandt, G.H., "Research on Soil Stabilization," (U), Final Report, Dow Report S-2-1869, February 1968, SECRET.
4. Bartlett, G.E., Kaufman, S. and Deutschman, J.N. (co-editors), "Off-Road Mobility Research," Second Semiannual Technical Report, Technical Report No. VJ-2330-G-2, Cornell Aeronautical Laboratory Inc., September 1967.
5. Nuttall, C.J. Jr., Grenke, W.C. and Smith, R.L., "On Testable Performance Specifications for Terrain Adapted Vehicles," Proceedings of the Off-Road Mobility Research Symposium, Washington, D.C., June 1968.
6. Quirk, J.H., Leonard, R.P., Coakley, R.W. and McAdams, H.T., "A Taxonomical Approach to Off-Road Mobility Testing," Proceedings of the Off-Road Mobility Research Symposium, Washington, D.C., June 1968.
7. Sexton, G.S., and Andrews, J.N. Jr., "Relationships of Mobility Requirements and Testing," Proceedings of the Off-Road Mobility Research Symposium, Washington, D.C., June 1968.
8. Bartlett, G.E., Belsdorf, M.R., Deutschman, J.N. and Smith, R.L., "On the Prediction of Off-Road Vehicle System Mobility," SAE Paper 690150, Society of Automotive Engineering Congress, Detroit, Michigan, January 13-17, 1969.
9. McHenry, R.R., Segal, D.J. and DeLeys, N.G., "Computer Simulation of Single Vehicle Accidents," Stapp Car Crash Conference, Anaheim, California, October 1967, New York: Society of Automotive Engineers, Inc., 1967.
10. Heal, S., and Cicillini, C., Micro Terrain Profiles, U. S. Army Tank-Automotive Center, ATAC Report RRC-9, August 1964.

11. Pavlics, F., "Locomotive Energy Requirements For Lunar Surface Vehicles," Paper No. 660149, Society of Automotive Engineering Congress, Detroit, Michigan, January 10-14, 1966.
12. Walls, J.H., Houbolt, J.O., and Press, H., "Some Measurements and Power Spectra of Runway Roughness," NACA Technical Note 3305, November 1954.
13. Kozin, F., Cote, L.J., and Bogdanoff, J.L., "Statistical Studies of Stable Ground Roughness," Land Locomotion Laboratory, U.S. Army Tank-Automotive Center, Report No. 8391, November 1963.
14. Peuzner, J.M., and Tichonov, A.A., "Untersuchungen statistischer Eigenschaften des Mikroprofils wesentlicher Typen von Autostraßen. Automobilnaja promyslennost 1964, No. 1, S. 15/18.
15. Albat, E., Über Straßenschonung und Fahrsicherheit bei Schwerlastfahrzeugen mit Doppelachsen. Diss. TH Braunschweig, 1964.
16. Bekker, M.G., "Off-The-Road Locomotion," The University of Michigan Press, Ann Arbor, Michigan, 1960.
17. Janosi, Z.J. and Hanamoto, B., "The Analytical Determination of Drawbar Pull as a Function of Slip for Tracked Vehicles in Deformable Soils, Proceedings of the First International Conference on Mechanics of Soil-Vehicle Systems, Torino, Italy, Paper No. 44, 1962.
18. Pleuthner, R.L., "A Critique on the Performance of Off-Road Vehicles - Full-Scale Test Results and Prediction Method Evaluation," Cornell Aeronautical Laboratory, Inc., Technical Memorandum No. VJ-2330-G-54, January 1969.
19. Czako, T.F., and Janosi, Z.J., "State of the Art of Vehicle Performance Prediction," U.S. Army Tank-Automotive Center, Technical Report No. 9560, Research Report No. 6, November 1966.
20. Harrison, W.L., Jr., "Analytical Prediction of Performance of Full Size and Small Scale Model Vehicles," Proceedings of the First International Conference on Mechanics of Soil-Vehicle Systems, Torino, Italy, Paper No. 43, 1962.
21. Janosi, Z., "An Analysis of Pneumatic Tire Performance on Deformable Soils," Proceedings of the First International Conference on Mechanics of Soil-Vehicle Systems, Torino, Italy, Paper No. 45, 1962.
22. Janosi, Z. and Hanamoto, B., "An Analytical Determination of Drawbar Pull as a Function of Slip for Tracked Vehicles in Deformable Soils," Proceedings of the First International Conference on Mechanics of Soil-Vehicle Systems, Torino, Italy, Paper No. 44, 1962.

23. Anonymous, Trafficability of Soils; A Summary of Trafficability Studies Through 1955, "Technical Memorandum No. 3-240, Fourteenth Supplement, U.S. Army Engineer Waterways Experiment Station, CE, December 1956.
24. Liston, R.A., et al, "Mobility Environmental Research Study, Mobility Testing Procedures, Army Tank-Automotive Center, February 1966.
25. Nuttall, C.J., Jr., Wilson, C.W., and Werner, R.A., "One-Pass Performance of Vehicles on Fine-Grained Soils, "Contract Report No. 3-152, conducted by Wilson, Nuttall, Raimond Engineers. Inc., for U.S. Army Engineer Waterways Experiment Station, CE, July 1966.
26. Perloff, W.H., "Mobility of Tracked Vehicles on Soft Soils," School of Civil Engineering, Purdue University, also The Proceedings of the Second International Conference of the International Society for Terrain-Vehicle Systems, Canada, August 1966.
27. Reece, A.R., "Principles of Soil-Vehicle Mechanics," Automotive Division, the Institute of Mechanical Engineers, November 1965.
28. Onafeko, O, and Reece, A.R., "Soil Stresses and Deformation Beneath Rigid Wheels," Journal of Terramechanics, Vol. 4, No. 1, 1967.
29. Wong, Jo-Yung, and Reece, A.R., "Prediction of Rigid Wheel Performance Based on the Analysis of Soil-Wheel Stresses, Part I, Performance of Driven Rigid Wheels, Journal of Terramechanics, Vol. 4, No. 1, 1967.
30. Wong, Jo-Yung, and Reece, A.R., "Prediction of Rigid Wheel Performance Based on the Analysis of Soil-Wheel Stresses, Part II, Performance of Towed Rigid Wheels, Journal of Terramechanics, Vol. 4, No. 2, 1967.
31. Anonymous, "Off-Road Vehicle Mobility Evaluation," SAE Recommended Practice Handbook Supplement, SAE J939, March 1967.
32. Anonymous, "Project Wheeltrack -- A Comparative Operational Mobility Evaluation," Vols. I-III, USATRANSBP, Army Tank-Automotive Center and Waterways Experiment Station, TCB-61-175-OF, 1963.
33. Haley, Peter W., "Mobility Environmental Study One-Pass Program," Army Tank-Automotive Center, ARPA Order No. 400, January 1965.
34. Liston, R.A., and Hanamoto, B., "The Drawbar Pull-Weight Ratio as a Measure of Vehicle Performance," Paper No. 670170, Society of Automotive Engineering Congress, Detroit, Michigan, January 1967.

35. Hegedus, E., "A Simplified Method of the Determination of Bulldozing Resistance," Land Locomotion Report No. 61, Army Tank-Automotive Center, Detroit Arsenal, 1960.
36. Liston, R.A., "Correlation Between Predicted and Actual Off-Road Vehicle Performance," Paper No. 670170, Society of Automotive Engineering Congress, Detroit, Michigan, January 1967.
37. Anonymous, "Research and Development of Materials," Army R&D, AR705-5, June 1966.
38. Nuttall, C.J. Jr., and Grenke, W.C., "A First Cut at Developing Testable Off-Road Performance Specifications for Vehicles Adapted to Specific Terrains," WNRE, Inc., Report No. 169-1, July 1968.
39. Anonymous, "Mobility Environmental Research Study; A Quantitative Method for Describing Terrain for Ground Mobility; Terrain Factor-Family Maps of Selected Areas," Technical Report No. 3-726, Vol. III, U.S. Army Engineer Waterways Experiment Station, CE, June 1966.
40. Anonymous, "Report of the Working Group on Land Classification and Data Storage," Military Engineering Experimental Establishment, MEXE Report No. 940, Christchurch, England, 1966.
41. Mather, J.W. (ed.), "Average Climatic Water Balance of the Continents," Laboratory of Climatology, Centerton, N.J., 1957.
42. U.S. Army Corps of Engineers, Waterways Experiment Station, Private Communication, 1967.
43. Anonymous, "Trafficability of Soils; Soil Classification," Technical Memorandum No. 3-240, Sixteenth Supplement, U.S. Army Engineer Waterways Experiment Station, CE, August 1961.
44. Anonymous, "Report of Conference on Soil Trafficability Prediction," U.S. Army Engineer Waterways Experiment Station, CE, April 1967.
45. McAdams, H.T., "Computer Mapping and Data Presentation," Cornell Aeronautical Laboratory, Inc., Technical Memorandum No. VJ-2330-G-55, January 1969.
46. Anonymous, "The Unified Soil Classification System", Technical Memorandum No. 3-357, U.S. Army Engineer Waterways Experiment Station, CE, April 1960.
  - Appendix A: "Characteristics of Soil Groups Pertaining to Embankments and Foundations"
  - Appendix B: "Characteristics of Soil Groups Pertaining to Roads and Airfields"

47. Miller, P.M., "A Report on the Application of the Visioplasticity Method to Soft Soil Mobility Problems," Cornell Aeronautical Laboratory, Inc., Technical Memorandum VJ-2330-G-53, September 1968.
48. Yong, R.N., Japp, R.D. and Windisch, S.J., "Soil Bin Studies," McGill University Report to CAL, September 1968.
49. Henkel, D.J., Esrig, M.I., Steinbach, J and Yudhbir, "Some Aspects of Soil Mechanics in Relation to Vehicle Mobility," Soil Engineering Series, Research Report No. 5, Cornell University, Ithaca, New York February 1968.
50. Henkel, D.J., Esrig, M.I., Steinbach, J. and Yudhbir, "The Use of Consolidated and Artificial Soils for the Study of Vehicle Mobility," Soil Engineering Series, Research Report No. 8, Cornell University, Ithaca, New York, July 1968.
51. Dagan, G., and Tullin, M.P., "A Study of the Steady Flow of a Rigid-Plastic Clay Beneath a Driven Rigid Wheel," Hydronautics, Inc., Technical Report No. 823-1, August 1968.
52. Leitch, H.C. and Yong, R.N., "The Rate Dependent Mechanism of Shear Failure in Clay Soils," McGill University, Soil Mechanics Series No. 21, August 1967.
53. Sloane, R.L. and Nowatzki, E.A., "Electron-Optical Study of Fabric Changes Accompanying Shear in Kaolin Clay," Third PanAmerican Conference on Soil Mechanics and Foundation Engineering, 1967.
54. Martin, R.T., "Research on the Physical Properties of Marine Soil," MIT, Dept. of Civil and Sanitary Engineering, Publ. No. 127, 1962.
55. Yong, R.N. and Japp, R.D., "Soil Water Relationships and Their Engineering Applications," McGill University Report to CAL, September 1968.
56. McAdams, H.T., "Computer Techniques of Environmental Mapping," CIRADS III Proceedings, Vol. 1, Meeting of October 15-17 1968, Columbus, Ohio.
57. Andrews, J.N. Jr., and Sexton, G.S., "A Mobility Study of Four Vehicles," Cornell Aeronautical Laboratory, Inc. Technical Memorandum No. VJ-2330-G-52, August 1968.
58. Nuttall, C.J., Jr., "Ground Crawling, 1966; State-of-the-Art of Designing Off-Road Vehicles," Contract Report No. 3-162, U.S. Army Engineer Waterways Experiment Station, CE, May 1967.

59. "Mobility Environmental Research Study: A Quantitative Method for Describing Terrain for Ground Mobility," (8 vols.), U.S. Army Engineer Waterways Experiment Station.

Vol. I	- Summary	Jan. 1968
II	- Surface Composition	Jan. 1968
III	- Surface Geometry	Nov. 1967
IV	- Vegetation	Nov. 1967
V	- Hydrologic Geometry	Nov. 1967
VI	- Selected Air-Photo Patterns of Terrain Features	June 1966
VII	- Development of Factor-Complex Maps for Ground Mobility	June 1966
VIII	- Terrain Factor-Family Maps	June 1966

60. "MUDLARK: Tests of the FV432 Stalwart, M113-1/2, M551 and FV437 in Thailand," Joint Thai-U.S. Military Research and Development Center, 67-016, April 1967.

UNCLASSIFIED

Security Classification

## DOCUMENT CONTROL DATA - R &amp; D

(Security classification of title, body of abstract and indexing annotation must be entered when the overall report is classified)

1. ORIGINATING ACTIVITY (Corporate author) Cornell Aeronautical Laboratory, Inc. Buffalo, New York		2a. REPORT SECURITY CLASSIFICATION	
		2b. GROUP	
3. REPORT TITLE Summary Report on Off-Road Mobility Research			
4. DESCRIPTIVE NOTES (Type of report and Inclusive dates) Technical Report (2 Vols.) - Summarizing the studies performed between August 1966 and Oct. 1968 with emphasis on period Sept. 1967 to October 1968.			
5. AUTHOR(S) (First name, middle initial, last name) Co-editors George E. Bartlett Jerome N. Deutschman			
6. REPORT DATE November 1968	7a. TOTAL NO. OF PAGES	7b. NO. OF REFS	
8a. CONTRACT OR GRANT NO DAHC04 67 C 0005	9a. ORIGINATOR'S REPORT NUMBER(S) CAL Report No. VJ-2330-G-3		
b. PROJECT NO. ARPA Order No. 841 dated 7 May 1966	9b. OTHER REPORT NO(S) (Any other numbers that may be assigned this report)		
c.			
d.			
10. DISTRIBUTION STATEMENT Distribution of this document is unlimited.			
11. SUPPLEMENTARY NOTES Contracting Agency - U.S. Army Research Office-Durham		12. SPONSORING MILITARY ACTIVITY ARPA	
13. ABSTRACT A summary of research and engineering studies conducted on a long-range program of off-road mobility research is presented in Vol. I of this two-volume report. These studies, some of which are only partially completed, are directed at providing technical knowledge which is required to match off-road vehicles with military mobility requirements.  A hybrid computer model is described which will permit predicting vehicle dynamics performance of simulated vehicles traversing a broad spectrum of off-road situations. A critique of existing soil trafficability theories is made based on a review of the literature which treats the comparison of vehicle performance prediction with experimental results. Analytical and experimental studies of the velocity field and soil fabric in clay soil exposed to dynamic loads are summarized. A general method is discussed for processing mobility related environmental information and for mapping vehicle performance by computer methods. A concept is introduced for testing vehicles in relation to the total environment in order to define the vehicle performance envelope.  Also a method is introduced for displaying potential vehicle performance in selected geographic areas and for producing "testable" specifications for off-road vehicles. Engineering studies of an off-road driving simulator for synthesizing dynamic visual displays and vehicle motion in the laboratory are reviewed.  Recommendations pertaining to future off-road mobility research and engineering studies are presented.			

DD FORM 1473  
1 NOV 65

engineering studies are presented.

UNCLASSIFIED

Security Classification

Volume II contains Appendices that complement the material presented in Volume I.

**UNCLASSIFIED**

Security Classification

14. KEY WORDS	LINK A		LINK B		LINK C	
	ROLE	WT	ROLE	WT	ROLE	WT
Off-Road Mobility Mobility Systems Studies Vehicle-Terrain Interaction Human Factors Environment Soil Mechanics						

**UNCLASSIFIED**

Security Classification