

MISC

AMRL-TR-68-145

AD690140

Citation



## ULTRAVIOLET OXYGEN SENSOR

A. KAPLAN

C. JURGENS

K. YU

*Beckman Instruments, Inc.*

JANUARY 1969

This document has been approved for public  
release and sale; its distribution is unlimited.

20060711094

STINFO COPY

AEROSPACE MEDICAL RESEARCH LABORATORY  
AEROSPACE MEDICAL DIVISION  
AIR FORCE SYSTEMS COMMAND  
WRIGHT-PATTERSON AIR FORCE BASE, OHIO

## NOTICES

When US Government drawings, specifications, or other data are used for any purpose other than a definitely related Government procurement operation, the Government thereby incurs no responsibility nor any obligation whatsoever, and the fact that the Government may have formulated, furnished, or in any way supplied the said drawings, specifications, or other data, is not to be regarded by implication or otherwise, as in any manner licensing the holder or any other person or corporation, or conveying any rights or permission to manufacture, use, or sell any patented invention that may in any way be related thereto.

Federal Government agencies and their contractors registered with Defense Documentation Center (DDC) should direct requests for copies of this report to:

DDC  
Cameron Station  
Alexandria, Virginia 22314

Non-DDC users may purchase copies of this report from:

Chief, Storage and Dissemination Section  
Clearinghouse for Federal Scientific & Technical Information (CFSTI)  
Sills Building  
5285 Port Royal Road  
Springfield, Virginia 22151

Organizations and individuals receiving reports via the Aerospace Medical Research Laboratories' automatic mailing lists should submit the addressograph plate stamp on the report envelope or refer to the code number when corresponding about change of address or cancellation.

Do not return this copy. Retain or destroy.

AMRL-TR-68-145

## **ULTRAVIOLET OXYGEN SENSOR**

*A. KAPLAN*

*C. JURGENS*

*K. YU*

This document has been approved for public  
release and sale; its distribution is unlimited.

## FOREWORD

The Ultraviolet Oxygen Sensor has been developed under Contract No. F33615-67-C-1775 by Beckman Instruments, Inc., Advanced Technology Operations, 2500 Harbor Boulevard, Fullerton, California, as Beckman Job No. 2499. The contract monitor was Ints Kaleps, Biotechnology Branch, Life Support Division of the Biomedical Laboratory, Aerospace Medical Research Laboratories.\* The research was performed in support of Project 6373, "Equipment for Life Support in Aerospace," Task 637302, "Respiratory Support Equipment," Work Unit No. 637302044, "Development of a Quantitative Oxygen Sensor Utilizing the Ultraviolet Absorption of Oxygen." This research began in June 1967 and was completed in July 1968.

This technical report has been reviewed and is approved.

C. H. KRATOCHVIL, Colonel, USAF, MC  
Commander  
Aerospace Medical Research Laboratory

---

\*In December 1968, the Biotechnology Branch, Life Support Division, and Biomedical Laboratory were abolished. The Laboratories were redesignated Aerospace Medical Research Laboratory.

## ABSTRACT

The Ultraviolet Oxygen Sensor has been developed to quantitatively measure oxygen in a closed atmosphere. The essential elements of the instrument are: the ultraviolet source, an optical chopper, the sample cell, the photomultiplier tube, and the required electronic circuits. No monochromator or optical filter has been used. A Xenon discharge lamp with emission at 1470 angstroms is used with a sample path of 0.125 mm to provide a system sensitive to oxygen and insensitive to other gases found in a closed atmosphere environment. This configuration allows the use of a nondispersive optical system and an optical chopper to provide a double beam system. The oxygen concentration is determined by measuring the amount of energy absorbed through the sample cell. This measurement is compared to a reference signal obtained by directing the ultraviolet beam through an oxygen-free path to the photomultiplier. The electronic ratio of these two measurements results in a stable signal that is independent of variation in the source and detector. Preliminary testing of the prototype confirms the feasibility of this approach. Using various mixtures of oxygen and nitrogen, we have shown response from 0 to 100 percent oxygen. Since the scope of work allowed only very limited testing of the prototype, complete performance data is not yet available. We recommend that testing be continued to complete the design specifications for an engineering model of a flight-qualified Ultraviolet Oxygen Sensor and that the engineering model be built and tested.

## CONTENTS

| <u>SECTION</u> | <u>TITLE</u>  | <u>PAGE</u> |
|----------------|---|-------------|
| I              | INTRODUCTION  | 1           |
| II             | TECHNICAL DESCRIPTION                               | 2           |
|                | Principles of Operation                             | 2           |
|                | System Description                                  | 3           |
|                | Ultraviolet Source                                  | 3           |
|                | Optical Chopper                                     | 6           |
|                | Detector  | 6           |
|                | Electronics   | 6           |
|                | Source and Detector Power                           | 6           |
|                | Chopper Drive Circuit                               | 9           |
|                | Signal Amplification and Synchronous<br>Demodulator | 9           |
|                | Signal Linearization                                | 12          |
|                | Amplifier Power Supply                              | 14          |
| III            | TEST RESULTS  | 15          |
| IV             | RECOMMENDATIONS FOR FUTURE WORK                     | 20          |

LIST OF ILLUSTRATIONS

| <u>FIGURE NO.</u> | <u>TITLE</u>  | <u>PAGE</u> |
|-------------------|---|-------------|
| 1                 | Absorption Coefficients of Atmospheric Gases                  | 4           |
| 2                 | Emission Spectrum of EMR Lamp (50 mm Xenon)                   | 5           |
| 3                 | Response Curve of RCA C70128 Phototube                        | 7           |
| 4                 | UV O <sub>2</sub> Sensor, Schematic Diagram                   | 8           |
| 5                 | American Time Products Type 4A Driver                         | 10          |
| 6                 | Output of Oscillator  | 11          |
| 7                 | Electronic Module Test Points                                 | 13          |
| 8                 | Output of UV O <sub>2</sub> Analyzer                          | 16          |
| 9                 | Output of Detector as Measured after Input<br>Amplifier AR101 | 17          |
| 10                | Output of Logarithmic Amplifiers AR201 and AR202              | 18          |

## SECTION I

### INTRODUCTION

A system has been developed for the measurement of oxygen using the principle of the absorption of ultraviolet energy by oxygen. The purpose of this project was to develop a simple optical instrument which could be used to measure oxygen in space cabin environments. The primary requirement of this task was that no optical components be used other than the source, absorption path and detector. The solution to the problem was achieved by selecting as the source a xenon lamp with relatively narrow band emission in the far ultraviolet region of the spectrum. At 1475 Å, which is the peak emission of the source, oxygen has a very high absorption coefficient. This required that an absorption path of 0.1 mm be used. Since the absorption coefficients of other atmospheric gases are much lower than that of oxygen with this short a path length there is relatively no interference from other gases. The use of a photomultiplier of the 12-stage head-on type, therefore, made the system highly sensitive to atmospheric oxygen while being insensitive to changes in other gases in the atmosphere. Finally, to provide a system that would have very long term stability, a double-beam system was designed using an optical chopper. The chopper alternately directs the ultraviolet energy through a reference path and the absorption cell. The electronic ratio of the reference and sample signals provides an output dependent solely upon the concentration of oxygen in the atmosphere being monitored.

A prototype was fabricated and tested to prove the capability of this system. The results proved the feasibility of designing and qualifying for space use a simple system for the optical measurement of oxygen.

## SECTION II

### TECHNICAL DESCRIPTION

#### PRINCIPLES OF OPERATION

The Ultraviolet Oxygen Sensor uses the absorption of ultraviolet energy for the measurement of oxygen in closed atmospheric environments. The detector uses a nondispersive optical system whose primary components are the ultraviolet source, an optical chopper, and a photomultiplier tube. The ultraviolet source is a capillary stabilized 50 mm Xenon discharge lamp. The peak emission is at 1470Å. At this wavelength, the high absorption coefficient of oxygen allows the use of a very small sample path length. The path length used is 0.125 mm. The attenuation of the source energy along the optical path is given by Lambert's law:

$$I_{\lambda} = I_{0\lambda} e^{-k_{\lambda}x}$$

where:  $I_{0\lambda}$  = light intensity at a particular wavelength before entering an absorbing medium--either  $x$  or  $k = 0$ .

$k_{\lambda}$  = absorption coefficient to base  $e$  at a particular wavelength

$x$  = sample path length

The best possible conditions for monitoring the gas concentration exists for an isolated absorption band having a large absorption coefficient.

The Lambert equation can be rewritten as:

$$I = I_0 e^{-cvx}$$

where:  $c$  = absorption/concentration of molecules in a volume

$v$  = the volume through which the energy passes

The result is that the absorption coefficient  $k$  can be written in the form of concentration of material present and ultimately:

$$k_{\lambda} = k_{0\lambda} \frac{P}{760} \frac{273}{T}$$

where:  $P$  = gas pressure in mm Hg

$T$  = temperature absolute, K

$k_{0\lambda}$  = absorption coefficient at standard temperature and pressure to the base  $e$

The equation relating the dependence of energy attenuation upon gas pressure can be obtained by substituting the original equation and the equation for k:

$$I_{\lambda} = I_{0\lambda} e^{-k_{0\lambda} \frac{P}{760} \frac{237}{T} x}$$

Solving directly for the partial pressure of the gas at a chosen wavelength and fixed path is given as:

$$P = \frac{2.78T}{k_{0\lambda} x} \frac{\ln I_{0\lambda}}{I_{\lambda}}$$

The initial attenuated intensity is monitored over a narrow spectral band as the output current of a photomultiplier tube. The current output is given as

$$i_o = C I_o$$

where:

$$C = \text{a constant}$$

$$i_o = \text{current output}$$

When additional gases are present in the absorbing sample volume, the energy intensity equation can be modified approximately:

$$I_{\lambda} = I_{0\lambda} e^{-(k_1 + k_2 \dots + k_n) x}$$

where  $k_n$  absorption coefficient indicated for each of the various gases present.

On reducing this equation, the effect of their presence on the final signal is given as:

$$\ln \frac{I_o}{I} = \frac{k}{T} k_{n\lambda} P_n \quad \text{where } k = \text{a constant.}$$

This equation illustrates the necessity of isolating the absorption band or utilizing a large value in comparison to other gases commonly found in closed atmospheres.

Since gases other than oxygen have much smaller absorption coefficients in the wavelength region near 1470Å, the oxygen sensor is independent of changes in the concentration of other gases in the atmosphere. Figure 1 shows the absorption coefficients of several atmospheric gases. It can be seen that at 1470Å the absorption coefficient of oxygen is about 35 times that of water vapor. The selection of the source wavelength and sample path length has therefore resulted in a sensor which is insensitive to water vapor.

## SYSTEM DESCRIPTION

### Ultraviolet Source

The ultraviolet source is a 50-mm Xenon discharge lamp (EMR 582X-05). The emission of the source is shown in figure 2. About 85 percent of the

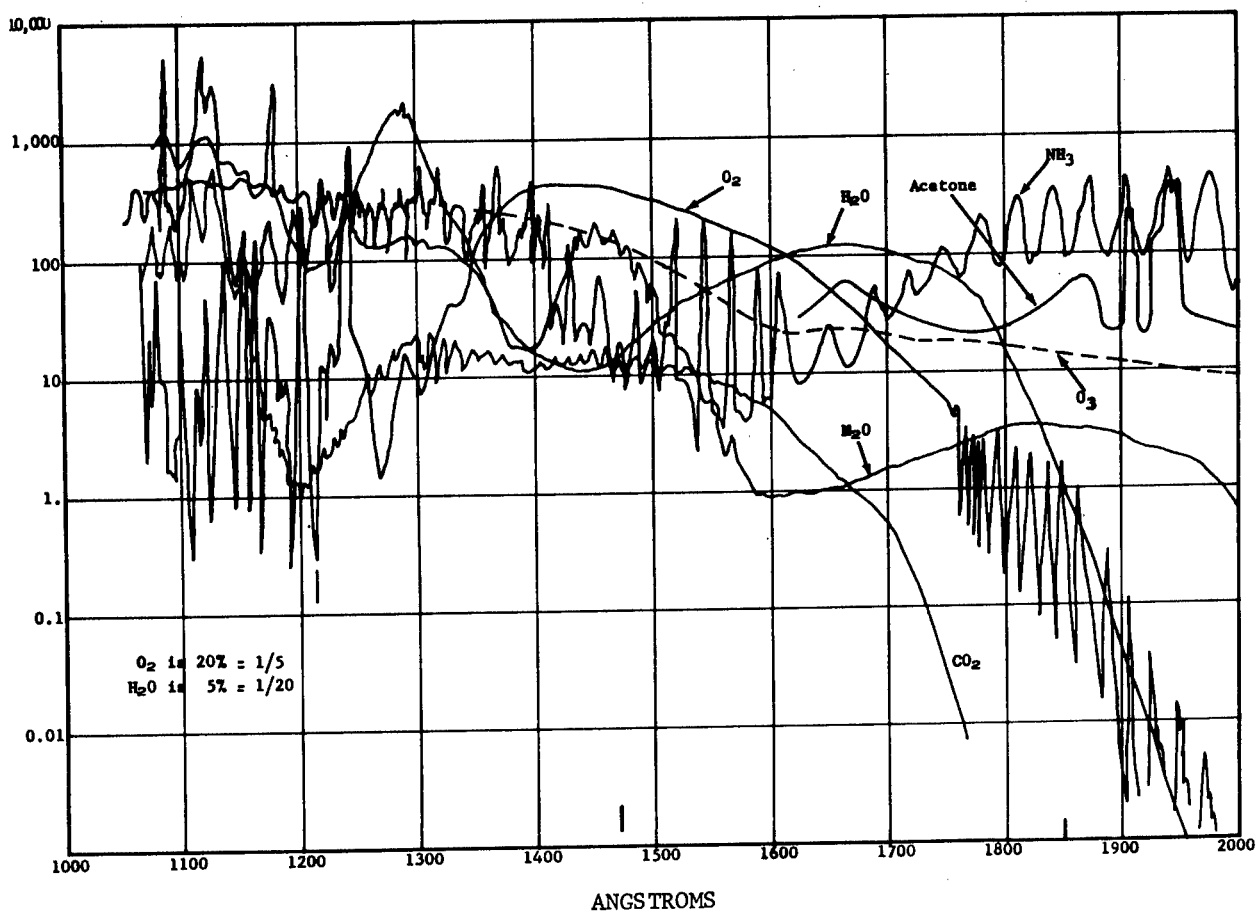
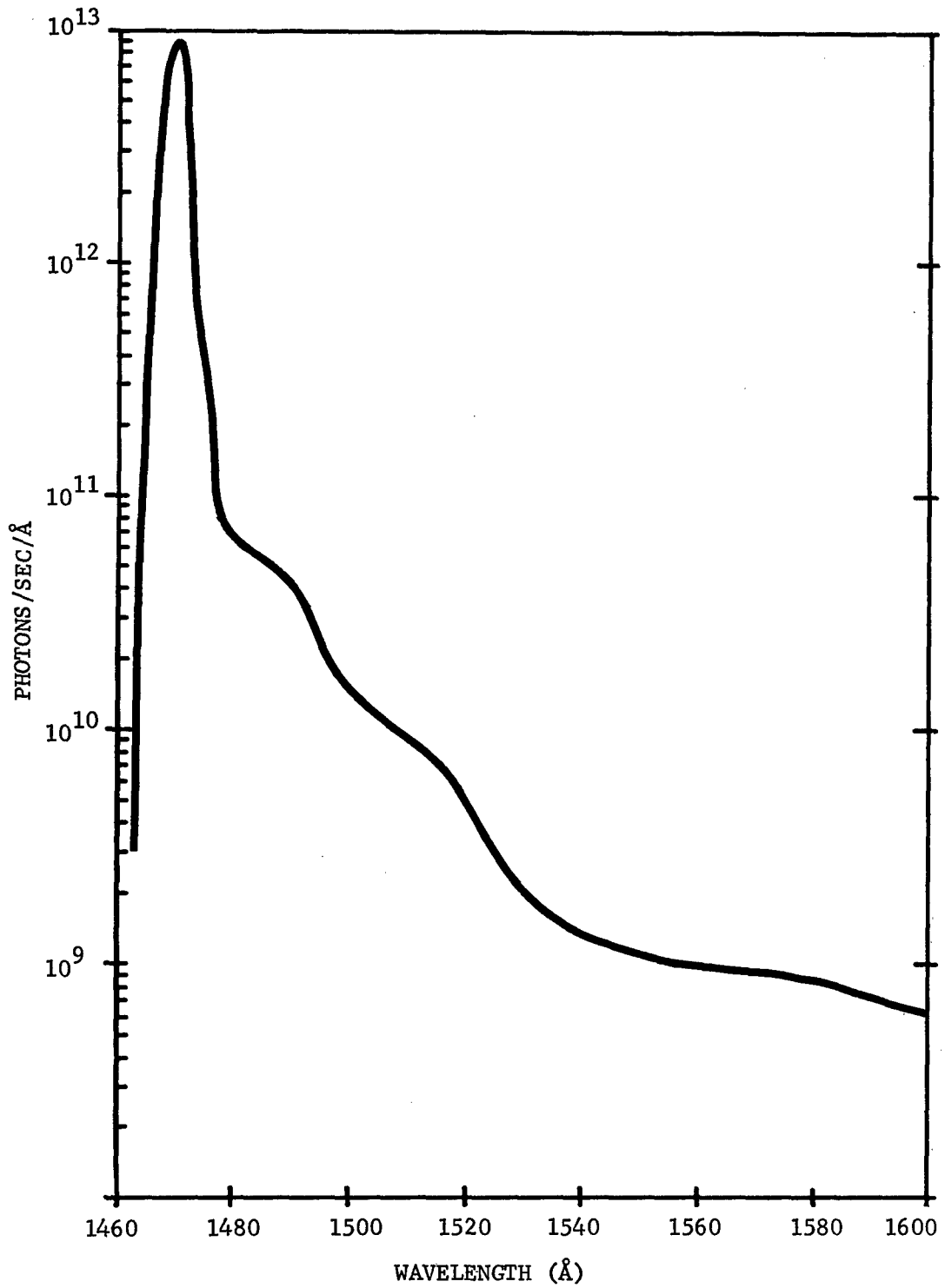

Figure 1. Absorption Coefficients of Atmospheric Gases



TYPICAL OUTPUT-PHOTONS/SEC/Å OF 582X XENON LAMP  
(RESOLUTION 7Å)

Figure 2. Emission Spectrum of EMR Lamp (50 mm Xenon)

radiated output is at  $1470\text{\AA}$ . Since this is the wavelength near which the absorption coefficient of oxygen is near a maximum, the concentration of the source energy at this wavelength permits the design of an oxygen sensor without the use of a dispersive optical system.

### Optical Chopper

An electronically driven tuning fork has been used as an optical chopper to provide a sample beam and reference beam for dual beam operation. By measuring the ratio of the energy through the sample and reference paths, automatic compensation is continuously provided for variations in the source and detector. The tuning fork is operated at about 300 Hz. It vibrates a small spherical mirror to alternately reflect the light from the source between the sample and reference paths. The mirror is positioned to image the light source onto the photocathode of the photomultiplier tube. The peak-to-peak amplitude of the mirror is 2.5 mm. This allows 1.25 mm between the sample and reference beams. The tuning fork provides a reference signal for synchronous demodulation of the photomultiplier signal.

### Detector

An RCA photomultiplier tube is used. It is a 12-stage, head-on photomultiplier with a cesium-telluride photocathode and lithium fluoride window. The response curve of the detector is shown in figure 3. The quantum efficiency of the detector is near its maximum at  $1470\text{\AA}$ . The detector is mounted in a block that is attached by reed springs to the base of the oxygen sensor. The springs permit the detector assembly to be loaded against the sample-reference window to form an oxygen-free reference path. The window is a 0.500 mm sapphire window, one-half of which is cut back 0.125 mm to provide the absorption path for the sample. Oxygen is excluded from the reference path by maintaining optical contact between the detector window and the sapphire window. Assembled in this way, the only optical parts that are required are the optical windows and the mirror used on the optical chopper.

### ELECTRONICS

The electronic circuits were designed to use solid state components throughout. The power supplies and amplifiers that were used are available as off-the-shelf encapsulated modules. Sufficient space is available in the instrument package to allow flexibility for experimentation. High density packaging techniques can reduce the size of the instrument to about one-half its current dimensions.

The Ultraviolet Oxygen Sensor requires isolated plus and minus 28v dc at 10 watts. The input power is distributed to operate the UV source, the chopper, the photomultiplier, amplifiers, and power supplies.

### Source and Detector Power

The source and detector are powered from a 1500-volt regulated power supply, EM401, shown in figure 4. The 1500-volt supply is an inverter that is

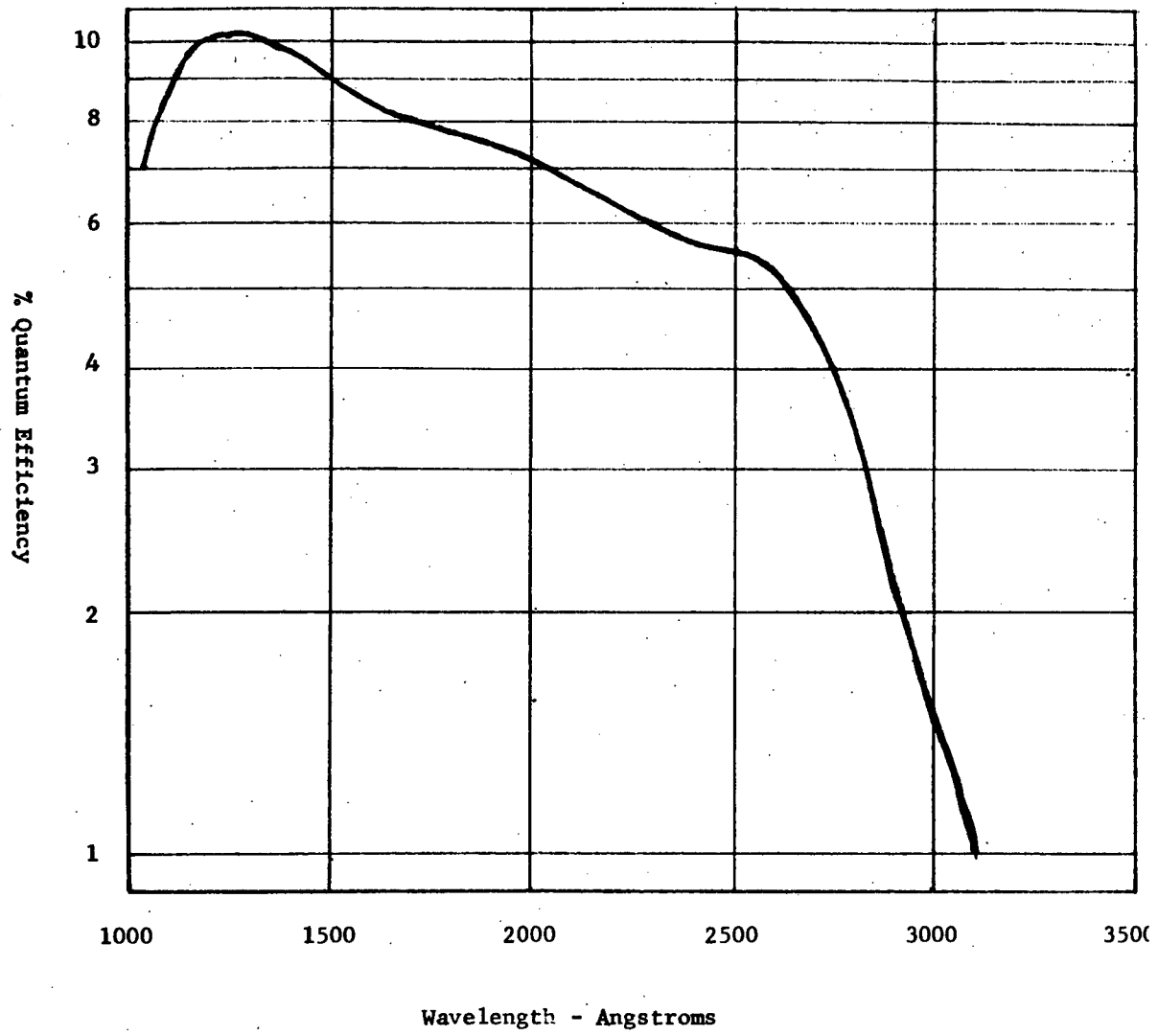

Figure 3. Response Curve of RCA C70128 Phototube

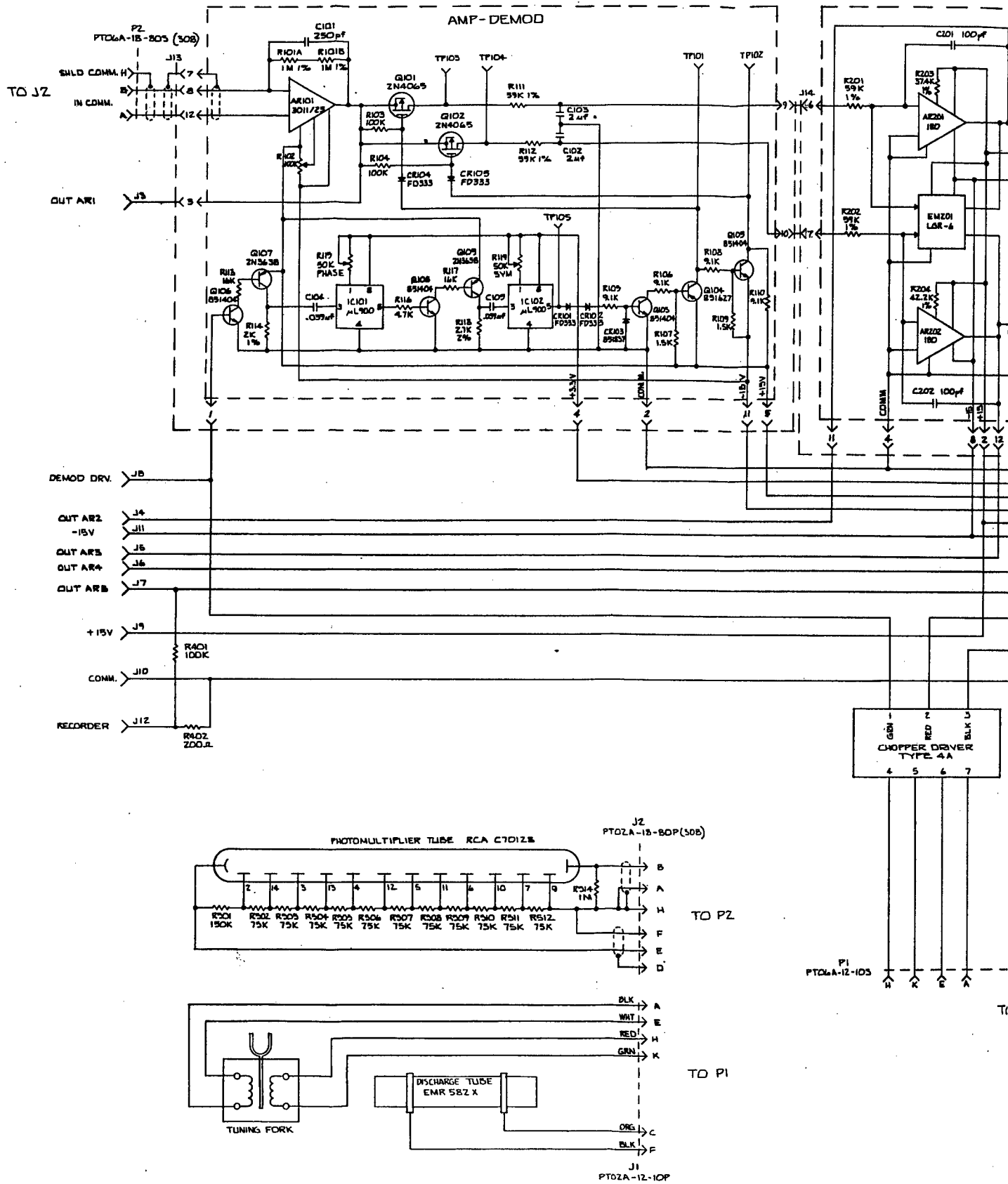

Figure 4. UV O<sub>2</sub> Sensor, Schematic Diag

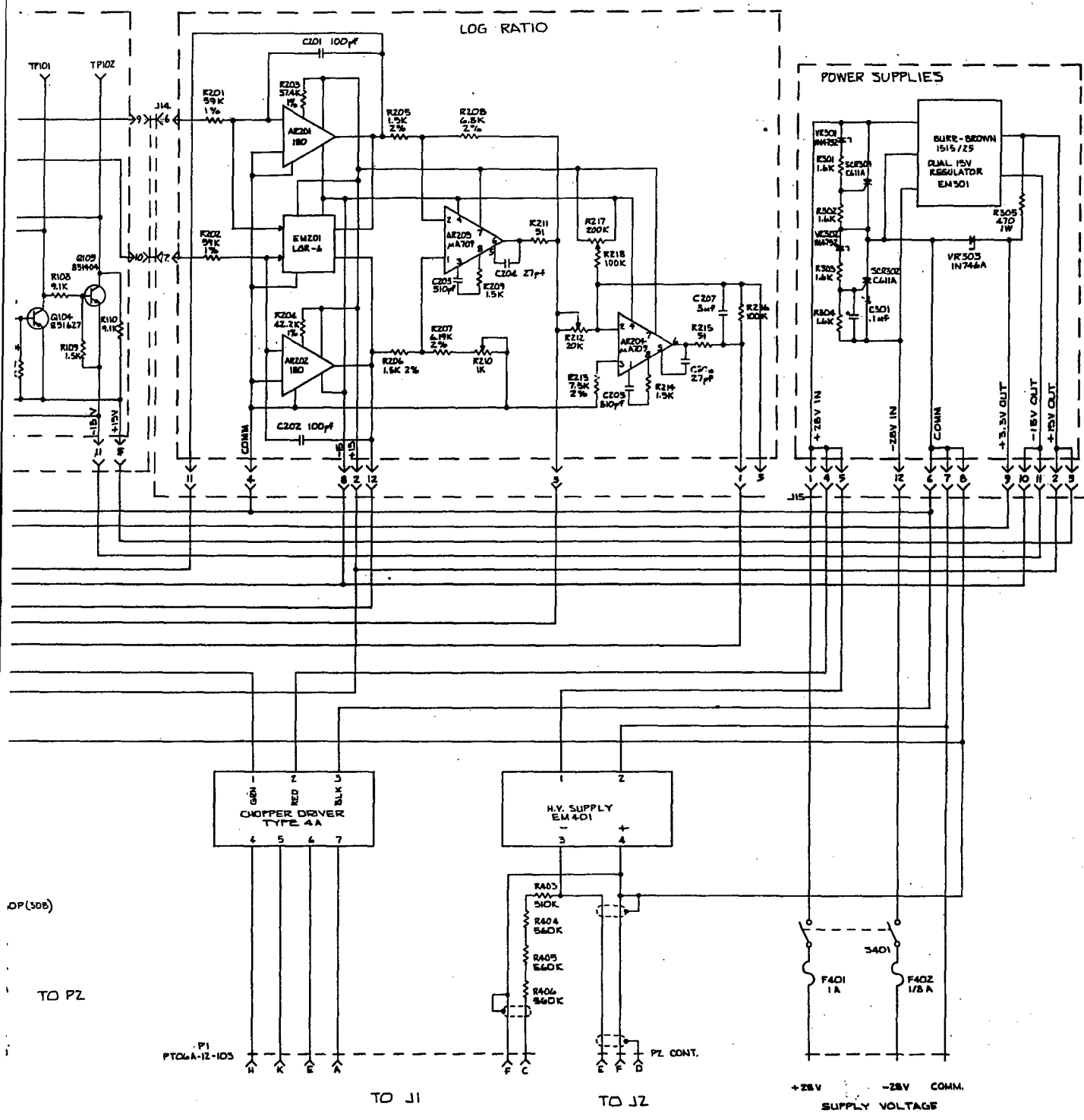

Figure 4. UV O<sub>2</sub> Sensor, Schematic Diagram

2

operated from the +28v dc input power. Use of the 1500-volt inverter to start the source provides for the maximum voltage that might be required for this purpose. After ionization of the Xenon in the discharge lamp, it becomes more conductive and operates at a typical value of 450 volts. A series resistor limits the current through the source. The 1500-volt inverter also powers the detector, an RCA C70178 photomultiplier.

#### Chopper Drive Circuit

The chopper drive circuit is a commercially available unit made by American Time Products (Type 4A Driver, figure 5).

Bias current for the pickup coil L2 and base current for Q1 is provided by the voltage drop across the SG22. Q1 is a common emitter stage that provides all the voltage amplification for the oscillator. The output of Q1 is coupled through the 22k resistor to the base of the emitter follower Q2. The bias current of Q2 is determined by the dc voltage at the collector of Q1. The emitter load of Q2 is L2, the drive coil of the fork.

The operation of the oscillator is as follows: Any disturbance of the fork changes the inductance of L1 so that a voltage variation appears across it. This variation changes the input current to Q1, which amplifies it. The amplified signal is used to drive a changing current through L2. The resulting change in the magnetic field around L2 moves the fork to reinforce the original variation sensed by L1, and oscillations at the forks resonant frequency build up. The amplitude of the fork is controlled by the 2.5k potentiometer that limits the drive current capability of the circuit.

#### Signal Amplification and Synchronous Demodulator

As the UV beam is alternated between the sample path and the reference path, the output current of the photomultiplier alternates between two levels representing the transmittance through each path. The photomultiplier output is injected into the chopper-stabilized operational amplifier, AR201, whose output voltage is proportional to the input current. The output is shown in figure 6. The switch Q101 and Q102 are operated to provide two outputs to the log ratio circuit representing the alternate half-cycles of the signal. In order to synchronize the switches with the signal, an output from the chopper (figure 6) is used to develop a square wave that can be adjusted in phase and used to turn Q101 and Q102 on and off at the proper times.

The output from the chopper is a sine wave which is fed through a resistor mounted in the chopper driver socket, to an amplifier consisting of Q106 and Q107, resulting in a rectangular wave that is then differentiated by C104 and the input resistance of IC101. The negative-going spike switches the output of the  $\mu$ L900 to its positive supply voltage (+3.3v). The output then returns to zero after a period of time determined by C104, R114 and R115. This output is then squared up by an amplifier consisting of Q108 and Q109, differentiated by C105 and the input resistance of IC102. Again, the negative spike switches the output of IC102 to +3.3v, and since the timing of the

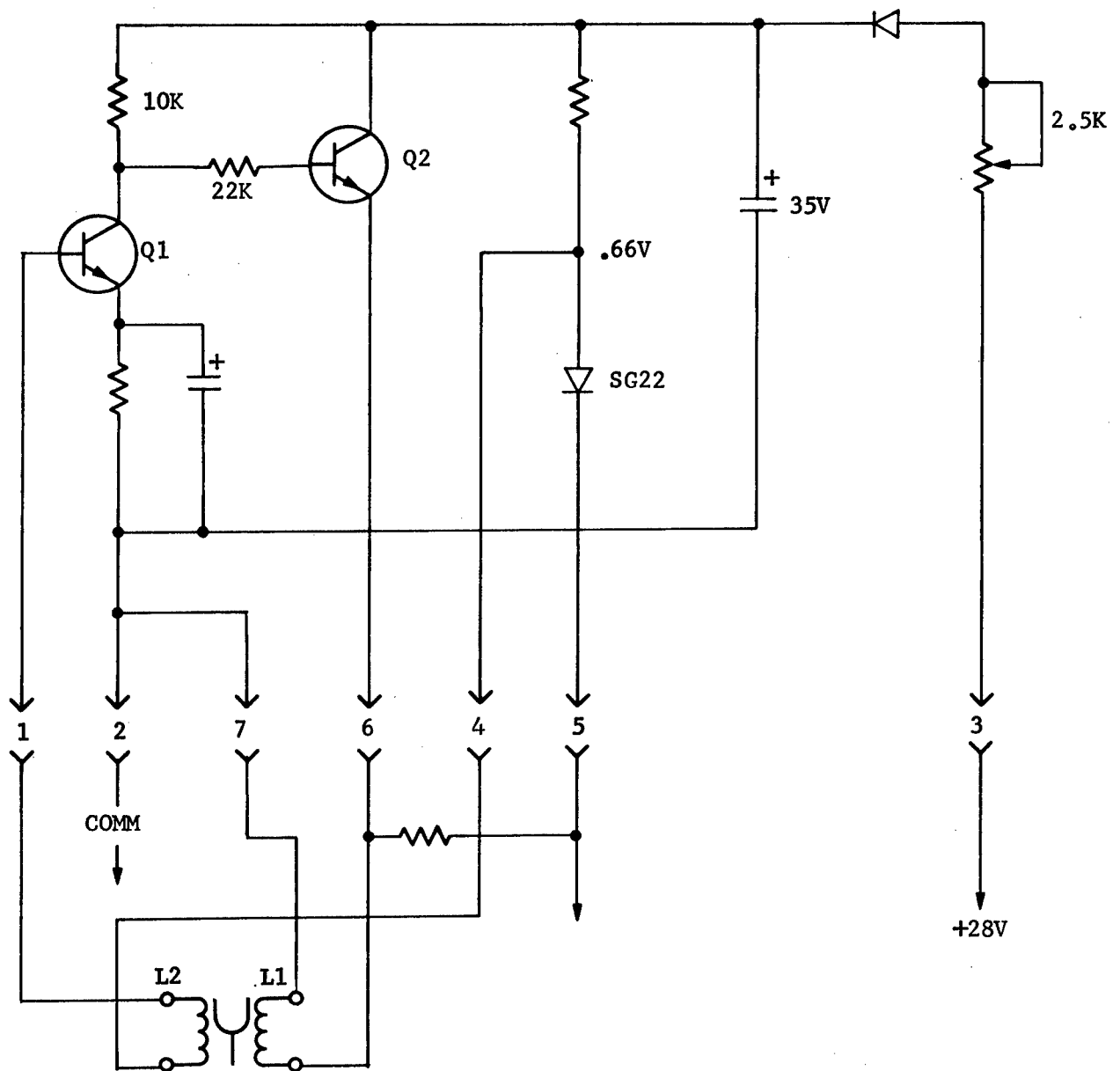
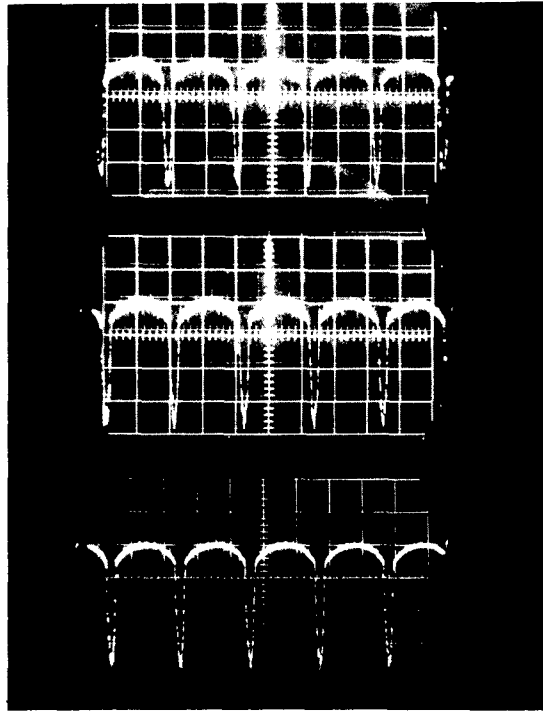

Figure 5. American Time Products Type 4A Driver



|             |         |
|-------------|---------|
| J8 "OSC"    | Bottom  |
| V-200 mV/cm | line is |
| H-2 msec/cm | 0 volts |

Figure 6. Output of Oscillator

negative spike is controlled by the time constant of C104, R114 and R115, the leading edge of the outer square wave is adjustable in relationship to the input signal. The width, and therefore symmetry, is controlled by the time constant of C105, R118 and R119. This output (figure 7a) is fed through level-shifting diodes CR101 and CR102 to Q103. The square waves at the collectors of Q104 and Q105 are 180° out of phase, and can be observed at test points TP101 and TP102 (figure 7b). The negative halves of the square waves are used to turn on Q101 and Q102. The positive halves are blocked by CR104 and CR105. The output of the switches can be observed at TP103 and TP104 (figures 7c and 7d).

In setting up the switch circuitry, use an oscilloscope at TP101 or TP102 to adjust the symmetry and at TP103 and 104 to adjust the phase.

### Signal Linearization

A logarithmic ratio circuit is used to linearize the amplified detector signal. The outputs from the synchronous switches are filtered and fed to operational amplifiers AR201 and AR202. In the feedback circuits of these amplifiers are matched logarithmic devices contained in the Nexus logarithmic module LGR-6 (referred to as EM 201).

The output of each amplifier is:

$$e_o = a \log \frac{e_i}{R_i}$$

where:  $e_o$  is the output voltage

$e_i$  is the input voltage

$R_i$  is input resistor

A is a constant  $\cong 60$  mv.

The outputs of AR201 and AR202 are fed to opposite inputs of AR203 to give at the output of AR203 the difference of the two logarithms.

That is,  $e_{o203} = A(e_{o202} - e_{o201})$

The reference signal is  $e_{o202}$ . It should be a constant since it is the logarithm of the current resulting from the energy through the reference path. The sample signal,  $e_{o201}$ , is the logarithm of the current resulting from the energy through the sample path. This current is theoretically an exponential function of the oxygen concentration; therefore  $e_{o201}$  is proportional to the  $O_2$  concentration.

The output of AR203 is also a linear function of  $O_2$  concentration. This output is amplified by AR204. The zero level is adjustable by R217, the gain by R212. The feedback is accessible at the terminals of the boards so that

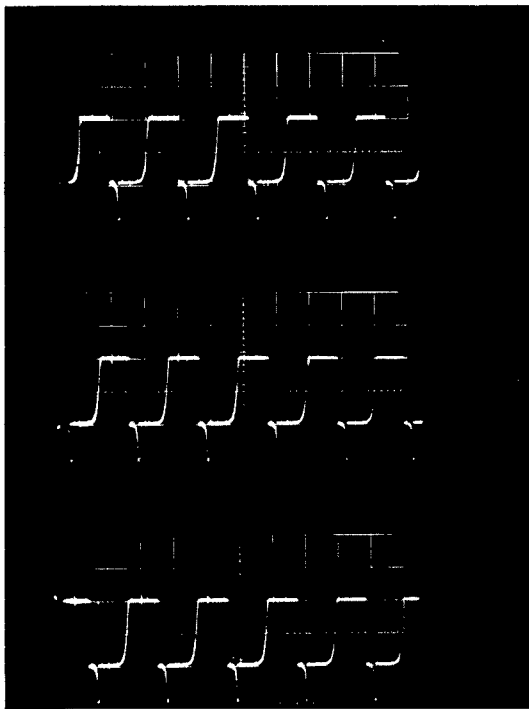

**A** TP105  
 V-1 V/cm H-2 msec/cm  
 Second Line Up is 0 Volts

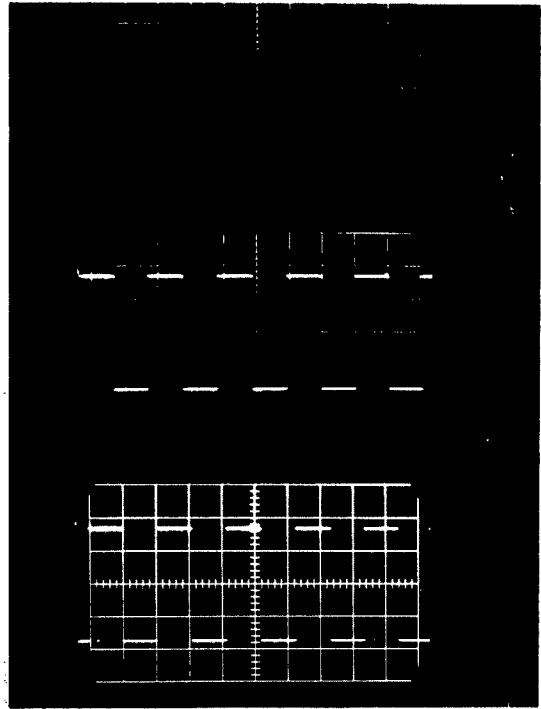

**B** TP102 CL is 0 Volts  
 V-10V/cm H-2 msec/cm

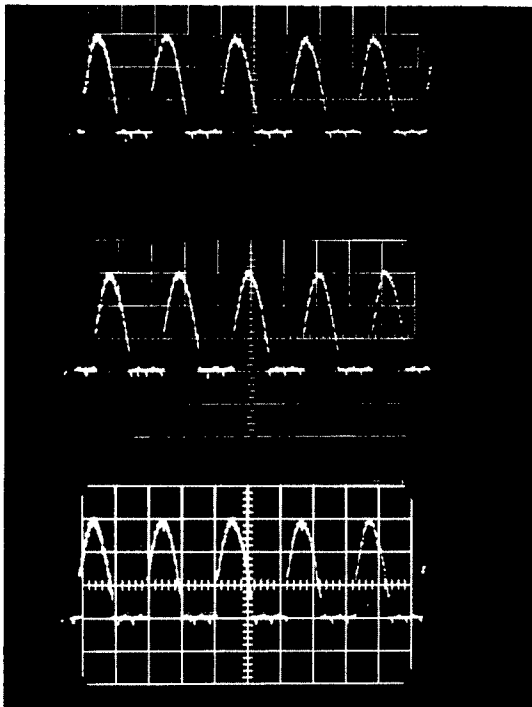

**C** TP104  
 V-200 mV/cm H-2 msec/cm  
 Second line is 0  
 Atmosphere - No Flow

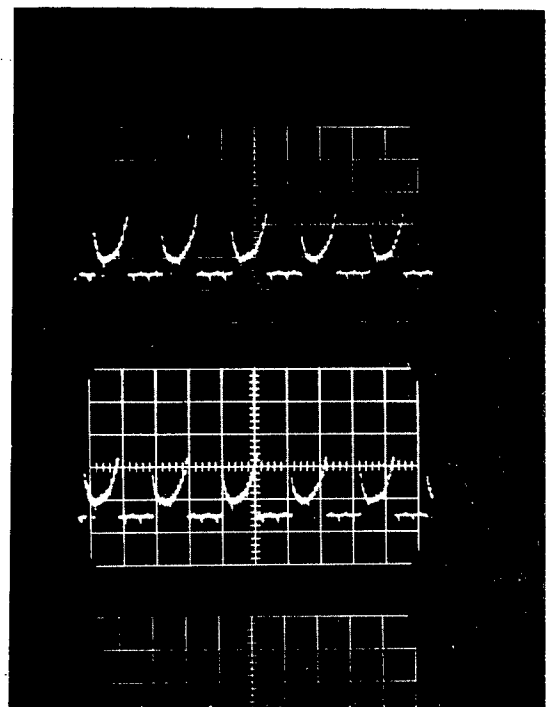

**D** TP103  
 V-200 mV/cm H-2 msec/cm  
 Second line is 0 volts  
 Atmosphere - no flow

Figure 7. Electronic Module Test Points

temperature compensation can be added, since the absorption of UV by  $O_2$  is dependent on temperature.

#### Amplifier Power Supply

The instrument is designed for  $\pm 28$ v supply voltages. A series regulator package (EM301) provides  $\pm 15$  volts for the operational amplifiers. The +28 volt input powers the high voltage inverter and the chopper driver. Since the chopper amplitude is a function of the supply voltage, the +28 input must be held to  $28 \pm 0.05$  volts. If an unregulated supply is used, a regulator would have to be added for the driver.

Overvoltage protection circuits are provided. If either of the input voltages exceeds 32 volts, the corresponding Zener VR301 or VR302 breaks down and fires its SCR which will, in turn, blow a fuse.

VR303 provides +3.3 volts from the +15 volt supply for the integrated circuits in the phase shifter.

When the power supply board is removed, the +28 volt line to the high voltage supply and the chopper driver is opened.

### SECTION III

#### TEST RESULTS

A series of tests were conducted to establish the performance characteristics and to determine the limitations of the prototype Ultraviolet Oxygen Sensor. All of the tests were done at ambient laboratory conditions. The temperature typically varied from 25 to 28C. Since only very limited testing could be done, the primary purpose of the tests was to prove the feasibility of using a nondispersive optical instrument for measuring oxygen in atmospheric environments.

Figure 8 shows the instrument response to samples of 0 to 100 percent oxygen. The balance of the mixture was nitrogen. Since this signal has been processed by a logarithmic amplifier, the curve should have been linear. The sharp departure from linearity is probably due to the use of too long a sample path. Our breadboard tests results showed that the required sample path is 0.125 mm. When we assembled the prototype, it was difficult to maintain optical contact between the photomultiplier window and the sample-reference path window. The actual sample path is probably greater than 0.125 mm. The position of the photomultiplier tube was adjusted to reduce leakage of the sample into the reference path. The adjustment of the photomultiplier tube may have increased the sample path length so that higher concentrations of oxygen cause nearly total absorption of the ultraviolet energy. Another analysis of this non-linearity can be made by observing the photomultiplier signal before demodulation. Figure 9 shows the reference signal and the sample signal as a function of oxygen concentration. Since the response is plotted on a logarithmic scale, the curve should be linear. Furthermore, if the reference path were completely sealed, the reference signal vs. oxygen concentration would be parallel to the X-axis. Since the reference signal does vary with oxygen concentration, there is obviously leakage of the sample into the reference path. Since the reference path is actually performing as a second "sample path" with a greatly reduced path length compared to the sample path, the reference signal curve is linear on the logarithmic scale. Curve  $e_1$ , the signal from the sample path, shows the nonlinearity which is also obtained from the final output shown in figure 8. It is therefore expected that a reduction of the sample path length would result in a linear output over the range of 0 to 100 percent oxygen (note that this is at ~760 mm Hg).

The performance of the logarithmic amplifiers in linearizing a logarithmic signal can be seen from figure 10. This shows, on rectangular coordinates, the sample and reference signals plotted against oxygen concentration. These curves have the same shape as those of figure 9.

One test was performed to determine the instrument's sensitivity to water vapor. Ambient room air at 27C and 50 percent relative humidity was pumped through the sample cell and the signal was recorded. A calcium sulfate

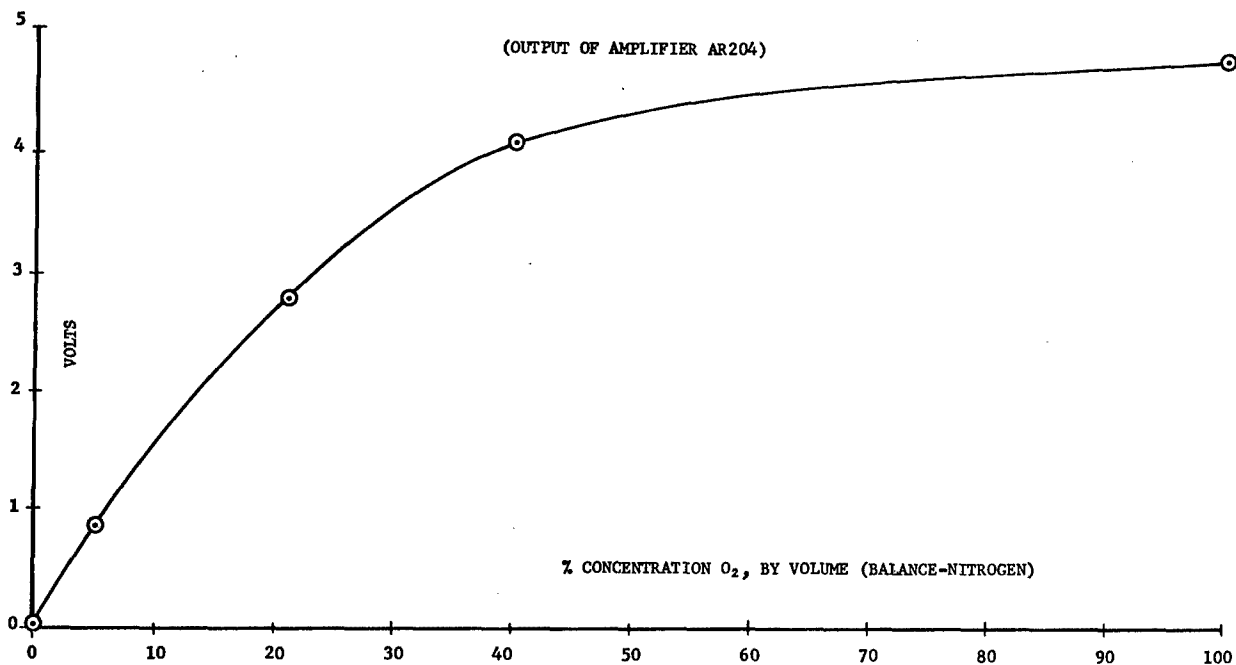

Figure 8. Output of UV O<sub>2</sub> Analyzer

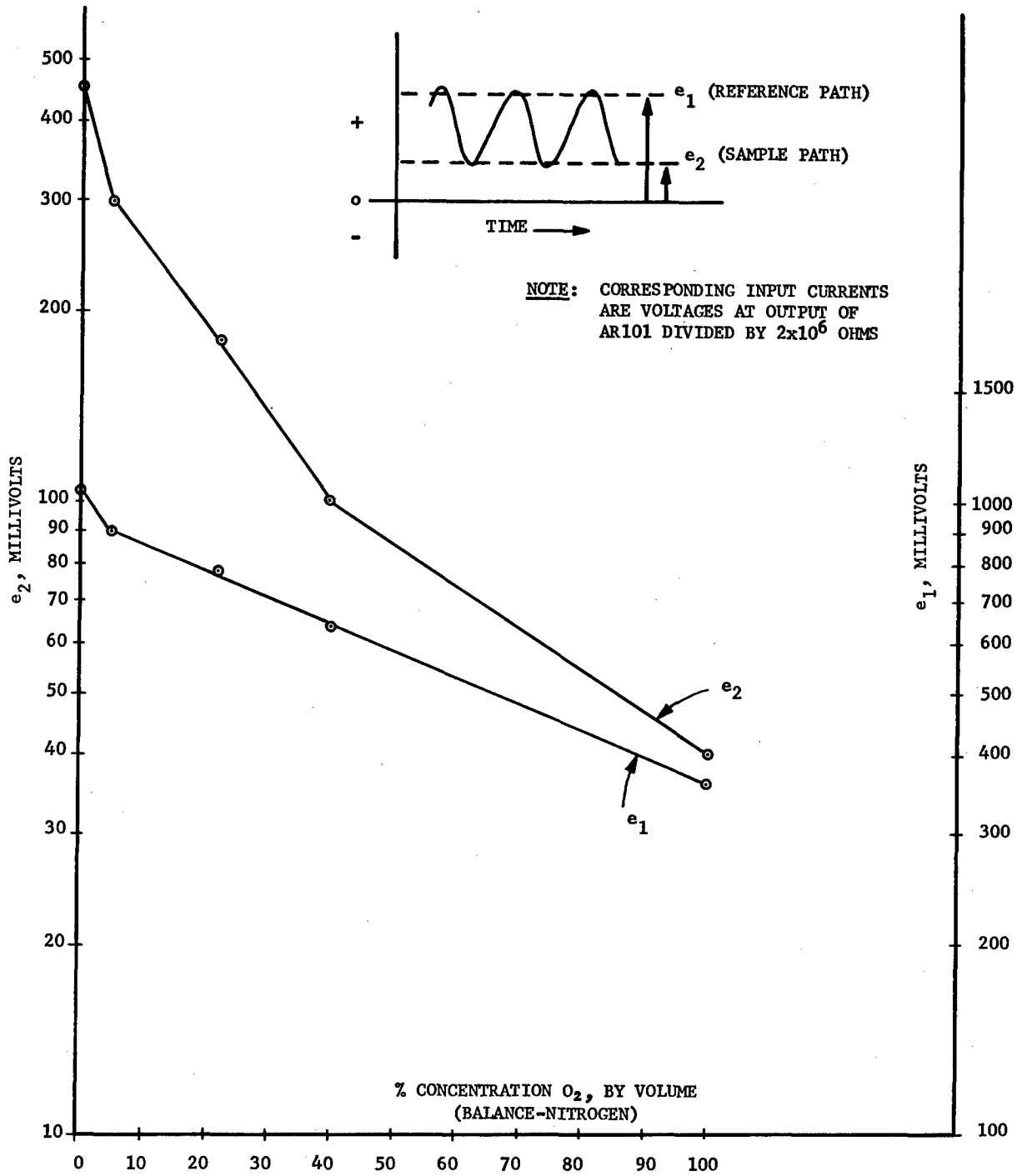

Figure 9. Output of Detector as Measured after Input Amplifier AR101

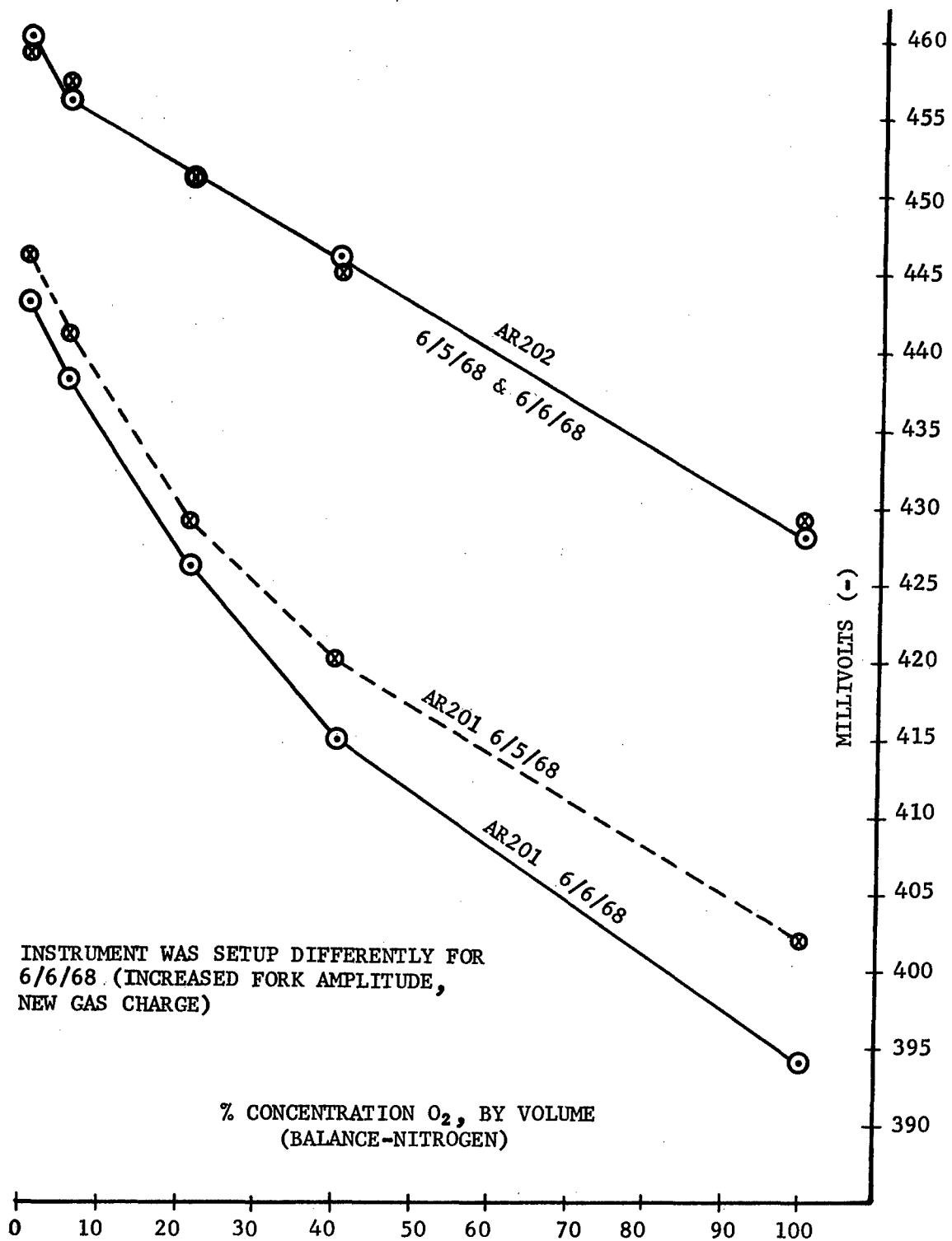

Figure 10. Output of Logarithmic Amplifiers AR201 and AR202

drying tube was then placed between the pump and the sample cell and no change in signal was noted, indicating that the instrument is insensitive to atmospheric water vapor.

The stability of the system was evaluated by flowing nitrogen through the sample cell for 3 hours and recording the output signal. The signal was constant to within 0.3 percent oxygen. The response to step changes in gas concentration was recorded at various concentrations between 0 and 100 percent oxygen. The signal for a given gas mixture was always within one division of the previous measurement.

The sensitivity of the sensor to position was determined by operating it while varying the orientation of the unit. A 90° change in orientation caused a change in signal equivalent to less than 2 percent oxygen. This may be due to a slight sag in the vanes of the chopper that would change the energy reaching the detector. This can probably be overcome by using a chopper with a torsional motion of the tines, thus allowing the use of a much shorter tuning fork assembly while still maintaining the required beam deflection between the sample and reference paths.

## SECTION IV

### RECOMMENDATIONS FOR FUTURE WORK

Although the opportunity existed for only limited testing of the prototype, the test results prove the feasibility of using a very simple optical instrument for measuring oxygen atmospheric environments. By proper selection of the source, sample path, and detector, the complexities associated with dispersive optical systems are not necessary for measuring oxygen. Since only a brief period of time was available for testing the prototype, our recommendations are only preliminary. The prototype is a completely self-contained system and the final recommendations will be developed after a thorough program of prototype testing is completed.

The most essential improvement required for the UV Oxygen Sensor is the isolation of the reference path from the sample path. This can be accomplished by using essentially the same methods as in the prototype but including the use of cement to permanently hold the sapphire window to both the photomultiplier tube and to the housing containing the source and chopper. This should provide total exclusion of the sample gas from the reference path while maintaining the required 0.125 mm sample path.

Another refinement of the sample cell design will be the provision of an additional surface, at the edge of the sample cell, against which the photomultiplier window can bear. This will alleviate the problem encountered in maintaining optical contact between the sapphire window and the photomultiplier tube. The fabrication of the windows and photomultiplier can be held to a greater precision so that each of the windows' surfaces are parallel to each other and perpendicular to the axis of the photomultiplier envelope. This will facilitate the assembly of the system so that no air can enter the reference path.

The present design uses a tuning fork chopper to produce the dual beam required for the ratio measuring system. The chopper and the Xenon discharge lamp must be enclosed in a nitrogen-filled chamber. Three O-rings are used in this chamber, two as seals for the housing, and one to seal the electrical connector. There is also a needle valve through which the chamber can be evacuated and filled with dry nitrogen. The O-rings and the valve can be eliminated by designing a system that will use only hermetic seals. This technique will result in a greatly extended operating life of the sensor.

An alternate approach to the design of the source and optical chopper might result in a system that would not require the use of a nitrogen purge and hermetic seals. It should be possible to design the source to include an internal pair of electrodes to which an electrostatic or magnetic field could be applied to deflect the electron beam of the source in the manner analogous to that used in a cathode ray tube. Then the source, sample-reference window,

and photomultiplier interfaces could be sealed to exclude the atmosphere from the optical path.

A substantial reduction in both weight and volume of the oxygen sensor is immediately possible using high density packaging techniques. The prototype system was designed as two separate units. This was done primarily as a convenience for independently testing the electronics and sensor portions of the system. The design can be modified to provide a single unit, thus eliminating the external cabling and connectors required for the prototype.

## DOCUMENT CONTROL DATA - R &amp; D

(Security classification of title, body of abstract and indexing annotation must be entered when the overall report is classified)

|   |   |   |  |
|---|---|---|--|
| 1. ORIGINATING ACTIVITY (Corporate author)<br>Beckman Instruments, Inc.<br>Advanced Technology Operations<br>2400 Harbor Blvd.<br>Fullerton, California   |   | 2a. REPORT SECURITY CLASSIFICATION<br>Unclassified  |  |
|   |   | 2b. GROUP<br>N/A  |  |
| 3. REPORT TITLE<br><br>ULTRAVIOLET OXYGEN SENSOR  |   |   |  |
| 4. DESCRIPTIVE NOTES (Type of report and inclusive dates)<br>Final Technical Report - June 1967 to July 1968  |   |   |  |
| 5. AUTHOR(S) (First name, middle initial, last name)<br>Allen Kaplan<br>Clint Jurgens<br>Kang Yu  |   |   |  |
| 6. REPORT DATE<br>January 1969  | 7a. TOTAL NO. OF PAGES<br>21  | 7b. NO. OF REFS<br>0  |  |
| 8a. CONTRACT OR GRANT NO.<br>F33615-67-C-1775   | 9a. ORIGINATOR'S REPORT NUMBER(S)<br>FR-2499-101                            |   |  |
| b. PROJECT NO. 6373   |   |   |  |
| c. Task No. 637302  | 9b. OTHER REPORT NO(S) (Any other numbers that may be assigned this report) |   |  |
| d. Work Unit No. 637302044  | AMRL-TR-68-145  |   |  |
| 10. DISTRIBUTION STATEMENT<br><br>This document has been approved for public release and sale;<br>its distribution is unlimited.  |   |   |  |
| 11. SUPPLEMENTARY NOTES   |   | 12. SPONSORING MILITARY ACTIVITY<br>Aerospace Medical Research Laboratory<br>Aerospace Medical Division<br>Air Force Systems Command<br>Wright-Patterson Air Force Base, Ohio |  |
| 13. ABSTRACT The Ultraviolet Oxygen Sensor has been developed to quantitatively measure oxygen in a closed atmosphere. The essential elements of the instrument are: the ultraviolet source, an optical chopper, the sample cell, the photomultiplier tube, and the required electronic circuits. No monochromator or optical filter has been used. A Xenon discharge lamp with emission at 1470 angstroms is used with a sample path of 0.125 mm to provide a system sensitive to oxygen and insensitive to other gases found in a closed atmosphere environment. This configuration allows the use of a non-dispersive optical system and an optical chopper to provide a double beam system. The oxygen concentration is determined by measuring the amount of energy absorbed through the sample cell. This measurement is compared to a reference signal obtained by directing the ultraviolet beam through an oxygen-free path to the photomultiplier. The electronic ratio of these two measurements results in a stable signal that is independent of variation in the source and detector. Preliminary testing of the prototype confirms the feasibility of this approach. Using various mixtures of oxygen and nitrogen, we have shown response from 0 to 100 percent oxygen. Since the scope of work allowed only very limited testing of the prototype, complete performance data is not yet available. We recommend that testing be continued to complete the design specifications for an engineering model of a flight-qualified Ultraviolet Oxygen Sensor and that the engineering model be built and tested. |   |   |  |

| 14. KEY WORDS  | LINK A |    | LINK B |    | LINK C |    |
|--|--------|----|--------|----|--------|----|
|  | ROLE   | WT | ROLE   | WT | ROLE   | WT |
| Ultraviolet Oxygen Sensor<br>UV Sensor<br>Optical O <sub>2</sub> Sensor<br>Space Oxygen Sensor |        |    |        |    |        |    |