

AIR FORCE REPORT NO.
SAMSO-TR-69-187

AEROSPACE REPORT NO.
TR-0200(4250-40)-7

AD 693559

Design and Testing of Ablation Models with Controlled Pressure Gradients

Prepared by W. T. BARRY
Materials Sciences Laboratory
The Aerospace Corporation
and E. B. FISHER
Cornell Aeronautical Laboratory

69 FEB 28

Laboratory Operations
THE AEROSPACE CORPORATION

Prepared for SPACE AND MISSILE SYSTEMS ORGANIZATION
AIR FORCE SYSTEMS COMMAND
LOS ANGELES AIR FORCE STATION
Los Angeles, California

SEP 29 1969

THIS DOCUMENT HAS BEEN APPROVED FOR PUBLIC
RELEASE AND SALE; ITS DISTRIBUTION IS UNLIMITED

32

Air Force Report No.
SAMSO-TR-69-187

Aerospace Report No.
TR-0200(4250-40)-7

DESIGN AND TESTING OF ABLATION MODELS
WITH CONTROLLED PRESSURE GRADIENTS

Prepared by
W. T. Barry
Materials Sciences Laboratory
Aerospace Corporation

and

E. B. Fisher
Cornell Aeronautical Laboratory

69 FEB 28

Laboratory Operations
THE AEROSPACE CORPORATION

Prepared for
SPACE AND MISSILE SYSTEMS ORGANIZATION
AIR FORCE SYSTEMS COMMAND
LOS ANGELES AIR FORCE STATION
Los Angeles, California

This document has been approved for public
release and sale; its distribution is unlimited

FOREWORD

This report is published by The Aerospace Corporation, El Segundo, California, under Air Force Contract No. F04701-68-C-0200.

This report, which documents research carried out from September 1967 through June 1968, was submitted on 14 February 1969 to Lieutenant Jerry Smith, SMTM, for review and approval.

Approved



W. C. Riley, Director
Materials Sciences Laboratory

Publication of this report does not constitute Air Force approval of the report's findings or conclusions. It is published only for the exchange and stimulation of ideas.

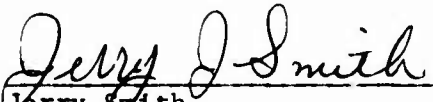

Jerry Smith
Lieutenant, United States Air Force
Project Officer

ABSTRACT

Studies of high-pressure ablation mechanisms have been hampered by lack of suitable ablation models. A technique has been developed to contour wedge models for testing in the Cornell Aeronautical Lab. wave superheater to give either a constant pressure, a constant heat transfer, or a constant pressure gradient up to the limit of the facility. Preliminary testing with a standard carbon phenolic composite shows that high recession rates occur even in the absence of a significant pressure gradient.

BLANK PAGE

CONTENTS

FOREWORD	11
ABSTRACT	111
NOMENCLATURE	v11
I. INTRODUCTION	1
II. TEST FACILITY	3
III. MODEL DEVELOPMENT	5
IV. ABLATION TESTING	13
V. CONCLUSIONS	17
REFERENCES	19
APPENDIX. DESIGN PROCEDURE FOR A CONTOURED WEDGE WITH AN ARBITRARY PRESSURE GRADIENT	21

TABLES

1. Test Conditions	2
2. Typical Test Data for Standard Carbon Phenolic	15

FIGURES

1.	Water-Cooled Holder Configuration	4
2.	Comparison of the Model Contours	6
3.	Calibration Model Instrumentation	7
4.	Typical Calibration Model	8
5.	Pressure Distribution from the Compromise Contour	9
6.	Pressure Distributions on the Prandtl-Meyer Constant- Pressure Contour	10
7.	Heat Flux and Shear Stress Distributions	12
8.	Configurations of Wedge Models	14
9.	Comparison of Contoured Ablation Specimen and Flat Specimen	16

NOMENCLATURE

H	Enthalpy, Btu/lb
M	Mach number
p	Pressure, atm
q	Cold wall heat flux, Btu/ft ² -sec
s	Distance along wetted surface from holder stagnation point, in. or ft
T	Temperature, °R
t	Time, sec
t _i	Time of initial exposure of the model to the flow measured from a reference time zero to the time of initial flow or the time the teflon cap blew off
Δt	Time a model is exposed to the flow, sec
U	Velocity, ft/sec
X	Distance from the rotor, in.
x _s , y _s	Orthogonal contour coordinates with origin at the sample leading edge, in.
α	Angle of attack
ρ	Density, lb/ft ³

Subscripts

e	Local conditions just outside boundary layer
s	Gas conditions at model stagnation point, i.e., stagnation conditions
∞	Free stream gas conditions

Superscript

o	Total or reservoir conditions
---	-------------------------------

BLANK PAGE

I. INTRODUCTION

An understanding of the mechanisms by which thermochemical processes couple with high-pressure flow fields to produce excessive ablation rates is necessary before reliable analytical procedures can be developed for sizing nose tips and flaps. The development of improved ablative tip materials is also hampered by our lack of understanding of these mechanisms. Among the major experimental difficulties has been the problem of characterizing the local environment both mechanically and thermally. The ablation models most frequently used were conical tips of various nose radii and half angles,¹ 45-deg flat wedges,² and inclined cylinders.³ Both of the latter employed water-cooled leading edges. In all these cases, and especially in the tip models, large and constantly changing pressure gradients along the model axis made interpretation of the results difficult. This was seriously aggravated by the fact that the models changed shape during the test and the environment became even more difficult to define.

Nevertheless, there was a high-pressure gradient, and, for tip models, the rate of removal could be correlated with stagnation pressure.^{1,2} As a consequence, several plausible theories were evolved in which pressure gradient shear was the driving mechanism.^{2,4}

In addition to the macroscopic pressure gradient, it was postulated that surface roughness produced by inhomogeneous ablation (due to local difference in resin content, fiber content and density) was coupling with the boundary layer to produce large local forces and heat transfer rates, which could be responsible for the massive ablation rates observed.

It became apparent that, in order to get a quantitative estimate of how the various processes and material variables were interacting, it would be necessary to develop improved ablation models. The ideal model would have a relatively large area to minimize or control the effect on resin-reinforcement geometries and would be shaped to control pressure, pressure gradient, and heat transfer so that each of these variables could be held constant over the entire model surface. It was with this objective, therefore, that the following work was undertaken.

Table 1. Test Conditions

MODEL	T° , °R	H° , Btu/lb	p° , atm	T_s , °R	p_s , atm	s , in.
Trial Curve	5900	1790	101	5880	81	0.541
(1) P-M $dp/dx = 0$	5730	1730	100	5710	80	0.551
(2) P-M $dp/dx = 0$	6240	1940	101	6220	81	0.510
(3) P-M $dp/dx = 0$	6520	2070	99	6485	79	0.475
(4) P-M $dp/dx = 10$	6260	1950	109	6240	87	0.546

MODEL	M_e	U_e , ft/sec	T_e , °R	H_e , Btu/lb	p_e , atm	ρ_e	$Re \times 10^{-6}$
Trial Curve	1.25	4190	4960	1440	32	0.253	21.4
(1) P-M $dp/dx = 0$	1.15	3850	4930	1430	37	0.286	22.3
(2) P-M $dp/dx = 0$	1.32	4520	5190	1540	29.5	0.220	19.5
(3) P-M $dp/dx = 0$	1.25	4420	5550	1680	31	0.222	18.6
(4) P-M $dp/dx = 10$	1.25	4320	5300	1580	34	0.255	21.5

II. TEST FACILITY

The Cornell Aeronautical Labs. (CAL) wave superheater test facility⁶ was chosen because of the high pressures and relatively large flow field that are available. This hot gas generator is a rotating multiple-shock-tube device capable of delivering a 5-lb/sec flow of uncontaminated test gas with effective reservoir conditions up to 2800-Btu/lb enthalpy and 130-atm pressure for durations up to 15 sec. Energy is transferred from the high-pressure, preheated test gas by a shock wave mechanism in the 288 shock tubes mounted on the periphery of a rotor. The resulting steady flow from the rotor is supersonic, with height and width dimensions of approximately 1.5 and 0.5 in. The high power density (up to 27,000 hp/in.²) of the freely expanding jet is ideally suited for high heat transfer, pressure, and shear stress testing. The flow from the free jet is inherently unsymmetrical; however, this effect was minimized in the model design. For this study we selected a stagnation pressure of 80 atm so that the ablation data could be compared with those of earlier experiments.² Details of the hot gas environment are given in Table 1.

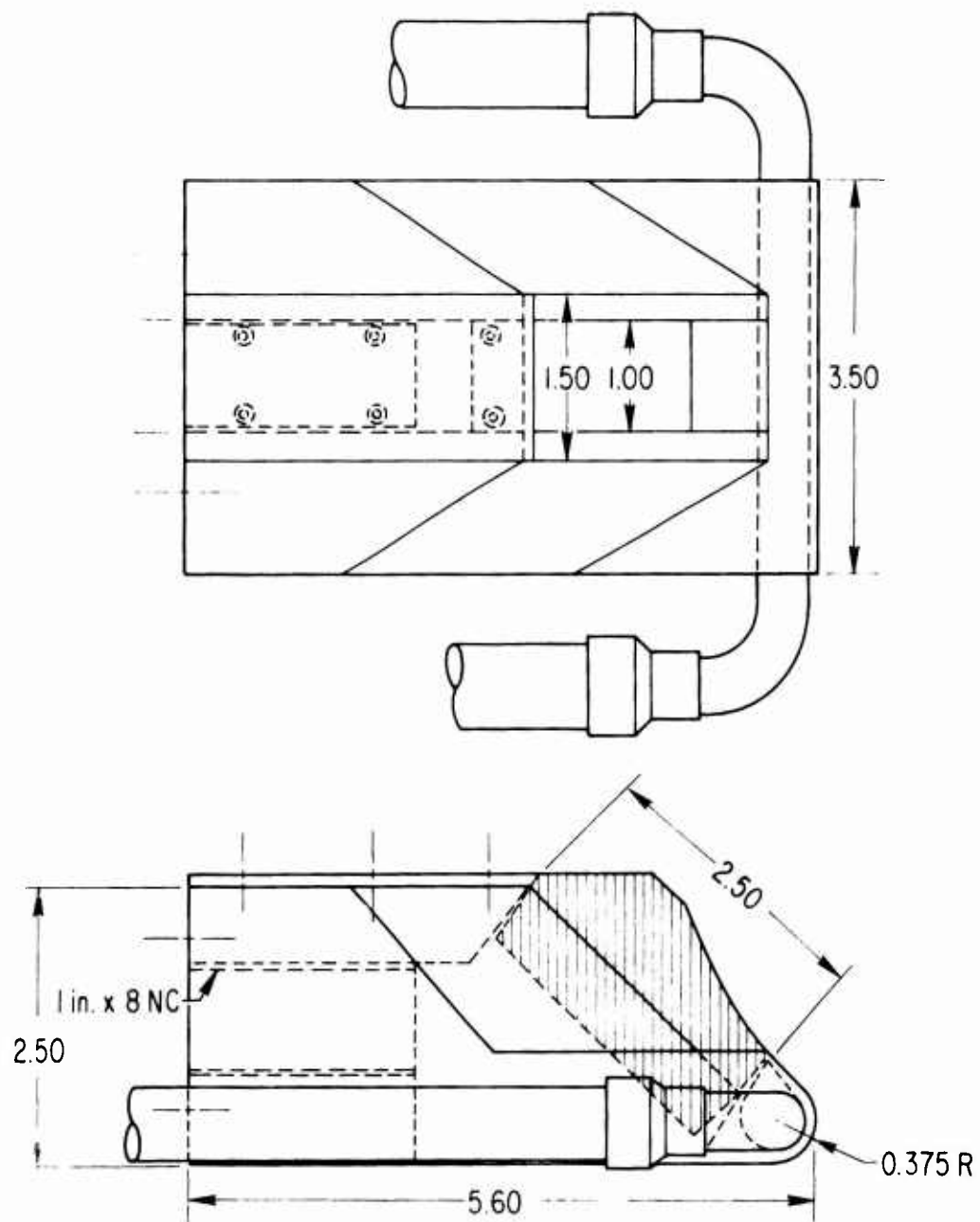

Figure 1. Water-Cooled Holder Configuration

III. MODEL DEVELOPMENT

Following a recommendation by Tate,¹ we decided to start with the standard 45-deg wedge model with a water-cooled leading edge (Fig. 1) and attempt to contour the model surface to obtain constant pressure gradients. This wedge has a number of advantages: it has a large surface area, 1.5 in. wide \times 2.0 in. long; mounting the specimen so that the 1.5-in. dimension is vertical nullifies the effect of asymmetries in the flow field and enhances the conditions on the model; the wedge has a fixed leading edge.

During wedge tests, the flow is stagnated on the water-cooled leading edge of the specimen holder. The gas flows from this region over the specimen. If the pressure is constant or decreasing, the shock systems are weak and the flow over the specimen is nearly isentropic. In this case, the holder stagnation pressure is also the total pressure of the flow over the specimen, and the ratio of measured local static pressure to holder stagnation pressure yields the local Mach number through the isentropic flow relationship. The total enthalpy of the flow outside the boundary layer is constant, since heat is lost only in the thin boundary layer. From the local pressure distributions presented in the following sections, the rest of the flow conditions over the specimen can be calculated. The total conditions of the flow from the rotor, the holder stagnation conditions, and static conditions 0.5 in. from the specimen leading edge are presented in Table 1.

Our first attempt was to develop a constant-pressure model. In order to minimize the pressure gradient, we used two methods to calculate a curvature for the specimen. One method is a weak-shock-wave solution technique based on the Prandtl-Meyer turning angle; it is described in the Appendix. The other is a strong-shock-wave solution, which incorporated modified Newtonian theory. Both methods make maximum use of flow field calibration data and the 45-deg flat wedge pressure distribution obtained in earlier programs.

We obtained a reasonably high pressure over a long test surface by setting the initial angle of the specimen at 35 deg, with the model holder stagnation

point 0.5 in. from the rotor. The constant-pressure contours calculated by the Prandtl-Meyer and modified Newtonian methods were significantly different, and a compromise contour, halfway between the two calculated contours, was selected for the first calibration model (Fig. 2). Solid copper calibrating

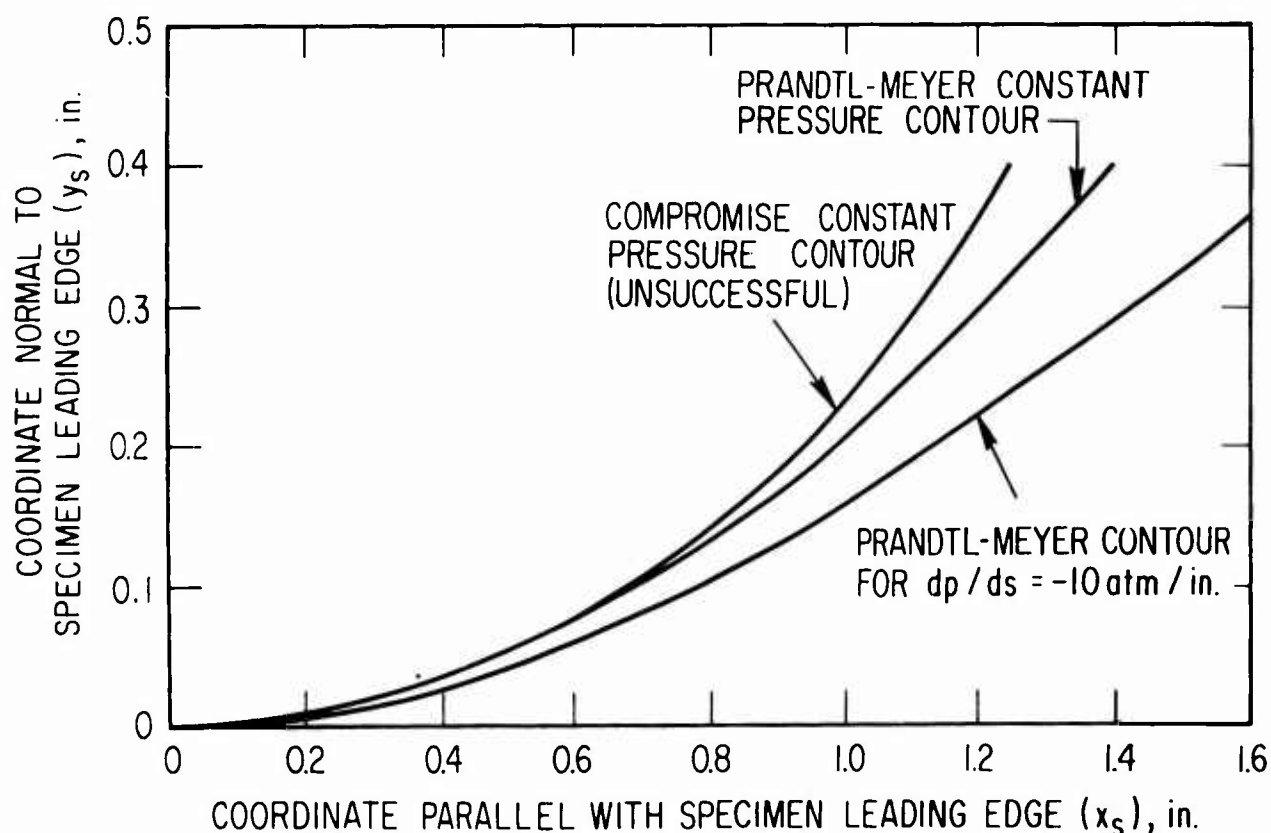

Figure 2. Comparison of the Model Contours

models were instrumented with both calorimeters and pressure ports, as shown in Fig. 3 and Fig. 4, which is a photograph of a mounted model. A cap consisting of two 1/8-in.-thick strips of Teflon was wrapped around the holder and model and fastened to the top and bottom. This cap was used to delay model heating until the flow had become established. The pressure distribution obtained from this model is shown in Fig. 5. The centerline pressures seem to indicate an overexpansion near the leading edge and a strong recompression toward the aft portion of the model. The initial overexpansion was not well

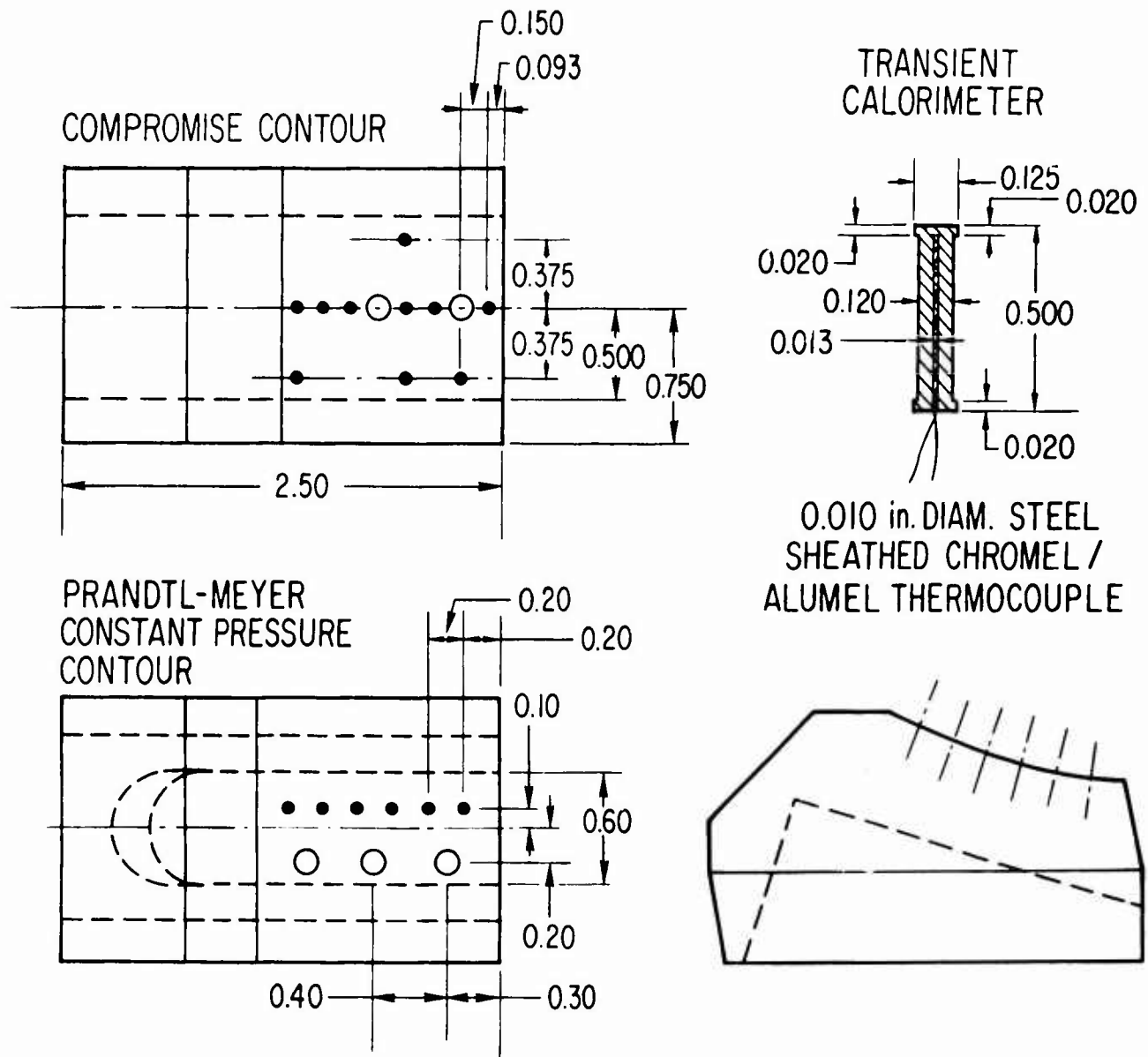

Figure 3. Calibration Model Instrumentation

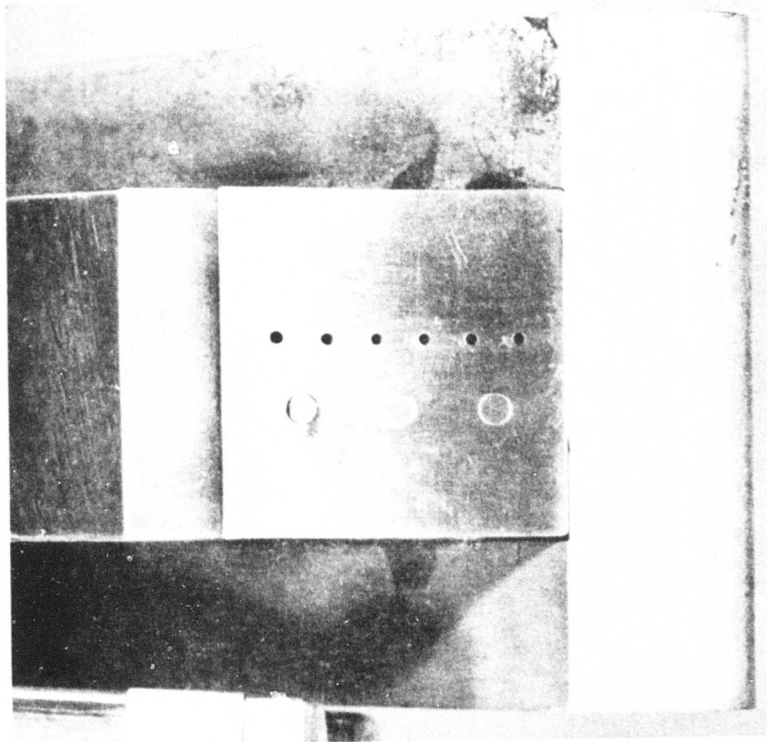

Figure 4. Typical Calibration Model

defined, because its presence was indicated by only one pressure, which may have been influenced by the presence of the calorimeter immediately ahead of it. However, the well defined recompression indicated that the contour was too steep.

The shallower contour calculated by the Prandtl-Meyer method was selected for the second attempt at a constant-pressure model. Tolerances on the second model were held to limits used for hypersonic throats, and test surface coordinates were within 0.005 in. of the designated coordinates. In addition, the calorimeters and pressure taps were moved to separate rows to reduce any possible interactions (Fig. 2). This model generated a nearly constant pressure distribution, as shown by the dashed curve in Fig. 6, although the pressure level was about 25 percent higher than expected. Motion picture examination revealed that the jet from the rotor caused the model to move about 0.4 in. and rotate about 5 deg. The rotation increased the angle of attack of the

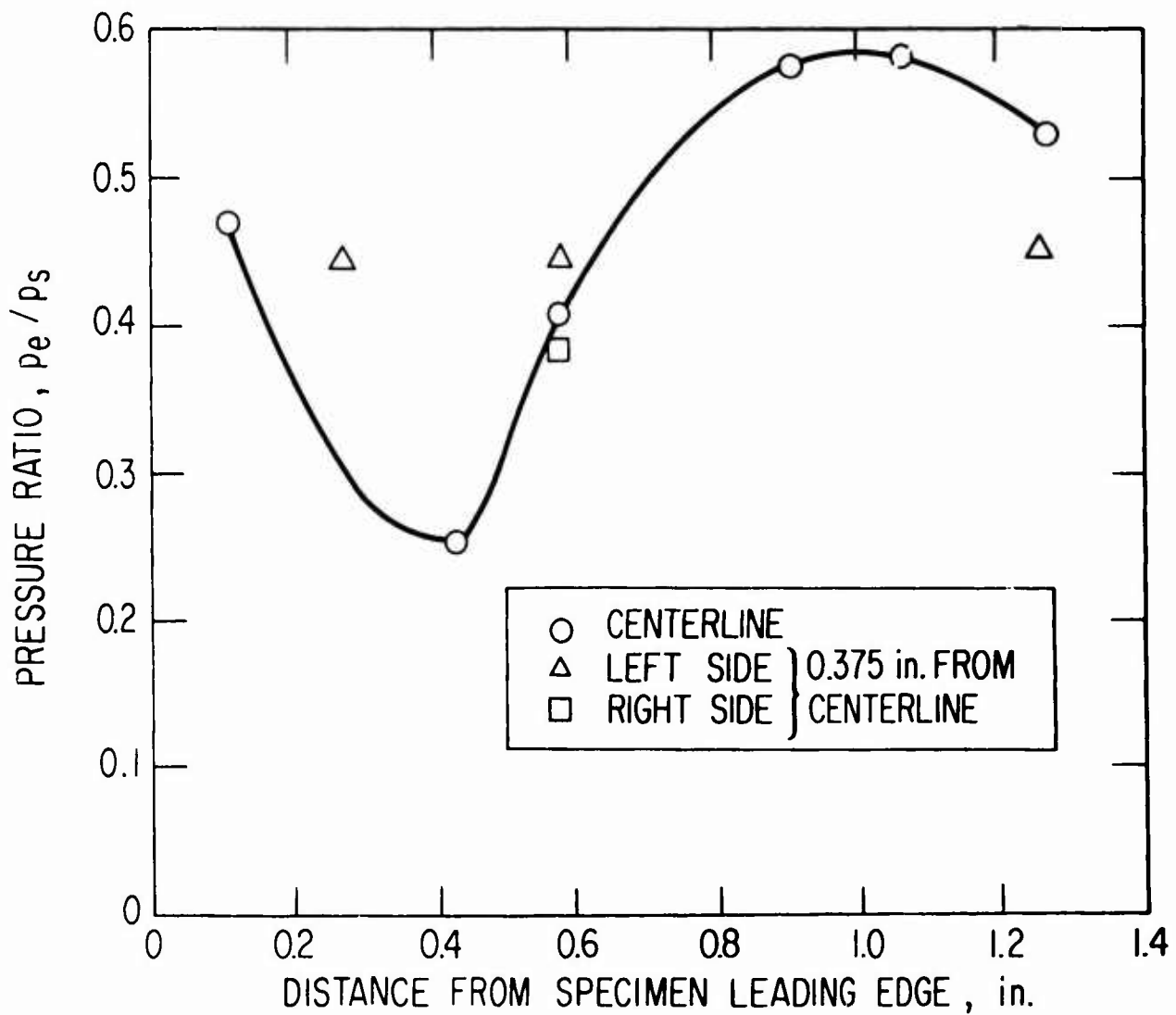

Figure 5. Pressure Distribution from the Compromise Contour

surface, thus increasing the pressure. Also, the lateral movement caused the jet to impinge on the inclined surface without stagnating at the geometrical stagnation point of the holder, which may have contributed to the high pressure. Two additional models generated pressures of the same level as those predicted by the calculations. These measured distributions are presented in Fig. 6.

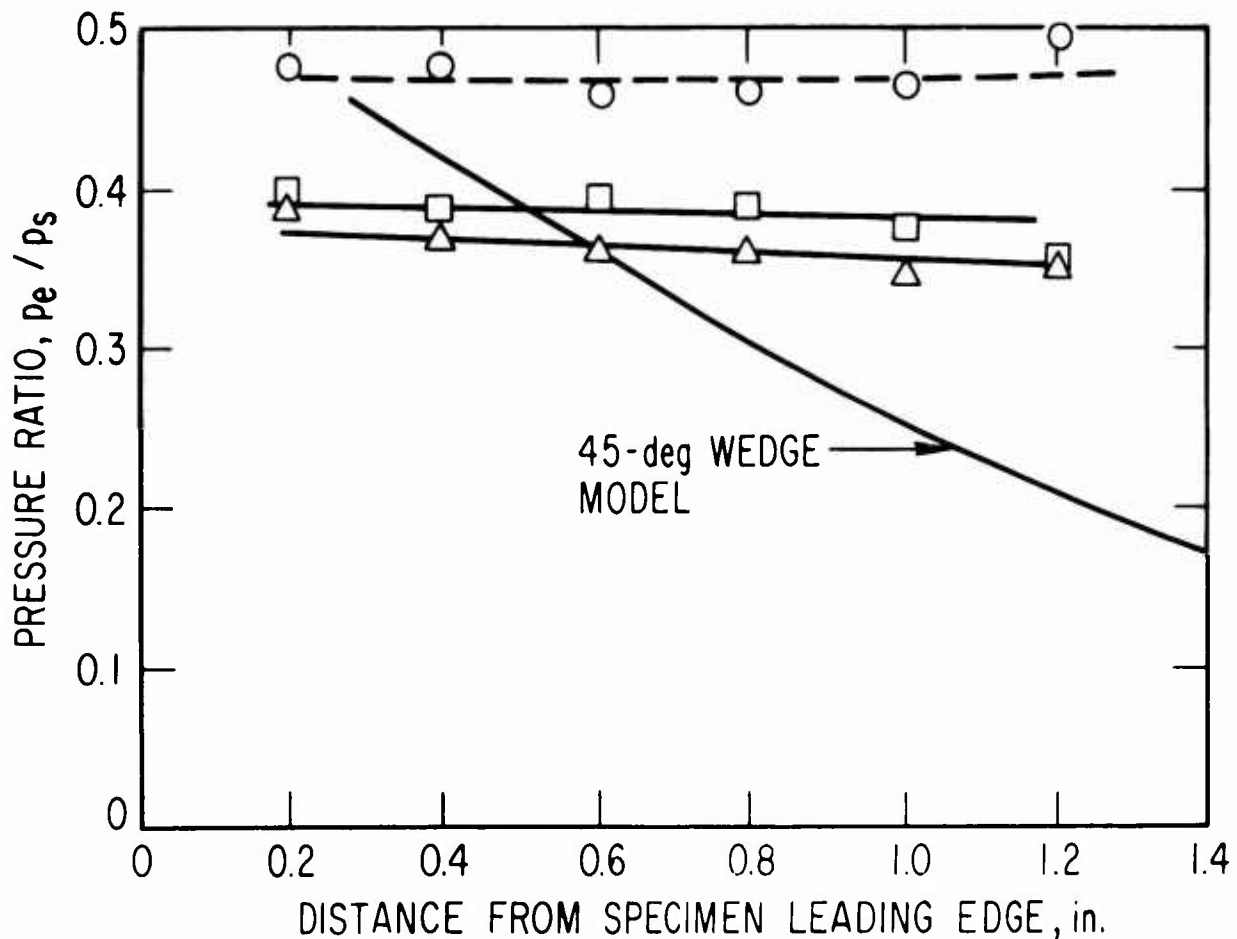

Figure 6. Pressure Distributions on the Prandtl-Meyer Constant-Pressure Contour

The Prandtl-Meyer method was then used to generate a contour to create a pressure gradient of -10 atm/in. The leading edge angle was increased from 35 to 40 deg to bring the average surface pressure close to the level generated on the constant-pressure surface. The pressure distribution was not quite smooth, but the average gradient over the sample length was very close to -10 atm/in., as shown in Fig. 6.

Pressure distributions along the flat 45-deg wedge, which were obtained in previous studies,² are also shown in Fig. 6. All pressures shown in this figure have been normalized with the wedge holder stagnation pressure, which is the effective total pressure for the flow adjacent to the sample. The

normalized pressure allows direct calculation of the local Mach number and the other local flow parameters.

Heat flux data for the two contoured and flat configurations are presented in Fig. 7. The data for the constant pressure contour represent an average of data obtained during the three runs when the pressure gradient was close to zero, and the data for the flat wedge represent an accumulation of previous data.² Data for the three configurations are reasonably close to the prediction of turbulent boundary layer theory for a flat plate, with the distance parameter measured from the water-cooled holder stagnation point. Aerodynamic shear stress, calculated from the Reynolds analogy, is also shown in Fig. 7.

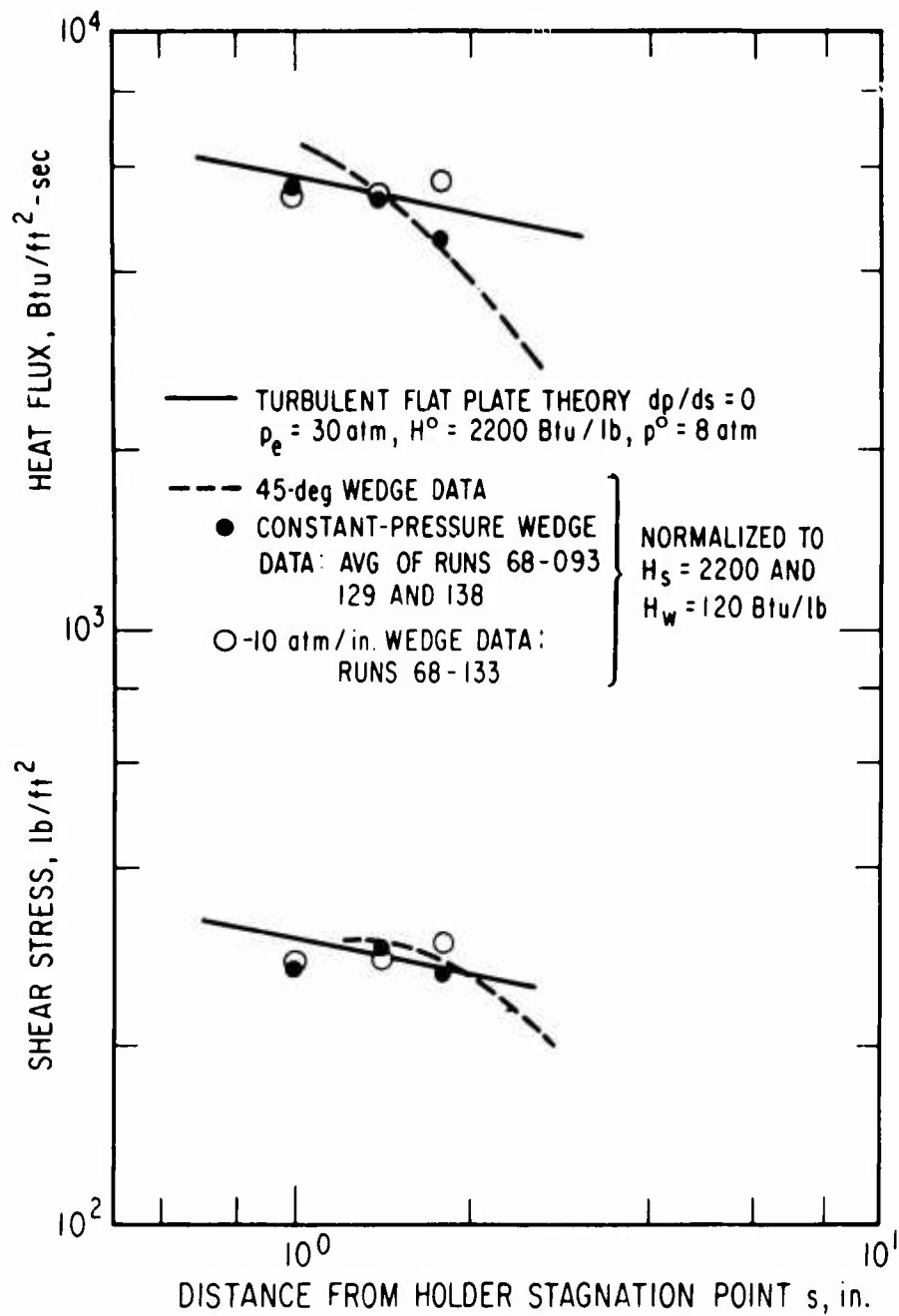

Figure 7. Heat Flux and Shear Stress Distributions

IV. ABLATION TESTING

In order to test the usefulness of these new contoured models, we planned a series of ablation runs using a REST 6300 HP composite. This material, developed under a SAMSO contract for the REST program, has been extensively characterized and tested. It has been used as a standard under the RESEP program for the past few years. The specimens prepared for this program contained 44 percent Monsanto SC1008 phenolic and 56 percent 3M Pluton B-1 high purity fabric and were substantially within the specification for this material developed under the REST program. All specimens were cut from a flat laminate 4 in. thick and approximately 1 ft square. The standard 45-deg wedges were cut to a fabric orientation angle of 30 deg to the surface away from the direction of flow. Since both contoured models (0 and 10 atm/in. pressure gradients) could not be cut to a constant fabric orientation, an average orientation of about 30 to 35 deg at the midpoint (fore to aft) was selected. Copper adaptor blocks were designed as shown in Fig. 8 to accommodate the contoured specimens to the 45-deg wedge model holder.

Environmental conditions and specimen performance data are listed in Table 2. The most striking data are those for total recession. For all three configurations at the point of maximum recession, the amount of erosion is the same. The constant-pressure, constant-heat-flux model eroded uniformly over its entire surface, as was expected. A comparison of the initial and final contours of this model with those of the 45-deg wedge is shown in Fig. 9. The very high recession rate in the absence of any significant pressure gradient shear is most surprising. Inspection of film taken during the runs, at 600 frames/sec, shows very definitely that char particles, some of them quite large, are being removed by what appears to be some mechanical process. It is interesting to note that the 45-deg flat wedge model, as it ablates, tends to be the same shape as the constant-pressure contoured models. Under the REST program (Ref. 7) copper calibration models furnished with pressure ports were made to mockup the shapes produced as the model ablated. At the point of maximum recession, the local pressure rose rapidly to the same local pressure as

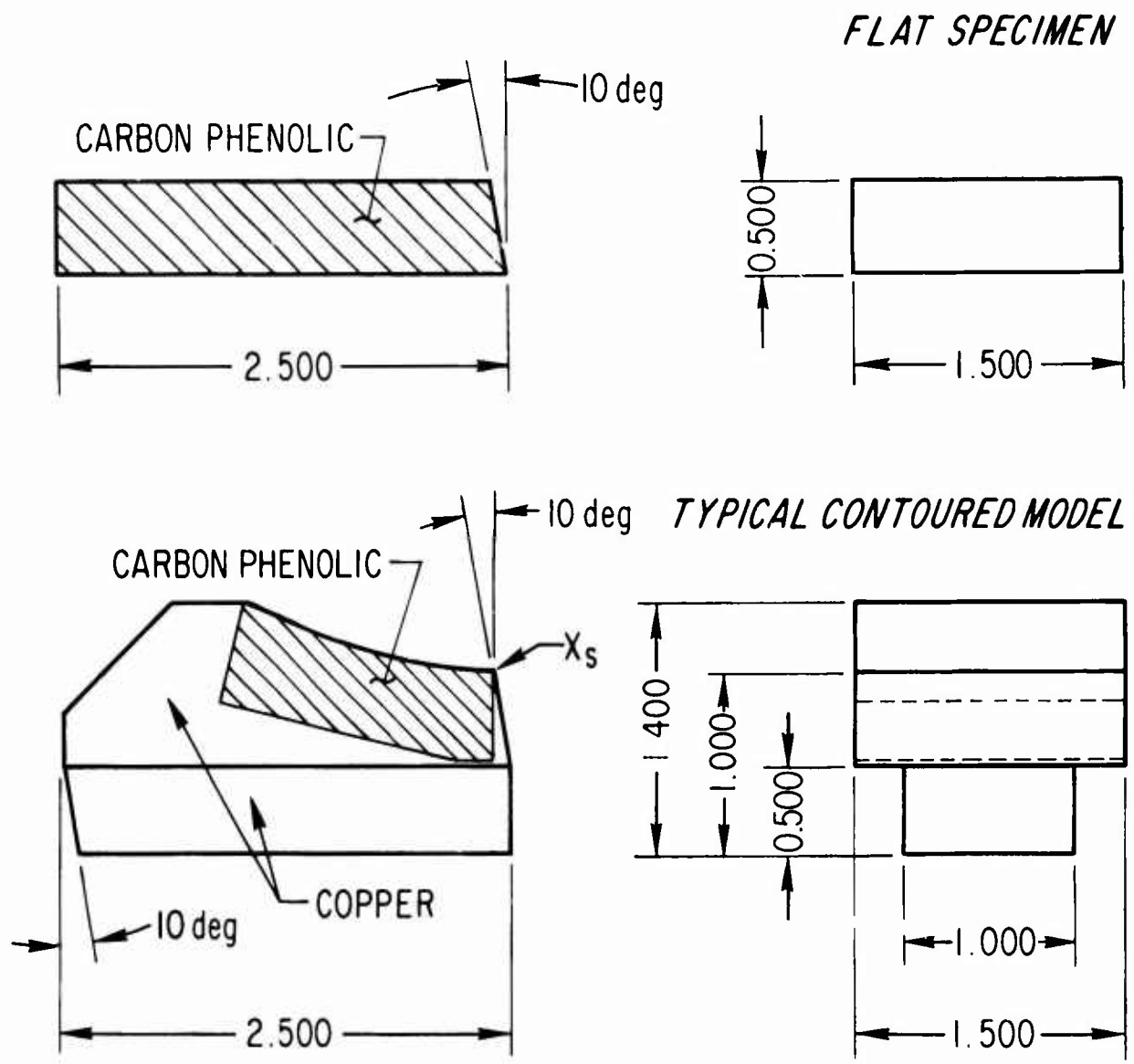

Figure 8. Configurations of Wedge Models

Table 2. Typical Test Data for Standard Carbon Phenolic

Model No.	1	2	3
Configuration	Flat Wedge	dp/ds = 0 atm/in.	dp/ds = -10 atm/in.
α , deg	45	35	40
X Station, in.	0.5	0.5	0.5
t_i , sec	0.73	1.02	0.83
t (Run Time), sec	1.77	1.58	1.62
Specimen weight, g			
Before	42.31	28.30	30.50
After	26.80	16.85	17.50
Max. Recession, in.	0.2545	0.2531	0.2644
Location of Max. Recession x_s , in.	0.6	Uniform	0.8
Avg. Surface Temp., °R			
$x_s = 0.5$ in.	5800	5800	5800
$x_s = 1.0$ in.	5500	5650	5650

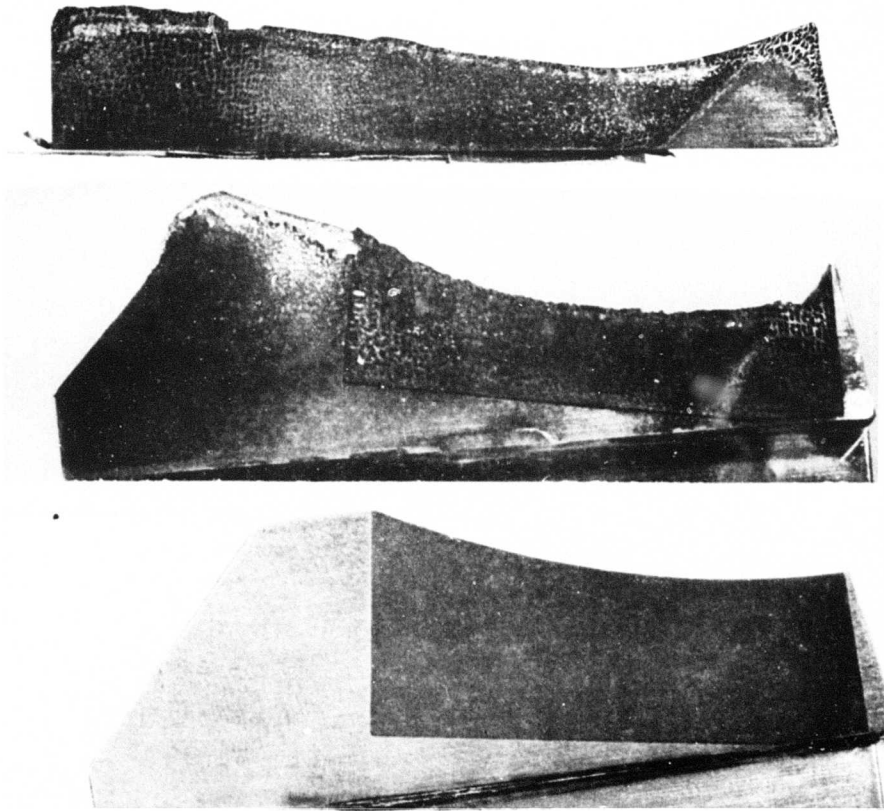

Figure 9. Comparison of Contoured Ablation Specimen and Flat Specimen

that which occurs over most of our constant pressure model (~ 30 atm). The recession rates of both the 0-atm/in. model and the 20-atm/in. model were constant during the entire run and were equal where the local pressures were equal. These data indicate that the recession correlates more with local pressure than with pressure gradient.

V. CONCLUSIONS

Ablation models with relatively large surface areas can be designed, with the use of the Prandtl-Meyer turning angle technique, to give constant pressure gradients in the CAL wave superheater. For the case where the pressure gradient is zero, the heat flux is also a constant. In this case, the aerodynamic shear stress as calculated from the Reynolds analogy is also constant.

For the limited amount of ablation testing performed with a standard R6300 HP carbon phenolic, high ablation rates with apparent mechanical removal occur, even on a zero-pressure-gradient model. A comparison of this specimen with a 45-deg, 20-atm/in.-pressure-gradient model at the point of maximum recession appears to correlate recession rate with local pressure rather than with pressure gradient.

REFERENCES

1. Johnson, G. P., Arne, C. L., and Yano, D. M., "Maneuvering Reentry Control and Ablation Studies (MARCAS), Final Report," Rept. BSD-TR-65-312, 1965, Douglas Aircraft Co., Santa Monica, Calif.
2. Bishop, W., and Di Cristina, V., CAL Wave Superheater Cone and Wedge Ablation Test Results, RAD-TM-65-44, October 1965, Avco Corp., Wilmington, Mass.
3. "Semi-Annual Report, Reentry Systems Environmental Protection (RESEP) Program, Task II - High Performance Heat Shields," Rept. L-78-67-2 (BSD-TR-67-184), April 1967, Lockheed Missiles and Space Co., Sunnyvale, Calif.
4. Schneider, P. J., Dolton, T. A., and Reed, G. W., "Char-Layer Structural Response in High Performance Ballistic Reentry," Paper 66-424, 1966, AIAA.
5. Bishop, W. M., "An Experimental Study of Ablation Materials Under High-Shear Environments" Rept. AVMSD-0178-66-CR (BSD-TR-66-308), 23 Sept. 1966, Avco Corp., Wilmington, Mass.
6. Fisher, E. B., "Design and Test of Contoured Wedge Ablation Models in the CAL Wave Superheater Test Facility," Rept. AA-2527-Z-1, September 1968, Cornell Aeronautical Lab., Buffalo.
7. Graves, K. W., "Ablation of Composite Materials for the REST Program Phase I," Rept. AA-2211-W-1, May 1966, Cornell Aeronautical Lab., Buffalo.

APPENDIX. DESIGN PROCEDURE FOR A CONTOURED
WEDGE WITH AN ARBITRARY PRESSURE GRADIENT

There are three basic steps in the procedure for generating a wedge contour for use in the wave superheater free jet. These are problem specification, model orientation, and the actual calculation of the contour. The first of these, the problem specification, includes such items as pressure level, pressure gradient, type of material to be tested, and model size. Several parameters should be considered before the model is designed. Obviously, the highest model pressures can be obtained if the wedge configuration is positioned close to the rotor. However, in many cases the same surface pressure can be obtained at different test locations. The stagnation pressure on the wedge holder leading edge is the effective total pressure of the flow over the wedge. As the holder is moved farther from the rotor, the stagnation pressure decreases, and the holder incidence angle must be increased to maintain the same static pressure over the surface. The increased incidence angle results in reduced Mach number, heat flux, and shear stress. Therefore, specification of surface pressure alone is not sufficient to define the contour.

Once the problem has been properly specified, the next task is to pick a rotor station and determine the initial angle of the sample necessary to generate the correct pressure at the leading edge. This angle is determined by generating an expression for the pressure distribution over a flat wedge with the same angular orientation. Since calibration data are limited to 45-deg wedges at a few stations from the rotor, this distribution is not known a priori. It is assumed that the static pressure distribution in the free stream is representative of the distribution over a 0-deg wedge configuration. This pressure distribution is written in the form

$$p_e = a p_s e^{-bx}$$

where a and b are constants, p_s is the stagnation pressure on the wedge holder, and x is the distance from the rotor. The measured or interpolated pressure distribution over a 45-deg wedge is converted into a similar expression. It should be reiterated that p_s is also the total pressure of the flow over the wedge surface and that p_e/p_s specifies the local Mach number. For the cases considered to date, the exponent b is nearly the same for both the 0-deg and the 45-deg wedges. The desired pressure at the wedge leading edge has been specified, p_s is determined by specifying the distance from the rotor, and the constant a can be determined. The variation of a is assumed to be linear with angle from 0 to 45 deg, and the initial angle of the specimen is obtained through linear interpolation. When the angle is known, the constant b can be corrected for the small difference between 0 and 45-deg wedges, if necessary, and the calculation repeated. The initial angle should be checked for consistency with the problem specifications. At this point, the flow conditions at the sample leading edge and the distributions on a flat wedge with the same leading edge angle are known.

The next step involves the actual mechanics of generating the contour coordinates. Simply stated, the Mach number distribution on the flat wedge and the required Mach number distribution according to the specified pressure gradient are computed. Then the Prandtl-Meyer angles for both distributions are generated. The local angles of the flat wedge are modified by the difference between the specified and the flat wedge Prandtl-Meyer angles, and the contour coordinates are obtained by a finite-difference-type procedure. The step-by-step calculation procedure is as follows

1. Select a nominal value for Δx
2. Compute x for each value of Δx .
3. Compute the flat wedge values for $p_e/p_s = ae^{-bx}$, $M_e = f(p_e/p_s)$, $v_e = f(M_e)$, and $\Delta x_s = \Delta x / \cos \theta_0$ for each value of x . v is the Prandtl-Meyer function, and a calculation method for real gas is given by Owczarek.¹

¹Owczarek, J. A., Fundamentals of Gas Dynamics, International Textbook Company, Scranton, Pa., 1964.

4. Compute $\Delta y_s = \Delta x_s \tan(\theta_{j-1} - \theta_0)$ where j is the calculation index; i.e., $j = 0$ at the sample leading edge and $j = 1$ at the end of the first Δx_s increment.

5. Compute $\Delta s_j = \sqrt{\Delta x_s^2 + y_s^2}$

6. Compute the specified pressure:

$$(p_{\text{spec}}/p_s)_j = (p_e/p_s)_{j=0} + \frac{dp}{ds} \left(\sum_{j=1}^j \Delta s_j \right)$$

7. Compute specified Mach no. using real gas functions:

$$M_{\text{spec } j} = f(p_{\text{spec}}/p_s)_j$$

8. Compute the specified Prandtl-Meyer function:¹

$$v_{\text{spec } j} = f(M_{\text{spec } j})$$

9. Compute the new wedge angle:

$$\theta_j = \theta_0 + (v_{ej} - v_{\text{spec } j})$$

10. A slight error is incorporated in Step 4 when θ_{j-1} , the angle of the previous element, is used as the angle of the j th element. This error is usually small if Δx is small, but it can be eliminated for all practical purposes by use of an average angle:

$$\Delta y_s = \Delta x_s \tan[(\theta_j + \theta_{j-1})/2 - \theta_0]$$

Repeat Steps 3 through 9 to obtain the more accurate value for θ_j .

11. Update the j index and start from Step 4 again. Follow this procedure until the computed value of $\Delta s = \sum \Delta s_j$ exceeds the specified model length or the value of θ_j exceeds 90 deg.
12. The final coordinates of x_s and y_s should be smoothed, since the contour is as sensitive to bumps as is the throat region of a contoured hypersonic nozzle.

UNCLASSIFIED

Security Classification

DOCUMENT CONTROL DATA - R&D		
<i>(Security classification of title, body of abstract and indexing annotation must be entered when the overall report is classified)</i>		
1 ORIGINATING ACTIVITY (Corporate author) The Aerospace Corporation El Segundo, California		2a REPORT SECURITY CLASSIFICATION Unclassified
		2b GROUP
3 REPORT TITLE Design and Testing of Ablation Models with Controlled Pressure Gradients		
4 DESCRIPTIVE NOTES (Type of report and inclusive dates)		
5 AUTHOR(S) (Last name, first name, initial) Barry, William T., and Fisher, Edward B.		
6 REPORT DATE 69 FEB 28	7a TOTAL NO OF PAGES 28	7b NO OF REFS 7
8a CONTRACT OR GRANT NO FO4701-68-C-0200	9a ORIGINATOR'S REPORT NUMBER(S) TR-0200(4250-40)-7	
b PROJECT NO	9b OTHER REPORT NO(S) (Any other numbers that may be assigned this report) SAMSO-TR-69-187	
c		
d		
10 AVAILABILITY/LIMITATION NOTICES This document has been approved for public release and sale; its distribution is unlimited.		
11 SUPPLEMENTARY NOTES	12 SPONSORING MILITARY ACTIVITY Space and Missile Systems Organization Air Force Systems Command United States Air Force	
13 ABSTRACT Studies of high-pressure ablation mechanisms have been hampered by lack of suitable ablation models. A technique has been developed to contour wedge models for testing in the Cornell Aeronautical Labs. wave superheater to give either a constant pressure, a constant heat transfer, or a constant pressure gradient up to the limit of the facility. Preliminary testing with a standard carbon phenolic composite shows that high recession rates occur even in the absence of a significant pressure gradient.		

Ablation
Recession rates
Wedge models

Abstract (Continued)