

ASD-TR-69-9

AD695473

**BAK-14/F32 RETRACTABLE CABLE SUPPORT
SYSTEM**

ALEX V. WOLFE, 1st LIEUTENANT, USAF

TECHNICAL REPORT ASD-TR-69-9

AUGUST 1969

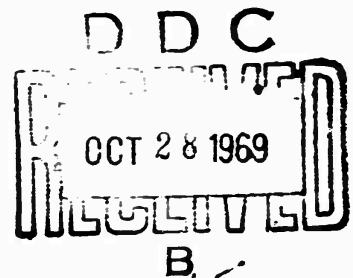

This document has been approved for public release and sale;
its distribution is unlimited.

DEPUTY FOR ENGINEERING
AERONAUTICAL SYSTEMS DIVISION
AIR FORCE SYSTEMS COMMAND
WRIGHT-PATTERSON AIR FORCE BASE, OHIO

Reproduced by the
CLEARINGHOUSE
for Federal Scientific & Technical
Information Springfield Va. 22151

16

NOTICE

When Government drawings, specifications, or other data are used for any purpose other than in connection with a definitely related Government procurement operation, the United States Government thereby incurs no responsibility nor any obligation whatsoever; and the fact that the government may have formulated, furnished, or in any way supplied the said drawings, specifications, or other data, is not to be regarded by implication or otherwise as in any manner licensing the holder or any other person or corporation, or conveying any rights or permission to manufacture, use, or sell any patented invention that may in any way be related thereto.

This document has been approved for public release and sale; its distribution is unlimited.

ACCESSION BY	
INFO	WRITE SECTION <input checked="" type="checkbox"/>
DOC	DUFF SECTION <input type="checkbox"/>
UNAPPROVED	<input type="checkbox"/>
JUSTIFICATION	
BY	
DISTRIBUTION AVAILABILITY CODES	
DIST.	AVAIL. and SPECIAL
1	

Copies of this report should not be returned unless return is required by security considerations, contractual obligations, or notice on a specific document.

ASD-TR-69-9

**BAK-14/F32 RETRACTABLE CABLE SUPPORT
SYSTEM**

ALEX V. WOLFE, 1st LIEUTENANT, USAF

**This document has been approved for public release and sale;
its distribution is unlimited.**

ASD-TR-69-9

FOREWORD

This report was initiated by the Equipment Development Branch, Delivery and Retrieval Division, Directorate of Crew and AGE Subsystems Engineering of the Deputy for Engineering, Aeronautical Systems Division, Wright-Patterson Air Force Base, Ohio. This organization and the Federal Aviation Administration, National Aviation Facilities Experimental Center conducted the test program. Captain Robert L. Hazlett (ASNMH-10) initiated program documentation, Lt Alex V. Wolfe (ASNMH-10) was the USAF project engineer, and Mr. Hugo P. Scheuerman (NA-541) was the FAA project engineer. The Aeronautical Systems Division provided test authority under Engineering Service Project Card (ESP) 921A-9269, dated 4 March 1966. The Erlandsen Corporation (TEC) of Maine designed and installed the system under Air Force contract AF 41(608)-39783.

The tests were conducted at the National Aviation Facilities Experimental Center (NAFEC), Atlantic City Airport, New Jersey, between 30 September 1966 and 3 October 1968.

This report was submitted by the author February 1969.

This technical report has been reviewed and is approved.

W. P. Shepardson

WARREN P. SHEPARDSON
Chief, Delivery and Retrieval Division
Directorate of Crew and AGE Subsystems
Engineering

ABSTRACT

This report presents the result of a development and test program to evaluate the BAK-14/F32 Retractable Cable Support System and all of its components. A total of nine rollovers and twenty successful engagements were accomplished using the F-100, F-101, F-106, and A-4D aircraft.

The objectives of the program were to:

- a. Determine the engaging reliability with aircraft arresting hooks.
- b. Analyze the restraint characteristics of the support blocks when aircraft touch down on the cable.
- c. Prevent damage to private and commercial aircraft during rollover.

The test results demonstrated that the BAK-14 was compatible with the BAK-9 arrestor and that the BAK-14 concept was compatible with all arrestors which utilize cross-runway cables. The test results also indicated that the system could be engaged bidirectionally with equal reliability.

The installation was comprised of 24 identical cable support boxes, each separated by eight feet. In operation, when the system was retracted, the control tower or runway edge operator actuated an electrical valve which permitted high pressure air to be ducted into the air cylinder of each support box forcing the special forked arm, linking the spring-arm assembly and the air cylinder, to twist the torsion spring such that it retracted the cable into a cross-runway slot in approximately eight seconds. When the system was raised, the three-way valve was opened and air was released to the atmosphere causing the fork fitting to withdraw into the air cylinder, and the torsional spring returned the spring-arm assembly to the raised position in approximately five seconds.

TABLE OF CONTENTS

SECTION	PAGE
I INTRODUCTION	1
1. General	1
2. Historical Background	1
II TEST PROGRAM	4
1. Test Objectives	4
2. Test Program	4
3. Instrumentation and Photographic Coverage	6
III DESCRIPTION AND OPERATION OF EQUIPMENT	7
IV TEST RESULTS	21
1. Engagement and Spin-Up Tests	21
2. Recycling Tests	25
3. Drainage Tests	26
4. Thermostatic Heater Tests	26
5. Control Tower Equipment Tests	27
6. Civil Aircraft Tests	27
V FUNCTIONAL ANALYSIS	29
1. Cable Support Blocks	29
2. Electrical System	41
3. Position Indicating Switches	42
4. Down Bumpers	42
5. Missed Engagements	44
VI CONCLUSIONS	49
VII RECOMMENDATIONS	50
APPENDIX I Retractable Cable Support Test Data	53
APPENDIX II Static Test Of Support Blocks	55
APPENDIX III Static Test Of Polyurethane Support Block	65

ILLUSTRATIONS

FIGURE	PAGE
1. Standard Donut Cable Supports in a Runway Groove	3
2. Test Runway at NAFEC	5
3. Arresting Cable in Raised Position with Slotted System	8
4. Arresting Cable Retracted into Cross-Runway Slot	9
5. Arresting Cable Retracted onto Runway Surface	10
6. Schematic Sketch of Cable Support Box	11
7. Type A Cable Support Block	14
8. Type B Cable Support Block	15
9. Type C Cable Support Block	16
10. Retracted Type B Cable Support Block	17
11. Type C Block After Heavy Aircraft Spin-Up	18
12. Sketches of Support Blocks	30
13. Off-Center Characteristics of BAK-14	32
14. Determination of Cable Throwing Action	34
15. Schematic Sketch of Cable Support Block	35
16. Schematic Sketch of Cable Being Fulled from Block	36
17. Type B with Separated Base Plate	37
18. Type B Support with Fatigue Crack	39
19. Type B Support Damaged by F-106 After 120 Knot Engagement	40
20. Various Stages of Down Bumper Deterioration	43
21. Striker Plate of Spring-Arm Assembly	45
22. F-106 Hook After Missed Engagement	46
23. Damaged and Undamaged Wear Plates	48
24. Static Test Set-Up	56

ASD-TR-69-9

ILLUSTRATIONS (Cont'd)

FIGURE		PAGE
25.	Deflection Curve for Slit Type A Support Blocks	57
26.	Deflection Curve for Unslit Type A Support Blocks	58
27.	Deflection Curve for Slit Type B Support Blocks	59
28.	Deflection Curve for Unslit Type B Support Blocks	60
29.	Deflection Curve for Slit Type C Support Blocks	62
30.	Deflection Curve for Unslit Type C Support Blocks	63
31.	Deflection Curve for Polyurethane Type C Support Blocks	66

SECTION I

INTRODUCTION

1. GENERAL

The purpose of this test program was to evaluate a retractable cable support system as designed, installed, and maintained by The Erlandsen Corporation (TEC) of Maine in order to determine its suitability for eventual use with arresting systems installed upon active runways. The tests were conducted on runway 13-31 at the National Aviation Facilities Experimental Center (NAFEC), Atlantic City Airport, Pomona, New Jersey from 30 September 1966 to 3 October 1968. This report presents the results of these tests and an in-depth study of a system designated as the BAK-14/F32 Retractable Cable Support System.

Test authority was provided under the Aeronautical Systems Division (ASD) Engineering Service Project Card (ESP) 921A-9269, dated 4 Mar 1966. ASD and FAA managed the program and provided engineering and operational support. The Aerospace Defense Command (ADC), Air National Guard (ANG), and the Naval Air Test Facility (NATF) provided test aircraft and pilots to support the program.

2. HISTORICAL BACKGROUND

ADC and ANG are pursuing a dispersal program which entails deployment of fighter aircraft to civil airports. In general, runways at these fields are short and will not support fighter operations without barrier protection. The Atlantic City Airport, one of these dispersal fields, is equipped with a standard BAK-9/F48A aircraft arresting system. As the runway does not have paved overrun areas, the two arresting systems have been installed at each end on the active runway. Spaced rubber donuts are used to hold the cable above the runway surface. The barrier locations at 2,300 feet and 1,000 feet from each end have caused some difficulty to pilots operating private and commercial aircraft from the runway. There has been minor damage to gear doors and other protuberances on the aircraft as a result of contacting the cable during landing and takeoff.

The donut supported cable has created a severe maintenance problem in that the donuts had to be adjusted or replaced daily. Whenever an aircraft rolled over the cable it would be forced down to the runway surface with such an impact that a 1 1/4 inch deep groove (Figure 1) was worn into the pavement during a six month period. In turn, these rollovers necessitated cable replacement every two weeks. This is a common problem at all bases which have heavy traffic over arresting cables located on the active runway, especially at bases in Southeast Asia (SEA). With this situation it is highly probable that one of the following conditions will occur:

(a) a missed engagement will result because cable dynamics could force the pendant into the groove as the tailhook passes, or

(b) cable failure could result because the leading edge of the hook shoe could squarely impact the pendant on the edge of the groove, thus failing the cable or at least severely weakening it, causing it to fail during the arrestment. The standard donut cable supports (Figure 1) are primarily used throughout the Air Force. To simplify the increasing number of approach end engagements, these supports are generally being installed from 1,000 to 2,000 feet upon the active runway. At these installations damage to runways and aircraft rolling over the cables is frequent.

The problems of runway damage, cable damage, aircraft damage, and increased probability of a missed engagement have created a need for a system which could be retracted onto or under the runway. Therefore, USAF jointly conducted a program with FAA to develop such a system.

The request for proposals prescribed that the pendant (cable) would be supported by blocks made of rubber or other frangible material, spaced at intervals across the runway which would be sufficient to maintain a minimum pendant height of 2 1/2 inches above the pavement. The equipment had to be capable of being retracted when not in use so that it would not interfere with light aircraft, runway-sweeping equipment, and snow-removal operations. The supports also had to be fail-safe so that in the event of a power failure or other malfunction, the supports would automatically raise the cable, ready for an engagement.

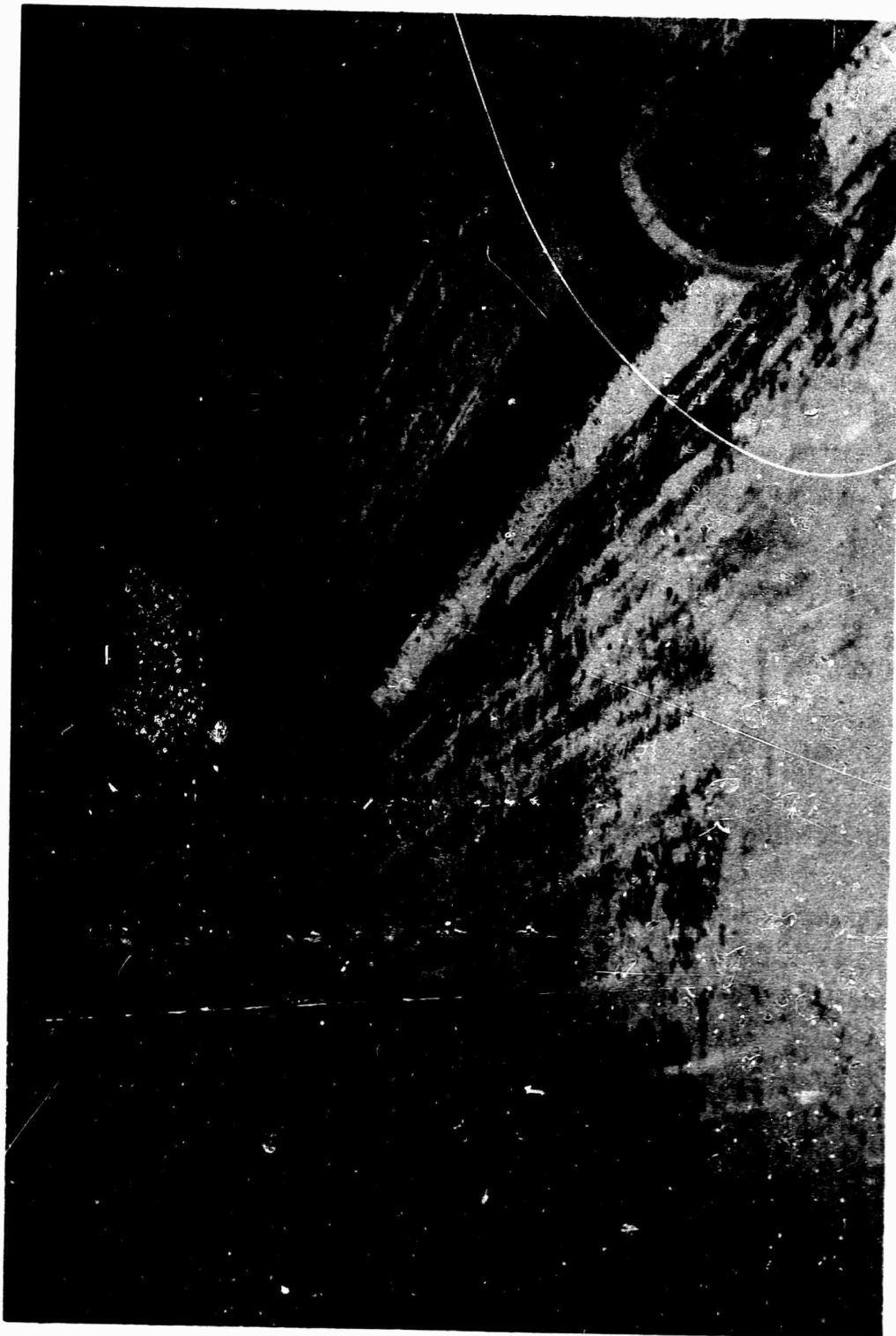

Figure 1. Standard Donut Cable Supports in a Runway Groove

SECTION II

TEST PROGRAM

1. TEST OBJECTIVES

The objectives of the test program were to:

a. Verify that the retractable cable support system, in the raised position, would adequately support an arresting pendant for successful engagement by aircraft arresting hooks.

b. Verify that the retractable cable support system, in the retracted position, would adequately restrain the arresting pendant to prevent:

- (1) Damage to private and commercial aircraft during rollover.
- (2) Damage to the cable which impacts on the runway due to the spin-up of landing aircraft wheels (spin-up can be defined as that instant when an aircraft touches down and its tires are skidding along the runway).

2. TEST PROGRAM

Aircraft rollovers and arrestments with the F-100, F-101, F-106, and A4D aircraft were conducted. Rollovers were made at various points between the support blocks to determine the least probable engaging point.

Tests to determine the spin-up effects of heavy aircraft touching down on the retracted cable were conducted with the normal airport traffic (DC-8, Boeing 707, C-141, etc.). The BAK-14 at NAFEC was a particularly good target because the Instrument Landing System (ILS) glide slope terminated just short of the cable, which located the touch down point exactly on the arresting pendant.

All tests were conducted at the approach end of runway 13 (Figure 2). This location provided a 2,300 foot acceleration distance and 7,700 feet deceleration distance in the event of a missed engagement. As an additional safety factor, the far end arrester was available as an emergency arresting system.

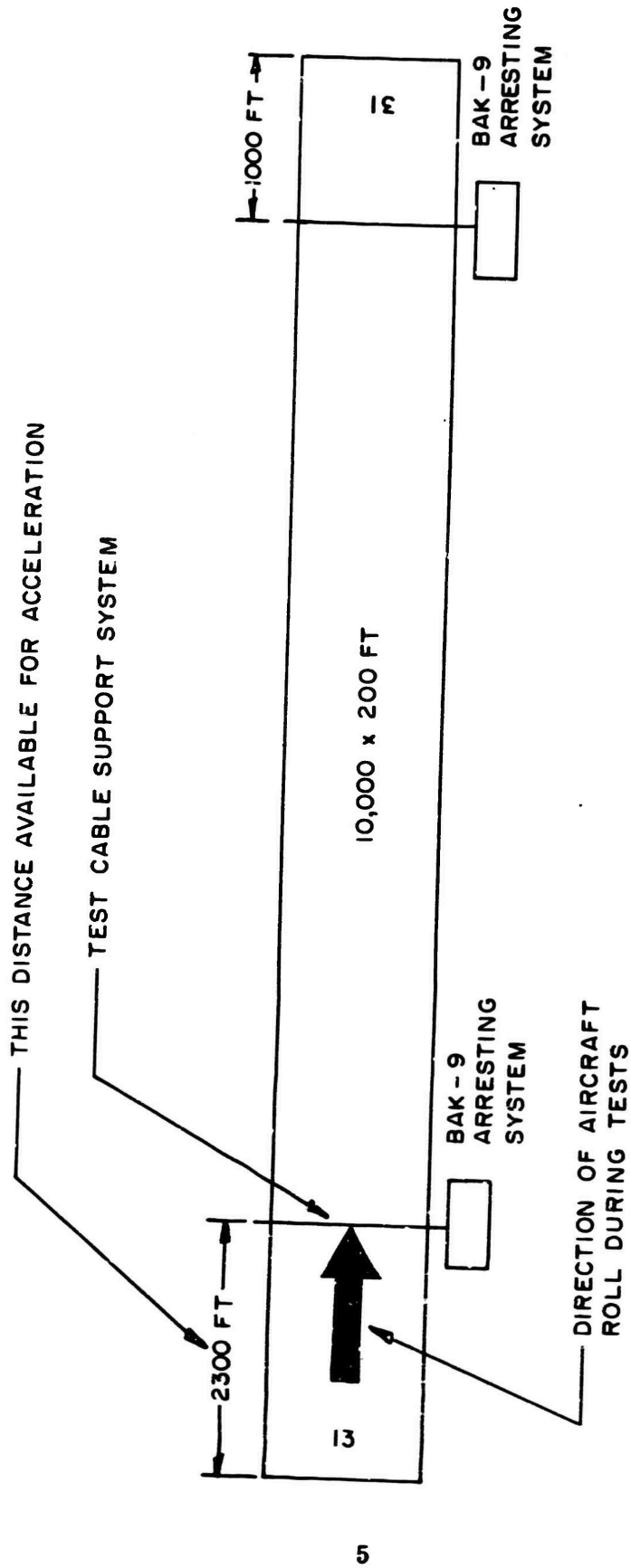

Figure 2. Test Runway at NAFEC

ASD-TR-69-9

To insure civil aircraft compatibility with the retracted system, the following aircraft were taxied over the system: Mooney Mark 21, Aero Commander, Piper Cherokee (PA-28), Piper Commanche (PA-24), Piper Super Cub (PA-18), Stinson 108, Lear Jet Model 241, and Cessna 172. The rollovers were conducted at the support block and midway between supports, the most critical positions.

3. INSTRUMENTATION AND PHOTOGRAPHIC COVERAGE

The nature of the test program dictated that no instrumentation was needed, but data in the form of photographic coverage was required. Engaging ground speeds were obtained from theodolite cameras. A 16 MM hand pan motion picture camera which operated at 24 frames per second and four remotely controlled high speed motion picture cameras which operated at 1,500 frames per second were used to document the program. The hand pan camera provided coverage of the engaging and arresting action. The remote cameras provided information on cable dynamics and engaging action.

SECTION III

DESCRIPTION AND OPERATION OF EQUIPMENT

The installation was comprised of 24 identical cable support boxes interconnected with an air line, an electrical conduit, and a drainage tube. Each support box had a separation distance of eight feet. Two configurations of the system were tested: (a) the cable was retracted onto the runway surface, and (b) the cable was retracted into a cross-runway slot which covered the center 100 feet of the 200 foot wide runway.

The basic system characteristics were: (a) for the cable supports to firmly grip and hold the arresting cable 2 1/2 inches above the runway when the supports were in their raised position, as shown in Figure 3, and for the supports to shed the cable in the event of an engagement; (b) when the system was retracted, as shown in Figures 4 and 5, cable shedding due to the wheels of heavy aircraft spinning up on the retracted cable would be prevented; (c) in the event of air or electrical power loss, the rubber torsional springs returned the supports to their raised position, ready for arrestment; (d) control was from the tower unless specifically relinquished by the tower to the runway edge control unit; (e) the neoprene cable support blocks would deflect harmlessly out of the way if impacted by aircraft tires.

A schematic diagram of a single support box can be seen in Figure 6. The block that held the cable (referred to as the cable support block in this report) was mounted on a lever arm (spring-arm assembly) which pivoted about a rubber torsion spring. In order to retract the supports when not in use, air was remotely applied at a pressure of 125 psi via a solenoid actuated valve to a commercially available automotive air piston chamber and linkage. The rubber torsion bar provided the force to raise the supports when the air pressure was released, either intentionally or because of a malfunction. This feature always assured that the raised or fail-safe position was available in the event of equipment failure. Limit switches, installed on the spring-arm assembly indicated the raised (up) or retracted (down) positions for each support. The system could be either radio or wire controlled to raised or retracted position from either the control

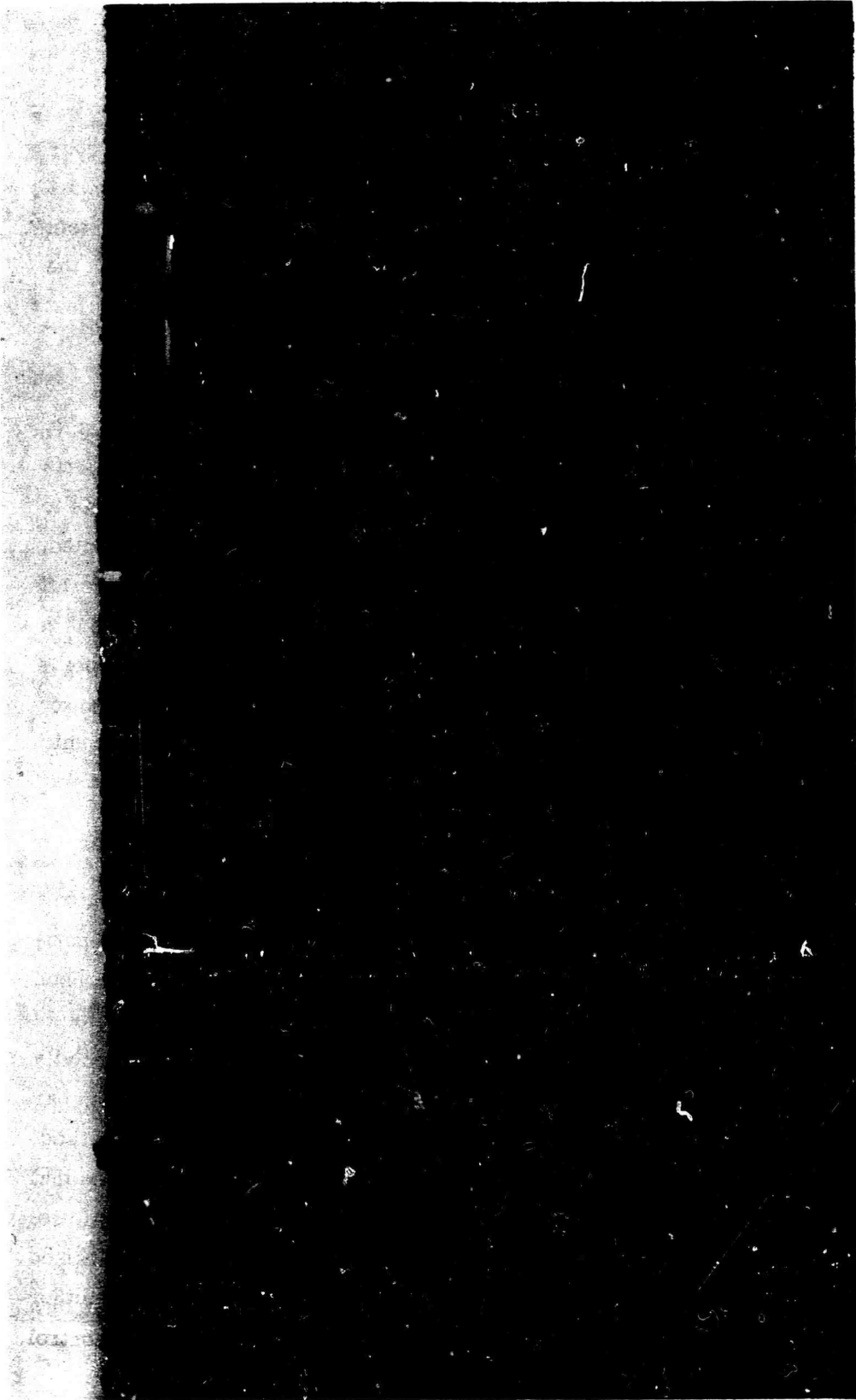

Figure 3. Arresting Cable in Raised Position with Slotted System

ASD-TR-69-9

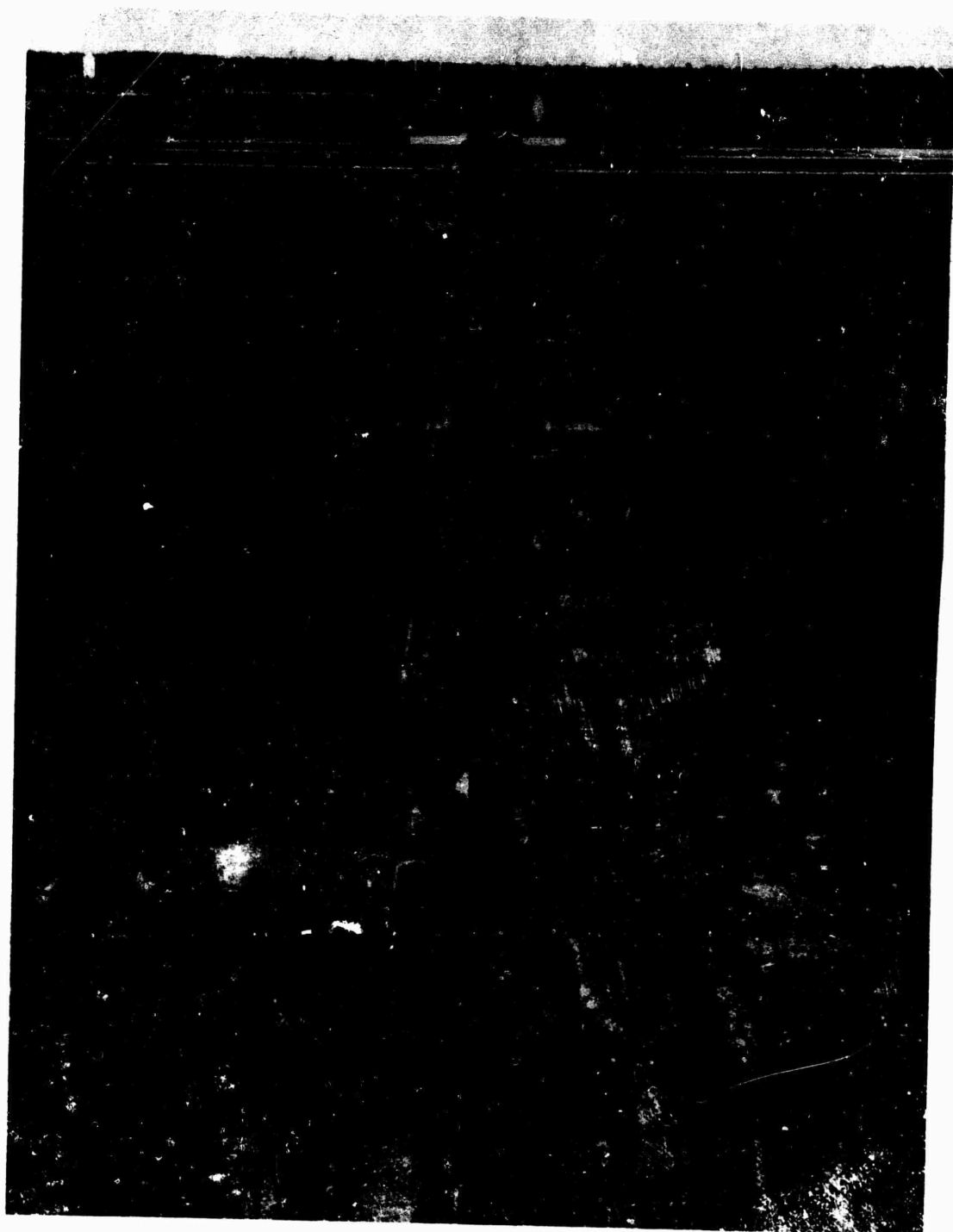

Figure 4. Arresting Cable Retracted into Cross-Runway Slot

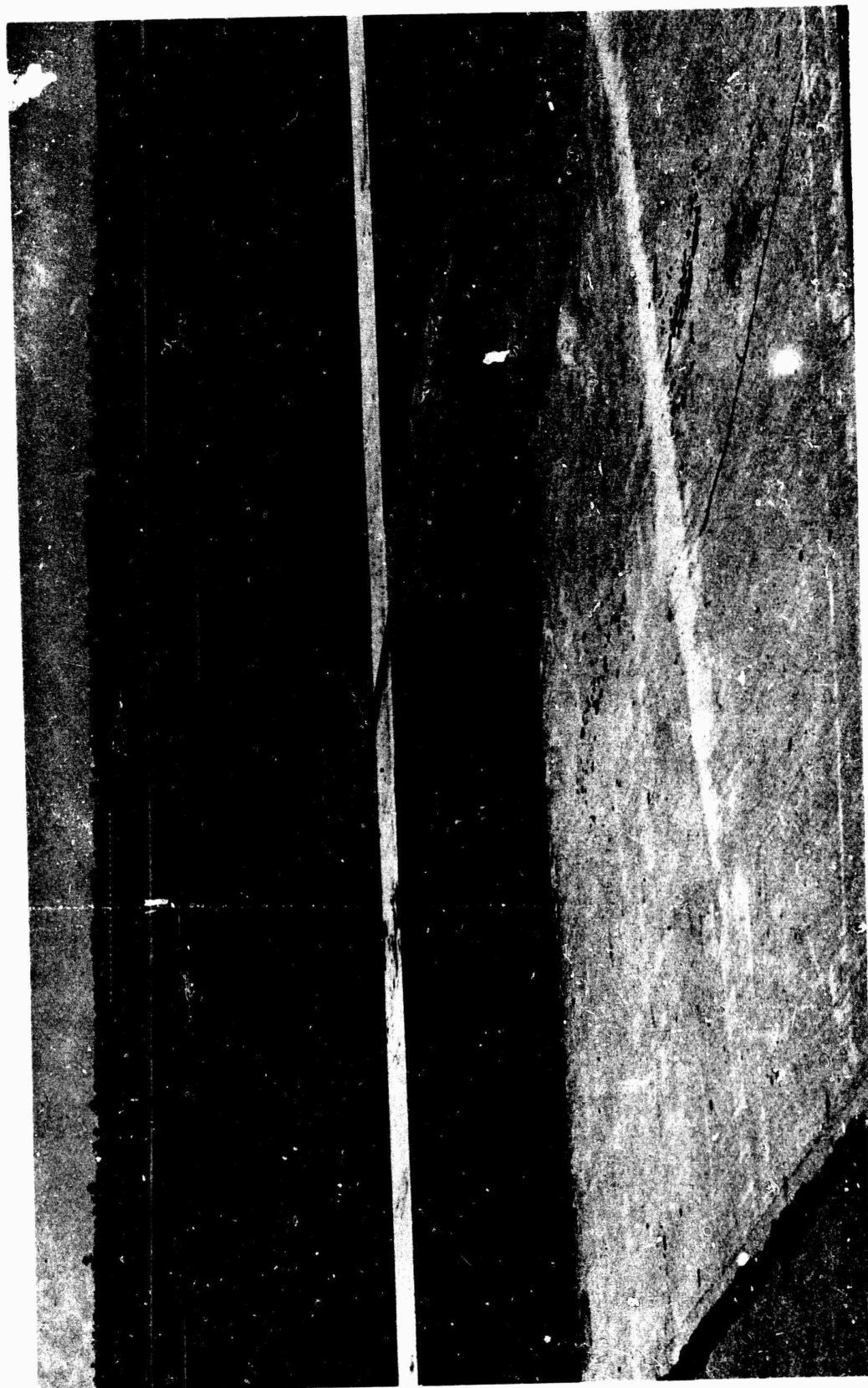

Figure 5. Arresting Cable Retracted onto Runway Surface

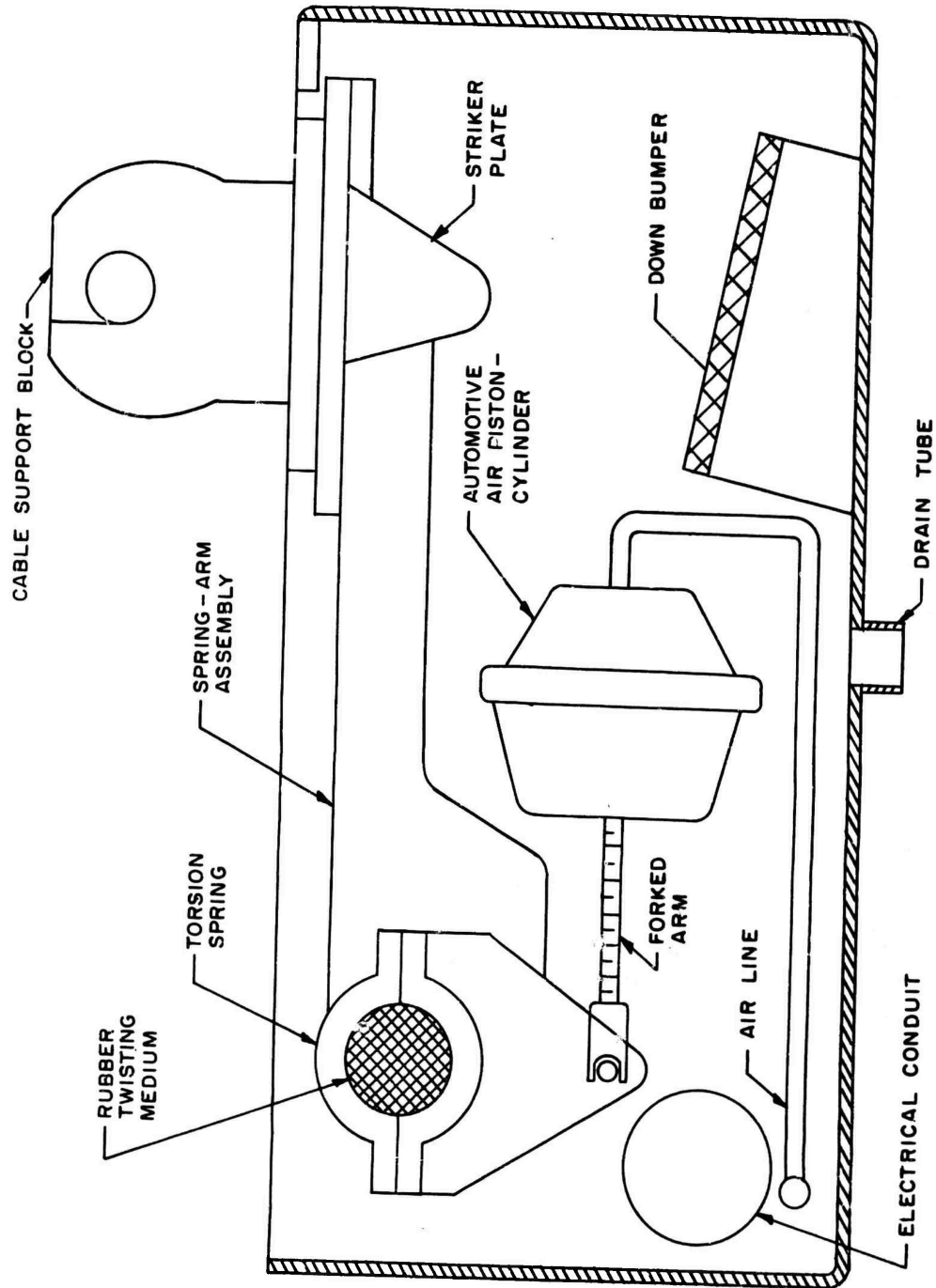

Figure 6. Schematic Sketch of Cable Support Box

ASD-TR-69-9

tower or the runway edge. A thermostatically or manually controlled heater circuit was designed to prevent ice formation in the support boxes. Drains were provided from the support boxes to the runway edge drainage system.

The system was designed to be fail-safe up to the time of part failure. Except for occasional inspection for parts replacement and possible cleaning, no significant maintenance effort should be anticipated. The cable support blocks may be damaged during an arrestment but not necessarily.

To provide energy for retracting the cable supports, three high pressure (3,600 psi) air tanks (1.5 cubic feet each) were placed in series in the BAK-9 pit. An air manifold was connected to the air source which consisted of a charging valve, tank pressure gage, pressure regulator, line pressure gage, and safety device.

When the three-way solenoid control valve was energized it connected the low pressure air line from the manifold to the air lines for the support boxes, thereby allowing air to pass from the high pressure air tanks to the automotive-air cylinders, which retracted the cable support blocks. As the air pressure in the line to the support boxes was raised, the spring moments were overbalanced and retraction occurred. When the solenoid control valve was de-energized, it closed the port to the low pressure air line, thereby maintaining pressure on the low pressure gage and it opened the operating cylinder air line to the atmosphere. This action decreased pressure and allowed the torsion spring to raise the supports.

Electrical signals were received from the control tower via the underground wiring or radio control unit. The tower could relinquish control to a runway edge control panel which was small and compact and had a 100 foot lead so that it could be carried outside of the pit. When the tower relinquished control, the runway edge operator had full control of the system. When the operator gave a command signal, a red light came on which indicated that the supports had responded to the command. Pneumatic operation of the supports occurred in about eight seconds. When the supports had responded, the light went off indicating that the command had been executed.

ASD-TR-69-9

A main junction box provided the terminals for all the electrical lines to the cable support boxes, the thermostat for controlling heater operation, a meter and probe for trouble shooting, and the necessary relays, circuit breakers, etc.

The BAK-14 electrical system required electrical power from the circuits that operated the arrestor rewind motor and consisted of heating elements, heater controls, a solenoid control valve, and indicator circuits. The 220 volt heater power was taken from the 440 volt circuit that powered the arresting gear rewind motor. It was interlocked with the rewind motor so that the heaters were turned off when the rewind motor was operated. Heater power was controlled by a relay actuated by a thermostat. The design arrangement was set up to allow the cable support boxes to be heated to approximately 15°F above the temperature of the surrounding runway pavement with a relatively small amount of electrical power and with very infrequent actuation of the thermostat. With the low electrical power used, the phase lag in the system was very long. The only time the heaters should be turned off, during cold weather, is when the arresting gear rewind motor must be operated. The source of power for the other circuits was a single 110 volt line. The indicator circuit was transformed to 35 volts.

In the raised position, the cable support blocks (Figures 7, 8, and 9) firmly retained the cable 2-1/2 inches above the runway surface and shedded it during an arrestment. Type A supports had a tough, solid neoprene rubber construction (50 durometer hardness). They were three inches wide and extended five inches above the runway surface in the raised position. They were attached to the spring-arm assembly with clamps and four bolts. Type B supports had a neoprene construction (50 durometer hardness) and a metal plate was imbedded in its base for extra strength. The major dimensions were the same as the Type A supports. The "nose" on the block was designed so that the support had better cable retention than the Type A supports during spin-up. The front hooked onto the runway edge (Figure 10). The Type C supports (60 durometer hardness) had the same internal construction as Type B, but they were designed to break-away under severe spin-ups, instead of retaining the cable when heavy spin-ups occurred (Figure 11). The breakaway donuts then supported the cable. This support was only two inches wide. All the blocks were readily replaceable when

ASD-TR-69-9

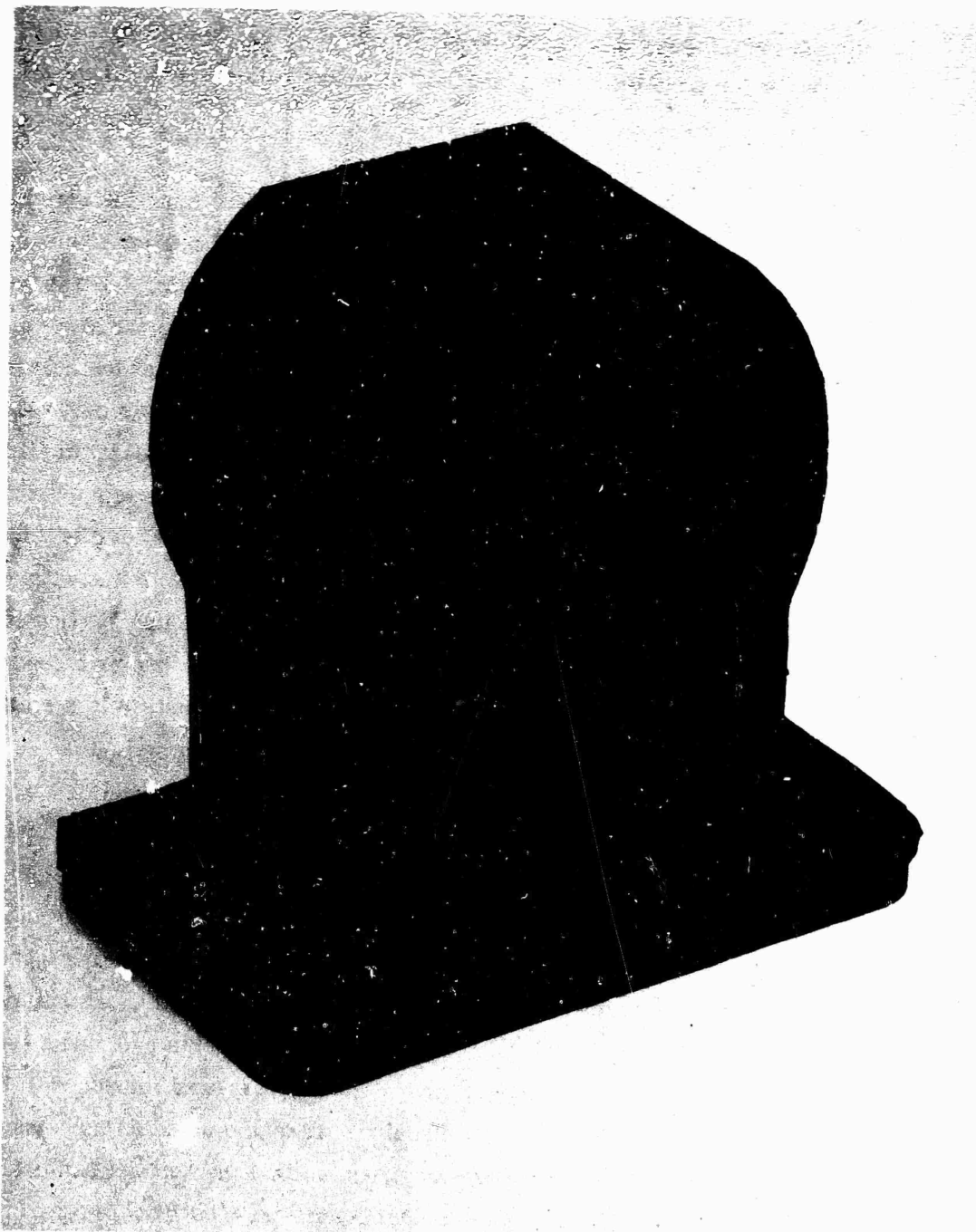

Figure 7. Type A Cable Support Block



Figure 8. Type B Cable Support Block

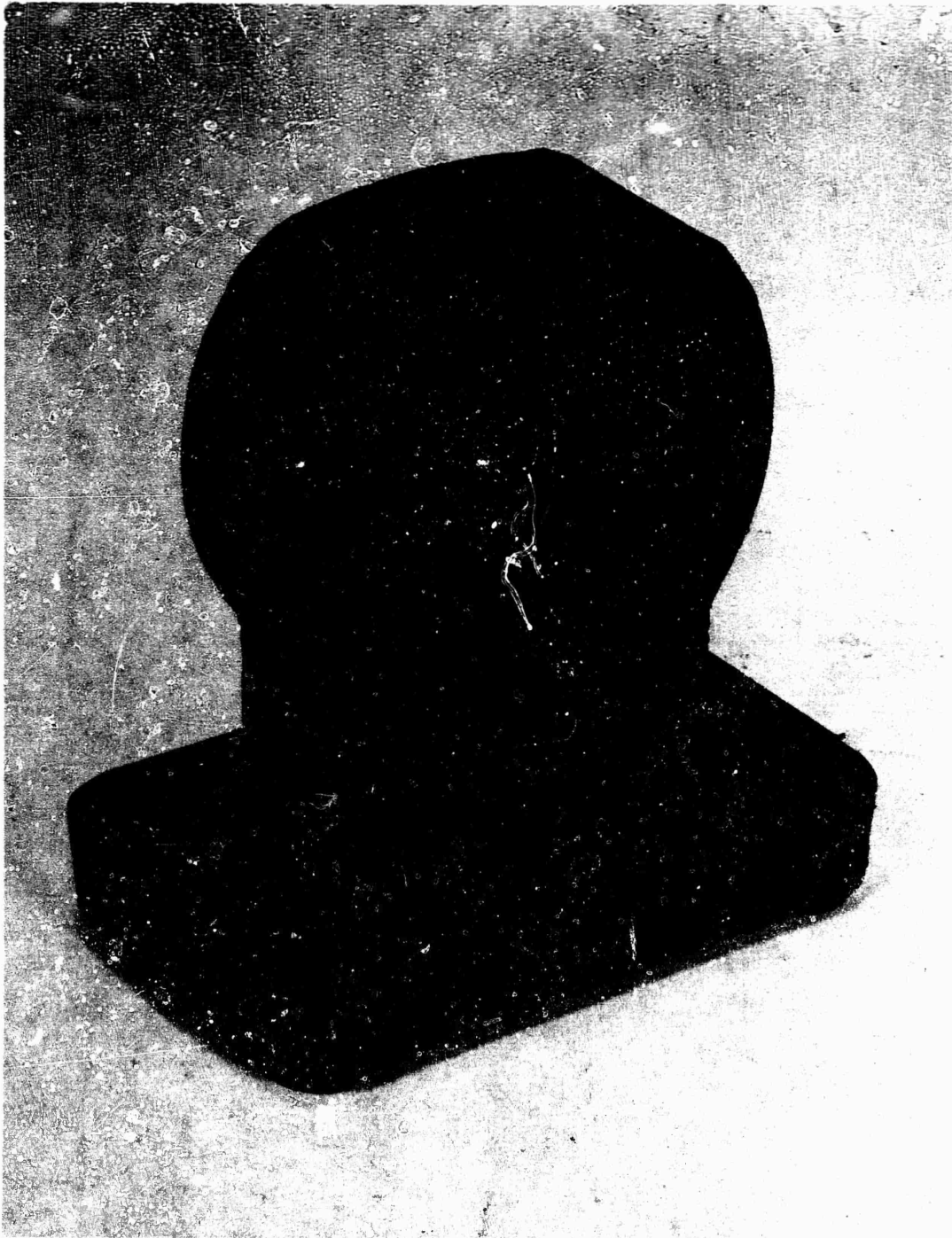

Figure 9. Type C Support Block

ASD-TR-69-9



Figure 10. Retracted Type B Cable Support Block



Figure 11. Type C Block After Heavy Aircraft Spin-Up

ASD-TR-69-9

they were in the raised position by removing the four bolts which attached them to their support arm. Block replacement required approximately one minute.

The cable was inserted into the Type A and B blocks by inserting a two foot length of 1-inch diameter tube or broom handle into the cable hole, then rotating the tube in the direction which brought the block slit parallel to the arresting cable. The cable was then placed over the opened slit and partially driven in with a shoe heel. The tube was then removed and the cable pushed all the way in. The technique required approximately five seconds.

The Type C supports were installed on the cable with a mandrel similar to that which is presently used to install the standard donuts.

The support blocks were mounted on the free end of the spring-arm assembly. This assembly was mounted on two brackets welded inside the cable support box and attached by four bolts to the brackets. The arm was keyed to the torsion spring so that the arm angles were fixed. Also mounted on the arm were a rubber gasket which acted as the up stop, a crank under the spring by means of which the air cylinder retracted the arm, and two mercury position indicating switches. The two mercury position indicating switches responded to switch angle. They were positioned on the arm so that the up switch closed 1° to 3° below arm level. The down switch closed 1° to 3° before the arm reached its down position (8° to 10° below level). All the up switches were connected in series as were the down switches. Thus the closing of a circuit indicated that all arms were either in their raised or retracted positions.

The torsion spring provided the force to raise the supports when air pressure was released from the circuit. In the normal, raised position, the torsion spring was unstressed, but when the cable was retracted, the hard rubber core of the spring was twisted and stressed but could not raise the spring-arm assembly until the air pressure was released from the air cylinder or a part failure occurred.

The air chamber was a standard automotive air brake operating chamber except that its clevis end was replaced by a special fork fitting. It was permanently mounted in the support box and connected to the air line. When the air line was pressurized, the chamber diaphragm pushed the fork end against the crank on the spring-arm assembly to deflect the spring to its retracted position. When the air line was not pressurized, a tire impact on the block would deflect the spring arm downward, but the air chamber diaphragm would not move.

A 1/2-inch thick rubber pad was provided as a down bumper to cushion the violent downward velocity of the spring arm assembly that was generated by tire impacts. It was designed so that it could be replaced by a thicker pad if it was found necessary to increase the size of these bumpers.

Located on the bottom of the support box under the air chamber air inlet connection was a 1-inch diameter drain hole covered with a steel screen. The screen was provided to prevent the possible entrance of mice into the support box and to prevent small tools from falling into the drain pipe. If the drain pipes are kept clear, water should properly drain off. If the drain lines are blocked, and water does collect, at a depth of 1-inch it will flow out through the three inch diameter conduit into the pit. This is a catastrophic situation and should not be permitted to happen.

The cross-runway slot width was 1 1/2 inches for the one inch arresting pendant. The 1/2-inch excess width was provided to permit a kinked cable to be retracted. Only the center 100 feet of the 200 foot wide runway was slotted because heavy aircraft generally touch down in this vicinity.

SECTION IV

TEST RESULTS

1. ENGAGEMENT AND SPIN-UP TESTS

A total of nine rollovers and twenty successful engagements were accomplished against the BAK-14, F-100, F-101, F-106, and A-4D aircraft were employed for these tests. Appendix I gives complete tabulated results.

Because of cost considerations and high volume of air traffic, it was decided to install the system on an active runway at NAFEC. This limitation and safety considerations severely restricted the number of engagements and engaging speeds. Consequently, extrapolation of test data was necessary to determine engaging probabilities at higher speeds and for different aircraft. However, the high traffic volume provided an excellent in-service test which could not have been achieved at a normal test site. Because of safety considerations, all tests except one had to be conducted in the direction to simulate an approach end engagement. Since the system has bidirectional capabilities, the engaging reliability should not vary with the direction of engagement.

The test program was conducted in three phases because of problems which arose during the program. The first modification was made to increase the cable retention characteristics of the support blocks during spin-up. The second modification resulted in a cross-runway groove being installed into which the cable could be retracted.

The Phase I tests, which began on 30 September 1966, involved the basic system which was designed to retract the cable onto the runway surface with the Type A cable support blocks (Figures 6 and 7). The aircraft tests began with four rollover tests utilizing the F-100 at speeds from 80 to 120 knots ground speed. These tests were performed to determine the location of the critical engaging point (with respect to cable height above the runway) along the cable and to study cable dynamics prior to an actual engagement. Five successful hook engagements were then conducted at speeds ranging from 65

ASD-TR-69-9

to 120 knots at various positions along the cable from midway between the supports to the arresting hook contacting a support block. This event was preplanned to determine if the support block would cause a missed engagement. No adverse effects were experienced and the hook slid off the block and engaged the cable.

In general, the tests showed that the two support blocks, adjacent to the hook engaging point and the supports at each end of the system were destroyed during each arrestment. An average of four Type A blocks were damaged per arrestment, regardless of speed.

After completion of these arrestments, a commercial 707 was observed touching down on the retracted cable. As the wheels skidded across the cable, it was pulled from 14 supports (all had been retracted). This showed the cable gripping strength to be inadequate for wheel spin-ups of large aircraft.

In order to obtain some factual data on spin-ups, a USAF C-135 was acquired to attempt spin-ups on the retracted cable, while high speed photography was obtained. The feat was accomplished and the cable was pulled from 17 support blocks. Photo coverage revealed that the tremendous impact forces of the heavy aircraft wheel spinning-up on the cable rolled it four feet forward of the supports down the runway.

The problem was that if the landing runway was changed and the supports were raised from the tower, the cable would not be supported even though the support blocks were raised and the tower received the raised indication.

As a result of this failure, it was decided to test the system with different support blocks which would have increased cable gripping characteristics (Appendix II). Type B (Figure 8) and Type C (Figure 9) supports were thus developed and tested in Phase II. It should be noted that during the six month interval between the Phase I and Phase II tests the system was returned to the standard donut supports. During this time period a groove had been worn across the middle half of the runway with a mean depth of $3/4$ inch and a maximum depth of $1\ 1/4$ inches.

ASD-TR-69-9

The Phase II tests began on 23 March 1967. Rollovers were not made because of the necessity to use the runway for hook engagements whenever it could be obtained for test purposes. It was decided that the cable dynamics with the Type B and Type C support blocks would be similar to those for the Type A blocks. The primary reasons for this conclusion were because the Type B and C block masses were similar to the Type A supports, for which cable dynamics data had already been obtained and because all support blocks had fixed anchorage points.

Six attempts were made with the F-100 to engage the Type B supports at speeds from 70 to 109 knots. The hook engaging positions varied from mid-cable to almost contacting the block. One attempt was unsuccessful because the hook contacted a flush mounted centerline light and bounced over the cable.

Two successful arrestments were made with the F-100 engaging the cable supported by Type C blocks. The speeds were 71 and 108 knots. The 71 knot arrestment was made midway between the blocks and using the breakaway portion of the Type C blocks as the sole cable support (see Figure 11). The 108 knot arrestment was made with the Type C blocks, alternated with the Type B blocks.

Three successful arrestments were then made with the F-106 and the Type B blocks at speeds ranging from 80 to 120 knots. The hook positions varied along the cable.

Three attempts were made with the Type C blocks at speeds ranging from 65 to 127 knots. One successful engagement was performed with the complete block, midway between the supports. The break-away donuts supported the cable during the other two test events. A failure occurred midway between these supports at a speed of 127 knots. Data analysis revealed that both hook and cable bounce were responsible for the failure.

Spin-up tests were then conducted to observe what the effects would be on these blocks. A C-135 was used to perform the spin-ups, but the pilot was unable to touch down on the cable hard enough to satisfy the project engineer.

ASD-TR-69-9

It was then decided to let air traffic serve the purpose of the test vehicles and the barrier crew would daily monitor the results and record whether or not the cable remained in the support blocks.

It was observed that the Type B blocks were almost able to retain the cable. The only blocks which were pulled out were the ones around the point where the left and right main gear actually touched down. However, this performance was still not adequate to qualify the supports as acceptable.

The Type C blocks almost performed as designed. Whenever a large aircraft would touch down on the retracted cable, the donuts would breakaway and remain with the cable. However, it was decided that these blocks were not completely adequate because the supports were designed to break away occasionally and not during every landing, as was the case during the tests. Another feature which was unsatisfactory was that the cable hole had to be oversized in order to insert the blocks on the cable. Whenever the breakaway donuts were supporting the cable they would tend to work themselves to the runway edge as the air traffic rolled over the cable. In due time this condition left the cable prone on the runway at the center when the cable should be raised.

The new supports Type B and C proved to have better cable retention characteristics during spin-ups than the Type A supports, but they were still not able to satisfactorily retain the cable during spin-up.

It was then decided that the only way to absolutely alleviate the cable shedding was to locate the cable beneath the runway surface in a slot. Based on past test data with other systems, the slot approach had not previously been considered favorably because it was believed cable dynamics would probably cause the cable to be in the slot when the hook passed the cable. Since other means had been unsuccessful, it was concluded this approach must be tried to prove or disprove this opinion.

The system was redesigned to enable the center 100 feet of the cable to be retracted under the runway surface into a slot. Phase III tests began on 30 Sep 1968.

ASD-TR-69-9

An F-101 was acquired to perform rollover tests of the new design so that high speed motion picture coverage could be obtained and studied to determine whether or not the cable would be forced into the slot by the landing gear as it rolled over the raised cable. Due to the extensive maintenance inspection, which must be performed after each F-101 engagement (400 manhours), tests were limited to rollover tests with high speed photographic coverage.

Four F-101 rollover tests were conducted at speeds from 80 to 120 knots in a direction simulating an approach end engagement. One rollover was conducted in the opposite direction at an estimated 35 knots. Data analysis revealed that any aircraft could reliably engage the system from either direction regardless of speed. The engaging reliability was validated with three successful engagements by a Navy A-4D at speeds up to 120 knots ground speed.

At no time during the rollover tests or engagement tests did the cable appear to enter the slot. Masking tape was used to partially cover the slot so that an indication of whether or not the cable entered the slot would be visible.

The system was then tested to see what effects aircraft spinning up on the cable would have. The BAK-14 was left retracted for two weeks with no cable shedding or system damage occurring.

2. RECYCLING TESTS

The rewind times varied for the different cable supports. With the Type A and Type B supports, rewind time was primarily a function of how fast the cable could be retrieved. Two men installed the cable in all of the supports within two minutes after the cable has been rewound. When blocks were damaged during arrestments, they were replaced while the cable was being retrieved. It took approximately one minute for one man to replace a support block.

The Type C blocks were definitely not conducive to fast rewind times because the cable had to be disconnected for installation. Type C blocks were placed at the edge of the cable as spares during the test and were used to replace the blocks which were damaged during the arrestment. This technique was similar

ASD-TR-69-9

to the procedures which are being used with the standard donuts, but cannot be recommended because the rubber enclosed steel base plate tended to become damaged during rewind. However, the blocks were still able to be used to support the cable. If it was required to make two arrestments, one after the other, the breakaway donuts could be used as the sole cable supports and the time between arrestments would be strictly a function of how fast the cable could be rewound. An electric saw had to be employed to remove the breakaway donuts from the cable.

The exhibit specified that the BAK-14 recycle (raise or retract) time should not exceed fifteen seconds. In actual performance the system repeatedly raised and retracted in eight seconds.

3. DRAINAGE TESTS

A test plan had been prepared to test the BAK-14's drainage system. However, an unusually heavy rainstorm dropped six inches of rain in a two and one-half hour period. The runway edge drain at the pit could not carry off the water as fast as it fell, resulting in flooding of the two support boxes at the end of the system nearest the pit. The results were that water flowed into the pit via the electrical conduit and main junction box. All switches in the box were damaged by the water and had to be replaced. To remedy this situation the conduits were plugged with oakum and the conduit was cut back from the junction box so that the flow would be down the pit wall behind the junction boxes. Common rainstorms have not caused any problems since the system was repaired.

4. THERMOSTATIC HEATER TESTS

At the end of the Phase I tests the heaters were turned on for testing and a distinct temperature difference was felt between the concrete surrounding the support boxes and concrete further out on the runway. The heaters were left on for a complete winter test.

It was periodically discovered that the heaters were not working. However, when they were turned on they worked perfectly. An analysis of the system at

ASD-TR-69-9

the beginning of the Phase II tests revealed that the push button controls on the interlock with the BAK-9 rewind motor did not close the heater power circuit after rewind. During routine inspections of the BAK-9 the rewind motor was operated but the heater power was cut off and did not automatically turn back on as designed. Since these push button switches were redundant in the circuit, they were removed. The interlock was then fully automatic and was checked several times during rewind after arrestments.

The other heater problem which occurred was due to heavyweight rollovers. Several times when the system was raised, heavy aircraft rolled over the system and severe impacts, caused by the spring-arm assembly contacting the bottom of the support boxes, jarred the support boxes loose from their concrete foundations. The box in turn rubbed the leads to the imbedded heater, thus causing a short and burning out the resistors. The boxes involved were numbered eleven and fourteen, with the box nearest the BAK-9 pit numbered as one and the farthest box numbered as twenty-four.

5. CONTROL TOWER EQUIPMENT TESTS

The radio control system was demonstrated with the tower equipment located outside of a building and the pit equipment located inside. The operation was demonstrated by lighting lights using the same signal as required to operate the controls in the pit. The test was completely successful and the equipment was delivered.

Prior to the Phase I tests the system was put on tower control to test the operation of the wire control installation. The test was completely successful.

6. CIVIL AIRCRAFT TESTS

All the civil aircraft, mentioned in Section II, were tested by the FAA after the Phase II tests were completed. The cable was retracted onto the runway pavement and the aircraft were taxied, at high and low speeds, over the cable. The Lear Jet was incompatible with this system because the nose wheel shield was located one-half inch above the runway and this shield contacted the cable. With the BAK-14 cable retracted into a cross-runway slot, the Lear Jet had no problems with rollover. All the other aircraft were compatible with all versions of the BAK-14.

ASD-TR-69-9

The FAA has prepared a detailed report entitled, "Retractable Pendant Cable Support System for BAK-9 Arresting Gear" which covers these tests.

SECTION V

FUNCTIONAL ANALYSIS

1. CABLE SUPPORT BLOCKS

Retention of the retracted cable during spin-up was the single major problem with the BAK-14. Photo coverage of the situation revealed that, the aircraft tires skidded 300 to 400 feet immediately after touchdown. These skidding tires imparted tremendous forces to the retracted cable causing it to roll at least four feet forward. Since the support block was made of frangible material, the leading edge was unable to retain the rolling cable.

To solve the spin-up problem, various block designs (Figure 12) were studied, but all configurations were inadequate. Type A supports were primarily designed to support an arresting cable for hook engagements, with minor concern being given to spin-ups. The Type A blocks were excellent cable supports, but during spin-ups their leading edge was too weak to resist the heavy impact loads and the cable was easily able to roll out of the supports. The Type B supports were designed so that the block's leading edge would be restrained from moving by hooking onto the edge of the support box (Figure 10). Based on static pull tests, these supports had a 50 percent greater cable retention capability than Type A (Appendix II). Under actual test conditions, the Type B blocks performed very well under spin-up, with only the supports on each side of the tires shedding the cable. Type C supports were designed to prevent cable shedding under most conditions; however, if cable shedding should occur, a part of the support would breakaway with the cable and support it until maintenance personnel could install new supports. In tests, these supports were unable to satisfactorily retain the cable, but in every case the breakaway portion separated from the block and supported the cable.

In one spin-up test with the retracted system the Type B and Type C supports were installed alternately. The Type C supports tore away as designed, and the Type B supports retained the cable.

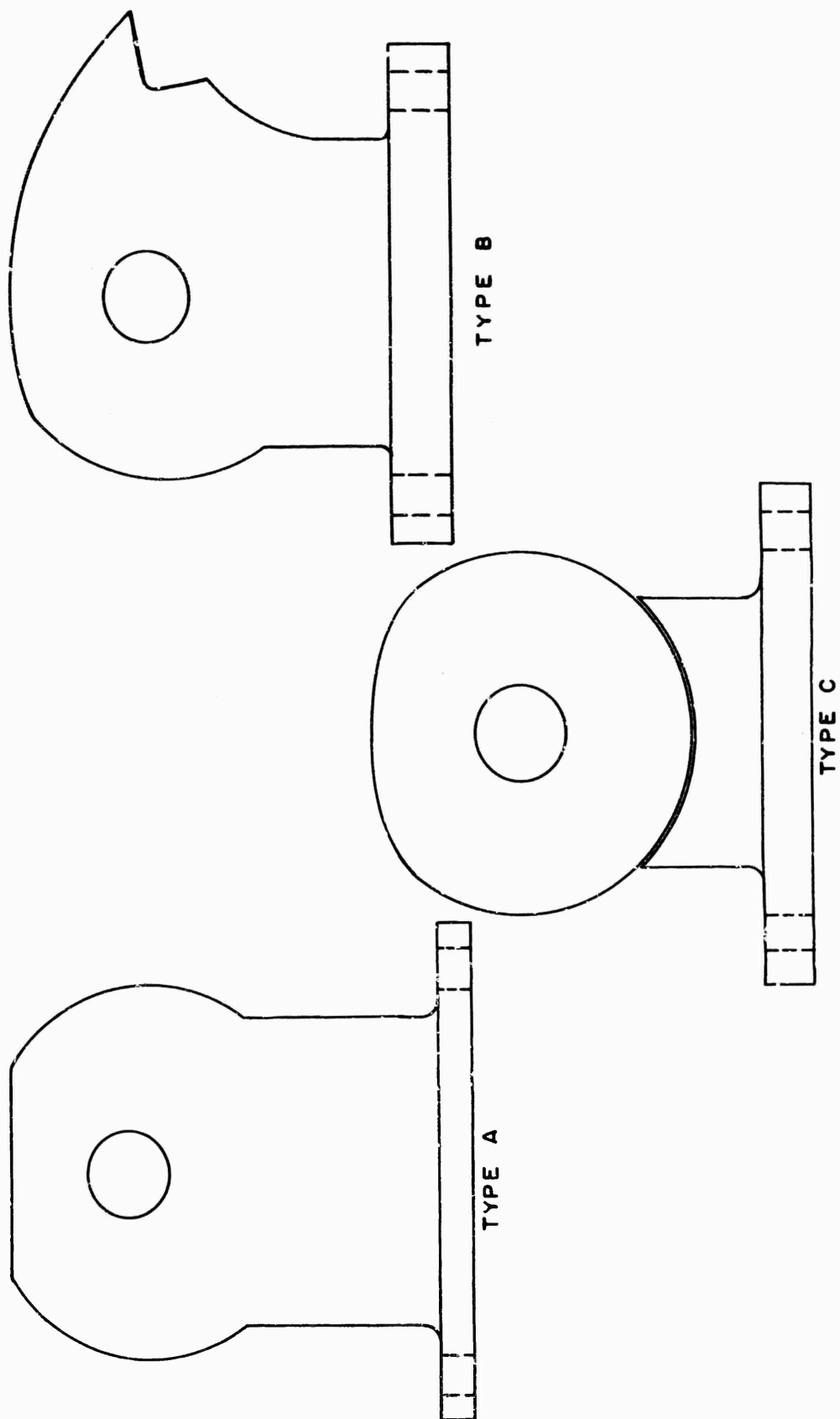

Figure 12. Sketches of Support Blocks

With the three failures, the contractor performed research studies on a 60 durometer hardness polyurethane block similar to Type C. This block was static tested at the contractor's facility (Appendix III). The block was stretched to the limits of the test machine without any detrimental effects. In comparison with neoprene this material showed:

- a. The modulus of elasticity of the polyurethane was slightly lower than that of the neoprene, resulting in a somewhat more flexible block.
- b. The toughness of the polyurethane was far greater than that of neoprene, reflected by the deflection curve (Figure 31).
- c. The polyurethane block had greatly improved cable gripping characteristics and might be satisfactory for service use.

The explanation of cable shedding was that the supports were only able to partially absorb the energy transferred to the cable from the landing aircraft. Since the state-of-the-art in cable support design had been reached with Types B and C, the only solution available was to design the BAK-14 so that no energy from the landing aircraft could be transferred to the cable. The solution was to retract the cable into a cross-runway slot. This approach was not originally taken because past experience with slots showed that cable dynamics frequently caused the pendant to be in the slot when the hook reached the cable.

It was believed that a cross-runway groove would work with this system because it was unique to any other grooved system. This uniqueness evolved because the support was located on a lever arm which pivoted about a fixed point and the centerline of the retracted cable was off-center from the centerline of the raised cable (Figure 13). The theory was that when the aircraft wheels rolled over the raised cable, the cable was thrown forward and then cable dynamics caused the cable to vibrate vertically along its extended centerline. Thus, if the slot's centerline was not in line with the cable centerline then the cable would not enter the groove.

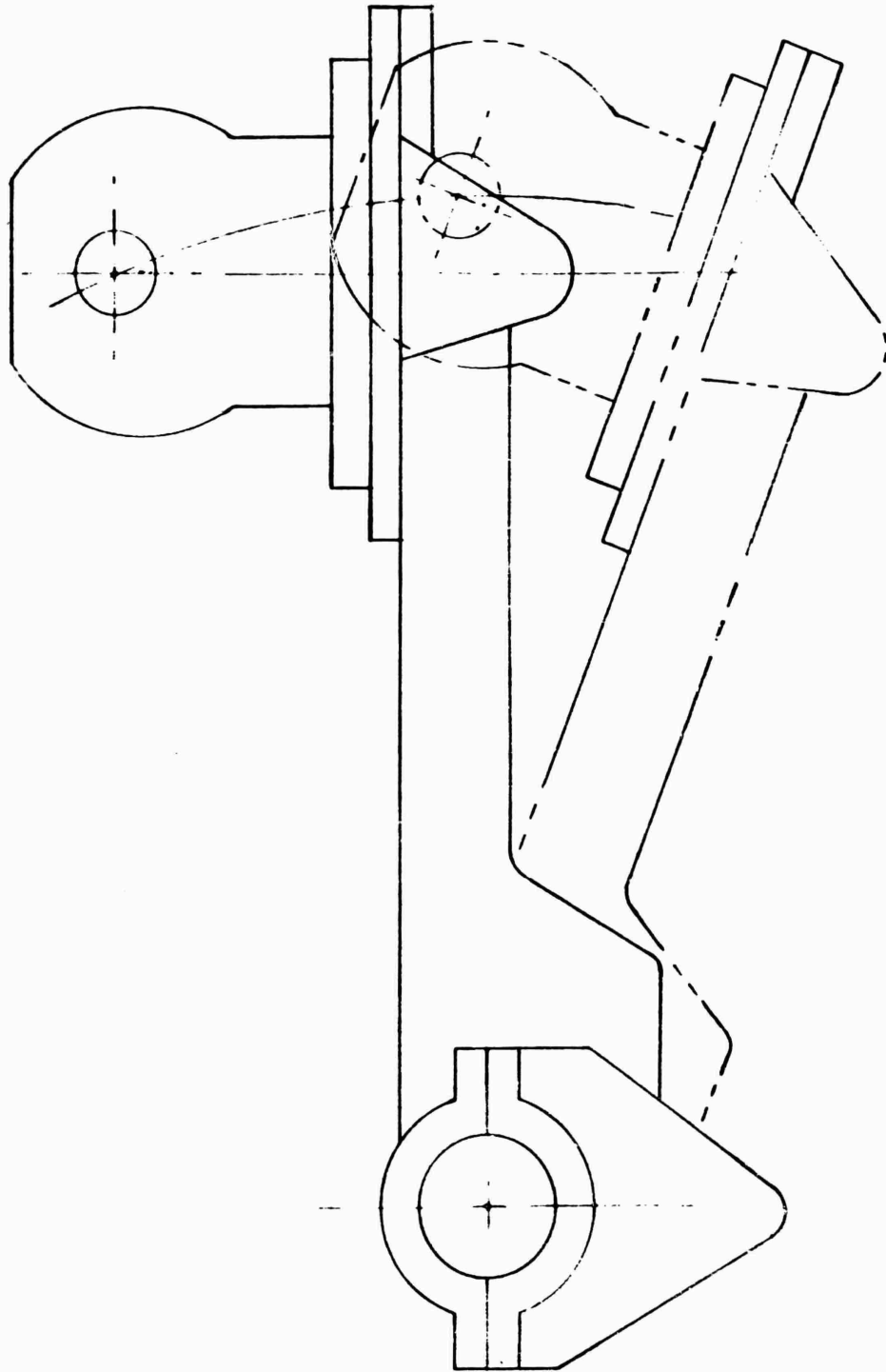

Figure 13. Off-Center Characteristics of BAK-14

From the testing with the cross-runway slot it was positively learned that when the aircraft rolled over the cable, the cable was thrown forward by as much as eight inches at high speeds. Figure 14 shows how the cable throwing action was determined. Masking tape covered the slot to determine if the cable entered the slot and how far the cable was thrown forward. Figure 14 shows the results of the F-101 rollover which simulated a far end rollover. It can be seen that the cable was thrown forward by two inches at a ground speed of approximately 35 knots. Cable vertical motion was proven by the fact that the masking tape across the slot was not broken after any rollover.

It was finally decided that retracting the cable into a cross-runway slot was the solution to the spin-up problem. Type A support blocks were acceptable for use with this design. Since the system has been retracted, no support problems or cable shedding have been experienced.

Another problem which was encountered by the supports was that several Type A supports, on each side of the hook, were destroyed during each arrestment. A temporary fix of serrating the clamping plates was attempted but was not adequate to keep the supports from failing.

Analysis of this problem revealed that the block anchorage to the spring lever arm was sub-marginal. The engaging characteristics of the supports can be depicted diagrammatically as a wine glass cross section attached at the extremities of its base (Figure 15). The action of the support during cable extraction was (Figure 16): the wine glass opened to release the cable and the support was bent and pulled severely on the aft anchorage. Blocks adjacent to the engaging point tore out at their aft anchor bolts, necessitating the replacement of two blocks after an arrestment.

The initial fix of serrating the metal clamping plates to improve their gripping power failed. Testing with these plates showed no difference in characteristics. These initial tests showed that the gripping strength of the support block was equal to the attachment strength of the block.

The situation was remedied by imbedding a metal plate (Figure 17) into the bases of Type B and C blocks. This fix strengthened the base considerably

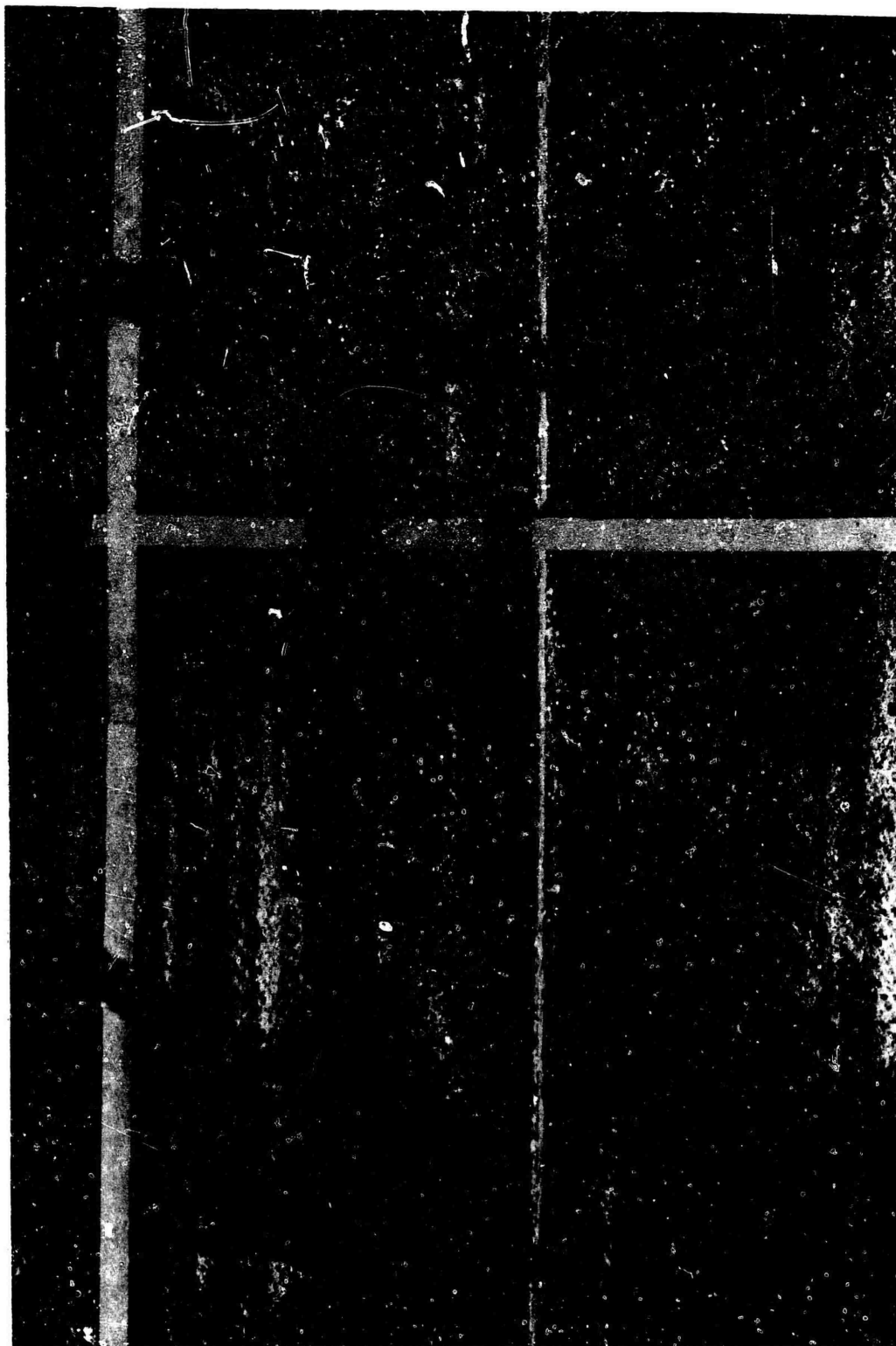

Figure 14. Determination of Cable Throwing Action

ASD-TR-69-9

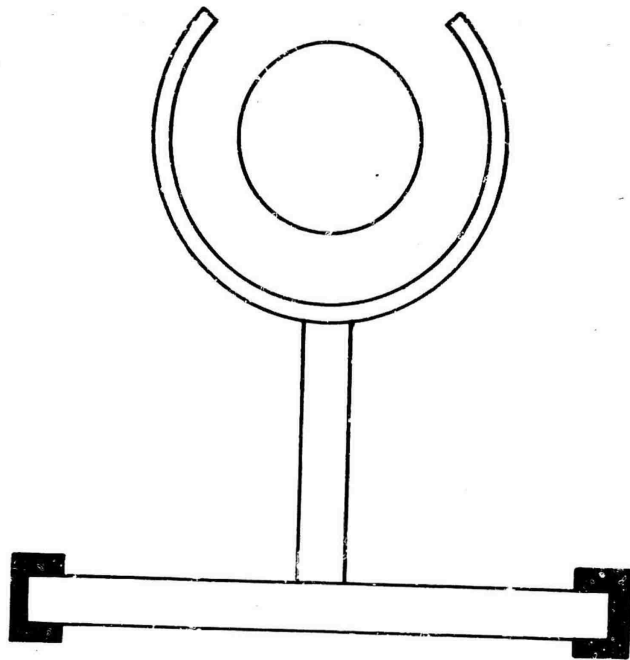

Figure 15. Schematic Sketch of Cable Support Block

ASD-TR-69-9

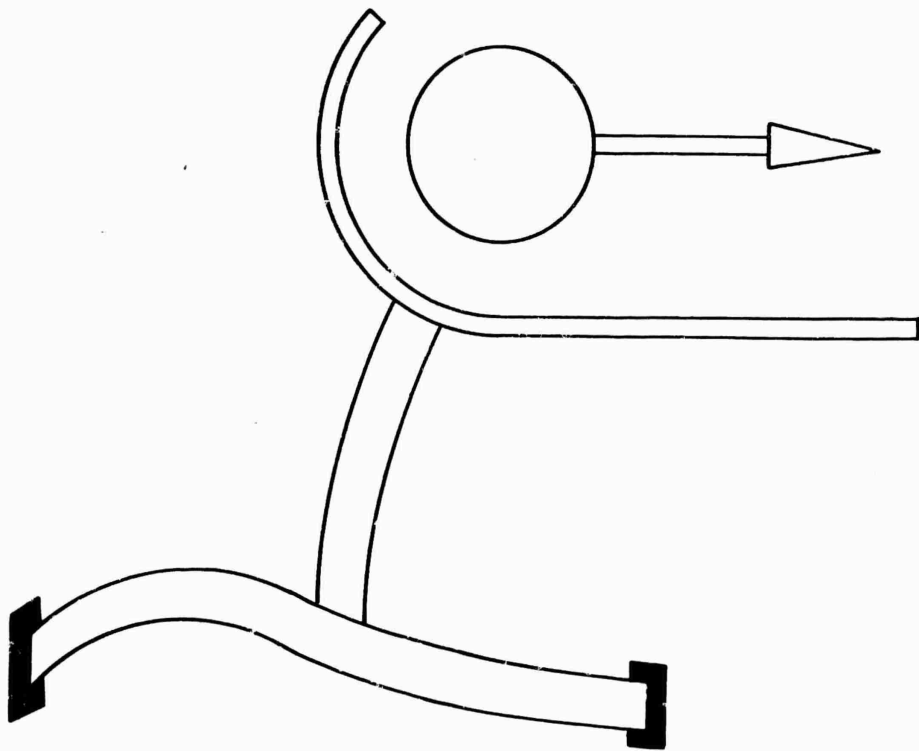

Figure 16. Schematic Sketch of Cable Being Pulled from Block



Figure 17. Type B with Separated Base Plate

ASD-TR-69-9

so that the Type B blocks failed only because of fatigue in the block itself (Figures 18 and 19). At higher engaging speeds, the blocks failed by tearing apart at the fatigue cracks. The Type B supports which were newly installed for the high speed arrestments were not destroyed during the highest speed arrestments. It is believed that a softer rubber would better stand repeated arrests and not fail in fatigue until after many arrestments.

Two blocks, at each end of the system (Boxes number 1 and 24), were destroyed in each arrestment. During the arresting process, the tape connectors initially move laterally across the runway until the kink wave reached the connector. These connectors destroy the blocks with a lateral impact.

Cable dynamics of the BAK-14 were superior to the standard donuts or polyurethane rail supports. During a rollover, the nose wheel drove the pendant down to the runway surface, thus partially dampening the kink wave. The force exerted by the system lifted the pendant to heights in excess of five inches; the cable then returned to its normal position because the anchored, massive support blocks damped out all vibrational tendencies immediately instead of vibrating unpredictably as do the standard donuts.

Occasionally the rollovers were so severe that the support block opened up and the cable left the support, but quickly returned before it had closed. This phenomenon only occurred with the Type A supports.

Whenever an aircraft directly rolled over a support block much more wear was experienced than when the aircraft tires didn't impact the support (indirect rollover). In an indirect rollover, high-speed motion-picture coverage revealed that the kink wave, produced by the aircraft wheels passing over the tensioned cable, pressed the support directly downward into the support box, which did not result in the impact and distortion that occurs with a direct rollover. A direct rollover, however, caused considerable distortion of the support block in the direction of wheel travel as the aircraft wheels passed over it, resulting in a materially lessened block and support box component life.

ASD-TR-69-9



Figure 18. Type B Support with Fatigue Crack



Figure 19. Type B Support Damaged by F-106 After 120 Knot Engagement

Quality of the molded block was found to significantly influence service life. In many blocks, which failed with only one arrestment, examination revealed that the blocks contained numerous air holes along the plane of failure. Generally, the blocks which were found to contain a greater number of voids usually displayed a shorter service life. Some of these defective blocks even failed when the cable was inserted.

2. ELECTRICAL SYSTEM

The electrical system consisted of a heater circuit for heater power and heater controls and an indicator circuit to indicate the positions of the support blocks. The heater circuit was arranged in parallel so that if a failure of any part occurred, the rest of the system would still operate. The indicator circuit, however, was arranged in series so that all supports had to correctly respond to the command for an indication to be observed.

During Phase II tests, the system failed to remain retracted because of repeated failures of fuses in the main junction box. The entire electrical system was checked for electrical troubles. Several short circuits were found and eliminated. However, the fuses continued to fail. The trouble was finally determined to be in the indicator circuit. It was found that a short was developing in a support box at the center of the runway. When the system was retracted, aircraft rollovers occurred as a result of normal runway operations, and occasionally one of the support boxes was contacted and the slight jarring which resulted caused an intermittent short in the indicator circuit. This short caused a current "spike" which blew out a fuse and the system raised (failed-safe). In order to withstand the peaked current, the circuitry was revised to add two load fuses in addition to the line fuse initially used, one for the indicator circuits and one for the heater control plus solenoid valve. With the new circuitry, the loss of the indicator circuit fuse did not affect raising or retracting the system. The load fuse on the heater circuit would insure that no future problems would occur with this circuit.

All future possible sources of short circuits were eliminated by removing the indicator switches from the center twelve support boxes. To obtain the proper indications, the outer box switches were left intact. These switches were used to indicate the positions of all supports.

3. POSITION INDICATING SWITCHES

As initially laid out the position indicating switches were designed to close 2° before the arms reached their raised or retracted positions. It was found that switch operation was erratic at this setting. A "level" sensing mercury switch was used in which a glob of mercury flowed to either end of a glass tube and made contact with a pair of electrodes at one end only.

Study of the erratic switch operation showed the position of the mercury glob was more a function of speed of switch rotation and vibration than switch position. The normal retraction and extension of the support arms was a slow, smooth motion leading to sometimes delay the angle at which the switch closed. Such a situation was undesirable in this system, but long life and mechanical simplicity of the mercury switches made their use desirable.

Corrective action was taken to increase settings from 2° to 4° before full arm motion.

Later on, after the installation was completed, erratic response was again found. Study of this trouble indicated that the individual support boxes were not precisely level. They had been installed flush with the adjacent runway surface, regardless of surface irregularity. Measurement of box angles showed boxes up to 1 1/2° off level, in any direction. Corrective action was taken to increase the switch angles by 1 1/2° on those supports showing erratic command completed response.

With the switches properly installed as just described, response became 100 percent effective.

4. DOWN BUMPERS

The down bumpers were a 1/2-inch thick 40 durometer neoprene rubber pad (Figure 6) which was designed to absorb the energy of an aircraft rolling over the raised or retracted cable. Due to the electrical failure which raised the system, the impacts of heavyweight and high speed aircraft rolling over the system caused problems in the support boxes. The down bumpers in the center 12 boxes were partially damaged (Figure 20) because they weren't designed to absorb this much energy.

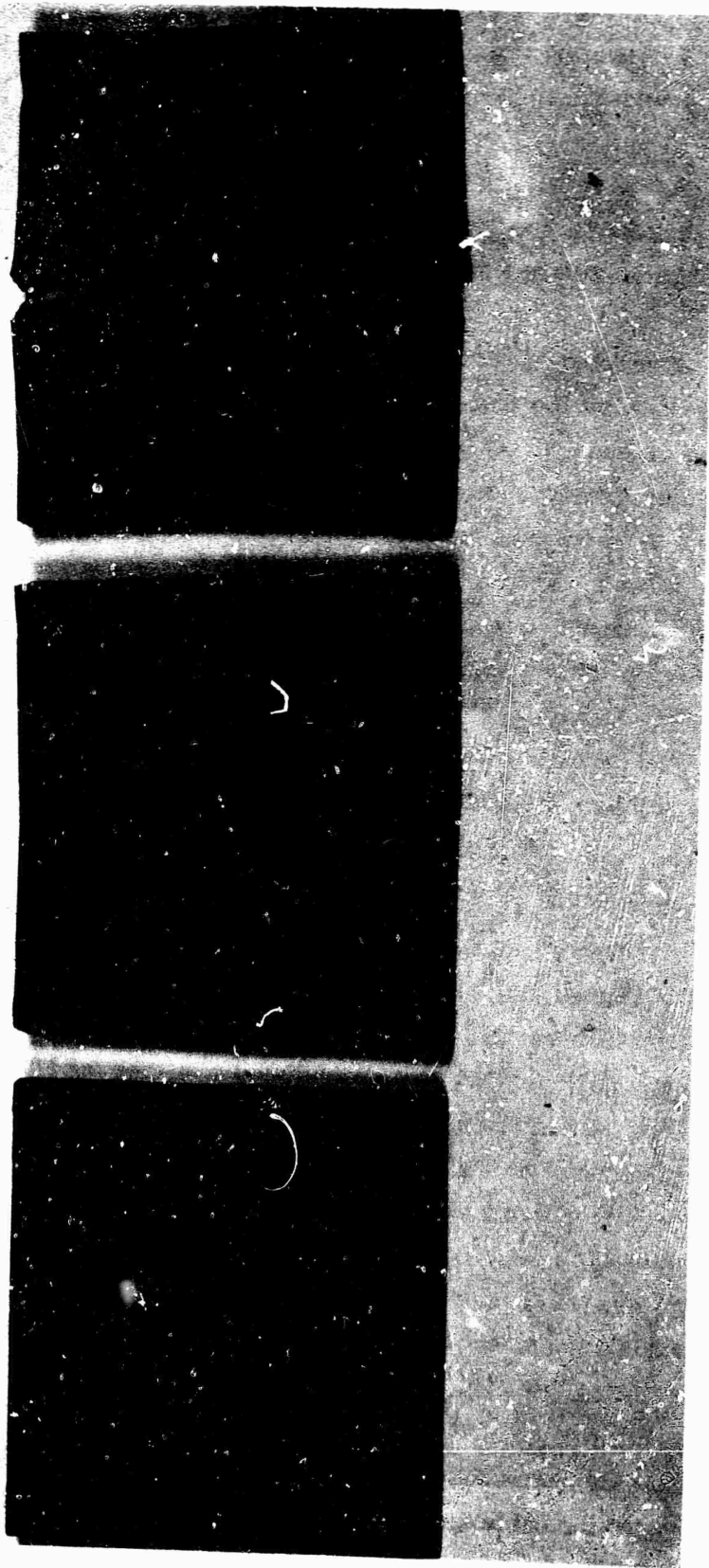

Figure 20. Various Stages of Down Bumper Deterioration

ASD-TR-69-9

As soon as the problems were found, the bumpers were rotated 90 degrees for a temporary fix. If this fix had not been performed, several cable support boxes would have been destroyed.

As a result of the damage, these pads were replaced with one inch thick 60 durometer neoprene pads, which proved satisfactory. Solving the electrical problems greatly aided in preventing box damage.

When the support arm impacts the down bumper, the energy should be absorbed by the pads. The original 1/2-inch thick pads were designed to withstand speeds of 130 knots, but many aircraft land down-wind and have a much greater ground speed at touchdown. If the pad is unable to absorb all the energy then the arm cuts through the bumper and metal to metal contact results and the support box or spring-arm assembly must absorb the remaining energy. It turned out that the energy still remaining was absorbed by deforming the 1/8-inch thick steel striker plate of the spring-arm assembly (Figure 21) which was built with a 7/8-inch outside radius. Although deformed, the plate still functioned as a striker and no damage was done to the support boxes because the problem was remedied before the striker plate could fail.

5. MISSED ENGAGEMENT

The first missed engagement occurred with the F-100 at 109 knots. The pilot started his high speed taxi and dropped his hook at 1,000 feet from the cable. After normal hook bounce had damped out, the hook contacted a semiflush centerline light (200 feet from the cable). The hook bounced and hit the aft end of the aircraft and continued bouncing until well past the cable. No further engagements were made at this location. All tests were moved 16 feet off-center. Type B blocks were used for this test.

The second missed engagement was with the F-106 at 127 knots. The Type C supports were used with just the breakaway portion of the support supporting the cable, approximately 1-inch above the runway. Photo interpretation revealed that there was a slight hook bounce, but most notably the cable dynamics were such that the cable was on the runway surface. The hook partially engaged the cable and did some damage to both the cable and the hook (Figure 22

ASD-TR-69-9



Figure 21. Striker Plate of Spring-Arm Assembly

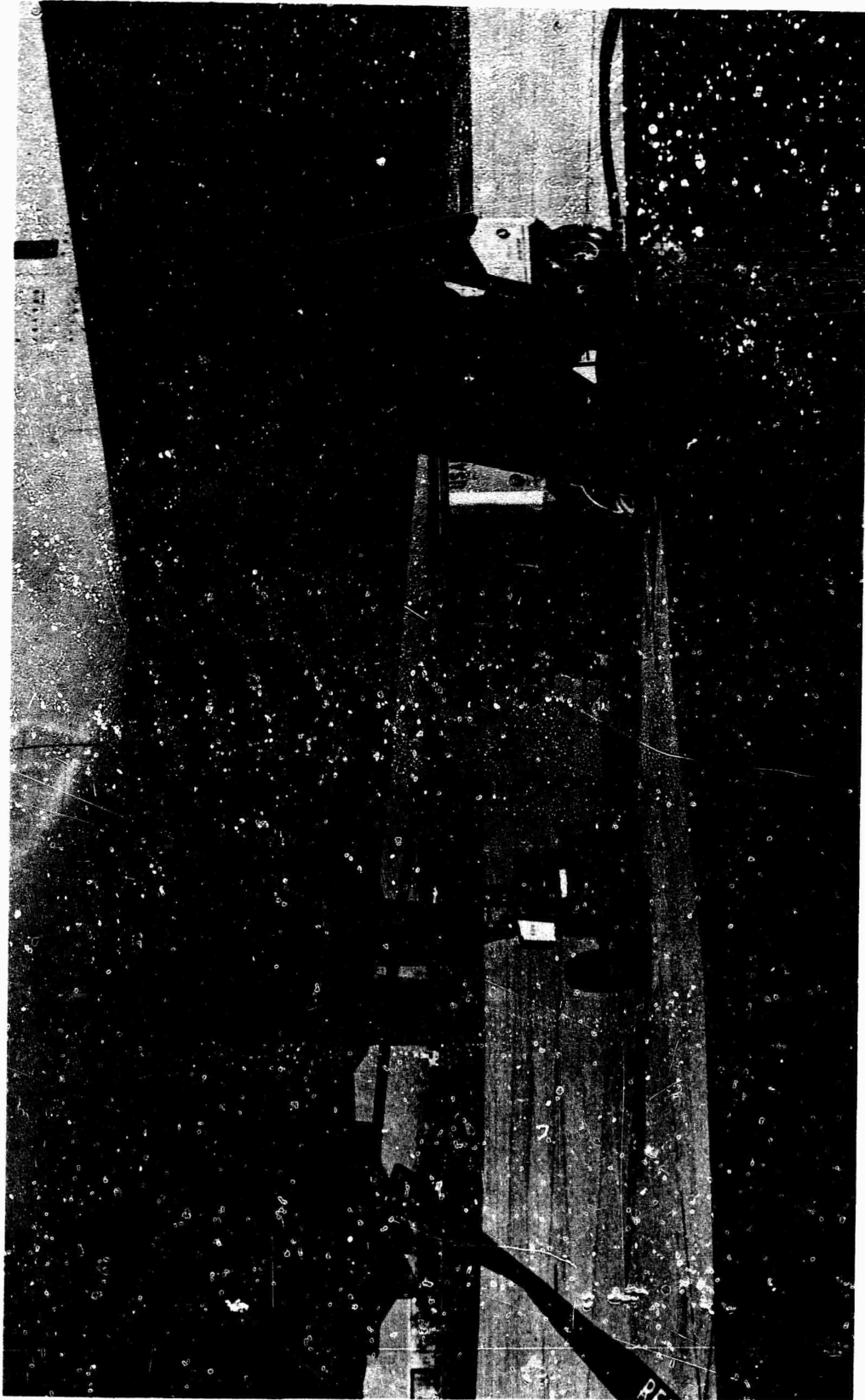

Figure 22. F-106 Hook After Missed Engagement

ASC-TR-69-9

and 23). From Figure 22 it can be seen that the leaf spring portion of the arresting hook was severely bent because of the whipping of the hook after impact with the cable. The wear plate portion of the hook shoe contacted the cable and was sheared off instantaneously (Figure 23).

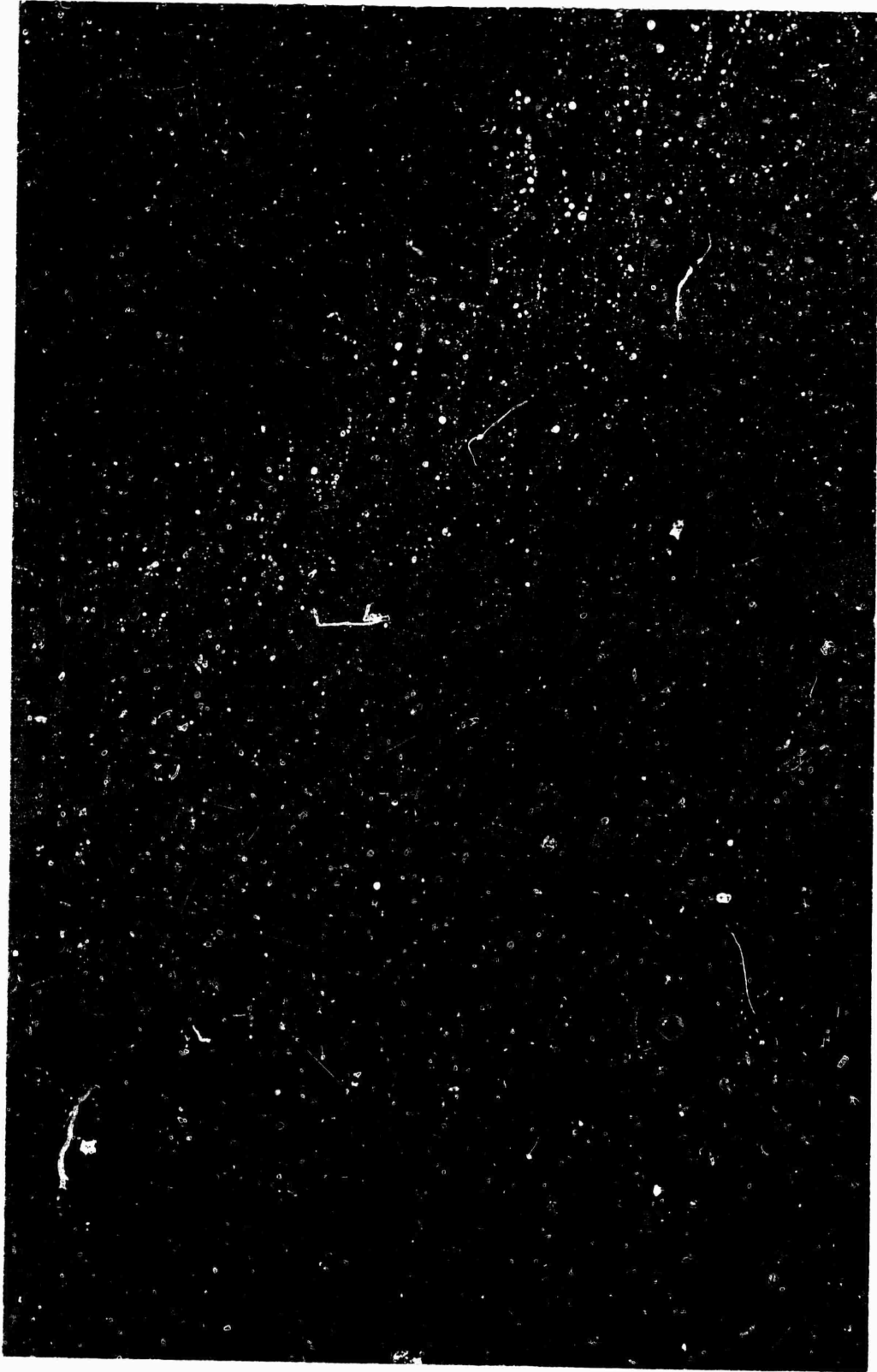

Figure 23. Damaged and Undamaged Wear Plates

SECTION VI CONCLUSIONS

Analysis of the test data indicated that the performance of the BAK-14 cable support system met or exceeded the specifications as indicated in SEMH Exhibit Number 65-4A, dated 10 August 1965.

Based on the limited tests at NAFEC and extrapolation of test data, the equipment will support an arresting cable for hook engagements of all aircraft. The system is compatible with all of the following USAF arresting systems: BAK-6, BAK-9, BAK-12, and BAK-13 if the proper adjustments are made for cable diameters. Both far end engagements and approach end engagements can be made with equal reliability.

The BAK-14 also satisfactorily kept the cable retracted into a cross-runway slot during heavy aircraft spin-ups. The arresting pendant and cable support life are greatly increased with this system. Arrestments are the only way that the components can wear out. The runway beneath the cable is preserved indefinitely because the cable cannot bounce on the surface.

Type A supports were the most satisfactory for BAK-14 use, but it is desirable that a metal base plate be imbedded into the block. With the proper modifications, these supports will have greatly extended service life and be able to survive many repeated arrestments.

BAK-14 adverse weather tests were unable to be conducted because the winter weather at NAFEC was too mild for satisfactory climatic tests. Thus, the ability of the thermostatic heaters, imbedded in the runway surface, to prevent ice formation in the support boxes was untested. However, if a BAK-14 installation should be required at a northern location, it would be perfectly acceptable to use de-icing fluid to prevent ice formation in any part of the system.

SECTION VII RECOMMENDATIONS

It is recommended that:

1. A retractable cable support system should be procured for the barrier test site at the Air Force Flight Test Center (AFFTC) in order that extensive hook engagements can be performed.
2. The support boxes should be installed at least ten feet from the edge of the runway on each side.
3. Type A supports should be used but a metal base plate should be installed to prevent block destruction at the anchorage points.
4. Type A supports should be constructed of a material which will easily withstand fatigue such as polyurethane or softer neoprene.
5. The cross-runway slot should be lined with a metal trough.
6. Efforts should be made to increase the off-center distance between the raised cable centerline and the slot centerline.
7. The BAK-14 should be studied and slightly redesigned for use with the operational concept of recovering all fighter aircraft.
8. Different types of position indicating switches should be used. These switches should not be affected by heavyweight and high speed rollovers.
9. Heaters should be used which are capable of melting snow on the surface of the runway in the vicinity of the cable.
10. The retractable system should be used on all runways where the arresting cable is presently located on the active runway and is damaging either the runway because of cable bounce or damaging aircraft rolling over the cable.

ASD-TR-69-9

11. Adverse weather tests should be conducted at an appropriate site to ensure system operation under the most severe weather conditions.

APPENDIX I

RETRACTABLE CABLE SUPPORT TEST DATA

Test Event	Date	Aircraft Type	Engaging Speed (Knots)	Type Test	Hook Position	Remarks
PHASE I						
1	30 Sep 66	F-100	98	Rollover	34"L #6	Cable bounced out of #7 support block
2	30 Sep 66	F-100	80	Rollover	30"L #6	Cable bounced out of #6 support block
3	30 Sep 66	F-100	120	Rollover	33"L #6	Wind gusts - 30 knots
4	30 Sep 66	F-100	115	Rollover	36"L #7	
5	1 Oct 66	F-100	100	Engage	1"L #11	#9, #10, #11 blocks were damaged
6	1 Oct 66	F-100	120	Engage	46"L #11	Hook damaged aircraft
7	4 Oct 66	F-100	80	Engage	Contact #11	#11, #12 blocks were damaged
8	4 Oct 66	F-100	65	Engage	2"L #11	
9	4 Oct 66	F-100	80	Engage	22"L #11	
PHASE II						
10	22 Mar 67	F-100	70	Engage	28"R #10	
11	23 Mar 67	F-100	100	Engage	Contact #10	#9, #10, #11 had to be removed
12	23 Mar 67	F-100	109	Engage	2"L #13	Hook bounced over cable
13	23 Mar 67	F-100	107	Engage	1"L #10	
14	24 Mar 67	F-100	100	Engage	25R #10	#9 damaged; fatigue cracks developing in supports
15	24 Mar 67	F-100	108	Engage	38"L #10	#9 damaged; fatigue cracks developing in supports

Preceding page intentionally
left blank

Test Event	Date	Aircraft Type	Engaging Speed (Knots)	Type Test	Hook Position	Remarks
16	24 Mar 67	F-100	108	Engage	1"L #10	
17	24 Mar 67	F-100	71	Engage	36"L #11	
18	28 Mar 67	F-106	60	Engage	11"R #11 Contact #11	
19	29 Mar 67	F-106	80	Engage	11"R #11	
20	30 Mar 67	F-106	100	Engage	Contact #11	
21	30 Mar 67	F-106	127	Engage	Contact #11	Hook bounced over cable
22	30 Mar 67	F-106	107	Engage	73"L #10	
23	30 Mar 67	F-106	120	Engage	42"L #11	
PHASE III						
24	1 Oct 68	F-101	80	Rollover	Undetermined	
25	1 Oct 68	F-101	100	Rollover	Undetermined	
26	2 Oct 68	F-101	110	Rollover	4"L #11	Concrete slot chipping
27	2 Oct 68	F-101	120	Rollover	1"L #10	
28	2 Oct 68	F-101	Est 35	Rollover	Undetermined	Rollover made in opposite direction
29	3 Oct 68	A-4D	80	Engage	48"L #10	#10 and #11 blocks broken
30	3 Oct 68	A-4D	100	Engage	48"L #10	#10 and #12 damaged
31	3 Oct 68	A-4D	120	Engage	48"L #10	#12 damaged

APPENDIX II

STATIC TESTS OF SUPPORT BLOCKS

1. TEST PROCEDURE

These tests were conducted to determine the relative cable gripping characteristics of the pendant support blocks and to check the block attachment.

The procedure was to install the support block on a test fixture (Figure 24) which was retracted to simulate the system in the retracted position. A one inch diameter bar was inserted into the cable hole and pulled until the block shed the bar. The bar motion was measured at various load points.

Both slit and unslit supports were pull tested. The slit was cut in the top of the block for cable insertion.

2. TYPE A STATIC TEST

The leading edge of the slit Type A support failed by tearing before 1 1/2 inches of deflection was recorded (Figure 25). This premature tear resulted because the block had been improperly cured. However, observation during the test indicated that it would have shed the cable even if it hadn't torn.

An unslit Type A support was also tested. It pulled out of its anchorage in a visually similar manner to those blocks which straddled the arresting hook during an engagement (Figure 26). After the test the partially pulled out block was slightly difficult to remove, as were those at NAPEC.

3. TYPE B STATIC TEST

The slit support was able to provide a 50 percent greater cable gripping characteristic (Figure 27) than the Type A supports.

The unslit supports retained the cable after full deflection of the test fixture (Figure 28). Failure started by tearing the rubber on the tension side of the attachment plate. The tear propagated through the cylindrical portion of the neoprene and extended through the attachment plate, while

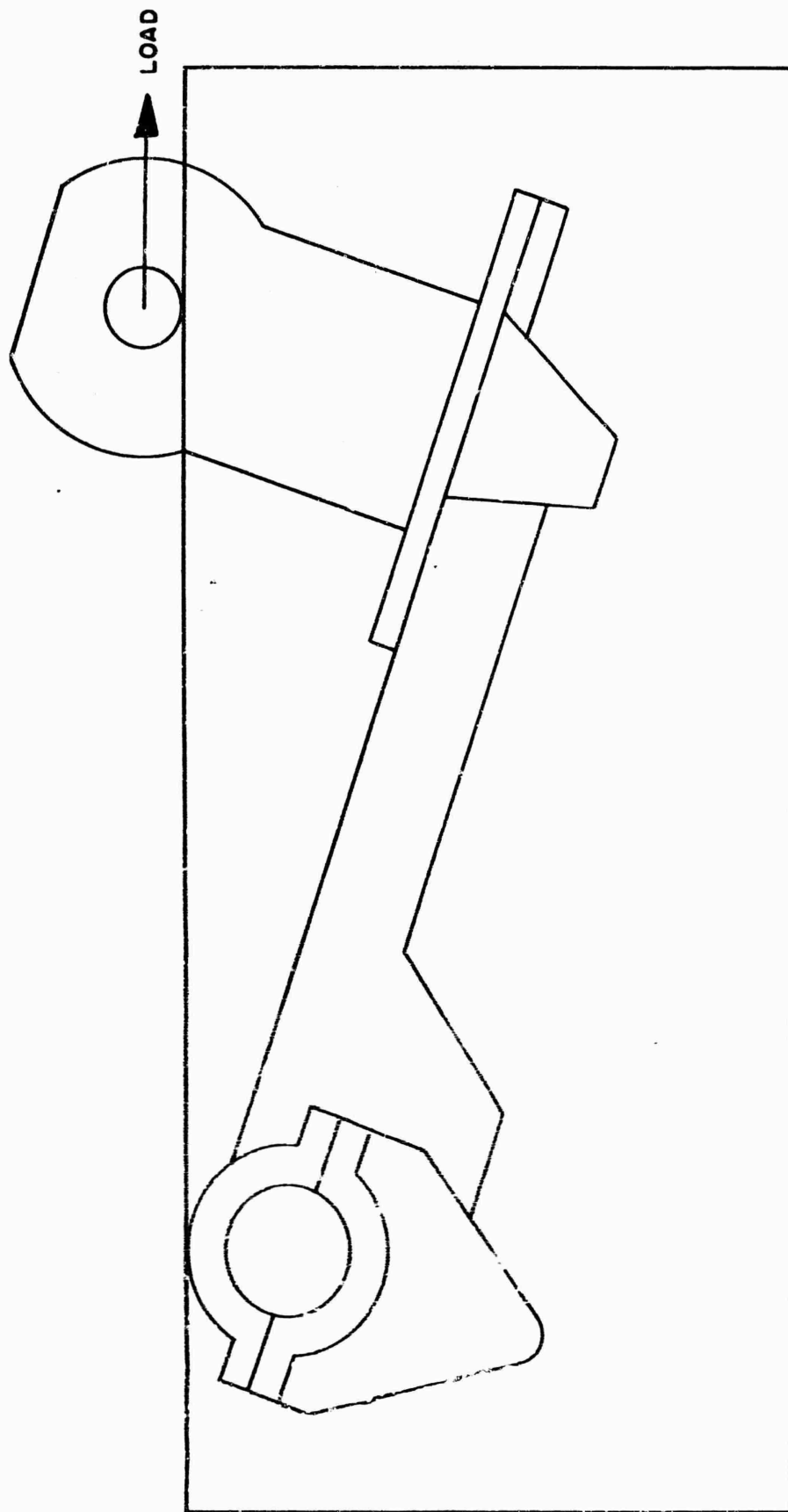

Figure 24. Static Test Set-Up

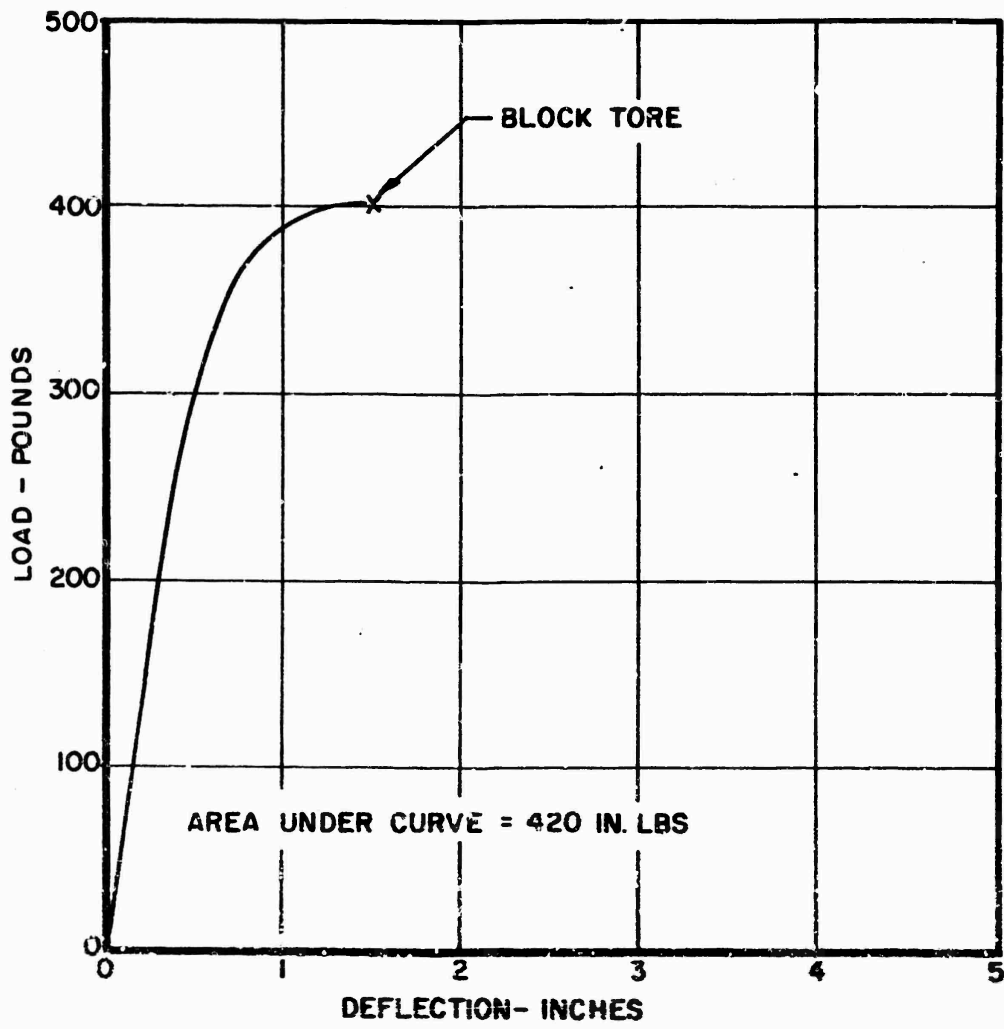

Figure 25. Deflection Curve for Slit Type A Support Blocks

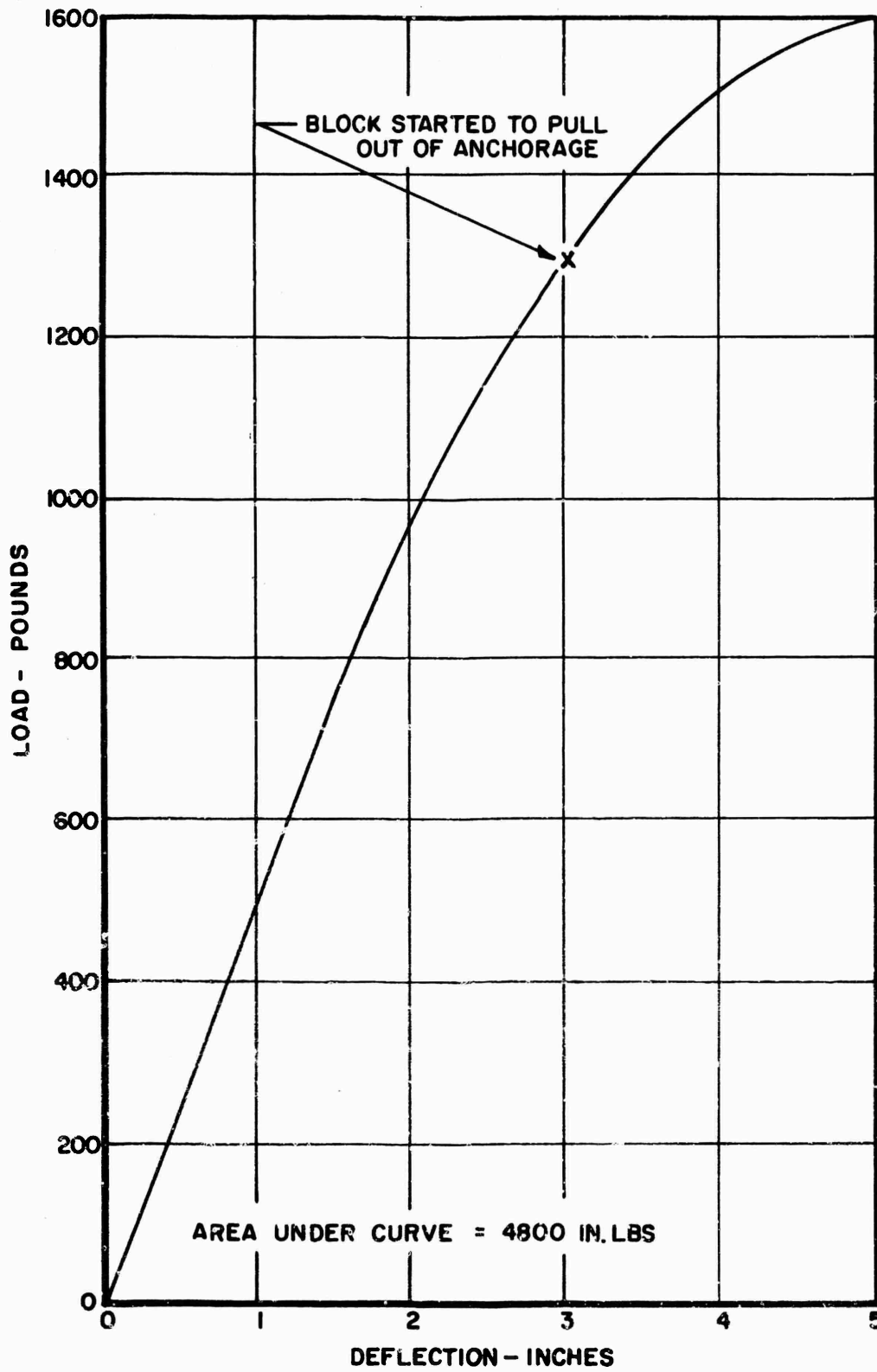

Figure 26. Deflection Curve for Unslit Type A Support Blocks

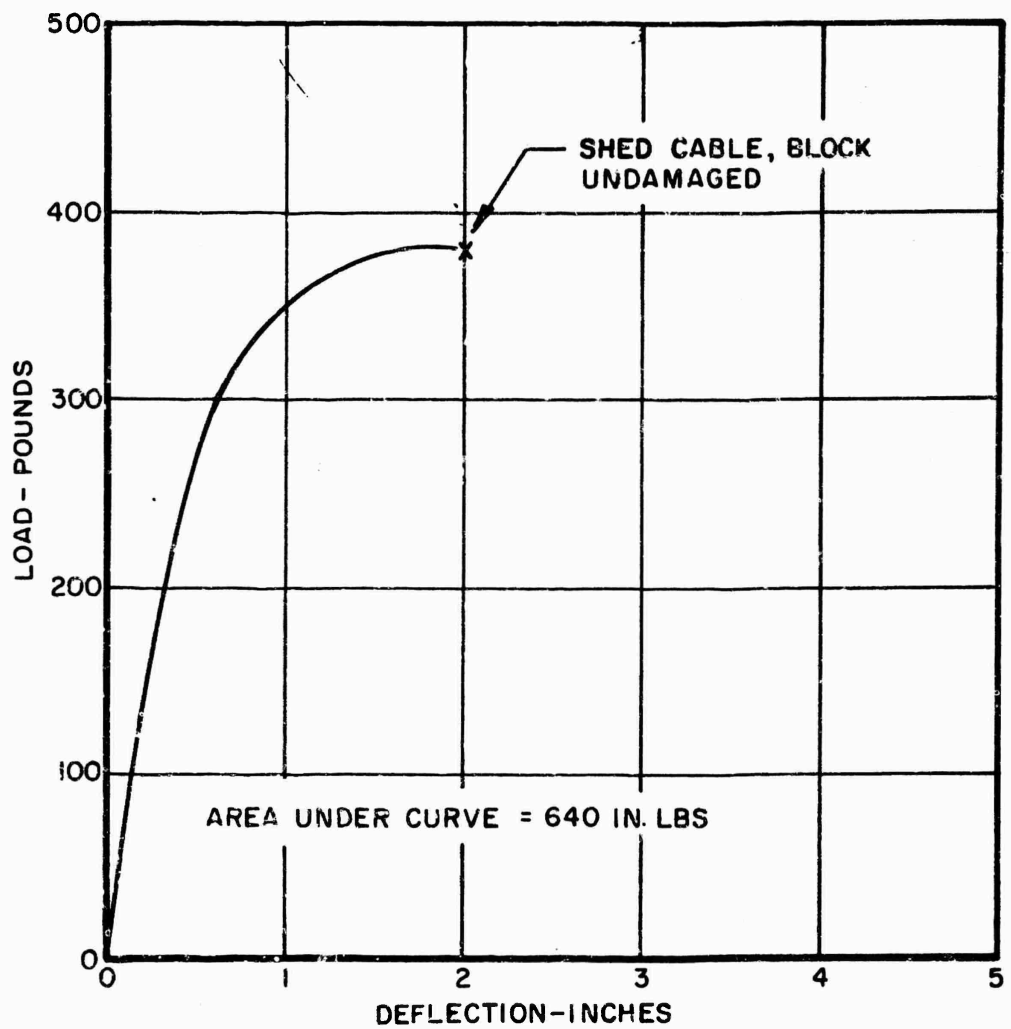

Figure 27. Deflection Curve for Slit Type B Support Blocks

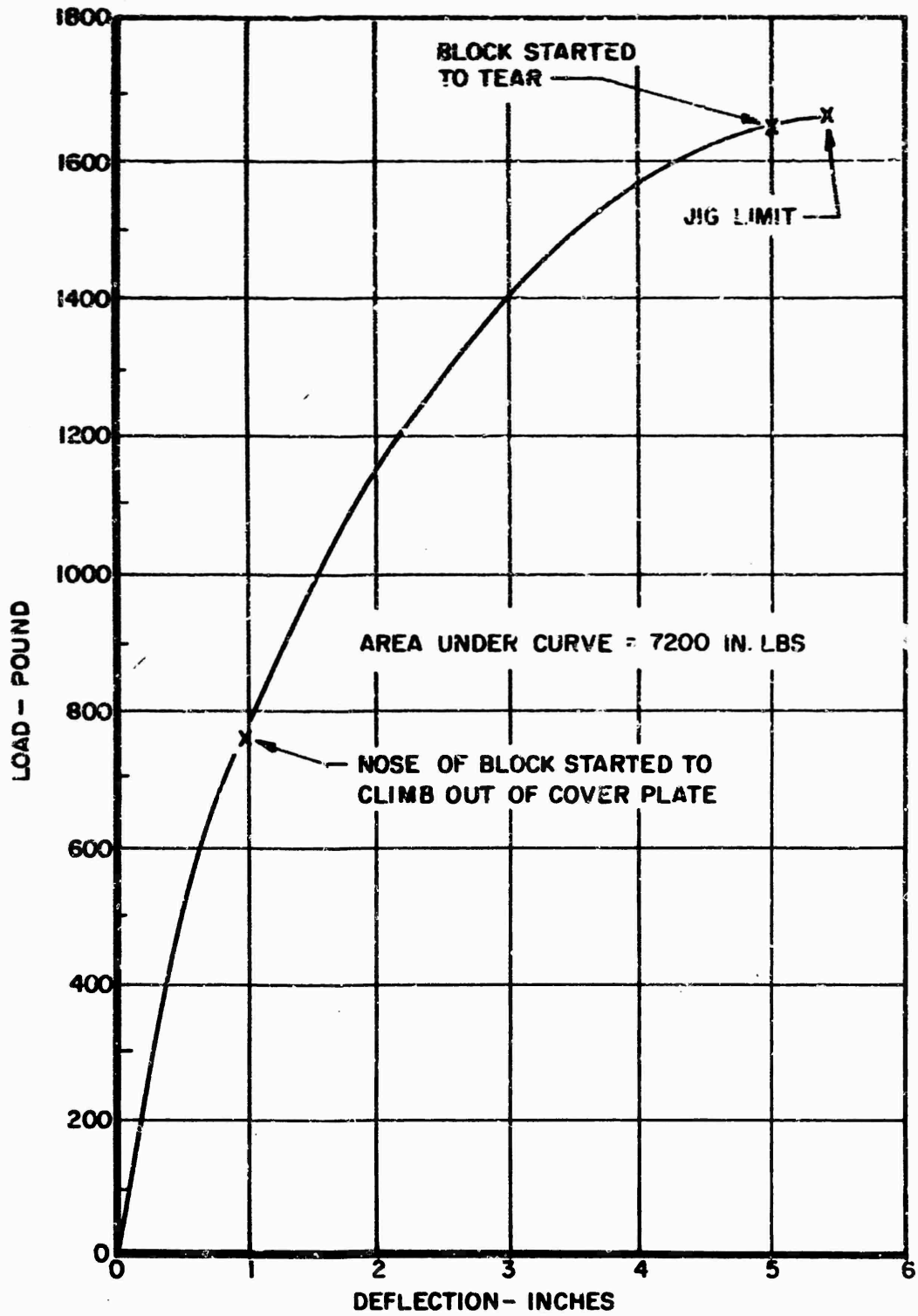

Figure 28. Deflection Curve for Unslit Type B Support Blocks

ASJ-TR-59-9

holding full load. The new attachment (imbedded steel plate) was undamaged after the block had been torn off and was readily replaced.

4. TYPE C STATIC TEST

Two tests were conducted with the Type C supports. One test was with a block that had a 1/4 inch sawcut around the breakaway portion and the other test was with the support which had no sawcut, only the molded groove around the breakaway portion.

These supports were only two inches wide and made of 50 durometer hardness neoprene. The other supports were wider and made of harder rubber (60 durometer).

With the sawcut added, the block flexibility was further increased and the failure occurred along the slot. When this failure started, it slowly progressed along the slot until it became complete. Thus a perfect donut was left. However, the price for achieving this failure is a sizeable reduction in holding power (Figure 29).

The uncut Type C support failed at its attachment plate, similar to the unslit Type B supports (Figure 30).

5. SUMMARY OF TEST DATA

The relative holding power of the six configurations tested can be expressed by the relative areas under the load-deflection curves.

<u>Support Block</u>	<u>Area under Load Deflection Curve</u>
Type A	420 in. lbs
Type A (unslit)	4800 in. lbs
Type B	640 in. lbs
Type B (unslit)	7200 in. lbs
Type C	1820 in. lbs
Type C (sawcut)	1260 in. lbs

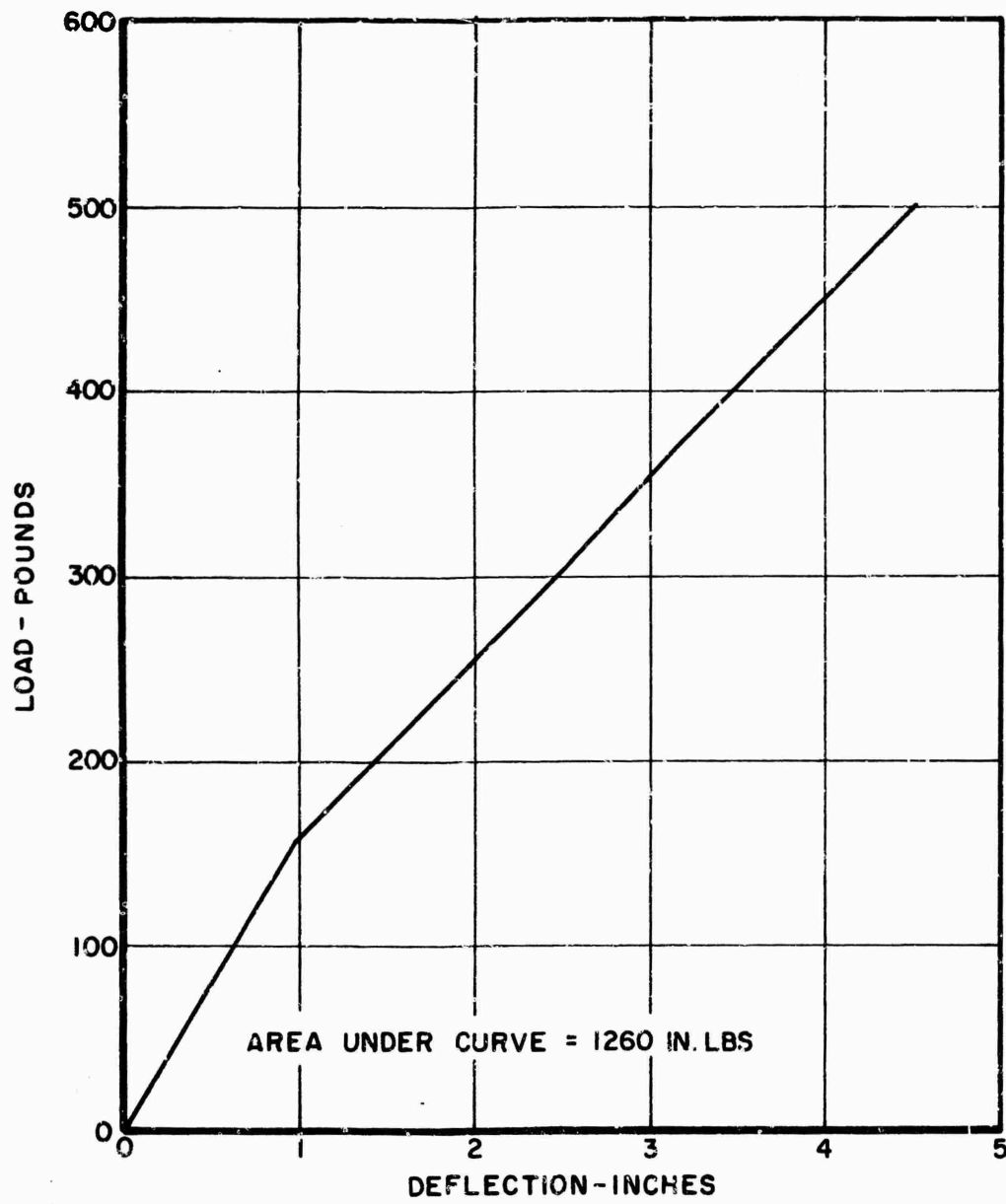

Figure 29. Deflection Curve for Slit Type C Support Blocks

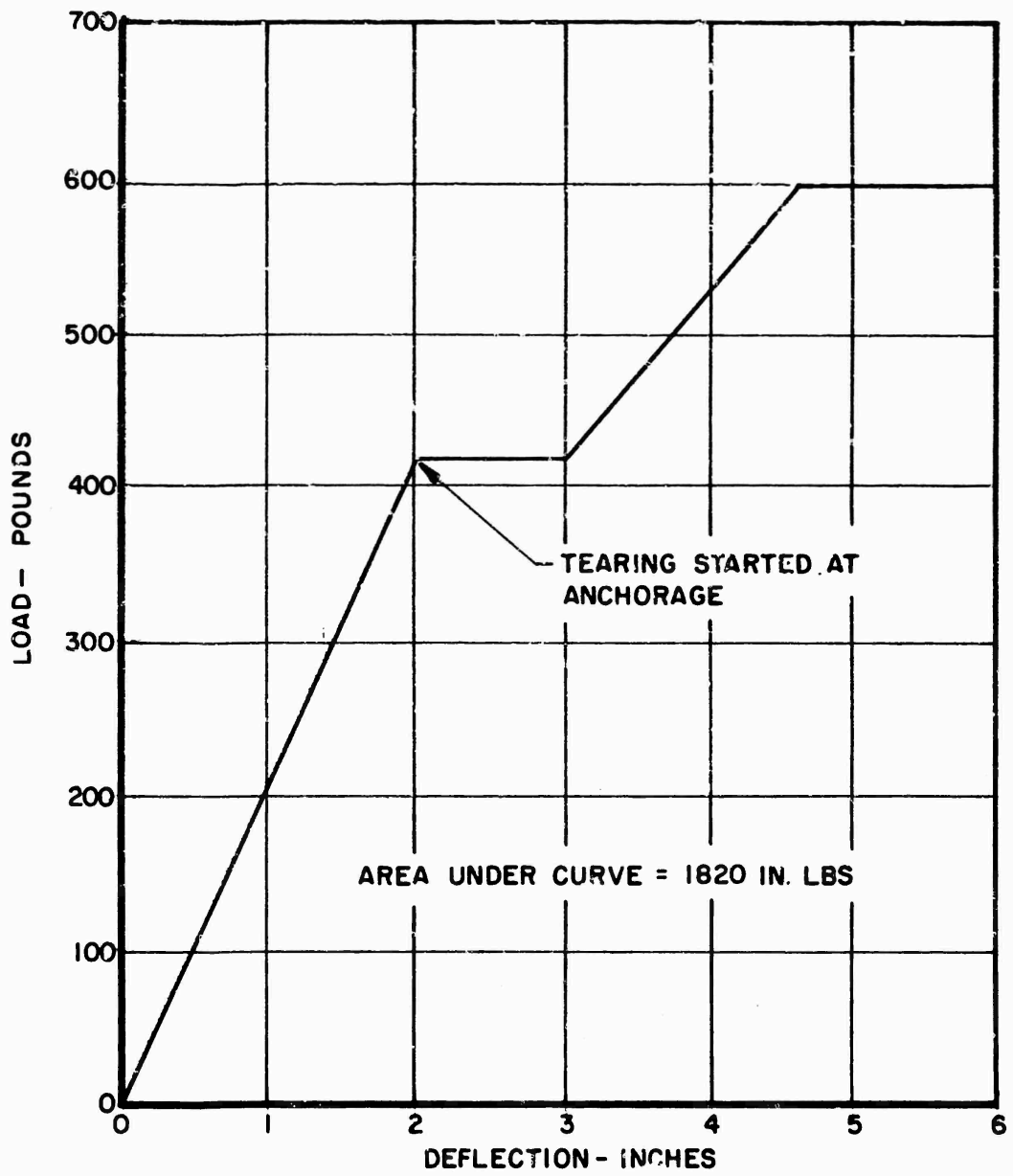

Figure 30. Deflection Curve for Unslit Type C Support Blocks

ASD-TR-69-9

It should be noted that this test data is relative only, and not absolute. The behavior of the rubber blocks under very slowly applied loads is probably quite different from its behavior under very high speed impacts.

The area under the load deflection reflects the ability of the support to retain the cable.

APPENDIX III

STATIC TEST OF POLYURETHANE SUPPORT BLOCK

The gripping characteristics of the previous cable support blocks (Types A, B, and C) were marginal or submarginal.

The contractor believed that with further effort, blocks could be developed with improved gripping characteristics. At the contractor's expense, various configurations of additional support blocks were obtained for trials. The most promising of these configurations was a 60 durometer polyurethane block similar to the Type C block except the hole diameter was increased to 1 3/8 diameter and the circular sawcut was eliminated.

Having no experience with this material, we considered it desirable to test one of these new blocks in the same manner as those tested in Appendix II. The load-deflection curve of this test is shown in Figure 31. The test was stopped at 6-inch deflection at the jack stroke limit.

During the test, there was no tearing of the material from its metal base, as occurred with the neoprene.

After the test no set was evident. The block appeared to be still useful for service test.

The test results showed:

- a. The modulus of elasticity of the polyurethane was slightly lower than that of the neoprene, resulting in a more flexible block.
- b. The toughness of the polyurethane was far greater than that of neoprene. This can be reflected by the ratios of the areas under the load deflection curves. The area for the polyurethane support was greater than the closest neoprene support.

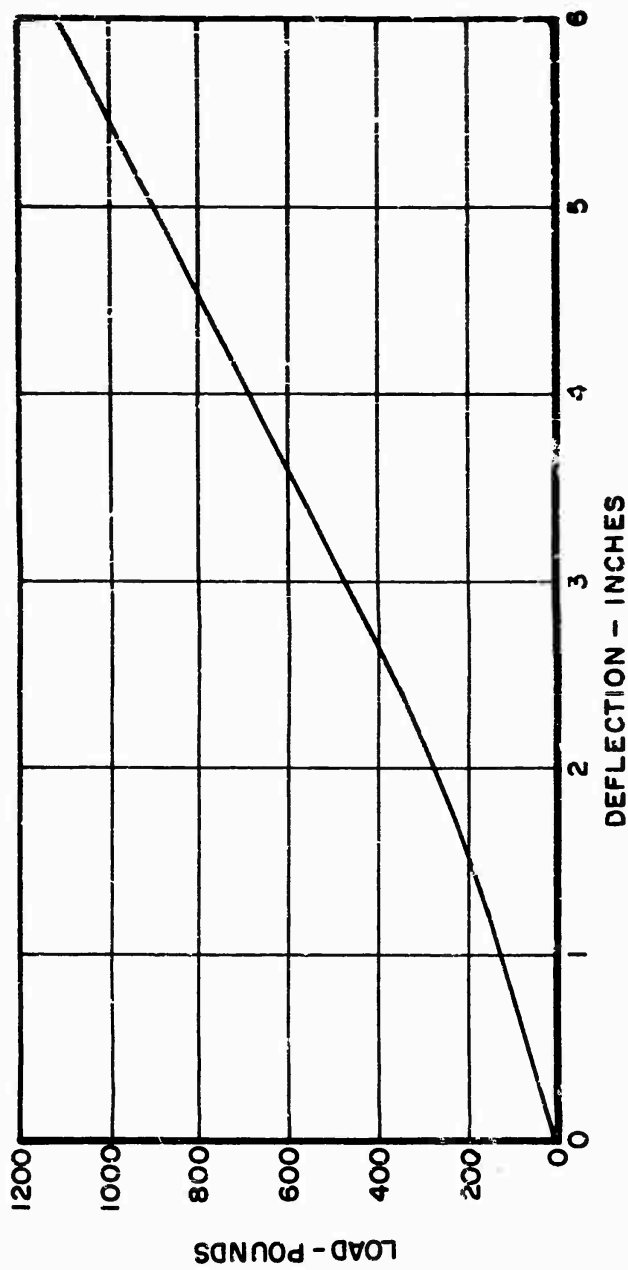

Figure 31. Deflection Curve for Polyurethane Type C Support Blocks

UNCLASSIFIED

Security Classification

DOCUMENT CONTROL DATA - R & D

(Security classification of title, body of abstract and indexing information must be entered when the overall report is classified)

1. ACTIVITY (Date author) Deputy For Engineering Aeronautical Systems Division Wright-Patterson Air Force Base, Ohio		2a. REPORT SECURITY CLASSIFICATION Unclassified
3. REPORT TITLE BAK-14/F32 RETRACTABLE CABLE SUPPORT SYSTEM		2b. GROUP
4. DESCRIPTIVE NOTES (Type of report and inclusive dates)		
5. AUTHOR(S) (First name, middle initial, last name) Wolfe, Alex V., 1st Lieutenant, USAF		
6. REPORT DATE August 1969	7a. TOTAL NO. OF PAGES 76	7b. NO. OF REFS
8a. CONTRACT OR GRANT NO.	8b. ORIGINATOR'S REPORT NUMBER(S) ASD-TR-69-9	
b. PROJECT NO. 921A-9269	9b. OTHER REPORT NO(S) (Any other numbers that may be assigned to a report)	
c.		
d.		
10. DISTRIBUTION STATEMENT This document has been approved for public release and sale; its distribution is unlimited.		
11. SUPPLEMENTARY NOTES	12. SPONSORING MILITARY ACTIVITY Deputy For Engineering Aeronautical Systems Division Wright-Patterson Air Force Base, Ohio	
13. ABSTRACT This report presents the result of a development and test program to evaluate the BAK-14/F32 Retractable Cable Support System and all of its components. A total of nine rollovers and twenty successful engagements were accomplished using the F-100, F-101, F-106, and A-4D aircraft. The objectives of the program were to: a) Determine the engaging reliability with aircraft arresting hooks. b) Analyze the restraint characteristics of the support blocks when aircraft touch down on the cable. c) Prevent damage to private and commercial aircraft during rollover. The test results demonstrated that the BAK-14 was compatible with the BAK-9 arrestor and that the BAK-14 concept was compatible with all arrestors which utilize cross-runway cables. The test results also indicated that the system could be engaged bidirectionally with equal reliability. The installation was comprised of 24 identical cable support boxes, each separated by eight feet. In operation, when the system was retracted, the control tower or runway edge operator actuated an electrical valve which permitted high pressure air to be ducted into the air cylinder of each support box forcing the special forked arm, linking the spring-arm assembly and the air cylinder, to twist the torsion spring such that it retracted the cable into a cross-runway slot in approximately eight seconds. When the system was raised, the three-way		

DD FORM 1 NOV 68 1473

UNCLASSIFIED

Security Classification

UNCLASSIFIED
Security Classification

14. KEY WORDS	LINK A		LINK B		LINK C	
	ROLE	WT	ROLE	WT	ROLE	WT
Retractable Cable Support System Arresting System Arresting Cable Supports						

UNCLASSIFIED
Security Classification

13. ABSTRACT (Cont'd)

valve was opened and air was released to the atmosphere causing the fork fitting to withdraw into the air cylinder, and the torsional spring returned the spring-arm assembly to the raised position in approximately five seconds. ()