

AD 696 400

BONDING OF FLAT ICE SURFACES. SOME PRELIMINARY RESULTS

H. H. G. Jellinek

Snow Ice and Permafrost Research Establishment
Wilmette, Illinois

July 1960

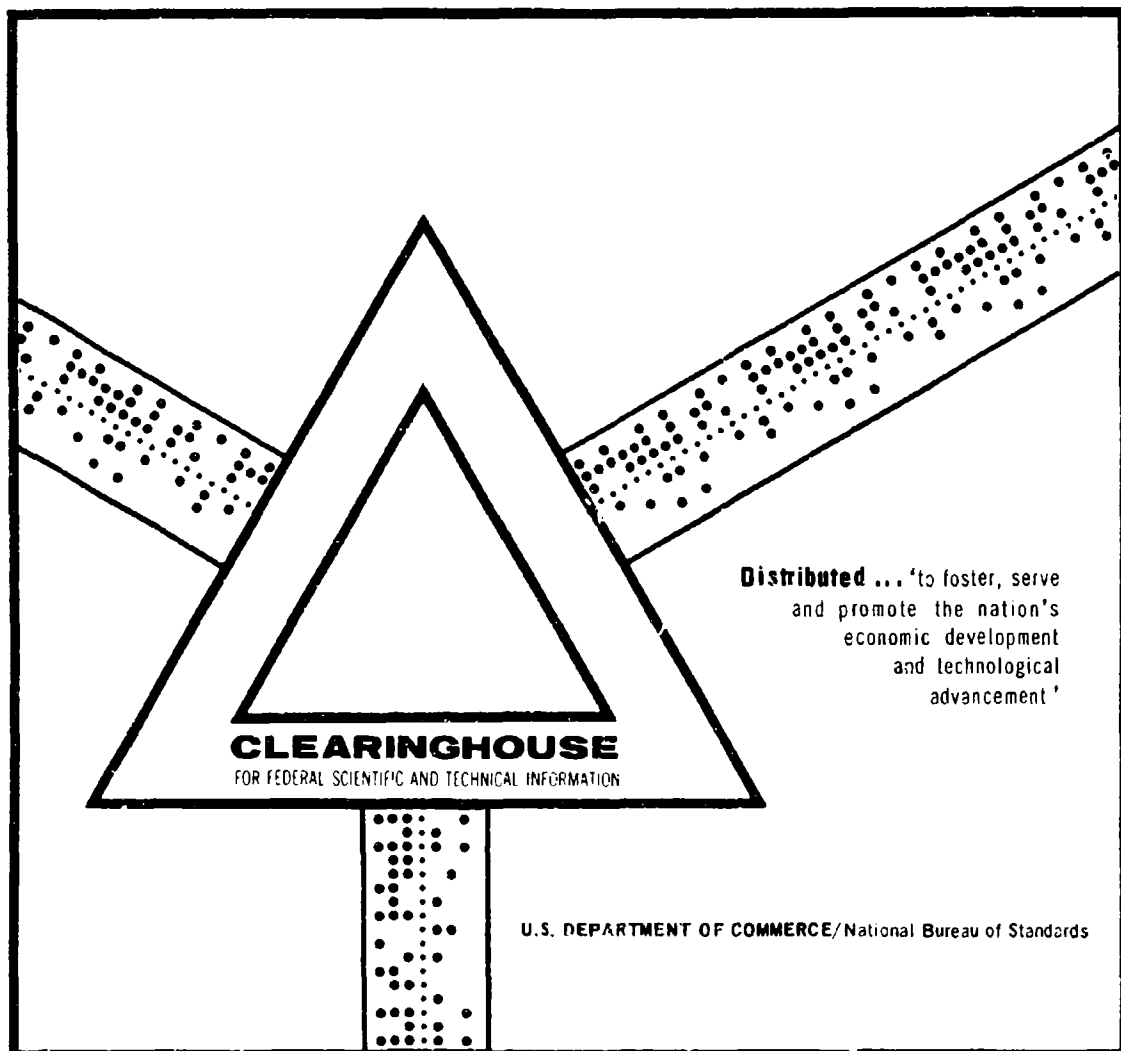

This document has been approved for public release and sale.

Research Report 61

JULY, 1960

Bonding of Flat Ice Surfaces

Some Preliminary Results

by H. H. G. Jellinek

**U. S. ARMY SNOW ICE AND PERMAFROST
RESEARCH ESTABLISHMENT**

Corps of Engineers

Wilmette, Illinois

PREFACE

This is one of a series of reports of work performed on USA SIPRE Project 22.1-4, Thickness and strength of ice surface layers. The purpose of these investigations is to study the cause and mechanism of bonding ice surfaces.

The work was performed by Dr. H. H. G. Jellinek, physical chemist, Snow and Ice Basic Research Branch. The tests were performed by S. Mock. Work on this project was performed for USA SIPRE's Snow and Ice Basic Research Branch, Mr. J. A. Bender, acting chief.

This report has been reviewed and approved for publication by the Office of the Chief of Engineers.

WILLIAM L. NUNGESEER
Colonel, Corps of Engineers
Director

Manuscript received 15 July 1959

Department of the Army Project 8-66-02-400

CONTENTS

	Page
Preface	ii
Summary	iv
Introduction	1
Materials	1
Apparatus and procedure	1
Results	3
Discussion	5
References	6
Appendix: Compression of an assembly of cylinders	A1

ILLUSTRATIONS

Figure	Page
1. Jig for bonding ice cylinders	2
2. Mean strength values vs load, exerted for 60 min.	2
A1. Deformation vs time	A4
A2. Deformation vs load	A4
A3. Force of rupture vs load	A4

TABLES

Table	Page
I. Cylinders polished on quartz optical flat	3
II. Cylinders with surfaces microtomed	4

SUMMARY

Experiments have been performed on the bonding of polished and microtomed ice surfaces at -5°C . These surfaces showed an appreciable curvature and unevenness. The force of separation after bonding for 60 min under different weights increased with weight. The surfaces placed together immediately after preparation showed an appreciably higher force of separation than those placed together after a time interval. The force of separation for surfaces placed together at zero humidity showed a higher force of separation than those placed together in an atmosphere of 100% relative humidity.

A preliminary simplified theory of bonding of irregular surfaces has been developed.

SOME PRELIMINARY RESULTS ON THE BONDING OF FLAT ICE SURFACES

by

H. H. G. Jellinek

Introduction

A preliminary investigation of the bonding of flat ice surfaces under various conditions was undertaken. If satisfactory optically flat ice surfaces could be prepared, such experiments would throw some light on the phenomenon of regelation, a subject of controversy for a long time. Faraday (1859; 1860) postulated the existence of a liquidlike layer on the surface of ice below its melting point about one hundred years ago. This layer was assumed to be responsible for the fusing together of two pieces of ice when touching each other under a very slight pressure. This assumption was disputed by Thomson (1859) who held the view that some pressure melting takes place, however small the pressure, leading to liquid films which would cause fusion. This is the view usually found in the literature. Recent experiments, however, indicate that the pressure melting theory is no longer acceptable and that Faraday's views are probably correct. The pressure required to reduce the melting point by even a small amount is quite appreciable. Nakaya and Matsumoto (1953) have shown by experiments with suspended ice spheres slightly touching each other that they behave as if a liquidlike layer was present on their surfaces. Similar experiments were carried out by Hosler, Jensen, and Goldshlak (1957) on a more quantitative basis. They measured the force necessary to separate two ice spheres in a water-vapor saturated atmosphere and an atmosphere of very low humidity. The results showed that the force holding the spheres together in the saturated atmosphere was still measurable at a temperature of -25°C , whereas the force became negligible at -3°C in an atmosphere of very low humidity.

Weyl (1951) has discussed the liquidlike layer on ice from a theoretical point of view in connection with the dipole nature of the water molecule. Results obtained by Jellinek (1957a) on the adhesive properties of ice can also be satisfactorily explained by the assumption of a liquidlike layer present not only at an ice/air interface but also at interfaces of ice/metal or other solid materials such as polymers.

The present experiments were carried out with the hope of obtaining a more quantitative measure of the forces required to separate two pieces of ice frozen together under various conditions. The experiments by Nakaya and Jensen provide only a rough estimate of the interfacial areas so that proper tensile strength values were not obtained.

The experimental approach in this work was an attempt to obtain two optically flat ice surfaces and to freeze them together below 0°C under various conditions. The results reported are only preliminary and show that it is very difficult to obtain really flat ice surfaces by hand-polishing on an optically flat quartz disc.

Materials

Bubble-free ice was obtained by freezing distilled water in a metal trough, which was placed on a cold plate (at about -20°C) in a room having a temperature of about $+16^{\circ}\text{C}$. In this way, the air was driven ahead of the advancing ice/water interface and an appreciable amount of air free ice was obtained.

Apparatus and procedure

Ice cylinders of 3.54 cm diam were prepared on a lathe at -10°C . Cylinders of 1 to 2 cm length were sandwiched between two stainless steel disks and cut in half. Each surface was planed with a microtome.

Next, the ice cylinder surfaces were polished on a quartz optical flat (round, single surface, 14.92 cm diam flat within 2.5×10^{-6} cm, obtained from the Do-All Company) in an attempt to obtain optically flat ice surfaces. A polishing turntable was constructed to hold the quartz flat, which could rotate at a speed of 25 rpm. Polishing was carried out at -10°C . The optical flat was carefully cleaned with benzene and methanol (reagent grade) before each polishing operation. The ice cylinder, contained in a Teflon ring for stability, was slightly pressed by hand

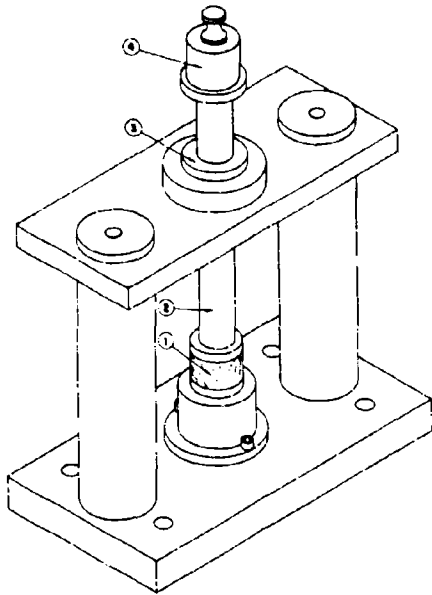

Figure 1. Jig for bonding ice cylinders. A metal frame holds a vertical stainless steel rod (2) which moves in a Teflon sleeve (3). A cylindrical cavity at the lower end of the rod receives the stem of one of the stainless steel disks to which one half of the original ice cylinder (1) is frozen. The stem of the second steel disk holding the other half of the ice cylinder is placed into a cavity directly below. A weight (4) can be placed on the platform attached to the stainless steel rod.

against the quartz surface and movements describing a figure 8 were carried out while the turn table rotated. The ice cylinder was also rotated around its own axis repeatedly.

The polished ice cylinders were then transferred into a thermostated box, which was kept at a temperature of $-0.5 \pm 0.1^{\circ}\text{C}$. This box was thermostated in the usual way (cooling coil supplied with prethermostated brine, heater, fan, and regulator relay; long rubber gloves tightly fitted to the front wall allowed manipulation without opening the box). The ice cylinders were either kept in the box 15 min before placing them together, or they were put together immediately by means of a special jig (Fig. 1), which assures that the two ice cylinders are lined up accurately while placing them together. The atmosphere was kept saturated by covering the floor of the box with snow. For work in an almost dry atmosphere, the snow is removed and a bowl containing sulfuric acid is placed in the box.

After an hour, the bonding between the two ice cylinders was measured at -5°C by means of a tensile strength apparatus. This apparatus was described in a previous report by Jellinek (1957b).

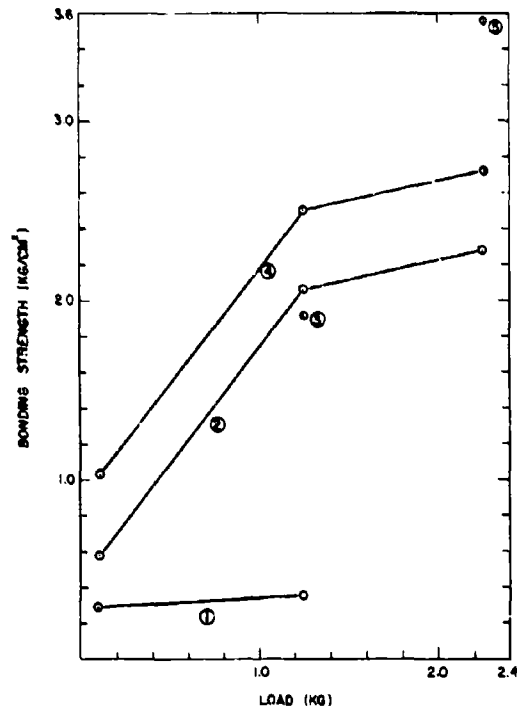

Figure 2. Mean bonding strength vs load, exerted for 60 min. Circled numbers indicate test conditions: 1. Polished cylinders placed together after 15 min in box. Saturated atmos. 2. Polished cylinders placed together immediately. Saturated atmos. 3. Cylinders with microtomed surfaces, placed together after 15 min in box. Relative humidity 100%. 4. Cylinders with microtomed surfaces, placed together after 15 min in box. Relative humidity near 0%.

Results

The results are given in Tables I and II. Figure 2 shows the mean strength values plotted as a function of the load, which was exerted for 60 min.

Table I. Cylinders polished on quartz optical flat.

Temp: $-0.5 \pm 0.1^{\circ}\text{C}$. Cross-sectional area of cylinders: 5.56 cm^2 .
Time of contact of ice surfaces: 60 min. Saturated atmosphere.

(a) Wt on cylinders: 117.9 g. Cylinders placed together immediately.

Test no.	Force of rupture	
	Total (kg)	(kg/cm ²)*
1	3.0	0.54
2	4.5	0.81
3	0	0
4	2.0	0.36
5	0	0
6	<u>9.8</u>	<u>1.76</u>
	Mean 3.2	Mean 0.58

(b) Wt on cylinders: 117.9 g. Placed together after 15 min in box.

1	0.8	0.15
2	0.5	0.09
3	5.1	0.92
4	1.7	0.31
5	0.17	0.03
6	<u>1.4</u>	<u>0.25</u>
	Mean 1.6	Mean 0.29

(c) Wt on cylinders: 1250 g. Cylinders placed together immediately.

1	10.1	1.8
2	10.2	1.8
3	14.5	2.6
4	8.5	1.5
5	21.3	3.8
6	<u>4.5</u>	<u>0.8</u>
	Mean 11.5	Mean 2.1

(d) Wt on cylinders: 1250 g. Placed together after 15 min in box.

1	3.3	0.60
2	2.6	0.46
3	0	0
4	2.3	0.42
5	2.7	0.48
6	<u>1.3</u>	<u>0.23</u>
	Mean 2.0	Mean 0.36

(e) Wt on cylinders: 2252 g. Cylinders placed together immediately.

1	34.5	6.2
2	10.1	1.8
3	9.5	1.7
4	7.6	1.4
5	10.4	1.9
6	<u>3.6</u>	<u>0.65</u>
	Mean 12.6	Mean 2.3

* Based on cross-sectional area of cylinders.

BONDING OF FLAT ICE SURFACES

Table II. Cylinders with surfaces microtomed, but not polished.

Temp: $-0.5 \pm 0.1^{\circ}\text{C}$. Cross-sectional area of cylinders: 5.56 cm^2 .
Time of contact of ice surfaces: 60 min.

(a) Wt on cylinders: 117.9 g. Placed together after 15 min. Rel. humidity near 0%.

<u>Test no.</u>	<u>Total (kg)</u>	<u>Force of rupture</u> <u>(kg/cm²)*</u>
1	5.4	1.0
2	0	0
3	3.0	0.54
4	2.8	0.50
5	16.5	3.0
6	<u>7.2</u>	<u>1.25</u>
Mean	5.8	Mean 1.04

(b) Wt on cylinders: 1250 g. Placed together after 15 min. Rel. humidity near 0%.

1	10.3	1.85
2	2.0	0.36
3	28.6	5.14
4	12.1	2.18
5	14.5	2.6
6	<u>15.9</u>	<u>7.86</u>
Mean	13.9	Mean 2.50

(c) Wt on cylinders: 1250 g. Placed together after 15 min. Rel. humidity 100%.

1	3.1	0.56
2	18.0	3.23
3	7.2	1.29
4	5.5	0.99
5	19.3	3.47
6	<u>11.1</u>	<u>1.99</u>
Mean	10.7	Mean 1.92

(d) Wt on cylinders: 2252 g. Placed together after 15 min. Rel. humidity 0%.

1	9.4	1.7
2	13.4	2.4
3	<u>22.5</u>	<u>4.05</u>
Mean	15.1	Mean 2.7

(e) Wt on cylinders: 2252 g. Placed together immediately. Rel. humidity 100%.

1	15.8	2.84
2	15.5	2.79
3	27.3	4.91
4	24.9	4.48
5	<u>15.3</u>	<u>2.75</u>
Mean	19.8	Mean 3.55

* Based on cross-sectional area of cylinders.

Discussion

The results show that only a small part of the available surface area is bonded, increasing with the load by which the cylinders are pressed together. This indicates that the surfaces were not flat enough. Inspection of the surfaces after breakage indicates that they had a curvature. Thus, it does not seem possible to obtain a sufficiently flat surface by hand polishing. The microtomed surfaces seem to be flatter than the polished ones. Apparently, a much more elaborate polishing apparatus is needed.

A simple calculation shows that the present experiments could be explained reasonably by the theory of pressure melting. This does not mean that this explanation is necessarily the correct one. A proper conclusion can be reached only by obtaining really flat surfaces.

The melting point of ice is depressed by about 0.0075C/atm . It was found experimentally, for instance, that for ice cylinders pressed together at -0.5C by a force of 2.25 kg , the mean force of separation was 2.3 kg/cm^2 . The average bulk strength of ice is about 15 kg/cm^2 . Hence, only 0.15 cm^2 of each available cm^2 was actually bonded. For pressure melting to take place at -0.5C , a pressure of $0.5/0.0075 = 67\text{ atm} \cong 67\text{ kg/cm}^2$ is needed. Hence the maximum contact area for melting to take place at all must be $2.25/(5.56 \times 67) = 6.1 \times 10^{-3}\text{ cm}^2$ where 5.56 is the cross-sectional area of the cylinders.

If a water layer of at least 10^{-6} cm depth is assumed to be required for freezing to take place, a volume of water of $0.15 \times 10^{-6} = 1.5 \times 10^{-7}\text{ cm}^3$ has to be available. Hence, the thickness of the layer to be melted (assuming no plastic flow takes place) is

$$\frac{1.5 \times 10^{-7}}{6.1 \times 10^{-3}} = 1.64 \times 10^{-5}\text{ cm}.$$

If plastic flow takes place, the initial contact area will have to be smaller and the melted layer must be thicker. The above example indicates that the pressure theory gives reasonable magnitudes. However, the liquidlike layer on ice still plays an important role in these experiments. This can only be demonstrated convincingly if really flat ice surfaces can be obtained. It is likely that automatic polishing will lead to more satisfactory surfaces. An added difficulty lies in the easy contamination of the surfaces involved. The difference in bonding strength for the cylinders which are placed together immediately and those which were bonded after a time interval of 15 min is due to some frosting which takes place on standing. This makes the bonding surfaces rougher so that the contact areas become smaller. Frosting is also more apt to take place at high relative humidity.

A very simplified theory of bonding ice surfaces, which contain appreciable irregularities, has been formulated and is presented in an Appendix. The calculations are based on the assumption of a distribution of small ice cylinders of equal cross sections but different heights located on a non-deformable plate. The cylinders are deformed by a constant force, which is applied by another completely non-deformable flat plate. The deformation as a function of force and time and the force of separation as a function of the load are derived assuming that the distribution of heights is given by a box distribution (i. e., frequency of heights is constant). This theory is only appreciable if the deformation of the cylinders is not too great, as the effect of mutual lateral hindrance of expansion of the cylinders is not considered. Numerical evaluation shows that for constant times, the deformation and bonded areas increase less than linearly with time and load (Fig. A1-3).

REFERENCES

- Faraday, M. (1859) On regelation... Philosophical Magazine, 4th Ser., vol. 17, p. 162.
- ____ (1860) Note on regelation, Proceedings of the Royal Society (London), vol. 10, p. 440.
- Hosler, C. L.; Jensen, D. C.; and Goldshlak, L. (1957) On the aggregation of ice crystals to form snow, Journal of Meteorology, vol. 14, p. 415-420.
- Jellinek, H. H. G. (1957a) Adhesive properties of ice, U. S. Army Snow Ice and Permafrost Research Establishment, Corps of Engineers, Research Report 38; also Journal of Colloid Science, June 1959.
- ____ (1957b) Tensile strength properties of ice adhering to stainless steel, U. S. Army Snow Ice and Permafrost Research Establishment, Corps of Engineers, Research Report 23; also Proceedings of the Physical Society, vol. 71, p. 797-814, 1958.
- Nakaya, U. and Matsumoto, A. (1953) Evidence of the existence of a liquidlike film on ice surfaces, U. S. Army Snow Ice and Permafrost Research Establishment, Corps of Engineers, Research Paper 4.
- Thomson, J. (1859) On recent theories and experiments regarding ice at or near its melting point, Proc. Royal Society (London), Ser. A, vol. 10, p. 152.
- ____ (1861) Notes on Professor Faraday's recent experiments on regelation, Proc. Royal Society (London), Ser. A, vol. 11, p. 198.
- Weyl, W. A. (1951) Surface structures of water and some of its physical and chemical manifestations, Journal of Colloid Science, vol. 6, p. 389.

APPENDIX: COMPRESSION OF AN ASSEMBLY OF CYLINDERS

Assumptions

(a) An assembly of cylinders of equal cross section and a distribution of heights is assumed. The cylinders are compressed by a constant force F between two non-deformable horizontal plates, the lower plate being at rest. The cylinders are assumed to have Poisson's ratio 0.5 (material is incompressible).

(b) The natural strain rate is assumed to be given by,

$$\frac{d\Delta h_t}{(h_i - \Delta h_t) dt} = k \sinh \frac{\sigma_t}{\sigma_0} \quad (1)$$

where Δh_t is the distance the upper plate has advanced at time t , h_i is the initial height of the tallest cylinders, and σ_t the compressive stress at time t ; k and σ_0 are constants.

(c) The force of rupture S after a given time of compression is given by,

$$S = KA_t \quad (1a)$$

where A_t is the total cross-sectional area bonded to the upper plate after compression for a time interval t .

Derivation

The compressive stress can be expressed by,

$$\sigma_t = F/A_t \quad (2)$$

where F is the total constant compressive force and A_t the total cross-sectional area at time t upon which the force acts at that moment.

This cross-sectional area is given by,

$$A_t = \int_{N_{h_i} - \Delta h_t}^{N_{h_i}} A_{t_1} h_x dN + A_{t_1} h_i N_{h_i} \quad (3)$$

where $A_{t_1} h_x$ is the cross-sectional area at time t of one cylinder of original height h_x and dN is the number of cylinders in the interval between h_x and $h_x + dh_x$.

Further (see diagram)

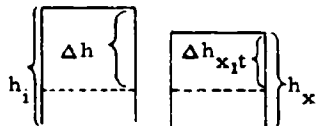

$$h_i - \Delta h_t = h_x - \Delta h_{x,t}$$

Therefore,

$$A_{t_1} h_x (h_x - \Delta h_{x,t}) = A_0 h_x = V_x \quad (4)$$

A2

where A_0 is the original cross section of the cylinders and V_x the volume of one cylinder of original height h_x .

Introducing eq 4 into eq 3 gives,

$$A_t = \frac{A_0 h_i}{h_i - \Delta h_t} N_{h_i} + \int_{N_{h_x - \Delta h_t}}^{N_{h_i}} \frac{A_0 h_x}{h_x - \Delta h_t} dN. \quad (5)$$

The distribution of heights is given by,

$$\frac{dN}{dh_x} = f(h_x). \quad (6)$$

(This distribution does not contain the tallest cylinders of height h_i .)

Introduction of eq 6 into eq 5 gives,

$$A_t = \frac{A_0 h_i}{h_i - \Delta h_t} N_{h_i} + \int_{h_i - \Delta h_t}^{h_i} \frac{A_0 h_x}{h_i - \Delta h_t} f(h_x) dh_x. \quad (7)$$

A simple distribution will be assumed now,

$$\frac{dN}{dh_x} = f(h_x) = \text{constant} = C. \quad (8)$$

Hence,

$$A_t = \frac{A_0 h_i}{h_i - \Delta h_t} N_{h_i} + \frac{CA_0}{h_i - \Delta h_t} \int_{h_i - \Delta h_t}^{h_i} h_x dh_x.$$

Integration yields,

$$A_t = \frac{A_0 h_i}{h_i - \Delta h_t} N_{h_i} + \frac{CA_0}{2(h_i - \Delta h_t)} [h_i^2 - (h_i - \Delta h_t)^2]. \quad (9)$$

Eq 9 can now be introduced into eq 1 making use also of eq 2,

$$-\frac{d(h_i - \Delta h_t)}{(h_i - \Delta h_t) dt} = k \sinh \frac{F}{\sigma_0} \left\{ \frac{1}{\frac{A_0 h_i}{h_i - \Delta h_t} N_{h_i} + \frac{CA_0 [h_i^2 - (h_i - \Delta h_t)^2]}{2(h_i - \Delta h_t)}} \right\}. \quad (10)$$

If $\frac{\sigma_t}{\sigma_0}$ is small, $\sinh \frac{\sigma_t}{\sigma_0} \approx \frac{\sigma_t}{\sigma_0}$, hence eq 10 reduces to

$$-\frac{d(h_i - \Delta h_t)}{dt} = \frac{k'F}{A_0} \frac{2(h_i - \Delta h_t)^2}{2h_i N_{h_i} + C[h_i^2 - h_i - \Delta h_t]^2} \quad (11)$$

Eq 11 can be integrated,

$$-\left(h_i N_{h_i} + \frac{Ch_i}{2}\right) \int_{h_i}^{\Delta h_t} \frac{d(h_i - \Delta h_t)}{(h_i - \Delta h_t)^2} + \frac{C}{2} \int_{h_i}^{h_i - \Delta h_t} d(h_i - \Delta h_t) = \frac{k'F}{A_0} t.$$

Further,

$$\frac{h_i N_{h_i}}{h_i - \Delta h_t} - N_{h_i} + \frac{Ch_i^2}{2(h_i - \Delta h_t)} - \frac{Ch_i}{2} - \frac{C\Delta h_t}{2} = \frac{k'F}{A_0} t.$$

This reduces to

$$\frac{\Delta h_t}{(h_i - \Delta h_t)} = \frac{2k'Ft}{A_0(2N_{h_i} + C)} \quad (12)$$

The force \underline{S} of rupturing the assembly will be assumed to be given by eq 1a. For a given time \underline{t} , the value of Δh_t can be obtained and from it also \underline{A}_t .

Figure A1 shows the deformation Δh_t plotted as a function of time for different loads \underline{F} . Figure A2 shows this deformation as a function of load \underline{F} at constant times

$$\left(\frac{2k'}{A_0(2N_{h_i} + C)}\right) = 1, \quad h_i = 10^{-3}.$$

Figure A3 gives

$$f(A_t) = \frac{h_i^2 - (h_i - \Delta h_t)^2}{2(h_i - \Delta h_t)}$$

from eq 9 as a function of load \underline{F} for constant times. N_{h_i} is a very small number, hence $f(A_t)$ is directly proportional to the bonding strength \underline{S} .

A4

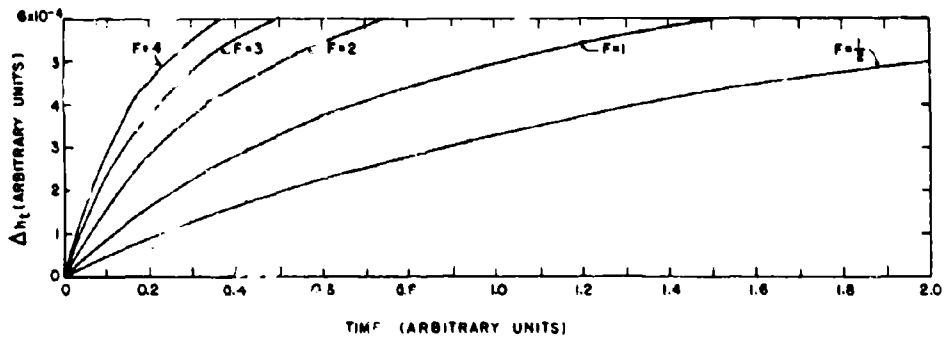

Figure A1. Deformation vs time. Δh_t = distance the upper plate has traveled.

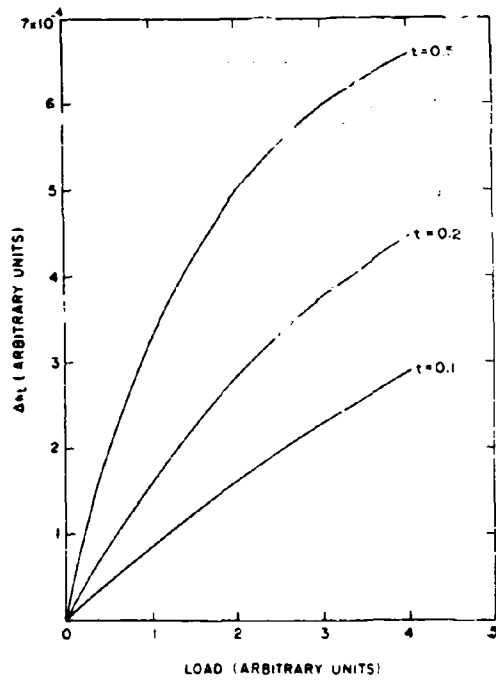

Figure A2. Deformation vs load.

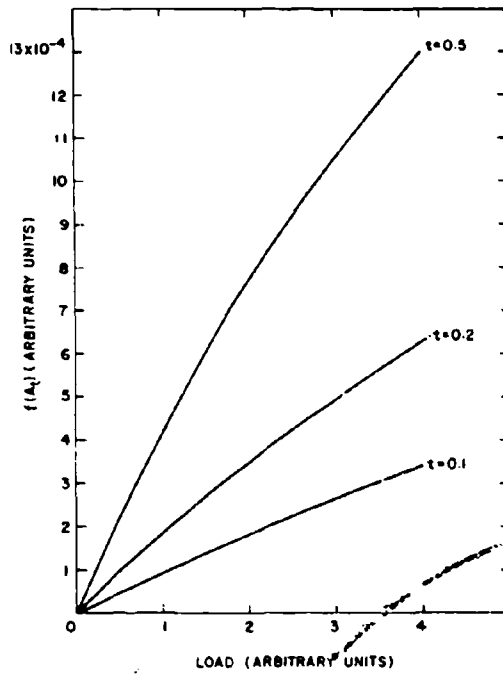

Figure A3. Force of rupture vs load.
 ΔA_t = total cross-sectional area bonded to the upper plate after compression for a time interval t .