

AD 696460

June 1963

Research Memorandum 4

SCALE-MODEL MEASUREMENTS ON A SLOPING-WIRE ANTENNA

by
T. S. Cory



Contract DA-36-039-AMC-00040(E)
Order No. 5384-PM-63-91(6109)
PR&C No. 63-ELNR-6109
Sponsored by ARPA
Order No. 371

SHI Project 4240-5

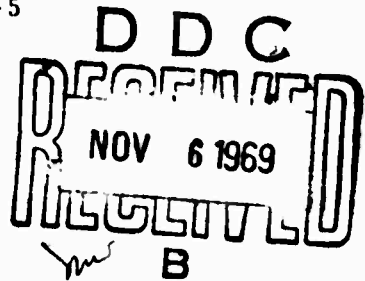

Prepared for

United States Army Electronics Research and Development Laboratory
Fort Monmouth, New Jersey

STANFORD RESEARCH INSTITUTE
MENLO PARK, CALIFORNIA

This document has been approved for public
release and sale; its distribution is
unlimited.

Reproduced by the
CLEARINGHOUSE
for Federal Scientific & Technical
Information Springfield Va. 22151

20



**BEST
AVAILABLE COPY**



June 1963

Research Memorandum 4

SCALE-MODEL MEASUREMENTS
ON A SLOPING-WIRE ANTENNA

SRI Project 4240-5

Prepared for:

United States Army Electronics Research and
Development Laboratory
Fort Monmouth, New Jersey

Contract DA-36-039-AMC-00040(E)

Prepared by:

Terry S. Cory
Terry S. Cory, Research Engineer
Communication Laboratory

This document has been approved for public
release and sale; its distribution is
unlimited.

Copy No. 7

CONTENTS

I	INTRODUCTION	1
II	EXPERIMENTAL PROCEDURE	2
III	SUMMARY OF RESULTS	3
	A. Radiation Patterns over a Flat Ground Plane.	3
	B. Radiation Patterns over a 25-Degree Cone	3

ILLUSTRATIONS

Fig. 1	Coordinate System for Antenna Pattern Measurements	4
Fig. 2	1:100-Scale Model of Short End-Fed Wire Antenna in the Presence of a Flat Ground Plane.	4
Fig. 3	1:100-Scale Model of Short End-Fed Wire Antenna in the Presence of a 25-Degree Conical Hill	5
Fig. 4	1:100-Scale Feed-Antenna Configuration	6
Fig. 5(a)	Elevation-Plane Patterns of a Short Sloping Wire (0.076 λ -0.203 λ) Fed Against a Plane Metallic Ground for $\phi = 0^\circ$ and Slope Angle = 30°	7
Fig. 5(b)	Elevation Plane Patterns of a Short Sloping Wire (0.076 λ -0.203 λ) Fed Against a Plane Metallic Ground for $\phi = 90^\circ$ and Slope Angle = 30°	8
Fig. 5(c)	Elevation Plane Patterns of a Short Sloping Wire (0.076 λ -0.203 λ) Fed Against a Plane Metallic Ground for $\phi = 0^\circ$ and Slope Angle = 40°	9
Fig. 5(d)	Elevation Plane Patterns of a Short Sloping Wire (0.076 λ -0.203 λ) Fed Against a Plane Metallic Ground for $\phi = 90^\circ$ and Slope Angle = 40°	10
Fig. 6(a)	Elevation Plane Patterns of a Short Sloping Wire (0.076 λ -0.203 λ) Fed Against a Conical Metallic Ground for $\phi = 0^\circ$ Slope Angle = 35° , Cone Angle from Horizon = 25°	11
Fig. 6(b)	Elevation Plane Patterns of a Short Sloping Wire (0.076 λ -0.203 λ) Fed Against a Conical Metallic Ground for $\phi = 90^\circ$ Slope Angle = 35° , Cone Angle from Horizon = 25°	12
Fig. 6(c)	Elevation Plane Patterns of a Short Sloping Wire (0.076 λ -0.203 λ) Fed Against a Conical Metallic Ground for $\phi = 90^\circ$ Slope Angle = 45° , Cone Angle from Horizon = 25°	13
Fig. 6(d)	Elevation Plane Patterns of a Short Sloping Wire (0.076 λ -0.203 λ) Fed Against a Conical Metallic Ground for $\phi = 0^\circ$ Slope Angle = 45° , Cone Angle from Horizon = 25°	14

I INTRODUCTION

Radiation patterns of a 1:100-scale model of an end-fed sloping-wire antenna have been measured. The model antenna was made to simulate a tactical HF (3-to-8-Mc) communication antenna used with the AN/TRC-77 radio set. Such an antenna is of particular interest for tactical jungle communications where near-vertical propagation is pertinent rather than ground-wave.

The actual antenna, in addition to the sloping radiator, comes with two 50-foot counterpoise radials separated by 90 degrees on the ground. Since the model was measured in the presence of metal ground surfaces, the effect of the counterpoise on the radiation patterns is not shown. Because the radiator itself is electrically short ($0.076-0.203 \lambda$), the counterpoise is expected to improve the radiation efficiency and to have a minimal effect on the radiation patterns.

On a scale-model basis, it is difficult to be more precise about the patterns than is indicated in this report, because of the difficulty in scaling ground constants. It is possible to measure the free-space patterns of a symmetric sloping-wire structure in free space and reflect this mathematically into a ground geometry that may be controlled. This latter approach is currently being investigated, along with an experimental program to determine the location of effective ground with respect to the earth's surface. As near-vertical radiation is of primary interest, the geometrical optics approach of ground reflection is expected to yield useful answers. Near grazing for vertical polarization, the geometrical optics technique breaks down, and the reflection must be considered as a diffraction problem.

The geometry of the antenna pattern measurements is shown in Fig. 1. The sloping-wire-antenna patterns were measured in the presence of a plane metallic reflecting ground, as is shown in Fig. 2 and in the presence of a 25-degree conical hill, as shown in Fig. 3. Elevation-plane patterns were obtained for two orthogonal polarizations. The sloping wire is shown in Fig. 4.

II EXPERIMENTAL PROCEDURE

Three choices of specifications were available for the model antenna:

- 57-foot wire for 3.0 to 3.8 Mc
- 40-foot wire for 3.8 to 5.5 Mc
- 25-foot wire for 5.5 to 8.0 Mc.

Since the results from these wires were expected to be similar, the highest-frequency case was chosen, because a large ground-plane structure could not be used. The scale factor was chosen to be 100:1 for ease of conforming it to the scale-model pattern range facilities.

For each ground-plane configuration, only two wire-slope angles (30 and 40 degrees) were taken, because it is evident that the patterns are slowly varying functions of slope angle.

Some azimuthal patterns were taken in the beginning. It was soon apparent that all pertinent information could be obtained from elevation cuts only. The azimuthal cuts taken are nearly omnidirectional, because they were taken through the apparent beam maximum in the $\phi = 0$ -degree plane, and this corresponded rather closely with the slope of the wire.

At each frequency, the patterns taken are the same scale and the plots are linear field patterns. The transmitter was located at the recording shack, and the energy was transmitted from a feed antenna located above the shack. The signal was received on the model antenna. For the most part, four patterns were measured at each frequency. Two fixed transmitter polarizations were used for each of two elevation cuts at 0 degrees and 90 degrees in azimuth. The measured patterns for the sloping wire over the metallic plane and over the 25-degree metallic cone are shown in Figs. 5 and 6. On all patterns, the transmitted polarizations are denoted by either solid or dotted lines. A solid line for 0 degrees corresponds to vertical polarization and a dotted line corresponds to horizontal polarization for both the 0- and 90-degree cuts. For horizontal polarization, the field vector is parallel to the rotation axis for all rotation angles. For vertical polarization, the field vector is orthogonal to the rotation axis for all rotation angles. The geometry of Fig. 1, shows the field vector parallel to the rotation axis labeled as E_ϕ and the field vector orthogonal to the rotation axis labeled as E_θ .

III SUMMARY OF RESULTS

A. RADIATION PATTERNS OVER A FLAT GROUND PLANE

The change of wire slope angle produces only a small change in the patterns. The vertical-polarization beam maximum through 0 degrees is shown to be lower in angle in the 0-degree direction than in the 180-degree direction. Although the transmitter power was held constant at a given frequency while all four patterns were taken, it is evident that at 90 degrees in elevation the vertically polarized signal in the vertical cut at 0 degrees in azimuth does not agree with the horizontally polarized signal in the vertical cut at 90 degrees in azimuth. This may be due in part to ground screen radiation effects, but will not alter the individual patterns to any great extent. The antenna is not an effective radiator for vertical radiation in this configuration.

B. RADIATION PATTERNS OVER A 25-DEGREE CONE

For this configuration, a change of 10 degrees in wire slope had a nearly negligible effect on the patterns. The elevation beam maximum for the 0-degree vertical cut is again lower in the 0-degree direction. There is more radiation at higher angles than for the flat ground case. For some frequencies, there is a dish focusing effect which gives an appreciable overhead radiation component, but this is a rather narrow band and would be quite unpredictable in the practical full-scale case.

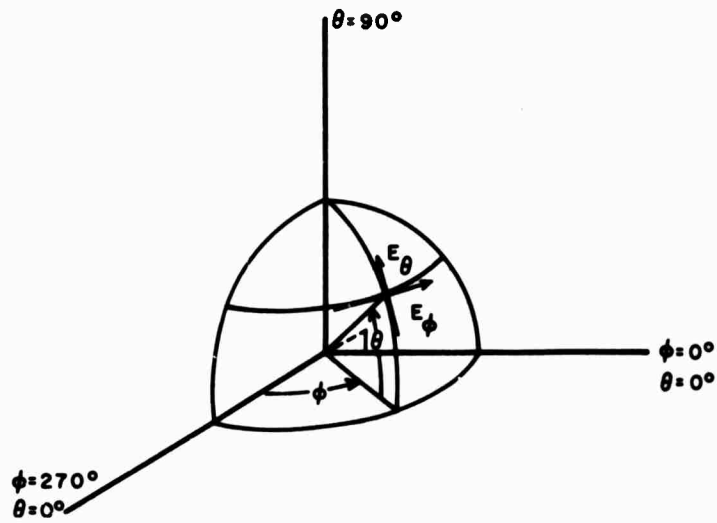

FIG. 1 COORDINATE SYSTEM FOR ANTENNA PATTERN MEASUREMENTS

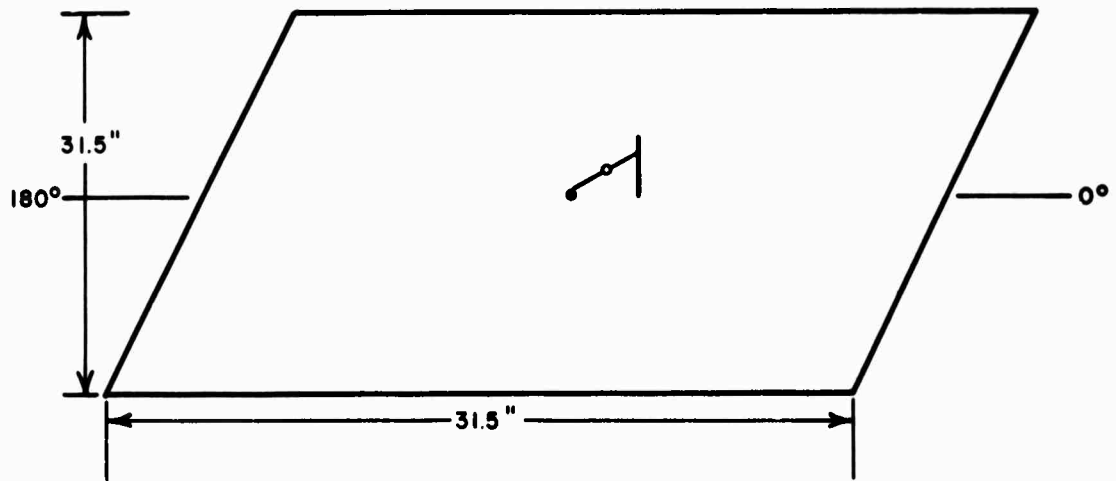

FIG. 2 1:100-SCALE MODEL OF SHORT END-FED WIRE ANTENNA IN THE PRESENCE OF A FLAT GROUND PLANE

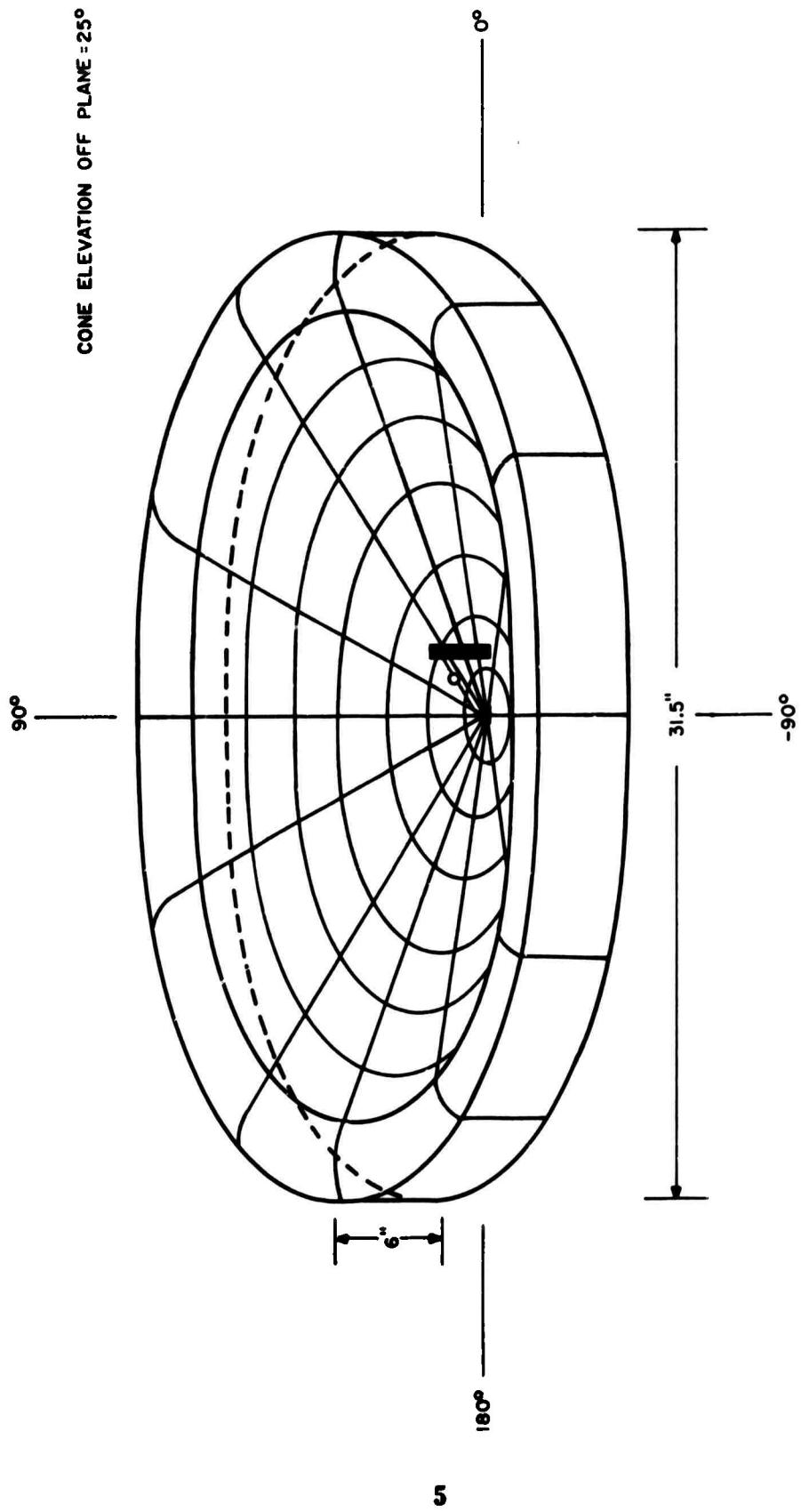

FIG. 3 1:100-SCALE MODEL OF SHORT END-FED WIRE ANTENNA IN THE PRESENCE OF A 25-DEGREE CONICAL HILL

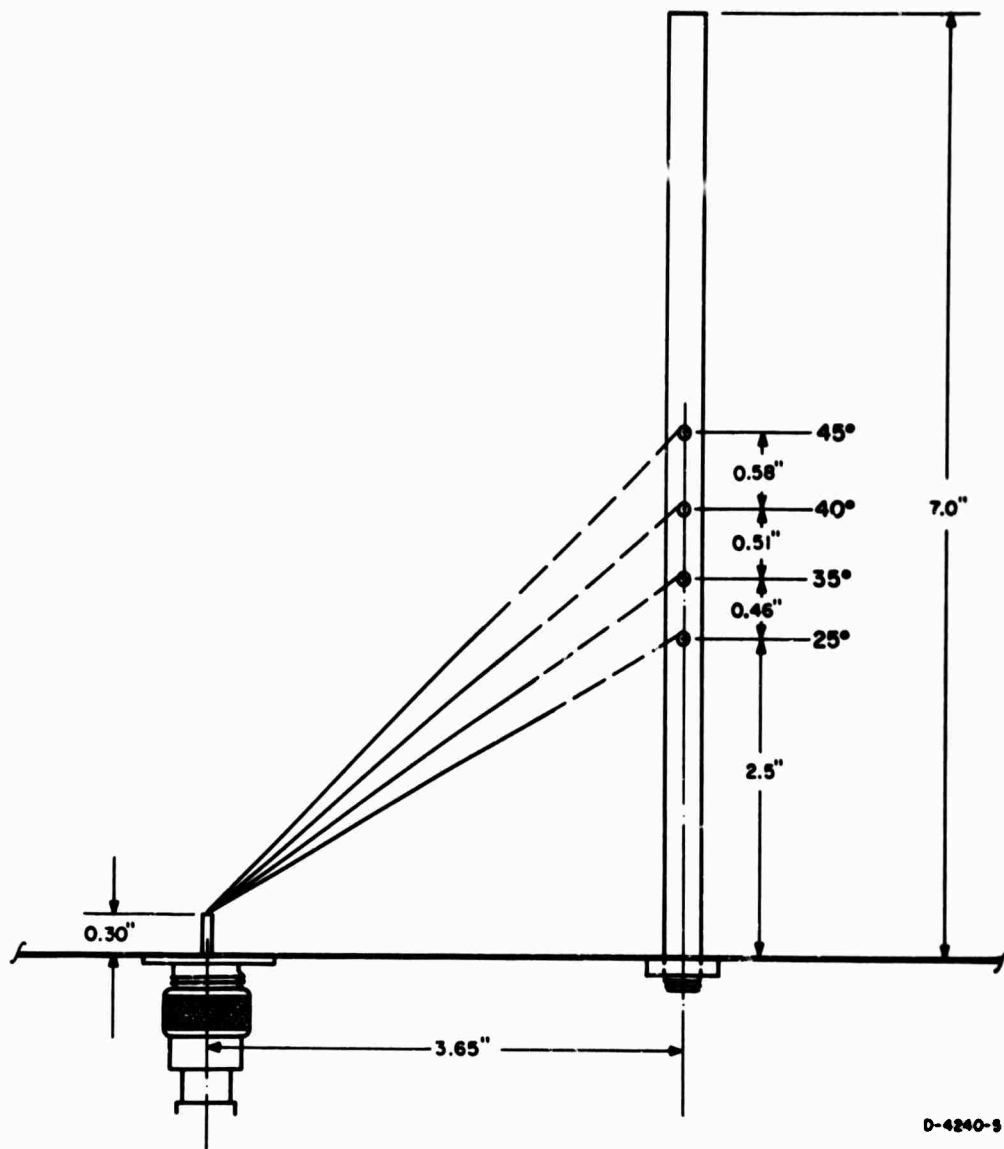

FIG. 4 1:100-SCALE FEED-ANTENNA CONFIGURATION

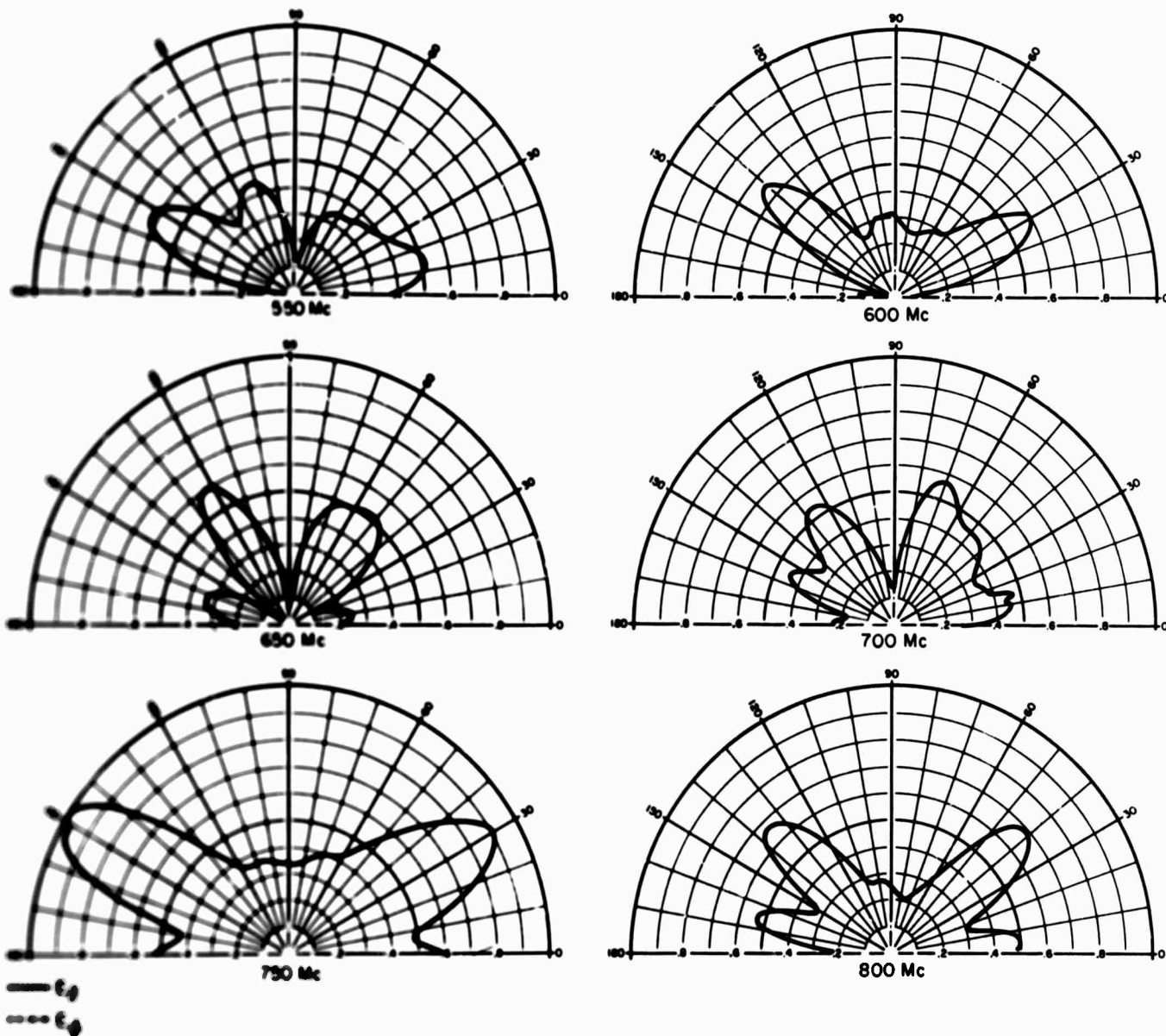
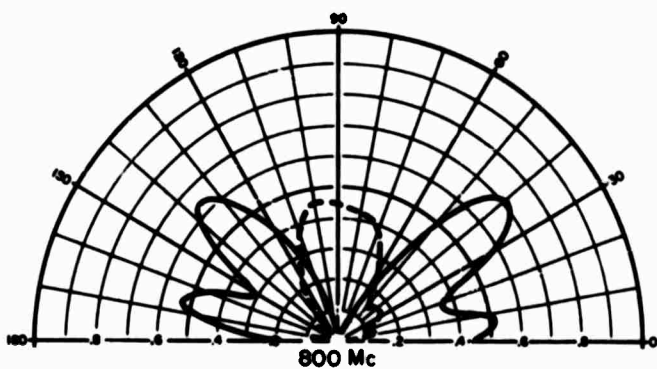
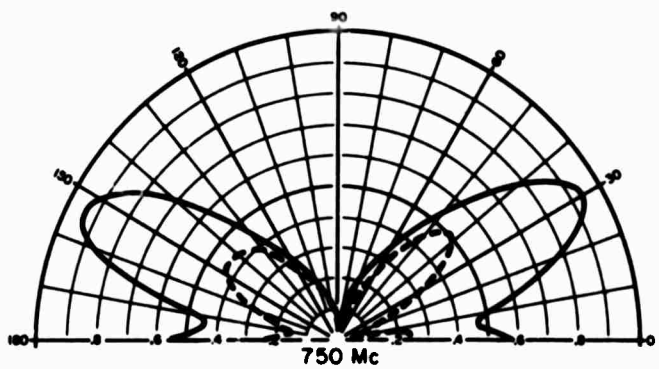
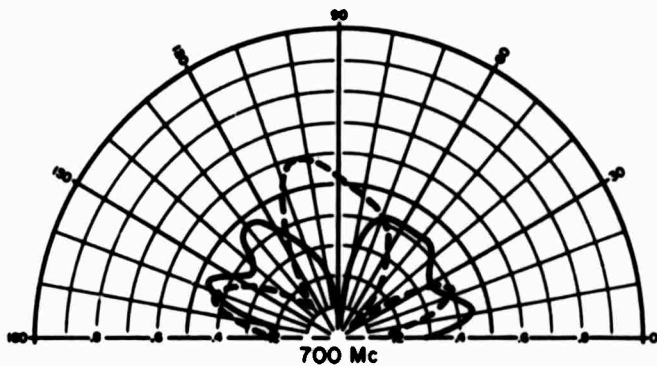
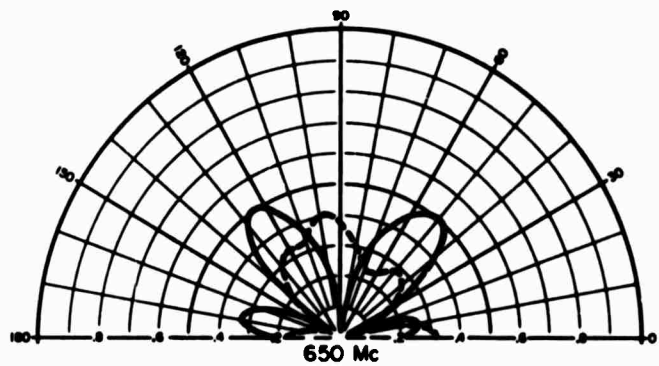
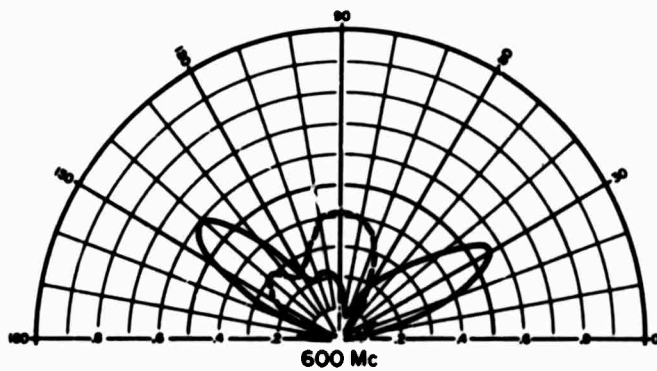
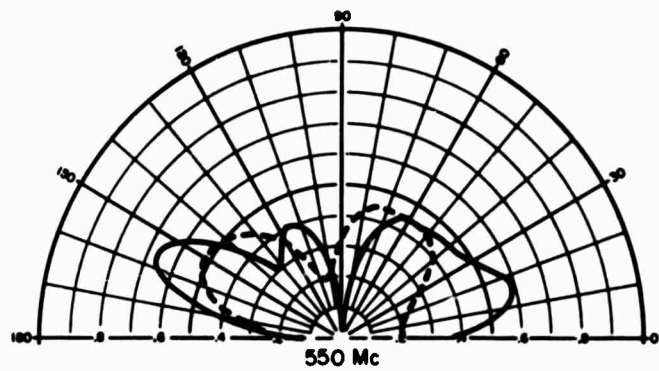

FIG. 5(e) ELEVATION-PLANE PATTERNS OF A SHORT SLOPING WIRE ($0.076\lambda - 0.203\lambda$)
 FED AGAINST A PLANE METALLIC GROUND FOR $\phi = 0^\circ$ AND SLOPE
 ANGLE = 30°

D-4240-14



— E_θ
 - - - E_ϕ

0-4240-21

FIG. 5(b) ELEVATION PLANE PATTERNS OF A SHORT SLOPING WIRE (0.076λ - 0.203λ) FED AGAINST A PLANE METALLIC GROUND FOR $\phi = 90^\circ$ AND SLOPE ANGLE = 30°

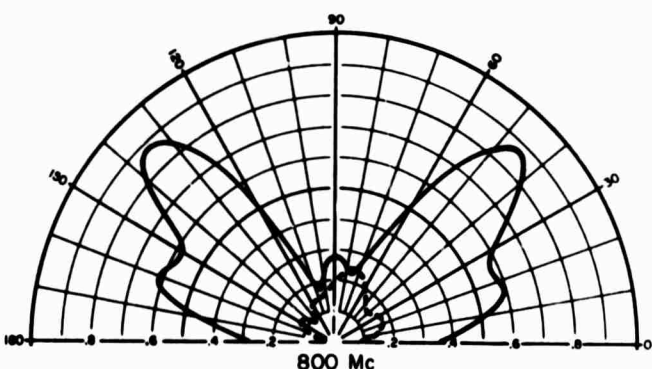
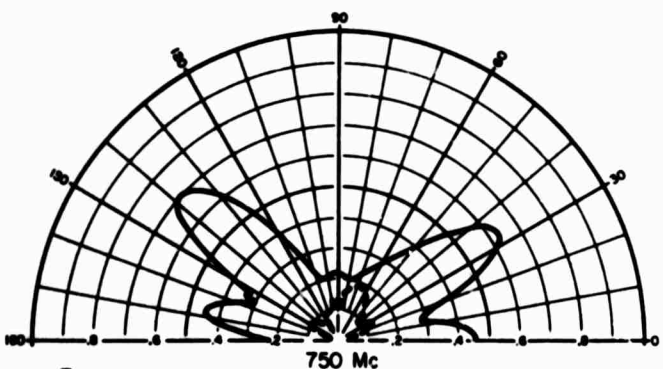
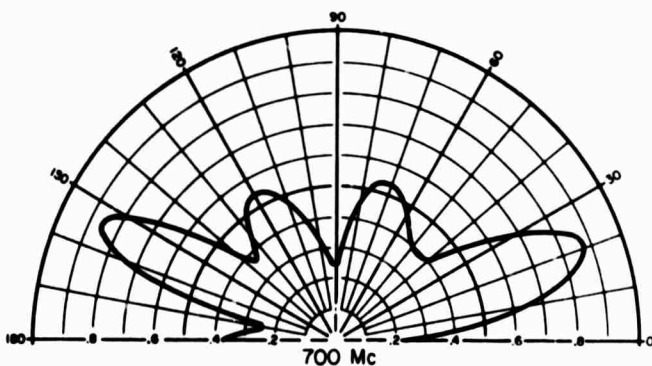
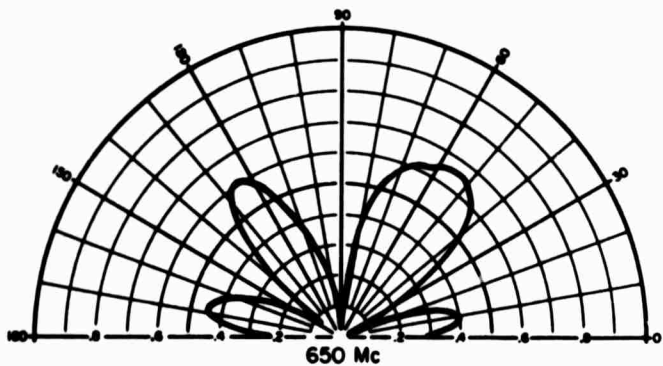
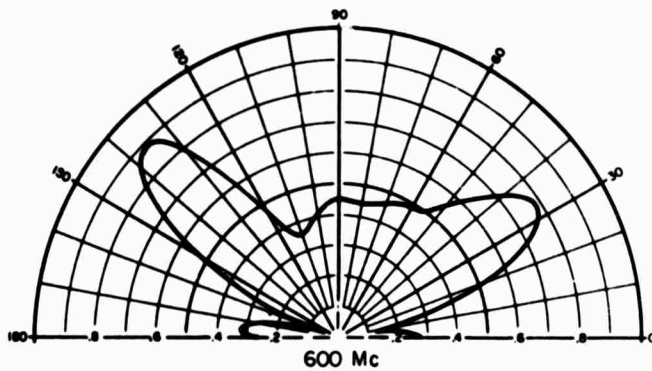
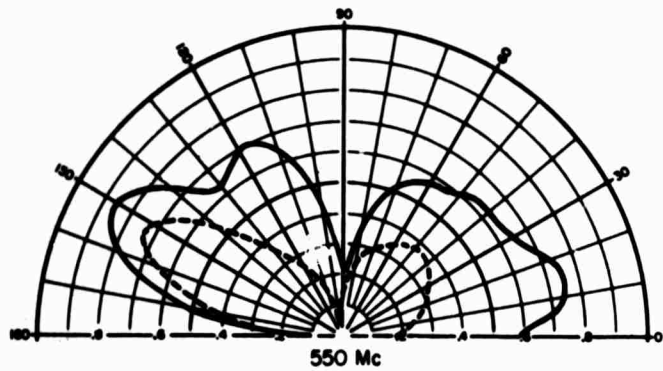

— E_{θ}
 - - - E_{ϕ}

D-4240-15

FIG. 5(c) ELEVATION PLANE PATTERNS OF A SHORT SLOPING WIRE ($0.076\lambda - 0.203\lambda$) FED AGAINST A PLANE METALLIC GROUND FOR $\phi = 0^\circ$ AND SLOPE ANGLE = 40°

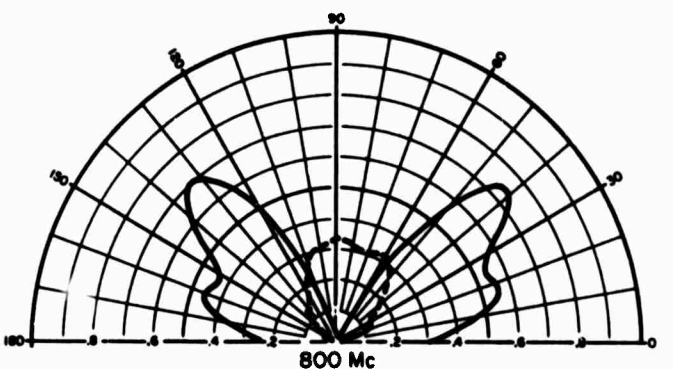
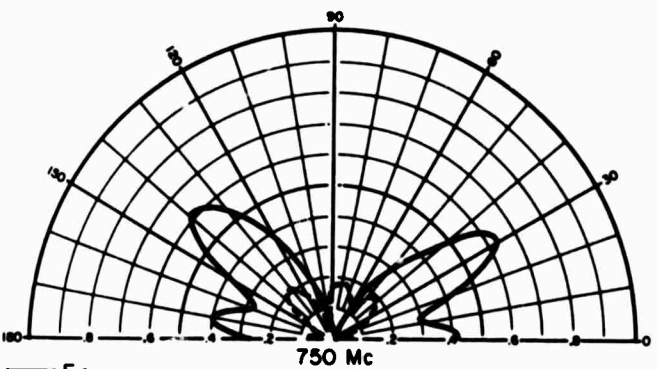
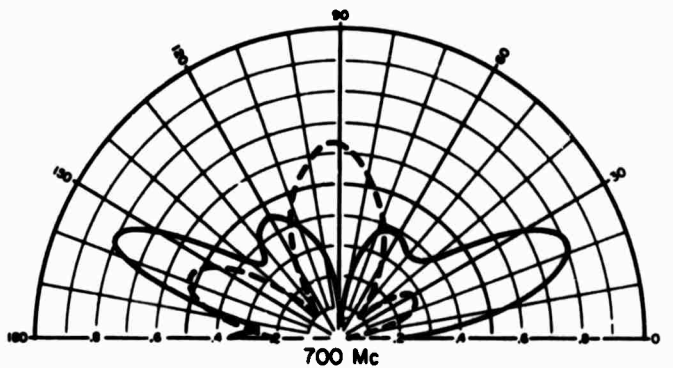
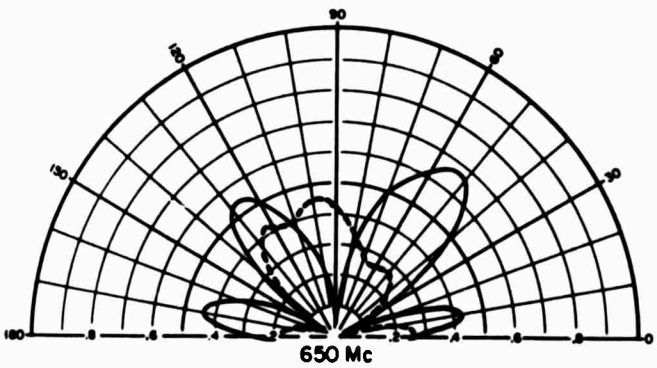
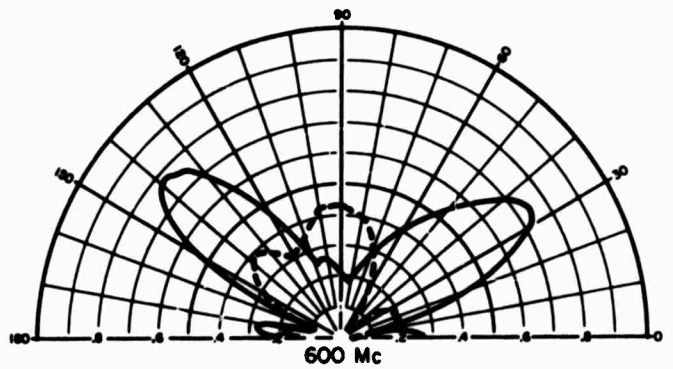
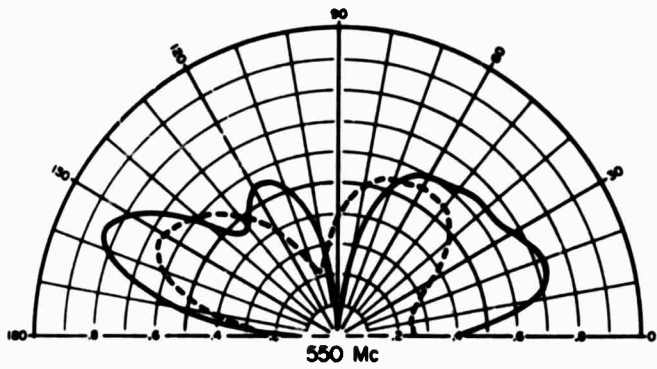

— E_{θ}
 - - - E_{ϕ}

D-4240-16

FIG. 5(d) ELEVATION PLANE PATTERNS OF A SHORT SLOPING WIRE (0.076λ - 0.203λ) FED AGAINST A PLANE METALLIC GROUND FOR $\phi = 90^\circ$ AND SLOPE ANGLE = 40°

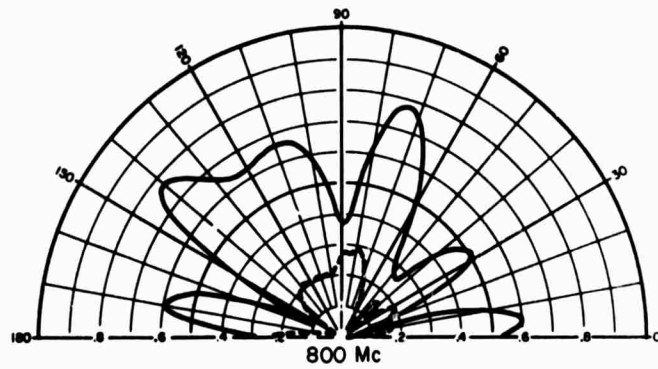
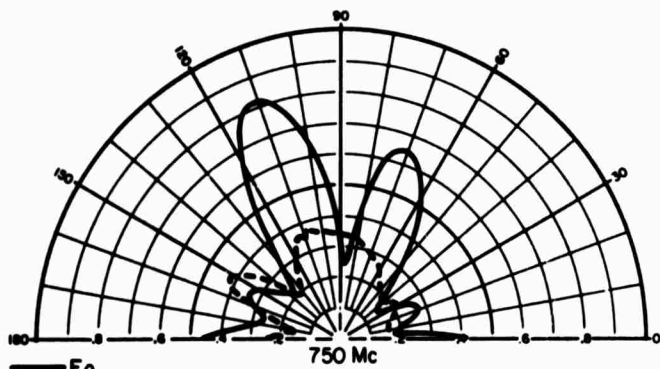
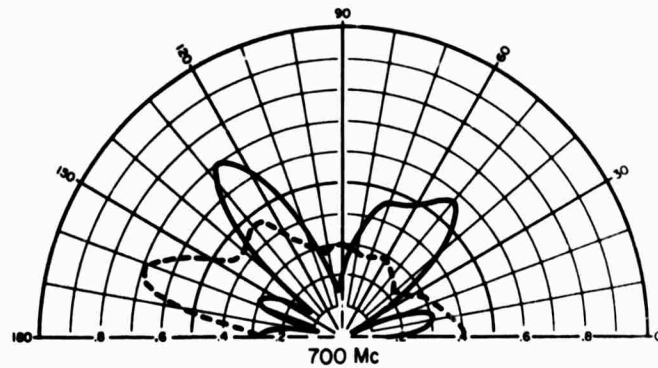
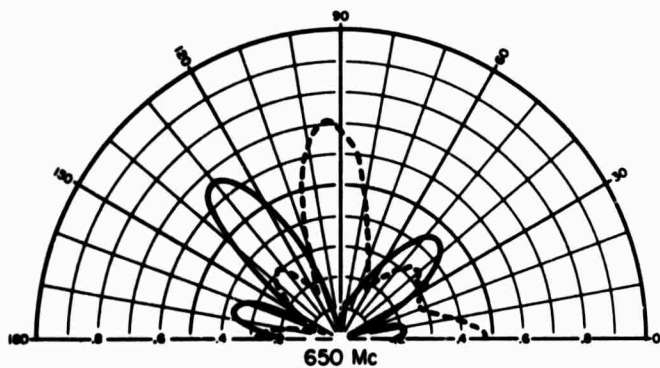
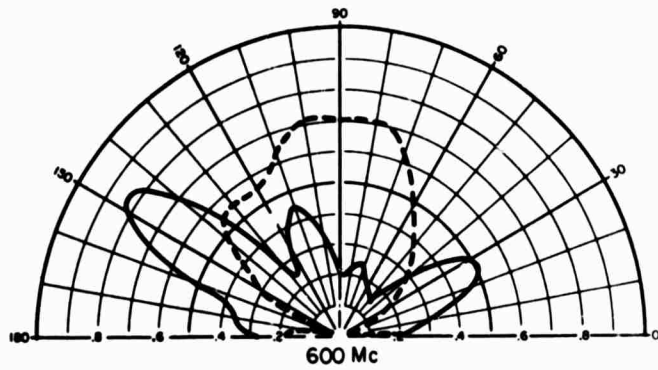
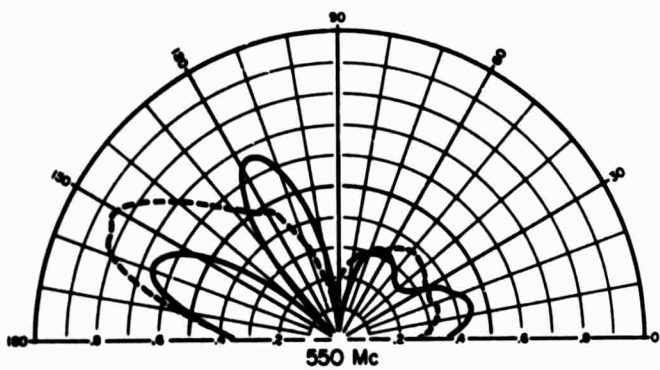

— E_θ
 --- E_ϕ

D-4240-18

FIG. 6(a) ELEVATION PLANE PATTERNS OF A SHORT SLOPING WIRE (0.076λ - 0.203λ) FED AGAINST A CONICAL METALLIC GROUND FOR $\phi = 0^\circ$, SLOPE ANGLE = 35° , CONE ANGLE FROM HORIZON = 25°

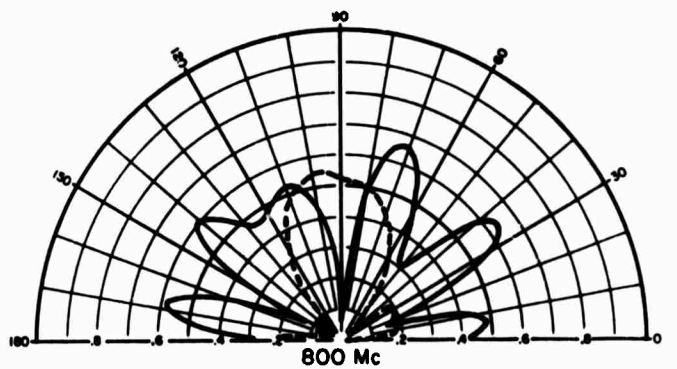
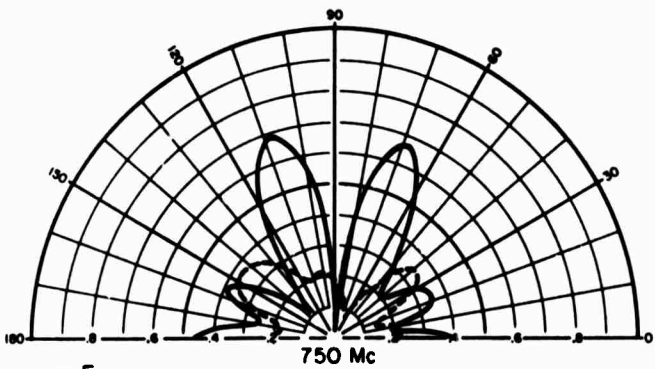
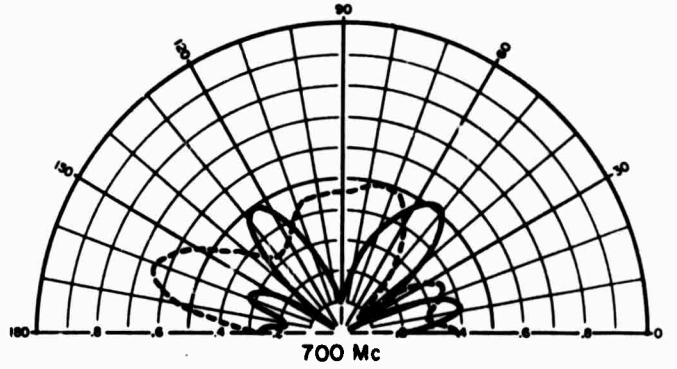
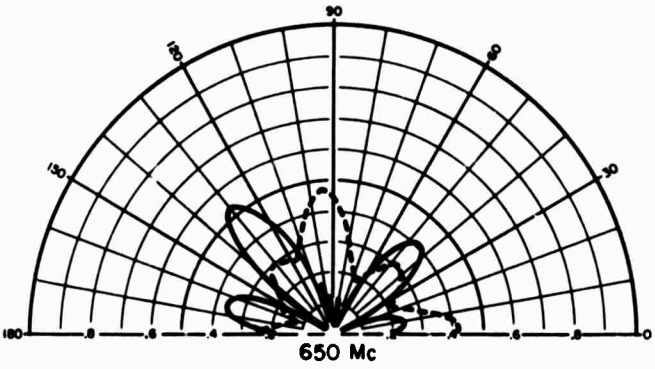
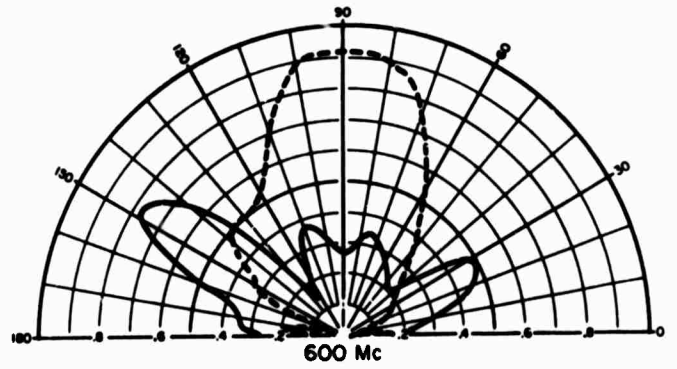
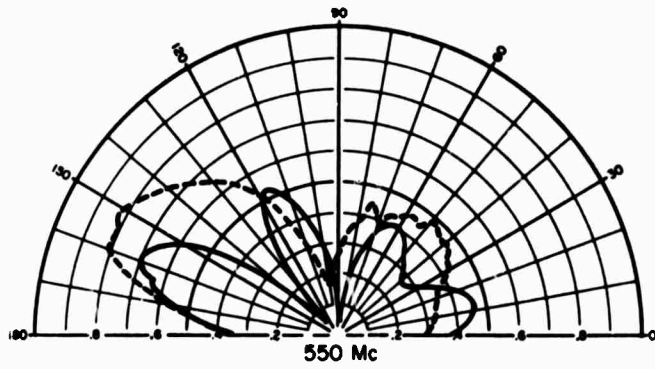

— E_θ
 - - - E_ϕ

D-4240-20

FIG. 6(b) ELEVATION PLANE PATTERNS OF A SHORT SLOPING WIRE (0.076λ - 0.203λ) FED AGAINST A CONICAL METALLIC GROUND FOR $\phi = 90^\circ$, SLOPE ANGLE = 35° , CONE ANGLE FROM HORIZON = 25°

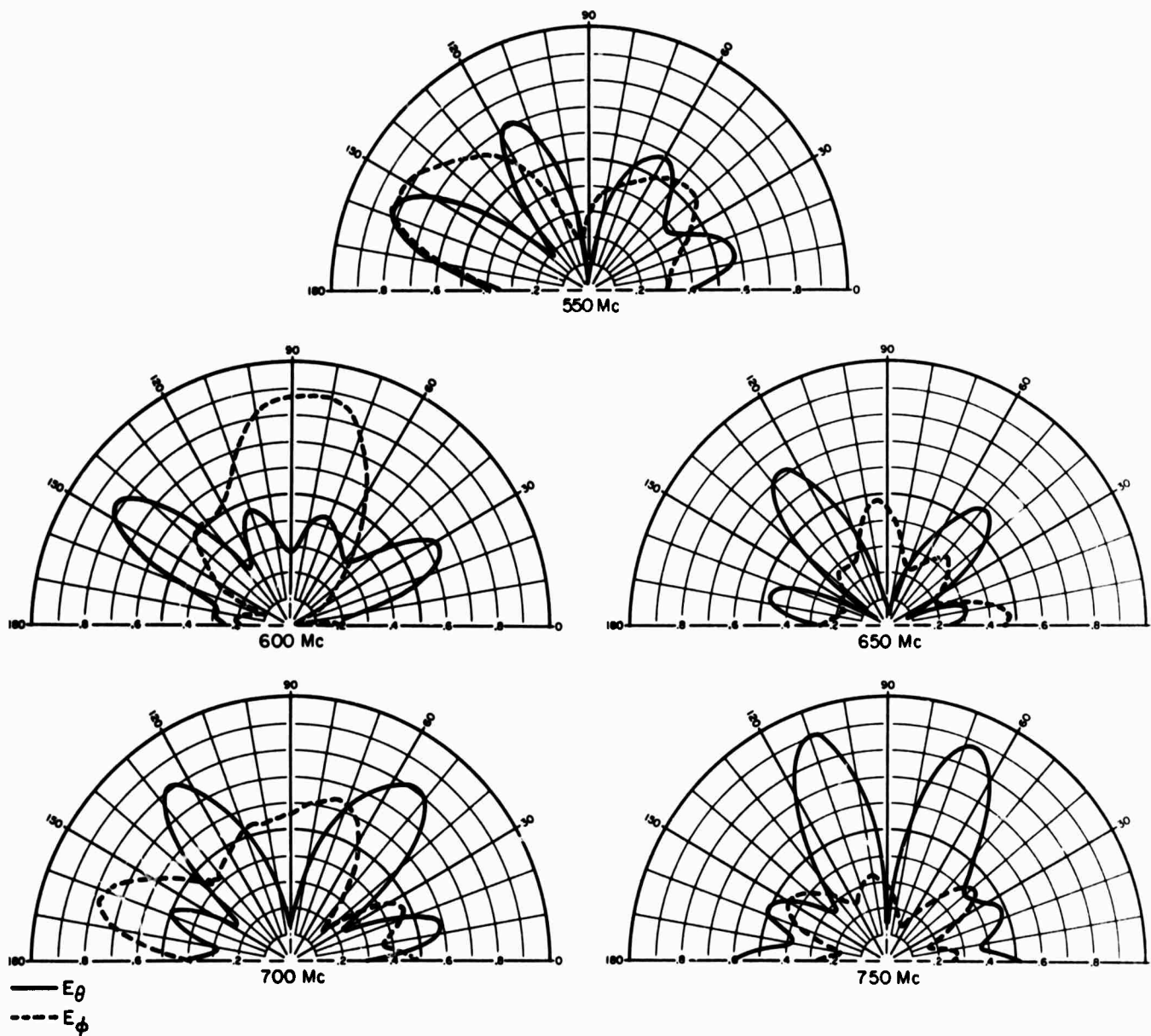

D-4240-19

FIG. 6(c) ELEVATION PLANE PATTERNS OF A SHORT SLOPING WIRE (0.076λ - 0.203λ)
 FED AGAINST A CONICAL METALLIC GROUND FOR $\phi = 90^\circ$, SLOPE
 ANGLE = 45° , CONE ANGLE FROM HORIZON = 25°

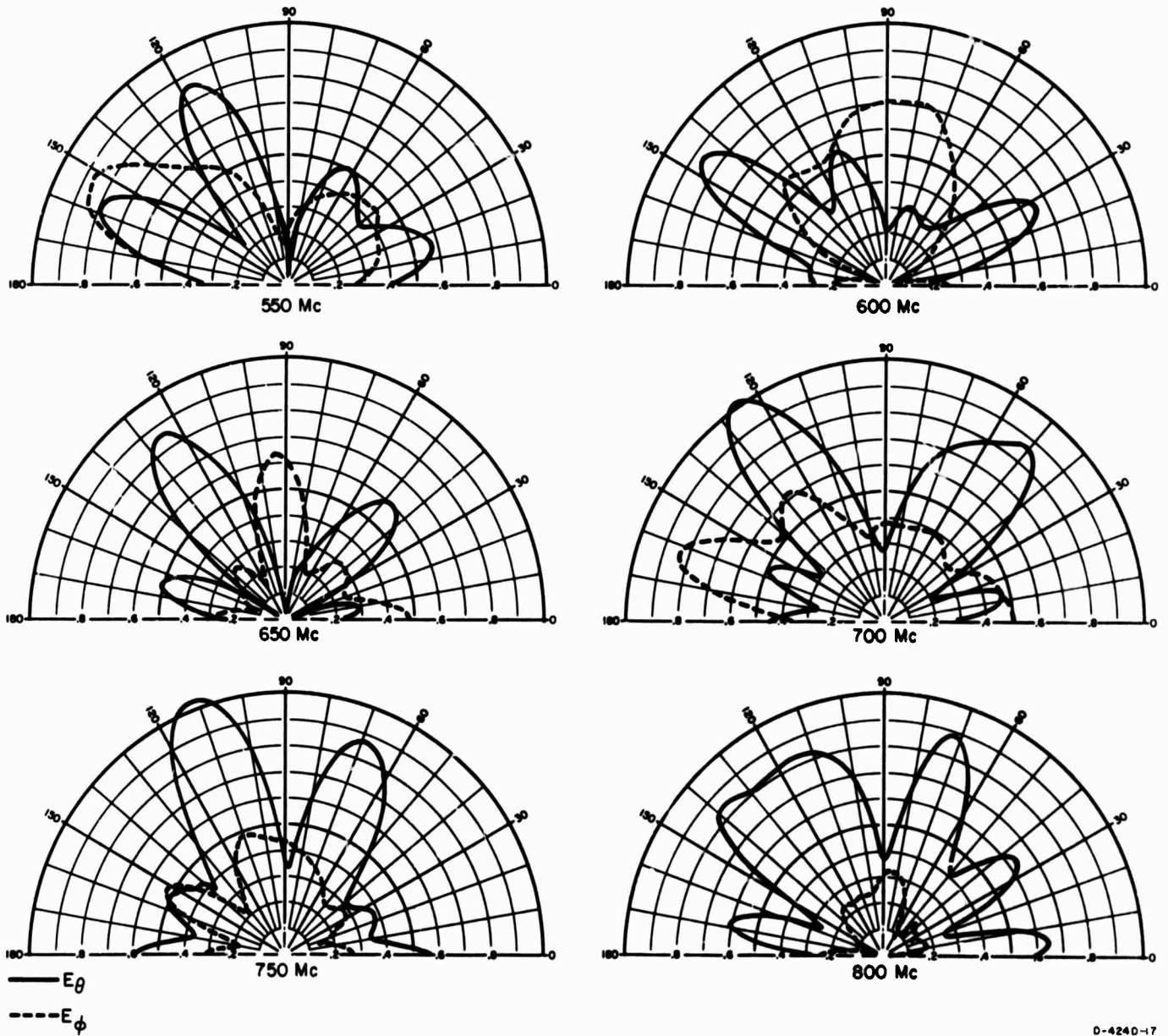

D-4240-17

FIG. 6(d) ELEVATION PLANE PATTERNS OF A SHORT SLOPING WIRE ($0.076\lambda-0.203\lambda$) FED AGAINST A CONICAL METALLIC GROUND FOR $\phi = 0^\circ$, SLOPE ANGLE = 45° , CONE ANGLE FROM HORIZON = 25°

DOCUMENT CONTROL DATA - R & D

(Security classification of title, body of abstract and indexing annotation must be entered when the overall report is classified)

1. ORIGINATING ACTIVITY (Corporate author) Stanford Research Institute Menlo Park, California 94025	2a. REPORT SECURITY CLASSIFICATION Unclassified 2b. GROUP (If applicable) N/A
---	--

3. REPORT TITLE
 Scale-Model Measurements On A Sloping-Wire Antenna

4. DESCRIPTIVE NOTES (Type of report and inclusive dates)
 Research Memorandum 4

5. AUTHOR(S) (First name, middle initial, last name)
 T. S. Cory

6. REPORT DATE June 1963	7a. TOTAL NO. OF PAGES 18	7b. NO. OF REFS 0
-----------------------------	------------------------------	----------------------

8a. CONTRACT OR GRANT NO. 8. PROJECT NO. a. c.	9a. ORIGINATOR'S REPORT NUMBER(S) 9b. OTHER REPORT NO(S) (Any other numbers that may be assigned this report)
---	--

10. DISTRIBUTION STATEMENT
 This document has been approved for public release and sale; its distribution is unlimited.

11. SUPPLEMENTARY NOTES	12. SPONSORING MILITARY ACTIVITY Advanced Research Projects Agency Washington, D. C.
-------------------------	--

13. ABSTRACT
 Radiation patterns of a 1:100-scale model of an end-fed sloping-wire antenna have been measured. The model antenna was made to simulate a tactical HF (3-to-8-Mc) communication antenna used with the AN/TRC-77 radio set. Such an antenna is of particular interest for tactical jungle communications where near-vertical propagation is pertinent rather than ground-wave.

14.

KEY WORDS

LINK A		LINK B		LINK C	
ROLE	WT	ROLE	WT	ROLE	WT

Sloping-Wire Antenna
 Antenna Pattern Measurements
 SEACORE

Radiation pattern of a sloping-wire antenna was measured. The model antenna was used to stimulate a tactical antenna (3-10-6) to determine antenna gain with the ATR-77 radio set. When an antenna is used for tactical purposes, the radiation pattern is of primary interest for tactical purposes. The radiation pattern of a sloping-wire antenna was measured. The model antenna was used to stimulate a tactical antenna (3-10-6) to determine antenna gain with the ATR-77 radio set. When an antenna is used for tactical purposes, the radiation pattern is of primary interest for tactical purposes. The radiation pattern of a sloping-wire antenna was measured. The model antenna was used to stimulate a tactical antenna (3-10-6) to determine antenna gain with the ATR-77 radio set. When an antenna is used for tactical purposes, the radiation pattern is of primary interest for tactical purposes.