

AD 697276

**R 644**

Technical Report

**HOUSING FOR RVN REFUGEES**

October 1969

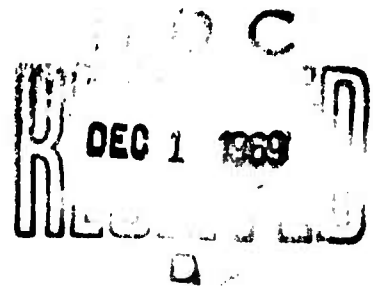

Sponsored by

**NAVAL FACILITIES ENGINEERING CMMAND**



**U. S. NAVAL CIVIL ENGINEERING LABORATORY**

**Port Hueneme, California**

Reproduced by the  
**CLEARINGHOUSE**  
for Federal Scientific & Technical  
Information Springfield Va. 22151

This document has been approved for public  
release and sale; its distribution is unlimited.

## CONTENTS

	page
INTRODUCTION . . . . .	1
PLANNING AND INITIAL WORK . . . . .	4
Site Selection . . . . .	4
Layout and Site Preparation . . . . .	4
Orientation and Protection From Elements . . . . .	5
Space Requirements . . . . .	6
Ventilation . . . . .	7
Building Layout . . . . .	8
FUNCTIONAL ELEMENTS OF BUILDINGS . . . . .	9
Foundations . . . . .	9
Floors . . . . .	10
Frames . . . . .	12
Walls . . . . .	15
Roofs . . . . .	16
MATERIALS . . . . .	19
Earth . . . . .	19
Concrete . . . . .	23
Ordinary Mixes . . . . .	23
Coral Concrete . . . . .	23
Seawater in Concrete . . . . .	23
Watertight Concrete . . . . .	24
Lightweight Concrete . . . . .	24
Concrete Blocks . . . . .	26
Plastics . . . . .	27
CONSTRUCTION OF TYPICAL WOOD FRAME HUTMENT . . . . .	29

	page
USE OF SALVAGE LUMBER IN BUILDING CONSTRUCTIONS . . . . .	33
ROOF AND WALL CLADDING . . . . .	34
Panel Coverings and Claddings . . . . .	34
Steel Sheeting . . . . .	35
Aluminum Sheeting . . . . .	35
Asbestos—Cement Panels . . . . .	35
Plastic Panels . . . . .	36
Plywood Panels . . . . .	36
Wood Boards . . . . .	36
Wet Shingles . . . . .	37
Stucco . . . . .	38
Wood or Composition Shingles . . . . .	38
Fabric or Plastic Sheeting . . . . .	38
Vegetation Covering . . . . .	38
BAMBOO CONSTRUCTION . . . . .	39
TERMITE PROOFING . . . . .	41
BIBLIOGRAPHY . . . . .	42

## INTRODUCTION

This report is intended for the use of U. S. military forces concerned with providing technical advice and supervision to Republic of Vietnam (RVN) refugees engaged in constructing emergency dwellings. The concern in this report is for quickly erected structures that will shelter the refugees for periods of several weeks to months, but some attention is also given to construction that would have a useful lifetime of several years. Depending upon the decisions of local authorities, the housing might be used for transient groups arriving in successive waves or for more settled populations which might stay for indefinite periods.

Some examples of primitive types of construction are shown in this report, and certain innovative material has been included. Even though the problem is primarily one of providing immediate shelter, thought should be given to the qualities of comfort that can be accomplished within the requirements of simplicity. It may be assumed that the housing should be of temporary character, but attention to certain details of construction could result in more permanent structures at little additional cost. The dwellings should be of types which could be constructed by the natives using mutual aid and self-assistance in their folk patterns. The native population has been housing itself for centuries and has acquired a knowledge of very simple building techniques. The self-help principle should be encouraged, and the ingenuity and work abilities of the population should be guided.

In the first hours after villagers have left their homes, there may be need to improvise immediate shelter from the materials at hand. The emergency dwellings may have to be considerably smaller and less comfortable than normal. The ingenuity and industry of the occupants must be relied upon for much of the work but, even at this time, guidance in site selection and settlement layout will be valuable.



Where the need is urgent, temporary shelter may be provided by (1) natural caves or by holes dug into hillsides or embankments; (2) roofed-over trenches or holes where ground conditions are suitable; (3) huts with wood poles as walls and closely laid branches covered with turf for roofs, or (4) tents of light framing and any available covering. Vegetation, soil, timber, or materials retrieved from other construction may be used to improvise emergency cover.

The general form of the refugee settlements will vary with circumstances, including the type of site available and access to conveniences. Random arrangements of single family dwellings might be used, or linear or grid layouts might be preferable. Depending on the availability of materials and the skill of the workers, single family dwellings or multifamily arrangements under a single roof might be constructed.



The structural types could be massive, skeleton, or composite and might be no more than a version of tent structure. The construction would be considered temporary but might be upgraded into more permanent structures.



The dwelling units could be small; approximately 240 square feet of floor space and a 7-foot ceiling would be adequate for a family of four in RVN. A square plan would have advantages, but problems of roof structure might dictate a short-span arrangement.

Indigenous material should be used for the construction of emergency refugee housing to the extent possible. However, advantage should be taken of the availability of imported materials such as corrugated sheeting, plywood, sized lumber, and cement. The best use of cement might be in making stabilized sand or soil building blocks or walls.

## PLANNING AND INITIAL WORK

### Site Selection

The site should be personally inspected rather than selected from maps or from second-hand information. The site should not be subjected to flooding, should be on sound, well-drained soil, and should be situated away from heavy traffic and sources of noise.

### Layout and Site Preparation

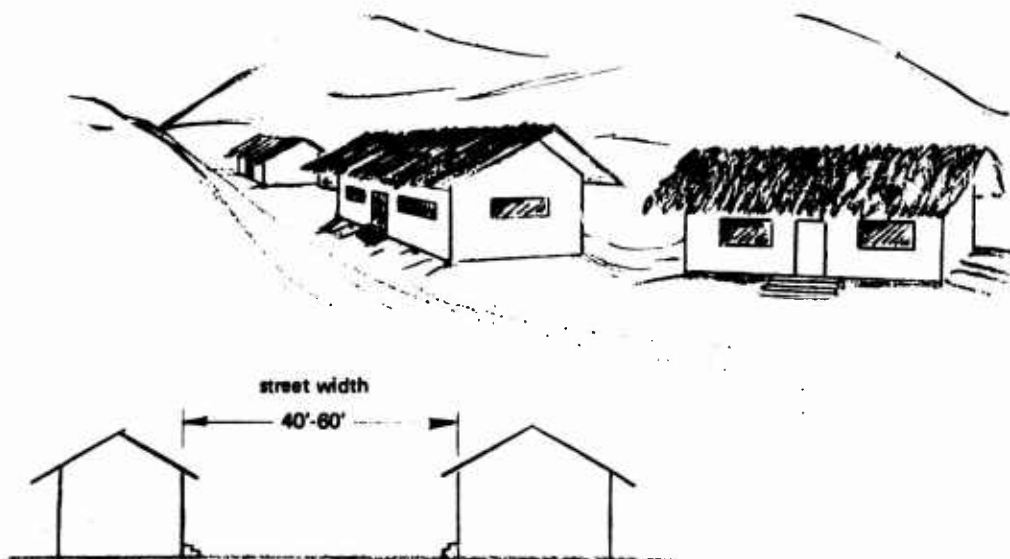

The village site should be laid out to take best advantage of the natural situation. It is best not to build on the crest of hills; side slopes provide better shelter from winds. Roads or streets should preferably be straight but slight curves are acceptable. Street widths should provide 40-to-60 feet between facing dwellings. Streets should not slope steeply; diagonal or curving paths

are best in hilly terrain. The habits of the population should be considered; the most used buildings should be in the center of the settlement. Water supply should be centrally located, as should other communal facilities. Latrines and sewer disposal should be to leeward and should be on lower ground than the other buildings and facilities. Settlements should be built on one side of principal traffic arteries with loop access roads and interior convenience paths provided.

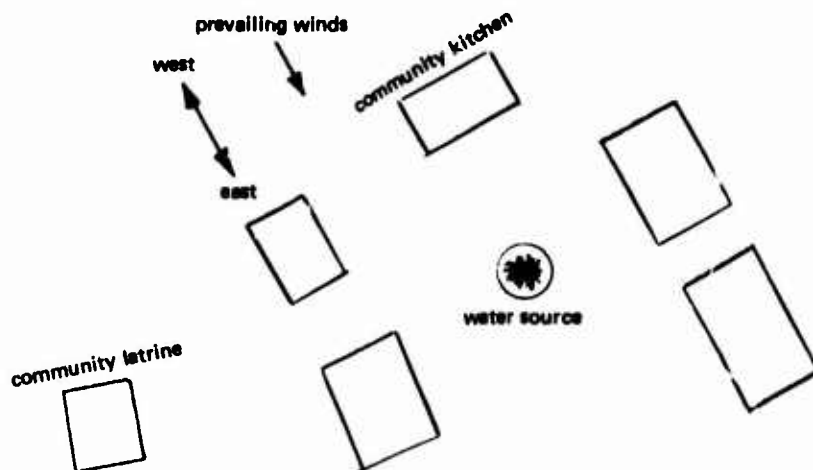

Each separate building site should be level and smooth and should be a few inches above natural grade. The buildings need not all be at the same elevation; however, differences in site height should be minimized so as to prevent problems of privacy or prestige.

#### Orientation and Protection From Elements

The long axes of the buildings should lie as nearly east-west as possible to minimize heat gain by the walls, and to facilitate shading. Protection against overly strong or cool winds should be considered, and the open side of the buildings should be built to leeward.

Direct sunlight through doors and windows should be avoided. If the windows are glazed, the shades should be outside the glass. North- and south-facing openings can be shaded with horizontal canopies. East- and west-facing openings require vertical shades at the sides. West-facing openings should be avoided. East and west facing walls receive most heat from the sun.

### Space Requirements

In refugee housing, a family of four can be accommodated within 240 square feet; 40 square feet of floor is required for each additional person. In the RVN, additional living space can be provided out-of-doors by means of a covered veranda or patio.

Recommended ceiling height for the small-statured Vietnamese refugees is 7 to 7-1/2 feet. Higher ceilings require a greater expenditure of material and labor, require greater amounts of sun shading, and expose more wall area to the heat of the sun.

Circumstances will dictate whether single family buildings or multifamily arrangements under a single roof are most suitable. Single-family dwellings can be partitioned with light screens or curtains; if several families are under a single roof, more substantial partitions are desirable.

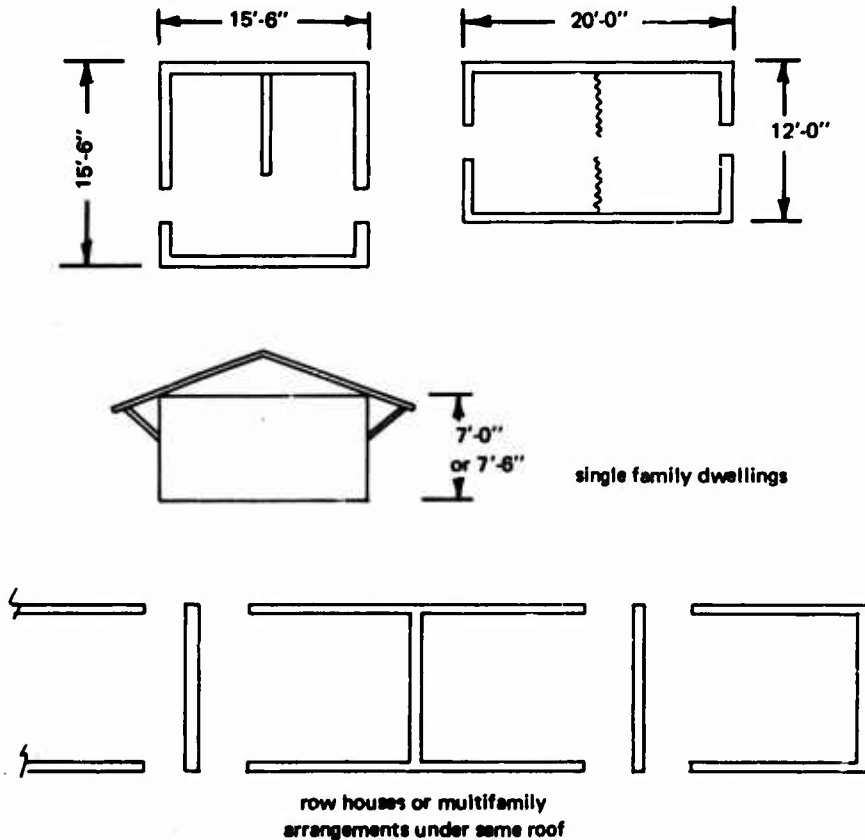

## Ventilation

The traditional equatorial dwelling is a relatively flimsy structure of a very open design. Heat from cooking fires, heat transmitted through the walls and roof or released from storage in them, and heat from the sun through doors and windows increase ventilation requirements. In crowded buildings the main source of heat may be the body heat of the occupants.

Passage of natural air breezes through the building will serve to keep it cooler as well as to remove odors. The greatest amount of air can pass through the room if the inlet opening and outlet opening are directly opposite so that the air current need not change paths. The outlet opening should be larger than the inlet. Vertical louvers should be fitted to divert available breezes into the building. Dampers or shutters should be adjustable for control of ventilation. Shades against the sun and screens for privacy and protection against rain, glare, insects and intruders will decrease air circulation.

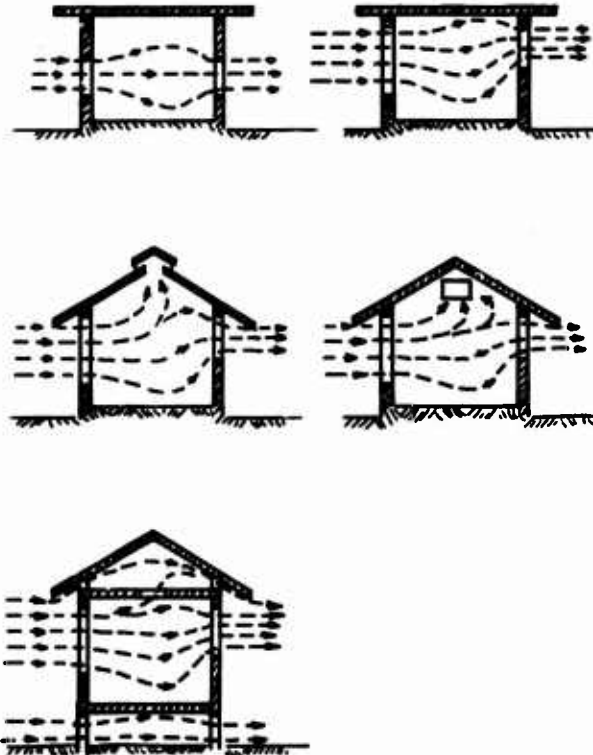

When winds are light the natural ventilation of buildings is dependent upon stack effect. This means that cool air enters at the bottom of room, rises as it is heated, and then is discharged as hot air through outlets high in the walls or roof. Use of a double ceiling with a vented void space will reduce heat gain from the sun.

## Building Layout

In a self-help operation, the natives will often be unskilled in building construction. To minimize waste of materials, they must be shown techniques for making buildings square, plumb, and level. A tape, a square, and some pegs are required for layout of the building. The square is easily made from boards using a triangular form with sides 3 feet, 4 feet, and 5 feet.

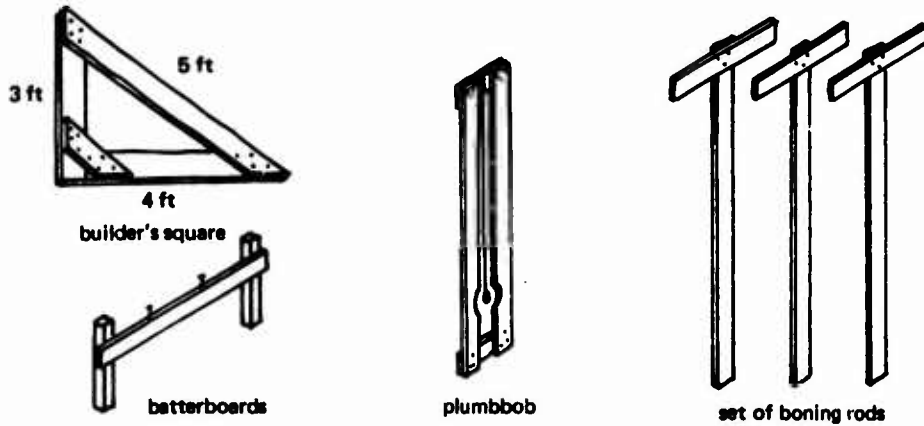

These general steps should be followed. Mark the building's corners with pegs. Use the square to obtain right angles, and check by measuring diagonals, which should be equal. Next set up wall profiles—batterboards with a board nailed across them and two nails driven into the top to indicate the correct width of the wall. The profiles are placed in position at each end of the wall but erected clear of the actual building area. String lines are then tied from nail to nail indicating the actual position and width of the wall: the profile should remain in place until the wall itself has been commenced, after which the wall is a sufficient guide.

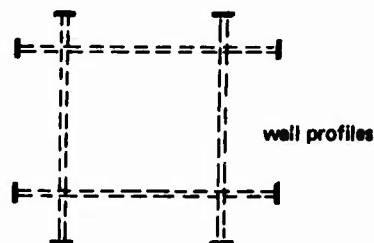
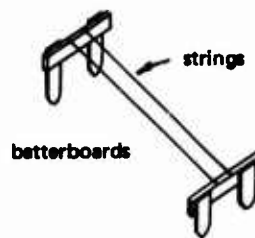
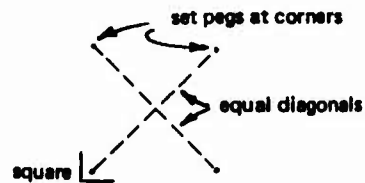

## FUNCTIONAL ELEMENTS OF BUILDINGS

### Foundations

Foundations for dwellings are intended to distribute the weight of the building on the supporting soil, to tie the building to the ground, and to elevate the building above the soil surface. Foundations may take the form of piles, piers, beams, or strips. They may be of timber, masonry, concrete block, or stabilized soil.

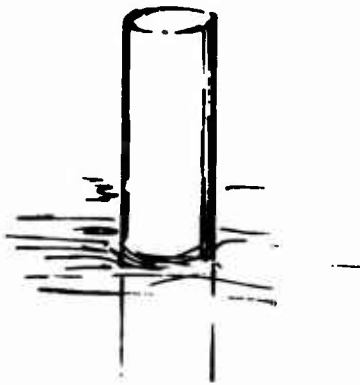

pile



pier

Piles or posts can be driven into the soil or placed in excavated or drilled holes which are later backfilled. Piles can be placed to given elevations or cut off at desired elevations.

Piers consist of isolated supports with bearing surfaces of sufficient area to carry the weight of the proposed building on a given soil. The piers are constructed with constant or varying cross section to form vertical supports for the girders, beams or joists of the floor frames.

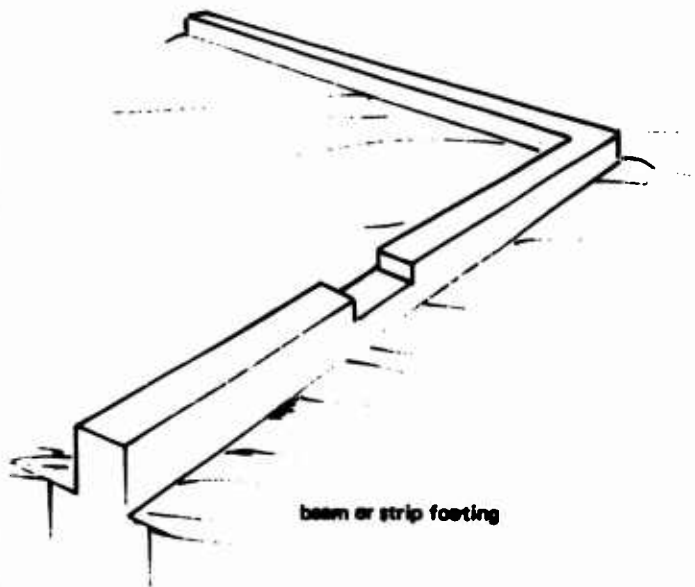

beam or strip footing

Beam or strip foundations are continuous versions of piers. They are placed around the perimeter of the building and at such inner locations as may be needed.

In constructing a typical strip footing, the foundation trench is dug, with depth and width depending on soil conditions and height of the wall. For most small buildings the foundation is twice the width of the wall. The bottom of the trench is leveled and for this a spirit level or boning rods are required. A flat metal tray filled with water and laid on a straight solid board or water in a bottle can be used as a substitute for a level. Pegs are driven along the center of the trench to proper level; at least three pegs are leveled with a spirit level. Other pegs can be set using boning rods. After the concrete has been placed in the trench the leveling pegs should be removed.

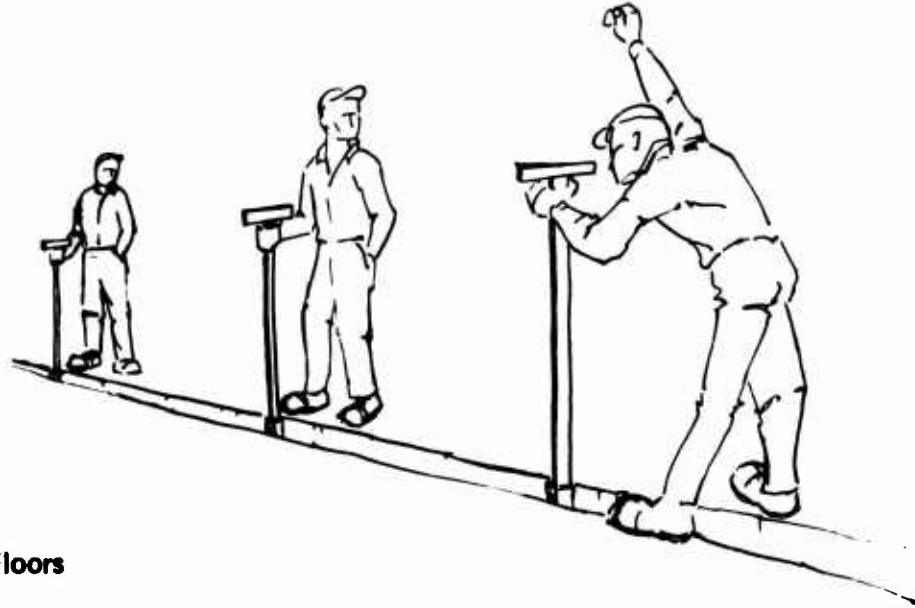

## Floors

Many primitive houses have no floors other than the surface of the earth; the surface should be raised above natural grade to prevent flooding of the living space; it can be compacted by tamping. Dirt floors can be paved with bamboo or other suitable native materials. If this is done the soil should not be compacted first, but after the bamboo canes are placed they should be pounded to drive them into close contact with the surface of the soil which is compacted by the same operation.

Floors raised above the ground are better from the standpoint of health and comfort. Floor framing and surfacing should preferably be of wood. If sized lumber is available this should be used. Table 1 provides information on the correct size of floor joists.

Raised floors can be made entirely of bamboo or other native vegetation. It is preferred that posts used to elevate floors be of concrete or of hard wood rather than materials which are subject to rapid destruction by termites or rotting. If there are periods of chilly weather, as in the mountains of the RVN, the floor may have to be covered with matting to provide comfort for the occupants.

Table 1. Floor Joists for 12-Inch and 16-Inch Spacing

(Designed for 30-psf live load and dead load; fiber stress of 1,200 pounds. Dead load includes weight of joist, 1-inch subfloor, and 1-inch finish floor.)

Span (ft)	Joist Dimensions (in.) for—	
	12-Inch Spacing	16-Inch Spacing
9	2 x 6	2 x 6
10	2 x 6	2 x 6
11	2 x 6	2 x 6
12	2 x 6	2 x 8
13	2 x 6	2 x 8
14	2 x 8	2 x 8
15	2 x 8	2 x 8
16	2 x 8	2 x 10, 3 x 8
17	2 x 8	2 x 10, 3 x 8
18	2 x 10, 3 x 8	2 x 10, 3 x 8
19	2 x 10, 3 x 8	2 x 10, 3 x 8
20	2 x 10, 3 x 8	2 x 12, 3 x 10

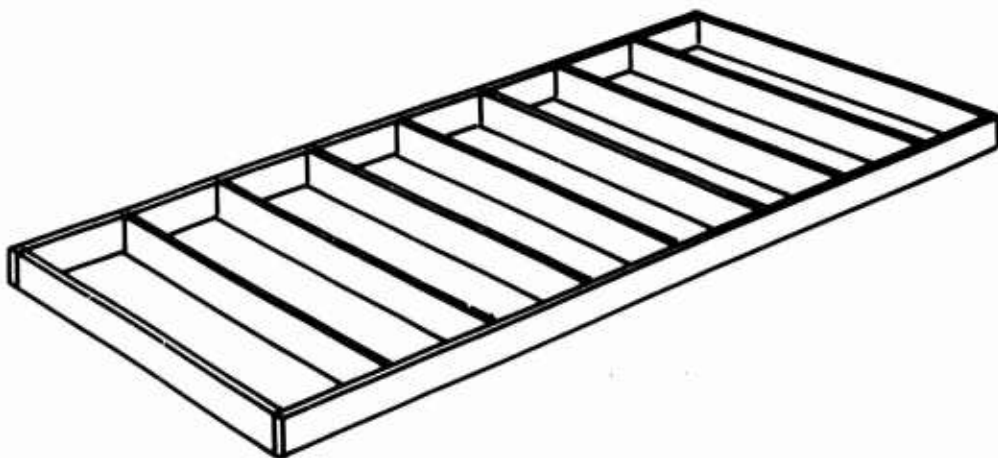

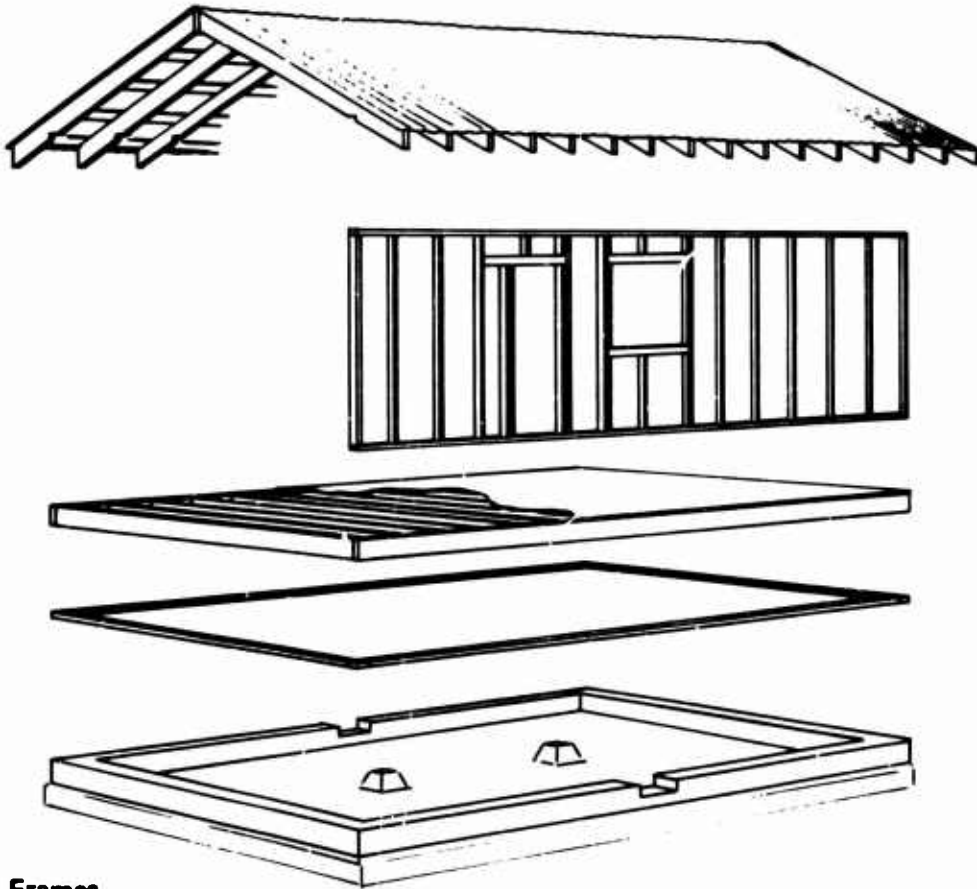

## Frames

Framed construction as applied to small buildings usually means that the load-carrying skeleton is of wood. The wood frames can be any of several types:

1. Stud wall, where the vertical loads are carried by 2 x 4-inch or similar sized vertical members spaced on approximately 16- to 24-inch centers. Top and bottom horizontal members, called plates, complete the wall sections.

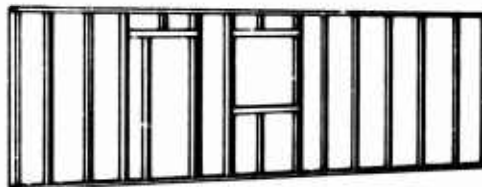

2. Column-and-beam, where the vertical members are approximately 4 x 4 inch, on approximately 4-foot centers. Horizontal members, 4 x 4 inch or similar, called beams or girders, are placed atop the columns.

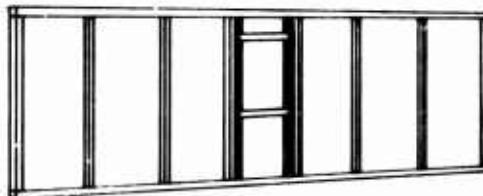

3. Post-and-beam, similar to column-and-beam except that the vertical members are imbedded in the ground.

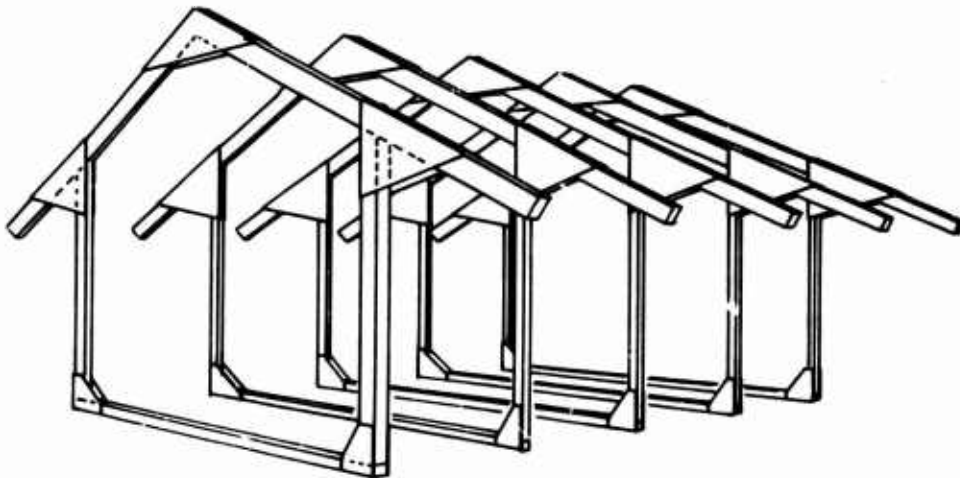
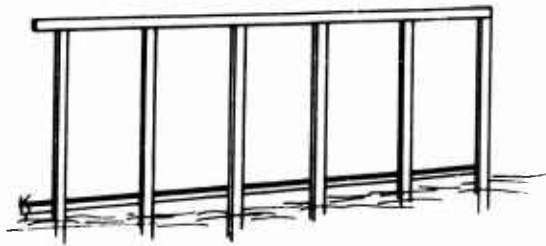

4. Rigid frames, where the connection between columns and beams or rafters is strengthened to prevent hinging between the members so that the whole frame acts as a single structural element.

5. A-frames, where inclined planes come together to combine wall and roof functions.

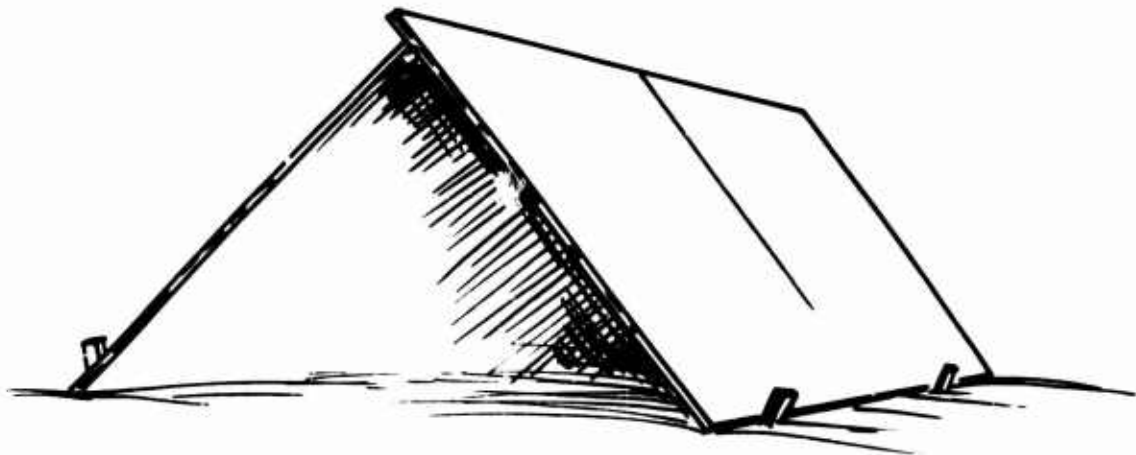

Probably the most critical factor in framed construction is the connecting method. Nailing, bolting and tying are all commonly used; these should be of sufficient quality and quantity to prevent separation of the members under all probable loadings. Common steel nails are most often used; 16-penny for framing, 20-penny for heavy structurals, 12-penny for sheathing and flooring, 10-penny for light wood members. Finishing nails are used for fine woodwork and roofing nails are used for attaching roof surfacing. If metal sheets are nailed, do not attach with nails of dissimilar metals. Gussets, brackets and braces of wood or metal are often used in wood frame construction.

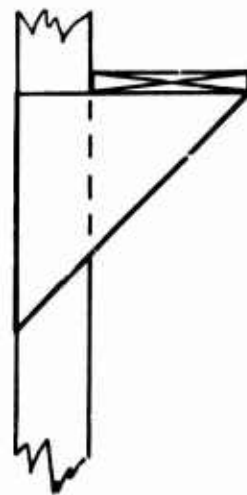
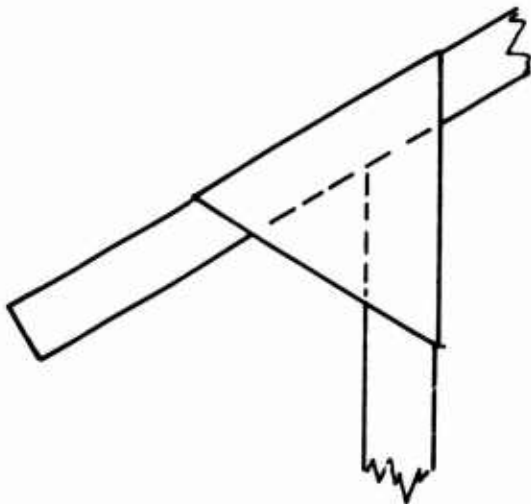
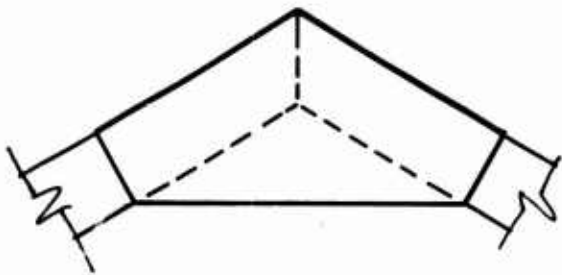
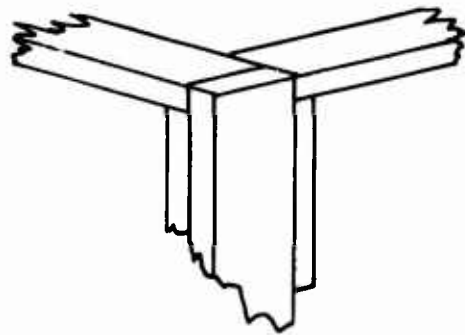
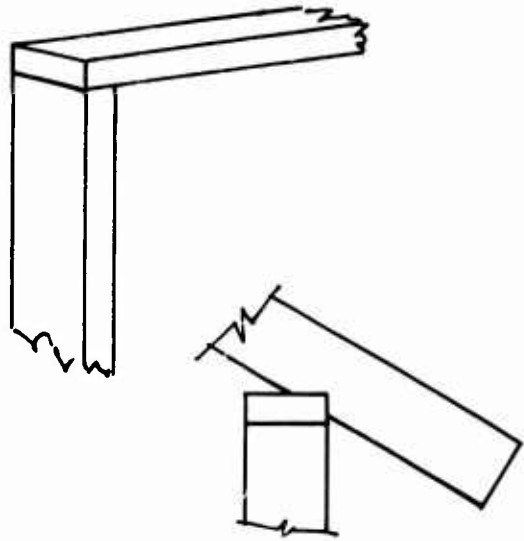

## Walls

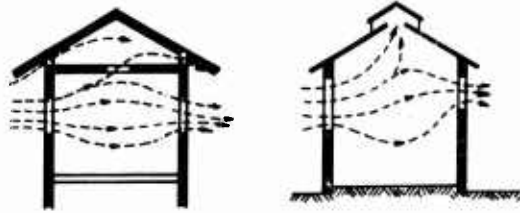

In humid regions, the need for high ventilation rate and lightweight construction makes it desirable to have openings form a major part of north- and south-facing walls. Walls should be shaded as much as possible by overhanging eaves, and additional horizontal and vertical shading devices can be used.

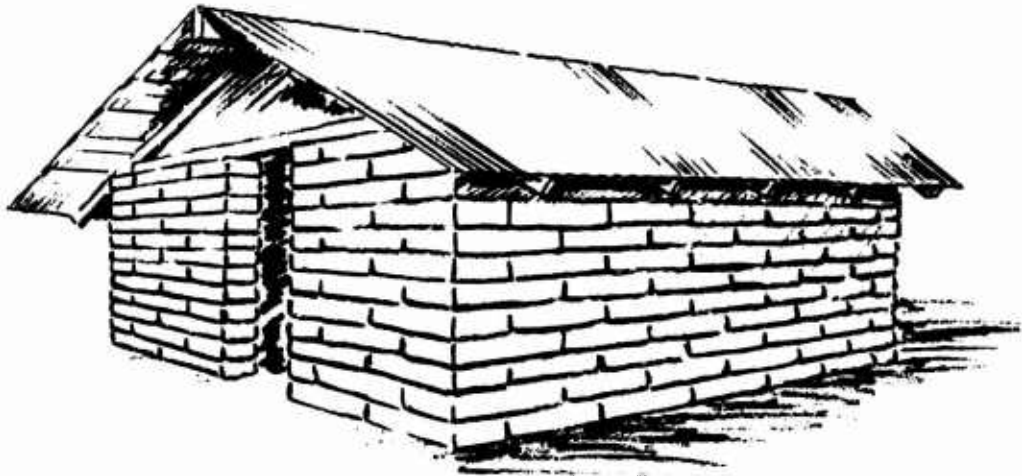

Additional masonry wall construction is of load-bearing type. Brick or mud-block load-bearing walls are generally at least 8 inches thick. Filler walls are sometimes used where concrete or other strong frames support the roof. Filler or curtain walls of 4-inch thickness are commonly used. Lime or cement or lime-cement mortars are commonly used; occasionally mud mortars are employed. Most block-work or earthwork walls are rendered on both sides with sand and cement stucco. It combines the functions of waterproofing and decorating.



A suggested stucco mix is 1:2:9 or 1:3:12 cement-lime-sand using well-graded sand. Keying can be provided by pegs or wire netting or large-headed nails driven directly into the wall. Hacking or scouring of the wall surface to a depth of about 1/2 inch will generally provide sufficient key. If the wall is very dry, the surface should be moistened before the rendering is applied. If cement and lime are not available, a wall coating made of a stiff mix of sand and clay can be applied by trowel.



If the surface of the wall is soft or flaky, only whitewash coatings should be used. Tests of coatings of polyvinyl acetate emulsion, styrene emulsion, or alkyd emulsion paints may be required to prove their suitability. Oil paints and bitumen or tar paints have advantages of low permeability to water. The black color of bitumen paint can be disguised by tossing sand on the tacky surface or by use of aluminum pigment in the finishing coat. Lime wash can be used after the sand has been applied to the surface.

## Roofs

Because of the importance of the roof structure in reducing solar heat gain, this factor (insolation) should be considered first. Roofs should preferably be lightweight and the external surfaces should reflect solar heat. In humid areas such as RVN little insulation is ever necessary. Double roofs or ceilings should be provided wherever possible. Means for ventilating the inner space between roofs or roof and ceilings should be provided. In hurricane regions, roof vents should be provided near the ridge in order to reduce aerodynamic lift.

Double-pitched roofs are suitable where high wind speeds occur. Shed roofs are satisfactory where maximum wind speeds are not excessive and may be cheaper than double-pitched roofs. Flat roofs should not be used in wet climates.

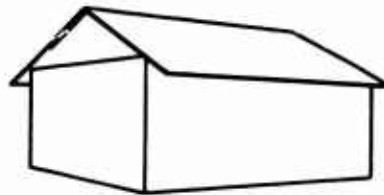

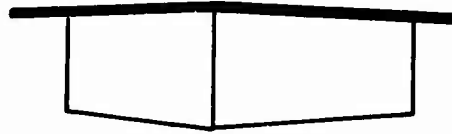
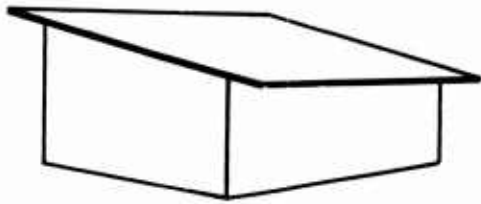

A gabled roof with wide overhang is more effective in shading than is a hip roof. Shading of south-facing walls can be particularly effective. Only partial shading need be provided by the roof for east- and west-facing walls.

Large quantities of water are shed by the roof during heavy rain storms. Care should be taken that water running off the roof does not cause local flooding.

Roof coverings of grass or other vegetation are used in the rural areas; clay tiles, asbestos-cement or galvanized steel sheets are used in urban areas.

Four types of roof framing are in common use: rafter and joist frames, light wooden trusses, ridge support systems and flat-roof joist systems. For sloped roofs a simple triangle of timbers is used. Variations include the simple frame augmented by a collar tie, diagonal braces, or panels. The basic truss action is apparent in the simple frame. The action involves a thrust, produced at the heels of the trusses by the loaded rafters, which must be resisted by the tying action of ceiling joists. The most important joints in the truss are the heel joints and the ceiling joist tension splices. The bending resistance of the rafter is also a significant part of the roof frame strength. The secondary bracing members (in variations of the simple frame) are used as intermediate supports to reduce the spans which determine rafter sizes. The secondary brace members also have a varying but important effect on the thrust. Member sizes for roof frames are based on the design loads, the span of the frames, spacing in which the frames are used and the species and grade of lumber used. Timber trusses made of small-dimension short-length pieces can be joined with nails or with ties. An important consideration is the manner in which the trusses or roof frames are joined together. Very often the weakest part of a truss or roof frame is in the nailing, and in some cases only a small fraction of the capacity of the lumber is properly utilized because of improper nailing or other type of joining.

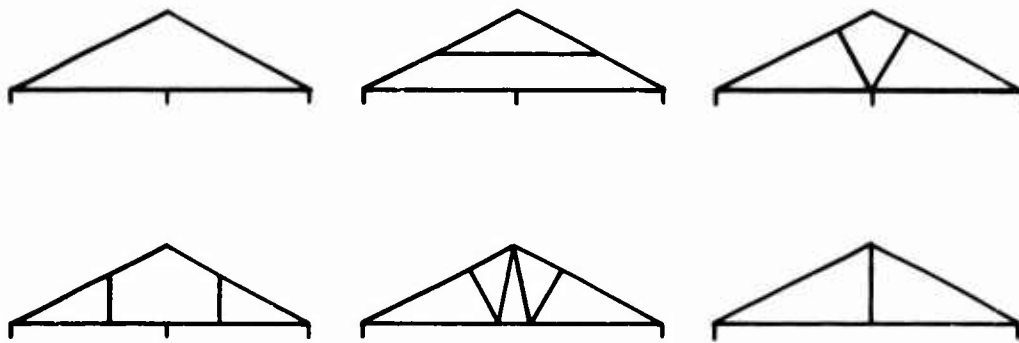

Lightweight wooden trusses have the advantage of prefabrication; they allow the structure to be built more rapidly and give freedom to the location of partitions. The simplest trusses are of the W or King-post type. Small numbers of trusses are usually built in a simple jig laid out on a convenient surface.



For low-slope roofs, the ridge support system provides a means of eliminating thrust by providing a support along the ridge. The rafters bear on the center ridge support and on the exterior walls and thus resist the load by simple beam action with no thrust being produced. Support of the ridge normally takes the form of a beam which can span any distance up to the full length of the roof. Another method involves the upward extension of a center bearing wall to a position where the rafters can bear directly on its top plate. A flat roof joist system can be considered a variation of the ridge support system.

Another roof framing system is the post and beam system, which consists of posts or columns supporting beams which in turn support covering materials. Member sizes and spacing and spans are considerably larger than used in rafter roof systems.

Roof systems often require secondary members to which the roof covering is attached. Roof secondary members can be boards or poles spaced so that air can circulate and thus keep unwanted moisture from the underside of the roof. Solid wood sheathing is sometimes used as a roof cover with surfacing of tar paper, asphaltic felt sheeting or plastic sheeting.

## MATERIALS

### Earth

Earth is a mixture of aggregate (sand, silt, gravel) and clay, which acts as a binder. Too much aggregate results in crumbling; too much clay causes excessive shrinking and cracking. About five parts aggregate to one part clay is the best mixture.

Earth has obvious advantages as a building material. It is abundant, usually found near building sites, and can be placed by relatively unskilled labor. However, a number of variables affect the final product (Table 2)—fairly close supervision is required, and the resulting structures may have limited strength and require surface treatments to protect them. Some prior experimentation at the site is advised before earth is used in actual construction.

The two principal stabilizers used in earth construction are cement and emulsified bitumen (asphalt), Table 3. Vegetable or animal oils are used in rare cases.

Earth for rammed construction has an optimum moisture range. A soil containing 40% sand will require about 15 to 20% water; a soil with 70% sand will need about 10% water. To test, press a handful of the mixture into a ball, then drop on hard ground from shoulder height. If the ball breaks into its original loose state, the consistency is correct; if it breaks into larger unfragmented pieces, it is too wet.

The degree of compaction of the soil is measured by the weight of the solid material, excluding moisture, which can be forced into a given volume. The higher percentage of sand to clay, the greater compaction will be required. For each soil there is an optimum moisture content at which a given amount of ramming will produce maximum compaction.



Earth walls may be constructed either by ramming into forms on site or from earthen blocks, which are laid up with a mortar of the same material. Solid walls are subject to cracking and should be kept to 8-foot lengths between expansion joints. Block work requires less supervision and is more suitable to the production of small units. Solid forms must be of heavy planks and be well braced to withstand the forces of ramming as the soil is placed. The ramming tools should weigh 12 or 15 pounds and should be made of steel or steel-shod wood. The rammer should be raised about 12 inches and a considerable force applied on the downward strokes. The soil should be placed in layers about 3 inches thick before ramming. Earth walls should be at least 8 inches thick.

Blocks are made in forms in which earth is rammed tightly. Blocks may be of any size that can be handled; 16 x 8 x 4 inches is suggested. Blocks should be formed on pallets; they should not be handled before curing. They should be damp-cured for 7 days, then air-dried for 21 days. They can be laid with a mortar of the same material, but with water added so that it can be easily worked with a trowel. Adobe blocks can be made on the site if clay is available. The mud is mixed with straw or grass fibers, placed by pouring in molds, and dried in the sun.

Cob walls are built of stiff mixtures of clay, straw and water which is built up in layers without forms and then pared or trimmed to the proper wall dimension and shape. Daub construction is a rough coating of clay mud applied by hand or trowel like stucco to a supporting framework of lath or brush.



Table 2. Effects of Variables on the Quality of Rammed Earth Construction\*  
(Portland cement as possible stabilizer)

Variable	Effect of Variable on Finished Product
<b>Strong binder ("active" clay)</b>	
High percentage	High strength; shrinks and swells
Low percentage	Low strength; slakes in water
<b>Weak binder ("inert" clay) e.g. kaolin</b>	
High percentage	Lower strength; less shrinkage; slakes in water; requires cement
Low percentage	Very low strength; porous; slakes in water
<b>Aggregate (sand)</b>	
High percentage	Very low strength; porous; suitable for concrete
Low percentage	High strength; shrinks and swells; more cement needed for stabilization
<b>Soil mixture</b>	
Coarse	Mixing difficult; nonuniform weak product; crumbles
Fine	Facilitates mixing and distribution of cement; uniform product
<b>Vegetable matter (organic)</b>	
High percentage	Interferes with setting cement; liable to decay and to cause deterioration of product
Low percentage	Interference with setting of cement may be reduced by addition of about 1% of calcium chloride
<b>Water</b>	
Wet mix	Difficult to ram; shrinks
Dry mix	Difficult to ram; dense; porous; crumbles
<b>Ramming</b>	
Appreciable	High strength and density
Light	Low strength; more shrinkage; porous; crumbles
<b>Cement</b>	
High percentage	High strength; reduces shrinkage; less slaking in water; may be cheaper to use a wet mix and make concrete
Low percentage	Compared to rammed earth; without cement, increases wet strength; less shrinkage; less slaking in water

\* From Colonial Building Notes No. 8, Building Research Station, Watford, Herts., August 1952.

Table 3. Stabilizer Components Added for Typical Soils\*

(Soils measured by dry weight. Percentage of emulsion does not include additional water required for plasticity.)

Cement	
Approximate Composition of Soil	Stabilizer Added (%)
90% sand, 10% clay	5
70% sand, 30% clay	8
60% sand, 40% clay	12
50% sand, 50% clay	15
Emulsified Bitumen	
Basic Types of Soil	Stabilizer Added (%)
with high sand content	4 to 6
with medium sand content	7 to 12
fine clay	13 to 20

\* From Colonial Building Notes No. 8, Building Research Station, Watford, Herts., August 1952.



Supporting walls of earth should be at least 8 inches thick but curtain walls may be of 4-inch thickness. Earthwork columns 2 x 3 feet in cross section, placed on 8-foot centers, will support roof trusses spanning 25 feet.

Earthwork should be covered with wide overhanging roofs to protect against rain erosion. Maintenance in the form of patching or wall coating is essential.

## Concrete

**Ordinary Mixes.** Concrete consists of portland cement, sand, gravel or crushed rock, and water. It is usually mixed near the site where it is used. The proportions of cement, fine and coarse aggregate, and water can be varied to obtain a desired strength and workability.

The strength of concrete depends on the water—cement ratio. When the ratio is high, strength is low. When the ratio is low, strength is high. Water increases the workability and permits the use of more aggregate at a given mix consistency. The ideal amount of cement is that which will coat each particle of aggregate and fill all voids. Concretes with too much sand will be more subject to shrinkage and cracking than optimum mixes. A typical mix for slabs and walls in small buildings is 1 part cement, 2 parts sand, and 4 parts gravel or crushed rock, with sufficient water to get a slump of approximately 3 inches. Parts should be proportioned by weight if possible.

Small batches of concrete should be mixed for about 2 minutes. Larger batches can be mixed for longer times, but never longer than 20 minutes. Concrete is cured by preventing the evaporation of water from its surface. The surface should be kept wet or covered for 7 days to prevent evaporation.

**Coral Concrete.** Dense coral makes good general purpose concrete. Finger coral is light, fragile, and porous; it makes an inferior concrete that is lower in strength, difficult to place, and likely to result in honeycombed structures.

A mix satisfactory for walls, footings, and rough finished slabs consists of 6 bags of cement per cubic yard of coral in which the proportion of coarse to fine approximates 2 to 1. Six gallons of water per bag of cement with this mix will produce a smooth wall finish. For hard surfaced floors, 8 bags of cement per cubic yard of coral finished with a steel trowel will give a hard, smooth surface.

Coral concrete should be mixed for at least 90 seconds. It can be placed in any type of form or mold; reinforcing steel can be used effectively.

**Seawater in Concrete.** Compressive strength is little affected by using seawater for mixing concrete. Concrete mixed with seawater may test from 10% to 20% lower in compressive strength than similar concrete mixed with fresh water. This reduction in strength is easily corrected by re-proportioning the mix, using less seawater and more cement. Comparative tests for durability are not available. When seawater mixes must be used for reinforced concrete structures subject to frequent cycles of wetting and drying, the concrete must fully encase the steel.

Because seawater accelerates the setting of concrete, it may be difficult to continuously pour large structures.

No special cement is required to obtain satisfactory results when coral aggregate and seawater are used.

**Watertight Concrete.** The mixture must be proportioned to completely incorporate sound aggregates in a watertight paste. A watertight paste necessitates strict control of the mixing water. Water should not exceed 5-1/2 gallons per sack of cement. This includes water entering the batch as free moisture on the aggregate. The mixture should contain not less than 7 sacks of cement per cubic yard of concrete. Maximum size of aggregate should be not larger than 1/6 the smallest dimension of the structural member to be poured and in no case larger than 1-1/2 inches. Vibrators are required to permit placing concrete of low water-cement ratio without increasing the cement content. Concrete should be kept wet for at least a week while it cures.

**Lightweight Concrete.** Lightweight concrete is less strong than ordinary concrete but its low density permits structural economies and easy handling. It also provides better thermal insulation than ordinary concrete. Because of its lower strength, lightweight concrete calls for greater mix control and greater care in placing and curing than dense concrete.

Lightweight concrete can be made by (1) using aggregates that contain air voids, (2) introducing air or gas bubbles into a plastic cement mix so that it sets up as an aerated, cellular structure, (3) using coarse, single-sized aggregates that produce a concrete with large voids ("no-fines" concrete).

Lightweight aggregates include clinker, foamed slag, expanded clay and shale, expanded vermiculite, expanded perlite, pumice, diatomite, sugar cane pulp, rice husks, and sawdust. The workability of lightweight aggregate concrete is obtained by using a richer mix, by increasing the proportion of fines, by adding sand or incorporating an air-entraining agent. Workability cannot be obtained by adding more water as this causes segregation. When mixing lightweight concrete, first wet the aggregate by spraying with water until a moist surface condition is obtained. The cement and a little additional water should then be added. Simple form work can be used because lightweight concrete exerts little hydrostatic pressure. The frames can be of woven wire mesh, expanded metal or plywood attached to a suitable stout frame. The concrete is consolidated by tamping or vibrating. Lightweight aggregate concrete is often used in block form. The blocks are usually vibrated and compacted, although sometimes they are only tamped.

Aerated concrete is produced by chemically generating gas bubbles within the mix or by using a foam to entrain air bubbles. To chemically aerate concrete, a fine aluminum powder is added to the cement mix; the proportion of the aluminum is 0.2% of the weight of cement. The metal powder reacts with the cement to form hydrogen bubbles. As an alternative, hydrogen peroxide and bleaching powder can be used to generate oxygen bubbles.

To produce a preformed foam, hydrolized proteins or resin soaps are added to water and the mixture is mechanically aerated. Cement and aggregate are mixed to a dry or semiplastic consistency, and the preformed foam is then added; mixing for around 1 minute is usual. Aerated concrete is used for precast blocks and slabs or can be cast on site.

No-fines concrete is composed of cement and coarse aggregate only; sand is omitted. This concrete is cellular with many uniformly distributed voids and is used for cast-in-place, low-bearing capacity walls and partitions; it can also be used as a subfloor. External surfaces have to be rendered with cement mortar to make them water resistant. Weight of no-fines concrete is  $\frac{2}{3}$  that of normal concrete. Tensile and compressive strengths of no-fines concrete are much lower than those of normal concrete, and bond strength is low. The water resistance of a no-fines concrete wall with suitable rendering and good detailing is excellent. This is because no-fines concrete is cellular and there are few capillary paths along which moisture can pass through the wall. No-fines concrete dries out much more rapidly than ordinary concrete; form work can be stripped much sooner.

There is appreciable saving in cement if no-fines concrete is used in place of normal concrete. A cement-coarse aggregate ratio of  $\frac{1}{8}$  by volume is generally used. Wall thicknesses are 6 inches.

No-fines concrete uses either dense or lightweight aggregate of  $\frac{3}{4}$ -inch to  $\frac{3}{8}$ -inch size. In mixing no-fines concrete, the dry aggregate should be wetted before the cement is added and then mixed for around 2 minutes with little additional water. The aim is to coat the aggregate evenly with the cement grout; too little water or too much water weakens the concrete. If the correct water content is used segregation will not occur when a sample of the mix is dropped. For no-fines concrete, light forms can be used because the hydrostatic pressure against the vertical surfaces of the forms is less than for dense concrete. The concrete should be placed in position as soon as possible after mixing. When used for walls it should be poured in a series of horizontal layers. It should not be permitted to build up in a heap as the sloping faces create planes of weakness. Construction joints should be avoided and all the concrete should be placed in one continuous operation. No-fines concrete should not be rammed, but light rodding may be necessary.

## Concrete Blocks

Concrete blocks are usually made as multiples of brick sizes. In the United States, a nominal concrete block size is 16 x 8 x 8 inches. Half-length blocks are usually needed during the layup process, and there may be some need for blocks of the half depth dimension. Blocks can either be solid or hollow-cored. When dense concrete is used, the blocks are usually cored. Concrete blocks can be made to any size that can easily be handled. The cost of units per cubic foot of wall does not vary greatly with the unit size; but the smaller the unit the higher the cost of mortar and labor.

Preferences are for the simple rectangular block intended to be laid in mortar; these are simple to make and lay. Special blocks with interlocking joints or keys or special shapes introduce complications in making and laying. Blocks to be laid without mortar must be made to extremely small tolerance; unevenness will concentrate loading and will cause failure of the blocks.

Blocks can be cast in simple wood or metal molds. Coating molds with oil will aid block release. Compaction is by hand tamping. Various types of block-making machines are manufactured; these range from hand-operated, hand-compaction types to complicated installations using power equipment and power vibration. A good compromise solution is to use simple box molds which are filled by hand, and power vibrating tools or a vibrating table upon which the molds are placed. Since the molds are removed soon after casting, the green blocks are very fragile and therefore require the rigid support of wood or metal pallets.

Types of aggregate which may be used include crushed stone, gravel, sand, and coral. Portland cement types 1, 2, or 3 may be used. Water should be free from harmful impurities such as oils, acids, or organic matter. The mix should not be richer than 1 part cement to 6 parts of mixed fine and coarse aggregates. If possible use weight-batching; this is more accurate than volume batching.

As much water should be added to the mix as will produce a water sheen on the surface of the block and still not cause the block to slump. The blocks are cured by stacking in a sheltered position in such a way that the air can circulate freely around each one. The blocks are kept moist for about 5 days and then allowed to dry slowly. In hot, humid climates, it is probably advantageous to initially stack the blocks close together to restrict air movement through the stack and reduce evaporation. After 10 days the blocks should be restacked to allow air to circulate freely and then left for a week of curing. If high early strength cement is used, the total curing period may be reduced to 7 days.

Concrete blocks should be kept dry before, during, and after layup. They should be stacked so that the air circulates around them and should be protected from rain by covers. When ready for laying, the blocks should not be thoroughly wet but should be lightly sprayed with water.

Concrete block walls are normally not very resistant to rain penetration. It may be necessary to render (stucco) the outside of the walls as the mortar joints are vulnerable when heavy rain is experienced. The rendering is applied by trowel. It should be a 1:1:6 cement-lime-sand mix and should not be applied until the wall is dried out, or until the water content in the wall has reached equilibrium with the surrounding air; the concrete block can be coated with whitewash or with special paints for concrete surfaces.

Joints which are raked or struck greatly increase the possibility of leaks developing in unrendered walls. A weak mortar is preferable to one rich in cement; rich or strong mortars make a wall too rigid, localizing the effect of minor movements. This may lead to cracking of the blocks thus creating a path for termites and entrance of driving rain. A recommended bedding mortar is 1 part cement, 1 part lime, and 6 parts of sand. The tops of walls should be temporarily covered during construction to prevent the entrance of rain.

### Plastics

Plastics are not generally used where they would be subjected to structural loads. Thermosetting plastics have high strength under compressive loads but are unable to deform elastically to relieve stress concentrations; they exhibit brittle fracture characteristics. These plastics also exhibit decline in strength under tensile loadings. Thermoplastics soften and deform permanently in the presence of heat.

When plastics are used for non-load-bearing purposes, they should be carefully evaluated from the standpoints of combustibility, surface spread of flame, and penetration by fire, as well as for the production of smoke and toxic fumes during a fire situation.

The most common form of plastic cladding material is glass fiber reinforced polyester. This usually comes in corrugated sheets, which can be nailed to wood framing. The material comes in various colors and with various light transmission factors. A good use of this material is in daylighting (skylights or windows) of buildings. Heat gain may be excessive if large areas of walls or roofs are covered with the material.

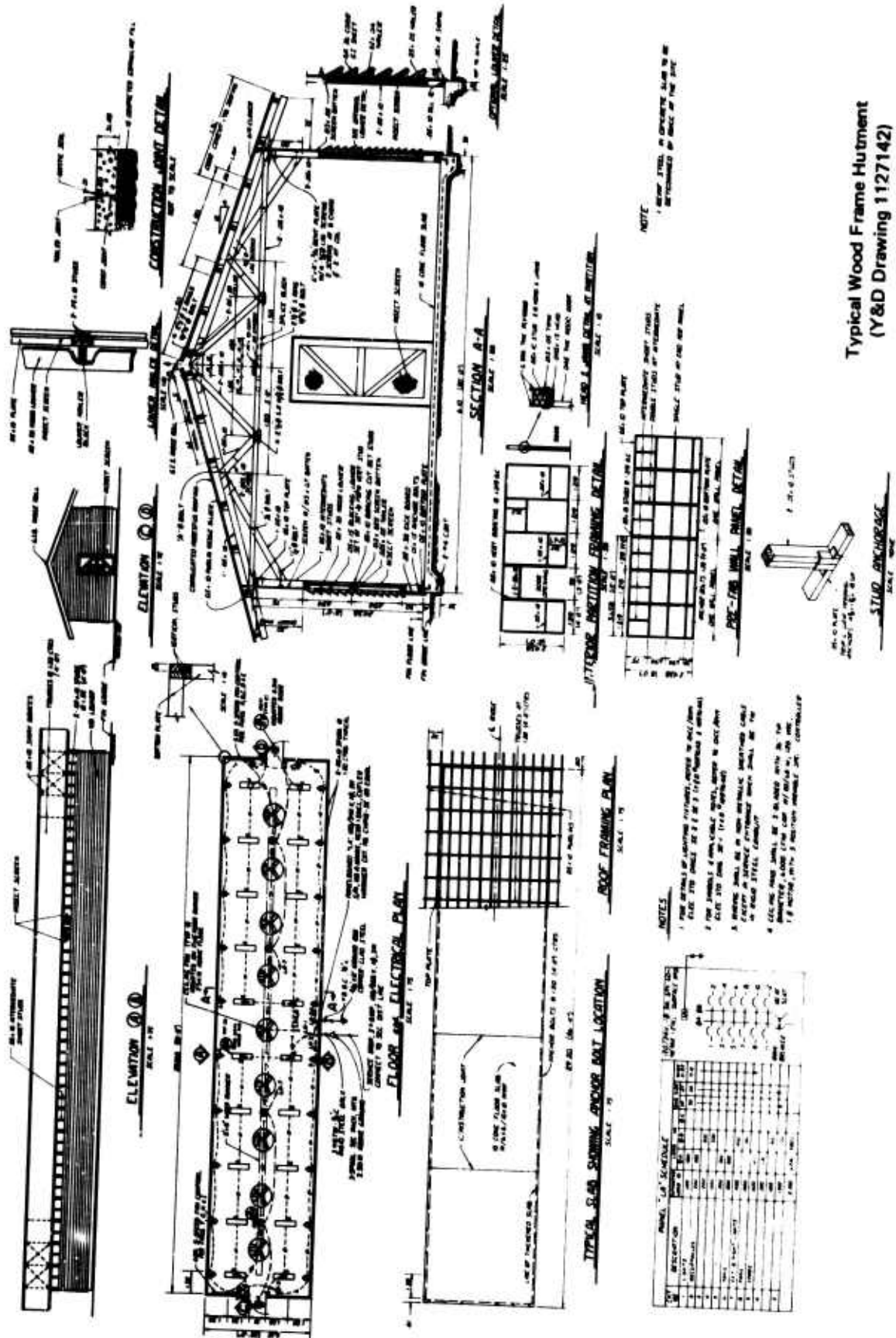

Typical Wood Frame Hutment  
(Y&D Drawing 1127142)

TABLE S-58

NO.	DESCRIPTION	QUANTITY	UNIT	REMARKS
1	STEEL ANCHOR BOLTS	12	EA	
2	CONCRETE	1.5	CU YD	
3	WOOD FRAMING	100	SQ FT	
4	STEEL STUDS	100	EA	
5	STEEL CHANNELS	100	EA	
6	STEEL PLATES	100	EA	
7	STEEL RODS	100	EA	
8	STEEL WELDS	100	EA	
9	STEEL BRACKETS	100	EA	
10	STEEL BOLTS	100	EA	
11	STEEL NUTS	100	EA	
12	STEEL WASHERS	100	EA	
13	STEEL BRACES	100	EA	
14	STEEL GIRDERS	100	EA	
15	STEEL JOISTS	100	EA	
16	STEEL TRUSS	100	EA	
17	STEEL PURLINS	100	EA	
18	STEEL RAFTERS	100	EA	
19	STEEL COLLARS	100	EA	
20	STEEL END PLATES	100	EA	
21	STEEL GUSSET PLATES	100	EA	
22	STEEL BRACE PLATES	100	EA	
23	STEEL CONNECTION PLATES	100	EA	
24	STEEL END BRACES	100	EA	
25	STEEL BRACE RODS	100	EA	
26	STEEL BRACE NUTS	100	EA	
27	STEEL BRACE WASHERS	100	EA	
28	STEEL BRACE BOLTS	100	EA	
29	STEEL BRACE PLATES	100	EA	
30	STEEL BRACE RODS	100	EA	
31	STEEL BRACE NUTS	100	EA	
32	STEEL BRACE WASHERS	100	EA	
33	STEEL BRACE BOLTS	100	EA	
34	STEEL BRACE PLATES	100	EA	
35	STEEL BRACE RODS	100	EA	
36	STEEL BRACE NUTS	100	EA	
37	STEEL BRACE WASHERS	100	EA	
38	STEEL BRACE BOLTS	100	EA	
39	STEEL BRACE PLATES	100	EA	
40	STEEL BRACE RODS	100	EA	
41	STEEL BRACE NUTS	100	EA	
42	STEEL BRACE WASHERS	100	EA	
43	STEEL BRACE BOLTS	100	EA	
44	STEEL BRACE PLATES	100	EA	
45	STEEL BRACE RODS	100	EA	
46	STEEL BRACE NUTS	100	EA	
47	STEEL BRACE WASHERS	100	EA	
48	STEEL BRACE BOLTS	100	EA	
49	STEEL BRACE PLATES	100	EA	
50	STEEL BRACE RODS	100	EA	

NOTES

1. THE DETAILS OF CONNECTIONS BETWEEN STEEL AND CONCRETE SHALL BE AS SHOWN IN THIS DRAWING UNLESS OTHERWISE SPECIFIED.
2. THE DETAILS OF CONNECTIONS BETWEEN STEEL AND WOOD SHALL BE AS SHOWN IN THIS DRAWING UNLESS OTHERWISE SPECIFIED.
3. THE DETAILS OF CONNECTIONS BETWEEN WOOD AND WOOD SHALL BE AS SHOWN IN THIS DRAWING UNLESS OTHERWISE SPECIFIED.
4. ALL STEEL SHALL BE A36 UNLESS OTHERWISE SPECIFIED.
5. ALL WELDS SHALL BE E70 UNLESS OTHERWISE SPECIFIED.
6. ALL BOLTS SHALL BE A325 UNLESS OTHERWISE SPECIFIED.
7. ALL NUTS SHALL BE A325 UNLESS OTHERWISE SPECIFIED.
8. ALL WASHERS SHALL BE A325 UNLESS OTHERWISE SPECIFIED.
9. ALL BRACE RODS SHALL BE A325 UNLESS OTHERWISE SPECIFIED.
10. ALL BRACE PLATES SHALL BE A36 UNLESS OTHERWISE SPECIFIED.
11. ALL BRACE BOLTS SHALL BE A325 UNLESS OTHERWISE SPECIFIED.
12. ALL BRACE NUTS SHALL BE A325 UNLESS OTHERWISE SPECIFIED.
13. ALL BRACE WASHERS SHALL BE A325 UNLESS OTHERWISE SPECIFIED.
14. ALL BRACE PLATES SHALL BE A36 UNLESS OTHERWISE SPECIFIED.
15. ALL BRACE RODS SHALL BE A325 UNLESS OTHERWISE SPECIFIED.

## CONSTRUCTION OF TYPICAL WOOD FRAME HUTMENT

An example of a typical wood frame hutment is shown in Y&D Drawing 1127142. This shows a frame of prefabricated wall panels combined with a roof system of prefabricated trusses and purlins. The entire frame is composed of wood members of nominal 2 x 4-inch size. The framing system provides a building width of 20 feet and length which would be some multiple of 4 feet. As shown in the drawing, the hutment is placed upon a concrete slab; the roof covering is of corrugated asbestos or galvanized steel sheets; and the sides and ends are covered with fixed louvers for the lower two-thirds and insect screening for the upper one third of their heights. Certain details shown in the drawing require hardware which is not always available. However, the basic features of the building are such that substitution of details of construction could be readily accomplished.

For construction of a 20 x 48-foot hutment the first three steps would be:

**Step 1.** Selection and preparation of site

**Step 2.** Layout of site

**Step 3.** Installation of floor system (concrete slab or wood floor on joists and beams supported on concrete or timber piers)

Steps 4 through 8 are presented in greater detail below.

**Step 4.** Fabrication of frame element

a. Side wall panel frames, 8 required—each wall panel consists of nominal 2 x 4-inch wood members

1 bottom plate, 12 feet long—drill bottom plates for anchor bolts at spacings of 4 feet

1 top plate, 12 feet long

4 studs, 7 feet 8-3/4 inches long

3 short studs, 2 feet 3-9/16 inches long

9 horizontal braces, 3 feet 9-13/16 inches long

Assemble side panel frames as shown in drawing. Use two 16-penny nails at each connection. Studs fit inside top and bottom plates, horizontal braces fit between studs, and intermediate short studs fit between top plate and upper horizontal braces.

- b. End wall panel frames, 2 required—each end wall panel consists of nominal 2 x 4-inch wood members

2 bottom plates, 8 feet 2-3/8 inches long—drill bottom plates for anchor bolts at spacings of 4 feet

1 top plate, 19 feet 4-3/4 inches long—may be made by joining shorter pieces end-to-end

8 studs, 7 feet 8-3/4 inches long

4 short studs, 2 feet 3-9/16 inches long

12 horizontal braces, 3 feet 9-13/16 inches long

2 door lintel members, 3 feet long

Assemble end frames in same manner as side frames. Leave clear height of 7 feet 6 inches at door opening.

- c. Roof trusses, 13 required.

The roof trusses consist of wood members arranged to provide a rise of 4 inches for each 12 inches of horizontal dimension. The top and bottom chords of the trusses, the side braces and short braces, and splice blocks are of nominal 2 x 4-inch dimension, while the center braces are of nominal 1 x 4-inch dimension. Collar plates are of nominal 2 x 8-inch lumber. Each truss consists of:

2 top chords, nominal 2 x 4s, 14 feet 10 inches long

4 bottom chords, nominal 2 x 4s, 10 feet long

2 side braces, nominal 2 x 4s, 3 feet 6 inches long

2 short braces, nominal 2 x 4s, 1 foot 10 inches long

1 splice block, nominal 2 x 4s, 1 foot 8 inches long

4 center braces, 1 x 4 inches by 3 feet long

2 collar plates, 2 x 8 inches by 1 foot 6 inches long

4 scab plates, 1 x 4 inches by 9 inches long

Use of a jig for fabrication of the roof trusses will save time and insure uniformity in the components. The jig can be a simple layout of a flat surface with cleats or stops arranged so the wood members fall in precise position. Connections of the members can be with bolts as shown in the drawing or alternative methods

of connection may be used. Two 20-penny nails or four 1/4-inch screws should furnish joints as strong as those secured with a single 1/2 inch bolt.

- d. Roof purlins are the longitudinal members placed atop the trusses to which the roof sheathing will be nailed. The system shown in the drawing provides for purlins of nominal 2 x 4-inch lumber spaced at 26-1/2 inches. Required lumber would be 672 linear feet. Blocks of 2 x 4-inch lumber nailed downslope of the purlins are often used to improve the fixity of the roof purlins. These blocks are attached with 20-penny nails to the trusses at 26-1/2-inch spacing during prefabrication.

**Step 5. Erection of structural frame**

- a. Place all prefabricated trusses on building floor
- b. Position all prefabricated side-wall and end-wall frame panels around perimeter of floor with intended bottom edges of the panels nearest the floor.
- c. Tilt up one end section into place, with the bottom plate lined up with the tie-down bolts. Set temporary braces to hold end section in place.
- d. Tilt up first side-wall panel next to end wall. Plumb both panels and join by nailing with 16-penny nails. Tilt up and install opposite side wall panel and connect to end wall. Continue by installing the remaining side panels and finally install the second end wall. Tighten all tie-down bolts and plumb the walls by using temporary braces.
- e. Lift trusses into place over end walls and over each principal stud of side walls. Nail trusses to top plates with 20-penny or toenailed 16-penny nails. Plumb all trusses and secure with temporary braces.
- f. Nail purlins to trusses with 20-penny nails or toenailed 16-penny nails. The structural frame is now complete. This is adequate to support lightweight roof and wall covering systems. If heavy wall and roof systems are used, the number of principal studs and roof trusses should be doubled and spacings for these elements should be halved.

**Step 6. Installation of roof cladding**

Any of a variety of roof covering materials could now be installed. A typical system is composed of corrugated cement-asbestos panels, each 5 feet long. These are placed with end laps of 8 inches and side laps of 1 corrugation (corrugated metal requires side laps of 1-1/2 corrugations). Each panel is nailed through the crown at every fourth corrugation with 12-penny nails with washers of rubber, impregnated felt, or lead. Some types of panels require drilling before nailing.

**Step 7. Installation of wall sheathing**

The side and end walls can be covered with any appropriate cladding material, with shutters or louvers, with curtains or with screening which will admit air but keep out insects and other intruders. One suggested method for enclosing walls is shown in the drawing. This shows fixed louvers of flat boards or sheet metal held at a 35-degree angle from the studs by wood blocks. The lowest 6 inches of the wall is covered with flat siding material, the upper 30 inches is screened only, and the rest of the wall height is covered with screening and the louver arrangement.

**Step 8.** Screen doors with storm covers are recommended for the end walls. A canopy over each door will help protect against sun and rain. Electrical lighting facilities and ventilating fans may be placed as desired.

## USE OF SALVAGE LUMBER IN BUILDING CONSTRUCTIONS

Many pieces of miscellaneous lumber from packing cases, demolished buildings, and scrap piles can be joined to form structural members of laminated, spliced, or trussed form. The final structural member may turn out to be larger and less handsome than a similar member of new material and may require extra labor of fabrication but it can be made to perform as an adequate component of a structure. Built-up members can most easily be joined by nailing, perhaps assisted by gluing, and certain members could be assembled with screws or bolts.

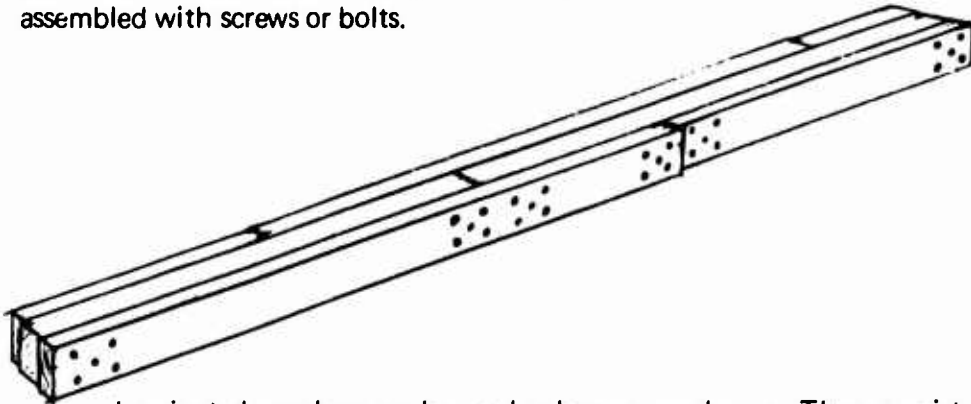

Laminated members can be used as beams or columns. They consist of two or more layers of wood assembled longitudinally along the axis of the member; with the short pieces butting end-to-end; and with all butt joints staggered. Nailing should be with nails long enough to penetrate all layers of the lamination and with sufficient number of nails (4 to 6) to develop shear strength of the butt joints.

Spliced members are constructed in somewhat the same manner as the laminated members except that the augmented thickness of the member occurs only where two principal parts are joined end-to-end. Splices should not be made at the unsupported middle of built-up beams or columns, since that is the point of greatest bending stress. Splices should preferably be at points near enough to the ends of the members so that diagonal braces could be installed to assist in support. Splices consist of short lengths of wood (scabs) nailed on at least two sides, and preferably four sides, of the butt joint. Each joint should be nailed so that adequate shear strength is developed (10 to 12 nails in each scab).

Trusses are merely a succession of triangles joined together. Each triangle becomes a truss panel and the three sides of the panel carry principally compressive or tensile forces. Short pieces can be readily joined in trusses to form efficient structural members. Trusses can be shaped to carry sloped roofs or can be formed to act as structural walls of a building. Trusses could be fastened with a single bolt at each joint or could be tied at the joints with nails (4 to 6, long enough to penetrate every member of the joint).

The use of scrap lumber in forming secondary structural members of short length such as braces, brackets, purlins, girts, etc. offers no special problems. Short pieces may also be used in the construction of accessories such as louvers, shutters, doors, etc. Here batten construction might be of value.

## ROOF AND WALL CLADDING

Coverings of light frame structures may be of a wide variety of materials. The prime purpose of the coverings is to keep out wind and rain; therefore, materials and installation methods should be selected to resist those elements. Covering materials are in order of preference: corrugated or flat galvanized steel, aluminum, asbestos-cement or plastic panels; plywood or wood boards; "wet shingles";\* cement stucco; wood or composition shingles; plastic, canvas or impregnated felt or paper sheeting; grass or leaf thatch or other vegetation.

Most coverings do not span much distance and are usually rested upon or attached to secondary supporting elements such as purlins in roofs and girts or laths in walls. Corrugated sheets are stiff in one direction and can span several feet in that direction if no unusual loadings are imposed. Coverings should be fastened to resist imposed loads, which may be of the pressure or suction types.

### Panel Coverings and Claddings

Panels or sheets of metal, asbestos-cement and plastic are easy to install and have adequate resistance to the weather. They should not be used on roof slopes less than 4 inches in 12. Such panels are usually fastened by nailing at 8- to 12-inch intervals (every fourth corrugation). Corrugated panels are nailed through the crown with 8-penny nails with soft washers; flat panels require roofing nails and soft washers. Flat sheets are often prefabricated with wood frames to metal panels. Metal panels can be nailed through punched holes but most asbestos-cement and some plastic panels are brittle and require drilled holes. End laps of 6 to 8 inches on roofs and 4 inches on walls with side laps of 4 inches (1-1/2 corrugations for metal and 1 corrugation for asbestos-cement panels) are usual. Mastic applications at end and side laps are recommended. At the eaves, panels should project 3 inches beyond their supports. Ridge angles or ridge rolls of similar material should be used at roof peaks.

---

\* Described on page 37.

It is advisable to start application of the sheets at the end of the roof in the opposite direction to prevailing winds to insure that wind and rain will blow over the laps, not into them.

### **Steel Sheeting**

This usually is galvanized and corrugated. The panels are most commonly of 26-gage metal, 26 inches wide and 8 feet long. Galvanized sheet steel can be used in direct contact with most woods, with concrete, mortar, lead, tin, or zinc. With other materials it should be coated with asphalt-type paint to prevent corrosion. If used with redwood or red cedar, the metal should be coated. If white surfaces are preferred because of their reflective properties, galvanized steel can be painted after a priming coat of calcium plumbate.

### **Aluminum Sheeting**

Aluminum sheets will reflect about 60% of the sun's radiation. The remainder of the sun's heat is conducted to the underside of the aluminum sheet which becomes warm and radiates to the interior spaces. Aluminum is noncombustible and satisfactorily resists fire penetration and surface spread of flame. Corrugated aluminum roofing sheets are self-supporting and are capable of spanning distances of several feet without intermediate support.

Aluminum sheets should be fastened with aluminum nails; steel or copper nails will cause corrosion. Aluminum should not be used in contact with moist building materials or the ground.

### **Asbestos—Cement Panels**

Asbestos—cement panels are relatively cheap and can be shaped with little difficulty. They are used for roof and wall cladding. In the usual practice, the panels are corrugated. The material is not readily attacked chemically or by insects. The asbestos fibers are normally from 1/4 inch to 2 inches in length. A combination of long and short fibers is generally used. The relative proportions of asbestos fiber and cement mortar used are approximately 1:8 by weight of fiber to cement mortar. If asbestos cement panels are painted this should be done on both sides of the panel in order to reduce uneven moisture absorption and the possibility of cracking.

The thickness of asbestos—cement panels is approximately 1/4 inch for sheets of 4 x 8-foot size. The material is brittle and holes for attachment should be drilled rather than punched. The sheets should be so attached that some movement of the sheets can occur. The attaching nails (8 or 10 penny) or other hardware should never be nearer than 1-1/2 inches from the edge of a sheet and should be fastened through the crown of corrugations.

The maximum permissible purlin spacing for asbestos—cement sheets is 3 or 4 feet. The recommended minimum pitch of roof for asbestos—cement corrugated sheets is 3 inches in 12.

### **Plastic Panels**

Plastic sheets in flat or corrugated form come in a variety of formulations and patterns. Most such materials are sensitive to temperature and to effects of loading. Most commonly used in building construction are sheets of acrylic or glass-reinforced polyester. Plastic sheets in corrugated form follow the same patterns as do metal or asbestos—cement panels; the accessories for attaching the panels to each other are usually interchangeable. Plastic sheets are usually 1/16 to 1/8 inch thick. A corrugated sheet can span from 2-1/2 to 4 feet with a 100-pound load.

### **Plywood Panels**

For roofing and siding use plywood should be of exterior grade. This means that the glue used between the plies is of phenol resin or other water-resistant material. Interior plywood will come apart in the presence of excess moisture. Plywood normally comes in 4 x 8-foot sheets. Thicknesses range from 1/4 inch to 1 inch. Plywood is quickly installed by nailing directly to main framing members with 4-penny or 6-penny nails. Space nails at 1-foot centers around the edges and to any backup supports inside the panel. Edges of adjoining panels are butted together and the joints are sealed with mastic or soft gaskets secured with batten strips. Plywood panels will normally form a watertight roof at a slope of 1 to 3 or better. For flat or low-sloped roofs additional coverings of impregnated felt or building paper are recommended.

### **Wood Boards**

Sheathing boards usually are of 3/4-inch or 1-inch nominal thickness, 6-inch, 8-inch, or 10-inch width and come in lengths up to 16 feet. Usually joints are tongue-and-groove, ship-lap, or similarly fitted. For best resistance to water infiltration the boards should be laid with the slope of the roof or be placed vertically in walls. Batten strips with mastic or white lead can be

used at the joints to improve watertightness. If boards are placed horizontally, the overlapping part of the joint should be placed to conduct water past the joint. Boards are nailed with 8-penny nails (2 nails to each cross-piece). End joints of succeeding courses of boards should be staggered. For slopes of less than 1 to 3, additional roof coverings of impregnated felt or building paper should be used. For sidings in warm climates the boards can be tilted outward at the bottoms to form louvers which will admit air but keep out rain.

### Wet Shingles

"Wet shingles" can be used for exterior coverings of walls and steep roofs. Basically a wet shingle is a burlap bag or other fabric or vegetation sheet which is impregnated with cement mortar by complete immersion in a sand-cement slurry. While still wet, the mortar-impregnated sheet is nailed to girts or purlins and allowed to drape naturally. Successive courses of these wet shingles are applied with overlaps of about 4 inches. At points of overlap the uppermost sheet is pressed to join with the bottommost sheet, thus forming a monolithic wall panel after hardening. It is recommended that the individual wet shingles be not more than 4 feet in horizontal dimension and approximately 18 inches in vertical dimension.



The cement slurry in which the bags or sheets are dipped is made of 3 parts sand to 1 part portland cement. The water content should be controlled to permit adequate impregnation, but the slurry should be relatively stiff. Girts or purlins could be 1 x 4-inch boards or 2 x 2-inch timber members; these should be spaced horizontally at approximately 14-inch centers. When wet shingles are applied to sloping roofs, the slope should not be less than 1 in 4. The shingles can be rendered or plastered after they have dried, but this process is usually not necessary since the draped wet shingle usually has a thickness of 1/2 to 3/4 inch. The wet shingles should be periodically covered with a light water spray during the curing phase to prevent cracking.

## **Stucco**

Stucco is used for walls but is not normally applied as a roof surface. A mortar mix of 1 part portland cement and 3 parts sand is applied with a trowel to a lath of wire or narrow wood strips. A layer of building paper between the supporting frame and the lath is recommended. The stucco is usually applied in two coats to form a thickness of 3/4 to 1 inch.

## **Wood or Composition Shingles**

Shingles are nailed to solid or spaced wood sheathing boards with large-headed 3-penny to 6-penny shingle nails. Wood shingles come in random widths and can be from 16 to 27 inches long. For roofs of 1 to 3 pitch, about 1/4 of the length is left exposed to weather, while steep roofs can expose about 1/3 of the shingle. Siding shingles expose about 1/2 length to weather. Composition shingles usually expose about 1/2 length to weather for both roofs and sidings. Side joints in shingle construction should be staggered in successive courses.

## **Fabric or Plastic Sheeting**

Large roof or wall surfaces can be quickly covered with woven canvas or nylon sheeting or with film sheets of plastic such as polyethylene or polypropylene. Such materials are subject to shrinkage or stretching due to moisture, temperature or applied loadings. It is best if connections to supporting frames be of the laced or lashing types rather than permanent connections of bolts or nails. The material should be fastened around all edges and internal tiedowns used when possible. Removable batten strips can be used as edge and intermediate fastenings. Flexible sheeting can be used on fairly low-sloped roofs if precautions are taken to interfold edges where joints occur. The service life of such coverings is liable to be quite short and the material should not be relied upon for more than a few months of service.

## **Vegetation Covering**

Some people have been covering their houses with vegetation for ages. The details of such construction are probably best left to them. Vegetation coverings need frameworks for attachment which are usually gridworks of bamboo or small branches. The frameworks are joined by lashings and the vegetation is attached by similar lashings. Tufts of grass or leaves are laid down in overlapping fashion and sometimes battens of bamboo or branches are used to secure the covering in place. Walls are most easily covered with woven mats of vegetation, lashed to the framework. Such coverings are subject to quick deterioration and infestation and should not be expected to last for more than a few months.

## BAMBOO CONSTRUCTION

Bamboo is a useful primary, secondary, or occasional source of building material. Bamboo culms (canes), the natural units of the plant, are a size and shape that make handling, storing, and processing convenient and economical. The canes have a high strength-weight ratio and can be easily divided by hand into short pieces by sawing or chopping, or into narrow strips by splitting.

House framing members can be of bamboo. The elements correspond closely to those found in all timber framing; corner posts, girders, plates, joists studs, struct or braces, beams, purlins, ridgepoles, rafters, sheathing, and so forth. Care must be taken with the joints of bamboo frames; cuts into the material drastically reduce the strength. Since nailing often results in splitting of the bamboo, it is preferred to tie the members together with appropriate lashings; galvanized soft steel wire is often used. Since bamboo is more resilient than conventional timber, space between supports should be reduced accordingly.

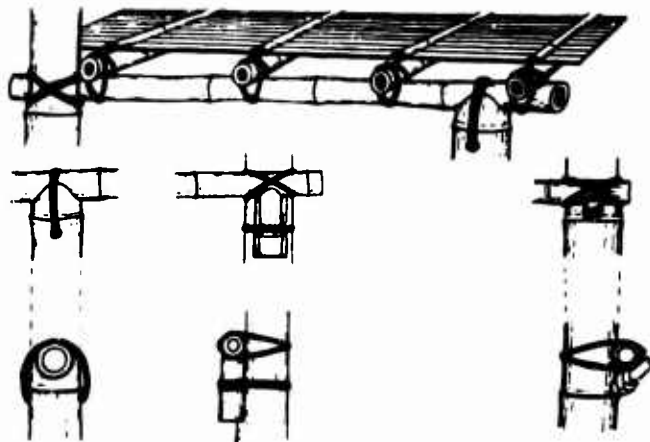
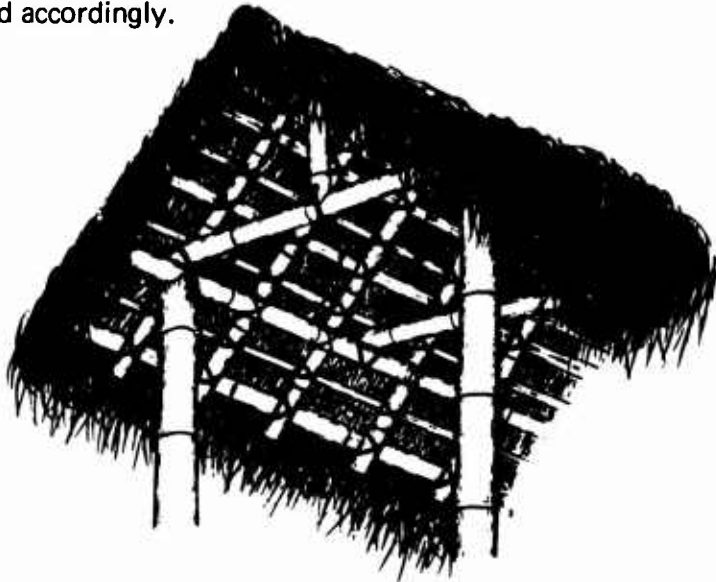

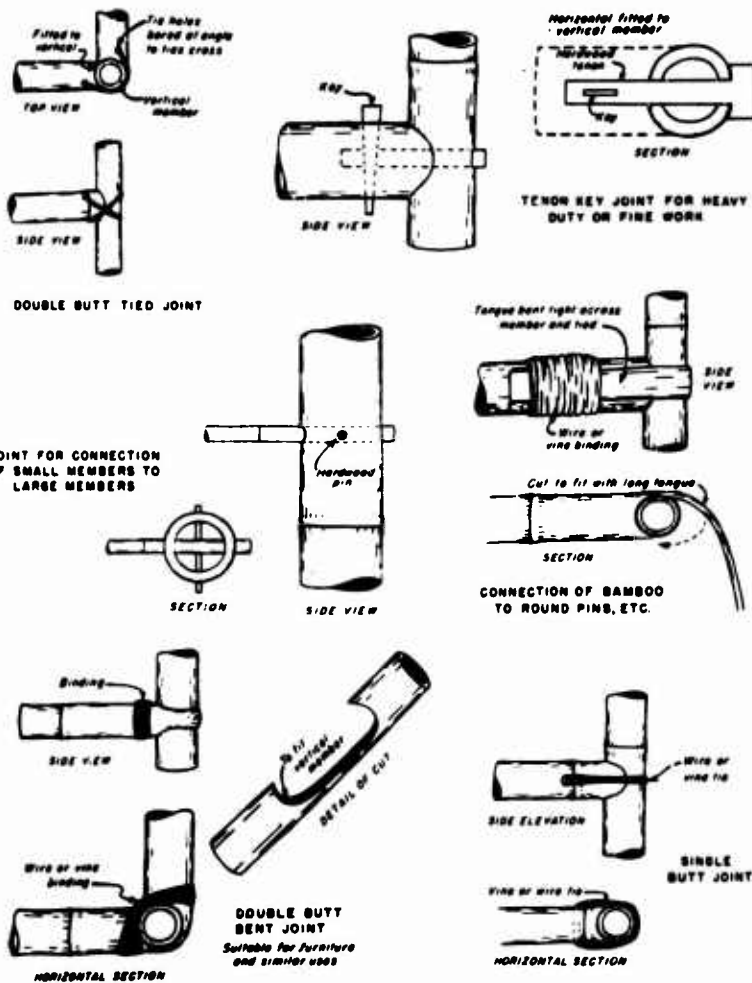

Bamboo can be used for walls, floors, room dividers, roof frames, and roof sheathing, but is not recommended for foundation posts.

Bamboo walls are made in many varieties. Either whole canes or half canes can be used and these can be applied in either horizontal or vertical array. Sometimes space between bamboo strips is filled with mud or plaster.

When bamboo is used for flooring, it is recommended that the canes be laid down before the earth floor is compacted. When the floor is compacted, the bamboo is brought into close contact with the earth and an even surface is obtained.

For use as screens or room dividers, bamboo mats can be prewoven and then attached to frames. Mats can be used in much the same way to form wall curtains.

Roof frames of bamboo can be used to excellent advantage if the nature of the roof covering is taken into consideration. The roof sheathing should be lightweight thatch, halved bamboo canes, bamboo shingles, corrugated sheet metal, or asbestos-cement sheets.

Most types of bamboo are attacked by wood-eating insects and by dry rot. To season bamboo:

1. Sever each cane at base but keep upright position in clump.
2. Dust the fresh cut lower end by patting it with a dusting bag filled with a 1 to 20 mixture of DDT and talc.
3. Raise canes off the ground and place on blocks to prevent deterioration by fungi. Permit the canes to remain from 4 to 8 weeks to thoroughly dry. After drying, dust all the surfaces with a 1 to 20 mixture of DDT and talc. Do not store seasoned bamboo in the open, where it is exposed to moisture.

### TERMITE PROOFING

Wooden materials in the tropics are subject to accelerated failure as a result of early and intense attack by termites. The following measures will prolong the life of wooden structures considerably.

1. Clear the site thoroughly and remove all woody material.
2. Avoid accumulation of moisture by selecting well-drained sites or providing drainage, by providing ventilation, and by raising the structure on piers rather than on slabs.
3. Use mechanical barriers (metal caps or concrete courses) and have the bottom of floor supports at least 18 inches above the soil.
4. Poison the soil to make a chemical barrier to termites. Use 4 to 8 gal/100 ft<sup>2</sup> of 5% pentachlorophenol in fuel oil or water emulsion or 10 gal/100 ft<sup>2</sup> of 0.3% dieldrin as a water emulsion. Sodium arsenite in a 10% solution in water at a rate of 12 to 20 gal/100 ft<sup>2</sup> can also be used.
5. Use local timber naturally resistant to termites, or treated timbers.
6. Avoid cracks in foundations, penetration of wooden members below the supporting piers, and additions to the structure which would serve as a soil-to-structure bridge for the termite.

If concrete slabs are used they should provide a continuous apron at least 6 inches wide around the structure. Termite tunnels crossing the slabs from the surrounding soil can then be readily observed. Termite-proofing concrete with dieldrin is recommended. Mix the concrete with water containing 0.5% by weight dieldrin (2-1/2 pounds of 20% emulsifiable concentrate in 10 gallons of water).

## BIBLIOGRAPHY

Agency for International Development. Leader training for aided self-help housing, by K. H. Hinchcliff. Washington, D. C., 1963.

Building Research Station. Colonial Building Notes, no. 2 through 50, Sept. 1950—Apr. 1958. Garston, Watford, Hertfordshire, England.

———. Overseas Building Notes, no. 51 through 126, May 1958—Sept. 1968. Garston, Watford, Hertfordshire, England.

Housing and Home Finance Agency. Office of International Housing. Ideas and methods exchange no. 18: Aided self-help in housing improvement, Rev. ed. Washington, D. C., 1961.

———. Ideas and methods exchange no. 58: "Colonia Managua," an aided self-help housing project in Nicaragua. Washington, D. C., 1962.

———. Ideas and methods exchange no. 37: Manual on design of low-cost and aided self-help housing, Rev. ed. Washington, D. C., 1961.

———. Ideas and methods exchange no. 55: Organization of individual aided self-help housing projects in Puerto Rico. Washington, D. C., 1961.

Inter-American Housing and Planning Center. Self-help housing guide. Bogota, Columbia, 1962. (Design and construction series)

Naval Civil Engineering Laboratory. Technical Note N-808: Bamboo reinforced concrete construction, by F. E. Brink and P. J. Rush. Port Hueneme, Calif., Feb. 1966.

———. Technical Report R-357: Developments in protective shelter systems, by P. J. Rush. Port Hueneme, Calif., Apr. 1965. (AD 614979)

———. Technical Note N-466, Addendum: Summary of data concerning preengineered buildings, by P. J. Rush, R. L. George, and D. S. Harrington. Port Hueneme, Calif., Oct. 1966. OUO

———. Technical Note N-466: Summary of NCEL reports on pre-engineered buildings, by W. Q. Ginn. Port Hueneme, Calif., Feb. 1963. (AD 297844)

———. Technical Note N-981: Survey of buildings of prefabricated, expandable, inflatable, or chemically-rigidized types suitable for military use, by P. J. Rush. Port Hueneme, Calif., Aug. 1968. (AD 839339L)

Proceedings of the World Planning and Housing Congress, held at San Juan, Puerto Rico, 28 May—3 June 1960. San Juan, Puerto Rico, Department of Education Press, 1961. (Available from: Inter-American Planning Society, P.O. Box 1729, San Juan, Puerto Rico)

United Nations. Department of Economic and Social Affairs. Publication no. ST/SOA/53: Manual on self-help housing. New York, 1964.

Unclassified

Security Classification

DOCUMENT CONTROL DATA - R & D		
<i>(Security classification of title, body of abstract and indexing annotation must be entered when the overall report is classified)</i>		
1. ORIGINATING ACTIVITY (Corporate author) <b>Naval Civil Engineering Laboratory Port Hueneme, California 93041</b>		2a. REPORT SECURITY CLASSIFICATION <b>Unclassified</b>
		2b. GROUP
3. REPORT TITLE <b>HOUSING FOR RVN REFUGEES</b>		
4. DESCRIPTIVE NOTES (Type of report and inclusive dates) <b>Final; August 1968—October 1968</b>		
5. AUTHOR(S) (First name, middle initial, last name) <b>P. J. Rush</b>		
6. REPORT DATE <b>October 1969</b>	7a. TOTAL NO. OF PAGES <b>44</b>	7b. NO. OF REFS <b>15</b>
8a. CONTRACT OR GRANT NO.	8b. ORIGINATOR'S REPORT NUMBER(S) <b>TR-644</b>	
b. PROJECT NO. <b>YF 38.536.006.01.003</b>		
c.	8d. OTHER REPORT NO(S) (Any other numbers that may be assigned this report)	
d.		
10. DISTRIBUTION STATEMENT <b>This document has been approved for public release and sale; its distribution is unlimited.</b>		
11. SUPPLEMENTARY NOTES		12. SPONSORING MILITARY ACTIVITY <b>Naval Facilities Engineering Command Washington, D. C.</b>
13. ABSTRACT <b>This report is intended as a manual for use by U. S. military advisors engaged in the supervision and construction of housing for refugee native populations in the Republic of Vietnam. Use of indigenous materials, manpower, and methods in self-help operations is presumed. Examples of primitive construction are shown. Problems of site selection and preparation, building functionality, and habitability are discussed. The elements of buildings are presented, materials are explained, and construction methods are proposed.</b>		

14 KEY WORDS	LINK A		LINK B		LINK C	
	ROLE	WT	ROLE	WT	ROLE	WT
Vietnam refugee housing Construction materials Construction techniques Site selection Site preparation						