

2892690



TM-2304/108/00



ON-LINE COMPUTER STUDIES OF BARGAINING AND NEGOTIATION BEHAVIOR:
FINAL REPORT FOR CONTRACT DAHC15-67-C-0277, ARPA ORDER NO. 637/2

This research was supported by the Advanced Research
Projects Agency (Behavioral Sciences), under Contract
DAHC15-67-C-0277, ARPA Order No. 637/2.

Reproduced by the
CLEARINGHOUSE
for Federal Scientific & Technical
Information Springfield Va. 22151

DDC
RECEIVED
DEC 4 1969
RECEIVED
B

September 1969

This document has been approved
for public release and sale; its
distribution is unlimited

112

TECHNICAL MEMORANDUM

(TM Series)

Distribution of this document is unlimited.

ON-LINE COMPUTER STUDIES OF BARGAINING AND
NEGOTIATION BEHAVIOR: FINAL REPORT FOR CONTRACT
DAHC15-67-C-0277, ARPA ORDER NO. 637/2

By

G. H. Shure and R. J. Meeker

September 1969

SYSTEM
DEVELOPMENT
CORPORATION
2500 COLORADO AVE.
SANTA MONICA
CALIFORNIA
90406

This research was supported by the Advanced
Research Projects Agency (Behavioral Sciences),
under Contract DAHC15-67-C-0277, ARPA Order
No. 637/2.



The views, conclusions, or recommendations
expressed in this document do not necessarily
reflect the official views or policies of
agencies of the United States Government.

ABSTRACT

This is the eighth and final Report for the On-Line Computer Studies of Bargaining and Negotiation Behavior Project. This report describes the progress on SDC's contract DAHC15-67-C-0277 with the Advanced Research Projects Agency of the Department of Defense, which has been under way since July 1, 1967.

This research program was designed to lead to a set of empirically derived propositions on bargaining and conflict resolution behavior, and on processes that occur in situations where the parties involved have both common and conflicting interests--that is, where they are mutually dependent in the pursuit of otherwise antagonistic goals. Of particular concern were those issues and strategies in bargaining that appear to be relevant, actually or potentially, in political-military confrontations, particularly limited conflicts.

This program involved five routes of development, and particularly the interaction and mutual support among them.

1. The design and use of international simulation methodology--both manual and computer-based--for studies of IR theory and policy issues. The effort in this area was a distinct departure from our previous work but a logical extension of it--of computer and research methodologies to complex, multi-person, international relations games. We attempted to break through some of the methodological limitations that currently threaten the viability of such games for use as tools in both theory-building and policy study.
2. The development of software support for the computer-based laboratory.
3. The development of computer systems for data management and analysis.
4. On-line computer experiments in bargaining and negotiation.
5. Design and plans for a new ARPA supported Center for Computer-based Behavioral Studies.

This final report, covering a period of two years, reviews the progress of this work.

TABLE OF CONTENTS

	<u>Page</u>
I. DESCRIPTION OF PROJECT	3
II. PROGRESS	9
A. LABORATORY SIMULATION	9
1. Background	9
2. Simulation Development	16
3. Framework for Subsequent Simulation Studies	24
B. DATA MANAGEMENT AND ANALYSIS SYSTEMS	37
1. The TRACE Data Management System	37
2. Inductive Data Analysis	46
C. COMPUTER-BASED LABORATORY--SOFTWARE AND FACILITY DEVELOPMENT	51
1. Computer-Based Laboratory Facility	51
2. Computer-Based Laboratory Software	54
D. ON-LINE USE OF EXPERIMENTAL AND NON-LABORATORY TECHNIQUES	66
1. On-Line Computer Experiments in Bargaining and Negotiation Processes	66
2. SCENQUEST--A Scenario Questionnaire Technique for Studying In-Process Phenomena in Conflict Resolution	88
3. The Development of a Propositional Inventory of Attributes of American Character That May Influence American International Diplomacy and Negotiations	90

	<u>Page</u>
E. PLANS FOR A COMPUTER-BASED CENTER FOR BEHAVIORAL STUDIES	91
PROJECT DOCUMENTATION	94
PROFESSIONAL AND PROJECT-RELATED ACTIVITIES	98

I. DESCRIPTION OF PROJECT

Conflict resolution is not monolithic and is not susceptible to any single research approach. The conditions of conflict and processes of resolution can be more or less abstracted, variously represented, and studied by a number of methods. The fragmentation that results from many specialized studies can be overcome to some extent by a program that encompasses and interrelates many different levels and techniques of investigation. This report describes a program that ranges widely, and in many dimensions: in content, from highly abstracted simple games to a representation of the international system; in method, from paper-and-pencil situations to the most elaborate computerized laboratory settings; in participants, from the college sophomore through experienced specialists in conflict resolution; and in focus, from evaluation of tactics and strategies to examination of bargainer's personalities and attitudes. The capabilities for this program--including the associated techniques for data management and analysis--have evolved from an ongoing research effort on bargaining and negotiation behavior.

Our research program is designed to lead to a set of empirically derived propositions on bargaining and conflict resolution behavior, and processes that occur in situations where the parties involved have both common and conflicting interests; that is, where they are mutually dependent in the pursuit of otherwise antagonistic goals. The basic situation is one in which the participants have mixed motives toward one another. It is neither purely

coordinative or cooperative, nor purely competitive. The ability of one participant to gain his ends is dependent to an important degree on the choices or decisions of the other participant. The intention of the research is not to reproduce all important dimensions of such situations, but rather to identify features of a problem that are open to research, and that appear to reflect issues of general significance. Of particular concern are those issues and strategies in bargaining that appear to be relevant, actually or potentially, in political-military confrontations, particularly limited conflicts. In such situations, bargainers frequently employ tacit means of communication, proceeding as much through actions and maneuvers as through direct exchange of explicit communiques; they are able to impede one another, and to inflict loss or harm on the other party; they are frequently unclear about the values and power of the other party. Under such conditions, which breed mutual distrust, how can negotiators succeed in mutually influencing one another to contain or resolve their conflict? What are the characteristics of the exchange of moves and signals that lead to unilateral advantages or successful joint resolution? If limited wars imply limited victories--and sometimes limited defeats--are the factors that break the implicit limits and lead to conflict escalation identifiable? Can the properties of the bargaining context, or characteristics of the parties in the conflict, be identified as critical influences on the resolution process?

General techniques have been developed for empirical study and analysis of the sequential exchange of moves and countermoves occurring in the bargaining process. Central to the development of our research methodology is the concept of the computer-based laboratory. Three distinct uses made of the computer in this context are the following.

1. Computer-administered experiment. This laboratory configuration of interactive consoles tied to a computer permits us to use the computer as an experimental tool for on-line presentation of the bargaining situations to the subjects. Through computer programs, subjects are paired against one another or against simulated players. Each subject sends his action (messages, moves, bids, threats, offers, etc.) via the interactive console keyboard to his adversaries, who receive the action on their console display surfaces. All such actions are routed through the computer. In this way the computer programs can administer the experiment--umpiring the legality of moves, providing displays of game-relevant information, and recording all moves, messages, and times.

2. Computer-controlled, in-play questioning to augment multiple inquiry data. The answers to many questions on bargaining behavior can be found in the detailed process data of moves and countermoves and in the in-play subject reports that reveal how negotiators shift their evaluation of outcomes, alter their goals, and attempt to induce their opponents to alter theirs. A complete analysis of bargaining requires not only data on the overt pattern and sequence

of verbal exchanges, moves, and countermoves, but also requires a parallel assessment of the bargainers' changing intentions, expectations, and perceptions of relative status and opponent behavior. We must obtain data on the temporal unfolding of moves and on associated shifts in player perception that indicate what the bargainer intends to do, believes he is doing, plans to do--and why.

In addition to administering the experiment, the computer is programmed to aid in the assessment of game moves by collecting associated subjective data at critical points during the bargaining process itself. Between game messages and moves, or between trials, the computer, through displayed questions, asks the subject to rate or rank various bases of his actions, his current intentions and expectations, his perception of his opponent; or, through subtle or disguised items, indirectly elicits the subject's attitudes about the bargaining situation. Thus, an important type of behavioral data that is otherwise practically unobtainable is gathered, together with the more detailed process data. This enables the investigator to identify and pinpoint the dynamics of the bargaining process both at the individual level (the reasons and motivations behind certain actions) and at the interpersonal level (action-reaction effects).

3. Data management and analysis. If computer experiments of the kind described are conducted "on-line," the amount of data the system is capable of collecting can become impossibly large. If these data are hierarchical, sequence ordered, and of variable length (all conditions found in our experiments), then the problem of data management becomes overwhelming, particularly that aspect of it that attempts to identify and classify configurations of moves and to map

stage-by-stage changes in patterns of use. For the collected data to be of maximal inductive value, new techniques and analysis, such as TRACE, IDEA, and BINAL, were developed to cope with problems of data scanning, reduction, and analysis.

In summary, we have developed general methodological capabilities--the control and data gathering functions provided by the computer administered experiment, the important amplifying data provided by the on-line interviews, the data handling and the inductive assistance provided by TRACE and IDEA-- that can be turned to focus on almost any aspect of bargaining and negotiation behavior.

Work undertaken previously was continued and extended during the two-year period covered by this contract. This report describes the progress on five major lines of research and development activity; and the interaction and mutual support among them.

1. The design and use of international simulation methodology--both manual and computer-based--for studies of IR theory and policy issues. The effort in this area was a distinct departure from our previous work but a logical extension of it--of computer and research methodologies to complex, multi-person, international relations games. We attempted to break through some of the methodological limitations that currently threaten the viability of such games for use as tools in both theory-building and policy study.

2. The development of software support for the computer-based laboratory.

3. The development of computer systems for data management and analysis.
4. On-line computer experiments in bargaining and negotiation.
5. Design and plans for a new ARPA supported Center for Computer-based

Behavioral Studies.

The reports for each area of activity vary in length depending on the extensiveness of previous reports and publications and the completeness of current analyses.

II. PROGRESS

A. LABORATORY SIMULATION

1. Background.

Laboratory gaming and simulation are being used increasingly for research in many fields of social behavior, both for theory building and for exploring practical questions of policy and planning. But the validity and usefulness of such complex simulations are open to serious question because of certain fundamental limitations. These are particularly noticeable where the world created in the laboratory attempts to simulate complex aspects of social reality; paradoxically, it is in these studies that the laboratory gaming approach is still considered, potentially, most useful. Thus the promise of simulation remains attractive even though there is an increasing awareness that it has been largely unfulfilled (Meeker and Shure, 1968).¹

Behind the acceptance of this state of affairs is the almost axiomatic assumption that rigorous research and realism are inversely related. Complexity tends to be sacrificed to evaluation, or research goals abandoned for the sake of realism; thus, it appears that those drawn by the potentials of simulation must ultimately choose between the richness of validity and the constraints of tractability for analysis. To imply that the choice of the laboratory study narrows to an unwieldy verisimilitude or a sterile precision would be, of course, an overstatement; the distinctions are not that gross and the choice is rarely explicit, but there is undoubtedly a general polarization that tends to dichotomize gaming research into two camps.

¹ Papers completed during the two-year period of the project are listed under Project Documentation and cited in the body of the document by author and year of publication. When earlier works by the authors or other references are cited, they are shown in footnotes at the bottom of the page.

For example, the International Simulation (INS) Game, one of the major examples of simulation for theory building, attempts to abstract critical system variables of the international scene and to model their interaction. It emphasizes operational definition and, where possible, the quantification of variables and the systematic recording of data. Replication of runs is used to demonstrate the stability of results obtained. In this game, players, generally students, take the roles of the leaders of interacting, hypothetical countries. INS games attempt to test a set of preformulated hypotheses taken from the political science literature.²

INS has been criticized on a number of grounds, a few of which are: the questionable significance of the system variables selected and the representation of their relationships; the omission of critical situational factors that operate in the real world (such as historical and geographical constraints); the use of naive, inexperienced players, driven perhaps by inappropriate motivation; and the unrealistic manipulation of simulated events for experimental purposes.³ Although INS has evolved in considerable

2

H. Guetzkow, and others; Simulation in International Relations, (Englewood Cliffs, N. J.: Prentice-Hall, 1963).

3

In particular, the validity of interrelationships of programmed variables in the INS model has been criticized (see R. W. Chadwick; "An Empirical Test of Five Assumptions in an International Simulation, About National Political Systems", General Systems, XII (1967), 177-192; R. E. Pendley, and C. D. Elder; An Analysis of Officeholding in the International Simulation in Terms of Contemporary Political Theory and Data on the Stability of Regimes and Governments (unpublished manuscript, Northwestern University, 1966), and others; the unrealistic manipulation of simulated events in INS also has been criticized (see R. N. Rosencrance and J. E. Mueller; "Decision Making and the Quantitative Analysis of International Politics", London Year Book on World Affairs (1968); and H. A. DeWeerd; Political-Military Scenarios, paper presented at a conference on Modern Strategic Analysis, held by Security Studies Project of UCLA on January 13, 1967, available as RAND document P-3535).

measure from the contribution of social psychology research, its focus has remained primarily on the representation of features of the international system and theory in the laboratory simulate (i.e., external validity). Little effort has been devoted to problems of internal validity. Thus one finds an almost complete neglect in evaluating the perceived significance of the simulate for the players, their success or failure in role playing, their perceived adequacy in facing the conceptual demands of the situation, the extent to which a serious or "game playing" atmosphere was adopted, etc. Because of these shortcomings, INS has not received serious consideration by professional policy makers or advisers, either for theory building or as a basis for policy guidance.

Policy-oriented games, such as those conducted at RAND, M.I.T., and the Joint War Games Agency, attempt to avoid such pitfalls. Rather than being general, they tend to be intensive single-case studies of likely situations close to reality and involving real countries, as perceived by experts. Policy-oriented games typically use realistic political-military-geographical settings; they use seasoned, professional military and political experts as decision makers; they give attention to a wide range of relevant historical and current events; they use realistic action scenarios--the product of expert judgment--to guide the game; and they require players to prepare national position papers, reviewed by a control team of experts who also manipulate the game in a way judged to be realistic for the simulated situation.⁴

⁴H. Goldhamer and H. Speier; "Some Observations on Political Gaming", Behavioral Science, 4, (1959), pp. 183-191.

In contrast to the INS example, the policy-oriented researcher is less concerned with testing theory than with gaining an understanding of decision making processes that occur during particular situations, and he does not typically attempt to subject his detailed data to systematic recording and analysis. Data implicit in the player's position papers, the umpiring decisions, the player's values, perceptions, motivations, etc., in conjunction with given moves and the progress of the game, are not objectively assessed. The methodologies employed also are typically unevaluated. (For example, the conviction that expert players, rather than naive ones, are needed to achieve validity in such complex games remains as much a matter of intuitive judgment as demonstrated fact.)

In summary, viewed from a research perspective, both the INS theory-building game and the RAND-type, policy-oriented game suffer from fundamental limitations that appear critical for their further development and validity as research procedures. Neither game produces sufficient explicit data to allow a detailed (micro) analysis of ongoing behavior processes that may be essential for understanding the step-by-step development of the game, the predicted molar relationships, and the final results. What has not been fully acknowledged by INS researchers is that when a simulation game reaches a certain point of complexity, it is no longer feasible to attempt to demonstrate patterns of cause and effect exclusively by extensive replications of runs. This is true not only because of the prohibitively high costs of replication, but because of the sizable interrun variability that may be anticipated for even the most carefully executed and controlled complex game.

Both the theory- and policy-oriented approaches have their respective strengths and weaknesses; to combine the assets of both requires a reformulation of the data collection and analysis problem. Where extensive replication, alone, is not a feasible means of establishing reliability and validity of results (and even where it is), we believe it necessary to augment the data collected in the standard simulation experiment by embedding them in an extensive matrix of fine-grain observations. Thus we suggest that the simulation investigator, whether theory-oriented or empirically-oriented, will find it not only desirable to collect more data than are required to test preformulated hypotheses, but that it is necessary for him to do so in order to properly amplify or clarify his understanding of his data. Particularly when anticipated relationships among variables fail to materialize (or, stated less elegantly, when predictions are not confirmed), he will wish to check various possibilities among supplementary data that may account for his negative results. As has been already demonstrated for simpler gaming studies,⁵ these details of response permit a more adequate reconstruction of the significance of the complex interplay of events and responses to these events. These systematically sampled data points allow a more adequate mapping of the micro processes and demonstration of patterns that underlie the predicted and unpredicted molar relationships.

⁵R. J. Meeker, and G. H. Shure; "Real-Time Computer Studies of Bargaining Behavior: The Effects of Threat Upon Bargaining," AFIPS Conference Proceedings, 1964 Spring Joint Computer Conference, pp. 115-123; and G. H. Shure, R. J. Meeker, and E. A. Hansford; "The Effectiveness of Pacifist Strategies in Bargaining Games," Journal of Conflict Resolution, 9, (1965), pp. 106-117.

Having stated these extensive demands for data collection, we also hold that in those simulations of social systems where human decision making behavior is a critical, if not a central, determinant of the performance of the system,⁶ it is not sufficient merely to record the overt actions taken; these data must be supplemented by the subjectively perceived significance of events and the decision maker's intentions. Elsewhere,⁷ we have attempted to characterize the decision making behavior under conditions where the problem situations develop piecemeal and spread out over time; and we have demonstrated the increased understanding of the decision process that is obtained if one can also obtain the immediately held, moment-to-moment perspective of the decision maker. While most individuals would be willing to grant the relevance of such data, the problem is to find an efficient means of obtaining these subjective data that permits us to establish the "presently actualized" perspective of decision makers. Where exercises or operations extend over any sizable period of time, and where a large number of events require decisions, the ability of the decision maker to reconstruct at a later time his original and altered assessments for even moderately complex situations is necessarily limited and is very likely to undergo modifications with the passage of time and changing configurations of circumstance.

⁶There obviously are many simulations in which the human participants are not of intrinsic interest, but are employed as an economic substitute for computer subprograms where the latter are too expensive or difficult to write; under these conditions, it is assumed the variation in the behavior of the human participants remains within acceptable bounds so that their performance does not distort the evaluation of other components or the system as a whole.

⁷G. H. Shure, and R. J. Meeker: "Probing Behind the Human Decision"; Proceedings of 15th Military Operations Research Symposia (MORS), (1965), pp. 35-39.

In an attempt to solve this problem, we use the speed and efficiency of the computer to collect, on-line, both actions taken and associated introspective data from decision makers as they are engaged in simulation experiments. In some studies the computer simultaneously monitors 24 participating subjects, detects all situations about which further information is desired, and then selectively (and with minimal disruption) displays questions relevant to what has just happened to each subject. The subject records his answer in a form the computer can store and interpret for subsequent analysis.

These procedures permit us to ask the decision maker what he is doing at times closer to the moments of critical significance for the decision; and as a result, these procedures considerably minimize loss and distortion of pertinent information that may reside only momentarily in the head of the decision maker. The difficulties of obtaining and interpreting these kinds of "subjective" data are necessarily very great and many problems of collection and interpretation remain unsolved. Nevertheless, the procedures have already yielded decisive information in a number of laboratory studies of negotiation processes.⁸

⁸ G. H. Shure, and others; Computer Studies of Bargaining Behavior: The Role of Threat in Bargaining, SDC document SP-2196 (February 1966), 172 pp. (contracted for publication with Academic Press).

2. Simulation development.

Work was undertaken along several lines that were designed to interact and converge toward the development of a simulation vehicle that satisfied our objectives--1) to surmount the major shortcomings and to combine the advantageous features of the general INS type of theory-building game and the RAND type policy-oriented game; and 2) where appropriate, to incorporate the type of data collection and micro analysis that has characterized our SDC bargaining studies. The lines of approach to be followed were to be the resultant of a number of considerations: the subject area context being modeled, and the hypotheses being tested; the selection of system variables; the structure of subsystem models; the constraints imposed by playability, data collection, and analysis. In sum, it was to reflect all the requirements imposed by the full set of goals for developing a significant research tool: develop computer simulation methodology; illuminate important policy questions of international relations; study issues in international systems theory and decision-making behavior in conflict-of-interest situations; and incorporate real world aggregate data and their interrelationships to specify variables in the simulation model. The fundamental work done with INS at Northwestern University was to serve as our starting point. We expected to profit by and to build on work already done toward establishing the external validity of variables as represented in INS and other games.

(1) Inter-Nation Simulation. A first step in this direction was to conduct a pilot manual run of INS at SDC during the month of July 1967. The primary purpose of this pilot run was to provide us with firsthand experience for evaluating the INS model and methodology as a basis for formulating our own computer-based simulation and laboratory model. The run was made under the direction of Professor Dorothy Meier using the INS model as she had modified it at Washington University. Graduate students served as participants (two per nation) and SDC staff and university faculty served as observers (one per nation) and as three overall directors. A program was written to run on the ARPA Q-32 computer to calculate the consequences of players' decisions. The latter were collected after each period and input to the computer via a teletype. Decision data were collected after each period on budgetary decisions, alliances, trades, communications, and conflicts. The simulation of the nine-nation system ran through six ninety-minute periods, each simulating one year. The experiment required six half-day sessions, including training and debriefing.

A series of critiques by participants and consultants who observed the run (Richard Brody of Stanford, Thomas Robinson and Harvey DeWeerd of RAND, Robert Noel of UCSB, and William Blanchard and Robert Brictson of SDC), led to a number of suggestions for improving the model: further differentiation of decision roles; modifications of various parts of the model (research and development, military, basic capabilities, internal validator

satisfaction index); re-evaluation of the emphasis on trade decisions; suggestions for the inclusion of relevant geographical features; a priority system for game communications; more time for preparation and evaluation of decisions; and the use of computer and other aids to help the decision-maker in routine calculations and in evaluation of alternative strategies. Of most importance, the run afforded a frame of reference for differentiating INS goals and procedures from those involved in gaming that also included a policy-relevance focus.

- (2) Choice of Substantive Content and Scenarios. Following the INS run, attention focused on the design of a new simulation vehicle. We believed that this could best be done with a specific research problem in mind--one in which a number of potentially relevant domains of variation for international political behavior could be examined.

For a number of reasons a problem in the general area of nuclear proliferation was chosen: (1) many members of the staff have worked on and around this problem area; (2) there is a rich, sophisticated, but unsettled literature on this topic; (3) the problems are by and large non-dyadic; (4) many domains of variation are articulated by the problem, e.g., global and systemic factors, national decision-making factors, national resource factors; (5) this problem area raises simultaneously questions involving motivation, assurances, alliances, conflict, power, bargaining, tacit boundaries, etc.; (6) a well-designed scenario on this

topic would be interesting to high-level participants; (7) a simulation vehicle designed for a specific study would be adaptable for other studies and other areas; (8) the problem area could lend itself to methodological variations (e.g., fictitious vs. actual nations, control teams vs. no control teams, different levels of participants, different numbers of nation-teams, and so forth); and (9) results could be contrasted with earlier INS studies that have focused on this topic.

Clearly, a great many potential studies exist in the nuclear proliferation area. We evaluated a number of alternative scenarios. In the process a number of questions were probed through discussion and the exchange of 50 internal working papers. Two scenarios were prepared which introduced changes in the regional and world situation by 1973 that would make a decision to opt for nuclear weapons a credible one for Israel and India. Both scenarios were subjected to criticism and analysis by staff members and area experts at RAND and UCLA. The Israeli scenario was pretested for playability; staff members prepared position papers and "first move" sequences for each nation involved; these were then cross-tabulated to determine the degree of intersection between the nations' policies and actions. This exercise provided general reassurance as to the scenario's playability and also suggested a need to provide a greater degree of policy structure, especially for less sophisticated subjects. Efforts then centered on procedures for facilitating players' comprehension and

assimilation of national policy positions.

- (3) Fact Book Development. Several drafts of a data archive "fact book" were developed for pilot runs of the simulation with student participants. Selection of substantive content was based upon: (1) review of quantitative research in international conflict behavior which highlighted those national characteristics related to foreign conflict behavior; (2) assessments of required, specific information for addressing the policy problem focused upon in a given pilot run; (3) estimates of the needs of specific types of game participants for information that would familiarize them with the variety and pertinence of available options. Fact book data have been estimated: (1) based on short-run projections of trends, in the case of economic characteristics of nations, and variables highly related to such characteristics (e.g., defense expenditures); and (2) based on the assumption that domestic conflict patterns in the nations simulated remain largely stable.

The format for presenting these materials was explored both from an "analog" viewpoint (how is information likely to be presented in real-world situations for real-world decision-makers?), and from the viewpoint of efficiency in a simulation (how can we effectively transmit information to players, given the laboratory capabilities at our disposal?). A format adopted for presenting these materials in the pilot runs was primarily through "thumbnail" sketches of nations participating in the

simulation. Content was ordered according to broad categories (such as economic, military, or political). Additional background information for non-expert participants (particularly on the range of situations and policy options) was provided by including a "scrapbook" section containing relevant historical material (Shure, et.al., 1968a).

Related to the construction of the data base, a document based on earlier work was completed (Chadwick, 1968). The document describes a causal model of the interaction between national and international behavior relevant to foreign conflict. In association with this effort, a program using a modified χ^2 method was written in Fortran IV to permit analysis of transaction flows in square matrices where normal procedures are inapplicable. This program was subsequently used in a study of the interaction and communication patterns among nations--in particular, patterns of diplomatic interaction. Data already collected on the diplomatic links of 107 nations in 1962-63 were analyzed with the rank of the country measured along economic and military dimensions as one independent variable (McRae, 1969).

- (4) Supplementary Data Gathering Instruments. In addition to the data represented by participant actions, communications and face-to-face deliberations within teams, a number of procedures were developed to aid in the collection and analysis of the policies generated. In particular, we attempted to analyze the steps by which staff advice and policies were translated into game moves. Forms and procedures were developed to assess preplay attitudes and goal

perceptions, personal styles of decision-making, individual and group planning developed in the course of play, national perception of power positions of the moves made, postgame attitudes of involvement and participation, etc. An evaluation of the obtrusiveness and usefulness of these instruments was a primary focus in the manual check out runs.

- (5) Manual Check Out Simulation. In June 1968, a check out run was conducted with 25 college newspaper editors as game players. These subjects participated as the policy advisors of six nations or nation complexes (Israeli; Egypt; U.S.A.; U.S.S.R.; a team representing non-Egyptian, Middle-Eastern, Arab states; and another team representing nations other than the principals--in a Mid East conflict). Staff, area experts and consultants filled the seventeen positions representing the various levels of the control team--civil servants, heads of state, observers and experimenters.

Impressions based on observations of the runs indicated the following: (1) the participants, even though college newspaper editors, lacked an appreciation of workings of international relations to a degree that they were unduly restricted in their roles (e.g., they made little, if any, use of the ambassadorial and intelligence information gathering functions available to them), (2) their lack of sophistication (and, in many cases, unwillingness to accept real-world assumptions in the game) led them to assume many unrealistic or ill-advised positions on policy

which, in turn, put them in sharp opposition to their respective chiefs-of-state (the experimental means used to control and correct major judgmental errors). Because of these difficulties, the data gathered was of limited substantive worth; however, they provided guidelines as to how the data should be restricted or augmented in future runs. The run also afforded us an opportunity to check out procedures for a six team run and demonstrated that the procedural arrangements operated with remarkable smoothness.

(6) Computer Program Development. Computer support for laboratory simulation was developed. A version of the program was implemented on the ARPA Q-32 computer; this operating system has the following characteristics:

- The vehicle will support a six nation configuration with six parallel "control" positions and a central control.
- The vehicle is compatible with, and effective within, the TSS time sharing system; most particularly, reasonable response times are maintained.
- Message units can be unpiored, routed and/or deferred from control positions.
- Commentary and coding (optionally suppressed) can be amended to any message at any time in the routing process.
- Central control automatically receives an information copy of all messages passing through the system.

The message units processed by the system are full text, open-ended, and variable-length; the system provides off-line

retrieval and summary capability based on chronology, sending action, receiving nation, or message coding. Using the remote station capability of the basic time sharing system, the program will accommodate nations at distant locations.

As the policy and theoretical issues become more sharply defined, the current version is designed to incorporate computer generated probes and the programmed simulation of selected environmental features such as trade, national economy, weapons distribution, etc.

3. Framework for Subsequent Simulation Studies.

With the experience gained from the first year's simulation activities, a new strategy of research was crystallized that represented a significant shift from our earlier approach. We became convinced that simulation designed to yield policy-valid or policy-useful information must first be validly (as defined by policy area experts) represented in the laboratory and only after this requirement is satisfied should the theory- and methodology-dictated requirements be allowed to influence simulation procedures. The order of implementation of these goals is of major importance in determining their ultimate joint realization. When introduced at too early a stage, theoretical and research considerations tend to exert a major effect on the specifications of laboratory simulation. While such specifications have served an important purpose in defining laboratory procedures needed to assess theory, the premature adoption of laboratory methods for these purposes may introduce significant

distortions in decision making processes, and most importantly, it may do so before these processes are adequately examined in a less artificially constraining simulation environment. As a result, the data generated in these studies are frequently the consequence of laboratory procedures rather than of reasonably evoked responses to the scenario crises or situations presented. We believe this severe criticism is appropriate for most research-oriented simulation studies in the international relations field.

If on the other hand, simulation "validity" is strengthened initially by the use of policy area experts in design and participation roles (rather than by theory and research goals), and if control is represented by experts (rather than by elaborately programmed submodels representing the environment and changes in it), then we believe this approach will increase the likelihood that research questions will be superimposed on a basically valid research vehicle. The consequences from this approach are obvious: 1) It will not only greatly reduce the perceived artificiality of the environment for expert players and their reluctance to participate in research-oriented simulation exercises; it should also increase the consideration policy analysts are likely to give results from such research studies. 2) The results obtained from the "policy defined" runs would serve as a frame of reference to evaluate modifications for the theory-testing research runs and as a way to identify policy issues and relevant variables for more detailed laboratory study.

(1) Development of a Manual Version of the Simulation Vehicle. Building on experience with the pilot runs, a manually administered version of the simulation was devised. One major reason for developing a noncomputer form of experimentation was to afford a more flexible and inexpensive means of checking out and modifying an interim version of the simulation vehicle and the anticipation of runs that would be physically remote from Santa Monica--specifically runs involving State Department and relatively high level military staff as participants. An equally important reason for the shift away from a computer-sequenced, cyclical mode with highly standardized procedures for participants toward a situation with minimal experimenter interference was to modify procedures in keeping with the preceding rationale. A reasonable balance was achieved with a model that was manageable in a manual mode, and was also compatible with the computer-based operating system. Further developments focused on some central aspects of methodology: 1) the procedures for updating the scenario between cycles, and 2) the procedures for monitoring play in process. The former need to be analyzed in order to insure against the intrusion of experimenter evaluative bias in the feedback process, and the latter need to be formalized in order to produce more effective data collection. Variations in the design of the manual game procedures were also introduced to reduce the frequency and arbitrary character of the intervention of control and the frequently encountered player resistance to control decisions. This was realized in one variation by

assigning players to newly defined roles of political advisors to the Heads of State rather than to the latter roles themselves. Accountability and responsibility of advisors was sought by requiring consistency between what advisors propose in their position papers and in their actual proposals for game moves. The use of Chief of State as an intermediary between players and experimenters plus the use of on-line nation monitors greatly reduced the need for and function of central control to monitor the legality of moves and to prevent gross inconsistencies or absurdities from entering into game play.

(2) Experimental Runs with the Mid-East Crisis Scenario.

(i) Procedures. Four runs of a manual simulation were conducted using the identical scenario of a Mid-East Crisis, with four groups of participants, respectively: college undergraduates; graduate students in social psychology and international relations; "Expert" players (from RAND, UCLA faculty); Department of State officers with desk assignments to countries represented in the simulation scenario.

In each run, four teams (three members each) represented Egypt, Israel, the United States and the Soviet Union. The rest of the world was represented by the Control Team, which also provided answers to requests for intelligence coming from the country teams during the game.

A scenario outline of 10 pages (DeWeerd, 1968), describing events from the present leading up to the emerging crisis, along

with a brief description of game procedures, were distributed to participants four days to two weeks before the run. Along with this, undergraduate and graduate students were given a specially prepared 50-page historical review and fact book of the Middle East scene (Shure, DeWeerd, Meeker and Carey, 1968a).

In brief, the Mid-East Crisis presented to participants was as follows: (The situation was made credible through the explanation of highly plausible intervening events, presented as a part of the scenario.)

The time: September 15, 1973. Arab commandos and terrorists have been causing increasing damage and loss of life in Israel. A secret working arrangement under which Israeli cargoes have been moving through the Suez Canal has broken down, and Israel threatens to reoccupy a UN-occupied demilitarized zone on the right bank of the canal.

Egypt threatens war if this occurs, and in the tense situation the aged Israeli statesman David Ben Gurion warns the Egyptians against attempting a pre-emptive air attack on Israel. He reveals that Israel has a small stockpile of nuclear weapons and a protected fighter-bomber force set to deliver them against Arab cities and the Aswan Dam, if the Arab nations should take out the Israeli Air Force in a surprise attack and strike at Israeli cities.

Upon arrival, after orientation briefing, each team met in its own room. In some cases a member of the experimental staff joined the team as monitor throughout the experiment. In the Expert run, monitors observed and kept notes of proceedings via closed circuit television from another room. Control also had a TV monitor available.

Each team was asked to select one of its members to act as its leader. The team was asked to jointly prepare, according to a general set of guidelines, a position paper as a reference for its own guidance and consistency as to actions to be taken and for reference use of Control and later use in analysis. On the basis of free face-to-face discussion, limited only by the time period of three hours per cycle, the team then prepared its first set of actions in response to the scenario situation on forms supplied for the purpose. These forms had provisions for recording explanations and qualifications (e.g., expected consequences, contingencies, etc.). Action forms were collected at the end of the cycle. They were analyzed by Control, who, before the next cycle, prepared an extension of the scenario which took into account the passage of time, the interaction of the four teams' moves, and actions by the rest of the world. One cycle consisted of one day's play.

When teams met for the second (and third) day's play, they received the new scenario extensions, along with moves directed

to them from other nations. They then reviewed their position paper, and prepared a new set of moves in response to the new situation, which faced them. The three cycles of play of each run were followed by a debriefing session.

- (ii) Data collection and analysis. The resulting protocols provide data that are relatively unique for a simulation study using a policy-oriented scenario: four records of performance that are comparable across levels of expertise and sophistication. Analyses, still in progress, are designed to identify the differences in team behavior and to relate these generally to characteristic differences among the groups along such dimensions as mode of problem definition, methods of problem attack, utilization of information, degree of contingency planning, extent of perceived constraints, sensitivity to adversary position, concern for the forms and expectations of international protocol, etc. These differences should be illuminating not only in a substantive sense but for subsequent developments in simulation methodology.

For a number of reasons--stemming primarily from the "sensitive" nature of the State Department run--the most complete and robust record was that obtained with RAND/UCLA area experts; it involves complete audio recordings of all teams for all sessions and video recordings of an unusually able UAR team. Transcriptions of these data were prepared for intensive analysis both in terms of the inter-run

comparison and for evaluation as a paradigm record for future studies. The reruns of the video tapes have already suggested that, when edited, they will serve as a new and interesting educational resource--stimulus materials showing how a group of experts respond to a simulated international crisis and revealing the process and the content of their policy making. These materials should be of particular value in orienting new players to the problems and range of options and to approaches evoked in the course of simulation. A complete documentation of the area expert run includes the action record, position papers, transcripts of team planning sessions, a post-run critique, and a parallel observations record produced by the experimenter-monitors (Shure, DeWeerd, Meeker, and Carey, 1968b, 1968c, 1968d, 1968e).

We expect the record will prove valuable as a basis for:

- Drawing out and relating information on variables presumed to be of significance in explaining team behavior and establishing categories for content analysis.
- Analyzing in detail differences in play that could not be discerned by on-line observation
- Aiding in the development of an on-line coding system (i.e., that makes verbatim protocols unnecessary) for use in future games
- Offering an information and checking source for SCENQUEST experiments

- Allowing an accurate review and critique by game players.

(The experiment did include a detailed debriefing session that has also been transcribed, but which raised questions that can only be answered by a review of the record.)

(iii) Preliminary Qualitative Results. Many features of the four runs have now been summarized in an internal memoranda, based on direct observations of the game. These show certain basic similarities and differences in style and content among the teams in the same nation roles, in response to the initial scenario and to the unfolding action of the game.

The runs have surfaced a number of policy questions about this type of scenario situation (involving Superpowers and 3rd-world nations) which might well be studied by other means. Examples:

- To what extent can the Soviet Union and the U.S. be expected to collaborate in a local crisis in which they have backed opposite sides? (In general, the Soviet Union teams appeared more willing than the U.S. to become directly involved in the Middle East Crisis.)

- To what extent and in what ways do Egypt and Israel desire to involve or avoid the superpowers in a Middle East confrontation?

- What opportunities and dangers are open to the great

powers for intervening in a Middle East crisis which arise in the presence of their two fleets in the Mediterranean?

• To what extent do crises provide opportunities to attempt solutions to underlying problems in the area?

The runs also highlighted a number of implications for the U.S. with respect to the period before Israel opts for a nuclear weapons capability. (These may be further studied by games or by other means such as SCENQUEST.)

Examples of such implications are:

- The game (as well as current events) seem to support the basic scenario, and indicate that the Middle East will increasingly become an area of superpower rivalry in the near future.
- As the U.S.S.R. extends massive military aid to the Arab nations, the United States must be concerned with the arms balance. Since straddling the issue by sending arms to both sides appears unlikely to get the U.S.A. off the hook in the Middle East, will the U.S. have to settle on one side ultimately?
- It would appear to be extremely unwise for the United States to let the arms balance in the Middle East tilt so far against Israel that it would be driven to make its own nuclear weapons. Should

the U.S.A. attempt to forestall an Israeli nuclear weapons capability by extending meaningful guarantees to Israel in advance of a decision on its part to go nuclear?

•What guarantees would Israel require to forego its own nuclear capability? and What is the U.S. prepared to offer?

- (3) Methodology for Structured Simulation Play. It has become increasingly apparent that a realistic political-military simulation requires a high level of sophistication on the part of the participant; the quality of the game depends in large measure on the players being aware of, and sensitive to, the objectives, the possibilities, the constraints, etc., in the situation; these, in turn, are dependent on such things as the traditions, long-standing policies, diplomatic practices, national goals, etc. which are clearly substantive matters beyond those who have not achieved some significant level of expertise. This raises the question of whether effective policy-making can meaningfully be reduced into the components of general cognitive skills and substantive content or whether it is sui generis. The question seems to be researchable if we could provide all critical substantive information in a manner that would not, at the same time, overdetermine the mode of cognitive approach and the decision mode. As a methodological strategy, we have gathered the substantive information produced by the

participants in the "expert" runs (local professionals and State Department), organized it, and then structured the task for the non-expert so that "relevant" content is systematically brought to his attention. In this way we wish to guarantee that the participant does not overlook any objectives, possibilities, constraints, etc. that have emerged from the experts working through the same situation. Since the method appears to be most effectively implemented in a programmed mode of presentation, we anticipate using the content of the expert runs, in conjunction with the general interactive program, to design a method for structured play.

- (4) Inter-Center Simulation. Computer methodologies were further tested with an inter-center simulation study. In coordination with Professor Robert Noel, Santa Barbara campus of the University of California, and Dr. Paul Hammond, RAND Corporation, procedures were developed for a simulation run involving participants from two geographically separate locations (Santa Barbara and SDC). Participants were drawn from graduate political science/social psychology seminar classes at UCSB and UCLA. Besides providing an additional set of protocols with the Mid-East Crisis scenario, the run yielded some preliminary assessment of educational utility and served as a shakedown run for the inter-center simulations that are planned for the proposed CCBS laboratory.

(5) Future Plans.

In the next phase of our laboratory simulation, we hope to enrich crisis gaming by linking it to the field of deterrence theory as it relates to U.S. involved crises in the third world area. We expect to check this effort by comparing the results to what has happened in similar crises in the real world (Korea, Quemoy, Vietnam). We are in the process of formulating a set of simulation-testable propositions in deterrence theory and a companion list of questions designed to help us explore how these propositions operate under conditions of successful and unsuccessful deterrence (Shure, Meeker, and Cooperband, 1969).

B. DATA MANAGEMENT AND ANALYSIS SYSTEMS

A significant portion of the project effort has been devoted to the development of computerized systems for interactive data management and data analysis. The thrust into this area was prompted by two aspects of the substantive research program: first, computer-based laboratory studies typically produce amounts of data far in excess of the usual experimental methods; and second, context-rich gaming (e.g. IR simulation) usually entails real-time information retrieval demands beyond manual processing capabilities. On both of these counts there was a perceived need for computer assistance in data management and analysis.

Programming development has taken two directions. First, there has been developed a general data management system (TRACE); and second, there have been developed computerized tools for inductive data analysis (IDEA). The two efforts are complementary in that TRACE is primarily concerned with "front-end" processing needs--inputting, editing, displaying and manipulating the data--while IDEA is primarily concerned with "exploratory" processing--with providing tools for inducing relationships from the data.

1. The TRACE Data Management System

TRACE (Time-shared Routines for Analysis, Classification and Evaluation) was initiated under a previous ARPA contract. At the outset of the present contract an operational version of the program (TRACE-II) was available for project research and to government agencies that had access to the Q-32 computer. During the present

contractual period the project continued with its user-related responsibilities, including documentation, program maintenance, and consultation on use. A revised user's manual was produced (Esada, 1967); the system was upgraded in terms of more efficient storage, improvement in response time, and interface with the IDEA program; and consultation was given to a number of users, including an extended analysis of equipment test data from the White Sands Missile Range (Sillman, Meeker, and Bowman, 1968).

The major effort during the contract period was devoted to the formulation and development of a more advanced data management system, TRACE-III (Cooperband, 1967, Cooperband, Moore, Meeker and Shure, 1969).

- (1) Rationale and Description. Experience with earlier versions of TRACE had shown the most powerful features of the system to be its capability to derive new measures and to reincorporate these into the data base so as to maintain associations with previous data. Since the derivation process is essentially one of writing special-purpose programs, the need for a redefinition of the objectives of the TRACE system became evident. Viewed more generally, the objective is not merely how to provide an experimenter with an **analytic** tool tailored to the kinds of questions raised in behavioral studies; rather, the need is for a system that permits an investigator or data clerk to produce special-purpose computer programs directly--using a language that is natural,

appropriate, and easy to learn, without his having to learn anything about computer programming--where the system assumes responsibility for, and automatically performs, those aspects of program development that are the major sources of difficulty and error even to experienced programmers. The need is for something analogous to what has been characterized as an implicit programming system.

In existing programming systems, the major obstacle a novice programmer encounters, and a critical source of annoyance to even an experienced programmer, is the almost universal requirement that he must completely define all of his current and future data structures before he ever specifies a manipulation of the data contained in these structures. A second obstacle is the need to make explicit the way these structures are to be filled initially from data stored on some medium, such as punched cards or magnetic tape. These two obstacles tend to limit the potential applications to those that can be anticipated beforehand; they are also major sources of error in programming. Other significant sources of program errors are: (1) in converting the user's indices of the data to programming indices for the data structures; (2) computing indices for cross-referencing from one part of a data structure to another or from one data structure to another; (3) maintaining associations among items of information residing in different data

structures; (4) determining where, within the defined data structures, the newly-derived information should be placed; and (5) providing for branching or tree-structured logic in the manipulative portions of the system.

These major difficulties and sources of error in existing programming systems are the result of requiring the programmer to be responsible for functions that can be performed by a general-purpose and comprehensive data management package. By generalizing the data management capabilities of TRACE-I and TRACE-II to handle multiple data bases containing information that may be multi-indexed, it has been possible to avoid most of the constraints and sources of error that exist in conventional programming systems. A further benefit of designing a programming system around a comprehensive data management capability is that it becomes possible to design a language that is virtually isomorphic with conventional algebraic, logical, and statistical notation, thus greatly simplifying and speeding the process of learning to use the system. Such a language can have an extremely compact and efficient notation, permitting a considerable reduction in the number of statements required to specify data manipulations (See Figure 1). Any reduction in the number of statements further reduces the opportunity for introducing programming errors. At the same time, however, it continues to be possible to provide special, guided interaction for the novice user. In accordance with the revised objectives, TRACE-III was designed to have the properties of an on-line

Algebraic formulae

Let $i = 1, \dots, t$ be treatment index,
 $j = 1, \dots, s$ be subject index,
 $k = 1, \dots, r$ be replication index,
 $n = tsr$,

$$C = X \dots / n, \text{ where } X = \sum_i \sum_j \sum_k x_{ijk},$$

$$C_i = \frac{n}{t} \sum_j \bar{X}_{1..}^2, \text{ where } \bar{X}_{1..} = \frac{1}{sr} \sum_j \sum_k x_{ijk},$$

$$C_j = \frac{n}{s} \sum_i \bar{X}_{.j.}^2, \text{ where } \bar{X}_{.j.} = \frac{1}{tr} \sum_i \sum_k x_{ijk},$$

$$C_{ij} = \frac{n}{ts} \sum_j \bar{X}_{ij.}^2, \text{ where } \bar{X}_{ij.} = \frac{1}{r} \sum_k x_{ijk},$$

$$C_{ijk} = X^2 = \sum_i \sum_j \sum_k x_{ijk}^2$$

Then:

$$MSI = (C_i - C)/(t - 1),$$

$$MSJ = (C_j - C)/(s - 1),$$

$$MSIJ = (C_{ij} - C_i - C_j + C)/(t - 1)(s - 1),$$

$$MSer = (C_{ijk} - C_{ij})/ts(r - 1).$$

And:

$$F_i = MSI/MSer,$$

$$F_j = MSJ/MSer,$$

$$F_{ij} = MSIJ/MSer.$$

TRACE-III equivalent forms

FOR I=TREATMENT, J=SUBJECT, K=REPLICATION.
 T = COUNT (OVER I); S = COUNT (OVER J);
 R = COUNT (OVER K);
 N = COUNT;

$$C = (\text{SUM OF } X)/N;$$

$$CI = N * \text{MEAN OF (MEAN (OVER J, K) OF } X)**2;$$

$$CJ = N * \text{MEAN OF (MEAN (OVER I, K) OF } X)**2;$$

$$CIJ = N * \text{MEAN OF (MEAN (OVER K) OF } X)**2;$$

$$CIJK = \text{SUM OF } X ** 2.$$

$$MSI = (CI - C)/(T - 1).$$

$$MSJ = (CJ - C)/(S - 1).$$

$$MSIJ = (CIJ - CI - CJ + C)/(T - 1)*(S - 1).$$

$$MSER = (CIJK - CIJ)/T*S*(R - 1).$$

PRINT MSI/MSER, MSJ/MSER, MSIJ/MSER.

Figure 1. Comparison of algebraic formulae and TRACE-III commands for two-factor, repeated measures analysis of variance, for equal n 's.

programming system. It represents a significant extension of the earlier TRACE systems in the direction of implicit, multi-dimensional data manipulation. It permits the non-programmer user to specify on-line, special-purpose data analyses or derivations that otherwise would require the preparation of special-purpose computer programs. With TRACE-III, the non-programmer user can specify and execute manipulations or analyses in minutes or hours that otherwise would require days or weeks for experienced programmers to write, debug, and run. As with the earlier TRACE systems, the result of each manipulation is added to a common pool of information in a way that preserves associations with previous data, thus making it available for any subsequent manipulations. Since TRACE-III can be operated **either** on-line or in a background mode, it offers the user the opportunity to pursue his hypothesis through a series of exploratory analyses or to perform complete special-purpose or standard analyses in a batch-job fashion.

To the user, TRACE-III appears as a single, monolithic program. Actually, Basic TRACE-III is composed of five essentially independent subsystems: (1) a command-language compiler that converts the user's instructions into a series of calls on processing routines in the other subsystems, (2) a data input package that builds or augments the data base, (3) a data retrieval package that constructs a local subset of the data base (an "array") on which the manipulations are applied, (4) a data manipulation package that operates on the local subset of data, and (5) a data base update package that incorporates the

results of data manipulations into the data base. This system structure is shown in Figure 2. Several of the subsystems are further subdivided into a number of related but independent program modules. Coordination of the various subsystems or program modules is accomplished by an executive program that follows directions placed in an Intermediate Language (IL) file by the TRACE-III compiler. Except during start-up, system execution follows the contents of this IL file, and thus ultimately is under direct control of the user.

When the system is first loaded, a start-up function establishes an initial data environment and then passes control to the compiler. The compiler requests instructions from the user and converts these to IL entries. After receiving an executable set of instructions, the compiler passes the IL file to a supervisor that calls on the appropriate program modules to follow the directions contained in each IL entry. When the entire IL file has been processed, the supervisor returns control to the compiler, which requests additional instructions from the user. Since the inputs to the compiler actually come from a file, rather than directly from the user, the compiler is indifferent to whether that input file is set dynamically in response to successive requests for more instructions or is specified in its entirety before the TRACE system is ever loaded. Thus the system can be used either in an on-line or a background mode of operation. Depending on whether the compiler's input file is under user control, the TRACE-III

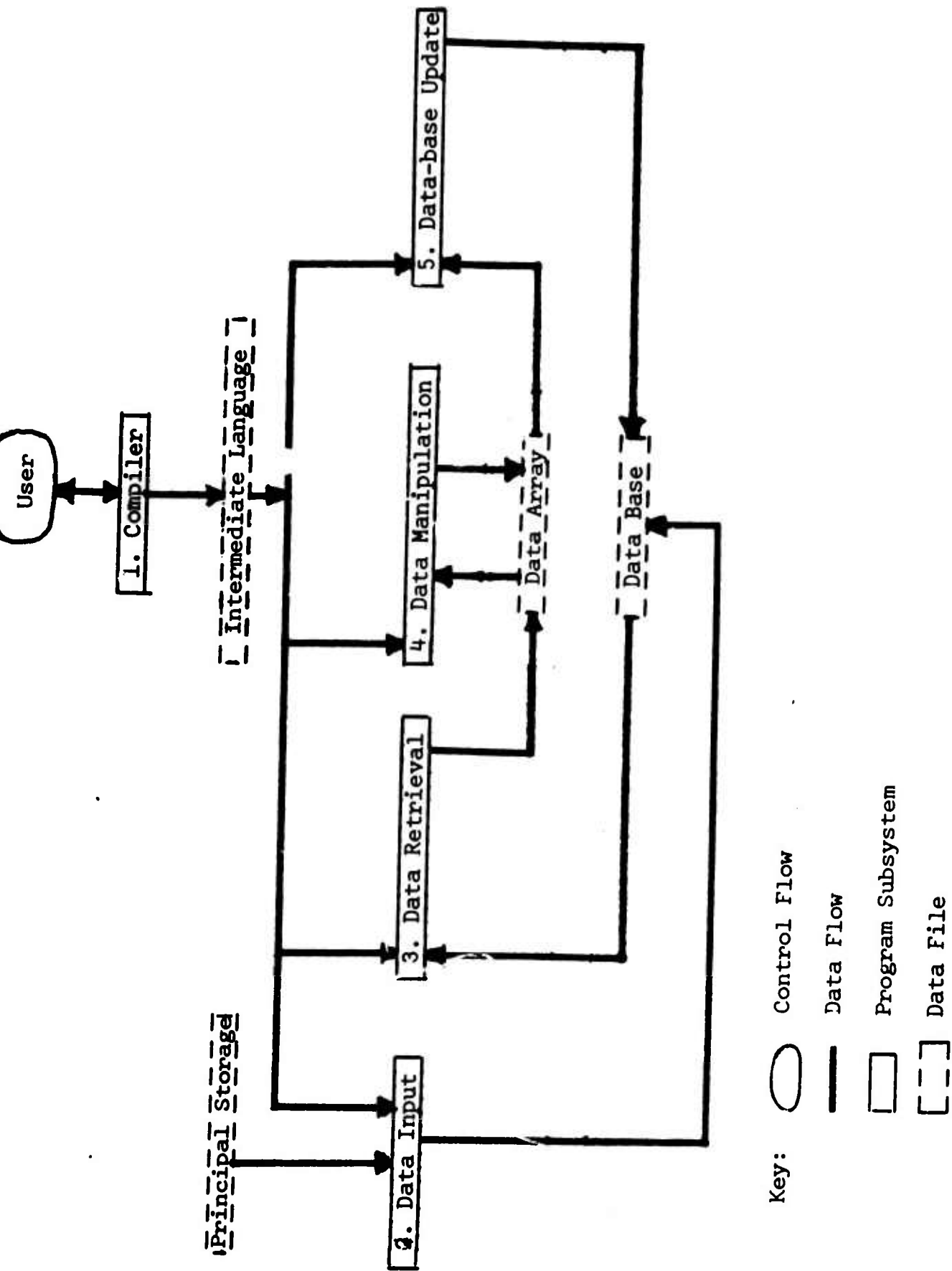

Figure 2. Configuration of the TRACE III System.

system can be alternated freely between interactive and background modes of operation.

(2) Developments. During the contract period, a working prototype of the system was produced. Developments include the following:

- General-purpose environmental maintenance supervisory program
- Specification of TRACE command language
- META 6 assembly-language-to-JOVIAL translator
- Command language compiler (written and debugged in Meta 6; then computer-translated to JOVIAL)
- Data input system
- Data retrieval array and generation system
- Data base updating system
- TRACE processing modules:
 - Arithmetic Boolean operators and transcendental functions
 - Descriptive statistics
 - Restriction functions
- Control functions (designed, but implementation deferred)

The working prototype has, of course, integrated the various processing functions under the general-purpose supervisor.

The prototype attests to the validity of the design concept and provides the basis for the anticipated implementation of the system in the context of the proposed Center for Computer-based Behavioral Studies.

2. Inductive Data Analysis.

IDEA (Inductive Data Exploration and Analysis) was initiated under the previous ARPA contract. At the outset of the present contract a prototype version of the program was operational on the ARPA Q-32 computer. During the present contractual period efforts have been directed toward increasing the efficiency of the program; extending its capabilities in order to handle different types of data; improving the interface with the user; and evaluating the effectiveness of the program heuristics in comparison with standard analysis methods.

- (1) Rationale and Design of IDEA. IDEA was developed for on-line interaction on the Q-32 computer time-sharing system. It is designed for discovering and summarizing potentially interesting data models in the form of restricted tree structures for a multivariate data base. It permits the investigator to collaborate with an open-ended library of programmed heuristics in the process of uncovering and representing the structure of his data. The result of an IDEA analysis is a decision tree that graphically represents the rule used to partition a set of observations (Shure, Press and Rogers, 1968). See Figures 3 and 4.

IDEA operates on the values of a number of variables that represent measurements taken over a set of entities such as interviewees or experimental Ss. For a given IDEA analysis, one of the variables is considered dependent. The group observations associated with a particular entity defines a point in a space that has one dimension for each variable. IDEA enables the investigator to develop a decision tree that

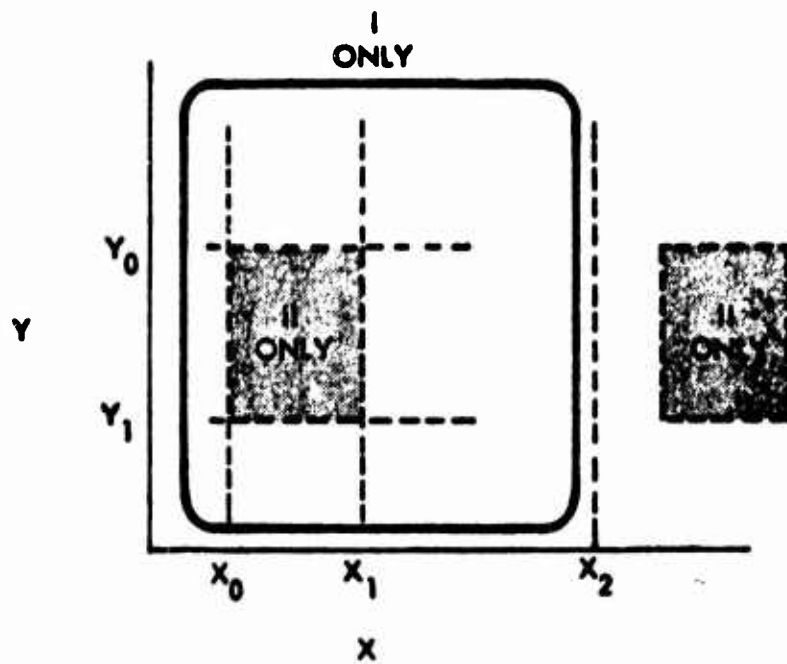

The independent variables are X and Y, which are measured on at least an ordinal scale. The dependent variable is nominal and takes on the values I or II in the indicated regions.

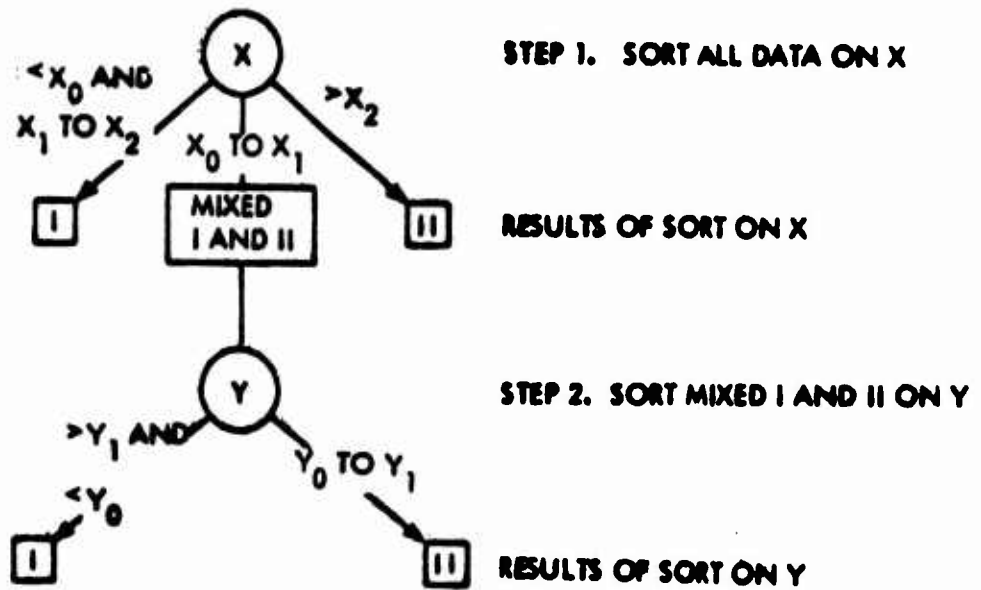

Figure 3. Hypothetical Data Base and Decision Tree.

- | | |
|--|--|
| 1. WHAT IS YOUR AGE? (AGE) | 3. WHAT IS YOUR EDUCATION LEVEL? (EDUC) |
| 2. WHAT IS YOUR SEX? (SEX) | 4. HOW OFTEN DO YOU ATTEND CHURCH? (RELIG) |
| 5. DID YOU PARTICIPATE IN THE RIOTS OR NOT? (RIOT) | |

Questions (variables) of hypothetical questionnaire for Watts residents

	AGE	SEX	EDUC	RELIG	RIOT
QUESTIONNAIRE 1	22	F	12	NEVER	NO
QUESTIONNAIRE 2	18	M	10	WEEKLY	YES
⋮	⋮	⋮	⋮	⋮	⋮
QUESTIONNAIRE N	45	M	6	TWICE A YEAR	NO

(Sample Data Base)

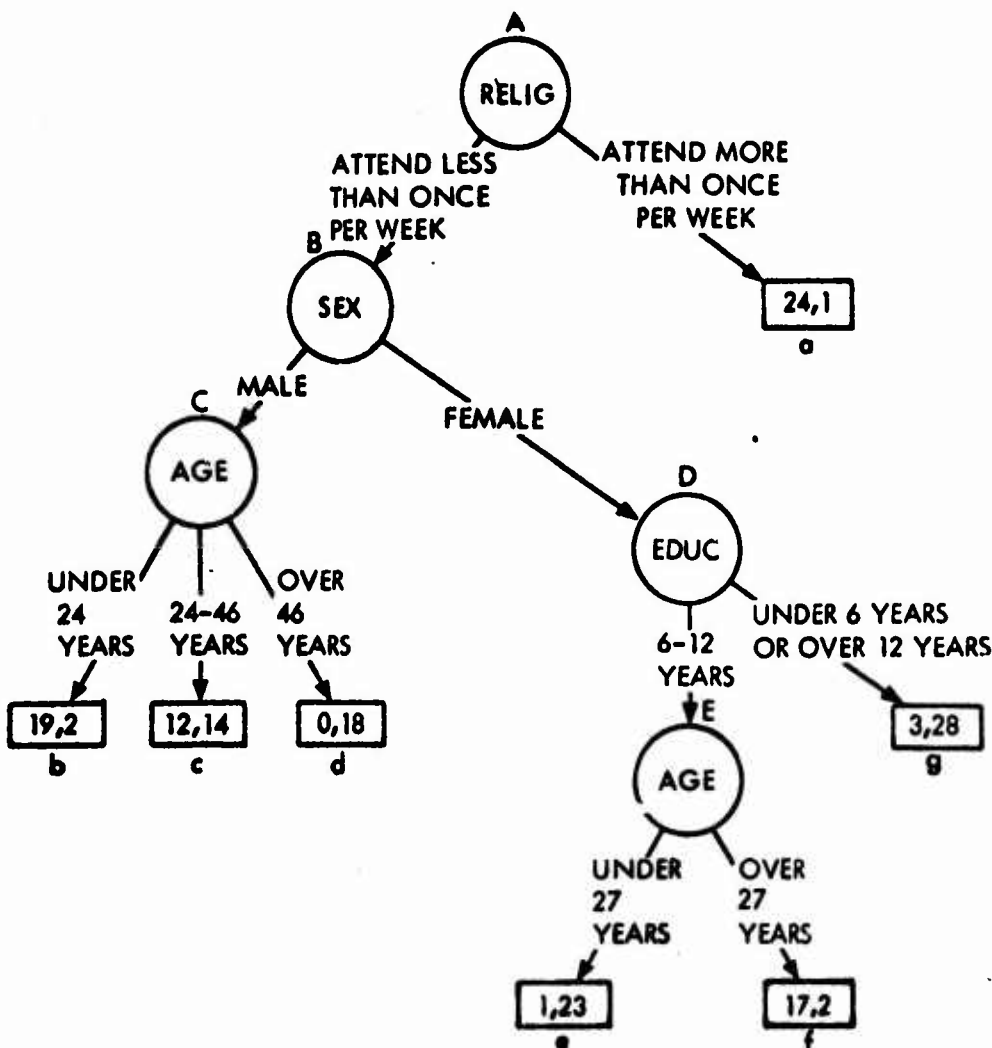

Figure 4. Sample Decision Tree From Watts Riot Data

In this display, RIOT is used as the dependent variable. A node (circle) specifies how the chosen variable is used to partition the entities which sort to that node. A leaf (box) contains a function (in this case the frequency distribution for the dependent variable) of the subset of the entities in the region represented by the leaf.

partitions this space into exhaustive, mutually exclusive regions.

The number of potential decision trees for any interesting set of data is too large to permit an exhaustive search for the best partitions; consequently, the routines that search for structure are heuristic. They seek out a subset of candidate variables for partition at each node of the tree. These promising partitions are then evaluated by means of heuristically chosen criteria for assessing the success with which a partition can explain the variation in the dependent variable. At each node, the program recommends which independent variable to use and how its values should be partitioned; the user retains the option to choose some other variable or a different set of partitions for the recommended variable. The same process that is used at the first step in the analysis, when the entire data base or a random sample thereof is considered, is also used for subsets at lower points in the tree.

Termination decisions are based on arbitrary thresholds for desired quality of fit, sample size, and improvement in quality of fit. A description of heuristics are presented in Press, Rogers and Shure, 1969.

- (2) Developments. During the contract period the initial prototype has been extended by the following developments:

User interaction features:

- .TTY only operation (especially for remote users)
- or CRT display light pen only operation (for more rapid operation)

- Optional hard copy for any position of program output
- Capability for saving trees generated
- User labeling capability for identification of program generated data categories

Heuristic evaluations:

- IDEA results compared with discriminate analysis as to accuracy of predictive classification (Press, 1967)
- Evaluation of effect of measurement error on consistency of results (Press, Rogers and Shure, 1969)

Extension in analytical capability:

- A mathematic description of IDEA (Marsten, 1969a) and a classification of its structure (Marsten, 1969b).
- Ability to sample randomly from data base for tree generation or for evaluating by sorting data sample through previously generated tree structure
- Option to compute biserial correlation and product moment correlation for cases sorted at any node
- Method for "collecting" all cases in given sample for which IDEA decision-tree were non-predictive
- Ability to include and evaluate time-dependency and time-lag characteristics in data
- Ability to "weight" variables according to pre-determined reliability of measures
- Ability for user to "trade" parsimony for predictive accuracy in decision-tree generation

C. COMPUTER-BASED LABORATORY--SOFTWARE AND FACILITY DEVELOPMENT

1. Computer-Based Laboratory Facility

The substantive research program for the project was predicated in large part on computer-based laboratory facilities; the international simulation aspect of the research proposed to use a computer-based laboratory particularly for the monitoring and administrative capabilities that it would afford, and the experimental studies aspect of the research proposed to exploit and further develop the computer-administered methodologies that had been developed under our initial ARPA contract.

The proposal for the present contract projected the necessary laboratory facilities being supported by the IBM 360-75 system then being installed at SDC. However, as early as the start date of the contract it was apparent that slippages with the 360 system would seriously impede progress on the research program. The decision was therefore made to develop laboratory facilities based on the ARPA supported Q-32/TSS system; after a series of software feasibility tests, this option was implemented. The System Development Corporation underwrote the costs for laboratory equipment and modification (approximately \$60,000).

The physical laboratory was substantially completed in the first six months of the contract period. The floor space was divided into one experimenter and six subject areas with isolation partitions for four further subdivisions of each subject area into four individual booths. In this configuration the 24 stations were physically

separable from one another by movable, sound-buffering partitions and were equipped with a dial telephone, a sound-attenuated, computer-tied teletype, and a television monitor receiving displays from a quadrant of the display surface of one of six DD-19 computer display consoles.

In addition, there were two observer positions equipped with teletypes and a television unit capable of viewing any current display of information stored in the system. Television and audio receivers also permitted direct visual monitoring of the station areas. The time-sharing system permitted separate but concurrent programs and users in addition to those employed in the on-line experimentation.

The laboratory was designed to reflect the need to accommodate two widely divergent experimental settings: (1) international simulation studies composed of a number of groups meeting face-to-face, required separate rooms for teams with three to six members, and the ability to monitor and record intrateam discussion, the facility to process and monitor interteam messages, and the experimenter capability to visually monitor the teams; (2) the experimental studies, frequently focusing on the individual subject, required separation of the participants from each other, all interaction, if any, mediated by the computer, and at the same time the visual and easy physical access by the experimenters to monitor and/or assist the participants. The flexible space divisions, together with the wide variety of combinations provided by computer-

tied TTY's, closed-circuit TV system, and telephones enabled us to support all aspects of the behavioral research program.

In overview, this multi-station, computer-based laboratory applies the various capabilities of electronic data processing--logical and arithmetic calculations, record administration, real-time controls, etc.--to the administration and management of our experiments; the conditions of investigation are conceptualized in terms of presenting, gathering, and processing information; the subjects (and, in some cases, the experimenter) are elements in a programmed loop that control and are controlled by these procedures.

The general pattern of information flow, processing, and control that is created by locating subject(s) in a programmed loop that embodies the procedures for administering given experimental designs is shown schematically in Figure 5.

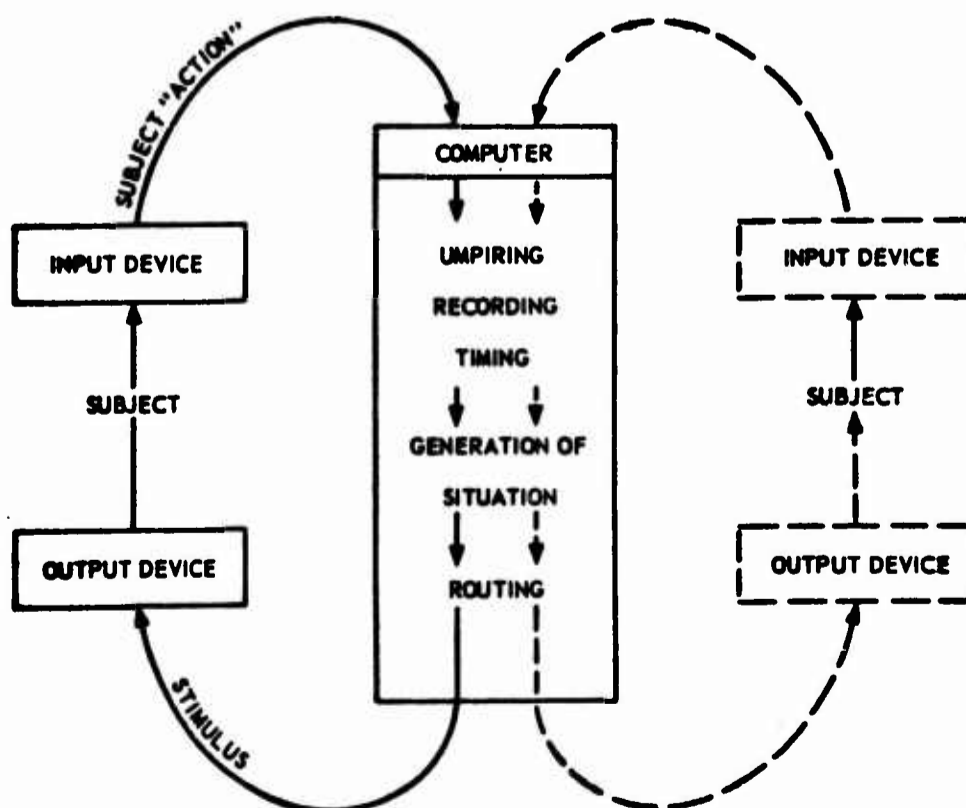

Figure 5. Diagram of information flow for multi-station computer-based laboratory.

Since all laboratory software was developed on the Q-32/TSS time sharing system during the period of the project, laboratory applications were embedded in the system as one of the twenty to thirty users that the system would concurrently support. Response times proved to be marginal on some occasions but, on balance, the system provided adequate support for the laboratory.

2. Computer-Based Laboratory Software

There were three major areas of work in laboratory software:

- (1) continual programming to support experimental research;
- (2) the design and implementation of a vehicle for international simulation studies;
- (3) a methodologically oriented development to provide a general interactive program designed to minimize the time, knowledge, and effort required to put a given piece of behavioral research into the laboratory. The computer program development for intervention simulation was discussed in the preceding section on simulation.

(1) Programming to Support Experimental Studies. The fundamental versatility of such a computer-based laboratory is shown by the wide range of experimental conditions and purposes that the same general purpose equipment can support (Shure and Meeker, 1969a). Over the course of the research program the following experimental research capabilities were developed and available to researchers using the capabilities of the laboratory.

(i) Pre-experimental assessment of individual differences among subjects.

A number of studies require systematic assignment of subjects to experimental conditions or in relation to one another based on measures of ability, attitude, or personality. It is often both more convenient and methodologically desirable to accomplish this within the experimental session. With questionnaires or tests administered through the computer, or answered on computer readable forms, responses can be scored and assignments made in a matter of minutes for groups of subjects. It might also be noted that with computer test administration the mechanics of assessment (e.g. counterbalancing order effects, etc.) can be handled very effectively.

(ii) Instruction and subject comprehension. For studies that are relatively complex, it is desirable to have some effective guarantee of participant understanding. Directions for the experimental situation and procedures can be cast into a form that permits them to be presented as computer-aided instruction; tests for comprehension and branches to remedial materials can be programmed into the presentation sequence in standard fashion; in fact, the whole technology of computer aided instruction can be used to increase assurance that subjects will not enter an experimental situation without satisfying a minimal level of comprehension.

(iii) Preparation and presentation of experimental stimuli. In one study, the creation of visual stimuli that represented all combinations of a number of variables, each with several levels, required the preparation of 100,000 unique display frames. It was then necessary to generate these in a random sequence for presentation to each

subject and to record and analyze associated responses. A generalized computer system was designed to do accurately and effectively what would otherwise have been impossibly burdensome and subject to error.⁹ Stimuli in a nonstationary environment have also been programmed to changes in pattern and proportion contingent upon subjects' responses.

(iv) Experimental Design. The ability to introduce experimental design variations are built into the administering computer programs in a manner that enables these variations to be set through controlling parameters--an operation so simple that conditions can be set or altered immediately prior to a given run. Different experimental conditions can also be realized within a single laboratory run. In a study involving a 2 x 2 x 2 x 3 factorial design, all 24 combinations were replicated in a single laboratory session (Meeker and Shure, 1969b), thus reducing the effects of exogenous factors that might selectively bias any particular set of conditions.

(v) Recording of social interaction. Dynamic interaction phenomena are important for the understanding of behavior in a variety of cognitive-social situations, yet the traditional methods for recording and analyzing social interaction data are extremely costly and place exorbitant time demands on highly trained professional personnel.

In our studies, the computer is employed as an on-line tool to assist in overcoming these limitations. By confirming the communication between subjects to messages that can be registered and transmitted by the computer,

⁹Cooperband, A. S. "The use of a computer in conducting psychological experiments." Behavioral Science, 1966, 11, 307-311.

we greatly increase the ease of acquisition and analysis of social interaction data. This is particularly important as longer or more complex sequential analyses are considered essential for analysis of interpersonal level (action-reactions) effects.¹⁰

- (vi) Control of social interaction through simulation of subjects. To increase comparability among subjects, it is often desirable to control one or more sides of a social interaction situation in which relatively simple fixed patterns of response are used to specify the behavior of accomplices in social psychological studies. The computer is able to extend the complexity of such studies in that it can present all subjects with a uniform or definable pattern of behavior that would be generated by a prescribed style, strategy, or set of tactics used in an experiment. (Shure and Meeker, 1968a; Meeker and Shure, 1969b.) The behavior of these simulated subjects can be generated in real time and can be based on very complicated algorithms that reflect prior stages of the environment and the real subject's behavior. The limitation on the degree of complexity is no longer the ability to generate the appropriate simulated response but rather the experimenter's ability to clearly and exhaustively specify the principles of generation.

In addition to offering the improved efficiency of commonly used procedures, the computer provides other experimental capabilities, most of which would not otherwise be practical.

- (vii) On-line questioning to elicit subjective amplifying information. To augment the basic data being collected, the computer can be programmed as

¹⁰Shure, G. H., Meeker, R. J., Moore, W. H. Jr., and Kelley, H. H. "Computer studies of bargaining behavior: The role of threat in bargaining." SDC document SP-2196, 1966.

a real-time interviewer to elicit from the subject his ongoing and developing perceptions of the situation, his reading of the other's intentions, etc.--indeed, any information that the investigator might find useful in interpreting the subject's responses. To elicit these pertinent subjective data at the time when it is most relevant demands, for many situations, the ability to record and analyze at a rate more rapid than that of ongoing subject behavior. The computer provides this capability, serving as a standardized interviewer who carefully, but unobtrusively, monitors all participating subjects, detects all situations about which further information is desired, and then selectively asks questions relevant to what has just occurred. The desirability and usefulness of supplementary response data with in-process reports has been demonstrated in a number of studies.

(viii) In-process assistance in experimental tasks. The computer can be used as an aid to assist the subject in the experimental task: to keep running totals, to retrieve information on the history of the situation, to extrapolate trends, etc.; in fact, to retrieve or generate any information that the investigator wants to provide to the subject.¹¹ In laboratory studies of complex real world situations, this capability is being expanded to include on-line access to large data archives through sophisticated data management techniques.

(ix) Enriching the communication language. Beyond registering a simple choice among presented alternatives, it is possible to use the computer

¹¹ Meeker, R. J., and Shure, G. H. "Self-administered instructions for the territories game." SDC document TM-2442, 1965; Rome, Beatrice K. and Rome, S. C. "Leviathan and information handling in large organizations." In A. Kent and O. E. Taulbee (Eds.), Electronic Information Handling, Washington and London: Spartan Books and Macmillan and Company, 1965, Chapter 16.

to permit subjects to construct responses that are not as restrictive as multiple choice, and not as unwieldy (for the data analyst) as open-ended responses. This has been accomplished by presenting the respondent with a grammatically structured tree by which he can construct statements, commands, declarations, etc. of significant complexity.¹² This falls short of the desired capability to accept and process natural language, but it has proved to be a significant step in this direction.

- (x) Communication networks. In a given experimental session, we could accommodate twenty-four individuals acting independently, twelve interactive pairs each independent of the others, and so on up to one large group with all members in an interdependent network of relationships. Computer mediation of interactions among these positions permits the investigator to set and alter the communication network in almost any specifiable fashion. Complex and varied organizational hierarchies have been represented and studied in this manner in the laboratory.¹³ It is also possible to dynamically vary the communication structure. In one bargaining study, it was possible on each trial to link each player with a new adversary drawn from a pool of the 23 other subjects. This methodological innovation has permitted a unique test condition for testing prescriptive strategy that is almost impossible to realize otherwise (Shure and Meeker, 1968a).

An additional by-product of computer management of the communication network is that physical arrangements and network properties become

¹² Almquist, Mildred L. "GOCI: A general-purpose vehicle to assist system communication." SDC document TM-805/001/00, 1963.

¹³ Rome, Beatrice and Rome, S. C. "Communication and large organizations. SDC document SP-1690/000/00, 1964.

independent of one another, and as a result inadvertent clues as to personal identity and topological properties of the net cannot be inferred from positional relationships as frequently occurs in small group communication network studies. A more important advantage that is gained is that through the use of standard communication lines, subjects in the same computer-based experiment can be simultaneously in different geographical locations, literally from all parts of the country. All that is required are input consoles compatible with the laboratory system. This capability should greatly increase the ability to obtain appropriate or needed samples, particularly in simulation studies that may require the participation of teams of expert players over extended time periods, who would otherwise be unable to schedule time for such participation.

- (2) "Getting Into" the Laboratory. If the potentials of the computer-based experimental vehicle are to be profitably exploited by the behavioral research community, provision must be made to get the investigator into the laboratory. Past experience suggests that although investigators generally perceive the potential of the computer-based laboratory, they are more strongly aware of obstacles involved. First, the operation itself is not generally understood. Investigators are not programmers and for the most part, are unfamiliar with control systems. Second, the lead-time to see concrete results seems inordinately long. Most behavioral investigators are used to building their experiments in successive stages, with frequent opportunities for testing and modification. Third, the specification process is unfamiliar. Each experimental vehicle is a program system, requiring specifications to

cover all interactive contingencies. The art of producing such specifications is not easily assimilated and is not worth learning for the infrequent user. To overcome these barriers, a means of effectively translating the investigator's requirements into an operational program needs to be provided.

We have taken a number of approaches to ease the problem of getting the investigator into the laboratory: (1) Developing a "laboratory language" so that the investigator can do his own programming. This approach is due to the fact that higher order languages are programmer- rather than researcher-oriented and are notably weak in I/O (input/output). These latter functions are those that have high usage rates in any laboratory application. (2) Constructing a "universal" laboratory program so that the investigator can build his laboratory vehicle from a menu of preprogrammed functions. Programs using this approach are not particularly well suited to real-time control operations and tend to have less efficiency since overhead is directly related to the degree of potential complexity of the application. (3) Providing the investigator with a general, interactive vehicle that permits him to rapidly operationalize his experimental design logic and poses formulation problems in concrete form, thus giving him the opportunity to "breadboard" his experiment by putting him immediately into the operational context and allowing him, by trial and error procedures, to successively approximate his final research design. These quick approaches to laboratory use should

significantly reduce the design-to-implementation phase of experimentation development.

"A breadboard" program should provide for the following functions:

(i) ability to create an interactive network by parameters setting

- any combination of participant and control positions
- each participant position associated with local control level (one-to-one or many-to-one)
- local control positions may or may not be related to higher control
- all participant interactions pass through respective control (by passing control is dependent on subsequently specified processing logic)

(ii) ability to construct menu of control-to-participant presentations

- specification of format and content by user
- reference by code
- routing by parameter to program demand
- full update, sequence and edit capability

(iii) ability to record and reproduce any of following patterns of interaction

- presentation record by participant position
- response record by participant position
- processing record by control position
- historical record

(iv) ability to commit processing logic to computer programming

- ability to key logic (umpiring, routing, and feedback) on presentation-response
- ability to relinquish processing control to program (thus bypassing control)
- ability to revise logic specifications.

The prototype of such a program has already been constructed on the Q-32 computer; transfer to another operating system should be greatly facilitated by this development. The prototype has also provided preliminary evidence that the general strategy is practical. Still problematic is the question of whether user-interactive procedures can be developed to the degree necessary to simplify the subsequent programming task to a "parameter fitting" level.

The general "breadboard" program will prove to be least satisfactory for those investigations in which the sole or primary mode of interaction is conversation or open text (i.e., where the participants "actions" are message exchanges and similar forms of verbal interactions). Investigations of this type are characteristically so open-ended that the model of serial response-demand presentations is nearly inapplicable; more appropriate to such investigations would be a program modeled on a memo-passing paradigm--addressing functions, copy functions, comment functions, etc. Thus, a second general laboratory program is required to support this important class of investigation; it should provide for the following functions:

- (i) ability to create interactive network by parameter setting
 - participant positions associated with identification name
 - control positions related to participant positions and associated with identification name
- (ii) Ability to initiate variable length messages at participant and control positions
 - with or without format
 - with or without demand presentation
 - with or without initiator routing parameters
 - with or without "blind" comments

(iii) ability to preprocess messages at first level control

- optional routing functions
- optional capability to generate information copies
- optional capability to umpire or edit
- optional capability to ammend with comment (open or blind to ultimate recipient)
- optional capability to suspend processing--subject to recall
- optional capability to defer processing to higher level control

(iv) ability to review messages at first level control prior to ultimate receipt

- optional capability to ammend with comment
- optional capability to suspend processing--subject to recall

(v) ability to receive messages at addressee position (participant or control)

- on demand or under recipient control
- optional capability to ammend comments

(vi) overall ability to record and retrieve messages

- routing record with times
- full text with or without "blind" comments
- retrievable on basis of:
 - initiation times
 - receipt times
 - initiators
 - recipients
 - coding categories

A prototype of this program has also been constructed on the Q-32; its capability would be greatly enhanced in a hardware environment that permitted rapid generation of displays (e.g., storage tube graphics would be ten times faster than the current teletype output rates). For verbal interaction types of experimentation, this prototype has the same features of quick implementation that the breadboard program provides for more formal and structured modes of experimentation. While the two prototypes were initially developed independently, the aim is ultimately to combine their separate capabilities into a single vehicle that will accommodate either or mixed modes of investigation.

D. ON-LINE USE OF EXPERIMENTAL AND NON-LABORATORY TECHNIQUES

The simulation approach, because of its complexity, particularly needs to be closely interrelated at many levels with other techniques of investigation, both to clarify its findings and to serve as a direct source of hypotheses. It is necessary, then, that the research program continue to range widely in its approaches to problems, from paper-and-pencil situations to computer-based experimentation. In particular we continued three lines of investigation in parallel and in support of the simulation activities: 1) our program of experimental bargaining studies in the new computer laboratory, 2) SCENQUEST studies, and 3) a propositional inventory of American character traits that may influence diplomatic and negotiatory behavior.

1. On-Line Computer Experiments in Bargaining and Negotiation Processes

These studies have continued to investigate bargaining and conflict resolution behavior in situations where parties had interests that conflict as well as interests in common; that is, where they were mutually dependent in the pursuit of otherwise opposing goals. In such situations, the bargainers frequently employ tacit means of communication, proceeding primarily through actions and maneuvers rather than through direct exchange of explicit communiques; they are able to impede one another, and to inflict loss or harm on the other party; they are frequently unclear about the values and power of the other party. Under such conditions, which breed mutual distrust, how do negotiators succeed in mutually influencing one another to contain or resolve their conflict? What are the characteristics of the exchange of moves and signals that lead to unilateral advantages or successful

joint resolution? If limited wars imply limited victories--and sometimes limited defeats--are the factors that break the implicit limits and lead to conflict escalation identifiable? Can the properties of the bargaining context, or characteristics of the parties in the conflict, be identified as critical influences on the resolution process?

These larger questions still continue to bound the area of our research interests. Our previous experimental studies using two-person nonzero-sum bargaining games have reported on a wide variety of independent and dependent variables. The beneficial and deleterious effects on bargaining processes and outcomes of unilateral and bilateral threats and threat action have been studied under conditions of (1) tacit or limited communications between adversaries, (2) single move, repeated trials or multi-move games, (3) knowledge or uncertainty of the adversary's value structure, (4) variations in potential for mutual accommodation, (5) variation in range of potency of threat reprisal moves (affording and opportunity to study escalation processes), (6) variations in game complexity and requirements for problem solving to reveal the degree of potential for jointly acceptable agreements, (7) variations in individual and paired bargainer's personality characteristics and attitudes, (8) variations in bargainer's orientation and perceptions of game situation and adversary, and (9) firmness or resolve of adversary's strategies.

Another series of studies has focused on the conditions bounding the effectiveness of cooperative and conciliatory strategies where the computer was used to simulate one member or team of adversaries.

Among the variables studied were the presence or absence of neutral observers, knowledge about the adversary, variations in payoff incentives, adversary's moral persuasiveness, prior experience of bargainer, variations in procedural safeguards that guard or fail to guard against unexpected losses or hostile actions by the adversary, variations in the risk associated with unilateral initiatives, etc..

As noted in the preceding section, the on-line computer administration of these studies not only permitted us to obtain more complete move and action data for process analysis than typically collected in similar studies, but these data were also augmented by on-line computer replies to computer questioning of subjects during the course of the experiment itself. These data, analyzed by programs like TRACE and IDEA, permitted the maximum inductive potential to be realized.

Reports on a number of studies have been completed during the period of the project; other studies are still in various stages of completion. These are briefly summarized. Reference should be made to the published documents for fuller discussion.

- (1) Pacifist Bargaining Tactics: Some "Outsider" Influences (Meeker and Shure, 1969). This paper is a follow-on report to previous research concerned with the effectiveness of pacifist tactics in modifying an adversary's behavior in a bargaining game.¹⁴

Pacifist bargaining tactics are predicated on a moral appeal:
Efficacy of pacifist tactics is dependent on the adversary's view

14. Shure, G.H., Meeker, R.J. and Hansford, E.A.. "The Effectiveness of Pacifist Strategies in Bargaining Games", Journal of Conflict Resolution, 9.1 (March 1965), 106-117. Details of game procedures are presented in the report.

of the morality of the situation, in terms of the clarity of his perception of his pacifist opponent, and the persuasiveness of the pacifist tactics in attempting to change his behavior. Perhaps because of complexities surrounding it, pacifism has seldom been studied under controlled conditions. The present study extends a series of laboratory investigations of pacifist bargaining strategy concerned with the basic conditions necessary for pacifist tactics, the general efficacy of the pacifist appeal to a belligerent adversary, and the differential effects of a variety of potentially influencing conditions: direct communication (vs. tacit bargaining) explicit characterization of the pacifist (vs. implicit characterization as reflected in tactical interaction); potential equality of outcome (vs. outcomes without equal share possibilities); and explicit guarantees of non-retaliatory tactics by the pacifist (vs. no explicit given guarantee). Against a background review of previous findings the present study is particularly addressed to the effects of two different "outsider" influences: cohort support for the adversary's position (vs. independent determination of position); and social context in terms of a third party reviewing, but not directly engaged in, the interaction (vs. a pacifist-adversary context with no outside audience).

These variables were studied in a mixed-motive bargaining game administered on-line by a computer. The game is characterized by a condition of unilateral fate control directly involved in the bargaining process: "Sharing" of outcomes requires that the bargainers pass control of the game back and forth to one another trial-by-trial; prolongation of control is potentially guaranteed but requires, in the

face of passive resistance, that the controlling bargainer deliver a series of electric shocks to the other player. A wide variety of methodological techniques, including use of computerized questioning, were employed to gather relevant phenomenological and behavioral data. Results are reported on 238 male college students, all of whom (as adversaries) faced the same (simulated) pacifist player under the potentially influencing conditions outlined above.

The results of these experiments showed that, on balance, the presence of "outsiders" had no appreciable influence on the effectiveness of the pacifist's moral appeal in the course of the bargaining process. Subjects who have cohorts (who ostensibly provide a rationale for dominating the pacifist and for resisting the pacifists morally based bargaining strategy) are initially less cooperative, but subsequently are no less resistant to pacifist appeals than those subjects who have no cohorts. On the other hand (the influence of cohorts eliminated) subjects reacting to the pacifist under the passive, but constant review of an observer, are initially more cooperative, but subsequently less persuaded by pacifist tactics than subjects with no third party observer.

From these results it appears that the findings of our earlier investigations need not be drastically reinterpreted, but different questions--especially concerning the reasons for the observers not having more of a pro-pacifist effect--have been opened for possible future exploration.

(2) Bargaining Processes in Experimental Territorial Conflict Situations

(Shure and Meeker, 1969). This study investigated the effects of threats

upon bargaining processes and outcomes in a two-person, mixed-motive game designed to make the informational and persuasive aspects of game communications highly salient. Of particular concern in this study were issues and strategies in bargaining that are evoked where communications between parties are limited to tactic means, proceeding through actions and moves rather than by direct exchange of explicit communiques. Under these conditions bargainers possess, to a greater or lesser degree, the means to impede one another and to inflict loss or harm on each other; at the same time, they are frequently unclear about the values and intentions of the other party.

Behaving under partial information, the communication and signalling process assumes critical importance. Misperceptions of signals revealing intentions, willingness to use force, and the vital importance and acceptability of options may lead to serious errors in tactical and policy decisions. Yet it is inherent in the mixed-motive situation that adversaries seeking an advantage will make deliberate efforts to conceal basic information from each other. The problem is further compounded if at the same time, there is also a problem-solving component in the situation that requires the players to share and reveal information in order to enlarge the possibilities for accommodation of their common interest.

How, under such conditions, can negotiators succeed in mutually influencing one another to explore possibilities to contain or resolve their conflict? What are the characteristics of the exchange of moves and signals which lead to unilateral advantages or successful joint resolution? If limited wars imply limited victories--and sometimes

limited defeats--what are some of the factors which help define the implicit limits of coercive moves and may lead to limits being broken? Can the properties of the bargaining context, or characteristics of the parties in the conflict, be identified as critical influences on these conflict processes?

To make more salient the informational and persuasive aspects of game communications, the Territories Game differs from the typical conflict resolution laboratory games in a number of important respects:

- It is a multimove game (play is extended and continuous) as contrasted with games in which the play and outcome are determined by a single move or trial, or in repeated trials.
- Players begin the game without initial knowledge of the adversary's value structure. As a consequence, no obvious basis for a "fair share" resolution is provided--the bargaining values are not given, but must be inferred in the course of bargaining moves.
- There is a problem-solving component to the game that requires players to share and reveal information in order to discover the full potential for accommodation that is present in the situation.
- It permits tacit signalling of intentions and information through a richer vocabulary and range of game actions than that used in the most conflict resolution experimental studies, which typically do not permit any escalation through levels of threat, nor provide a sufficient variety of possible trades and compromises, nor permit the communication

of preferences on other than "all-or-none" basis.

- It affords variations in the level of situational (objective) conflict of interest over available outcomes against which the uses and consequences of threat may be examined.

An experimental design including three levels of conflict of interest and three configurations of threat assignment to pairs; low-low, high-high, and low-high were studied. The computer was employed to present, umpire, monitor and record the exchanges between players. In some conditions the computer also was used to question the subjects during their interaction.

The following findings were obtained:

- The three levels of conflict of interest induced three parallel levels of behavioral conflict; joint net outcome was inversely related to the degree of conflict of interest.
- In high-conflict situations, poorer net outcomes resulted from increased bargaining costs--losses associated with coercive moves or protracted periods of time required to reach an agreement.
- The quality of the final agreement, as measured in terms of what was jointly possible, did not differ across the three levels of situational conflict even though solutions at the highest level required highly asymmetrical divisions of the outcome between opposing players.
- Bargaining pairs with high bilateral threat capabilities had poorer bargaining outcomes than pairs with low threat capabilities.

- Comparisons between the two high-high threat conditions showed that information gleaned from being asked questions during the course of the game led to overall improved outcomes due primarily to the avoidance of losses in situations of low- and medium-conflict of interest. It appeared that where the level of inherent conflict was irreducibly high, and coercive moves were available, the informational value of the questions did not mute the adverse effects of high threat availability.
- Characteristics which players brought to the game influenced pregame plans, perception of plays, and frequency of use of strong coercive acts. Furthermore, the role that a particular attribute played in contributing to or subtracting from successful bargaining outcomes depended on the overt level of conflict of interests.
- Differences in the emphasis placed on integrative (problem solving) versus distributive (competitive) aspects of bargaining were reflected in the tendency to either hide or reveal the value of one's positions. Bargainers who planned to cooperate were more open in this regard than those who planned to maximize their own earnings. Overall completeness of the information exchange severely limited their problem-solving ability.
- In all conditions, initial expressions of a competing demand for a square were more likely to be made with the least provocative move available. At the same time, the stronger the countermove, the greater the likelihood that it resulted in

the desired immediate withdrawal. In the low-low threat condition, this immediate advantage was lasting, but where stronger moves were available, as in the high-high threat conditions, the initial advantage of the same moves was lost in subsequent counter-claims. It appeared that for bargainers with equal threat capabilities, the coercive effectiveness of a threat is defined by the maximum capability that the bargainer brought to a situation. The presence of stronger coercive capabilities seemed to devalue the bargaining currency of moves.

• In spite of the need and use of stronger acts to communicate resolve in the high-high threat variations, local conflicts, (fights over squares) rarely escalated uncontrollably to maximum possible levels. Both parties imposed limits on the level of their coercive acts by avoiding the imposing of penalties and threats of these.

• In the low-high threat condition, this restraint was significantly less in evidence as the player with stronger moves used his strategically advantageous position to obtain more favorable outcomes. These findings suggest that the restraint noted in the high-high threat variations was not based on an ethical reluctance to use the more harmful moves to obtain a bargaining advantage, but rather on consideration of strategic utility.

(3) Personality, Perceptions of the Adversary, and Plans to Cooperate in a Two-Person, Mixed-Motive Game (Gold, 1968). In order to understand the bargaining process, and to make cross-study comparisons in game research, it is necessary to investigate the psychological behavior of the bargainers both before and during the game. Most researchers have not reported this kind of data; thus, it has not been possible either to explain precisely why different results have been obtained from experiments investigating the same variable or to know what subjects were thinking when they made certain choices.

This research investigates both long-term behavior (i.e., personality and attitude) and short-term behavior (pre-game perceptions of the adversary), as these behaviors are related to pre-game orientation toward bargaining in a two-person, mixed-motive game. The following general hypotheses were supported by the data: (1) In an ambiguous situation where bargainers have little empirical knowledge of the adversary on which to base their perceptions or plans, long-term characteristics of personality and attitude do not affect pre-interaction psychological behavior--specifically, plans to cooperate or not are not related to measures of belligerence or nationalism. (2) In the interdependent environment of a mixed-motive game, perceptions of the adversary are related to plans to cooperate or not--specifically, where information about the adversary's attitudes on issues was provided. Internationalists were more likely to plan to cooperate, and nationalists to plan not to cooperate. Moreover, belligerence had an additive effect: Internationalists who were also low belligerents were most likely to plan to cooperate and Nationalists who were high belligerents were most likely to plan not to cooperate. Thus, there was an interaction

between one's own personality and information about the other. (3) When information is provided about some of the adversary's beliefs, and these beliefs are in disagreement with those of a participant, stereotypic images of people who hold such beliefs are called forth; these are reflected in the participant's perceptions of his adversary--specifically, internationalists tended to perceive nationalists as more tough (i.e., strong, active, and likely to get tough when threatened), and nationalists tended to perceive internationalists as less tough (i.e., weak, passive, and likely to yield to threats). Thus, nationalists, perceiving the other player as yielding, planned not to cooperate; they had reason to suspect that they could succeed with a strategy of exploitation. Internationalists, perceiving the other player as tough, could not expect to succeed by exploitation, and thus planned to cooperate. Again, there is an additive effect of belligerence when looked at in conjunction with nationalism. Internationalists who were personally conciliatory were most likely to perceive their nationalist adversaries as tough, and nationalists who were personally belligerent were most likely to perceive their internationalist adversaries as yielding. Thus, it may be concluded that the plans of nationalists and internationalists differed, that the personality characteristic of belligerence interacted with nationalism, and that plans were at least logical on the basis of the perceptions of the adversary.

Methodologically, this investigation underscores the point that pregame data (of the kind obtained) can provide a means for comparing the results of various experiments. If data were available, for example, on the pregame bargaining orientation and perceptions of

bargainers in the experiments that investigate the effects of threats in bargaining, we might better understand what appear to be contradictory findings. (Between-trial psychological data would provide even more information and understanding of the bargaining process.) In fact, without such data, we are left to conjecture about differences in set provided by instructions and the structure of the game itself. If game research is to build cumulatively on the findings of various experiments, psychological data of the kind reported here must be collected and analyzed by all investigators.

(4) Incentive, Jeopardy and a Simple Social Contract in Two-person Interaction. (Daniels, Meeker and Shure, 1969). The Bartering Game used in this research was designed to study the development of bargaining trust under different conditions of situationally defined risk and jeopardy. The study explores the importance of procedural factors in bargaining situations that guard against, or fail to guard against, the danger of unexpected loss for either or both parties.

Two experimental variations are of primary interest: (1) Mode of contract determination: In a jointly determined contract condition, both participants must agree on a proposal before a trade agreement is reached; in the unilaterally determined contract condition, every offer is open to exploitation by the other party. (2) Level of proposal cost: High and low costs create conditions of greater or lesser risk associated with bargaining actions.

These two variations were expected to interact, serving to create differences in perceived jeopardy. Thus, in the unilaterally

determined contract condition, since proposals are not conditionally protected by contract agreement procedures, self-defeating patterns of bargaining exchanges were anticipated where proposal costs are high.

The four combinations of the two experimental variations were run with 12 pairs of subjects in each condition. In accord with predictions, where subjects were required jointly to reach a binding agreement before either could act in a way affecting the other, increased incentives and associated increased proposal costs led to the highest outcomes. Where subjects could act independently, without requiring agreement from the other bargainer to a proposed action, increased incentive and proposal costs led to poorest outcomes. Thus, increased incentive for successful negotiations may make it more rather than less difficult to initiate successful offers and agreements if the party initiating the proposal must place himself in a state of even temporary vulnerability to exploitation (as in a decision to disarm unilaterally).

Results showed important differences between bargaining modes (the contract condition produced better outcomes than jeopardy condition), and there was a significant interaction between bargaining mode and incentive condition (the contract condition produced better outcomes with money incentives, while the jeopardy condition produced better outcomes with points incentives)--in other words the most productive bargaining was obtained where risks were low but incentive high, or where risks were high but incentives low; and overall the

most productive bargaining was obtained under low-risk, "good faith" bargaining conditions.

While these results are not particularly unexpected they provide sobering evidence of the importance of dimensions of bargaining that have largely been slighted in the conflict resolution literature; namely, that contractual bargaining for high incentives (the most usual mode of bargaining outside the laboratory) is not only the most productive, but is not continuous with the most usual mode in the laboratory (jeopardy conditions with low incentives). In sum, the results from this study help to clarify the form of influence of a pervasive, structural feature of many bargaining situations, and to clarify some inconsistent effects of incentive variations reported in experimental studies.

(5) Empirical Demonstration of Normative Behavior in the Prisoner's Dilemma (Shure and Meeker, 1968a). Research on the Prisoner's Dilemma (PD) situation has assumed a substantial and growing importance in the literature of experimental gaming. Within that context, the present study was concerned with empirical investigation of a narrow, but important, range of conditions that serve to explicate the notion of "rational" play within the PD situation--it was designed to show that under a limiting condition of repeated play, subjects will, in fact, adopt a "rationally" prescribed strategy in which they persistently choose the dominant alternative and strategically ignore the choices of the other player. These results constituted the first compelling demonstration of PD behavior that is defined by the dominant strategy.

The extent to which prescriptive theory held for the single-play PD was not known, since there were no reported empirical studies of this situation. Instead, researchers had focused on the repeated-play PD, where large numbers of trials afford greater reliability, provide opportunity for applying stochastic models, and minimize the distorting effects of "warm-up" learning on early trial choices. Attempts have been made to show that the same one-play analysis also would hold for any extended series of repeated plays of the game and, in addition, the prescribed dominant choice would also be the unique equilibrium pair of strategies so that neither player would be motivated to alter this choice. There were no empirical results to substantiate these theoretical prescriptions; in all studies using repeated play, subjects apparently escape the dilemma in the repeated-play situation since they consistently achieve outcomes more favorable than those accruing to rational strategy.

Other theorists have argued that the "dominant" argument is considerably weakened for the repeated-play PD game and that an unequivocal normative basis for rational choice is not possible under these circumstances. This interpretation suggests that if the factors that weaken the case for the dominant choice were to be eliminated in the repeated-play PD, the prescriptive behavior would be obtained. The present study proposed to test this possibility by removing the trial-to-trial continuity of interaction between players--the resulting conditions of discontinuity should effectively preclude trust and influence; neither a past implication nor future

consequence may be carried from one trial to the next and rationally dominant play should obtain. Furthermore, a player under these conditions should prove indifferent to the number of competitive or cooperative responses that he encounters.

The critical experimental condition--repeated play without continuity of relationship between players--was practically feasible in a computer-based laboratory since the controlling software could readily administer an experiment to twenty-four participants concurrently; and they, in turn, could appreciate and accept the fact that they need not be interacting with the same other player from one trial to the next, if we had programmed the experiment to have them encounter one another on a chance basis (their adversary on each successive trial need not always be the same other person, but could be anyone of the other twenty-three participants in the experiment).

With the critical methodological condition thus satisfied the results afforded the first empirical demonstration that subjects would adopt the "nominally rational" strategy of persistent dominant choice. Furthermore, in this condition choice behavior was not markedly affected by the other player's strategy, i.e., subjects generally responded in accordance with the prescriptions of rational strategy that explicitly treat past experiences and/or current expectations as irrelevant to their choice. This was explicitly treated by a manipulation in which we simulated the "other" players' choices; two group postures were presented, one with 80 percent

dominant choices and another with 80 percent cooperative choices. The sheer frequency of encountered response did not provide a sufficient basis for altering behavior since subjects were not persuaded by the individually encountered majority example even when 80 percent of this majority chose a cooperative response.

(6) A Computer-Based Study of Perceived Relative Deprivation in a Growing, Class-Differentiated Society. A society requires some minimal level of cooperation of its citizens to function and grow. It is a disturbing phenomenon of the day that precisely at that point in time where the society increases its rewards to its relatively deprived citizens that they withdraw from active participation in the society and in many cases seek the disruption or total breakdown of the society.

Hypotheses such as rising expectations, relative deprivations, and distributive justice have been invoked to explain this kind of societal behavior.

Because of the complexities in administering and monitoring the interaction of a class-stratified group of sufficient size to assess these hypotheses in the laboratory, there are practically no experimental studies where the societal responses are treated as other than background constraints rather than as an interactive context or a set of dependent variables.

Three experimental variations of a societal game were run during the last quarter (Meeker and Shure, 1969a). The primary purpose

of these early runs was to establish baseline data concerning the minimal conditions sufficient to induce cooperative group behavior.

Basic condition: Each experiment involves ten subjects; they interact with one another, two at a time; the structure of the interaction is defined by the general logic of the Prisoner's Dilemma situation (mixed-motive, non-zero sum game); for each subject each successive interaction is with a different player drawn from the other nine subjects, and this "round-robin" mode of interaction is made apparent to the subjects through the experimental instructions. At any given point in the experiment there are five pairs of subjects interacting, though the membership of the pairs changes from one trial (interaction) to the next.

Social or collective conditions: The separate interactions are further characterized to the subjects in terms of group productivity. The index of group productivity is simply a count of the cooperative responses made within the group over a block of three trials. The rationale for this index follows from the non-zero sum logic of the interactions: from a collective point of view, the payoff is directly related to the number of cooperative responses; from an individual point of view, non-cooperative (defection) responses may, of course, yield greater payoffs, but this would be at the expense of the other person so that the net (collective) payoff would not be as great. The index of productivity is important to the subjects since if the group collectively reaches a criterion level of cooperation, then the payoffs for all subjects will be increased for the next block of trials.

Social class conditions: Each subject is assigned to one of three classes: Upper, Middle or Lower depending on an investment that each makes, independently, before the start of the game. The different classes are given different earning rates for payoff in the game, and their increments (applied when the group reaches criterion level of cooperation) are proportionally different.

Social context conditions: The basic condition of the game represents a minimal social context: there is almost complete anonymity among players--the only identifying information about the other person in a given interaction is his class membership; there is no collective communication--the only opportunity to exchange information is tacitly through the bargaining moves; there is no continuity of relationship among or between players--pairing are of a "chance" nature so influence cannot be meaningfully sustained; and there is prima facie absence of group norms and sanctions--without communication there can be no expression of group expectations, and with anonymity there can be no meaningful exercise of sanctions. Under these conditions the only formal (as contrasted with personal) inducement to cooperation is collective rationality, i.e., it is apparent that if everyone is cooperative, everyone will benefit; defection might yield some short-run gains, but the chances of sustaining short-run advantages while still maintaining a level of group cooperation high enough to achieve social growth are so improbable that rational considerations would favor a consistent posture of cooperation.

Results of the initial runs suggest that collective rationality is not a sufficient inducement to sustain cooperative behavior. Two variations with respect to payoff were tested; the matrices used were the following:

Matrix I

Player B

		Player B	
		Cooperative	Defection
Player A	Cooperative	A gets + 10 B gets + 10	A gets - 10 B gets + 15
	Defection	A gets + 15 B gets - 10	A gets - 5 B gets - 5

Matrix II

Player B

		Player B	
		Cooperative	Defection
Player A	Cooperative	A gets + 25 B gets + 25	A gets 0 B gets + 30
	Defective	A gets + 30 B gets 0	A gets + 5 B gets + 5

With a group using Matrix I, the criterion level of group cooperation was reached four times in twelve blocks of trials;

with group Matrix II, the criterion level was reached four times in eight blocks of trials--in other words, the first group achieved one-third its growth potential and the second group one-half. Defections from collective cooperation were not related to class membership; an Upper Class or Middle Class player was as likely to defect as a Lower Class player.

The third run in this initial series explored the effects of a selected social context condition, individual reputation. Operationally each player's reputation was represented in terms of the number of cooperative choices he had made in the previous three trials; this information was presented to the other player prior to each interaction; in all other respects this condition was the same as that which used pay-off Matrix II. The effects of providing reputation information were significant--the group achieved the criterion level of cooperation in every block of trials, i.e., the group achieved its full growth potential. Even so, there were fourteen defections over the course of the run; and most significant for the overall aims of the experiment, all but one of these were by players with Lower Class membership.

These results are not substantial enough to be interpreted in any but the most tentative terms, but they indicate that class differentiated behaviors can be induced experimentally; if this can be sustained in future runs it will afford us a unique opportunity to explore more definitive hypotheses regarding expectations, relative deprivations, distributive justice and social reaction formations to social defection behaviors.

2. SCENQUEST--A Scenario Questionnaire Technique for Studying In-Process Phenomena in Conflict Resolution.

Many in-process bargaining phenomena cannot easily be studied in experimental game situations because they occur rarely, or follow unique patterns of antecedent events, or require more extensive subjective analysis than can be easily obtained during the experiment. This approach, based on a combination of standard techniques, affords the experimenter a convenient, low-cost means of collecting data on a wide variety of situations that require control and standardization of antecedent events. An example of such a situation is a player's sudden shift to aggressive moves in a condition that had been stable and characterized by cooperation, and where no outside triggering event could be detected.

(1) General rationale. In the SCENQUEST approach, the experimental subject is given a specific ongoing situation or game. The synopsis may be described in dramatic, real-life terms or in bare-bone, analytical ones, and may concern such situations as a husband-wife confrontation, a prisoner's dilemma payoff matrix, etc. The synopsis gives a summary history of the events and decisions made by both parties, up to a given point. The subject reads the scenario from the point of view of one person in the situation; he is then asked to respond as if he were in the situation, in the designated person's place. He then records his response on a questionnaire form. This procedure contrasts with role-playing where a person is asked to adopt another's attitudes, opinions, etc. The respondent here is situation-playing.

(2) Developments. The initial SCENQUEST study has been designed to reassess the effects of different power relationships among potential coalition members as factors affecting preference of coalition partners and distribution of outcomes in preferred coalitions. Theories have emphasized the initial distribution of power (attribute power) and game-theoretic rational consideration (objective power) in predicting coalition formation. The results of experiments reported in the literature tend to support the former hypothesis more often in terms of coalition formation but fail to do so in terms of distribution of outcomes in these coalitions.

A number of different sets of materials were developed for this study and were administered in a carefully balanced design to six hundred under-graduates at Michigan State University during the autumn quarter of 1967. Independent variables include sex of subjects, initial distribution of power (4-3-2 versus 4-4-2), position of subject in power distribution (4, 3, or 2), objective vs. attributed differences in power distributions, contextual representation or scenario (union vs. business company merger contexts), and order of presentation of questions.

All dependent variables were analyzed by four- or five-fold analysis of variance procedures, or where these procedures were inappropriate, by χ^2 tests for independence. The results demonstrate that a number of the findings obtained in experimental studies of coalition games on sex differences and power position of subject are

also obtained in the paper-and-pencil SCENQUEST study. Furthermore, the significance of these findings is augmented by subjects' answers to questions designed to amplify motivations and perceptions related to preferred choices. These results and analyses are presented more fully in Terebinski, Shure, Kline, and Meeker (1968).

3. The Development of a Propositional Inventory of Attributes of American Character that may Influence American International Diplomacy and Negotiations.

In contrast to studies which have begun with the collection of empirical data (rating scales for attitudes, etc.), this research has begun with a situational study of American policy-making and negotiating behavior during diplomatic crises. It attempts to determine the general principles which motivate this behavior, on the basis of studies of these situations in their historical behavior, on the basis of studies of these situations in their historical context. A series of general statements, propositions, and hypotheses has been developed in the form of "Notes to a General Theory." The notes are in the form of a set of hypotheses regarding the characterological factors which influence American policy-making and negotiating behavior. A draft document has been completed for limited circulation. (Blanchard, 1968).

E. PLANS FOR A COMPUTER-BASED CENTER FOR BEHAVIORAL STUDIES

A significant effort during the last year of the contract was devoted to the design, phased development, and planned use of a new Center for Computer-Based Behavioral Studies (CCBS). Though not part of the critical project's program of research, this study was undertaken at the explicit request of Mr. Robert Taylor (then acting Head of ARPA Behavior Sciences).

A proposal was developed that describes the plans for the Center-- its design, phased development, and use. The center is to be designed around a time-shared computer system that will make its informational and technological resources available to behavioral scientists located at widely dispersed university and research centers, offering them new and powerful research, policy planning, and educational tools. A number of these tools for studying and analyzing the behavior of individuals, groups, and social-political units are specifically relevant to help bridge the enormous gap that continues to exist between the policy analyst, who faces the enormously complex and pressing social, political, and military problems of the times, and the behavioral scientist, who prefers to engage in those forms of research which yield more readily to reductionist theories and existing research techniques.

The proposal describes the basic concepts and purposes defining the proposed center, and the ordered stages of its development to achieve these goals. These are defined as three major areas of research and development activity:

- (1) The development of a behavioral studies laboratory program to break through some of the methodological limitations that currently threaten the viability of laboratory simulation for use as a tool in both theory building and policy study. A variety of laboratory techniques would be developed for using the computer as an experimental tool for on-line analysis, umpiring, controlling, and recording of decision making behavior, particularly the dynamic interaction process that takes place between players and teams of players. A primary focus of such development would be to provide support for complex, multiperson, international relation simulations, but the development would also include other simulation formats, simpler experimental situations, and other techniques as particular substantive issues are pursued.
- (2) The continued development of interactive computer data analysis systems (TRACE and IDEA). These programs offer a marked increase in investigator capability to intensively and flexibly scrutinize critically defined portions of large data bases. These tools hold promise of redefining the ground rules and relevance of an inductively oriented research approach in theoretically under-defined domains.
- (3) The development of an advanced data management and retrieval system and associated data repository to be based on the most advanced computer analysis and data management techniques, including new procedures for information retrieval and archive maintenance. Specifications for these requirements also would

be established by new assessments of the needs of behavioral scientists, policy analysts, and planners and by pilot studies on the way they utilized existing data archives in our developing system.

An essential concomitant to these broad areas of methodological and technical development is an on-going program of substantive research on bargaining and conflict resolution behavior relevant to political-military crises. While such research is important in its own terms, it also serves the broader perspective, both as a generating source for the definition of methodological needs and as an immediate test for the application of research tools. This interaction of substantive and methodological pursuits under the same program is considered optimal for the recursive and mutually beneficial interplay of expanding research objectives and improving methodological means.

Central to all of these activities are detailed plans based on a number of highly integrated software systems, hardware configurations, and laboratory design and equipment requirements. These plans are heavily based on ARPA-supported research and development projects conducted over the past six years. The entire set of requirements is set forth, along with detailed proposals for their realization (Shure, Meeker, and Cooperband, 1969).

PROJECT DOCUMENTATION

Blanchard, W. H. Notes on a theory of American character and its implications for bargaining and negotiating. SDC document SP-3200 (DRAFT), June 10, 1968. Revised as Chapter in American Policy and World Peace: A Study in Awareness. (In preparation).

Chadwick, R. W. A partial model of national political-economic systems: Evaluation by causal inference methods. SDC document TM-3989, June 25, 1968.

Cooperband, A. S. Initial TRACE III command language. SDC document TM-3624/000/00, September 19, 1967. 90 pp.

Cooperband, A. S., Moore, W. H. Jr., Meeker, R. J. and Shure, G. H. Basic TRACE III. Internal document, 1969.

Daniels, V. Communication and the sequence of action in dyads. SDC document SP-3201, June 11, 1968.

Daniels, V., Meeker, R. J. and Shure, G. H. Incentive, jeopardy, and a simple social contract in two-person interaction (DRAFT), 1969.

DeWeerd, H. S. An Israeli scenario for a laboratory simulation. SDC document SP-3139, March 21, 1968.

Esada, R. P. TRACE--Model II user's guide: Timeshared routines for analysis, classification and evaluation. SDC document TM-2621/003/00 (DRAFT), October 9, 1967.

Gold, Lois J. Swirsky. Personality, perceptions of the adversary, and plans to cooperate in a two-person, mixed-motive game. SDC document SP-3018, March 28, 1968.

Kelley, H. H., Shure, G. H., Deutsch, M., Faucheux, C., Lanzetta, J. T., Moscovici, S., Nuttin, J. M. Jr., Rabbie, J. M. and Thibaut, J. W. An experimental comparative study of negotiation behavior (DRAFT), June 1969.

McRae, J. World interest balances and nonresidential diplomatic accreditation. SDC document TM-4344, June 30, 1969. 33 pp.

Marsten, R. A description of IDEA: Part II. Mathematical aspects. SDC Memo-5, January 10, 1969a.

Marsten, R. A description of IDEA: Part III. A comparison with other multivariate techniques (DRAFT), March 1969b.

Meeker, R. J. and Shure, G. H. Updating some ground rules for man-machine simulation. SDC document SP-3143, April 25, 1968. Also published in Proceedings of the Seventh National Gaming Council Symposium on Gaming.

- Meeker, R. J. and Shure, G. H. Self-administered instructions for societal prisoner's dilemma games. SDC document TM-4450 (DRAFT), October 31, 1969a.
- Meeker, R. J. and Shure, G. H. Pacifist bargaining tactics: A laboratory assessment of some "outsider" influences. The Journal of Conflict Resolution, 1969b, 13, (in press).
- Mochson, M. S., Meeker, R. J. and Shure, G. H. RINAL--A program to analyze binary sequences. Behavioral Science, 1968, 13, 258-259.
- Press, L. I. IDEA: A technique for inductive data exploration and analysis, UCLA dissertation, September 15, 1967.
- Press, L. I. and Rogers, M. S. IDEA--A conversational, heuristic program for inductive data exploration and analysis, in Proceedings of the ACM National Conference, August 1967.
- Press, L. E., Rogers, M. S. and Shure, G. H. A strategy for man-machine symbiosis with a detailed example, (submitted to ACM Journal for publication), 1969a. SDC document SP-3267 (DRAFT).
- Press, L. I., Rogers, M. S. and Shure, G. H. An interactive technique for the analysis of multivariate data. Behavioral Science, 1969b, 14, 364-370.
- Shure, G. H., DeWeerd, H. A., Meeker, R. J., Carey, C. and Chadwick, R. W. Participant materials for "Simulation of a Middle East crisis 1973, Version I" for student participants. SDC document SP-3249 (DRAFT), October 10, 1968.
- Shure, G. H., DeWeerd, H. A., Meeker, R. J. and Carey, C. Participant materials for "Simulation of a Middle East crisis 1973, Version II" for faculty participants. SDC document SP-3249/000/01 (DRAFT), October 17, 1968a.
- Shure, G. H., DeWeerd, H. A., Meeker, R. J. and Carey, C. IR simulation record. Egypt. SDC document TM-4341/001/00 (DRAFT), November 4, 1968b.
- Shure, G. H., DeWeerd, H. A., Meeker, R. J. and Carey, C. IR simulation record. Israel. SDC document TM-4341/002/00 (DRAFT), November 4, 1968c.
- Shure, G. H., DeWeerd, H. A., Meeker, R. J. and Carey, C. IR simulation record. U.S.A. SDC document TM-4341/003/00 (DRAFT), November 4, 1968 d.
- Shure, G. H., DeWeerd, H. A., Meeker, R. J. and Carey, C. IR simulation record. U.S.S.R. SDC document TM-4341/004/00 (DRAFT), November 4, 1968e.
- Shure, G. H. and Kline D. The use of scenario questionnaire techniques (SCENQUEST) for studying real and perceived power differences in coalition formation. SDC document SP-3004, December 29, 1967.
- Shure, G. H. and Meeker, R. J. Bargaining and negotiation behavior technique progress report. SDC document TM-2304/101/00, October 23, 1967. 11 pp.

Shure, G. H. and Meeker, R. J. An empirical demonstration of normative behavior in the prisoner's dilemma, in Proceedings of the Seventy-Sixth Annual Convention of the American Psychological Association, 1968a, pp. 61-62.

Shure, G. H. and Meeker, R. J. Bargaining and negotiation behavior technique progress report. SDC document TM-2304/102/00, January 30, 1968b, 10 pp.

Shure, G. H. and Meeker, R. J. Bargaining and negotiation behavior technique progress report. SDC document TM-2304/103/00, May 30, 1968c, 10 pp.

Shure, G. H. and Meeker, R. J. Bargaining and negotiation behavior technique progress report. SDC document TM-2304/104/00, July 31, 1968d, 11 pp.

Shure, G. H. and Meeker, R. J. Bargaining and negotiation behavior technique progress report. SDC document TM-2304/105/00, October 31, 1968e, 12 pp.

Shure, G. H. and Meeker, R. J. A computer-based experimental laboratory. Administrative Science, 1969a, (in press).

Shure, G. H. and Meeker, R. J. Bargaining and negotiation behavior technique progress report. SDC document TM-2304/106/00, January 31, 1969b, 8 pp.

Shure, G. H. and Meeker, R. J. Bargaining and negotiation behavior technique progress report. SDC document TM-2304/107/00, April 30, 1969c, 13 pp.

Shure, G. H. and Meeker, R. J. Bargaining processes in experimental territorial conflict situations. Peace Research Society, 1969d, 8, (in press).

Shure, G. H., Meeker, R. J. and Cooperband, A. S. UCLA proposal for a center for computer-based behavioral studies: Its development and use, March 1969.

Shure, G. H., Meeker, R. J. and Hansford, E. A. The effectiveness of pacifist strategies in bargaining games. In Mueller, J. E. (Ed.) Approaches to Measurement in International Relations: A Nonevangelical Survey. New York: Appleton-Century-Crofts, 1969.

Shure, G. H., Meeker, R. J. and Hansford, E. A. The effectiveness of pacifist strategies in bargaining games. In Wertheimer, M. (Ed.) Psychology and Social Problems. Chicago: Scott, Foresman, 1970, (in press).

Shure, G. H., Meeker, R. J. and Moore, W. H. Jr. TRACE: Time-shared routines for analysis, classification and evaluation. SDC document TM-2469/004/00. Also published in Proceedings of Spring Joint Computer Conference, April 1967, pp. 525-529.

Shure, G. H., Meeker, R. J., Hansford, E. A. and Moore, W. H. Jr. De quelques voles joues par les calculatrices electroniques: Experimentateur, sujet, observateur. In Lemaine, Gerard and Lemaine, Jean-Marie (Eds.) Psychologie Sociale et Experimentation. Paris: Morton Press, 1969.

Shure, G. H., Press, L. I. and Rogers, M. S. Man-computer derivations of tree structures from multivariate data, in Proceedings of the Seventy-Sixth Annual Convention of the American Psychological Association, 1968, pp. 215-216.

Sillman, G., Meeker, R. J. and Bowman Sally. Computer-aided concept analysis: A case history in resource allocation using data base manipulation software, in Proceedings of the Fifth Annual Meeting of the American Institute of Aeronautics and Astronautics, 1968.

Terebinski, S. J., Shure, G. H., Kline D. and Meeker, R. J. SCENQUEST: A scenario questionnaire technique applied to the study of coalition formation. SDC document SP-3441, February 1968.

PROFESSIONAL AND PROJECT-RELATED ACTIVITIES

A. Presentations, Conferences, Meetings and Professional Liaison:

Rogers, M. S., Press, L. I. IDEA--A Conversational, Heuristic Program for Inductive Data Exploration and Analysis, National ACM Conference, Washington, D. C., August 29-31, 1967.

Rogers, M. S., Press, L. I. Inductive Data Exploration and Analysis (IDEA), Special Fall Meeting of the Psychometric Society in Washington, D. C. on September 1, 1967.

Shure, G. H. Fourth Transnational Conference on the Dynamics of Conflict, Sorrento, Italy, September 7-12, 1967.

Shure, G. H. On-Line Data Analysis for Studies in International Relations, at ARPA/IDA Symposium on Political Science Research, June 26-27, 1967.

Shure, G. H., Meeker, R. J., and Moore, W. H. Jr. Time-Shared Routines for Analysis, Classification, and Evaluation, Spring Joint Computer Conference, April 18-20, 1967.

Shure, G. H. New On-Line Computer Approaches to Psychological Diagnosis, Interviewing, and Data Analysis. UCLA Medical School, March 28, 1967.

Shure, G. H. Participant in Social Psychology Symposium on Commitment at UCLA, December 9, 1967.

Shure, G. H. Chairman of panel entitled, New Computer Development in Behavior Science Research, American Speech Association, Los Angeles, California, December 28, 1967.

Meeker, R. J. and Shure, G. H. Paper entitled, Negotiating with a Computer-Simulated Pacifist, American Speech Association, Los Angeles, California, December 28, 1967.

Shure, G. H. Consultant to observe and critique World Politics Simulation, Industrial College of the Armed Forces, Washington, D. C., January 22-23, 1968.

Shure, G. H. Paper entitled, Threat as a Variable in Bargaining Games, Social Psychology Seminar, Michigan State University, Lansing, Michigan, January 24, 1968.

Shure, G. H. Paper entitled, Methodological Hurdles to Theoretical Interpretations of Game Behavior, California Psychological Association, Santa Barbara, California, January 27, 1968.

Shure, G. H. Discussant in the International Politics Theory Symposium at the Center for Advanced Study in the Behavioral Sciences, Stanford, California, March 25-26, 1968.

Meeker, R. J. Participant in the West Coast Conference for Small Group Research, San Diego, California, March 27, 1968.

Rogers, M. S. Attended an initial meeting, March 27, 1968, of an ONR-sponsored group intended to discuss and share the latest developments in Pattern Recognition and Cluster Analysis.

Gold, Lois Swirsky. Paper entitled, Personality, Perceptions of the Adversary, and Plans to Cooperate in a Two-Person, Mixed-Motive Game, Western Psychological Association, San Diego, California, March 28, 1968.

Meeker, R. J., and Shure, G. H. Paper entitled, Pacifist Bargaining Tactics: A Laboratory Assessment of Some "Outsider" Influences, Western Psychological Association Meetings, San Diego, California, March 29, 1968.

Meeker, R. J., and Shure, G. H. Paper entitled, Updating Some Ground Rules for Man-Machine Simulation, National Gaming Council Symposium, Pacific Grove, California, April 28-30, 1968.

Shure, G. H. Briefing to members of Industrial College of the Armed Forces. Behavioral Gaming and Simulation Research Program at SDC, Santa Monica, California, May 1968.

Shure, G. H. Meeting with Dr. Claude Flament and Dr. Harold H. Kelley to interpret and plan the final write-up of the Transnational Bargaining Game, Aix-en-Provence, France, June 20-23, 1968.

Shure, G. H. Meeting with Dr. Claude Faucheux and Dr. Serge Moscovici to discuss and review translation of experimental bargaining research, Paris, France, June 28, 29, and July 1, 1968.

Shure, G. H. Meeting with Dr. Edgar Piret, U.S. Scientific Consular, American Embassy, Paris, France, June 28, 1968.

Briefing and consultation with Commander Joseph Benn and Colonel Robert Smith of the Joint War Games Agency to exchange experiences, methods, and techniques concerning geo-political-military simulations, August 2, 1968 (Behavioral Gaming Simulation staff).

Discussion with Thomas Schelling on gaming and simulation research, August 12, 1968 (Gerald Shure and Robert Meeker).

XVIth International Congress of Applied Psychology. Discussant on a symposium entitled "The Experimental Approach of Organizations," Amsterdam, Netherlands, August 18-22, 1968 (Gerald Shure).

Fifth European Peace Research Conference (International). Presentation entitled "Bargaining Processes in Experimental Territorial Conflict Situations," Budapest, Hungary, August 27, 1968 (Gerald Shure).

Presentation entitled "An Empirical Demonstration of Normative Behavior in the Prisoner's Dilemma," 1968 American Psychological Association Convention, San Francisco, California, August 30, 1968 to September 3, 1968 (Gerald Shure and Robert Meeker).

Presentation entitled "Man-Computer Derivations of Tree Structures from Multivariate Data," 1968 American Psychological Association Convention, San Francisco, California, August 30, 1968 to September 3, 1968 (Gerald Shure, Laurence Press, and Miles Rogers).

Fifth Transnational Meeting on Dynamics of Conflict. Presentation entitled "Unexplored Factors Influencing Subject Interpretations of Experimental Conflict Studies," Santa Rosa, California, September 2-7, 1968 (Gerald Shure).

Consultation and briefing with Colonel Thane Minor, ICAF, on simulation activities and techniques and possible participatory liaison between the ICAF Simulation and Computer Directorate and the Behavioral Gaming and Simulation staffs, September 23-25, 1968 (Behavioral Gaming and Simulation staff). Discussion focussed on the development of SDC type computer programs for on-line, multiperson simulation capabilities at ICAF and on the development and evaluation of an integrated program of simulation activities in support of the year-long ICAF curriculum.

Discussion with Gerald G. Barbacz, White House Fellow, DOD, to explore possible simulation exercise with White House fellows as participants, October 15, 1968 (Gerald Shure).

Meeting with Dr. Raymond Platig, U.S. Department of State, to set preliminary plans for November simulation, October 16, 1968 (Gerald Shure).

Presentation entitled "Computer-Aided Concept Analysis: A Case History in Resource Allocation Using Data Base Manipulation Software," Fifth Annual Meeting of the American Institute of Aeronautics and Astronautics, Philadelphia Civic Center, Philadelphia, Pennsylvania, October 21-25, 1968 (Gerry Sillman, Robert Meeker, and Sally Bowman).

Correspondence initiated by M. A. G. Knight, Scientific Affairs Division, NATO, to confirm a request for a visiting NATO behavioral scientist, Dr. Marisa Zavalloni, to study and work with the Behavioral Gaming and Simulation Program in Santa Monica, Spring 1969.

Communication with Nigel Forward, Ministry of Defense, United Kingdom, on potential use of IDEA- and TRACE-type programs in their ministry.

Arab-Israeli Simulation with participants from RAND and UCLA and USC faculties held at SDC, Santa Monica, November 4-6, 1968.

Arab-Israeli Simulation with participants from Departments of State held at ICAF in Washington, D. C., November 18-21, 1968. ICAF personnel on Colonel Thane Minor's staff served as nation monitors and military advisers to control.

Observation of Joint War Games Agency political-military game, ETA 1-68, in Washington, D. C., November 1968. Discussions with Colonel Charles P. Murray and Commander Joseph Benn (Gerald Shure).

Invited participant to RAND Seminar by Ambassador Yitzhak Rabin, Israeli's Ambassador to the United States, December 2, 1968 (Gerald Shure).

Research program briefly reported in December 2, 1968 issue of Newsweek.

Site visit to University of Southern California to review National Institute of Health Grant Request, January 29, 1969 (Gerald Shure).

Invited paper entitled "Bargaining Processes in an Experimental Territorial Conflict Situation" presented at the California State Psychology Association Meeting, January 31, 1969 (Robert Meeker and Gerald Shure).

Paper entitled "SCENQUEST: A Scenario Questionnaire Technique Applied to the Study of Coalition Formation" presented at the California State Psychology Association Meeting, January 31, 1969 (Terebinski, Shure, Kline, and Meeker).

Attended demonstration run of METRO simulation at University of Southern California, February 6, 1969 (Gerald Shure and Robert Meeker).

Demonstration and lecture of TRACE and IDEA at University of California, Santa Barbara, February 13, 1969 (Gerald Shure and Robert Meeker).

Invited address at Claremont Graduate School, "Computers in Behavioral Research," February 20, 1969 (Gerald Shure).

Seminar participant in Cross-Cultural Research at UCLA. Purpose: To discuss methodological and conceptual problems in cross-cultural and cross-national research, February 24, 1969 (Gerald Shure).

Meeting of ONR-Sponsored Pattern Recognition Working Group at SDC, Santa Monica, February 26, 1969 (Miles Rogers and Gerald Shure).

Invited address entitled "Simulation and the Psychology of International Relations," University of California at Los Angeles, March 5, 1969 (Gerald Shure).

Meeting with Ed Paxson at RAND on Political Military Gaming at RAND, Santa Monica, March 12, 1969 (Gerald Shure).

Attended Institute for Defense Analysis meetings held in Washington, D. C., on the role of quantitative behavioral approaches in political science to policy analysis, March 19-20, 1969 (Gerald Shure).

The Polis Laboratory: A Dedication Conference at the University of California at Santa Barbara, March 26, 1969 (Presentations by Gerald Shure and Harvey DeWeerd).

Observation of Joint War Games Agency, political military game, SIGMA-I-69, in Washington, D. C., April 17-18, 1969. Discussions with Colonel Charles P. Murray and Commander Joseph Benn (Gerald Shure).

Meeting with Dr. Eberhardt Rechtin, Director ARPA, April 18, 1969.

Inter-campus UCLA/UCSB/SDC computer-based Mid East Simulation Exercise, May 12, 14, 21, and 28, 1969.

RAND Conference on Intelligence Needs for National Security Decisionmaking, Santa Monica, California, June 18, 1969 (Gerald Shure).

Statistical Language Workshop sponsored by Russell Sage Foundation, San Francisco, June 23-25, 1969 (Gerald Shure).

Rutgers' Conference of ARPA-funded Quantitative Political Science Projects, June 30 to July 1, 1969 (Gerald Shure).

B. SDC Demonstrations, Briefings, and Consultations on TRACE, IDEA, and Computer-Based Laboratory Studies:

Mr. Robert E. Barraclough, Chief, Regional Plan Operations, Tri-State Transportation Commission.

Mr. James Haggerty, Autonomics Unit, and Mr. P. J. O'Donnell, Transduction Manager, IPC (Group Management), Ltd., England.

Dr. Eugene Gloye, Office of Naval Research, Pasadena, California.

Dr. Charles Harsh, Office of Naval Research, Boston, Massachusetts.

Dr. Joseph Daly, and Mr. George Heller, U.S. Bureau of the Census.

Mr. Robert Landau, U.S. Government.

Dr. John Laski, Imperial College, England.

Dr. E. M. Gherman, and Dr. John Shell, Director of Research, Allergan Pharmaceuticals.

Dr. Robert W. Marquardt, and Dr. Ralph B. Smith, University of Dayton.

Mr. M. A. Strauss, U.S. Bureau of National Highway Safety.

Mr. Robert V. Head, Dr. Marvin Mueller, Dr. Milton E. Terry, and Dr. Joseph M. Weir, National Traffic Safety Data Center.

Major Richard Forester, and Colonel Leroy Wenstrom, Air University, Aerospace Studies Institute, Maxwell Air Force Base.

Captain Gerald Norton, U.S. Navy, Rear Admiral Jack Appleby, U.S. Navy, Lt. General Leighton I. Davis, USAF, Captain James Forrest, U.S. Navy, Colonel William T. Minor, USAF, Colonel Frank Muller, U.S. Army, Colonel Kenneth S. Hitch, U.S. Army, Lt. Colonel Andrew Mosier, USAF, Mr. Victor Baran, Industrial College of the Armed Forces.

Seymour Cohen, M.D., Margaret Deane, Dr. John Goldsmith, Mr. Wayne Hale, Mr. Al Hexter, Mr. Norman Perkins, California State Department of Public Health.

Colonel William H. Lake, USAF, and Lt. Colonel Robert E. Hays, Jr., USAF, Scientific Advisory Board Staff.

Dr. Walter L. Deemer, Weapons Evaluation and Control Bureau, ACDA, Department of State.

Dr. Alexander L. Clark, National Academy of Sciences.

Dr. Anders Sweetland, Mr. Frank Denton, Dr. Harvey Averch, Mr. Anthony Russo, RAND Corporation.

Dr. Ethel Aginsky, Anthropology Department, Hunter College.

Dr. B. W. Aginsky, Anthropology Department, New York College.

Dr. Robert Leik, University of Washington.

Dr. George Miller, University of California, Los Angeles.

Mr. Jeffrey Ball, SRI.

Dr. J. E. Uhlener, Director, Behavioral Science Research Laboratory.

Cmdr. J. R. Ahern, USN, Cmdr. L. J. Buechler, USN, Lt. Col. B. J. Ellis, USAF, Col. W. T. Hannum, USA, Lt. Col. W. O. Hauck, USA, Cmdr. R. W. Kennedy, USN, Capt. J. W. Lipscomb, Jr., USN, Col. J. F. Matteson, USA, Col. J. F. McWhorter, USA, Lt. Col. T. D. Potter, USAF, Col. W. M. Sigler, Jr., USMC, Capt. J. C. Van Pelt, USN, and Capt. D. W. Whelan, USN, Industrial College of the Armed Forces.

Dr. Sidney Roslow, Director, and Mr. Alan Kline, Pulse, Inc.

Dr. Dove Vernin, Continental Research Institute, New York, New York.

Dr. Alan Harwood, Director of Community Research.

Dr. Ronal Brooke, Director of Research, Neighborhood Medical Care, Bronx, New York.

Margaret Deane, California State Department of Public Health.

Dr. Lowell Wayne, University of Southern California, Los Angeles, California.

Dr. Seymour Calvert, Dean, School of Engineering, University of California, Riverside.

Professor Henri Rouanet, University of Sorbonne, Paris, France.

Mr. K. R. Sivaramakrishnan, Chief, Manpower Resources Directorate, Institute of Applied Manpower Research, New Delhi, India.

Charlie Harsh, ONR, Boston.

Dr. Robert Miller, IBM Systems Architecture.

Dr. Donald Burnstine, IBM Development Laboratories.

Dr. Diane Ramsey, Reiss-Davis Child Study Center.

Col. Thane Minor, Director, Simulation and Computer Directorate, Industrial College of the Armed Forces.

Mr. L. A. Shackleton, Mr. F. J. Spencer, Mr. F. Fix, Dominion Bureau of Statistics, Ottawa, Canada.

Dermot W. Melick, M.D., Director, Arizona Regional Medical Program.

Dr. Robert DeGrasse, Vice President, and Dr. Roy Murphy, Research Director, Quantum Science Corporation.

Dr. A. A. Strand, Science Director, U.S. Naval Observatory.

Professor Eric Fromm, National University of Mexico.

Dr. Daniel Alpert, Dean of Graduate School, University of Illinois.

Dr. A. I. Fang, ABC News, Election Forecasting Research.

Dr. Stephen Lukasik, ARPA, Deputy Director.

Political Science, Psychology, Sociology, Computing Center staffs, University of California, Santa Barbara.

Cmdr. Joseph W. Benn, and Col. Wayne O. Hauck, Joint War Games Agency, Washington, D.C.

Professor Robert C. Noel, University of California, Santa Barbara.

Professor Dennis Sullivan, and Professor Edmund D. Meyers, Jr., Dartmouth College.

Dr. Ronald Jones, Professor of Urbanology, University of Missouri, Kansas City, Center for Studies of Mental Health and Social Problems.

Dr. E. L. Eichhorn, Jet Propulsion Laboratory.

Professor Trystram, and Mr. Patrice Bomard, University of Paris, French Planning Ministry.

September 1969

-107-
(Last Page)

TM-2304/108/00

Marisa Zavalloni, Associate Director, International Center for Intergroup Relations, Sorbonne University, Paris, France.

Bad Godesberg, and Klaus, Liepelt, Acting Chairman, DATUM, Germany.

Gideon Peri, Israeli Consul, Los Angeles, California.

Professor Peter Kammitzer, School of Architecture and Urban Planning, University of California, Los Angeles, California.

M. Balle, Director of Advanced Planning, Renault Company, France.

M. Bo, Manager, and M. Chevallier, Managing Director, Compagnie, Central d'etudes Industrielles, Paris, France.

Professor Al Chapanis, John Hopkins University.

Mr. James E. Miller, Director, Health Program System Center, Division of Indian Health Services.

Mr. Lawrence, Chief, Office of Evaluation and Development, Health Program System Center.

Colonel Peter Dawson, Director of Academic Plans and Research, USAF - ICAF.

Unclassified

Security Classification

DOCUMENT CONTROL DATA - R & D		
<i>(Security classification of title, body of abstract and indexing annotation must be entered when the overall report is classified)</i>		
1. ORIGINATING ACTIVITY (Corporate author) System Development Corporation Santa Monica, California		2a. REPORT SECURITY CLASSIFICATION Unclassified
		2b. GROUP
3. REPORT TITLE ON-LINE COMPUTER STUDIES OF BARGAINING AND NEGOTIATION BEHAVIOR: FINAL REPORT FOR CONTRACT DAHC15-67-C-0277, ARPA ORDER NO. 637/2.		
4. DESCRIPTIVE NOTES (Type of report and inclusive dates)		
5. AUTHOR(S) (First name, middle initial, last name) Gerald H. Shure Robert J. Meeker		
6. REPORT DATE September 1969	7a. TOTAL NO. OF PAGES 109	7b. NO. OF REFS 46
8a. CONTRACT OR GRANT NO. DAHC15-67-C-0277, ARPA Order No. 637/2	8b. ORIGINATOR'S REPORT NUMBER(S) TM-2304/108/00	
c. d.	8d. OTHER REPORT NO(S) (Any other numbers that may be assigned this report)	
10. DISTRIBUTION STATEMENT Distribution of this document is unlimited.		
11. SUPPLEMENTARY NOTES	12. SPONSORING MILITARY ACTIVITY	
13. ABSTRACT This research program was designed to lead to a set of empirically derived propositions on bargaining and conflict resolution behavior, and on processes that occur in situations where the parties involved have both common and conflicting interests--that is, where they are mutually dependent in the pursuit of otherwise antagonistic goals. Of particular concern were those issues and strategies in bargaining that appear to be relevant, actually or potentially, in political-military confrontations, particularly limited conflicts. This program involved five routes of development, and particularly the interaction and mutual support among them. 1. The design and use of international simulation methodology--both manual and computer based--for studies of IR theory and policy issues. The effort in this area was a distinct departure from our previous work but a logical extension of it--of computer and research methodologies to complex, multi-person, international relations games. We attempted to break through some of the methodological limitations that currently threaten the viability of such games for use as tools in both theory-building and policy study. 2. The development of software support for the computer-based laboratory. 3. The development of computer systems for data management and analysis. 4. On-line computer experiments in bargaining and negotiation. 5. Design and plans for a new ARPA supported Center for Computer-based Behavioral Studies. This final report, covering a period of two years, reviews the progress of this work.		

DD FORM 1473
1 NOV 68

Unclassified

Security Classification

Unclassified

Security Classification

14 KEY WORDS	LINK A		LINK B		LINK C	
	ROLE	WT	ROLE	WT	ROLE	WT
Bargaining Negotiation Behavior Conflict resolution International relations Data management On-line computer experiments						

Unclassified

Security Classification