

6

NRL Report 7013

AD 698282

Acoustic Characteristics of a Glass-Filament-Wound Pressure Vessel

A. MARK YOUNG
Measurements Branch

and

JOSEPH F. PRANDONI
Engineering Services Branch
Underwater Sound Reference Division

November 28, 1969



NAVY RESEARCH
CLEARINGHOUSE
P.O. BOX 1318
WASHINGTON, D.C. 20540

NAVAL RESEARCH LABORATORY
Underwater Sound Reference Division
P. O. Box 8337, Orlando, Florida 32806

This document has been approved for public release
and sale; its distribution is unlimited.

19

Contents

Abstract	ii
Problem Status	ii
Problem Authorization	ii
Introduction	1
The Vessel	2
Acoustic Transparency	2
Discussion of Results	5
Conclusion	7
References	8
Appendix A: Hydrostatic Pressure Test of Glass-Filament- Wound Vessel	11
Description of Vessel	11
Test Procedures	11
First Pressure Test	11
Second Pressure Test	12
Results	13
Computation of Volume	14
Modifications and Recommendations	14

Illustrations

Fig. 1. Section through glass-filament-wound pressure vessel	2
Fig. 2. Insertion loss, lower frequency range; c-w measurements with omnidirectional receiver	3
Fig. 3. Insertion loss; c-w signals, omnidirectional receiver	4
Fig. 4. Insertion loss, upper frequency range; pulsed measurements, omnidirectional receiver	5
Fig. 5. Insertion loss; pulsed signals, omnidirectional receiver	6
Fig. 6. Insertion loss, upper frequency range; pulsed measurements, directional receiver	7
Fig. 7. Insertion loss; pulsed signals, directional receiver	9
Fig. 8. Insertion loss as a function of pressure	10
Fig. A1. Setup for pressure tests	12
Fig. A2. Measured longitudinal strain and theoretical stresses and strains	13
Fig. A3. Measured elongation and volumetric expansion	13

Abstract

Acoustic insertion loss of a glass-filament-wound pressure vessel intended for transducer calibration varies significantly as a function of frequency, position, and hydrostatic pressure. The variations are believed to be due to voids in the glass-resin and in the glass-resin/rubber liner interface, which give rise to large changes in the characteristic impedance of the composite walls as a function of the same variables. Mechanical behavior of the vessel under hydrostatic pressure required a reduction of the specified maximum operating pressure from 2000 psig to 1000 psig.

Problem Status

This is a final report on one phase of the problem.

Problem Authorization

NRL Problem K03-30

Project RF 05-111-401-4470

Manuscript submitted 17 September 1969.

ACOUSTIC CHARACTERISTICS OF A GLASS-FILAMENT-WOUND PRESSURE VESSEL

Introduction

The Anechoic-Tank and Low-Frequency Facilities of the Underwater Sound Reference Division provide the capability for making acoustic measurements on underwater sound transducers at high hydrostatic pressure. Because the frequency ranges of the two facilities do not overlap, however, their calibrations can not be compared directly.

The characteristics of a glass-filament-wound pressure vessel have been investigated to determine whether it would provide such an overlap by permitting the calibration of transducers in the Lake (open-water) Facility at hydrostatic pressure equalling or exceeding that available in the Anechoic Tank. Such a vessel would be considerably less expensive than would additional steel tank facilities in the laboratory. The results of the investigation are reported here.

The Vessel

Generally, a vessel of the type considered consists of a central cylindrical section, or acoustic "window," closed by ellipsoidal ends. The center section is cylindrically wound of glass filament; the ends are geodesically wound. To prevent permeation of the glass-resin composite by water at high pressure, the interior surface of the vessel is protected by a rubber liner bonded to the wall; the exterior surface is treated with a compliant coating impervious to water.

A transducer is calibrated by placing it within the vessel, submerging the assembly in a large body of water, pressurizing the vessel to the desired value, and transmitting sound through the walls to or from a transducer outside the vessel.

The dimensions of the vessel acquired by USRD are shown in the engineering drawing, Fig. 1. The average thickness of the window is 0.57 in.; the stated pressure capability is 2000 psig for pressure cycles of 15 min maximum duration. The specified life of the vessel is 1000 pressure cycles over a period of 10 years.

A mechanical evaluation to insure pressure integrity and operating safety was conducted before attempting to evaluate the vessel acoustically. Results of the measurements made by the Engineering Services Branch are included as Appendix A.

Acoustic Transparency

If the vessel is to be used successfully, it must meet rigid requirements for acoustic transparency and the mechanical Q must be low, so that the resonance in water will be highly damped. The insertion loss through the window must be known as a function of frequency and of pressure; the loss about the circumference of the vessel must be uniform, so that directivity measurements on the transducers within the vessel will have meaning.

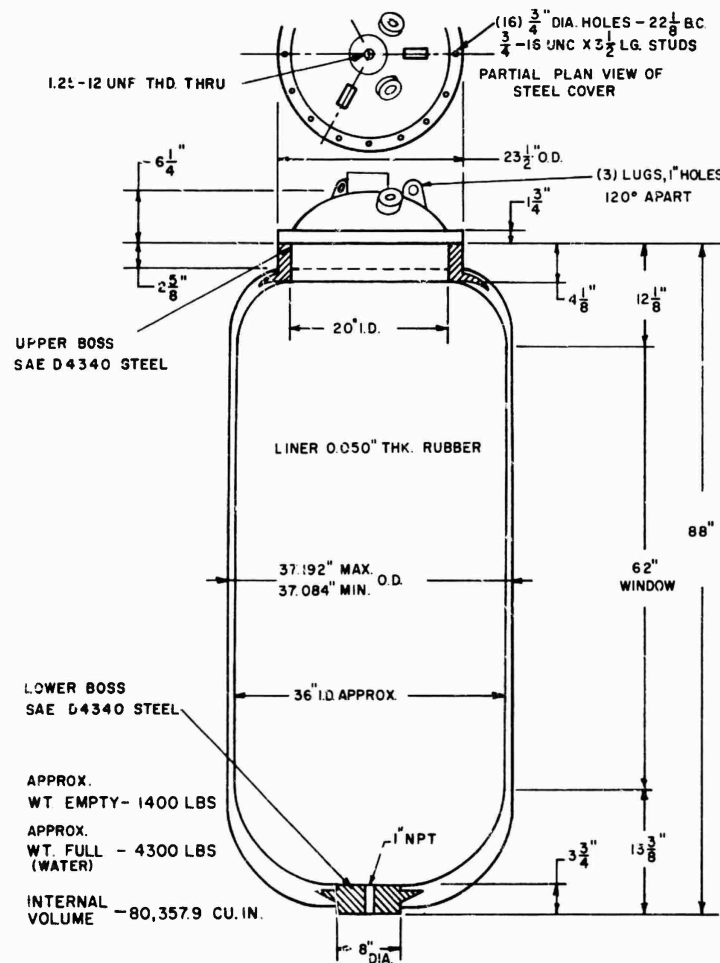

Fig. 1. Section through glass-filament-wound pressure vessel.

Because it was expected that the insertion loss would vary with frequency [1], measurements were made separately in two frequency ranges: (1) 0.1 to 10 kHz, where loss should be minimal because of the relatively low ratio of window thickness to wavelength; and (2) 10 to 150 kHz, where the loss would be expected to increase and become maximum at the frequency whose quarter wavelength in the vessel material equals the thickness of the window.

In the lower frequency range, the continuous-wave measurement technique was used; above 10 kHz, the pulsing technique must be used because of the increase in the amount of sound reflected from the walls. The vessel was rigged with its cylindrical axis vertical, and an arbitrary reference point was established on the circumference of the cylindrical section midway of its length.

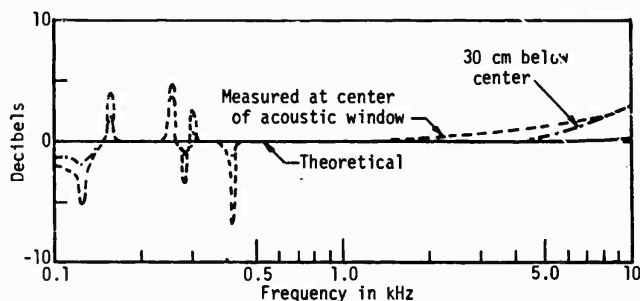

Fig. 2. Insertion loss, lower frequency range; c-w measurements with omnidirectional receiver.

Figure 2 shows the results of the measurements through the vessel wall at the reference point and 30 cm below it for frequencies below 10 kHz; the loss is considerably larger than had been expected. Figure 3 is a plot of the measured loss about the circumference of the vessel at various frequencies in both of the selected planes of measurement. An omnidirectional receiver was used. At 10 kHz and above, the pulse length is determined by the diameter of the vessel (36 in.), which allows 0.6 msec delay between receipt of the direct and the first reflected signal. The results of pulsed measurements along the two axes and about the circumference in the two parallel planes are shown in Figs. 4 and 5.

To allow the use of a longer pulse, the delay time was increased by replacing the omnidirectional receiver by a directional one. These results are shown in Figs. 6 and 7; the data shown in Fig. 7 were obtained with the directional receiver held stationary on a rod extending through the center in the top cover as the vessel was rotated about its vertical axis.

Because the receiver could not be held stationary while the vessel was rotated with pressure applied, an omnidirectional receiver with known pressure characteristics had to be used to evaluate the insertion loss of the vessel as a function of pressure. Pressure to 400 psig was sufficient to produce the change in loss characteristics shown in Fig. 8.

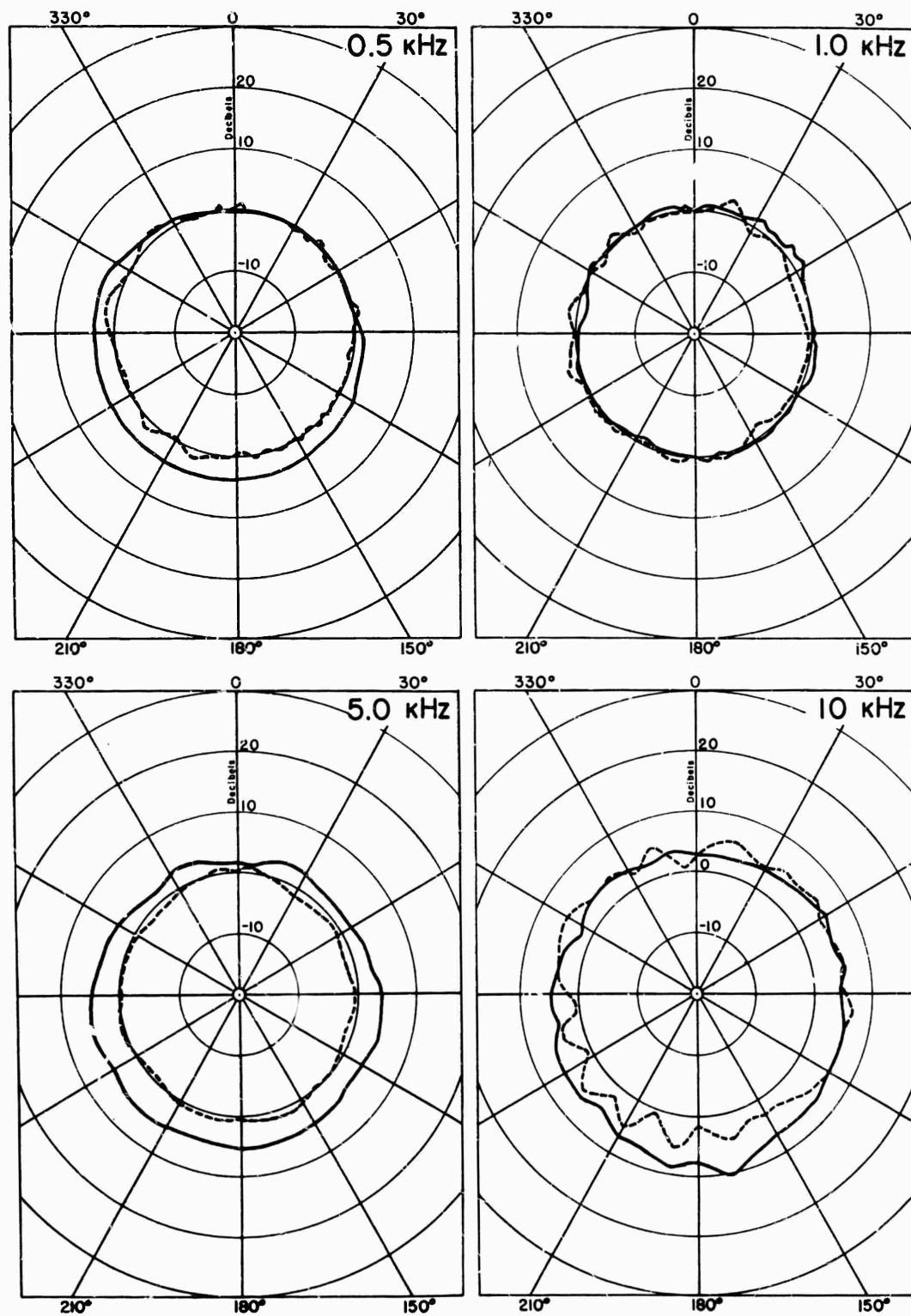

Fig. 3. Insertion loss; c-w signals with omnidirectional receiver. Solid: horizontal plane through center of acoustic window; dashed: parallel plane 30 cm below center.

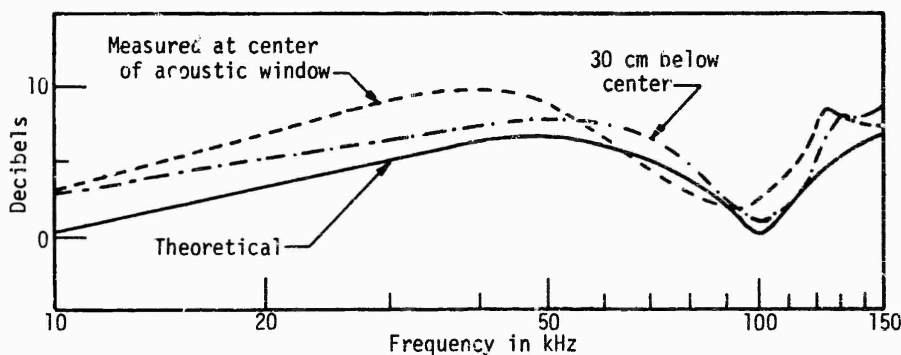

Fig. 4. Insertion loss, upper frequency range; pulsed measurements with omnidirectional receiver.

Discussion of Results

The frequencies of the resonance below 425 Hz were stable and repeatable; they did not vary appreciably with position of the receiver in the vessel. That they are the result of vessel resonance was confirmed by measurements made with an accelerometer attached to the body of the vessel.

The insertion loss through the window is not a simple function of frequency, position, or pressure. Below 10 kHz and above the frequency of highest resonance, the insertion loss increases uniformly with frequency, but in a different manner when measured along the reference axis and along the axis 30 cm below it. Although the values measured at frequencies above 10 kHz have been called "insertion loss," it is clear that the results (Figs. 4 through 7) depend on pulse length and directionality of the receiver and thus they probably are conditioned by reflections from within the vessel. Even the measurements of Fig. 6 obviously are functions of parameters other than frequency.

Change in insertion loss with pressure was minimal at the zero-degree reference; change with pressure as a function of position about the circumference, however, was quite pronounced, as indicated in Fig. 8.

Loss variations as large as those observed could result from (1) non-uniform thickness of the wall of the vessel, causing the frequency of maximum loss to change; or (2) nonuniform characteristic impedance of the composite (impermeable coating/glass-resin/rubber liner), causing the magnitude of loss to change. It is not likely that the wall thickness varies significantly from specifications (Appendix A), because it can be measured and controlled with reasonable accuracy during manufacture. If the dimensions of the vessel are within specifications, the frequency of maximum loss due to variation in wall thickness would shift by not more than ± 2.5 kHz from that shown in Fig. 4, but this would result in relatively small differences in loss at points around the circumference. It

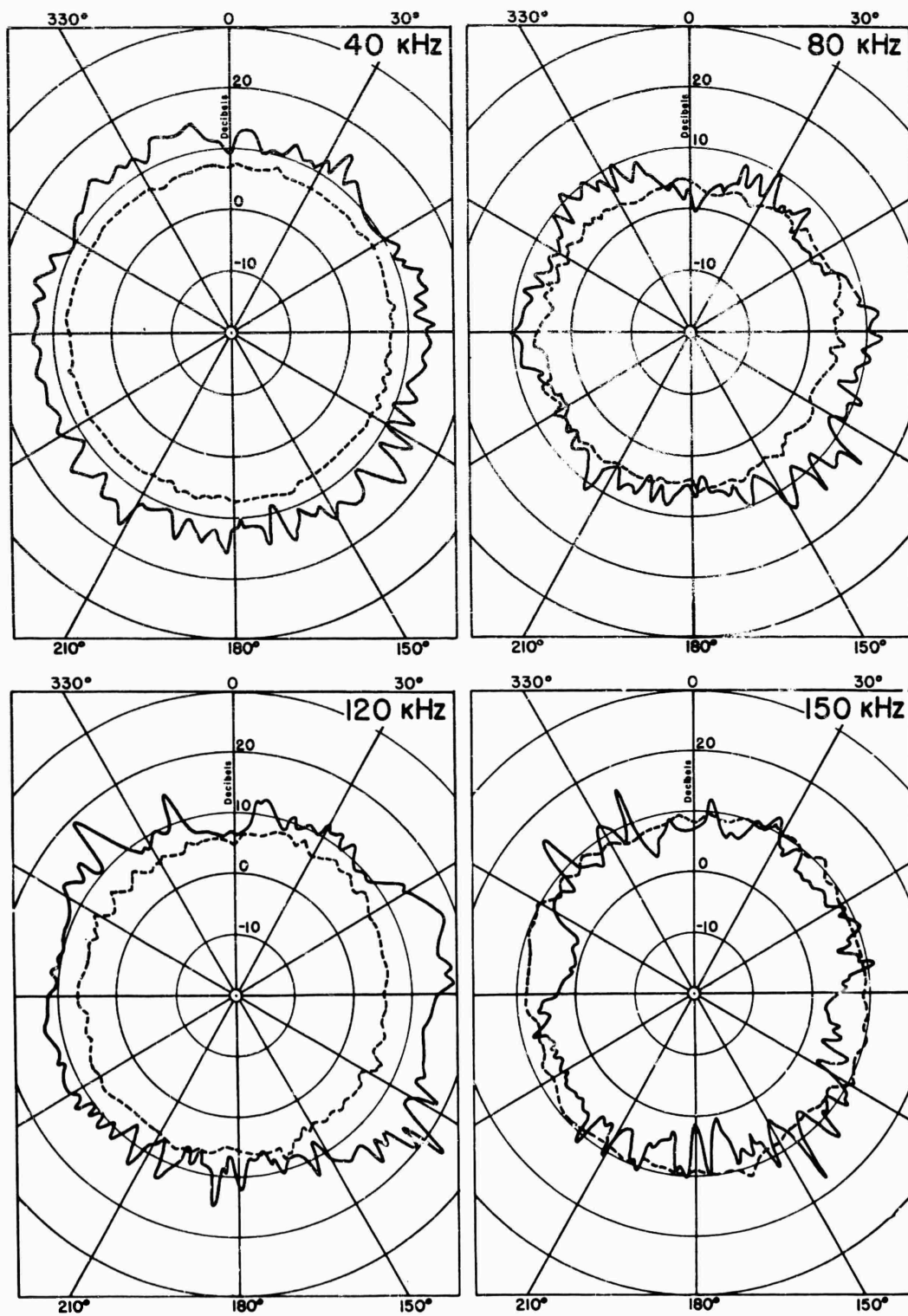

Fig. 5. Insertion loss; pulsed signals with omnidirectional receiver. Solid: horizontal plane through center of acoustic window; dashed: parallel plane 30 cm below center. Theoretical loss at 40 kHz: 6.0 dB; at 80 and 120 kHz: 3.7 dB; at 150 kHz: 6.4 dB.

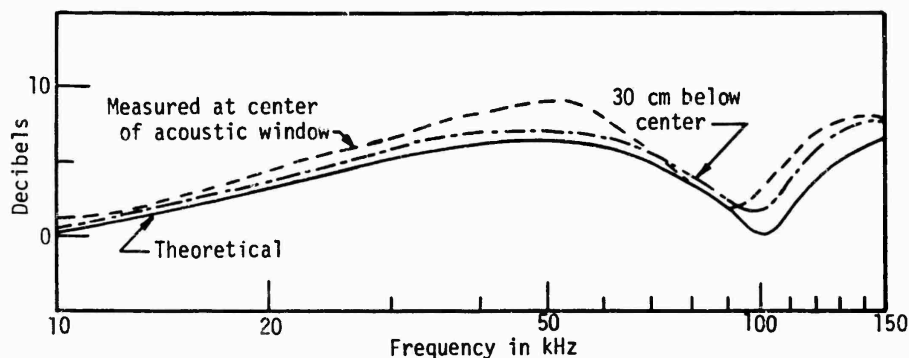

Fig. 6. Insertion loss, upper frequency range; pulsed measurements with directional receiver.

is more likely, therefore, that there are large changes in the characteristic impedance of the composite, caused by voids--specifically, voids in the glass-resin and in the glass-resin/rubber liner interface.

Although it is difficult to manufacture a void-free glass-resin composite [2], the problem in this particular case lies more logically in the interface. The patterns in Fig. 8 lend validity to this conclusion; voids in the interface can be displaced with pressure, thus effecting large changes in characteristic impedance at any given point and, therefore, changes in measured loss through the composite.

Success in the use of filament-wound vessels for calibration purposes has been reported [3,4], but several have failed under pressure. The Naval Undersea Research and Development Center, Transducer Evaluation Center, has reported failure by pressure of two such vessels.¹

Conclusion

The vessel evaluated is not suitable for use in calibrating transducers. Its failure to meet insertion loss requirements can be attributed to defective manufacture. It is probable that (1) the rubber liner is poorly bonded to the wall, or (2) high stress has caused cracks or voids to form in the glass-resin/rubber liner interface.

Presumably, the vessel evaluated in this report is identical to one used successfully by the Transducer Evaluation Center, Naval Undersea Research and Development Center. If this be so, it follows that the production of one usable vessel does not guarantee that it can be reproduced; conversely, the poor performance of the vessel at USRD should not automatically condemn others.

¹Related in discussions with NURDC TRANSDEC personnel in San Diego.

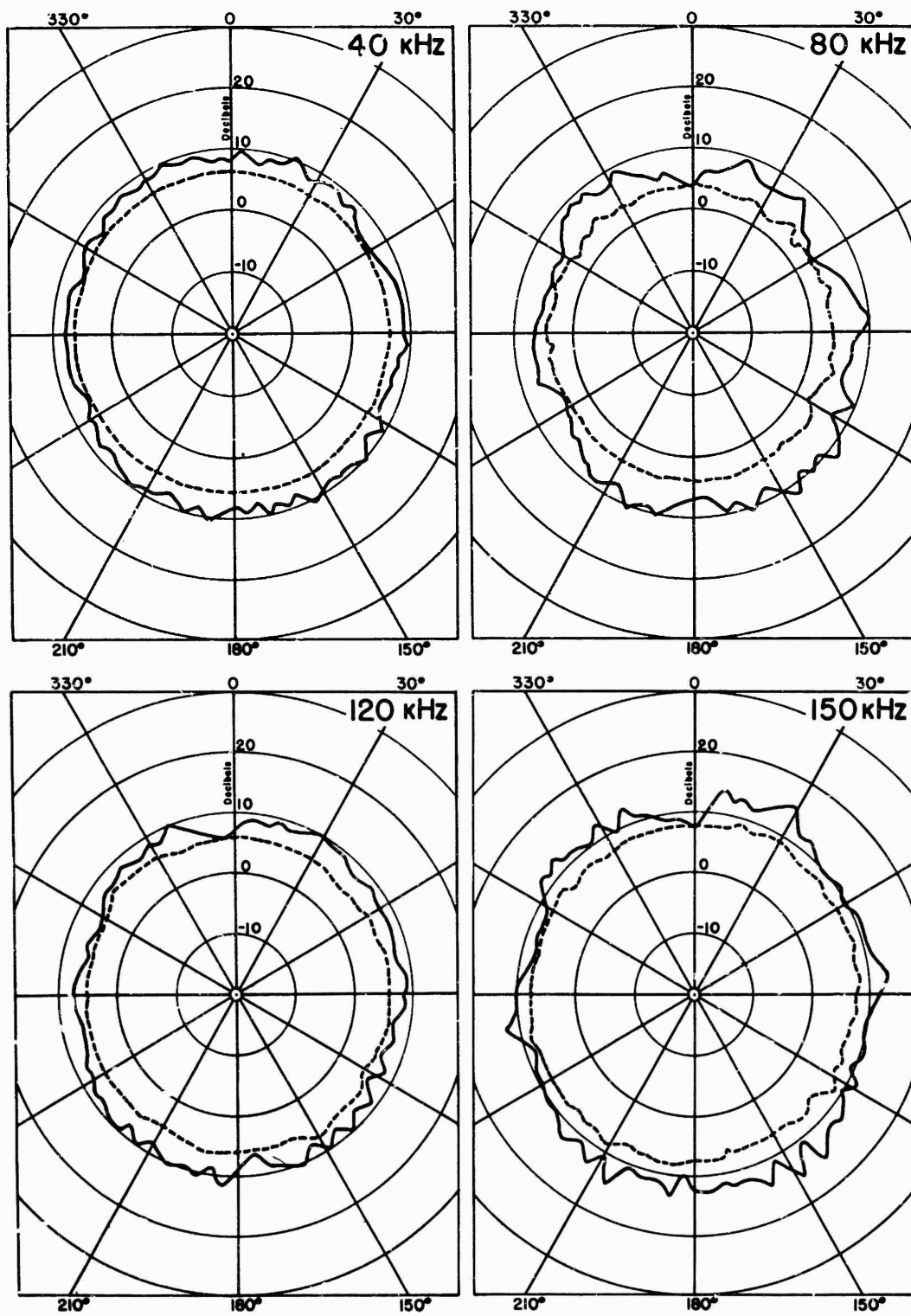

Fig. 7. Insertion loss; pulsed signals with directional receiver. Solid: horizontal plane through center of acoustic window; dashed: parallel plane 30 cm below center. Theoretical loss at 40 kHz: 6.0 dB; at 80 and 120 kHz: 3.7 dB; at 150 kHz: 6.4 dB.

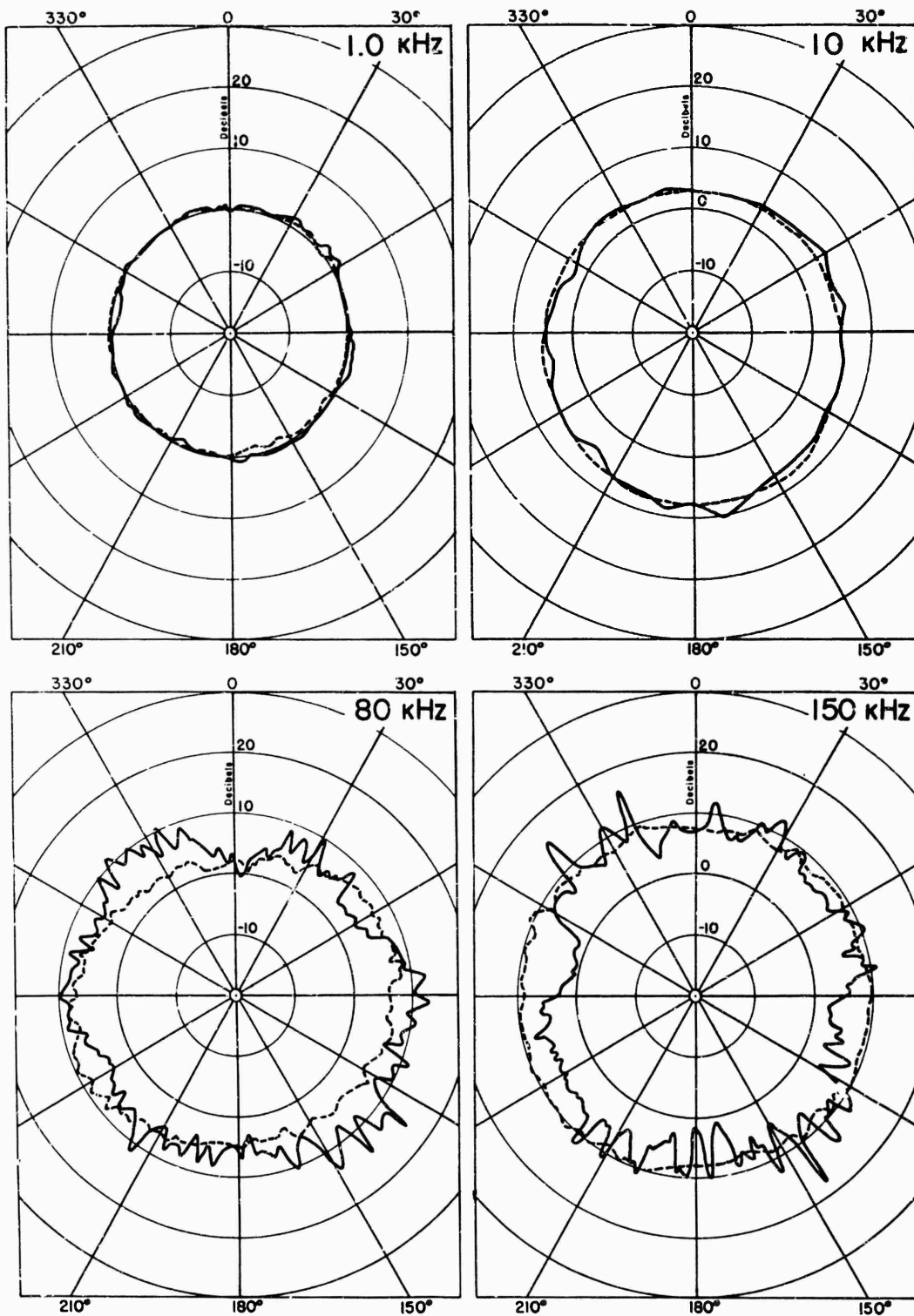

Fig. 8. Insertion loss as function of pressure; measured in horizontal plane through center of acoustic window with omnidirectional receiver. Solid: 0 psig; dashed: 400 psig. Theoretical loss at 80 kHz: 3.7 dB; at 150 kHz: 6.4 dB.

The techniques required to utilize a filament-wound pressure vessel successfully make it unsatisfactory for general use. For specific purposes, special procedures might permit efficient use. An increase in vessel size favors the technique by increasing the usable pulse length; but the increased size makes handling problems more difficult, and, for a given pressure, a larger vessel requires a greater wall thickness, with the accompanying increase in transmission loss and reflection levels.

Before the high unit calibration costs can be accepted, the high cost and limited life of the vessel, together with the risk of acquiring one with voids and manufacturing defects, make it necessary to show that there is no alternative.

References

1. L. E. Kinsler and A. R. Frey, *Fundamentals of Acoustics* (John Wiley and Sons, New York, 1950), pp. 149-154.
2. W. A. Zisman, "Surface Chemistry of Plastics Reinforced by Strong Fibers," NRL Report 6911, 14 May 1969.
3. C. E. Green, "Pressure Vessel for Calibrating Sonar Transducers," Naval Electronics Laboratory Report 1301, 26 July 1965.
4. C. E. Green, "Pressure/Temperature Vessels for Calibrating Sonar Transducers," Naval Undersea Warfare Center Report NUWC TP 45, May 1968.

Appendix A

HYDROSTATIC PRESSURE TEST OF GLASS-FILAMENT-WOUND VESSEL

Description of Vessel

The pressure vessel purchased by USRD (manufactured by Rohr Corporation, Riverside, California) is a 36-in.-i.d. cylindrical shell with ellipsoidal heads. The over-all length is 86.94 in. The upper head has a removable, O-ring-sealed, 20-in.-i.d. steel dished cover fastened by sixteen 3/4-in. 16 UNF×4-in. SAE 4340 heat-treated, high-strength-steel studs and nuts. Three lifting lugs and one 1 1/4-in. 12 UNF tapped hole have been provided in the upper cover. The metal boss in the lower head contains a 1-in. NPT hole. The cylindrical part of the shell is a composite of two layers of glass fiber bonded with an epoxy compound. The inner layer (0.254 in. max to 0.231 in. min thickness) is laid up of 6700 ends per inch helical winding interspersed with 9959 ends per inch hoop winding. The outer layer (0.342 in. max to 0.311 in. min thickness) also is laid up with the same helical and hoop winding pattern. The exterior of the vessel is coated with Epon 871 epoxy coating. The liner is 0.05-in.-thick MITCO No. 6520 rubber bonded to the glass fiber. The total thickness of the glass-fiber-resin wall can vary from 0.596 in. max to 0.542 in. min.

Test Procedure

The primary purpose of the hydrostatic test was to determine the expansion of the vessel with pressure and the maximum safe working pressure. The equipment setup is shown in Fig. A1. The initial internal volume of the vessel at atmospheric pressure was 80,358 in.³. The volume at a given pressure step was determined by carefully weighing the water pumped into the vessel, then slowly releasing pressure and recovering and reweighing the water. The longitudinal strain at pressure was read from the dial indicator attached to the upper end of the vessel.

First Pressure Test

Two series of measurements were made. The first proceeded without incident (except for sharp crackling noises from the vessel as pressure increased), cycling in 200-psi steps from 0 psig to the maximum pressure and then back to 0 psig, until the 20-in. cover joint started to leak as 1800 psig was approached. When pressure was reduced to zero, the 16 cover studs, which had been tight at the start of the test, were loose and had to be tightened. As pressure again was raised and reached 2000 psig, the O-ring gasket in the water connection fitted to the cover blew, and pressure fell rapidly. The tapped hole in the cover had expanded and

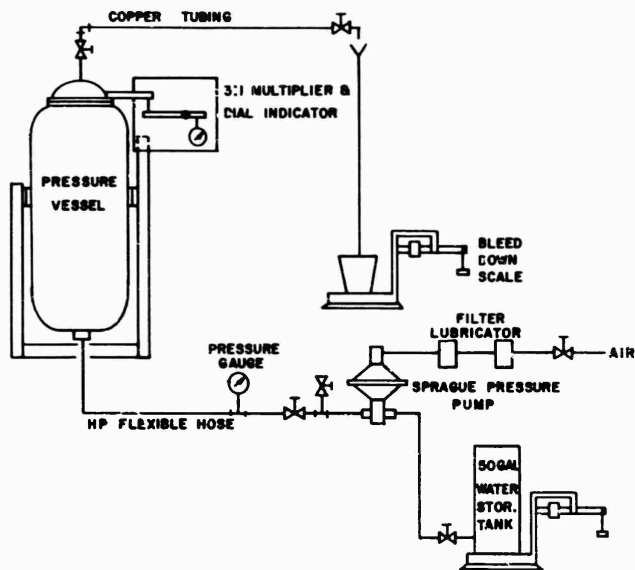

Fig. A1. Setup for pressure tests.

the threaded fitting no longer could be tightened and made leakproof. Examination of the painted internal surface of the cover revealed hair-line cracks in the paint similar to those obtainable with Stresscoat, indicating that the cover had been highly stressed at 2000 psig.

Apparently, the cover had been made from a 20-in. extra-strong, Tube Turn, Inc., welding cap that, according to the company's Catalog No. 111, should be 0.500 in. thick, but evidently had been machined to 0.400 in. thick. Calculation of the stresses in the cover at 2000 psig revealed that the meridian stress was about 41,600 psi, the hoop stress about 130,000 psi, and the crown stress, 49,200 psi. These are high values for ordinary carbon steels of ASTM A106 or ASTM A53, the usual materials for commercial piping components. These high stresses most likely accounted for the deformation of the cover and the leak at the water connection. To limit the deformation and to provide for cable glands, three steel bosses were welded to the cover as shown in Fig. 1 of this report.

Second Pressure Test

After the cover had been altered, the second test run was made in the same manner as the first had been. At the 1000-psig cycle, the plug in one of the cable gland bosses leaked. The pressure was reduced, the plug tightened, and the 16 stud nuts, which had loosened again, were retightened. Cycling continued, starting at the 1000-psig step. At the 1600-psig step, the cover seal again leaked. Examination revealed a thin "flash" of rubber on the O-ring where it had extruded between the faces of the flanges at the leak, indicating that the studs had undergone so much strain that they no longer could retain the O-ring.

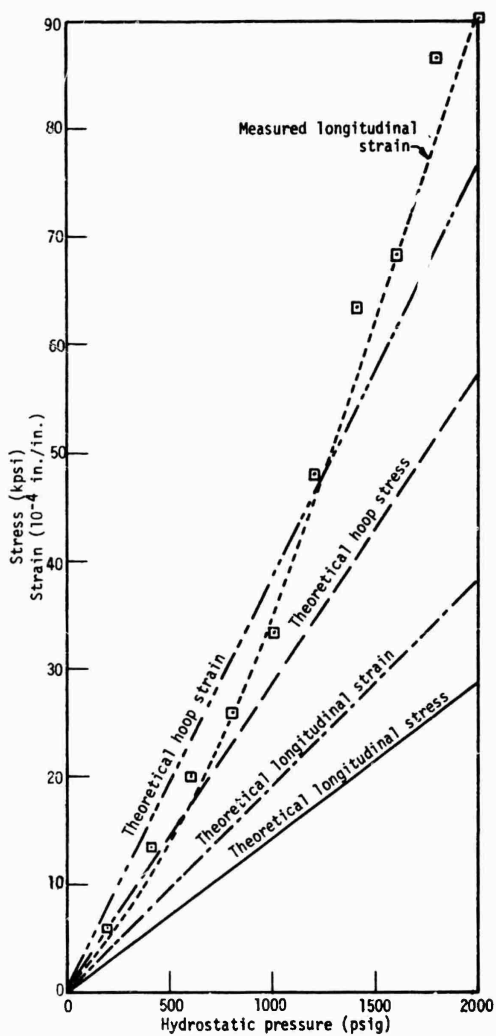

Fig. A2. Measured longitudinal strain and theoretical stresses and strains.

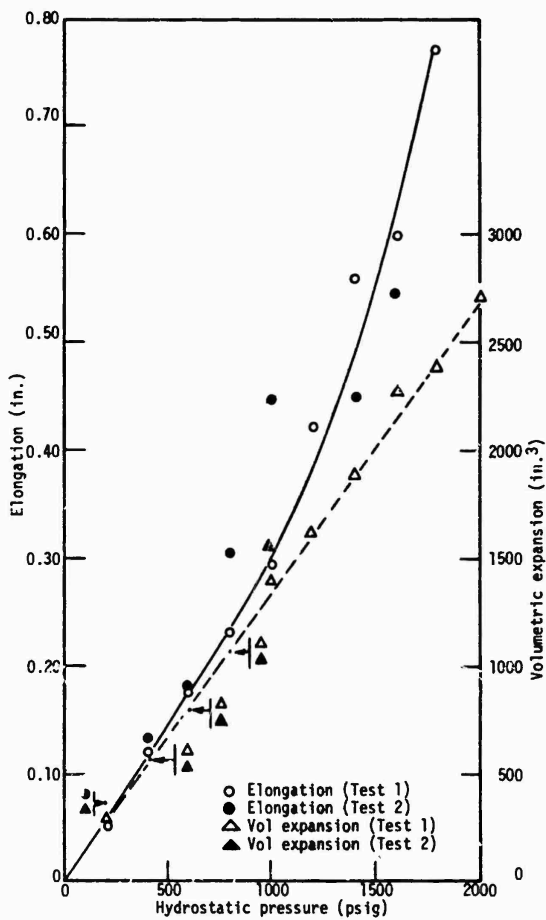

Fig. A3. Measured elongation and volumetric expansion.

Results

The calculated load on the cover at 2000 psig was 630,000 lb; the load per stud was 39,400 lb, corresponding to an elongation of about 0.004 in. This elongation does not appear to be excessive, but it was sufficient to permit the O-ring seal to extrude and the cover to leak. Results from the two test runs and theoretical calculations are shown in Figs. A2 and A3.

Computation of Volume

The enclosed volume was determined in two ways: (1) By calculation, using the design drawings with the offsets given for the upper and lower ellipsoidal heads. The volume of the upper head was 8276 in.³; that of the lower head was 8463 in.³; the volume of the upper collar was 1340 in.³, and that of the right cylinder or shell of the vessel between the heads was 61 600 in.³. The total calculated volume was 79,679 in.³. (2) From measurement of the quantity of water (347.88 gal) required to fill the vessel. The volume of the water was 80,360 in.³, which differs by less than 1% from the computed volume of the vessel.

Modifications and Recommendations

Before the vessel was released for acoustic measurements, the cover was strengthened by three steel reinforcing bosses welded at the cable gland and water connection openings. Material of 90 durometer was provided for the O-ring cover seal. To insure that the stress on the studs would be more reasonable and the cover joint would not leak, it was recommended that the maximum operating pressure of the vessel be reduced to 1000 psig.

DOCUMENT CONTROL DATA - R & D		
<i>(Security classification of title, body of abstract and indexing annotation must be entered when the overall report is classified)</i>		
1. ORIGINATING ACTIVITY (Corporate author) Naval Research Laboratory Underwater Sound Reference Division P. O. Box 8337, Orlando, Florida 32806		2a. REPORT SECURITY CLASSIFICATION UNCLASSIFIED
		2b. GROUP
3. REPORT TITLE ACOUSTIC CHARACTERISTICS OF A GLASS-FILAMENT-WOUND PRESSURE VESSEL		
4. DESCRIPTIVE NOTES (Type of report and inclusive dates) A final report on one phase of the problem.		
5. AUTHOR(S) (First name, middle initial, last name) A. Mark Young Joseph F. Prandoni		
6. REPORT DATE November 28, 1969	7a. TOTAL NO. OF PAGES 14 + ii	7b. NO. OF REFS 4
8a. CONTRACT OR GRANT NO. NRL Problem K03-30	9a. ORIGINATOR'S REPORT NUMBER(S) NRL Report 7013	
b. PROJECT NO. RF 05-111-401--4470	9b. OTHER REPORT NO(S) (Any other numbers that may be assigned this report)	
c.		
d.		
10. DISTRIBUTION STATEMENT This document has been approved for public release and sale; its distribution is unlimited.		
11. SUPPLEMENTARY NOTES		12. SPONSORING MILITARY ACTIVITY Department of the Navy (Office of Naval Research) Washington, D. C. 20360
13. ABSTRACT Acoustic insertion loss of a glass-filament-wound pressure vessel intended for transducer calibration varies significantly as a function of frequency, position, and hydrostatic pressure. The variations are believed to be due to voids in the glass-resin and in the glass-resin/rubber liner interface, which give rise to large changes in the characteristic impedance of the composite walls as a function of the same variables. Mechanical behavior of the vessel under hydrostatic pressure required a reduction of the specified maximum operating pressure from 2000 psig to 1000 psig.		

14. KEY WORDS	LINK A		LINK B		LINK C	
	ROLE	WT	ROLE	WT	ROLE	WT
Glass-filament wound construction						
Pressure vessels						
Transducer calibration facilities						
Acoustic windows						
Performance tests						
Insertion loss						