

AEDC-TR-69-216

MAR 4 1970

MAR 23 1995

Copy 2



SPECTROSCOPIC DETERMINATION OF TEMPERATURE IN A POTASSIUM-SEEDED AIR PLASMA

J. W. Gearhart

ARO, Inc.

February 1970

This document has been approved for public release and
sale; its distribution is unlimited.

**TECHNICAL REPORTS
FILE COPY**

**ROCKET TEST FACILITY
ARNOLD ENGINEERING DEVELOPMENT CENTER
AIR FORCE SYSTEMS COMMAND
ARNOLD AIR FORCE STATION, TENNESSEE**

PROPERTY OF U. S. AIR FORCE
AFCO LIBRARY
F40600 - 69 - C - 0001

NOTICES

When U. S. Government drawings specifications, or other data are used for any purpose other than a definitely related Government procurement operation, the Government thereby incurs no responsibility nor any obligation whatsoever, and the fact that the Government may have formulated, furnished, or in any way supplied the said drawings, specifications, or other data, is not to be regarded by implication or otherwise, or in any manner licensing the holder or any other person or corporation, or conveying any rights or permission to manufacture, use, or sell any patented invention that may in any way be related thereto.

Qualified users may obtain copies of this report from the Defense Documentation Center.

References to named commercial products in this report are not to be considered in any sense as an endorsement of the product by the United States Air Force or the Government.

SPECTROSCOPIC DETERMINATION OF TEMPERATURE
IN A POTASSIUM-SEEDED AIR PLASMA

J. W. Gearhart
ARO, Inc.

This document has been approved for public release and
sale; its distribution is unlimited.

FOREWORD

The work reported herein was sponsored by the Arnold Engineering Development Center (AEDC), Air Force Systems Command (AFSC), Arnold Air Force Station, Tennessee, under Program Element 65701F, Project 4344.

The work was conducted by ARO, Inc. (a subsidiary of Sverdrup & Parcel and Associates, Inc.), contract operator of AEDC, AFSC, under Contract No. F40600-69-C-0001. The work was conducted under ARO Project No. PL3912, in the 2-mw heater area of the Rocket Test Facility (RTF) during March and April 1968, and the manuscript was submitted for publication as partial result of this work on September 4, 1969.

The author wishes to acknowledge Messrs. W. K. McGregor and Ray A. Hefferlin for suggestions concerning this investigation and C. C. Limbaugh and G. R. Lynch for assistance with data processing.

This technical report has been reviewed and is approved.

Vincent A. Rocco
1st Lt, USAF
Research Division
Directorate of Plans
and Technology

Harry L. Maynard
Colonel, USAF
Director of Plans
and Technology

ABSTRACT

Spectroscopic measurements of radial electron excitation temperature distributions were made at the exit of a seeded, 2-mw arc heater. A nitrogen-oxygen mixture (about 3:1 in mass flow) was seeded with potassium carbonate. Potassium I lines were used in the determination of temperature by the ratio method. A modification to the ratio method was devised so that two different lines, observed under different conditions, could be correctly employed in the ratio method. The experimentally determined temperature profiles were nearly uniform across the plasma stream but varied in magnitude from run to run. Relative potassium I atom concentrations were nonuniform, but nearly radially symmetric, and exhibited an off-axis peak.

CONTENTS

	<u>Page</u>
ABSTRACT	iii
NOMENCLATURE	vi
I. INTRODUCTION	1
II. APPARATUS AND PROCEDURE	
2.1 Apparatus	1
2.2 Experimental Procedure	2
2.3 Calibrations	4
2.4 Data Processing	5
III. RADIATION EQUATIONS	
3.1 The Absolute Method	7
3.2 The Ratio Method	7
3.3 Application of the Absolute Method for K I Lines. . .	8
3.4 Application of the Line Ratio Method for K I Lines. .	8
IV. RESULTS AND DISCUSSION	
4.1 Measurements	10
4.2 Comparison of Measured with Calculated Temperatures	12
4.3 Discussion of Accuracy	13
V. CONCLUDING REMARKS AND RECOMMENDATIONS . .	14
REFERENCES	15

APPENDIXES

I. ILLUSTRATIONS

Figure

1. Arc Heater	19
2. Optics	20
3. Spectra Emitted by Potassium-Seeded Air Plasma. . .	21
4. Typical Raw Data	
a. K I 4965-Å Line	22
b. K I 5832-Å Line	23
5. An Axisymmetric Plasma	
a. Multizone Plasma	24
b. Three-Zone Plasma	25

<u>Figure</u>	<u>Page</u>
6. Typical Plots of Emission Coefficient versus Radius	
a. K I 4965-Å Line	26
b. K I 5832-Å Line	27
7. Emission Coefficient versus Temperature for Various Seed Concentrations	
a. K I 4965-Å Line	28
b. K I 5832-Å Line	29
8. Temperature versus Radius	
a. Pair 8, Left Hand	30
b. Pair 8, Right Hand	31

II. TABLES

I. Results of Temperature Measurements (°K) by the Ratio Method	32
II. Results of Temperature Measurements (°K) by the Intensity Ratio Application of the Ratio Method . . .	33
III. Calculated Values of Temperature (°K)	34

NOMENCLATURE

A_{nm}	Spontaneous radiative transition probability (Einstein's A)
c	Speed of light
c'	Constant, $A_{nm} g_n / \lambda$
C_λ	Calibration constant, $w / (\text{cm}^2 \text{ sr amp})$
C'_λ	Constant, $w / (\text{cm}^2 \text{ sr cm}_\lambda \text{ amp})$
E_n	Energy of atomic energy level n measured from ground state, eV
g_n	Statistical weight of atomic energy level n
H	Total enthalpy
h	Planck's constant
I	Denotes zeroth degree of ionization when written after element symbol, e.g., K I

$I_{\ell}(\lambda)$	Intensity of lamp at wavelength λ , $w/(\text{cm}^2 \text{ sr cm}_{\lambda})$
$I_0(y, \lambda)$	Integrated intensity emitted by an optically thin plasma at wavelength λ as a function of position y , $w/(\text{cm}^2 \text{ sr})$
k	Boltzmann's constant
N	Number of a particular species of atoms per unit volume
$N(r)$	Number of a particular species of atoms per unit volume at r
$R(y, \lambda)$	Response of system to radiation at wavelength, λ , when the system is positioned at y , amp
$R_{\ell}(\lambda)$	Response of system to standard lamp intensity, $I_{\ell}(\lambda)$, amp
r	Radius of the plasma stream (a variable quantity, $0 \leq r < r_0$), cm
r_0	Full radius of the plasma stream, cm
T	Temperature, °K
$T(r)$	Temperature at r , °K
$u(T)$	Partition function
$u[T(r)]$	Partition function at r [see Eq. (4)]
y	Distance in the vertical (spatial scan) direction, cm
β	Defined to be H_1/H_2 and is assumed to be T_1/T_2
γ	Ratio of specific heats
ϵ	Emission coefficient (intensity), w/cm^3
$\epsilon(r)$	Emission coefficient (intensity) as a function of radius obtained by an Abel transform operating on $I_0(y, \lambda)$
λ	Wavelength, cm
$\Delta\lambda$	Equivalent spectral bandwidth, cm

SUBSCRIPTS

- 1 K I 4965-Å run
- 2 K I 5832-Å run
- λ Identifies a dependence on wavelength

SECTION I INTRODUCTION

A study was made to (1) show the applicability of spectrometric diagnostic techniques for seeded, high enthalpy plasmas produced by large scale, high power, arc heaters, and (2) determine specifically from the spectral radiation the radial distribution of temperature at the exit of a seeded 2-mw arc heater, using a mixture (~3:1 in mass flow) of N_2 and O_2 as the working fluid, and K_2CO_3 seed, which was injected into the arc.

Photographic maps were made of the spectra of the plasma in the region from 3000 to 10,000 Å. Among the radiating species were K I, Na I, Cu I, and Zr I. No N_2^+ molecular bands were identified because of the heavy overlapping continuum radiation from K I. Of the radiative species present, it was decided to use the K I atomic lines in the determination of the temperature. The two particular lines chosen were selected to minimize self-absorption and self-reversal. It was assumed throughout that the plasma was optically thin for these two lines. Values of the radial electron excitation temperature distribution were found by making spatial scans across the plasma stream to obtain distributions of intensity of particular K I atomic lines as a function of the distance scanned. These intensity distributions were inverted by the Abel transform to determine emission coefficients for particular volumes on a radius of the stream. Comparison of the emission coefficients along with constants of the particular radiation system and correction for heater fluctuations from run to run allowed calculation of the radial temperature distribution by the ratio method. Absolute measurements of intensity were also made and could be used to find the density of the radiating species.

Temperatures were most reliably determined by the ratio method, and the temperature profiles across the stream were nearly uniform. Relative density distributions were nonuniform but nearly radially symmetric and exhibited an off-axis peak.

SECTION II APPARATUS AND EXPERIMENTAL PROCEDURE

2.1 APPARATUS

The arc heater used in this experiment was a Thermal Dynamics Model F-5000 having a zirconium insert in the cathode (Fig. 1, Appendix I, and Ref. 1). Gas was injected tangentially and flowed into a

1-in.-diam, water-cooled, copper anode section where it was heated in the arc and where the potassium seed was injected. The stream then entered a 3-in.-diam stilling chamber and flowed from the stilling chamber to atmosphere through a nozzle having a 1-in. exit diameter. The K_2CO_3 seed was injected perpendicular to the stream centerline through a 3/16-in.-diam port. The seeder consisted of an auger which fed the seed material to a cyclonic mixing chamber, from which the gas and seed material were blown through a flexible line to the injection port.

The spectrometer used for these measurements was a SPEX Model 1800 which is a 3/4-m Czerny-Turner instrument capable of use either as a spectrograph or as a monochromator. An EMI 6526B multiplier phototube, an amplifier, and an x-y recorder were used for photoelectric recording. I-N and 103-F Kodak[®] plates were used in making spectral maps from 3000 to 10,000 Å.

An optical traversing mechanism was fabricated to scan the plasma in a plane 1/8 in. from the face of the heater (Fig. 2). The light entered the protective box and passed through the collimator to mirror A. The collimator and mirror A were moved vertically to spatially scan the plasma stream. The light then passed to mirror B which directed it to lens L which focused it on the slit of the spectrometer. It was assumed that the small change in path length as traversing was done did not affect the radiative transfer properties of the system. The collimator consisted of a piece of ceramic tube with a 1.5-mm inside diameter.

The system was aligned by focusing a helium-neon laser at the exit slit of the spectrograph, centering the rectangular beam of light on the main collimating mirror and adjusting the wavelength of the spectrograph until maximum transmission out the entrance slit was obtained for the 6328-Å line. The laser beam then proceeded out along the field of view of the spectrograph. In this manner, it was possible to align the field of view of the spectrograph in the vertical and horizontal planes with respect to the heater. The collimator tube was positioned and aligned with the beam from the spectrograph. The scanning mechanism was operated, the beam position was checked, and any skew in the traversing mechanism was then eliminated by adjusting the system.

2.2 EXPERIMENTAL PRODEDURE

The arc heater was started with a high voltage, high frequency pulse, and stabilized within 20 to 30 sec. The arc was operated typically at 1000 v and 780 amp. The predicted conditions calculated from preset

gas flow and power settings were 2.5 atm pressure in the stilling chamber and nozzle exit static temperature of 2600°K. These conditions varied, however, because of the inability to accurately control power and flow conditions. The concentration of potassium injected was typically 0.0075 by weight.

During the first series of heater runs, photographic maps were made of the spectrum emitted by the seeded plasma stream.

The collimator was not used in making the photographic maps. The light from the plasma was reflected by the two mirrors (mirror A set at the stream centerline) and focused on the slit of the spectrograph. Exposures ranged from 1 min to 1/8 sec. A low-pressure mercury discharge lamp was used as a source for wavelength calibration spectra.

In the next series of runs, spatial traverses of the plasma stream were made. The traverses, made while recording the intensity of atomic spectral lines emitted by the plasma, were obtained in the following way:

1. The spectrometer was set to the wavelength of a K I line.
2. The traversing mechanism was set to the stream centerline.
3. The arc heater was started, and the wavelength control was adjusted slightly until the photomultiplier signal reached a maximum.
4. The traversing system was moved to the bottom edge of the stream.
5. A traverse was made across the stream.
6. The wavelength was shifted 5 \AA to a wavelength containing only continuum radiation, and another traverse was made to record the continuum radiation which was assumed to be equal to that at the wavelength of the line.

Each traverse took about 30 sec, and the entire run time was from 2 to 3 min, including heater stabilization. Because of the limitations of the heater system (maximum continuous operation 3 to 3.5 min) and the speed of the wavelength drive of the spectrometer, it was not possible to shift to another line and make two more traverses during the same run. Therefore, the traverses of different lines were made in separate runs in which it was attempted to obtain the same total enthalpy conditions. It was, however, not possible to set identical conditions.

Five runs were made on the K_{α} I line pair at 4965 Å, and five runs were made on the K I pair at 5832 Å. Typical raw data are shown in Fig. 4.

2.3 CALIBRATIONS

For intensity calibration, a tungsten ribbon filament standard lamp was set up on the centerline of the plasma jet and rotated to peak the output of the photomultiplier. In this position, the face of the ribbon was perpendicular to the line of sight as defined by the collimator and filled the field of view. With the standard lamp properly warmed up and operating at a calibrated current, the spectrometer was set at each of the line and continuum observation wavelengths, and the system responses (in units of amperes) were recorded on the x-y recorder. Since $I_{\ell}(\lambda)$ is known at the wavelengths of interest and since the response of the whole system, $R_{\ell}(\lambda)$ (in amperes of photomultiplier current), due to this lamp intensity can be observed and recorded, it is possible to define a calibration constant C'_{λ} for each wavelength in units of $w/(cm^2 sr cm_{\lambda} amp)$. Two calibrations were made at all the wavelengths of interest, and the calibration constants C'_{λ} given by both were averaged. The equivalent spectral bandwidth ($\Delta\lambda$ in cm_{λ}) of the system is defined to be the reciprocal dispersion of the spectrograph (cm_{λ}/cm) times the wider of the entrance and exit slit widths (cm). Both slits were the same width (50 μ) in this experiment. Since the dispersion of the SPEX 1800 was not constant over the wavelength region investigated, the dispersion was experimentally determined at 500-Å intervals, and values for the dispersion at the particular wavelength of interest were calculated and were used to determine the values of bandwidth. The system calibration constant C_{λ} is defined to be

$$C_{\lambda} = C'_{\lambda} \cdot \Delta\lambda \quad (w/cm^2 sr amp)$$

When $R(y, \lambda)$, the signal in amperes produced by the line radiation at the wavelength λ emitted by the arc heated gas stream, is multiplied by C_{λ} , then the intensity of the radiation from the plasma stream at wavelength λ appears in units of $w/(cm^2 sr)$. It was found that, when the calibration constant C_{λ} was calculated at the continuum measurement wavelengths (5 Å greater than the line wavelengths), it was significantly different from the values of C_{λ} at the line wavelengths because of the rapidly changing response of the system as a function of wavelength. Therefore, separate calibrations for the continuum observation wavelengths were also necessary.

2.4 DATA PROCESSING

The Central Computing Operations (CCO) IBM 360/50 system was used for all data processing. To prepare input data for computer processing, an average curve through the raw data (Fig. 4) was drawn by inspection for both the line and continuum traverses, and 50 points equally spaced on the y-axis were read from each of these curves. The input data were 25 points along each radius [$R(y, \lambda)$ in amp]. The values at these points were multiplied by the predetermined C_λ to obtain $I_O(y, \lambda)$, the intensity in $w/(cm^2 sr)$ from an optically thin plasma. The continuum intensity was calculated in a similar manner, and the continuum intensity was subtracted from the line intensity. In the computer program, the intensity values are fitted to a polynomial divided by a polynomial whose orders are controllable, and then the fitted data are plotted versus y. For these data, a fit was obtained with a fifth-order polynomial divided by a zeroth-order polynomial.

For this experiment, the quantity measured after calibration was intensity, $I_O(y, \lambda)$ [in $w/(cm^2 sr)$], as a function of the distance traversed across the plasma. This is an integrated measurement along the optical path and consists of contributions from regions which may vary in temperature and density. The desired measurement, however, is a point function measurement of the separate contribution of each of the elements along the optical path. Therefore, to find this desired quantity, which is the radiation per unit volume as a function of the plasma radius (emission coefficient $\epsilon(r)$), it is necessary to perform some mathematical operation on the data obtained.

In optically thin, axisymmetric plasmas, the intensity in terms of the emission coefficient is (Ref. 2)

$$I_O(y, \lambda) = 2 \int_y^{r_0} \frac{\epsilon(r) r dr}{(r^2 - y^2)^{3/2}} \quad (1)$$

where $I_O(y, \lambda)$ is the intensity in $w/(cm^2 sr)$ as a function of the distance y traveled in the vertical direction, r is the variable radius of the stream, and r_0 is the full radius of the stream. The inversion of this equation to solve for $\epsilon(r)$ is performed by use of the Abel transform and may be written

$$\epsilon(r) = - \frac{1}{\pi} \int_r^{r_0} \frac{I_O'(y, \lambda) dy}{(y^2 - r^2)^{3/2}} \quad (2)$$

Because of the derivative of $I_0(y, \lambda)$ in Eq. (2), small errors in $I_0(y, \lambda)$ may cause large errors in the determination of $\epsilon(r)$.

An approximate method of solving Eq. (2) is to write the integral [Eq. (1)] as a sum

$$I_j = r_0 \sum_{ij} a_{ij} \epsilon_{ij} \quad (3)$$

where a_{ij} is the shape factor (Ref. 3) for the area element being considered (Fig. 5a) and ϵ_{ij} is the emission coefficient of the plasma in that same area, where i labels the radius zones, and j labels the lateral path zones. Figure 5b illustrates a three-zone axisymmetric situation. For a three-zone axisymmetric case, the first equation that could be solved is that for the outermost radius zone:

$$I_3 = a_{33} \epsilon_{33} r_0$$

This equation can be solved for ϵ_{33} because a_{33} is given by the area and I_3 is measured. If the plasma is axisymmetric, then $\epsilon_{33} = \epsilon_{32} = \epsilon_{31}$. The next equation solved is

$$I_2 = r_0 [a_{32} \epsilon_{32} - a_{22} \epsilon_{22} + a_{32} \epsilon_{32}]$$

which can be solved for ϵ_{22} . Similarly, $\epsilon_{22} = \epsilon_{21}$ which allows solution for ϵ_{11} using the equation for I_1 .

In this experiment, the plasma radius was divided into 25 zones, and the computer used an amplified procedure similar to the one above to calculate the values of the emission coefficient for each zone. Figure 6 shows the emission coefficients (w/cm^3 sr) as a function of radius, which were obtained by inverting the typical raw data (Fig. 4) by the Abel transform.

SECTION III RADIATION EQUATIONS

Two methods of determining temperature of radiative plasmas by spectroscopic methods are considered here: the absolute spectral line intensity method, and the spectral line intensity ratio method.

3.1 THE ABSOLUTE METHOD

The absolute intensity method makes use of the radiation from only one spectral line. The equation for the emission coefficient from such an atomic line is

$$\epsilon(r) = \frac{hc}{4\pi} \frac{A_{nm} g_n}{\lambda} \frac{N(r)}{u[T(r)]} \exp \left[\frac{-E_n}{k T(r)} \right] \quad (4)$$

where

$$u[T(r)] = \sum_n g_n \exp \left[\frac{-E_n}{k T(r)} \right]$$

where A_{nm} is the spontaneous radiative transition probability (Einstein's A), λ is the wavelength of the line, $N(r)$ is the species density, $[u T(r)]$ is the partition function, E_n is the energy in eV of the upper atomic energy level from which the transition originates, k is Boltzmann's constant, and T is the temperature in °K. To solve for temperature from this equation requires knowledge of the species number density and the partition function. Conversely, if the temperature and the partition function are known, then the number density may be found.

3.2 THE RATIO METHOD

A second method of measuring the temperature is by the ratio method. If two lines are observed, under identical conditions, and their emission coefficients are expressed as a ratio, the result is

$$\frac{\epsilon_1(r)}{\epsilon_2(r)} = \frac{A_{nm1} g_{n1} \lambda_2 \exp \left[\frac{-E_{n1}}{k T(r)} \right]}{A_{nm2} g_{n2} \lambda_1 \exp \left[\frac{-E_{n2}}{k T(r)} \right]} \quad (5)$$

In this method, the number density and the partition function cancel, and the intensity measurements may be made on a relative scale, since it is only the ratio of the emission coefficients that is of interest. However, for the ratio method to be valid, the excitation conditions for the two lines must be the same; i. e., for plasmas in thermal equilibrium, the temperature of the plasma must be constant over the length of time necessary to measure the two intensities.

3.3 APPLICATION OF THE ABSOLUTE METHOD FOR K I LINES

Olsen (Ref. 4) has made equilibrium calculations for air plasmas which have small concentrations of potassium. By equilibrium, it is meant that local thermodynamic equilibrium was assumed to exist. To make the equilibrium calculations, an equation (Eq. 4) was used. By choosing a typical, relevant value of concentration (N) and temperature (T) from within the range of interest and calculating the partition function $[u(T)]$, the equation was solved for the emission coefficient (ϵ). Olsen's curves of emission coefficient versus temperature for various concentrations of potassium for the 4965-Å line pair and the 5832-Å K I line pair are shown in Fig. 7.

Therefore, if the value of N is known and ϵ is measured for either of these lines, then T may be found from Olsen's equilibrium calculations. It should be noted that the transition probabilities used in the equilibrium calculations were taken from theoretical calculations and that there is poor agreement between the few theoretical and experimental determinations of transition probability for K I. It should also be noted that there is no discernible difference between a temperature variation along the radius of the stream and a concentration variation (nonuniform distribution of the gross concentration) using the absolute method [see Eq. (4)].

3.4 APPLICATION OF THE LINE RATIO METHOD FOR K I LINES

The line ratio method involves finding the relative ratio of the emission coefficients of two lines and solving for the temperature. In this method, the number density and the partition function cancel, and the intensity measurements may be made on a relative scale. Solving Eq. (5) for the temperature gives

$$T(r) = - \frac{E_{n_1} - E_{n_2}}{K} \frac{1}{\ln \left[\frac{c'_2}{c'_1} \frac{\epsilon(r_1)}{\epsilon(r_2)} \right]} \quad (6)$$

For this particular case (the 4965-Å $8^2D - 4^2P$ and 5832-Å $5^2D - 4^2P$ K I line pairs), the transition probabilities compiled by Olsen (Ref. 4) are 3.90×10^5 and 3.20×10^5 (sec^{-1}), respectively, and Eq. (6) may be written

$$T(r) = -4.305 \times 10^3 \text{ }^\circ\text{K} \frac{1}{\ln \left[6.982 \times 10^{-1} \frac{\epsilon(r_1)}{\epsilon(r_1)} \right]} \quad (7)$$

These values of A_{nm} , compiled by Olsen, were derived from theoretical calculation. Knowledge of the transition probabilities of K I is at this time quite limited. Most of the values in the literature are based on theoretical calculations and are in poor agreement with the few experimental determinations that have been made.

The K I line pairs used here were chosen because their transitions end in upper energy levels. The radiation from these transitions is, therefore, much less likely to suffer self-reversal by "cool" parts of the plasma since it is unlikely that a significant part of the electron population would be in the 4^2P state.

For this investigation, the existence of a cool plasma layer is confirmed by the fact that the resonance lines of potassium at 7664.9 and 7669.0 Å are strongly self-reversed (Fig. 3). Even though the cool layer exists, the ratio method may be applied if the plasma is considered to be optically thin at the wavelengths of the lines used in the intensity ratio.

It must be noted that the assumption was made that the temperature and density at which the emission coefficients of the two lines were measured were the same for both measurements, although, in these experiments, the intensities of the two lines were measured in two different runs and, therefore, under different conditions. The emission coefficient for a particular atomic line may be written again:

$$\epsilon(r) = \frac{hc}{4\pi} \frac{A_{nm} g_n}{\lambda} \frac{N(r)}{u[T(r)]} \exp\left[\frac{-E_n}{kT}\right] \quad (4)$$

so that it can be noted that the only plasma variables affecting $\epsilon(r)$ are the temperature and density. If the temperature is uniform across the plasma stream, the ratio of the emission coefficient will be equal (at all r 's) to the ratio of the uninverted intensities (at all y 's) and will also be related to the temperature as in Eq. (6). This may be seen to be true if it is noted that

$$I_{o1}(y, \lambda) = \frac{hc}{4\pi} \frac{A_{nm1} g_{n1}}{\lambda_1} \int_y^{r_0} \frac{N_1(r)}{u[T_1(r)]} \exp\left[\frac{-E_{n1}}{kT_1(r)}\right] dz$$

and

$$I_{o2}(y, \lambda) = \frac{hc}{4\pi} \frac{A_{nm2} g_{n2}}{\lambda_2} \int_y^{r_0} \frac{N_2(r)}{u[T_2(r)]} \exp\left[\frac{-E_{n2}}{kT_2(r)}\right] dz$$

for two separate measurements at λ_1 and λ_2 . If it is assumed that T_1 and T_2 are both measured in isothermal plasmas and if it is assumed that $T_1 = T_2$, then

$$I_{o_1}(y, \lambda) = \frac{hc}{4\pi} \frac{A_{nm_1} \epsilon_{n_1}}{\lambda_1} \frac{\exp\left[\frac{-E_{n_1}}{kT}\right]}{u[T(r)]} \int_y^{r_0} N_1(r) dz$$

and

$$I_{o_2}(y, \lambda) = \frac{hc}{4\pi} \frac{A_{nm_2} \epsilon_{n_2}}{\lambda_2} \frac{\exp\left[\frac{-E_{n_2}}{kT}\right]}{u[T(r)]} \int_y^{r_0} N_2(r) dz$$

and

$$\frac{I_{o_1}(y, \lambda)}{I_{o_2}(y, \lambda)} = \frac{A_{nm_1} \epsilon_{n_1} \lambda_2}{A_{nm_2} \epsilon_{n_2} \lambda_1} \frac{\exp\left[\frac{-E_{n_1}}{kT}\right]}{\exp\left[\frac{-E_{n_2}}{kT}\right]} \quad (8)$$

[see Eq. (5)]. Therefore, if the temperature of a plasma stream is uniform across the stream, then temperature information may be obtained from intensity ratios. And, conversely, if $I_{o_1}(y, \lambda)/I_{o_2}(y, \lambda)$ at all y 's gives temperature values equal to those found from the ratio method at corresponding r [ratios of $\epsilon(r)$], then the plasma is isothermal. It should be noted that the assumption that $\int_y^{r_0} N_1(r) dz = \int_y^{r_0} N_2(r) dz$, which was made in deriving Eq. (8), is not necessarily a valid one for separate measurements and introduces errors both in the above reasoning and in the ratio method.

SECTION IV RESULTS AND DISCUSSION

4.1 MEASUREMENTS

If it is assumed that there is a uniform distribution of the gross concentration of the potassium in the plasma, then the absolute method may be employed to find the excitation temperature of the plasma. Olsen's curves (Fig. 7) were used along with the measured absolute emission coefficients (typical set shown in Fig. 6) to determine the excitation temperature for this particular set of data, and gave temperatures (averaged across the whole diameter) of 2330°K for the 4965-Å line and 2398°K for the 5832-Å line.

If it is assumed that $\int_y^{r_0} N(r) dz$ is the same for both runs (see Section 3.4), then the temperature may be found by the ratio method. The temperatures found by the ratio method using the typical emission coefficients (Fig. 6) gave a relatively uniform temperature distribution at about 1900°K. The difference in this result and that obtained from the absolute measurements was due to the violation of the assumption that the measurements, for the pair of runs shown in Fig. 6, were made under identical excitation conditions. This is evidenced by the two different temperatures obtained using the absolute method. It is interesting to note that the average temperatures obtained from the absolute method, for this pair of runs, were in nearly the same ratio as the total enthalpies at which the heater ran when the spectral data were recorded ($T_1/T_2 = 0.972$ and $H_1/H_2 = 0.973$).

The ratio method may be corrected, however, for the difference in enthalpy from run to run in the following manner: Let

$$\beta = \frac{H_1}{H_2}$$

If it is assumed that the specific heat of the plasma is constant in the temperature region from T_1 to T_2 , then

$$\beta = \frac{H_1}{H_2} = \frac{T_1}{T_2} \quad (9)$$

If this assumption is correct, then Eq. (5) may be corrected for enthalpy difference and becomes

$$\frac{\epsilon_1(r)}{\epsilon_2(r)} = \frac{A_{nm1} g_{n1} \lambda_2 \exp\left[\frac{-E_{n1}}{kT_1(r)}\right]}{A_{nm2} g_{n2} \lambda_1 \exp\left[\frac{-\beta E_{n2}}{kT_1(r)}\right]} \quad (10)$$

By using measured values of enthalpy, Eq. (9) can be solved for β , and $T_1(r)$ can be obtained from Eq. (10). $T_2(r)$ can then be obtained from Eq. (9). The β correction method assumes that the specific heat between T_1 and T_2 is a constant and that $N_1(r)/N_2(r)$ is unity. It does not depend on whether or not the distribution of the gross concentration is uniform along the radius; it requires only that the distributions, of the gross concentration of K I for the two different runs, be identical.

When the β correction is applied to the typical emission coefficient data shown in Fig. 6 (pair 8), T_1 is 2320°K and T_2 is 2387°K where T_1 and T_2 have been averaged over the whole diameter of the stream (Fig. 8 and Table I, Appendix II). Three other pairs of runs were selected, and the results of the ratio method temperature calculation using the β correction are also shown in Table I.

Temperature calculations were also made using measured intensity rather than the emission coefficients; that is, calculations used ratios of $I_0(y, \lambda)$ rather than $\epsilon(r)$. The results are shown in Table II. The uniformity of the values obtained from the noninverted calculations and their agreement with the inverted calculation temperatures (except near the center) confirm the observation that the temperature in the plasma stream was nearly uniform. The values of temperature calculated for the last three zones of the plasma (23, 24, and 25) are not included in the average values mentioned above or in Tables I and II. These values were removed because of inaccuracy in measurement at the very low intensities at the edge of the plasma and because of the errors inherent in the data processing at the edge of the intensity distribution.

The uniformity of the temperature distribution across the plasma stream implies that the emission coefficient distribution (e. g. , Fig. 6) is directly proportional to the K I concentration as a function of r . The concentration distribution is typically nearly radially symmetric and has an off-axis peak. It can then be concluded that, in the arc heater used, the gross concentration of K I atoms was not distributed uniformly throughout the plasma. This was not unexpected since the injection of the seed into the high velocity swirling gas stream might give such a distribution.

It would, therefore, be incorrect to determine temperature at various points along the radius from Olsen's equilibrium calculations (Fig. 7) using the gross concentration of K I atoms for $N(r)$ and the measured value of $\epsilon(r)$.

4.2 COMPARISON OF MEASURED WITH CALCULATED TEMPERATURES

Calculations of average static temperature at the nozzle exit were made by PWT personnel from the observed operating parameters and the thermodynamic properties of pure air by using an energy balance. These calculations gave the results shown in Line 1, Table III. After the measurements were made, it was found that the mixture of gases had not been the desired 80-percent N_2 , 20-percent O_2 (to simulate air)

but had been a 90-percent N_2 , 10-percent O_2 mixture. Recalculation by PWT of the average static temperature corrected for the different mass flow but which still assumed the mixture to be pure air is shown in Line 2, Table III. Correction of γ to more closely approximate the real mixture gave the results shown in Line 3, Table III.

The results of these calculations possibly indicate a systematic error in the average measured values of temperature found by the ratio method (Line 4, Table III). If such a systematic error is present, it is believed that the transition probabilities used in the ratio calculation would be the most probable cause.

The transition probabilities could have easily caused an error of this magnitude. If the ratio of the transition probabilities (in the ratio c'_2/c'_1) were larger only by a factor of about three, then the values of temperature found by the ratio method would agree with the real mixture, thermodynamic calculations. It is not unreasonable to think that the transition probabilities might be this much in error, since they were obtained from theory, not from measurement.

4.3 DISCUSSION OF ACCURACY

There are several reasons for the temperature data scatter and the discontinuity at the center [between left (top) and right hand (bottom) halves of the same run]. Some of these are:

1. A large amount of fluctuation exists in the K I line intensity during the data runs (see Fig. 4).
2. The averaged data curve drawn through the fluctuating recording (Fig. 4) could not be expected to be symmetrical even if the "true curve" were.
3. The computer calculated curve fit of the data curve is expected to be only approximate.
4. The computerized Abel inversion is only approximate and operating on the two halves of the nonaxisymmetric intensity approximation; it would be expected to give a center discontinuity in the emission coefficients. This leads to a discontinuity in temperature.

It should be noted that the apparent temperature discontinuity at the center observed in the temperature calculations (Table I) is absent in the noninverted calculations (Table II). The discontinuity noted in

the emission coefficients is due to the sensitivity of the transform to the differences in curve shape of a particular run between the left and right hand sides for the reasons mentioned above. All pair combinations of the ten runs made gave results similar to those listed.

SECTION V CONCLUDING REMARKS AND RECOMMENDATIONS

The general agreement of the electron excitation temperature and the gas temperature predicted from aerodynamic and thermodynamic considerations is one indication of thermodynamic equilibrium. The electron excitation temperature across the seeded plasma stream under all the conditions investigated was determined to be essentially uniform. The excitation temperature could not be defined by an average over the series of runs because of uncontrollably different run conditions. In every case, it was noted that there was an $N(r)$ (K I number density as a function of r) variation, which was symmetrical about the stream centerline and which had an off-axis peak.

The spectral line intensity ratio method was quite sensitive to the enthalpy of the plasma stream, which changed significantly from run to run. However, it was practical to make observations at two different enthalpies and to correct for the enthalpy difference. This correction could be made under the assumptions that the specific heat of the gas was not a function of temperature and that the number density distribution for the two cases were the same.

The problem which prevented comparison of data taken during different runs and, therefore, at significantly different conditions was purely a mechanical one and might easily be solved by modification of the monochromator wavelength drive. Additionally, it is recommended that, when it is desired to use the ratio method for this kind of source (nearly isothermal), simultaneous measurements be made of the radiation from the two lines. In this manner, radial distributions of intensity could be obtained under more nearly identical conditions.

Since the temperature distribution of this particular plasma was nearly uniform across its diameter, future spectroscopic measurements of this and other nearly isothermal plasmas may most accurately and conveniently be made by measuring the ratio of the intensities of the lines rather than by calculating the emission coefficients by the Abel transform and taking their ratio. In this way, the errors inherent in the approximation of the Abel transform and in the data processing are avoided.

It is recommended that experimental determination of K I transition probabilities be made. The existing values in the literature are largely from theoretical calculations, are in poor agreement with experiment, have large probable errors, and are incomplete.

It is also recommended that the cause of the large intensity fluctuations observed in the plasma be investigated. One suitable method to determine whether the fluctuations were caused by temperature or density fluctuations in the plasma would be simultaneous observation of two K I lines for use in the ratio method. Then, the phenomena responsible for the fluctuations (both spatial and temporal) could be identified, and their effects on the plasma considered. It might then be possible to identify, and, if desirable, find ways to eliminate, the mechanism generating the fluctuating phenomena. It is indicated from the present results that the temporal fluctuation is a density-dependent phenomenon.

REFERENCES

1. Garrison, G. W. "Electrical Conductivity of a Seeded Nitrogen Plasma." AEDC-TR-68-116 (AD672249), July 1968.
2. Greim, H. R. Plasma Spectroscopy. McGraw-Hill Book Company, New York, 1964.
3. Pearce, W. J. Optical Spectrometric Measurements at High Temperatures. (Philip J. Dickerman, Editor). University Press, Chicago, 1961.
4. Olsen, H. N., et al. "Development of Diagnostic Methods for Seeded Air and Nitrogen Plasmas." AEDC-TR-68-217 (AD679530), December 1968.

APPENDIXES
I. ILLUSTRATIONS
II. TABLES

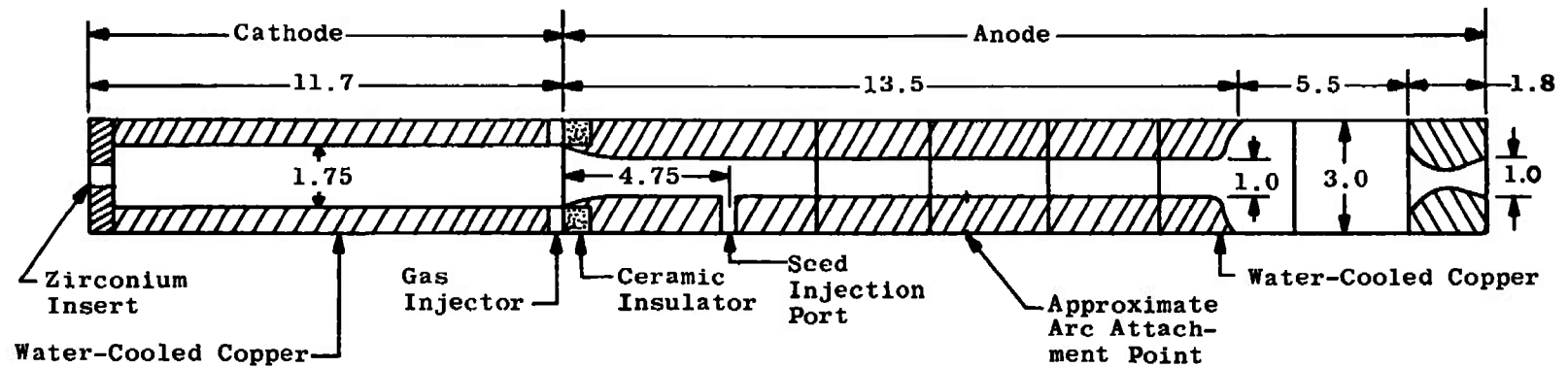

Nozzle Length	1.8 in.
Exit-to-Throat Area Ratio	1.37
Throat-to-Exit Distance	1.55 in.
Radius of Throat	0.426 in.
Exit Diameter	1 in.

Notes: This Drawing Not to Scale
All Dimensions in Inches

Fig. 1 Arc Heater

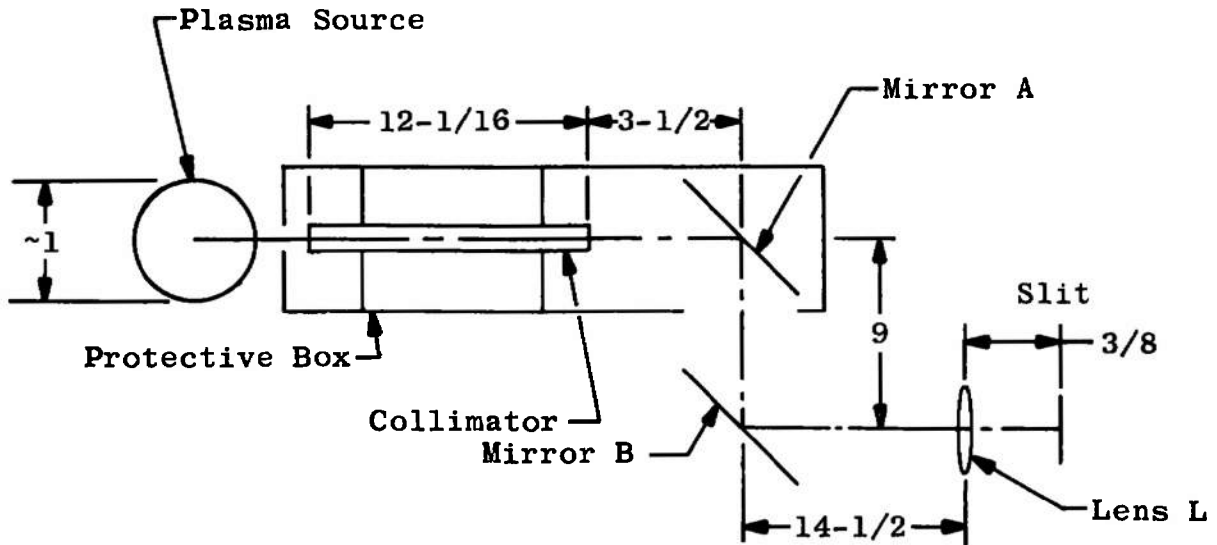

All Dimensions in Inches

Fig. 2 Optics

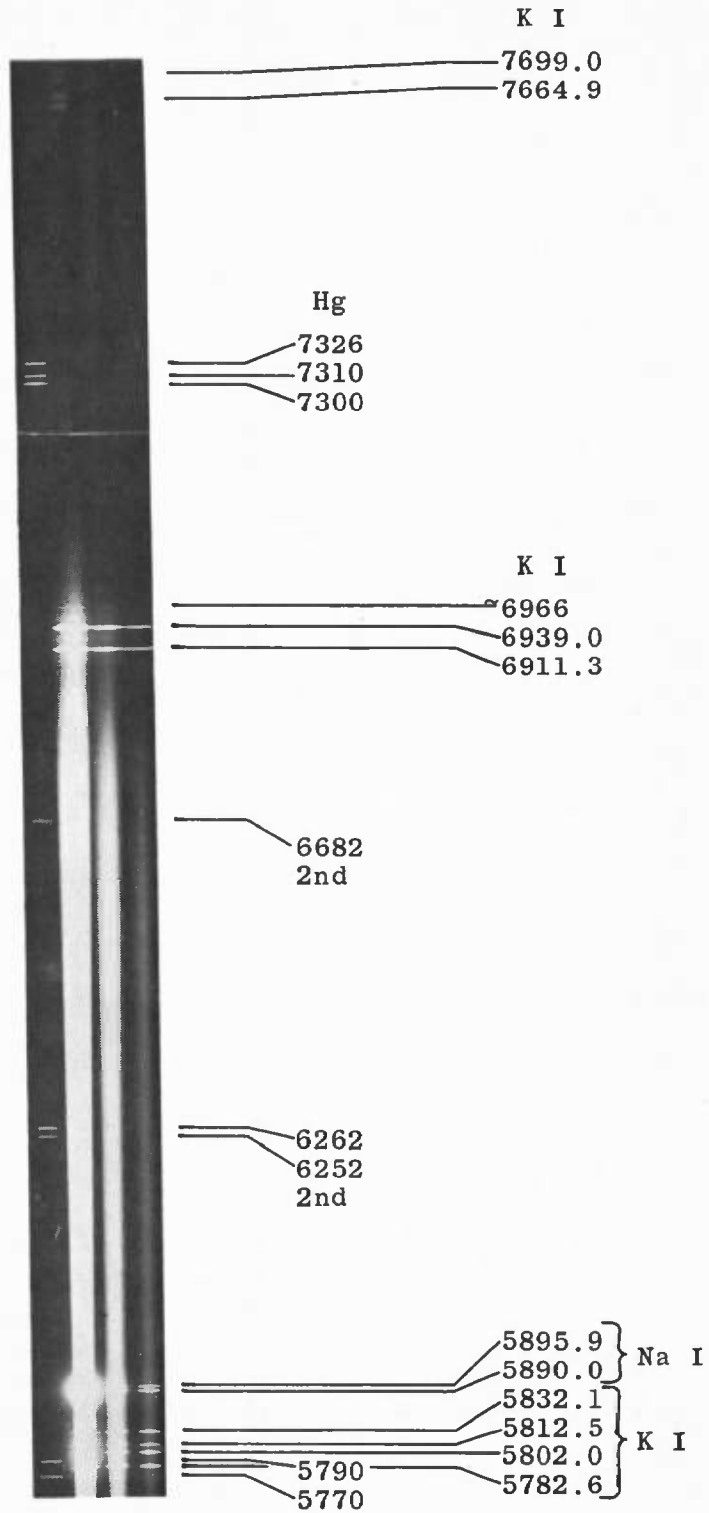
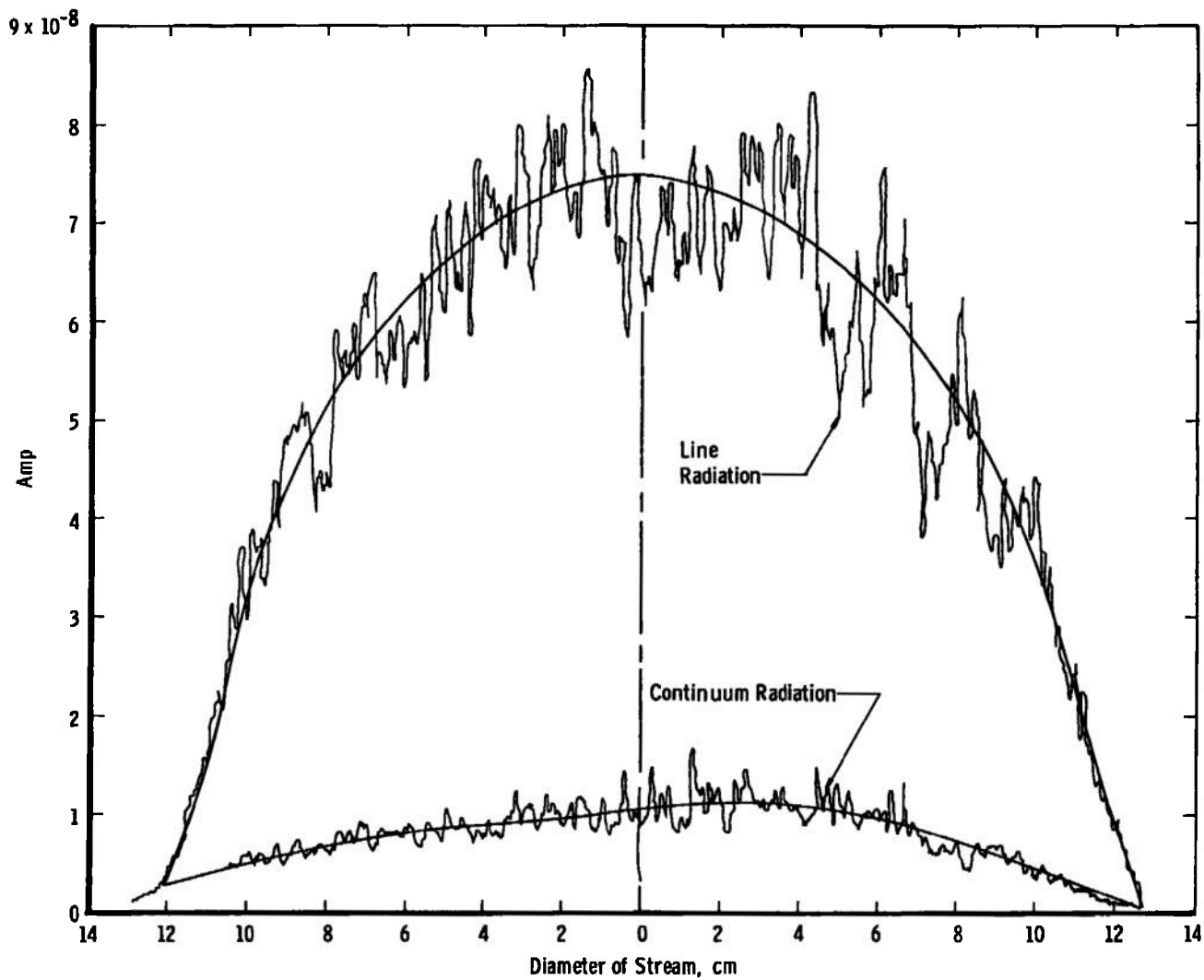
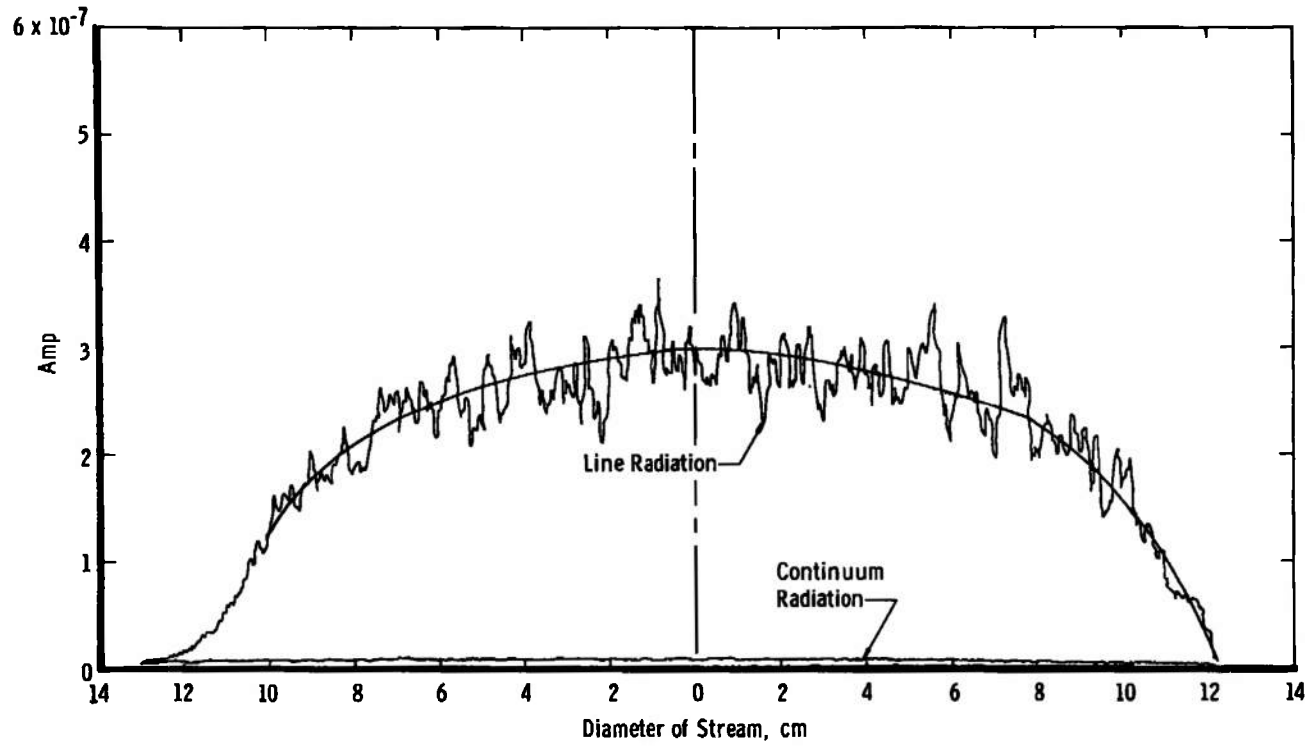

Fig. 3 Spectra Emitted by Potassium-Seeded Air Plasma



a. KI 4965-Å Line

Fig. 4 Typical Raw Data



b. K I 5832-Å Line
Fig. 4 Concluded

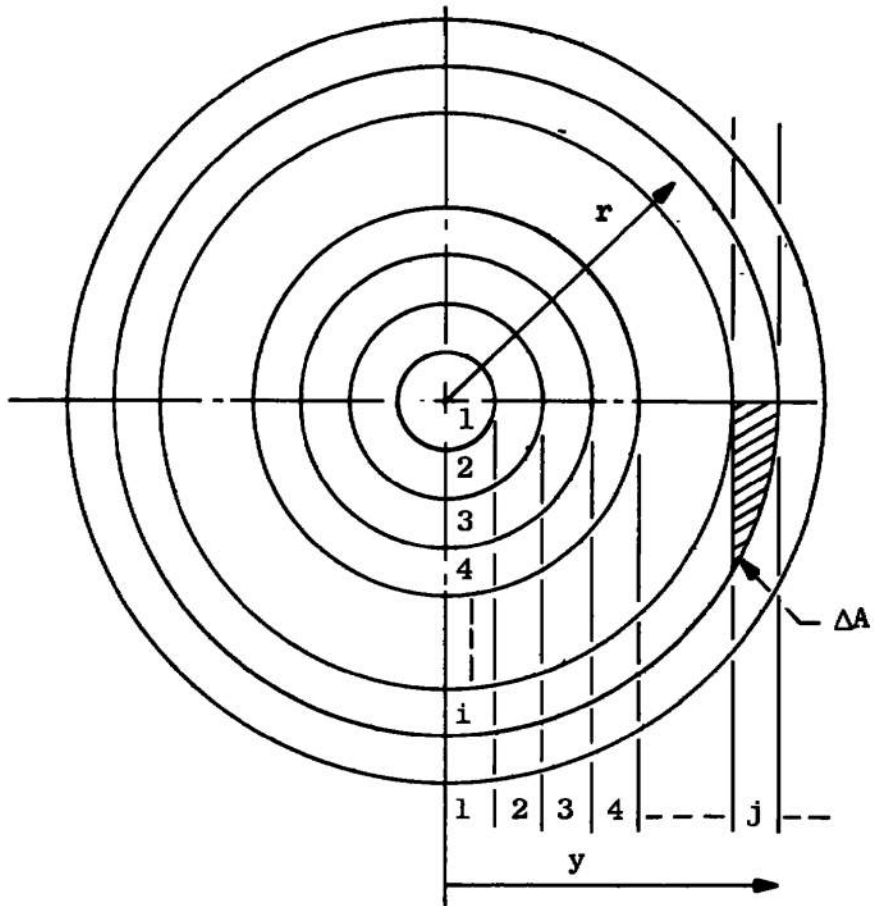

a. Multizone Plasma
Fig. 5 An Axisymmetric Plasma

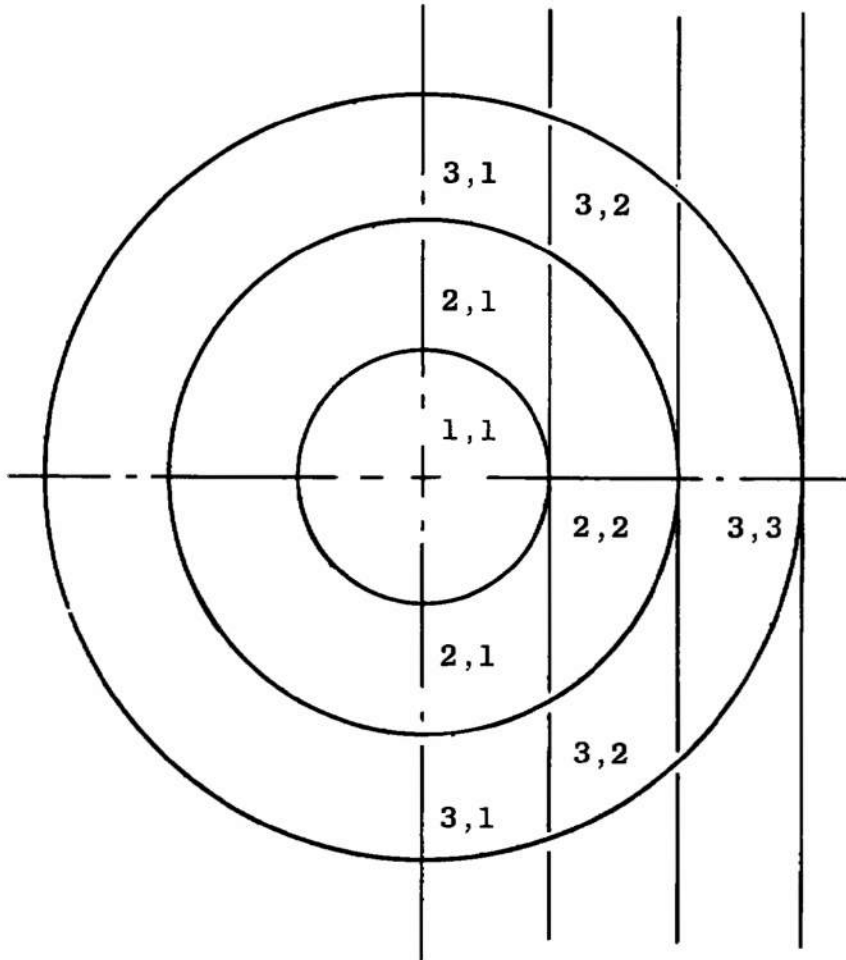

b. Three-Zone Plasma

Fig. 5 Concluded

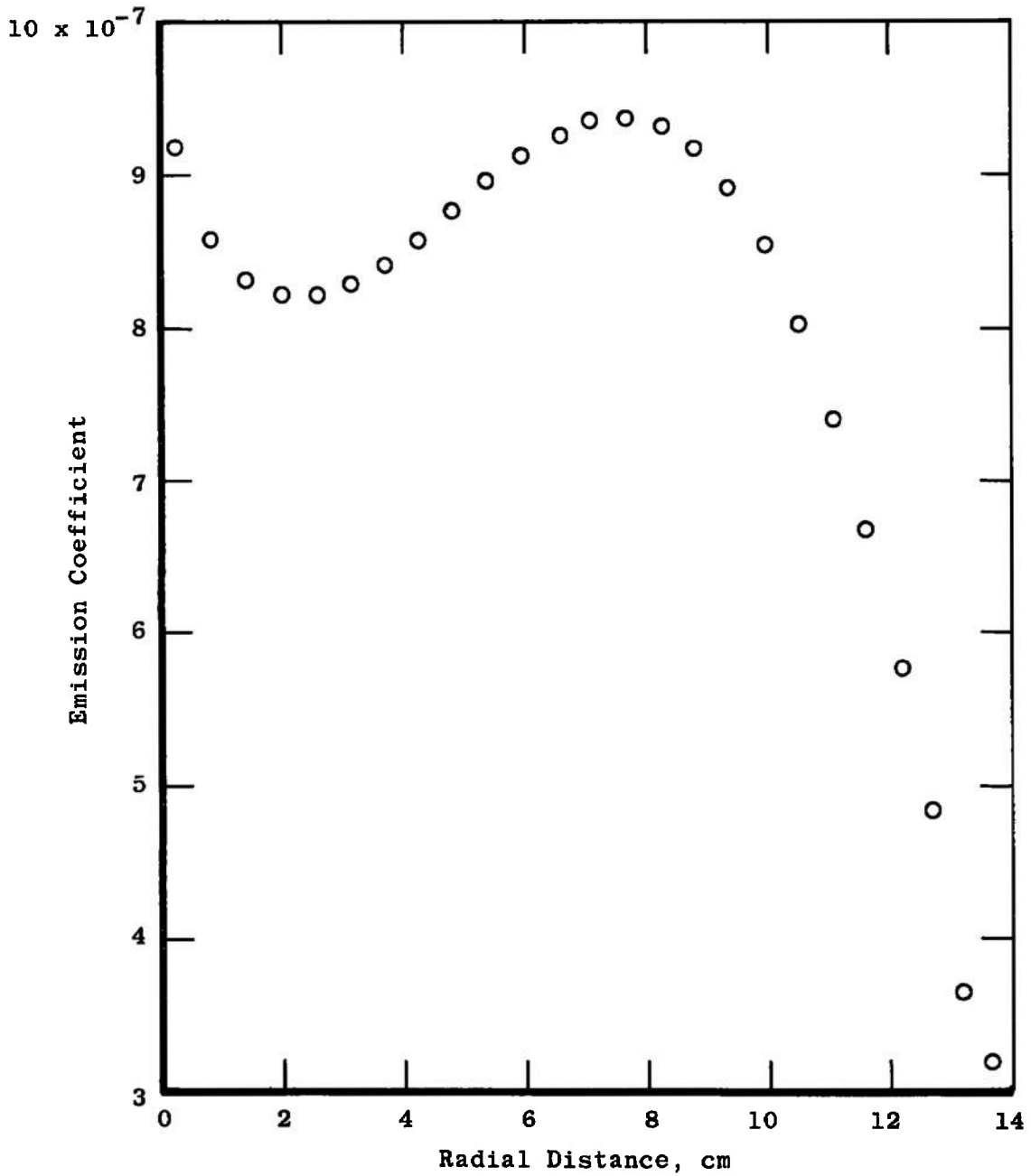

a. K I 4965-Å Line
Fig. 6 Typical Plots of Emission Coefficient versus Radius

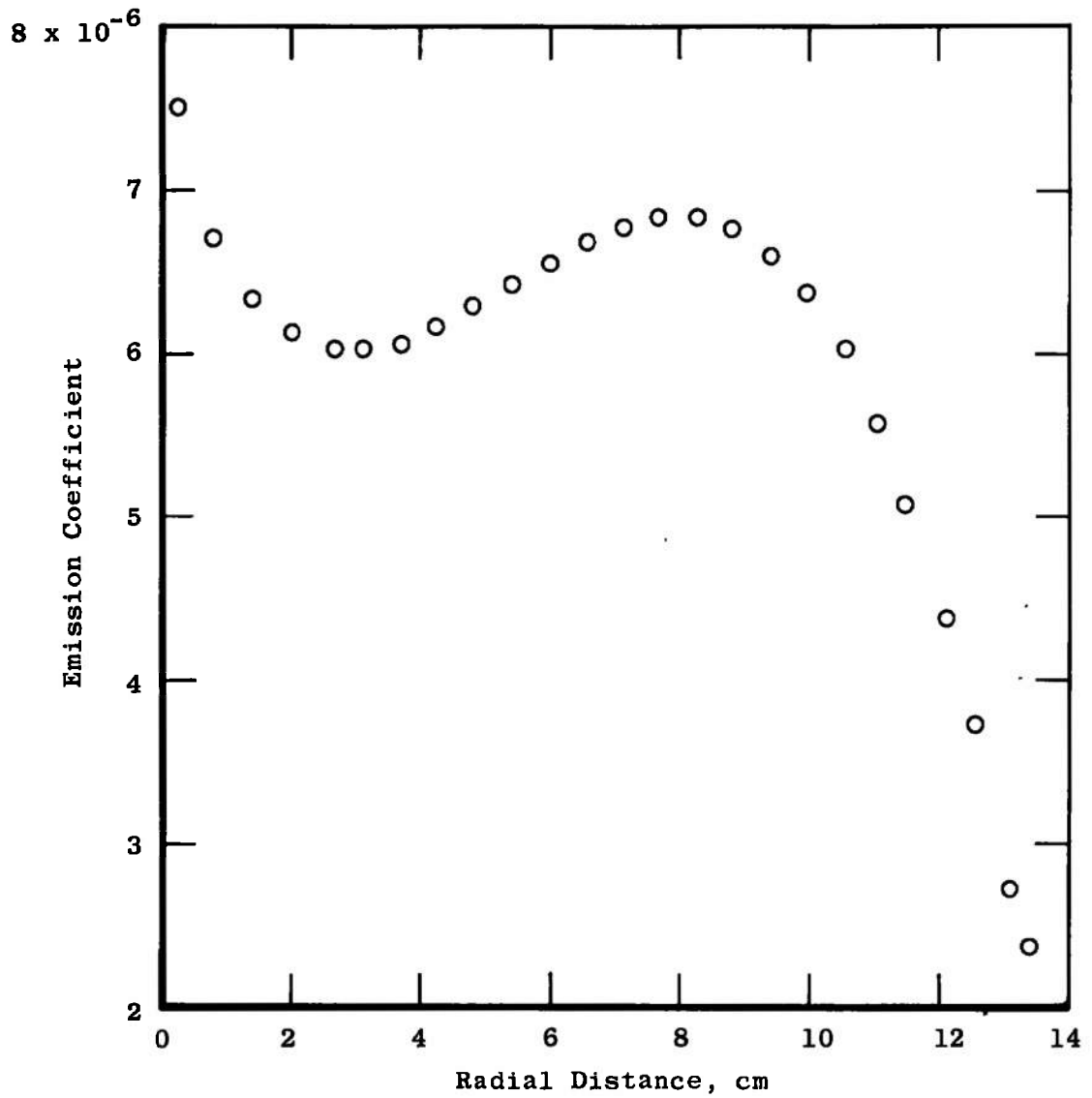

b. KI 5832-Å Line
Fig. 6 Concluded

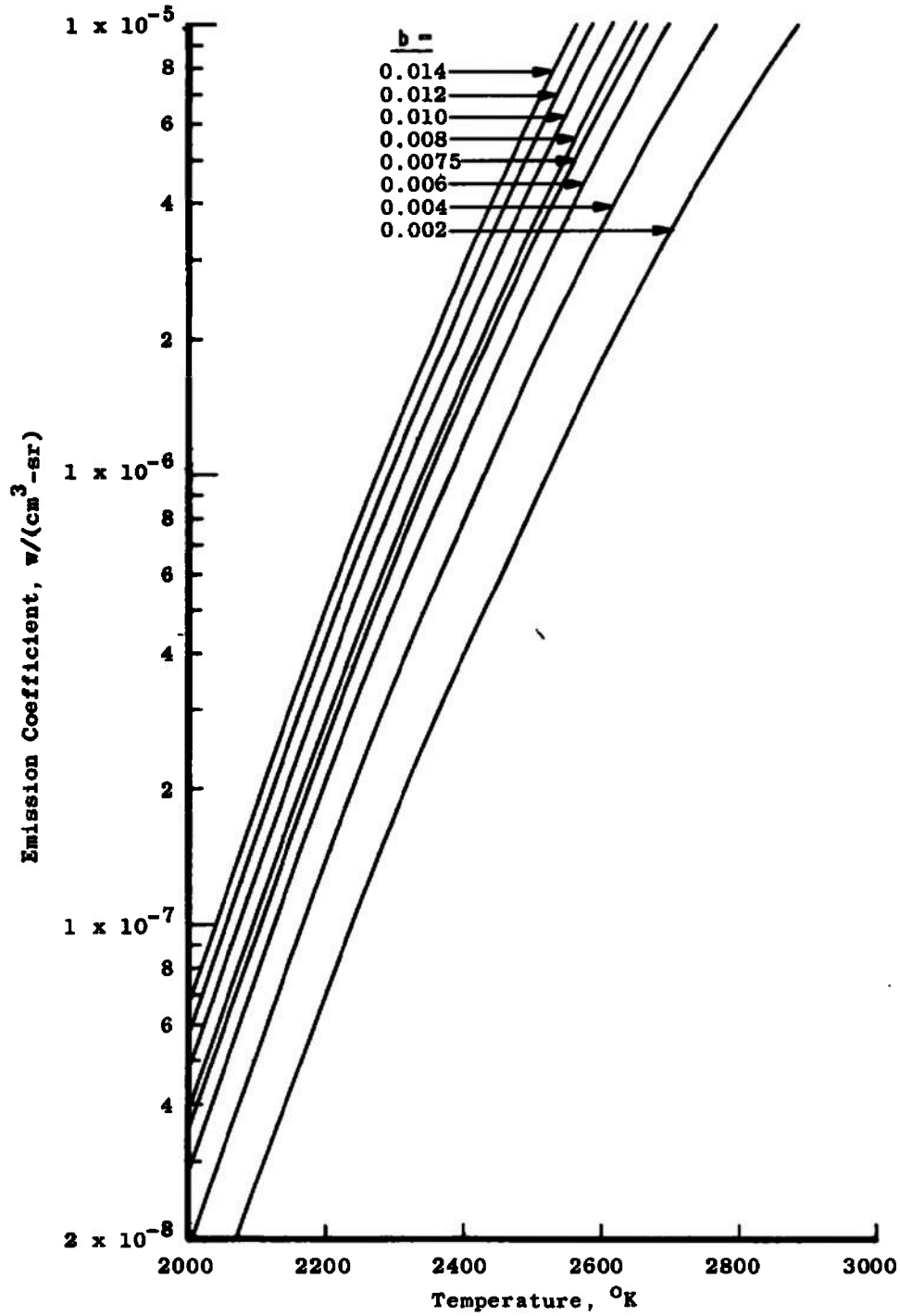

a. KI 4965-Å Line

Fig. 7 Emission Coefficient versus Temperature for Various Seed Concentrations

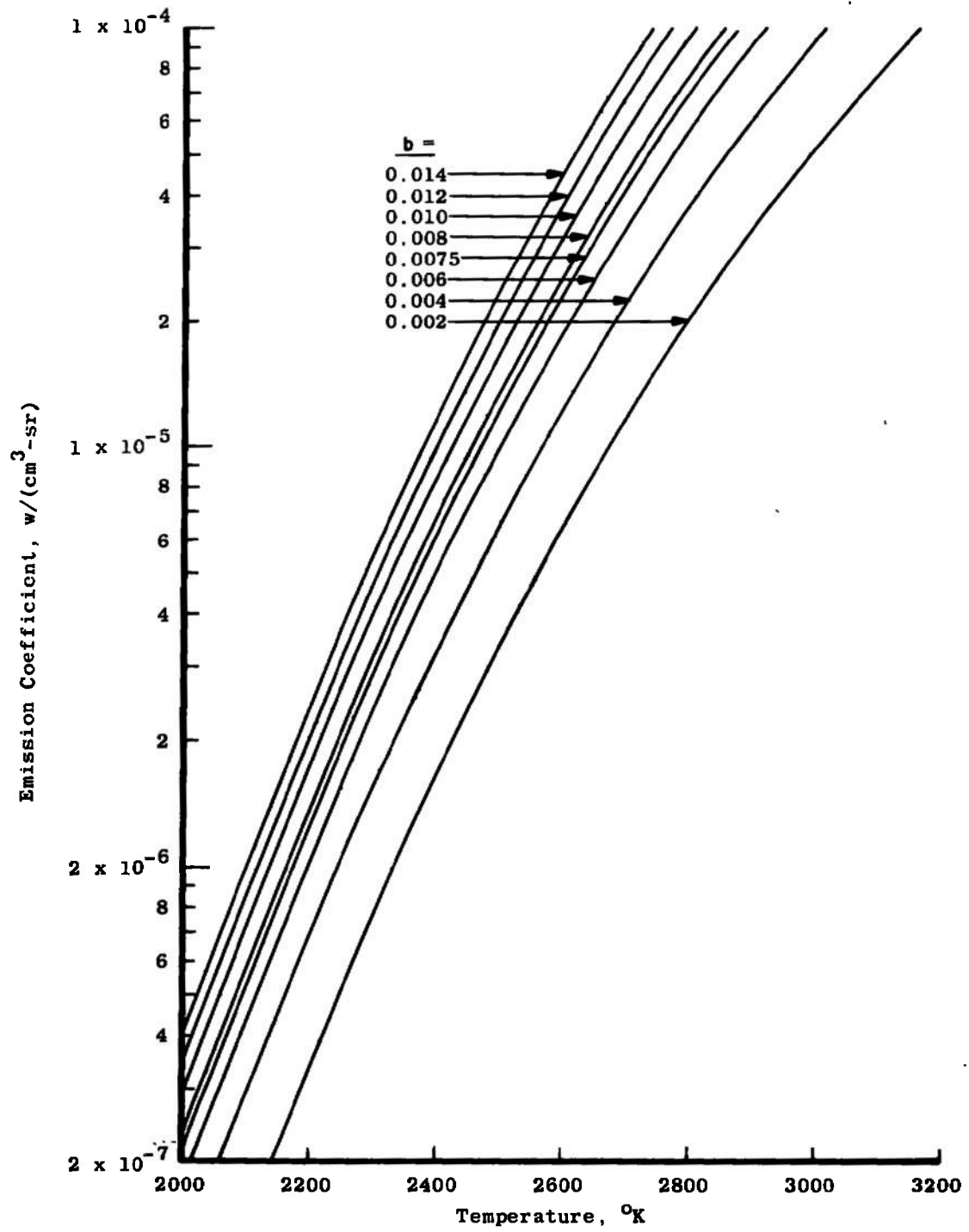

b. K I 5832-Å Line
 Fig. 7 Concluded

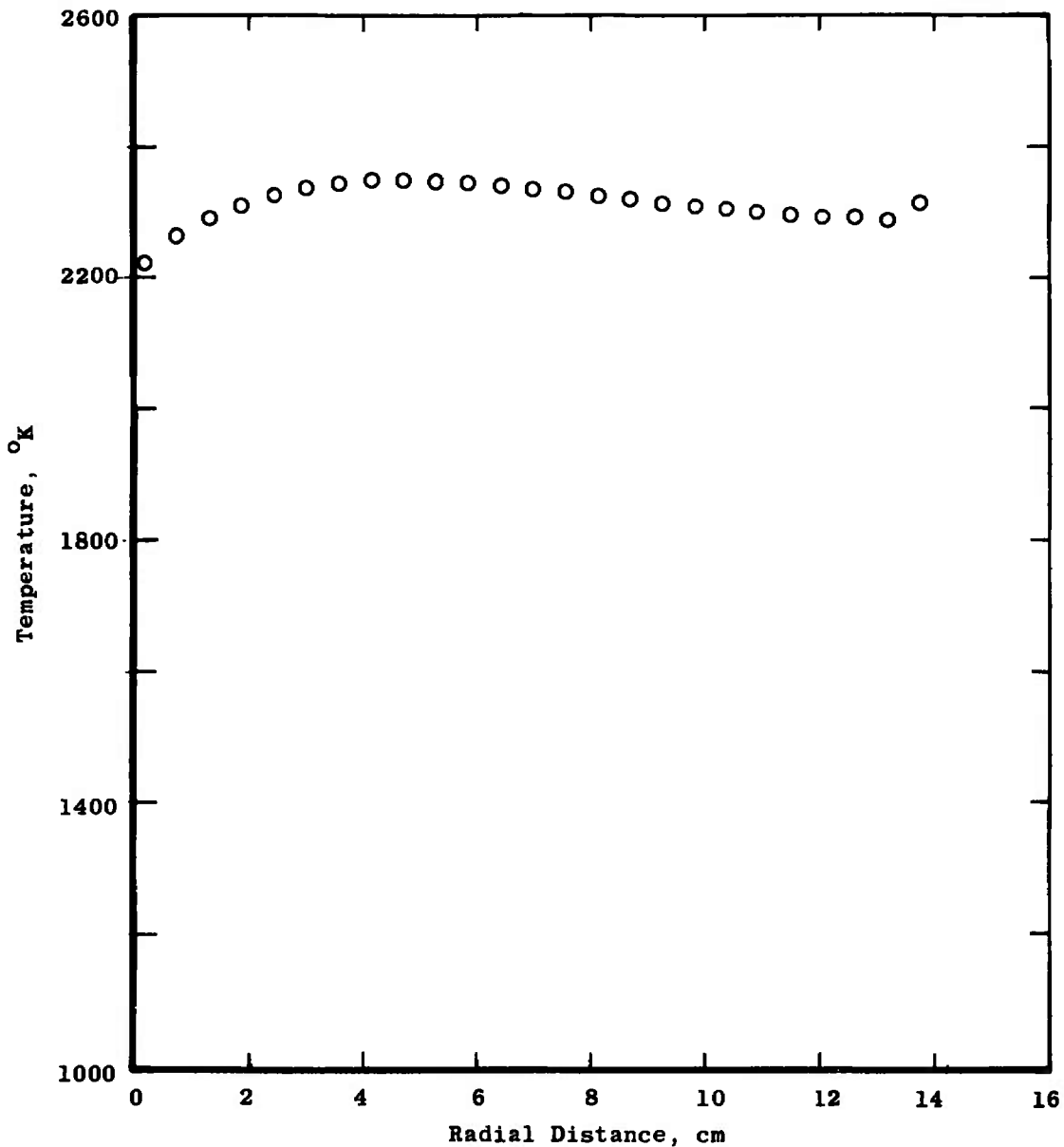

a. Pair 8, Left Hand
Fig. 8 Temperature versus Radius

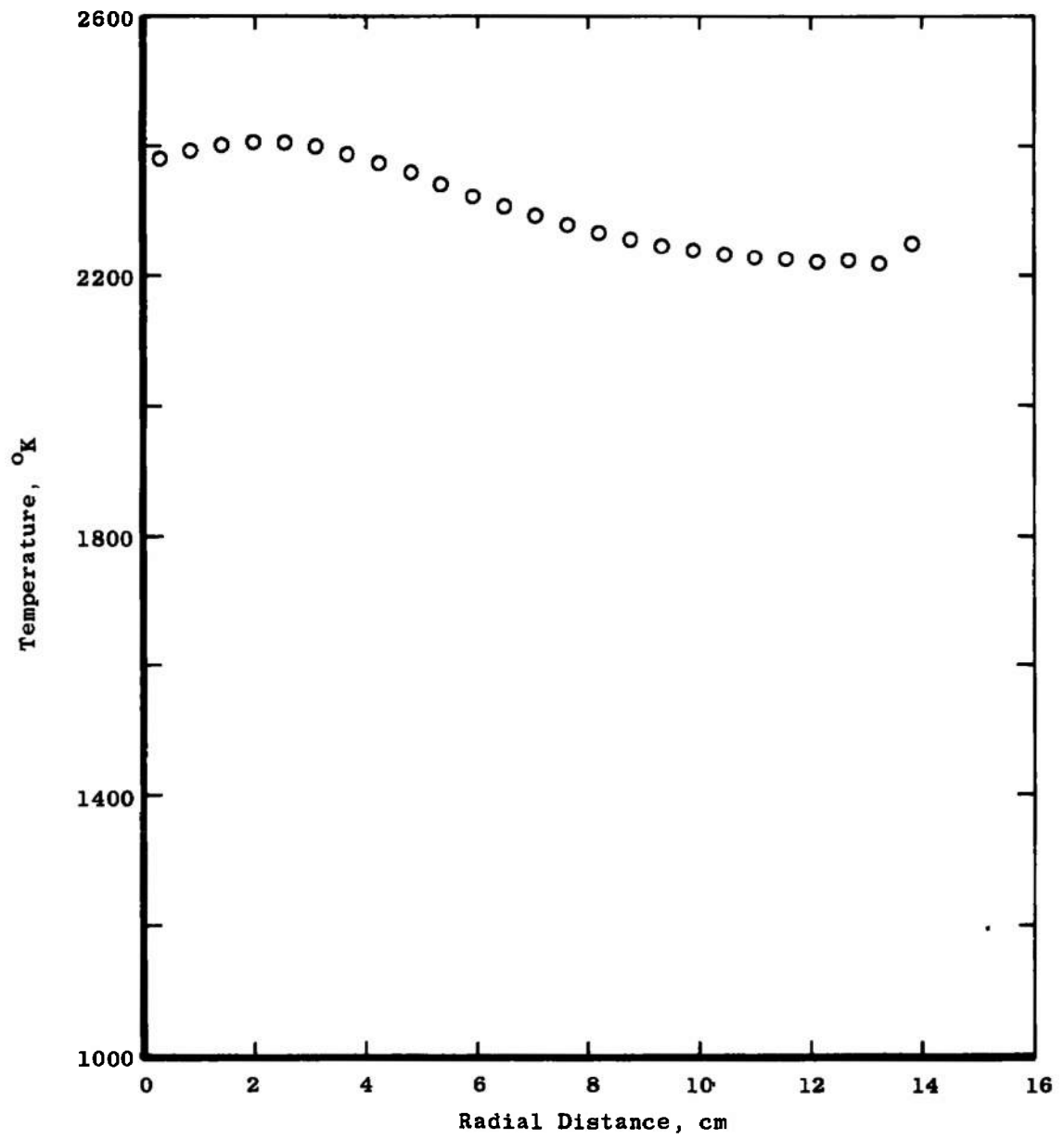

b. Pair 8, Right Hand
Fig. 8 Concluded

TABLE I
RESULTS OF TEMPERATURE MEASUREMENTS (°K) BY THE RATIO METHOD

Zone	Pair 8		Pair 17		Pair 23		Pair 26	
	Left Hand	Right Hand	Left Hand	Right Hand	Left Hand	Right Hand	Left Hand	Right Hand
1	2226	2384	2305	2458	2098	2404	2431	2744
2	2267	2398	2265	2428	2168	2429	2426	2732
3	2294	2406	2247	2408	2218	2443	2426	2715
4	2314	2410	2240	2393	2261	2451	2430	2692
5	2329	2409	2241	2382	2300	2452	2436	2664
6	2340	2403	2249	2376	2333	2447	2446	2632
7	2347	2392	2261	2373	2362	2436	2458	2598
8	2352	2378	2278	2374	2385	2421	2471	2566
9	2353	2362	2298	2377	2402	2404	2486	2535
10	2352	2344	2320	2382	2416	2386	2502	2508
11	2349	2327	2344	2388	2424	2367	2517	2485
12	2346	2311	2369	2394	2428	2350	2533	2466
13	2341	2296	2395	2400	2432	2335	2548	2451
14	2336	2282	2421	2404	2432	2322	2564	2439
15	2330	2270	2446	2408	2431	2311	2579	2431
16	2325	2259	2472	2410	2428	2302	2593	2426
17	2320	2250	2497	2411	2423	2296	2606	2424
18	2314	2243	2522	2410	2418	2292	2618	2425
19	2310	2236	2546	2406	2413	2290	2629	2429
20	2305	2231	2570	2400	2406	2291	2638	2436
21	2302	2228	2593	2387	2398	2298	2645	2450
22	2298	2225	2616	2376	2391	2304	2652	2463
23*								
24*								
25*								
Average	2320	2320	2386	2398	2362	2365	2529	2532

* The values of temperature for this zone are not included because of inaccuracy in measurement at the very low edge intensities and because of errors inherent in the data processing at the edge of the intensity distribution.

TABLE II
RESULTS OF TEMPERATURE MEASUREMENTS (°K) BY THE INTENSITY RATIO
APPLICATION OF THE RATIO METHOD

Zone	Pair 8		Pair 17		Pair 23		Pair 26	
	Left Hand	Right Hand	Left Hand	Right Hand	Left Hand	Right Hand	Left Hand	Right Hand
1	2321	2310	2382	2384	2364	2366	2523	2532
2	2324	2309	2382	2382	2372	2366	2525	2526
3	2327	2307	2384	2381	2380	2364	2528	2519
4	2330	2304	2388	2381	2388	2361	2531	2511
5	2331	2300	2393	2380	2395	2357	2536	2503
6	2332	2296	2400	2380	2403	2353	2542	2494
7	2332	2291	2409	2380	2408	2348	2548	2486
8	2331	2285	2420	2380	2412	2342	2555	2478
9	2330	2279	2431	2381	2416	2337	2562	2471
10	2329	2273	2444	2381	2418	2332	2570	2466
11	2326	2267	2459	2381	2419	2327	2578	2461
12	2324	2261	2473	2381	2418	2323	2586	2458
13	2321	2256	2489	2381	2417	2319	2594	2456
14	2318	2251	2505	2380	2415	2316	2602	2456
15	2315	2246	2522	2378	2412	2314	2610	2457
16	2312	2241	2539	2376	2408	2313	2617	2460
17	2309	2237	2557	2373	2403	2314	2624	2464
18	2306	2234	2574	2368	2398	2316	2630	2471
19	2304	2231	2592	2361	2392	2320	2635	2481
20	2302	2229	2610	2352	2386	2326	2639	2493
21	2302	2227	2628	2340	2378	2337	2640	2512
22	2302	2227	2646	2322	2368	2353	2637	2538
Average	2320	2266	2483	2373	2399	2337	2582	2486

TABLE III
CALCULATED VALUES OF TEMPERATURE (°K)

	<u>Pair 8</u>	<u>Pair 17</u>	<u>Pair 23</u>	<u>Pair 26</u>
Static Temperature, Air	2698	2734	2734	2698
Static Temperature, 90- percent N ₂ , 10-percent O ₂ , Corrected for Mass Flow	2876	2840	2840	2804
Static Temperature, 90- percent N ₂ , 10-percent O ₂ , Corrected for Mass Flow, γ Corrected for Mixture	3615	3572	3572	3540
Spectrometer, Line Ratio	2290	2428	2367	2534

DOCUMENT CONTROL DATA - R & D

(Security classification of title, body of abstract and indexing annotation must be entered when the overall report is classified)

1. ORIGINATING ACTIVITY (Corporate author) Arnold Engineering Development Center ARO, Inc., Operating Contractor Arnold Air Force Station, Tennessee		2a. REPORT SECURITY CLASSIFICATION UNCLASSIFIED	
		2b. GROUP N/A	
3. REPORT TITLE SPECTROSCOPIC DETERMINATION OF TEMPERATURE IN A POTASSIUM-SEEDED AIR PLASMA			
4. DESCRIPTIVE NOTES (Type of report and inclusive dates) March and April, 1968 - Final Report			
5. AUTHOR(S) (First name, middle initial, last name) J. W. Gearhart, ARO, Inc.			
6. REPORT DATE February 1970		7a. TOTAL NO. OF PAGES 42	7b. NO. OF REFS 4
8a. CONTRACT OR GRANT NO F40600-69-C-0001		9a. ORIGINATOR'S REPORT NUMBER(S) AEDC-TR-69-216	
b. PROJECT NO 4344		9b. OTHER REPORT NO(S) (Any other numbers that may be assigned this report) N/A	
c. Program Element 65701F			
d.			
10. DISTRIBUTION STATEMENT This document has been approved for public release and sale; its distribution is unlimited.			
11. SUPPLEMENTARY NOTES Available in DDC		12. SPONSORING MILITARY ACTIVITY Arnold Engineering Development Center, Air Force Systems Command Arnold Air Force Station, Tenn.37389	
13. ABSTRACT Spectroscopic measurements of radial electron excitation temperature distributions were made at the exit of a seeded, 2-mw arc heater. A nitrogen-oxygen mixture (about 3:1 in mass flow) was seeded with potassium carbonate. Potassium I lines were used in the determination of temperature by the ratio method. A modification to the ratio method was devised so that two different lines, observed under different conditions, could be correctly employed in the ratio method. The experimentally determined temperature profiles were nearly uniform across the plasma stream but varied in magnitude from run to run. Relative potassium I atom concentrations were nonuniform, but nearly radially symmetric, and exhibited an off-axis peak.			

14.

KEY WORDS

LINK A

LINK B

LINK C

ROLE

WT

ROLE

WT

ROLE

WT

spectroscopic analysis
electron temperature
temperature distribution
arc heaters
line spectra