

UNCLASSIFIED

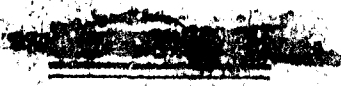

AD 703362

**CORPS OF ENGINEERS
U. S. ARMY**

**COMPREHENSIVE REPORT
INVESTIGATION OF MILITARY CONSTRUCTION
IN ARCTIC AND SUBARCTIC REGIONS
1945-1948**

**APPENDIX III
DESIGN AND CONSTRUCTION STUDIES
AT FAIRBANKS RESEARCH AREA**

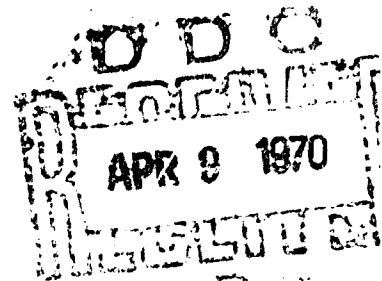

**PREPARED BY
ST. PAUL DISTRICT
CORPS OF ENGINEERS
FOR
OFFICE OF THE CHIEF OF ENGINEERS
AIRFIELDS BRANCH
ENGINEERING DIVISION
MILITARY CONSTRUCTION**

JUNE 1950

Best Available Copy

**This document has been approved
for public release and its
distribution is unlimited**

UNCLASSIFIED

102

[REDACTED]

CORPS OF ENGINEERS
U. S. ARMY

COMPREHENSIVE REPORT
INVESTIGATION OF MILITARY CONSTRUCTION
IN ARCTIC AND SUBARCTIC REGIONS
1945-1948

APPENDIX III
DESIGN AND CONSTRUCTION STUDIES
AT FAIRBANKS RESEARCH AREA



PREPARED BY
ST. PAUL DISTRICT
CORPS OF ENGINEERS
FOR
OFFICE OF THE CHIEF OF ENGINEERS
AIRFIELDS BRANCH
ENGINEERING DIVISION
MILITARY CONSTRUCTION

JUNE 1950

[REDACTED]

This document has been approved
for public release and sale; its
distribution is unlimited

TABLE OF CONTENTS

Paragraph		Page
I Introduction		
1	PURPOSE	1
2	GENERAL CONDITIONS	1
3	CONSTRUCTION HISTORY	3
II Area No. 1 -- Ground and Pavement Surface Studies		
4	DESCRIPTION	3
5	INSTALLATION OF OBSERVATIONAL FACILITIES	4
6	GROUND TEMPERATURE OBSERVATIONS	6
7	GROUNDWATER OBSERVATIONS	6
8	VERTICAL MOVEMENT OBSERVATIONS	6
9	DETERMINATION OF NATURAL MOISTURE CONTENT AND DRY DENSITY OF SOILS	6
10	APPLICATION OF PROBING METHODS COMPARED TO GROUND TEMPERATURE DATA	6
III Area No. 2 -- Runway Foundation Studies		
11	DESCRIPTION	7
12	INSTALLATION OF OBSERVATIONAL FACILITIES	7
13	GROUND TEMPERATURE OBSERVATIONS	12
14	GROUNDWATER OBSERVATIONS	12
15	NATURAL MOISTURE CONTENT AND DRY DENSITY OF BACKFILL AND SUBGRADE	12
16	VERTICAL MOVEMENT OF GROUND AND TEST SECTION SURFACES	13
IV Area No. 3 -- Building and Piling Studies		
17	DESCRIPTION	13
18	INSTALLATION OF OBSERVATIONAL FACILITIES	13
19	GROUND TEMPERATURE OBSERVATIONS	17
20	GROUNDWATER OBSERVATIONS	17
21	NATURAL MOISTURE OF SUBGRADE	18
22	VERTICAL MOVEMENT OF GROUND AND TEST STRUCTURES	18
23	NAVY MONOTUBE TEST PILING	18

TABLE OF CONTENTS (CONT'D)

List of Tables

Table No.		Page
III-1	ANALYSES OF TYPICAL SOIL SAMPLES -- FAIRBANKS RESEARCH AREA -- AREA NO. 1 -- SECTION B	2
III-2	FAIRBANKS RESEARCH AREA NO. 2 -- RUNWAY TEST SECTIONS	8
III-3	FAIRBANKS RESEARCH AREA NO. 3 -- TEST BUILDINGS 1 to 11 . . .	14

List of Figures

Figure No.		
III-1	General view	1
III-2	Area 1	4
III-3	Area 1, Section C	5
III-4	Area 1, Section B	5
III-5	Area 1, Section A	5
III-6	Area 2, General view.	9
III-7	Area 2, Thick gravel fills.	9
III-8	Area 2, Stripping surface.	10
III-9	Area 2, Drainage	10
III-10	Area 2, Insulation layers	10
III-11	Area 2, Insulation layers	10
III-12	Area 2, Cell concrete insulation	11
III-13	Area 2, Base course construction	11
III-14	Area 2, Foamglas insulation.	11
III-15	Area 2, Cell concrete insulation	11
III-16	Area 3, General view.	13
III-17	Area 3, Bldg. No. 1 floor	15
III-18	Area 3, Bldg. No. 5 floor	15
III-19	Area 3, Bldg. No. 6 floor	15
III-20	Area 3, Bldg. No. 7 floor	15
III-21	Area 3, Bldg. No. 8 foundation.	16
III-22	Area 3, Bldg. floor insulation	16
III-23	Area 3, Bldgs. 9, 10 and 11	16
III-24	Area 3, Bldg. No. 10 floor and foundation	16
III-25	Area 3, Steam thawing.	17
III-26	Area 3, Placing piling	17
III-27	Area 3, Vertical movement observation point.	18
III-28	Area 3, Swellometer	18
III-29	Area 3, Monotube test pile	19
III-30	Area 3, Pile loading platform	19

TABLE OF CONTENTS (CONT'D)

List of Plates

Plate No.	<u>Title</u>
III-1	General Plan
III-2	Air Temperatures
III-3	Weeks Field, Meteorological Data, Precipitation and Snow Cover
III-4	Meteorological Studies, U.S.W.B. Weather Station, Weeks Field, Degree Days Above and Below 32° F
III-5	Area No. 1, Ground and Pavement Surface Studies
III-6	Area No. 2, Runway Foundation Studies
III-7	Area No. 3, Plan
III-8	Grain Size Accumulation Curves, Typical Soil Samples, Areas 1, 2 and 3.
III-9	Area No. 1, Hole No. A, Ground Isotherms and Surface Elevations -- 1946
III-10	Area No. 1, Hole No. A, Ground Isotherms and Surface Elevations -- 1946-47
III-11	Area No. 1, Hole No. A, Ground Isotherms and Surface Elevations -- 1947-48
III-12	Area No. 1, Hole No. B, Ground Isotherms and Surface Elevations -- 1946
III-13	Area No. 1, Hole No. B, Ground Isotherms and Surface Elevations -- 1946-47
III-14	Area No. 1, Hole No. B, Ground Isotherms and Surface Elevations -- 1947-48
III-15	Area No. 1, Hole No. C, Ground Isotherms and Surface Elevations -- 1946
III-16	Area No. 1, Hole No. C, Ground Isotherms and Surface Elevations -- 1946-47
III-17	Area No. 1, Hole No. C, Ground Isotherms and Surface Elevations -- 1947-48
III-18	Area No. 1, Hole No. DN, Ground Isotherms and Surface Elevations -- 1947-48
III-19	Area No. 1, Hole No. DB, Ground Isotherms and Surface Elevations -- 1948
III-20	Area No. 1, Hole No. DW, Ground Isotherms and Surface Elevations -- 1948
III-21	Area No. 1, Section B, Seasonal Field Moisture Comparison
III-22	Area No. 1, Depth of Thaw Obtained by Probing, Ground Temperatures -- 1946-47
III-23	Area No. 1, Depth of Thaw Obtained by Probing, Ground Temperatures -- 1947-48
III-24	Areas 2 and 3, Backfill Material, Moisture Density Curves
III-25	Typical Grain Size Accumulation Curves of Backfill Material
III-26	Area No. 2, Runway Foundation Studies, Frozen and Unfrozen Zones, 1 Nov. 46
III-27	Area No. 2, Runway Foundation Studies, Frozen and Unfrozen Zones, 1 Feb. 47
III-28	Area No. 2, Runway Foundation Studies, Frozen and Unfrozen Zones, 1 April 47
III-29	Area No. 2, Runway Foundation Studies, Frozen and Unfrozen Zones, 1 May 47
III-30	Area No. 2, Runway Foundation Studies, Frozen and Unfrozen Zones, 1 Oct. 47
III-31	Area No. 2, Runway Foundation Studies, Frozen and Unfrozen Zones, 31 Oct. 47
III-32	Area No. 2, Runway Foundation Studies, Frozen and Unfrozen Zones, 1 Feb. 48
III-33	Area No. 2, Runway Foundation Studies, Frozen and Unfrozen Zones, 1 April 48
III-34	Area No. 2, Runway Foundation Studies, Frozen and Unfrozen Zones, 1 May 48
III-35	Area No. 2, Runway Foundation Studies, Frozen and Unfrozen Zones, 1 Oct. 48
III-36	Area No. 2, Runway Foundation Studies, Frozen and Unfrozen Zones, 31 Oct. 48
III-37	Area No. 3, Building Foundations
III-38	Area No. 3, Design of Swellometer
III-39	Area No. 3, Ground Temperature Observations, 1 Nov. 46
III-40	Area No. 3, Ground Temperature Observations, 1 Feb. 47
III-41	Area No. 3, Ground Temperature Observations, 1 April 47
III-42	Area No. 3, Ground Temperature Observations, 5 June 47
III-43	Area No. 3, Ground Temperature Observations, 5 Sept. 47

TABLE OF CONTENTS (CONT'D)

List of Plates (Cont'd)

<u>Plate No.</u>	<u>Title</u>
III-44	Area No. 3, Ground Temperature Observations, 30 Oct. 47
III-45	Area No. 3, Ground Temperature Observations, 1 Feb. 48
III-46	Area No. 3, Ground Temperature Observations, 1 April 48
III-47	Area No. 3, Ground Temperature Observations, 5 June 48
III-48	Area No. 3, Ground Temperature Observations, 5 Sept. 48
III-49	Area No. 3, Ground Temperature Observations, 30 Oct. 48
III-50	Area No. 3, Building No. 1, Field Moistures
III-51	Area No. 3, Monotube Test Piles, Vertical Movement and Ground Temperature Chart

COMPREHENSIVE REPORT

INVESTIGATION OF AIRFIELD CONSTRUCTION IN ARCTIC AND SUBARCTIC REGIONS

APPENDIX III

DESIGN AND CONSTRUCTION STUDIES AT FAIRBANKS RESEARCH AREA

I Introduction

1. **PURPOSE.** The Fairbanks Research Area was constructed for the purpose of providing an opportunity to observe various types of structures erected on permafrost under conditions that would be known and recorded from the beginning to the conclusion of operations.

2. **GENERAL CONDITIONS.** The Research Area is located about 2-1/2 miles northeast of Fairbanks, Alaska. See Plate III-1 and Figure III-1. The terrain on which it is built is characterized by a comparatively smooth gentle slope which generally provides good surface drainage. Geologically, the Research Area is located on the lower colluvial slopes between the valley fill and the upper colluvial slopes of the rock upland known as Birch Hill. The mean annual temperature at Fairbanks is about 26° F with extremes of +88° F and -58° F. The total annual precipitation is about 12 in., including the annual snowfall of about 4 ft. Mean daily air temperatures, meteorological data and degree-days above and below 32° F during 1947-48 are shown on Plates III-2, III-3, and III-4, respectively. The natural soil underlying the Research Area to a depth of 50 ft is



Figure III-1. General view. Area 1 at top center. Area 2 at left. Area 3 at lower center. July 1948.

principally silt with some fine sand and occasional layers of peat. Analyses of typical soil samples are shown in Table III-1. Under natural conditions, permafrost is encountered at depths of 3 to 6 ft below the surface. The site of the investigation has been divided

TABLE III-1
ANALYSES OF TYPICAL SOIL SAMPLES
FAIRBANKS RESEARCH AREA
AREA NO. 1 -- SECTION B

Sample Number	699	671	677
Depth below ground surface, ft	2.0	6.0	30.0
<u>Physical Constants</u>			
1. All fractions of sample			
Moisture -- field condition, %	74	28	35
Natural density, lb per cu ft	56	91	81
Specific gravity	2.72	2.76	2.70
Natural porosity, %	67	47	52
Natural voids ratio	2.03	.89	1.08
2. Fraction passing no. 40 sieve			
Plasticity index	Non-plastic	Non-plastic	Non-plastic
<u>Mechanical Analysis</u>			
Percent of total sample			
Grain size in in. or US standard sieve no.			
Gravel:	no. 10 to 3 in.	0	0
Coarse,	1 to 3 in.	-	-
Medium,	no. 4 to 1 in.	-	-
Fine,	no. 10 to no. 4	-	-
Sand:	no. 200 to no. 10	4	4
Coarse,	no. 40 to no. 10	0	0
Fine,	no. 200 to no. 40	4	4
Silt or clay:	Less than no. 200	96	96
Effective size in mm	.0067	.023	.0058
Uniformity coefficient	3.4	1.9	5.0
Class (textural)	Silt	Silt	Silt
USED soil group	ML	ML	ML
<u>Miscellaneous Characteristics</u>			
Color	Brown	Gray	Gray
Frozen or unfrozen	Frozen	Frozen	Frozen
Ice lenses present	Yes	Yes	Yes

into three areas as shown on Plate III-1 and in detail for each area on Plates III-5, III-6, and III-7. The general plan is as follows:

- a. Area No. 1 -- ground and pavement surface studies. In this area, the effect of the climatic factors such as air temperature, solar radiation, wind velocity, humidity, cloudiness, and precipitation, on ground temperature, especially where permafrost is present, will be determined under various ground and pavement surface conditions. See Plate III-5 and Figures III-2 to III-5, inclusive (pages 4 and 5).
- b. Area No. 2 -- runway foundation studies. The effect of the construction of runway sections with various pavement types, insulators and base courses on ground temperatures will be determined. See Plate III-6 for the various combinations of fill, insulation and surfaces constructed and under observation. See Figures III-6 through III-15 (pages 9, 10 and 11).
- c. Area No. 3 -- building foundation studies. Buildings have been constructed with various ground exposures and insulators to determine the effect of these types of foundation construction on ground temperatures, especially on the permafrost. Pile foundations will be studied to a limited extent from several piles installed at various depths of embedment in the permafrost to determine whether the freezing and heaving of the active layer will displace the piles. See Plate III-7 and Figures III-16-III-30 (pages 13, 15, 16-19).

3. CONSTRUCTION HISTORY. Construction at the Fairbanks Research Area was started in April 1946 by the Alaskan Department with inspection and supervision by Permafrost Field Office personnel of the St. Paul District Office, CE. Core and churn drilling operations were started in February 1946 and all scheduled borings were completed in June 1946. Continuous samples were taken from all core borings with nearly 100 percent recovery in the frozen silt. Installation of all special equipment, such as ground temperature observation equipment, was made by employees of the Permafrost Field Office. Clearing and stripping operations were started in March and April 1946, respectively. General construction operations were started in April 1946 and completed in the fall of 1947 following changes in plans involving the construction of additional structures. Facilities are provided in each test area for the observation of ground temperatures, groundwater levels, vertical movement of ground surface, pavement surface, or structure, probing to ground frost level, and obtaining soil density samples. Observations of ground temperatures are presently being made at weekly intervals. Groundwater levels are also observed at 2-week intervals during the open season. Vertical movements are observed at one-month intervals. Probing is made at 2-month intervals to check the ground frost levels. Test pits are excavated and soil density tests are made as required at critical places in the foundations. Climatic factors are being observed daily in the area.

II Area No. 1 -- Ground and Pavement Surface Studies

4. DESCRIPTION. Test sections in this area for determining the effect of climatic factors such as air temperature, solar radiation, wind velocity, humidity, cloudiness, and precipitation on ground temperatures include the following four sections, as shown on Plate III-5 and Figures III-2 through III-5.

- a. Section "A" consists of an undisturbed area, 200 ft by 200 ft, with natural

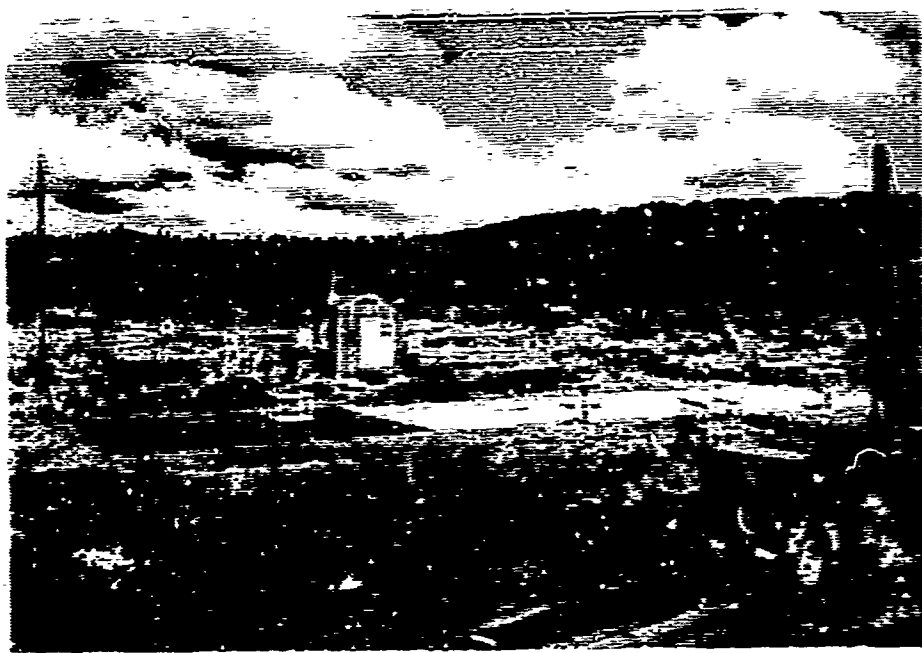

Figure III-2. Area 1, Sections A, B, C and D from left background to foreground. July 1948

cover of vegetation including moss, brush, and spruce trees. See Figure III-5.

b. Section "B" consists of an area, 200 ft by 200 ft, in natural surface condition but with trees and brush removed. See Figure III-4.

c. Section "C" consists of an area, 200 ft by 200 ft, with vegetation removed and with surface soil stripped off to a depth of about 16 in. See Figure III-3.

d. Section "D" consists of an area, 30 ft by 90 ft, stripped to a depth of 12 in. and backfilled with sand to the original ground line and paved with 6 in. of concrete. One-third of the surface area of the pavement is colored black, one-third is colored white, and the remaining third is an uncolored concrete surface. A temperature equipment test area has also been established in Area No. 1 for the comparison of various types of equipment and installations for measuring ground temperatures. The soil in Area No. 1, as is the case throughout the Research Area, is composed of silt and peat. See Plate III-8 and Figure III-2.

5. INSTALLATION OF OBSERVATIONAL FACILITIES. Facilities are provided in Area No. 1 for the observation of ground temperatures, groundwater levels, vertical movement of ground surface, depth to permafrost by probing, and the taking of soil samples for natural moisture and density determinations. The location of each of these facilities is shown on Plate III-5. Ground temperatures are observed at intervals to a depth of 30 ft by means of thermocouples placed in oil-filled 3/4-in. steel pipe or directly in the ground. Continuous temperature records are made in each of Sections DB, DN, and DW with Leeds and Northrup "Micromax" recording equipment using resistance thermometers placed at depths varying from the pavement surface to 6 ft below the pavement surface. Vertical movement observation points in unsurfaced areas consist of 3/4-in. steel rod, 7-3/4 in. long, anchored by welding to a slotted 1/2-in. steel plate one foot square. In concrete paved areas, they consist of 1/2- by 2-in. bolts grouted into the pavement flush with the surface. In asphalt surfacing and gravel surfacing in Area No. 2, they consist of 25d and 80d nails, respectively, driven so that the head just protrudes above the surface. Groundwater elevations are observed by means of a graduated rod in groundwater wells consisting of 2-in. steel pipe casings fitted with 80 mesh well points. Vertical movement points and groundwater wells are similar throughout the Research Area. Probing is accomplished by means of a 1/4-in. or 1/2-in. steel rod and, if results appear indefinite, they are supplemented by borings with a 1-1/2-in. soil auger. During October 1947, a temperature equipment test area was established in Area No. 1 to test various types of installations for the measurement of ground temperatures. The equipment tested included



Figure III-3. Area 1, Section C
Close-up of stripped surface.
September 1946



Figure III-4. Area 1, Section B
Close-up of cleared surface.
September 1946



Figure III-5. Area 1, Section A. Close-up of undisturbed natural
cover. October 1946

thermocouples, resistance thermometers, and mercury thermometers. Nine installations were made; of which six included thermocouples, two included resistance thermometers, and one included mercury thermometers. The thermocouples were installed in direct contact with the ground, in steel pipes filled with oil, and in steel pipes filled with sand.

6. **GROUND TEMPERATURE OBSERVATIONS.** The period of record for observations of ground temperatures in Sections A, B and C, which represent natural vegetative cover, a cleared area, and a stripped area, respectively, extends from July 1946 to 31 October 1948. Observations were made daily from the beginning date until March 1947 and weekly from that date. The change in schedule was made when it became apparent that the rate of change of ground temperatures was not great enough to make daily readings necessary. For Section D in which the effect of different surface colors in concrete pavement on underlying ground temperatures is to be observed, thermocouple installations were not made until late in the fall of 1947. Ground temperatures in hole D, located beside Section D, have been periodically observed from 11 November 1946. Continuous records of ground temperatures have been made in each of the 3 colored sections in Section D since about 20 June 1948. These records are of short duration but voluminous and have not been completely analyzed. Plates III-9 to III-17, inclusive, show ground isotherms at the centers of Sections A, B, and C, for the period July 1946 to 31 October 1948. Plates III-18 to III-20, inclusive, show similar information for Sections DN, DB, and DW for the period 1 October 1947 to 31 October 1948.

7. **GROUNDWATER OBSERVATIONS.** Groundwater levels are observed at 6 points in Area No. 1. Observations are possible only during the period from May to October, inclusive, because the wells are frozen during the remainder of the year. Present data cover the periods from 8 June to 25 September 1946, from 27 May to 29 October 1947, and from 26 May to 27 October 1948, at weekly intervals.

8. **VERTICAL MOVEMENT OBSERVATIONS.** Vertical movement was observed in Area No. 1 at 9 points, to determine the extent of heave and settlement of the ground surface and to compare this movement as it occurs under varying conditions of vegetative surface cover. Three points are located in each of Sections A, B and C. Twenty observations were taken at each point at intervals during the period from 22 November 1946 to 2 October 1948. Data are plotted on Plates III-10, 11, 13, 14 and 16 to 20, inclusive.

9. **DETERMINATION OF NATURAL MOISTURE CONTENT AND DRY DENSITY OF SOILS.** In order to obtain undisturbed soil samples for the determination of natural moisture content and dry field density, test pits were dug in Sections A, B, and C of Area No. 1 on 23 and 24 September 1947 and 4 September 1948. Results of natural moisture tests on samples obtained from the initial core borings and a typical test pit in Section B are shown on Plate III-21.

10. **APPLICATION OF PROBING METHODS COMPARED TO GROUND TEMPERATURE DATA.** Probing for the determination of the depth to the permafrost table and the frost table are taken periodically at 9 frost observation points in Area No. 1, 10 frost observation points in Area No. 2, and 3 frost observation points in Area No. 3, as shown on Plates III-5, III-6, and III-7, respectively. Observations have been taken at intervals of two months since 17 October 1946. All probe points in Areas Nos. 1 and 3, and 4 of the 10 points in Area No. 2 are located adjacent to ground temperature holes, so that a direct comparison of data obtained by the two methods can be made. Results were found to be quite similar for all points. Therefore, points A, B, and C in Area No. 1 have been selected as typical for purposes of this discussion. These points are located at the centers

of Sections A, B, and C. Plates III-22 and III-23 show the 0°C isotherm as plotted from ground temperature observations and the locations of permafrost and seasonal frost levels as plotted from probing data for points A, B, and C during the period of record. It is noted that differences up to two feet between the two methods occurred during 1948. In this connection it has been observed that, after seasonal frost begins to penetrate from the surface in the fall, ground temperatures tend to appear somewhat erratic, probably due to the rapidly changing temperature gradients. By the thermocouple installations, positive location of the 0°C isotherm can be determined only when it coincides with the depth to one of the thermocouples. The plotting of isotherms between these depths is a matter of interpolation which tends to reduce the accuracy of plotting, especially when temperature gradients are changing rapidly. For this reason, it is not considered proper to regard all variation in results between the two methods as being due to inaccuracies in probing. The accuracy of the ground temperature method would be greatly increased by spacing the thermocouples closer together. For future installations, it is considered advisable to place thermocouples at one-foot intervals to the probable depth of thaw. The reliability of probing data is affected by the nature of the soil involved. In fine-grained soils which offer little resistance to the probing rod when thawed and wet, the point of contact with a frozen layer is quite definite. Sand has a tendency to bind the rod, which makes it harder to drive, so that the point of contact with frozen soil is not as easily detected. It has been noted from past experience, however, that the resistance of the rod to twisting affords a criterion. A torque is applied to the rod by means of a pipe wrench when it is suspected that the point has entered frozen soil. If the point is embedded in frozen ground, it will be held rigidly and the upper end of the rod will spring back to its original position upon release. If the point is still in thawed soil, the entire rod will turn and much less spring will be noted upon release. Probing in gravel is unreliable, and in coarse gravel it is impossible due to obstruction by the larger stones. When probing results appear indefinite, they may often be checked by borings with soil augers. In general, the two methods when applied in fine-grained soils give results which compare closely enough so that neither method can be discarded as unsatisfactory for observations at depths up to 10 ft. Valuable supplementary data can be obtained by probing, especially during the "freeze-up" season in the fall. The greatest value of probing is for reconnaissance and for investigation of sites where continuous records over long periods of time are not contemplated. Recent field tests indicate that probing by pneumatic drills is more effective in frozen ground than hand-driven probe rods.

III Area No. 2 -- Runway Foundation Studies

11. DESCRIPTION. Test sections in Area No. 2 were constructed to determine the effect of various pavement types, insulators, and base courses on ground temperatures. They include the 26 runway test sections listed in Table III-2 and shown on Plate III-6 and Figures III-6 and III-7.

12. INSTALLATION OF OBSERVATIONAL FACILITIES. Facilities are provided in Area No. 2 for observation of ground temperatures, groundwater levels, vertical movement of ground and test section surfaces, depth to permafrost by probing, and the taking of soil samples for moisture determinations. The location of each of these facilities is shown on Plate III-6. Sampling sleeves provided in paved test sections, for taking soil samples under pavement, have proved to be ineffective for sampling through the gravel backfill to the subgrade due to the caving action of the gravel. For this reason, the sampling sleeves have not been used. As an alternate method, test pits have been dug adjacent to the edge of

pavement in certain representative sections. Typical moisture-density relations for the sand and gravel fills of Areas Nos. 2 and 3 are shown in Plate III-24. Plate III-25 shows grain-size accumulation curves which are typical of the backfill materials in Areas Nos. 2 and 3. Observational facilities in Area No. 2 are, in general, similar in construction to those installed for similar purposes in Area No. 1, as described in this report.

TABLE III-2

FAIRBANKS RESEARCH AREA NO. 2
RUNWAY TEST SECTIONS

Sec. No.	Con- struc- tion Season	Surface	Base Course		Total Thick- ness, ft
			Type	Insulation	
RN-1	Summer	5-in. Asphalt	Sand and Gravel	None	12
RN-2	Summer	5-in. Asphalt	Sand and Gravel	None	8
RN-3	Summer	Gravel	Sand and Gravel	None	4
RN-4	Summer	5-in. Asphalt	Sand and Gravel	None	4
RN-5	Summer	5-in. Asphalt	Sand and Gravel	3-in. P.C. Foamglas	4
RN-6	Summer	5-in. Asphalt	Sand and Gravel	6-in. P.C. Foamglas	4
RN-7	Summer	5-in. Asphalt	Sand and Gravel	6-in. Cell Concrete	4
RN-8	Summer	5-in. Asphalt	Sand and Gravel	6-in. Cell Concrete (low density)	4
RN-9	Summer	5-in. Asphalt	Sand and Gravel	12-in. Cell Concrete	4
RN-10	Winter	5-in. Asphalt	Sand and Gravel	6-in. Cell Concrete (low density)	4
RN-11	Winter	5-in. Asphalt	Sand and Gravel	6-in. P.C. Foamglas	4
RN-12	Summer	5-in. Asphalt	Sand and Gravel	None	2
RN-13	Summer	6-in. Concrete	Sand and Gravel	None	2
RN-14	Summer	5-in. Asphalt	Sand and Gravel	None	10
RN-15	Summer	5-in. Asphalt	Sand and Gravel	None	6
RN-16	Summer	6-in. Concrete	Sand and Gravel	None	6
RN-17	Summer	6-in. Concrete	Sand and Gravel	None	4
RN-18	Summer	12-in. Concrete	Sand and Gravel	None	4
RN-19	Summer	5-in. Asphalt	Sand and Gravel	6-in. Compacted Spruce Logs and Branches	4
RN-20	Summer	5-in. Asphalt	Sand and Gravel	6-in. Compacted Moss	4
RN-21	Summer	5-in. Asphalt	Sand and Gravel	6-in. Zonolite Concrete	4
RN-22	Summer	5-in. Asphalt	Sand	None	4
RN-23	Summer	6-in. Concrete	Sand	None	4
RN-24	Spring	6-in. Concrete	Sand and Gravel	None	4
RN-25	Spring	5-in. Asphalt	Sand and Gravel	None	4
RN-26	Spring	Gravel	Sand and Gravel	None	4

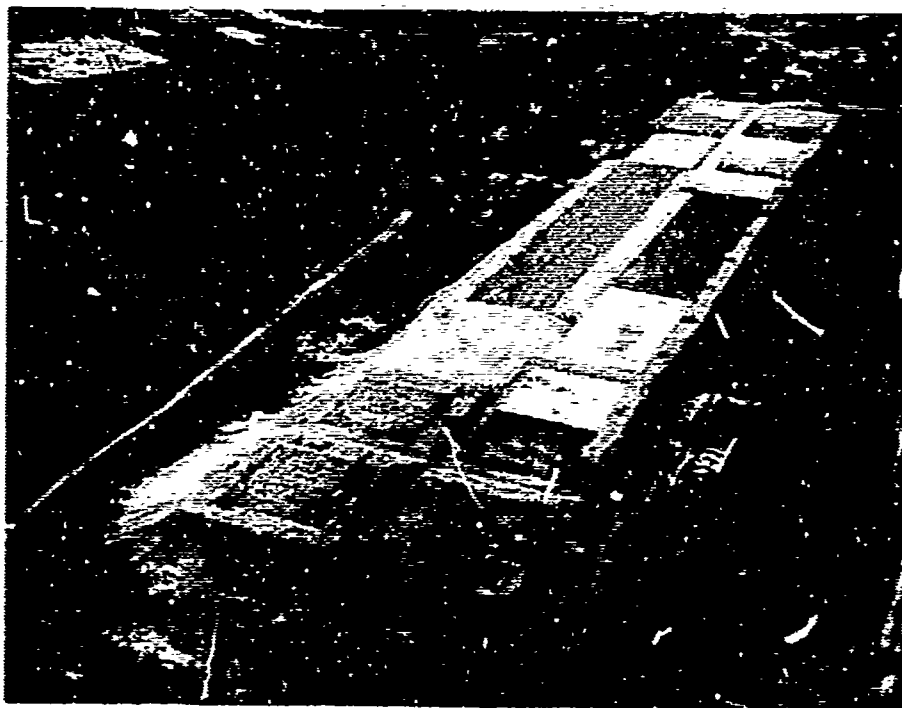

Figure III-6. Area 2 General view looking south, Area 2 in foreground, Area 3 in upper right background. October 1946

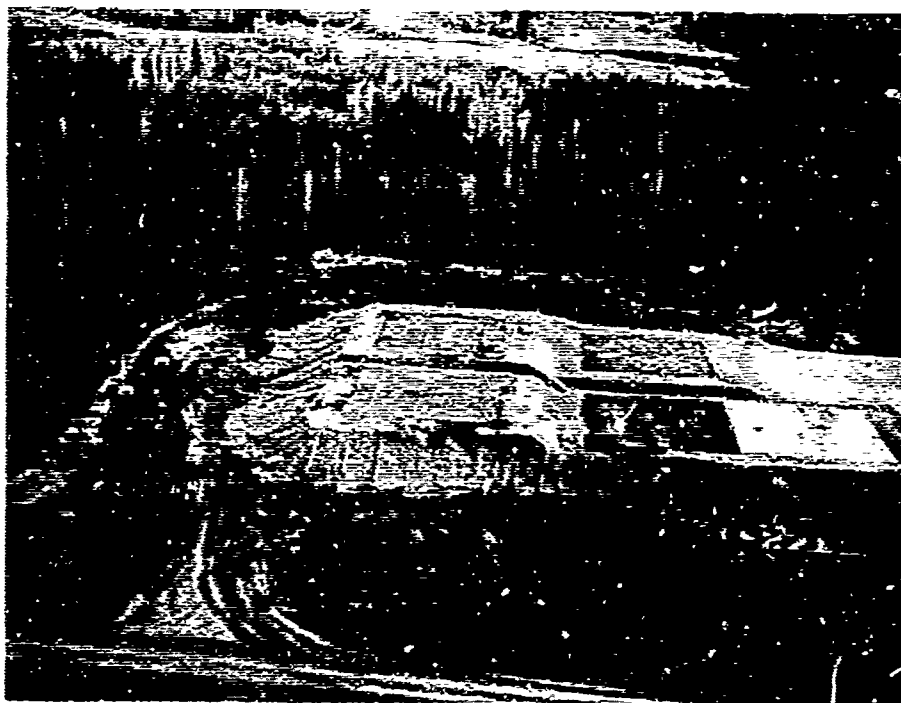

Figure III-7. Area 2. Close-up of thick gravel fills, Sections RN-1, RN-2, RN-14, RN-15 and RN-16. October 1946

Figure III-8. Area 2
Stripping thawed surface
material with dragline
July 1946

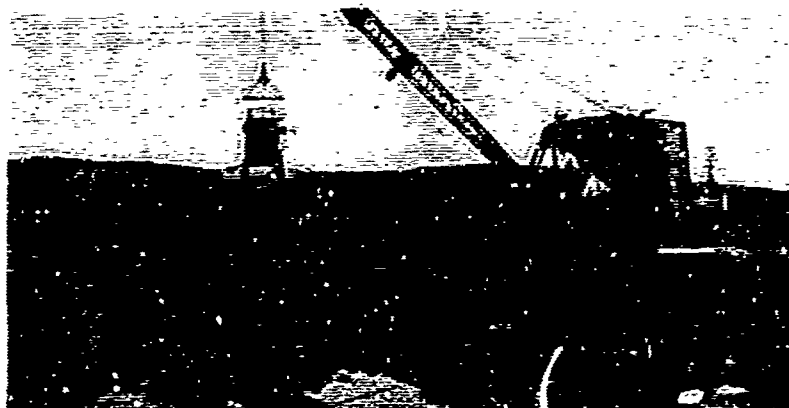

Figure III-9. Area 2
Hand drainage of subgrade
during spring thaw.
June 1946

Figure III-10. Area 2
Junction between Sections
RN-19 at left and RN-20 at
right. Note spruce boughs
and moss insulating layers
prior to compaction by
placement of gravel fill.
July 1946



Figure III-11. Area 2
insulating layers in place.
Foamglas in Section RN-5,
near center; spruce boughs
in Section RN-19, left fore-
ground; moss in Section
RN-20, middle foreground; and
zonolite concrete in Section
RN-21, right foreground.
July 1946



Figure III-12. Area 2
Placing cell concrete insulation
in Section RN-7.
July 1946



Figure III-13. Area 2
Base course construction. Due to
unstable condition of subbase during
spring construction, backfill was
extended by end dumping. July 1946



Figure III-14. Area 2
Six-inch layer of Foamglas insulation
consisting of two courses each 3 in.
thick sealed with tar. March 1947

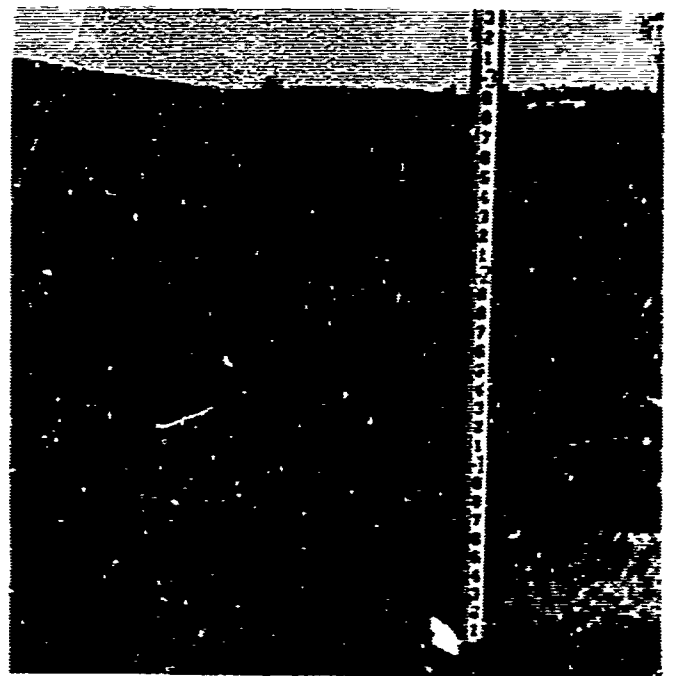

Figure III-15. Area 2
Sectional view of Section RN-9. Note
insulating layer of cell concrete
exposed below gravel fill. October 1946

13. GROUND TEMPERATURE OBSERVATIONS. Ground temperatures are observed in Area No. 2 at the center of each of the 26 test sections and at 4 points on the center line of the area. Observations were started at holes R-201 and R-204 in February of 1946, at holes RN-10 and RN-11 in July of 1947, and at all other holes in Area No. 2 in September or October 1946, so that, in general, a record of observations covering a period of two years is available. Readings were taken daily until April 1947 and weekly from that date to 31 October 1948. Ground frost data collected in Area No. 2 have been summarized and are presented graphically in Plates III-26 to III-36, inclusive, which show the position of the 0°C isotherm under each section at various times during the period of record. On the basis of observations and tests performed, it is considered that natural variables such as climatic conditions, moisture content, and density of soil remain quite uniform throughout the small area involved in Area No. 2, so that any differences in heat flow observed may be considered to result from the differences in design of the various sections. Since each section represents an individual test, the 0°C isotherm has been plotted separately for each section as a straight line rather than attempting to draw a continuous isotherm for the full length of the area. Ground temperatures are observed in each section at only one point which is located at the center of the section in each case. Holes R-201 and R-204, located in natural ground on the center line at either end of Area No. 2, provide a comparison with ground temperatures under natural conditions. The position of the 0°C isotherm for these holes is given by note on each of the sectional drawings.

14. GROUNDWATER OBSERVATIONS. Groundwater levels are observed at weekly intervals at 6 points in Area No. 2. Present data are for periods from 8 June to 25 September 1946, from 27 May to 29 October 1947, and from 26 May to 27 October 1948.

15. NATURAL MOISTURE CONTENT AND DRY DENSITY OF BACKFILL AND SUBGRADE. Test pits were dug during late September and early October 1947 adjacent to the surfacing in Sections RN-2, RN-6, RN-9, RN-18 and RN-21 in order to secure undisturbed samples for the determination of natural moisture content and dry field density of soils underlying the test sections. The test pits were located and dug in such a manner as to make it possible to secure samples as far under the sections as possible without disturbing the surfacing. The data obtained were used in making calculations of depth of thaw. For all samples from the five test pits in Area No. 2, the moisture content of the gravel fill ranged from 1.9 to 6.0 percent, with the greater number falling between the limits of 2.5 to 4.5 percent. The dry density of the gravel varied from 133 to 144, and averaged 141 lb per cu ft. The highest density of the natural soil was encountered immediately beneath the gravel fill in each case. This condition is apparently due to compaction by overlying gravel fill and is noted to depths of from 1.5 to 2.0 ft below the bottom of the gravel. The average dry density in this zone for all test pits was 95.1 lb per cu ft, the maximum density of 108.2 occurring in Section RN-9. Below this zone, the density decreased and averaged 78.7 lb per cu ft for all samples taken. The average moisture content of the gravel fill for all test pits was found to be 3 percent, indicating that the material is quite free draining. A marked increase in moisture content is noted upon entering the natural soil subgrade, but no definite trend toward increase or decrease of moisture content can be detected at increasing depths into the subgrade. Two samples, one in Section RN-2 with a moisture content of 57.8 percent and one in Section RN-18 with a moisture content of 81.9 percent, are noted to depart radically from the general average. All other samples range between 22.5 and 54.0 percent and average 37.9 percent. Peat in varying stages of decomposition has been noted to have varying qualities of absorption due to the cellular structure of organic material which may hold free water within the cells. Both of the samples noted above for widely divergent moisture content contained peat which might explain this condition. It is noted that the cell concrete insulating layer in Section RN-9 had a moisture

content of 40.4 percent, and the concrete layer in Section RN-21 had a moisture content of 74.0 percent. Both are embedded in gravel having a moisture content of about 4.6 percent.

16. **VERTICAL MOVEMENT OF GROUND AND TEST SECTION SURFACES.** Vertical movement was observed in Area No. 2 at three points in natural ground along the eastward side of the area and at five points on the surface of each test section to compare the extent of vertical movement which may be expected in several types of construction and in the natural ground surface. The various types of construction studied in the test sections are also shown on Plate III-6. Level observations were made of each point at intervals during the period from 23 November 1946 to 10 November 1948.

IV Area No. 3.-- Building and Piling Studies

17. **DESCRIPTION.** Test facilities in this area for testing the effect on ground temperatures of buildings with various types of foundation construction, and the stability of piles placed to varying depths into permafrost, include the buildings shown in Table III-3, on Plates III-7 and III-37, and in Figure III-16. Buildings 1 to 8, inclusive, are 16 by 16 ft and are used as test buildings only. Buildings 9 and 10, 32 ft square, are utilized as residences and Building 11, also 32 ft square, as a garage, in addition to serving as test buildings. Test piles to determine the depth necessary to prevent seasonal heaving and settlement are placed at varying depths to penetrate permafrost to distances 0, 1/2, 1, 1-1/2, 2, 2-1/2, and 3 times the thickness of the active layer. See Figures III-17 through III-26.

18. **INSTALLATION OF OBSERVATIONAL FACILITIES.** Facilities are provided in Area No. 3 for the observation of ground temperatures, groundwater levels, depth to permafrost by probing, the taking of soil samples for moisture determinations, and vertical movement of buildings, piles and ground surface. The locations of these facilities are shown on Plate III-7. Vertical movement observation points for buildings consist of 20d spikes driven into the sills at each corner. For piles, the observation point consists of a 20d spike driven into the pile at about 14 in. above the normal ground surface. Ground temperatures pertinent to the buildings are observed at switch panels within the buildings in lieu of switches in junction boxes used for taking readings at other thermocouple installations. The spacing and depths of each thermocouple installation, together with other information pertinent to the installations, are shown in Plate III-37. During September 1947, swellometers to observe the

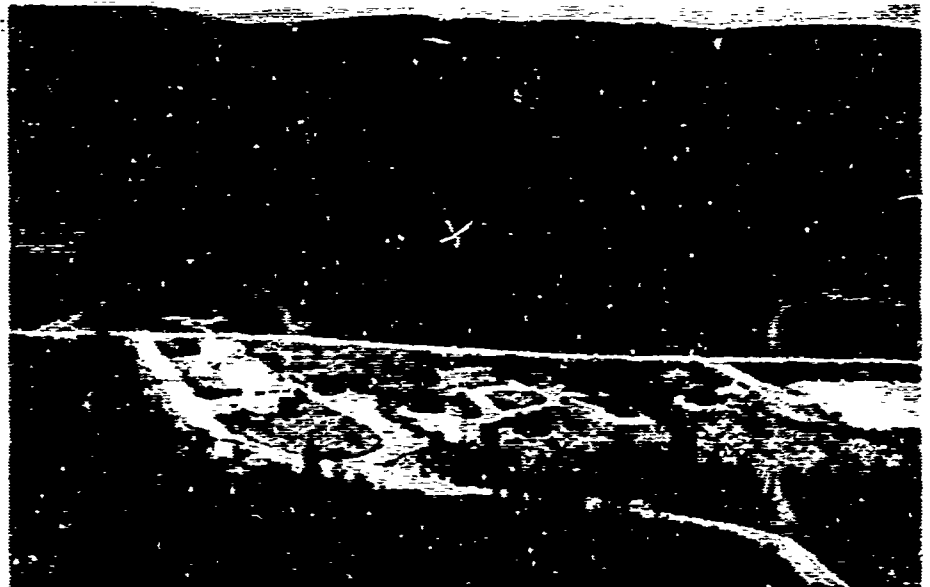

Figure III-16. Area 3
General view of test buildings. July 1948

TABLE III-3

FAIRBANKS RESEARCH AREA NO. 3
TEST BUILDINGS 1 to 11

Bldg. No.	Type of Floor	Foundation		Insulation in Foundation
		Material	Thickness	
1	Concrete	Sand and Gravel	4 ft	None
2	Insulated wood	Sand and Gravel	4 ft	None
3	Insulated wood	Sand and Gravel	2 ft	None
4	Insulated wood	Sand and Gravel	6 ft	None
5	Insulated wood	Sand and Gravel	4 ft	6-in. Cell Con- crete
6		Post and Pads	Beams 2 ft above ground surface, with- out skirting	None
7	Insulated wood	Post and Pads	Beams 2 ft above ground surface, with skirting	None
8	Insulated wood	Mud Sills	On the natural ground surface	None
9	Insulated wood on upper con- crete slab	2 Concrete slabs separ- ated by concrete piers 3 ft high on 5-ft gravel fill		None
10	Insulated wood with air space	Piling approx- imately 4 ft above natural ground		None
11	Concrete slab containing layer of continuous hollow tile open to air at both ends	Gravel Fill	5 ft	None



Figure III-17. Area 3
Foundation of Test Building
No. 1 with 4-in. concrete floor
slab in place. Building No. 2 in
background. September 1946

Figure III-18. Area 3
Test Building No. 5 with wood
sills placed directly on gravel
fill and wood floor completed.
Typical construction for Build-
ings Nos. 2, 3, 4 and 5.
September 1946



Figure III-19. Area 3
Test Building No. 6 with wood
floor completed. Not to be
skirted. September 1946

Figure III-20. Area 3
Test Building No. 7 with floor
completed and skirting in place
September 1946



Figure III-21. Area 3
 Test Building No. 8 with pads and
 sills in place on ground surface.
 August 1946



Figure III-22. Area 3
 Rock wool insulation in floor of
 test building. Typical construction
 for Buildings Nos. 2, 3, 5, 6 and 7.
 July 1946

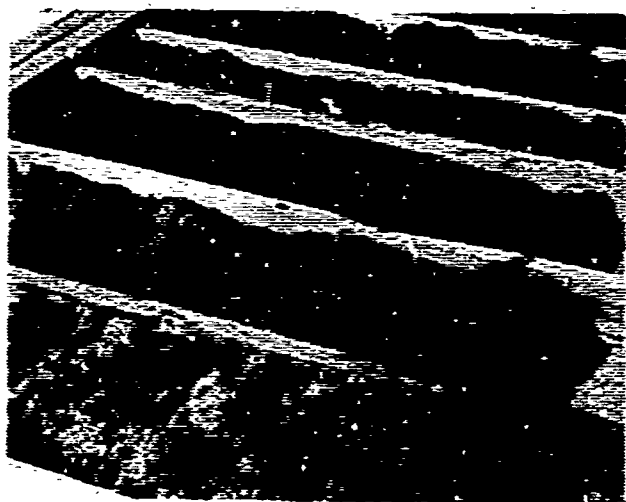
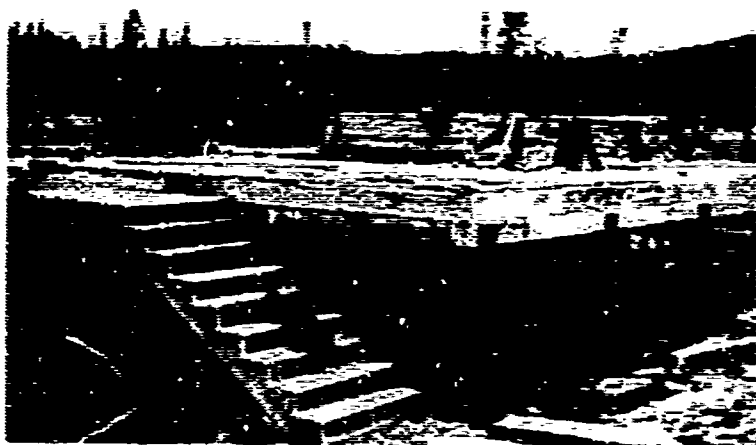

Figure III-23. Area 3
 General view of Buildings 9, 10
 and 11 from rear to foreground.
 July 1946



Figure III-24. Area 3
 Test Building No. 10 with
 rough floor in place. Note
 composite wooden beams and
 treated wood piling supports.
 August 1947



upward vertical movement of the soil at various depths below the ground surface, were installed in Area No. 3 at three locations as shown on Plate III-7. Essentially, a swellometer consists of eight wood rods, 1-in. square and of varying lengths, each of which is firmly fastened to a hollow prismatic base one foot long and a ninth rod set in a solid base. See Plate III-38.

The rods are assembled and lubricated in such a way that they may slide freely in a vertical direction and move independently of each other. The base of each rod is left unlubricated and may be roughened to promote a good bond with the surrounding soil so that the movement of each rod is determined by the movement of the soil at the depth to which the base is placed. The movement of each rod is observed at its upper end which protrudes above the ground surface.

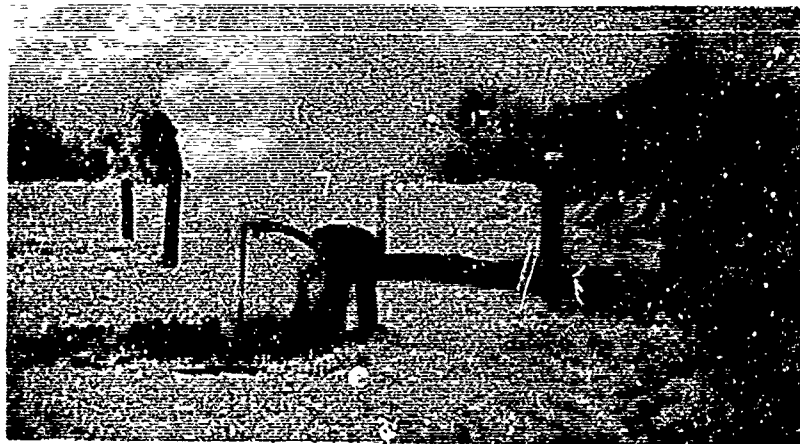

Figure III-25. Area 3

General view of test pile section showing a steam point in operation. The Herman Nelson heater on the right was used to warm up a dragline engine.

December 1946

The rods are assembled and lubricated in such a way that they may slide freely in a vertical direction and move independently of each other. The base of each rod is left unlubricated and may be roughened to promote a good bond with the surrounding soil so that the movement of each rod is determined by the movement of the soil at the depth to which the base is placed. The movement of each rod is observed at its upper end which protrudes above the ground surface.



Figure III-26. Area 3

Placing a test pile into a thawed hole. December 1946

19. GROUND TEMPERATURE OBSERVATIONS.

Ground temperatures are observed weekly at 3 points in natural ground and under Test Buildings 1 to 8 in Area No. 3 at points indicated on Plate III-7. Beginning on 14 October 1946, these buildings were heated to maintain a continuous temperature of $+15^{\circ}\text{C}$ until 1 January 1947, at which time it had become apparent that no thaw would be caused under certain of the buildings by this temperature and the inside temperature was raised to $+20^{\circ}\text{C}$. Ground isotherms have been plotted for each of the buildings to show a north-south section at the center line of the building. Plates III-39 to III-49, inclusive, show these data plotted at various times during the period of record.

20. GROUNDWATER OBSERVATIONS.

Groundwater levels are observed weekly at 4 points in Area No. 3, as shown on Plate III-7. Present data cover periods from 8 June to 25 September 1946, from 27 May to 29 October 1947, and from 26 May 1948 to 3 November 1948. It may be noted on the plates showing ground temperature observations during the winter months that thawed zones which had about the same shape each year developed under certain buildings such as 7 and 8, and, in some cases, increased in size during the season. While no definite proof is available, it is believed that these thawed zones carry groundwater when soil layers just under the surface are frozen. The movement of water through

cracks, crevices and polygon channels tends to keep the ground from freezing.

21. NATURAL MOISTURE OF SUBGRADE. In order to secure information concerning the natural moisture content of soils in Area No. 3, auger borings were made in late September 1947 from the surface down to permafrost at points B-101, B-103 and B-104 in natural ground as shown on Plate III-7, and from the top of subgrade down to permafrost under each of Buildings 1 to 8 inclusive. For buildings on gravel fill, a 20-in. metal pipe was placed to extend from the top of fill through the fill to the top of subgrade to permit access to the subgrade for auger borings. Typical moisture data for the building area are shown in Plate III-50.



Figure III-27. Area 3
Placing fabricated steel vertical
movement observation point in the
ground adjacent to a test pile.
February 1947

shown on Plate III-7. The objective of these observations is to determine the vertical movement of the natural ground surface, to compare the vertical movement of buildings on various types of foundations, and to test the stability of piles placed to varying depths into permafrost. Twenty-one observations on points B-101, B-102, B-104 and B-105 in natural ground were made at intervals between 22 November 1946 and 8 November 1948, fifteen to twenty-one observations were made on test buildings between 8 November 1946 and 8 November 1948, and twenty observations were made on and beside the test piles between 14 January 1947 and 6 November 1948. Observations of ground temperatures and settlement of the Navy monotube test piles were made as required.

23. NAVY MONOTUBE TEST PILING. In order to assist the Bureau of Yards and Docks, Department of the Navy, in the testing of monotube steel piling placed in frozen ground, space was made available for a test installation of this type of piling. The installation was performed by personnel and equipment of the Post Engineer, Ladd Air Force Base, under supervision of the Department of the Navy. The Permafrost Field Office assisted in the

22. VERTICAL MOVEMENT OF GROUND AND TEST STRUCTURES. Vertical movement is observed in Area No. 3 at four points in natural ground, on the sills at each of the four corners of Test Buildings 1 to 11, on 17 piles supporting Building 10, at 15 points on the concrete floor of Building 11, on each of 24 test piles, and at a point on the ground beside each of the 24 test piles. Locations of the observation points are

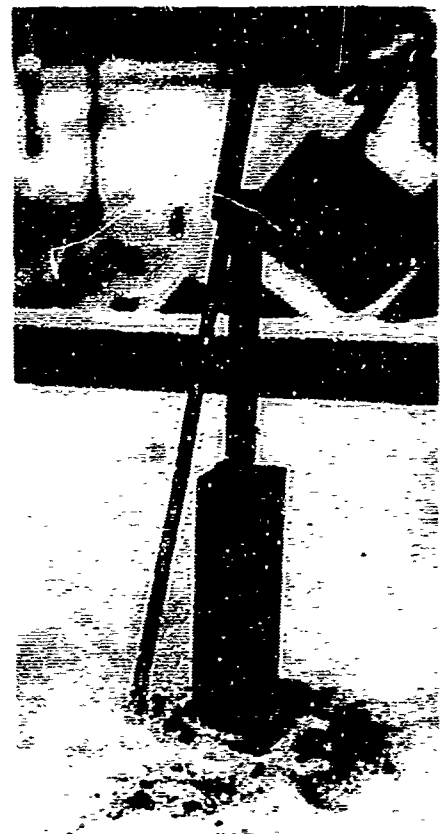

Figure III-28. Area 3
One of the 5 swellometers
installed in the test pile
area. December 1947

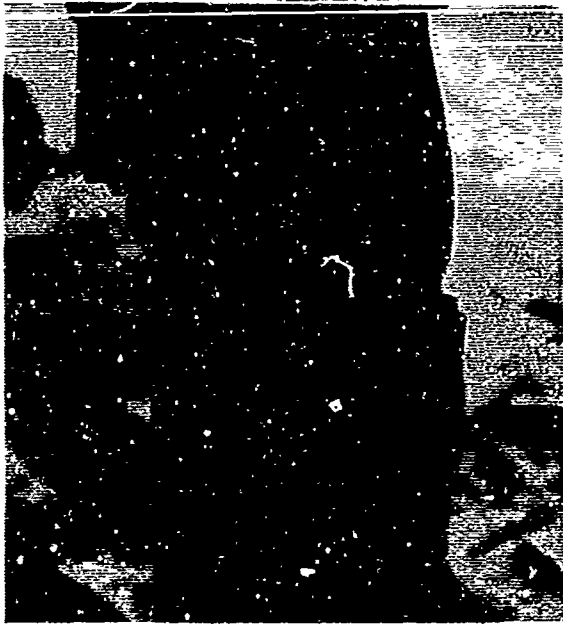

Figure III-29. Area 3
Detail of monotube Navy test pile
and temperature pipe.
November 1947

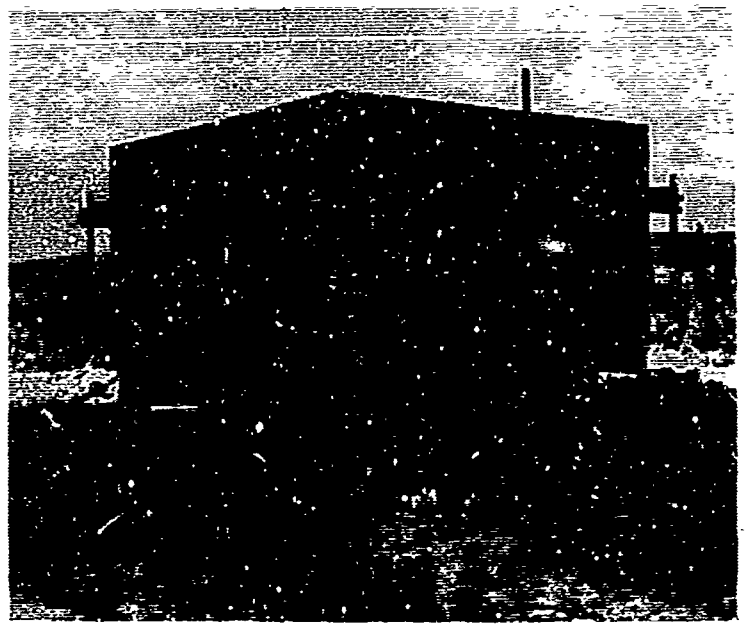

Figure III-30. Area 3
Loading platform for monotube test
piling. December 1947

planning and field supervision of the work and thermocouple assemblies were made up by the St. Paul District for the observation of ground temperatures adjacent to the piles. The installation consists of one 60-ft and one 40-ft pile which jointly support a bin in which a gravel load is placed. The piles were placed in holes preformed by steam thawing, during the period 13 to 20 November 1947. The loading bin with supporting steel members was completed on 12 December 1947. A total load of 114 tons was placed on the piles in December 1947. Installations for observing vertical movement of the ground surface and for observing groundwater levels in Area No. 3 are similar to those in Area No. 1, as described previously in this report. The following quotation is the report of 3 June 1948 from the Field Operations Branch of the Permafrost Division, St. Paul District, Corps of Engineers to the Officer in Charge, Arctic Test Section, U. S. Navy, Fairbanks, Alaska concerning test loading of monotube piles:

"1. Reference is made to previous correspondence on the above subject describing the installation of two Monotube Test Piles in the Permafrost Research Area near Fairbanks, Alaska by the Post Engineer, Ladd Air Force Base and the Permafrost Division in cooperation with your organization. The following is a summary of the sequence of operations and observations obtained in connection with the loading of these piles. The data is assembled on the inclosed drawing 'Vertical Movement and Ground Temperature Chart-Monotube Test Piles'. (Plate III-51 of this report.)

"2. Two piles, one 40 feet and the other 60 feet long, were placed in holes preformed by steam thawing, during the period 13 to 20 November 1947. On 12 December 1947, after the test piles had been installed for 23 days, the construction of the bin to carry the test load of gravel was completed, with the bin and the supporting steel beams in place atop the two piles. Calculated total weight of the bin and supporting members was 7.11 tons. At the time of

completion of the bin, ground temperatures adjacent to both piles were returning to normal after having been raised during the installation of the piles by steam jetting. Temperatures above zero degrees Centigrade were recorded between 2 and 45 feet at the 60-foot pile and between 4 and 21 feet at the 40-foot pile. Total settlement up to this date was 0.079 foot for the 60-foot pile and 0.031 foot for the 40-foot pile. There was no appreciable change in elevation following erection of the bin. By 19 December 1947, the piling appeared to be stabilized, with no settlement observed between 12 December and 19 December 1947. Temperatures of 0° C. or colder were recorded for the lower 30 feet of the 60-foot pile and for the entire depth of the 40-foot pile. On 20 December 1947, approximately 107 tons of gravel were placed in the bin, bringing the total load to 114 tons. Upon release of the screw jacks in place at the four corners to prevent tipping of the bin, immediate settlement was observed, and by 22 December 1947 the 60 and 40-foot piles had settled 0.126 foot and 0.106 foot respectively and were exerting pressure on the jacks at the corners of the bin. The jacks were lowered again on 22 December and an immediate settlement of 0.009 foot and 0.012 foot on the 60-foot and 40-foot piles respectively was observed. This rapid settlement continued until 26 December when the total observed settlement since loading was 0.214 foot on the 60-foot pile and 0.197 foot on the 40-foot pile. At this point, ground temperatures had not stabilized and normal cooling was continuing. After the jacks were released on 22 December 1947, they were not disturbed until 16 March 1948. Between these dates, a portion of the load was transferred to the jacks, through settlement of the piles, at an indeterminate rate. Between 26 December 1947 and 16 January 1948, total settlement was 0.023 foot and 0.018 foot on the 60-foot and 40-foot piles respectively, and ground temperatures continued a gradual decline on both piles until they reached a minimum on 10 January 1948, after which time a gradual daily increase in temperatures was noted. No temperatures above 0° C. were recorded between 30 December 1947 and 21 January 1948 at the 60-foot pile and at the 40-foot pile between 20 December 1947 and 21 January 1948. Between 16 and 30 January, accelerated settlement accompanied by a general rise in ground temperatures was observed at both piles and resulted in the distribution of a greater proportion of the load to the jacks at the corners. Total settlement between these dates was 0.065 foot and 0.053 foot at the 60-foot and 40-foot piles respectively. Elevations of both piles remained virtually constant during the period 30 January 1948 to 12 March 1948, although minor temperature variations were noted. The load remained constant and no change was made in the jacks which were carrying an undetermined portion of the load.

"3. Since it was apparent that the two piles could not sustain the load of 114 tons and hydraulic jacks with indicator dials or other suitable means were not available to apply and measure the load in increments, it was decided to remove the major portion of the gravel and to reload in increments one foot in depth over the bin's floor surface and thereby determine the maximum load capable of being supported by the piles. Accordingly, on 15 March 1948, all but 2 feet of the gravel was removed from the bin, decreasing the load to approximately 34 tons. Since 7 March, a gradual lowering in ground temperatures had been noted, and on the date the gravel was removed, the ground temperatures observed were generally +0.1° C., with the exception of the upper and lower extremities of the piles where the

temperatures were below zero. On 16 March, approximately 24 hours after the gravel had been removed, a slight but definite drop in temperature was noted and, in every case, ground temperatures were at zero or minus 0.1°C . throughout the center portions of the piles. No appreciable change in elevation occurred upon decreasing the load. On 16 March 1948, the jacks were lowered for the first time since 22 December 1947; there were no significant changes in temperature or elevation. No portion of the load was supported by the jacks between 16 March and 6 April 1948. On 18 March 1948, the gravel was brought to a depth of 3 feet, increasing the load to 47 tons. No appreciable change in temperature or elevation resulted. Elevations on 19 March showed an equal settlement of 0.008 foot on both piles and no further increments were added until 23 March 1948. Between 20 March and 22 March 1948, a temperature rise from minus 0.1°C . to plus 0.2°C . took place in the central sections of both piles. The small vertical movement observed during the period 19 March to 23 March is likely due to the limitations of accuracy of level observations. On 23 March 1948, an increment of one foot of gravel brought the total load to 60.5 tons. Application of this additional load was accompanied by a slight rise in temperature throughout the length of both piles; there was no observed change in elevation. On 25 March, the gravel was brought to a depth of 5 feet or a total load of 74 tons. No significant changes in elevation or temperature were noted until 23 March when temperature at both piles showed an increase of from 0.1 to 0.3°C . Largest increases were in the central portion of the 40 foot pile. After 26 March, a gradual decrease in temperatures took place in both piles. On 29 March, eight inches of gravel were added bringing the total load to approximately 83 tons. Settlement in the order of 0.004 foot occurred immediately, but both piles remained fairly stable until 1 April when a rapidly accelerating settlement started and continued to its maximum on 12 April when the steel beams came to rest on the ground surface at the south side of the bin and on two jacks which had not been removed from the north side. Temperature observations continued since 12 April indicate a general and progressive rise in ground temperatures. At present, temperatures are above 0°C . throughout the length of both piles.

"4. The observations outlined above indicate that the piles were relatively stable and, for the short period of observation, successfully supported a load of approximately 74 tons. with the application of additional load bringing the surcharge to 82.8 tons, the yield point was reached and progressive accelerating settlement occurred. The bond between the soil material and the pile surface (tangential adfreezing strength) has been computed for 1 April 1948 when the piles were supporting a total load of 82.8 tons; there had been no appreciable movement for three days following application of the final load increment and, with the exception of approximately seven feet on the 40 foot pile, ground temperatures adjacent to the piles were at 0°C . or colder. The quantity of soil moisture which remained thawed at the range of temperature observed adjacent to the piles is indeterminate from the available data, however, for the purpose of calculating tangential adfreezing strength, ground at 0°C . or colder is considered to be frozen.

Weight of bin in place 14220 lb.
 Weight of 1513.90 cu. ft. gravel at 100 lbs/cu.ft. 151390 lb.
 Total Load 165610 lb.

Surface area of 40' pile in frozen ground 89 sq. ft.
 Surface area of 60' pile in frozen ground 194 sq. ft.
 Total Area 283 sq. ft.

Tangential adfreezing strength 4.06 lb. per
 sq. in.

"5. Except for the observation that pile failure and rapid settlement occurred at a specific loading only general conclusions can be drawn from the data collected thus far. The soils underlying the test site are frozen to a depth of approximately 150 feet and, in the natural state, contain large amounts of moisture, mostly in the form of ice which serves to bond the soil particles into a dense mass capable of great resistance to penetration. Piling placed in permafrost must, therefore, be placed in holes preformed by thawing or some other method. If thawed, the thermal regime is disturbed and the soil loses its structure becoming more or less a fluid, depending upon the amount of moisture present. Piling introduced into the ground under these conditions do not develop their full strength until the adjacent soil has refrozen and the thermal regime is re-established. In the vicinity of Fairbanks where the test is being conducted, the temperature of the permafrost at depths below the level of seasonal influence approaches the critical temperature of 0° C. and a considerable time is required for the natural 'reserve of cold' to overcome the effects of heat introduced for the formation of holes into which piles can be placed and to re-establish the thermal regime. Consideration of the inclosed drawing, which depicts graphically the vertical movement of the piles and concurrent ground temperatures, indicates that the pile movement beginning after stabilization of ground temperatures to comparatively normal conditions will generally be accompanied by a rise in temperature which it is thought reflects the thawing of ice forming the surface bond between the pile and the enclosing material. In order to extend and substantiate the data collected to date, it is planned to repeat the above test by reloading the piling with approximately 60 tons and observe their behavior over an extended period of six or more months. Upon completion of this phase of observations, the piles will again be gradually loaded to failure."

A review of this report indicates some doubt as to whether ground around the piling was entirely refrozen at the time of loading. Temperature observation equipment used is not necessarily accurate within 0.3° C and the silt soil in the area can be expected to have 0.1° to 0.2° C depression of the freezing point. Thus, temperatures of -0.4° C do not necessarily indicate that the ground was frozen. This office is now studying the possibility of using pressure cells to indicate ground freezing. The computed tangential adfreezing strength of 4.06 psi is based on the assumption that all of the load was carried by bond between the piling and the adjacent ground and that the ground was frozen. It neglects any point bearing capacity which would be a substantial amount in frozen ground.

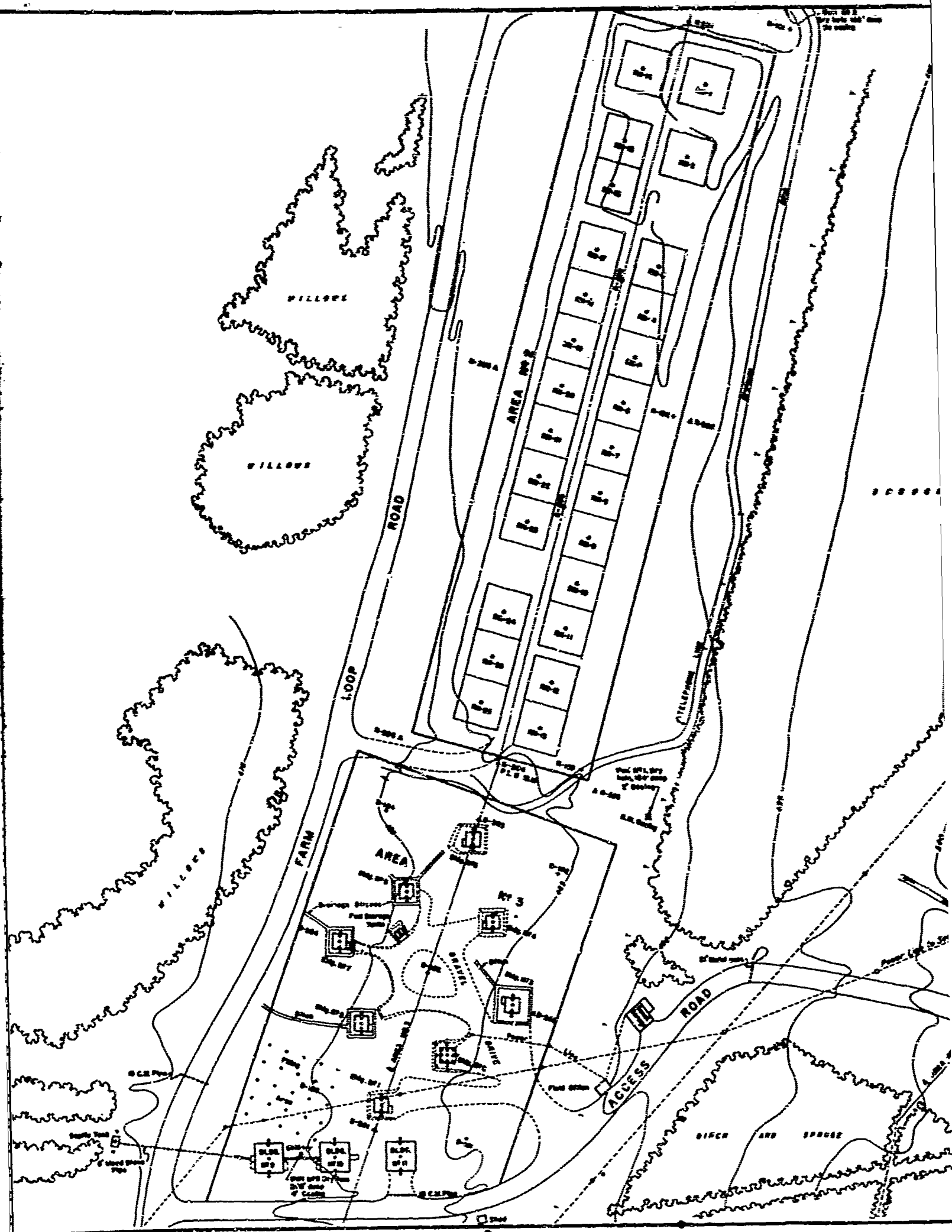

A

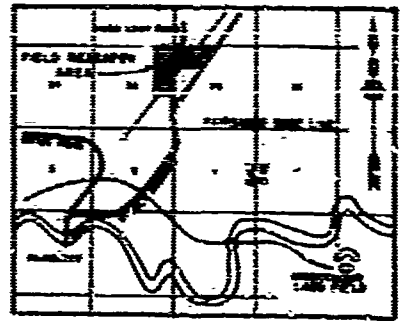

VENTY MAP

SCALE IN MILES

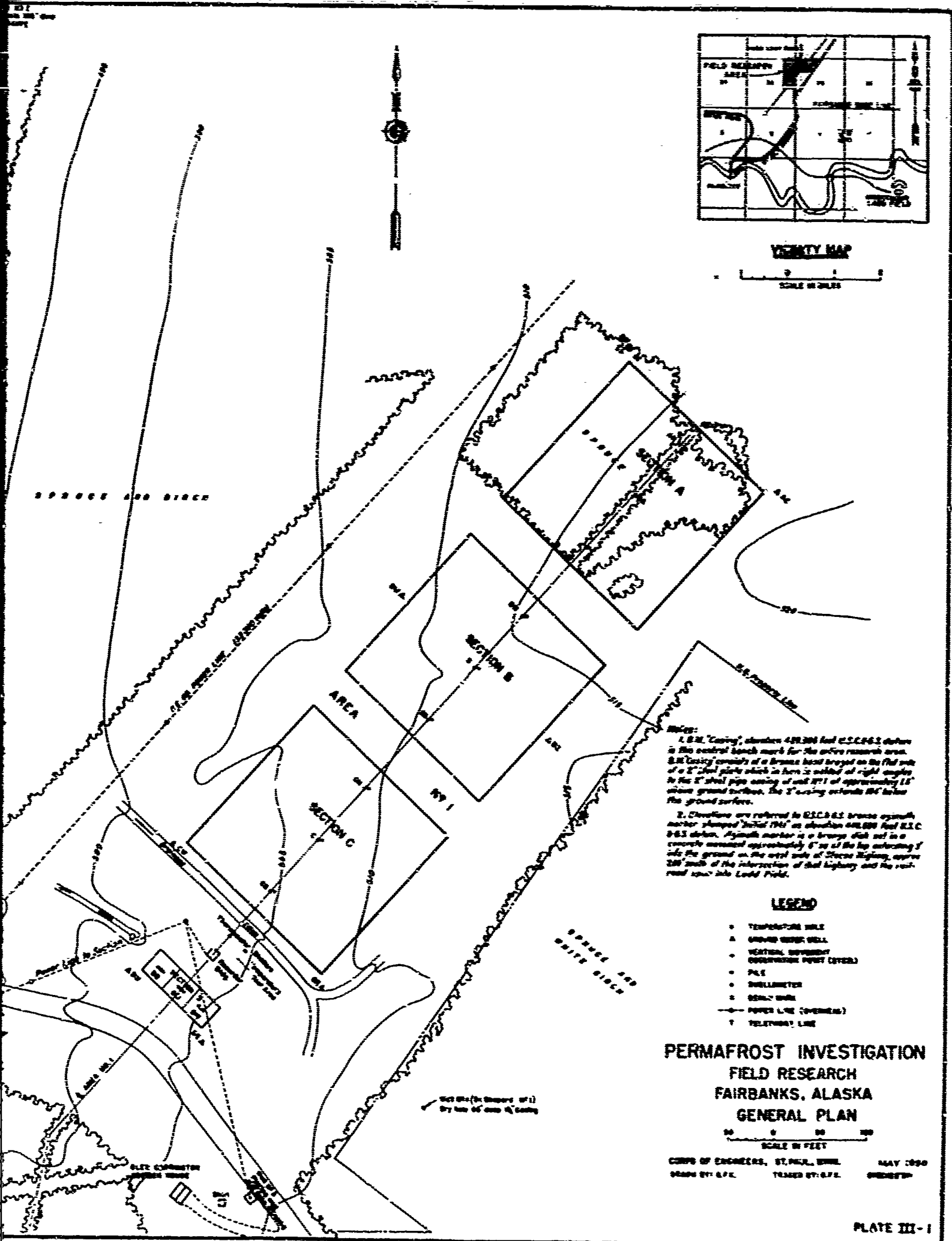

Notes:
 1. B.M. "Casing", elevation 491.200 feet U.S.C. 8-63 datum is the central bench mark for the entire research area. B.M. "Casing" consists of a bronze base braced on the flat side of a 2" steel plate which in turn is welded at right angles to the 2" steel pipe casing of wall 2" of approximately 15' above ground surface. The 2" casing extends 24" below the ground surface.
 2. Elevations are referred to U.S.C. 8-63 datum. Bench mark is a bronze disk set in a concrete mound approximately 6" up at the top extending 3' into the ground on the west side of State Highway, across 200' south of the intersection of that highway and the railroad spur into Ladd Field.

LEGEND

- TEMPERATURE WELL
- ▲ GROUND WATER WELL
- VERTICAL MOVEMENT OBSERVATION POINT COVERED
- PILE
- THERMOMETER
- BENCH MARK
- POWER LINE (OVERHEAD)
- ⋈ TELEGRAPH LINE

**PERMAFROST INVESTIGATION
 FIELD RESEARCH
 FAIRBANKS, ALASKA
 GENERAL PLAN**

SCALE IN FEET

CORP. OF ENGINEERS, ST. PAUL, MINN. MAY 1950
 DRAWN BY: G.F.L. TRACED BY: G.F.L. CHECKED BY: G.F.L.

1947

OCTOBER

NOVEMBER

DECEMBER

JANUARY

FEBRUARY

MARCH

MEAN DAILY A

TEMPERATURE - DEGREES FAHRENHEIT

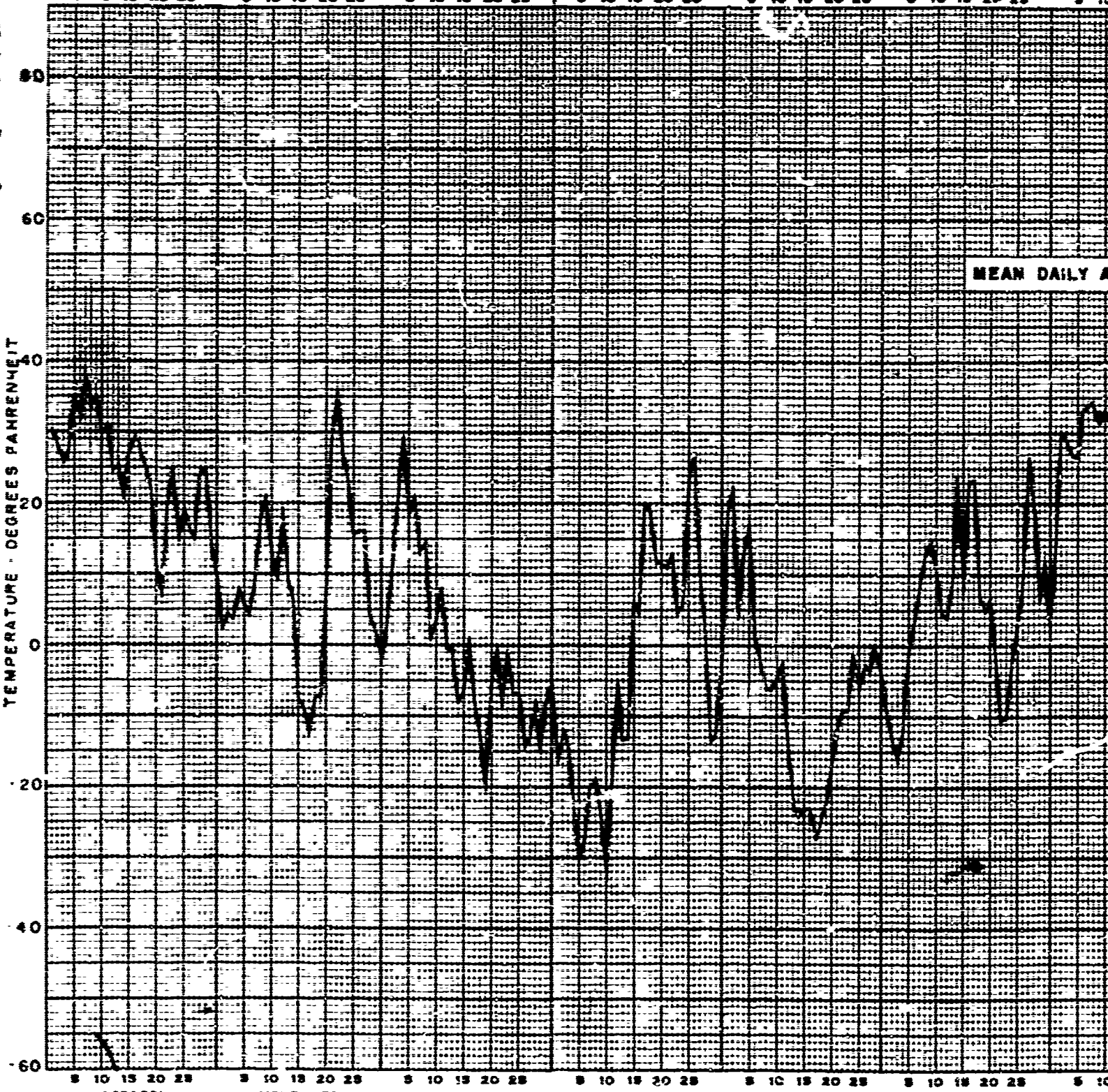

A

1948

FEBRUARY MARCH APRIL MAY JUNE JULY AUGUST
5 10 15 20 25 5 10 15 20 25 5 10 15 20 25 5 10 15 20 25 5 10 15 20 25 5 10 15 20 25 5 10 15 20 25

MEAN DAILY AIR TEMPERATURE

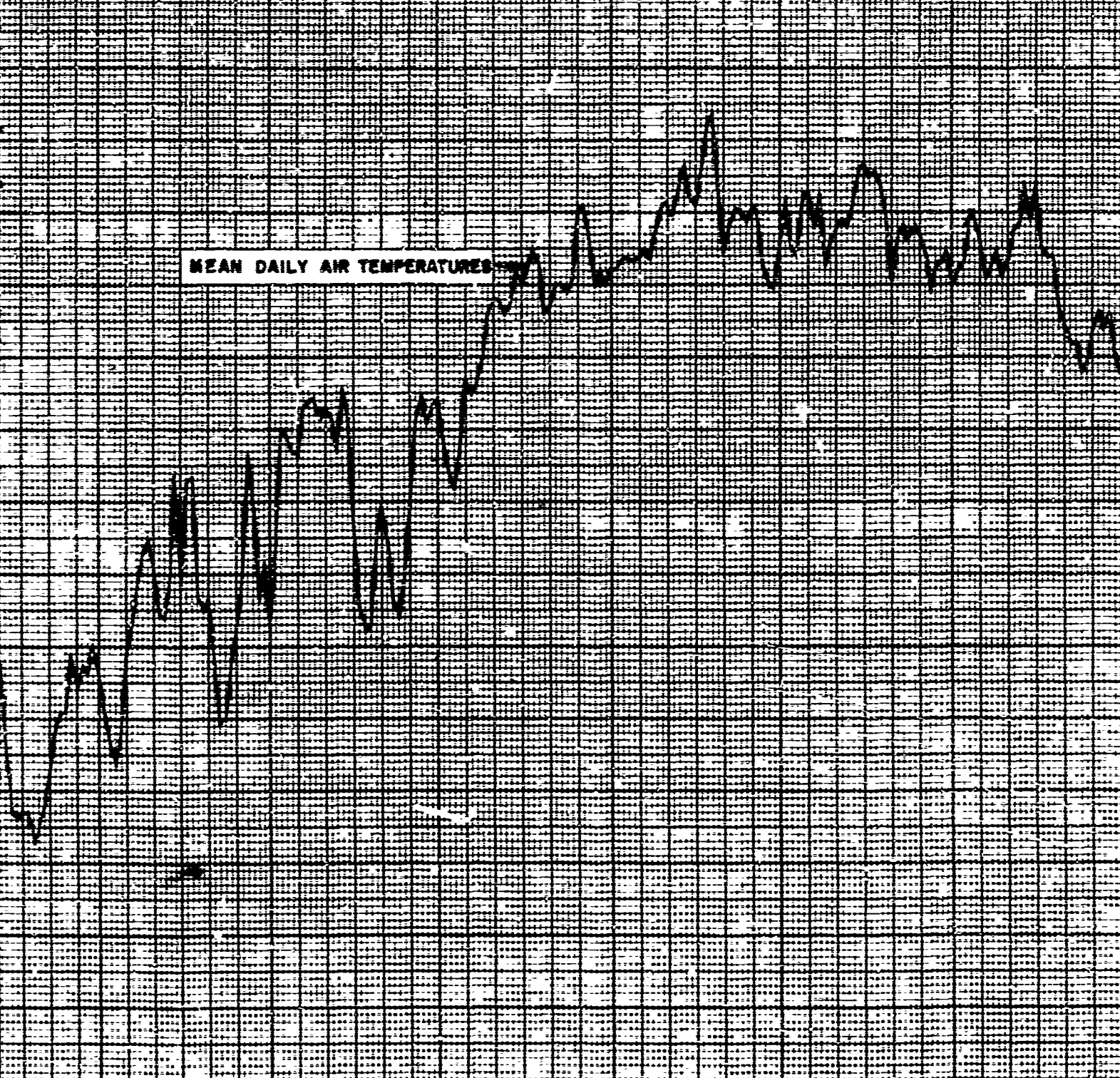

FEBRUARY MARCH APRIL MAY JUNE JULY AUGUST
5 10 15 20 25 5 10 15 20 25 5 10 15 20 25 5 10 15 20 25 5 10 15 20 25 5 10 15 20 25

B

1948

JUNE JULY AUGUST SEPTEMBER OCTOBER
20 25 5 10 15 20 25 5 10 15 20 25 5 10 15 20 25 5 10 15 20 25 5 10 15 20 25

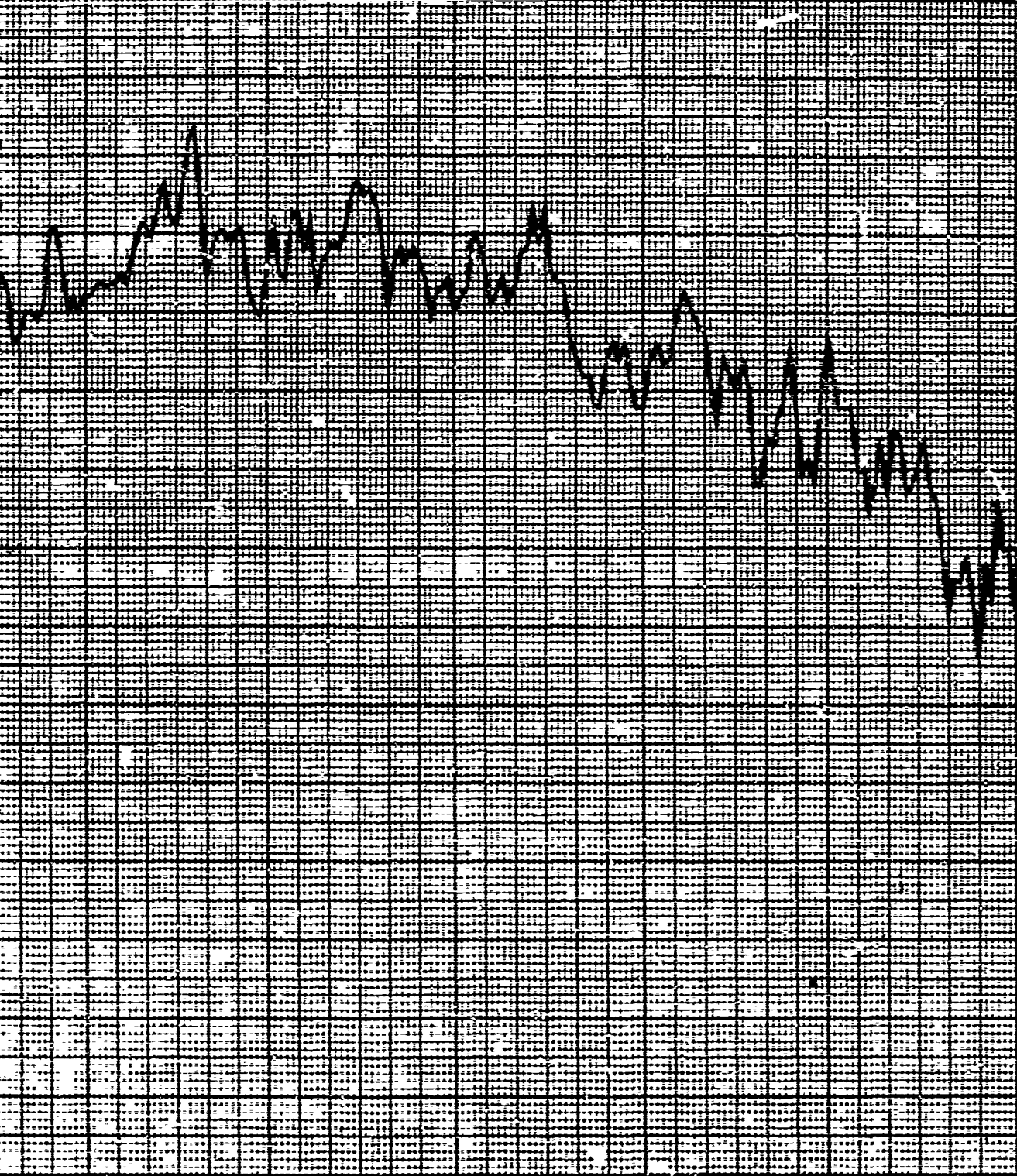

TEMPERATURE - DEGREES CENTIGRADE

JUNE JULY AUGUST SEPTEMBER OCTOBER
20 25 5 10 15 20 25 5 10 15 20 25 5 10 15 20 25 5 10 15 20 25

C

PERMAFROST INVESTIGATION
FIELD RESEARCH FAIRBANKS, ALASKA
AIR TEMPERATURES
CORPS OF ENGINEERS, ST. PAUL, MINN. MAY 1950

PLATE III-2

1947

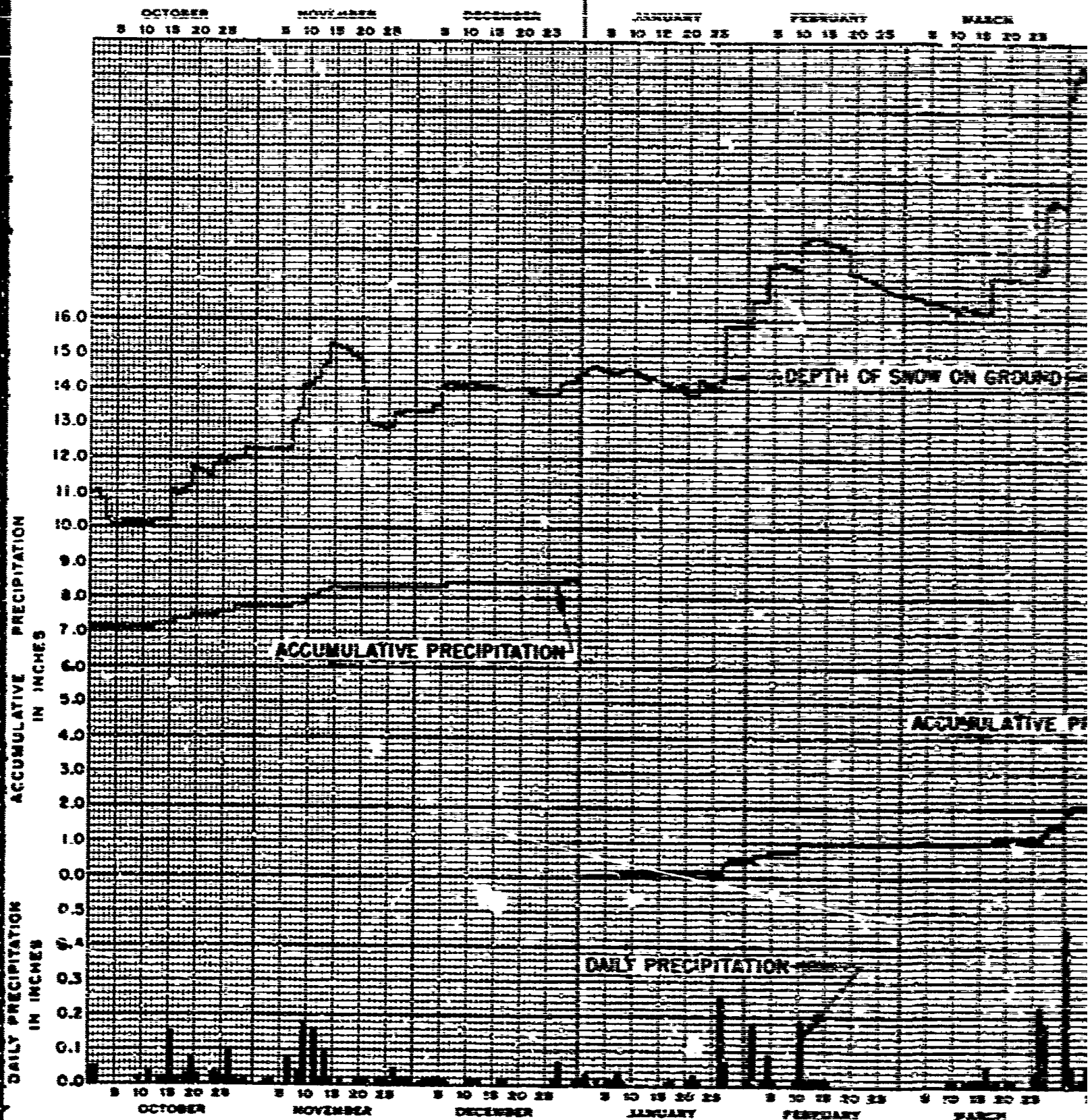

1948

JANUARY 5 10 15 20 25 FEBRUARY 5 10 15 20 25 MARCH 5 10 15 20 25 APRIL 5 10 15 20 25 MAY 5 10 15 20 25 JUNE 5 10 15 20 25 JULY 5 10 15 20 25

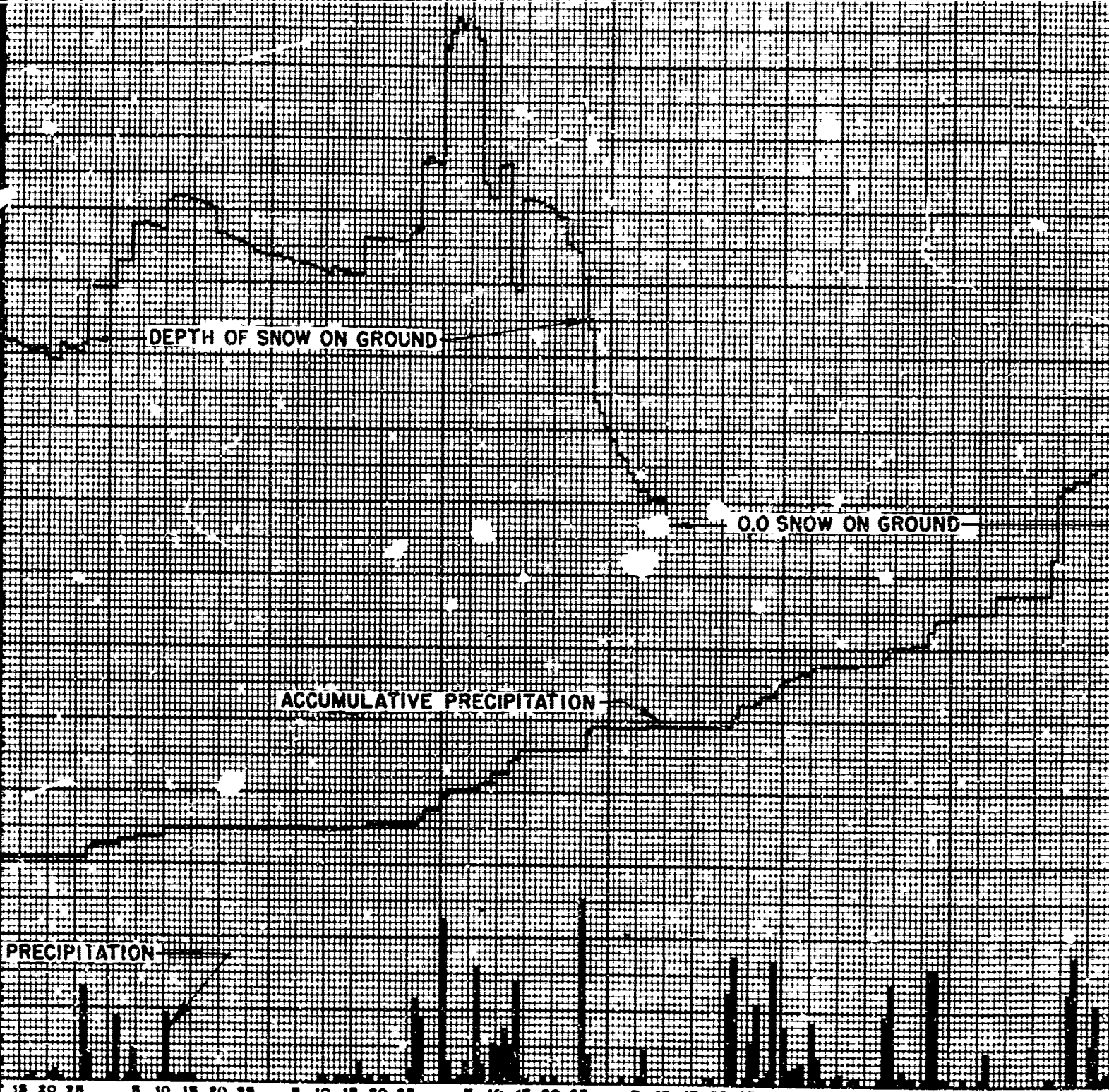

JANUARY 5 10 15 20 25 FEBRUARY 5 10 15 20 25 MARCH 5 10 15 20 25 APRIL 5 10 15 20 25 MAY 5 10 15 20 25 JUNE 5 10 15 20 25 JULY 5 10 15 20 25

X = TRACE

B

1948

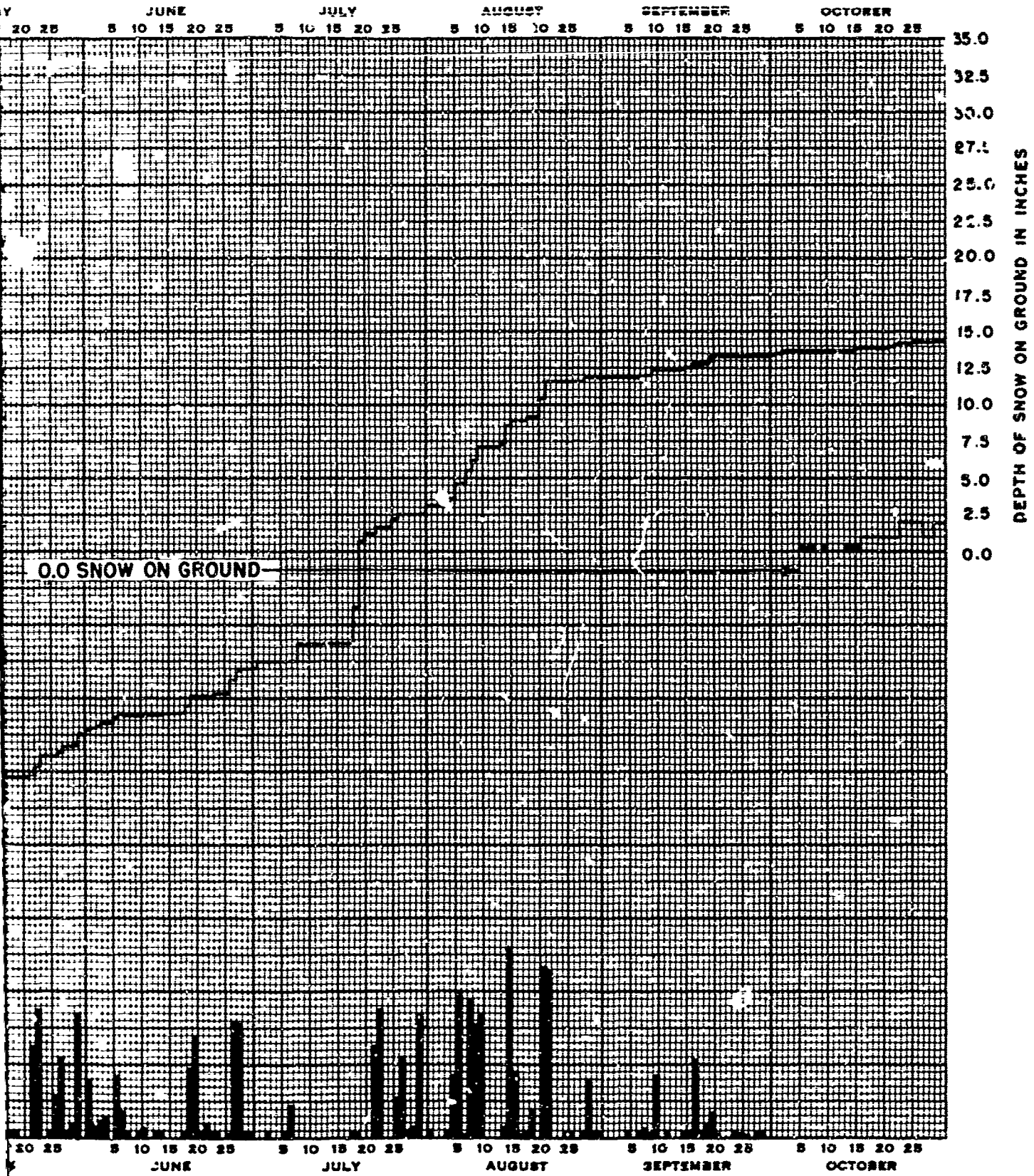

PERMAFROST INVESTIGATION
WEEKS FIELD - FAIRBANKS ALASKA
METEOROLOGICAL DATA
PRECIPITATION & SNOW COVER
CORPS OF ENGINEERS, ST. PAUL, MINN. MAY 1950

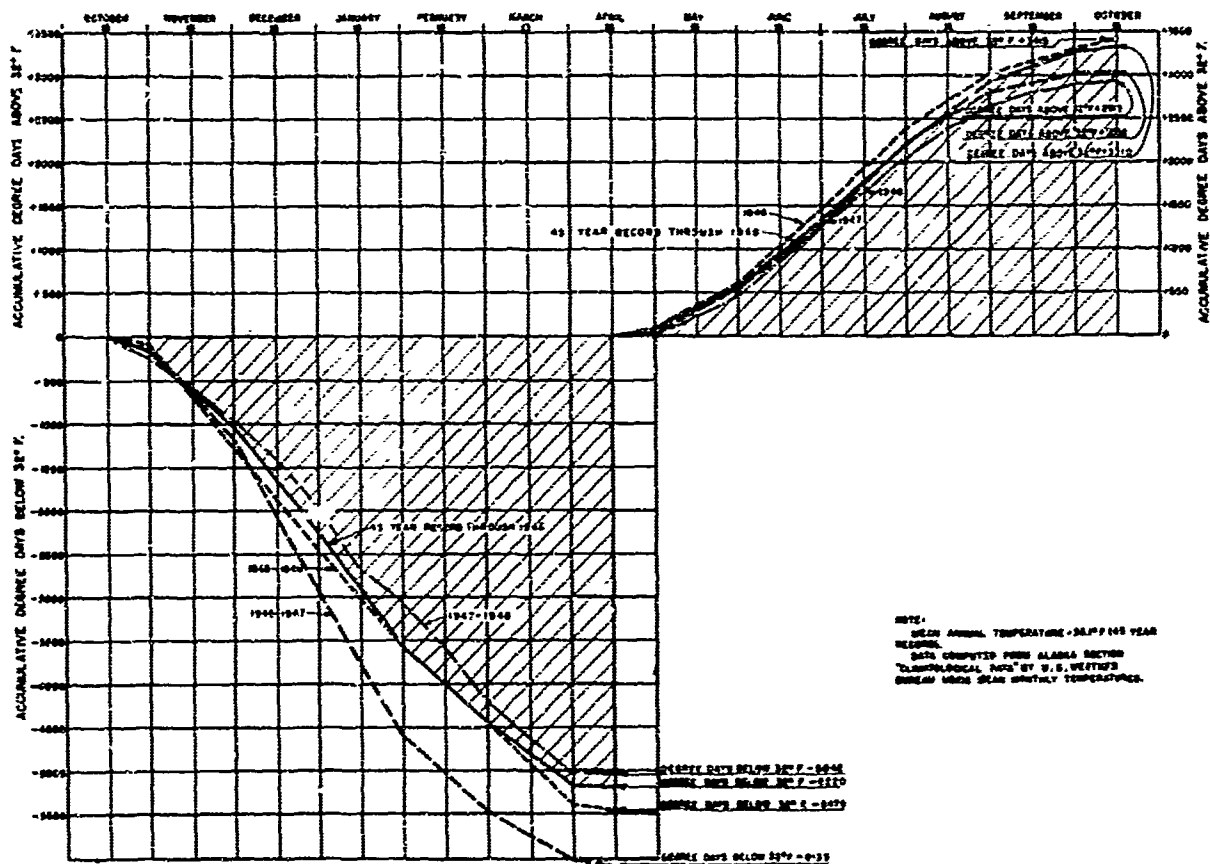

PERMAFROST INVESTIGATION
 METEOROLOGICAL STUDIES
 U. S. W. B. WEATHER STATION
 WEEKS FIELD - FAIRBANKS, ALASKA
 DEGREE DAYS ABOVE & BELOW 32° F.
 CORPS OF ENGINEERS, ST. PAUL, MINN. MAY 1950

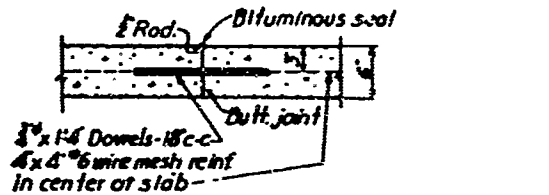
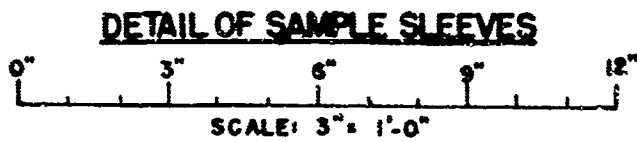
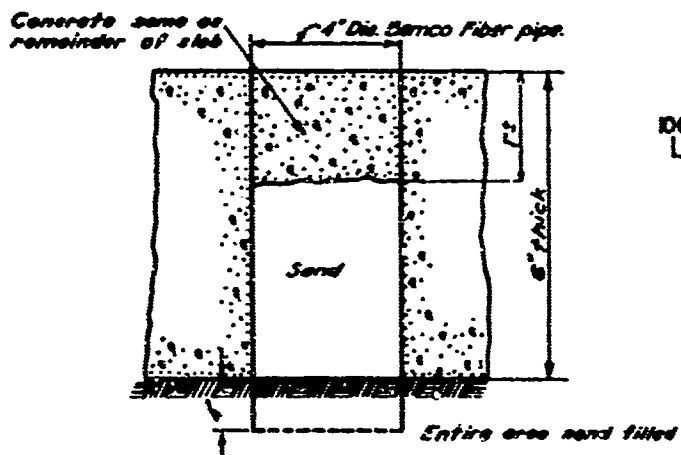
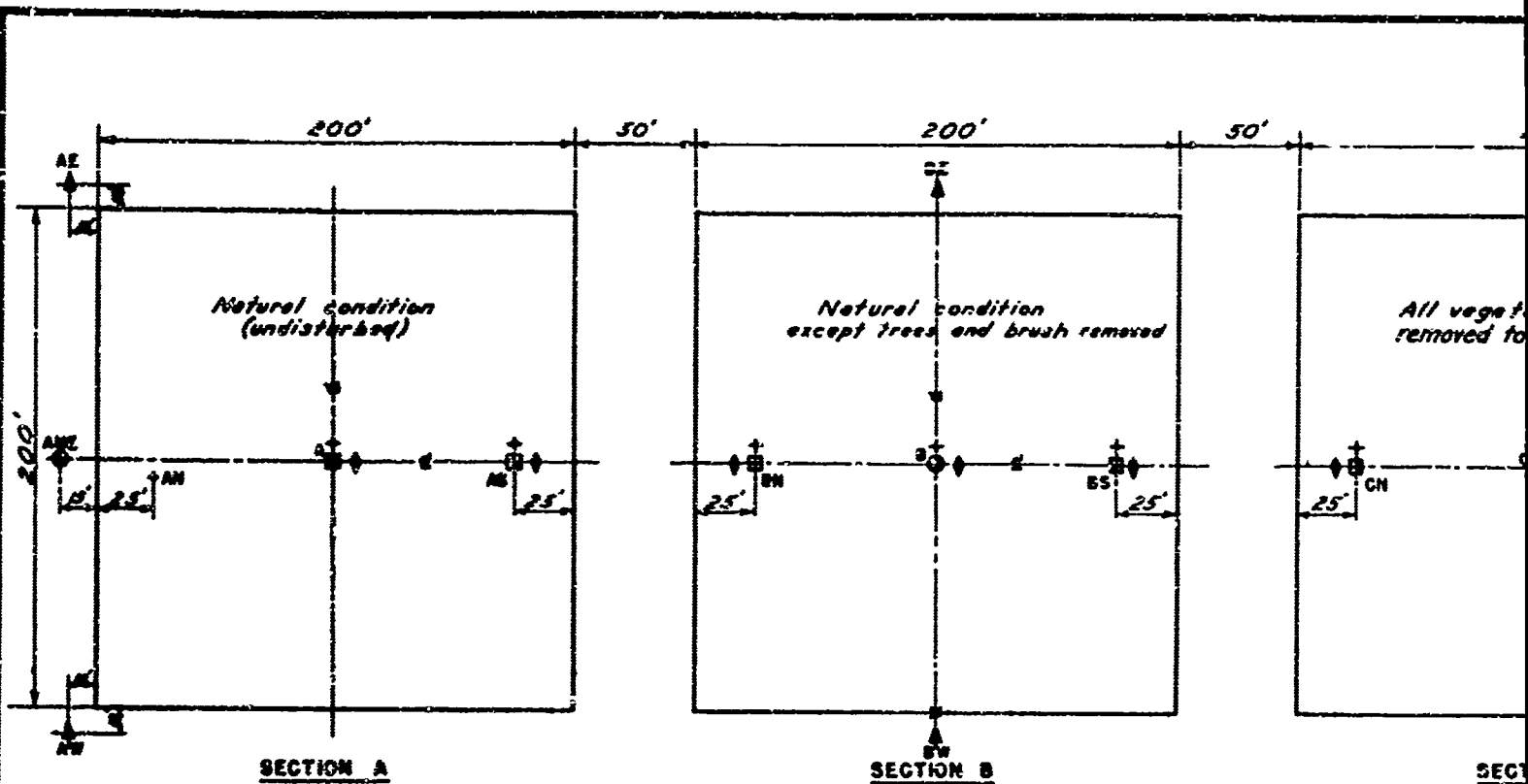

CONSTRUCTION JOINT

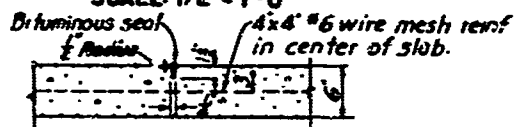

TRANSVERSE DUMMY JOINT



Transverse dummy joint

A



DETAIL OF DRAINAGE DITCH SECTION C

Drainage ditch as shown on section-C, location to be established in field.
Cut ditch 12' deep at origin in section C and maintain 0.5% grade to outfall at power line right of way

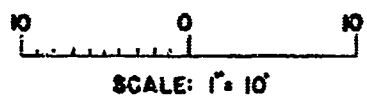
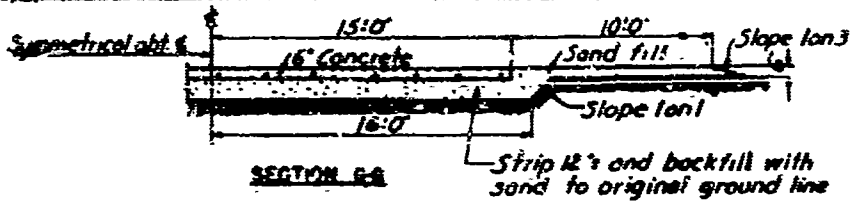

SCALE: 1" = 10'

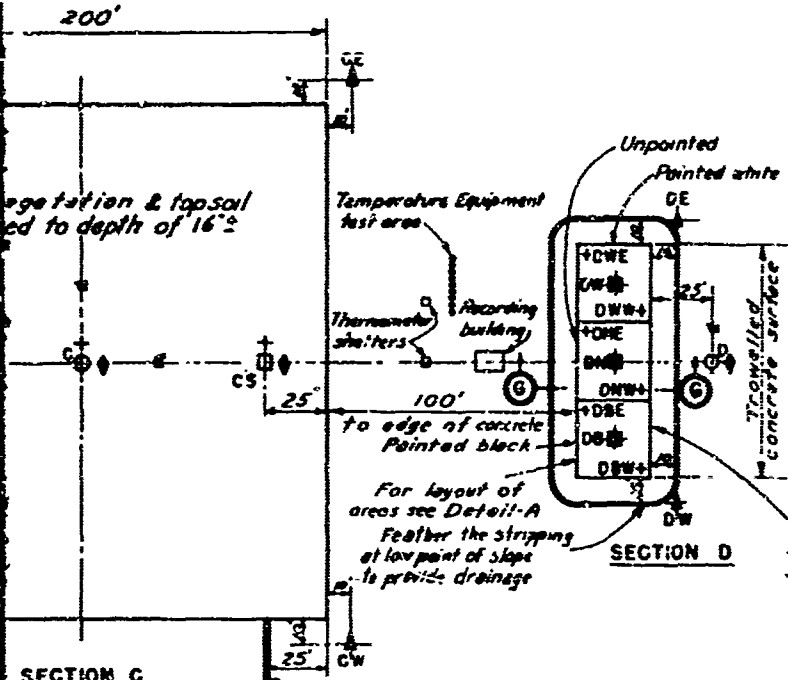
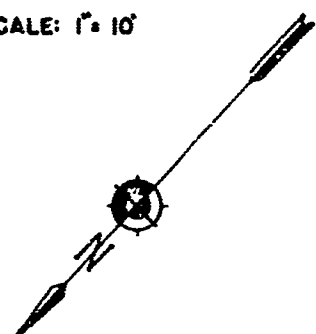

Drainage ditch to F.E. Co. power line R/W See detail.

SECTION C

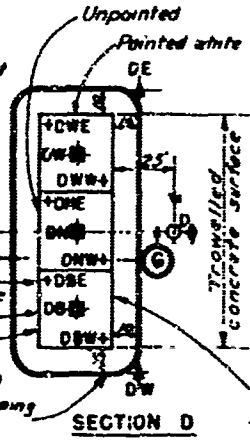

Remove vegetation & topsoil to depth of 12" & backfill with sand to original ground surface.

LEGEND

- ⊕ Core boring 30' deep
 - ⊗ Churn drill boring 30' deep
 - ⊙ Churn drill boring 15' deep
 - ⊕ Churn drill boring 10' deep - Ground water well
 - + Vertical movement observation point
 - ⊗ Bench mark
 - ⊖ Frost observation point
 - Sample sleeves for moisture determination
- } Ground temperature holes

General notes:
 Location of thermocouples in ground temperature holes. At the surface and at 3", 6", 9", 12", 15", 18", 21", 24", 27", 30", 33", 36", 39", 42", 45", 48", 51", 54", 57", and 60" below the surface.
 Location of thermocouples in ground temperature tubes. At the pavement surface and at 3", 6", 9", 12", 15", 18", 21", 24", 27", 30", 33", 36", 39", 42", 45", 48", 51", 54", 57", and 60" below the pavement surface.

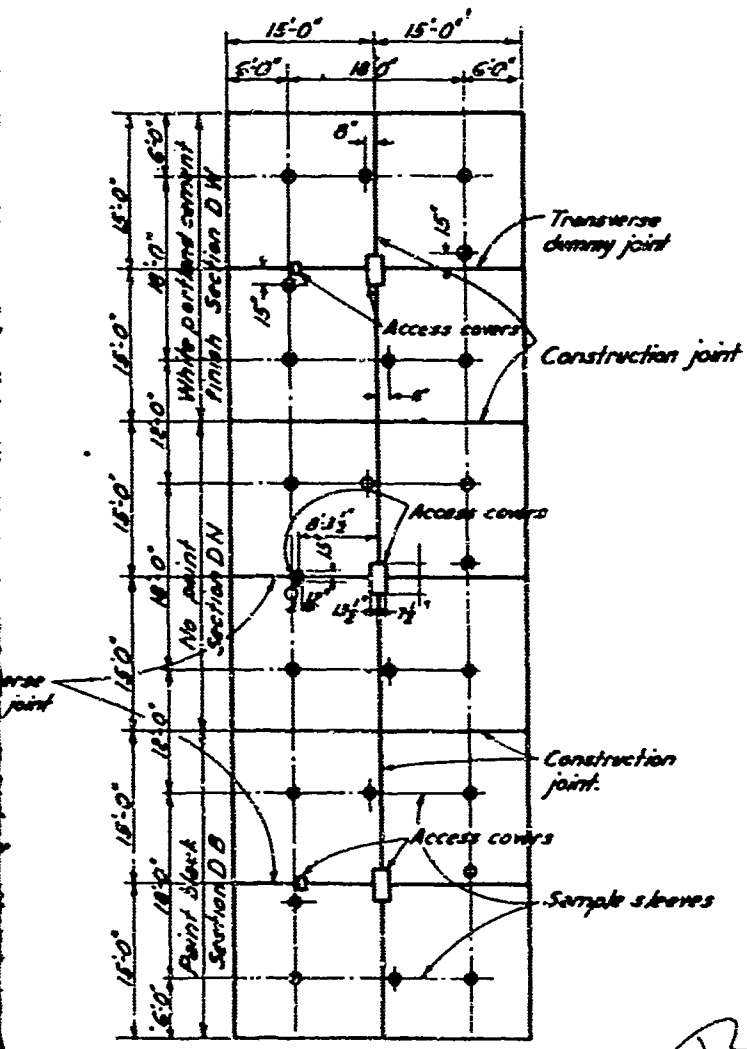

DETAIL "A"



B

**PERMAFROST INVESTIGATION
 FIELD RESEARCH
 FAIRBANKS, ALASKA
 AREA NO. 1
 GROUND AND PAVEMENT
 SURFACE STUDIES**

SCALE AS SHOWN
 CORPUS OF ENGINEERS ST PAUL, MINN RAY 1960
 DRAWN BY C.W.B. TRACED BY S.W.J. CHECKED BY:

New section temperature hole and design number

Original program boring hole log no.

Original program design number

RN-1	R-1	None (1)
RN-2	None	None (2)
RN-3	R-5	R-22
RN-4	R-6	None (3)
RN-5	R-7	R-13
RN-6	R-8	R-14
RN-7	R-9	R-15
RN-8	R-10	R-21
RN-9	R-11	R-6
RN-10 (6)	R-12 (5)	R-7
RN-11	R-13	R-23
RN-12	None	R-3
RN-13	None	R-18
RN-14	R-15	None (1)
RN-15	None	R-1
RN-16	None	R-15
RN-17	R-20	R-20
RN-18	R-21	None (4)
RN-19	R-22	R-26
RN-20	R-23	R-25
RN-21	R-24	R-11
RN-22	R-25	R-10
RN-23	R-26	R-9
RN-24	R-28	R-28
RN-25	R-29	R-29
RN-26	R-30	R-30

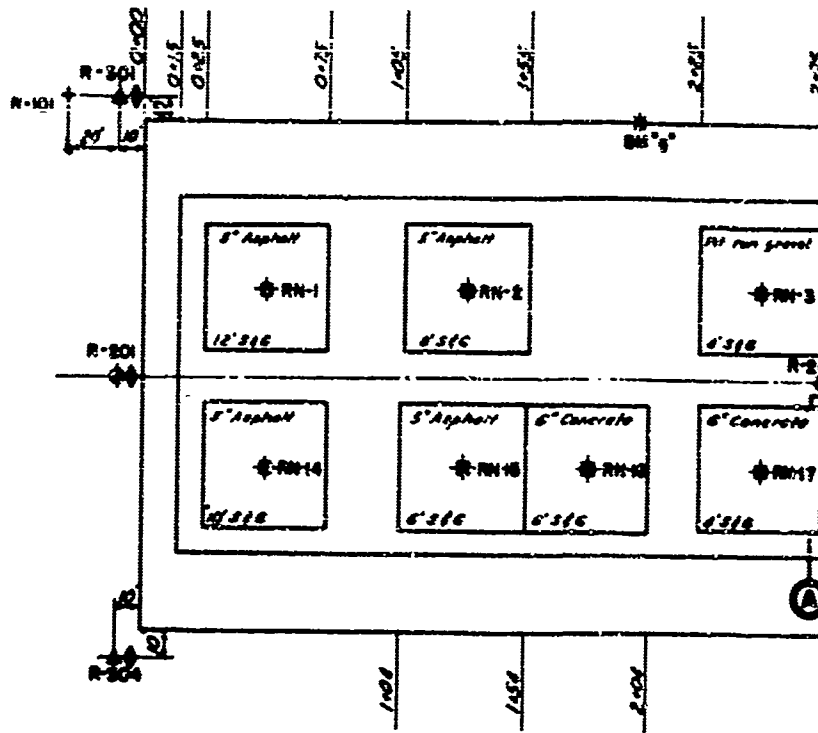

- (1) New section in program requested by L. J. Rice, Chief of Engineers.
- (2) Not in original program. Original R-24 revised to avoid duplication in design.
- (3) Not in original program. Original R-8 revised due to lack of sand.
- (4) Not in original program. Original R-5 revised to provide thicker pavement.
- (5) Original design R-12 was eliminated due to lack of foam compound for mixing cell concrete.
- (6) Changed from medium to low density cell concrete due to lack of sand.

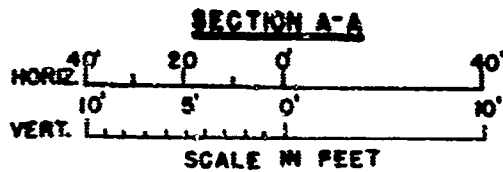
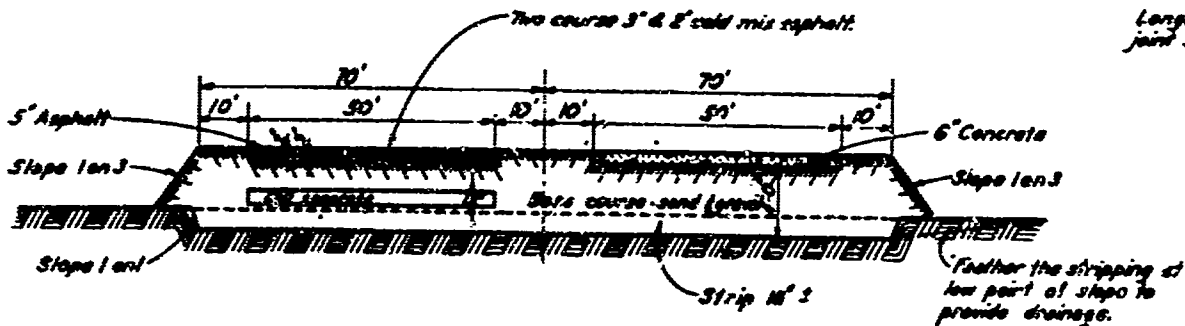

Longitudinal construction joint see section



A

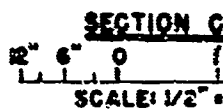
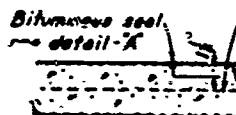
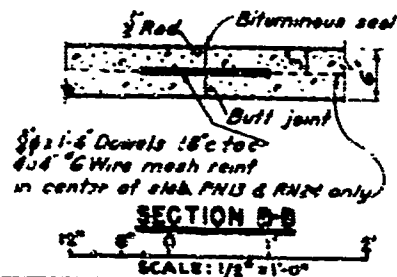

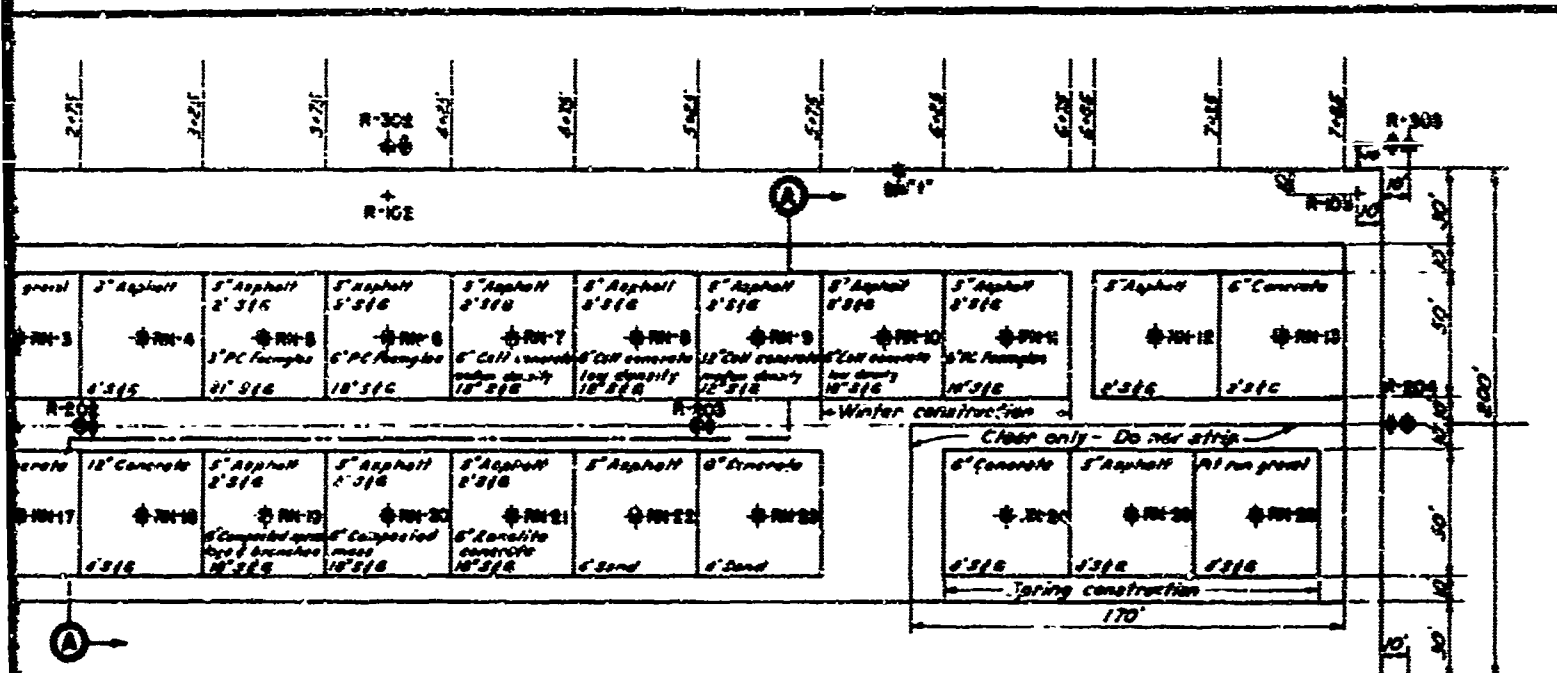

LEGEND

- ⊕ Vertical movement observation point.
- ⊕ 30' Core boring (Ground temperatures observed to 30' depth below top of fill.)
- ⊕ 10' Churn drill boring (Ground water well)
- ⊕ 15' Churn drill boring (Ground temperatures observed to 15' depth below top of fill except to 25' depth for holes RN-1 and RN-2, and to 23' depth for hole RN-2.)
- ⊕ Bench mark
- ⊕ Frost observation point.

Note:
 Thermocouples in ground temperature holes RN-1, RN-2 and RN-14 are located at the pavement surface and at 6", 1'-6", 2'-6", 3'-6", 4'-6", 5'-6", 7'-6", 9'-6", 11'-6", 12'-6", 14'-6", 15'-6", 20' and 25' below the surface except that in RN-2 the lowest thermocouple is at 23' instead of 25'.
 Thermocouples in ground temperature holes RN-3 and RN-26 are located at the gravel surface and at 6", 1'-6", 2'-6", 4'-6", 10' and 15' below the surface.
 Thermocouples in ground temperature hole RN-18 are located at the pavement surface and at 1', 1'-6", 2'-6", 3'-6", 5'-6", 7'-6", and 15' below the surface.
 Thermocouples in ground temperature holes R-201, R-202, R-203 and R-204 are located at the gravel surface and at 6", 1'-6", 2'-6", 4'-6", 10', and 15' below the surface.
 Thermocouples in all other ground temperature holes in Area 2 are located at the pavement surface and at 6", 1'-6", 2'-6", 3'-6", 4'-6", 6'-6", 10'-6", and 15'-6" below the surface.
 Vertical movement observation points for unpaved sections are located the same as those shown in typical paving section except that the center point is not off-set.

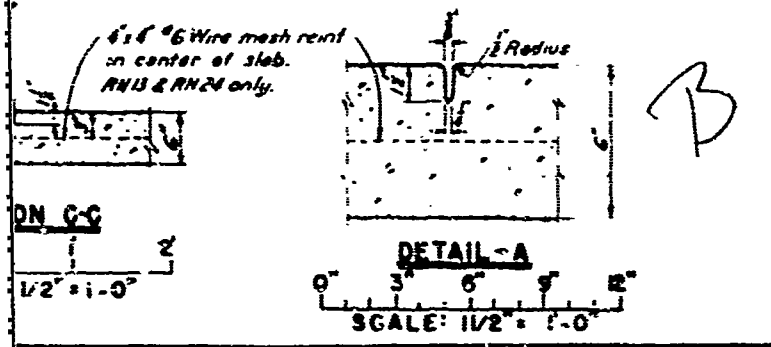
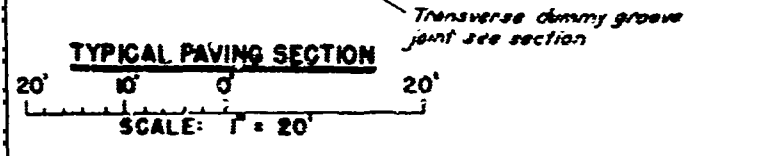
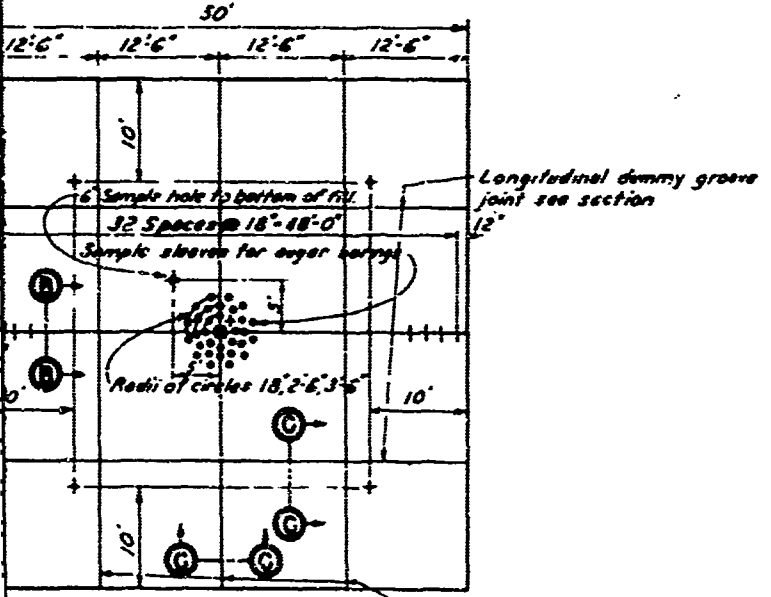

**PERMAFROST INVESTIGATION
 FIELD RESEARCH
 FAIRBANKS, ALASKA
 AREA NO. 2
 RUNWAY FOUNDATION STUDIES**

SCALE: AS SHOWN
 CORPS OF ENGINEERS ST. PAUL, MINN. MAY 1960
 DRAWN BY CWS TRACED BY: B.S.J. CHECKED BY:

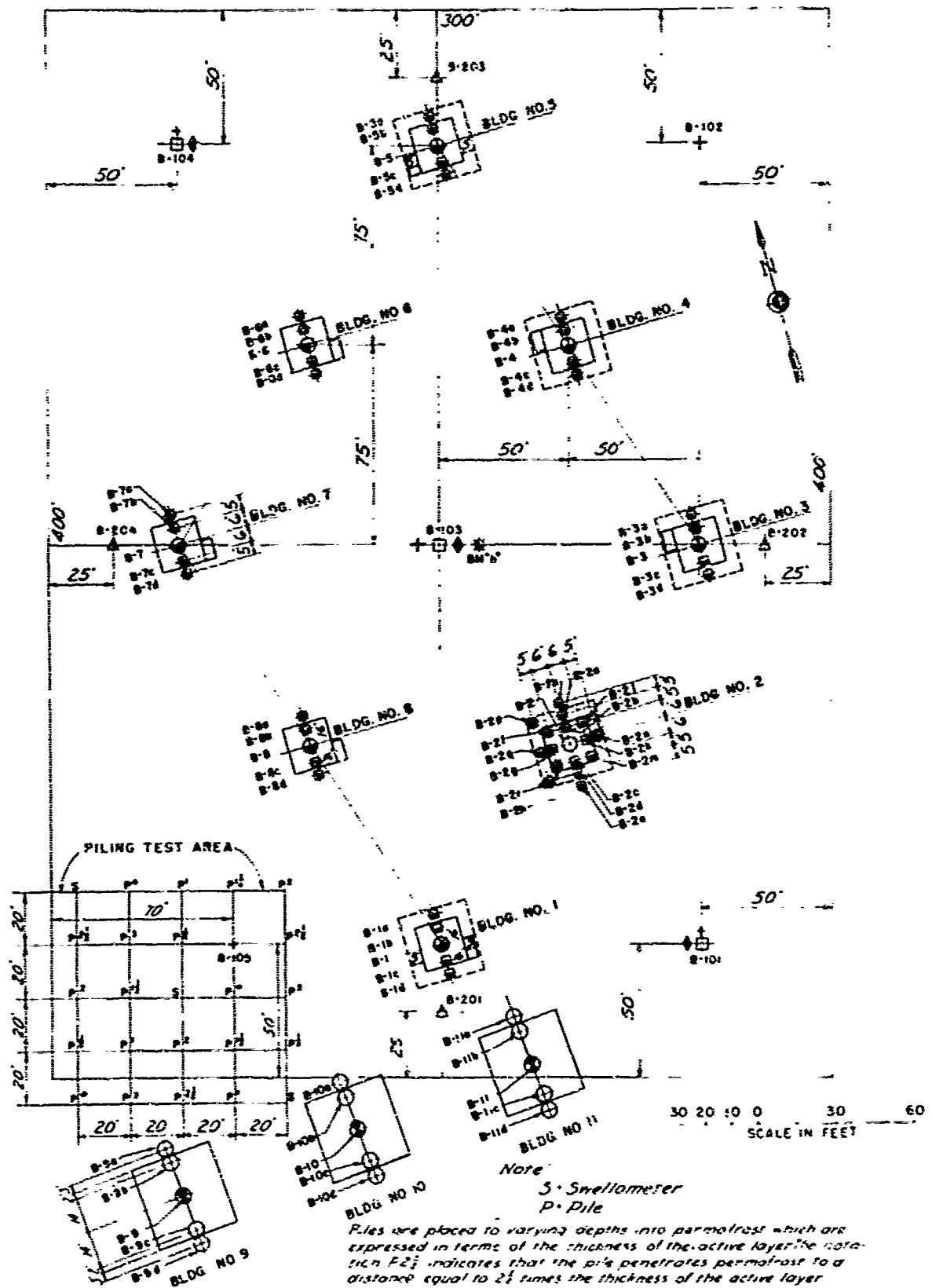

- LEGEND**
- ⊙ CORE BORING 40' DEEP
 - ⊕ CORE BORING 30' DEEP
 - ⊗ CORE BORING 20' DEEP
 - ⊠ CHURN DRILL HOLE 30' DEEP
 - ⊡ CHURN DRILL HOLE 20' DEEP
 - ⊕ VERTICAL MOVEMENT OBSERVATION POINT
 - ⊕ BENCH MARK
 - ⊠ CHURN DRILL HOLE, 10' DEEP GROUND WATER WELL
 - ⊕ FROST OBSERVATION POINT
- } GROUND TEMPERATURE MOLES

**PERMAFROST INVESTIGATION
FIELD RESEARCH
FAIRBANKS, ALASKA
AREA NO. 3
PLAN**

CORPUS OF ENGINEERS ST. PAUL, MINN. MAY '950
DRAWN BY O.P.A. CHECKED BY O.P.A.

MECHANICAL ANALYSIS

U. S. Standard Sieve Size

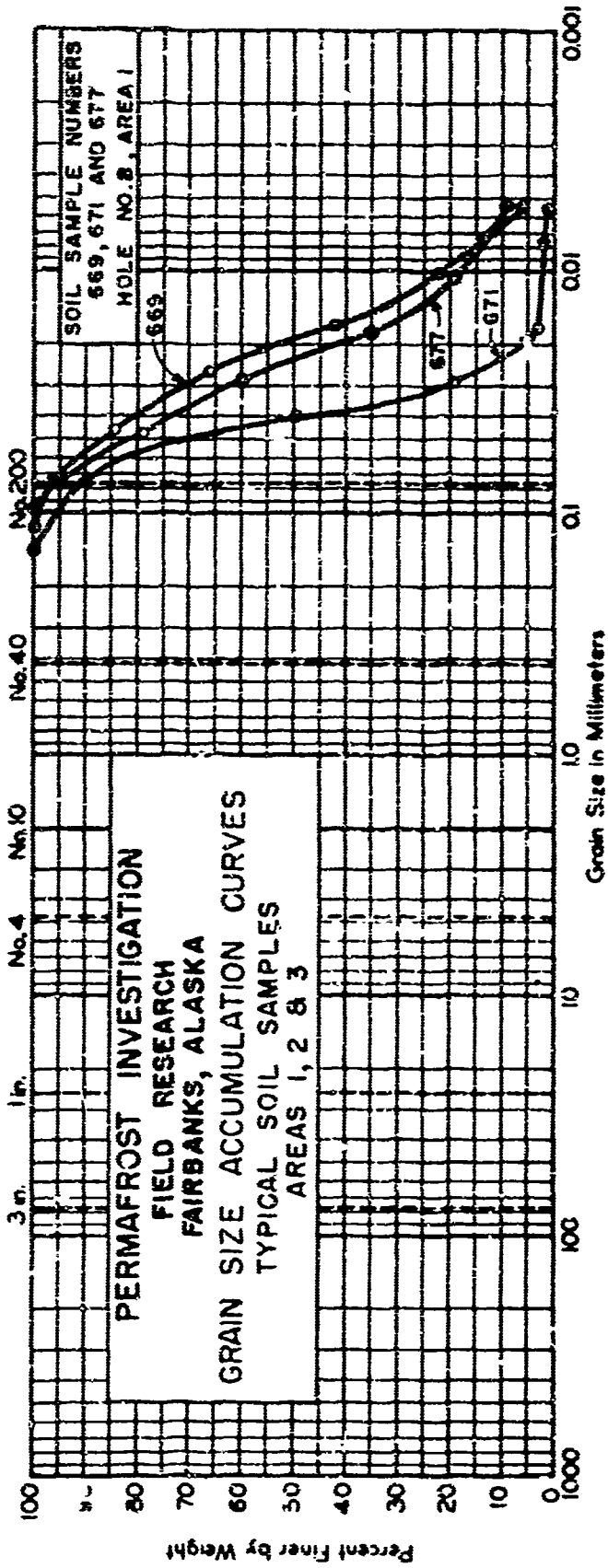

COBBLES	GRAVEL			SAND		SILT or CLAY
	Coarse	Medium	Fine	Coarse	Fine	

Number	LL	PL	PI	Classification	Remarks
669	74	-	-	Silt MH	Nonplastic
671	28	-	-	Sandy Silt MH	"
677	35	-	-	" "	"

SOILS LABORATORY
PERMAFROST
LADD, AFB, ALASKA

PROJECT Field Research
AREA No. 1
LOCATION Sec. B HOLE NO. Temp. "B"
PLOTTED BY _____ CHECKED BY _____

305
7 NOV 49

MAY 1950

HOLE NO. A

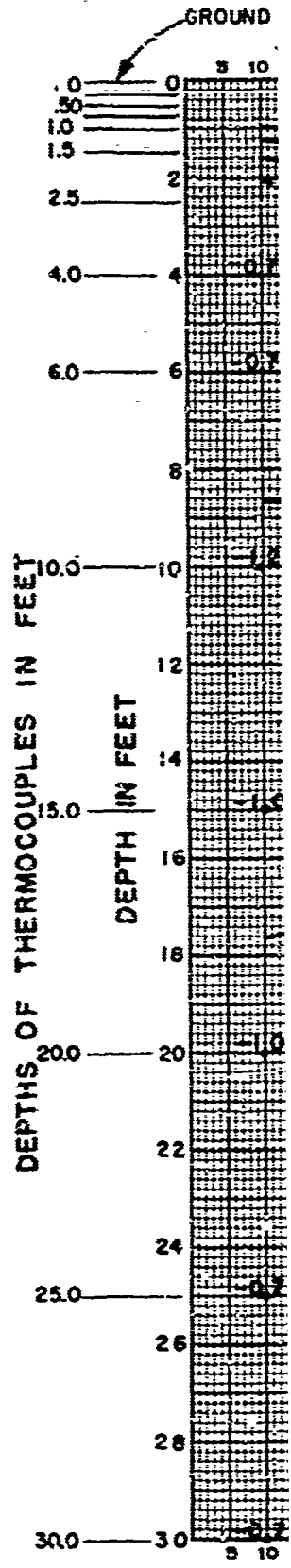
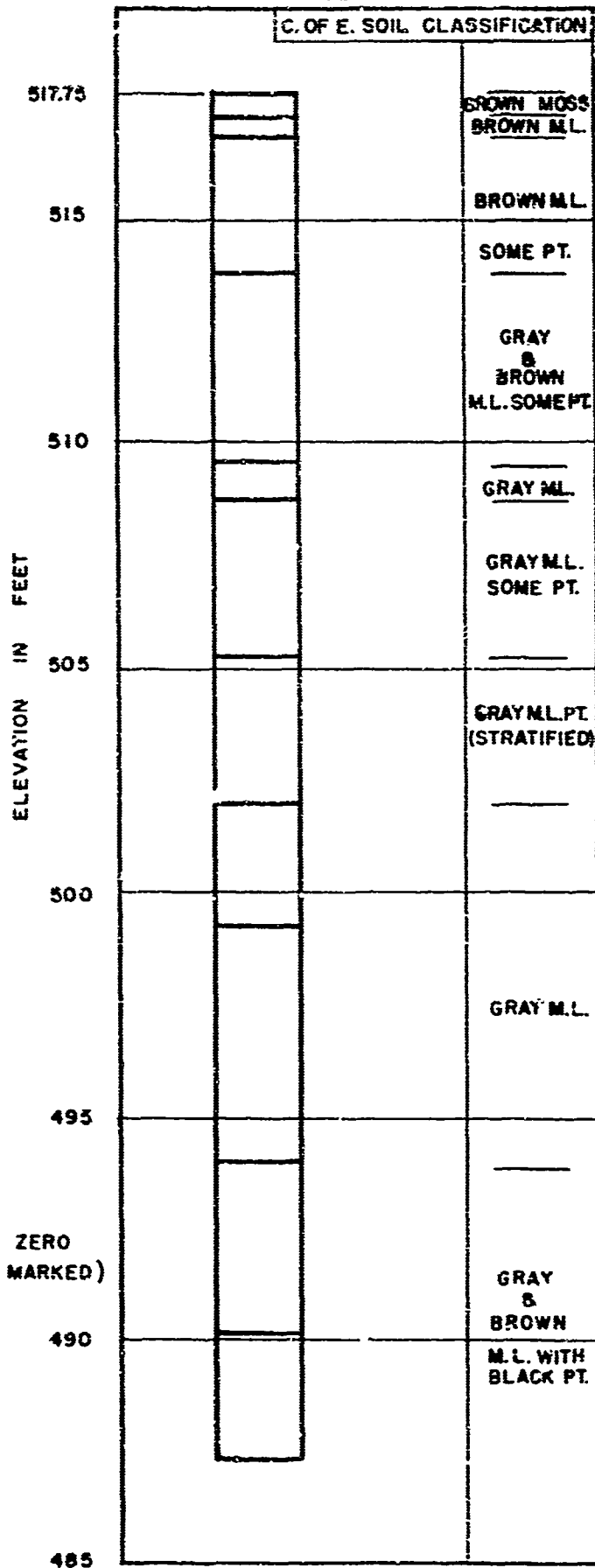

LEGEND

- ZERO ISOTHERM
- ISOTHERMS OTHER THAN ZERO
(ABOVE OR BELOW AS MARKED)

A

GROUND SURFACE EL. 51775

1946

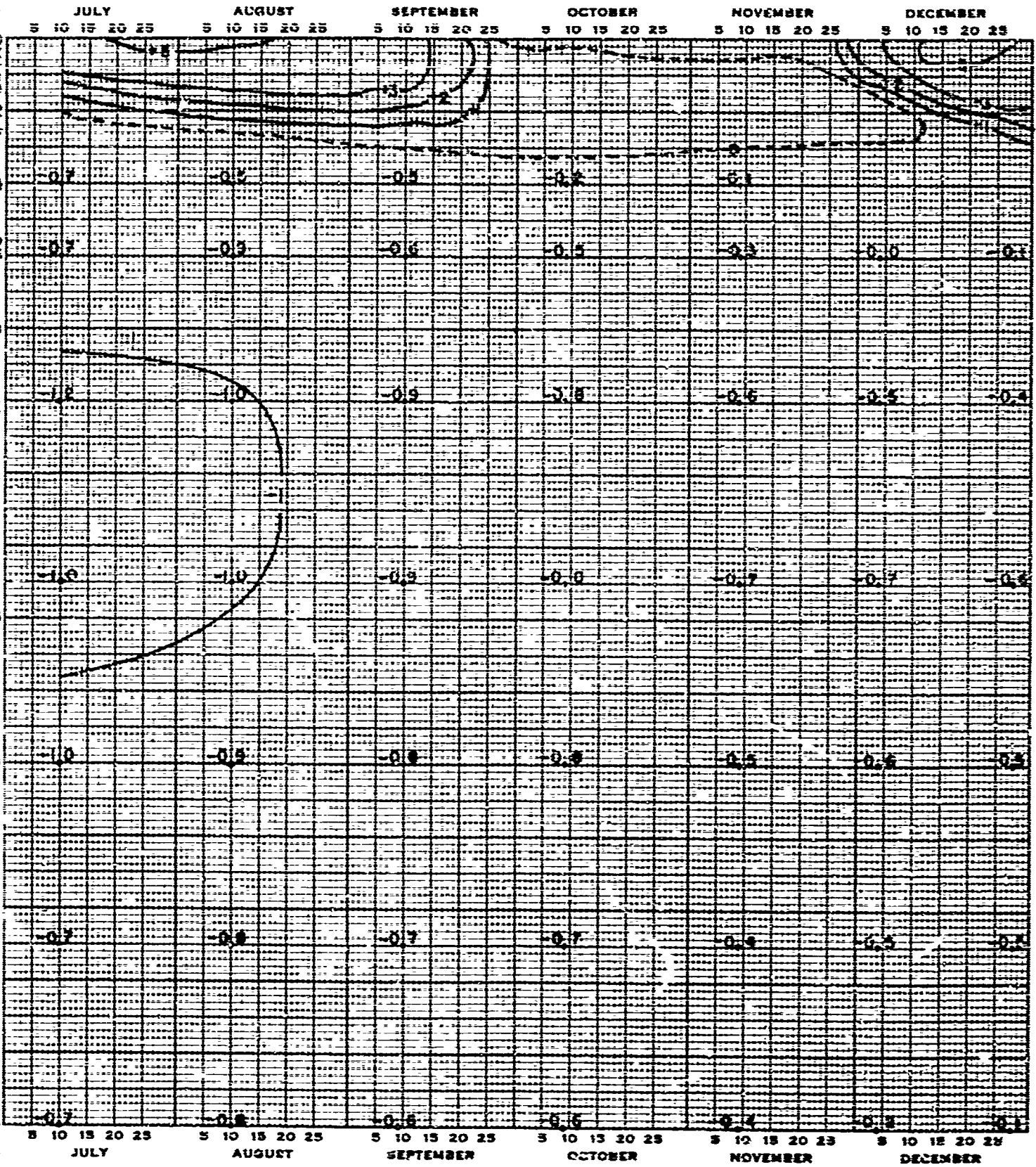

GENERAL NOTES:

ISOTHERMS SHOWN IN DEGREES CENTIGRADE.
 LOCATION OF GROUND TEMPERATURE HOLE
 SHOWN ON PLATE III 5

B

PERMAFROST INVESTIGATION
 FIELD RESEARCH - FAIRBANKS, ALASKA
 AREA NO. 1, HOLE NO. A
 GROUND ISOTHERMS
 AND SURFACE ELEVATIONS
 1946
 U.S. ENGR. OFFICE ST. PAUL, MINN. MAY 1950

1946

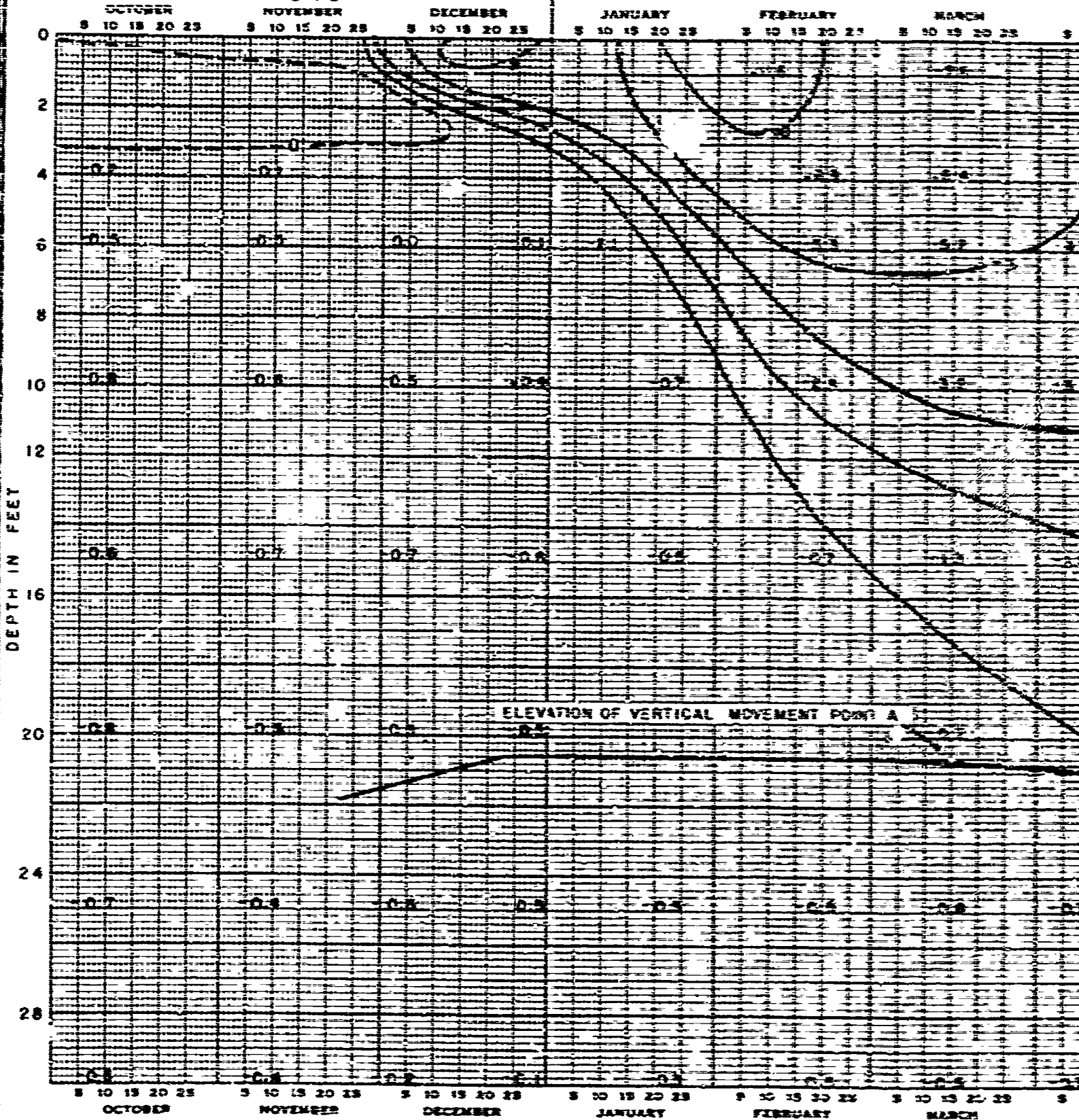

LEGEND

- ZERO ISOTHERM
- ISOTHERMS OTHER THAN ZERO
(ABOVE OR BELOW AS MARKED)

H

1947

JANUARY 10 15 20 25 FEBRUARY 5 10 15 20 25 MARCH 5 10 15 20 25 APRIL 5 10 15 20 25 MAY 5 10 15 20 25 JUNE 5 10 15 20 25 JULY 5 10 15 20 25

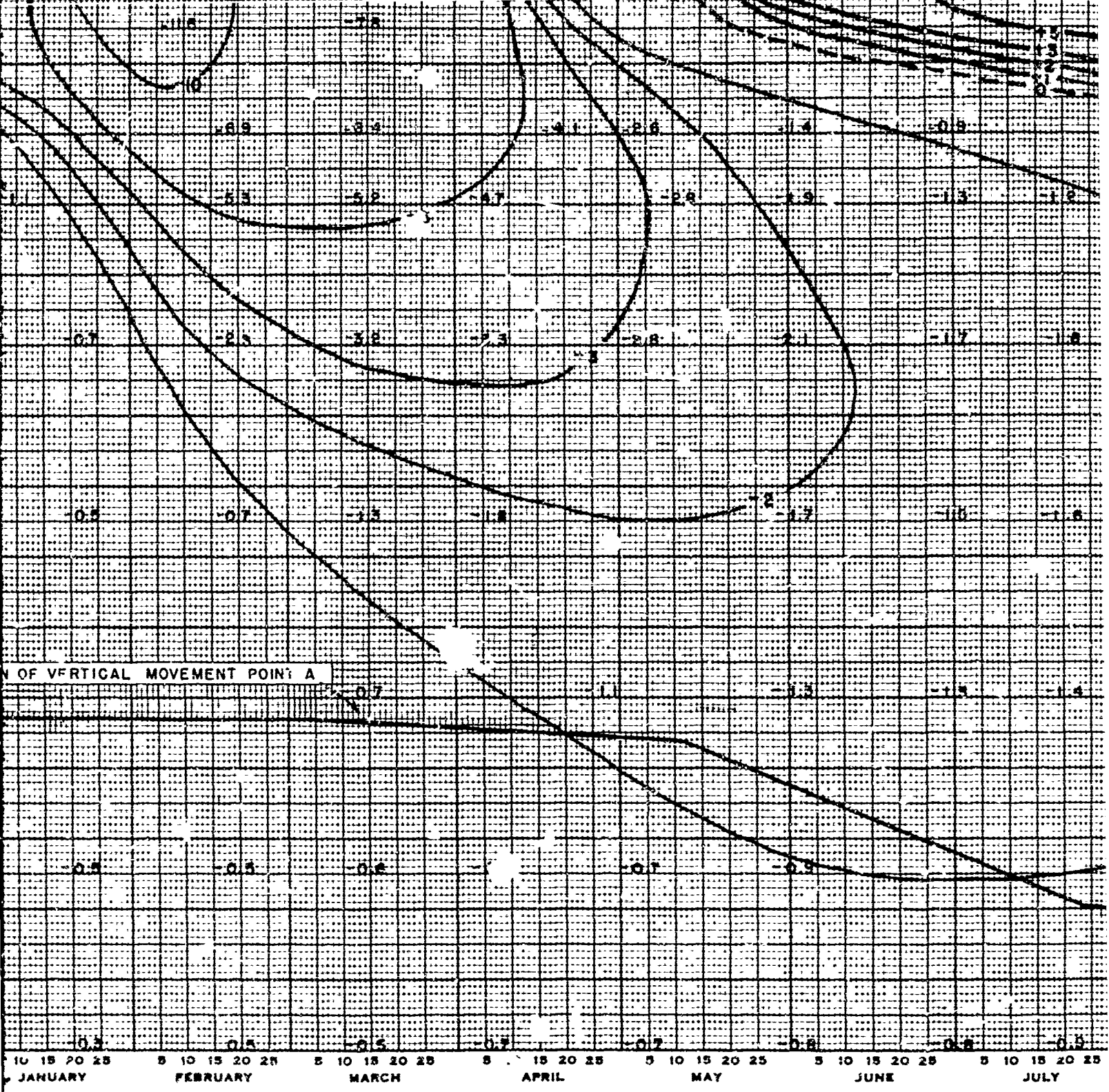

LEGEND

- ZERO ISOTHERM
- ISOTHERMS OTHER THAN ZERO
(ABOVE OR BELOW AS MARKED)

GENERAL NOTES:

ISOTHERMS SHOWN IN DEGREES CENTIGRADE.
SECTION A IS ENTIRELY UNDISTURBED AND IS COVERED WITH TREES, BRUSH, AND MOSS.

B

1947

JUNE

JULY

AUGUST

SEPTEMBER

OCTOBER

20 25 5 10 15 20 25 5 10 15 20 25 5 10 15 20 25 5 10 15 20 25 5 10 15 20 25

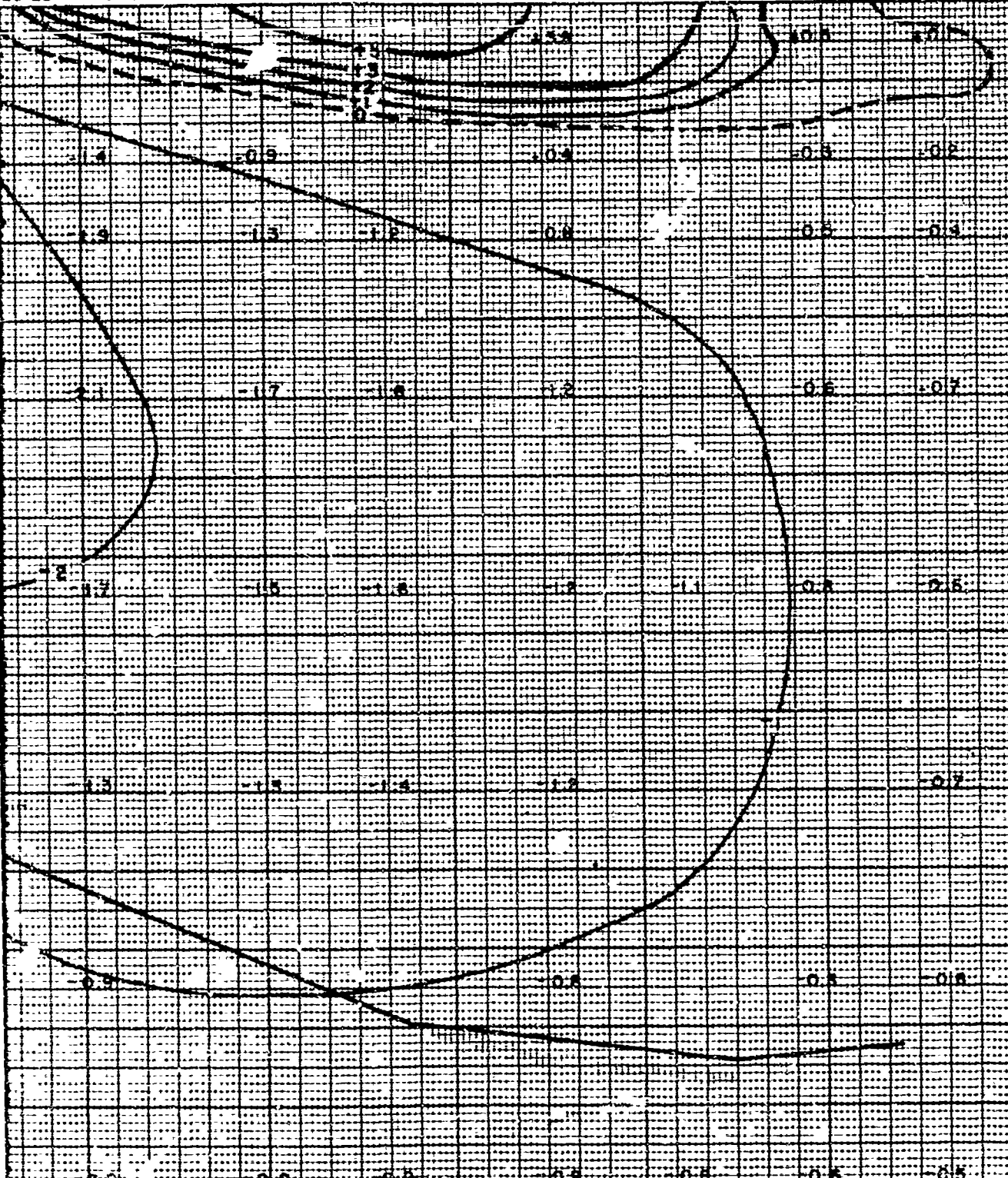

518.4
518.3
518.2
518.1
518.0

ELEVATION

20 25 5 10 15 20 25 5 10 15 20 25 5 10 15 20 25 5 10 15 20 25 5 10 15 20 25

JUNE

JULY

AUGUST

SEPTEMBER

OCTOBER

NOTES:
 RMS SHOWN IN DEGREES CENTIGRADE.
 N A IS ENTIRELY UNDISTURBED AND
 D WITH TREES, BRUSH, AND MOSS.

C

PERMAFROST INVESTIGATION
 FIELD RESEARCH-FAIRBANKS, ALASKA
 AREA NO. 1 - HOLE NO. A
 GROUND ISOTHERMS AND SURFACE ELEVATIONS
 1946-47
 CORPS OF ENGINEERS, ST. PAUL, MINN. MAY 1950

PLATE III-10

GROUND SURFACE ELEV. 518.3

1947

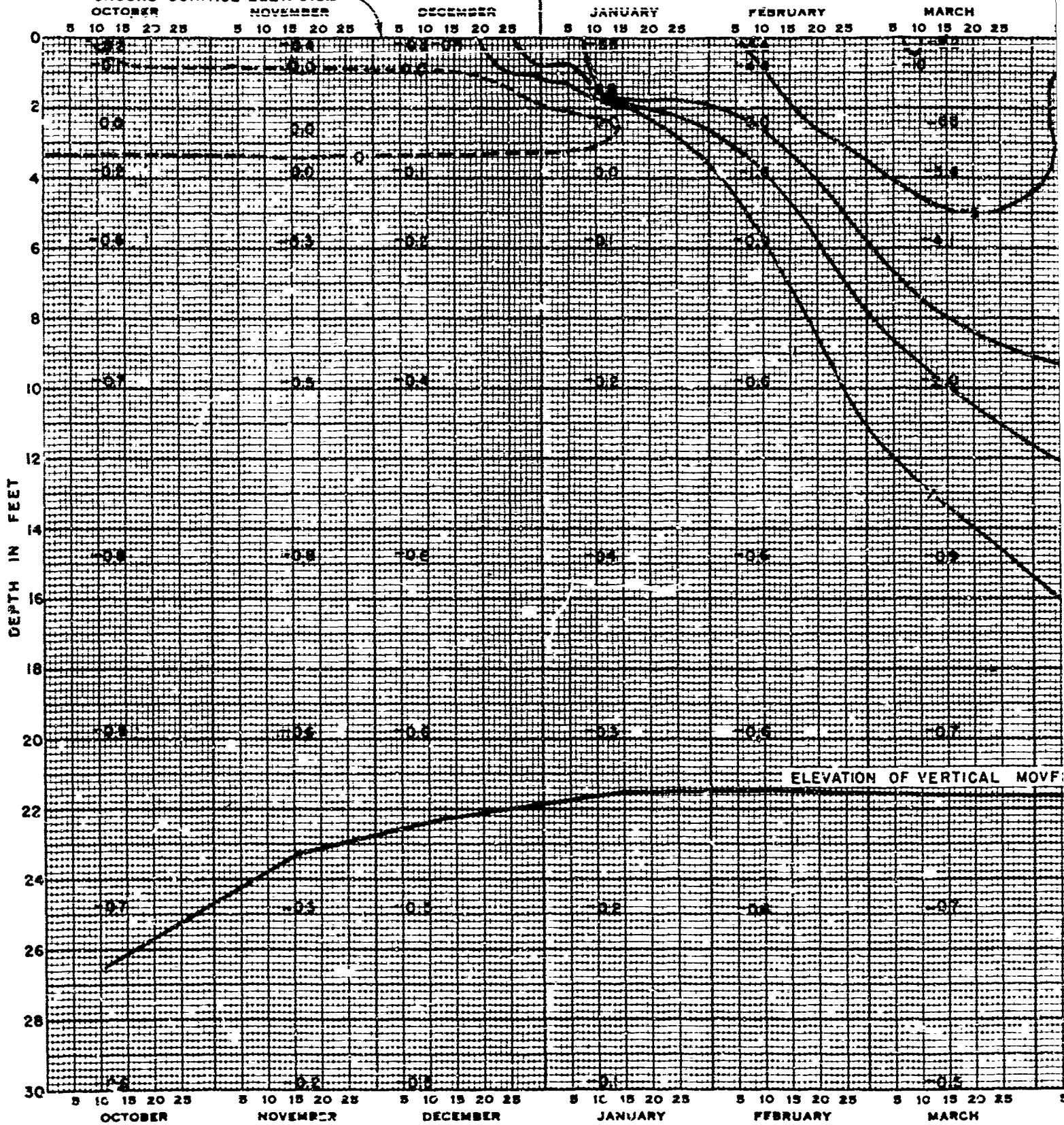

LEGEND

- ZERO ISOTHERM
- ISOTHERMS OTHER THAN ZERO (ABOVE OR BELOW AS MARKED)

11

1948

JANUARY FEBRUARY MARCH APRIL MAY JUNE
5 10 15 20 25 5 10 15 20 25 5 10 15 20 25 5 10 15 20 25 5 10 15 20 25 5 10 15 20 25

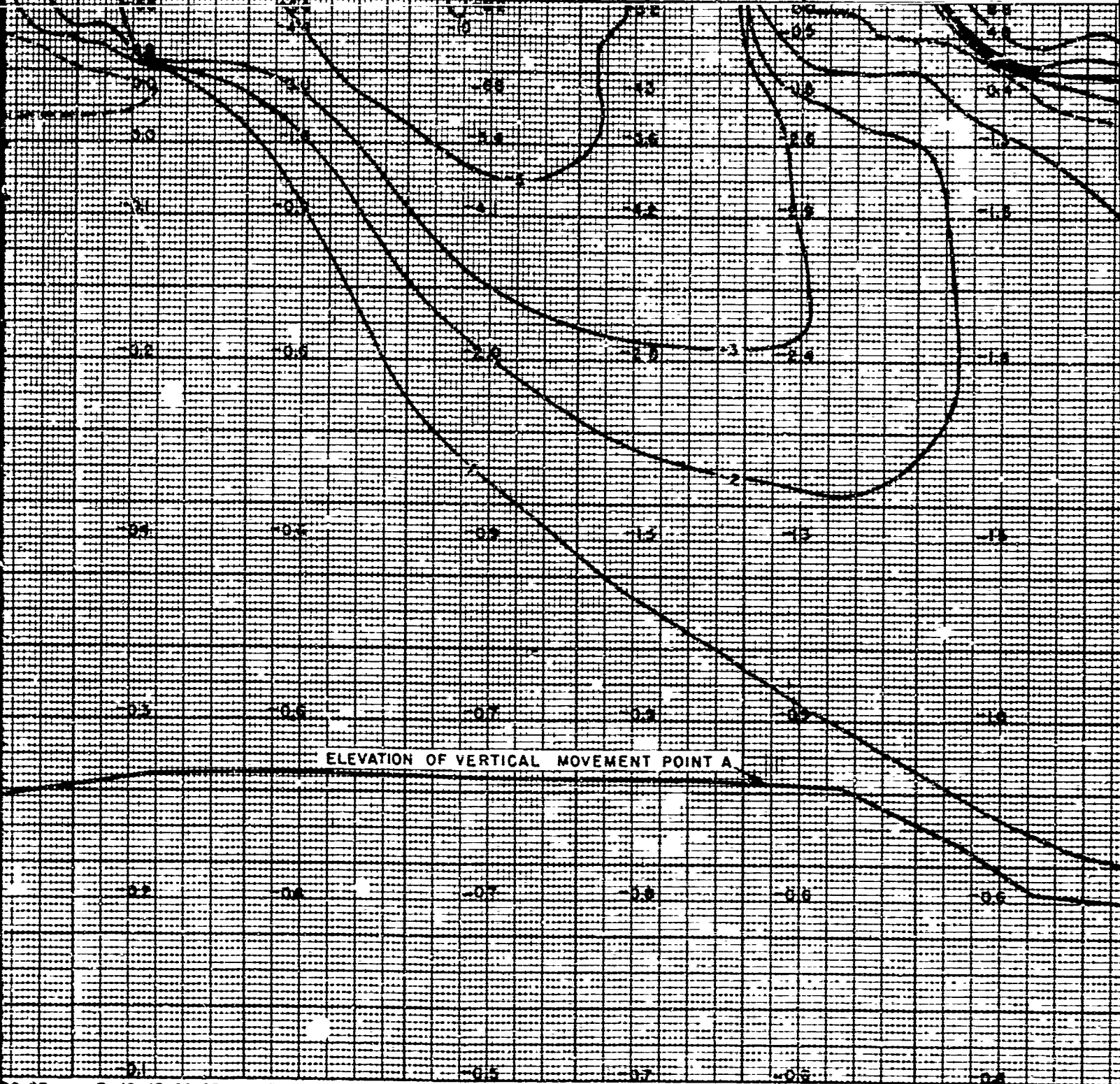

ELEVATION OF VERTICAL MOVEMENT POINT A

LEGEND

- ZERO ISOTHERM
- ISOTHERMS OTHER THAN ZERO
(.BOVE OR BELOW AS MARKED)

GENERAL NOTES:

ISOTHERMS SHOWN IN DEGREES CENT
SECTION A IS ENTIRELY UNDISTURBE
IS COVERED WITH TREES, BRUSH, AND MO

3

HOLE NO. B

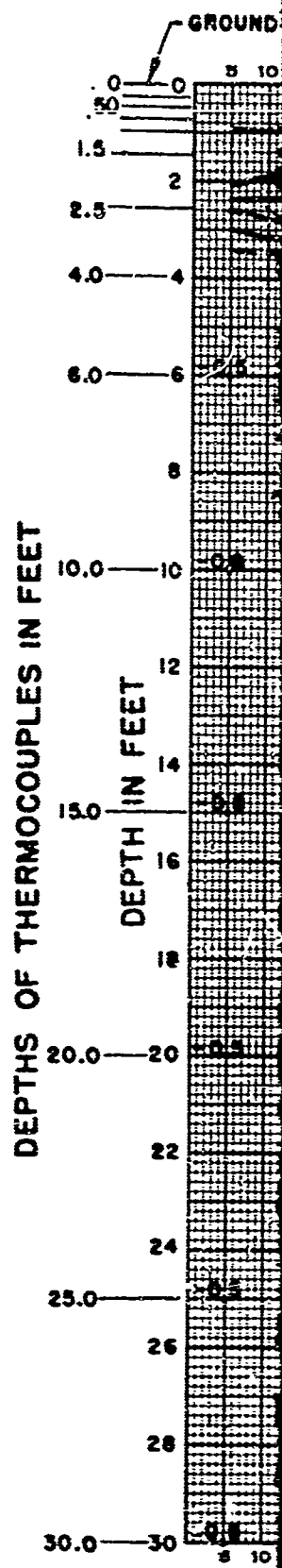
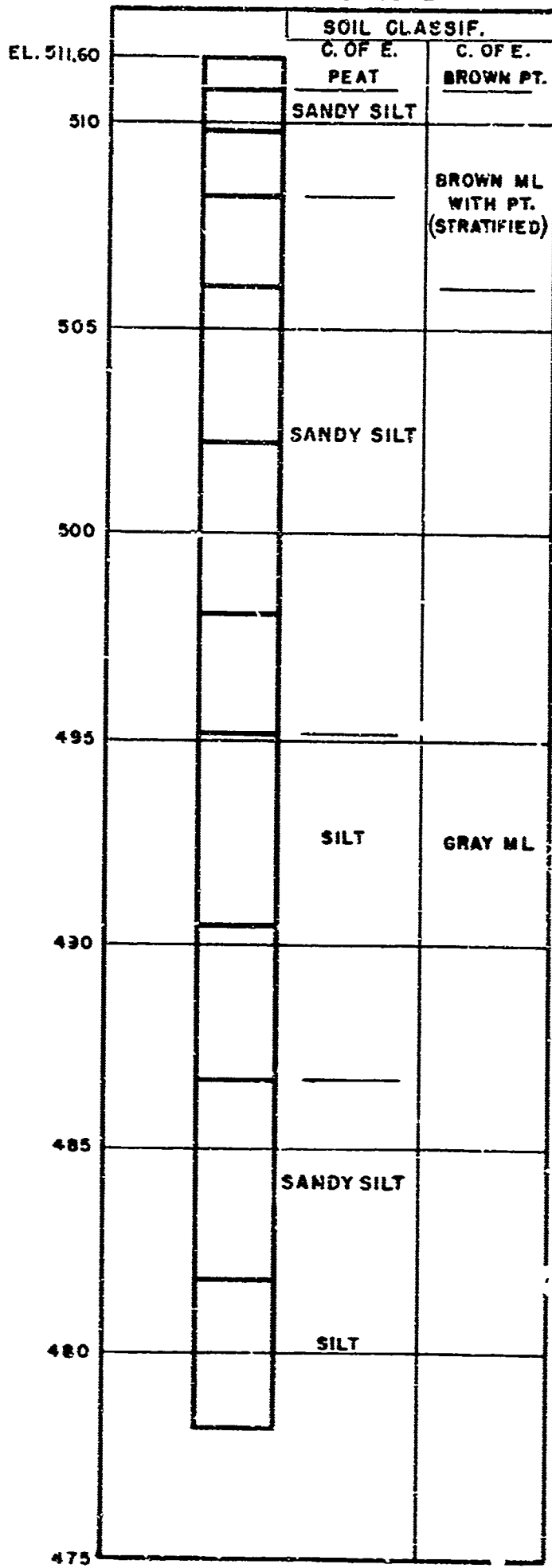

LEGEND

- ZERO ISOTHERM
- ISOTHERMS OTHER THAN ZERO (ABOVE OR BELOW AS MARKED)

A

GROUND SURFACE EL. 51.60

1946

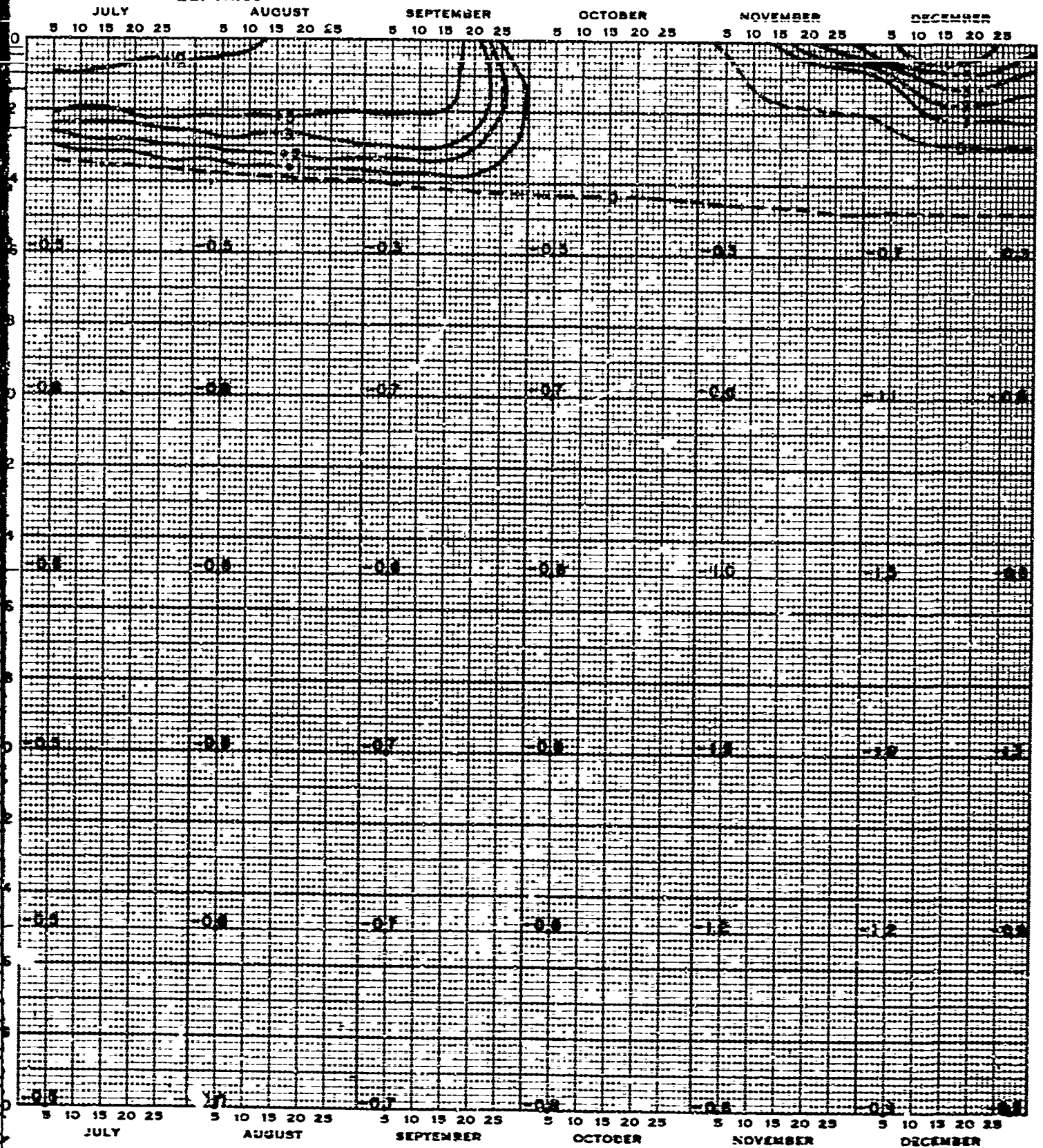

GENERAL NOTES:

ISOTHERMS SHOWN IN DEGREES CENTIGRADE.
 LOCATION OF GROUND TEMPERATURE HOLE
 SHOWN ON PLATE III - 5

PERMAFROST INVESTIGATION
 FIELD RESEARCH - FAIRBANKS, ALASKA
 AREA NO. 1 - HOLE B
 GROUND ISOTHERMS AND SURFACE ELEVATIONS
 1946

U.S. ENGR. OFFICE ST. PAUL, MINN. MAY 1950

PLATE III-12

1946

OCTOBER

NOVEMBER

DECEMBER

JANUARY

FEBRUARY

MARCH

DEPTH IN FEET

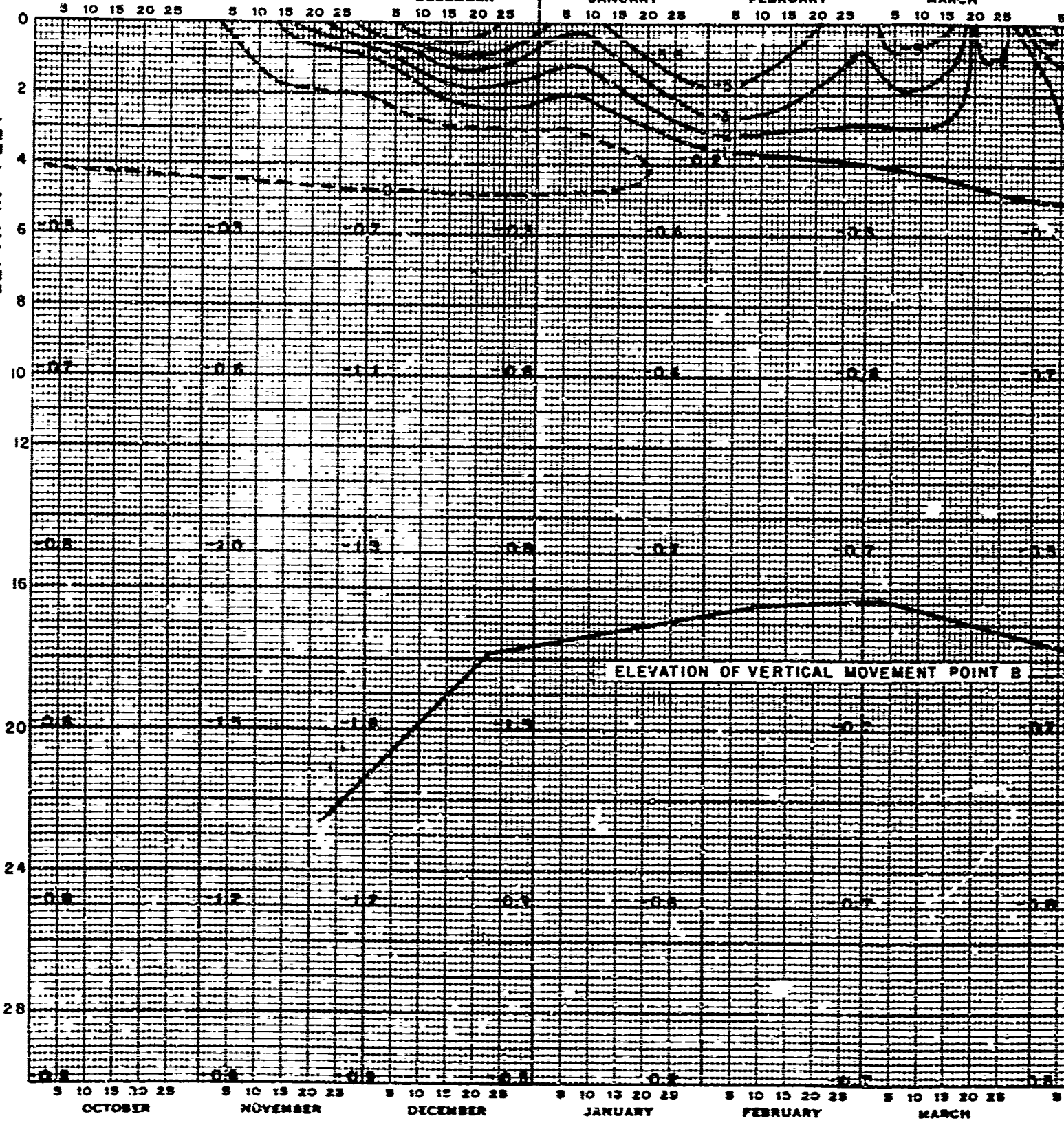

LEGEND

- ZERO ISOTHERM
- ISOTHERMS OTHER THAN ZERO
(ABOVE OR BELOW AS MARKED)

4

1947

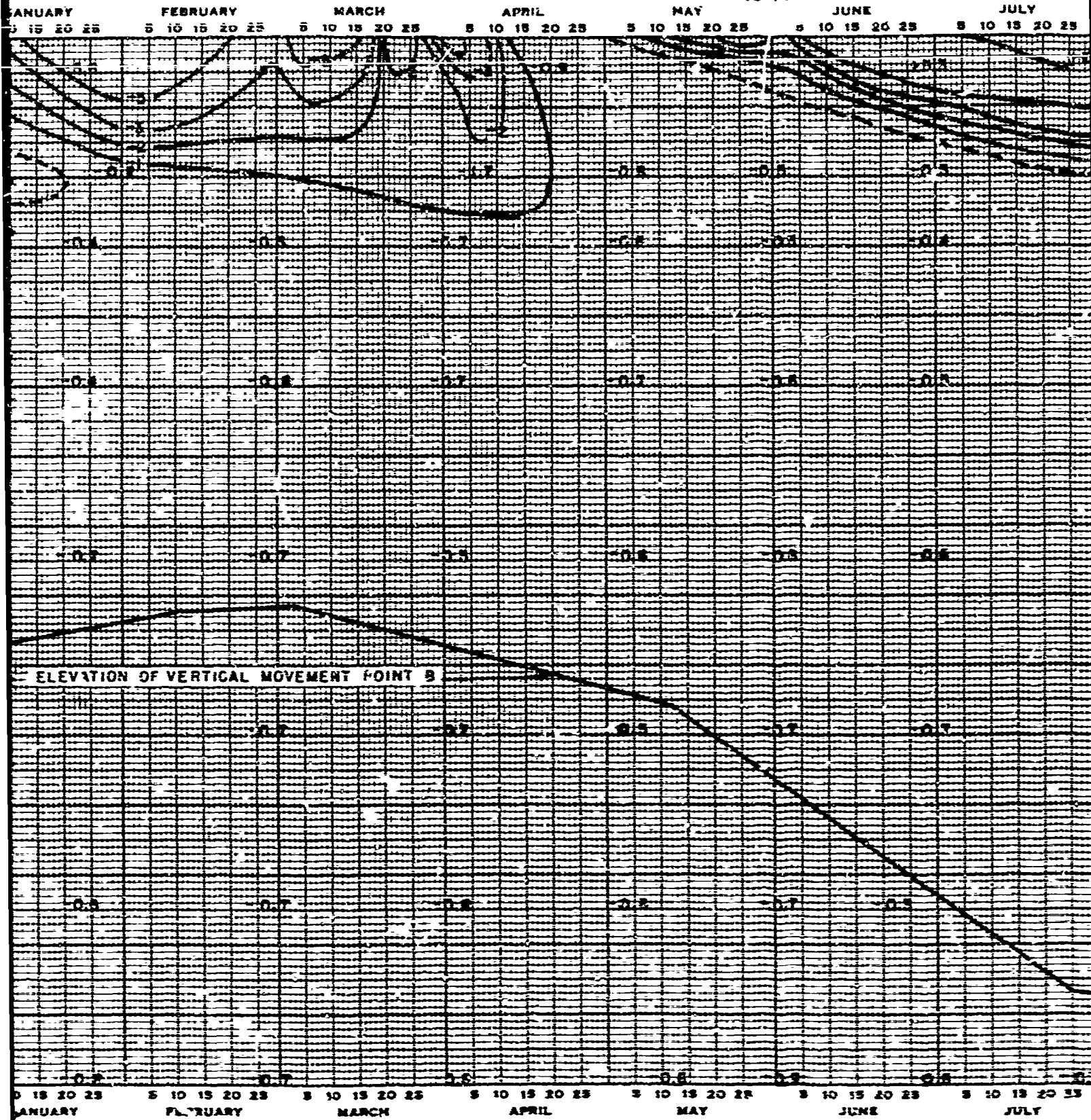

LEGEND

- ZERO ISOTHERM
- ISOTHERMS OTHER THAN ZERO
(ABOVE OR BELOW AS MARKED)

GENERAL NOTES:

ISOTHERMS SHOWN IN DEGREES CENTIGRADE.
SECTION B HAS BEEN CLEARED OF TREES AND
BRUSH. MOSS COVER NOT REMOVED.

13

1947

JUNE

JULY

AUGUST

SEPTEMBER

OCTOBER

20 25 5 10 15 20 25 5 10 15 20 25 5 10 15 20 25 5 10 15 20 25 5 10 15 20 25

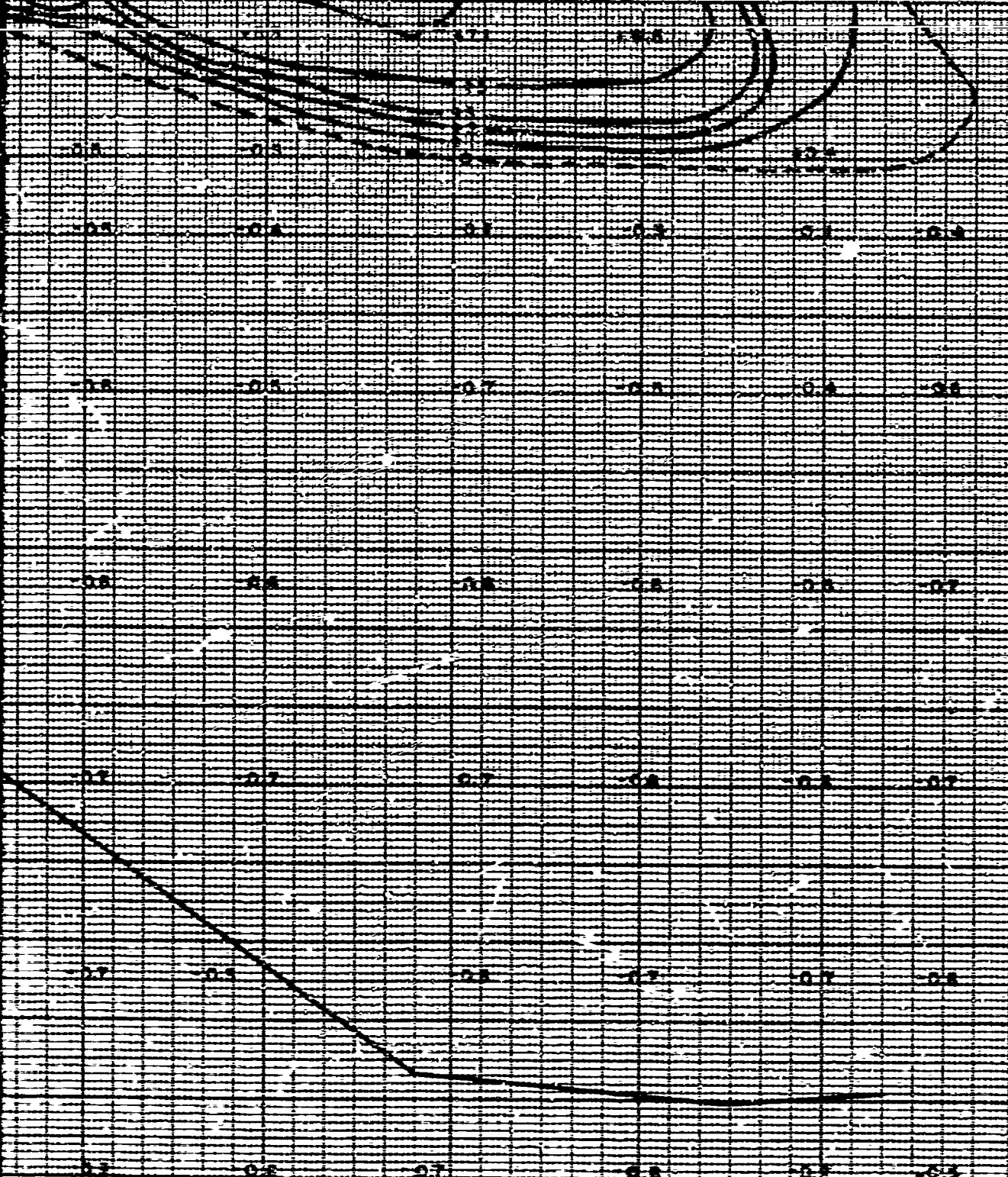

512.2
512.1
512.0
511.9
511.8
511.7
511.6
511.5

ELEVATION

20 25 5 10 15 20 25 5 10 15 20 25 5 10 15 20 25 5 10 15 20 25 5 10 15 20 25

JUNE

JULY

AUGUST

SEPTEMBER

OCTOBER

NOTES:
TEMPERATURES SHOWN IN DEGREES CENTIGRADE.
SITE HAS BEEN CLEARED OF TREES AND
MOSS COVER NOT REMOVED.

C

PERMAFROST INVESTIGATION
FIELD RESEARCH-FAIRBANKS, ALASKA
AREA NO.1 - HOLE NO. B
GROUND ISOTHERMS AND SURFACE ELEVATIONS
1946-47

CORPS OF ENGINEERS, ST. PAUL, MINN. MAY. 1950

1947

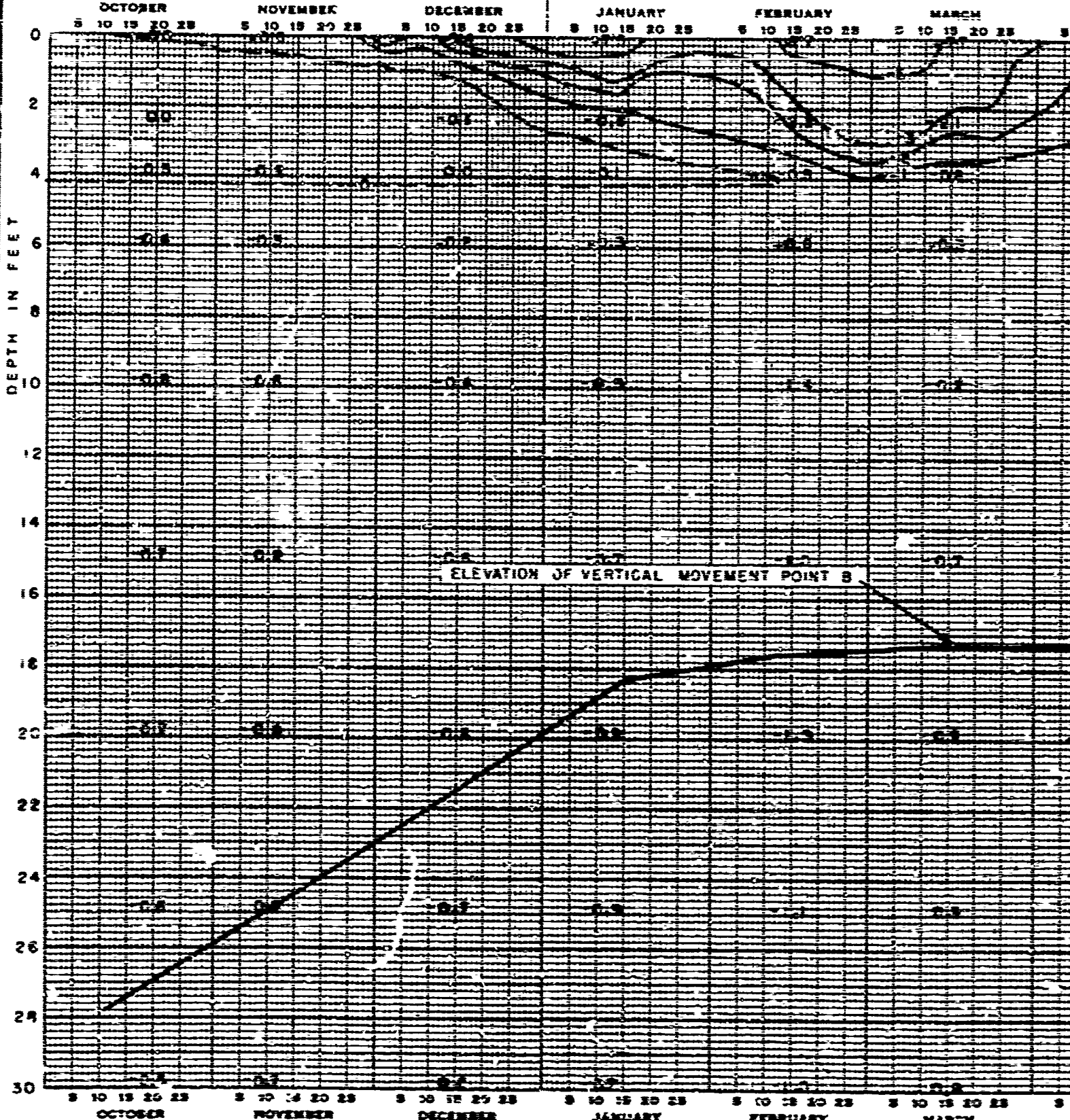

LEGEND

- ZERO ISOTHERM
- ISOTHERMS OTHER THAN ZERO (ABOVE OR BELOW AS MARKED)

1948

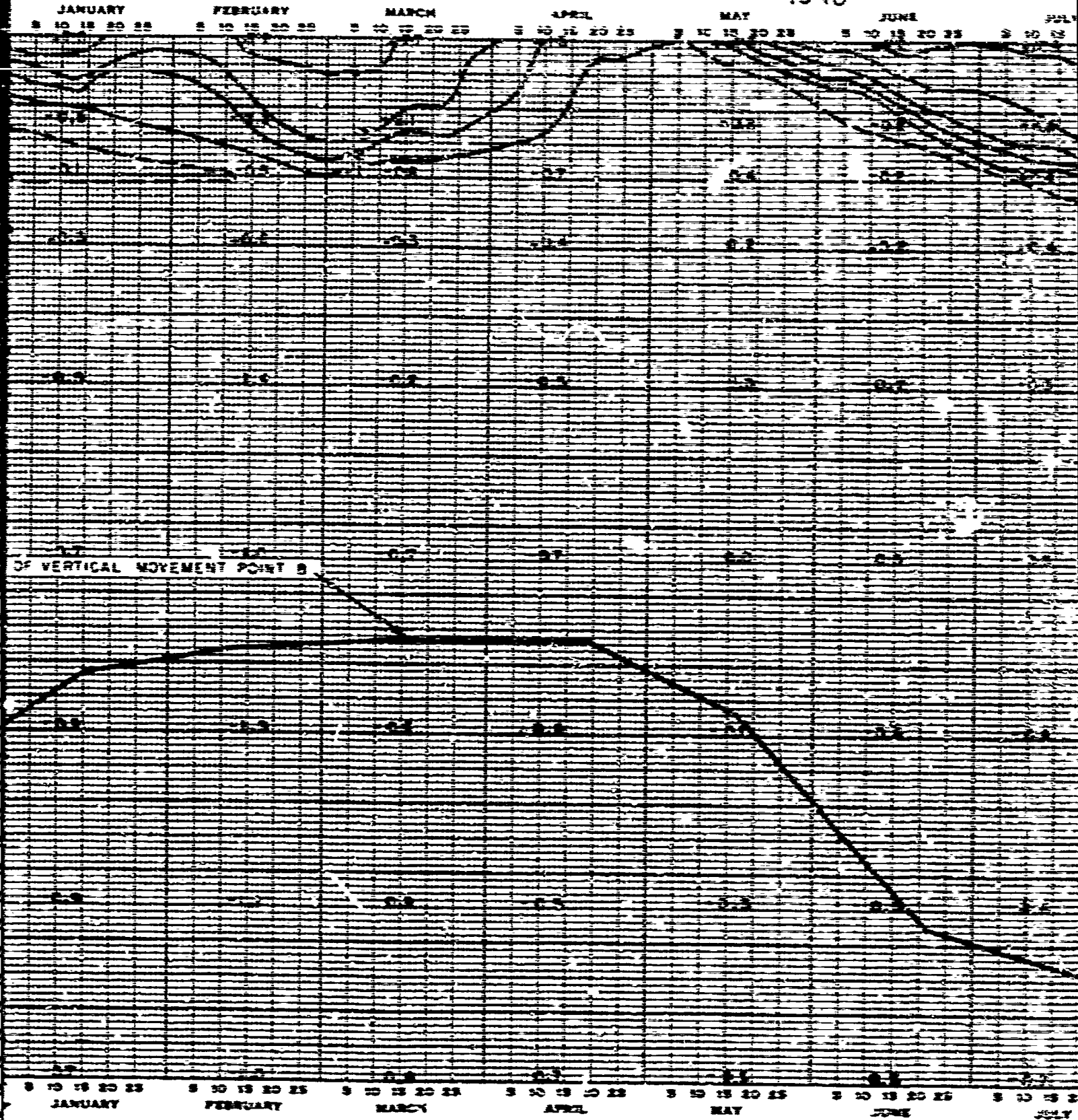

LEGEND

- ZERO ISOTHERM
- ISOTHERMS OTHER THAN ZERO
(ABOVE OR BELOW AS MARKED)

B

GENERAL NOTES:

ISOTHERMS SHOWN IN DEGREES CENTIGRADE.
 SECTION B HAS BEEN CLEARED OF TREES &
 BRUSH. MOSS COVER NOT REMOVED.

1948

JUNE

JULY

AUGUST

SEPTEMBER

OCTOBER

5 10 15 20 25 5 10 15 20 25 5 10 15 20 25 5 10 15 20 25 5 10 15 20 25

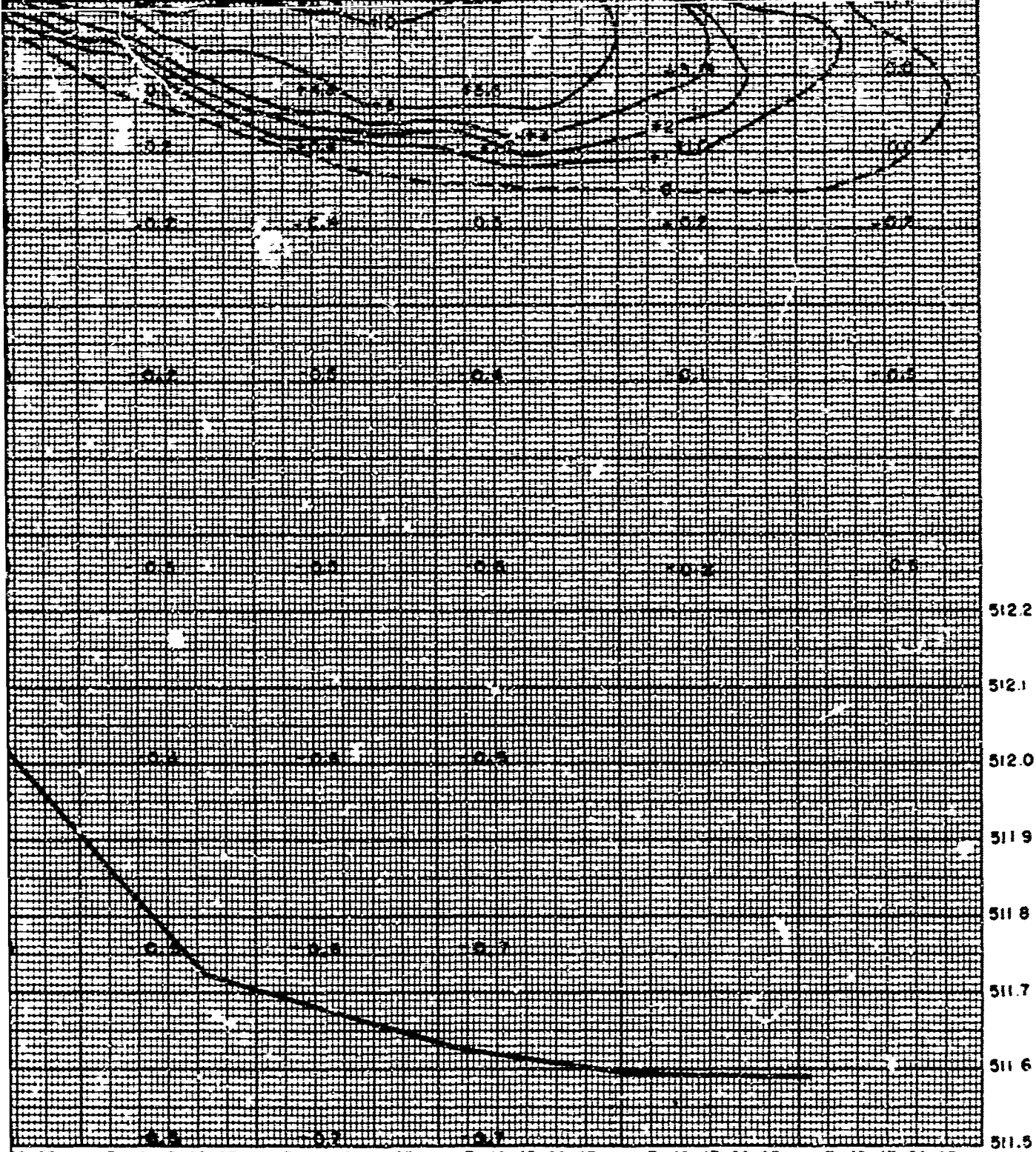

ELEVATION

512.2
512.1
512.0
511.9
511.8
511.7
511.6
511.5

5 10 15 20 25 5 10 15 20 25 5 10 15 20 25 5 10 15 20 25 5 10 15 20 25

JUNE

JULY

AUGUST

SEPTEMBER

OCTOBER

PERMAFROST INVESTIGATION

FIELD RESEARCH-FAIRBANKS, ALASKA

AREA NO. I-HOLE NO. B

GROUND ISOTHERMS AND SURFACE ELEVATIONS
1947-48

CORPS OF ENGINEERS, ST. PAUL, MINN. MAY 1950

NOTES:

TEMPERATURES SHOWN IN DEGREES CENTIGRADE.
AREA HAS BEEN CLEARED OF TREES AND
MOSS COVER NOT REMOVED.

C

HOLE NO. C

E1. 507.83

Elevation	SOIL CLASSIF.	
	G. OF E.	C. OF E.
505	PEAT	BROWN PT.
500	SANDY SILT	BROWN ML WITH PT. (STRATIFIED)
495	SILT	
490	SANDY SILT	GREY ML WITH PT. (STRATIFIED)
485	SILT	
480	SANDY SILT	GREY ML
475		

DEPTHS OF THERMOCOUPLES IN FEET

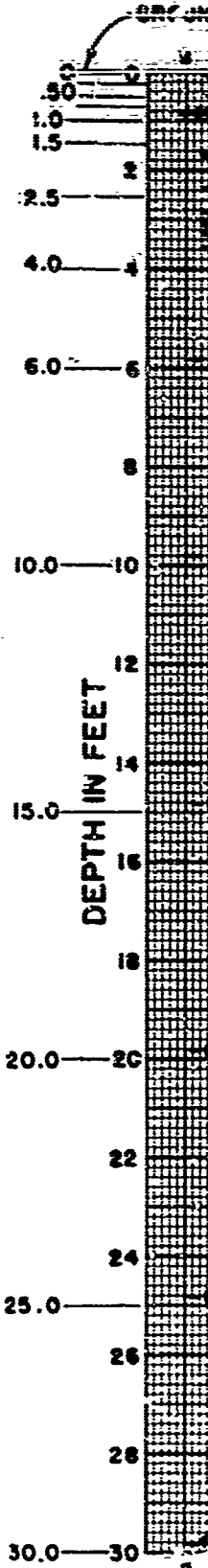

LEGEND

- ZERO ISOTHERM
- ISOTHERMS OTHER THAN ZERO (ABOVE OR BELOW AS MARKED)

A

SSIF
 C. OF E.
 1 FT.
 BROWN ML
 WITH PT.
 (STRATIFIED)
 GREY ML
 WITH PT
 (STRATIFIED)
 GREY ML

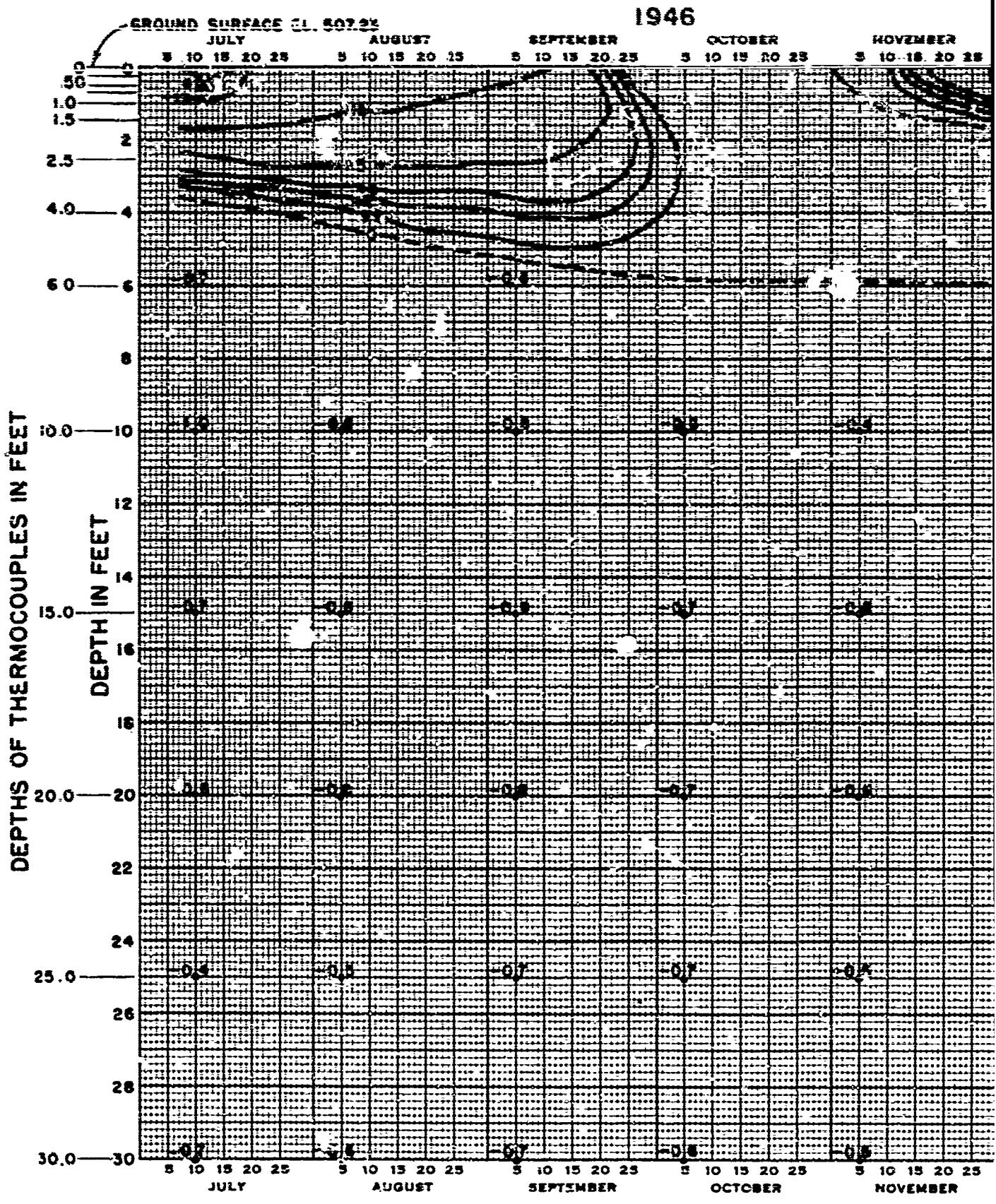

GENERAL NOTES:

ISOTHERMS SHOWN IN DEGREES CENTIGRADE.
 LOCATION OF GROUND TEMPERATURE HOLE
 SHOWN ON PLATE III - 5

PERMAFROST
 FIELD RESEARCH-
 AREA NO. 1
 GROUND ISOTHERMS AN
 19
 U.S. ENGR. OFFICE ST. PAU

B

1946

UND SURFACE EL. 507.23

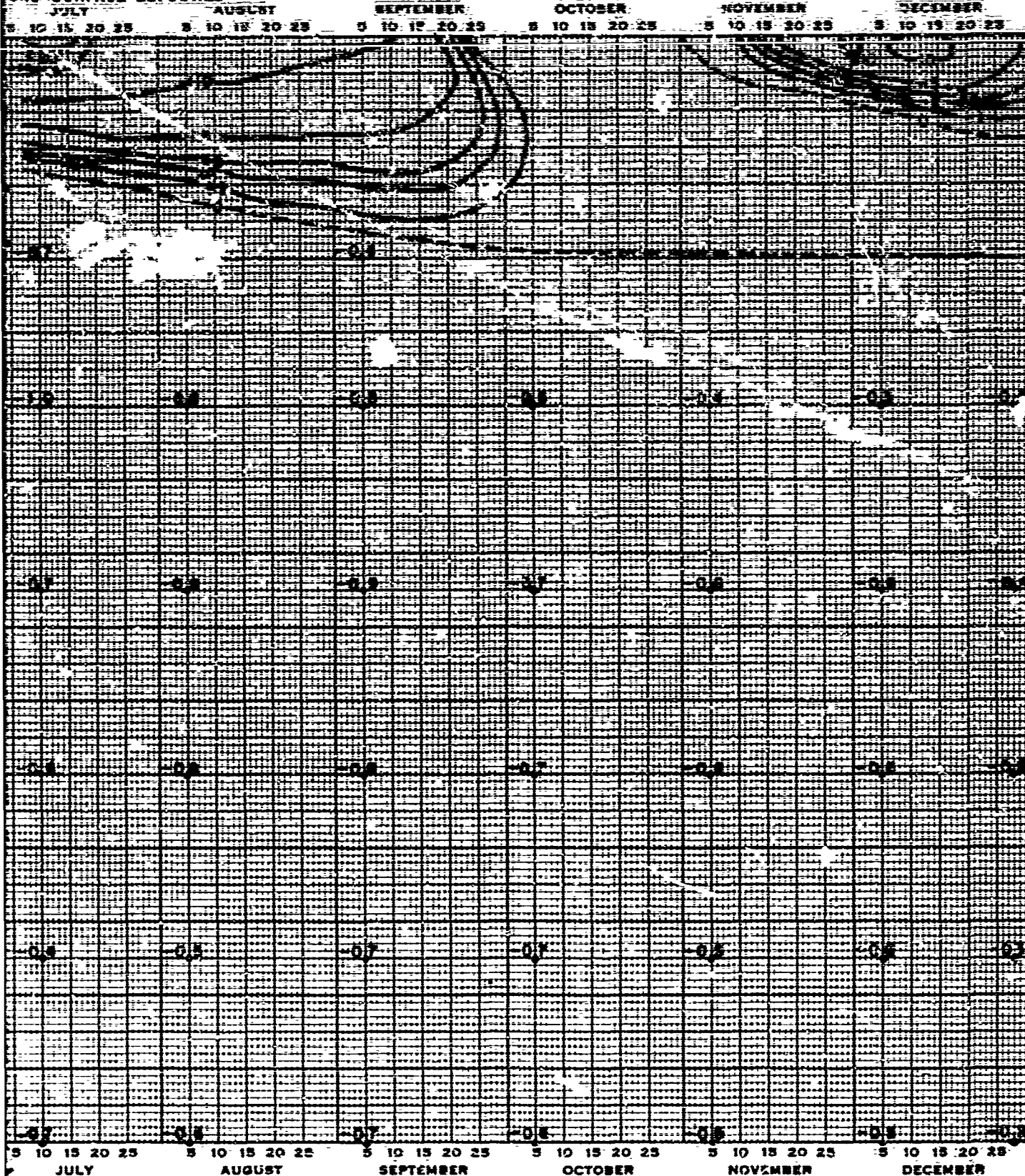

PERMAFROST INVESTIGATION
 FIELD RESEARCH- FAIRBANKS ALASKA
 AREA NO. 1-HOLE NO. C
 GROUND ISOTHERMS AND SURFACE ELEVATIONS
 1946

U.S. ENGR. OFFICE ST. PAUL, MINN. MAY 1950

GENERAL NOTES:
 ISOTHERMS SHOWN IN DEGREES CENTIGRADE.
 LOCATION OF GROUND TEMPERATURE HOLE
 SHOWN ON PLATE III-5

PLATE III-15

1946

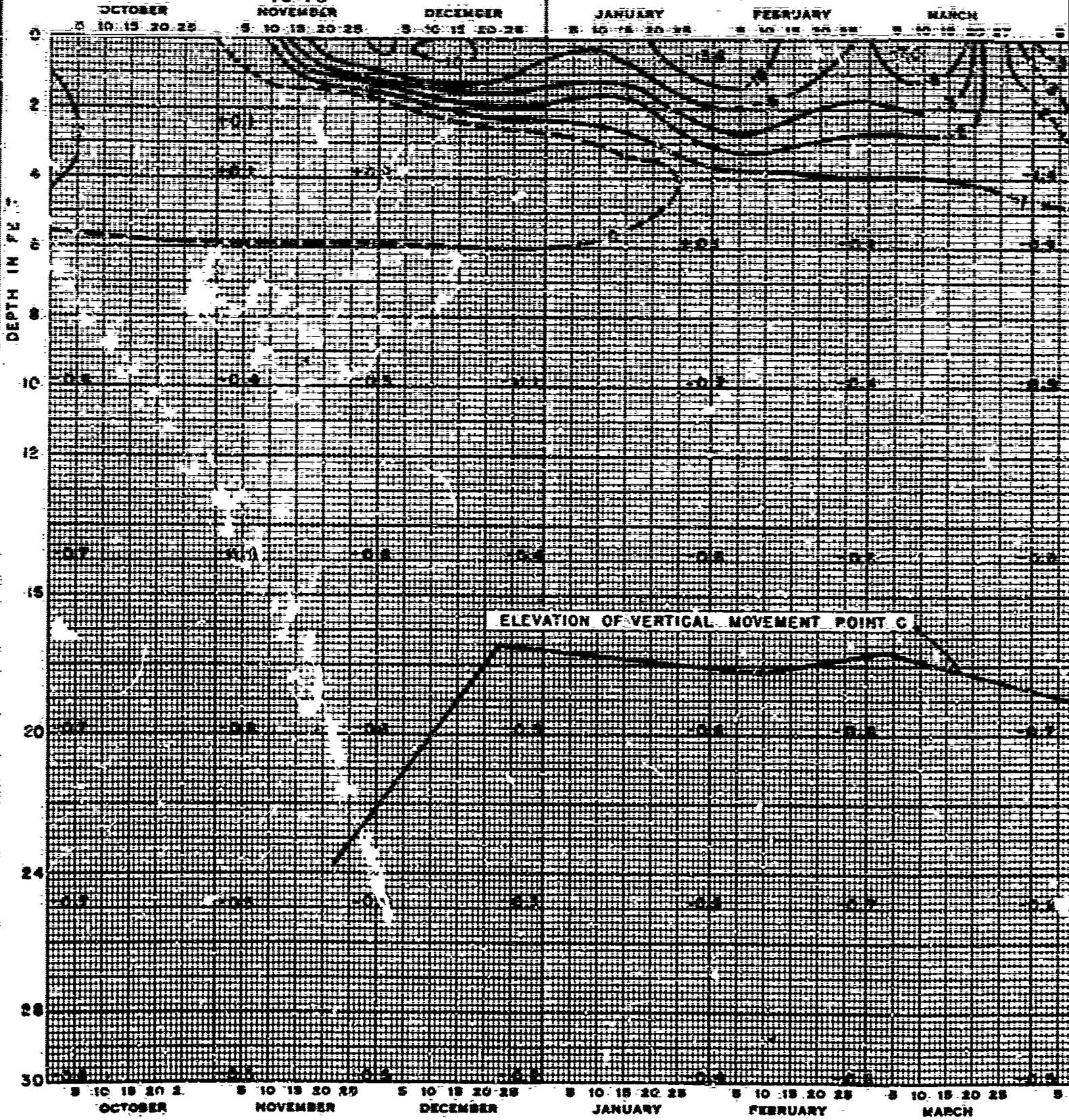

ELEVATION OF VERTICAL MOVEMENT POINT C

LEGEND

- ZERO ISOTHERM
- ISOTHERMS OTHER THAN ZERO (ABOVE OR BELOW AS MARKED)

A

1947

JUNE

JULY

AUGUST

SEPTEMBER

OCTOBER

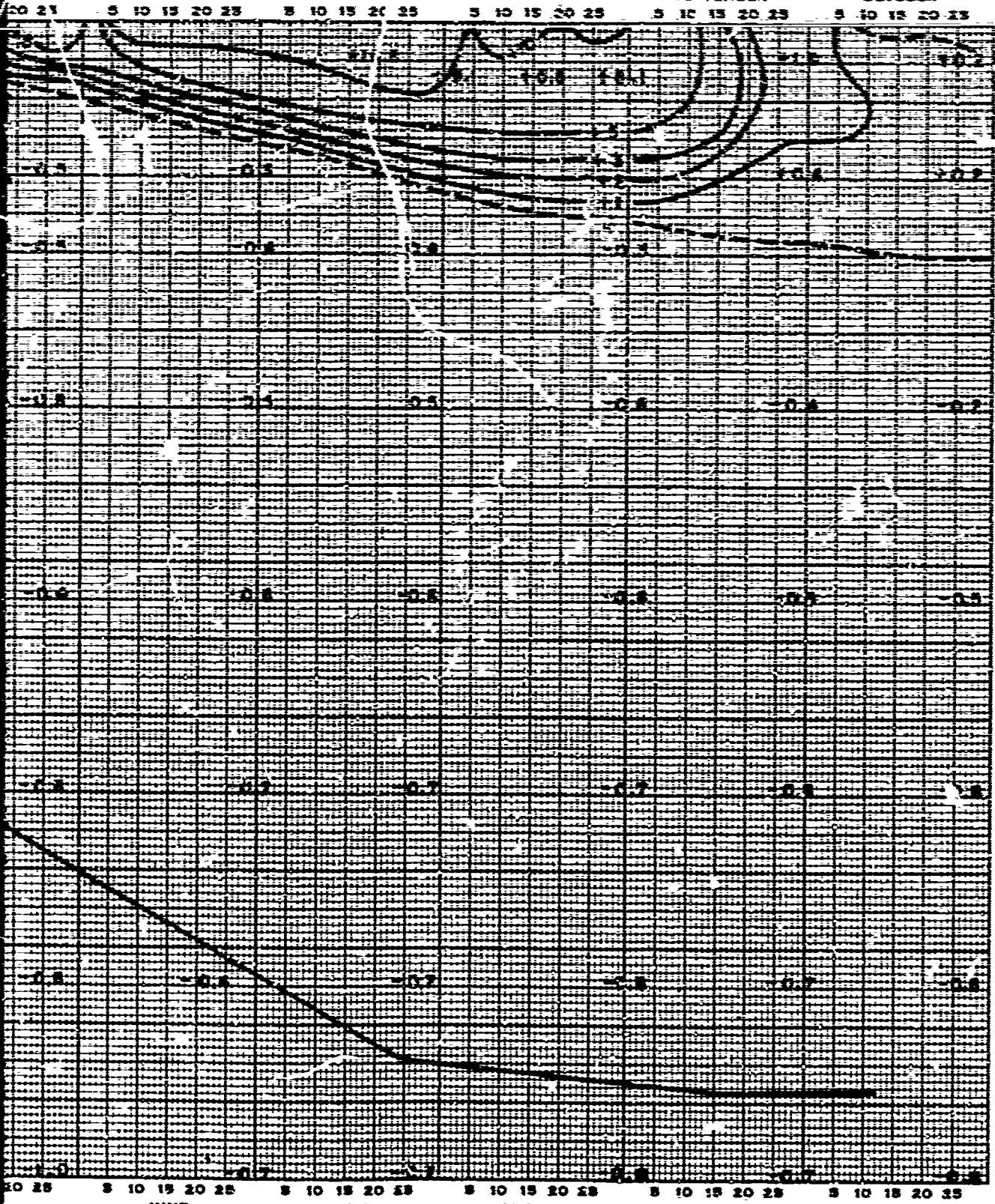

NOTES:
 TEMPERATURES SHOWN IN DEGREES CENTIGRADE.
 HOLE NO. C HAS BEEN CLEARED AND STRIPPED
 OF VEGETATION AND TOP SOIL EXPOSING
 UNDERLYING SILT.

C

PERMAFROST INVESTIGATION
 FIELD RESEARCH-FAIRBANKS, ALASKA
 AREA NO. 1 - HOLE NO. C
 GROUND ISOTHERMS AND SURFACE ELEVATIONS
 1946-47
 CORPS OF ENGINEERS, ST. PAUL, MINN. MAY 1950

1947

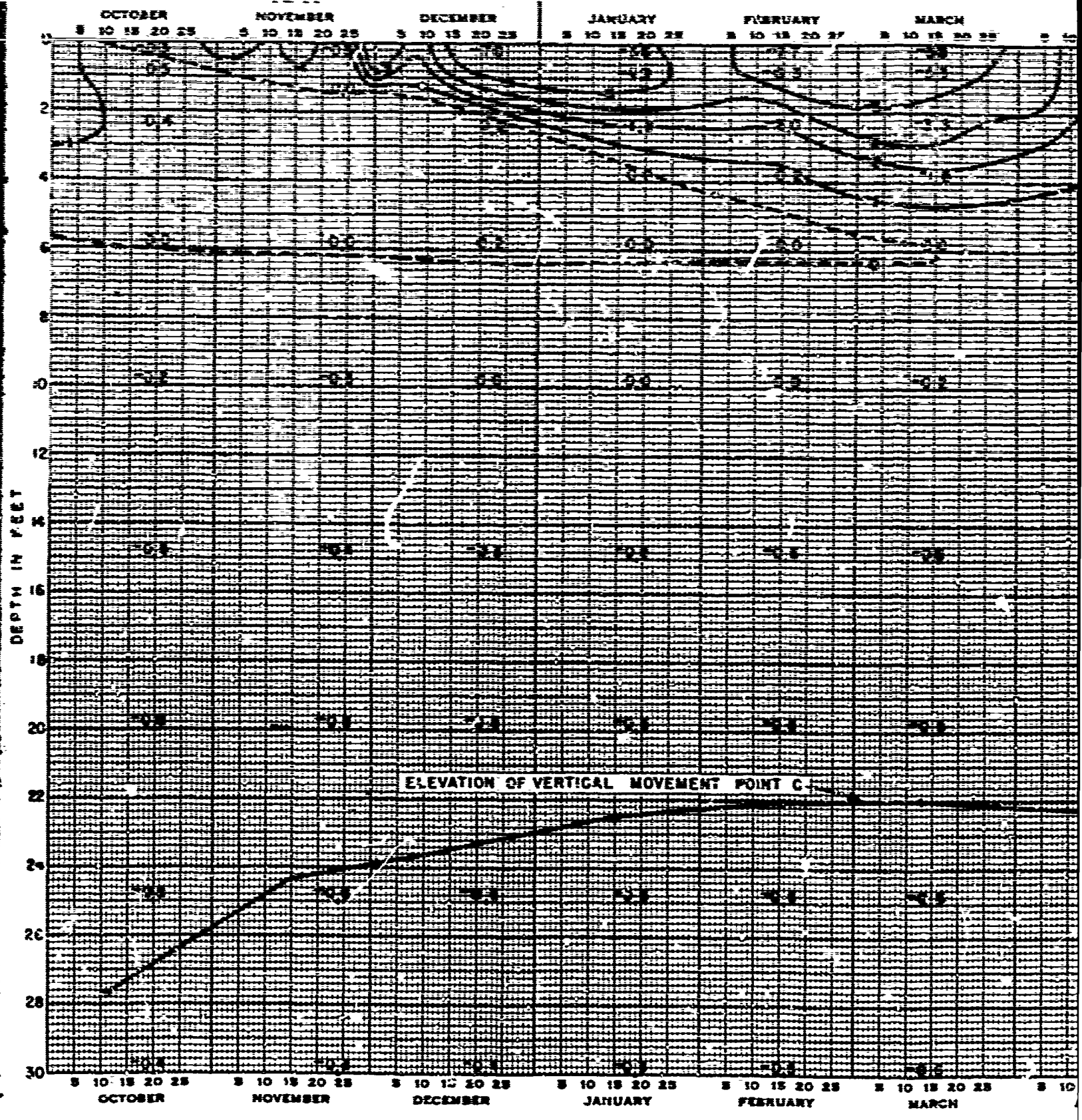

LEGEND

- ZERO ISOTHERM
- ISOTHERMS OTHER THAN ZERO (ABOVE OR BELOW AS MARKED)

A

1948

JANUARY FEBRUARY MARCH APRIL MAY JUNE JULY
5 10 15 20 25 5 10 15 20 25 5 10 15 20 25 5 10 15 20 25 5 10 15 20 25 5 10 15 20 25 5 10 15 20 25

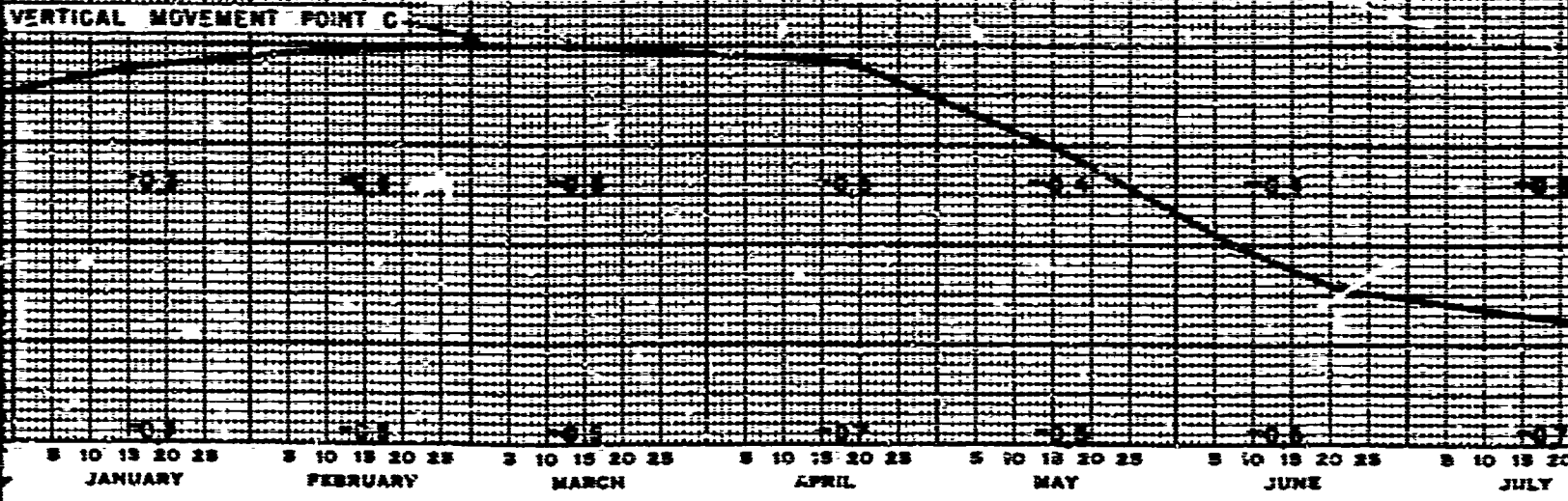
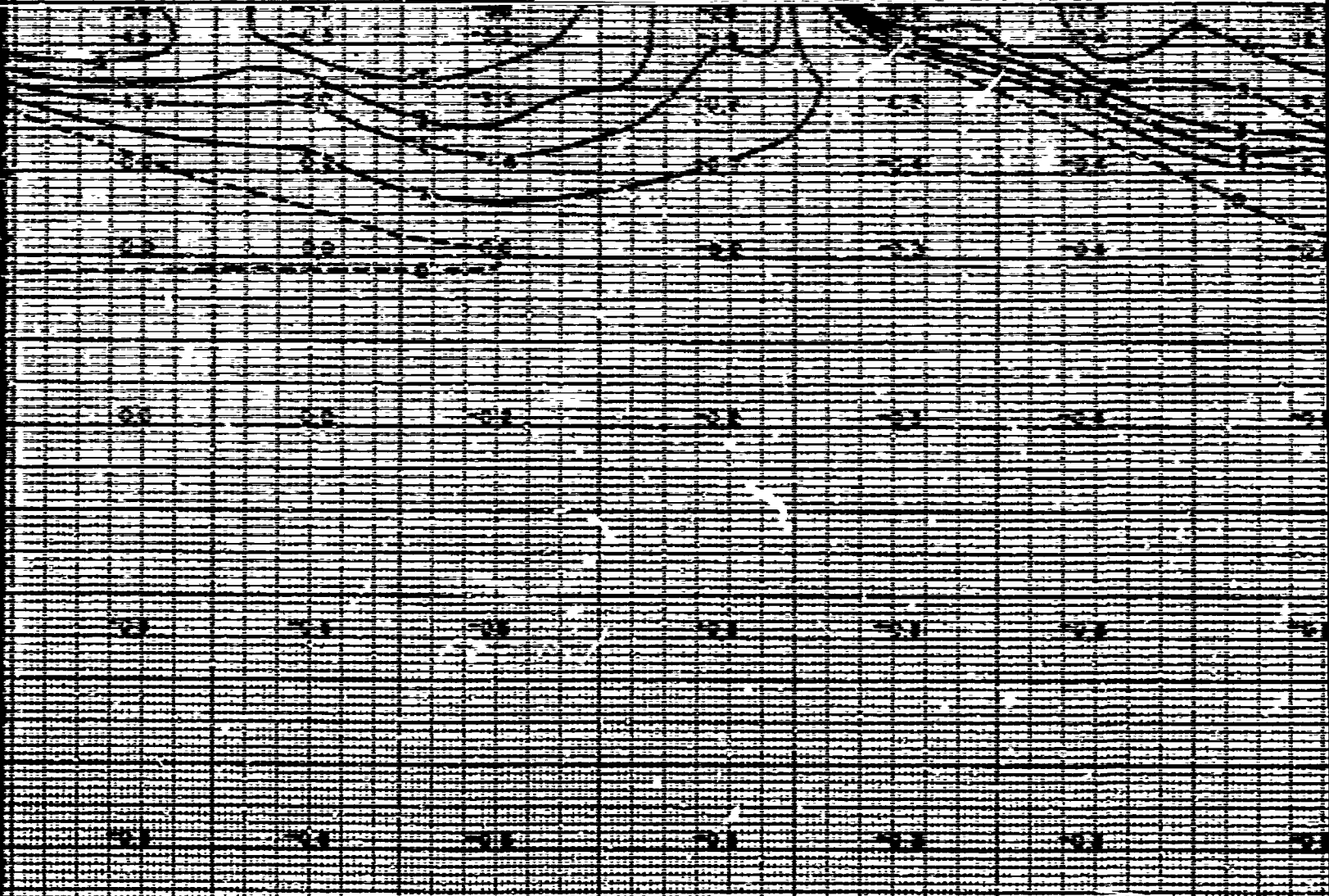

LEGEND

- ZERO ISOTHERM
- ISOTHERMS OTHER THAN ZERO
(ABOVE OR BELOW AS MARKED)



GENERAL NOTES:

ISOTHERMS SHOWN IN DEGREES CENTIGRADE.
SECTION C HAS BEEN CLEARED AND STRIPPED
OF ALL VEGETATION AND TOP SOIL EXPOSING
UNDERLYING SILT.

1948

JUNE

JULY

AUGUST

SEPTEMBER

OCTOBER

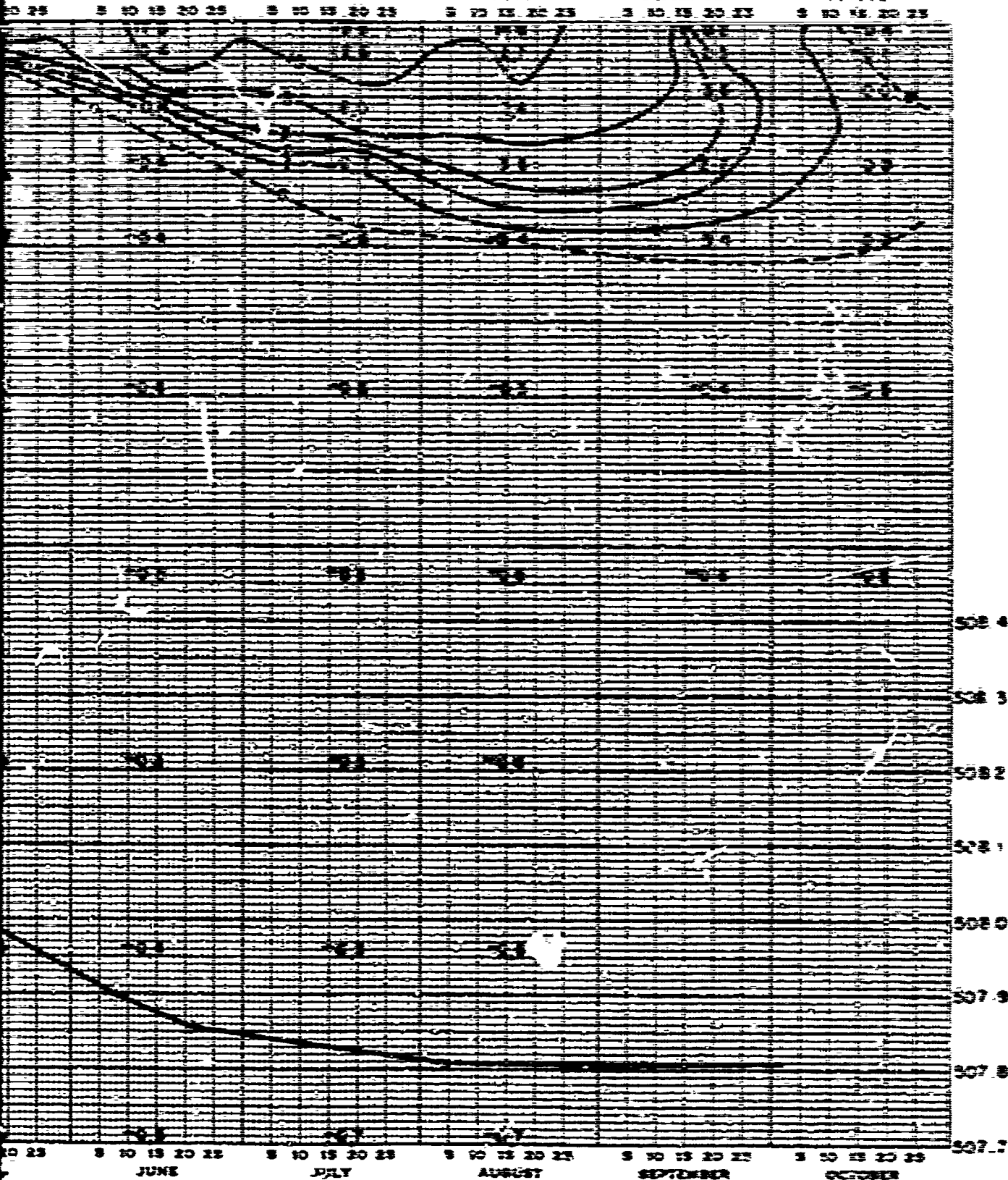

NOTES:
 TEMPERATURES SHOWN IN DEGREES CENTIGRADE.
 HOLE NO. C HAS BEEN CLEARED AND STRIPPED
 OF VEGETATION AND TOP SOIL EXPOSING
 SILT.



PERMAFROST INVESTIGATION
 FIELD RESEARCH-FARSBANKS, ALASKA
 AREA NO. 1 - HOLE NO. C
 GROUND ISOTHERMS AND SURFACE ELEVATIONS
 1947-48
 CORPS OF ENGINEERS, ST. PETERSBURG, FLORIDA, MAY 1950

1947

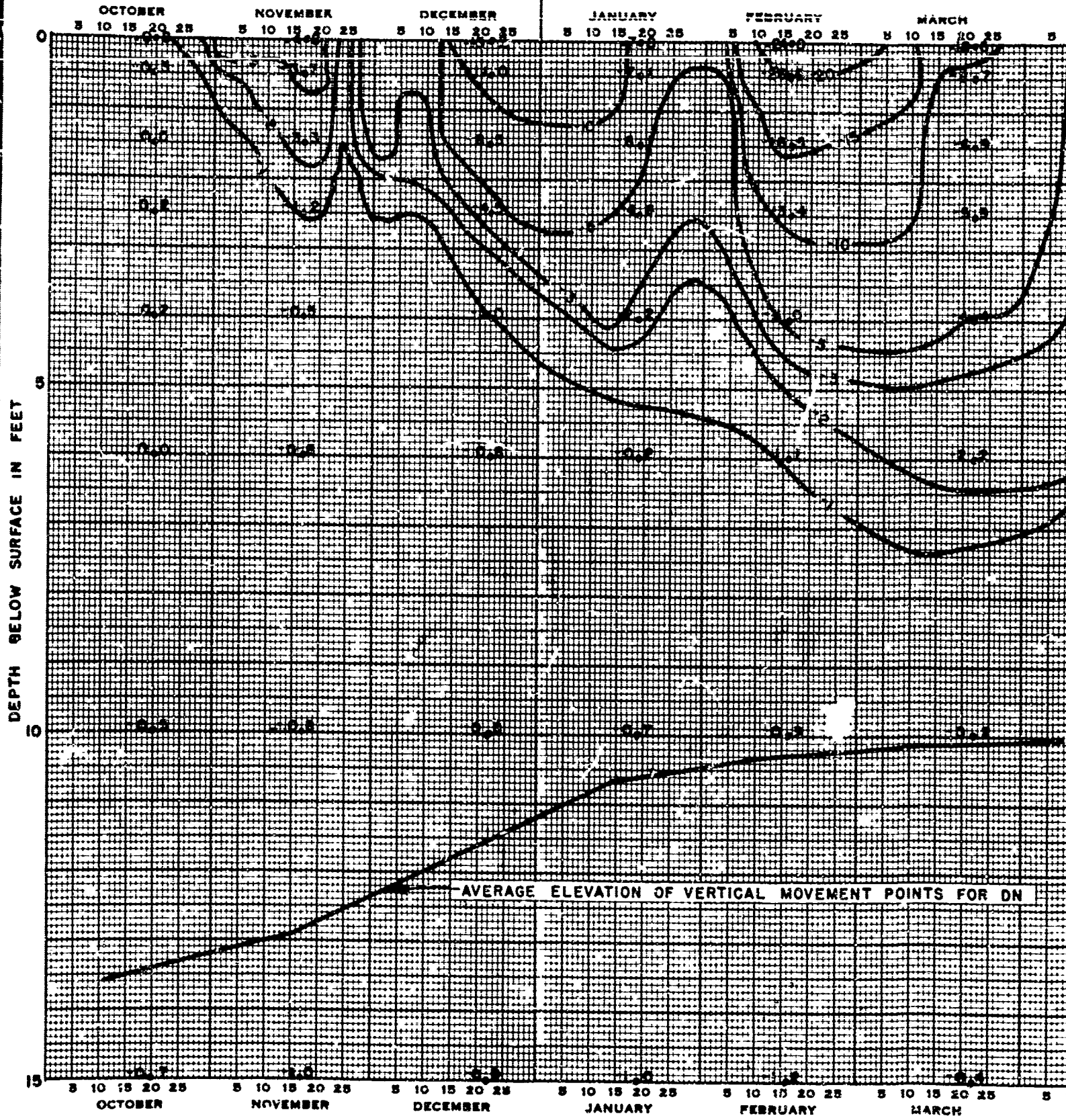

LEGEND

- ZERO ISOTHERM
- ISOTHERMS OTHER THAN ZERO (ABOVE OR BELOW AS MARKED)

A

1948

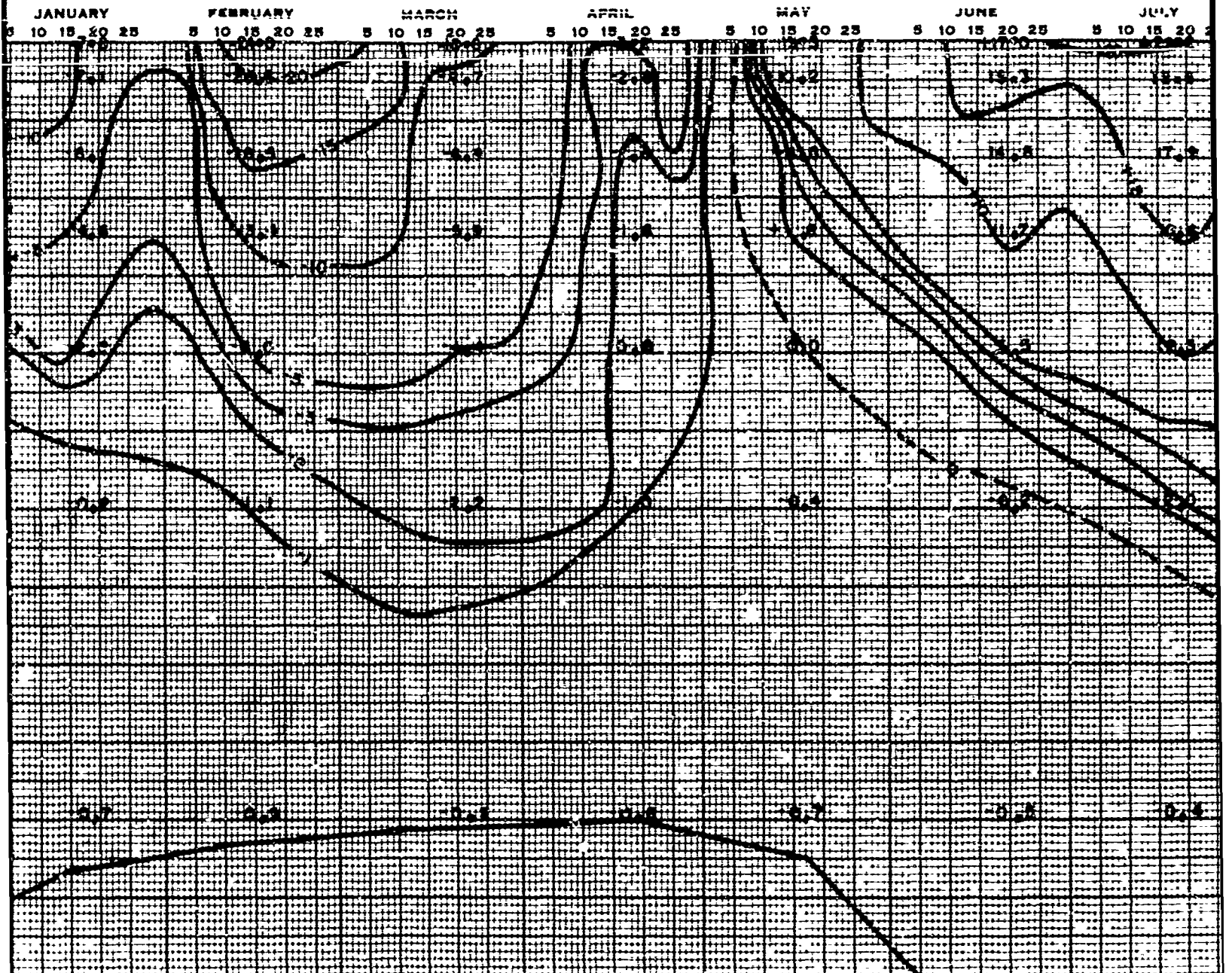

LEVATIO: OF VERTICAL MOVEMENT POINTS FOR DN

JANUARY FEBRUARY MARCH APRIL MAY JUNE JULY

5 10 15 20 25 5 10 15 20 25 5 10 15 20 25 5 10 15 20 25 5 10 15 20 25 5 10 15 20 25 5 10 15 20 25

LEGEND

- ZERO ISOTHERM
- ISOTHERMS OTHER THAN ZERO
(ABOVE OR BELOW AS MARKED)

B

GENERAL NOTES:

ISOTHERMS SHOWN IN DEGREES CENTIGRADE

1948

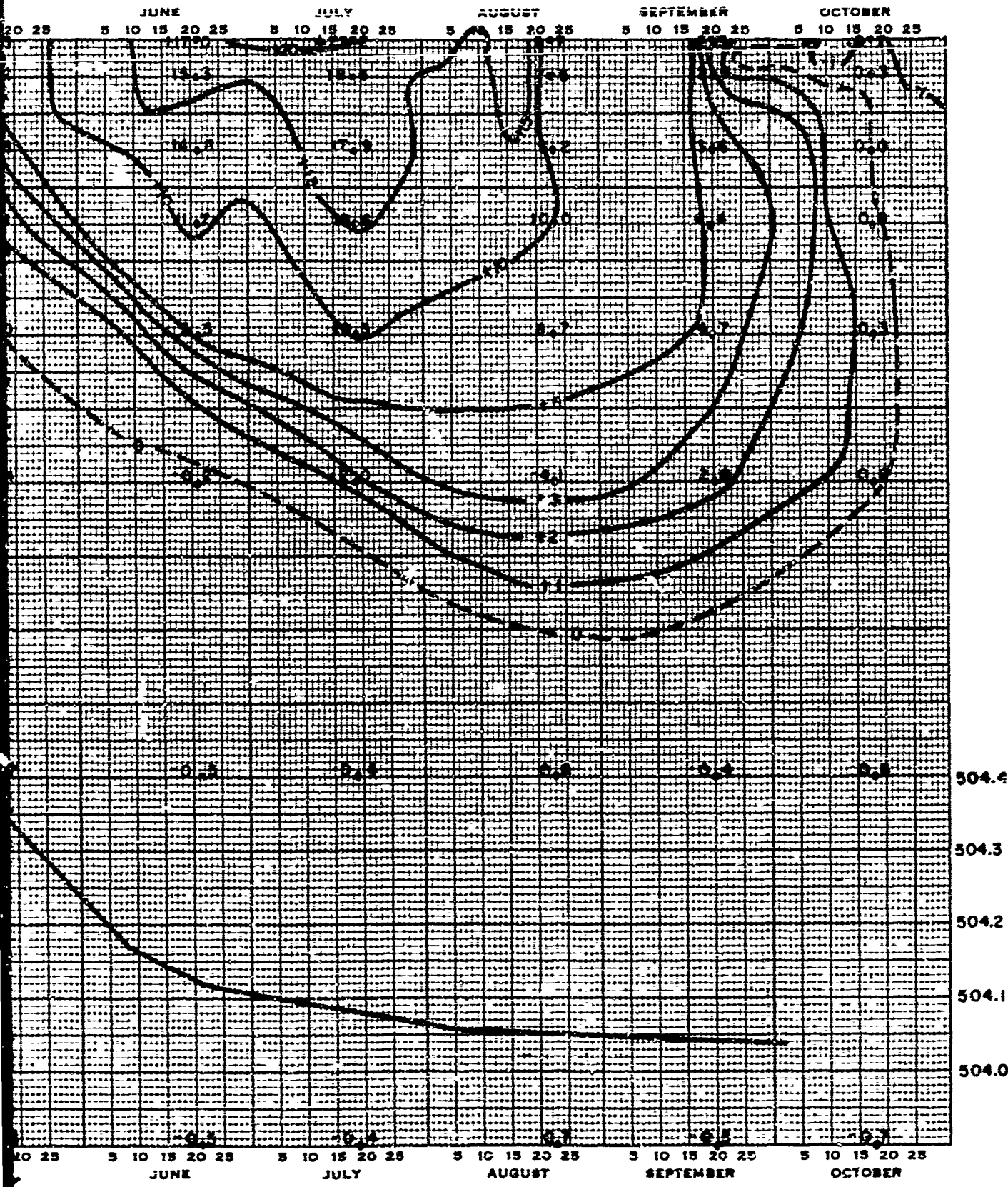

NOTES:
 TEMPERATURES SHOWN IN DEGREES CENTIGRADE



PERMAFROST INVESTIGATION
 FIELD RESEARCH-FAIRBANKS, ALASKA
 AREA NO. 1-HOLE NO. DN
 GROUND ISOTHERMS AND SURFACE ELEVATIONS
 1947 - 1948
 CORPS OF ENGINEERS, ST. PAUL, MINN. MAY 1950

PLATE III-18

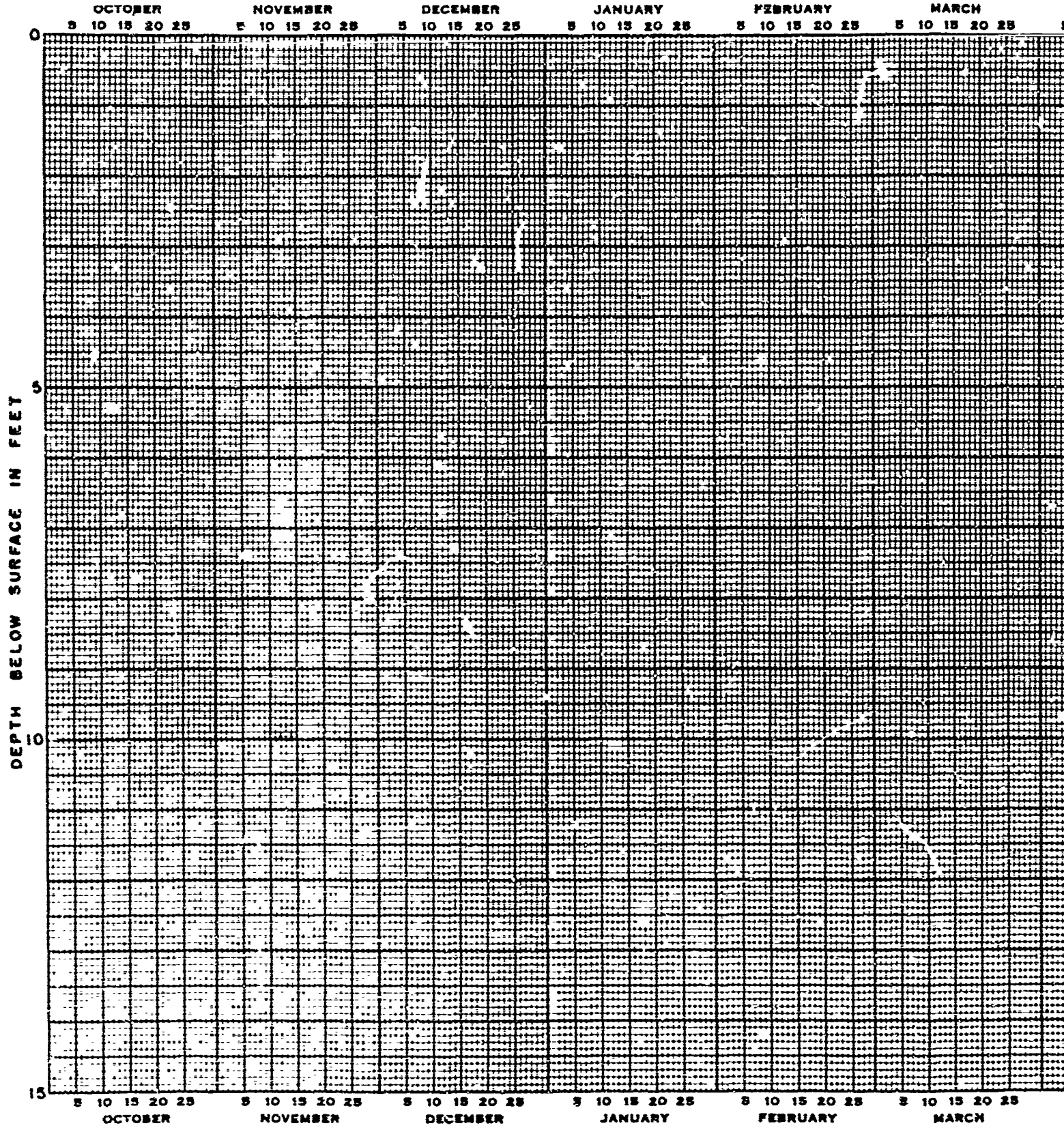

A

LEGEND

- ZERO ISOTHERM
- ISOTHERMS OTHER THAN ZER

1948

JANUARY

FEBRUARY

MARCH

APRIL

MAY

JUNE

JULY

5 10 15 20 25 5 10 15 20 25 5 10 15 20 25 5 10 15 20 25 5 10 15 20 25 5 10 15 20 25 5 10 15 20 25

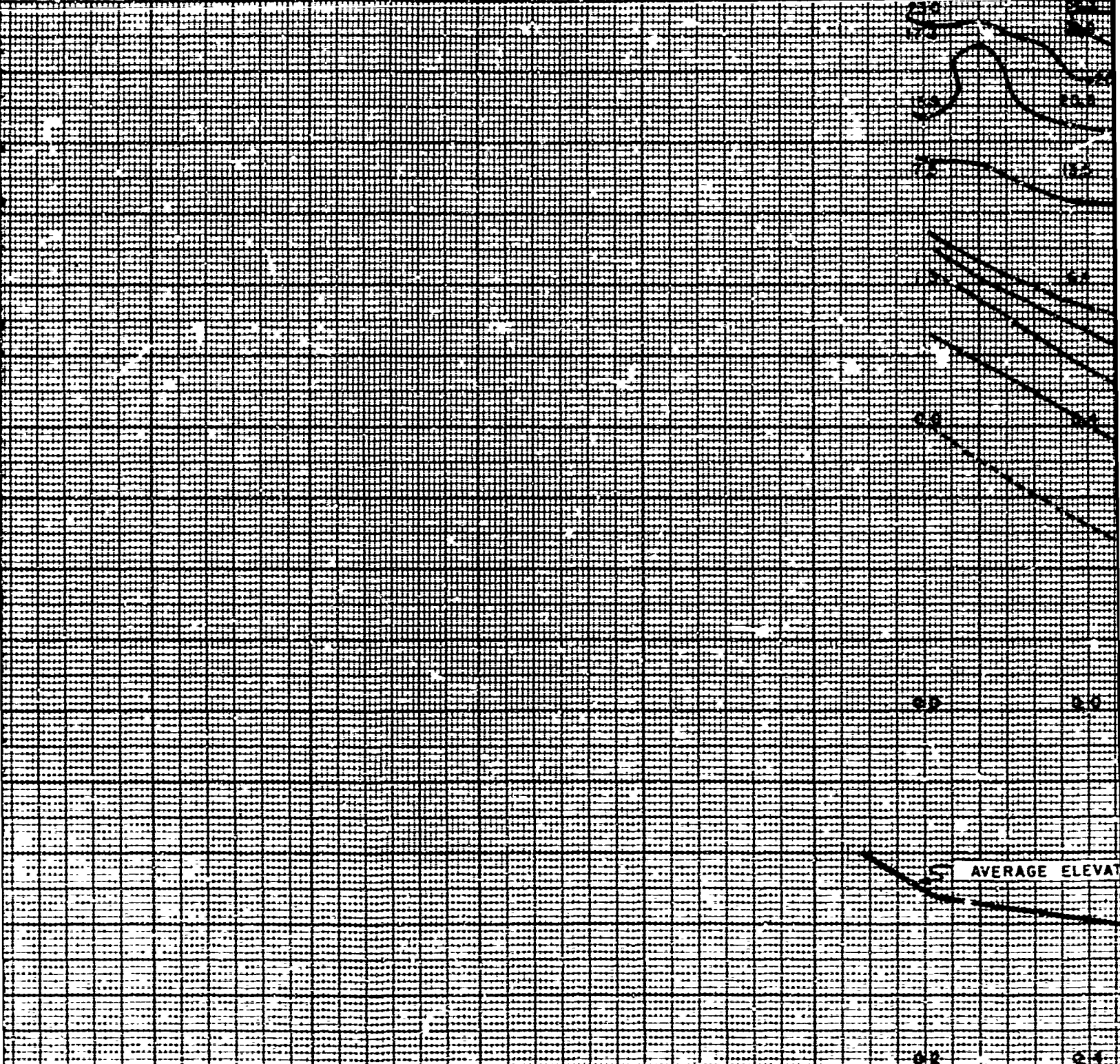

5 10 15 20 25 5 10 15 20 25 5 10 15 20 25 5 10 15 20 25 5 10 15 20 25 5 10 15 20 25

JANUARY FEBRUARY MARCH APRIL MAY JUNE JULY

LEGEND

- ZERO ISOTHERM
- ISOTHERMS OTHER THAN ZERO

B

GENERAL NOTES

ISOTHERMS SHOWN IN DEGREES

1948

JUNE

JULY

AUGUST

SEPTEMBER

OCTOBER

20 25 5 10 15 20 25 5 10 15 20 25 5 10 15 20 25 5 10 15 20 25 5 10 15 20 25

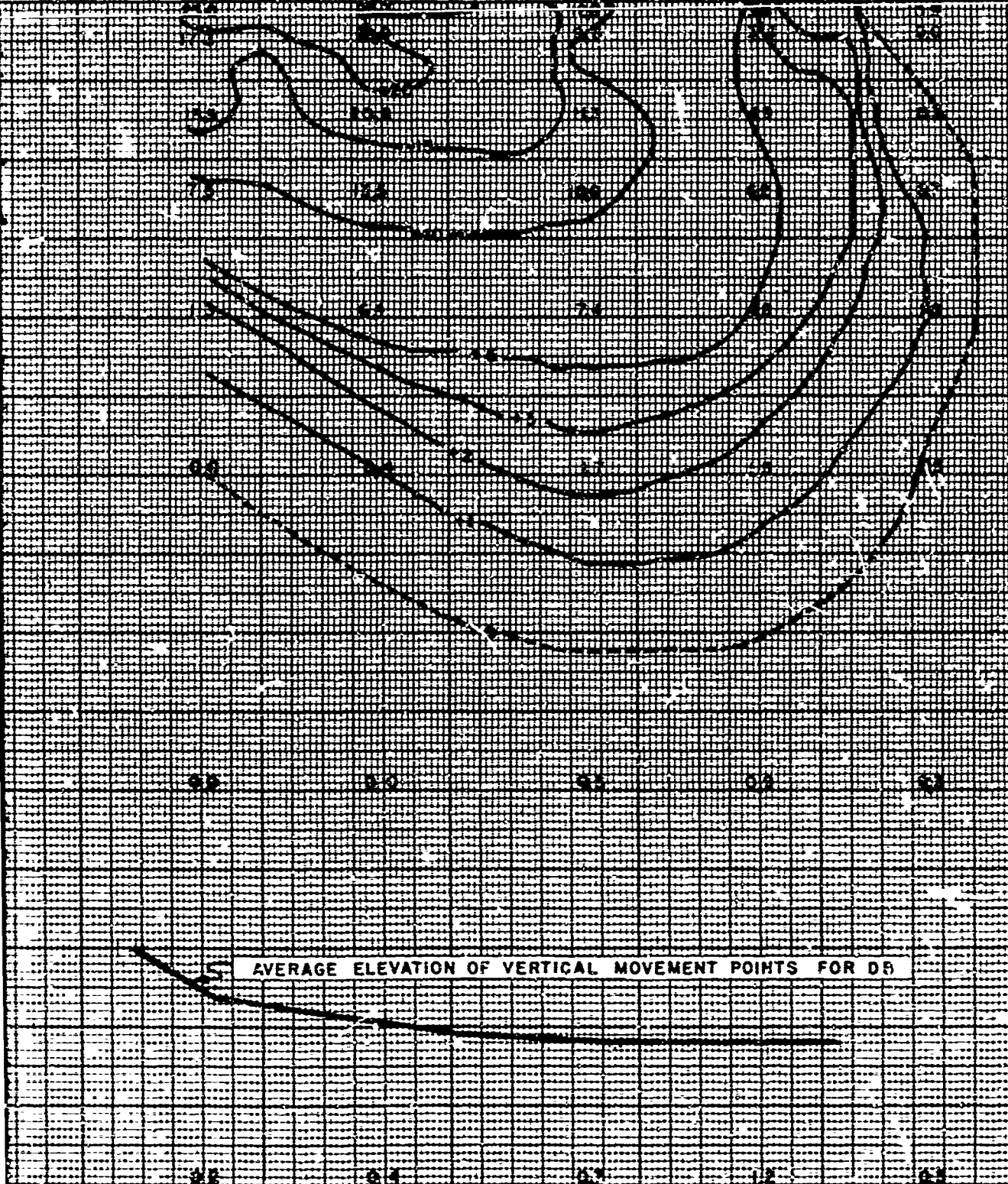

20 25 5 10 15 20 25 5 10 15 20 25 5 10 15 20 25 5 10 15 20 25 5 10 15 20 25

JUNE

JULY

AUGUST

SEPTEMBER

OCTOBER

PERMAFROST INVESTIGATION

FIELD RESEARCH - FAIRBANKS, ALASKA

AREA NO 1 - HOLE NO. DB

GROUND ISOTHERMS AND SURFACE ELEVATIONS
1948

CORPS OF ENGINEERS, ST. PAUL, MINN. MAY 1950

GENERAL NOTES

ISOTHERMS SHOWN IN DEGREES CENTIGRADE

C

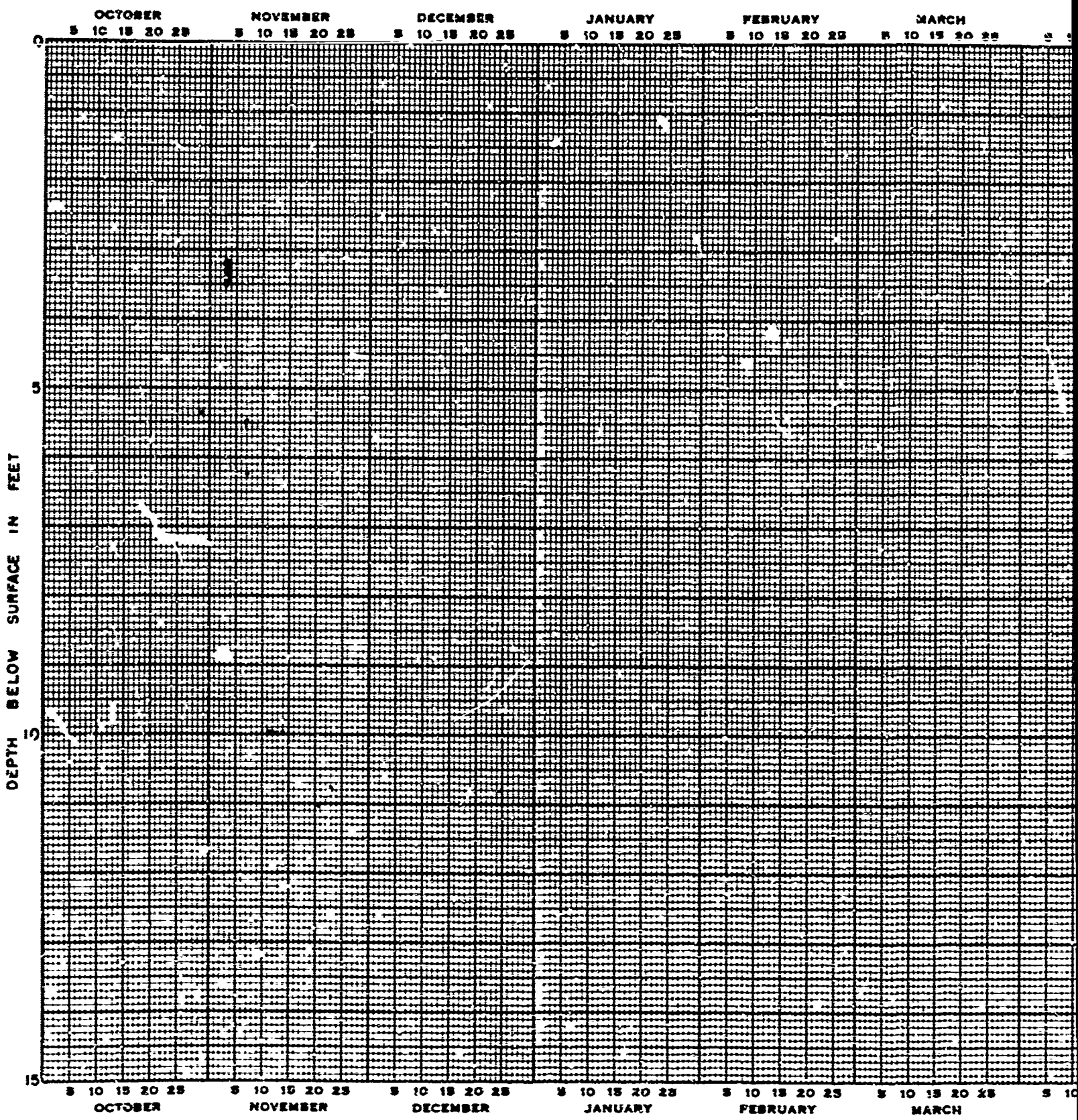

LEGEND

- ZERO ISOTHERM
- ISOTHERMS OTHER THAN ZERO
(ABOVE OR BELOW AS MARKED)

A

1948

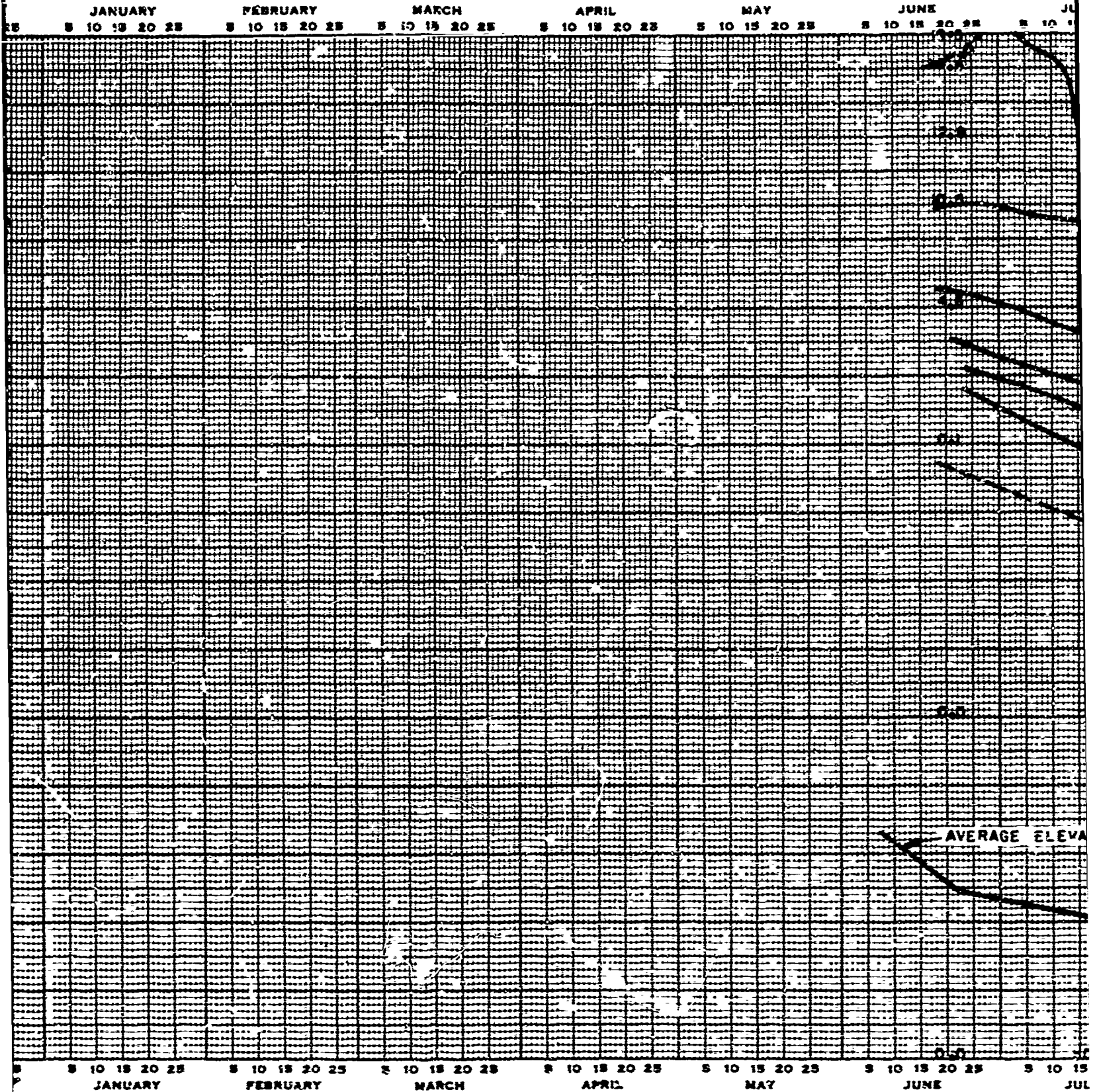

LEGEND

- ZERO ISOTHERM
- ISOTHERMS OTHER THAN ZERO
(ABOVE OR BELOW AS MARKED)

B

GENERAL NOTES:

ISOTHERMS SHOWN IN DEGREES CENTIGRAD

1948

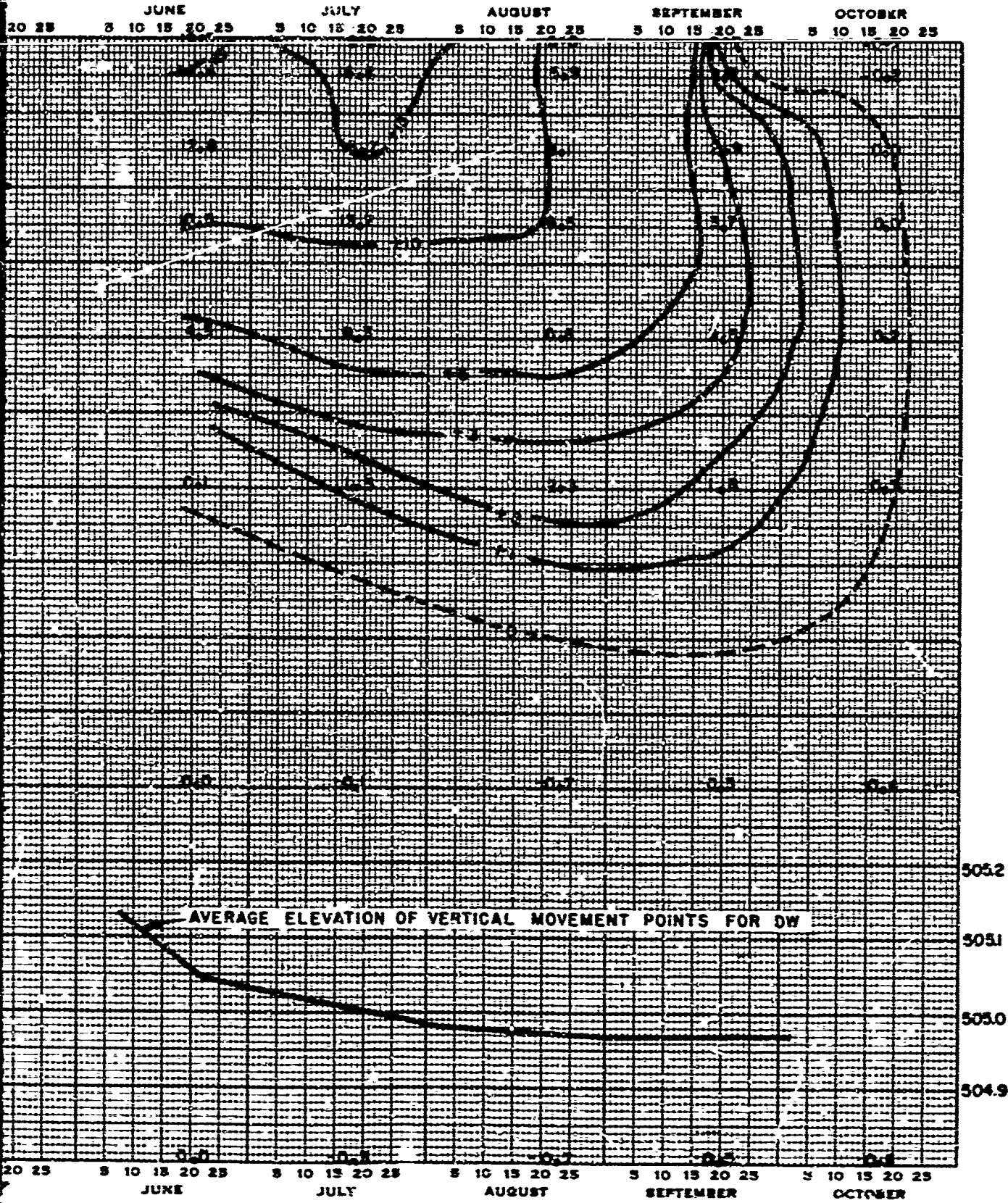

NOTES:
 ISOTHERMS SHOWN IN DEGREES CENTIGRADE.

C

PERMAFROST INVESTIGATION
 FIELD RESEARCH-FAIRBANKS, ALASKA
 AREA NO. 1-HOLE NO. DW
 GROUND ISOTHERMS AND SURFACE ELEVATIONS
 1948

CORPS OF ENGINEERS, ST. PAUL, MINN. MAY 1950

1946

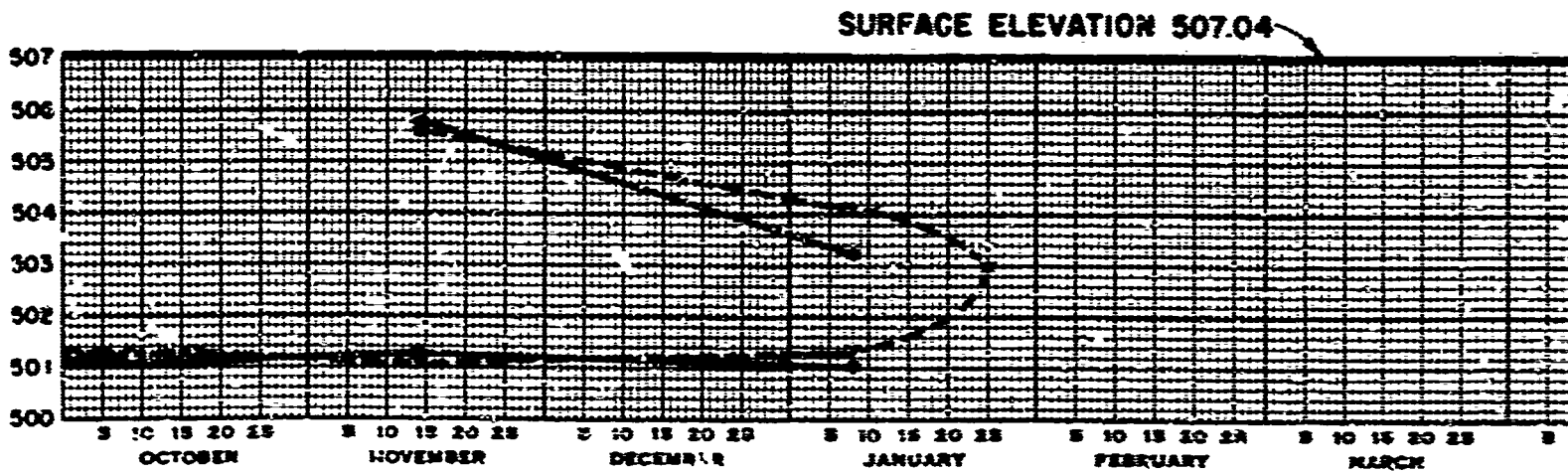
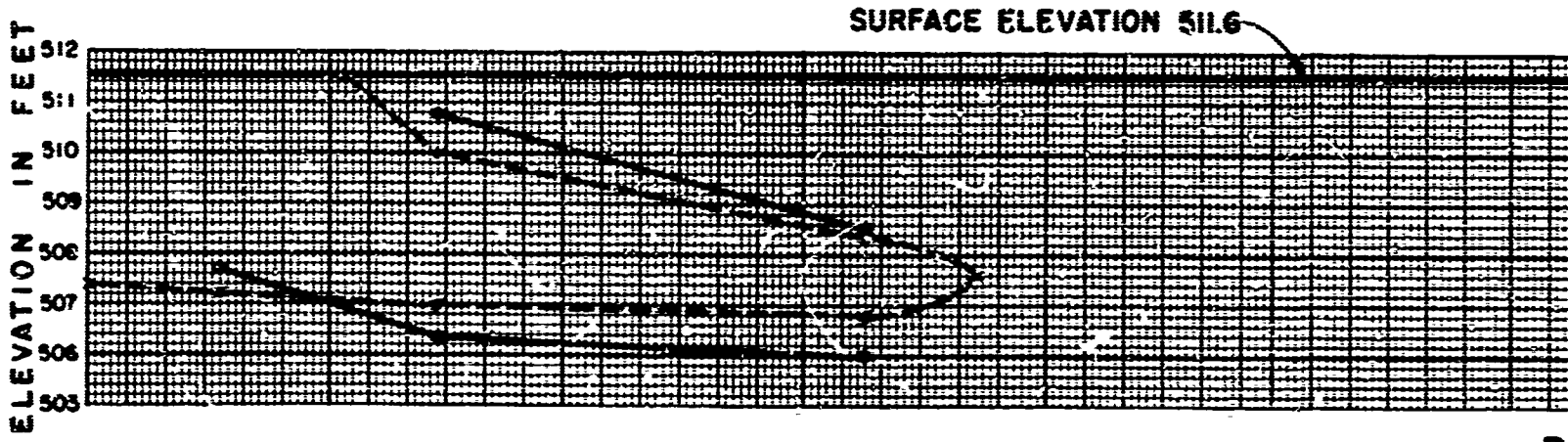
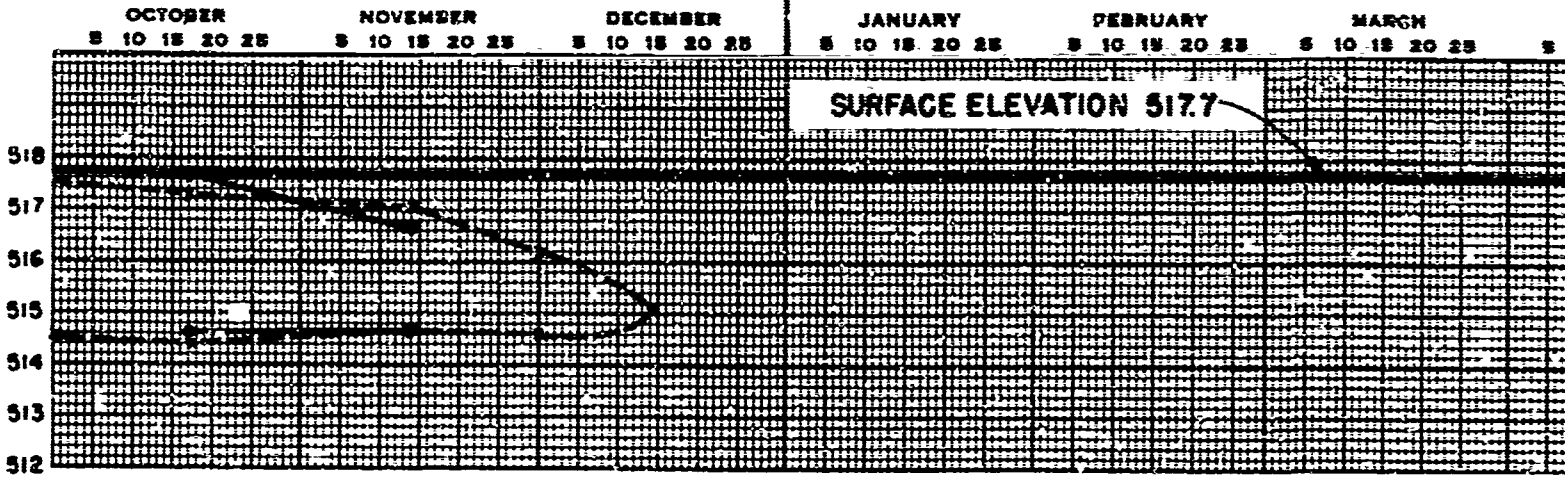

A

1947

JANUARY

FEBRUARY

MARCH

APRIL

MAY

JUNE

JULY

SURFACE ELEVATION 517.7

POINT A

SURFACE ELEVATION 511.6

POINT B

SURFACE ELEVATION 507.04

POINT C

LEGEND

- FROST LINE AND PERMAFROST TABLE AS DETERMINED BY PROSING.
- x— ZERO DEGREE CENTIGRADE ISOTHERM AS DETERMINED BY GROUND TEMPERATURE READING.

B

1947

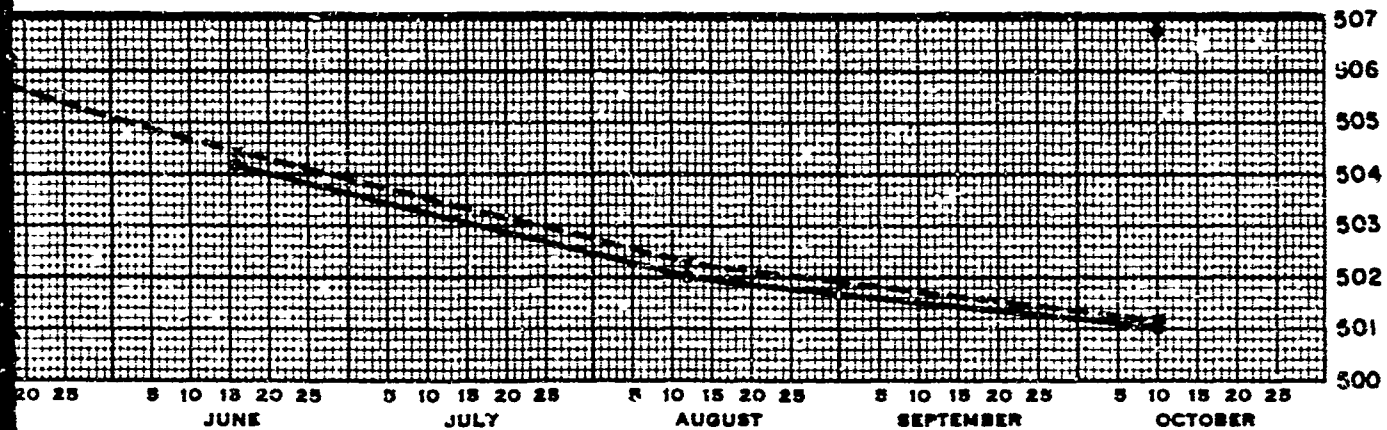
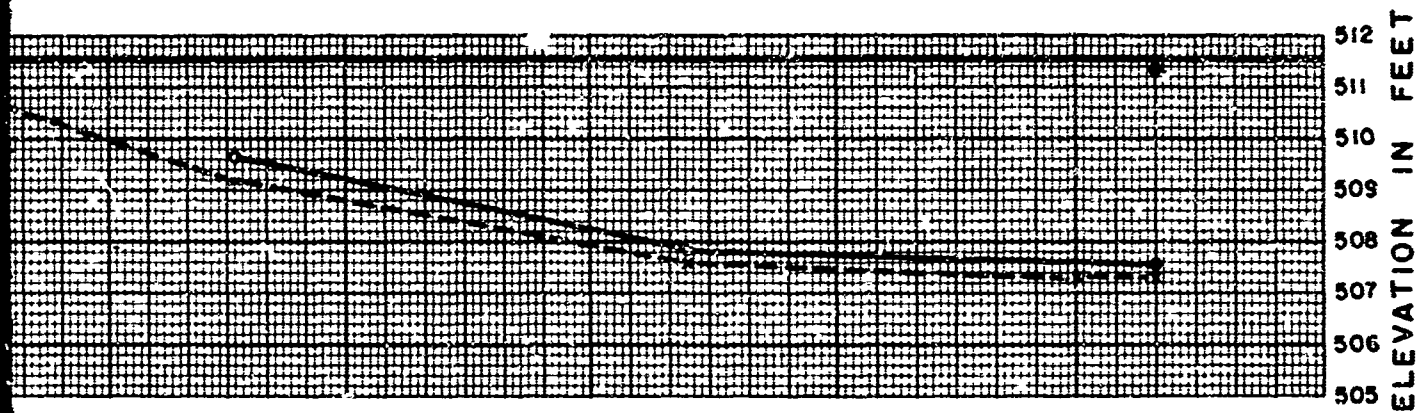
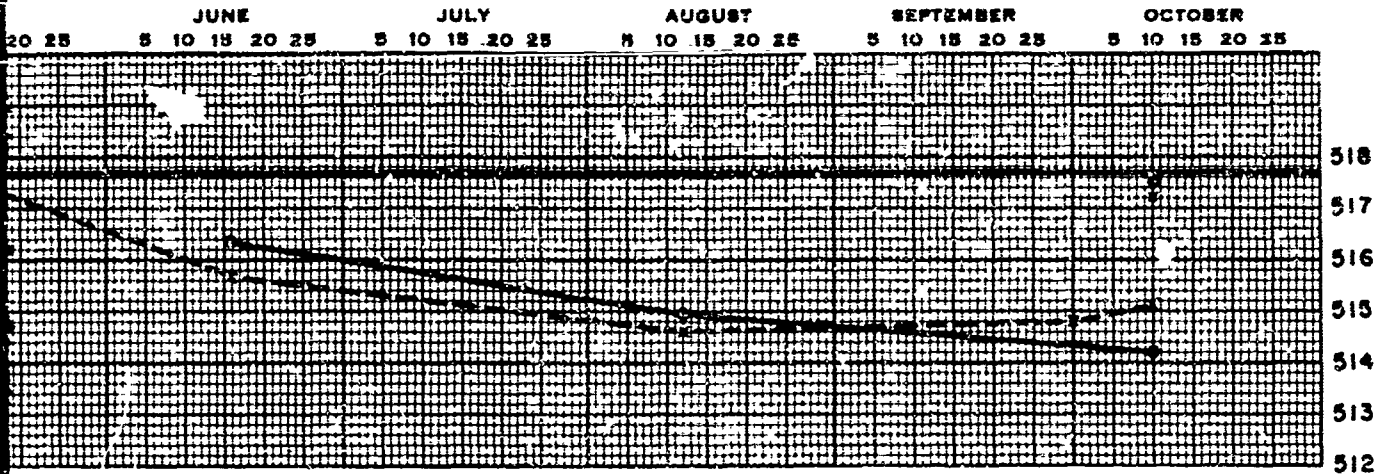

LEGEND

SOLID LINE AND PERMAFROST TABLE
 DETERMINED BY PROBING.
 DASHED LINE AND PERMAFROST TABLE
 DETERMINED BY GROUND TEMPERATURE
 PROBING.



**PERMAFROST INVESTIGATION
 FIELD RESEARCH, FAIRBANKS, ALASKA
 AREA NO. 1**

**DEPTH OF THAW OBTAINED BY
 PROBING - GROUND TEMPERATURES
 1946 - 47**

CORPS OF ENGINEERS, ST. PAUL, MINN. MAY, 1950

1947

OCTOBER

NOVEMBER

DECEMBER

JANUARY

FEBRUARY

MARCH

5 10 15 20 25

5 10 15 20 25

5 10 15 20 25

5 10 15 20 25

5 10 15 20 25

5 10 15 20 25

5

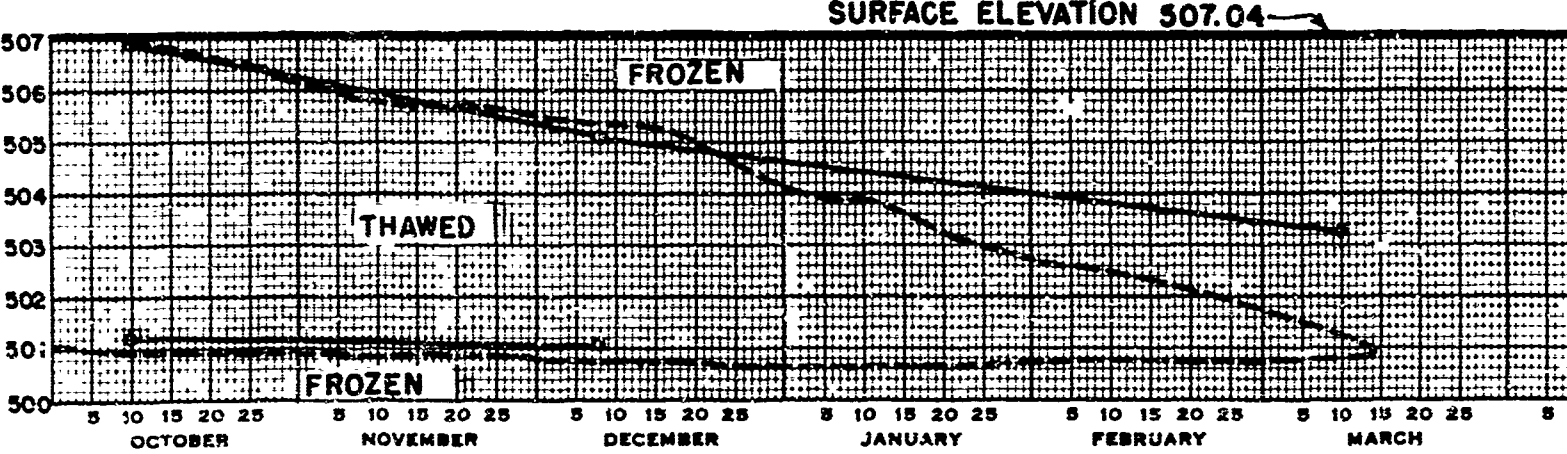
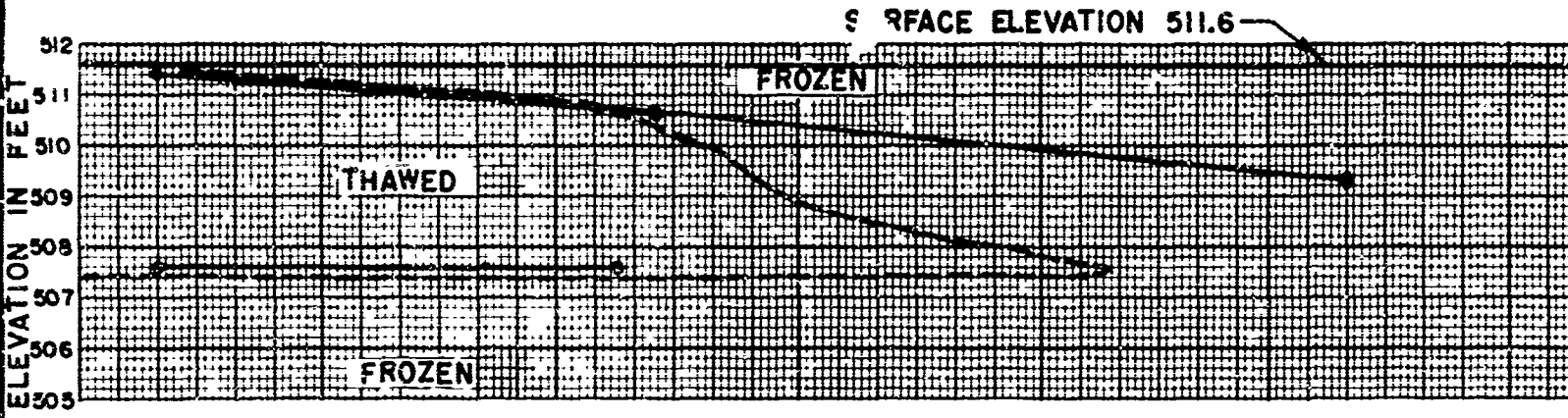
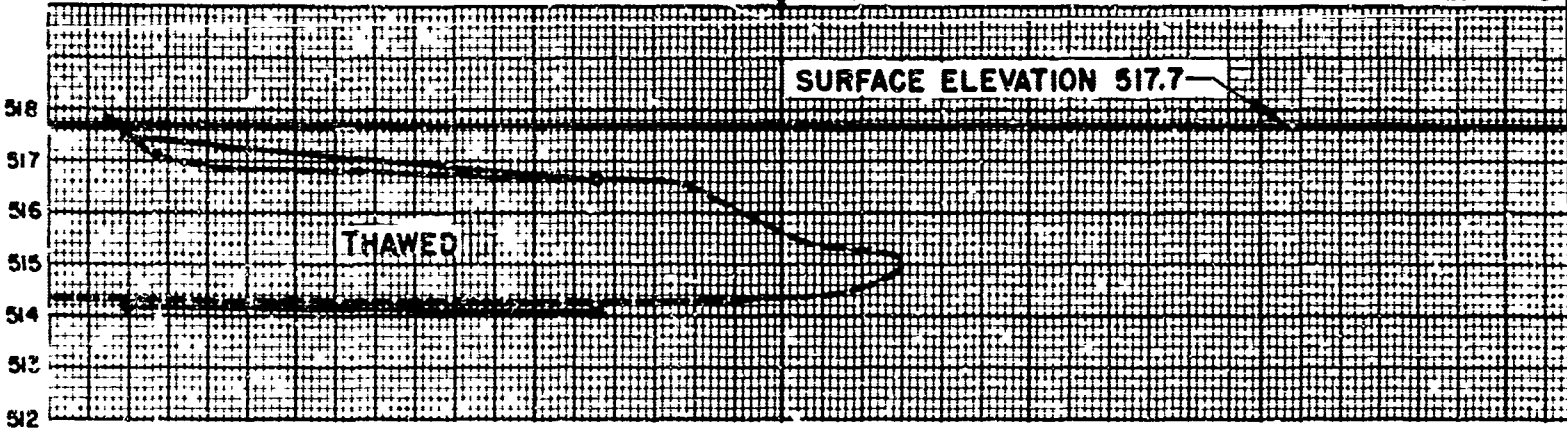

A

LEGEND

- FROST LINE AND PERMAFROST TABLE AS DETERMINED BY PROBING
- - - - - ZERO DEGREE CENTIGRADE ISOTHERMS AS DETERMINED BY GROUND TEMPERATURE READING

194

JANUARY

FEBRUARY

MARCH

APRIL

MAY

JUNE

JULY

5 10 15 20 25

5 10 15 20 25

5 10 15 20 25

5 10 15 20 25

5 10 15 20 25

5 10 15 20 25

5 10 15

SURFACE ELEVATION 517.7

POINT A

SURFACE ELEVATION 511.6

THAW

FROZE

POINT B

SURFACE ELEVATION 507.04

FROZEN

5 10 15 20 25

5 10 15 20 25

5 10 15 20 25

5 10 15 20 25

5 10 15 20 25

5 10 15 20 25

5 10 15 20

JANUARY

FEBRUARY

MARCH

APRIL

MAY

JUNE

JULY

POINT C

LEGEND

- FROST LINE AND PERMAFROST TABLE AS DETERMINED BY PROBING
- - - - - ZERO DEGREE CENTIGRADE ISOTHERMS AS DETERMINED BY GROUND TEMPERATURE READING

B

1948

JUNE

JULY

AUGUST

SEPTEMBER

OCTOBER

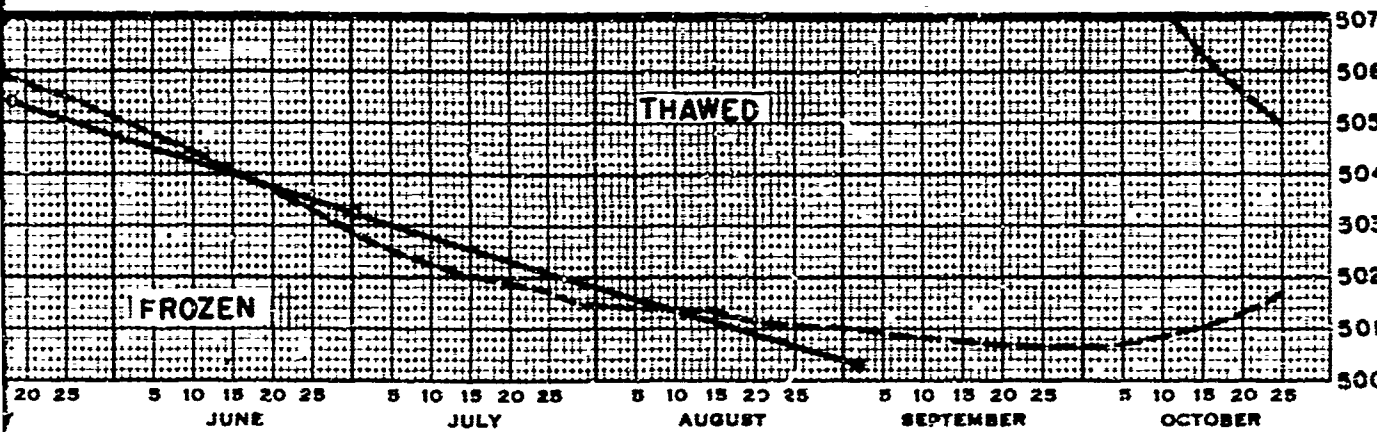
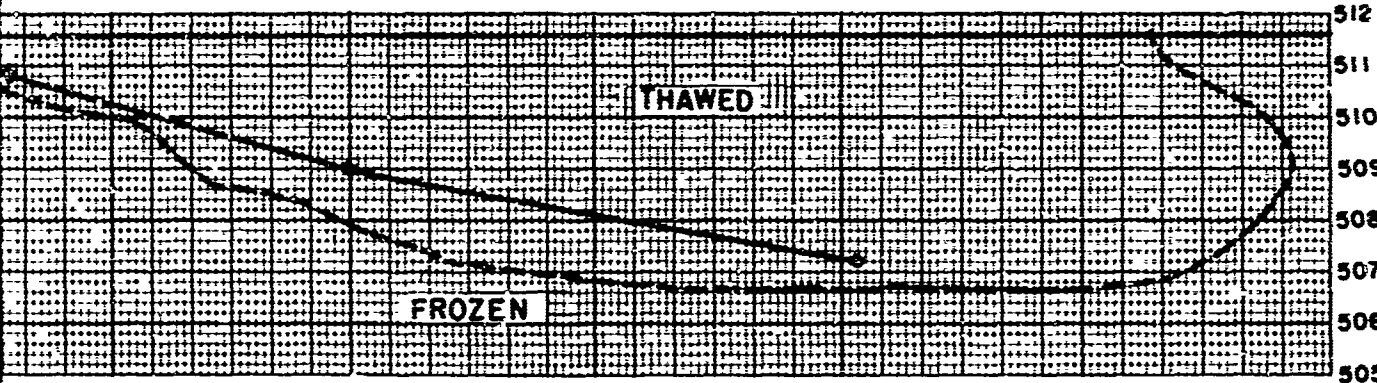
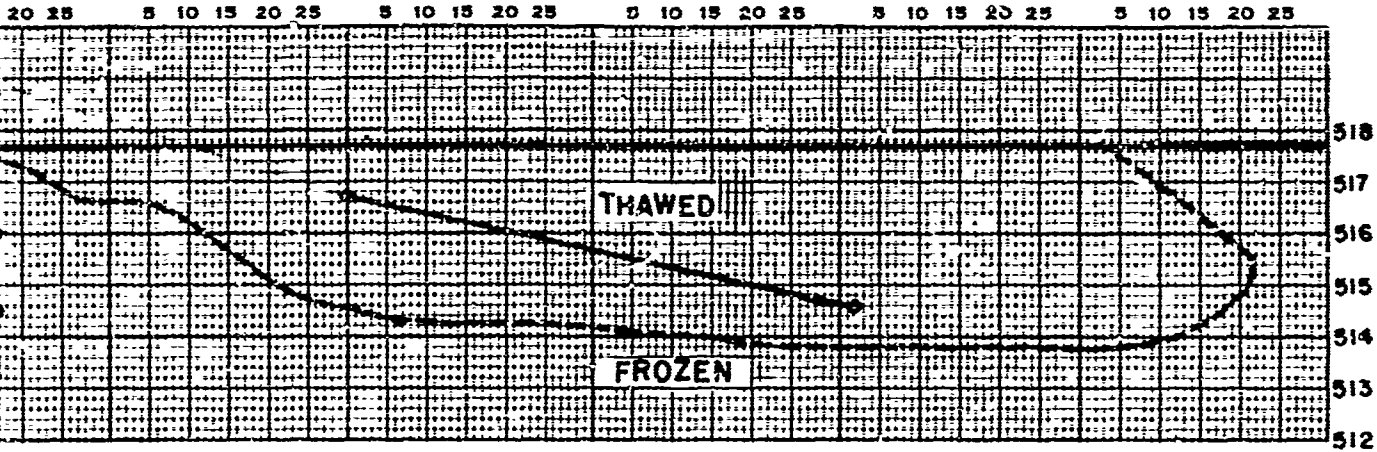

ELEVATION IN FEET

PERMAFROST INVESTIGATION
FIELD RESEARCH-FAIRBANKS ALASKA
AREA NO. 1
DEPTH OF THAW OBTAINED BY
PROBING - GROUND TEMPERATURES
1947 - 48

CORPS OF ENGINEERS, ST. PAUL, MINN. MAY. 1950

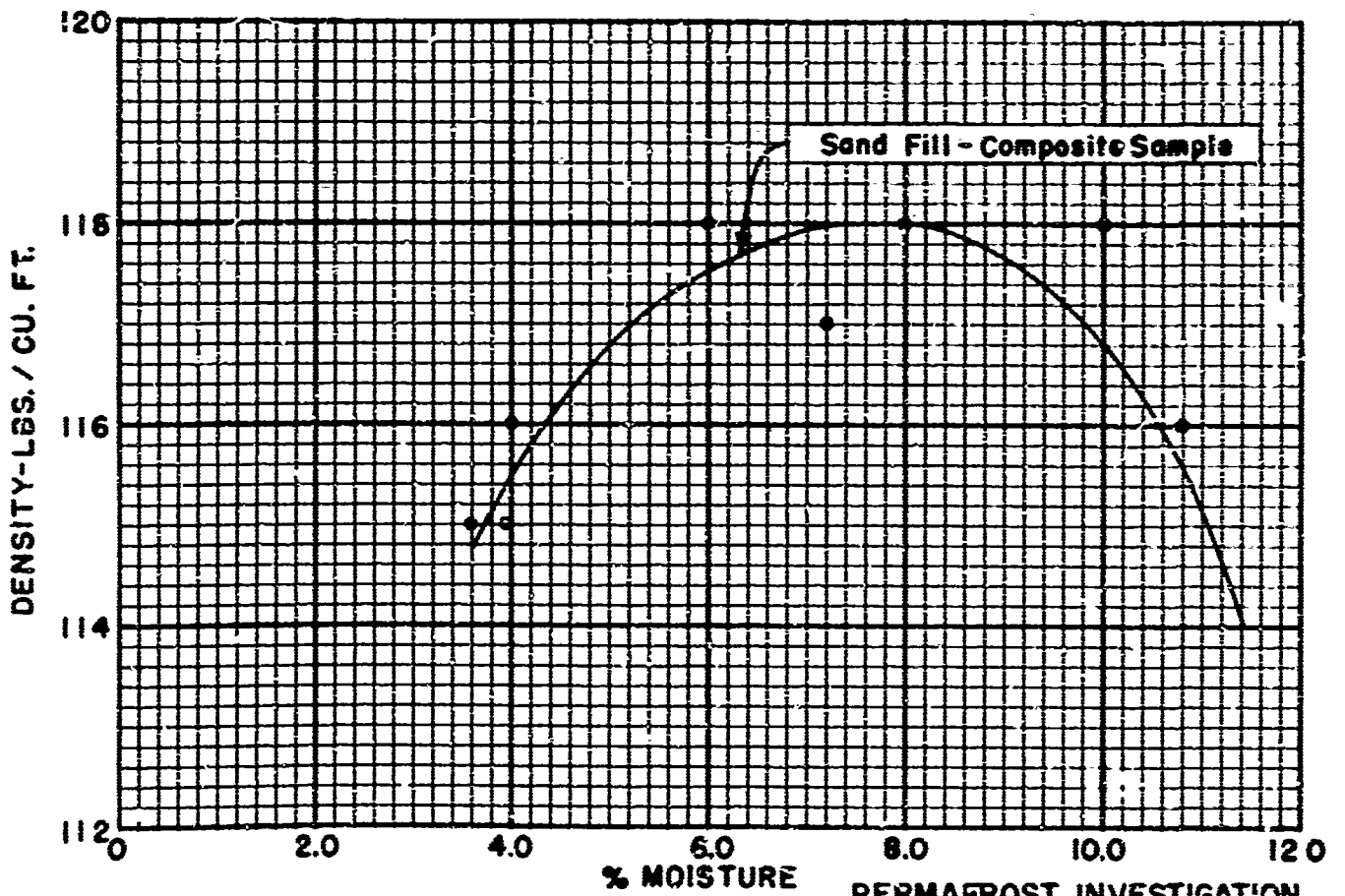
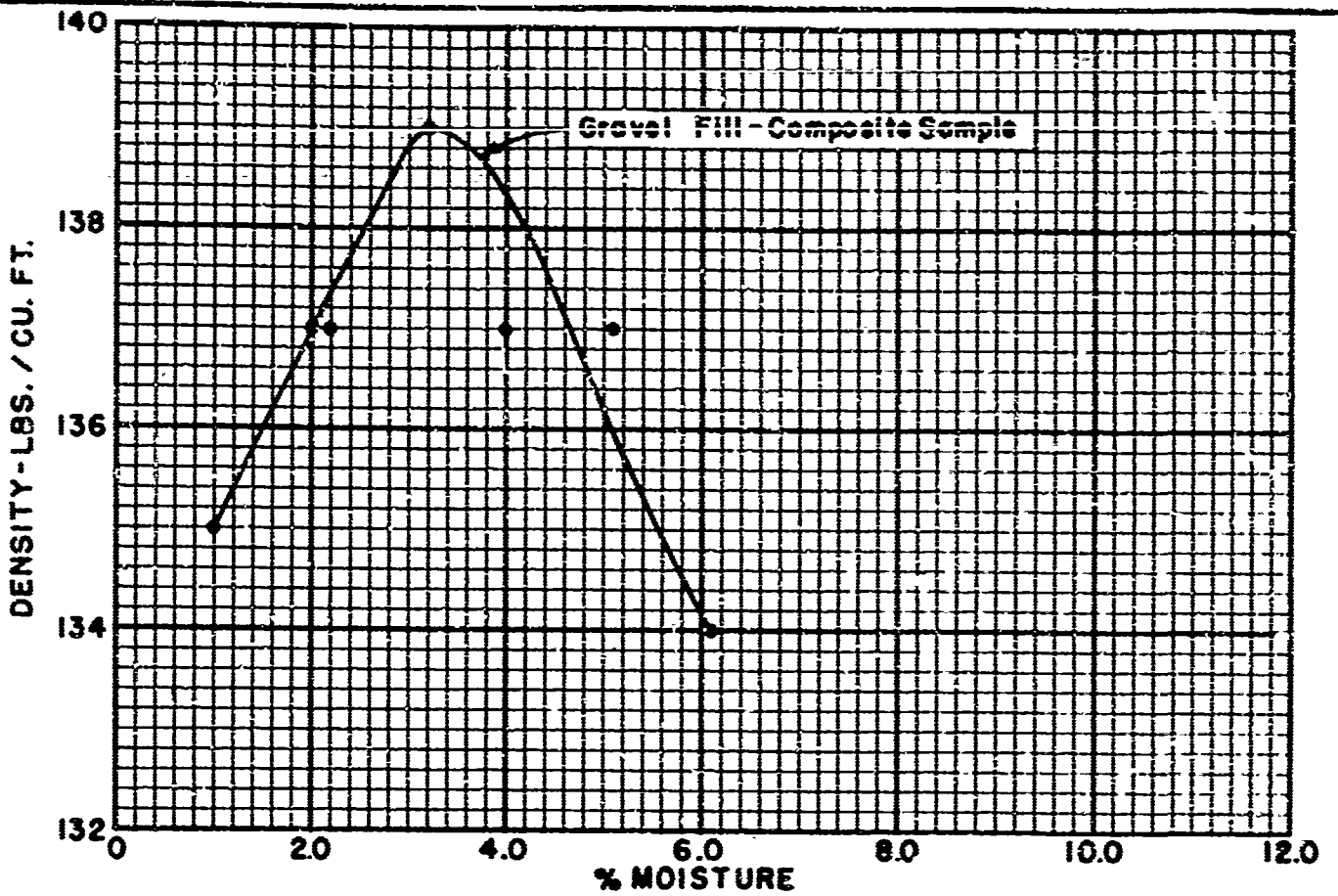

PERMAFROST INVESTIGATION
 FIELD RESEARCH-FAIRBANKS, ALASKA
 BACKFILL MATERIAL - AREA 2 & 3
 MOISTURE-DENSITY CURVES
 CORPS OF ENGINEERS, ST. PAUL, MINN. MAY 1950

MECHANICAL ANALYSIS

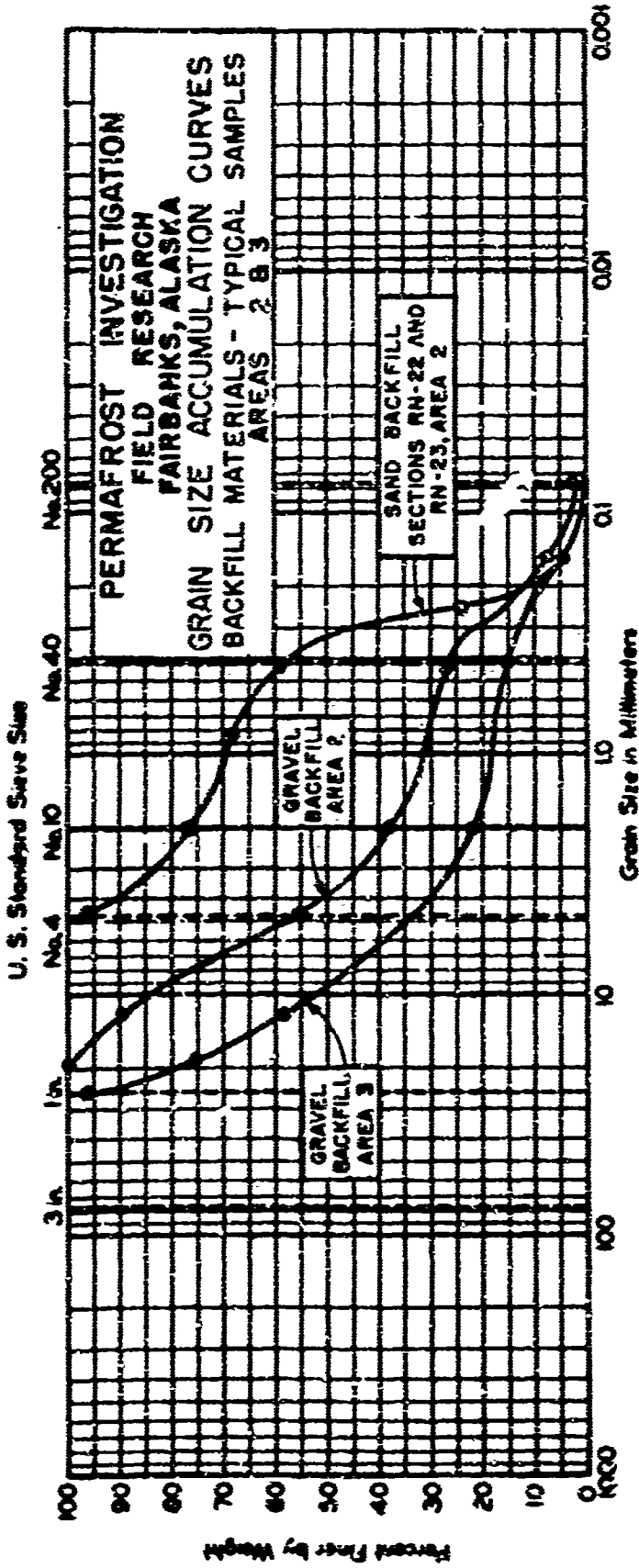

COBBLES	GRAVEL		SAND		SILT or CLAY
	Coarse	Medium	Fine	Coarse	

Number	Natural Moisture	LL	PL	PI	Classification	Remarks
Area 2	-	-	-	-	Sand	Nonplastic
Area 2	-	-	-	-	Gravel	"
Area 3	-	-	-	-	"	"

SOILS LABORATORY
PERMAFROST
LADD A.F.B., ALASKA

PROJECT Field Research
AREA 2 & 3 Backfill Material
LOCATION See Curve NO. 19. --
PLOTTED BY _____ CHECKED BY _____

SDS Form 305
7 NOV 49

MAY 1950

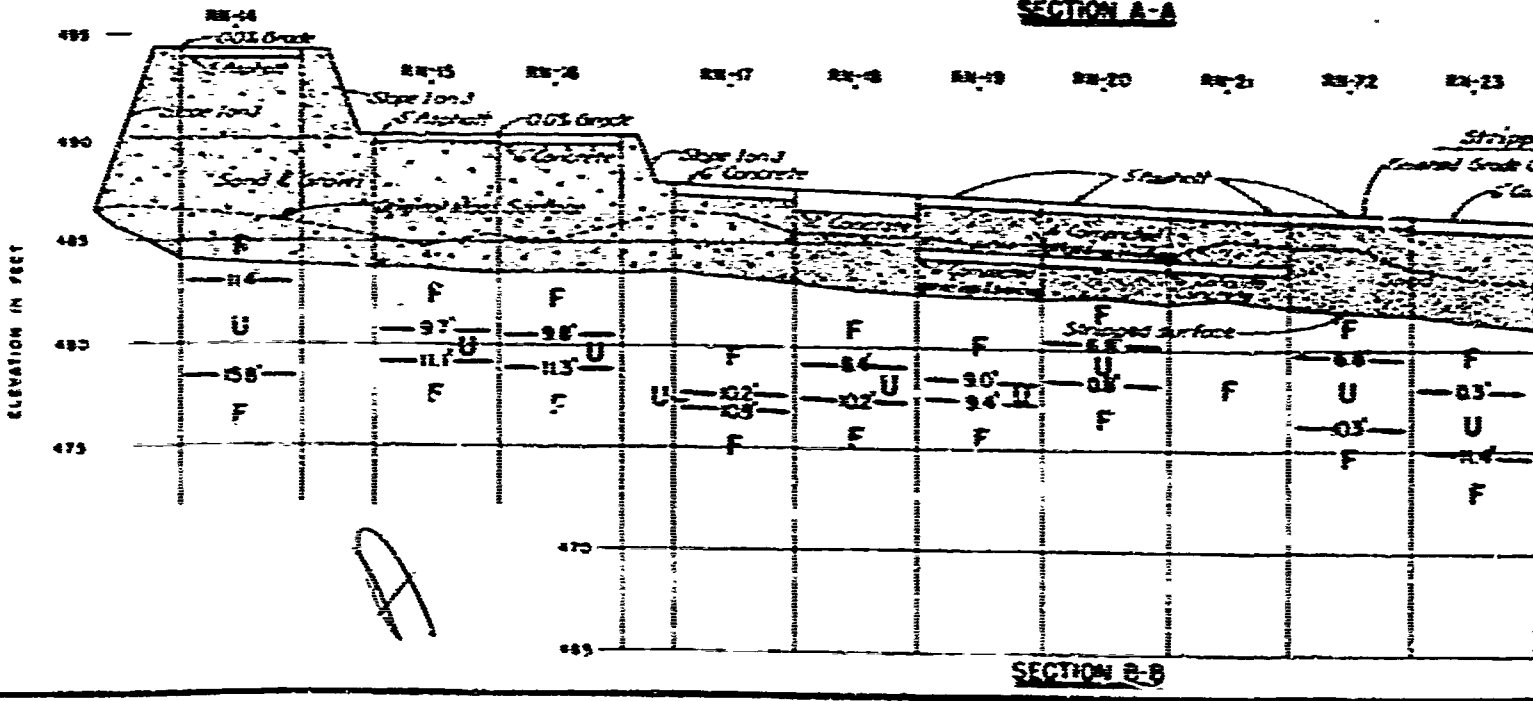
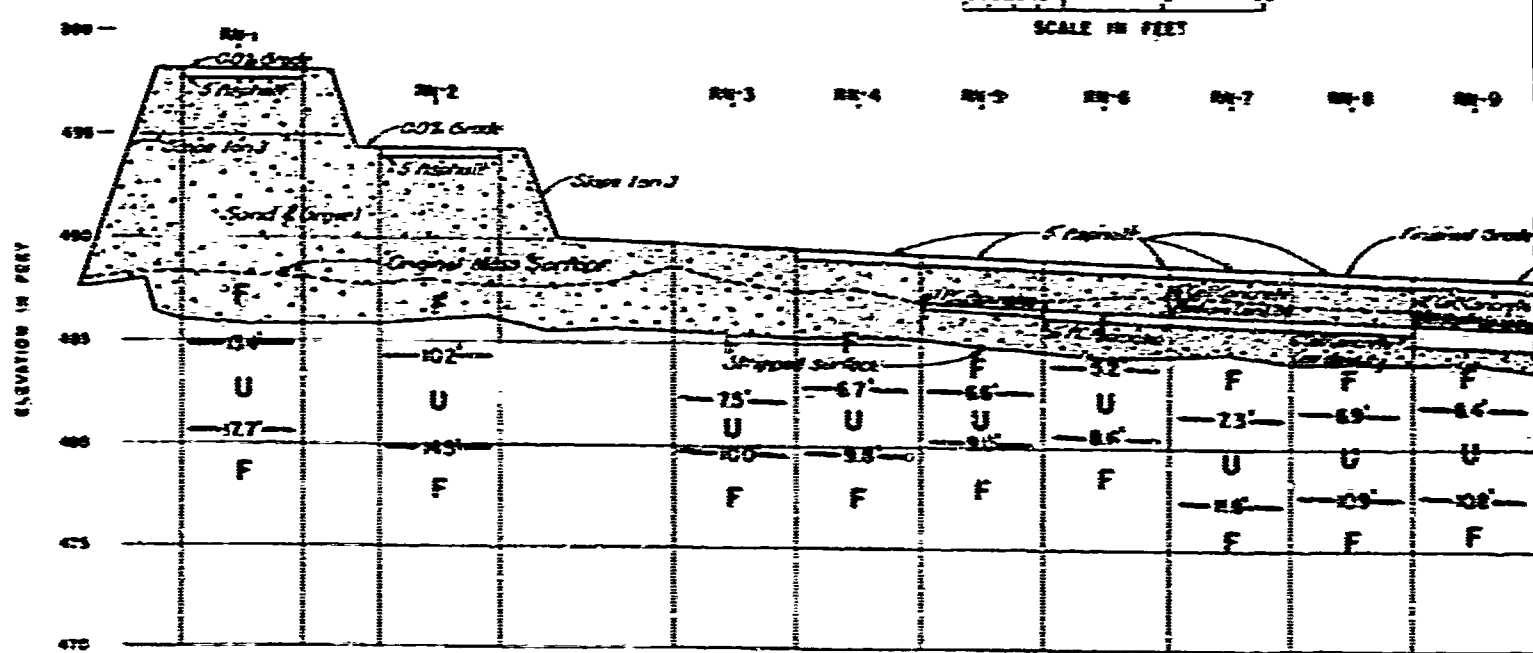
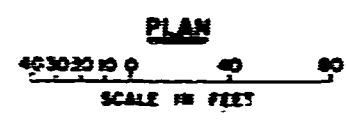
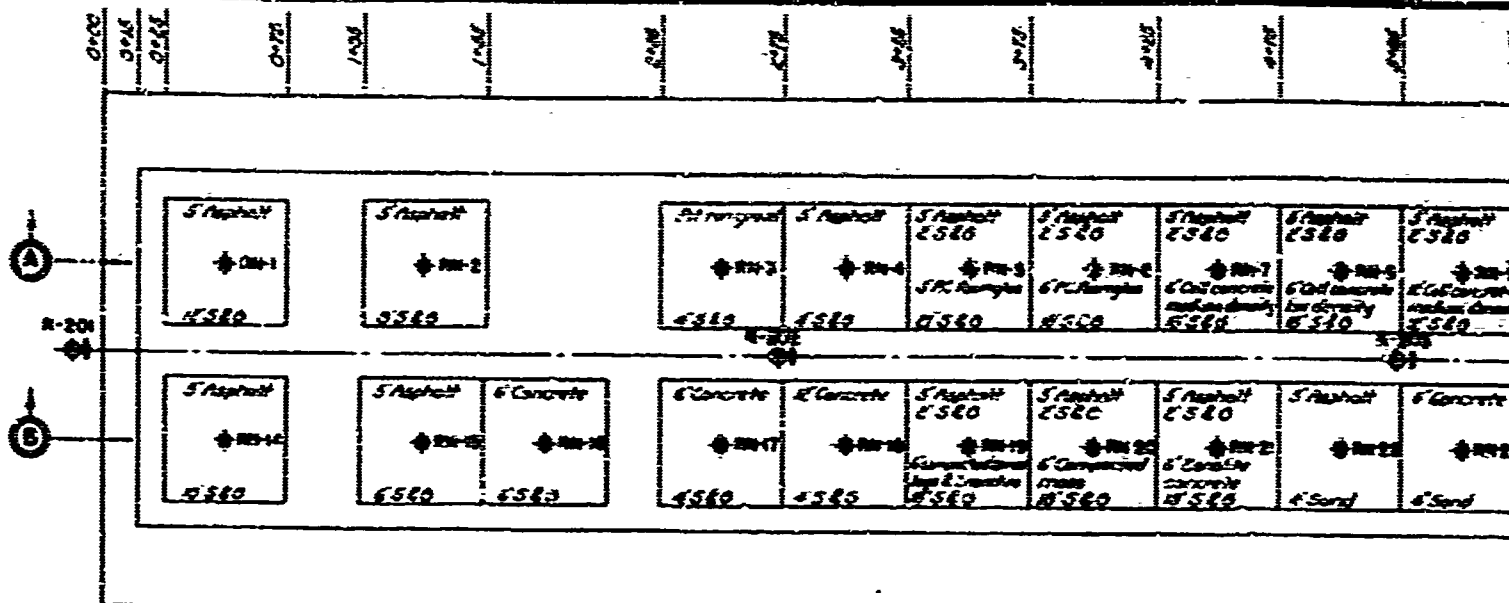

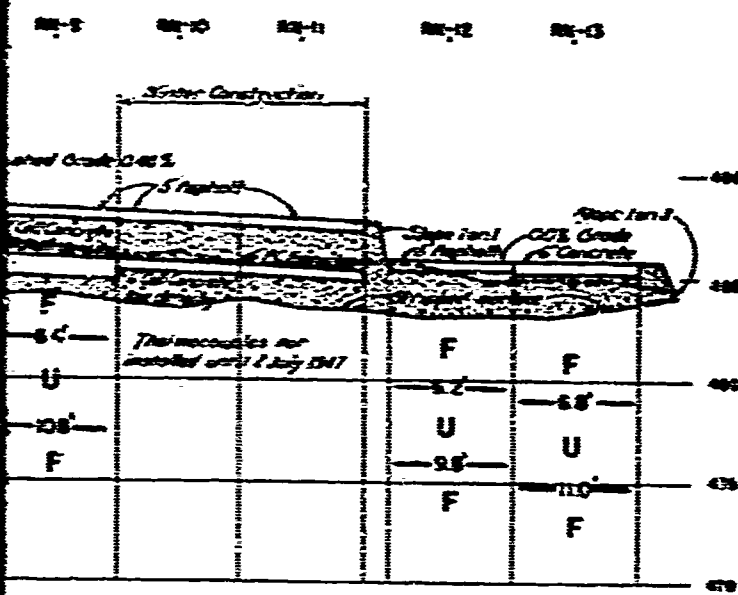
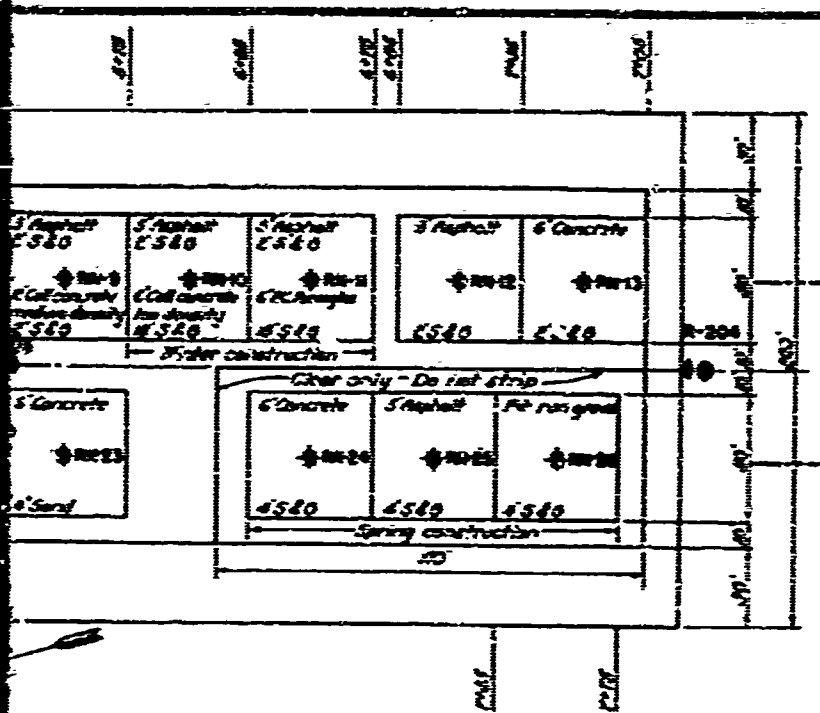

LEGEND

- ◆ 35 Core Spring (Ground temperature hole)
- ◆ 15 Churn drill boring (Ground temperature hole)
- ◆ Frost observation point.
- S25 Pit run sand and gravel.
- 88' Limit of frozen and unfrozen zones with depth below surface of section
- F Frozen Zone
- U Unfrozen Zone

Note:
At ground temperature holes P-201 and P-204 seasonal frost and permafrost have ranged

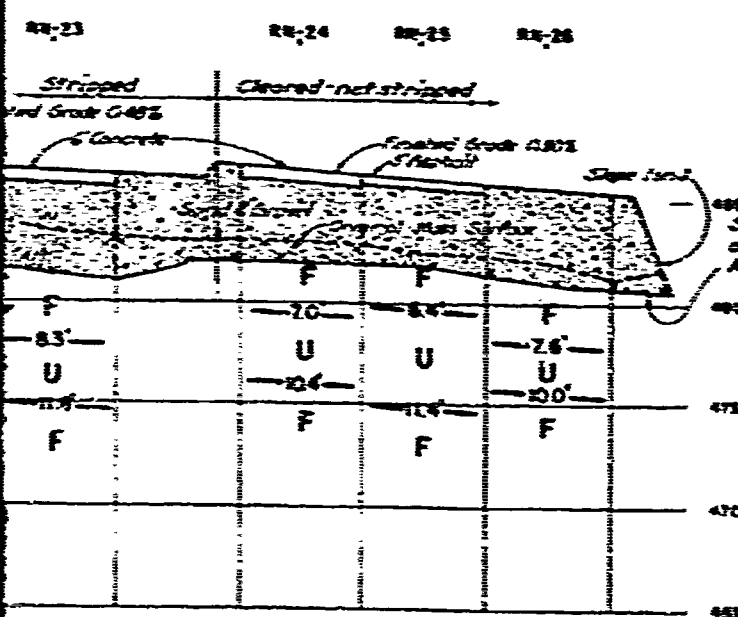

**PERMAFROST INVESTIGATION
FIELD RESEARCH
FAIRBANKS, ALASKA
AREA NO. 2
RUNWAY FOUNDATION STUDIES
FROZEN AND UNFROZEN ZONES
1 FEBRUARY 1947
SCALE AS SHOWN**

B

CORPS OF ENGINEERS, ST. PAUL, MINN.
DRAWN BY E.C.T. TRACED BY M.J.C. MAY 1947
CHECKED BY:

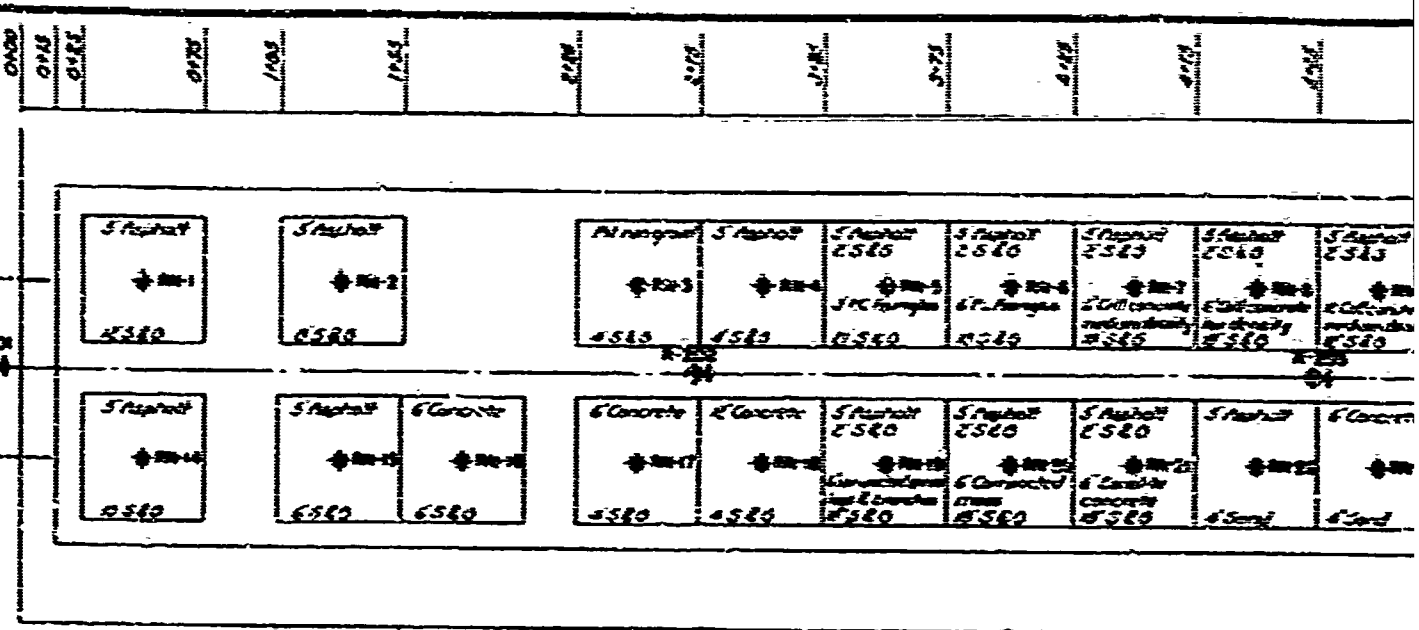

PLAN
 40 30 20 10 0 10 20 30 40
 SCALE IN FEET

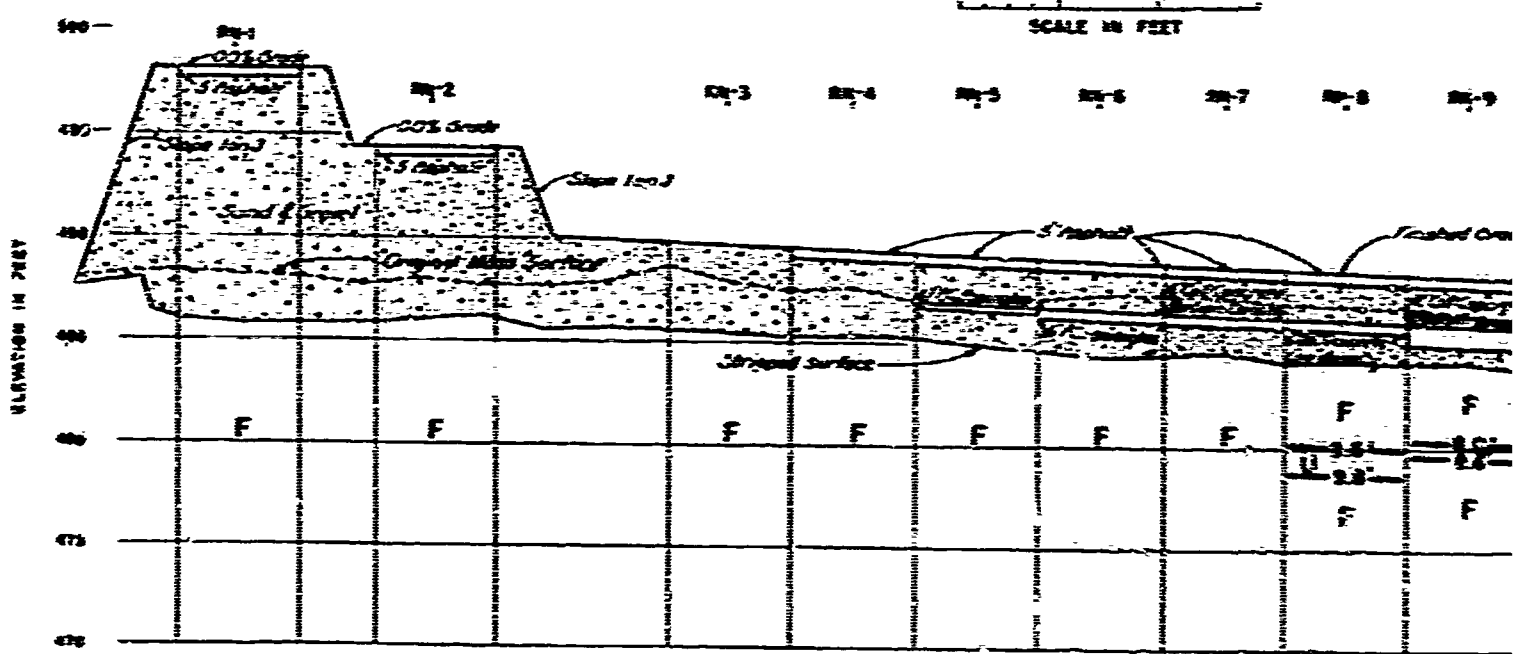

SECTION A-A

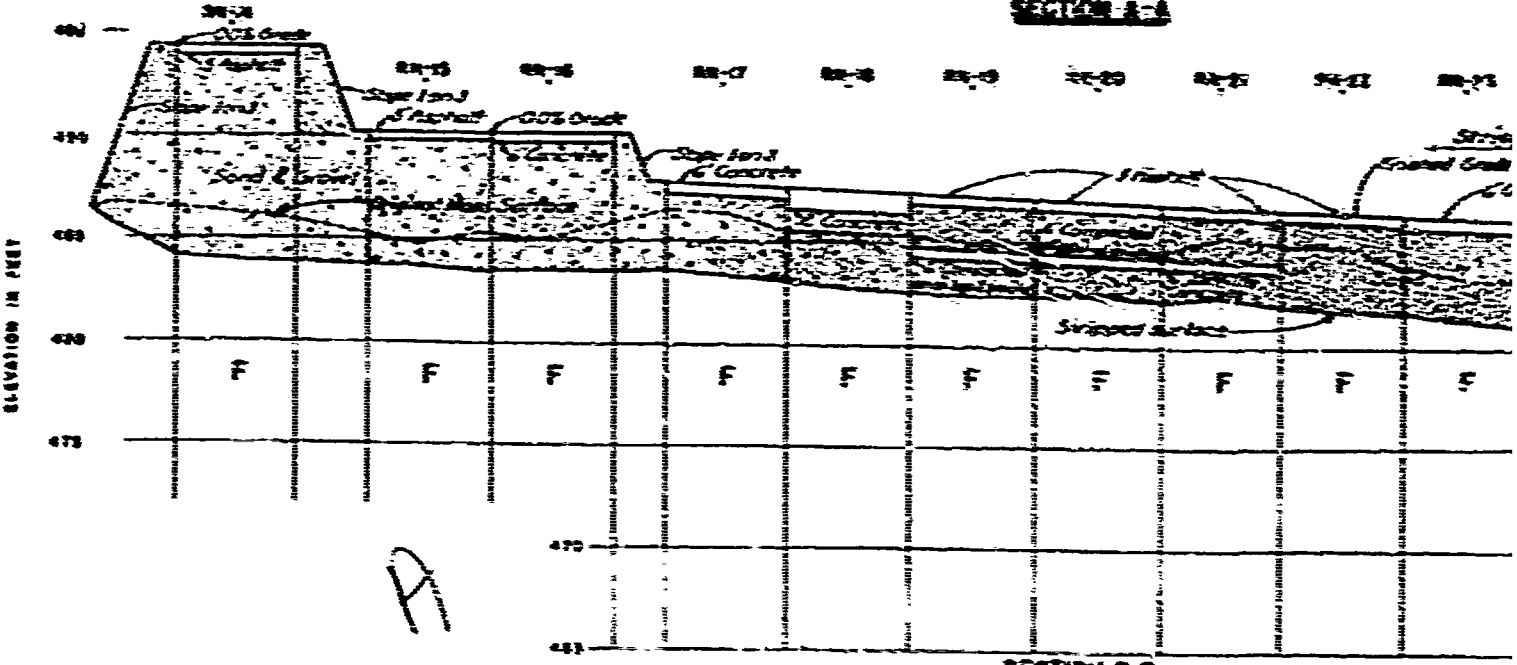

SECTION B-B

A

0+00	0+25	0+50	1+00	1+50	2+00	2+50	3+00	3+50	4+00	4+50	5+00											
3' Asphalt RN-1 15'580	3' Asphalt RN-2 15'580	4' Run gravel RN-3 15'580	3' Asphalt RN-4 15'580	3' Asphalt 2.5% J.P.C. Paving RN-5 15'580	3' Asphalt 2.5% P.C. Paving RN-6 15'580	3' Asphalt 2.5% 6" Cell concrete medium density RN-7 15'580	3' Asphalt 2.5% 6" Cell concrete low density RN-8 15'580	3' Asphalt 2.5% RN-9 15'580	3' Asphalt RN-10 15'580	6' Concrete RN-11 15'580	12' Concrete RN-12 15'580	3' Asphalt 2.5% RN-13 15'580	3' Asphalt 2.5% RN-14 15'580	6' Concrete RN-15 15'580	6' Concrete RN-16 15'580	3' Asphalt 2.5% RN-17 15'580	3' Asphalt 2.5% RN-18 15'580	3' Asphalt 2.5% RN-19 15'580	3' Asphalt 2.5% RN-20 15'580	6' Concrete RN-21 15'580	3' Asphalt RN-22 15'580	6' Concrete RN-23 15'580

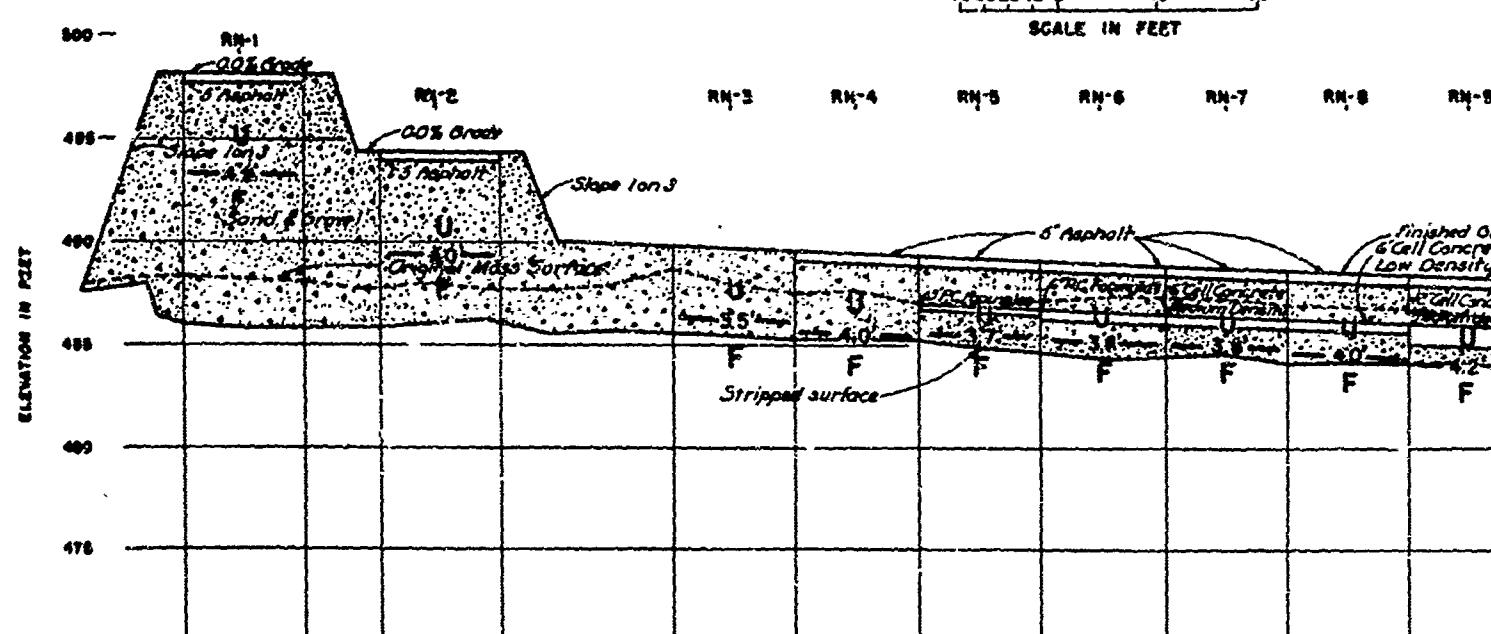
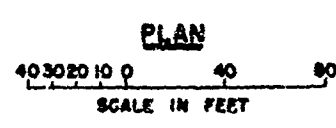
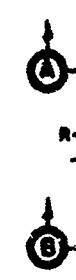

SECTION A-A

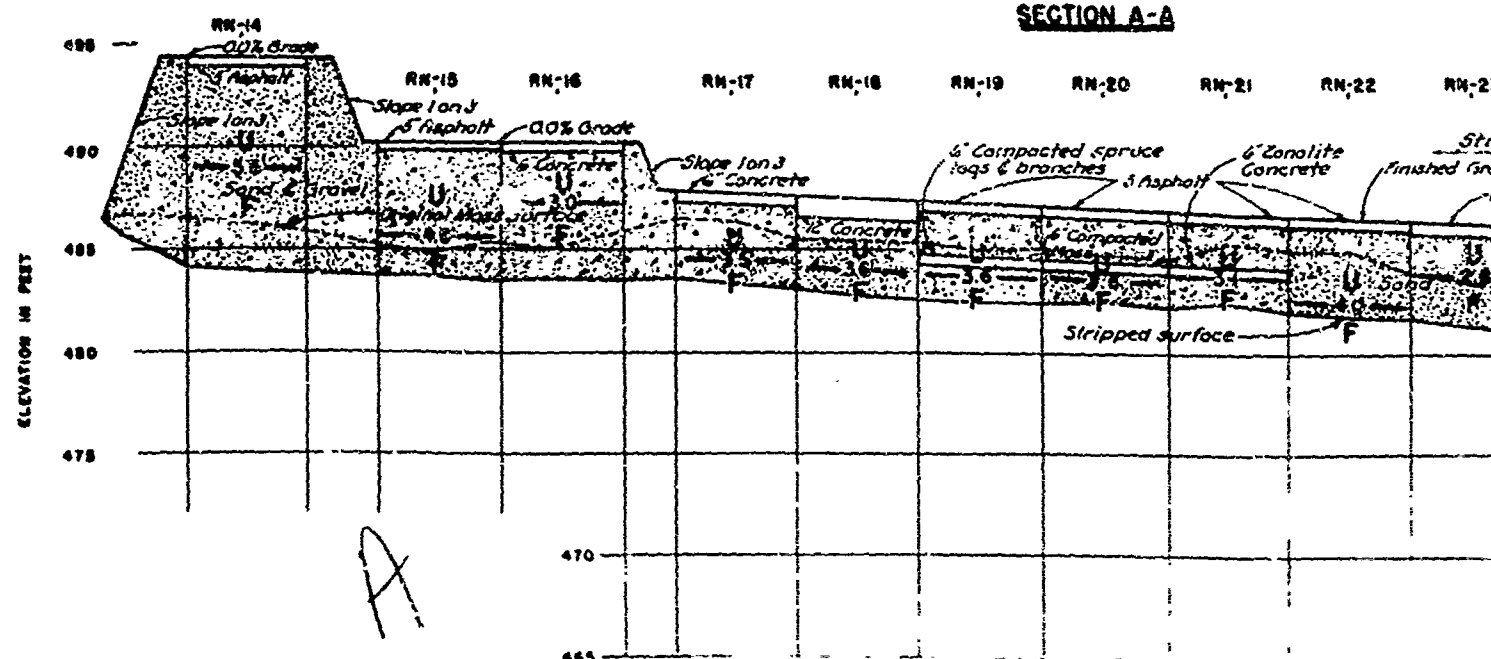

SECTION B-B

A

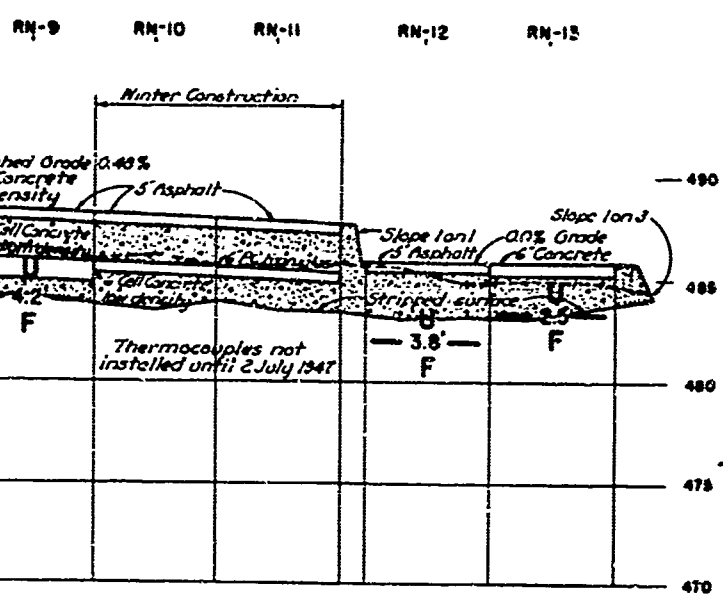
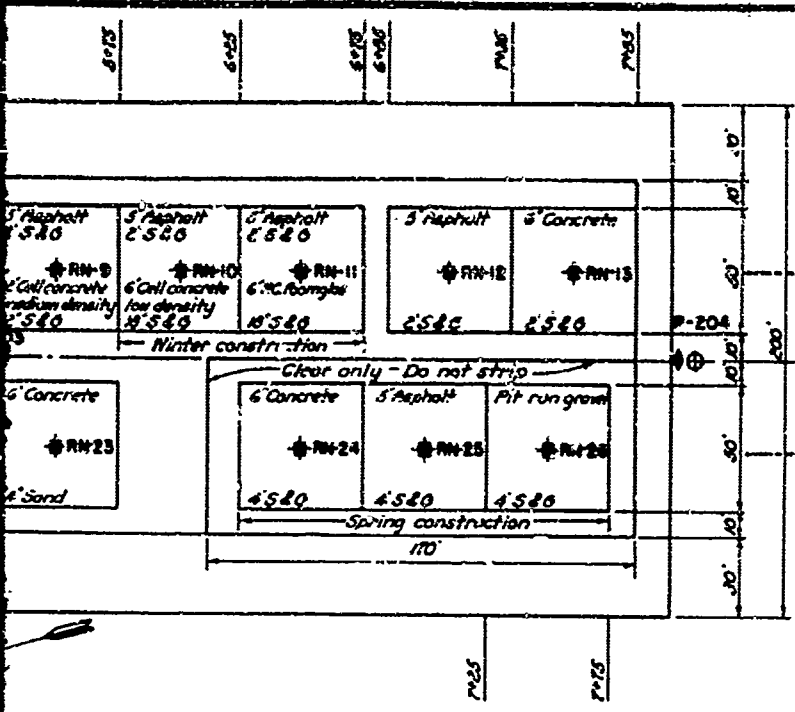

LEGEND

- ⊕ 30' Core boring (Ground temperature hole)
- ⊕ 15' Churn drill boring (Ground temperature hole)
- ◆ Frost observation point.
- S&G Pit run sand and gravel.
- 3.8'- Limit of frozen and unfrozen zones with depth below surface of section.
- F Frozen Zone
- U Unfrozen Zone

Note:
 At ground temperature hole R 27, no observations possible due to flooding of junction box.
 At ground temperature hole R 204 temperature at surface was 0°C, no penetration of thaw recorded.

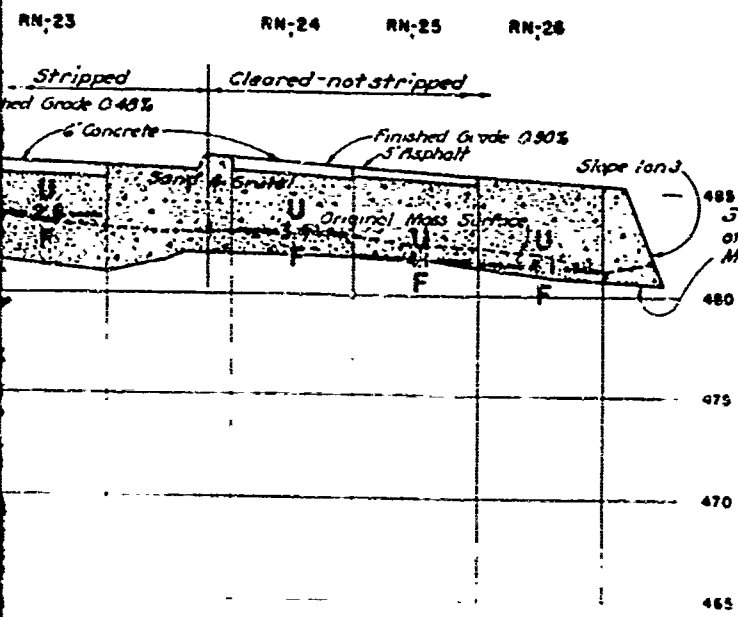

**PERMAFROST INVESTIGATION
 FIELD RESEARCH
 FAIRBANKS, ALASKA
 AREA NO. 2
 RUNWAY FOUNDATION STUDIES
 FROZEN AND UNFROZEN ZONES
 1 MAY 1947
 SCALE AS SHOWN**

CORPS OF ENGINEERS, ST PAUL, MINN
 DRAWN BY E C T TRACED BY E C T
 MAY 1950
 CHECKED BY

B

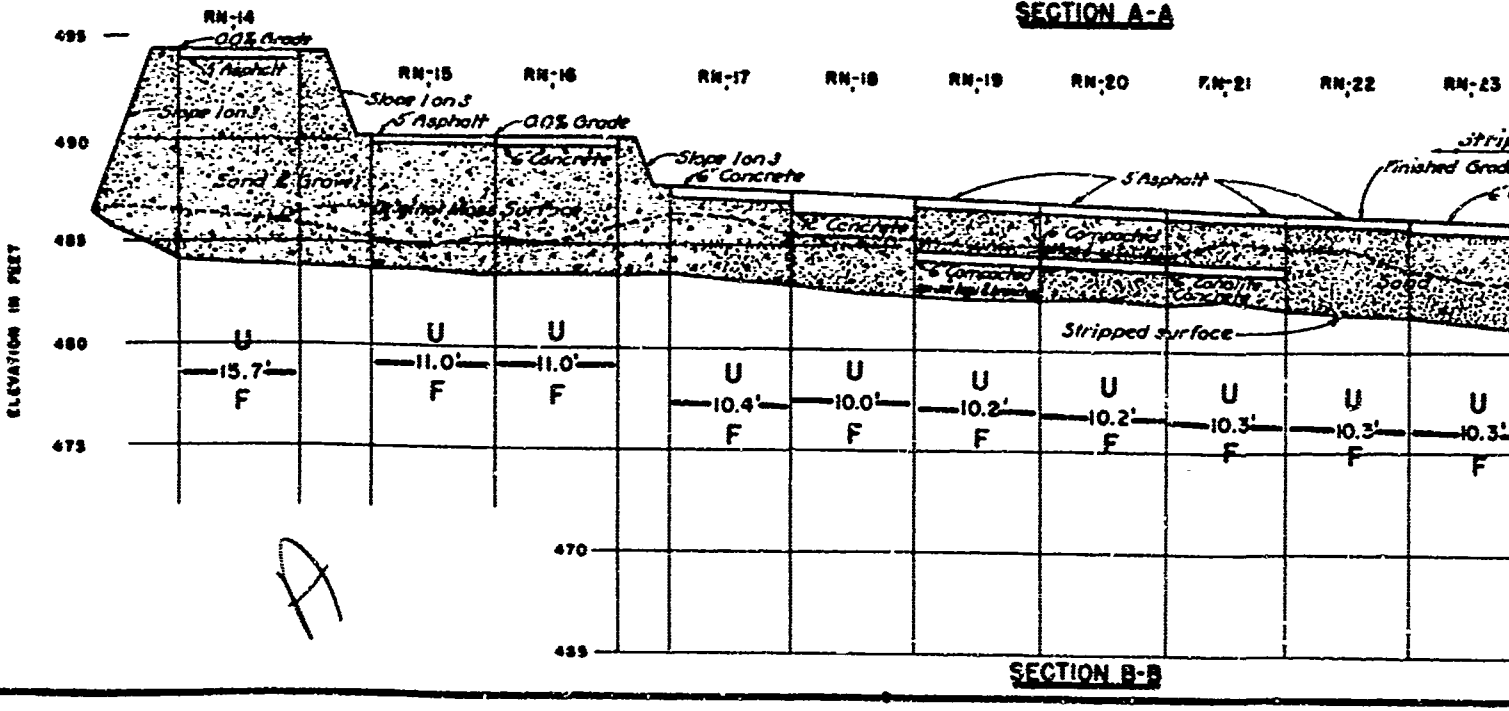
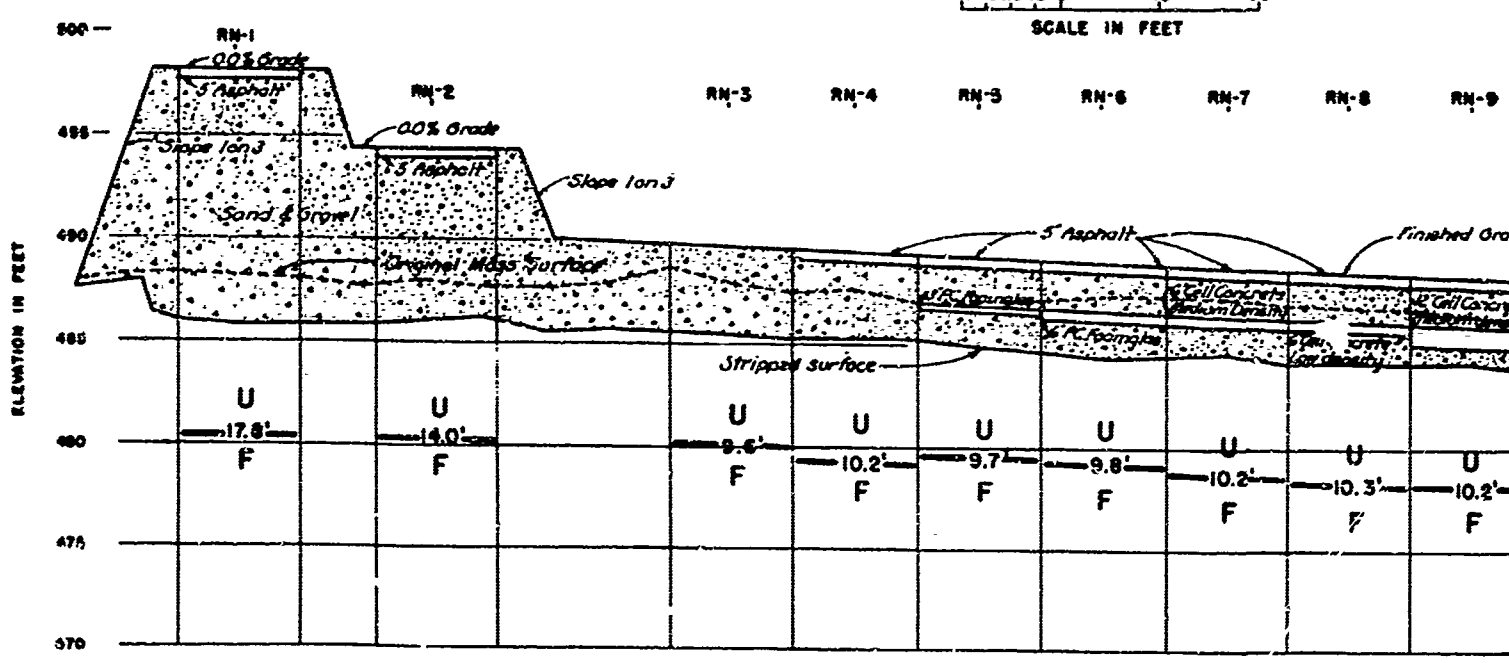
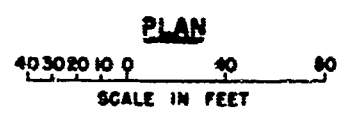
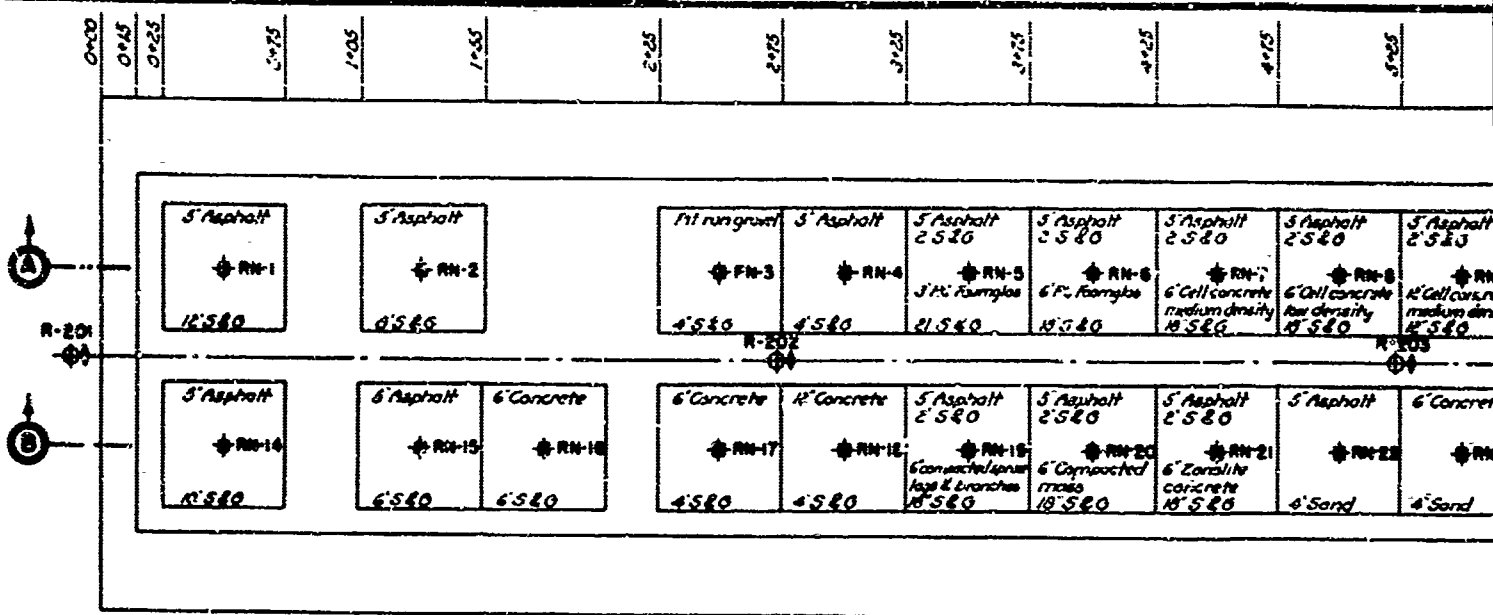

A

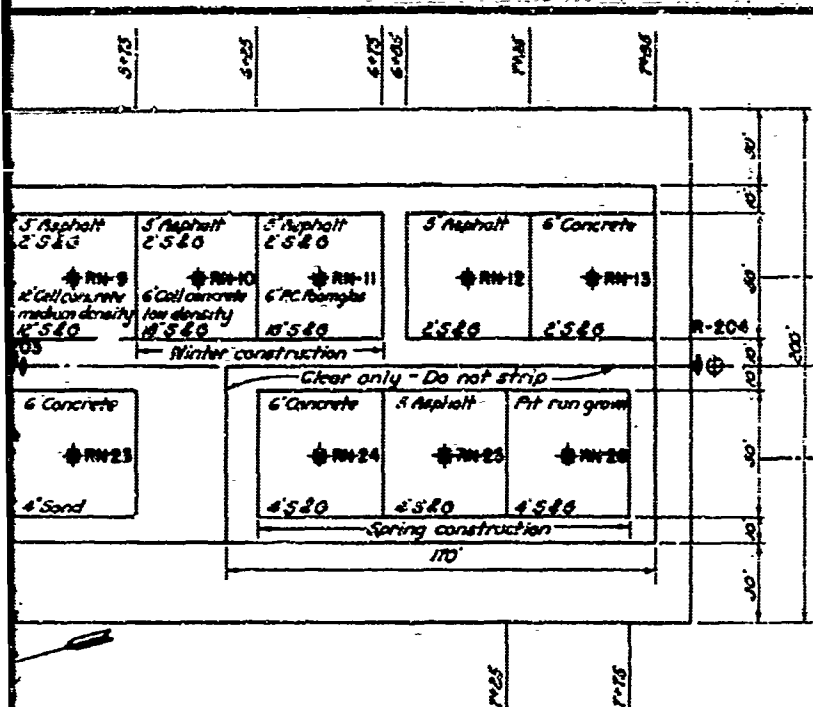

RN-9 RN-10 RN-11 RN-12 RN-13

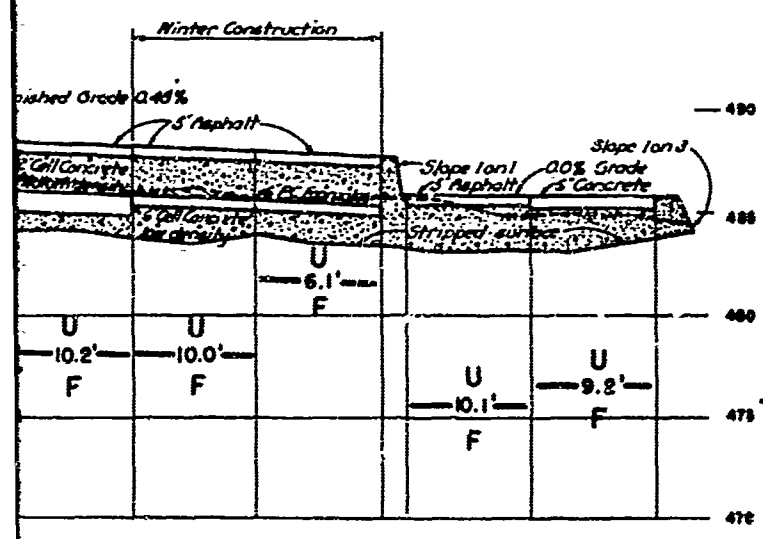

LEGEND

- ⊕ 30' Core boring (Ground temperature hole)
- ⊕ 15' Churn drill boring (Ground temperature hole)
- ◆ Frost observation point.
- S&G Pit run sand and gravel.
- 92- Limit of frozen and unfrozen zones with depth below surface of section.
- F Frozen Zone
- U Unfrozen Zone

Note:
 At ground temperature hole R-201, depth to permafrost=4.6'.
 At ground temperature hole R-204, depth to permafrost=6.0'.

RN-23 RN-24 RN-25 RN-26

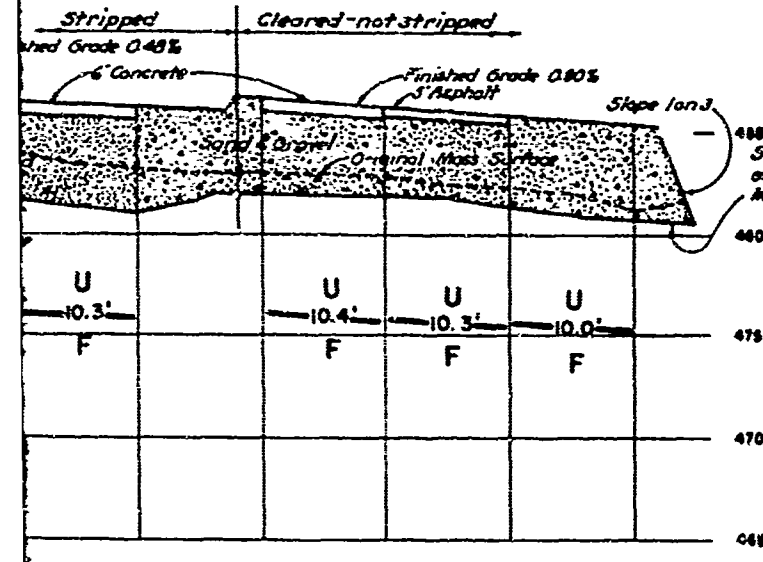

PERMAFROST INVESTIGATION
FIELD RESEARCH
FAIRBANKS, ALASKA
AREA NO. 2
RUNWAY FOUNDATION STUDIES
FROZEN AND UNFROZEN ZONES
1 OCT. 1947
 SCALE AS SHOWN

B

CORPS OF ENGINEERS, ST. PAUL, MINN.
 DRAWN BY: E.C.T. TRACED BY: M.J.B. MAY 1990
 CHECKED BY:

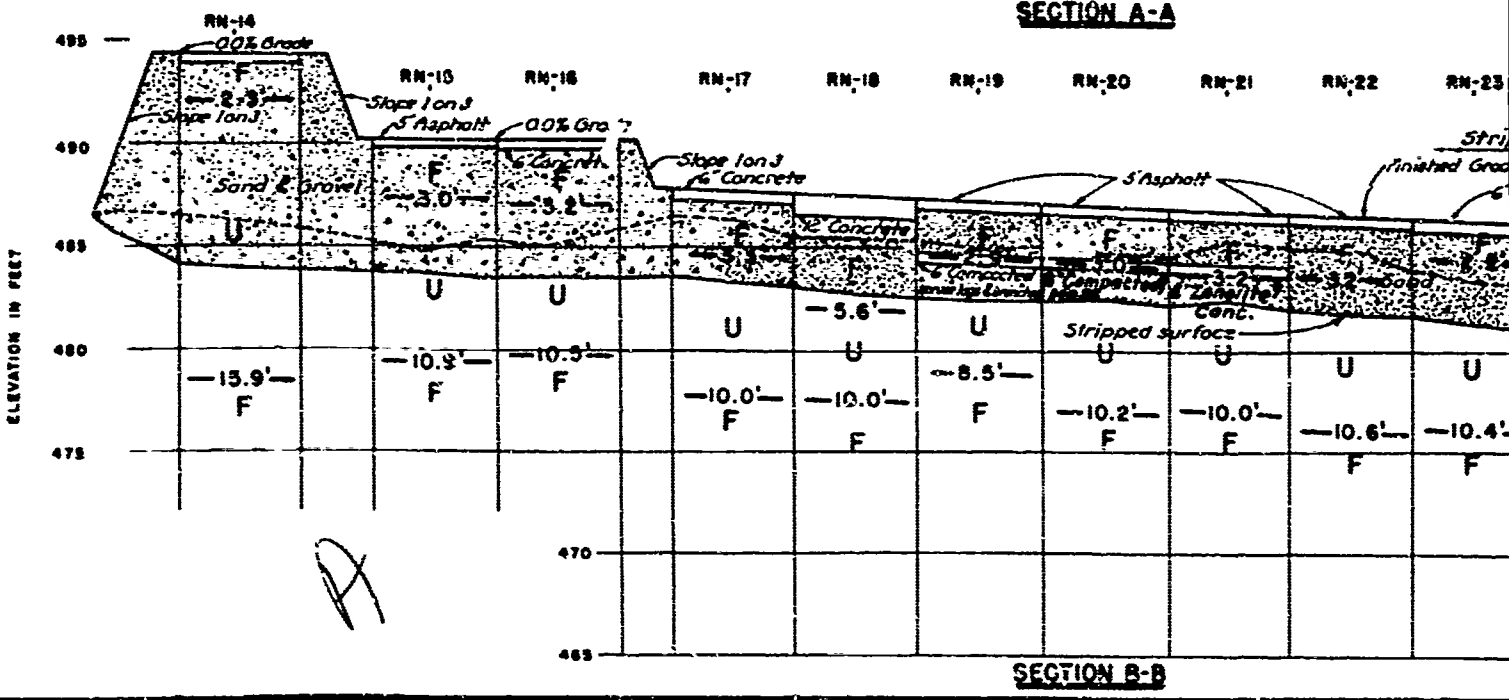
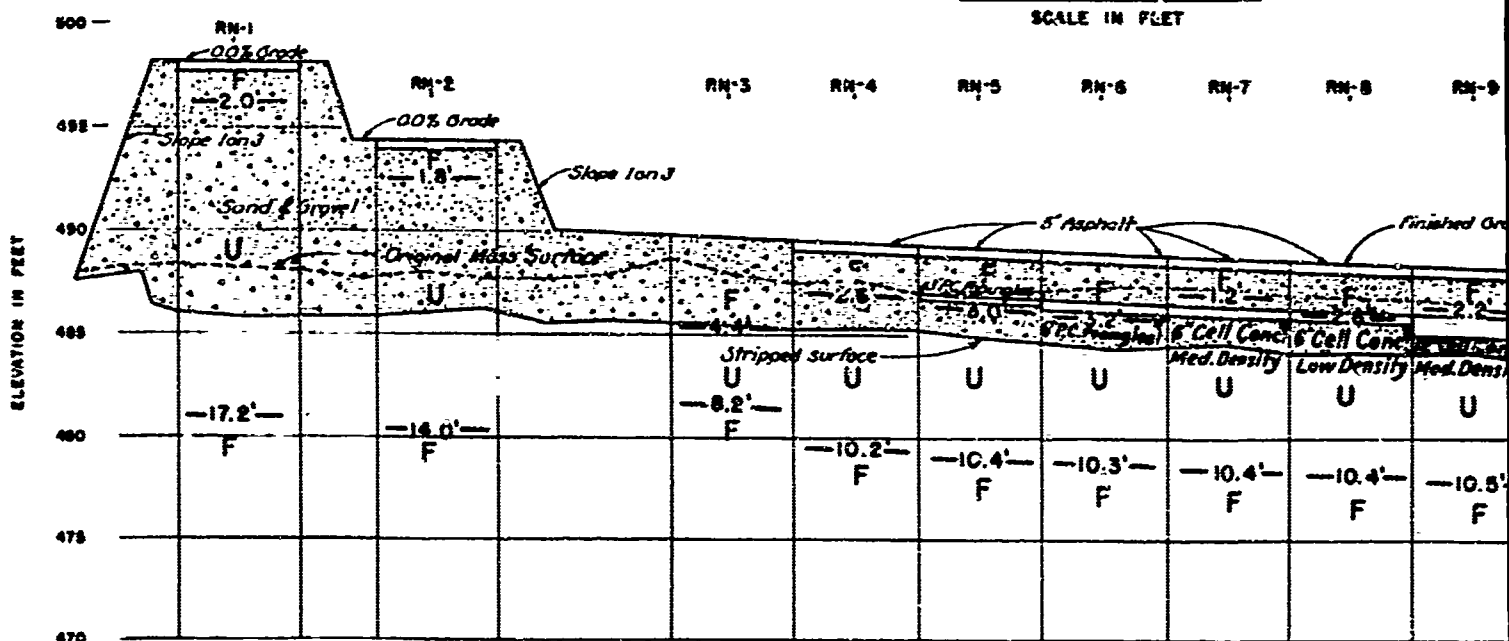
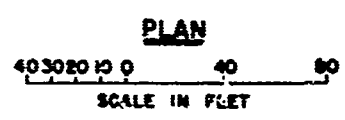
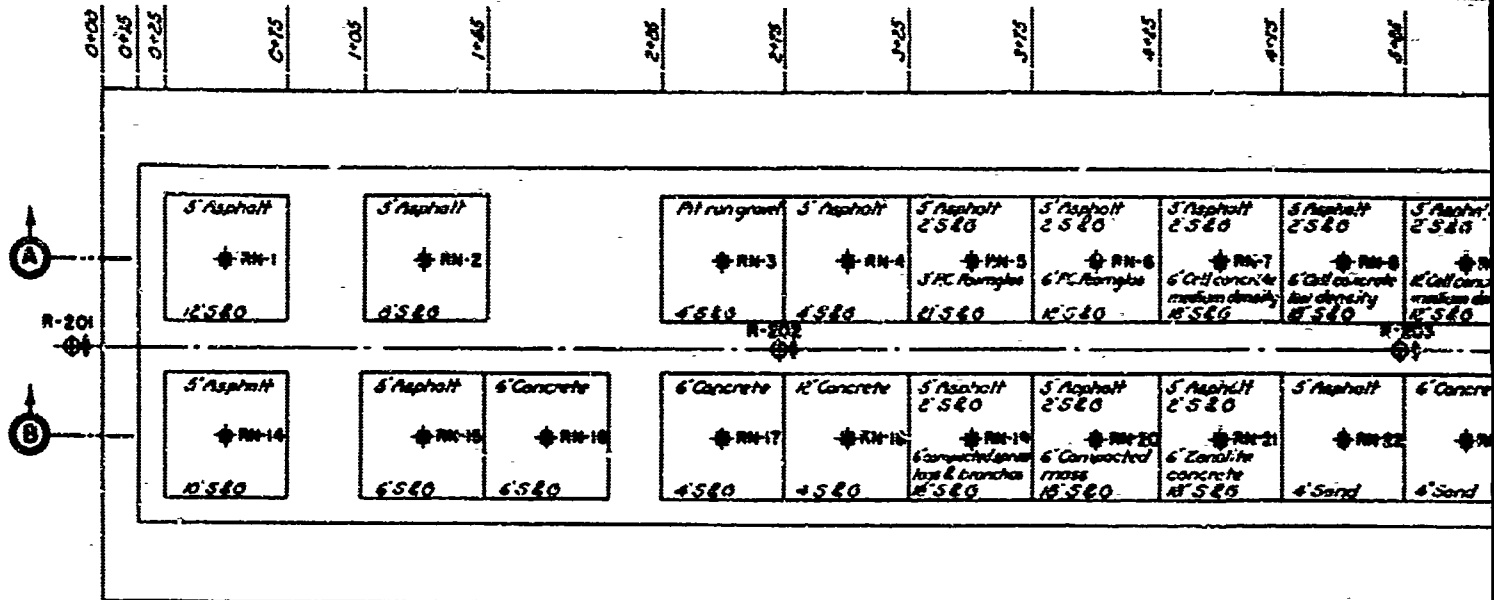

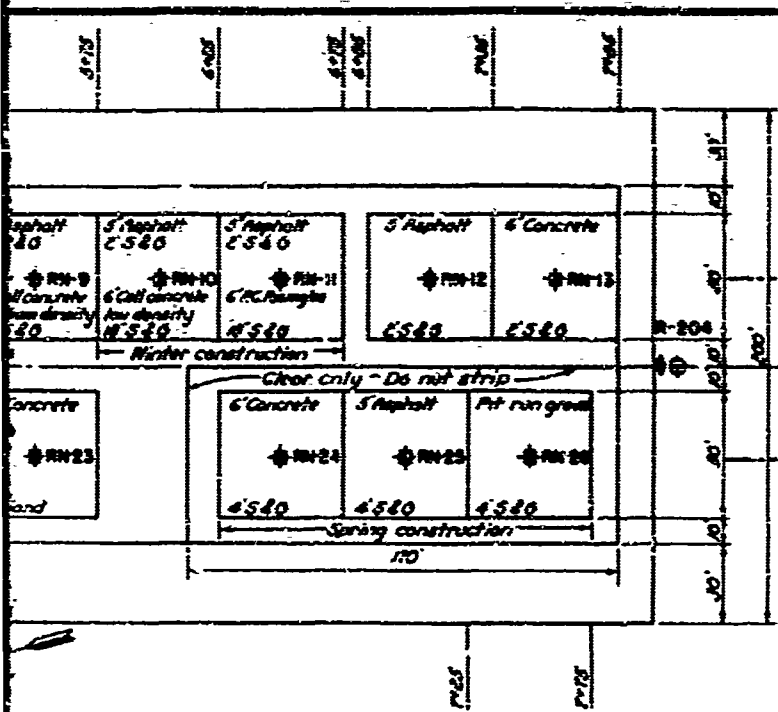

RN-9 RN-10 RN-11 RN-12 RN-13

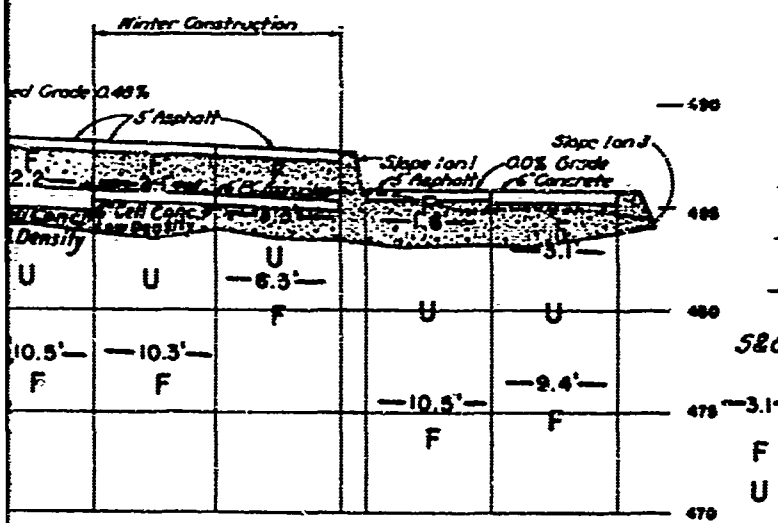

LEGEND

- ⊕ 30' Core boring (Ground temperature hole)
- ⊕ 15' Churn drill boring (Ground temperature hole)
- ◆ Frost observation point.
- 5&6 Pit run sand and gravel.
- 3.1— Limit of frozen and unfrozen zones with depth below surface of section.
- F Frozen Zone
- U Unfrozen Zone

Note:

1. At ground temperature hole R-201 seasonal frost and permafrost have merged.
2. At ground temperature hole R-204 depth of seasonal frost = 11'. Depth to permafrost = 5.0'.

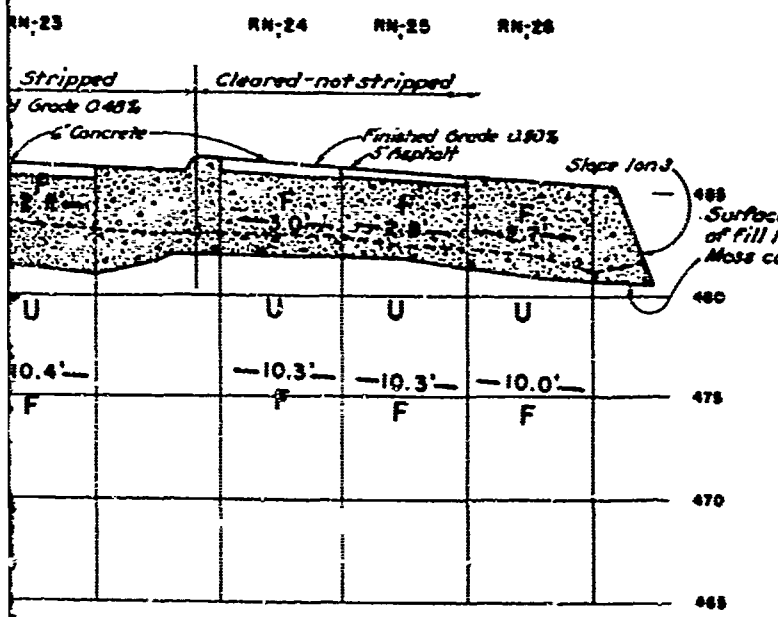

**PERMAFROST INVESTIGATION
FIELD RESEARCH
FAIRBANKS, ALASKA
AREA NO. 2
RUNWAY FOUNDATION STUDIES
FROZEN AND UNFROZEN ZONES
31 OCT 1947
SCALE AS SHOWN**

CORPS OF ENGINEERS, ST. PAUL, MINN. MAY 1936
DRAWN BY E.C.T. TRACES BY W.O.S. CHECKED BY:

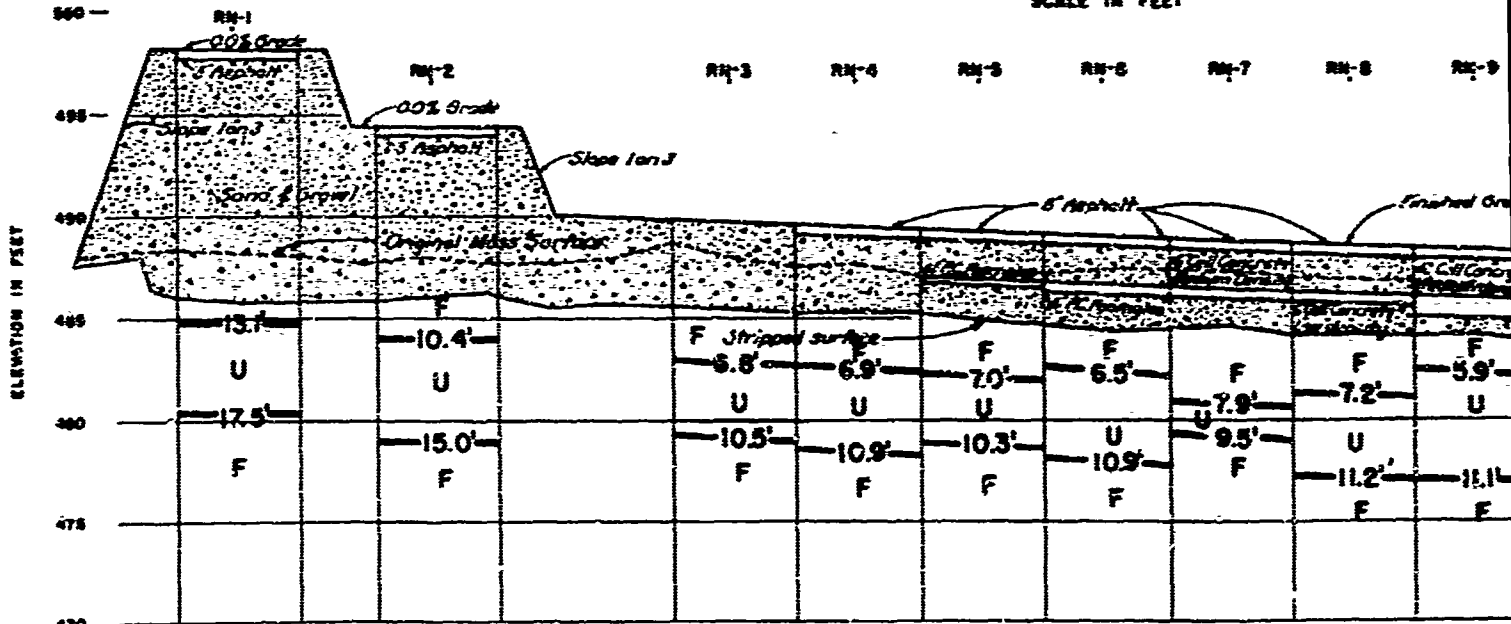
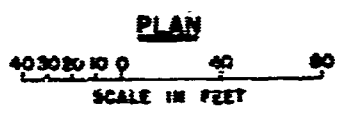
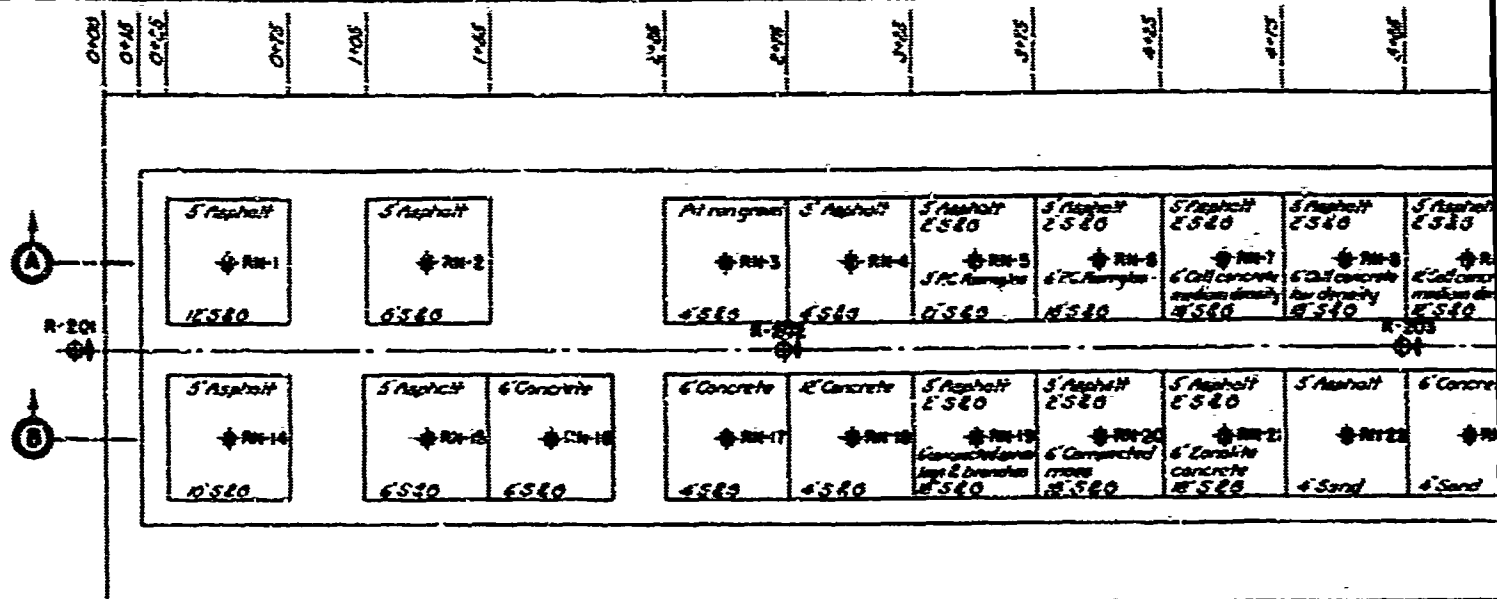

SECTION A-A

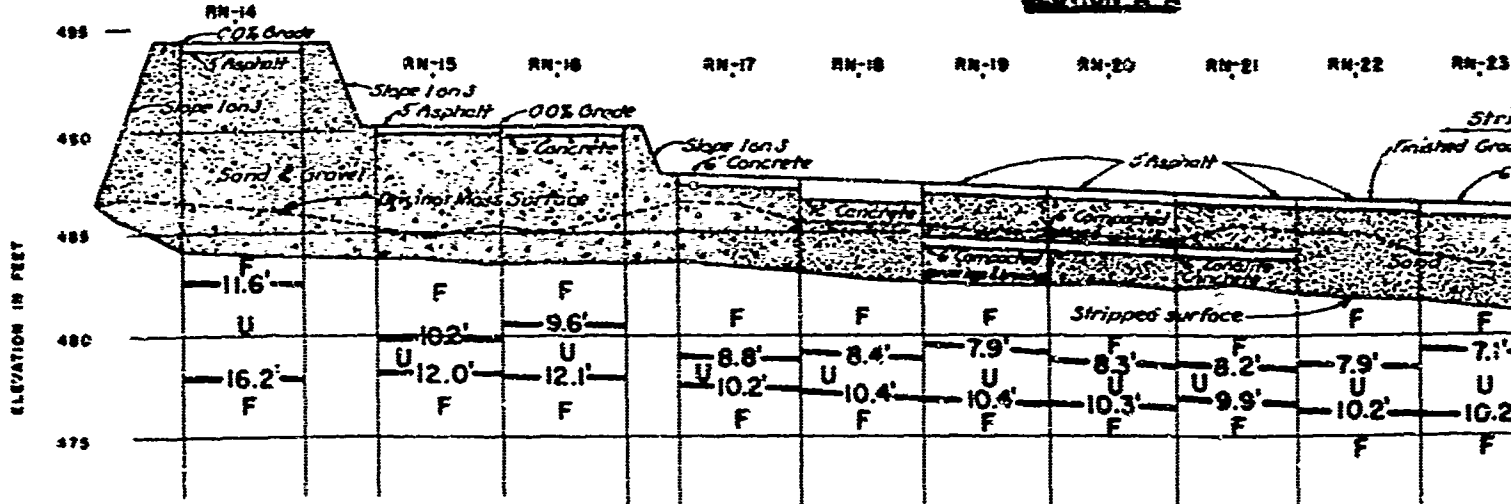

SECTION B-B

19

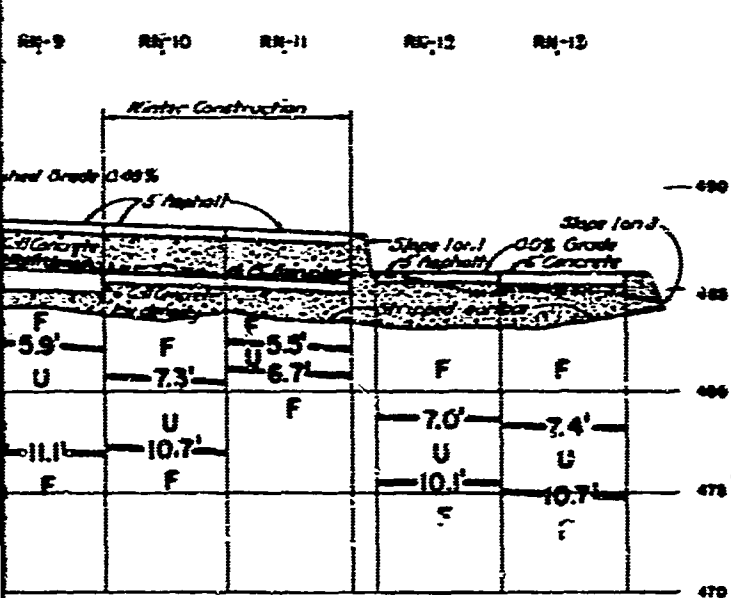
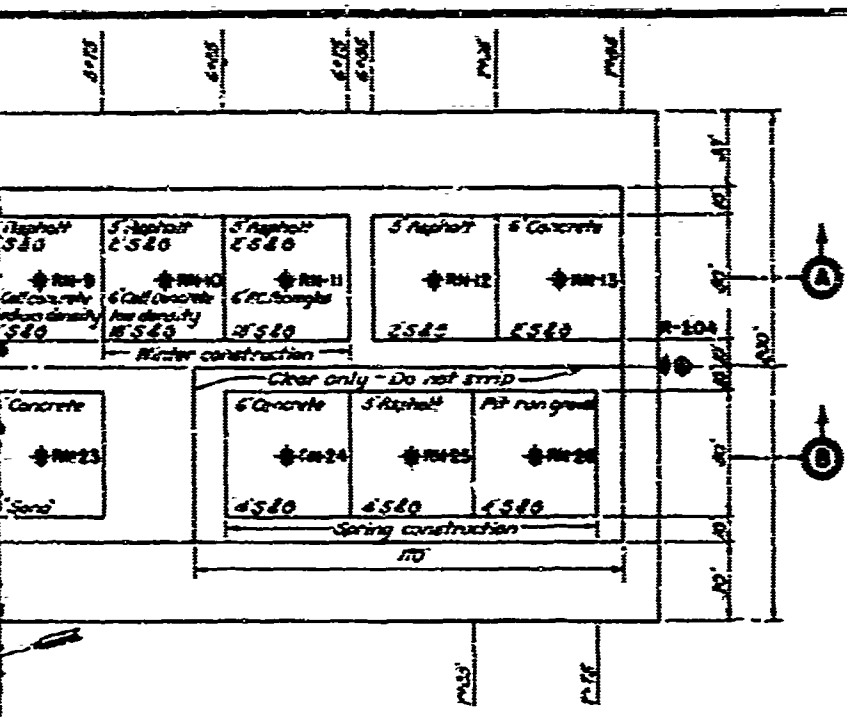

LEGEND

- ◆ 30' Core boring (Ground temperature hole)
- ◆ 15' Churn drill boring (Ground temperature hole)
- ◆ Frost observation point.
- S&G Pit run sand and gravel.
- - - Limit of frozen and unfrozen zones with depth below surface of section.
- F Frozen zone.
- U Unfrozen zone.

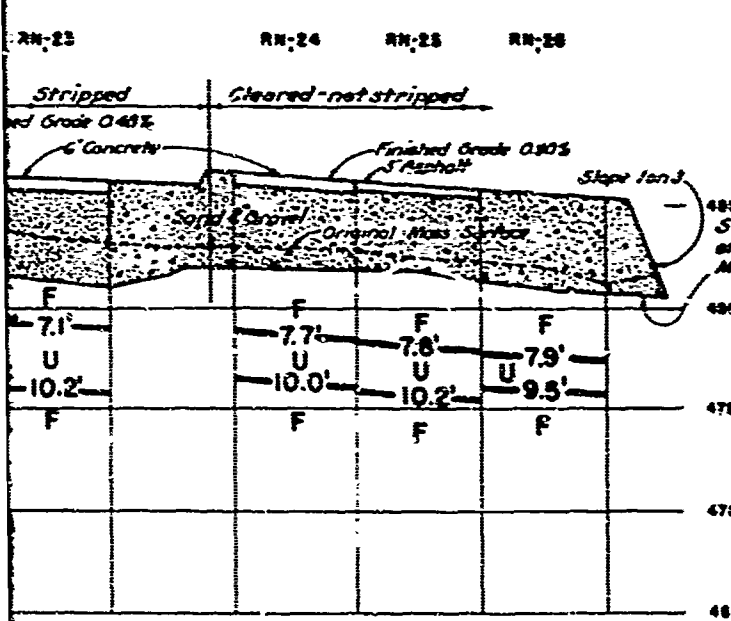

Note:
 At ground temperature hole R-201, depth to permafrost = 4.6'.
 At ground temperature hole R-204, depth to permafrost = 6.0'.

PERMAFROST INVESTIGATION
FIELD RESEARCH
FAIRBANKS, ALASKA
AREA NO. 2
RUNWAY FOUNDATION STUDIES
FROZEN AND UNFROZEN ZONES
1 FEBRUARY 1948
 SCALE AS SHOWN

B

CORPS OF ENGINEERS, ST. PAUL, MINN. MAY 1948
 DRAWN BY: E.C.T. TRACED BY: M.J.S. CHECKED BY:

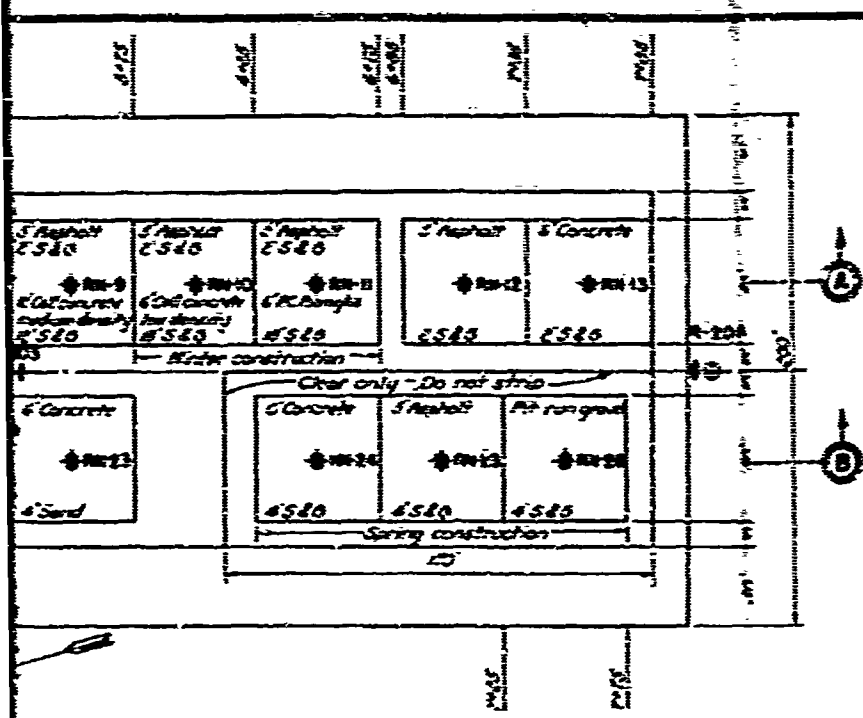

RR-9 RR-10 RR-11 RR-12 RR-13

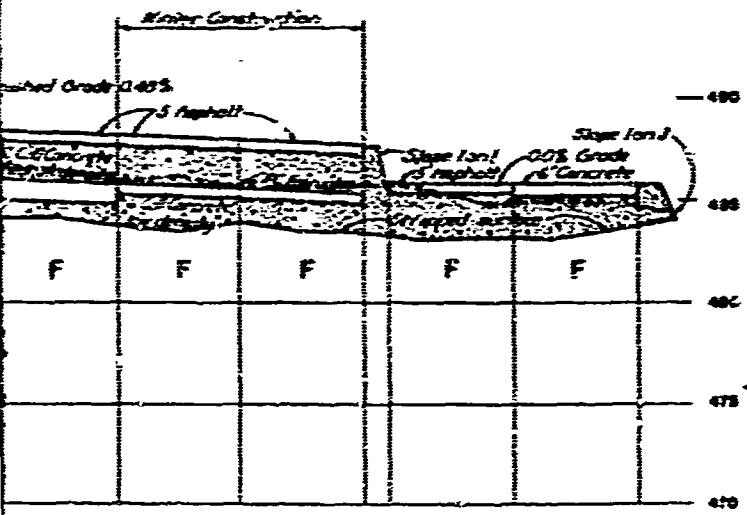

LEGEND

- ◆ 30' Core boring (Ground temperature hole)
- 15' Churn drill boring (Ground temperature hole)
- Frost observation point.
- S&G Pit run sand and gravel.
- 92- Limit of frozen and unfrozen zones with depth below surface of section.
- F Frozen zone.
- U Unfrozen zone.

RR-25 RR-24 RR-23 RR-26

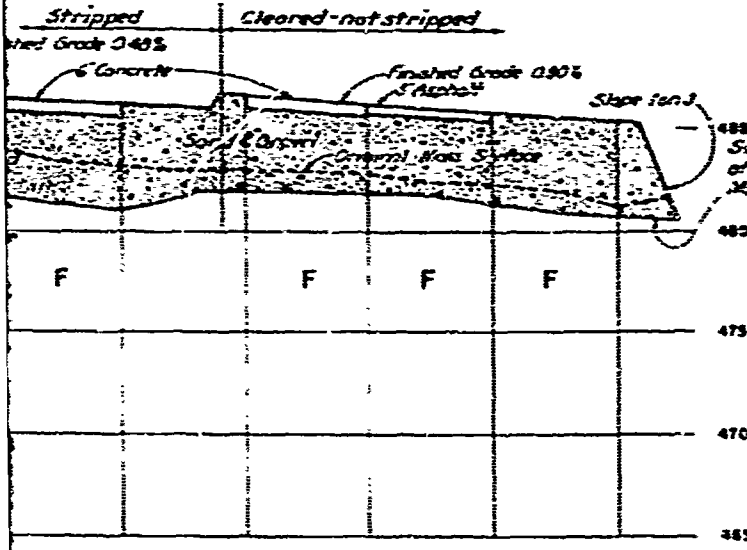

Note:

fit ground temperature hole R-201, depth to permafrost - 4.6'.
fit ground temperature hole R-204, depth to permafrost - 6.0'.

PERMAFROST INVESTIGATION
FIELD RESEARCH
FAIRBANKS, ALASKA
AREA NO. 2
RUNWAY FOUNDATION STUDIES
FROZEN AND UNFROZEN ZONES
1 APRIL 1948
 SCALE AS SHOWN

B

CORPS OF ENGINEERS, ST. PAUL, MINN.
 DRAWN BY E.C.T. TRACED BY W.J.E. MAY 1950
 CHECKED BY

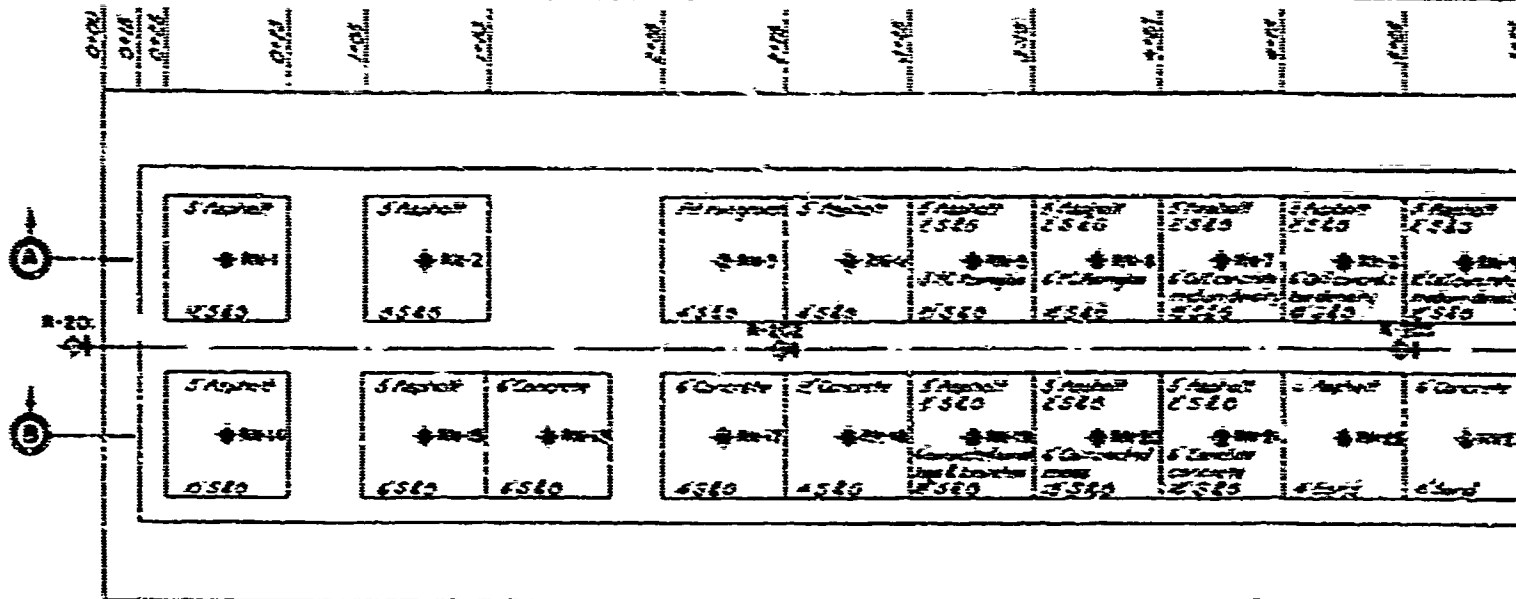

PLAN
SCALE IN FEET

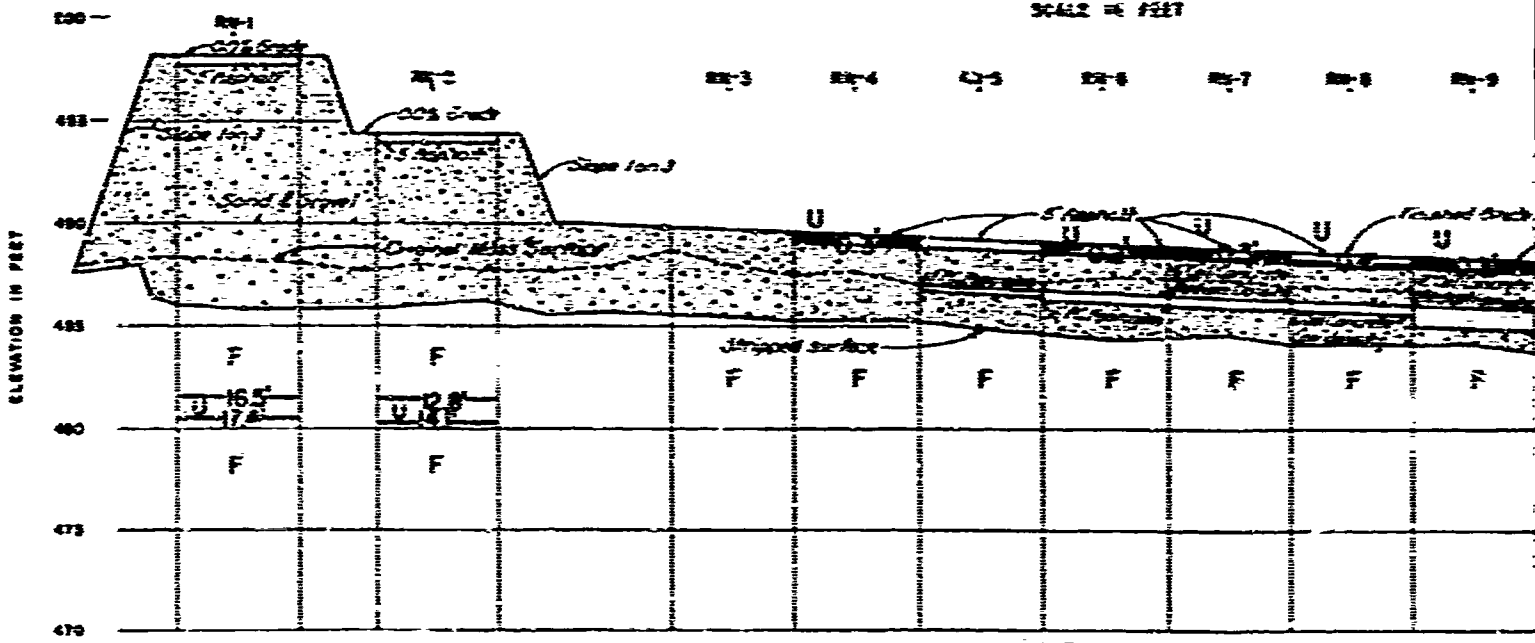

SECTION A-A

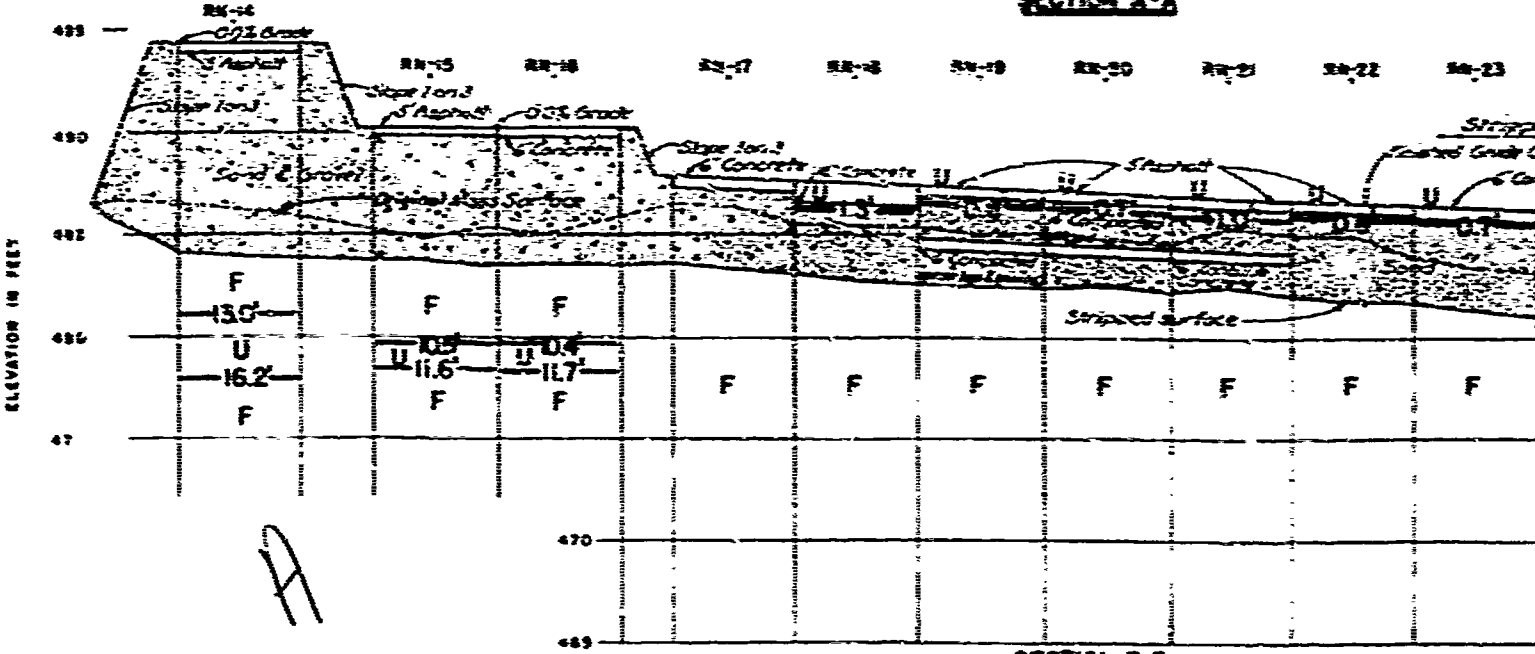

SECTION B-B

A

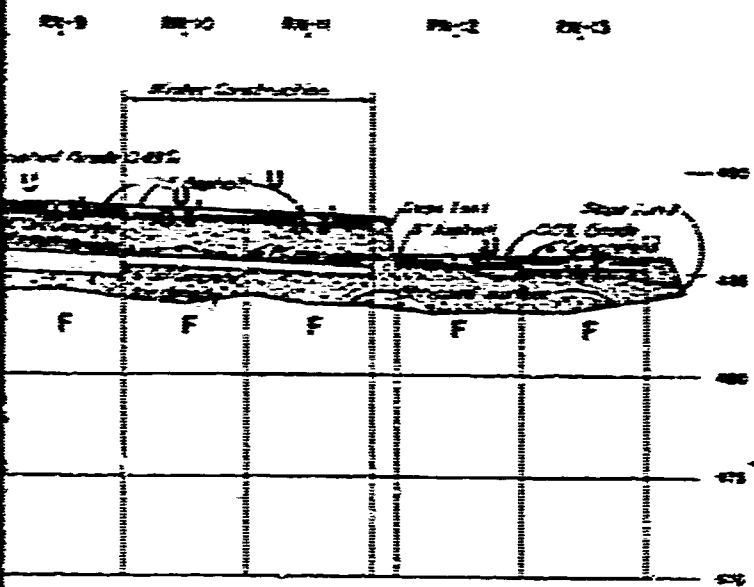
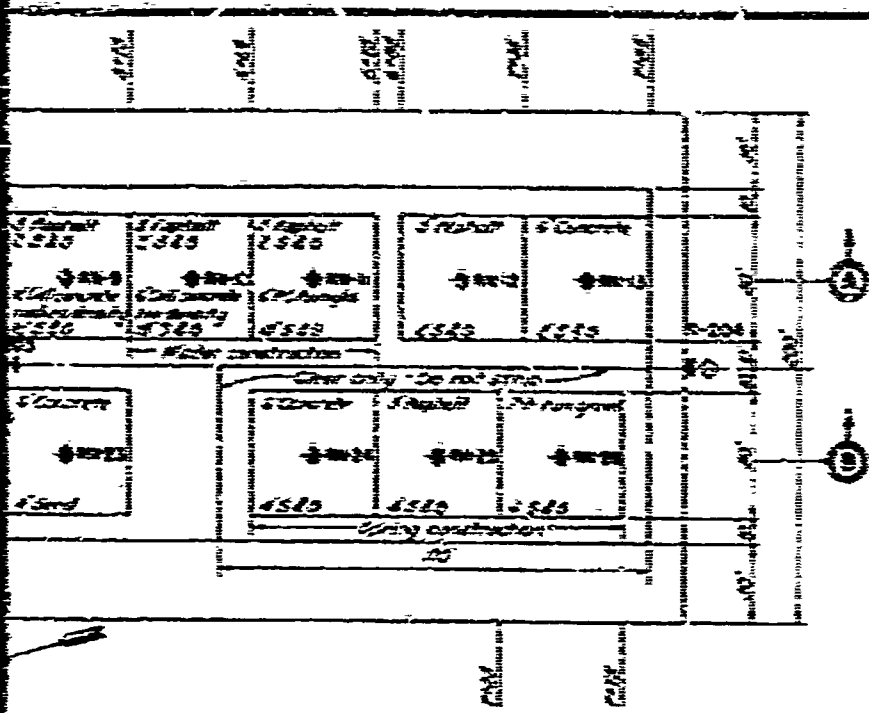

LEGEND

- ◆ S&S Core boring (Ground temperature hole)
- Q&Q Core boring (Ground temperature hole)
- ✦ Frost observation point.
- S&S Pit non sand and gravel.
- Limit of frozen and unfrozen zones with depth below surface of section.
- F Frozen zone
- U Unfrozen zone

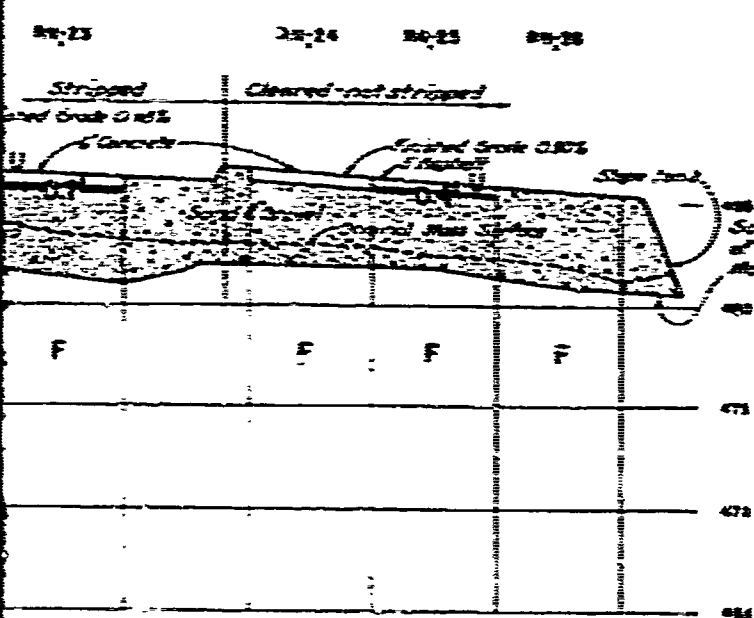

Note:
 In ground temperature hole 2-271, depth to permafrost 4.6.
 In ground temperature hole 2-274, depth to permafrost 5.0

PERMAFROST INVESTIGATION
FIELD RESEARCH
FAIRBANKS, ALASKA
AREA NO. 2
RUNWAY FOUNDATION STUDIES
FROZEN AND UNFROZEN ZONES
1 MAY 1948
 SCALE AS SHOWN

B

COPIES OF ENGINEERS, ST. PAUL, MINN. WAT FROU
 DRAWN BY E.C.T. CHECKED BY E.A.S. CHECKED BY

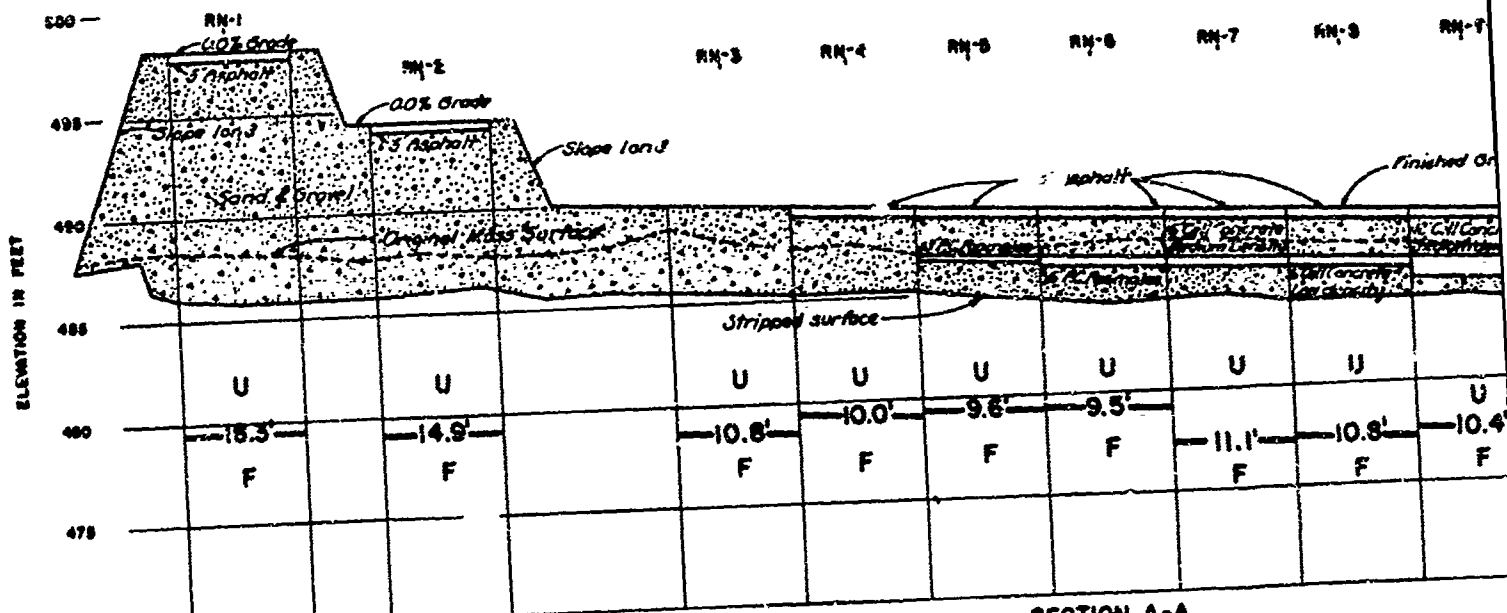
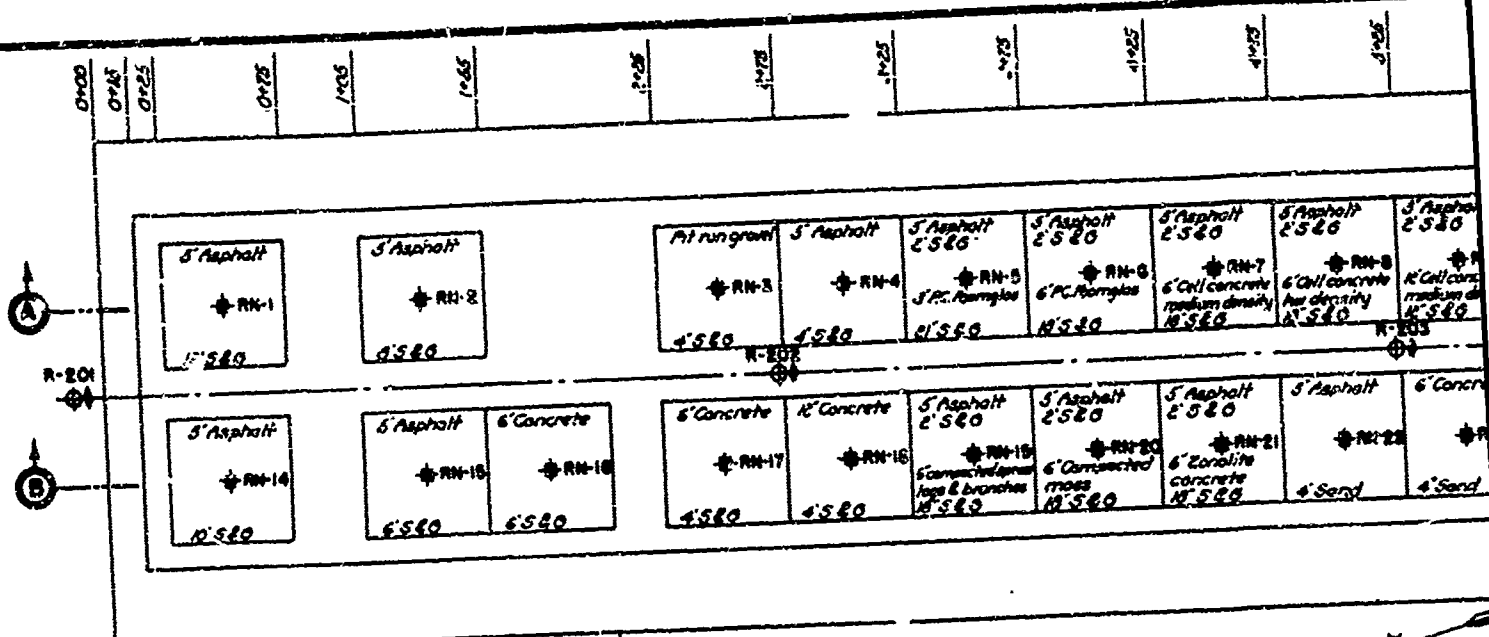

SECTION A-A

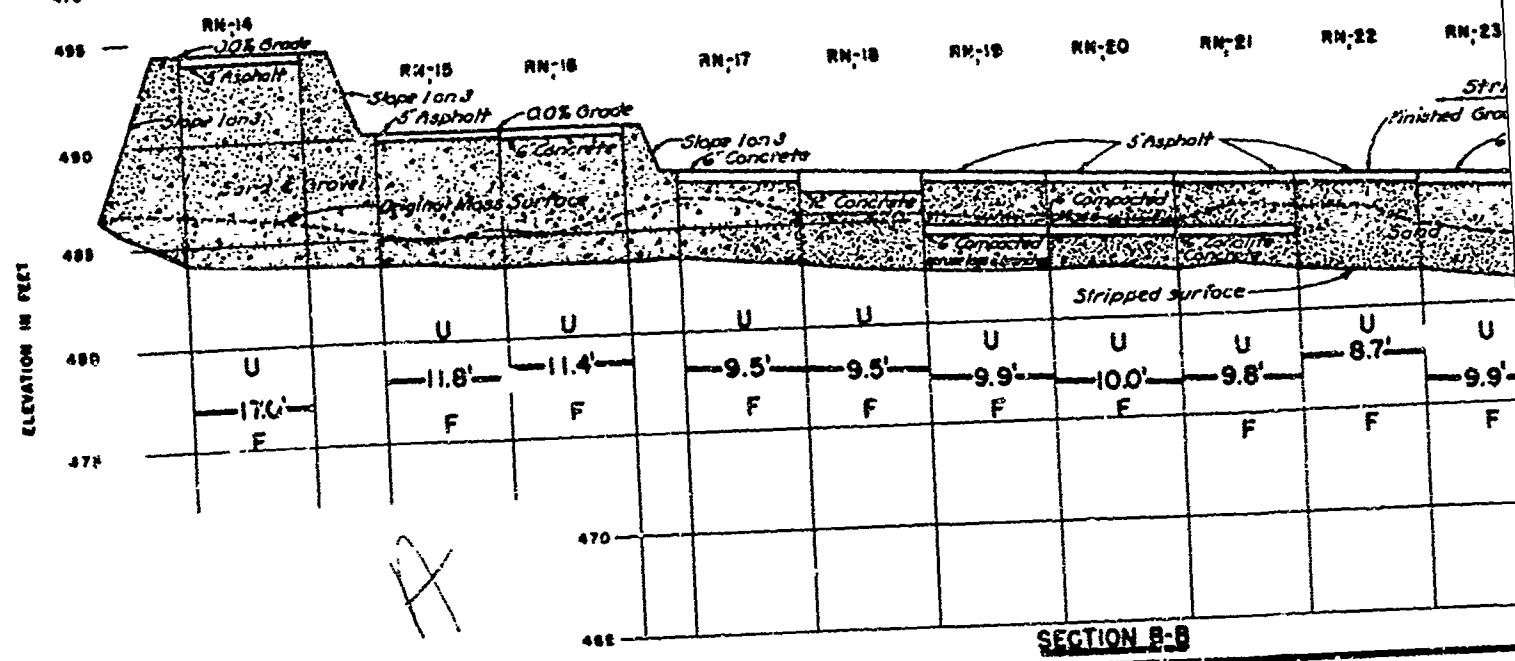

SECTION B-B

H

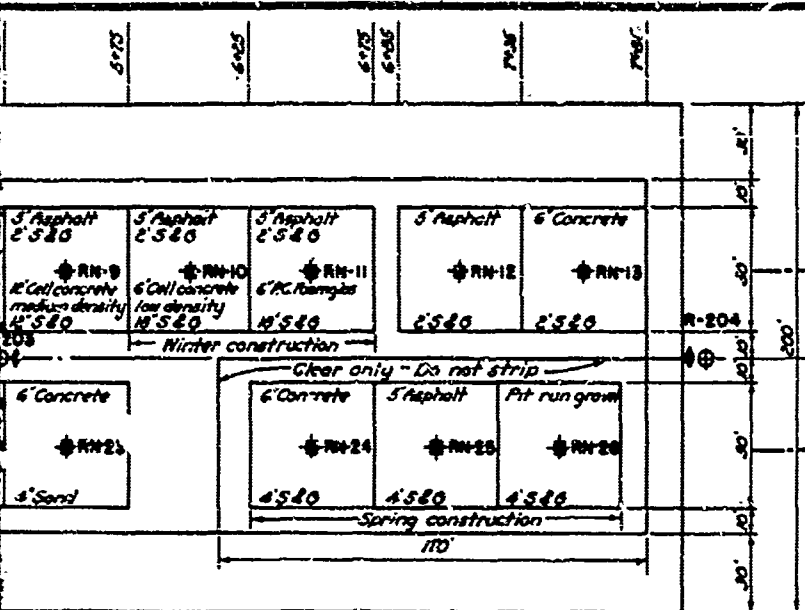

RN-9 RN-10 RN-11 RN-12 RN-13

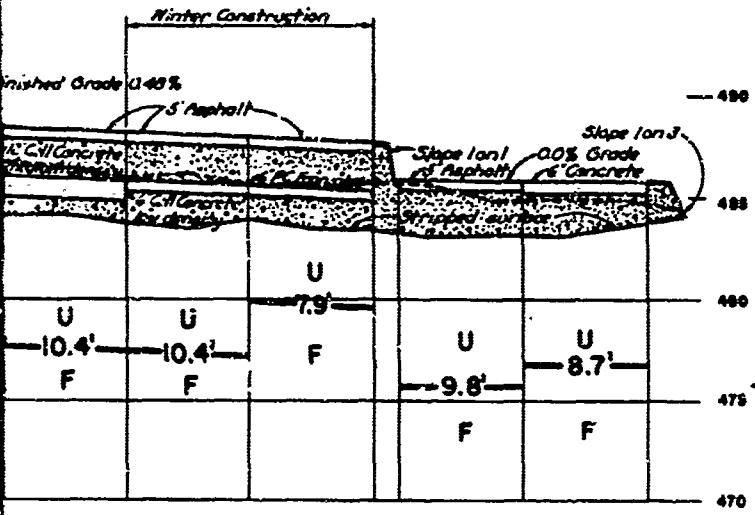

LEGEND

- ⊕ 30' Core boring (Ground temperature hole)
- ⊕ 15' Churn drill boring (Ground temperature hole)
- ◆ Frost observation point.
- S&G Pit run sand and gravel.
- 9.2- Limit of frozen and unfrozen zones with depth below surface of section.
- F Frozen zone.
- U Unfrozen zone.

RN-23 RN-24 RN-25 RN-26

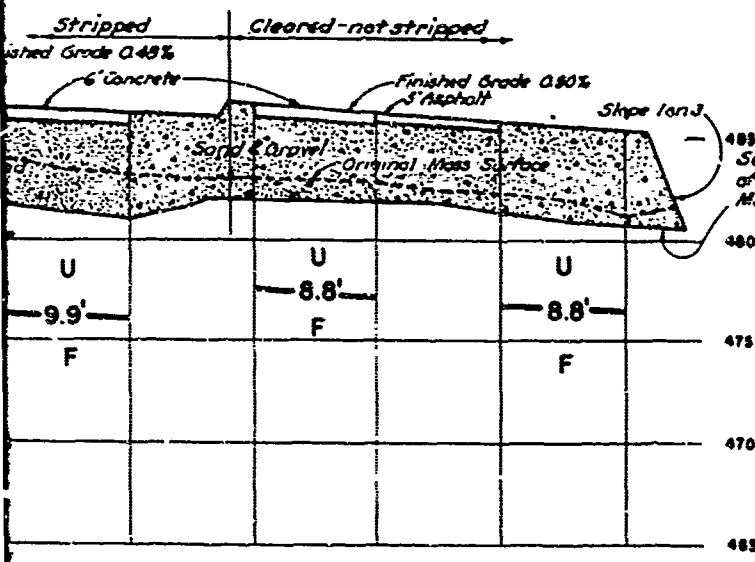

Note:
 At ground temperature hole R-201, depth to permafrost 4.6'.
 At ground temperature hole R-204, depth to permafrost 6.0'.

PERMAFROST INVESTIGATION
FIELD RESEARCH
FAIRBANKS, ALASKA
AREA NO. 2
RUNWAY FOUNDATION STUDIES
FROZEN AND UNFROZEN ZONES
1 OCTOBER 1948
 SCALE AS SHOWN

B

CORPS OF ENGINEERS, ST. PAUL, MINN. MAY 1950
 DRAWN BY: E.C.T. TRACED BY: M.J.S. CHECKED BY:

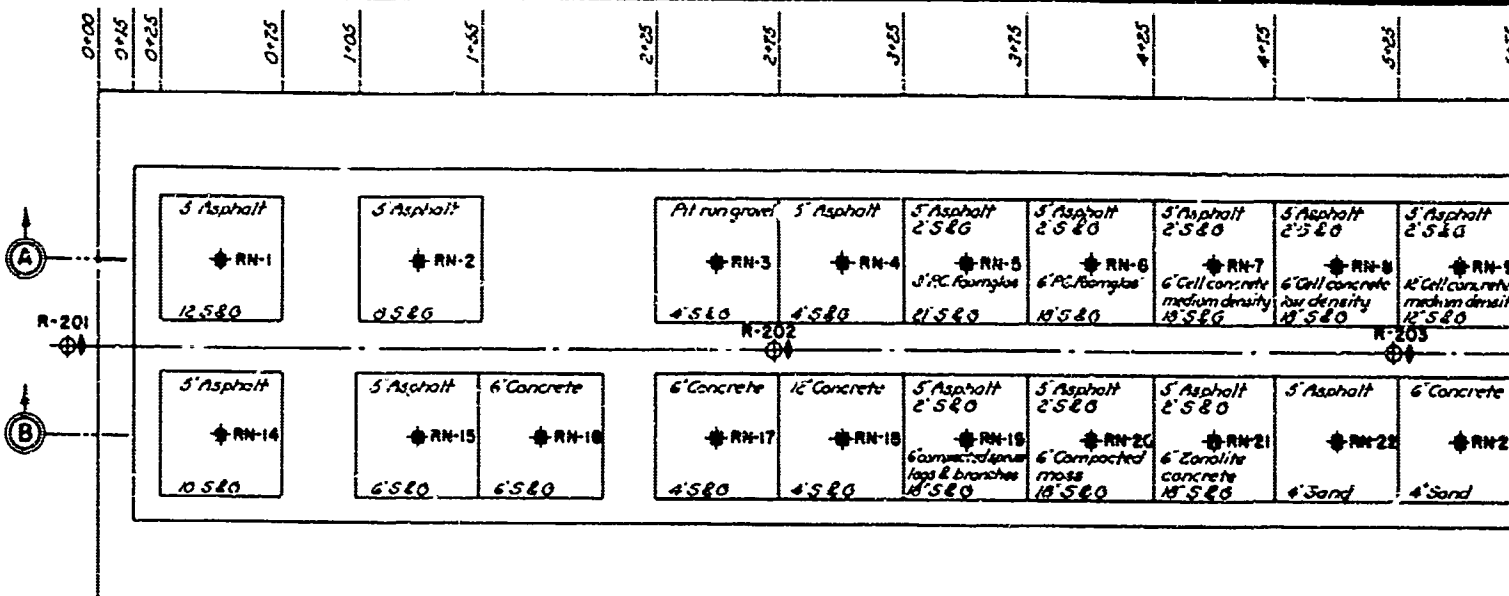

PLAN
 40 30 20 10 0 40 80
 SCALE IN FEET

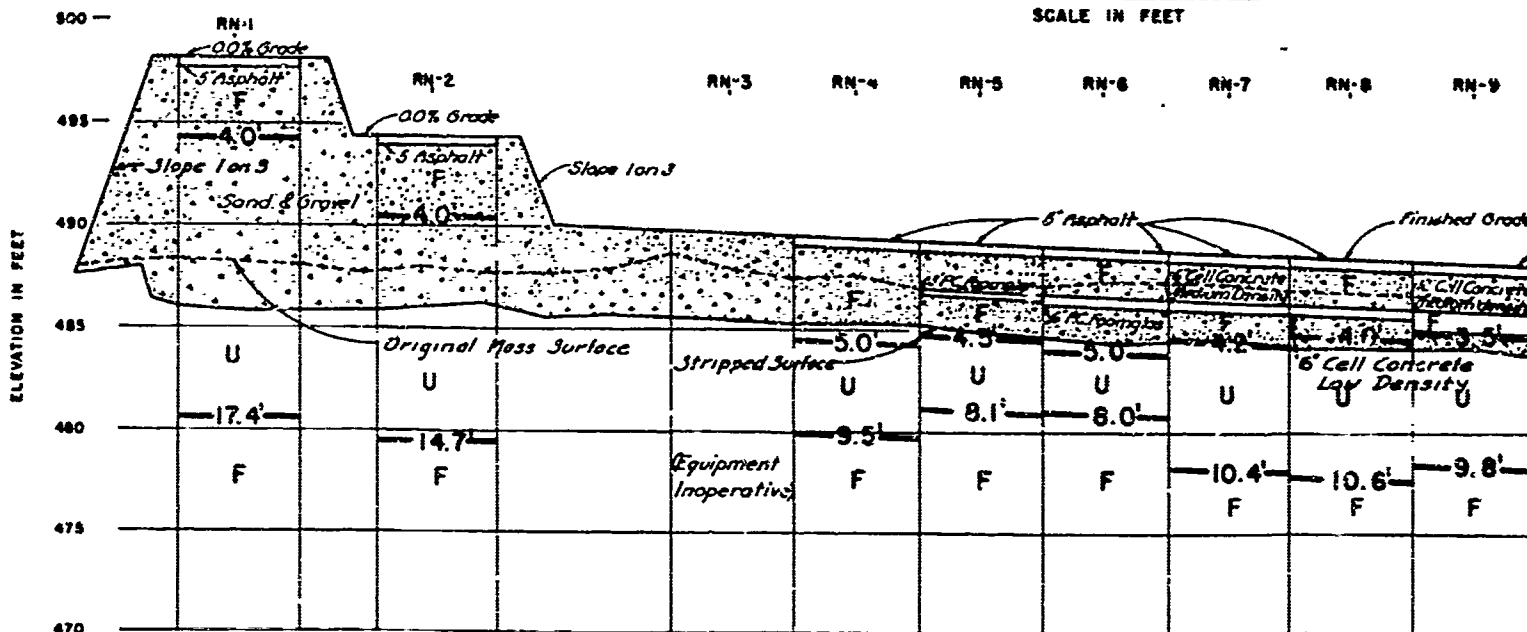

SECTION A-A

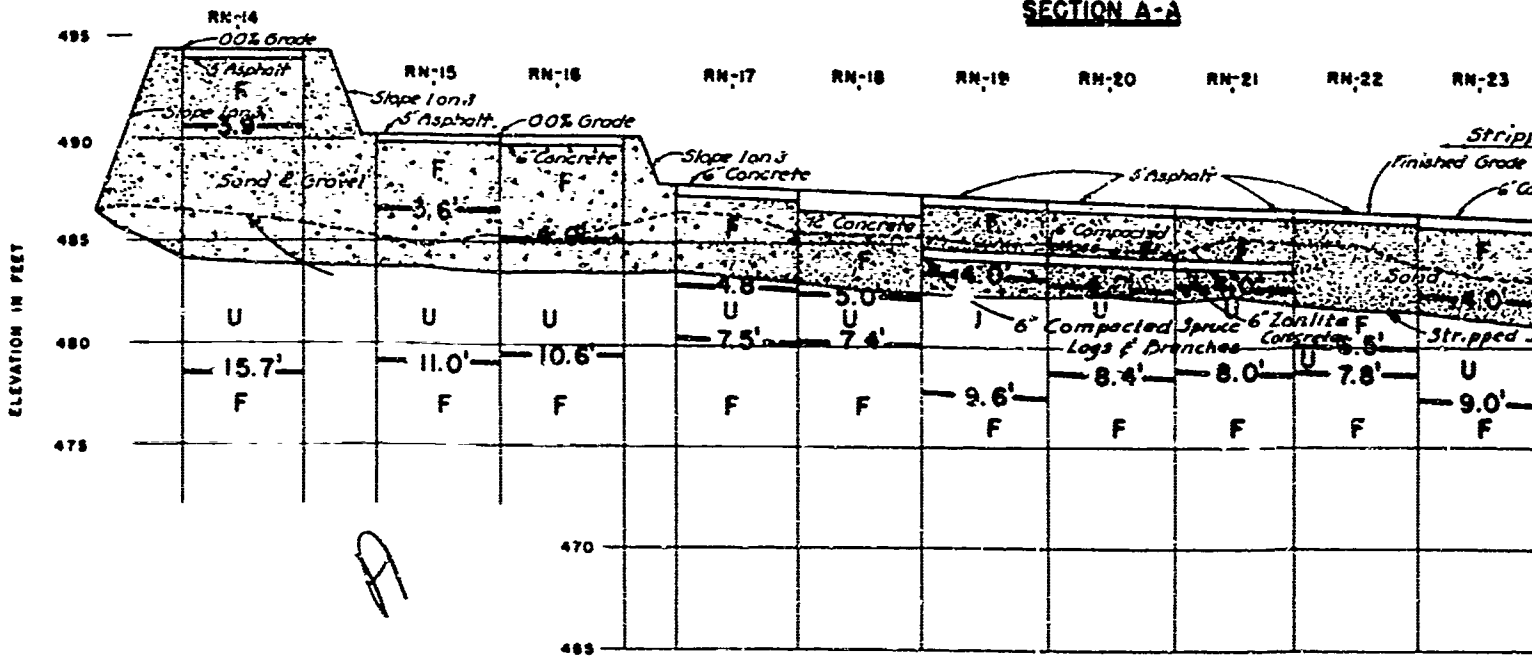

SECTION P-P

A

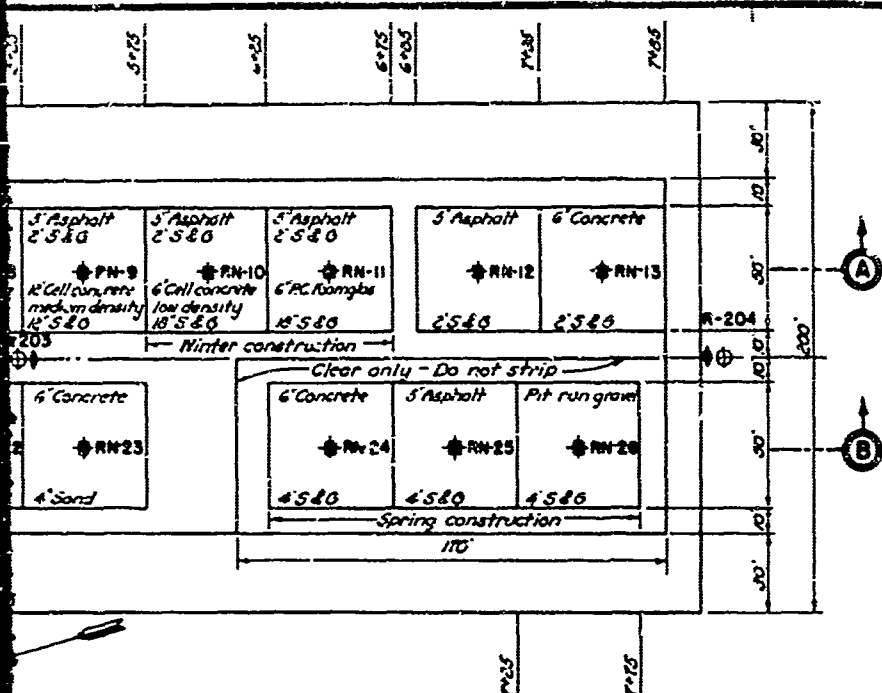

RN-9 RN-10 RN-11 RN-12 RN-13

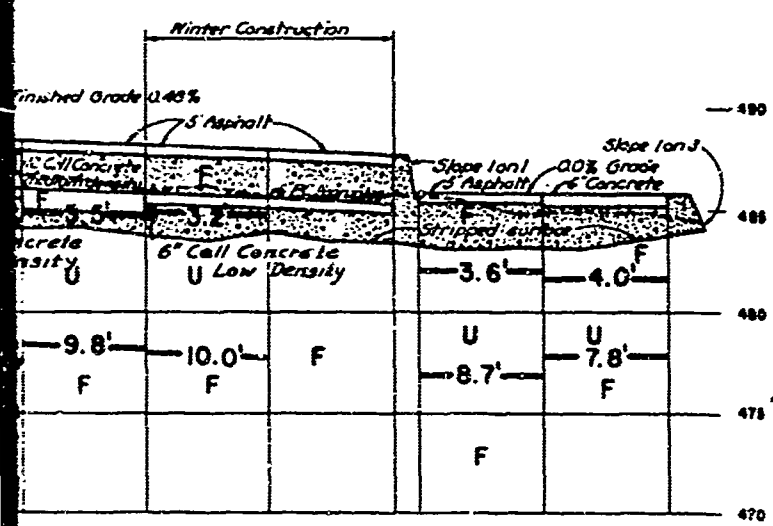

LEGEND

- ◆ 30' Core boring (Ground temperature hole)
- ◆ 15' Churn drill boring (Ground temperature hole)
- ◆ Frost observation point.
- S&G Pit run sand and gravel.
- 92- Limit of frozen and unfrozen zones with depth below surface of section.
- F Frozen zone
- U Unfrozen zone

RN-23 RN-24 RN-25 RN-26

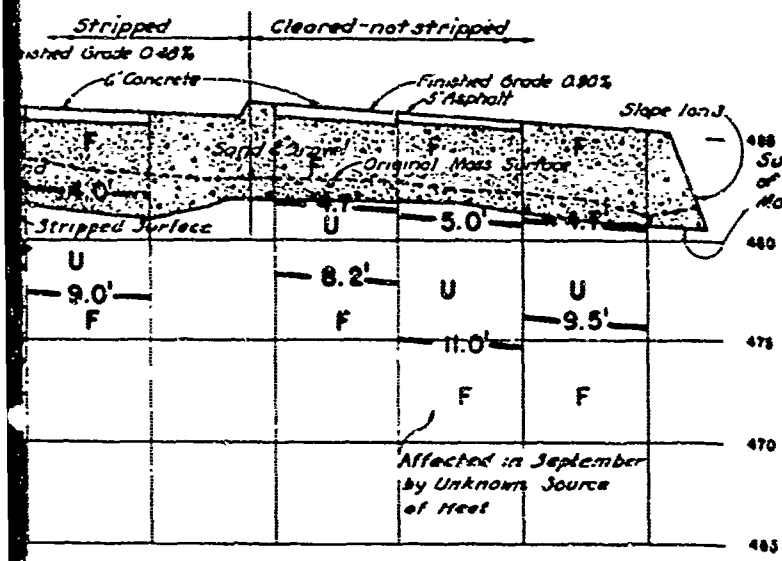

Note:
 At ground temperature hole R-201, depth to permafrost = 4.6'
 At ground temperature hole R-204, depth to permafrost = 6.0'

PERMAFROST INVESTIGATION
FIELD RESEARCH
FAIRBANKS, ALASKA
AREA NO. 2
RUNWAY FOUNDATION STUDIES
FROZEN AND UNFROZEN ZONES
31 OCTOBER 1948
 SCALE AS SHOWN

CORPS OF ENGINEERS, ST. PAUL, MINN. MAY 1950
 DRAWN BY: E.C.T. TRACED BY: M.J.S. CHECKED BY:

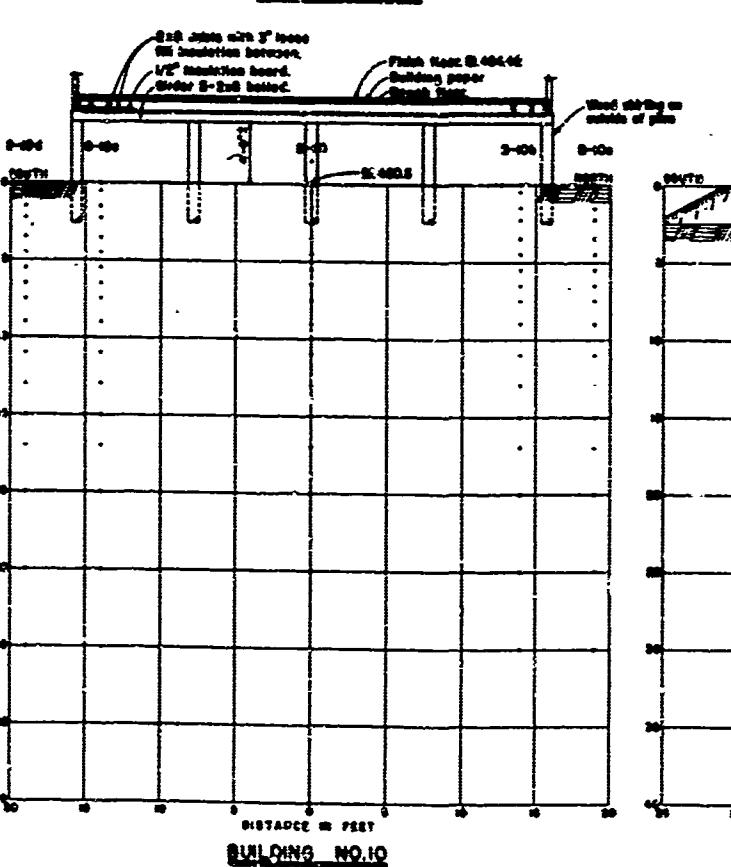
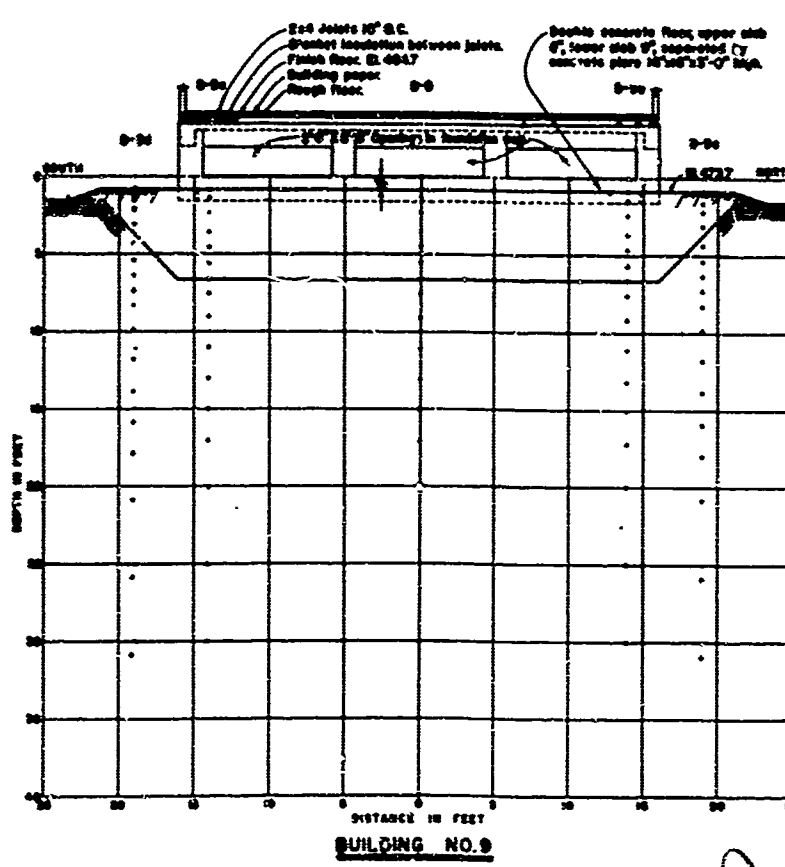
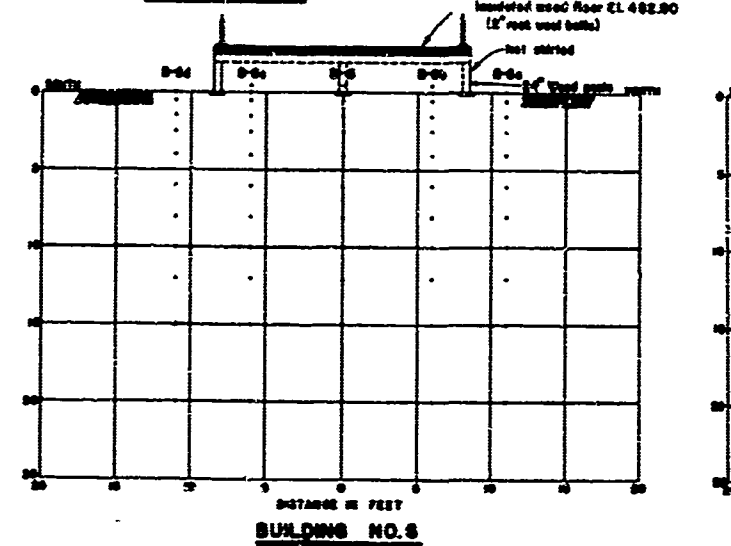
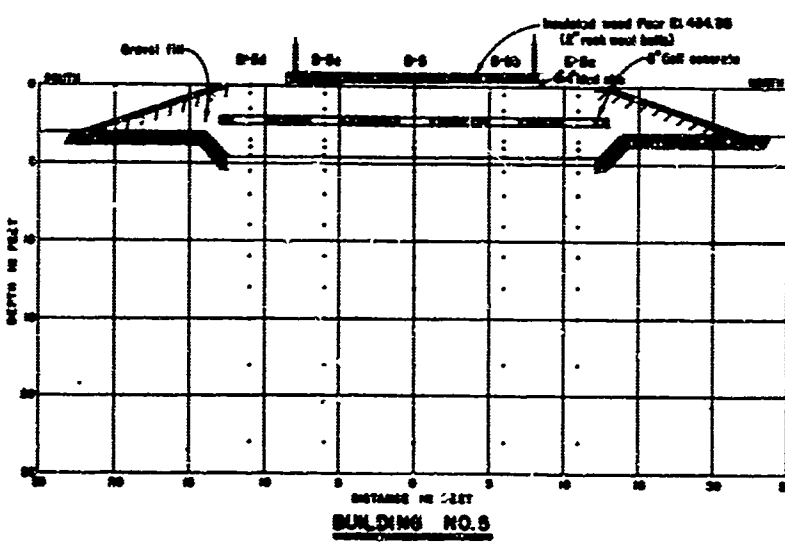
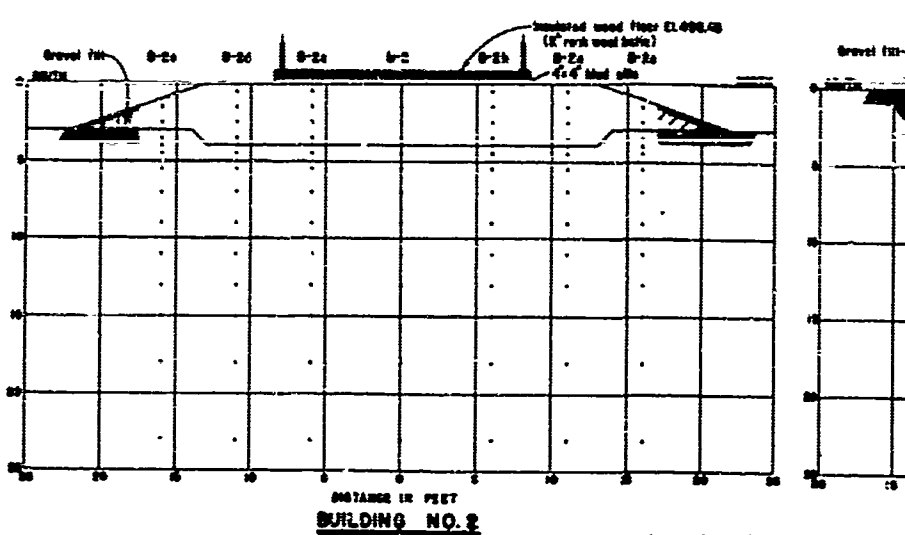
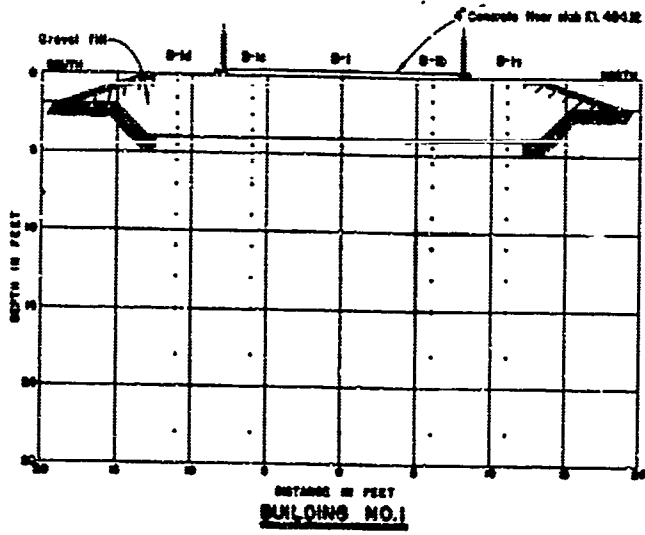

A

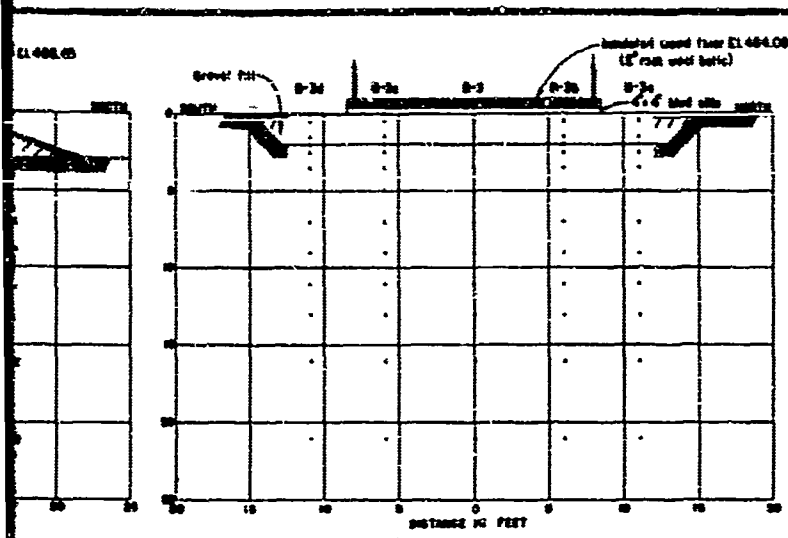

BUILDING NO. 3

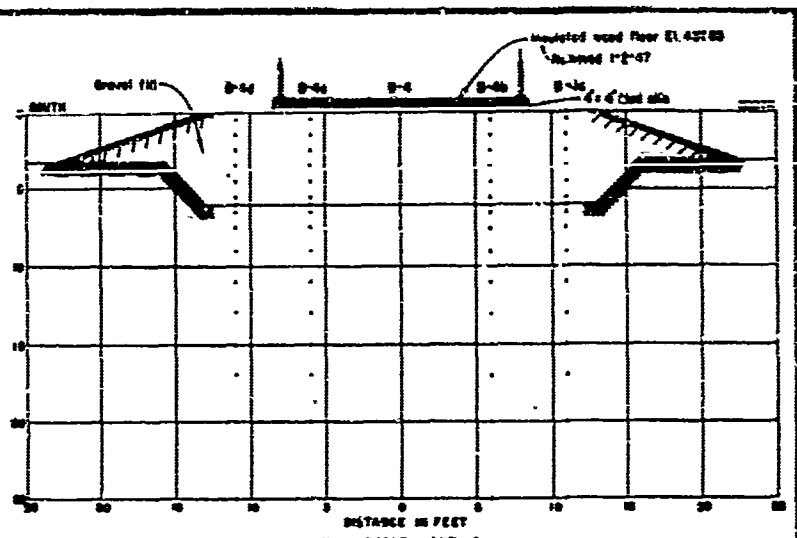

BUILDING NO. 4

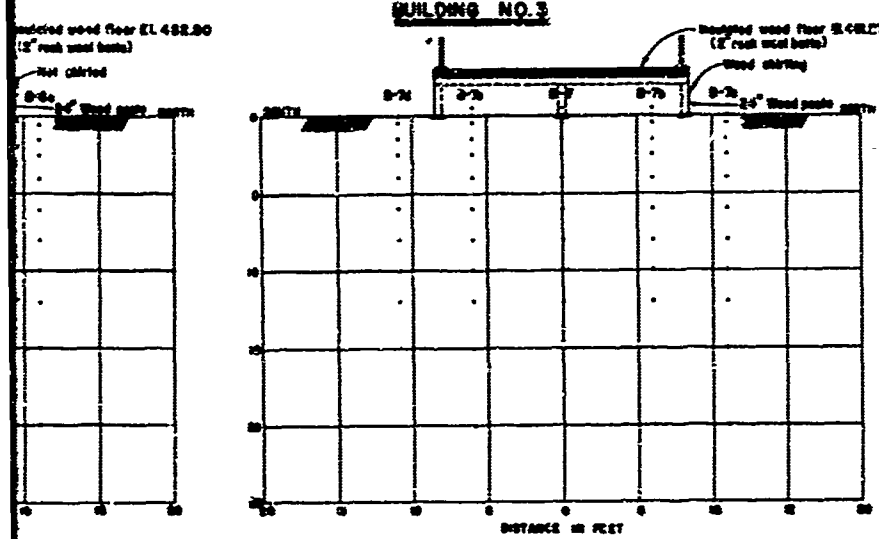

BUILDING NO. 7

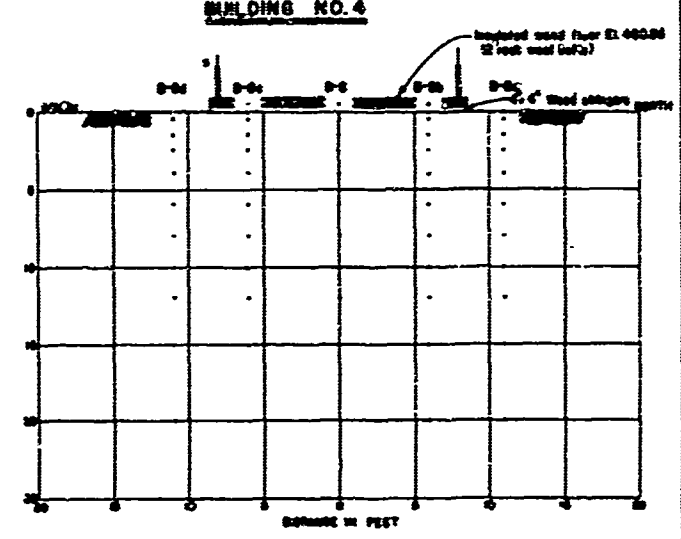

BUILDING NO. 8

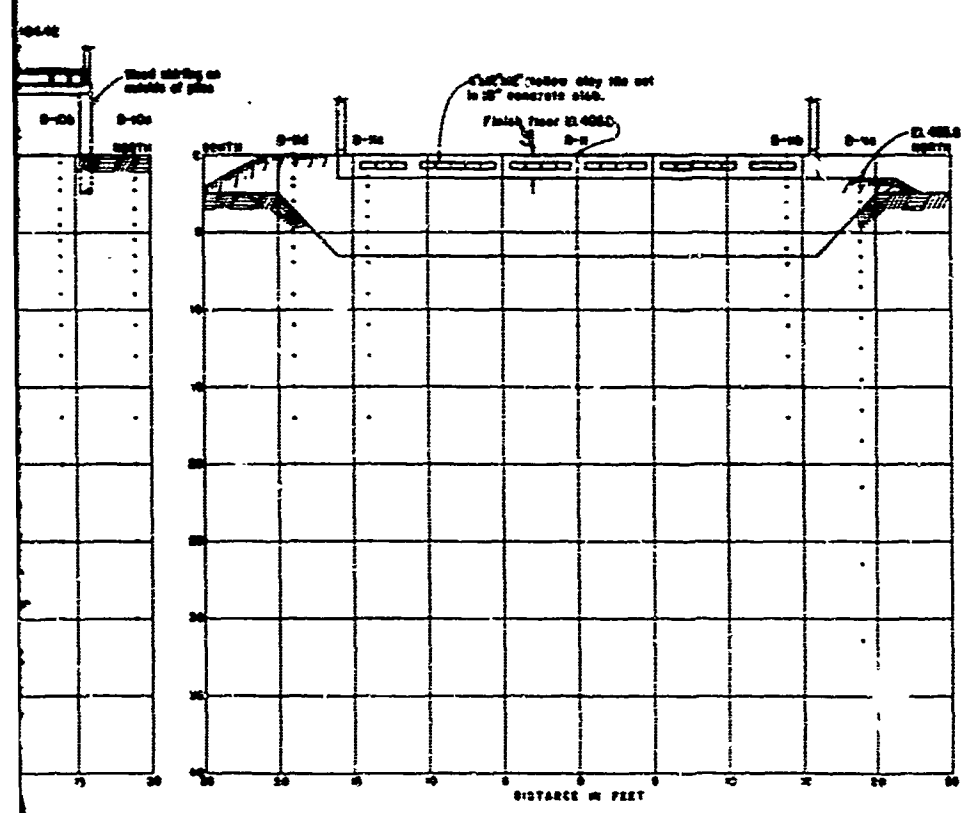

BUILDING NO. 11

NOTE:
 1. PILE AND THE STRAPPING USES BUILDING AT LOW POINT OF SLOPE TO PROVIDE DRAINAGE.
 2. IN ORDER TO TEST THE EFFECT OF AN INSULATED WOOD FLOOR, THE INSULATION WAS REMOVED FROM THE FLOOR OF BUILDING NO. 4 ON 3 JANUARY 1947.

**PERMAFROST INVESTIGATION
 FIELD RESEARCH
 FAIRBANKS, ALASKA
 AREA NO. 3
 BUILDING FOUNDATIONS**

SCALE AS SHOWN
 COMPS OF ENGINEERS ST. PAUL, MINN. MAY 1950
 DRAWN BY P.P.E. TRACED BY S.P.E. CHECKED BY

B

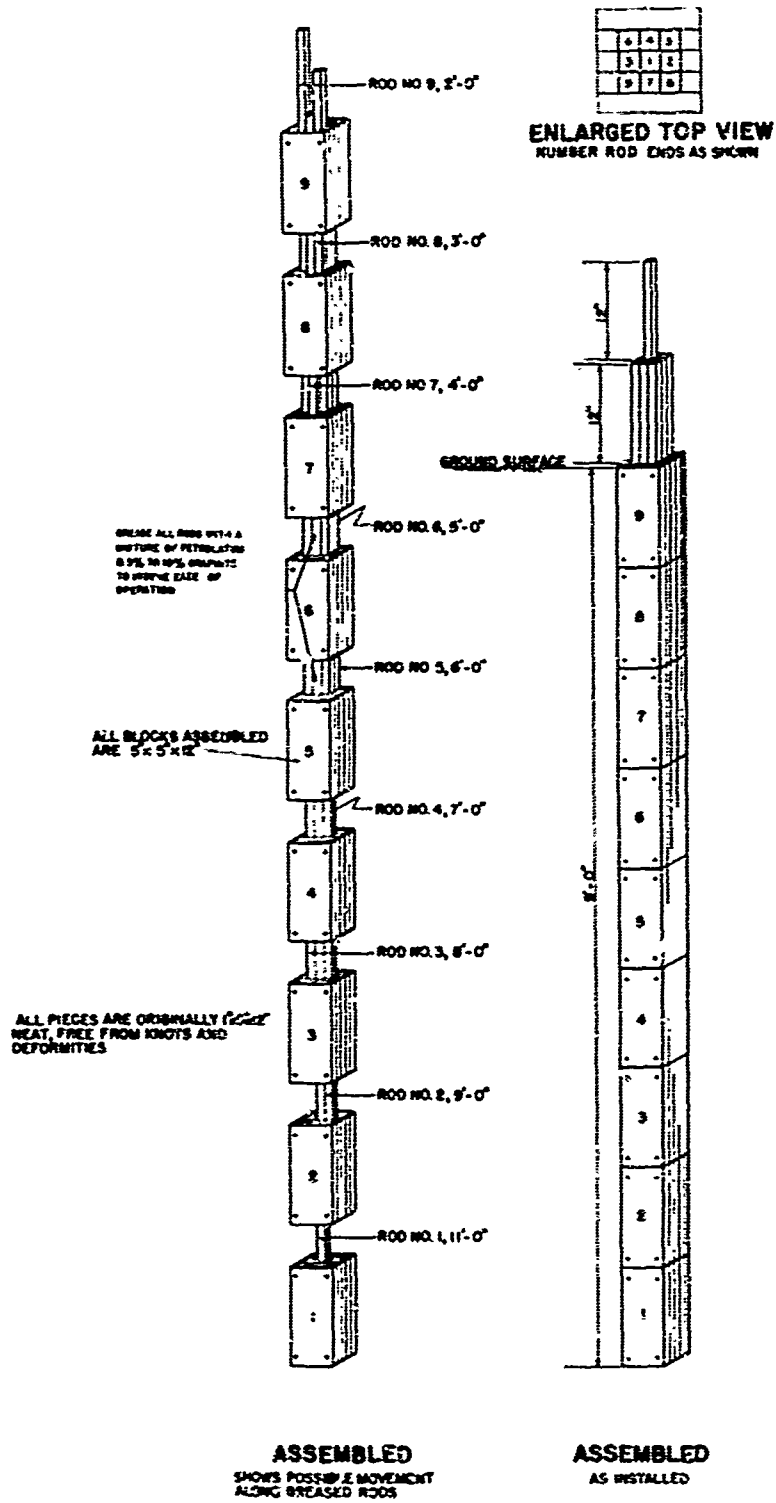

PERMAFROST INVESTIGATION
FIELD RESEARCH-FAIRBANKS, ALASKA
AREA NO. 3
DESIGN OF SWELLOMETER

CORPS OF ENGINEERS, ST. PAUL, MINN. MAY 1950

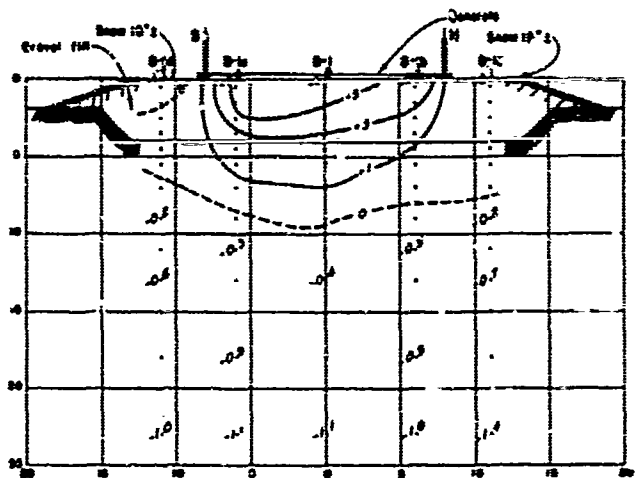

BUILDING NO. 1

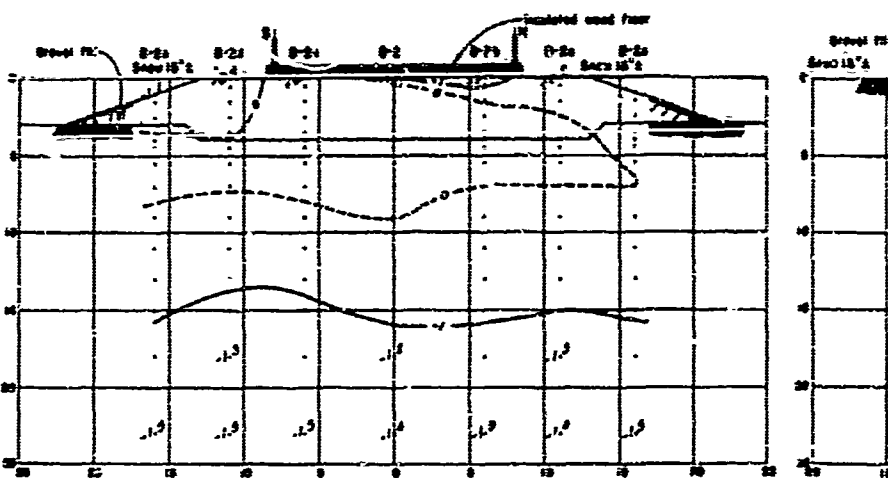

BUILDING NO. 2

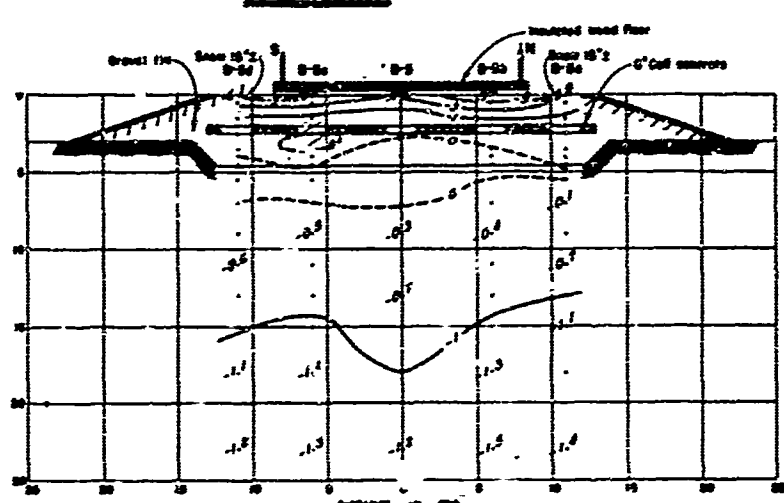

BUILDING NO. 3

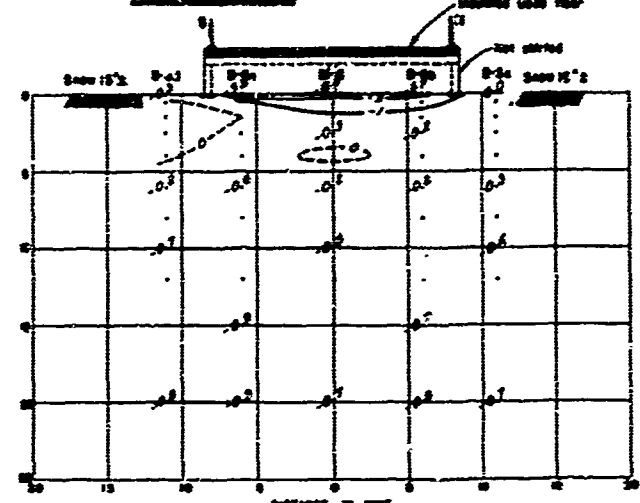

BUILDING NO. 4

A

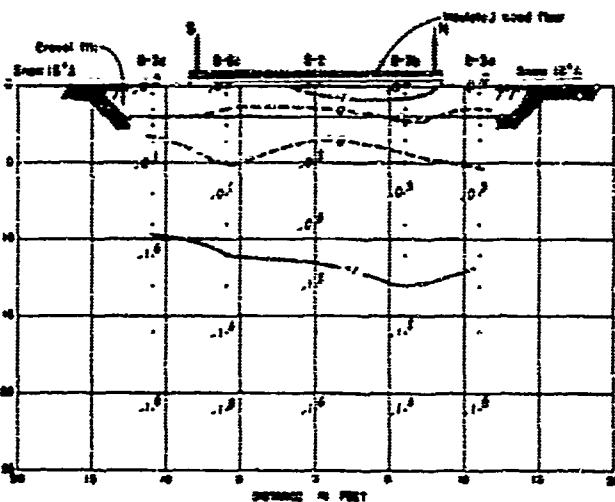

BUILDING NO. 3

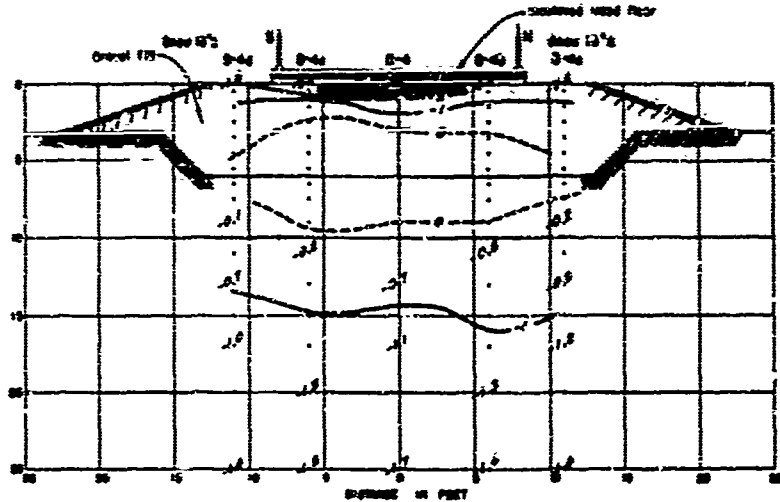

BUILDING NO. 4

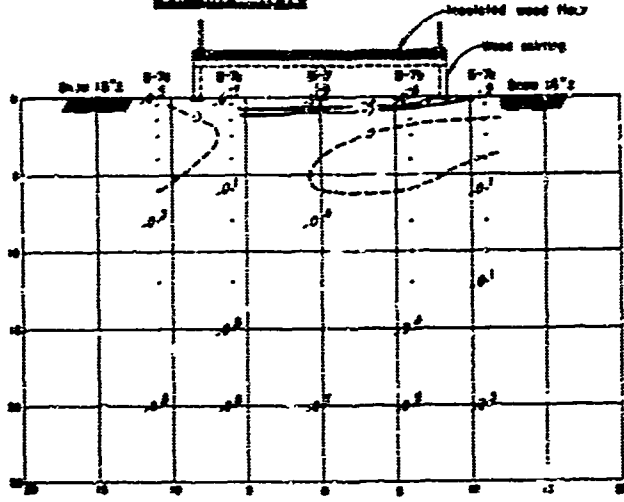
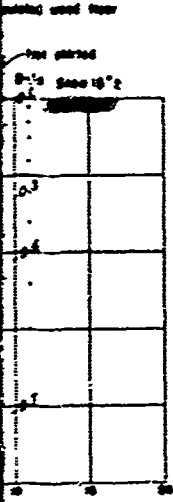

BUILDING NO. 7

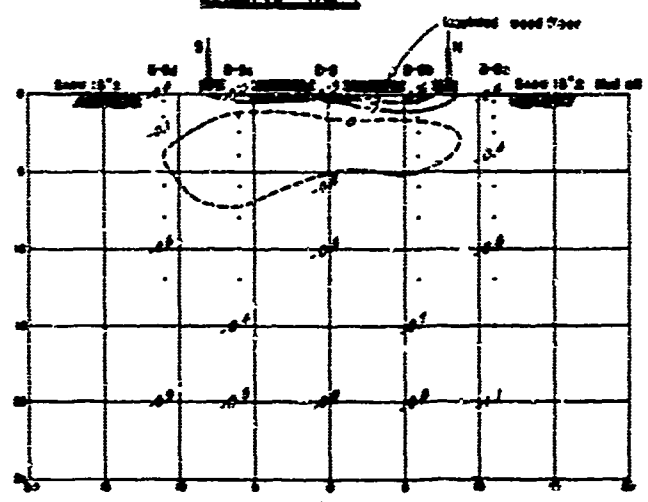

BUILDING NO. 8

B

Note:
 Building locations shown on plate II-7
 Temperature observations shown
 in degrees centigrade
 - - - - - Zero isotherm
 ———— Isotherms other than zero

**PERMAFROST INVESTIGATION
 FIELD RESEARCH
 FAIRBANKS, ALASKA
 AREA NO. 3
 GROUND TEMPERATURE OBSERVATIONS
 1 NOVEMBER 1946**

SCALE: AS SHOWN
 CORPS OF ENGINEERS ST. PAUL, MINN. MAY, 1946
 DRAWN BY E.P.S. TRACED BY E.P.S. CHECKED BY

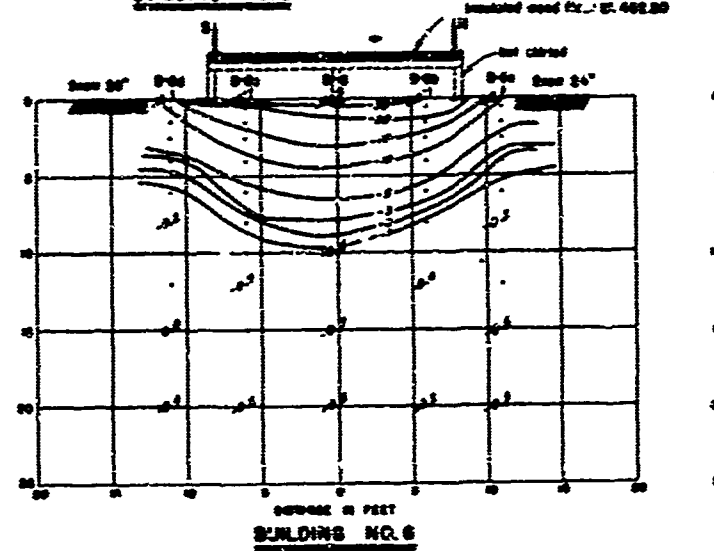
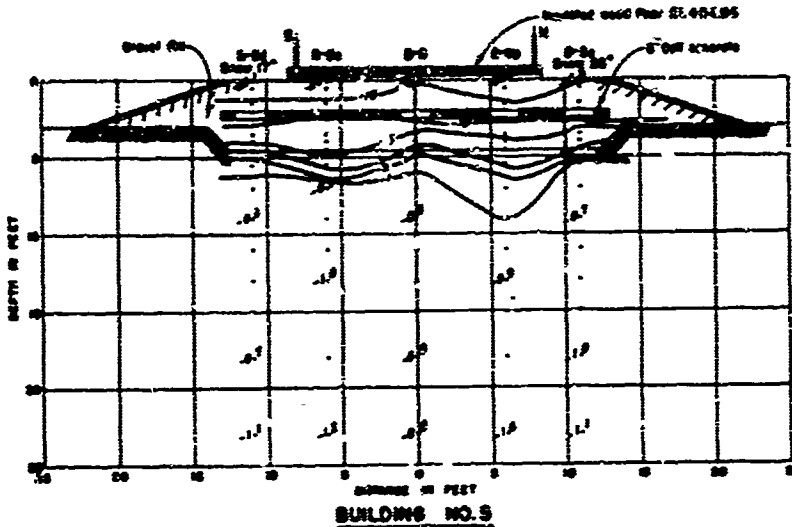
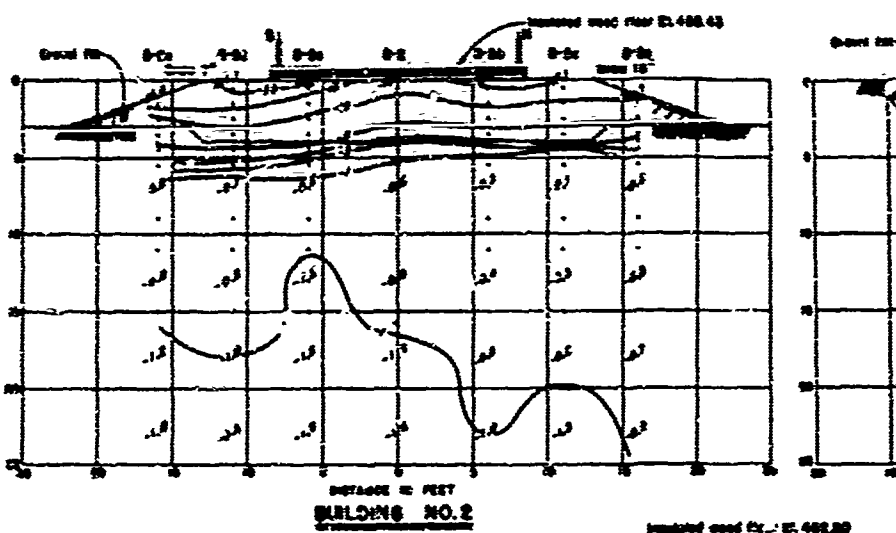
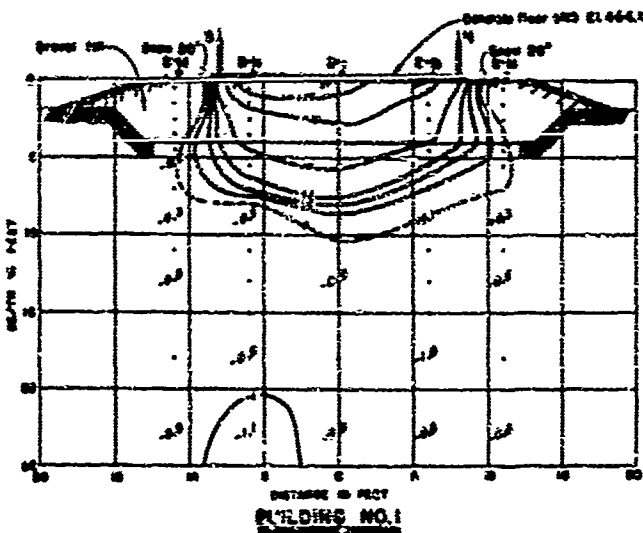

A

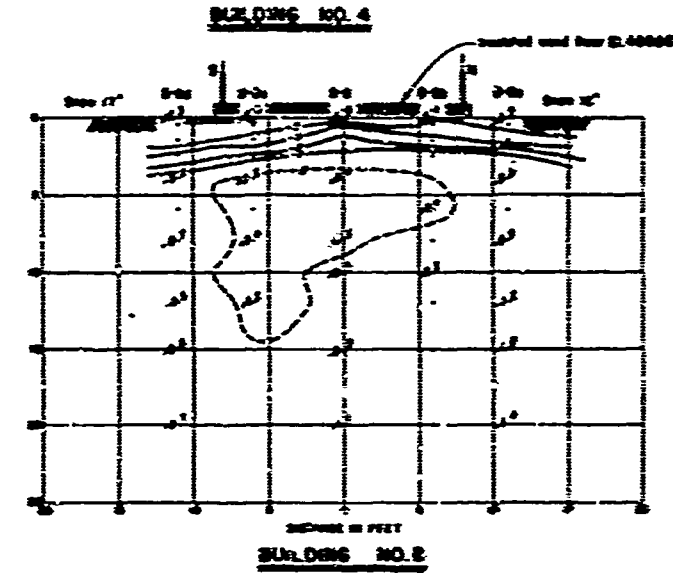
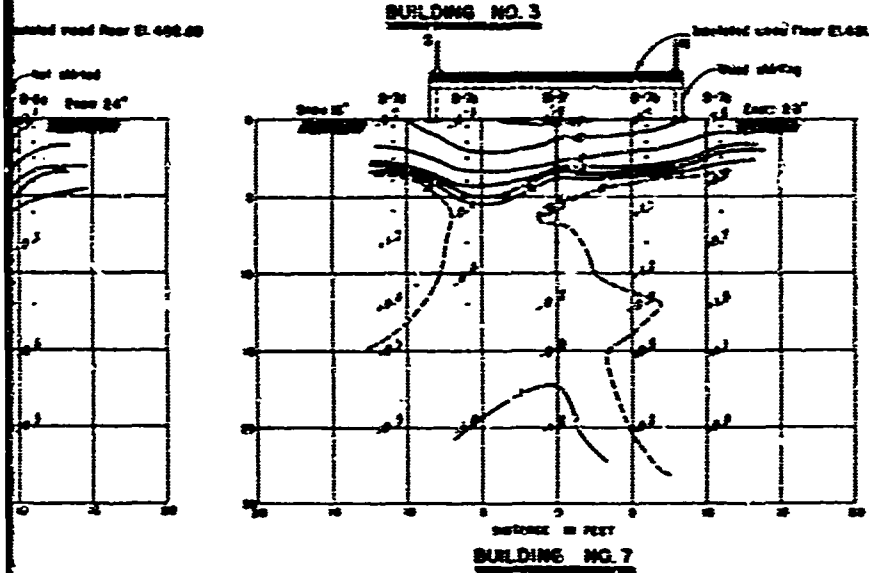
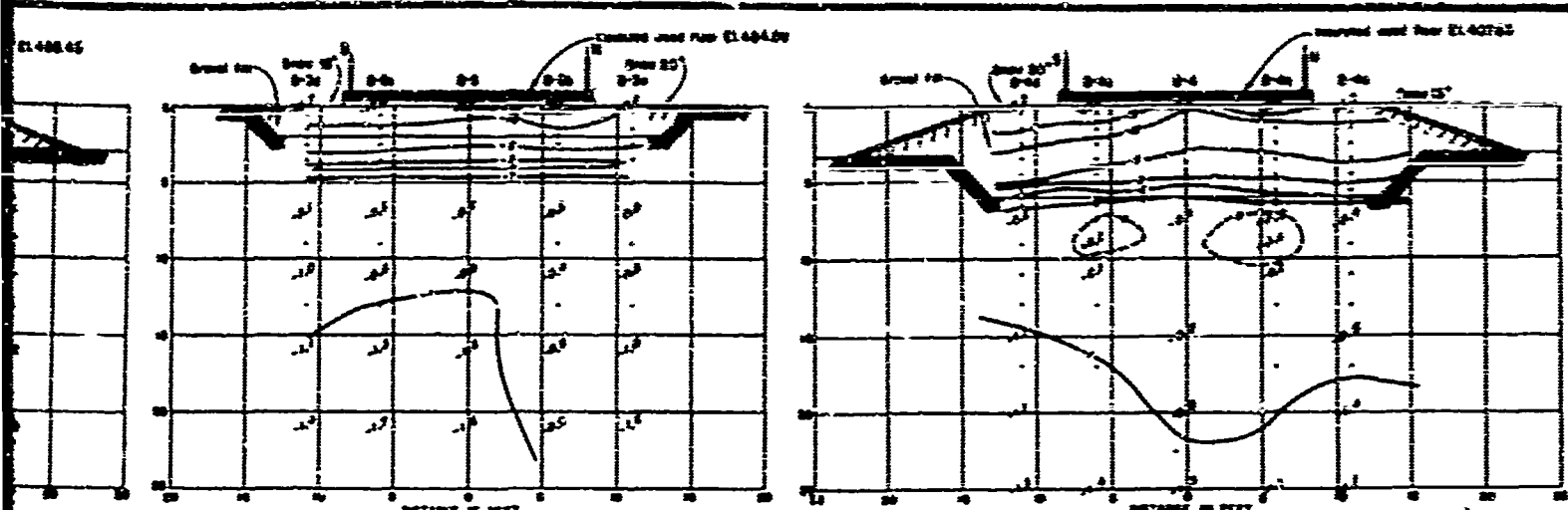

B

NOTE:
 Dotted lines show on plate 2E T
 Temperature observations shown
 in degrees centigrade
 — Zero isotherm
 — Isotherms other than zero

PERMAFROST INVESTIGATION
 FIELD RESEARCH
 FAIRBANKS, ALASKA
 AREA NO. 3
 GROUND TEMPERATURE OBSERVATIONS
 1 FEBRUARY 1947
 SCALE AS SHOWN
 CORPS OF ENGINEERS U. S. ARMY 37' 3000
 DRAWN BY P. S. CHECKED BY P. S. DESIGNED BY

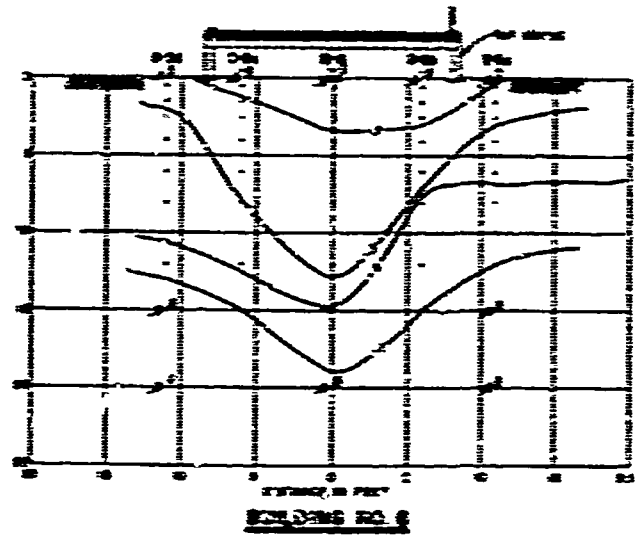
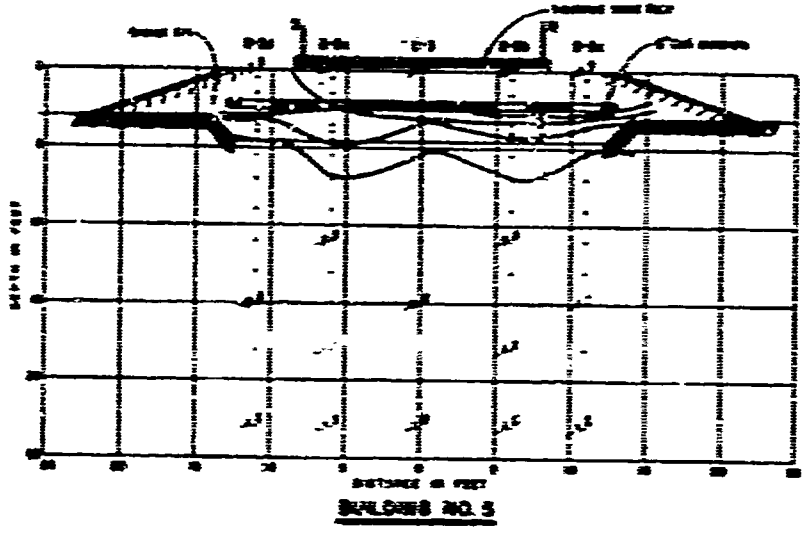
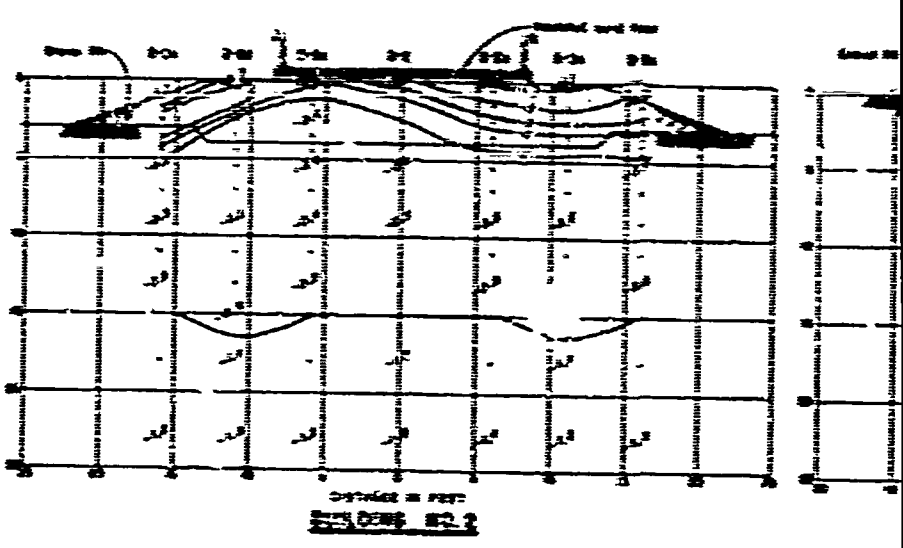
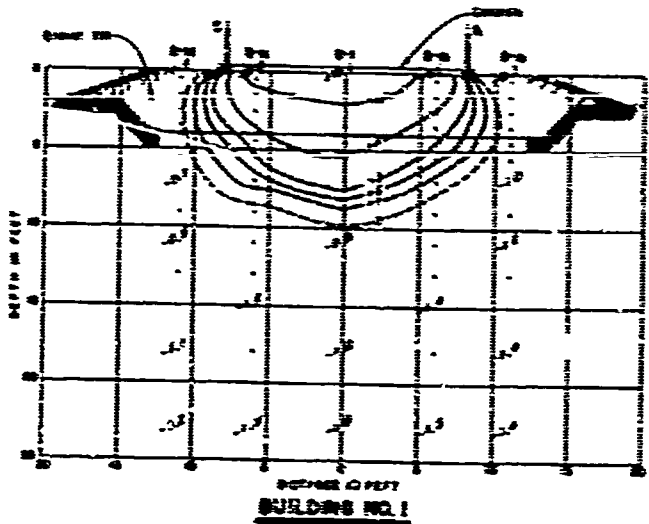

R

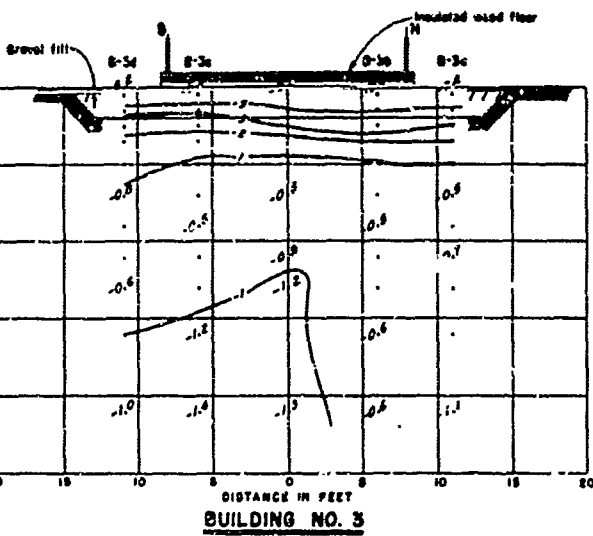

BUILDING NO. 3

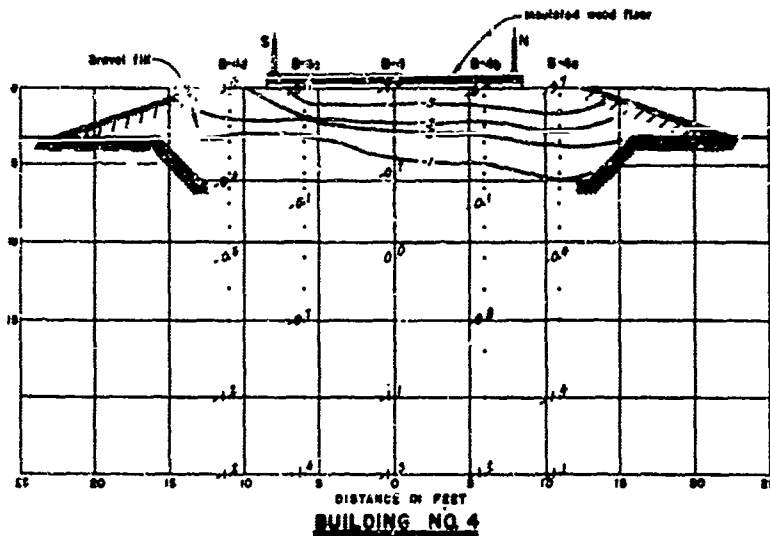

BUILDING NO. 4

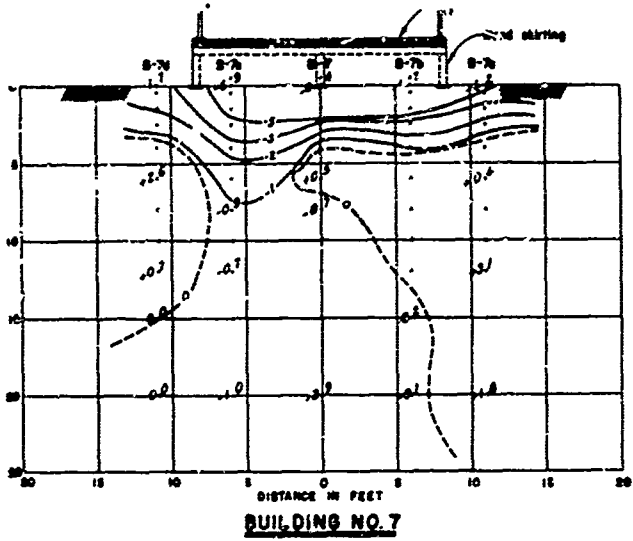
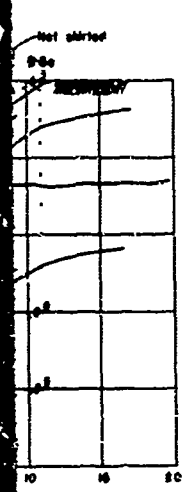

BUILDING NO. 7

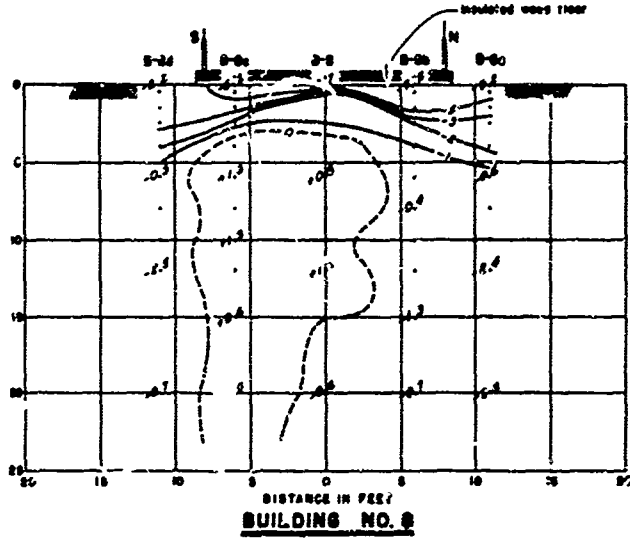

BUILDING NO. 8

B

Note:
 Building locations shown on plate III-7
 Temperature observations shown
 in degrees centigrade
 ----- Zero isotherm
 _____ Isotherms other than zero

**PERMAFROST INVESTIGATION
 FIELD RESEARCH
 FAIRBANKS, ALASKA
 AREA NO. 3
 GROUND TEMPERATURE OBSERVATIONS
 1 APRIL 1947**

SCALE: AS SHOWN
 CORPS OF ENGINEERS ST. PAUL, MINN. MAY 1949
 DRAWN BY: R. R. G. TRACED BY: R. R. G. CHECKED BY:

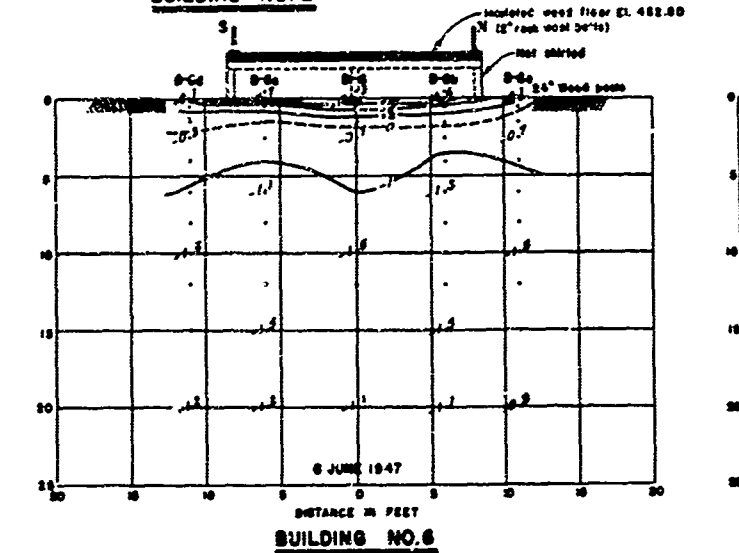
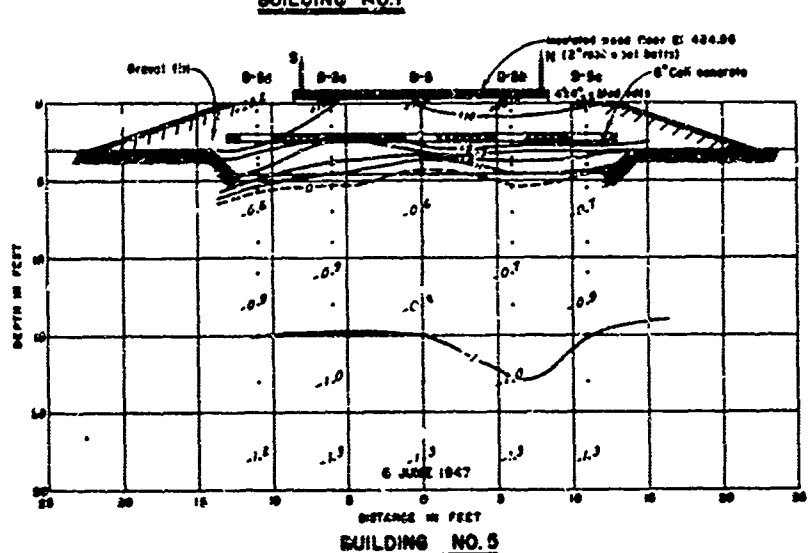
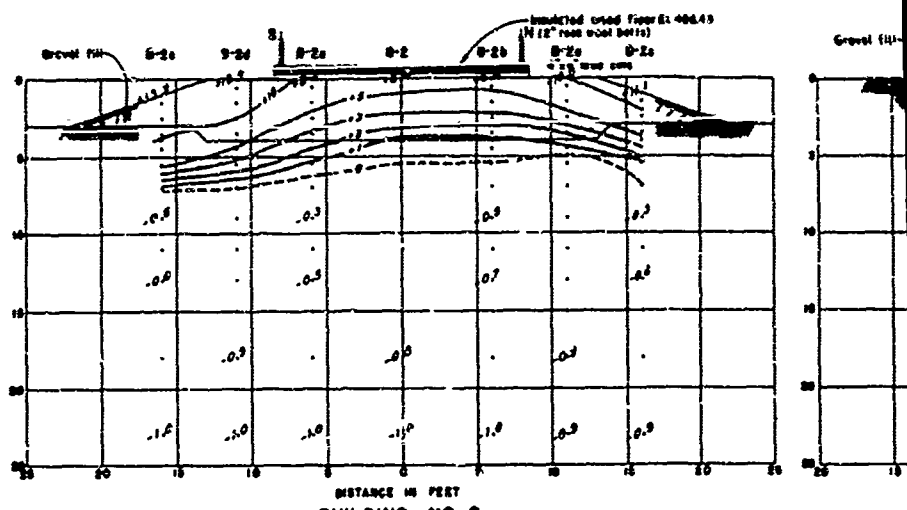
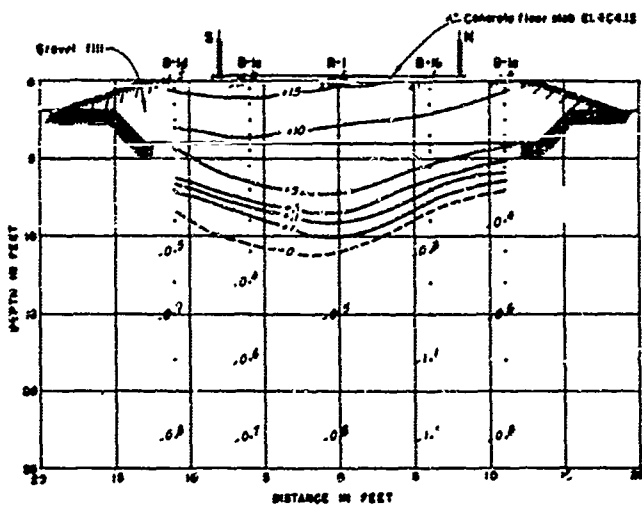

H

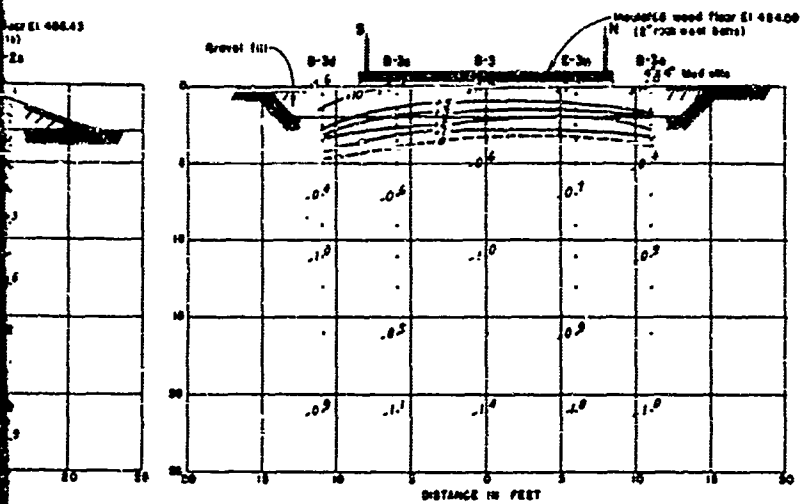

BUILDING NO. 3

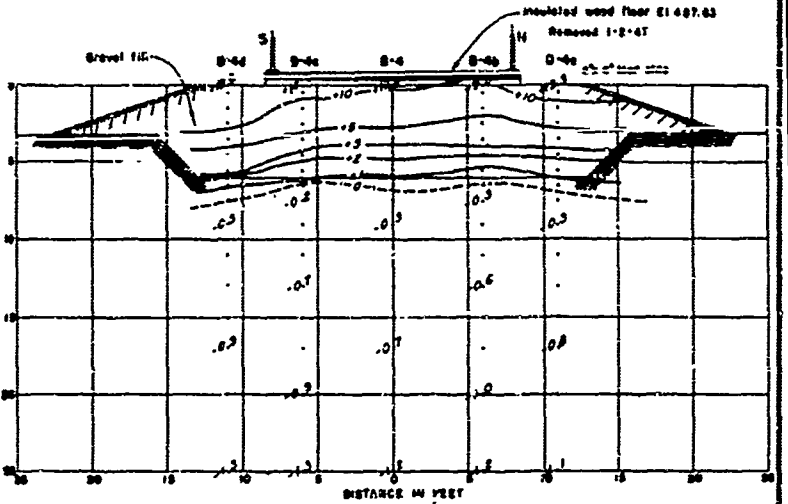

BUILDING NO. 4

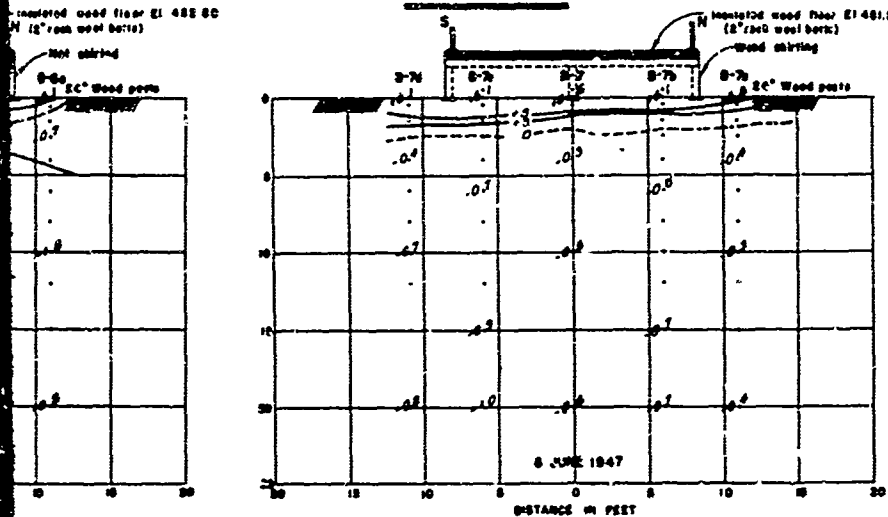

BUILDING NO. 7

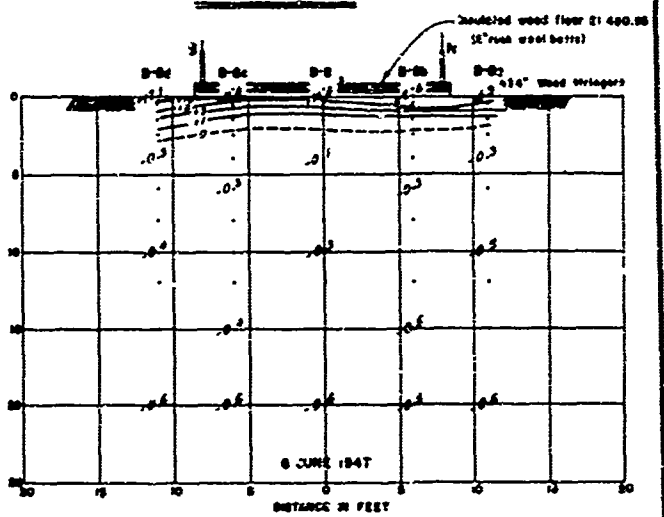

BUILDING NO. 8

B

Note:
 Building locations shown on plate III-7
 Temperature observations shown
 in degrees centigrade
 - - - - Zero isotherm
 ——— Isotherms other than zero

**PERMAFROST INVESTIGATION
 FIELD RESEARCH
 FAIRBANKS, ALASKA
 AREA NO. 3
 GROUND TEMPERATURE OBSERVATIONS
 5 JUNE 1947**

SCALE AS SHOWN
 CORPS OF ENGINEERS ST. PAUL, MINN. MAY 1950
 DRAWN BY P. S. C. TRACED BY P. S. C. CHECKED BY

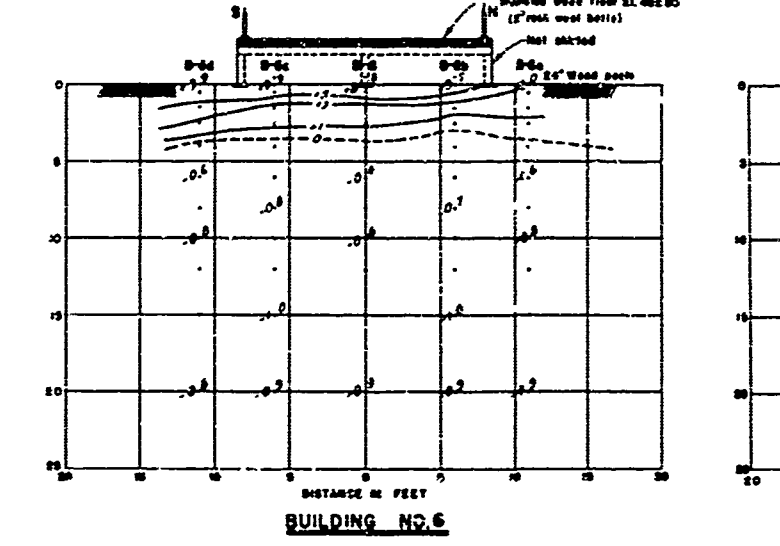
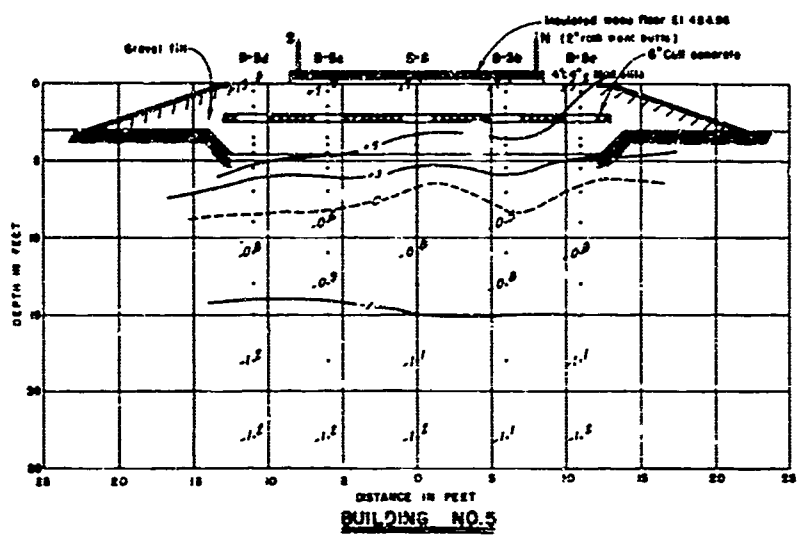
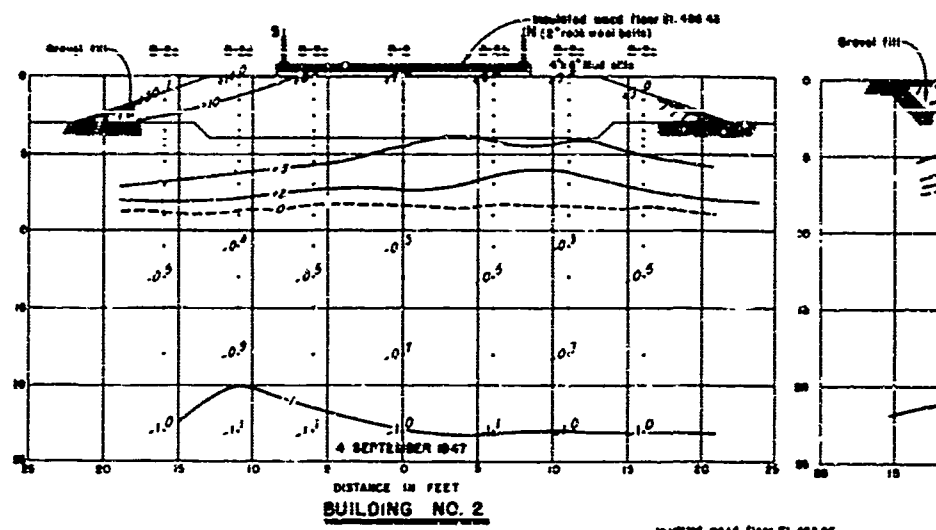
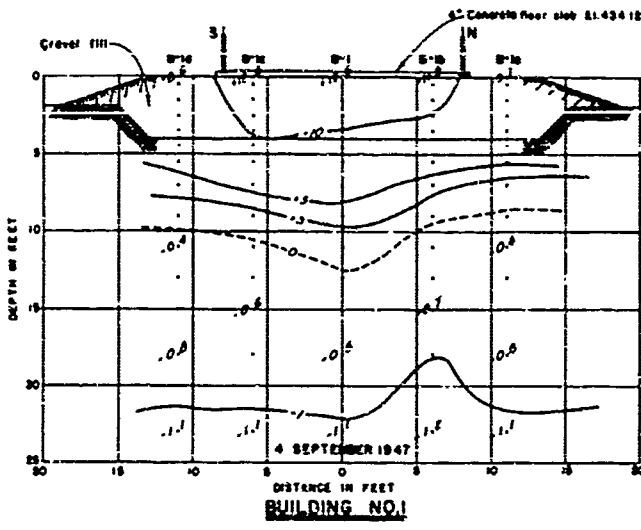

A

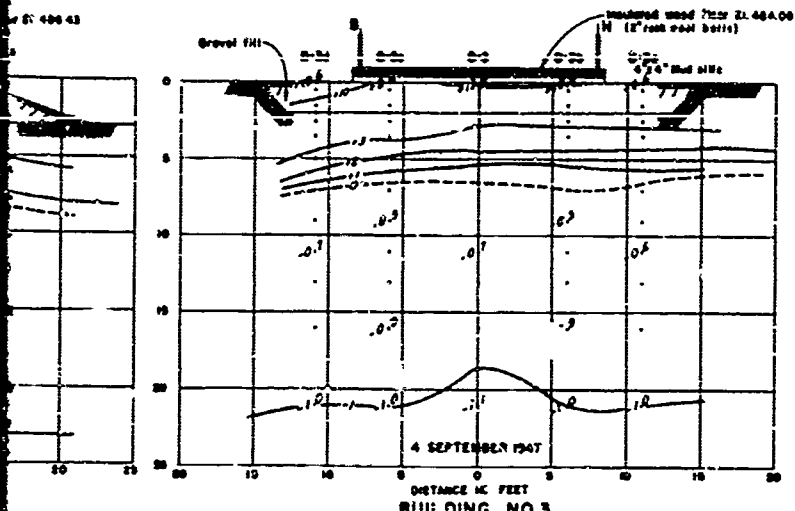

BUILDING NO. 3

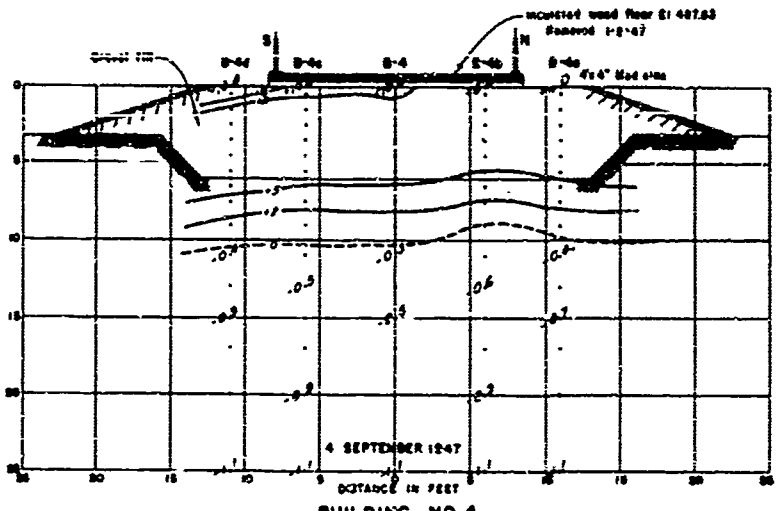

BUILDING NO. 4

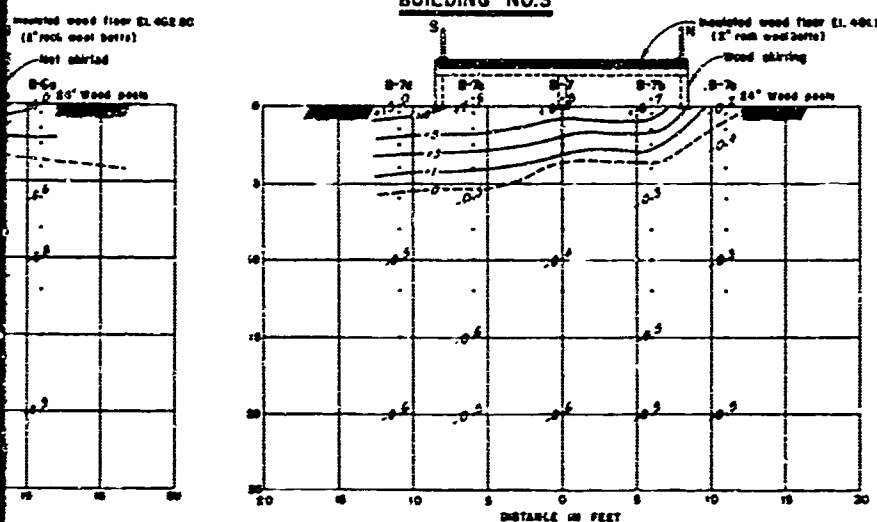

BUILDING NO. 7

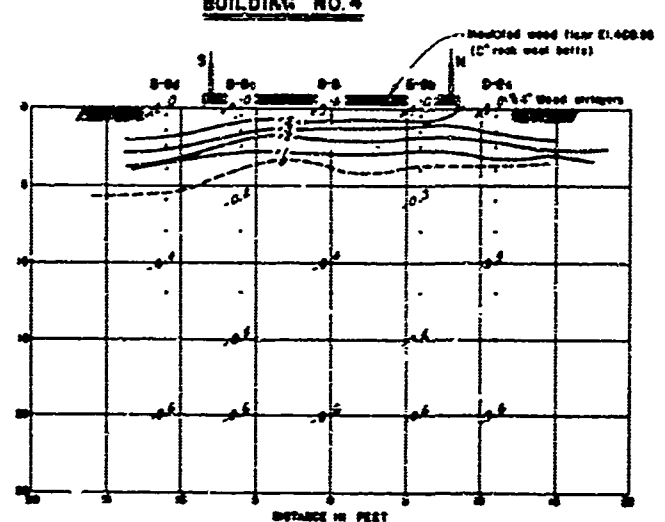

BUILDING NO. 8

B

Note:
 Boring locations shown on plate III-7
 Temperature observations shown
 in degrees centigrade
 - - - - Zero isotherm
 ——— Isotherms other than zero

**PERMAFROST INVESTIGATION
 FIELD RESEARCH
 FAIRBANKS, ALASKA
 AREA NO. 3
 GROUND TEMPERATURE OBSERVATIONS
 5 SEPTEMBER 1947**

SCALE AS SHOWN
 CORPS OF ENGINEERS ET AL., WASH. MAY 1948
 DRAWN BY P. G. STAGER I. P. G. CHECKED BY

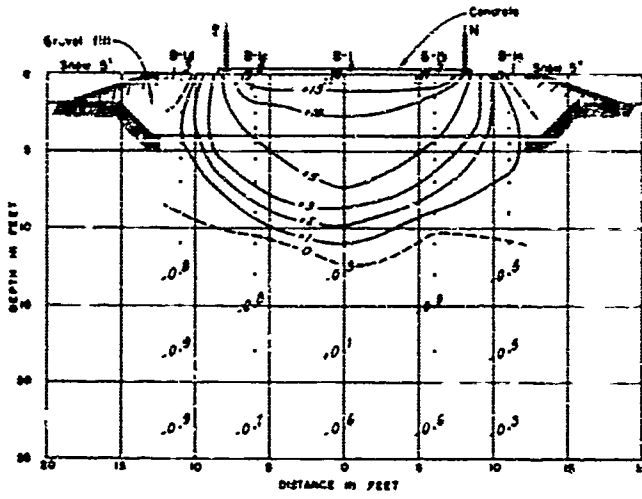

BUILDING NO. 1

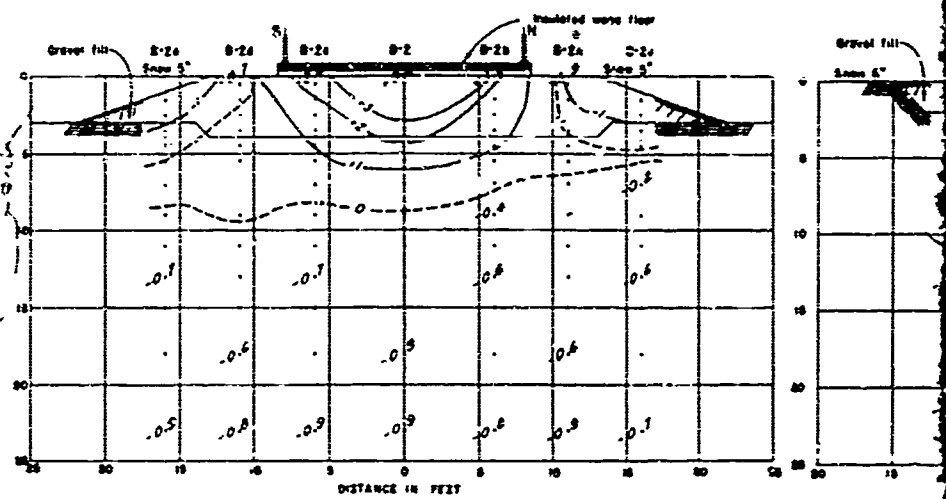

BUILDING NO. 2

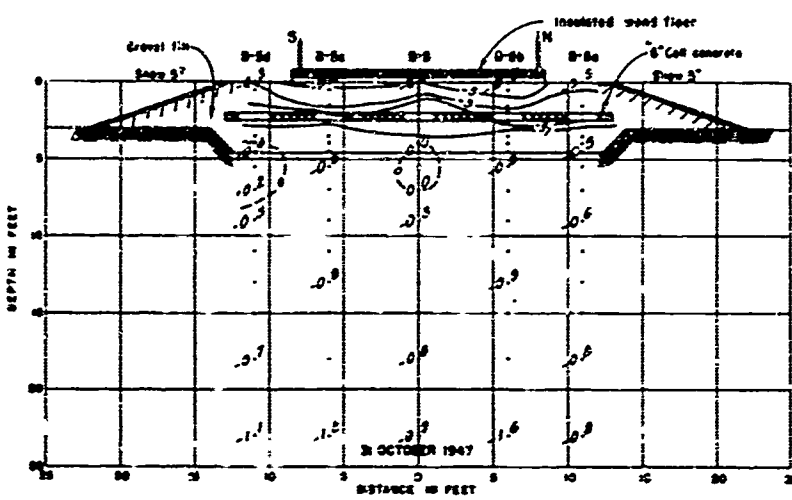

BUILDING NO. 5

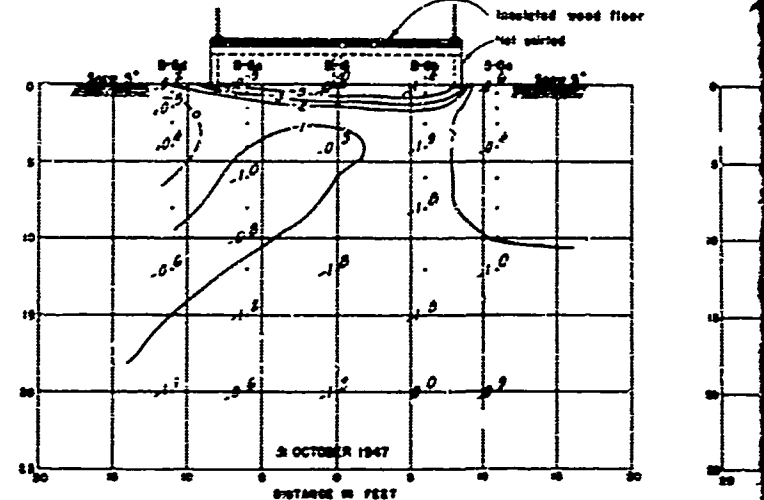

BUILDING NO. 6

A

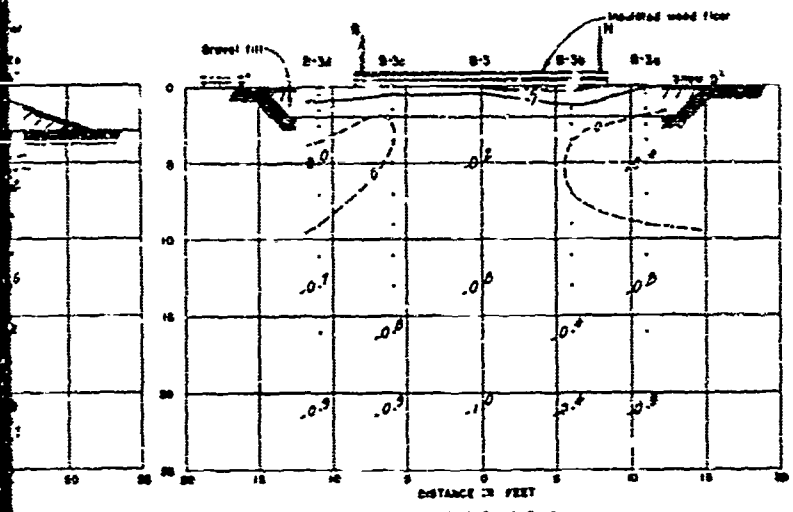

BUILDING NO. 3

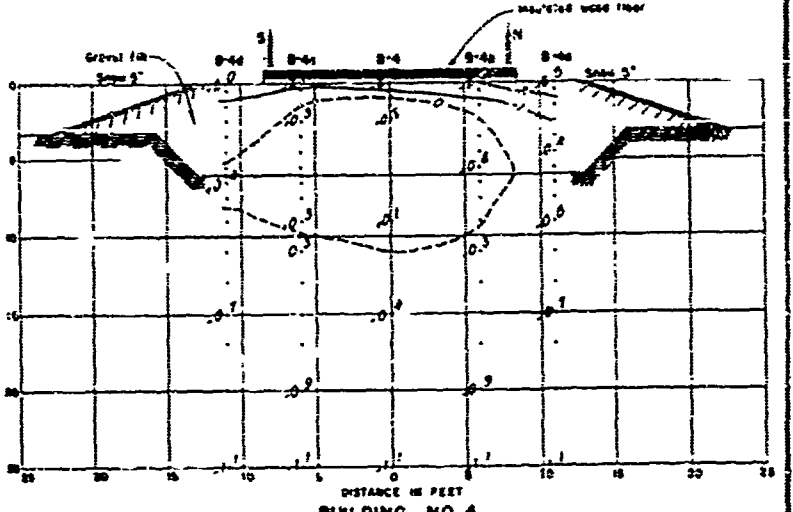

BUILDING NO. 4

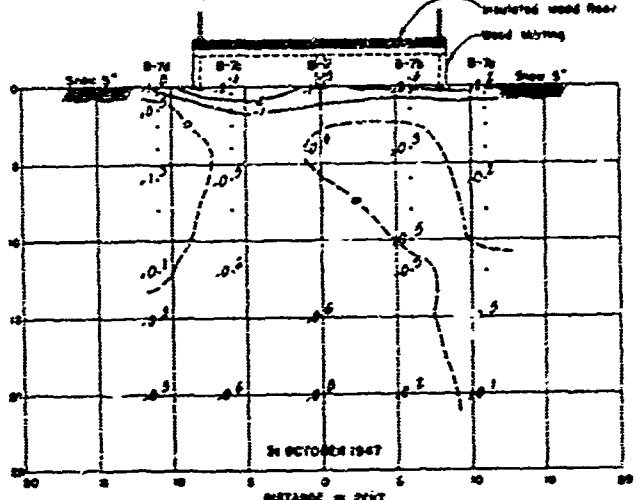
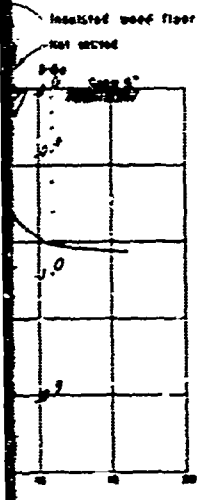

BUILDING NO. 7

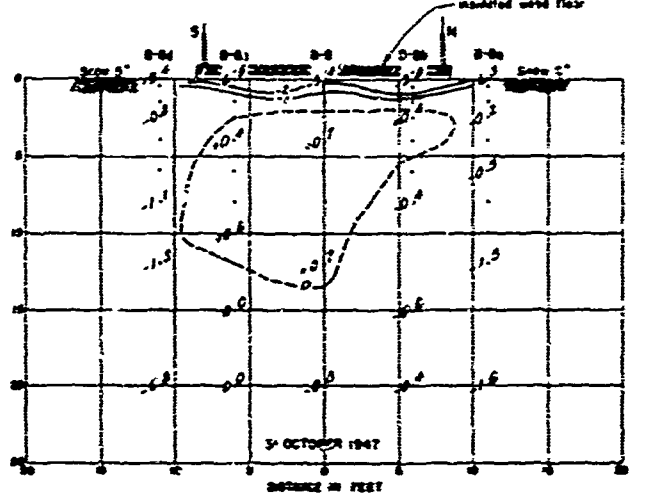

BUILDING NO. 8

B

Note.
 Bottom isotherm shown on plate III-7
 Temperature observations shown in
 degrees centigrade
 - - - - - Zero isotherm
 ——— Isotherms after they start

**PERMAFROST INVESTIGATION
 FIELD RESEARCH
 FAIRBANKS, ALASKA
 AREA NO. 3
 GROUND TEMPERATURE OBSERVATIONS
 30 OCTOBER 1947**

PLATE NO. 44
 CORPS OF ENGINEERS ST. PAUL, MINN. MAY 1947
 DRAWN BY P. P. B. TRACED BY P. P. B. CHECKED BY

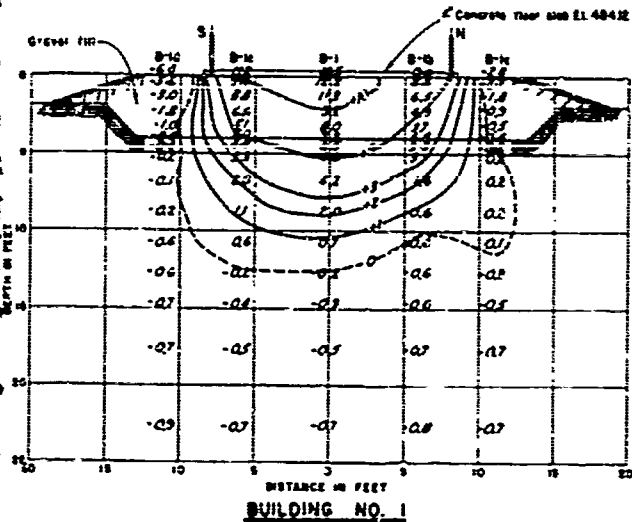

BUILDING NO. 1

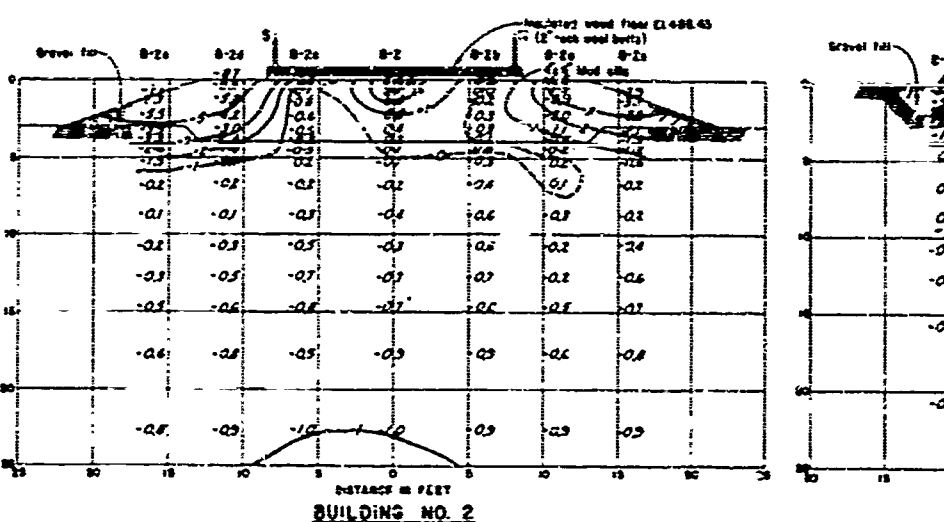

BUILDING NO. 2

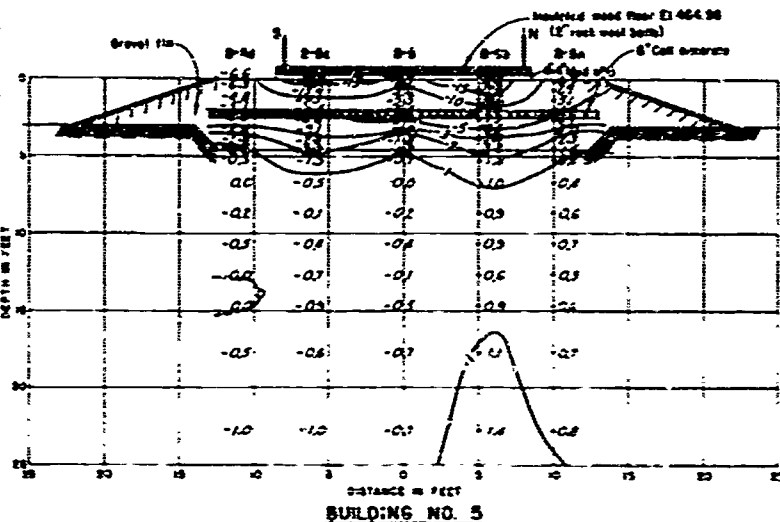

BUILDING NO. 3

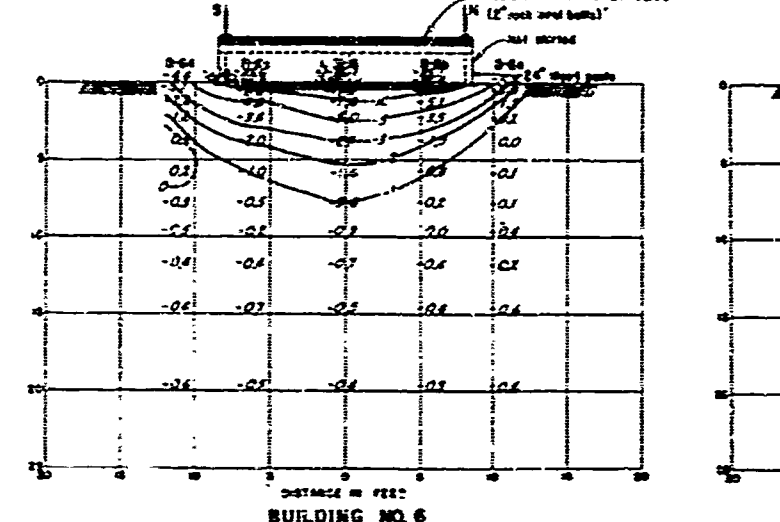

BUILDING NO. 6

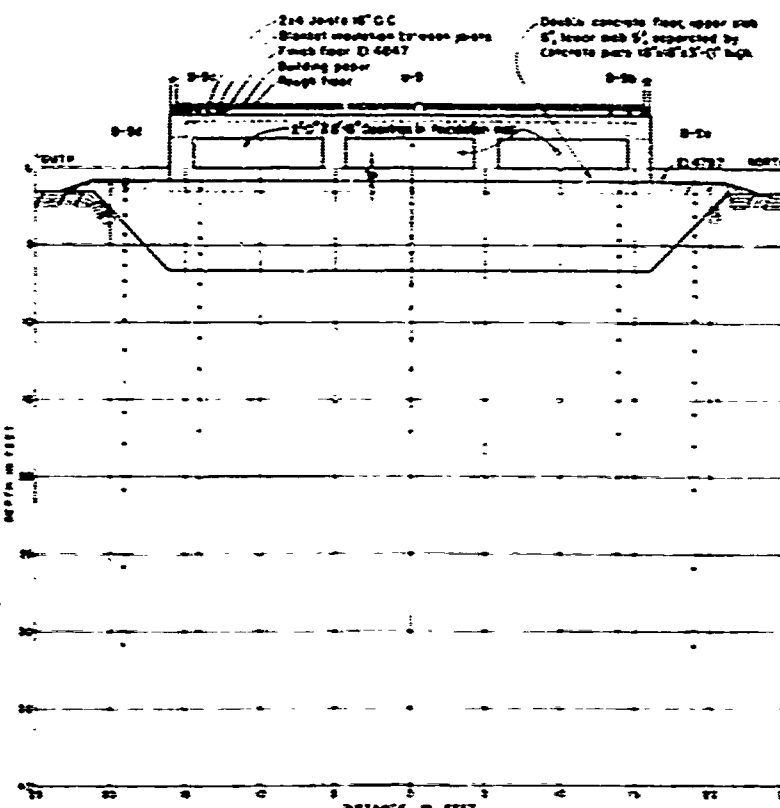

BUILDING NO. 8

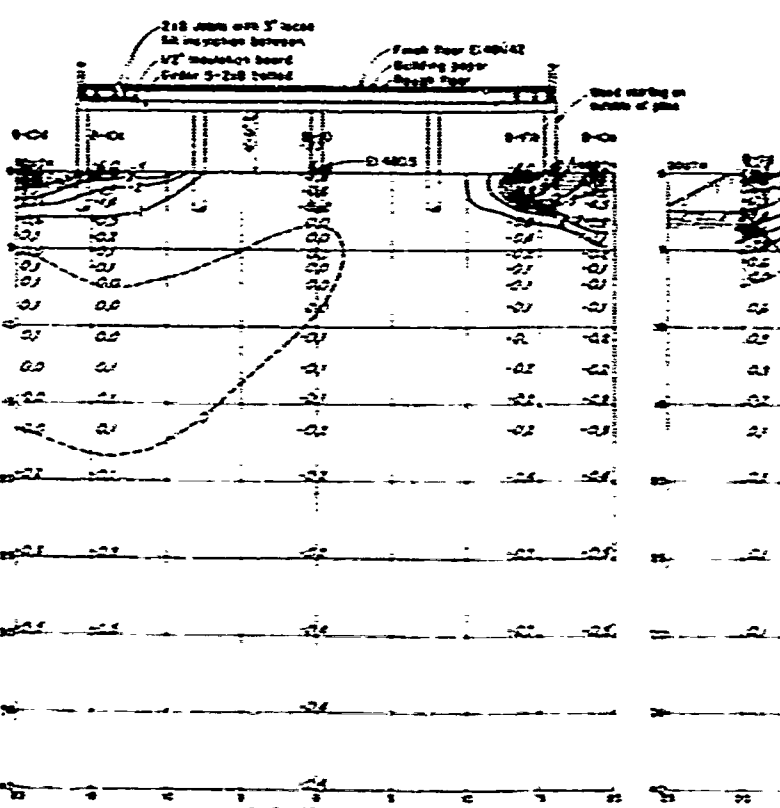

BUILDING NO. 10

A

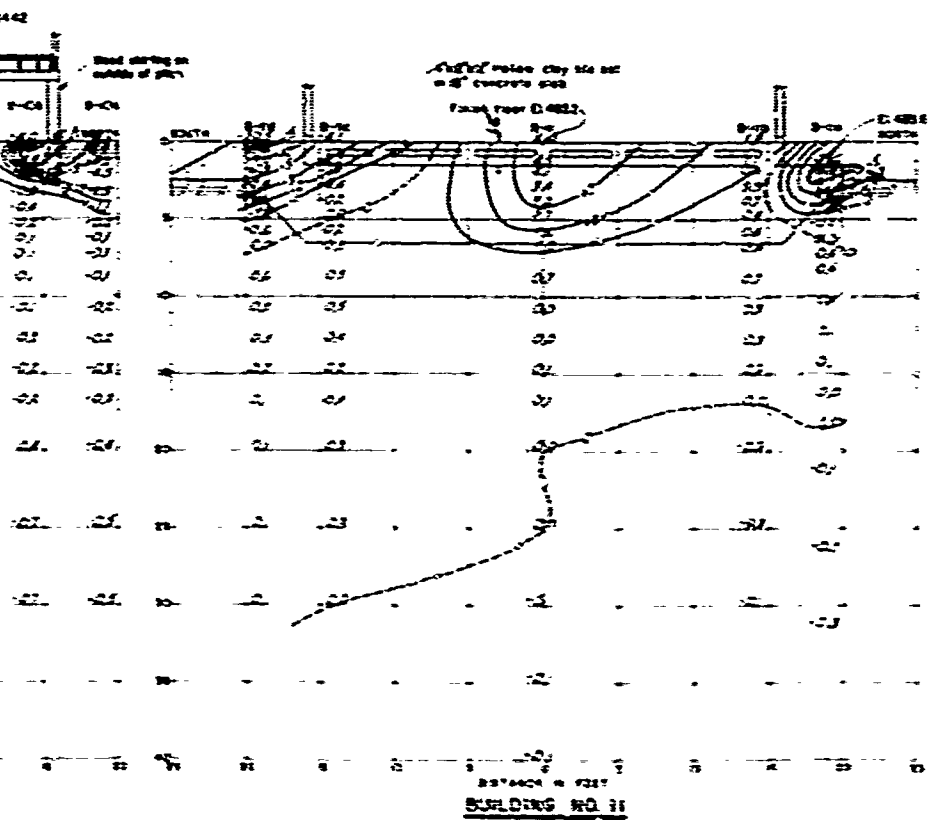
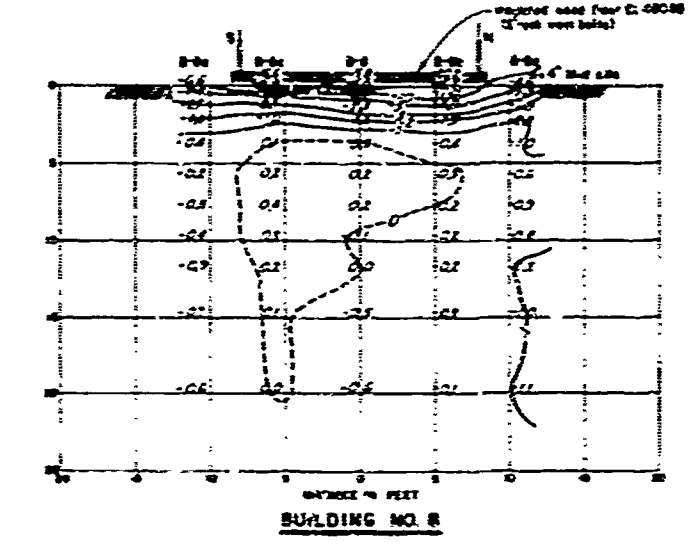
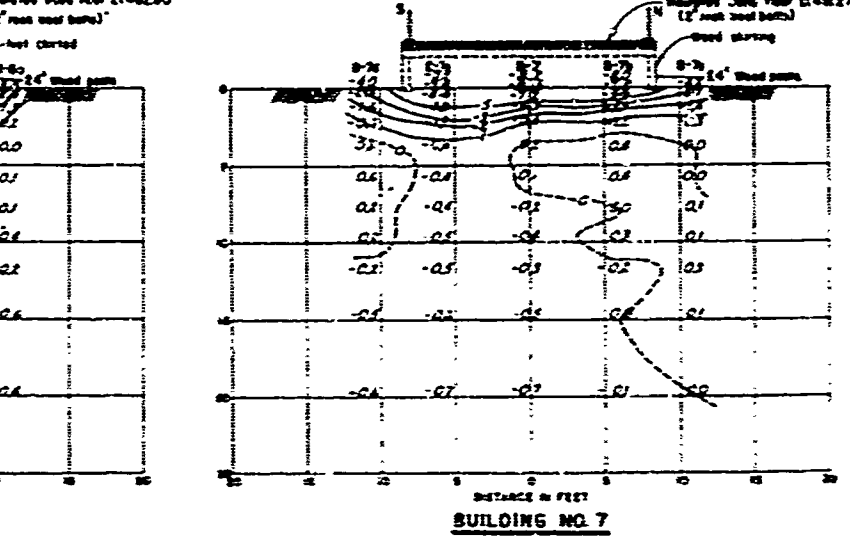
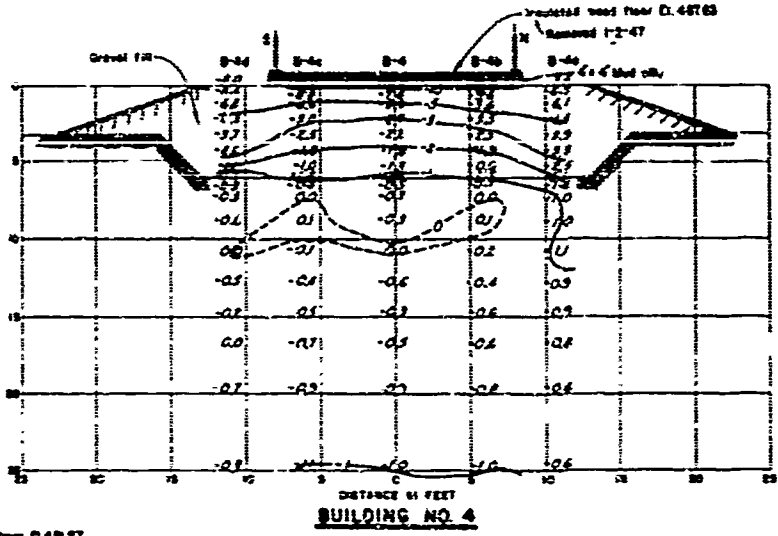
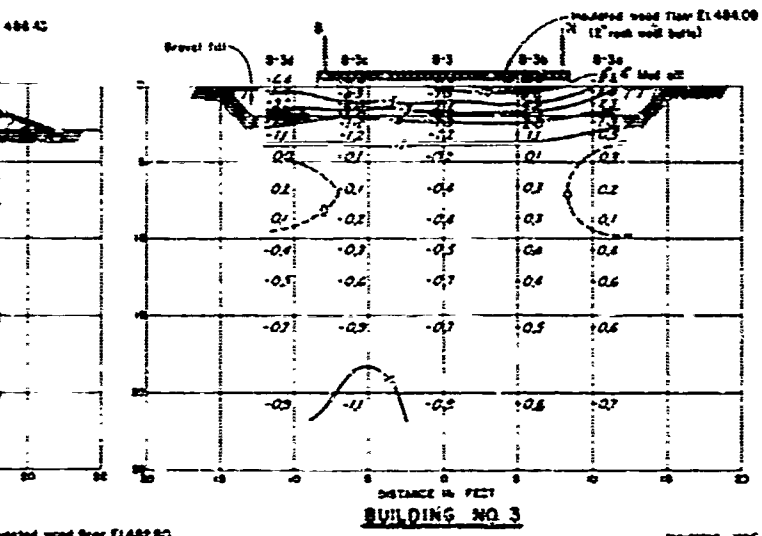

Note
 Building locations shown on plate III-7
 Temperature observations shown
 in degrees centigrade
 - - - - - Zero isotherm
 ———— Isotherm for other than zero

PERMAFROST INVESTIGATION
FIELD RESEARCH
FAIRBANKS, ALASKA
AREA NO. 3
GROUND TEMPERATURE OBSERVATIONS
1 FEBRUARY 1948

SCALE AS SHOWN
 COMPS OF ENGINEERS 57 PEARL BLVD. NEW YORK 100
 DRAWN BY P. H. GARDNER CHECKED BY P. H. GARDNER

B

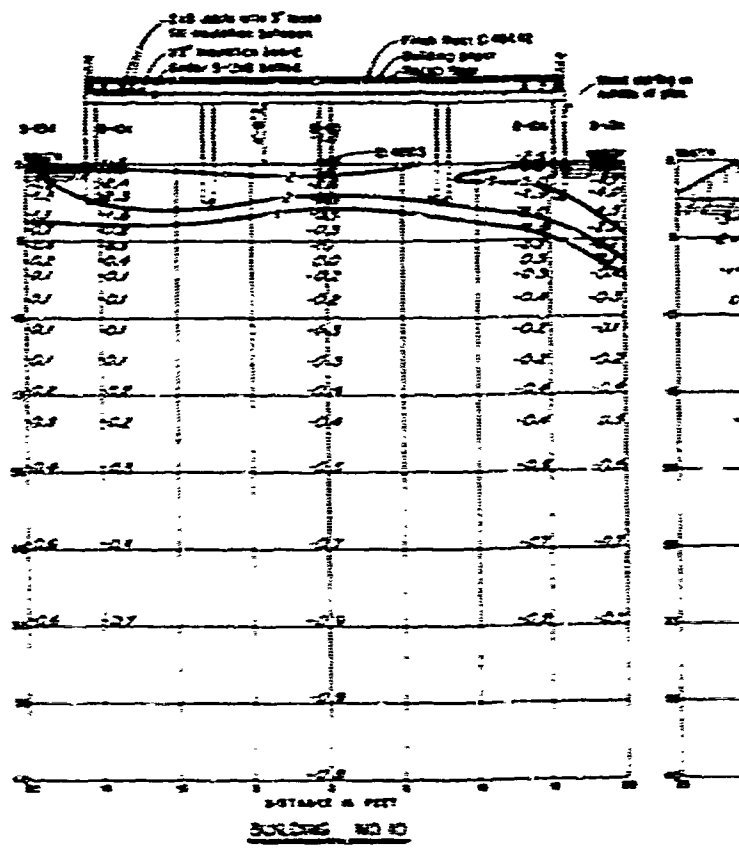
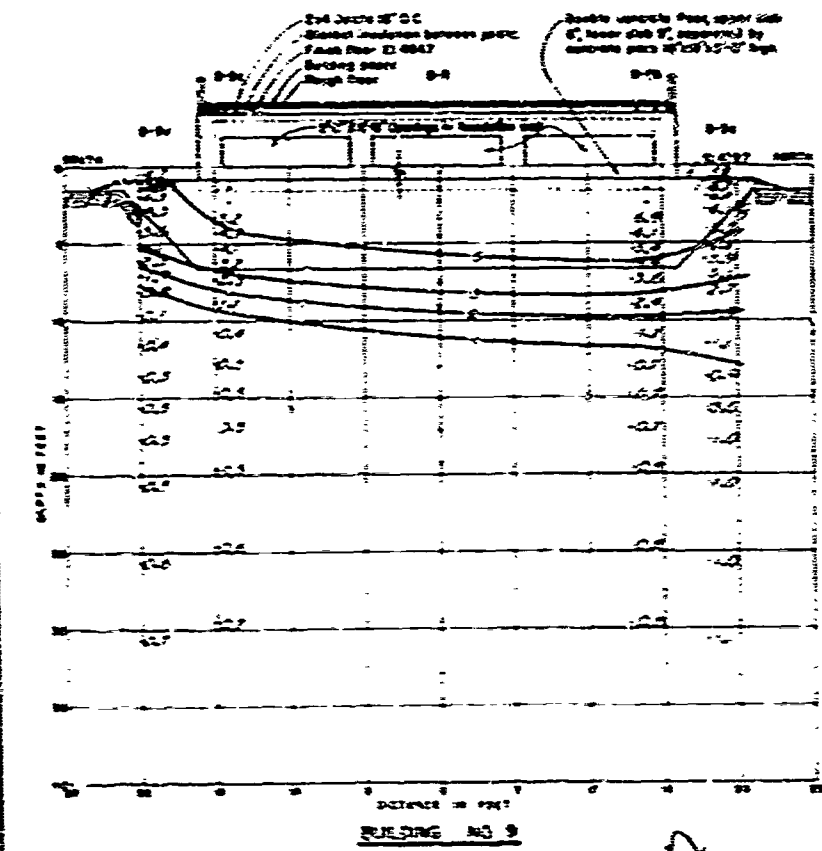
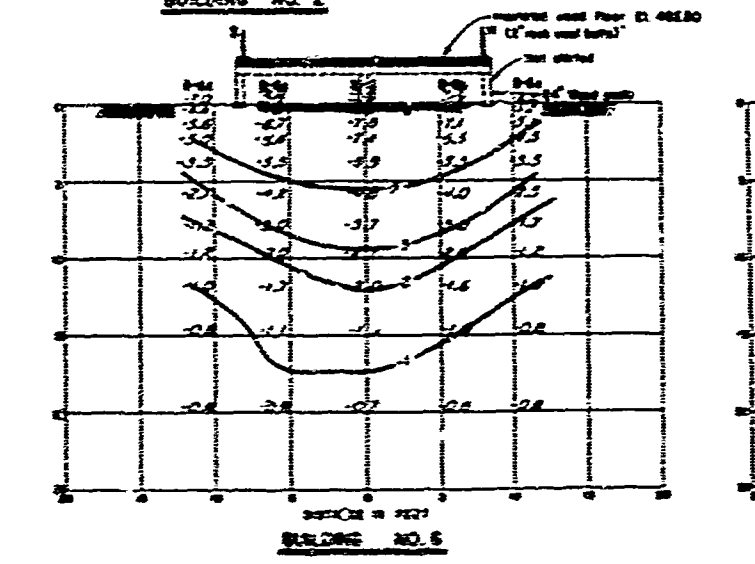
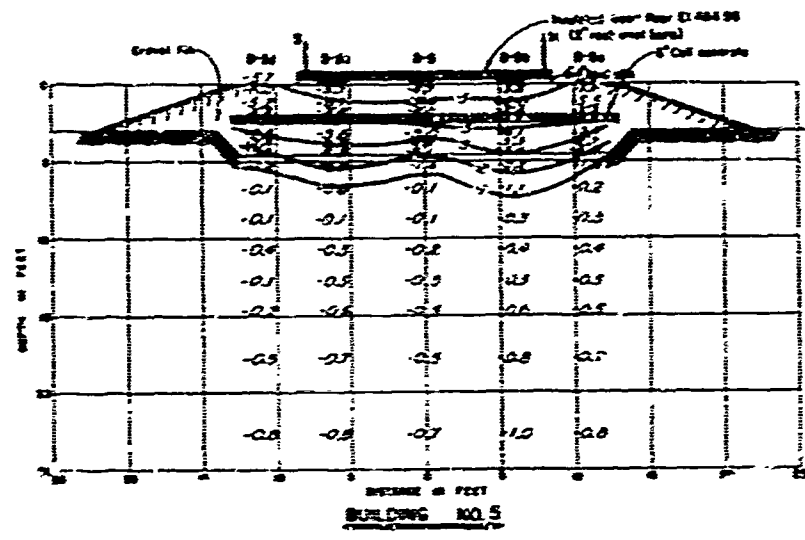
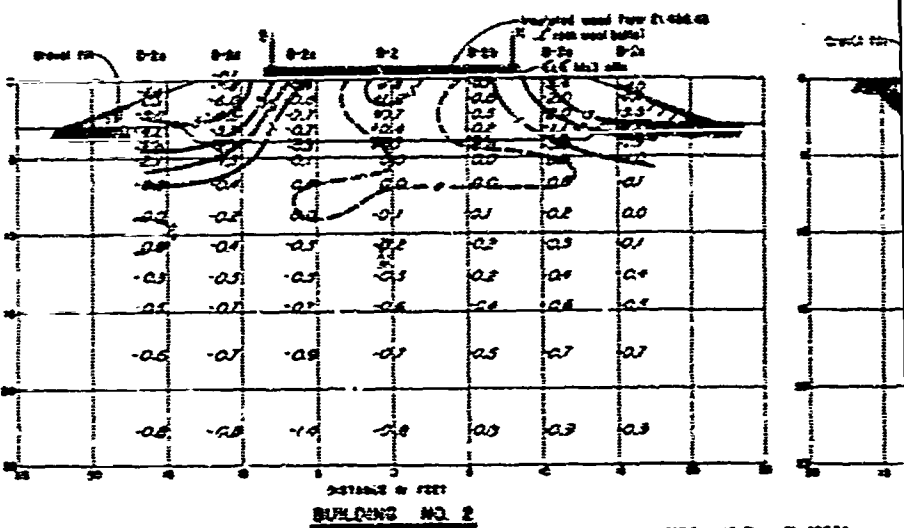
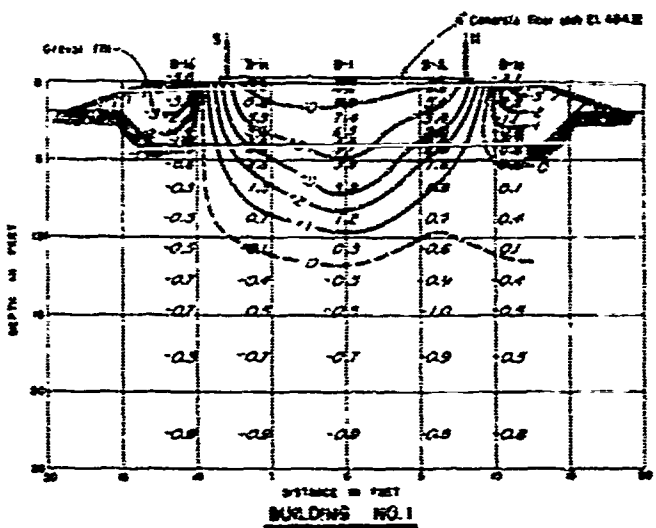

A

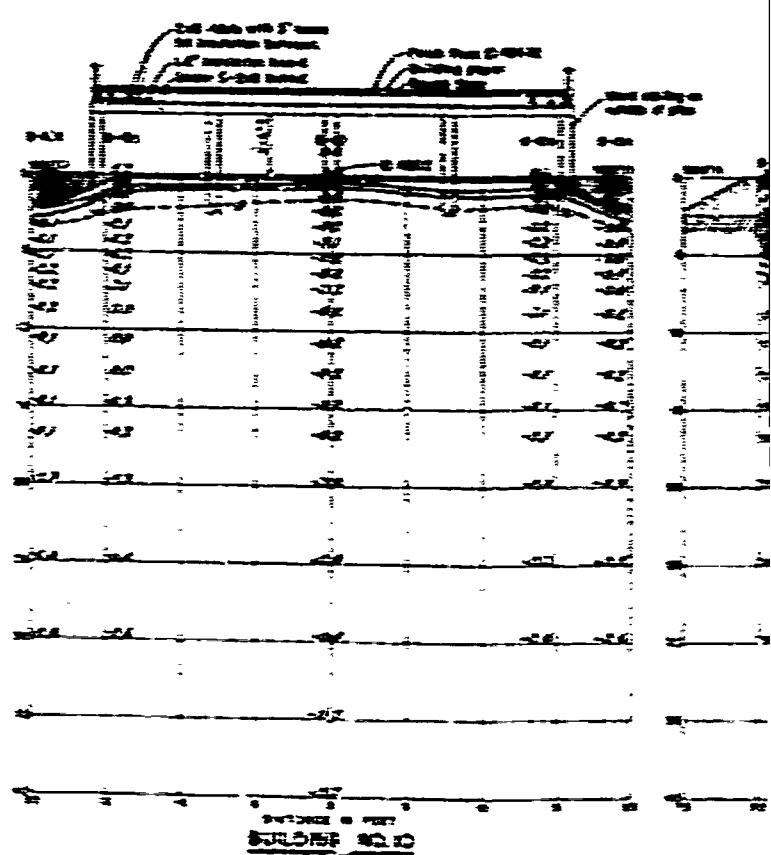
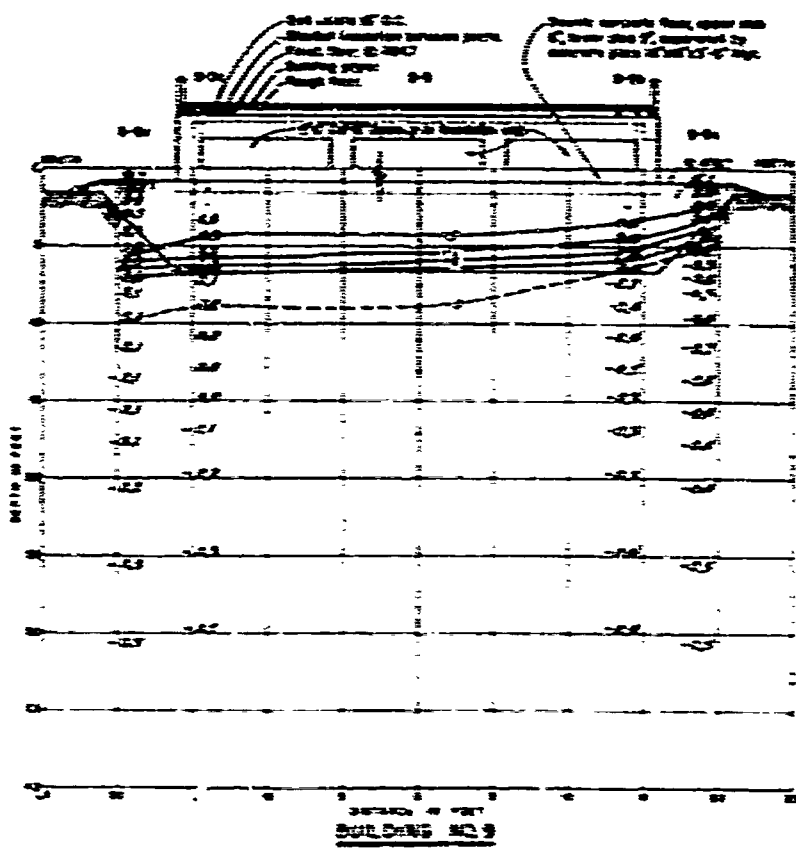
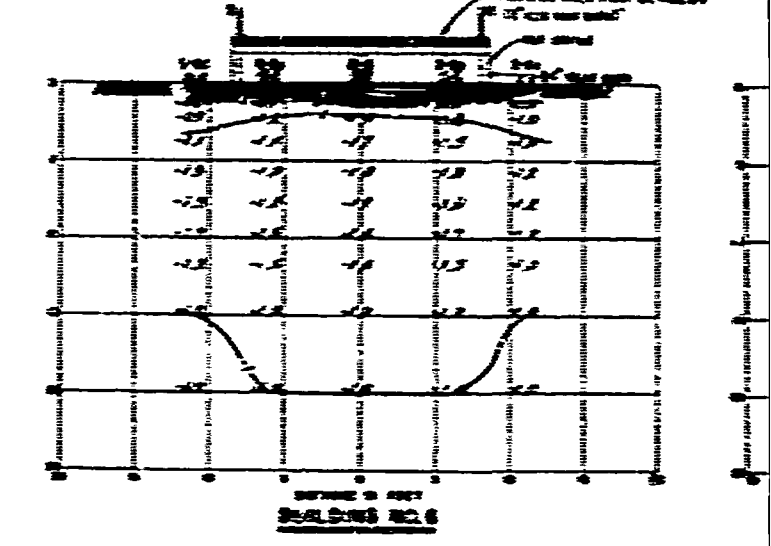
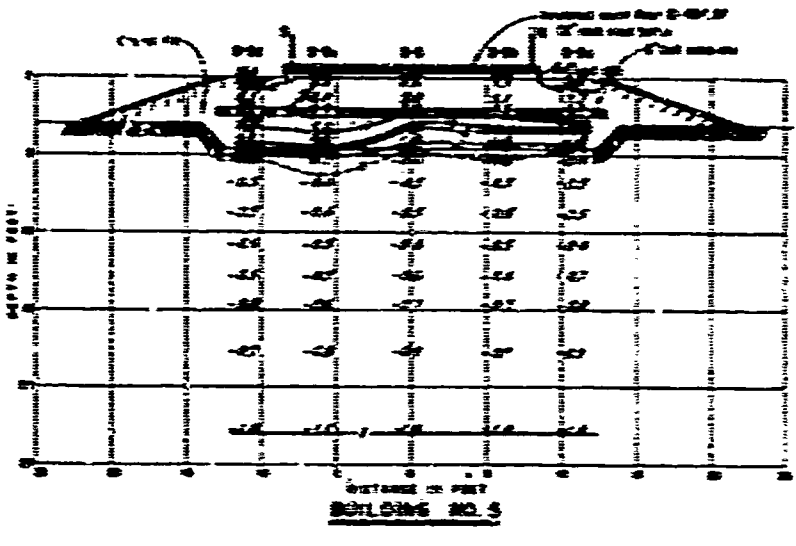
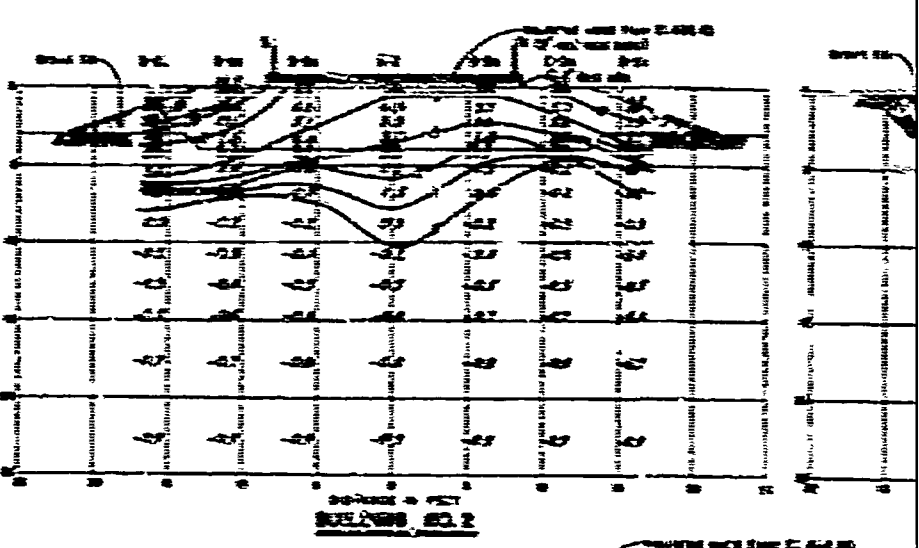
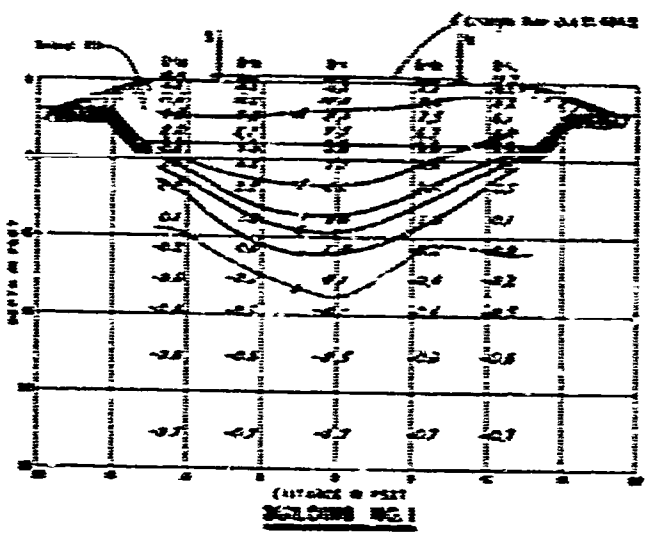

H

21-486.48

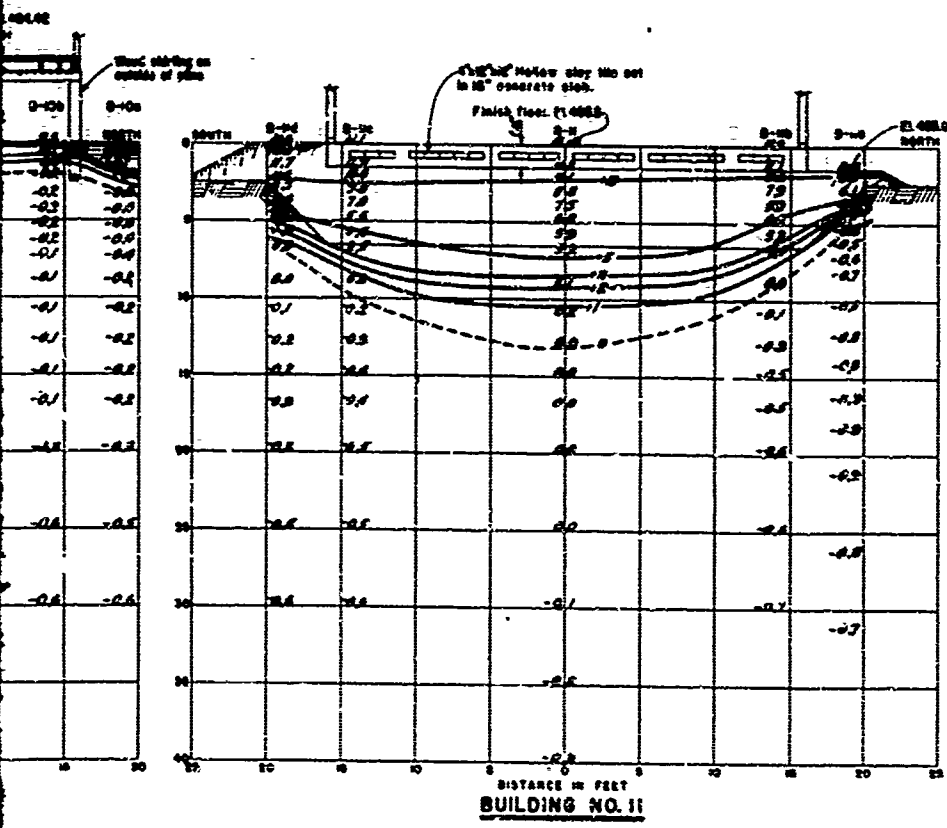
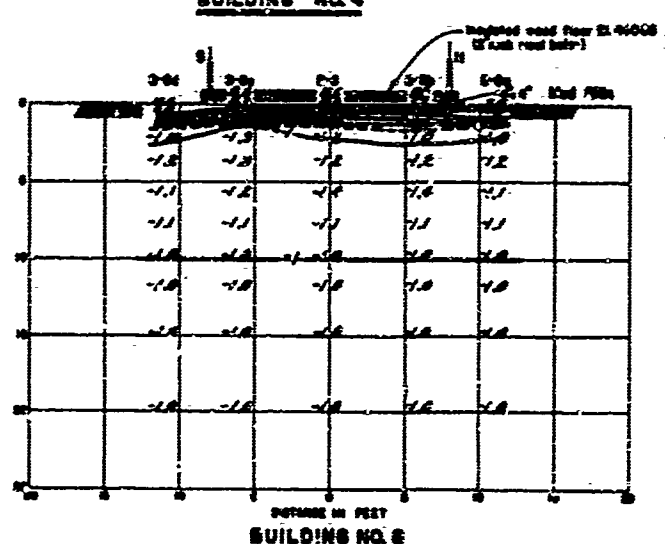
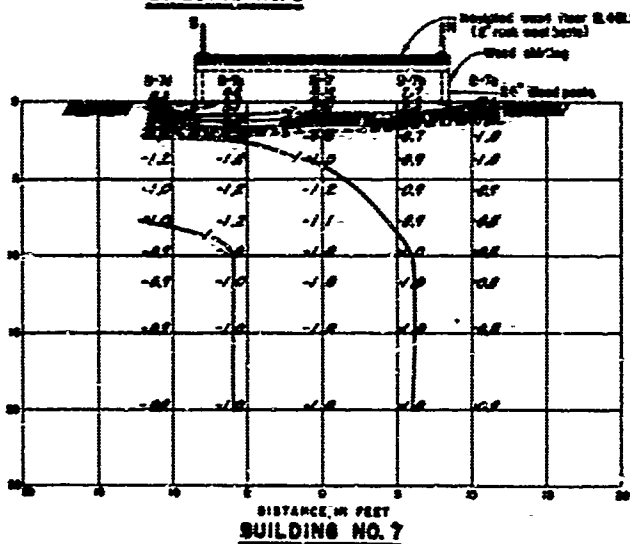
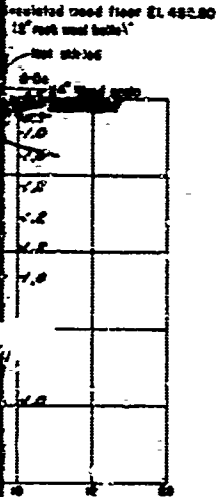
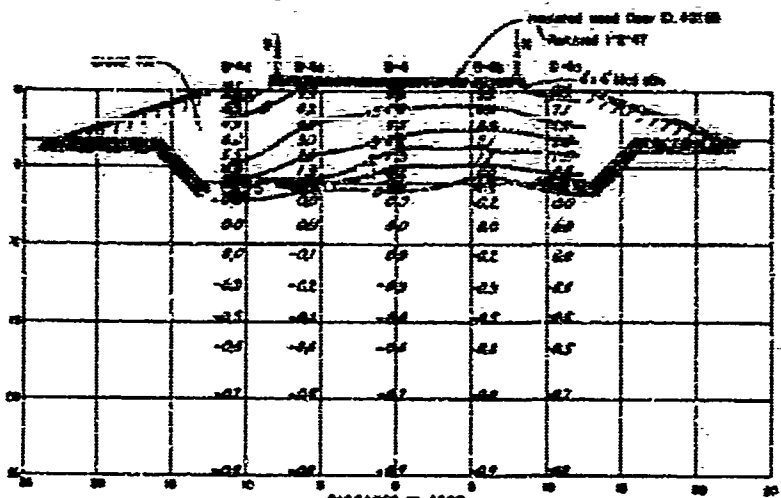
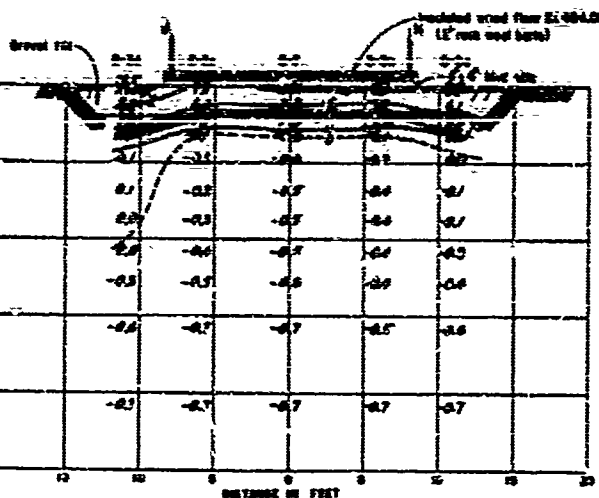

Note:
 Bulbing location shown on plate III-47
 Temperature observations shown
 in degrees centigrade.
 - - - Zero isotherm
 — Isotherms other than zero.

PERMAFROST INVESTIGATION
FIELD RESEARCH
FAIRBANKS, ALASKA
AREA NO. 3
GROUND TEMPERATURE OBSERVATIONS
5 JUNE 1948

SCALE AS SHOWN
 CORPS OF ENGINEERS ST. PAUL, MINN. MAY 1930
 DRAWN BY R. P. TRACER BY B. B. CHAS. 28 87

B

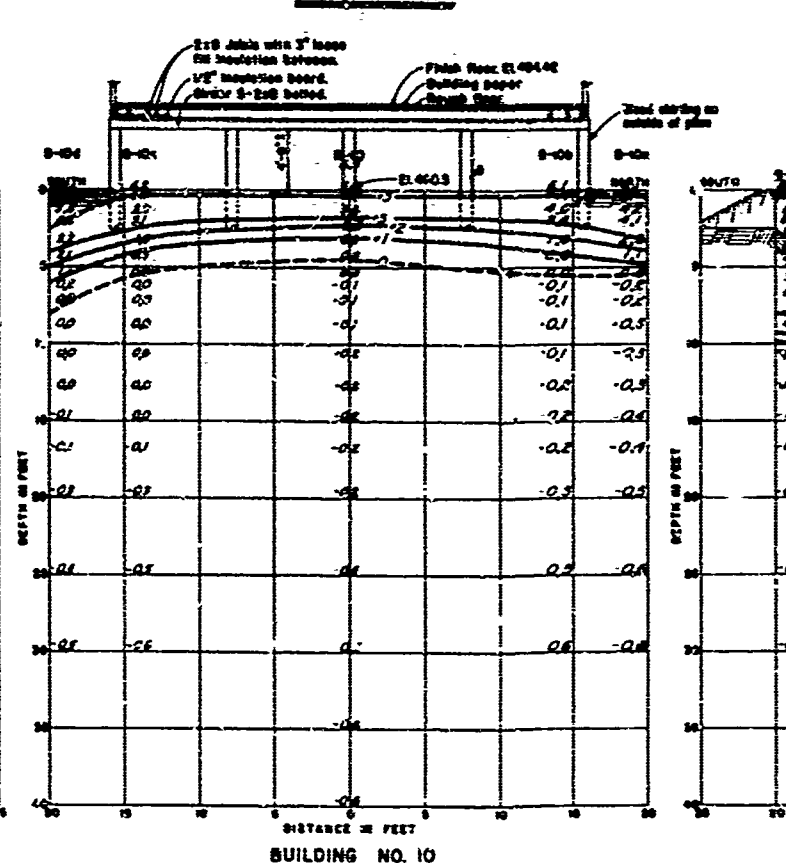
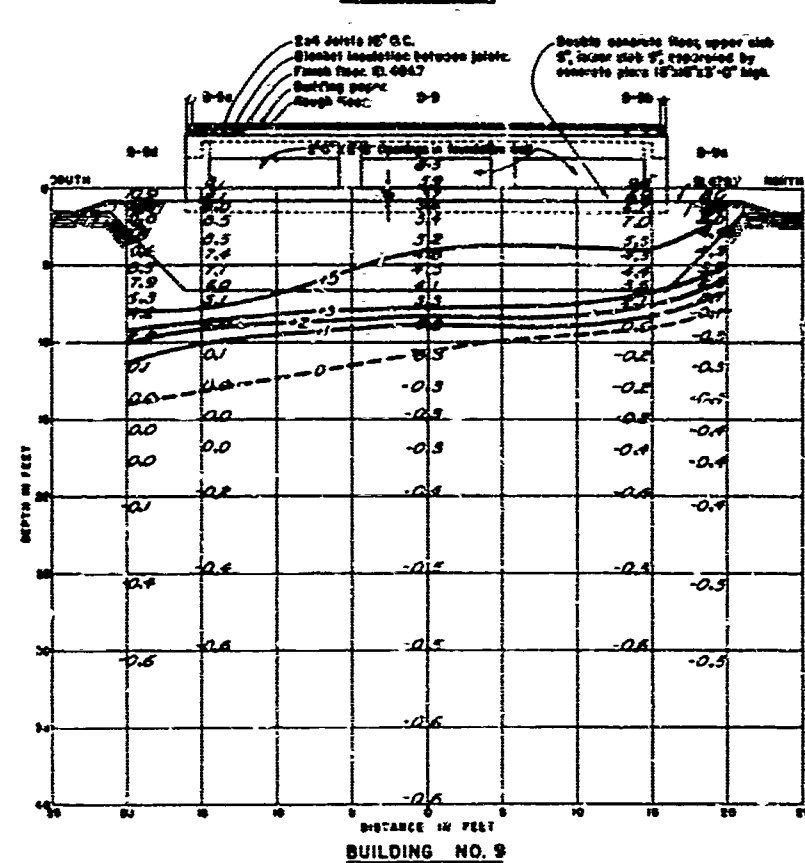
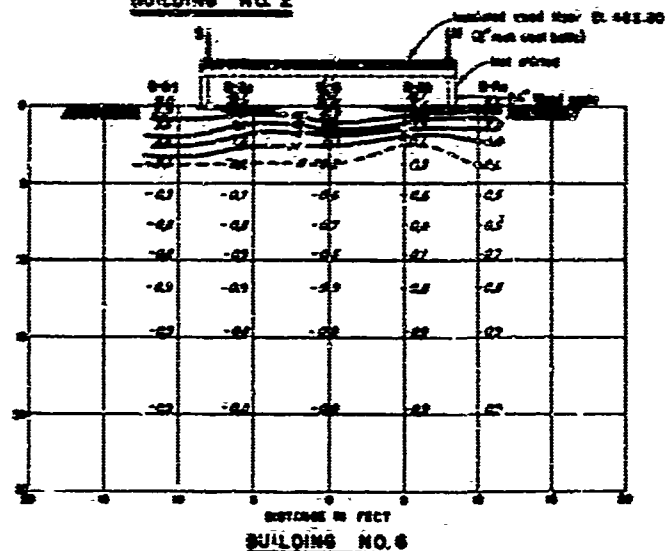
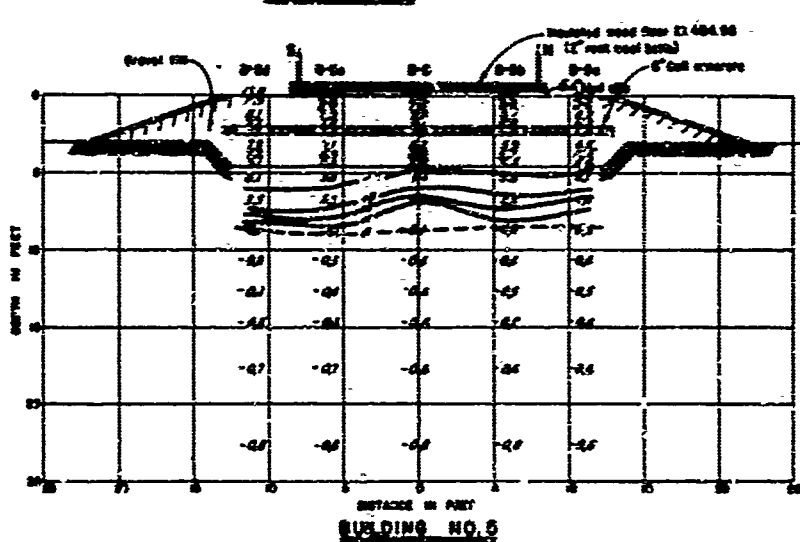
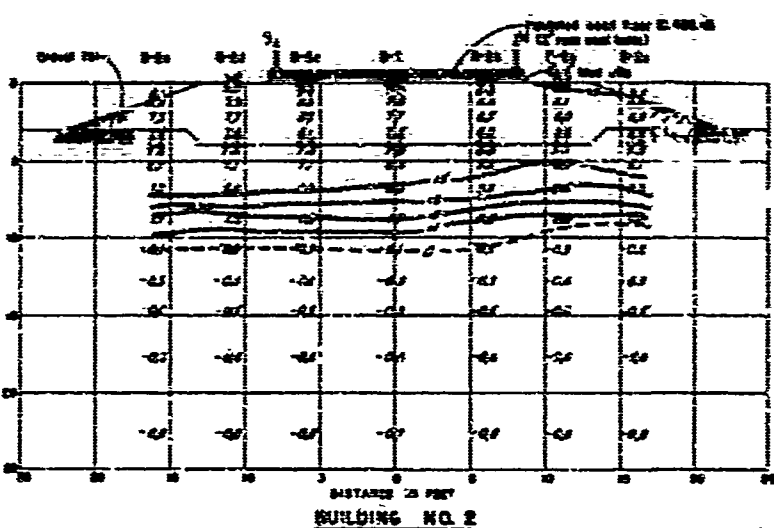
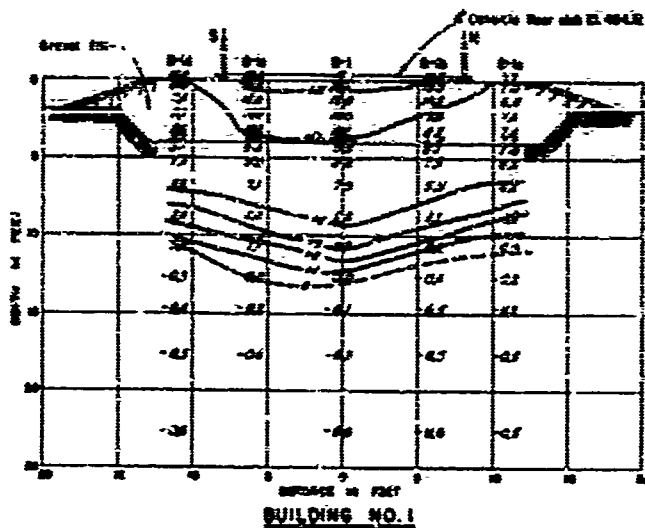

A

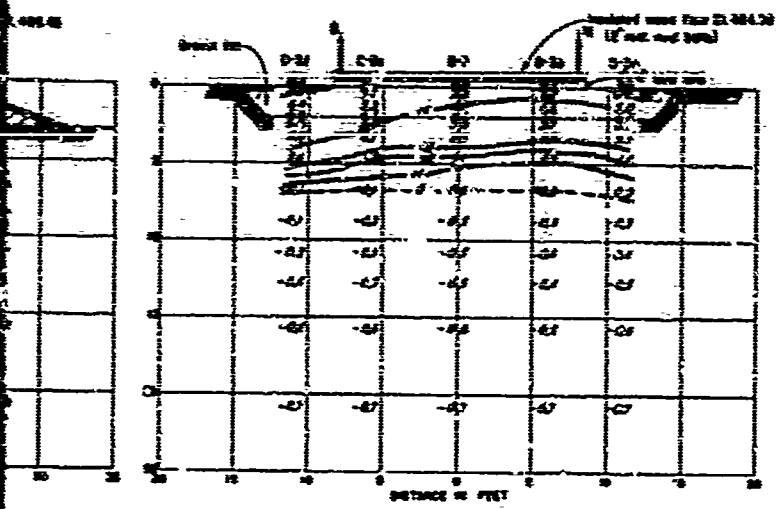

BUILDING NO. 3

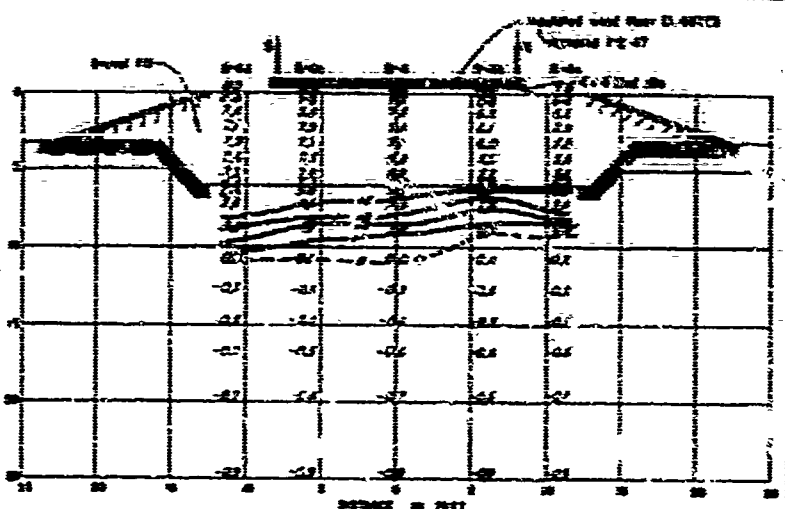

BUILDING NO. 4

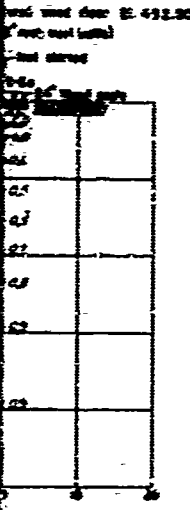

BUILDING NO. 7

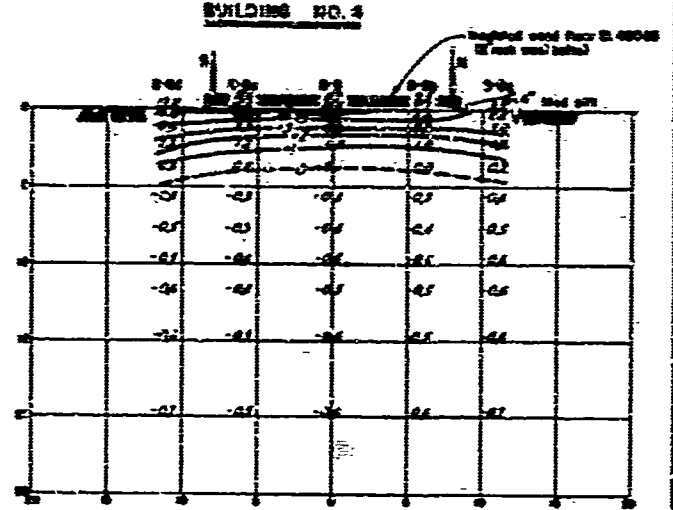

BUILDING NO. 8

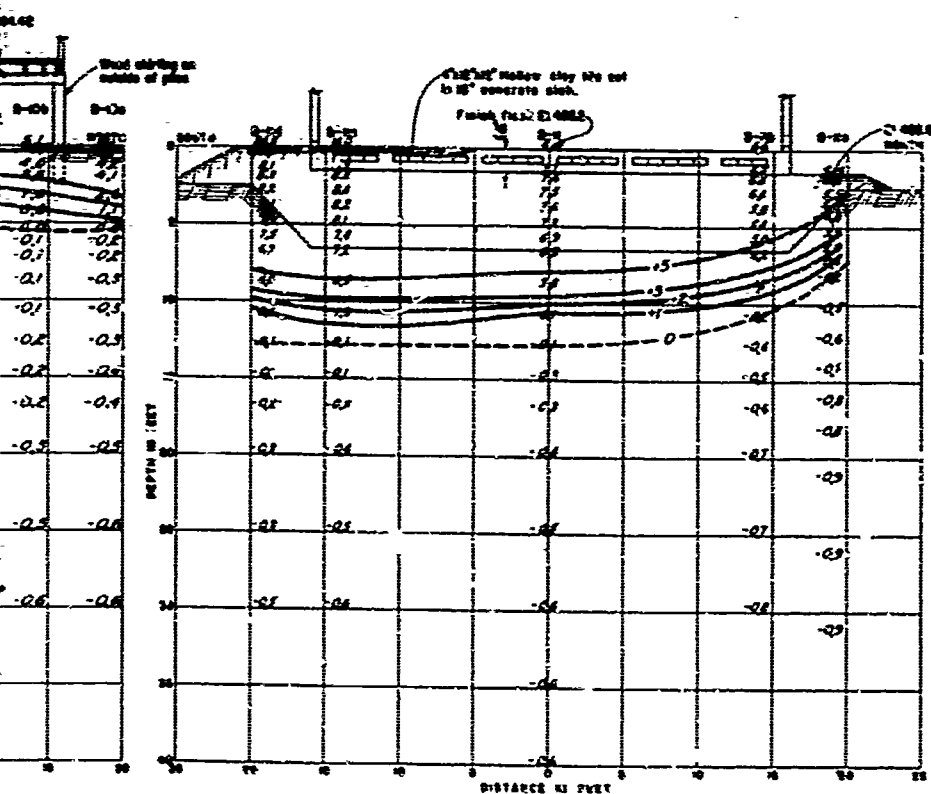

BUILDING NO. 11

Note:
 Building location shown on plate XII-7
 Temperature observations shown
 in degrees centigrade.
 --- Zero isotherm.
 — Isotherms other than zero.

PERMAFROST INVESTIGATION
 FIELD RESEARCH
 FAIRBANKS, ALASKA
 AREA NO. 3
 GROUND TEMPERATURE OBSERVATIONS
 5 SEPTEMBER 1948

SCALE AS SHOWN
 CORPS OF ENGINEERS ST. PAUL, MINN. MAY 1940
 DRAWN BY P.P.B. TRACED BY S.P.B. CHECKED BY

A

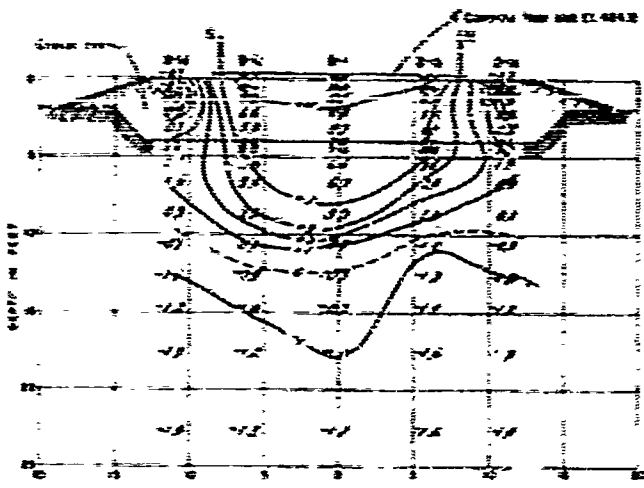

BUILDING NO. 1

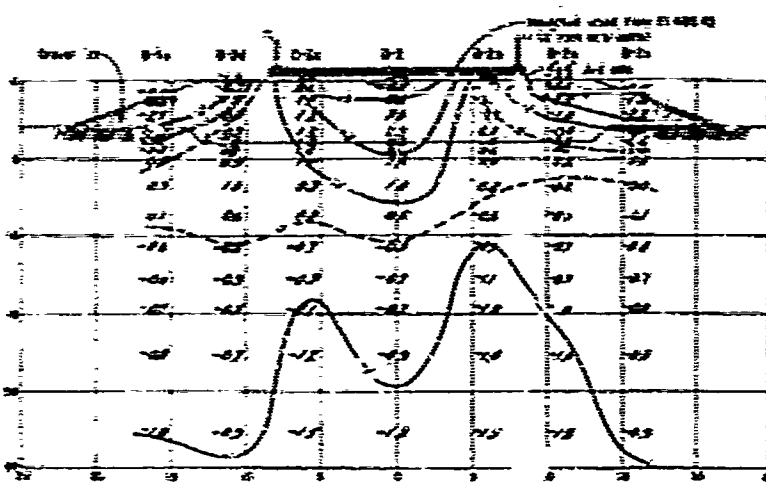

BUILDING NO. 2

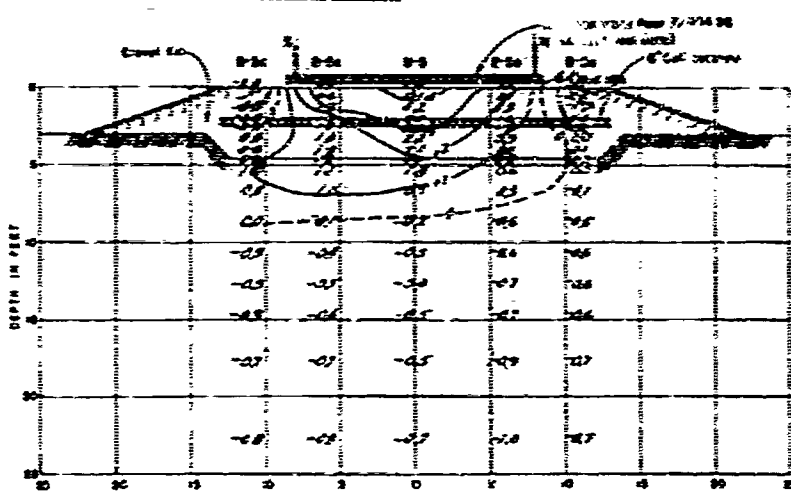

BUILDING NO. 5

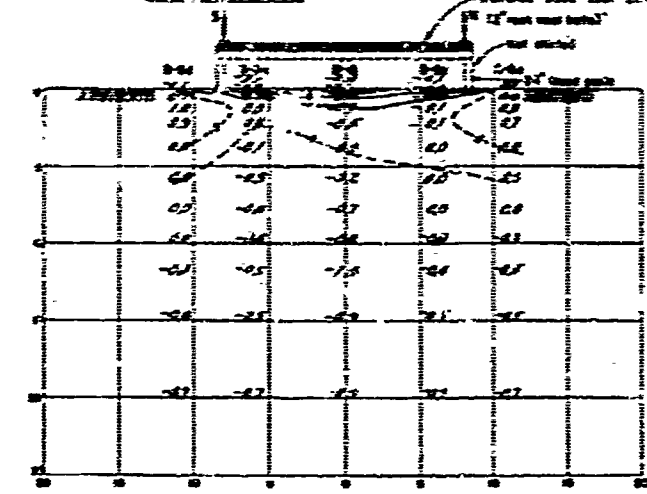

BUILDING NO. 6

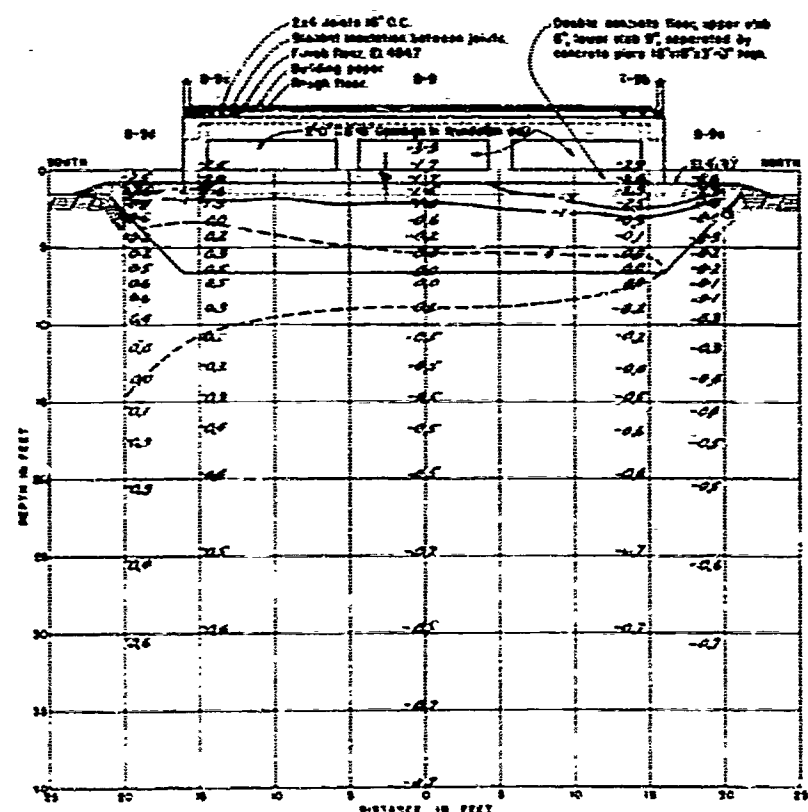

BUILDING NO. 9

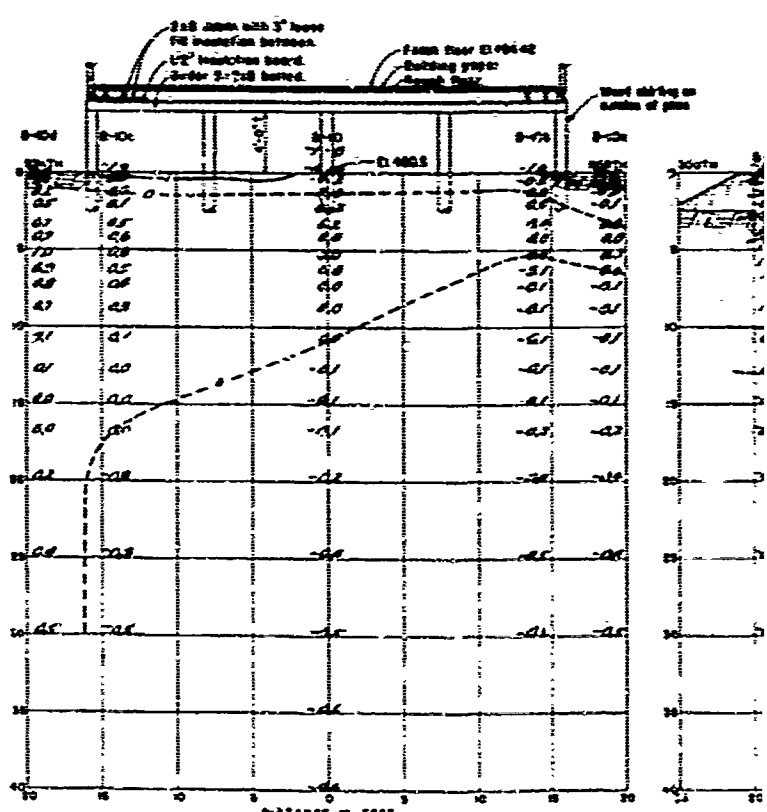

BUILDING NO. 10

A

2442

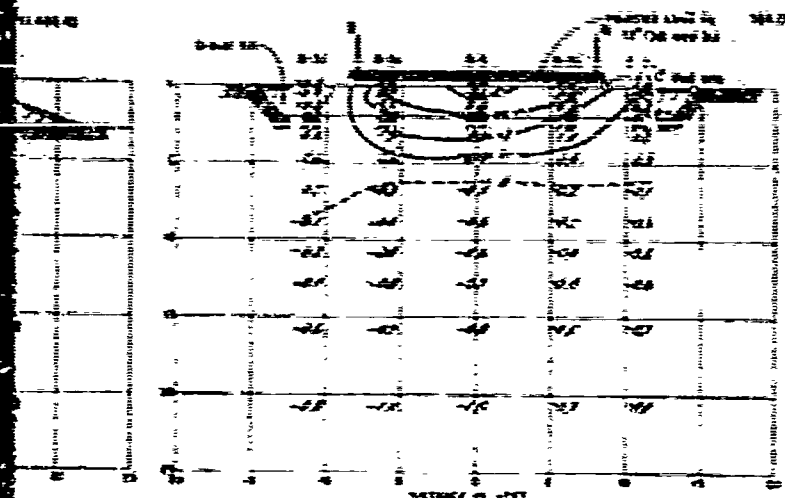

BUILDING NO. 3

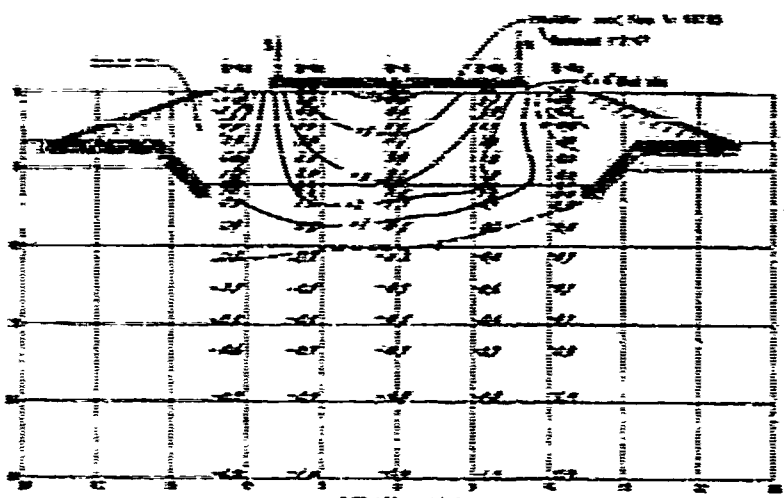

BUILDING NO. 4

Notes:

- 1. All temperatures are in degrees Celsius.
- 2. All temperatures are at the same time.
- 3. All temperatures are at the same place.
- 4. All temperatures are at the same depth.
- 5. All temperatures are at the same distance.
- 6. All temperatures are at the same building.
- 7. All temperatures are at the same location.
- 8. All temperatures are at the same time of day.
- 9. All temperatures are at the same time of year.
- 10. All temperatures are at the same time of month.
- 11. All temperatures are at the same time of week.
- 12. All temperatures are at the same time of day of the week.
- 13. All temperatures are at the same time of day of the month.
- 14. All temperatures are at the same time of day of the year.
- 15. All temperatures are at the same time of day of the month of the year.
- 16. All temperatures are at the same time of day of the month of the year of the day.
- 17. All temperatures are at the same time of day of the month of the year of the day of the month.
- 18. All temperatures are at the same time of day of the month of the year of the day of the month of the year.
- 19. All temperatures are at the same time of day of the month of the year of the day of the month of the year of the day.
- 20. All temperatures are at the same time of day of the month of the year of the day of the month of the year of the day of the month.

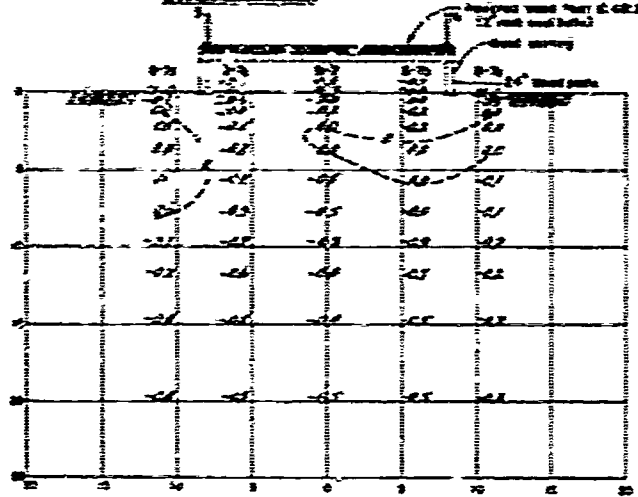

BUILDING NO. 7

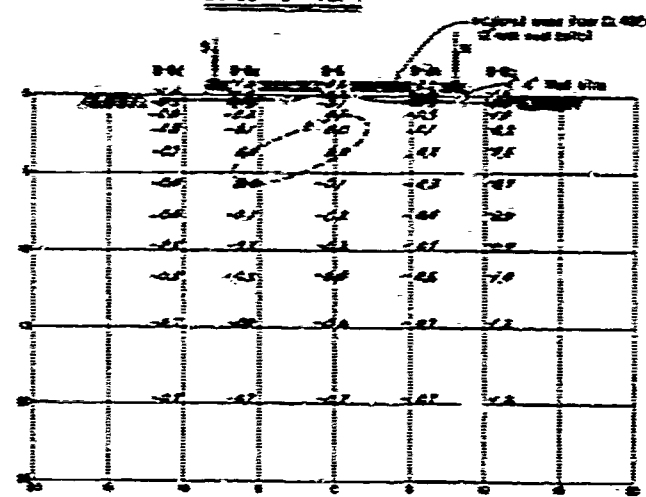

BUILDING NO. 8

2442

Notes:

- 1. All temperatures are in degrees Celsius.
- 2. All temperatures are at the same time.
- 3. All temperatures are at the same place.
- 4. All temperatures are at the same depth.
- 5. All temperatures are at the same distance.
- 6. All temperatures are at the same building.
- 7. All temperatures are at the same location.
- 8. All temperatures are at the same time of day.
- 9. All temperatures are at the same time of year.
- 10. All temperatures are at the same time of month.
- 11. All temperatures are at the same time of week.
- 12. All temperatures are at the same time of day of the week.
- 13. All temperatures are at the same time of day of the month.
- 14. All temperatures are at the same time of day of the year.
- 15. All temperatures are at the same time of day of the month of the year.
- 16. All temperatures are at the same time of day of the month of the year of the day.
- 17. All temperatures are at the same time of day of the month of the year of the day of the month.
- 18. All temperatures are at the same time of day of the month of the year of the day of the month of the year.
- 19. All temperatures are at the same time of day of the month of the year of the day of the month of the year of the day.
- 20. All temperatures are at the same time of day of the month of the year of the day of the month of the year of the day of the month.

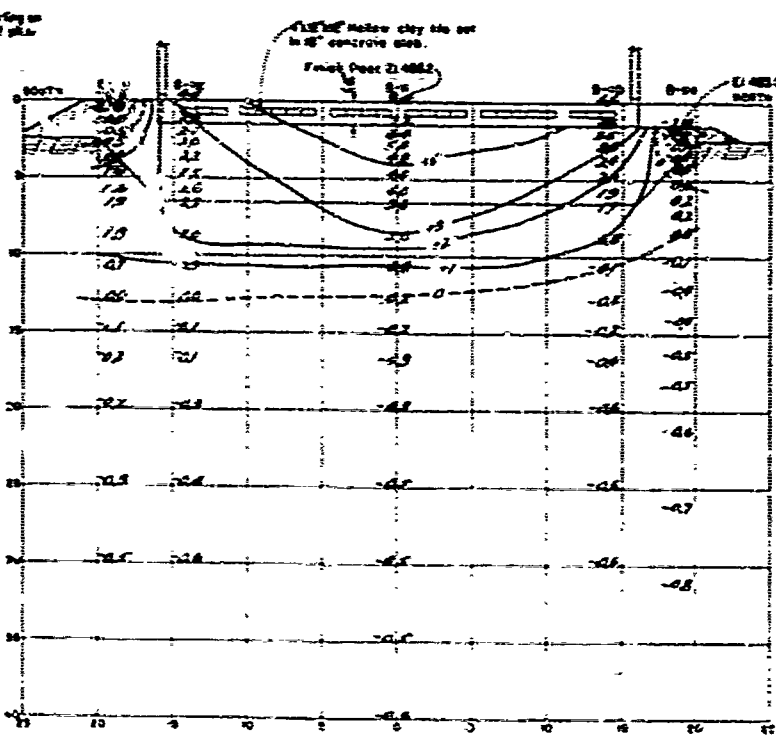

BUILDING NO. 11

Note:
 Building locations shown on plate III-7
 Temperature observations shown
 in degrees centigrade.
 — Zero isotherm
 — Isotherms other than zero.

PERMAFROST INVESTIGATION
FIELD RESEARCH
FAIRBANKS, ALASKA
AREA NO. 3
GROUND TEMPERATURE OBSERVATIONS
30 OCTOBER 1948

SCALE AS SHOWN
 CORPS OF ENGINEERS ST. PAUL, MINN. MAY 1950
 DRAWN BY S.P.L. TRACED BY S.P.S. CHECKED BY

B

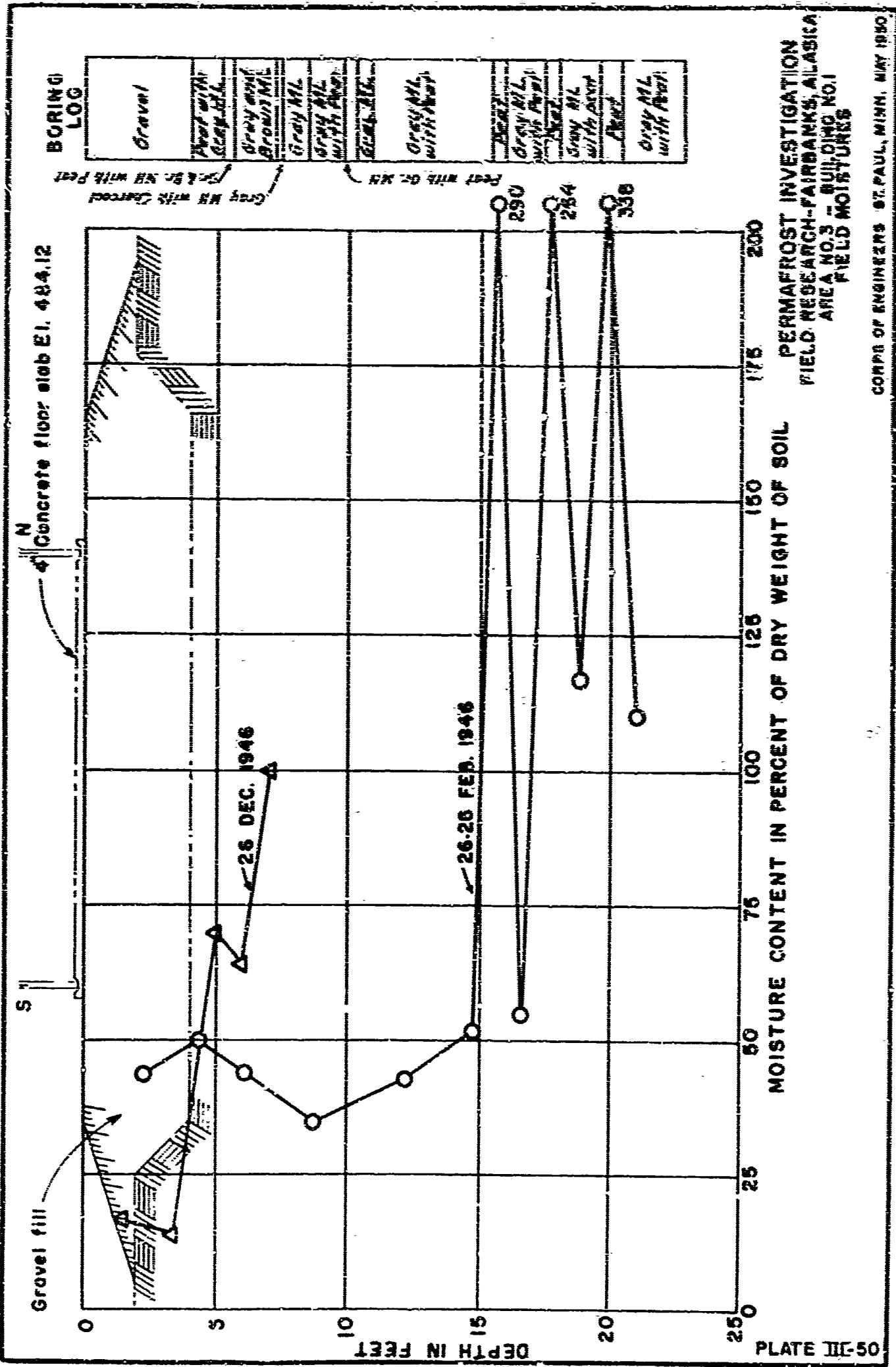

PERMAFROST INVESTIGATION
 FIELD RESEARCH-FAIRBANKS, ALASKA
 AREA NO. 3 - BUILDING NO. 1
 FIELD MOISTURES

CORPS OF ENGINEERS ST. PAUL, MINN. MAY 1950

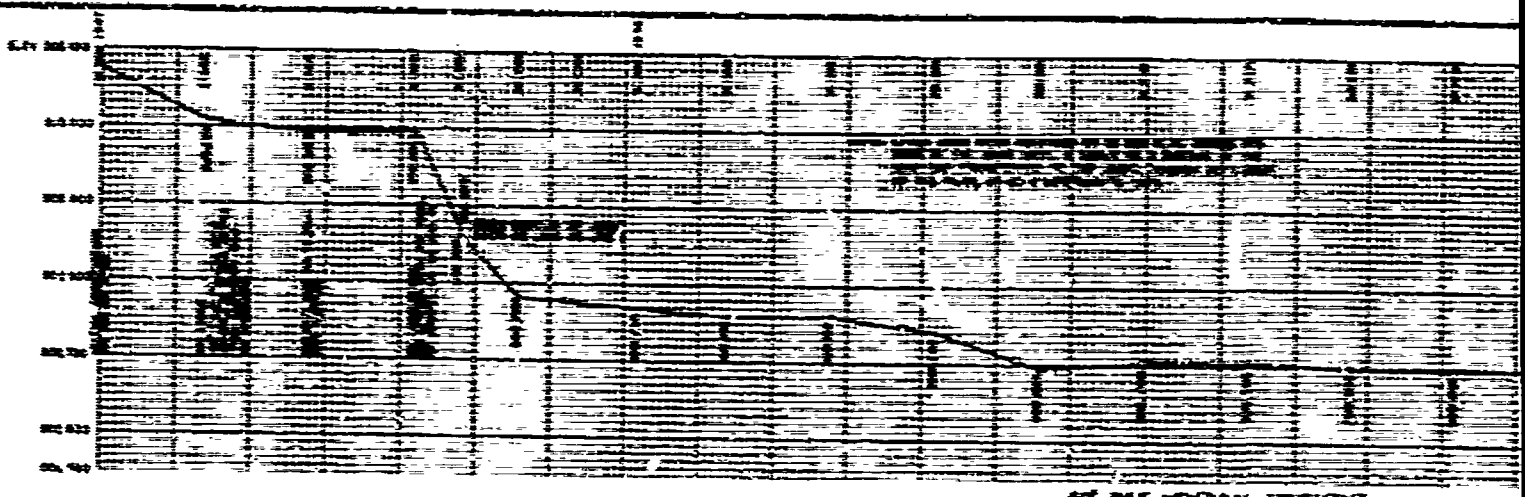

37' PILE-VERTICAL MOVEMENT

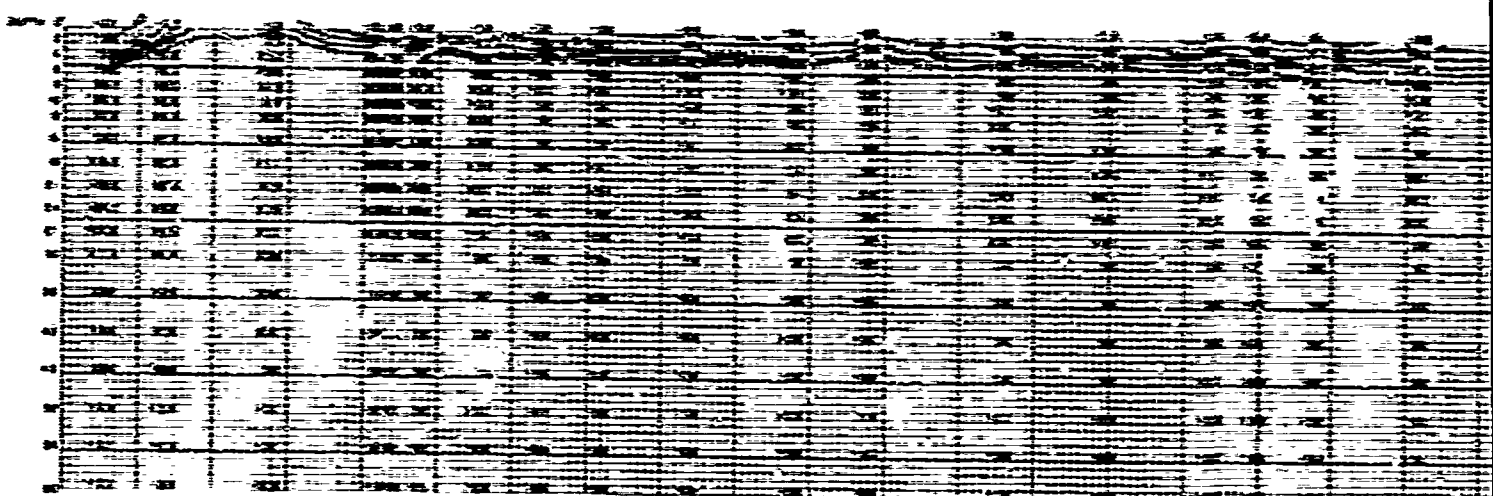

37' PILE-GROUND TEMPERATURES

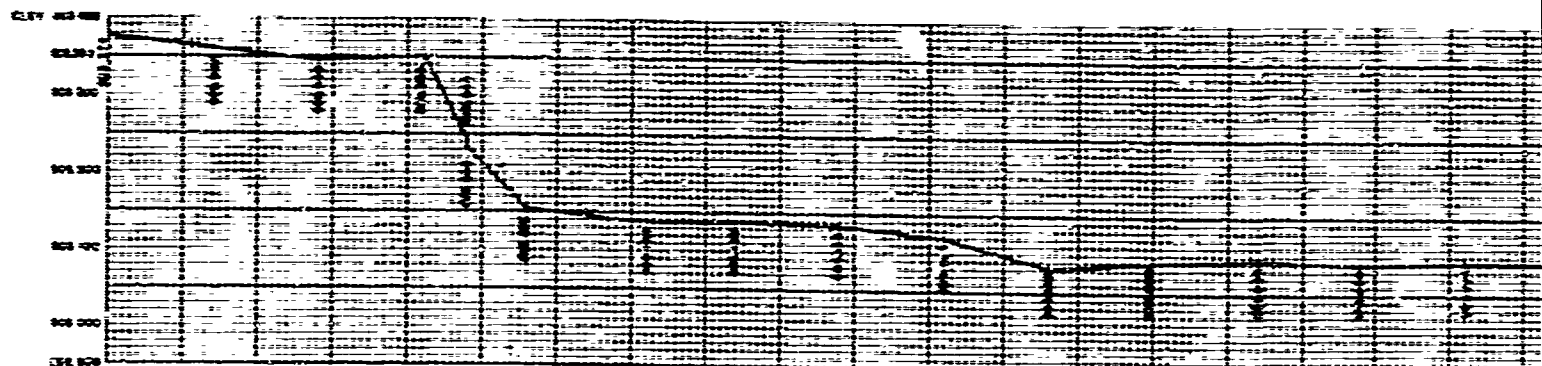

40' PILE-VERTICAL MOVEMENT

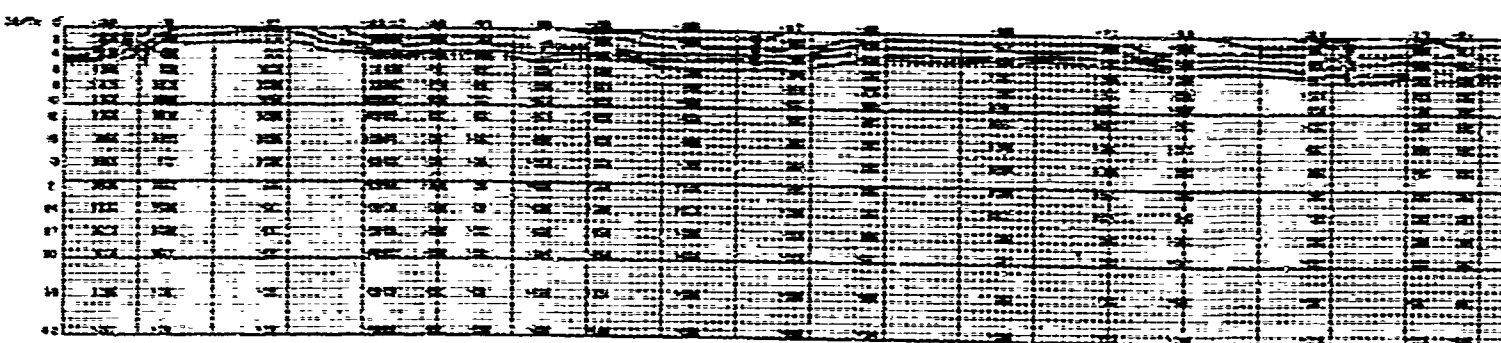

40' PILE-GROUND TEMPERATURES

A

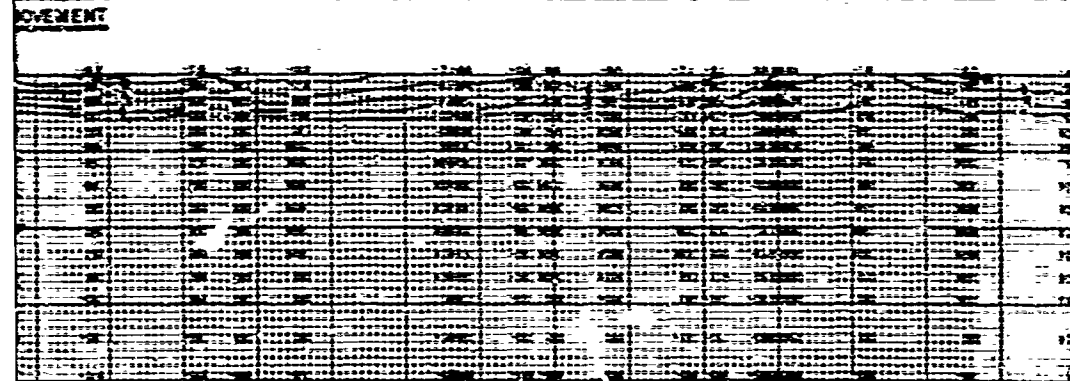
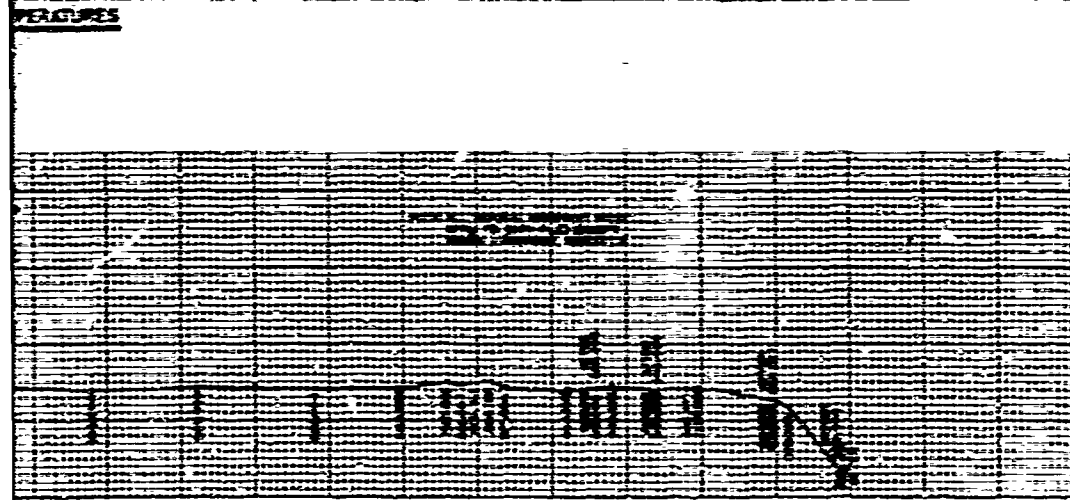
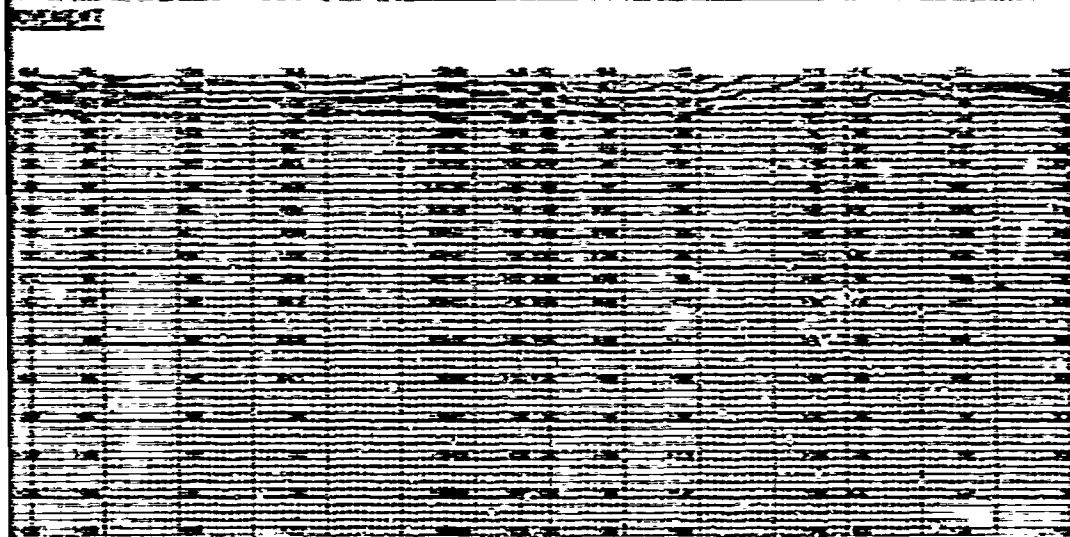
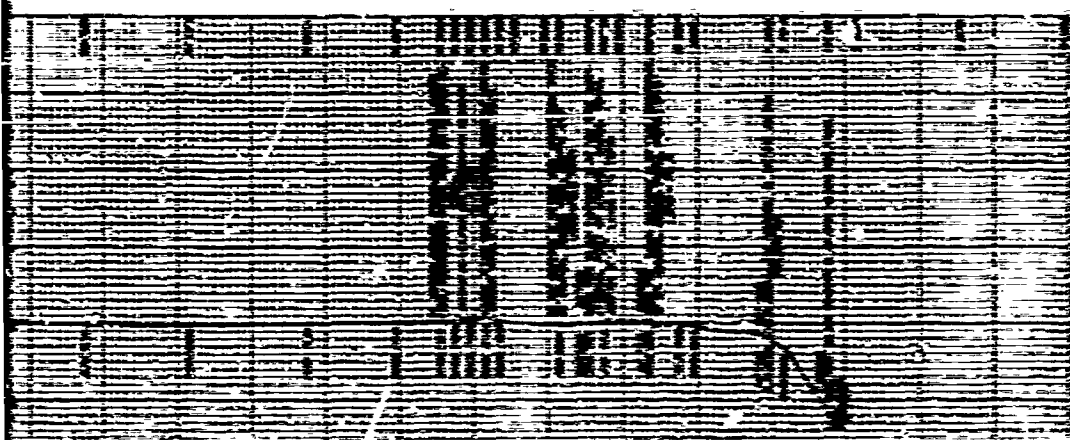

PERATURES

PERMAFROST INVESTIGATION
FIELD RESEARCH
FAIRBANKS, ALASKA
AREA NO. 3
MONOTUBE TEST PILES
VERTICAL MOVEMENT AND
GROUND TEMPERATURE CHART

SCALE AS SHOWN
 CORPS OF ENGINEERS ST. PAUL, MINN. MAY 1950
 DRAWN BY P.P.B. CHECKED BY S.P.C.

B