

BRL R 268

# BRL

AD 703499

REPORT NO. 268

## GEOMETRICAL AND DYNAMICAL RELATIONS GOVERNING THE BALLISTICS OF CLIMB AND GLIDE BOMBING

by

F. V. Reno

January 1942

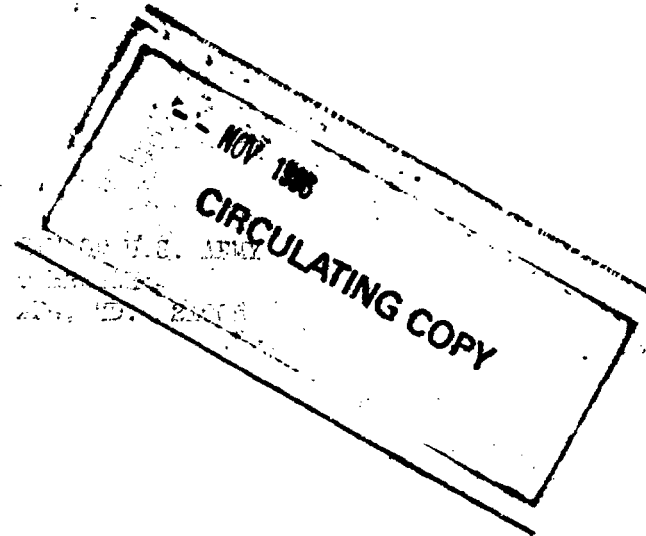

This document has been approved for public release and sale;  
its distribution is unlimited.

U.S. ARMY ABERDEEN RESEARCH AND DEVELOPMENT CENTER  
BALLISTIC RESEARCH LABORATORIES  
ABERDEEN PROVING GROUND, MARYLAND

Ballistic Research  
Laboratory Report 268

FVR/emh  
Aberdeen Proving Ground, Md.  
January 24, 1942

GEOMETRICAL AND DYNAMICAL RELATIONS GOVERNING  
THE BALLISTICS OF CLIMB AND GLIDE BOMBING

Abstract

Some phases of the ballistics of climb and glide bombing are presented in this report. This discussion is intended to provide a theoretical basis for consideration of proper instrumental equipment for this purpose. Standard bombing table conditions for climb and glide bombing are given. An explanation is made of the terminology and notation employed in the ballistics of this subject. General relations between the elements of the bomb trajectory with initial inclination to the horizontal are derived. A brief discussion of the conditions for hitting in climb and glide bombing is included.

OFFICE OF U.S. ARMY  
BALLISTIC RESEARCH  
LABORATORY, ABERDEEN PROVING GROUND, MD.

## I. Standard Bombing Table Conditions for Climb and Glide Bombing

The requirement that bombing be conducted from horizontal flight in order to satisfy the conditions for hitting severely restricts the character of the airplane flight. An enormous advantage in maneuvering would result if instrumental equipment were built to provide for satisfaction of the conditions for hitting when the airplane flight path departs from the horizontal by a moderate angle. Insofar as it is possible, this instrumentation should provide for automatic introduction of the effects of climb and glide on the elements set on the bomb sight. The new instrumentation should introduce neither any new inconvenience to the bombardier nor any new source of inaccuracy in bombardment, but should free the pilot from the requirement of maintaining horizontal flight during the approach to the release point. This report is intended to provide a theoretical basis for consideration of proper instrumental equipment for climb and glide bombing.

In order to provide correct instrumentation for climb and glide bombing, the standard conditions assumed for the bombing must be assigned in advance. Some bombing table conditions are not employed in the present discussion, but a complete statement of these conditions appears desirable in order to make possible a comparison with the standard bombing table conditions for horizontal flight bombing.

Bombing tables will be computed for climb and glide bombing. The theory forming the basis for the computation of the elements appearing in the bombing tables will be developed from the following standard bombing table conditions for climb and glide bombing:

1. The aerodynamic constants of the bomb are normal.
  - a. The mass of the completely assembled bomb is normal.
  - b. The dimensions and assembly of the bomb are normal.
2. The initial conditions are normal.
  - a. The air flight path of the airplane is a straight line traversed at a constant true air speed.
  - b. There is no pitching, rolling, or yawing of the airplane at the instant of release.
  - c. The bomb is released with its axis parallel to the thrust line of the airplane.

d. The bomb sight is located at the center of gravity of the bomb at the instant of release.

e. There is no time lag in the operation of the bomb racks.

3. The atmosphere has the normal structure.

a. The density of the air has the normal structure for ballistics.

b. There is no vertical wind and no differential horizontal wind at any depth.

4. The forces acting on the bomb are normal.

a. The local apparent gravitational field of the earth has a direction everywhere normal to the surface of still water and an intensity equal to that due to a homogeneous sphere for which the superficial intensity is 9.8 meters per second per second and the radius is equal to the earth's local radius vector.

b. There is no rotation of the earth.

5. The target is at sea level.

The target will be supposed motionless with respect to the earth throughout this report. This restriction, which is unnecessary for a general treatment of the problem, can be removed at any time the more general treatment may be desired.

## II. Terminology and Notation Employed in the Ballistics of Climb and Glide Bombing

Several different frames of references are convenient for the treatment of different phases of the ballistics of climb and glide bombing. Three frames of reference will be used in this report. The first with coordinates  $x, y, z$ , is stationary with respect to the earth, and will be denoted by E. The second with coordinates  $x', y', z'$ , is fixed with respect to a horizontally moving airstream at the altitude of release and will be denoted by A. The third, with coordinates  $x'', y'', z''$ , is fixed with respect to the bombing airplane and will be denoted by B. Reference frame E is a rectangular frame with its origin,  $O_E$ , at the point of release of the bomb. The x axis takes the direction of the vector ground speed of the airplane, the y axis has the direction of the plumb line at  $O_E$  and the z axis is horizontal, perpendicular to the x axis and positive to the right. The reference frame E will be referred to as the Ground Observer's Reference Frame.

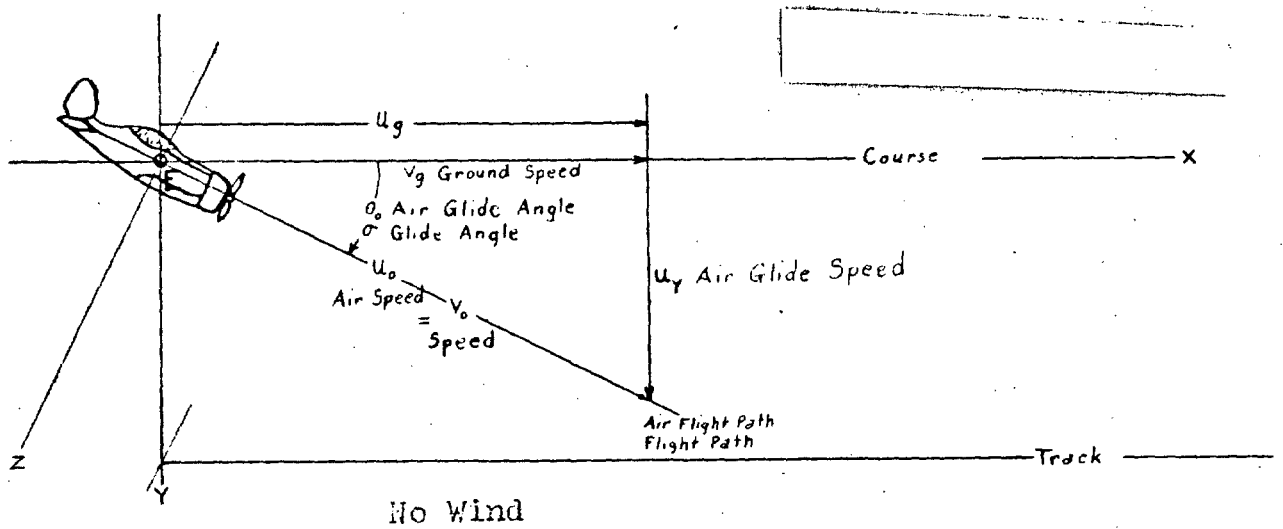

No Wind

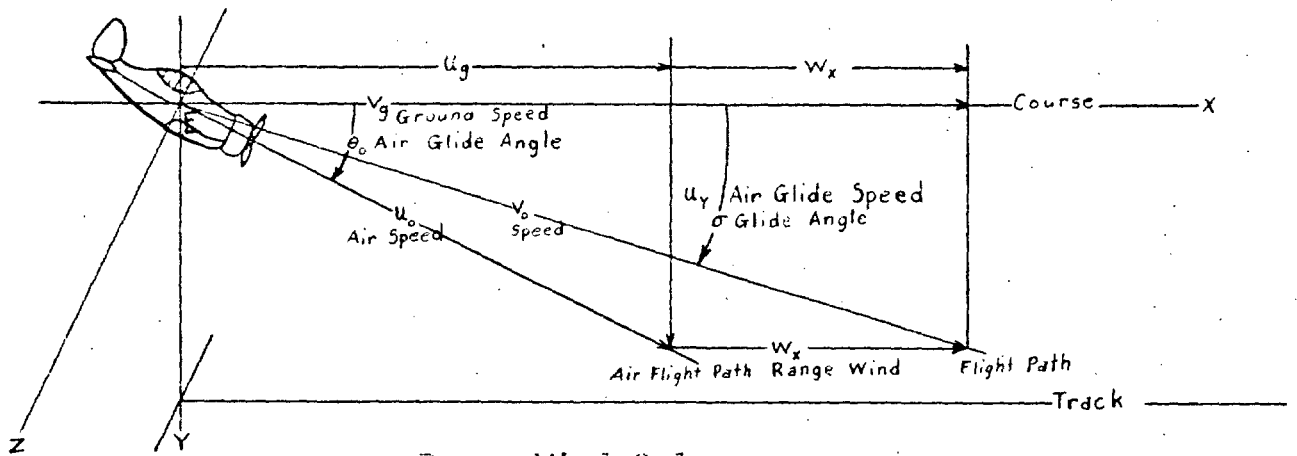

Range Wind Only

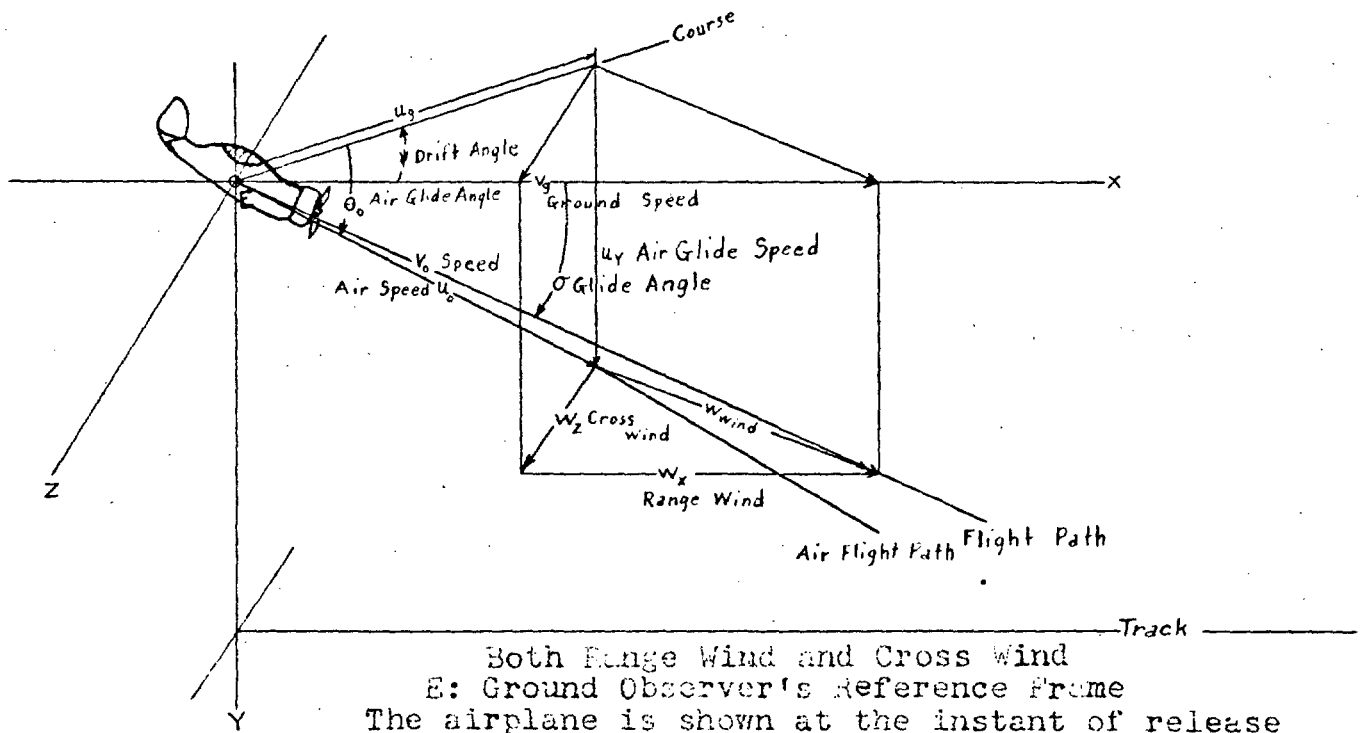

Both Range Wind and Cross Wind  
 E: Ground Observer's Reference Frame  
 The airplane is shown at the instant of release

Diagram, 1

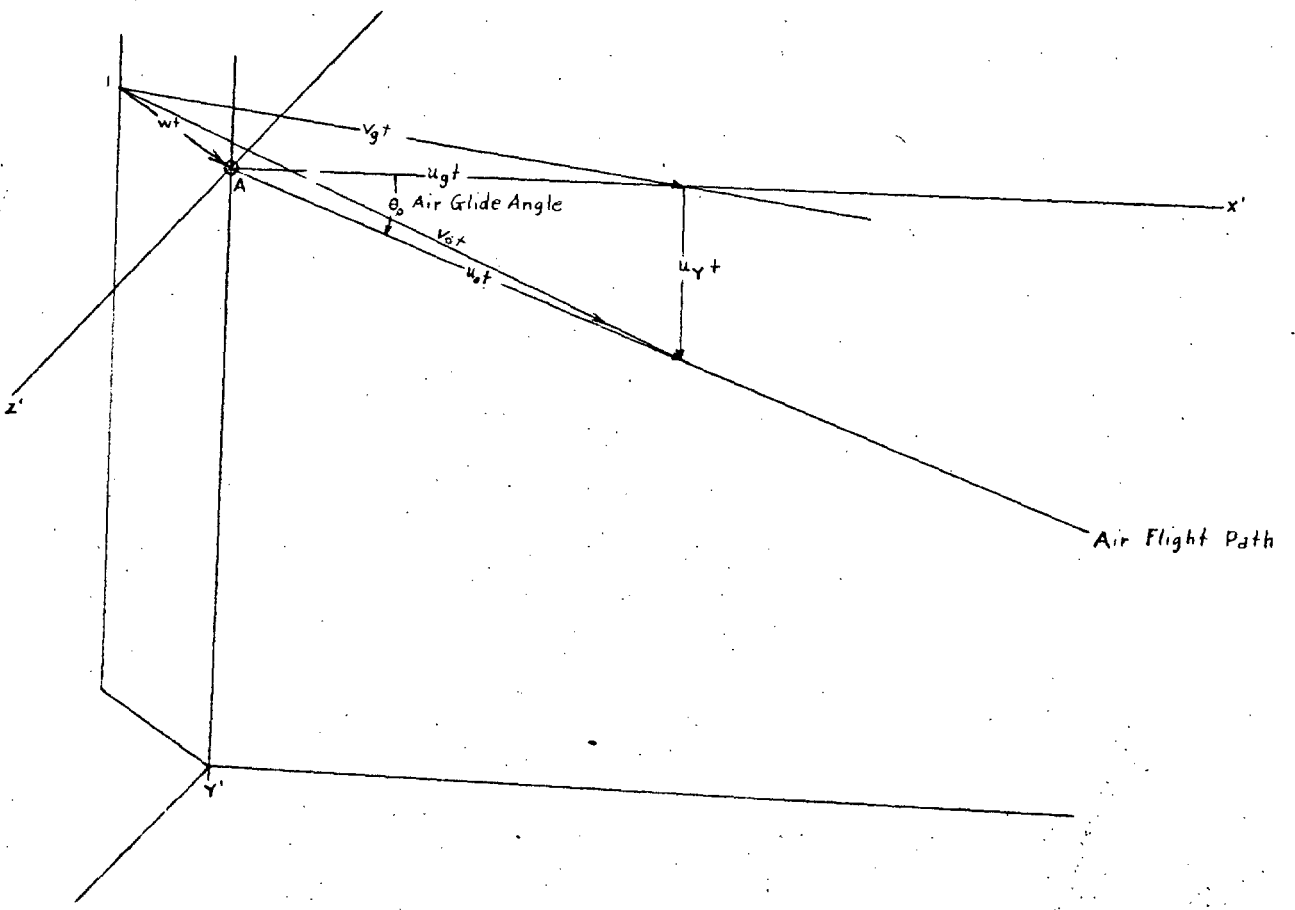

Air Reference Frame

Diagram 2

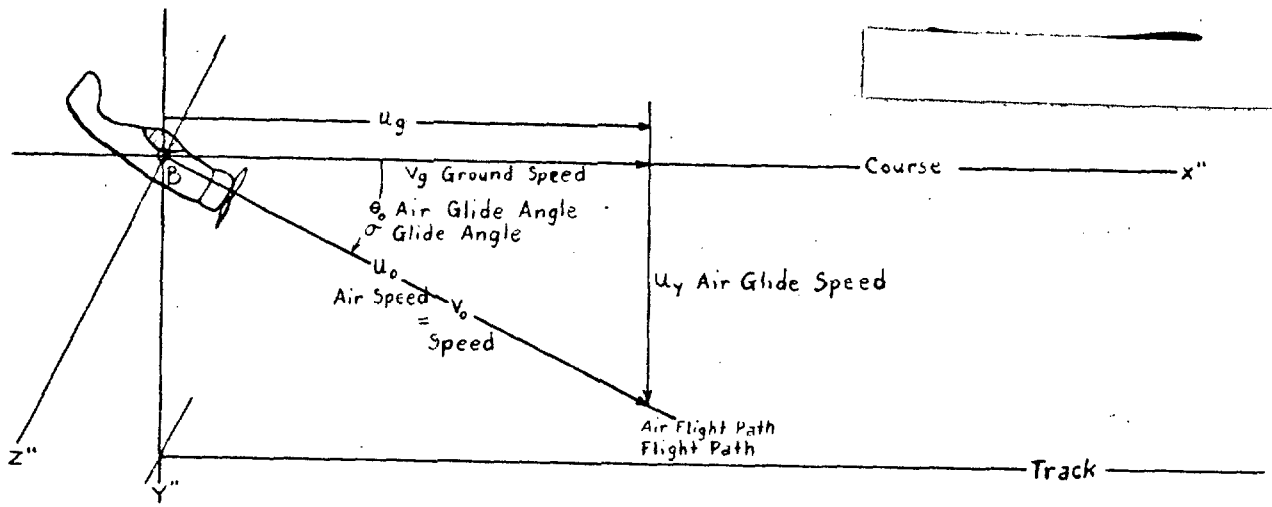

No Wind

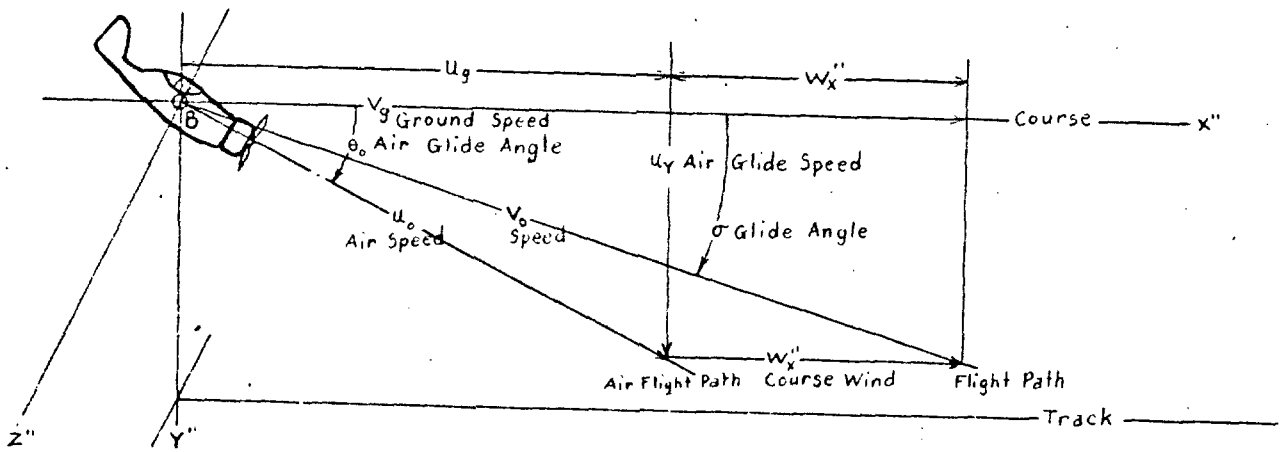

Course Wind Only

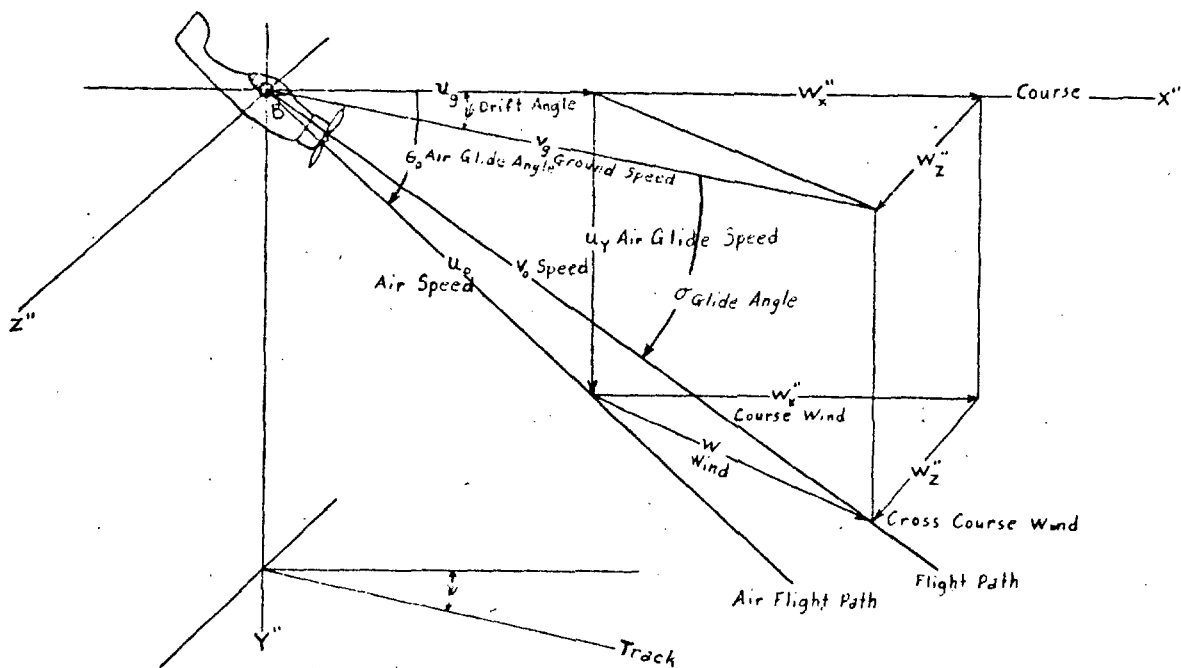

Both Course Wind and Cross Course Wind

Bombardier's Reference Frame

Diagram 3

Reference frame A is a rectangular frame with its origin,  $O_A$ , at the point of release of the bomb. The origin moves with the wind. Let the horizontal projection of the vector air speed be denoted by  $u_g$ . The  $x'$  axis is parallel to  $u_g$ , the  $y'$  axis has the direction of the plumb line at  $O_A$  and the  $z'$  axis is horizontal, perpendicular to the  $x'$  axis and positive to the right. The reference frame A will be referred to as the Air Reference Frame.

Reference frame B is a rectangular frame with its origin at a point in the vertical plane through the thrust line of the airplane. The  $x''$  axis has the direction of the course, the  $y''$  axis has the direction of the plumb line at  $O_B$ , and the  $z''$  axis is horizontal, perpendicular to the  $x''$  axis and positive to the right. The reference frame B will be referred to as the Bombardier's reference Frame.

It appears advisable to discuss briefly the following terms and notation.

The flight path is the path in space described by the center of mass of the airplane with respect to the earth.

The air flight path is the path in space described by the center of mass of the airplane with respect to the air.

The course is the line which passes through the center of mass of the airplane and is directed along the horizontal component of the air speed vector.

The track is the projection of the flight path on the ground.

The line of site is the line from the bombardier's eye to the target.

The aiming line is the line of site at the instant of release.

$\sigma$  The glide angle,  $\sigma$ , is the angle between the ground speed vector and the flight path, measured positive downward.

$\theta_0$  The air glide angle,  $\theta_0$ , is the angle between the course and the air speed vector.

$\psi$  The drift angle,  $\psi$ , is the angle between the ground speed vector and the horizontal component of the air speed vector.

- $\eta$  The angle of site,  $\eta$ , is the angle between the vertical through the bombardier's eye and the line of site.
- $v_o$  The speed,  $v_o$  is the velocity of the center of mass of the airplane with respect to the earth.
- $v_g$  The ground speed,  $v_g$ , is the horizontal component of the speed.
- $u_o$  The air speed,  $u_o$ , is velocity of the center of mass of the airplane with respect to the air.
- $u_g$  The horizontal component of the air speed is denoted by  $u_g$ .
- $v_y$  The glide speed,  $v_y$ , is the vertical component of the speed.
- $u_y$  The air glide speed,  $u_y$ , is the vertical component of the air speed.  $u_y = v_y$  By reason of standard bombing table condition  $\text{3b.}$ , it is easily shown that the air glide speed and the glide speed are the same. These quantities will be used interchangeably throughout this report.
- $T$  The time of flight,  $T$ , is the interval between the instant of release and the instant of impact of the bomb.
- $\nu$  The time of flight in vacuo is denoted by  $\nu$ .
- $v_y T$ , The drop,  $V_y T$ , is the change of altitude of the airplane during the time of flight of the bomb.
- $X$  The range,  $X$ , is the track component of the distance traversed by the bomb with respect to the ground during the time of flight.
- $\xi$  The range in vacuo is denoted by  $\xi$ .
- $X'$  The air range,  $X'$ , is the course component of the distance transversed by the bomb with respect to the air during the time of flight.
- $\xi'$  The air range in vacuo is denoted by  $\xi'$ .
- $v_g T$  The travel,  $V_g T$ , is the track component of the distance traversed by the airplane with respect to the ground.

$u_g^T$  The air travel,  $u_g^T$ , is the course component of the distance traversed by the airplane with respect to the air.

$\lambda$  The trail,  $\lambda$ , is the distance on the impact plane between the point of impact and the vertical through the bomb rack of the airplane at the instant of impact.

$\phi$  The azimuth of the trail,  $\phi$ , is the angle between the track and the trail, measured counterclockwise from the track toward the trail.

$\mu$  The trail ratio,  $\mu$ , is the trail divided by one thousandth of the altitude of release.

$$\mu = \frac{\lambda}{Y} 1000$$

~~$\gamma$~~   ~~$X$~~  The dropping angle,  $X$ , is the angle whose tangent is the range divided by the altitude of release.

$$\gamma \text{ ~~X~~ } = \tan^{-1} \left( \frac{X}{Y} \right).$$

$\delta$  The dropping angle in vacuo is denoted by  $\delta$ .

$Z$  The deflection,  $Z$ , is the perpendicular distance from the point of impact to the track, positive for an impact to the right of an observer looking along the ground speed vector.

$k$  The departure angle,  $k$ , is the angle whose tangent is the deflection divided by the altitude of release.

$$k = \tan^{-1} \left( \frac{Z}{Y} \right).$$

$B$  The range lag,  $B$ , is the difference between the air range in vacuo and the air range.

$$\begin{aligned} B &= u_g^U - X' \\ &= \xi' - X' \end{aligned}$$

$A$  The time lag,  $A$ , is the difference between the time of flight and the time of flight in vacuo.

$$A = T - \nu$$

$\beta$  The range lag ratio,  $\beta$ , is the range lag divided by one thousandth of the altitude of release.

$$\beta = \frac{B}{Y} 1000$$

$\alpha$  The time lag ratio,  $\alpha$ , is the time lag divided by one thousandth of the altitude of release.

$$\alpha = \frac{A}{Y} 1000$$

### III. Relations between the Elements of the Trajectory with Initial Inclination to the Horizontal

#### 1. Geometrical Relations between the Coordinates and Components of Velocity of a Point Measured With Respect to Various Frames of Reference

The origin of time will be taken at the instant of release. The origins of the three frames of reference coincide at this instant. The coordinate axes of the Air Reference Frame and the Bombardier's Reference Frame remain parallel to their original positions when viewed by a ground observer. The relative motion of the origins of any two of the three frames takes place along a straight line at constant velocity. A considerable number of results of importance for bomb ballistics can be deduced from the equations relating the coordinates of a point measured with respect to the Ground Observer's Reference Frame to the coordinates of the same point measured with respect to the Air Reference Frame or the Bombardier's Reference Frame.

At time  $t$ , the coordinates of the point relative to the Ground Observer's Reference Frame are  $x$ ,  $y$  and  $z$ ; the coordinates of the point relative to the Air Reference Frame are  $x'$ ,  $y'$  and  $z'$  and the coordinates of the point relative to the Bombardier's Reference Frame are  $x''$ ,  $y''$  and  $z''$ .

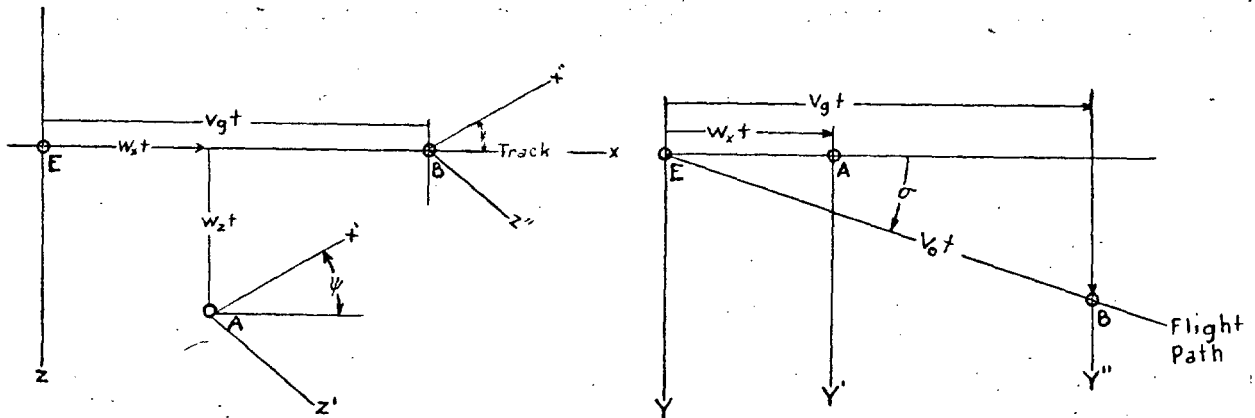

Plan

Elevation

Plan and Elevation of Reference Frames for Ballistics of Climb and Glide Bombing

Diagram 4

The transformations A to E and B to E are:

$$\left. \begin{aligned} x &= x' \cos \psi + z' \sin \psi + w_x t \\ y &= y' \\ z &= -x' \sin \psi + z' \cos \psi + w_z t \end{aligned} \right\} \quad (1)$$

$$\left. \begin{aligned} x &= x'' \cos \psi + z'' \sin \psi + v_g t \\ y &= y'' + u_y t \\ z &= -x'' \sin \psi + z'' \cos \psi \end{aligned} \right\} \quad (2)$$

The inverse transformations are:

$$\left. \begin{aligned} x' &= (x - w_x t) \cos \psi - (z - w_z t) \sin \psi \\ y' &= y \\ z' &= (x - w_x t) \sin \psi + (z - w_z t) \cos \psi \end{aligned} \right\} \quad (3)$$

$$\left. \begin{aligned} x'' &= x \cos \psi - z \sin \psi - v_g t \cos \psi \\ y'' &= y - u_y t \\ z'' &= x \sin \psi + z \cos \psi - v_g t \sin \psi \end{aligned} \right\} \quad (4)$$

It is also of some interest to compare the components of velocity of a moving point with respect to these reference frames. The results are:

$$\left. \begin{aligned} \dot{x} &= \dot{x}' \cos \psi + \dot{z}' \sin \psi + w_x \\ \dot{y} &= \dot{y}' \\ \dot{z} &= -\dot{x}' \sin \psi + \dot{z}' \cos \psi + w_z \end{aligned} \right\} \quad (5)$$

$$\left. \begin{aligned} \dot{x} &= \dot{x}'' \cos \psi + \dot{z}'' \sin \psi + v_g \\ \dot{y} &= \dot{y}'' + u_y \\ \dot{z} &= -\dot{x}'' \sin \psi + \dot{z}'' \cos \psi \end{aligned} \right\} \quad (6)$$

Thus a point, such as the target, which has no motion with respect to the Ground Observer's Reference Frame, has the following velocity components with respect to the Bombardier's Reference Frame:

$$\left. \begin{aligned} \dot{x}''_{\Omega} &= -v_g \cos \psi \\ \dot{y}''_{\Omega} &= -u_y \\ \dot{z}''_{\Omega} &= -v_g \sin \psi \end{aligned} \right\} \quad (7)$$

A point moving with the air, such as the origin  $O_A$ , which has no motion with respect to the Air Reference Frame, has the following velocity components with respect to the Ground Observer's Reference Frame:

$$\left. \begin{aligned} \dot{x}_A &= +w_x \\ \dot{y}_A &= 0 \\ \dot{z}_A &= +w_z \end{aligned} \right\} \quad (8)$$

The coordinates of the airplane with respect to the Ground Observer's reference Frame are of some interest. These are:

$$\left. \begin{aligned} x_p &= v_g t \\ y_p &= u_y t \\ z_p &= 0 \end{aligned} \right\} \quad (9)$$

It is of importance to note that:

$$\left. \begin{aligned} \cos \psi &= \frac{v_g - w_x}{u_g} \\ \sin \psi &= + \left( \frac{w_z}{u_g} \right) \end{aligned} \right\} \quad (10)$$

Important elements of the trajectory with respect to the Ground Observer's Reference Frame are  $X$ ,  $Z$  and  $T$ ; important elements of the trajectory for the Air Reference Frame are  $X'$ ,  $Z'$  and  $T$ . Since the clocks used by the observers record the same interval at any instant, the time of flight for the bomb,  $T$ , is of course, the same for all three reference frames. The travel has been defined as product of ground speed and time of flight. The trail,  $\lambda$ , has been defined as the distance on the impact plane between the point of impact and the vertical through the bomb rack of the airplane at the instant of impact under the assumption that the airplane moved with constant horizontal velocity during the time of flight of the bomb. The azimuth of the trail,  $\phi$ , has been defined as the angle between the track and the trail measured counterclockwise from the track to the trail.

It follows that:

$$\lambda = \sqrt{(v_g T - X)^2 + Z^2} = \sqrt{(u_g T - X')^2 + Z'^2} = \sqrt{X''^2 + Z''^2} \quad (11)$$

$$\phi = \arctan \frac{Z}{v_g T - X} = \psi + \arctan \frac{Z'}{u_g T - X'} = \psi + \frac{\pi}{2} + \arctan \frac{X''}{Z''}$$

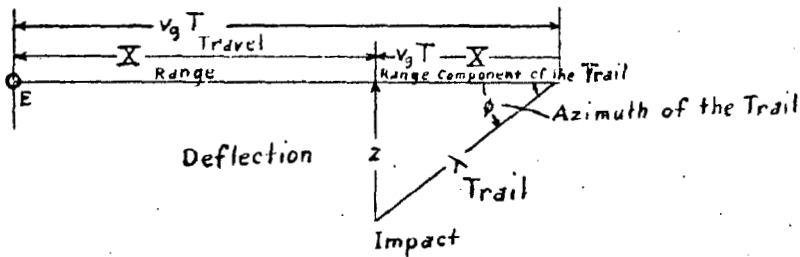

General Conditions

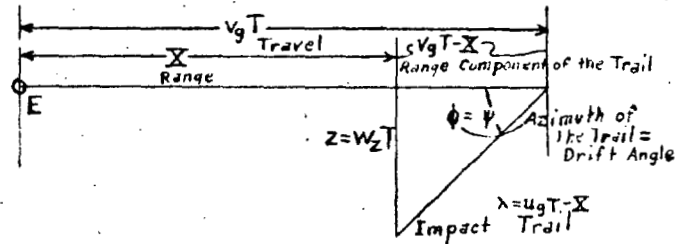

Standard Bombing Table Conditions

Plan Showing Elements of the Trajectory for Ground Observer's Reference Frame

Diagram 5

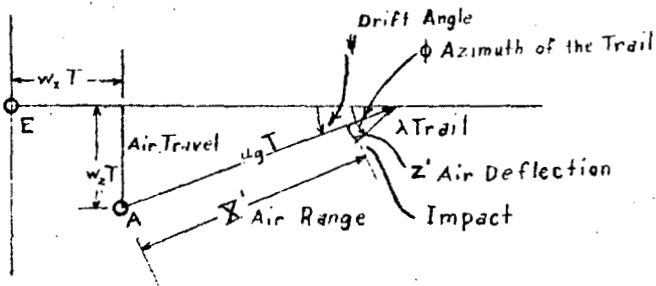

General Conditions

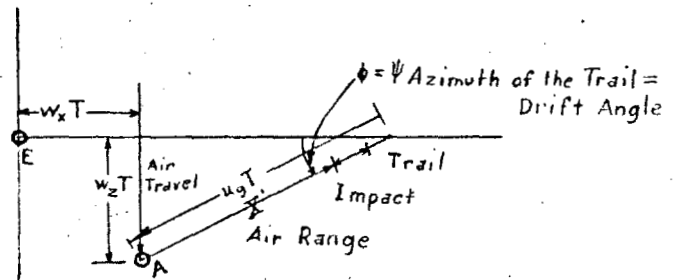

Standard Bombing Table Conditions

Plan Showing Elements of the Trajectory for Air Reference Frame

Diagram 6

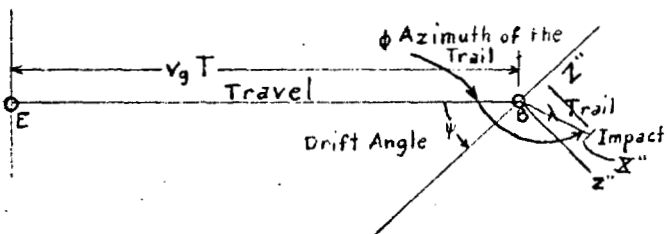

General Conditions

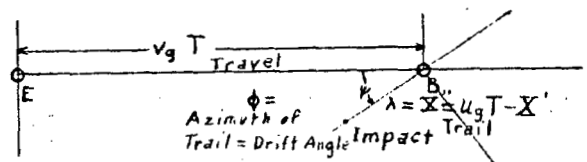

Standard Bombing Table Conditions

Plan Showing Elements of the Trajectory for Bombardier's Reference Frame

Diagram 7

Under standard bombing table conditions there is no force acting to displace the bomb from the vertical plane through the thrust line of the airplane if referred to air coordinates. If the elements under consideration are those pertaining to the bomb trajectory described under standard bombing table conditions, it follows that  $Z' = Z'' = 0$  and that  $\phi = \psi$ . Hence

$$\left. \begin{aligned} X &= X' \cos \psi + w_x T = X'' \cos \psi + v_g T \\ Z &= -X' \sin \psi + w_z T = -X'' \sin \psi \end{aligned} \right\} \quad (12)$$

$$\left. \begin{aligned} \lambda &= \sqrt{(v_g T - X)^2 + Z^2} = u_g T - X' = \sqrt{X''^2} \\ \phi &= \arctan \frac{Z}{v_g T - X} = \psi \end{aligned} \right\} \quad (13)$$

The first of equations (13) shows that the magnitude of the trail is absolutely independent of the magnitude or direction of the uniform wind of standard bombing table conditions. Then the trail and the time of flight under standard bombing table conditions depend upon the air-speed, glide speed, altitude and bomb, and require no correction for any wind which is constant in magnitude and direction with respect to depth.

Since the azimuth of the trail is equal to the drift angle, and the trail and time of flight depend upon the air speed and glide speed, but are independent of the ground speed, important advantages can be gained by use of these quantities in instrumentation for glide and climb bombing. This property of independence of the magnitude or direction of the constant wind is possessed by only a small number of elements of the trajectory. The property will be referred to again at a later point in this report; it will be described as the Invariance of the Trail, the property of invariance being understood to refer to the magnitude of the trail with respect to the wind. The property of invariance can also be deduced easily on physical grounds.

## 2. Properties of the Trajectory with Initial Inclination to the Horizontal in Vacuo

Some properties of the trajectory in vacuo will be found useful in the climb and glide bombing problem. The well known equations for range and depth of fall are:

$$\xi = v_g \nu \quad (14)$$

$$Y = \frac{g \nu^2}{2} + u_y \nu \quad (15)$$

The time of flight in vacuo is obtainable from (15). The result is

$$\nu = \sqrt{\frac{2Y}{g} + \left(\frac{u_y}{g}\right)^2} - \frac{u_y}{g} \quad (16)$$

By the elimination of  $\nu$  between (14) and (15), a relation between  $\xi$  and  $Y$  can be found. This relation is

$$Y = \frac{g \xi^2}{2v_g^2} + \frac{u_y \xi}{v_g} \quad (17)$$

The range in vacuo for horizontal flight will be denoted by  $\xi_0$  and the time of flight for the same condition by  $\nu_0$ .

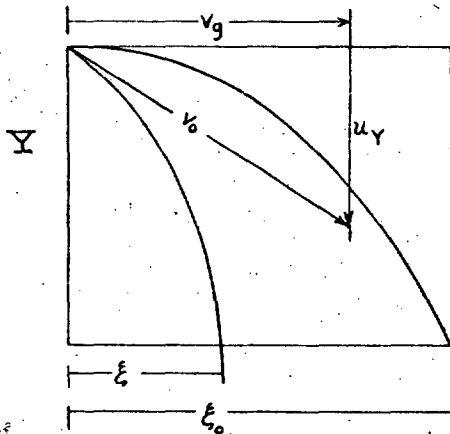

In the case of horizontal flight the relation (17) assumes the form:

$$Y = \frac{g \xi_0^2}{2v_g^2} \quad (18)$$

From (17) and (18) a relation may be found between the ranges in vacuo for horizontal and climb or glide flight for the same altitude of release and ground speed.

Ranges in Vacuo for Horizontal and Glide Flight for the same Altitude of Release and Ground Speed.

Diagram 8

This result is:

$$\frac{g \xi^2}{2v_g^2} + \frac{u_y \xi}{v_g} = \frac{g \xi_0^2}{2v_g^2} \quad (19)$$

Substitution of (14) into (19) and division of the left by the right hand side of the equation leads to:

$$\frac{v^2}{v_0^2} + \frac{\xi}{g u_0} \frac{u y}{v g} = 1 \quad (20)$$

From (15) it follows that:

$$Y = \frac{g v_0^2}{2} \quad (21)$$

Substitution of (21) into (20) followed by solution for  $(\frac{v}{v_0})$  yields:

$$\frac{v}{v_0} = \sqrt{1 - \left(\frac{u y}{v g}\right) \left(\frac{\xi}{Y}\right)} \quad (22)$$

By definition:

$$\tan \sigma = \frac{u y}{v g} \quad (23)$$

$$\tan \delta = \frac{\xi}{Y} \quad (24)$$

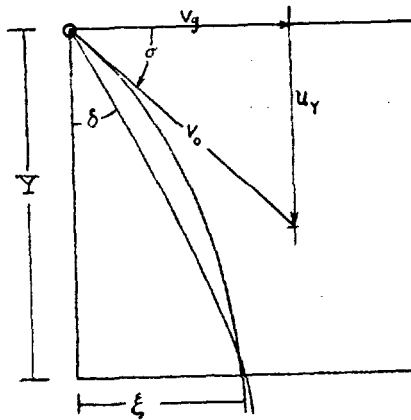

Then:

$$\frac{v}{v_0} = \sqrt{1 - \tan \sigma \tan \delta} \quad (25)$$

Glide Angle and Dropping  
Angle in Vacuo  
Diagram 9

It is evident from relations given before that:

$$\begin{aligned} \frac{\xi}{\xi_0} &= \frac{\tan \delta}{\tan \delta_0} = \frac{v}{v_0} = \sqrt{1 - \frac{u y v}{Y}} = \sqrt{1 - \tan \sigma \tan \delta} \\ &= \sqrt{1 - \left(\frac{u y}{v g}\right) \left(\frac{\xi}{Y}\right)} \end{aligned} \quad (26)$$

### 3. Relations between the Elements of the Climb or Glide Trajectory in Air

For the purpose of the bombardier, the correct dropping angle and departure angle must be set up by instrumental means. By definition:

$$\tan \chi = \frac{X}{Y} \quad (27)$$

$$\tan k = \frac{Z}{Y} \quad (28)$$

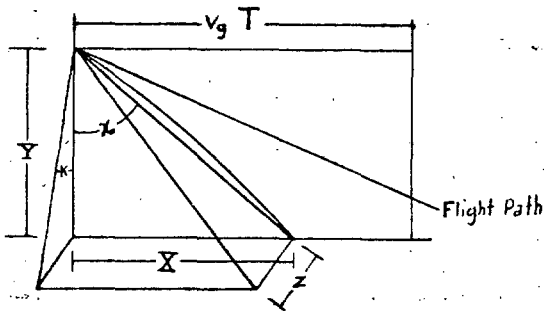

It is easier to set up the tangents of some angles by instrumental means than the angles themselves. Several other forms of relations (27) and (28) are convenient to employ in practice.

Dropping Angle and  
Departure Angle  
Diagram 10

Under standard bombing table conditions, the equations (27) and (28) are equivalent to:

$$\tan \chi = \frac{v_g T - \lambda \cos \psi}{Y} \quad (29)$$

$$\tan k = + \frac{\lambda \sin \psi}{Y} \quad (30)$$

Let H be defined by the relation

$$H = \frac{Y}{1000} \quad (31)$$

The trail ratio  $\mu$ , is defined by the relation

$$\mu = \frac{\lambda}{H} \quad (32)$$

By use of equations (31) and (32), the equations (29) and (30) can be reduced to

$$1000 \tan \chi = \frac{v_g T}{H} - \mu \cos \psi \quad (33)$$

$$1000 \tan k = + \mu \sin \psi \quad (34)$$

The quantity  $1000 \tan \chi$  will be denoted by  $p$  and described as the range ratio; the quantity  $\frac{T}{H}$  will be denoted by  $\pi$  and described as the time ratio and the quantity  $1000 \tan k$  will be denoted by  $\xi$  and described as the cross trail ratio. Evidently

$$\left. \begin{aligned} p &= v_g \pi - \mu \cos \psi \\ \xi &= + \mu \sin \psi \end{aligned} \right\} \quad (35)$$

The accepted unit of each term in equations (35) is the mil. The definition of the mil unit is a consequence of the definitions of the element ratios described above. Thus

$$k \text{ mils} = \tan^{-1} \frac{k}{1000} \quad (36)$$

The element ratios  $\pi$  and  $\mu$  are functions of the altitude of release,  $Y$ , the true air speed,  $u_o$ , the glide speed,  $u_y$ , and the ballistic coefficient of the bomb,  $C$ . Most other elements which could be used in the climb and glide ballistic problem depend on the magnitude and direction of the constant wind of standard bombing table conditions in addition to the foregoing quantities. Thus the use of most other elements would result in a requirement that wind corrections be used to compensate for the effects of the constant bombing table wind.

The employment of the range and time lag in bomb ballistics results in advantages for some purposes. Their use in instrumentation for bombing results, however, in one serious disadvantage: in order to satisfy the conditions for hitting, it is necessary to make corrections for the effects of the constant wind of standard bombing table conditions. The range lag denoted by  $B$ , is defined by the equation:

$$B = u_g \psi - X' \quad (37)$$

The time lag, denoted by  $A$ , is defined by the equation

$$A = T - \psi \quad (38)$$

Since inexplicit definitions are frequently employed for the range and time lags, it is desirable to employ definitions in the form of the equations (37) and (38). To guard against misinterpretation, it appears desirable to remark that the air range is denoted by  $X'$ , the time of flight in air by  $T$  and the time of flight in vacuo by  $\upsilon$ , all quantities being computed under standard bombing table conditions for climb and glide bombing. The quantities  $B$  and  $A$  therefore depend upon the altitude of release, true air speed, glide speed and the bomb employed.

The tangents of the dropping angle and the departure angle must be given in terms of the range lag and the time lag if these quantities are to be employed in bombing. The trail,  $\lambda$  has been given in the form:

$$\lambda = u_g T - X'$$

Elimination of  $X'$  and  $T$  from the trail equation by use of equations (37) and (38) leads to:

$$\lambda = u_g (\upsilon + A) - (u_g \upsilon - B) = u_g A + B \quad (39)$$

Substitution of (38) and (39) into (29) and (30) results in:

$$\tan \overset{\gamma}{X} = \frac{v_g (\upsilon + A) - (u_g A + B) \cos \psi}{Y} \quad (40)$$

$$\tan k = \frac{(u_g A + B) \sin \psi}{Y} \quad (41)$$

The equation (40) may be easily reduced to the form:

$$\tan X + \frac{\overset{\gamma}{v_g \upsilon} - B \cos \psi + (v_g - u_g \cos \psi) A}{Y} \quad (42)$$

Then if the range lag and the vacuum time are employed in bombing practice a wind correction should be added to the range component of the range lag. The wind correction would have the form

$$\Delta_{w_x} B = - \quad w_x A \quad (43)$$

By definition:

$$\beta = \frac{B}{H} \quad (44)$$

$$\alpha = \frac{A}{H} \quad (45)$$

$$\gamma = \frac{V}{H} \quad (46)$$

The quantity  $\beta$  is described as the range lag ratio, the quantity  $\alpha$  as the time lag ratio, and the quantity  $\gamma$  as the vacuum time ratio. The equations (40) and (41) are reducible to the form:

$$\left. \begin{aligned} p &= v_g \gamma - \beta \cos \psi + w_x \alpha \\ \zeta &= \mu \sin \psi \end{aligned} \right\} \quad (47)$$

The equations (47) are the analogues of equations (35). Since  $\gamma$  is independent of  $u_g$ , and of the bomb, there are certain advantages in the use of equations (47). These advantages appear to be compensated by the disadvantages resulting from the presence of four quantities,  $\gamma$ ,  $\beta$ ,  $\alpha$  and  $\mu$  which must be tabulated instead of the two,  $H$  and  $\mu$  which occur in equations (35). Other disadvantages will appear on closer examination.

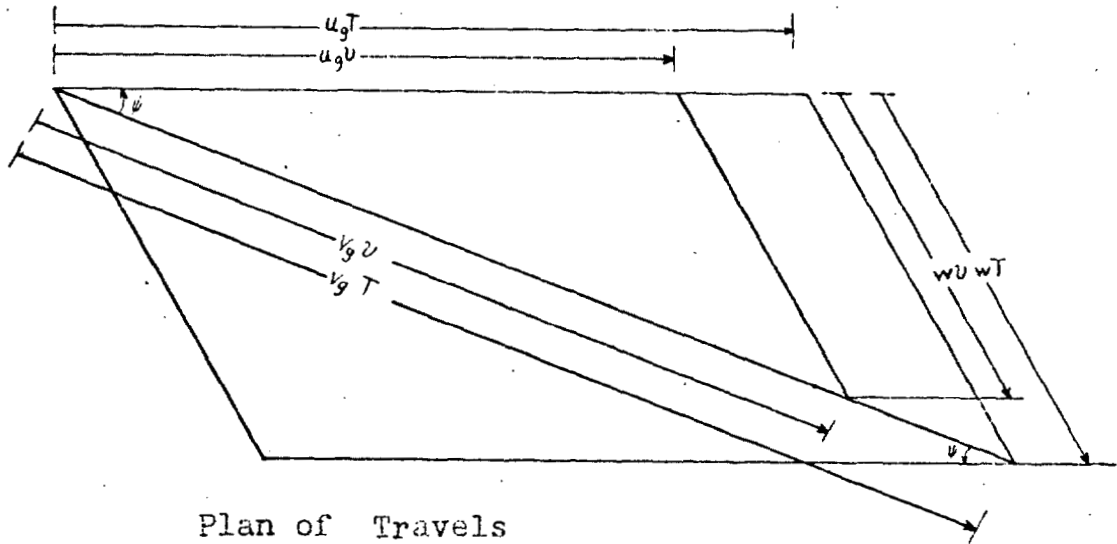

Plan of Travels

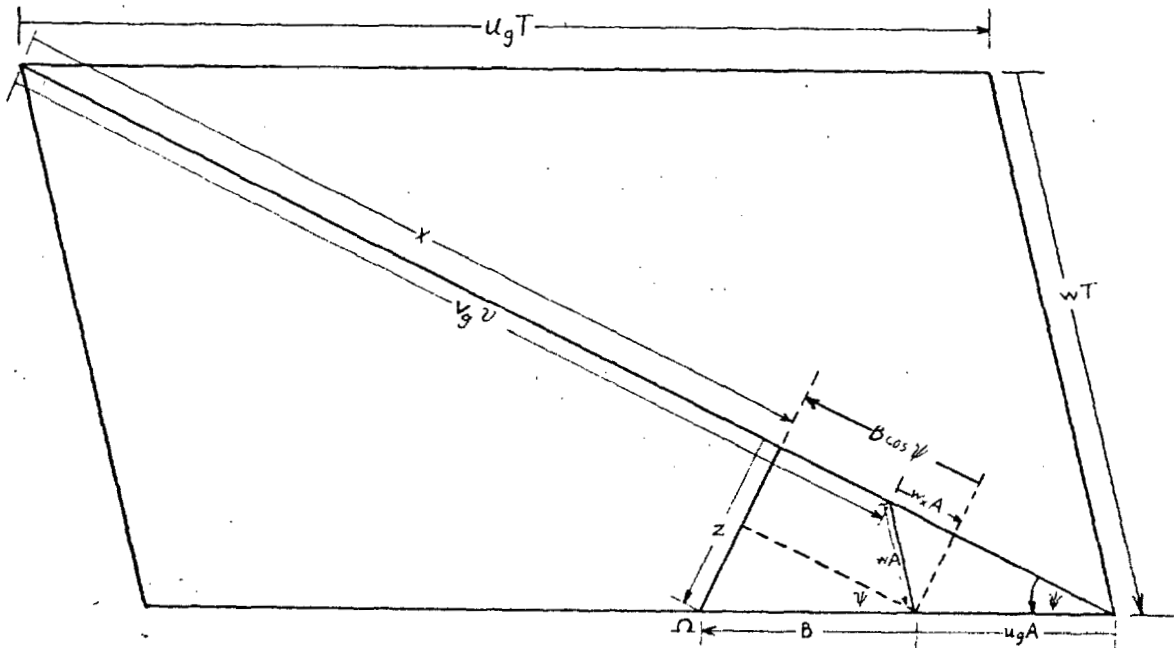

Plan of representation of Range and Deflection  
 in Relations  $\begin{cases} X = v_g v - B \cos \psi + w_x A \\ Z = (u_g A + B) \sin \psi \end{cases}$

Diagram 11

#### IV Conditions for Hitting in Climb and glide bombing

It is possible to satisfy the equations (35) by a proper aiming of the airplane and the use of a proper bombsight in such a way as to provide for a hit in an attack with drift. This may be done in an approach with any course whatever. The bombing technique depends, however, on the form of sight employed. The attack with any course is shown clearly in diagram 12.

Consider a target,  $\Omega$ , stationary with respect to the earth, a horizontal component of airspeed  $u_g$ , an air glide speed  $u_y$ , a uniform wind velocity vector  $w$ , an altitude of release,  $Y$  and an arbitrarily chosen course,  $CG$ . The conditions proposed result in the employment of the same value of trail ratio and time ratio in each case. The track lies along the line  $BA$  and the bomb is released at  $A$ . The extensions of the courses at the release circle all pass through the center of the release circle,  $G$ . The radius of the release circle is in every case the air range,  $X'$ . The track must be made to coincide with  $BK$  before arrival at the release circle.<sup>1</sup> If a sight of the proper form is employed, it is possible to use a sighting procedure which will avoid the necessity of locating the point  $P$ . It is advisable to use direct alignment on the target in the sighting procedure.

It appears difficult to describe the sighting procedure used to satisfy the conditions for hitting in climb and glide bombing in an attack with drift in advance of a description of the sight to be used. For this reason, an illustration will be drawn for the simpler case of attack without drift. In this case

$$\left. \begin{aligned} w_z &= 0 \\ \psi &= 0 \end{aligned} \right\} \quad (48)$$

the equations (35) reduce to:

$$\left. \begin{aligned} p &= v_g'' - \mu \\ \xi &= 0 \end{aligned} \right\} \quad (49)$$

<sup>1</sup> The procedure discussed here is similar to that described by E. J. Loring: "Bombs, Their Flight, Action, Test and Design", pages 19 and 20.

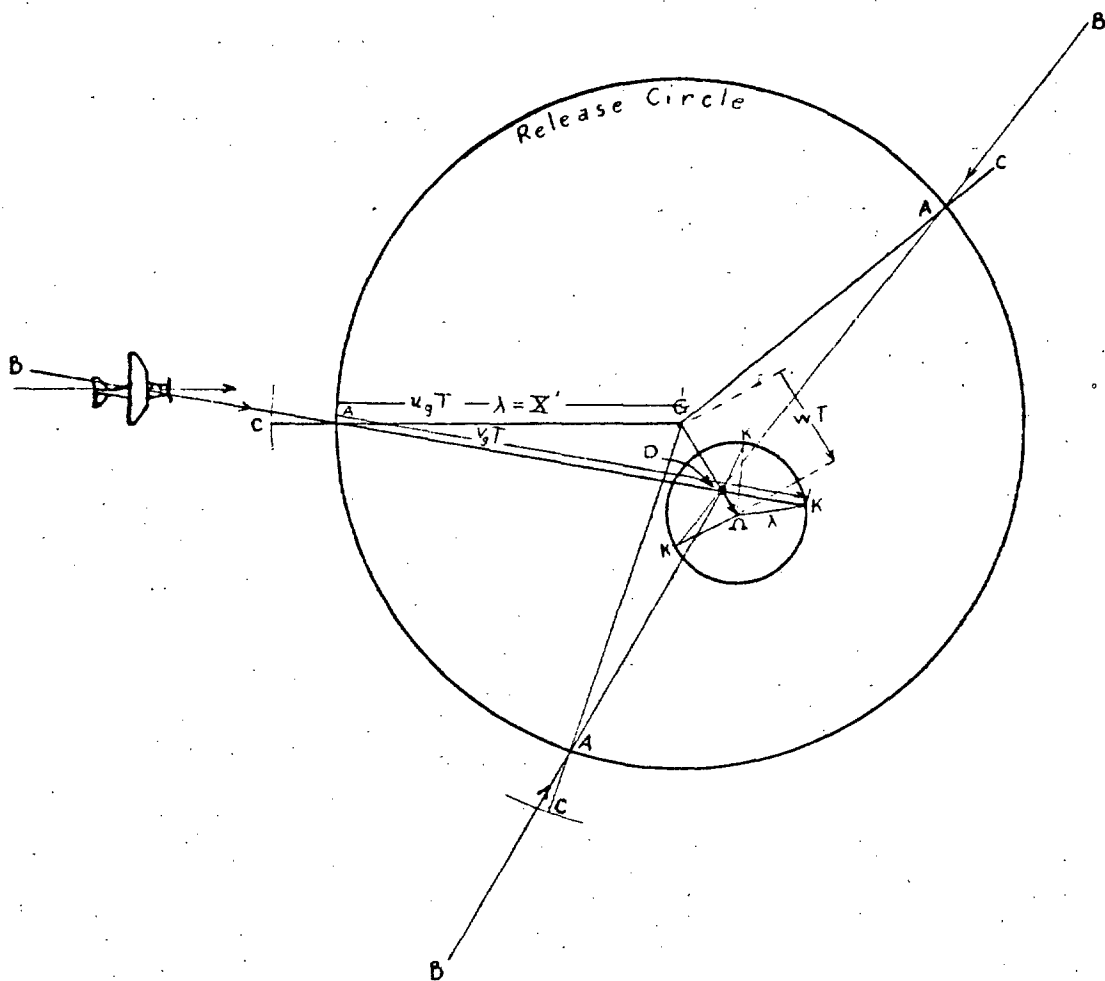

Plan of Bombing Attack with Drift  
 After E. J. Loring: "Bombs, Their Flight, Action,  
 Test and Design," page 20.

Diagram 12

The equations (49) would be used in case the quantities employed on the sight are trail ratio and time ratio.

In case the range lag ratio is employed, the equations (47) are used. For an attack without drift, these reduce to the form:

$$\left. \begin{aligned} p &= v_g \gamma - \beta + w_x \alpha \\ \xi &= 0 \end{aligned} \right\} \quad (50)$$

The wind correction to the range lag ratio is still necessary even though the attack is up or down wind.

The following illustration provides some insight into the geometrical relations involved in an attack in climb or glide bombing without drift. The line of sight has been defined as the line between the bombardier's eye and the target. Suppose that a plotting glass in the airplane is maintained in a horizontal position during the motion. The bombardier will be supposed to hold his eye at a constant distance  $h$  above the plotting board and to track the target. The velocity components of the target with respect to the Bombardier's Reference Frame are given by equations (7)

$$\left. \begin{aligned} \dot{x}''_{\Omega} &= -v_g \cos \psi \\ \dot{y}''_{\Omega} &= -u_y \\ \dot{z}''_{\Omega} &= v_g \sin \psi \end{aligned} \right\} \quad (7)$$

It has been supposed, although this restriction is by no means necessary, that there is no drift. Consequently:

$$\begin{aligned} \dot{x}''_{\Omega} &= -v_g \\ \dot{y}''_{\Omega} &= -u_y \\ \dot{z}''_{\Omega} &= 0 \end{aligned}$$

<sup>1</sup> This could be done by adjusting the plotting board until centering is achieved with a universal bubble level if the flight path of the airplane were perfectly straight and the velocity along that path perfectly constant.



that:

$$s = h \frac{S}{Y} \quad (52)$$

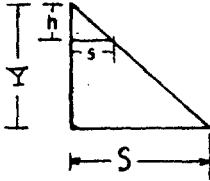

The speed of the line end is given by:

$$v_B = \frac{ds}{dt} = h \frac{Y \frac{dS}{dt} - S \frac{dY}{dt}}{Y^2} \quad (53)$$

Similar Triangles  
Employed in the  
Derivation of the  
Line End Speed  
Diagram 14

Substitution of relations used earlier into (53) results in:

$$v_B = \frac{hv}{Y} (1 - \tan \eta \tan \sigma) \quad (51)$$

Then if the bombardier arranges to make the telescope follow the target by some mechanism using a line in the position shown, the speed of the line end is given by the relation (51). This speed will be described as the bar speed.

In case the range lag ratio and the time of flight in vacuo are employed as basic elements from which bomb sight settings are deduced, the relation (51) is of considerable value. It may also be of some value in case trail ratio and time of flight in air are used, although this appears less probable. For this reason, the following development will concern only range lag ratio and time of flight in vacuo. Equation (42) is:

$$\tan \chi = \frac{v_g \psi - B \cos \psi + (v_g - u_g \cos \psi)A}{Y} \quad (42)$$

Since attack without drift is under consideration, the equation (42) can be reduced to

$$\tan \chi = \frac{v_g \psi - B + w_x A}{Y} \quad (54)$$

The time of flight in vacuo for glide speed  $u_y$  is related to the time of flight for horizontal bombing by equation (25). Multiplication of both sides of equation (25) by  $v_o$  leads to:

$$v = v_o \sqrt{1 - \tan \sigma \tan \delta} \quad (55)$$

Substitution of (55) into (54) leads to the relation:

$$\tan \chi = \frac{v_g v_o \sqrt{1 - \tan \sigma \tan \delta} - B + \frac{w_x A}{x}}{Y} \quad (56)$$

A construction which can be used by the bombardier will be sought. The line which turns the telescope so that the target can be tracked moves with a bar speed  $v_B$ . Consequently  $v_B$  will be used to eliminate  $v_g$  from equation (56). The bar speed,  $v_B$ , will presumably be adjusted by some type of rating mechanism. Then

$$\tan \chi = \frac{v_B v_o \sqrt{1 - \tan \sigma \tan \delta}}{h(1 - \tan \sigma \tan \eta)} - \frac{B}{Y} + \frac{w_x A}{Y} \quad (57)$$

The terms appearing in equation (57) are pure numbers. Distances on the positioning line will be found by multiplying the equation by  $h$ . The result is:

$$h \tan \chi = \frac{v_B v_o \sqrt{1 - \tan \sigma \tan \delta}}{1 - \tan \sigma \tan \eta} - \frac{hB}{Y} + \frac{hw_x A}{Y} \quad (58)$$

The value of  $\chi$  is fixed by the condition for hitting. This condition requires that the angle of site at the instant of release must be equal to the dropping angle. Then

$$\eta = \chi \quad (59)$$

This relation is tantamount to a certain assumption on the form of sight to be constructed, but it is consistent with the two dimensional problem now under consideration. Substitution of (59) into (58) results in:

$$h \tan \chi = \frac{v_B v_o \sqrt{1 - \tan \sigma \tan \delta}}{1 - \tan \sigma \tan \chi} - h \frac{B}{Y} + \frac{hw_x A}{Y} \quad (60)$$

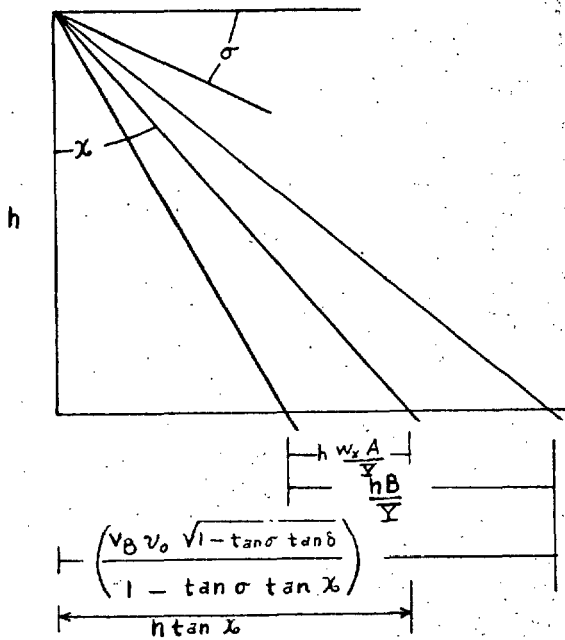

The terms given in equation (60) are proportional to travel distances on the track of the aircraft.

Representation of Distances on the Track  
of the Airplane by the Bombardier  
Diagram 15

The quantities to be employed in the instrumentation will probably include some of the five quantities  $v$ ,  $\beta$ ,  $q$ ,  $T$  and  $\mu$  which have been defined earlier in this report. It is important to note that each of the quantities  $\beta$ ,  $q$ ,  $T$  and  $\mu$  depend on the glide speed,  $u_y$ , as well as on the true air speed,  $u_o$ , the altitude,  $Y$ , and the ballistic coefficient of the bombs,  $C$ . The quantity  $v$ , however, depends only upon  $Y$  and  $u_y$ .

The general bulk of bombing tables to be employed can be greatly reduced by use of the fact that the dependence of these elements on some of their arguments is weak. In addition, the equations for hitting may be so rearranged as to make some of the quantities tabulated independent of one or more arguments. This will be illustrated by rearranging equation (33), modified for the condition of attack without drift.

$$1000 \tan \chi = \frac{v T}{H} - \mu \quad (61)$$

The effect of glide speed on the time of flight may be defined by

$$\Delta_{u_y} T = T - T_0 \quad (62)$$

where the time of flight for general climb or glide speed is denoted by  $T$  and the time of flight for horizontal bombing is denoted by  $T_0$ . Elimination of  $T$ , which depends upon  $u_y$ , from equation (61) leads to

$$1000 \tan \chi = \frac{v_g T_0}{H} - \mu + \frac{v_g \Delta_{u_y} T}{H} \quad (63)$$

The quantity  $(\mu - \frac{v_g \Delta_{u_y} T}{H})$  depends upon the five arguments  $v_g$ ,  $u_y$ ,  $u_0$ ,  $Y$  and  $C$ , but  $\frac{T_0}{H}$  depends only on three arguments  $u_0$ ,  $Y$  and  $C$ .

Some difficulties in provision for exact determination of the quantity  $\frac{v_g \Delta_{u_y} T}{H}$  would be present. The difficulties are due largely to the

fact that the ground speed vector is the sum of the wind vector and the horizontal component of the airspeed vector. The difficulties do not appear insuperable. The quantities employed can be arranged so as to provide for use of primary bombing tables with arguments  $u_0$  and  $Y$  for horizontal flight, together with secondary tables of corrections to some of these quantities to compensate for the effects of climb or glide speed. The primary functions will require extensive tables but the secondary functions may be tabulated at wide intervals in their arguments and so put in a small space. A proper choice of secondary function will enable the ballisticians to make use of approximate constancy or linearity of the chosen function with respect to some of its arguments. General bomb ballistic tables for climb and glide bombing are now in the course of preparation in the Ballistic Research Laboratory. After the proper instrumentation has been developed and the necessary experimental data obtained, bombing tables for climb and glide bombing can be computed from these general bomb ballistic tables.

The writer is indebted to Major D. M. Kilpatrick, Air Corps, Materiel Division, Wright Field, for ideas and helpful proposals which have made it possible to write this report. Capt. P. N. Gillon, Asst. Director and Dr. L. S. Dederick, Associate Director of the Ballistic Research Laboratory have examined the report critically and their valuable suggestions have

been used. Mrs. M. J. Shock has prepared the list of precise definitions which appears in the body of the report and Mrs. L. B. Howell has made most of the diagrams which appear in the text. The report includes suggestions made by Mr. E. S. Martin, Mr. Simon Mowshowitz and Mr. Arthur Stein.

F. V. Reno