

AD703719

AFFTC



**DEVELOPMENT OF A  
DATA ANALYSIS TECHNIQUE  
FOR DETERMINING THE  
LEVEL FLIGHT PERFORMANCE  
OF A HELICOPTER**

**JOHN R. SOMSEL**  
Aerospace Engineer

**TECHNOLOGY DOCUMENT No. 70-1**

**MARCH 1970**

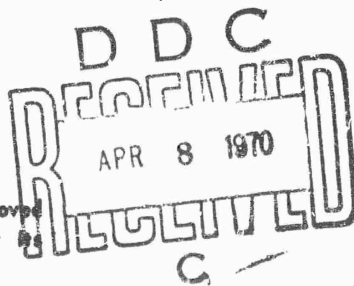

This document has been approved  
for public release and resale; its  
distribution is unlimited.

Reproduced by the  
CLEARINGHOUSE  
for Federal Scientific & Technical  
Information Springfield Va 22151

**AIR FORCE FLIGHT TEST CENTER  
EDWARDS AIR FORCE BASE, CALIFORNIA  
AIR FORCE SYSTEMS COMMAND  
UNITED STATES AIR FORCE**

# DISCLAIMER NOTICE

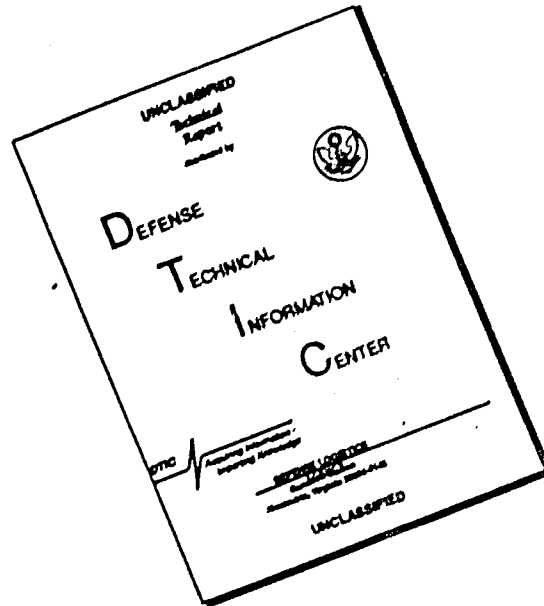

THIS DOCUMENT IS BEST QUALITY AVAILABLE. THE COPY FURNISHED TO DTIC CONTAINED A SIGNIFICANT NUMBER OF PAGES WHICH DO NOT REPRODUCE LEGIBLY.

**FTC-TD-70-1**

**DEVELOPMENT OF A  
DATA ANALYSIS TECHNIQUE  
FOR DETERMINING THE  
LEVEL FLIGHT PERFORMANCE  
OF A HELICOPTER**

**JOHN R. SOMSEL**  
Aerospace Engineer

This document has been approved  
for public release and resale; its  
distribution is unlimited.

## FOREWORD

This document was previously submitted to the faculty of the Aerospace and Mechanical Engineering Department in partial fulfillment of the requirements for the degree of Master of Science at the University of Arizona. This graduate study was financed by the Air Force Flight Test Center, Edwards Air Force Base, California. Special thanks are extended to Professor Edwin K. Parks of the Aerospace and Mechanical Engineering Department for his help and guidance in the preparation of this report.

The author also wishes to acknowledge the aid of Mr. Laurance A. Neitz for his assistance in the computer programming of this analysis.

Publication of this technology document does not constitute Air Force approval of the study's findings or conclusions. It is published only for the exchange and stimulation of ideas in the area of data analysis techniques for helicopter level flight performance.

**Prepared by:**

  
**JOHN R. SOMSEL**  
Aerospace Engineer

**Reviewed and approved by:**  
18 MARCH 1970

  
**THOMAS J. CECIL**  
Colonel, USAF  
Commander, 6512th Test Group

  
**ALTON O. SLAY**  
Brigadier General, USAF  
Commander

## ABSTRACT

This paper reviews and expands a helicopter level flight performance data analysis procedure that was formulated by Dr. E. K. Parks of the Aerospace and Mechanical Engineering Department, University of Arizona. The data analysis procedure presents formulae to account for rotor blade compressibility and stall effects which until recently have been largely ignored in classical rotor analyses. The initial approach for determining a helicopter's level flight power required was through a power buildup concept. This concept was modified during the report to be more compatible with the flight test environment. Flight test data of the CH-3C helicopter was used for comparing and verifying the analytic determinations. Reasonable approximations to the CH-3C flight test data was attained, although an improvement in accuracy is needed before the method can be substantiated as a valid flight test procedure. The analytic approach utilized was considered to possess the potential for arriving at a solution and further studies in this area are strongly recommended.

## TABLE OF CONTENTS

	<u>Page No.</u>
LIST OF ILLUSTRATIONS _____	v
LIST OF ABBREVIATIONS AND SYMBOLS _____	vi
INTRODUCTION _____	1
EVALUATION _____	5
GENERAL _____	5
ADVANCING BLADE COMPRESSIBILITY CORRECTION _____	8
RETREATING BLADE STALL CORRECTION _____	13
RESULTS _____	16
CONCLUSIONS AND RECOMMENDATIONS _____	18
APPENDIX I _____	19
TERMINOLOGY _____	19
DERIVATION OF MAJOR EQUATIONS _____	20
DATA PLOTS _____	23
BIBLIOGRAPHY _____	45

LIST OF ILLUSTRATIONS

<u>Figure</u>	<u>Title</u>	<u>Page No.</u>
1	General Rotor Nomenclature _____	19
2	Variation of $dC_d/\alpha$ with Mach Number _____	23
2a	Profile-drag coefficient versus Mach Number _____	24
3	Variation of $M_{cr}$ with Angle of Attack _____	25
4	Variation of $C_{l_{max}}$ with Mach Number _____	26
5	Incompressible Level Flight Performance _____	27
6-12	Nondimensional Level Flight Performance _____	28-34
13-22	Level Flight Performance _____	35-44

LIST OF ABBREVIATIONS AND SYMBOLS

<u>Item</u>	<u>Definition</u>	<u>Units</u>
A, B.....F	variable constants	---
AFFTC	Air Force Flight Test Center	---
b	number of rotor blades	---
c	rotor blade chord length	ft
$C_{l}, C_{l}$	rotor blade section lift coefficient	---
$\bar{C}_{l}$	rotor blade mean lift coefficient	---
$C_{p}$	power coefficient	---
$C_{pc}$	compressible power coefficient	---
$C_{pi}$	induced power coefficient	---
$C_{pic}$	incompressible power coefficient	---
$C_{poi}$	incompressible profile power coefficient	---
$C_{ps}$	stall power coefficient	---
$C_{T}$	thrust coefficient	---
$dC_{l}/d\alpha$	slope of the lift curve	l/deg
dr	increment of blade radius	ft
f	parasite area of fuselage	ft <sup>2</sup>
K	constant of proportionality	---
$K_{1}, K_{2}.....K_{n}$	variable constants	---

<u>Item</u>	<u>Definition</u>	<u>Units</u>
$M_r$	Mach number at blade radius $r$	---
$M_{cr}$	critical Mach number	---
$M_{TIP}$	advancing blade tip Mach number $= M_{(1, 90)}^1$	----
$P$	power required	ft-lb/sec
$r$	rotor blade radial position from the hub	ft
$R$	rotor radius	ft
$r_{cr}$	the blade radius outboard of which $M_r$ is greater than $M_{cr}$	ft
$r_s$	rotor radius outboard of which $C_l$ is greater than $C_{l_{max}}$	ft
SHP	shaft horsepower	550 ft-lb/sec
$T$	temperature	deg K
$V_t$	true airspeed	ft/sec
$W$	aircraft gross weight	lb
$\alpha$	rotor blade section angle of attack	deg
$\delta_0, \delta_1, \delta_2$	constants in profile drag coef- ficient expression	---
$\mu$	advance ratio	---
$\rho$	air density	slugs/ft <sup>3</sup>
$\sigma$	planform solidity ratio	---

<sup>1</sup>See the appendix I definition of  $M_{(1, 90)}$

<u>Item</u>	<u>Definition</u>	<u>Units</u>
$\psi$	rotor azimuth angle	deg
$\Omega$	rotor angular velocity	rad/sec

## INTRODUCTION

This paper reviews and expands a helicopter level flight performance data analysis procedure whose objective was to increase the Air Force Flight Test Center's (AFFTC's) capability of effectively analyzing rotary wing aircraft. The data analysis procedure under review was formulated by Dr. E. K. Parks of the University of Arizona and is presented in detail in reference 1. The rationale for reviewing this procedure was that technological advances have expanded the helicopters flight envelope into areas where current flight test analytic methods are at the limits of their capability for effectively presenting performance. A brief history of level flight helicopter testing at the AFFTC is presented below so the reader will become better acquainted with the problem and thus the content of this report.

In the past, helicopter level flight performance data was satisfactorily correlated by reducing the data to a nondimensional  $C_p$ ,  $C_T$ ,  $\mu$  relationship ( $C_p$  = power coefficient,  $C_T$  = thrust coefficient,  $\mu$  = advance ratio). Figure 5, appendix I, is an example of the  $C_p$ ,  $C_T$ ,  $\mu$  presentation. One of the basic assumptions of this method was that ambient temperature changes affected power required only through the air density

terms in the above mentioned dimensionless parameters. The ambient temperature influence on Mach number and consequently on the aerodynamic airfoil characteristics of the rotor blades was not considered an influencing factor due to the low airspeeds (80 to 100 knots) and low rotor tip speeds (600 to 650 ft/sec) associated with the older or reciprocating engine helicopter.

The AFFTC's flight tests on the turbine powered YH-40 helicopter in 1960 (reference 2) provided the first indication that some unaccountable parameters were influencing the level flight power required data. This was recognized through the lack of data correlation in the  $C_p$ ,  $C_T$ ,  $\mu$  presentation. Further data analysis showed that if the advancing blade tip Mach number ( $M_{TIP}$ ) was included as an additional variable, then satisfactory correlation could be attained in the level flight data. Subsequent test programs on higher performance helicopters (UH-1F, CH-3C, CH-47A) yielded data correlation problems of even greater magnitude than was experienced on the YH-40 test program. As a result of the data correlation problems encountered during the above mentioned programs and the requirement that these helicopters operate in extreme climatic conditions, special test programs were developed so that the performance of these helicopters were accurately defined. These special test programs included  $M_{TIP}$  as an integral and important part of the testing which dictated going to different geographical

areas for complete definition of the "Mach Effects." These programs were exploratory/empirical in nature and as a result had two intrinsic defects. They were:

1. Costly off-base testing at climatically suitable test areas.

2. Lengthy data reduction time which adversely influenced the report publication dates.

The test procedures developed during these programs are currently being used; however, successful completion of this study effort was to result in the minimizing of the above mentioned defects. An immediate goal was to develop the prescribed analytic procedure to the point where all the AFFTC's helicopter level flight testing could be conducted at the AFFTC, thereby eliminating the current need for off-base testing.

The flight test data used for this analysis was that of a CH-3C helicopter as reported in reference 3. The CH-3C helicopter built by Sikorsky Aircraft was an amphibious transport helicopter whose design gross weight was 19,500 pounds with a maximum alternate gross weight of 22,050 pounds. It was powered by two General Electric T58-GE-1

free turbine engines each of which had an uninstalled military rating of 1,250 shaft horsepower at sea level standard day. The main rotor system was all metal, five bladed and fully articulated. Each blade was 31 feet in length and had an NACA 0012 airfoil section. The CH-3C had a maximum airspeed of 144 knots indicated airspeed.

## EVALUATION

### GENERAL

As previously mentioned this report is an expansion of the effort of reference 1. The approach taken by reference 1 to determine a helicopter's level flight performance was to calculate individual power required terms, sum them to find the total power required and then compare these results with flight test results.

The approach used in this analysis is a modified reciprocal of the above technique and was changed for reasons of better compatibility with the flight test environment. These reasons will become apparent in the following discussion.

In classical helicopter analyses total power required in unaccelerated level flight is generally assumed equal to:

$$P_{ic} = P_i + P_{oi} + P_p$$

where,

$P_{ic}$  = incompressible power required

$P_i$  = induced power required

$P_{oi}$  = rotor blade profile power required (incompressible)

$P_p$  = fuselage parasite power required

or in coefficient form:

$$C_{pic} = C_{pi} + C_{poi} + C_{pp}$$

where,

$C_{pic}$  = incompressible power coefficient

$$C_{P_i} = \text{induced power coefficient} = 1/2 \frac{C_T^2}{\mu}$$

$$C_{P_{O_i}} = \text{profile power coefficient}$$

$$= \sigma \frac{\delta O}{8} + \frac{9}{2} \frac{\delta 2 C_T^2}{\sigma}$$

$$C_{P_p} = \text{parasite power coefficient}$$

$$= \frac{\mu^3}{2} \frac{f}{\pi R^2}$$

NOTE: See list of abbreviations and symbols and the appendix I for definition of symbols.

For this analysis two observations should be made regarding the constants and variables that make up  $C_{P_{ic}}$ :

1. The constants occur and remain fixed in all flow regimes.

2.  $C_T$  and  $\mu$  are composed of variables which are independent of the flow regime influences.

Therefore, for incompressible flow and excluding stall,  $C_{P_{ic}}$  can be expressed as a unique function of  $C_T$  and  $\mu$ . This relationship [ $C_{P_{ic}} = f(C_T, \mu)$ ] was successfully used in the past for presenting the level flight performance of a helicopter.

Current helicopters have rotor blade tip speeds and forward flight speeds that can cause the rotor to encounter compressibility and stall effects either separately or simultaneously. In analyzing a helicopter that has sufficient power to operate in this area, the power required equation must be changed to include terms for compressibility and stall thus:

$$C_p = C_{p_{oi}} + C_{pp} + C_{pi} + C_{ps} + C_{pc}$$

or

$$C_p = C_{pic} + C_{ps} + C_{pc}$$

where:

$C_{ps}$  = stall power coefficient

$C_{pc}$  = compressibility power coefficient

Correct formulation and application of  $C_{ps}$  and  $C_{pc}$  is the key to finding data correlation and is the crux of this report.

In flight test total power required ( $C_p$ ) is one of the parameters that is measured. It is also desirable that any corrections to this parameter be composed of terms made up of only measurable items or established correction terms. Since assumptions concerning the rotor motion, etc., must be made to arrive at the terms which make up  $C_{pic}$ , it was ascer-

tained that the power buildup approach would incur errors that would obscure any solutions within  $C_{p_s}$  and  $C_{p_c}$ . Therefore, the method of attack for this analysis was to calculate  $C_{p_s}$  and  $C_{p_c}$ , subtract the sum of these terms from a known flight test  $C_p$  and as a result establish the unique relationship,  $C_{p_{ic}} = f(C_T, \mu)$ . If this relationship could be established with a small variance from a norm then the method could confidently be used in actual flight test analyses. To further pursue this thought, if  $C_{p_{ic}}$  were established from data obtained only at the AFFTC, then the performance of a helicopter could be calculated for climatic conditions unavailable at the AFFTC rather than obtained through extensive off-base testing. This approach has its drawback, however, and that being complete dependence upon the accuracy with which flight test data can be measured. It was ascertained that a certain amount of scatter in the final presentation was due to the accuracy of the flight test data.

#### ADVANCING BLADE COMPRESSIBILITY CORRECTION

Based on the results and recommendations of reference 1, method four of that investigation was used to determine the power increment due to advancing blade compressibility ( $C_{p_c}$ ). Method four listed  $C_{p_c}$  as:

$$C_{p_c} = \sigma K (1 - M_{cr})_{TIP} [\psi = 90^\circ] (1 + \mu)^2 \left(1 - \frac{r_{cr}}{R}\right)^2 \quad (1)$$

where:

$K$  = variable constant

$M$  = blade section Mach number

$M_{cr}$  = blade section critical Mach number

$r_{cr}$  = blade radius outboard of which the blade section free stream Mach number is greater than the blade section local critical Mach number

$\sigma$  = planform solidity ratio

Several changes were made during this analysis from method four in the technique whereby  $\frac{r_{cr}}{R}$  and  $M_{cr}$  were determined. This was accomplished only after variation of the constants in the equations/techniques of method four yielded no significant improvement in data correlation. Listed below are the original equations used to arrive at  $\frac{r_{cr}}{R}$  and  $M_{cr}$  as compared to the final equations.

TABLE I  
Original Equations

$$\overline{C_l} (\psi = 90) = \frac{2C_T}{\sigma(1/3 + \mu + \mu^2)}$$

$$M_{cr} = K_1 - K_2 \overline{C_l} (\psi = 90)$$

$$\left(\frac{r_{cr}}{R}\right) (\psi = 90) = \frac{M_{cr}}{M_{TIP}} (1 + \mu) - \mu$$

### Final Equations

$$\bar{C}_l(\psi = 90) = \frac{AC_T^5 + BC_T^4 + CC_T^3 + \dots + F}{\sigma[1/3 + \mu + \mu^2]}$$

$$\frac{dC_l}{d\alpha} = f(M); \text{ (figure 2)}$$

$$\alpha = \frac{\bar{C}_l}{dC_l/d\alpha}$$

$$M_{cr} = K_1 - K_2\alpha; \text{ (figure 3)}$$

$$M_r(\psi = 90) = M_{TIP} \frac{(r + \mu R)}{(R + \mu R)}$$

$$\frac{r_{cr}}{R} = f(M_{cr}, M_r)$$

As may be observed the general procedure for arriving at  $M_{cr}$  and  $\frac{r_{cr}}{R}$  is the same, however, the final method was more rigorous and yielded more consistent results.

As shown in reference 4, for several inflow velocity conditions and assumptions the lift coefficient with respect to  $r$  and at  $\psi$  near 90 degrees is approximately constant. Therefore, a  $\bar{C}_l$  which is an average  $C_l$  with respect to  $R$

was defined for this analysis. In the appendix I  $\bar{C}_l$  was derived as a function of  $C_T$ ,  $\mu$  and  $\psi$  to be:

$$\bar{C}_l = \frac{2 C_T}{\sigma \{1/3 + \mu \sin \psi + \mu^2 \sin^2 \psi\}} \quad (2)$$

This equation was changed to:

$$\bar{C}_l = \frac{AC_T^5 + BC_T^4 + CC_T^3 + \dots + F}{\sigma (1/3 + \mu \sin \psi + \mu^2 \sin^2 \psi)} \quad (3)$$

after data checkout showed equation 2 would not give satisfactory results at high  $C_T$ 's (i.e., a stronger power correction as a function of  $C_T$  was needed).<sup>2</sup> This incorporation did not have the impact it was intended to; however, it did improve the data correlation and therefore was left in the analysis.

Expressing  $M_{CR}$  as a function of  $\bar{C}_l$  as in method 4 assumes that  $\frac{dC_l}{d\alpha}$  does not change with Mach number. This assumption was considered inconsistent with the development of this analysis and therefore the synthesized airfoil data of reference 5, page 17, was crossplotted into figure 2, whereby  $\frac{dC_l}{d\alpha}$  as a function of Mach number was determined. The lack of airfoil characteristics data in the transonic region greatly hindered the evaluation and remains a major stumbling block for any analyses.  $M_{CR}$  was defined as the Mach number at which the sloping drag rise line intersects the horizontal incompressible drag line for a given angle of attack. See figure 2a for a graphic presentation of  $M_{CR}$ . The empirical

<sup>2</sup>The coefficients A, B,....F were determined through curve fitting empirical fairings superimposed on equation (2) for base line purposes.

synthesized airfoil data of reference 5, page 19, was cross-plotted into figure 3 and shows the relationship of  $M_{cr}$  versus  $\alpha$  used in this report. Angle of attack ( $\alpha$ ) was found by:

$$\alpha = \frac{\bar{C}_l}{\frac{dC_l}{d\alpha}} \quad (4)$$

Calculation of  $\frac{r_{cr}}{R}$  was expanded from method four and was determined through a computer iteration process. The method four calculation of  $\left(\frac{r_{cr}}{R}\right)_{\psi = 90^\circ}$  was expressed as a function of  $\frac{M_{cr}}{M_{TIP}}$  where  $M_{cr}$  was based on the flow conditions at the tip of the blade. Since Mach number varies along the blade radius, each (dr) has its own critical Mach number making method four too approximate of a calculation. The final determination of  $\frac{r_{cr}}{R}$  calculated  $M_r$  at each blade radius and through an iterative procedure determined  $\frac{r_{cr}}{R}$  by comparison of  $M_r$  with an  $M_{cr}$  calculated from  $M_r$ . This procedure also improved the data correlation.

The compressibility corrected data resulting from the final chosen equations yielded curves of the classical  $C_p$ ,  $C_{p1}$ ,  $\mu$  form which implied the procedure was valid; however, the correction was not strong enough for the entire envelope of data considered, and therefore a stall correction was added.

From reviewing the results it was ascertained that reformulation of equation 1 is needed before better data correlation can be attained. Reformulation must be based on an analysis of compressibility effects around the entire 360 degrees of azimuth rather than only at  $\psi = 90^\circ$ . Use of methods 1 and 2 of reference 1 involves this approach and is undergoing analysis at this time.

#### RETREATING BLADE STALL CORRECTION

The equation used to calculate the power increment due to retreating blade stall ( $C_{ps}$ ) was:

$$C_{ps} = \frac{\sigma}{24\pi} (1 - \mu)^2 (1 - x_s) \sqrt{1 - x_s^2} \quad (5)$$

where:

$\sigma$  = planform solidity ratio

and

$x_s = \frac{r_s}{R}$ , where  $r_s$  is the blade radius outboard of which the blade is stalled

This equation is presented in references 1 and 6 and is derived as an estimation to the stall power required increment in reference 7.

For the retreating portion of the rotor azimuth a uniform inflow condition was assumed to exist. This assumption

shows  $C_L = \frac{r}{R}$  (reference 4) on the retreating portion of the azimuth and is consistent with the procedure chosen for calculating  $\frac{r_s}{R}$ . As in the compressibility section the recommended equations of reference 1, method four, are shown below compared to the final equations used for this paper.

TABLE II

Original Equations

$$C_L(\psi = 270^\circ) = \frac{2C_T}{\sigma(1/3 - \mu + \mu^2)}$$

$$C_{L_{\max}} = K_3 - K_4 M_{TIP}(\psi = 270^\circ)$$

$$\frac{r_s}{R} = \left( \frac{C_{L_{\max}}}{C_L} \right)_{TIP} [\psi = 270^\circ]$$

Final Equations

$$C_L(\psi = 270^\circ) = \frac{r}{R} \frac{2C_T}{\sigma(1/4 - 2/3 \mu + 1/2 \mu^2)} \quad (6)$$

$$M_r(\psi = 270^\circ) = M_{TIP}(1, 270) \frac{[r - \mu R]}{[R - \mu R]} \quad (7)$$

$$C_{L(\max)} = K_5 - K_6 M - (\text{figure 4}) \quad (8)$$

$$\frac{r_s}{R} = f \text{ (equations: 6, 7 and 8)}$$

see appendix I derivation

Assuming  $C_L \propto \frac{r}{R}$ ,  $C_L$  can be shown to be equal to:

$$C_L = \frac{r}{R} \frac{2C_T}{\sigma(1/4 + 2/3 \mu \sin\psi + 1/2 \mu^2 \sin^2\psi)} \quad (6)$$

(see appendix I derivation)

$C_{L_{max}}$  as a function mach number was determined from the synthesized airfoil data of reference 5, page 17, and was crossplotted into figure 4, appendix I. By use of the uniform inflow equation for  $C_L$  (equation 6),  $\frac{r_s}{R}$  can be calculated directly by solving equations (6), (7) and (8) simultaneously for  $\frac{r}{R}$ ;  $r$  then becomes  $r_s$  for the definition of  $r_s$  occurring with  $C_{L_{max}}$ .

Equation 5 was found to yield too gross a stall power correction for most of the flight envelope. For a constant  $\mu$ , and  $C_p = f(C_T, M_{TIP})$ ,  $C_{p_s}$  was too gross for low and medium  $C_T$ 's when adjusted to give an adequate correction to the higher  $C_T$ 's and likewise when  $C_{p_s}$  was adjusted to give adequate values for the lower and medium  $C_T$ 's too meager a value was calculated for the higher  $C_T$ 's.

As for the compressibility correction, reformulation of equation 5 is needed rather than redefinition of procedure in order to obtain more precise values of  $C_{p_s}$ . For this to occur

more exact airfoil data is also needed so that  $C_{l_{max}} = f(M, \alpha, Re)$  can be accurately defined.

## RESULTS

Observing figures 6 through 12 is the best way to analyze the results of this paper. The range of  $\mu$ 's chosen for figures 6 through 12 ( $\mu = .14$  to  $.36$ ) adequately covers the low speed and high speed flight regime of the CH-3C helicopter. The solid lines on these plots are the power required curves as determined from flight test (reference 3); the symbols are the location of  $C_{pic}$  points after subtracting  $C_{ps}$  and  $C_{pc}$  from the flight test curves; and the dashed line is  $C_{pic}$  as determined by the author through a crossplotting technique. These curves are shown as a family in figure 5.

If for the entire flight envelope a maximum  $\Delta C_p$  of  $1 \times 10^{-5}$  could be established as the confidence band of the  $C_{pic}$  points then the data analysis procedure would be considered valid and could be used to calculate power required for flight conditions where testing was not accomplished. Figures 6 through 12 show that the  $\Delta C_p$  of  $1 \times 10^{-5}$  requirement was met for approximately 80 percent of flight envelope checked; however, the remaining 20 percent is the area of most interest and a solution must be found for this area before it can be applied in practice. The 20 percent where data resolution

could not be attained generally occurred at the higher values of  $\mu$ , at high values of  $C_T$  and at high  $M_{TIP}$ 's.

A  $C_{pic}$  line was constructed on each of figures 6 to 12. This was determined by continuing the line where  $C_{pic}$  is substantiated (same  $C_p$  for a given  $\mu$  and  $C_T$  but several  $M_{TIP}$ 's) and then crossplotting these curves to give a smooth family of curves (figure 5).  $C_{ps}$  and  $C_{pc}$  was then calculated using the final equations in this report for the conditions of figures 13 through 22, added to  $C_{pic}$  from figure 5 and then plotted on figures 13 through 22. Here a direct comparison of actual level flight speed power points and the values determined using  $C_p = C_{pic} + C_{ps} + C_{pc}$  is made. For comparison there are five sets of data, each comprised of two plots at a given  $C_T$ , but with two different  $M_{TIP}$ 's for a given  $\mu$ . Once again correlation is satisfactory except for combinations of high  $C_T$ ,  $\mu$  and  $M_{TIP}$ . Although 100 percent data correlation was not attained, the analysis confirmed that an analytic approach is feasible and could result in a substantial savings in flight test time and costs.

## CONCLUSIONS AND RECOMMENDATIONS

The analytic approach taken during this study effort to arrive at a method for effectively determining and predicting the level flight performance of a helicopter was considered to have merit. Satisfactory data correlation was attained between the calculated and flight test data for approximately 80 percent of the envelope checked. It was deduced that reformation of the  $C_{pC}$  and  $C_{pS}$  equations is necessary before further improvement in data correlation can be realized.

The lack of available aerodynamic airfoil characteristics data for an NACA 0012 airfoil in the transonic region hindered the development of this study effort. Obtaining of these data is also considered necessary before significantly improved results can be realized. The overall aims of this analysis were met and further studies are recommended.

## APPENDIX I

This section explains the common terminology used in this report, derives the major equations, and presents the plots used in the analysis.

### TERMINOLOGY

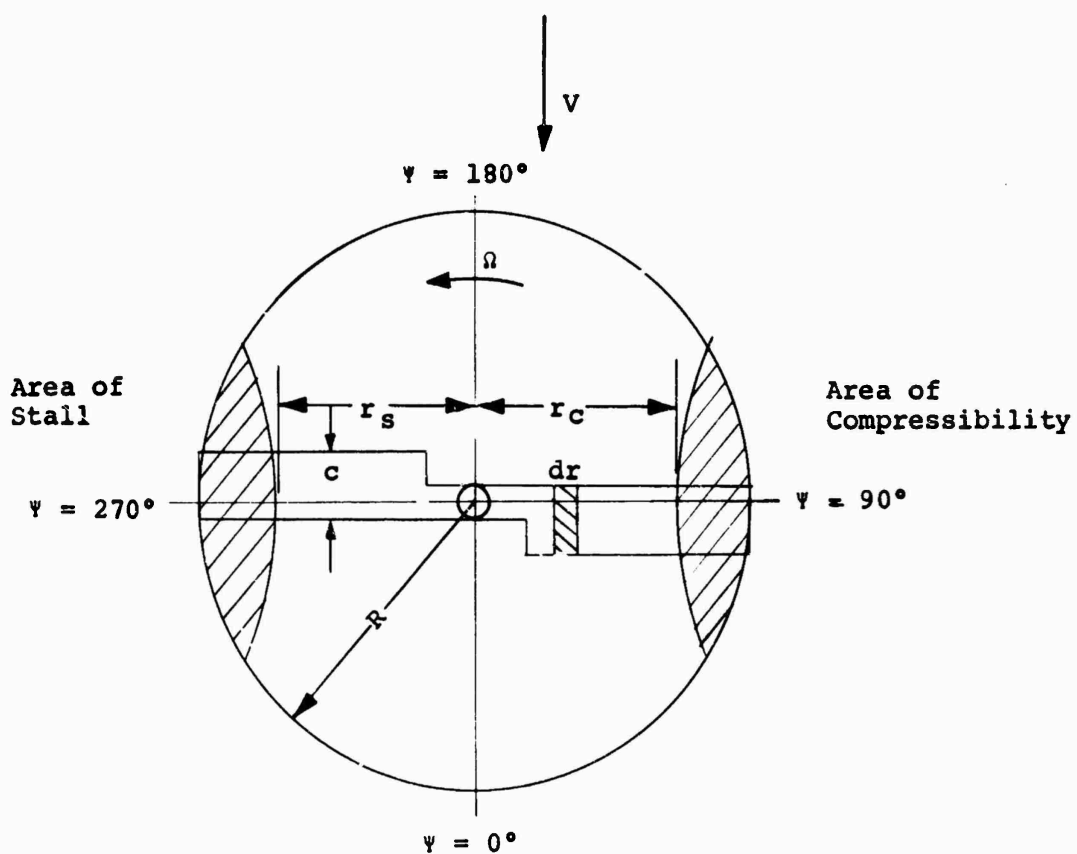

Figure 1. General Rotor Nomenclature

$$C_T = \text{thrust coefficient} = \frac{W}{\rho \pi R^2 (\Omega R)^2}$$

$$C_p = \text{power coefficient} = \frac{550 \text{ SHP}}{\rho \pi R^2 (\Omega R)^3}$$

$$\mu = \text{advance ratio} = \frac{V_t}{\Omega R}$$

$$\sigma = \frac{b c R}{\pi R^2} = \text{planform solidity ratio}$$

b = number of blades

c = rotor blade chord

$$M_{TIP} = M(1, 90) = \frac{V_t + \Omega R}{K \sqrt{T}}$$

In the subscript (1, 90) the first number refers to the blade radius location in percent R and the second number refers to the rotor blade azimuth angle.

#### DERIVATION OF MAJOR EQUATIONS

I:

$$\bar{C}_l = f(\psi, \mu, C_T)$$

$$dL = 1/2 \bar{C}_l \rho [\Omega r + V \sin \psi]^2 c \, dr$$

$$L = 1/2 \rho \bar{C}_l c \int_0^R (\Omega r + V \sin \psi)^2 \, dr$$

$$L = c/2 \bar{C}_L \rho (1/3 \omega^2 R^3 + \mu V R^2 \sin \psi + V^2 R \sin^2 \psi)$$

$$DL = W; C_T = \frac{W}{\rho \pi R^2 (\omega R)^2}; \sigma = \frac{DC}{\omega R}; \mu = \frac{V}{\omega R}$$

$$\bar{C}_L = \frac{2C_T}{\sigma [1/3 + \mu \sin \psi + \mu^2 \sin^2 \psi]}$$

II:

$$C_L = f(\psi, \mu, C_T) \text{ where } C_L \propto \frac{r}{R} \text{ or } C_L = k \frac{r}{R}$$

$$dL = 1/2 \frac{\rho c}{R} (\omega r + V \sin \psi)^2 c r dr$$

$$L = 1/2 \frac{\rho c c}{R} \int_0^R (\omega r + V \sin \psi)^2 r dr$$

$$L = 1/2 \rho c c \left( \frac{\omega^2 R^3}{4} + 2/3 \omega R^2 V \sin \psi + 1/2 R V^2 \sin^2 \psi \right)$$

$$k = \frac{2C_T}{\sigma (1/4 + 2/3 \mu \sin \psi + \frac{\mu^2 \sin^2 \psi}{2})}$$

$$C_L = \frac{r}{R} \frac{2C_T}{\sigma (1/4 + 2/3 \mu \sin \psi + \frac{\mu^2 \sin^2 \psi}{2})}$$

III:

$$\text{Assume: } C_L = k \frac{r}{R}$$

and

$$C_{L_{\max}} = K_3 - K_4 M$$

when  $C_2 = C_{2\max}$   $r = r_s$

therefore:

$$K_3 - K_4M = k \frac{r_s}{R}$$

$$M(r, 270) = M(1, 270) \frac{[r - \mu R]}{[k - \mu k]}$$

$$K_3 - K_4M(1, 270) \frac{[r - \mu R]}{[R - \mu R]} = k \frac{r_s}{R}$$

See derivation II for  $k$  then combining terms:

$$\frac{r_s}{R} = \frac{K_3 - K_3\mu + K_4\mu M(1, 270)}{K(1 - \mu) + K_4M(1, 270)}$$

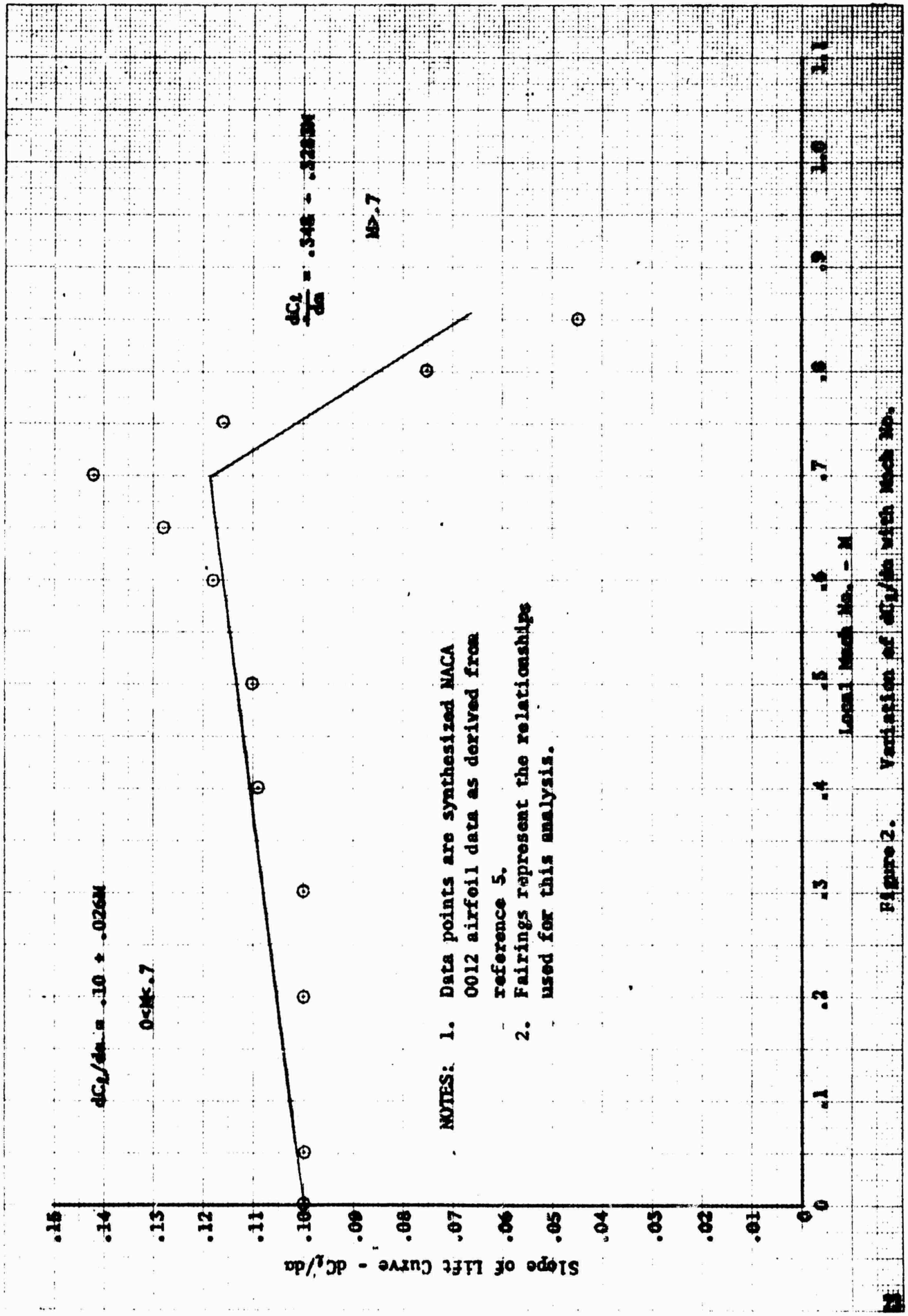

- NOTES:
1. Data points are synthesized NACA 0012 airfoil data as derived from reference 5.
  2. Fairings represent the relationships used for this analysis.

Figure 2. Variation of  $dC_l/d\alpha$  with Mach No.

- NOTES: 1. Fairings obtained from reference 5.  
 2. Symbols denote  $M_{cr}$  as defined on page 11. (Also see figure 3)

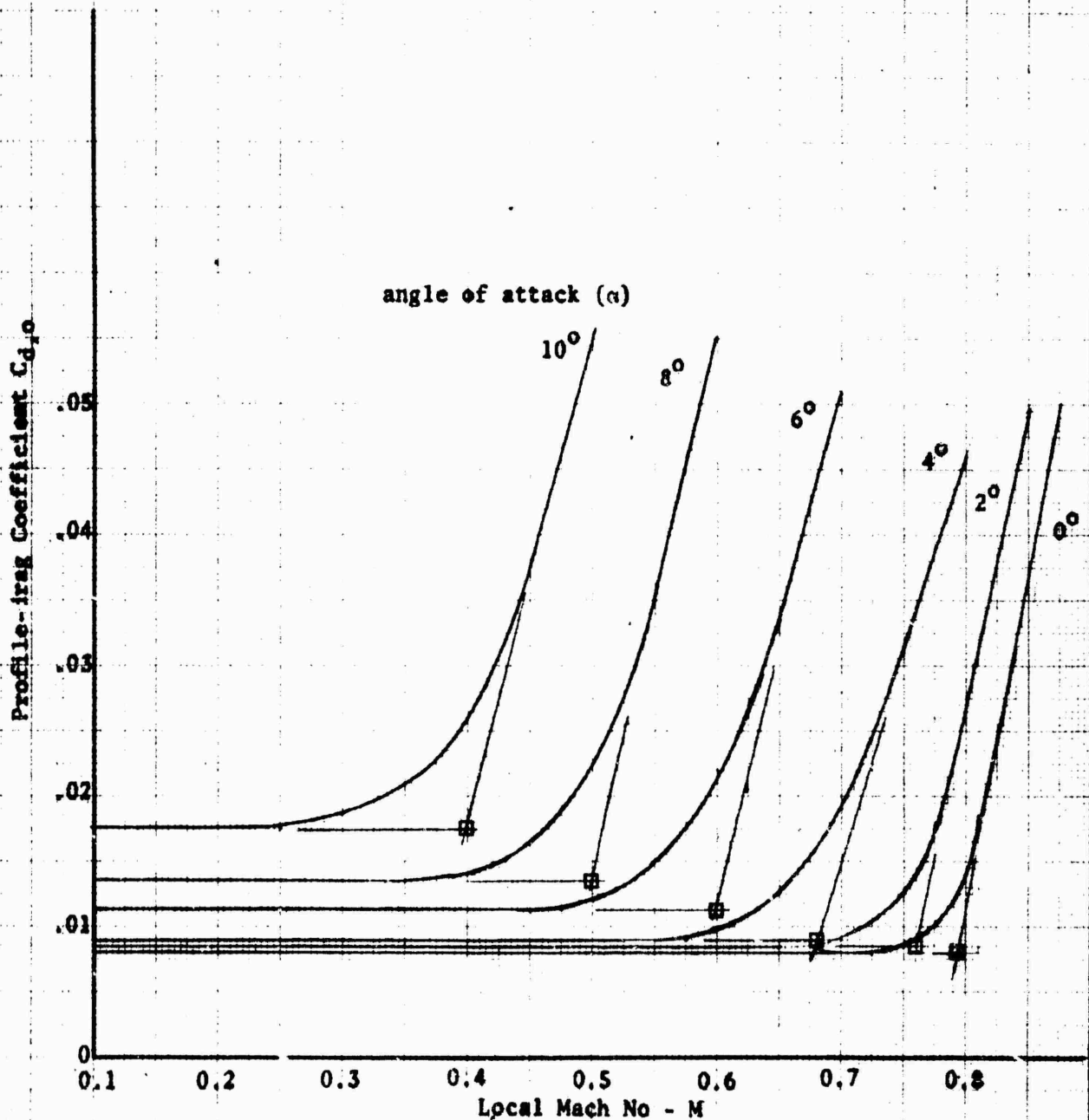

Figure 2a. Profile-drag Coefficient versus Mach No.

- NOTES: 1. Data points are synthesized MACA  
 NACA 0012 airfoil data as derived  
 from reference 5. (See Figure 2a.)
2.  $M_{cr}$  for this plot is defined on  
 page 11

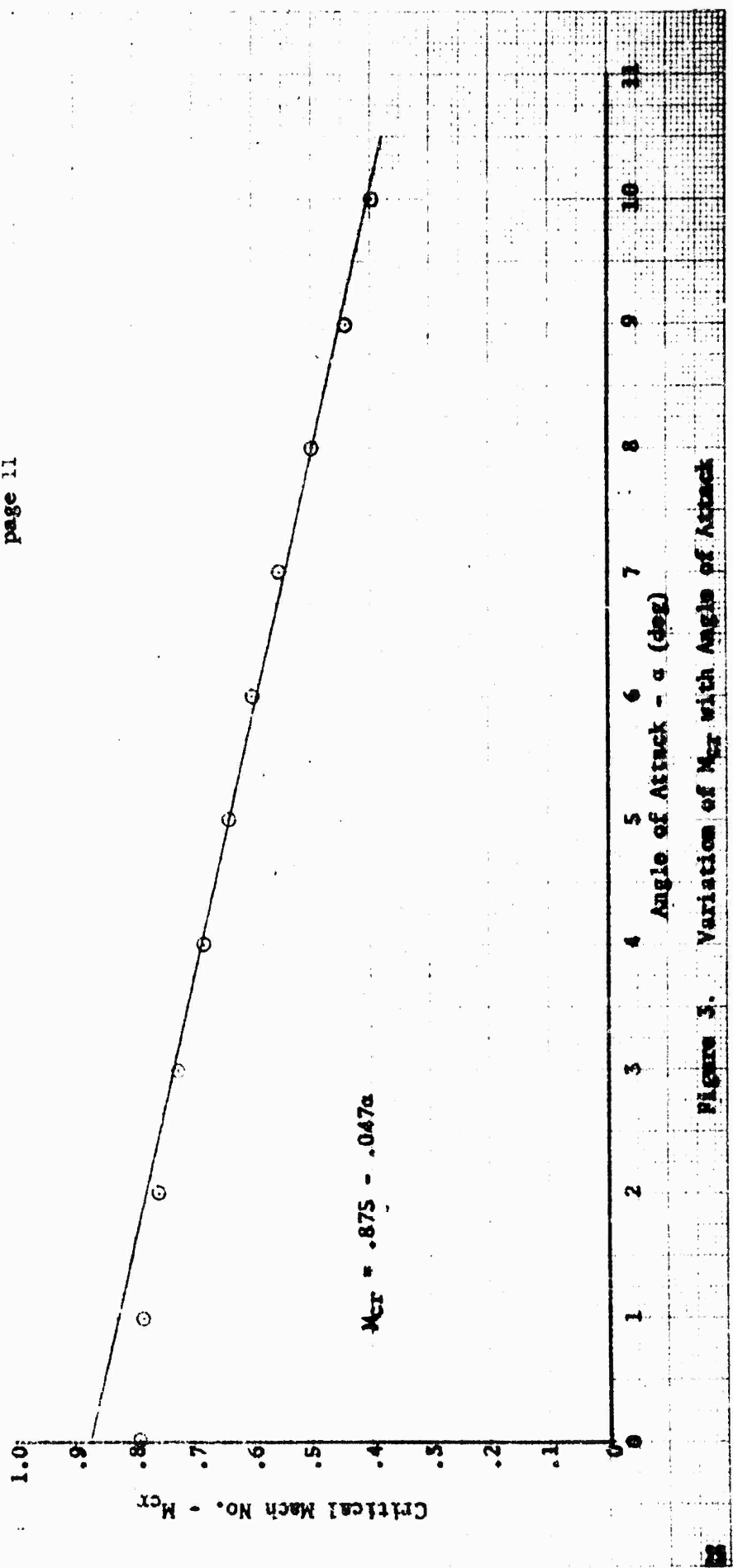
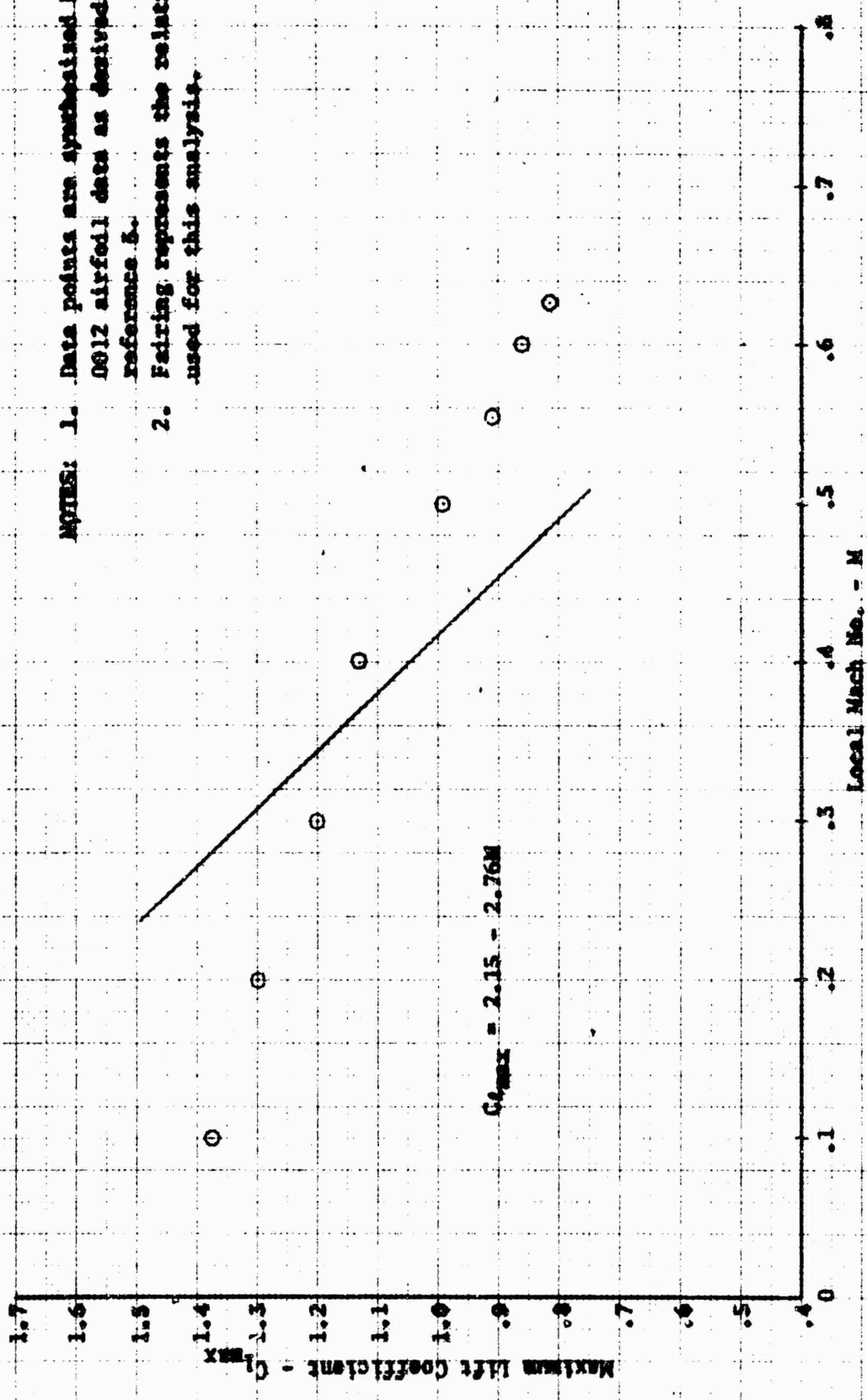

Figure 3. Variation of  $M_{cr}$  with Angle of Attack



- NOTES: 1. Data points are synthesized MACA 0012 airfoil data as derived from reference 5.
2. Fairing represents the relationship used for this analysis.

Figure 4. Variation of  $C_{l_{max}}$  with Mach No.

OH-35 Helicopter

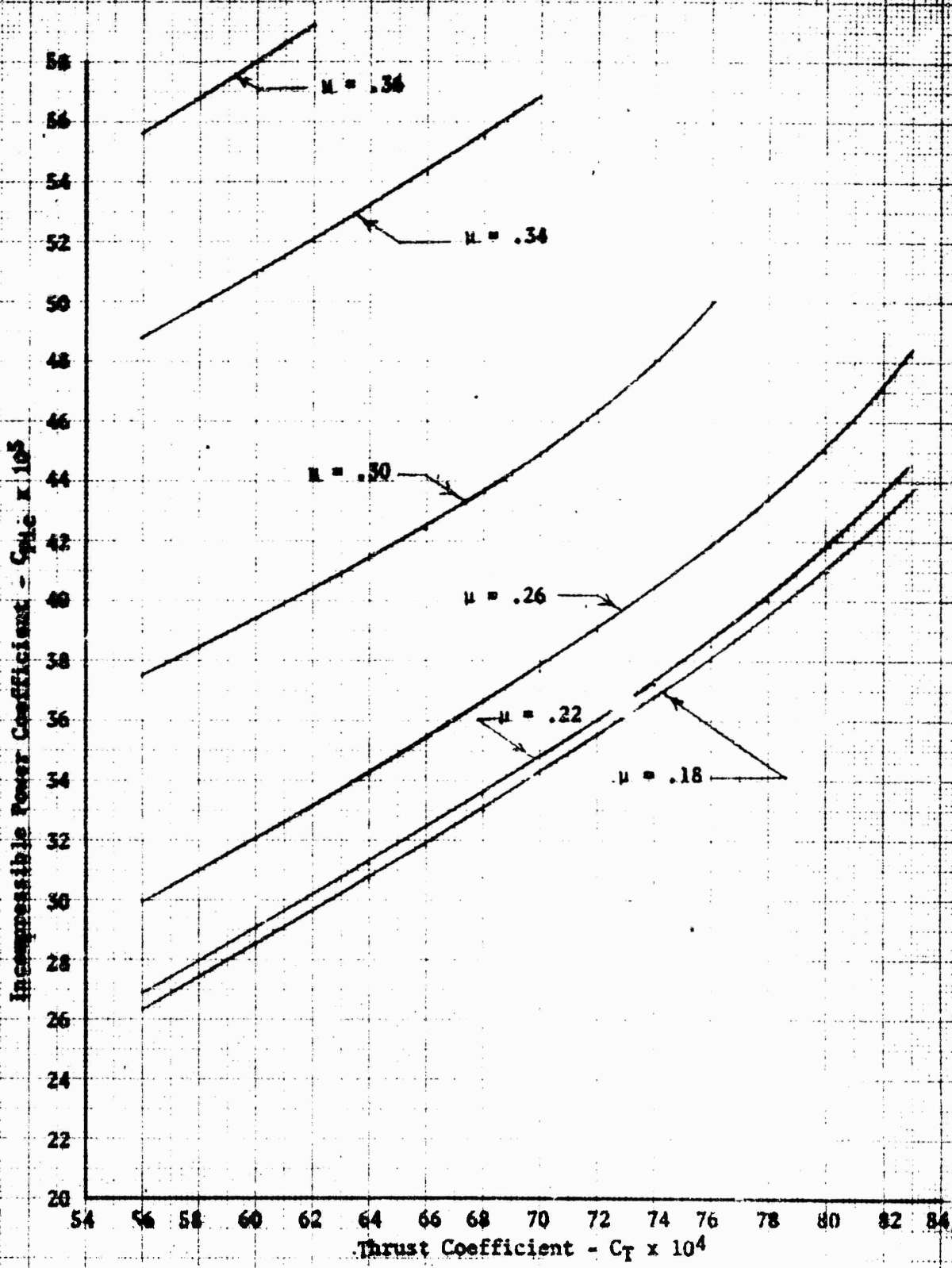

Figure 5. Incompressible Level Flight Performance

CH-3E Helicopter

$\mu = .14$

- NOTES: 1. Solid lines represent flight test power required data as presented in reference 3.  
 2. Dashed line represents incompressible power required as determined from calculation and cross plotting.  
 3. Symbols represent incompressible power required determined from  $C_{Pic} = C_p - C_{Pc} - C_{Ps}$

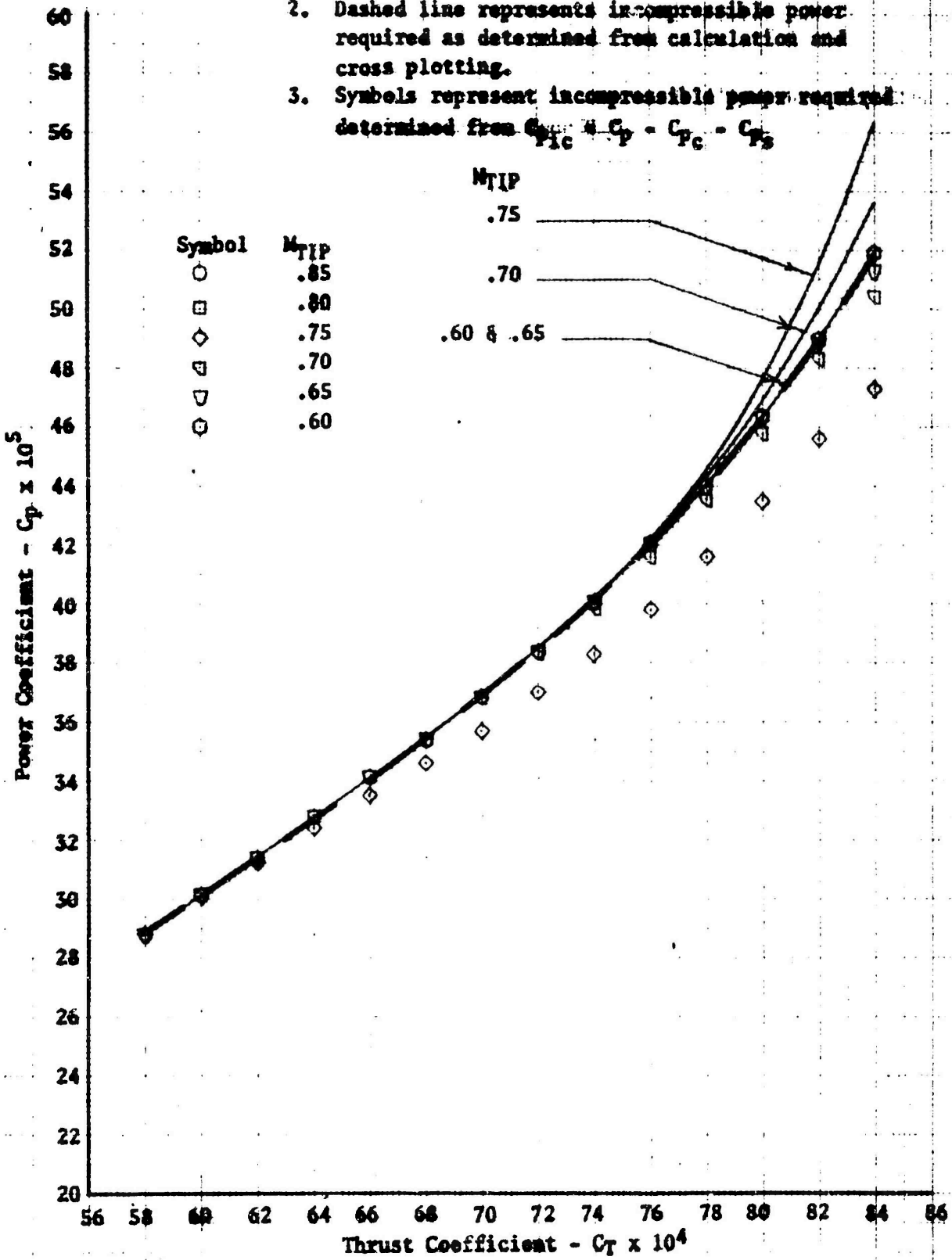

Figure 6. Nondimensional Level Flight Performance

CH-3E Helicopter

$\mu = .18$

- NOTES: 1. Solid lines represent flight test power required data as presented in reference 3.  
 2. Dashed line represents impossible power required as determined from calculation and cross plotting.  
 3. Symbols represent impossible power required determined from  $C_{p_{ic}} = C_p - C_{p_c} - C_{p_s}$ .

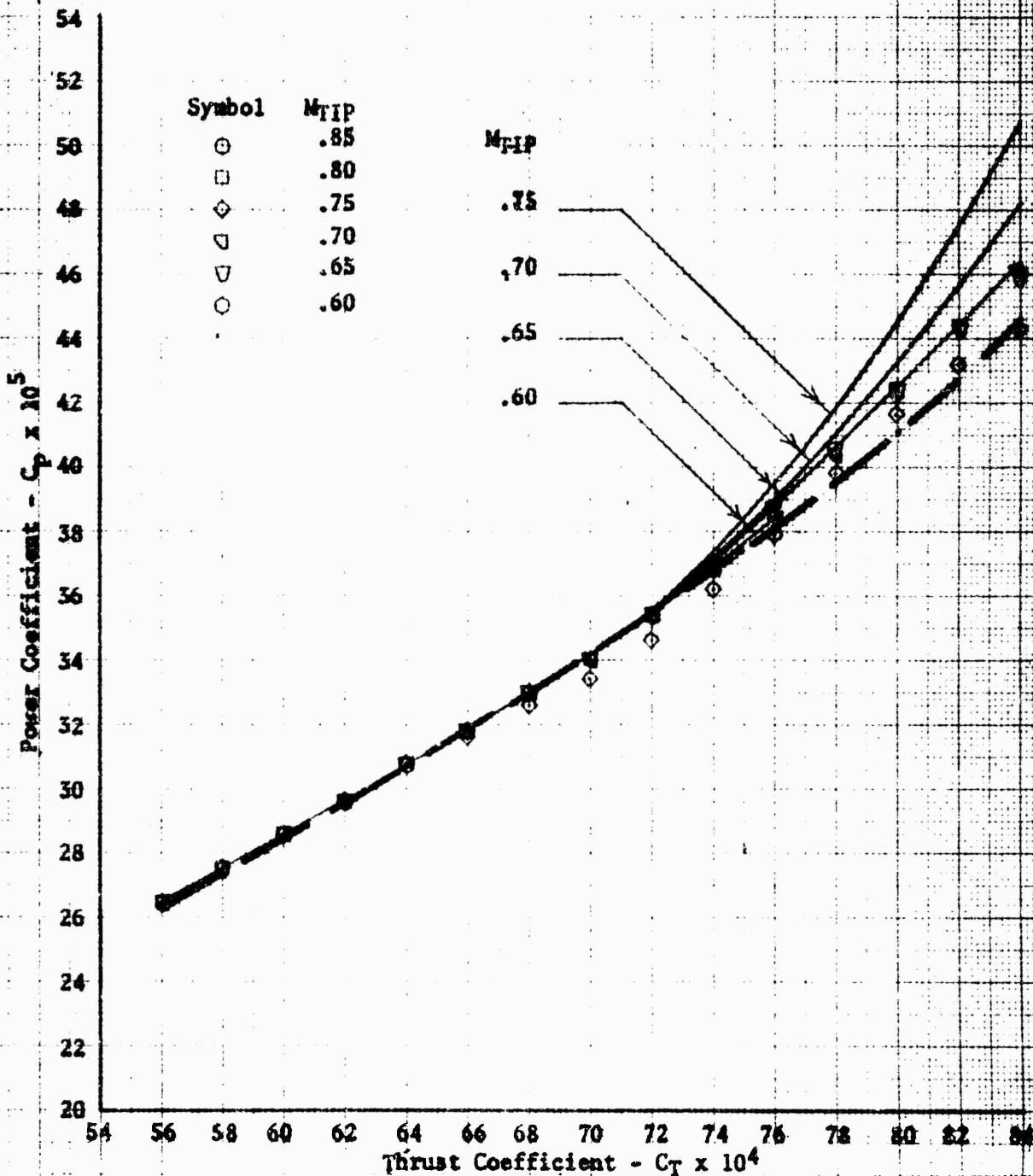

Figure 7. Nondimensional Level Flight Performance

CH-53 Helicopter

$\mu = .22$

- NOTES: 1. Solid lines represent flight test power required data as presented in reference 1.  
 2. Dashed line represents incompressible power required as determined from calculation and cross plotting.  
 3. Symbols represent incompressible power required determined from  $C_{P_{IC}} = C_p = C_{P_C} = C_{P_S}$ .

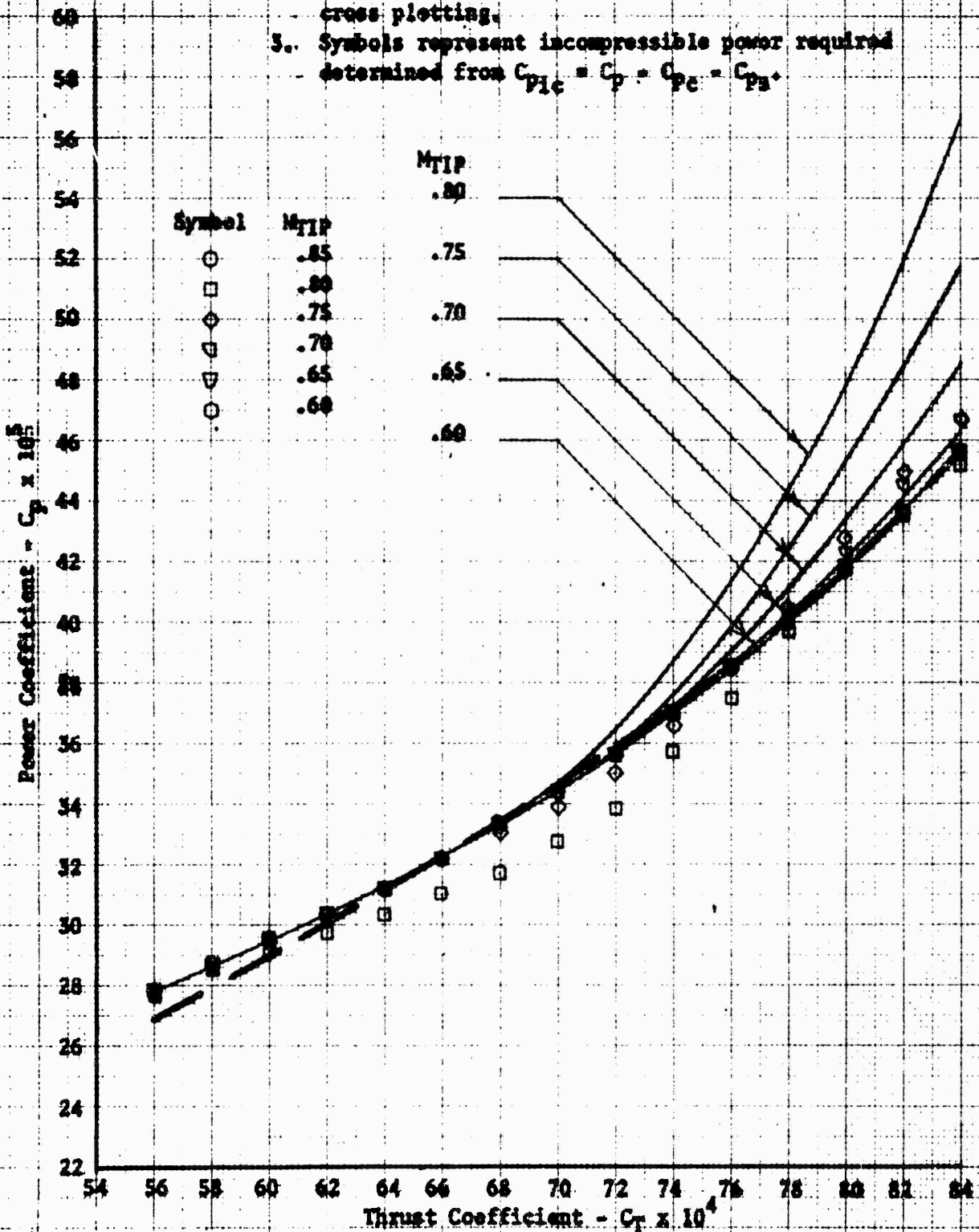

Figure 3. Nondimensional Level Flight Performance.

CH-53 Helicopter

$\mu = .26$

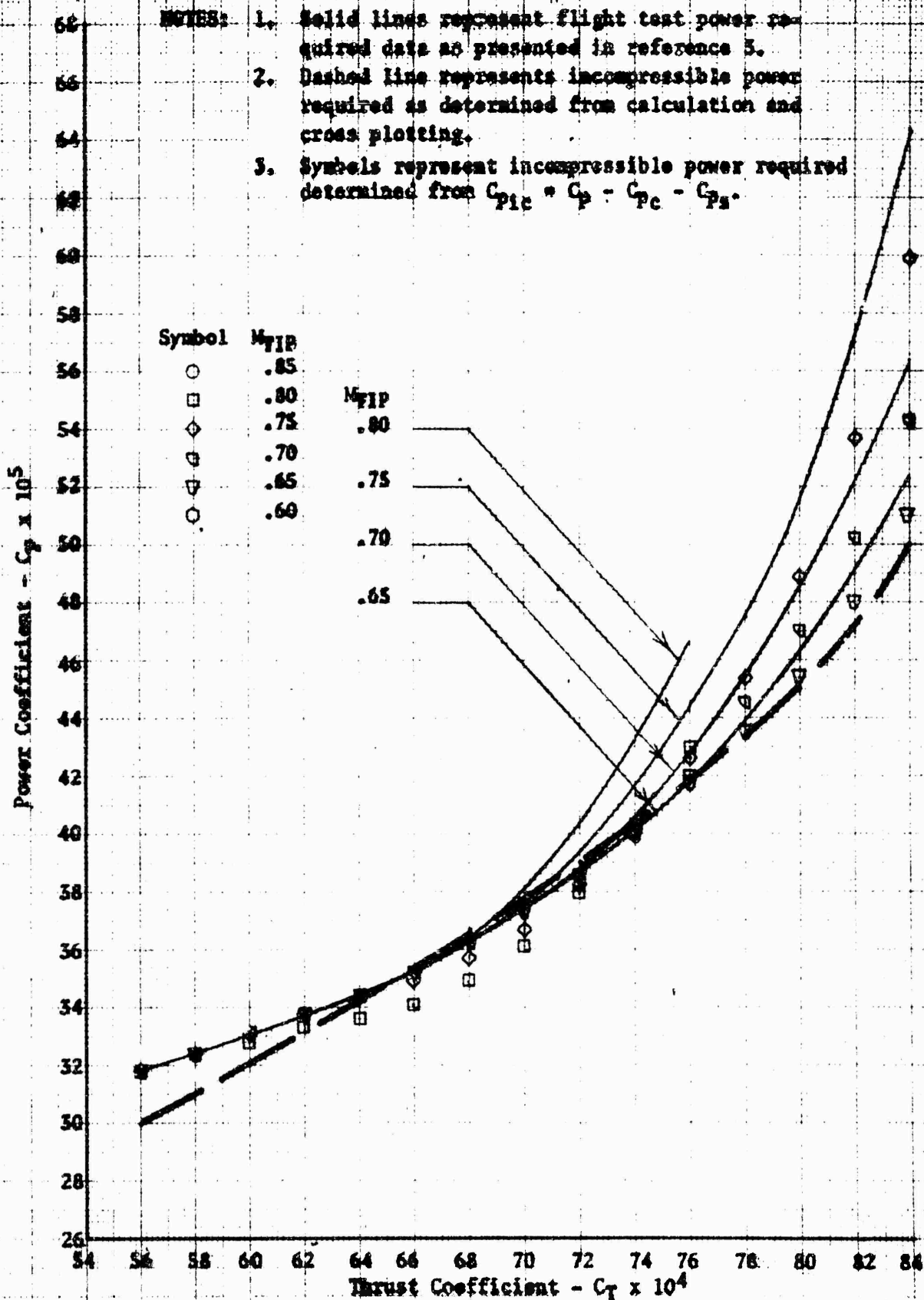

Figure 9. Nondimensional Level Flight Performance

CH-3E Helicopter

$\mu = .30$

- NOTES: 1. Solid lines represent flight test power required data as presented in reference 3.  
 2. Dashed line represents incompressible power required as determined from calculation and cross plotting.  
 3. Symbols represent incompressible power required determined from  $C_{pic} = C_p - C_{pc} - C_{ps}$ .

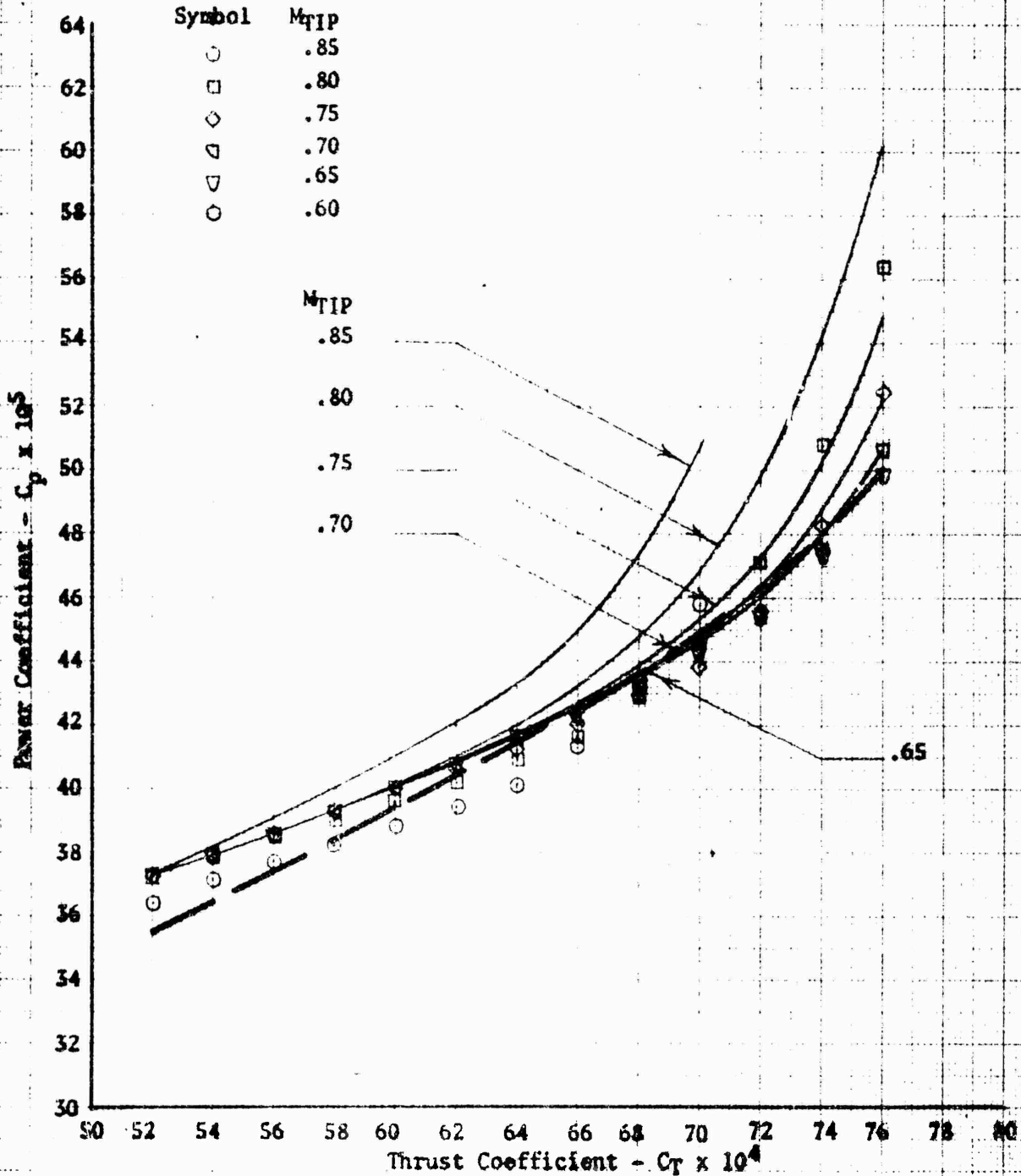

Figure 10. Nondimensional Level Flight Performance

OH-35 Helicopter

1 \* 104

- NOTES: 1. Solid lines represent flight test power required data as presented in reference 3.  
 2. Dashed line represents incompressible power required as determined from calculation and cross plotting.  
 3. Symbols represent incompressible power required determined from  $C_{pic} = C_p - C_{pc} - C_{ps}$ .

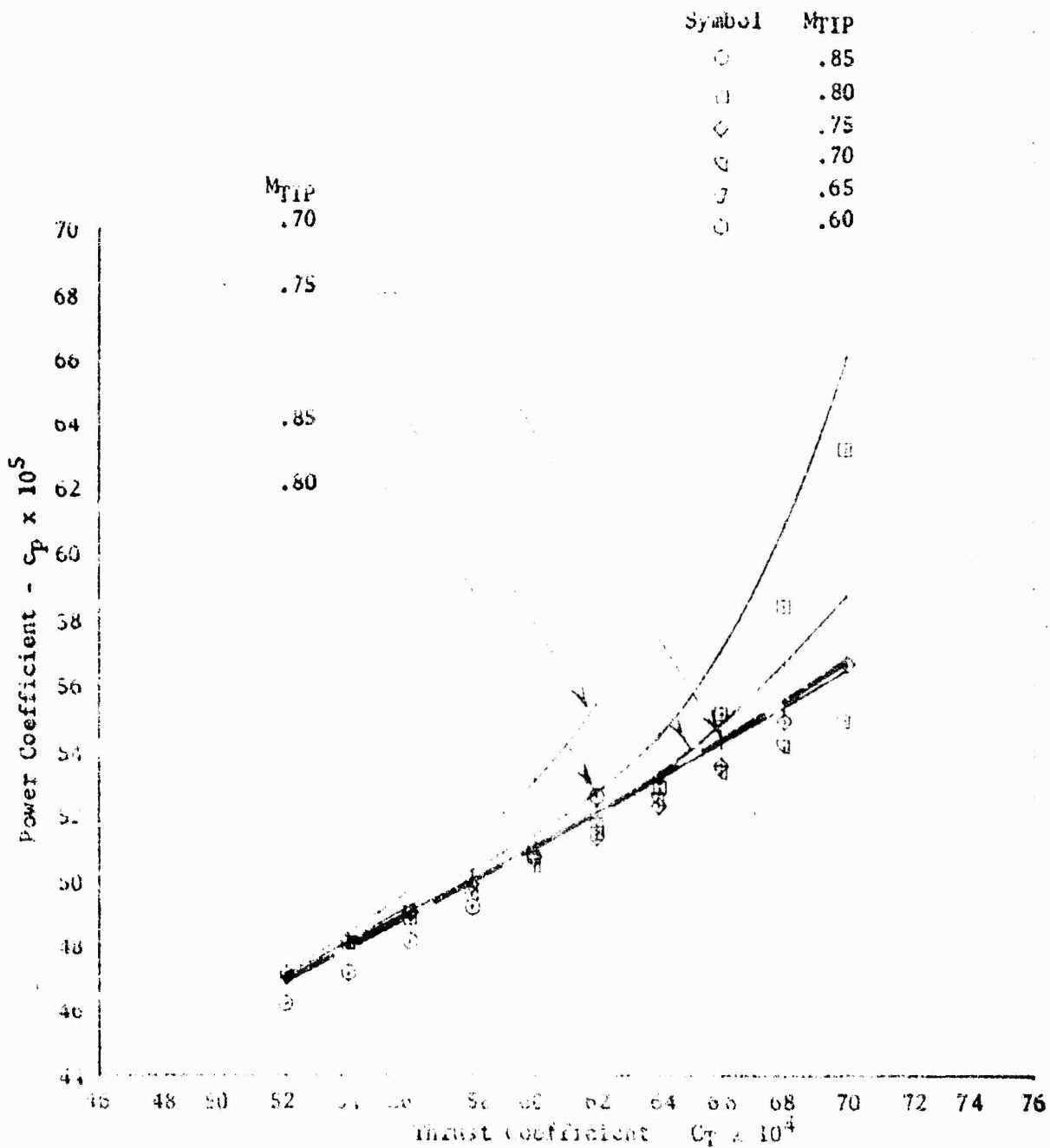

Figure 11. Semirandom level flight performance

# CH-3E Helicopter

$\mu = .36$

- NOTES:
1. Solid lines represent flight test power required data as presented in reference 3.
  2. Dashed line represents incompressible power required as determined from calculation and cross plotting.
  3. Symbols represent incompressible power required determined from  $C_{pic} = C_p - C_{pc} - C_{ps}$ .

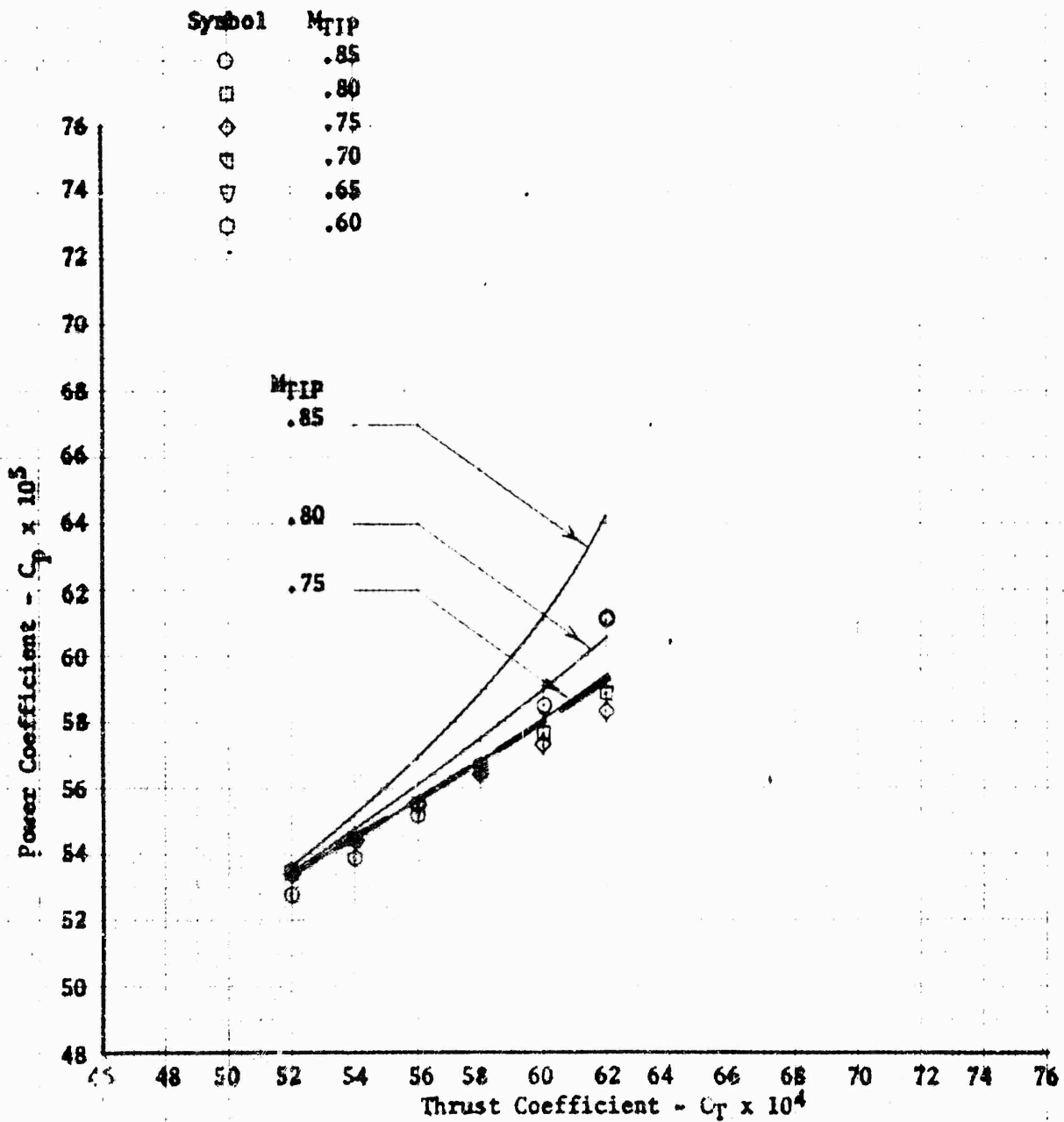

Figure 12. Nondimensional Level Flight Performance

CH-3E Helicopter

$C_T = .00513$

- NOTES: 1. Open symbols and fairings denote flight test data as presented in reference 3.  
 2. Solid symbols are calculated data using

$C_P = C_{P_{ic}} + C_{P_c} + C_{P_s}$

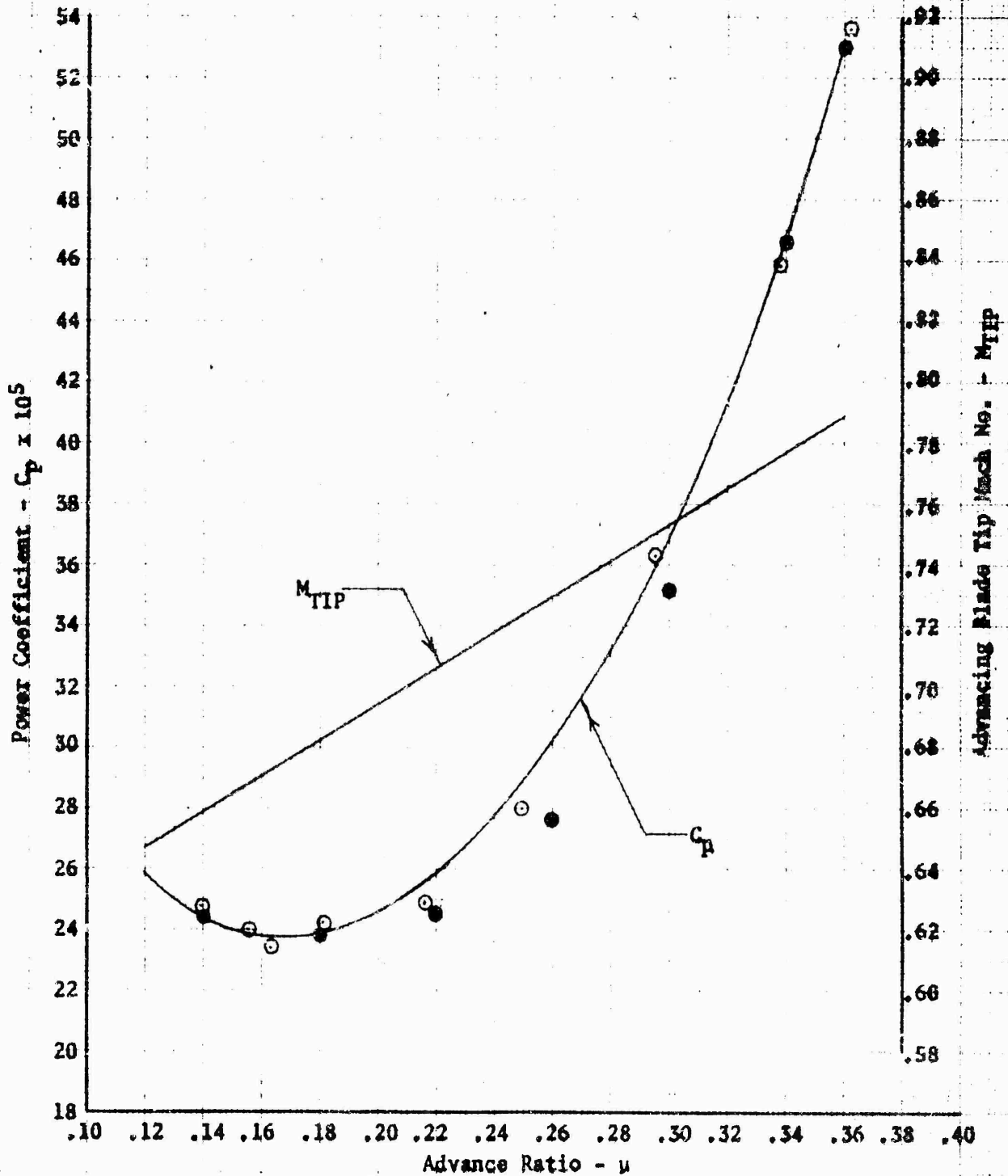

Figure 13. Level Flight Performance

CH-3E Helicopter

$C_T = .00513$

- NOTES: 1. Open symbols and fairings denote flight test data as presented in reference 5.  
 2. Solid symbols are calculated data using  
 $C_p = C_{p_{ic}} + C_{p_c} + C_{p_s}$

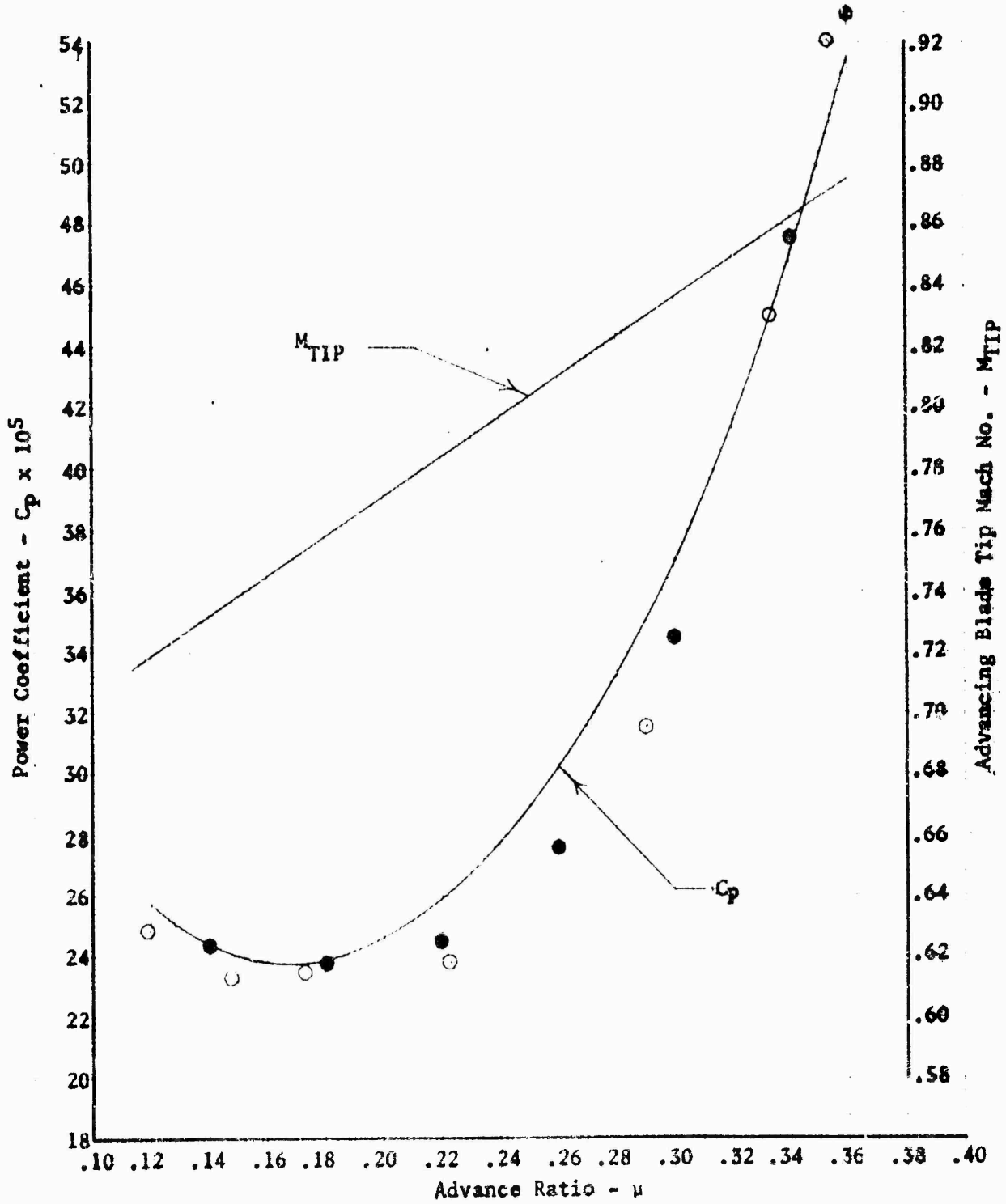

Figure 14. Level Flight Performance

CH-3E Helicopter

$$C_T = .00626$$

- NOTES: 1. Open symbols and fairings denote flight test data as presented in reference 3.  
 2. Solid symbols are calculated data using

$$C_P = C_{P_{ic}} + C_{P_c} + C_{P_s}$$

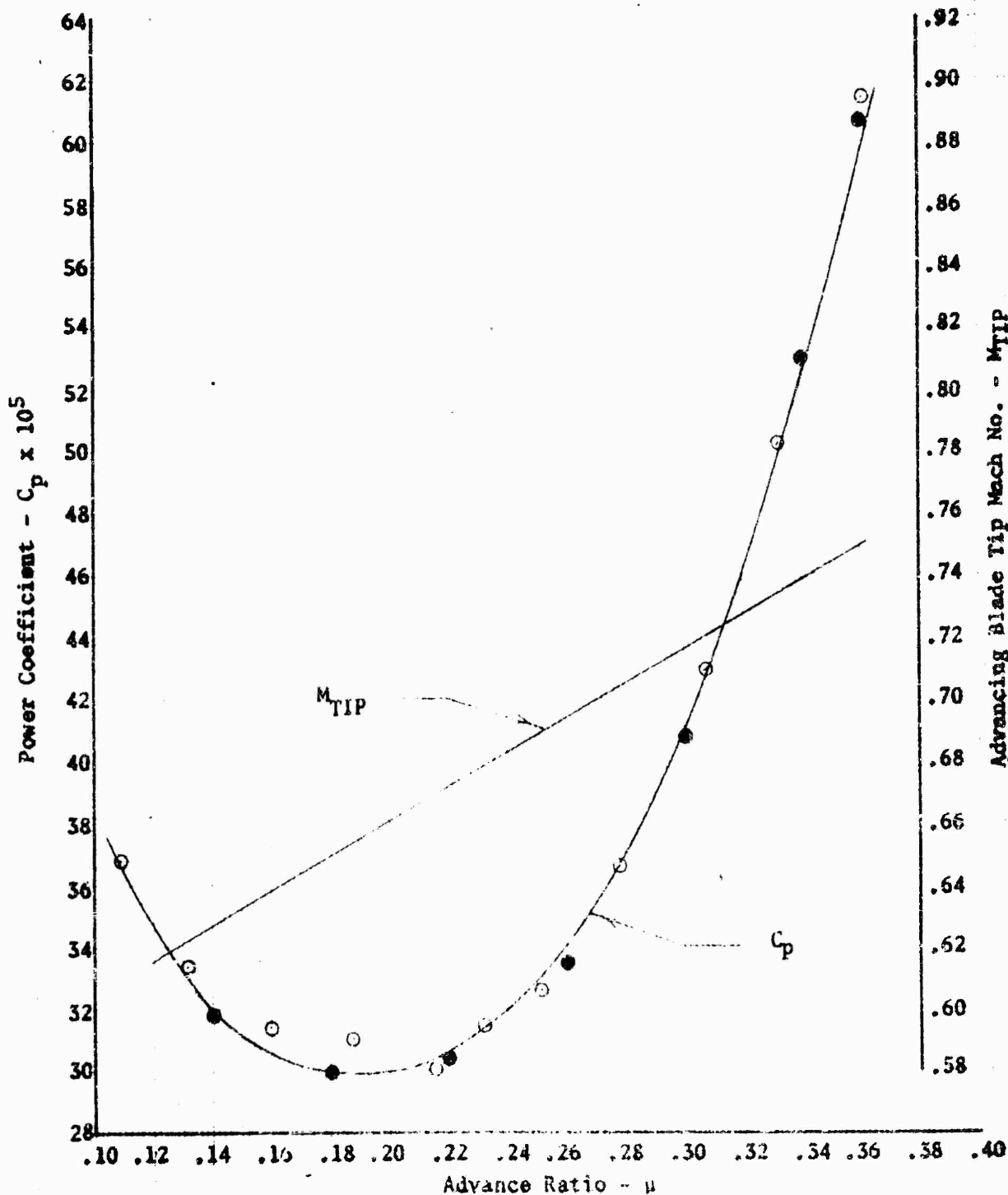

Figure 15. Level Flight Performance

OH-38 Helicopter

$C_T = .00626$

- NOTES: 1. Open symbols and fairings denote flight test data as presented in reference 3.  
 2. Solid symbols are calculated data using

$C_p = C_{pic} + C_{pc} + C_{ps}$

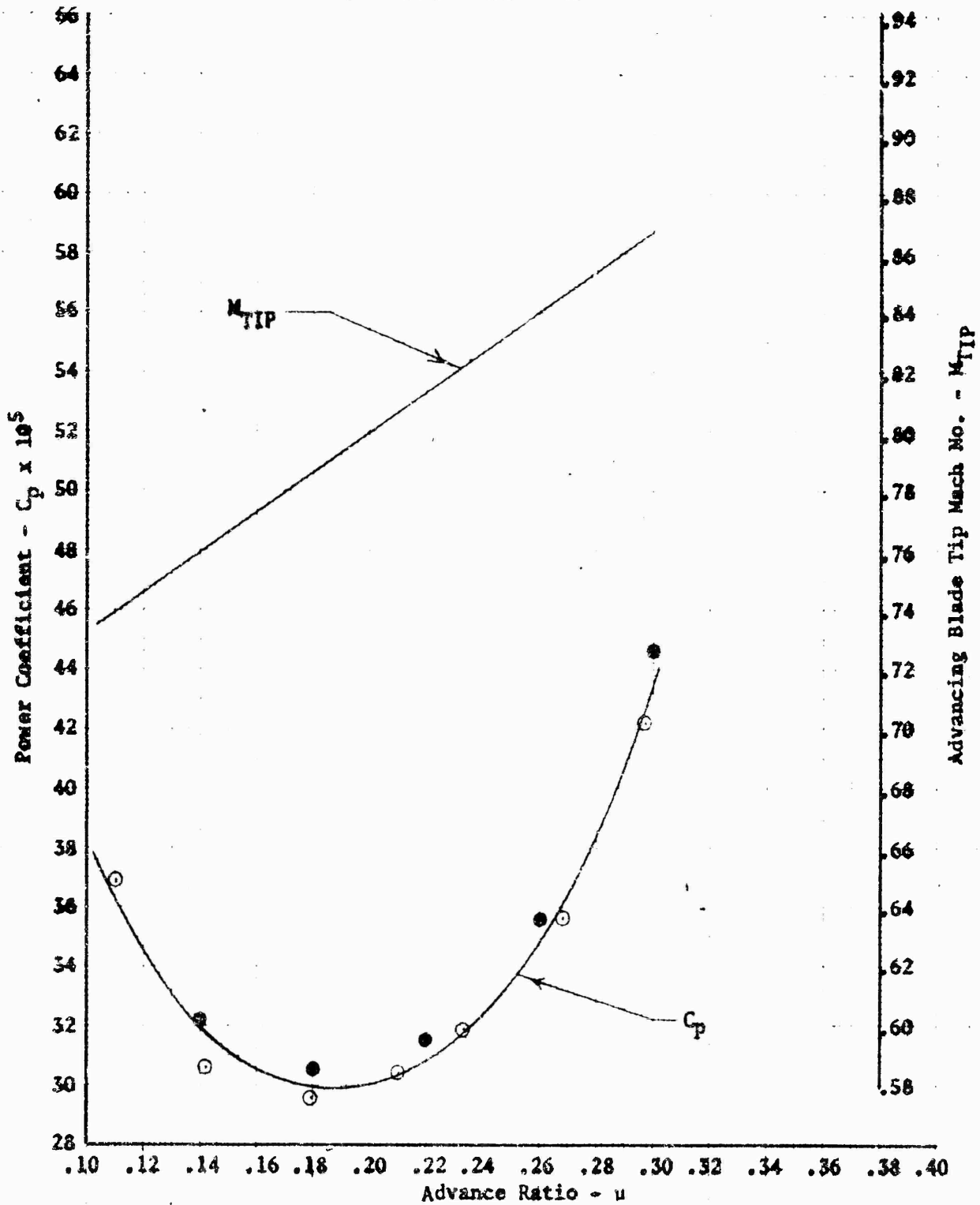

Figure 16. Level Flight Performance

UH-3E Helicopter

$C_T = .00710$

- NOTES: 1. Open symbols and fairings denote flight test data as presented in reference 3.  
 2. Solid symbols are calculated data using  $C_p = C_{p_{ic}} + C_{p_c} + C_{p_s}$

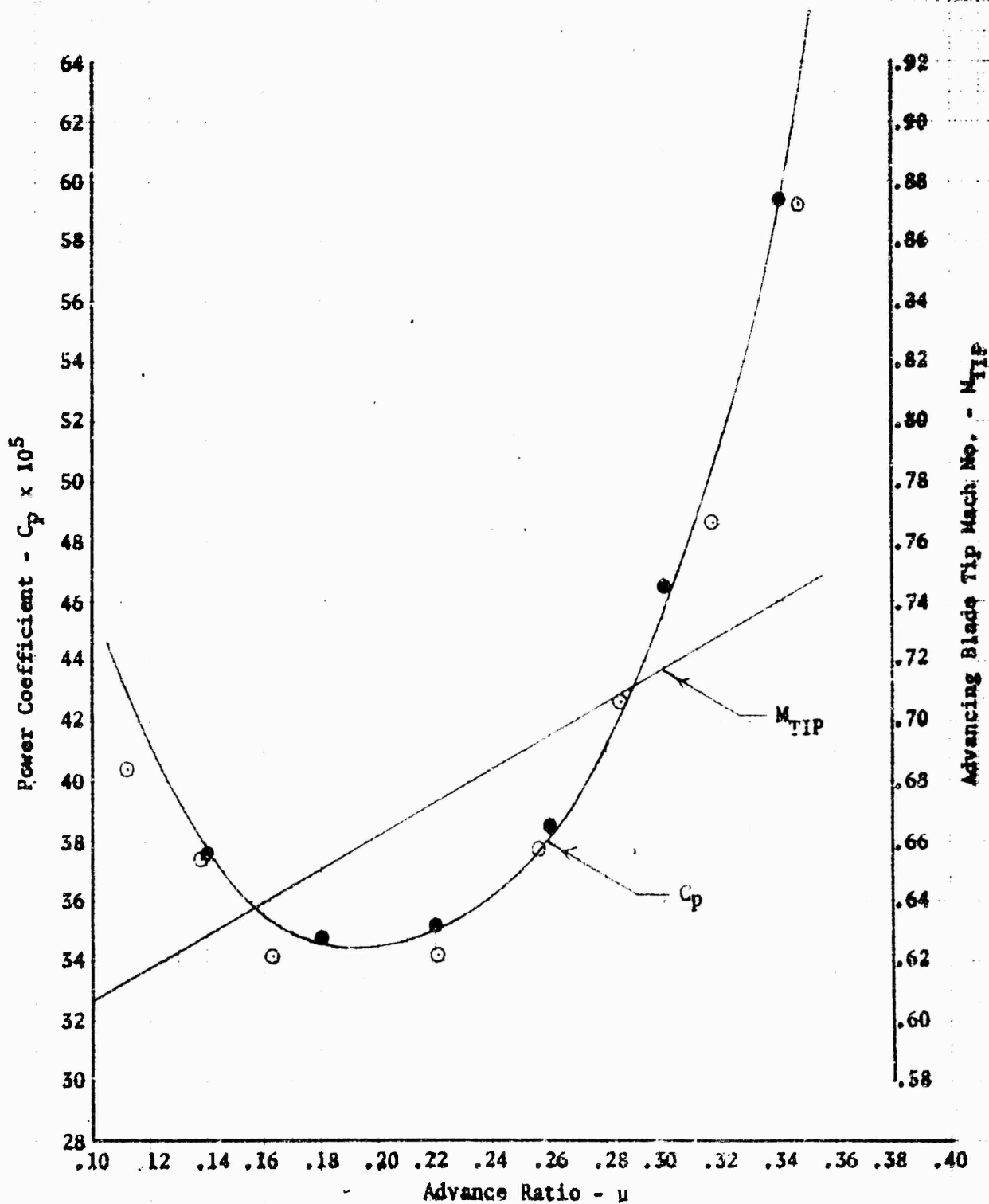

Figure 17. Level Flight Performance

CH-3E Helicopter

$CT = .00710$

- NOTES: 1. Open symbols and fairings denote flight test data as presented in reference 3.  
 2. Solid symbols are calculated data using  $C_p = C_{pic} + C_{pc} + C_{ps}$

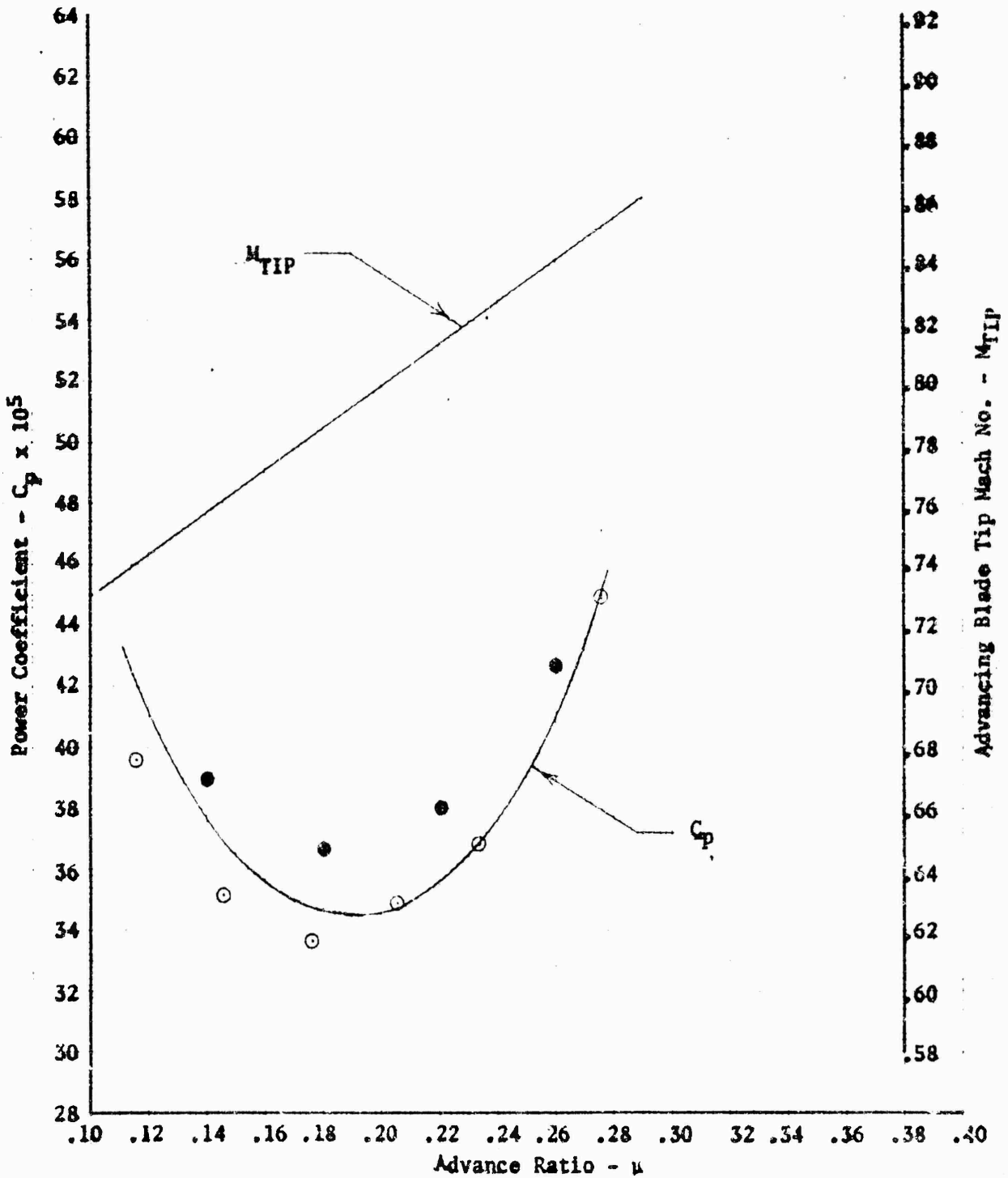

Figure 18. Level Flight Performance

OH-3E Helicopter

$C_T = .00768$

- NOTES: 1. Open symbols and fairings denote flight test data as presented in reference 3.  
 2. Solid symbols are calculated data using  $C_p = C_{pic} + C_{pc} + C_{ps}$

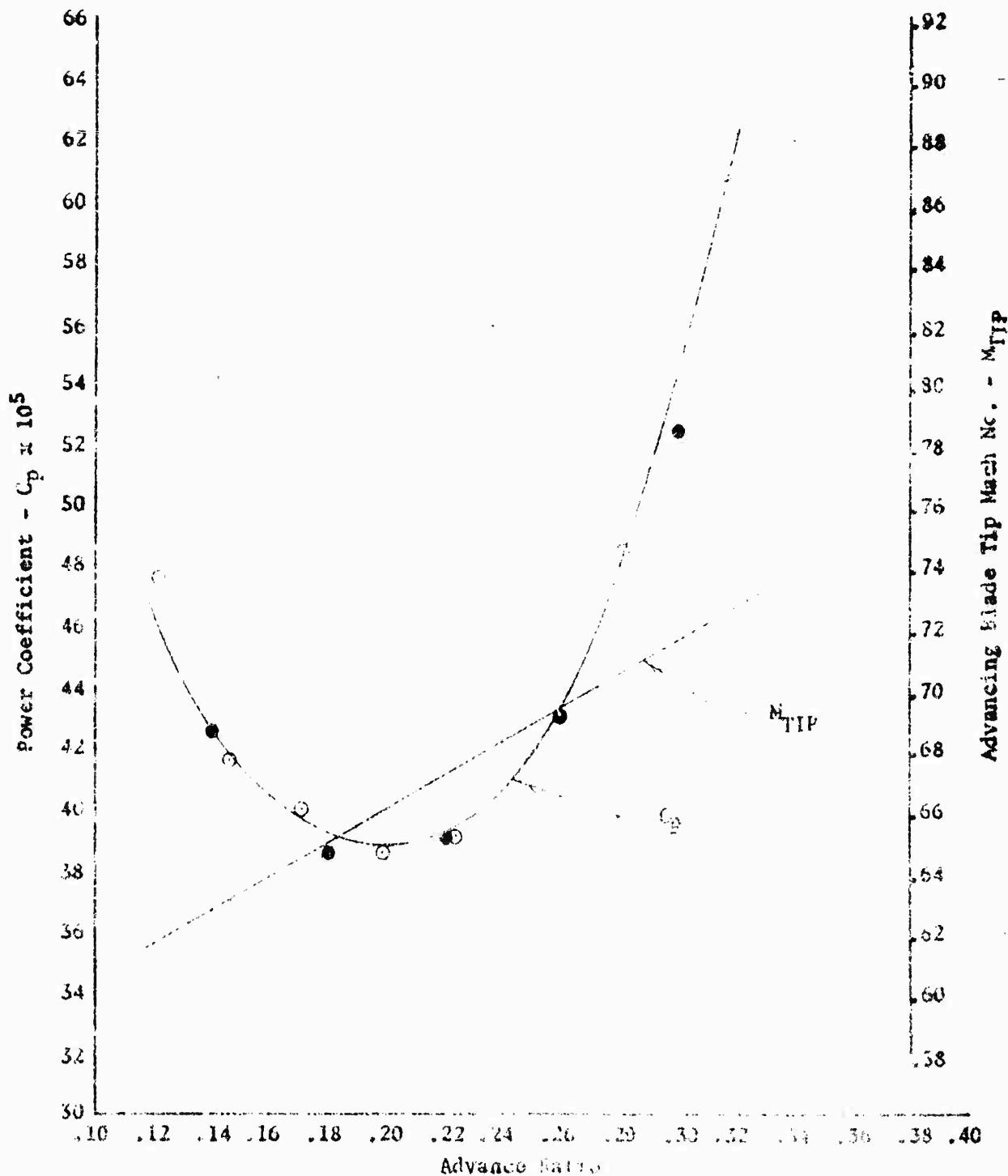

Figure 19. Level Flight Performance

CH-3E Helicopter

$C_T = .00766$

- NOTES: 1. Open symbols and fairings denote flight test data as presented in reference 3.  
 2. Solid symbols are calculated data using  $C_P = C_{Pic} + C_{Pc} + C_{Ps}$

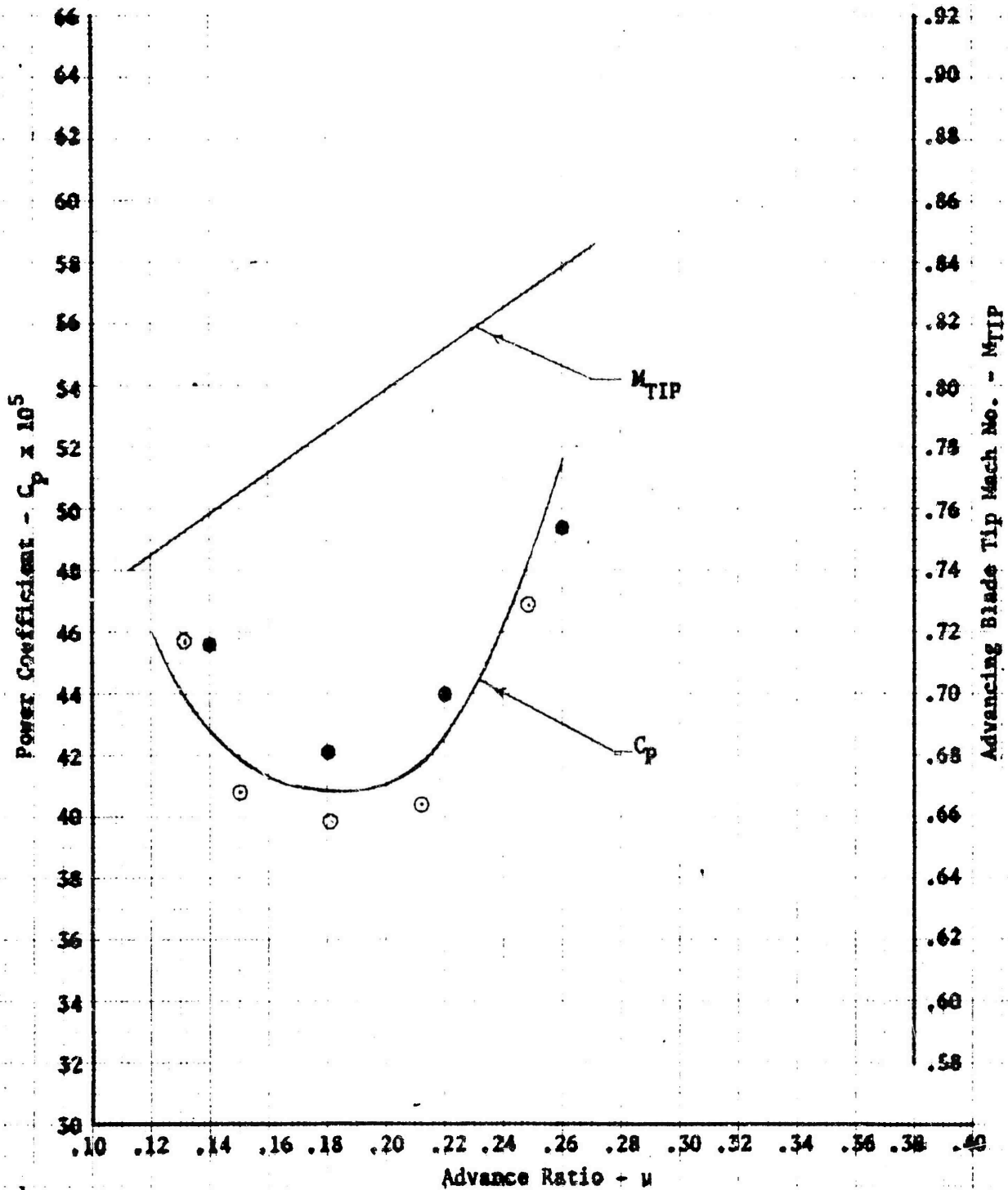

Figure 20. Level Flight Performance

CH-3E Helicopter

$C_T = .00846$

- NOTES: 1. Open symbols and fairings denote flight test data as presented in reference 3.  
 2. Solid symbols are calculated data using  $C_p = C_{pic} + C_{pe} + C_p$

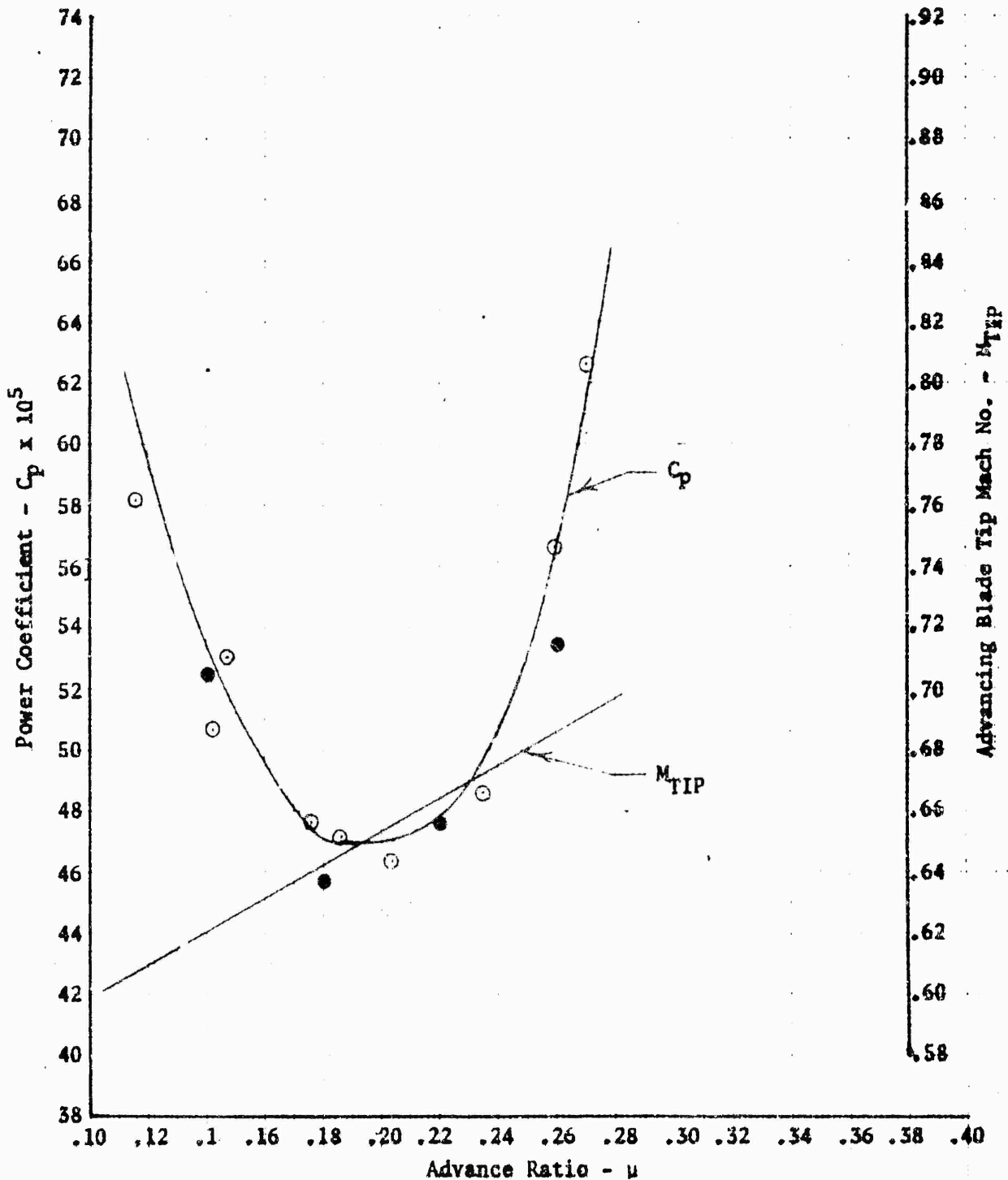

Figure 21. Level Flight Performance

CH-3E Helicopter

$$C_T = .00848$$

- NOTES: 1. Open symbols and fairings denote flight test data as presented in reference 3.  
 2. Solid symbols are calculated data using  $C_p = C_{pic} + C_{pc} + C_{ps}$

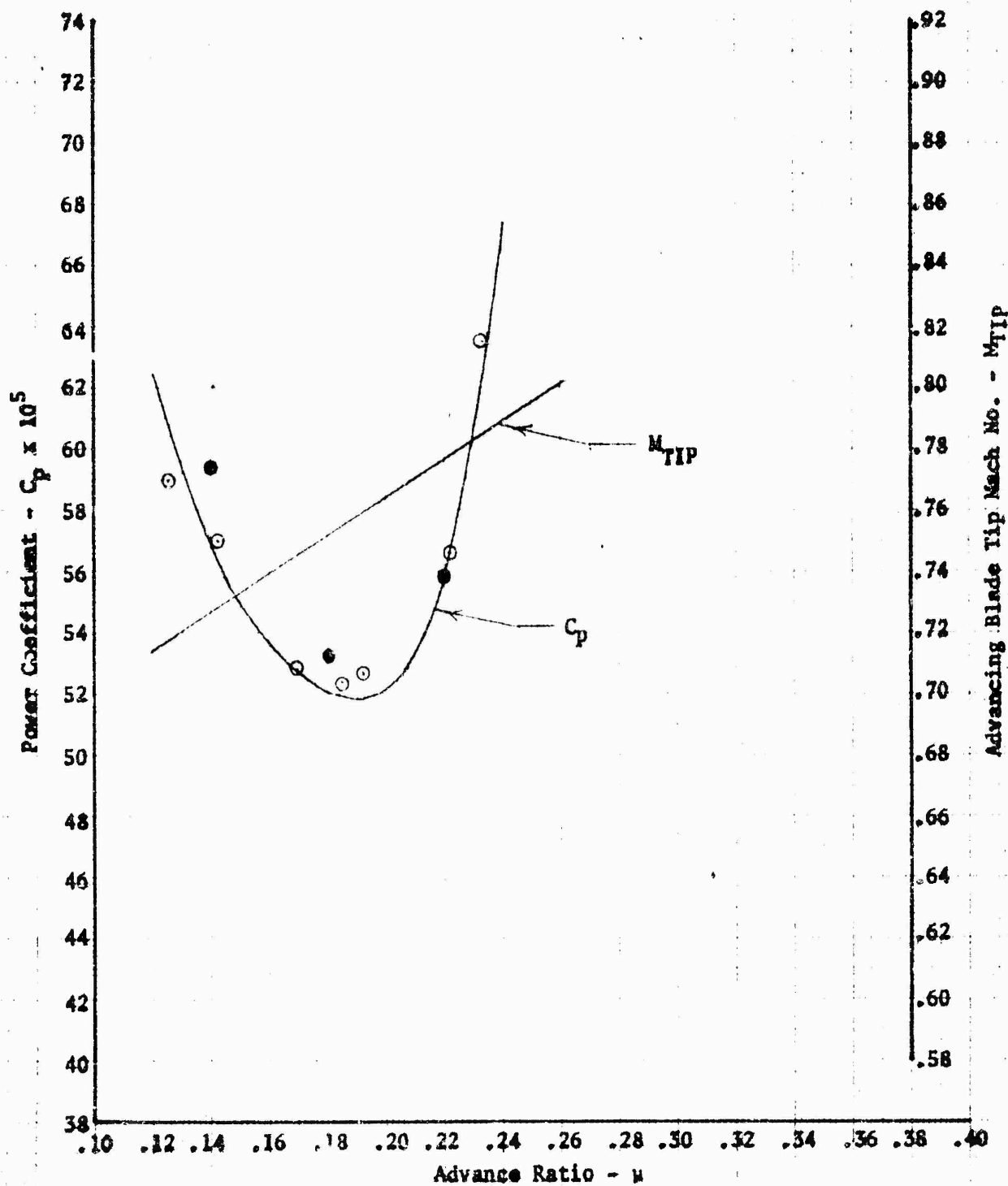

Figure 22. Level Flight Performance

## BIBLIOGRAPHY

1. Parks, Dr. E. K., An Analysis of Helicopter Rotor Blade Compressibility Effects, Flight Research Branch Office Memo, AFFTC, January, 1969. UNCLASSIFIED.
2. MacPherson, D. and Hodgson, W., Captain, USAF, YH-40 Performance Evaluation, AFFTC-TR-59-33, 1960. UNCLASSIFIED.
3. Barbini, W. and Heft, E., Captain, USAF, Determination of the Effects of Rotor Blade Compressibility on the Level Flight Performance of the CH-3C Helicopter, FTC-TR-67-10, 1967. UNCLASSIFIED.
4. Bramwell, Wilde and Johnson, Comparison of Theoretical and Experimental Determination of Helicopter Rotor Characteristics with Particular Reference to High Blade Incidence Conditions, - Royal Aircraft Establishment Technical Report No. 66139, 1966.
5. Carpenter, Paul J., Lift and Profile - Drag Characteristics of an NACA 0012 Airfoil Section as Derived from Measured Helicopter - Rotor Hovering Performance, NACA TN 4357, September 1958.

6. McCormick, B. W., Aerodynamics of V/STOL Flight, Academic Press, 1967.
  
7. Castles, W. and New, C., A Blade-Element Analysis for Lifting Rotors that is Applicable for Large Inflow and Blade Angles and Any Reasonable Blade Geometry, NACA TN 2656, July 1952.

DOCUMENT CONTROL DATA - R & D

(Security classification of title, body of abstract and indexing annotation must be entered when the overall report is classified)

1. ORIGINATING ACTIVITY (Corporate author) Air Force Flight Test Center Edwards Air Force Base, California		2a. REPORT SECURITY CLASSIFICATION Unclassified	
		2b. GROUP N/A	
3. REPORT TITLE Development of a Data Analysis Technique for Determining the Level Flight Performance of a Helicopter			
4. DESCRIPTIVE NOTES (Type of report and inclusive dates) Final			
5. AUTHOR(S) (First name, middle initial, last name) John R. Somsel			
6. REPORT DATE March 1970		7a. TOTAL NO. OF PAGES 60	7b. NO. OF REFS 7
8a. CONTRACT OR GRANT NO.		9a. ORIGINATOR'S REPORT NUMBER(S) FTC-TD-70-1	
b. PROJECT NO. N/A		9b. OTHER REPORT NO(S) (Any other numbers that may be assigned this report) N/A	
c.			
d.			
10. DISTRIBUTION STATEMENT This document has been approved for public release and resale; its distribution is unlimited.			
11. SUPPLEMENTARY NOTES N/A		12. SPONSORING MILITARY ACTIVITY 6512th Test Group Edwards AFB, California	
13. ABSTRACT This paper reviews and expands a helicopter level flight performance data analysis procedure that was formulated by Dr. E.K. Parks of the Aerospace and Mechanical Engineering Department, University of Arizona. The data analysis procedure presents formulae to account for rotor blade compressibility and stall effects which until recently have been largely ignored in classical rotor analyses. The initial approach for determining a helicopter's level flight power required was through a power buildup concept. This concept was modified during the report to be more compatible with the flight test environment. Flight test data of the CH-3C helicopter was used for comparing and verifying the analytic determinations. Reasonable approximations to the CH-3C flight test data was attained, although an improvement in accuracy is needed before the method can be substantiated as a valid flight test procedure. The analytic approach utilized was considered to possess the potential for arriving at a solution and further studies in this area are strongly recommended.			

UNCLASSIFIED

Security Classification

14. KEY WORDS	LINK A		LINK B		LINK C	
	ROLE	WT	RCLE	WT	ROLE	WT
helicopter flight testing level flight performance data analysis rotor blade compressibility stall effects						

UNCLASSIFIED

Security Classification

ACCESSION OF

WHITE SECTION

BLUE SECTION

UNAPPROVED

JUSTIFICATION

BY

DISTRIBUTION/AVAILABILITY CODES

SIST.	AVAIL. and/or	SPECIAL

When US Government drawings, specifications, or other data are used for any purpose other than a definitely related government procurement operation, the government thereby incurs no responsibility nor any obligation whatsoever; and the fact that the government may have formulated, furnished, or in any way supplied the said drawings, specifications, or other data is not to be regarded by implication or otherwise, as in any manner licensing the holder or any other person or corporation, or conveying any rights or permission to manufacture, use, or sell any patented invention that may in any way be related thereto.