

AROD-7875.1-RT

AD703936

NOTATION OF MOVEMENT

FINAL REPORT

GRANT

DA-ARO-D-31-124-G998

Sponsored by

U.S. ARMY RESEARCH OFFICE-DURHAM

15 February 1970

REC'D
ACR 26 1970
Library

DEPARTMENT OF ELECTRICAL ENGINEERING
UNIVERSITY OF ILLINOIS
URBANA, ILLINOIS
61801

Reproduced by the
CLEARINGHOUSE
for Federal Scientific & Technical
Information Springfield Va. 22151

This document has been approved for public
release and sale; its distribution is unlimited.
The findings in this report are not to be con-
sidered as an official Department of the Army
position, unless so designated by other au-
thorized documents.

3580

20090504 298

NOTATION OF MOVEMENT

FINAL REPORT

Covering the Period

1 March 1968 - 31 August 1969

GRANT

DA-ARO-D-31-124-G998

Sponsored by

U.S. ARMY RESEARCH OFFICE-DURHAM

Issued

15 February 1970

DEPARTMENT OF ELECTRICAL ENGINEERING
UNIVERSITY OF ILLINOIS
URBANA, ILLINOIS
61801

BLANK PAGE

PREFACE

Kraepelin (1) in his monumental attempt to develop a taxonomy of mental disorders was the first to use the notion of "sensorium" as the totality of the faculties of perception, orientation, memory, etc., as distinct from those of reasoning, volition, affectivity, etc. The conditions of the sensorium being clouded or else clear, other circumstances alike, allows for powerful diagnostic discrimination, hence provides an important conceptual tool to determine etiology and, ultimately, therapy of the disorder.

Complementary to this notion, the notion of "motorium" will be introduced here as the totality of the faculties of voluntary controlled movements from gait to speech to writing, etc., as distinct from those controlled by the Sympathicus, heart beat, peristalsis, papillary dilation, etc.

Phylogenetically, of course, sensorium and motorium evolve interdependently and synchronously, putting the question of primacy into the realm of disputes on the primacy of egg or chicken.

While many quarters still hold to the Cartesian notion that the so called "higher mental functions" emerge from the sensorium, it has become today abundantly clear that early impediments of the motorium afflict the sensorium as much as impediments of the sensorium leave their mark on the motorium. Epistemologically, even such abstract notions as "affirmative"

or "negative" (2), and as "true" or "false" (3), can be shown to be coupled to elementary movements respectively as approach or withdrawal, and as the proper or improper execution of a conditioned reflex. Consequently, the preoccupation with the study of the sensorium appears to have purely historical roots, and the maintained distinction between "sensory" and "muscle" physiologists is indeed not designed to foster an integrated vision of motorium and sensorium. Exceptions are, of course, Eccles' recent work on the cerebellum (4) and Green's elegant views on controlled and smoothed purposive movements (5).

Probably, the first to take qualitative studies of the motorium seriously were Noa Eshkol and Abraham Wachmann who, during the 1950's, developed a notation of movement (6) which was intended to prescribe by appropriate concatenations of symbols taken from a finite alphabet all movements that can conceivably be executed by the human body and, conversely, to describe any such movement by a corresponding string of symbols.

While it is obvious that any symbolism to be developed for this purpose will make use of the intrinsic constraints of bodily movements, it is, however, not obvious whether or not the symbols chosen for the alphabet as well as the chosen rules of concatenating symbols are necessary and sufficient to serve the task at hand. In other words, the question of completeness and consistency of a descriptive formalism for

bodily movements is by no means trivial, for nothing less is required than to show isomorphism between potential movements and the syntax of their symbolic representations.

On the other hand it is clear that such a system of notation would be of considerable value not only as a nucleus for a future theory of the neurophysiology, biomechanics and biology of organic movement, but also by its immediate applicability to the construction of anthropomorphic automata which are to perform in environments inaccessible or hostile to a human operator, and with which communication is maintained via channels of capacities orders of magnitude below those needed for continuous surveillance and without the benefits inherent in the redundancies of symbolic discourse.

At the time of the initiation of this project it was established that the alphabet earlier developed by Eshkol and Wachmann is indeed sufficient to satisfy the condition of completeness, however, the difficult task of showing consistency was not yet approached. Moreover, the formalism so far developed left on the syntactic level much to be desired.

To overcome these difficulties, the approach chosen in this study was to transcribe Eshkol-Wachmann notation into a computer program which would allow the machine to execute the movements by computing its trajectories, and deliver these either in numeric or graphic form. From this exercise the following results were anticipated:

1. A check of consistency of the underlying notation. Inconsistencies would immediately result in rejects of the program.

2. On the command side (input), the syntax of the programming language would provide the bridge between a command given in (somewhat restricted) natural language and in Eshkol-Wachmann notation.
3. On the execution side (output) it would provide a complete system of kinematic descriptions of movement, providing an invaluable formal skeleton for the study of dynamic and purposeful behavior.

The following report is a brief summary of the work performed under the auspices of this Grant, and it is believed that the desired results have been achieved. The notation has been found to be consistent; any command can be executed by the machine; and the initial steps of a mathematical foundation for a dynamic study have been made by extending the kinematic algorithm developed in this study. It is felt that the most excruciating and exhausting phases of any such attempt have been overcome and that the results presented herein will serve as a convenient basis for further rigorous quantitative and qualitative studies of man's dynamic potential.

The participants in this program acknowledge with gratitude the perpetual cooperation of the Departments of Electrical Engineering and of Computer Science, and particularly of the Department of Physical Education for Women, whose head, Dr. Alyse T. Cheska was an untiring source of encouragement and help.

I wish to express my thanks to Miss Janet Ficken, Mrs. Alexis Peterson and Miss Faith Puksza for their invaluable contributions in organizing and executing this report.

H.V.F.

REFERENCES

1. Kraepelin, E., Psychiatrie, 2nd edition, Abel, Leipzig (1887).
2. Von Foerster, H., "Thoughts and Notes on Cognition" in Cognition - A Multiple View, P. Garvin (ed.), Spartan Books, New York (in press).
3. Langer, S., Philosophy in a New Key, New American Library, New York (1951).
4. Eccles, J. C., M. Ito, and J. Szentagothai, The Cerebellum as a Neuronal Machine, Springer-Verlag, New York (1967).
5. Greene, P. H., "New Problems in Adaptive Control" in Computer and Information Sciences, J. T. Tou and R.H. Wilcox, Spartan Books, Washington, D. C. (1964).
6. Eshkol, N. and A. Wachmann, Movement Notation, Weidenfeld and Nicolson, London (1958).

PERSONNEL

Principal Investigator -

HEINZ VON FOERSTER
Professor, Departments of Biophysics
and of Electrical Engineering

Visiting Research Assistant Professor -

NOA ESHKOL
Professor, Israel Music Institute, Israel

Research Assistants -

PETER MELVIN
Department of Astronomy

JEAN MICHL
Department of Computer Science

Consultants -

ILANA BANAI
Movement Notation Society, Israel

HERBERT BRUN
Professor, Department of Music

JOHN HARRIES
Movement Notation Society, Israel

LAURA HUELSTER
Professor, Department of Physical Education

RACHEL NUL
Movement Notation Society, Israel

ABRAHAM WACHMANN
Professor, Israel Music Institute, Israel

SHMUEL ZEIDEL
Movement Notation Society, Israel

Clerical -

JANET FICKEN
Biological Computer Laboratory

ALEXIS PETERSON
Biological Computer Laboratory

TABLE OF CONTENTS

PREFACE.....	iii
PART A. THE PRINCIPLES OF MOVEMENT NOTATION.....	3
I. The Body and the Manuscript Page.....	8
II. The System of Reference.....	10
III. The Individual Systems and the General System of Reference.....	15
IV. Zero Position - Front.....	17
V. Positions.....	20
VI. The Notation of Movement: The Type of Movement.....	24
VII. The Notation of Movement: Spatial Definition and Sense of Movement.....	24
VIII. The Notation of Movement: Amount of Movement.....	36
IX. Simultaneous Movement.....	39
X. The Weight.....	41
XI. Contact.....	43
XII. Front.....	44
XIII. Conventions.....	46
PART B. MACHINE REPRESENTATIONS OF MOVEMENTS.....	53
I. Physiology of movement.....	54
II. Mathematical Abstraction of the Human Body.....	56
III. The E-W Program: DANCER.....	62

	Page
IV. A Model of the Human Body: STKMAN.....	84
V. Conclusion.....	94
References.....	98
Appendices.....	99

PAR. A

THE PRINCIPLES OF MOVEMENT NOTATION

(Eshkol and Wachmann)

BLANK PAGE

THE PRINCIPLES OF MOVEMENT NOTATION

The progress of human thought and activity in various fields in science and in art without the development of appropriate notations is unimaginable. As in other spheres, movement of the human body requires a concise and simple system of symbols which will make possible composition and description of events in this field; such a system should constitute a tool of communication by means of which three aims are attainable:

- 1) The recording of movement.
- 2) The possibility of analysis of, and composition in, the material (movement).
- 3) The creation of common concepts among the workers in the field under discussion, making possible clarification and definition, tuition and criticism.

By trying to imagine the development of the world of music without a musical notation, we may obtain an idea of what the notation could contribute to the world of movement in all its various branches.

In order that the notation system may be efficient and valid, and capable of developing the treatment of the world of movement without arriving at internal contradictions, it must be founded on a basic analysis (without a priori conventions) of all the components of the movement of human body that can be perceived.

If the notation is to constitute a symbolic system presenting the components of the material and the relations between them in the most exact manner, it must be so constructed that the manipulations possible within it do not fall short of the manipulations possible in the material itself. In other words, the test of the notation lies in its making possible the expression (in principle, and without going into detail) of the maximum of movement possibilities of the human body. Only then does there exist the probability that every movement open to perception will be expressible in the notation.

The more fundamental the component, the more simple and efficient must be its expression in the notation. When entering upon greater detail, and aspects of secondary importance, greater freedom in the introduction of conventions becomes permissible.

In the movement notation, the following aspects are given symbolic expression:

- 1) The human body.
 - 2) The movements of the parts of the body.
 - 3) Movement space (system of reference - sense of movement - observer).
 - 4) Quantitative data (amount of movement, duration).
 - 5) Conventions.
- 1) The Human Body. For the purposes of the notation we regard the human body as a system of straight "rods" (limbs)

connected to one another by joints. Movement of the whole body is therefore the sum of the movements of the separate limbs, just as a particular state of rest of the whole body is the aggregate of the positions of the separate limbs.

2) The Movement of the Parts of the Body. In analysing the movement of the body, we shall begin with the analysis of the movement of a single limb. Each limb moves about the joint to which it is connected. In this movement (assuming that the limb possesses complete freedom of movement about the joint) three elements are discernible:

- a) The centre of movement (the joint).
- b) The axis of the limb.
- c) The axis of movement.

If the joint is considered as a centre of movement fixed in space, then clearly every movement of the limb about it is in fact "spherical" (takes place within a sphere).

In the whole of "spherical" movement, three "types" may be distinguished (different groups of relations between the axis of the limb and the axis of movement):

Rotatory movement, in which the limb moves about its own axis without changing its place in space. The axis of the limb and the axis of movement coincide. (The extremity of the limb remains fixed at one point on the surface of the sphere.)

Plane movement, in which the limb moves in a plane. The axis of the limb is at right angles to the axis of

movement. (The extremity of the limb describes the "great circle" on the surface of a sphere.)

Conical movement, in which the limb moves in a cone. The axis of the limb is at an acute angle to the axis of movement. (The extremity of the limb moves in a circle which is smaller than the "great circle".)

3) Movement Space. For the description both of positions and of movements, a system of spatial reference is required to which can be related the place of the limb, its change of place (movement) and the sense (direction) of movement. Since the system of movement of the body is a system of spheres, i.e., rods moving about joints, the system of reference chosen is a system of spherical coordinates to which is related in parallel fashion the "movement sphere" of each separate limb.

The relation to this system of reference, positions may be established and indicated by giving to each limb the symbols for the spatial coordinates appropriate to its position. However, movement may be described in three ways:

- 1) By expressing the movement as a transition from one defined position to another defined position (indicating the character of the path, sense, amount of movement, and duration).
- 2) By establishing the positions of the axis of the limb and the axis of movement (plus sense, amount and duration).
- 3) By reducing the path of the movement to two projections: the projection on the horizontal plane,

and the projection on a vertical plane. The simultaneous description of these two projections defines the path of the movement (plus sense, amount and duration).

Every movement of a limb in a particular path can be executed in one of two contrary directions: "clockwise" or "anti-clockwise" (positive or negative). It is essential to establish which is to be the "positive" and which the "negative" sense in the different types of movement.

4) Quantitative Data. Having defined type and path of movement, and sense, two further quantitative data are still required for the full writing of movement: "amount of movement" and "duration of movement".

It is necessary to indicate the size of the sector of movement performed by the limb in the given path. Since we are concerned with circular paths, the movement sector can be measured as a fraction or as a multiple of a circle.

The duration of each movement must be indicated on the manuscript page. It is expressed as a multiple of a time unit, the value of which is established for each particular piece of notated work, taking into consideration the structure of its time pattern.

5) Conventional Signs. In addition to the basic factors of movement, there are certain physical phenomena without the description of which movement cannot be accurately expressed. In such cases, and in cases where a movement recurs with

great frequency, it is possible and desirable, for reasons of simplicity, to employ special symbols and abbreviations. A list of these signs and abbreviations is given on pages 46-49.

I. THE BODY AND THE MANUSCRIPT PAGE

Figure 2 shows the division of the body into independently moving parts. To each of these limbs a space is allocated on the manuscript page (Figure 1). For certain styles of movement, the body may be understood as comprised of more moving limbs than are provided for here (by the addition of fingers, for example). In such cases, the required number of spaces is added to the manuscript page. On the other hand, in the case of movement confined to a smaller number of limbs the page need include only the spaces necessary, as is done in a musical score.

Figure 2 shows the division of the manuscript page: each of the upper 18 horizontal spaces is allocated to a different limb. The bottom space is allocated to the notation of the "front" (see illustrations on page 21). The second space from the bottom is allocated to the notation of the weight and changes of weight (see illustrations on page 42).

The division of the page into equal vertical columns serves for the notation of the duration of the movements, each column representing a time unit whose absolute value is given at the beginning of the work (like the metronome indication in music). For example: $TU = 78$.

II. THE SYSTEM OF REFERENCE

When a limb moves about a "fixed" joint, the "surface" or "paths" produced by its movement are confined within an imaginary sphere. The extremity of the limb moves on the surface of the sphere. (See Figure 3.)

A system of reference appropriate to the analysis of positions or movements of a limb moving "within a sphere", is a spherical system. The definition and measurement of positions and movements within such a system are made possible by the spatial division of the sphere by means of two complementary systems (see Figure 4),

- a) the network of the coordinates on the surface of the sphere (see Figure 5), and
- b) the dispersion of the "positions", i.e., the lines connecting the centre of the sphere and the points of the network of coordinates (see Figure 6).

The network of coordinates dividing the surface of the sphere is constructed (like the geographical globe) from an intersecting net of "lines of longitude" (vertical circles) and "lines of latitude" (horizontal circles), the intersections of which are the points of the coordinate network. The axis connecting the upper and lower poles always remains in the vertical position, and is called "the vertical axis of the system of reference". The "equatorial plane" always remains in the horizontal position, and is called "the horizontal plane of the system of reference".

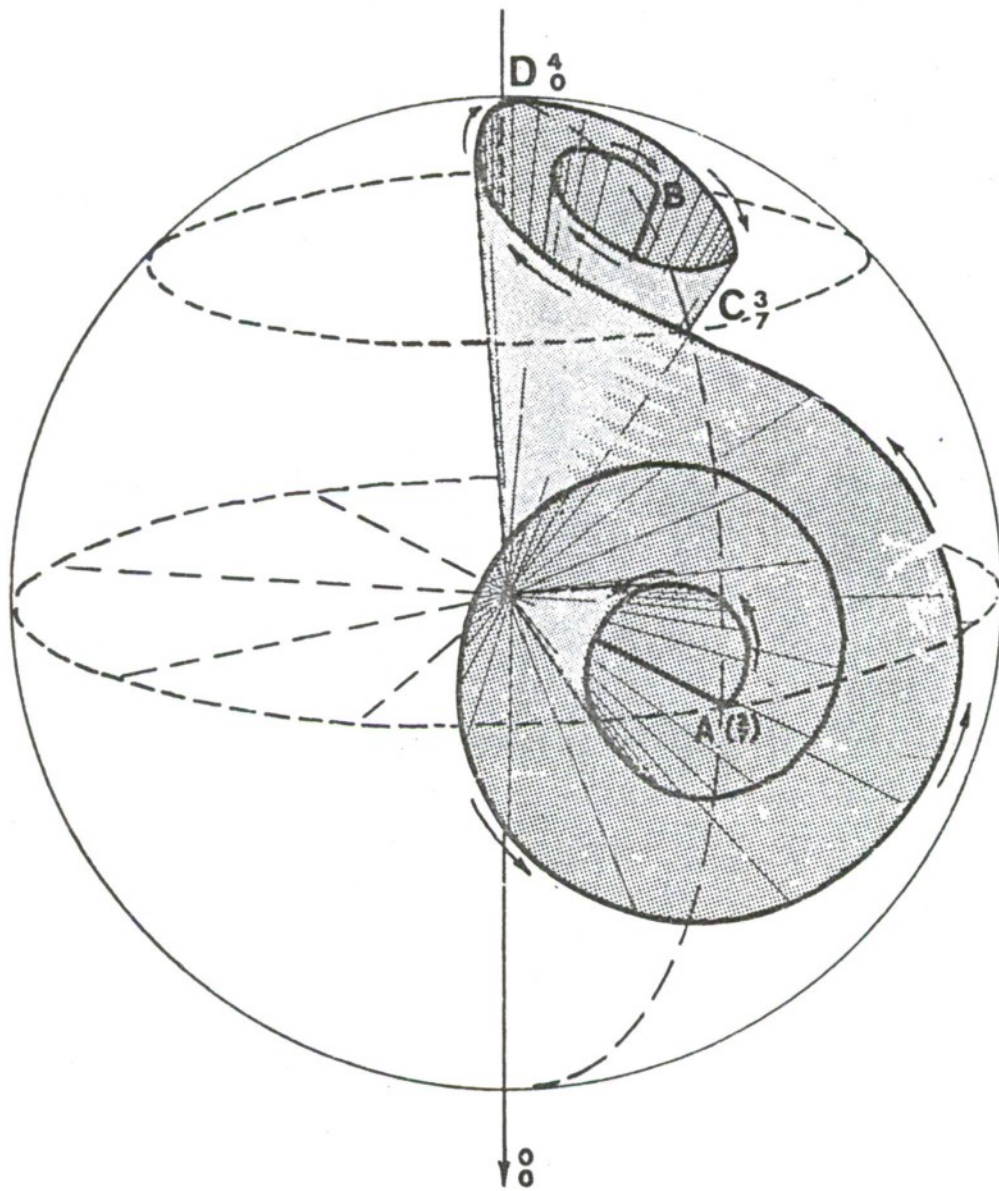

Figure 3.

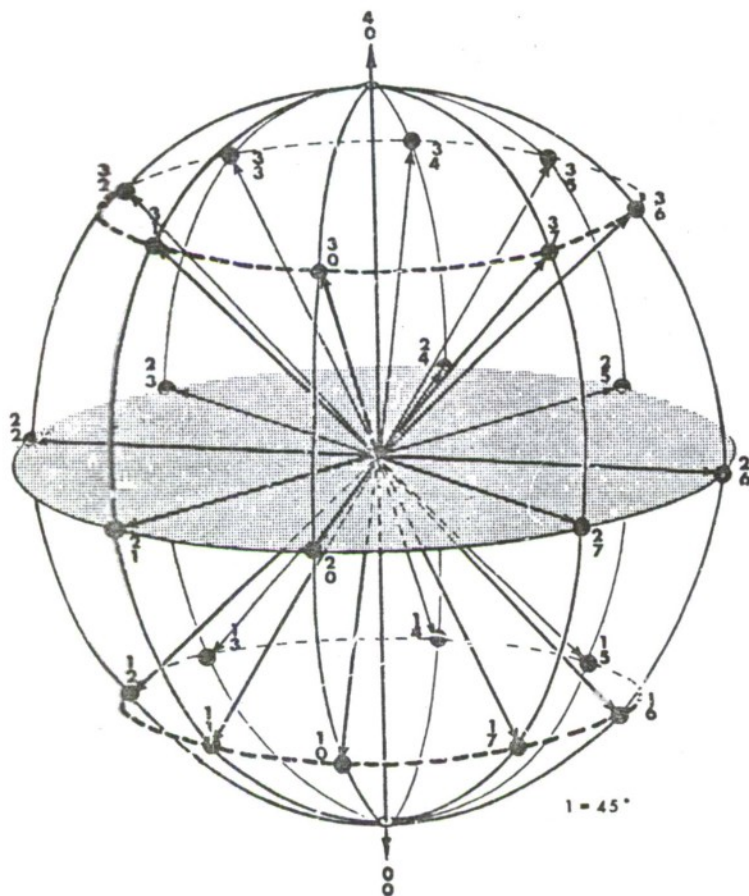

Figure 4.

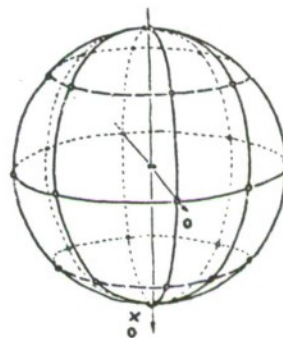

Figure 5.

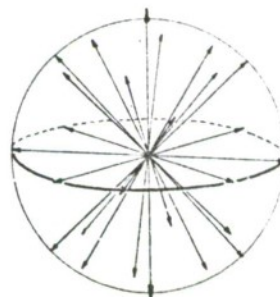

Figure 6.

By the term unit of measure of the system of reference we refer to the distance between two adjacent points of the network or between two corresponding positions (see Figure 7); an angular unit (arc or sector), measured in degrees of a circle. In this section we deal with a division in which the lines of longitude and of latitude are both divided by the same unit, so that the angular distance between any two adjacent points of the network is equal in the vertical and the horizontal directions. The unit of measure may, however, be of different size, according to need. Figures 8, 9, and 10 show a schematic skeleton of the system of reference, with a different unit of measure in each case. In Figure 8 the unit of measure is 90° , in Figure 9, 45° and in Figure 10, 30° .

The number of lines of longitude and latitude will change correspondingly to the size of the unit of measure, and also, as a direct result of this, the number of positions. The size of the unit of measure determines the quantitative scale of the system of reference, and at the beginning of each manuscript, the equivalent is given (in degrees) of one unit of measure in the chosen scale. Every line of longitude is indicated by a number. If we establish one of the directions on the horizontal plane as "horizontal zero", then the number expressing any given line of longitude will indicate by how many units of measure it deviated, horizontally, from direction 0.

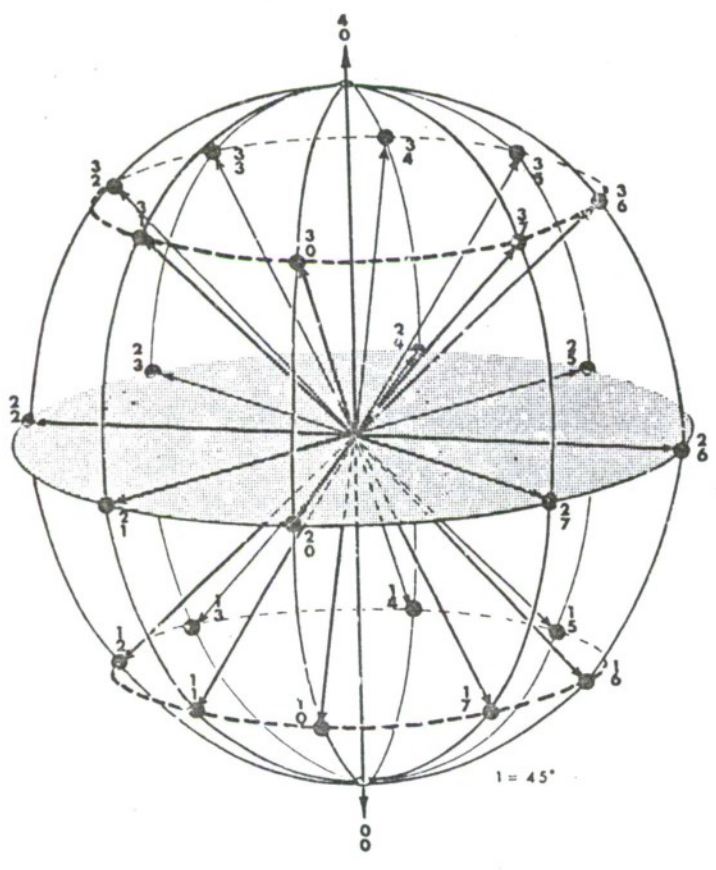

Figure 7.

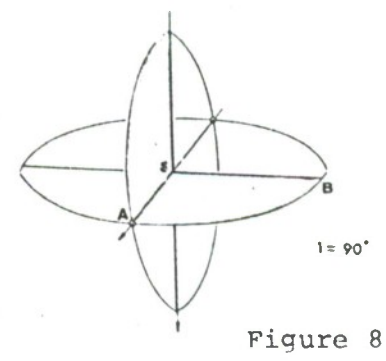

Figure 8.

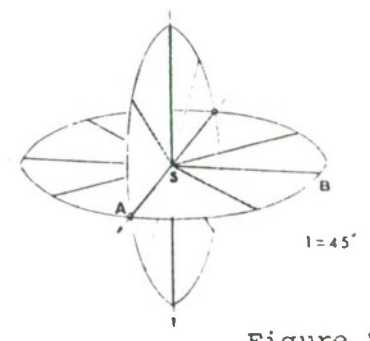

Figure 9.

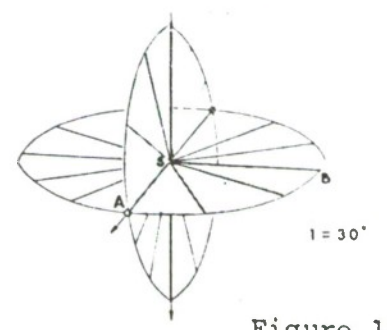

Figure 10.

Every position of the coordinate network may be expressed by two numbers. One number indicates on which line of longitude it is located (the "horizontal component"). The other number indicates its place on the said line of longitude (its latitude); that is--by how much the said point deviates vertically from the lower pole (point 0).

For the expression of a network-point or position, two numbers are necessary, placed one above the other and enclosed in brackets, for example, $\left(\begin{smallmatrix} 3 \\ 2 \end{smallmatrix}\right)$. The lower number represents the horizontal component, and the upper the vertical component.

In Figure 11 a number of movement sectors are enclosed within the system of reference, 1) a horizontal plane movement sector between positions A and B, 2) a vertical plane movement sector between positions E and F, 3) an intermediate plane movement between positions C and D, and 4) a conical movement between positions G and H. (An exact definition and explanation of the above types of movement is given later.)

III. THE INDIVIDUAL SYSTEMS

AND THE GENERAL SYSTEM OF REFERENCE

The construction of the system of reference has so far been related to a single limb. Movement of the whole body is the aggregate of the movements of the various limbs. The analysis of movement of the whole body is thus the analysis of the movement of each separate limb in relation to its own

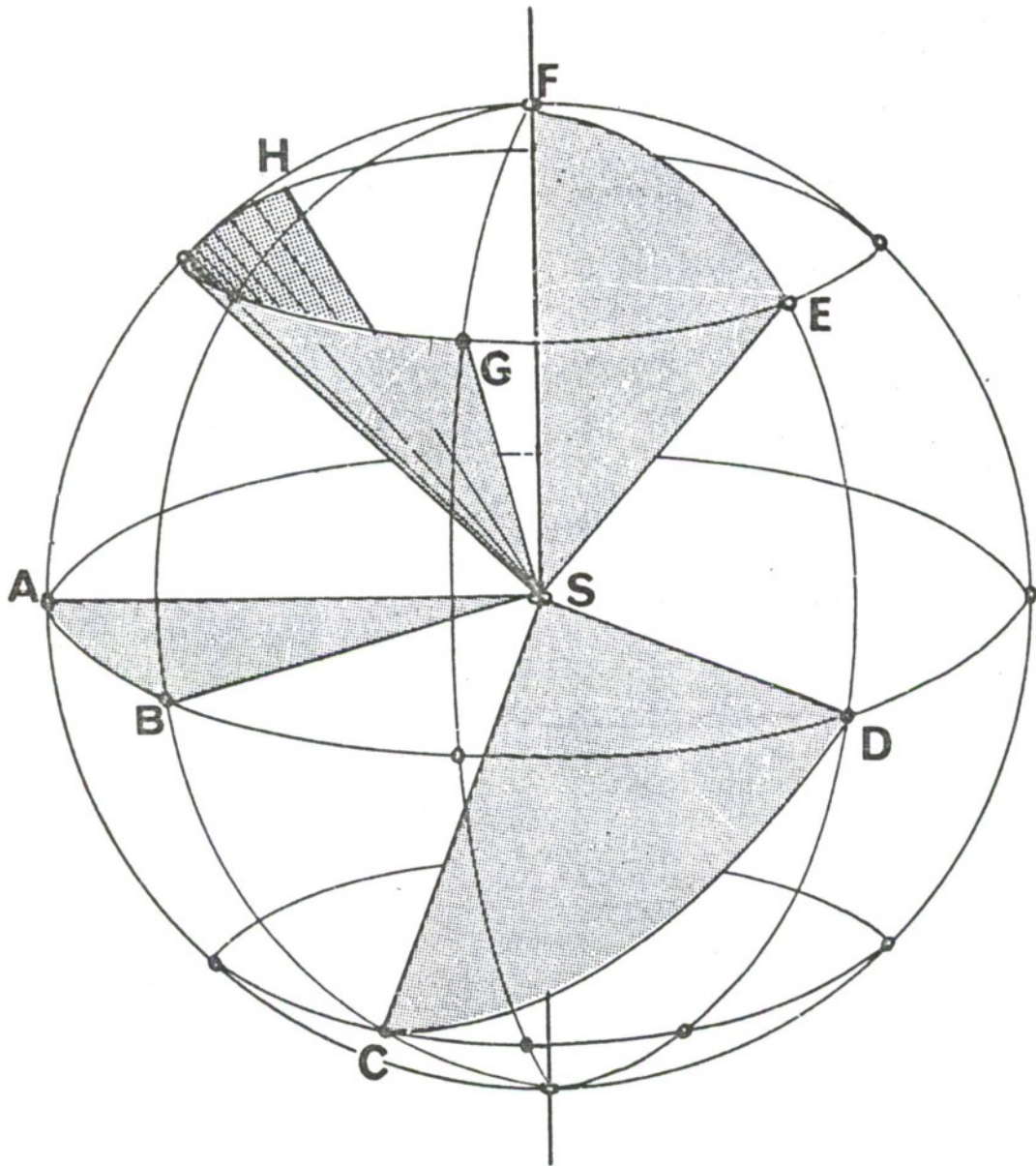

Figure 11.

"individual" spherical system of reference, the centre of which coincides with the joint about which that limb moves. Since the individual systems of reference are in parallel relation to each other, instead of speaking of a cluster of parallel spherical systems, we may speak of a single imaginary spherical system: the System of Reference. Figure 12 demonstrates this parallelism. In Figure 13 the individual system of reference attached to a particular limb (in this case, the forearm) is carried with it, in its movement. In Figure 14 a section of horizontal movement of the arm (with A' - B' included in its individual sphere and A - B the same movement reflected in a second system) is shown.

IV. ZERO POSITION - FRONT

In the writing both of movement and of positions, we take into consideration the longitudinal axis of the limb. To determine the position of a particular limb means determining the place of its longitudinal axis; and the analysis of its movement means the analysis of the movement of its axis (see Figure 15). The position of the body in normal upright posture, with feet parallel, is referred to as zero position. The figure brings out the fact that in zero position most of the limbs are in a vertical position. When a limb is in zero position, this is indicated by the sign (0) in the appropriate space.

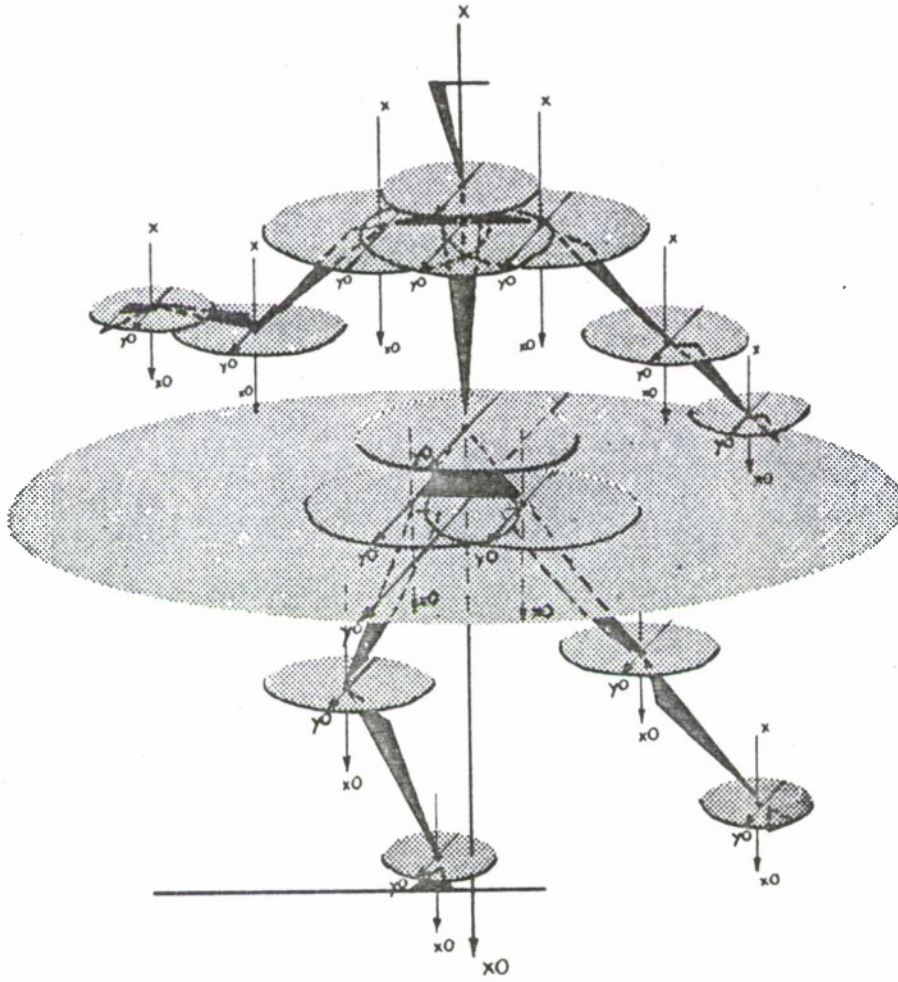

Figure 12.

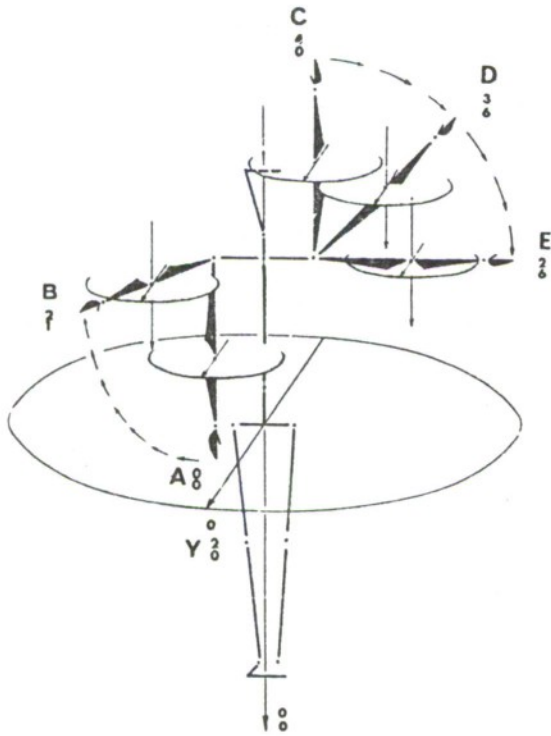

Figure 13.

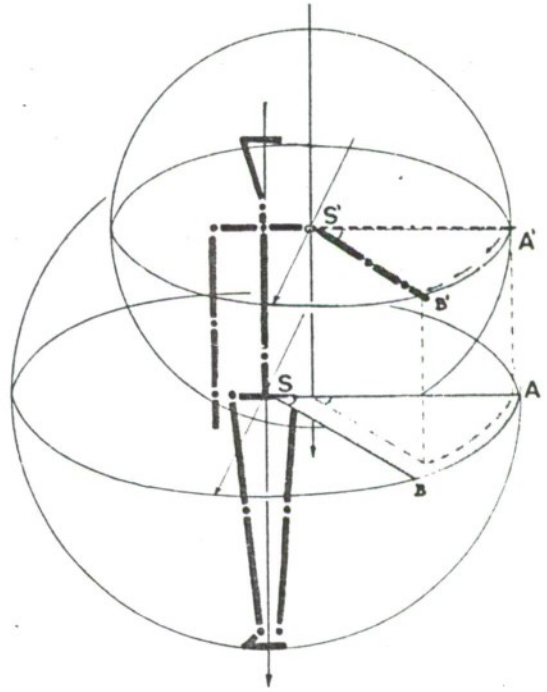

Figure 14.

In zero position the "forward" surfaces of all the limbs of the body face in the direction (0) on the horizontal plane, and both together face the observer; this state is expressed by the sign 0 in the lowest space of the page--the space allocated to the "front" (see Figure 16).

V. POSITIONS

The position of the body at a particular moment is the sum of the positions of all its parts at that moment. In order to notate a position of the whole body, these simultaneous states must be expressed. One example of such notation was that of "zero position", which was first defined, and then given a conventional sign. In all other cases, however, it is necessary to define the position of each limb in space. In analysing and writing the position of a limb, we relate it to that position in the system of reference which is parallel to the axis of the limb. In Figure 17, the diagram is given again here, to show the positions and their symbols, as defined in a system of reference with the scale of 45°. Figure 18 shows the definition of positions of the forearm. Each position is defined by two numbers in brackets; the lower indicates the horizontal coordinate, and the upper, the vertical coordinate. The position of the whole body is represented in a vertical column, the position of each limb being written in the appropriate space in Figure 19.



Figure 15.

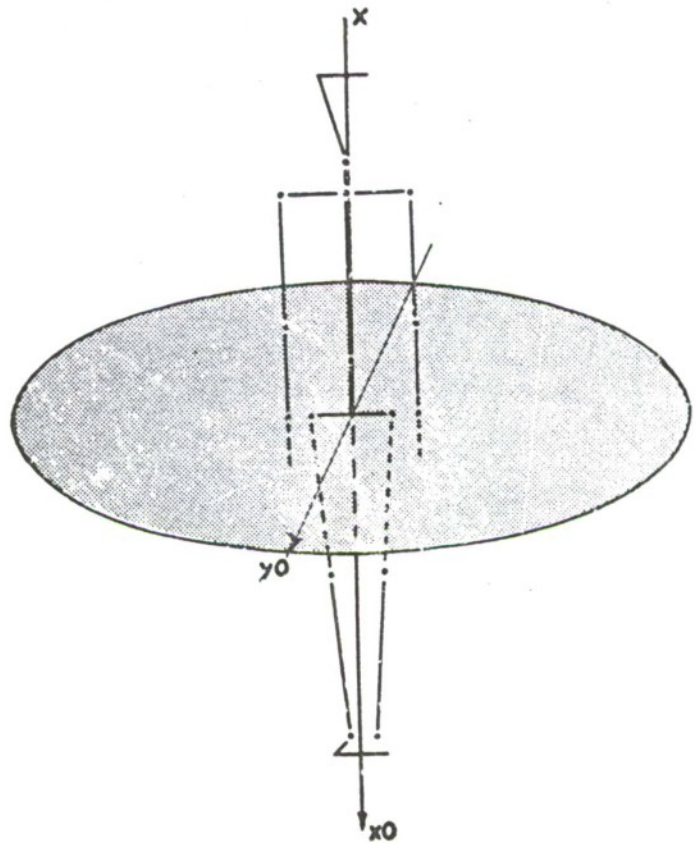

Figure 16.

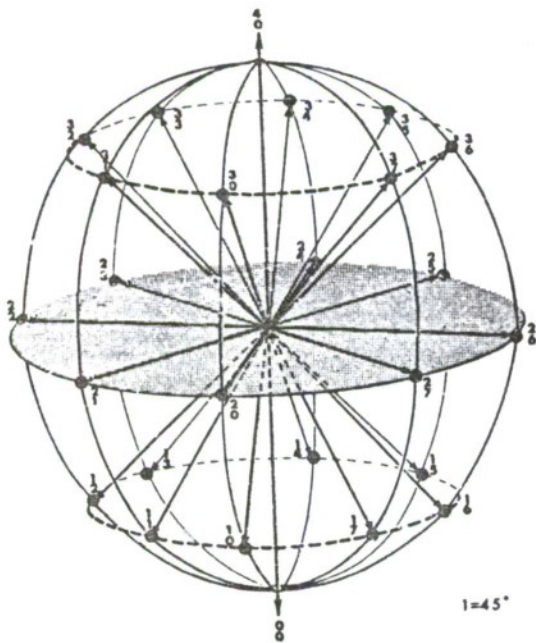

Figure 17.

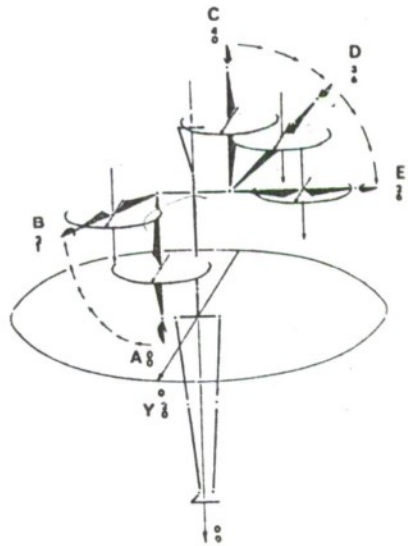

Figure 18.

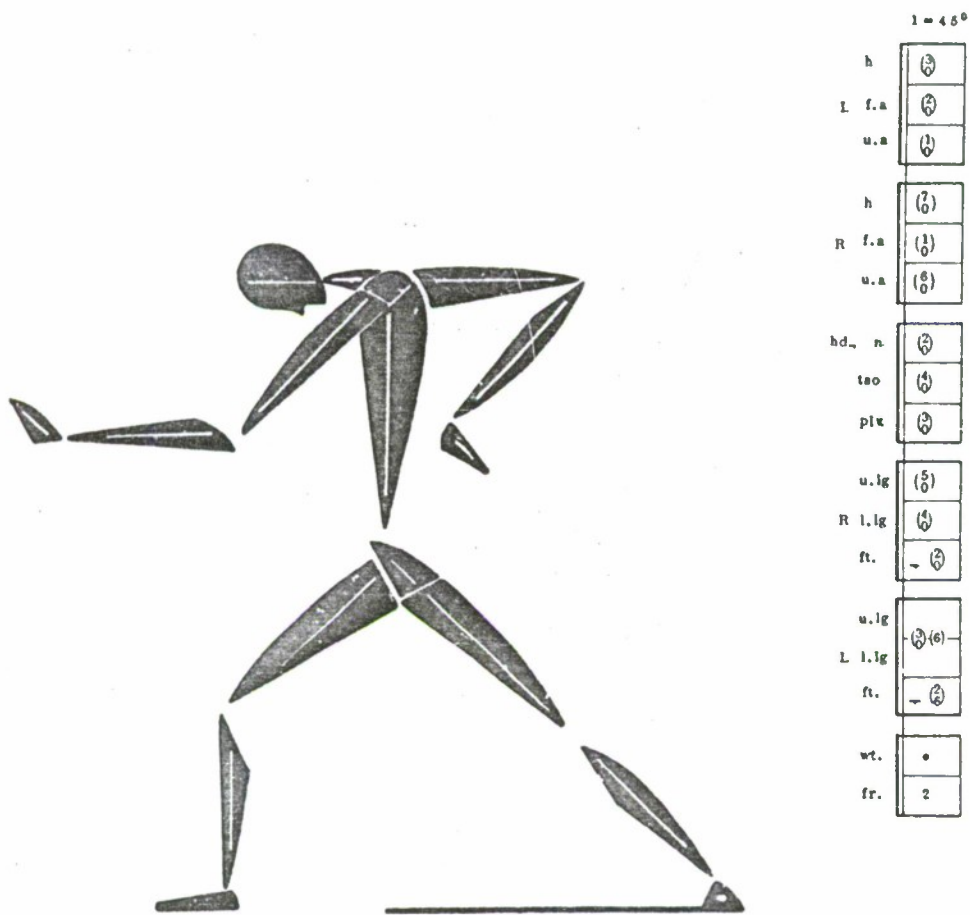

Figure 19.

VI. THE NOTATION OF MOVEMENT: THE TYPES OF MOVEMENT

One type of movement is rotatory movement with angle of movement zero. (The term "angle of movement" is given to the angle obtaining between the axis of the limb and the axis of movement through the movement.) The axis of the limb and the axis of movement coincide as shown in Figure 20. Rotatory movement in various limbs is apparent in Figure 21.

A second type of movement is conical movement, with angle of movement less than 90° . The axis of the moving limb produces a conical envelope, or part of such an envelope (see Figure 22). Shown in Figure 23 are conical envelopes produced by the movements of the arm and of the leg. The two cones produced by the arms have different angles of movement.

A third movement is plane movement which has an angle of movement of 90° . In Figure 24 the movement of the axis of the limb produces a plane; and in Figure 25, plane movement in the arm and the leg is pictured.

VII. THE NOTATION OF MOVEMENT:

SPATIAL DEFINITION AND SENSE OF MOVEMENT

7.1 Rotatory Movement.

In rotatory movement the sense ("direction") of movement is determined in relation to zero position (Figure 26). In zero position almost all the limbs are in a vertical position,

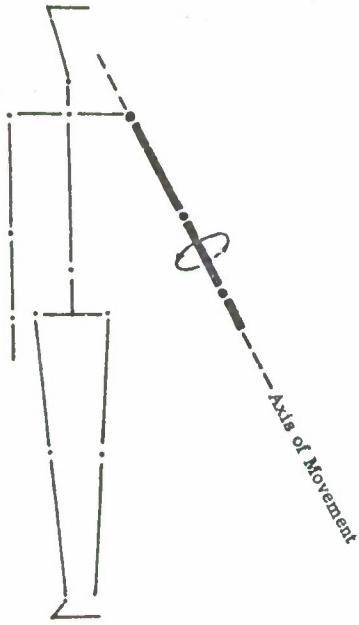

Figure 20.

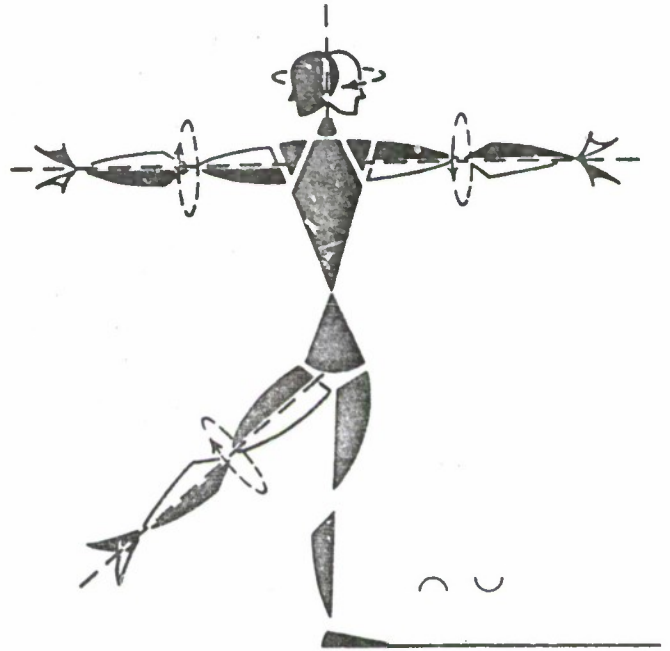

Figure 21.

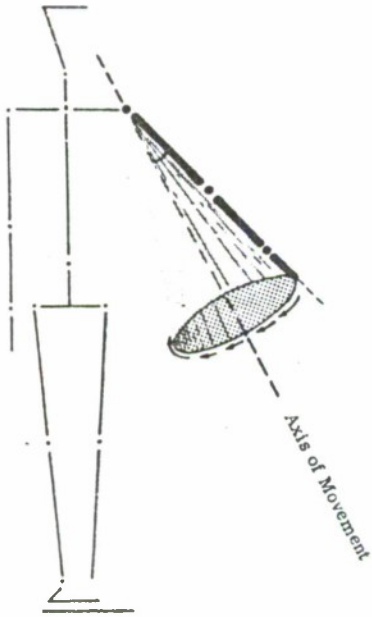

Figure 22.

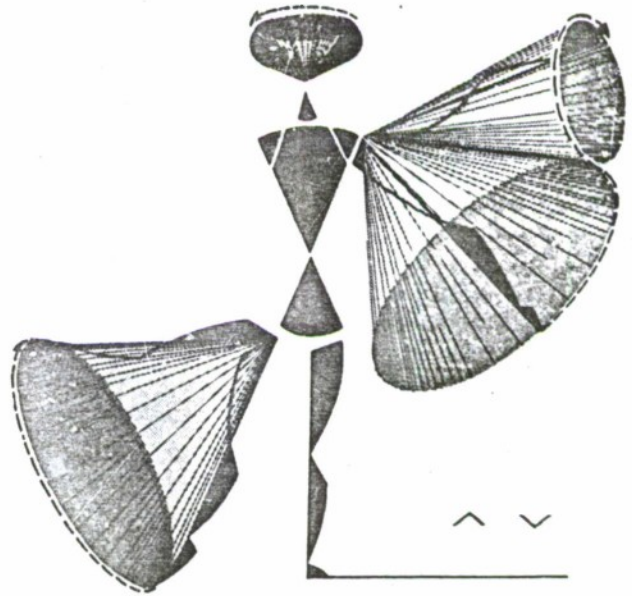

Figure 23.

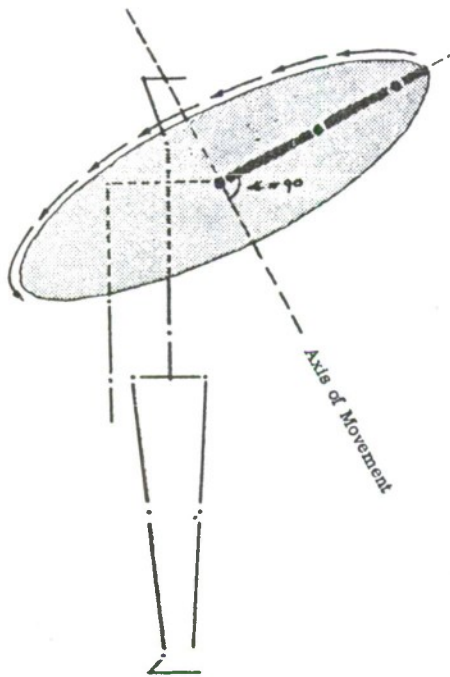

Figure 24.



Figure 25.

and rotatory movement in that position is performed about the vertical axis; any rotation in a clockwise direction, as seen from above, is in the positive sense; rotation in the anti-clockwise direction is in the negative sense. These senses of rotatory movement remain "attached" to the limbs, even when the latter change their location in space (Figure 27). The arrows in the figure show the direction of rotatory movement in the positive sense. The sign for positive rotatory movement is \curvearrowright . The sign for negative rotatory movement is \curvearrowleft .

[Note: The "rotatory state" of the limb is indicated by allotting to the four sides of the limb (left, right, front, and back) the appropriate numbers, derived from a system of reference of scale $1 = 45^\circ$. These numbers remain attached to the sides of the limb, like "labels". (Note that, even in bilaterally symmetrical limbs, this labelling is not bilateral.) It is then possible to indicate at any moment which side of the limb faces upward, excepting in positions $\begin{pmatrix} 0 \\ 0 \end{pmatrix}$ and $\begin{pmatrix} 4 \\ 0 \end{pmatrix}$, in which cases the side facing direction (0) is indicated.]

7.2 Conical Movement.

The size and location of a cone produced by a moving limb are defined with the aid of the positions of the ends of the diameter of the base of the cone. As the position of the limb at the beginning of the movement may be taken as one of the ends of the diameter, only the position of the other end

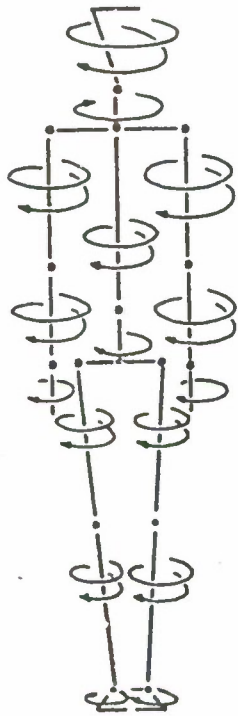

Figure 26.

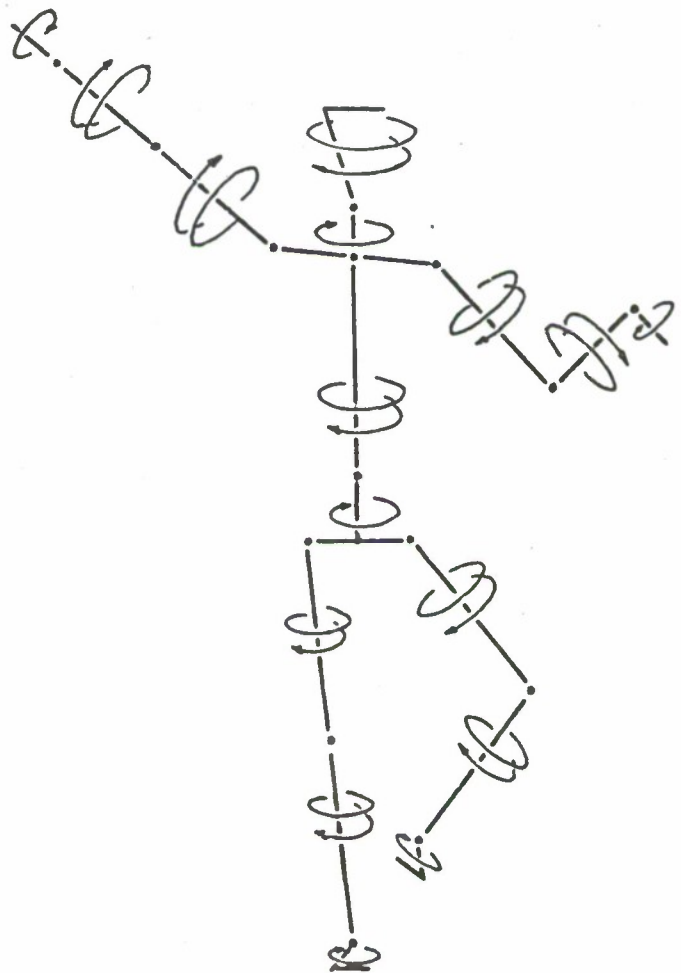

Figure 27

need be indicated. (See Figure 28.) In conical movement the sense of movement is determined by looking from the apex of the cone towards the base: the movement then seen as clockwise is positive, and that seen as anti-clockwise is negative. In Figure 28, the movements in the left-hand and upper cones, in the direction indicated by the arrows, are in negative sense; that in the right-hand cone, in the direction of the arrows, is positive. The sign for positive conical movement is \wedge . The sign for negative conical movement is \vee .

7.3 Horizontal Plane Movement.

Horizontal plane movement is movement in which the limb is in a position parallel to the ground at the beginning of the movement and moves on the horizontal plane. (See Figures 27-30.) The sense of movement in horizontal plane movement is established by looking down on the plane from above:

Positive movement - clockwise: \rightarrow

Negative movement - anticlockwise: \leftarrow

In Figure 30, the horizontal plane movement from A to B is positive and from B to A negative.

7.4 Vertical Plane Movement.

Vertical plane movement is movement in which the axis of the limb moves in a vertical plane. (See Figure 31.) A limb may move in a vertical plane movement from any position in the system of reference. In such movement, the positive

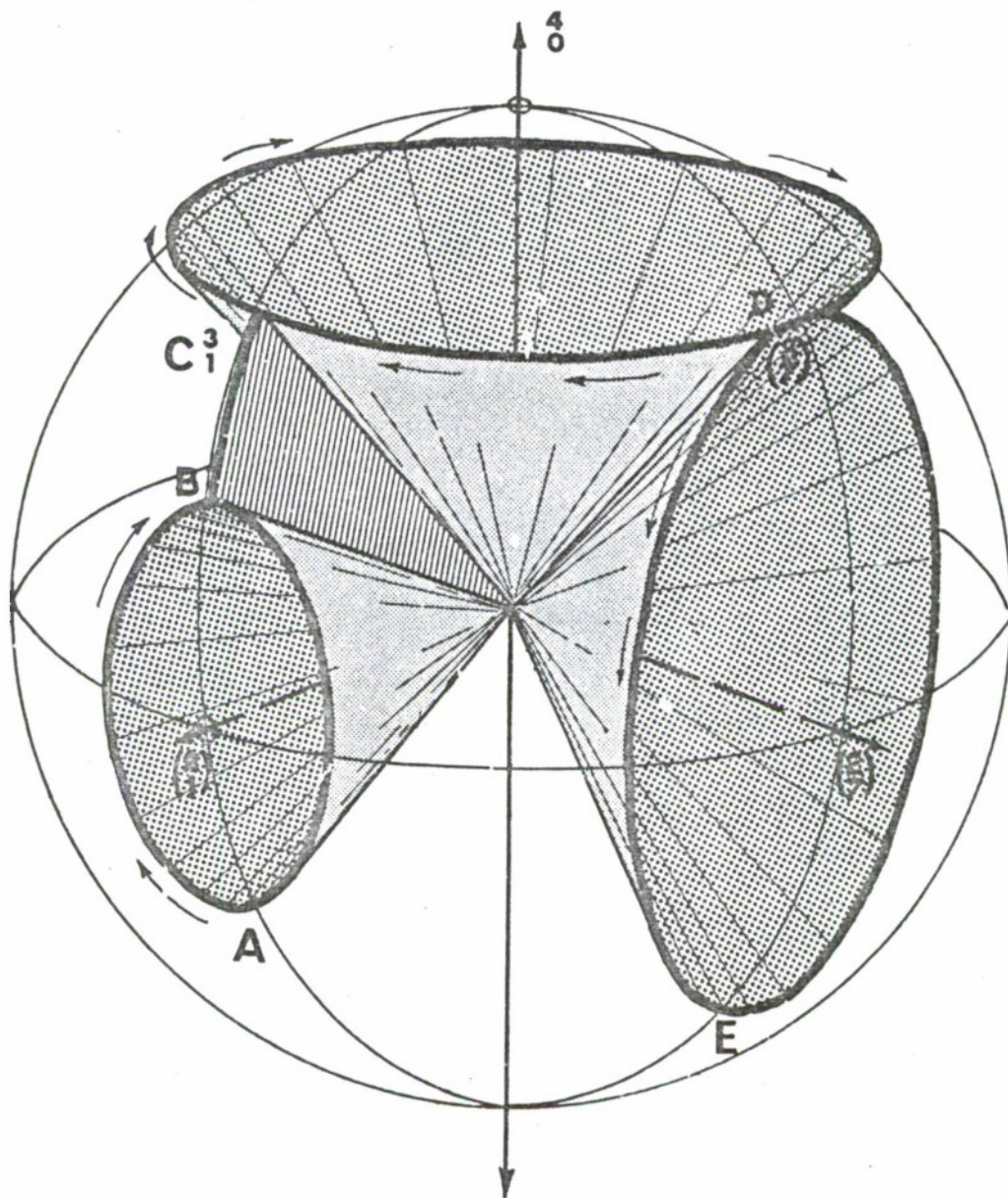

Figure 28.

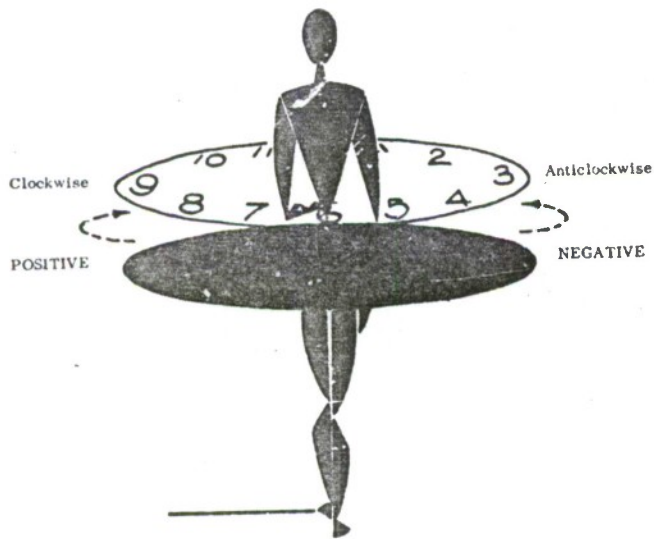

Figure 29.

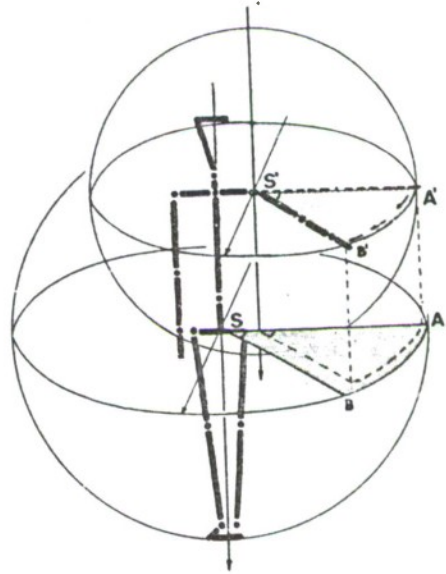

Figure 30.

sense is the direction upward from $\begin{pmatrix} 0 \\ 0 \end{pmatrix}$, in the given plane. The opposite direction in the same plane is the negative sense.

To notate vertical plane movement, it is necessary to indicate:

- a) in which plane the limb moves
- b) the sense of movement in that plane.

Positive vertical plane movement is written \uparrow . Negative vertical plane movement is written \downarrow .

In Figure 32 the movement from A to B in plane (2), and from A' to B' in plane (7) is in the positive sense: (2) \uparrow , (7) \uparrow . The movement from B to A in plane (2), and from B' to A' in plane (7) is in negative sense.

7.5 Intermediate Plane Movement.

Intermediate plane movement is movement in a plane tilted towards the horizontal plane. A limb can move in intermediate plane movement from any position excepting the vertically upward or downward positions (from which the only plane movement that can be performed is vertical plane movement.) (See Figure 33.)

Since intermediate plane movement is composed of two components--horizontal shift and vertical shift--four combinations of sense are therefore possible:

- 1) Positive horizontal component + positive vertical component; in the figure, from E to F. Symbol: \nearrow

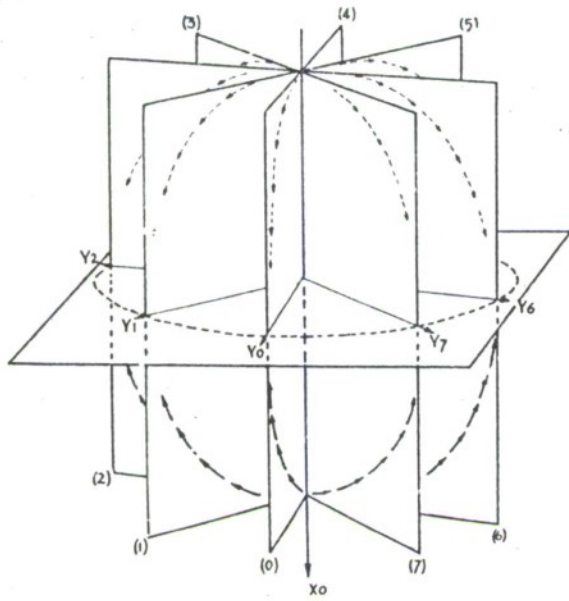

Sense of Movement :
 POSITIVE ↑
 NEGATIVE ↓

Figure 31.

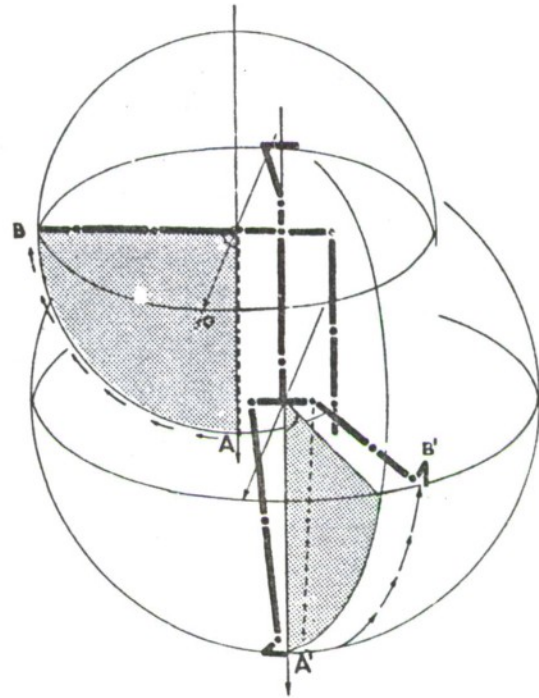

Figure 32.

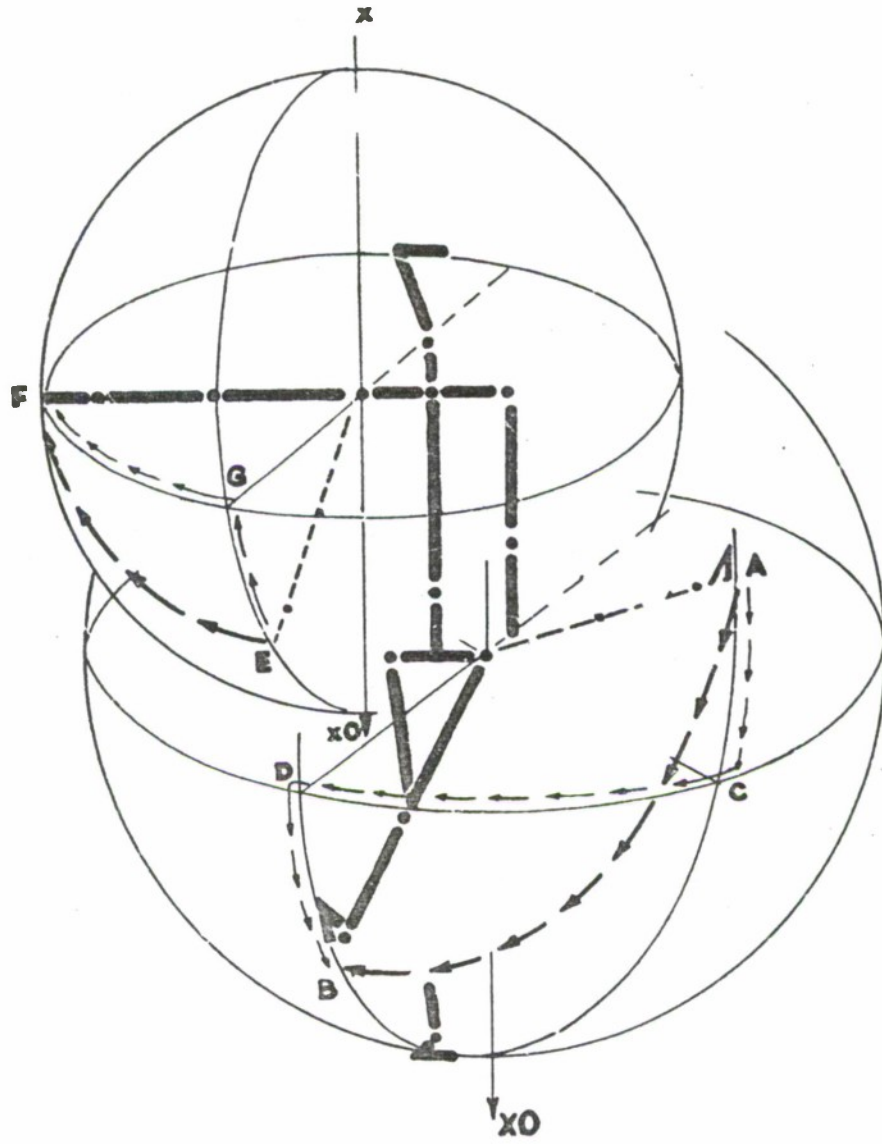

Figure 33.

- 2) Positive horizontal component + negative vertical component; in the figure, from A to B. Symbol: ↘
- 3) Negative horizontal component + positive vertical component; in the figure, from B to A. Symbol: ↙
- 4) Negative horizontal component + negative vertical component; in the figure, from F to E. Symbol: ↙

N.B. In the present book, the following convention is used in writing intermediate planes: the symbol $\begin{pmatrix} 3 \\ 2 \end{pmatrix}$ for example, indicates movement in an intermediate plane in the positive sense from a given starting position, to the position written above the flighted arrow. The movement may be continued in the same plane according to an amount of movement appended: e.g., $\begin{pmatrix} 3 \\ 2 \end{pmatrix} 8$.

VIII. THE NOTATION OF MOVEMENT: AMOUNT OF MOVEMENT

All the types of movement enumerated, being circular, are movements which may complete circles of 360°. Any movement performed, then, completes either a whole circle, or part of a circle, or a number of circles. The amount of movement thus expresses the size of the path (movement sector) which the limb in fact performs. In rotatory movement the amount of movement is that part of a complete rotation or the number of rotations performed by the limb. In plane movement the amount of movement is the size of the circular plane sector

of the movement of the limb. In conical movement the amount of movement is that part of the conical envelope produced by the movement; or in other words the size of the arc passed through by the extremity of the limb in its movement at the base of the cone.

The units of measurement of movement are the same units used in the construction of the coordinative network of the system of reference, since we assume that movements are performed between the points of the network. In rotatory movement the amount of movement is indicated by a numeral expressing the number of units of measure, attached to the movement sign. For example, a rotatory movement with the amount of two units (a movement of 90° when the basic unit is 45°) is written $\hat{2}$. In horizontal and vertical plane movement the amount is indicated by attaching the numeral to the arrow: on the right in vertical plane movement and above in horizontal plane movement: $\uparrow 2$ $\downarrow 2$ $\xrightarrow{2}$ $\xleftarrow{2}$. In intermediate plane movement the notation of the movement is divided between two numbers: one, written beneath the movement sign, expresses the amount of horizontal projection (shift) of the movement. The other, written above the movement sign, expresses the amount of the vertical projection (shift) of the movement. For example: $\frac{2}{2}$. In conical movement the amount of movement is added at the right side of the movement symbol. For example: $\wedge 2$. Figure 34 provides an example of movement sectors in full notation - the path and its reverse.

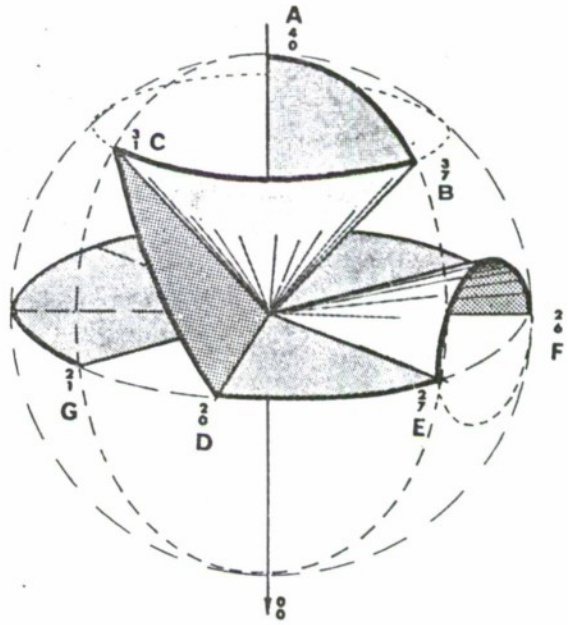
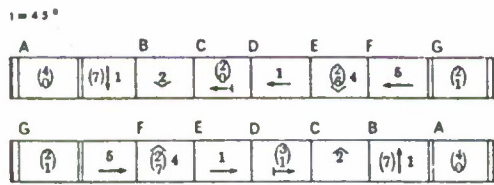

Figure 34.

IX. SIMULTANEOUS MOVEMENT

In Figures 35-36, in every movement performed by the body (other than the extreme outer limbs), two kinds of limbs take part: the actively moving limb (the "heavy" limb), and all those limbs carried by it (the "light" limbs).

The light limbs, carried by the heavy limb, change their location in space as the result of the movement of the heavy limb. (See Figure 35, in which the torso is "heavy" and all the upper parts of the body are "light".) In this case, only the movement of the light limbs is written. However, independent movement of the light limbs is possible while they are being carried by the heavy limb, and the change of location of each of them in space is then a result of the simultaneous movement of the heavy limb plus the movement of the light limb (see Figure 36). In this case the movement of each limb is written in its space.

Situations are possible, in which we are concerned to retain a given position in the light limb relative to the system of reference, while it is carried passively by the heavy limb. In these situations, the symbol f is attached to the notated position of the light limb. When the sign f is attached to a movement sign, this signifies that the path of the movement of the light limb is not modified by the movement of the heavy limb.



Figure 35.



Figure 36.

X. THE WEIGHT

Shift of weight is indicated in the second space from the bottom of the page. Although physically speaking shift of weight is always present when the body is in movement, in the notation it is written only when it is visually predominant, or when it offers the most concise way of indicating an action, such as walking, jumping, etc.

Equal distribution of the weight of the body is indicated by the symbol \cdot . When the weight is shifted, the projection of the longitudinal axis of the body on the horizontal plane coincides with one of the horizontal coordinates. This coordinate is identified as usual, by counting in the positive sense according to the scale in use. For instance, a shift of weight forward from zero position is written as 0 in the space reserved for shift of weight. (See Figure 37.)

In notating a series of steps in the same direction, the following convention is adopted: the steps are indicated by the compound symbol



abbreviated from the symbols used in writing in full the movements of flexion and extension in walking. Together with this, a number in the weight space shows the horizontal direction in which the weight is shifted throughout the movement sequence.

A number accompanied by the sign M (maximum) represents a shift of weight such as occurs in falling. (This falling

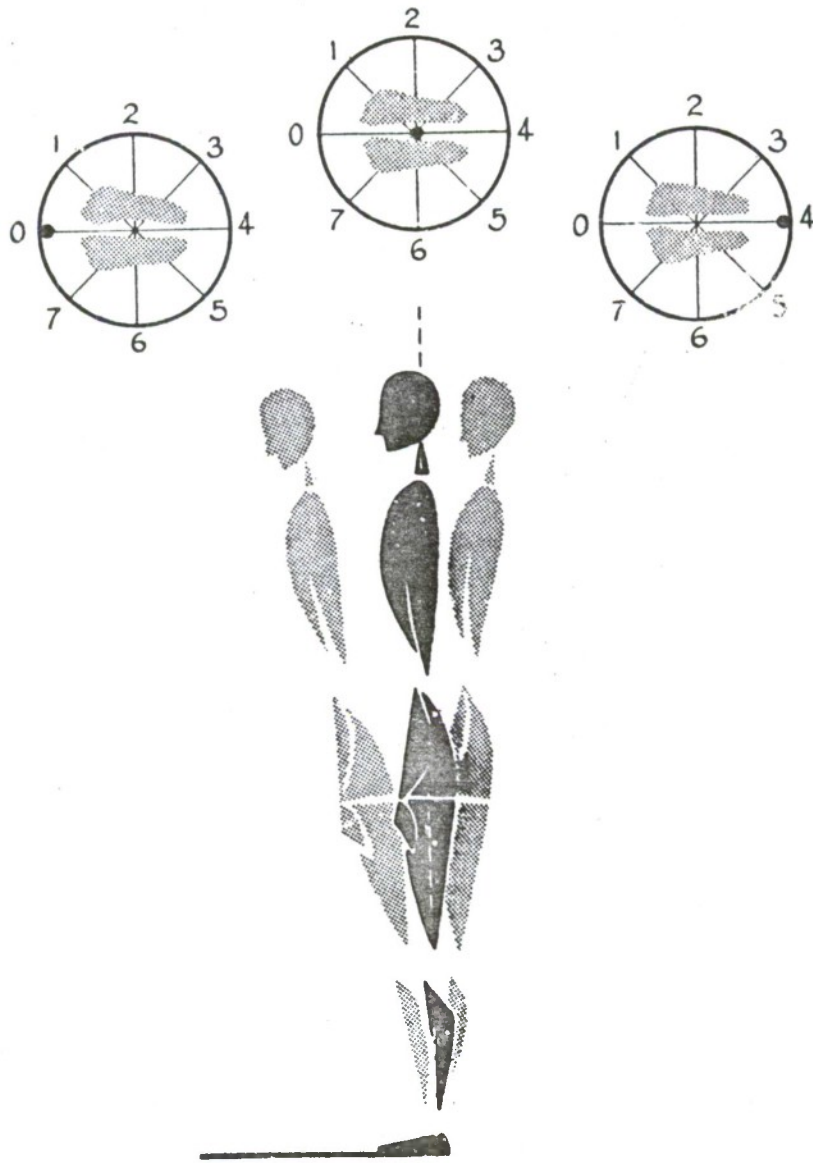

Figure 37.

movement is of course controlled in dance, by means of the action which follows it.)

The phenomenon of the jump, in which all contact with the ground is abandoned, is written in the weight space, using the symbol (=), derived from the symbol for absence of contact =. A jump in a given direction is shown by a number indicating the appropriate horizontal coordinate, e.g., ($\overset{2}{=}$).

XI. CONTACT

The sign for contact is \uparrow , with its derivatives. Contact for a part of the body with the ground is shown by the sign \uparrow in the appropriate space. Thus, in standing positions the sign appears in the spaces allotted to the feet.

Contact between parts of the body is shown by one of the other three forms \uparrow \pm \downarrow written in the spaces of both the limbs involved. A number shows which side of each limb is in contact. For example, contact between the palms of the hands would be written:

Left hand 2 \uparrow
Right hand 6 \uparrow

Contact of the extreme end of a limb (such as finger tips, or the "points" in Classical Ballet) is written $\dot{\uparrow}$ or $\downarrow\cdot$. Release of contact is written =. When the foot is in contact with the ground, but does not bear weight, this is indicated by the sign $\overline{\uparrow}$.

"Loose" contact, written L, is contact in which a limb or limbs are in contact with another surface, but move upon it. For instance, in rotation of the whole body with a foot as base, the sign L appears in the space for that foot. To indicate holding, the sign used is \lfloor . Figure 38 illustrates some examples of contact with the ground.

XII. FRONT

In the lowest space on the manuscript page, four types of symbols may appear: numbers without brackets, numbers with brackets, the symbols for rotation (such as $\widehat{2}$, $\underline{4}$, etc.), and the symbol for rotation about the lateral axis--"vertical rotation": \uparrow .

In zero position the body is placed so that the horizontal direction 0 of the system of reference coincides with the direction forward from the body, and towards the observer. If, for purposes of analysis, it is required to reorientate the system of reference relative to this absolute zero position, the new front--the direction in which the 0 of the system faces--is indicated by a number without brackets.

From this point in the score, all movements would be written in relation to the new direction.

A number enclosed in brackets indicates the front of the body in relation to the 0 direction of the system of reference. Thus, with the system of reference orientated towards the observer, a position in which the body is in profile facing

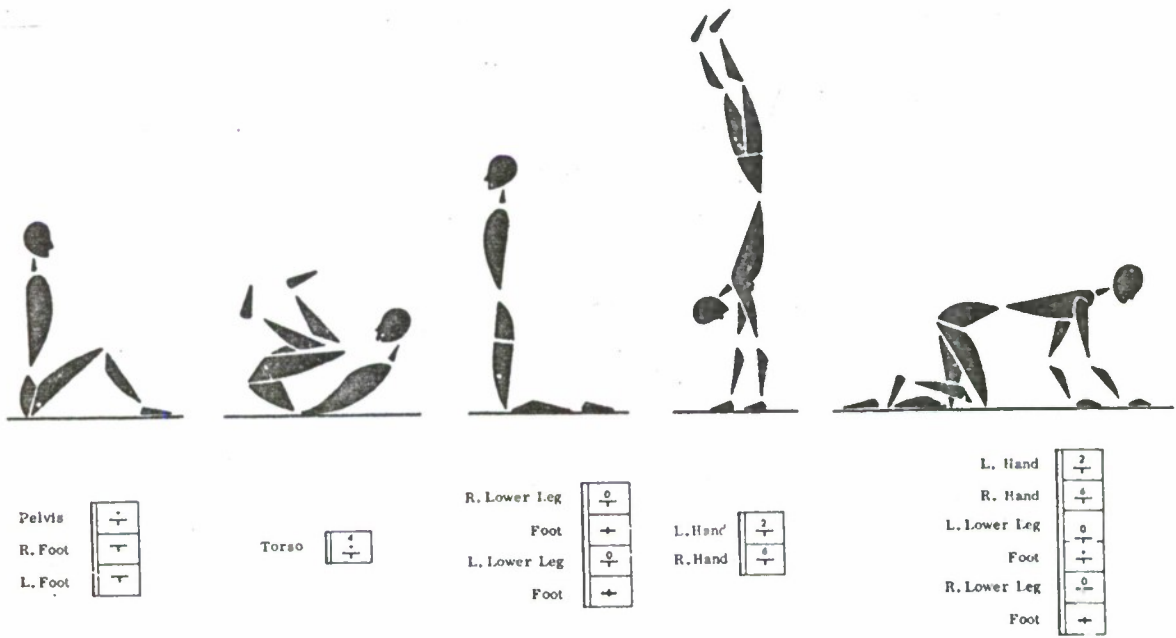

Figure 38.

the observer's left, would be indicated by (2) in the "front" space.

When a rotation of the whole body occurs, this continuous change of front is written as a rotation in the "front" space, and the "loose contact" sign L is given to the part of the body which serves as base.

Rotatory movement is by definition movement about the longitudinal axis of the limb, but there are certain complex actions (such as forward and backward rolls, somersaults, etc.), in which the body as a whole rotates about its lateral axis. This is represented by the symbol \Uparrow (positive) and \Downarrow (negative), a composite derived from the signs of vertical plane movement and rotatory movement.

XIII. CONVENTIONS

13.1 Abbreviations.

(2 \uparrow) - a device serving as a "key" signature, given before the movement sequence. It indicates that all vertical plane movements with no bracketed number preceding the arrow are to be performed in the plane indicated here. In the example given, this is plane (2).

$f_{(0)}^4$ - fixation may also precede a sequence, attached to a limb or limbs which are to remain in a constant relation to the system of reference despite movements of heavier limbs. For instance, the example shown, would indicate that by continuous adjustment the limb is maintained upright throughout the sequence.

13.2 Amounts of Movement.

When no amount is indicated, the magnitude of the movement is less than one unit.

- m indicates the smallest amount possible.
- M indicates the largest amount possible within the range of the joint involved.
- appended to a number signifies slightly less than the amount expressed by the number.
- + appended to a number signifies slightly more than the amount expressed by the number.

These last two are particularly useful in the notation of positions.

13.3 Parts of the Body - Special Cases.

The sign \downarrow in the lower leg, appearing without indication of plane, expresses flexion of the lower leg towards the upper. The sign \uparrow expresses extension. The principle underlying this convention is taken from the fact that from zero position, these would be the appropriate directions for the arrow in writing these movements in plane (0).

By application of the same principle to the foot, \uparrow indicates flexion towards the lower leg; \downarrow indicates extension.

The sign $\begin{matrix} \downarrow \\ \uparrow \end{matrix}$ appearing on the line separating the upper and lower leg spaces, without indication of plane, indicates knee flexion. Similarly, the sign $\begin{matrix} \uparrow \\ \downarrow \end{matrix}$ indicates extension of

the knee. These signs are derived from the full notation of the same movements in zero position.

The symbol \times indicates "contraction". The two extremities of the long axis of the torso--or of a part of the torso--approach one another in the same plane and with equal amounts of movement in opposite senses. The upper part moves in negative sense; the lower part in positive sense. The amount is written following the sign. For example, (2) \times M indicates a contraction in plane (2), with maximal amount of movement, resulting in a concave curve to that side of the body. (The form of the symbol is based on the arrow-heads of plane movement signs, positive and negative.)

13.4 Auxilliary Signs.

When a movement or position in one plane involves the crossing of the legs or the arms, an asterisk * is written in the space of the limb which is to be in front of the other. The symbol $\}$ indicates that an over-all rounded shape is given to the position of several adjacent limbs (such as upper arm, forearm, hand) by slight flexion of all its joints. The symbol \lceil indicates that several adjacent limbs are in a straight line. These two symbols are primitive alternatives for the sign \times ; in most cases it is preferable to use the latter.

Whenever necessary, the space allocated to each limb has been identified in the notation score, using the following abbreviations:

F	right	sh.	shoulder
L	left	hd.	head
fg.	fingers	n.	neck
1	thumb	tso.	torso
2	index	plv.	pelvis
3	middle	u.lg.	upper leg
4	ring	l.lg.	lower leg
5	little	ft.	foot
h.	hand	wt.	weight
f.a.	forearm	fr.	front
u.a.	upper arm		

PART B

MACHINE REPRESENTATIONS OF MOVEMENTS

(Michl and Melvin)

PRECEDING PAGE BLANK

MACHINE REPRESENTATIONS OF MOVEMENTS

The Eshkol-Wachmann (E-W) notation described is a position orientated notation in that the trajectory of the body can be computed exactly, and not a goal orientated notation as would be a notation which would specify that a certain event take place without indicating an exact manner of accomplishing it. As an example consider the differences between the order "starting with your arm vertically down make a vertical circle with your left hand, with your shoulders on the axis of the circle" and the order, "sit down on this chair". Absolute control over every movement is necessary for the first command to be obeyed, while in the second case, any manner of sitting down will be satisfactory as long as the goal is accomplished. Miss Eshkol is presently working on goal orientated features for the E-W notation, but as of now the only way to command a move to a prescribed position by E-W notation is to describe a string of commands which lead to it, and the only way to predict the results of a string of commands is by simulating movement on a model or by educated guessing.

For these reasons it seemed desirable to devise a simulator to study the potential of existing E-W commands. Use of human objects or mechanical models has several drawbacks, the most notable being the difficulty of recording observed data. Hand sketching projections of simple movements were

PRECEDING PAGE BLANK

made by Mr. Wachmann, and proved very satisfactory although too time consuming because of the computations involved. It was decided to write a computer program named DANCER which would speed the process up. Use of the computer provides accurate results, the possibility of processing large amounts of data in relatively little time, and direct graphical output through the use of a plotter attached to a main computer. An added advantage is insight gained into the logic of the notation by translating it into the purely abstract mathematical form of a computer program. Some of the knowledge acquired during the writing of DANCER was applied to the writing of a second computer program called STKMAN*, which uses different mathematical coordinates and provides the possibility of goal-like commands. Both computer programs will be described after brief discussions on the physiology of movement and mathematical abstraction of the body.

I. PHYSIOLOGY OF MOVEMENT

Movement of the human body is, like all biological phenomena, the result of complex processes structured in such a manner as to allow maximum efficiency and integration of functions in view of a given goal. In watching a human body move an observer will only perceive the external

*Computer abbreviation of STICKMAN.

manifestations of movement and will, most of the time, remain totally unconcerned with the neural and muscular phenomena involved. Yet all movement does originate at the neural level and is only translated into visible phenomena after action by the muscles.

These simple facts suggest a hierarchical organization for the study of movement:

- 1) Volition of movement (neural level)
- 2) Execution of movement (muscular level)
- 3) Effect of movement (externally perceived movement)

The first level is that of the neurologist's or psychologist's. We will only retain a few observations made by neurologists concerning the functioning of the brain, mainly that nervous activity is in the form of electric-like waveforms and that the cerebellum acts as a filter and coordinator of movement commands. We will examine some of the consequences of this a bit later.

The second level is of somewhat more concern to us. The joints of the human body do not allow absolutely free movements--it is impossible, for instance, to throw one's leg backwards as far as forward, and the muscular arrangement of the body reflects these dispositions. Although we later offer a simplified model of the human body which gives all joints maximum freedom of movement we do so only while keeping in mind that a great many constraints do exist. Some ways

of adding constraints to the programs and notations are indicated in Section V.

Level 3 will be our most immediate area of concern: the configuration of the human body in space. We can define a movement notation as states of the human body combined with transitions between states. In the E-W notation, movements and positions of each limb are given by the locus of points traced by one end of the limb on its inscribed sphere. In the SPKMAN system, positions and changes are given in terms of angles between connecting limbs. In both cases, the type of commands depends upon the mathematical system used to represent the body.

II. MATHEMATICAL ABSTRACTION OF THE HUMAN BODY

Since the human body is only capable of a finite number of positions, assuming that two positions must be discernible to the eye to quality as different, we will in fact be dealing with the study of the human body as a finite state automaton. We are unconcerned with the biological phenomena which permit the execution of transitions between states, but rather we wish to examine the external states adopted by the body during transitions. In using this approach, a first problem is how to sufficiently abstract the human body so that it may be represented as a reasonably simple system and be conveniently handled in mathematical terms.

A first observation is that most large bones are long and cylindrical, and can be approximated by a long, thin rods. Since the amount of soft tissues is approximately proportional to the size of the bones supporting them, parts of the body may be reasonably approximated by homogeneous rods. Notable exceptions such as the head, hands, feet, pelvis or torso can also be worked into this scheme by approximating them as thick cylinders and taking their main axis as rods, and furthermore in the case of the pelvis and torso, by adding additional points of contact with other parts on the surface of the cylinder itself making an assemblage of three rods (see Figure 1).

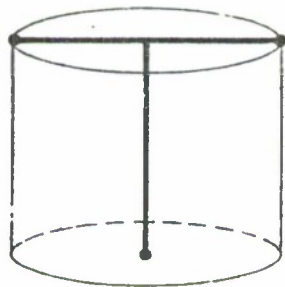

Torso



Pelvis

Figure 1. Approximations to torso and pelvis.

A very acceptable representation of the whole body is then an assemblage of stick like rods (see Figure 2). This representation is the basis of the STKMAN notation and is also used by the E-W notational scheme where limbs are often approximated by rods. We will henceforth call any of these rods "limbs".

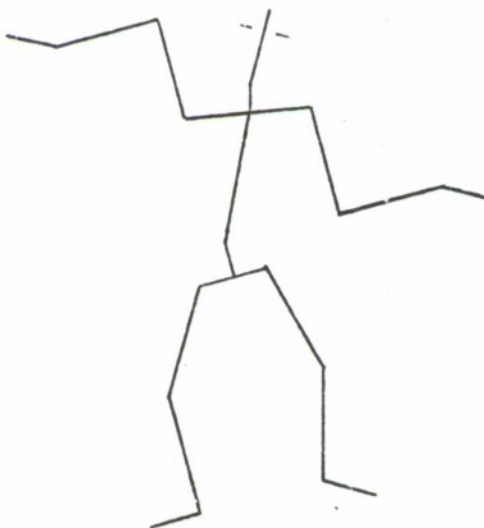

Figure 2. Stick approximation to the body.

Study of such a system can be of a dynamic or kinematic nature. In the first case, the rods are assumed to have mass and all forces acting upon the system as well as muscular velocities must be known or computed to obtain the proper trajectories of the limbs. In a kinematic study the limbs are assumed to have no weight. Thus the only computations necessary are those which determine the position of the system.

Such a simplification is possible if we disallow harsh or jerky motions and hard contact of the system with immobile

objects, since important dynamic forces come into play in such circumstances. We are, in fact, specifying that only smooth and relatively slow movements be allowed.

That most movements of the body are in fact relatively smooth is due to the cerebellum and the dynamics of the body.

The nervous system smooths and coordinates neural commands by action of the cerebellum. Damage to this organ will result in incapacitating a patient by rendering smooth movements impossible and hindering coordination. An example of the amount of smoothing involved is provided in the articles by Denier van der Gon and Thuring (1965) and Denier van der Gon, et al. (1962) concerning the design of a handwriting simulator, where it is shown that even such an apparently staggered event as a signature can be simulated by a machine fed with a fairly uncomplicated and smooth signal. This indicates that smooth motions demand very smooth neural signals and that a great deal of neural coordination is built into any movement.

Assuming that commands for jerky motions are eliminated, command for a smooth movement may still result in jerky motion if the acceleration of the moving limbs is too large. A basic law of physics states that $a = \frac{F}{m}$ where a is acceleration, F force applied to the object and m the mass of the object. Since both F and m have a limited range of values for a given limb and its muscles, a will have a

limited range unless the limb is acted upon by outside forces, and moving additional attached limbs will decrease a even more. α will then be limited if the desired motion is not too harsh.

In the case of a large m , the influence of gravity becomes of some concern. Gravity's effect is minimized by the fact that the larger and hence heavier parts of the body are closer to the body's center of gravity than lighter parts. Light parts do not then usually move heavier ones. There are notable exceptions to this rule, such as in walking, and we may cover these exceptions by assuming that the body is not coming into contact with immobile objects. Walking, then, can simply be construed as being the raising and lowering of the feet by the body.

Given a kinematic system of connected sticks we have a basic structure with which to simulate movement of the body. Computer simulation of such a system will be based on storing sufficient information to completely define the system at given intervals of time. The E-W and STKMAN simulators store positions of limbs in a large array, each set of positions corresponding to the state of the system at a given time. This information can then be graphed to provide either these states at these timesteps or the trajectory of each limb, which can be printed or plotted accordingly. (See Figure 3.) The two methods are combined in DANCER to provide maximum information on the plots.

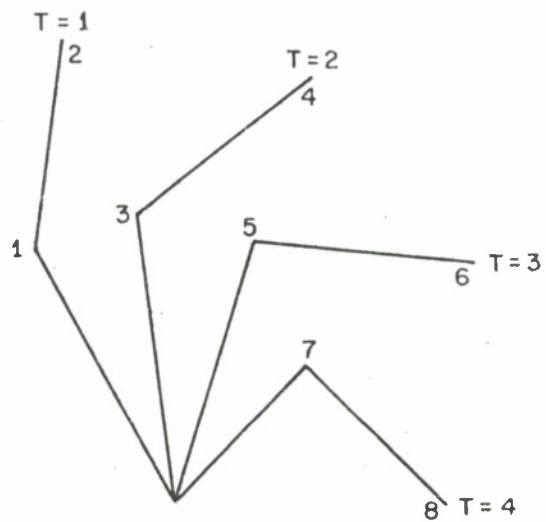

The State of the System at Specified Times.

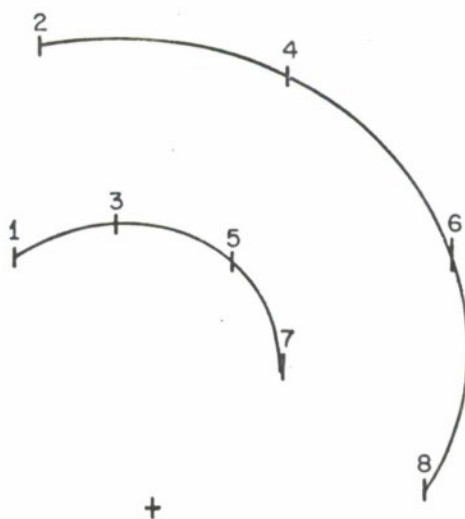

Figure 3. The Space Curves of Two Limbs Executing the Same Movements as Above.

A system of n limbs will require at least $3(n+1)$ numbers to be defined. We need to know the position of one point of the system, and this point will act as a reference point for the system. Given this first point, we can construct a first limb originating from it by defining another point in space, or by defining the length and direction of the limb. In each case three numbers are needed since defining a direction in space requires two numbers. One can then define new limbs which originate from either point given once again a new triplet of numbers. (See Figure 4.) Accordingly the arrays used to store information in DANCER and STKMAN are both dimensioned 3 by $(n+1)$ where n is the number of limbs in the system.

The main task of both programs consists of keeping track of the positions of the limbs and joints as commands are simulated.

III. THE E-W PROGRAM: DANCER

Two important aspects of the E-W notation are that the spheres in which limbs are inscribed are of fixed diameter and that the spheres have their south pole facing down vertically at all times. Given a fixed, or reference, point in the system, the position of other points can easily be computed given the E-W position of the limbs, their length and the unit angle used. Given 2 angles, a and b , and a length, l ,

A LIMB CAN BE DEFINED USING:

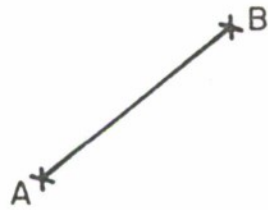

Two Points A and B

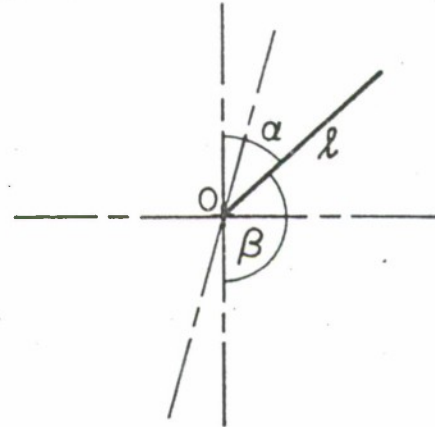

One Point O, Two Angles α , β
and a Length l

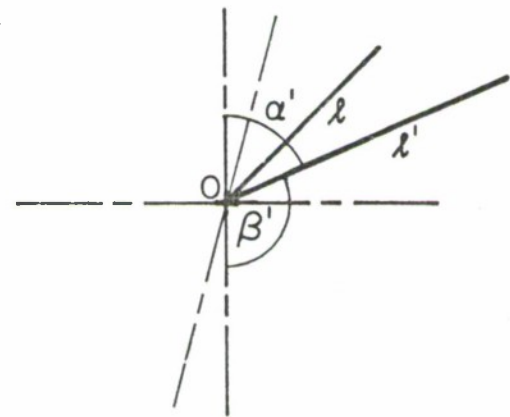

Figure 4. Any additional limb attached to a given extremity of a single limb or node of a system, will require either an additional point, or two angles and a length to be defined.

which determine a limb centered in O, to determine E in rectangular coordinates, with u the unit angle in radians:

$$E_x = l \cos(bu - \frac{\pi}{2}) \sin(-au) + O_x$$

$$E_y = l \cos(bu - \frac{\pi}{2}) \cos(-au) + O_y$$

$$E_z = l \sin(bu - \frac{\pi}{2}) + O_z$$

(See Figure 5.) If another limb is added to OE, the same computation is repeated, replacing O_x, O_y, O_z by E_x, E_y, E_z , and a, b and l by their new values for the new limbs.

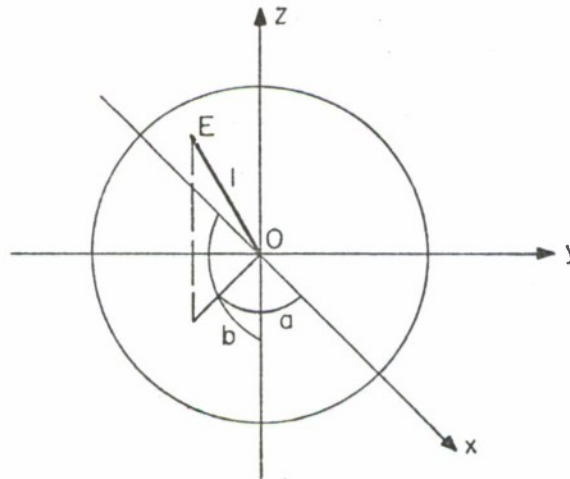

Figure 5. Representation of a limb.

Throughout these examples, we will hold the unit angle fixed at 45° , although full provision is made in the program for any divisor of 360° . We will call the origin of the system the fixed reference point and the origin of a limb the closest extremity to the absolute origin along the broken line consisting of interconnected limbs.

A limb's origin is a pivot point for the limb and is the center of the enclosing sphere. We number limbs in sequence, beginning with the limb attached to the absolute origin, and call a low numbered limb a heavier limb than a higher numbered one. We restrict ourselves to systems of interconnected limbs with no more than 2 limbs stemming from any function of limbs. This does not permit representation of the whole body, which is treated in STKMAN, but the system could have been expanded in order to do so. However, the main purpose of the E-W simulator is to study results of simultaneous E-W commands on interconnected limbs.

Commands used are input to the computer indicating for each limb the beginning position, the type of movement, the total amount of movement in degrees and at what timestep this movement ends. Each limb may execute different movements sequentially. The types of movement allowed, with their coded number representations, are:

- 0 = no movement
- 1 = planar movement
- 2 = conical movement
- 3 = rotatory movement
- 4 = planar movement with rotation
- 5 = conical movement with rotation

As defined in E-W notation, to indicate the locus of the movement in case of planar or conical commands, an auxiliary point is to be given and treated in the following manner:

- 1) If the movement is a planar one, the auxiliary point is any point on the circle, other than the starting point or the other end of a diameter through the starting point. A center and two distinct points on the circumference fully define a circle (Figure 6).

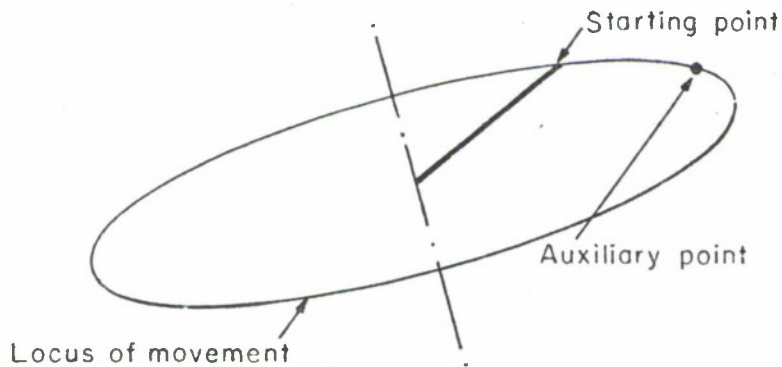

Figure 6. Planar movement.

- 2) If the movement is a conical one, the auxiliary point is taken to determine the diameter of a circle intersecting the axis of the cone perpendicularly. Given the apex and this diameter, the cone is uniquely determined (Figure 7).

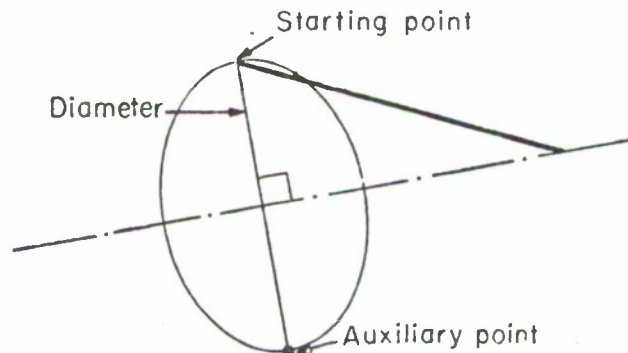

Figure 7. Conical movement.

Timesteps were determined by a rule of thumb which indicated that a rotation of 5° per timestep provided smooth curves when space curves were plotted. Since different limbs were given different velocities, it was decided to input this factor with the data instead of having it as a fixed or machine computed constant.

When reading in the data, the program creates a list of type and amount of movement for each limb at each timestep. The amount of movement is simply the total amount of the specific movement divided by the number of timesteps that type is to occur.

Actual computation of new positions is by use of a rotational matrix which rotates the moving limb, its intermediary point and all limbs lighter than the one in motion.

The computation depends on determination of the axis of rotation. For planar movement, this is the perpendicular to the plane of the circle at the center. For conical movement, it is the axis of the cone. The system is translated until the pivot point of the moving limb is at the origin. The whole system is then rotated about the z axis and x axis until the axis of rotation coincides with the Oz axis. The system is then rotated in the proper amount about the Oz axis and is rotated and translated back to its original position by reversing the previous steps. The matrix used for rotation is (Goldstein, 1950):

$$A = \begin{pmatrix} \cos\psi \cos\phi & \cos\psi \sin\phi & \sin\psi \sin\theta \\ -\cos\theta \sin\phi \sin\psi & +\cos\theta \cos\phi \sin\psi & \\ -\sin\psi \cos\phi & -\sin\psi \sin\phi & \cos\psi \sin\theta \\ -\cos\theta \sin\phi \cos\psi & +\cos\theta \cos\phi \cos\psi & \\ \sin\theta \sin\phi & -\sin\theta \cos\phi & \cos\theta \end{pmatrix}$$

The angles ϕ , ψ and θ are defined on Figure 8.

This matrix is the product of three matrices B, C and D defined in the following manner (Goldstein, 1950).

Rotation about Oz:

$$D = \begin{pmatrix} \cos\phi & \sin\phi & 0 \\ -\sin\phi & \cos\phi & 0 \\ 0 & 0 & 1 \end{pmatrix}$$

Rotation about Ox:

$$C = \begin{pmatrix} 1 & 0 & 0 \\ 0 & \cos\theta & \sin\theta \\ 0 & -\sin\theta & \cos\theta \end{pmatrix}$$

Rotation about δ :

$$B = \begin{pmatrix} \cos\psi & \sin\psi & 0 \\ -\sin\psi & \cos\psi & 0 \\ 0 & 0 & 1 \end{pmatrix}$$

(Using the notation of Figure 8.) Applying $D^{-1}C^{-1}$ then rotates the system back into its original position.

For any given timestep, if the system contains n limbs, limb 1 is moved first and with it the entire system, then limb 2 and the entire system less limb 1, etc., until limb n ,

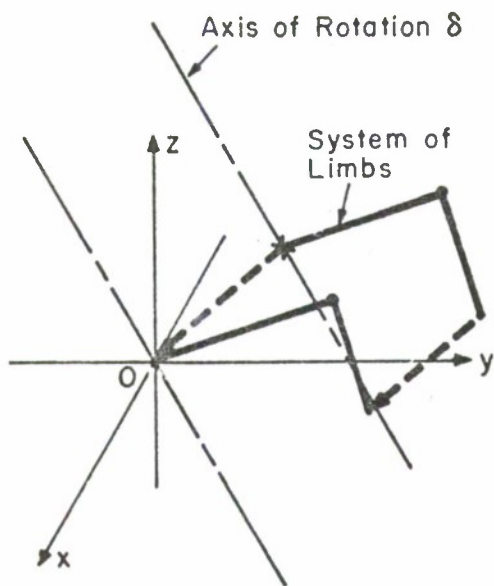

1) The Limbs are Translated Until Origin of Moving Limb is at Origin of Coordinate System.

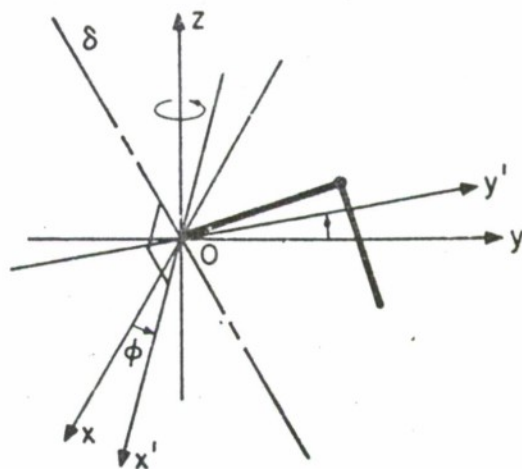

2) The System is Rotated About OZ Until OX' is Perpendicular to δ . The Amount of Rotation is ϕ .

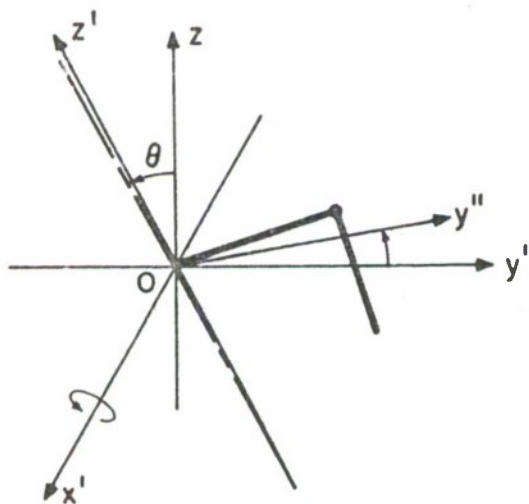

3) This System is Rotated About OX' Until OZ Coincides with δ . The Amount of Rotation is θ .

Any Rotation About OZ' Will Now be Equivalent to a Rotation About δ . This Rotation is ψ .

Figure 8. Rotation about a given axis.

the lightest limb, which carries no other limbs, is moved. The program then executes commands for the following time-step until all timesteps for all limbs have been exhausted.

Input is permissible in E-W coordinates or rectangular coordinates. In the event E-W coordinates are used, the unit angle has a default value of 45° unless otherwise specified, and a subroutine, named TRANSL, translates the input into rectangular coordinate values. Results come out as a printed table of positions for given times in rectangular and spherical coordinates. Note that spherical coordinate angles are not taken in the same direction as E-W coordinates: viewed from the top, the horizontal angle sweeps counter-clockwise, while in E-W it sweeps clockwise. Similarly, zero degrees is vertical down in E-W, vertically up in spherical for the vertical angle. Results are also obtained as plots of the space curves created by the joints of the limbs. Supplementary lines are drawn connecting points representing simultaneous times on different trajectories. The number of these is variable, and several features help enhance the plot. As an example of possible representations of the same movement, Figures 9 through 12c show results obtained from a typical 2 limb case. All plots are projections onto three imaginary perpendicular planes, two vertical and one horizontal. The two limbs are executing cones. The corresponding E-W command is

$$\begin{array}{ccc}
 & & l = 45^\circ \\
 \begin{pmatrix} 1 \\ 1 \end{pmatrix} & \left| \begin{array}{c} | \\ | \end{array} \right. & \begin{pmatrix} 2 \\ 3 \end{pmatrix} \& \\
 \begin{pmatrix} 4 \\ 4 \end{pmatrix} & & \begin{pmatrix} 2 \\ 2 \end{pmatrix} \downarrow 4
 \end{array}$$

The first limb is executing a cone of $8 \times 45 = 360^\circ$, the second limb a cone of $4 \times 45 = 180^\circ$, starting from positions $\begin{pmatrix} 1 \\ 1 \end{pmatrix}$ and $\begin{pmatrix} 4 \\ 4 \end{pmatrix}$ respectively, and going through points $\begin{pmatrix} 2 \\ 3 \end{pmatrix}$ and $\begin{pmatrix} 2 \\ 2 \end{pmatrix}$.

In Figures 10a,b,c, the circular parts represent the trajectories of the limbs extremities. The numbers indicate the position of the limb such that every fifth timestep is indicated and the states of the limbs are indicated at every timestep. The numbers still refer to every fifth timestep and the axes have been deleted. The axes are not needed if one wants positions in terms of angles.

In Figures 12a,b,c, only the outermost trajectory is joined to the center point. This is to allow an easier identification of the trajectory's shape.

All figures are automatically scaled and the axes numbers adjusted accordingly, when the axes are used.

Printed output indicates the options used and movements specified on the title page. It then provides, for each limb, the position and direction of each limb of each timestep. The extremity of each limb is given by a triplet, the origin of the limb being either the system's origin in the

COORDINATES OF LIMB NUMBER 1					
	X	Y	Z	HORI	VERT
0	-0.000	-0.707	0.707	-90	45
1	0.058	-0.693	0.728	-85	43
2	0.117	-0.655	0.743	-80	42
3	0.178	-0.634	0.753	-74	41
4	0.239	-0.608	0.757	-69	41
5	0.300	-0.583	0.755	-63	41
6	0.360	-0.558	0.748	-57	42
7	0.420	-0.533	0.734	-52	43
8	0.478	-0.509	0.716	-47	44
9	0.535	-0.485	0.691	-42	46
10	0.590	-0.463	0.662	-38	49
11	0.642	-0.441	0.627	-35	51
12	0.691	-0.421	0.588	-31	54
13	0.736	-0.402	0.544	-29	57
14	0.778	-0.385	0.496	-26	60
15	0.816	-0.369	0.444	-24	64
16	0.850	-0.355	0.389	-23	67
17	0.879	-0.343	0.331	-21	71
18	0.903	-0.333	0.271	-20	74
19	0.923	-0.325	0.208	-19	78
20	0.937	-0.319	0.144	-19	82
21	0.946	-0.315	0.078	-18	86
22	0.949	-0.314	0.012	-18	89
23	0.948	-0.315	-0.054	-18	93
24	0.941	-0.317	-0.119	-19	97
25	0.929	-0.322	-0.184	-19	101
26	0.911	-0.330	-0.247	-20	104
27	0.889	-0.339	-0.309	-21	108
28	0.861	-0.350	-0.368	-22	112
29	0.829	-0.364	-0.424	-24	115
30	0.793	-0.379	-0.477	-26	118
31	0.753	-0.395	-0.526	-28	122
32	0.708	-0.414	-0.572	-30	125
33	0.661	-0.433	-0.613	-33	128
34	0.610	-0.455	-0.649	-37	130
35	0.556	-0.477	-0.681	-41	133
36	0.500	-0.500	-0.707	-45	135
37	0.442	-0.524	-0.728	-50	137
38	0.383	-0.549	-0.743	-55	138
39	0.322	-0.574	-0.753	-61	139
40	0.261	-0.595	-0.757	-66	139
41	0.200	-0.624	-0.755	-72	139
42	0.140	-0.649	-0.748	-78	138
43	0.080	-0.674	-0.734	-83	137
44	0.022	-0.698	-0.716	-88	136
45	-0.035	-0.722	-0.691	-93	134
46	-0.090	-0.744	-0.662	-97	131
47	-0.142	-0.766	-0.627	-100	129

Figure 9. Computer printed output giving positions in rectangular coordinates and spherical angle: for each timestep.

48	-0.191	-C.786	-0.588	-104	126
49	-0.236	-C.805	-0.544	-106	123
50	-0.278	-0.822	-0.496	-109	120
51	-0.316	-C.828	-0.444	-111	116
52	-0.350	-C.852	-0.389	-112	113
53	-0.379	-C.864	-0.321	-114	109
54	-0.403	-C.874	-0.271	-115	106
55	-0.423	-C.882	-0.208	-116	102
56	-0.437	-C.888	-0.144	-116	98
57	-0.446	-C.892	-0.078	-117	94
58	-0.449	-0.893	-0.012	-117	91
59	-0.448	-C.893	0.054	-117	87
60	-0.441	-C.890	0.119	-116	83
61	-0.429	-C.885	0.184	-116	79
62	-0.411	-C.877	0.247	-115	76
63	-0.389	-0.868	0.309	-114	72
64	-0.361	-C.857	0.368	-113	68
65	-0.329	-C.844	0.424	-111	65
66	-0.293	-0.829	0.477	-109	62
67	-0.253	-C.812	0.526	-107	58
68	-C.208	-C.793	0.572	-105	55
69	-0.161	-C.774	0.613	-102	52
70	-0.110	-C.753	0.649	-98	50
71	-0.056	-C.730	0.681	-94	47

COORDINATES OF LIMB NUMBER 2

	X	Y	Z	HORI	VERT
0	-C.000	-C.707	1.707	0	0
1	0.169	-C.650	1.721	16	7
2	0.338	-C.594	1.717	16	13
3	0.505	-0.540	1.693	16	20
4	0.669	-0.489	1.652	16	27
5	0.827	-C.440	1.593	15	33
6	0.977	-0.395	1.518	15	40
7	1.119	-0.355	1.427	14	46
8	1.250	-C.320	1.322	14	53
9	1.370	-C.290	1.205	13	59
10	1.478	-C.266	1.077	13	65
11	1.572	-0.248	0.939	12	72
12	1.652	-C.236	0.794	11	78
13	1.717	-C.232	0.643	10	84
14	1.767	-C.234	0.488	9	90
15	1.802	-0.242	0.321	7	97
16	1.821	-C.258	0.173	6	102
17	1.826	-C.280	0.017	4	108

18	1.817	-0.308	-0.135	2	114
19	1.794	-0.242	-0.283	-1	119
20	1.757	-0.382	-0.424	-4	125
21	1.709	-0.427	-0.558	-8	130
22	1.649	-0.477	-0.683	-13	134
23	1.580	-0.531	-0.758	-15	138
24	1.502	-0.589	-0.901	-26	141
25	1.416	-0.645	-0.993	-34	144
26	1.324	-0.713	-1.073	-43	146
27	1.228	-0.778	-1.141	-52	146
28	1.128	-0.844	-1.155	-62	146
29	1.026	-0.911	-1.237	-70	144
30	0.924	-0.978	-1.267	-78	142
31	0.821	-1.045	-1.284	-84	139
32	0.721	-1.110	-1.289	-89	136
33	0.623	-1.174	-1.284	-93	132
34	0.528	-1.237	-1.267	-96	128
35	0.438	-1.296	-1.242	-98	124
36	0.354	-1.354	-1.207	-100	120
37	0.275	-1.408	-1.165	-101	116
38	0.202	-1.459	-1.116	-101	112
39	0.136	-1.506	-1.061	-101	108
40	0.077	-1.551	-1.002	-101	104
41	0.025	-1.591	-0.935	-100	101
42	-0.021	-1.628	-0.874	-99	97
43	-0.060	-1.662	-0.806	-98	94
44	-0.092	-1.691	-0.738	-97	91
45	-0.118	-1.718	-0.670	-95	89
46	-0.139	-1.741	-0.602	-93	87
47	-0.154	-1.762	-0.536	-91	85
48	-0.165	-1.779	-0.471	-88	83
49	-0.171	-1.794	-0.405	-86	82
50	-0.174	-1.806	-0.349	-84	82
51	-0.175	-1.816	-0.292	-82	81
52	-0.173	-1.824	-0.237	-80	81
53	-0.169	-1.831	-0.185	-78	82
54	-0.164	-1.836	-0.135	-76	82
55	-0.158	-1.839	-0.088	-75	83
56	-0.151	-1.841	-0.043	-73	84
57	-0.145	-1.842	0.001	-72	85
58	-0.138	-1.842	0.044	-72	87
59	-0.132	-1.841	0.085	-72	88
60	-0.127	-1.839	0.126	-72	90
61	-0.121	-1.836	0.168	-72	91
62	-0.116	-1.832	0.209	-73	92
63	-0.111	-1.827	0.252	-74	93
64	-0.106	-1.821	0.296	-75	94
65	-0.099	-1.813	0.341	-77	95
66	-0.092	-1.804	0.388	-78	95
67	-0.084	-1.793	0.437	-80	95
68	-0.073	-1.781	0.488	-82	95
69	-0.060	-1.766	0.541	-84	94
70	-0.044	-1.745	0.595	-86	93
71	-0.024	-1.729	0.650	-88	92

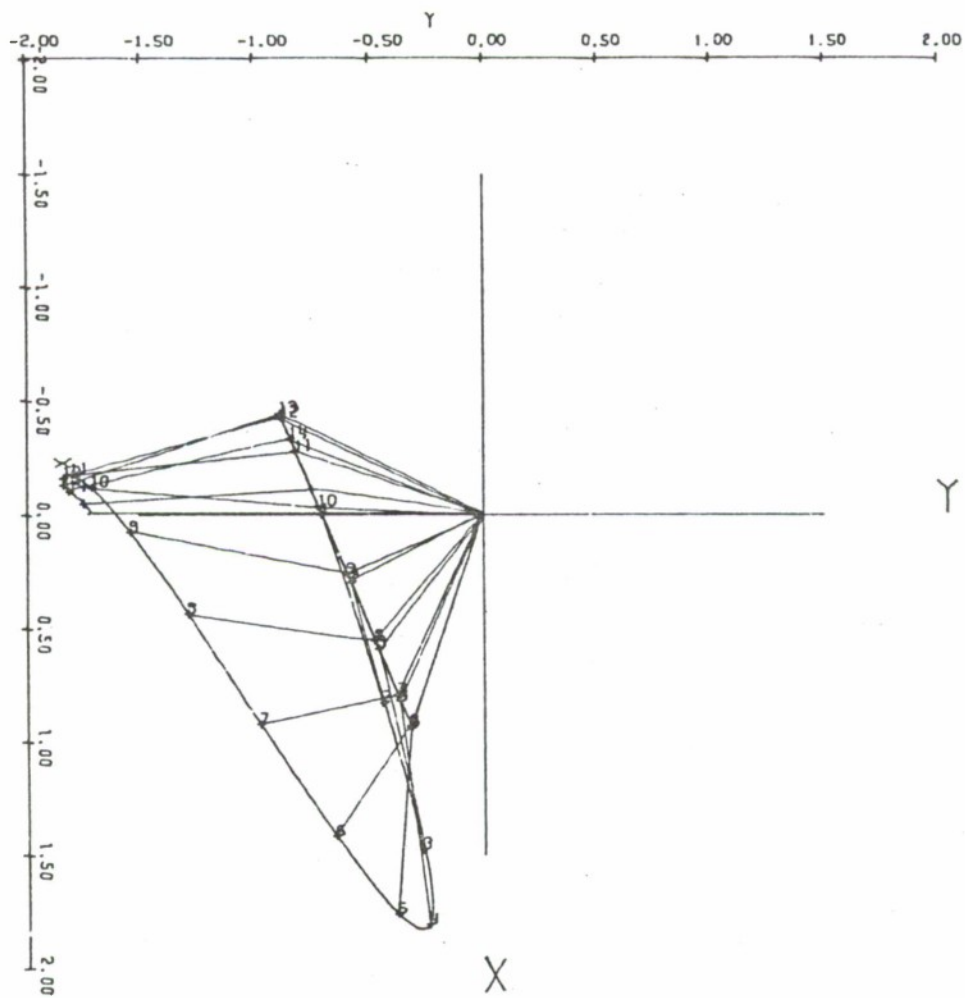

Figure 10a. Normal line density with axis (X-Y projection).

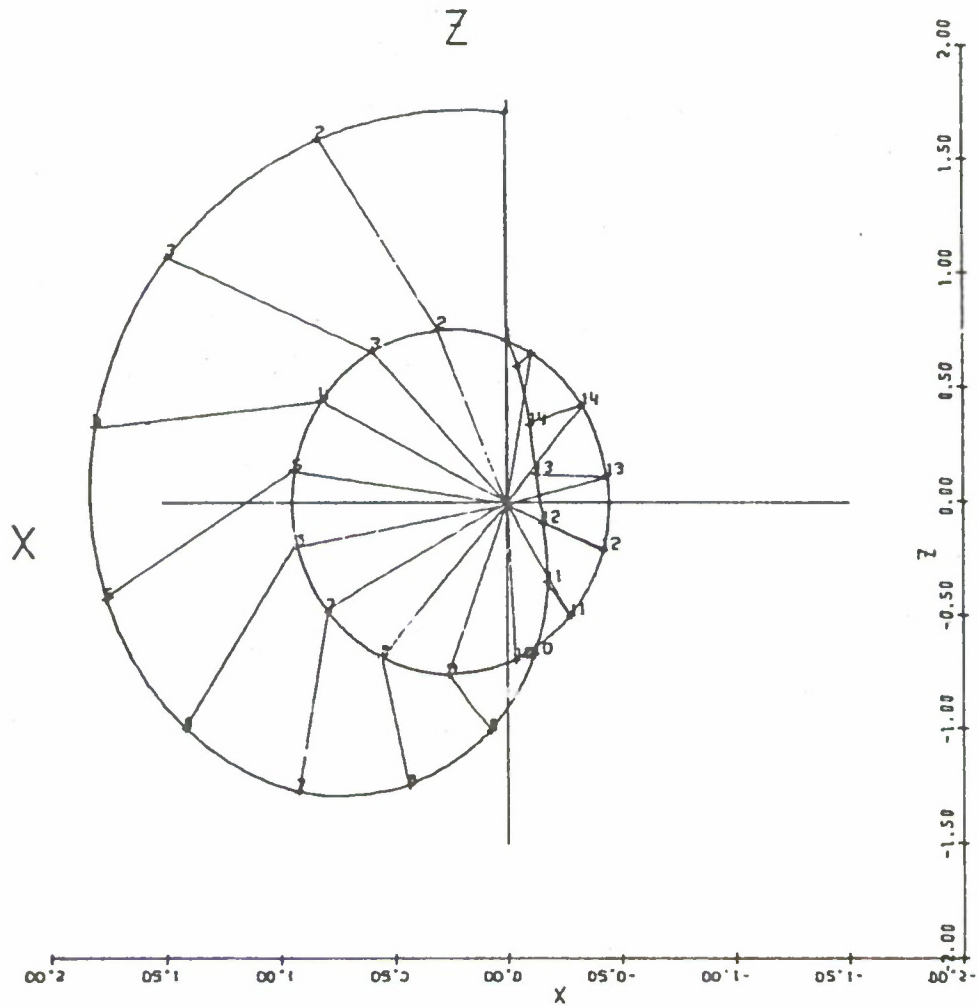

Figure 10b. Normal line density with axis (X-Z projection).

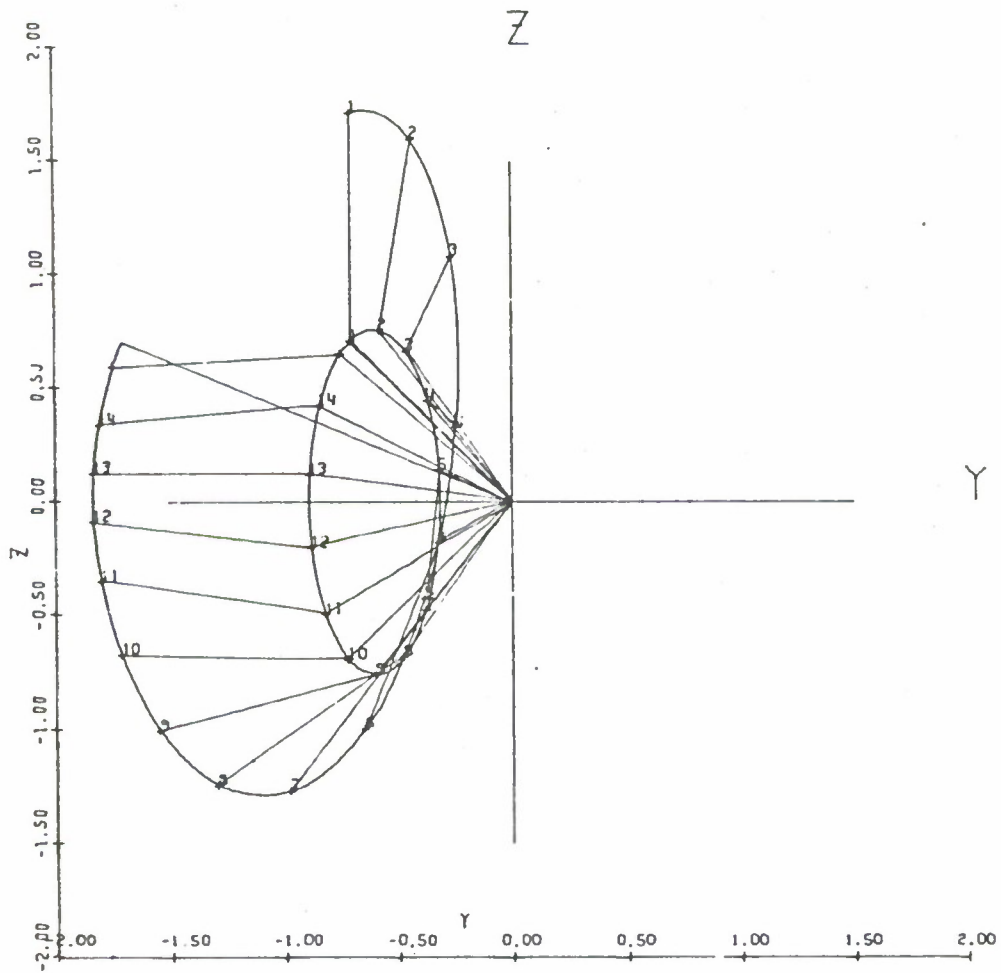

Figure 10c. Normal line density with axis (Y-Z projection).

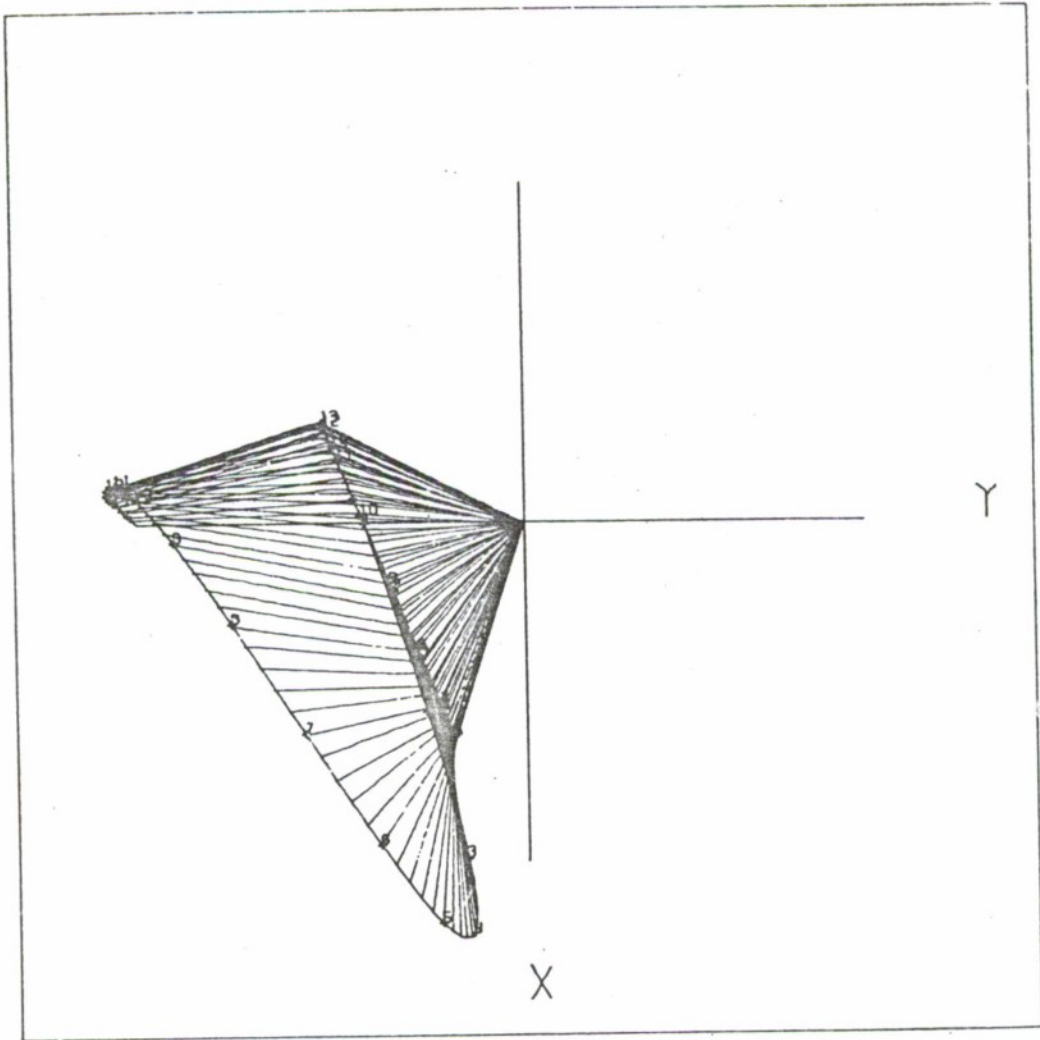

Figure 11a. Maximum line density (X-Y projection).

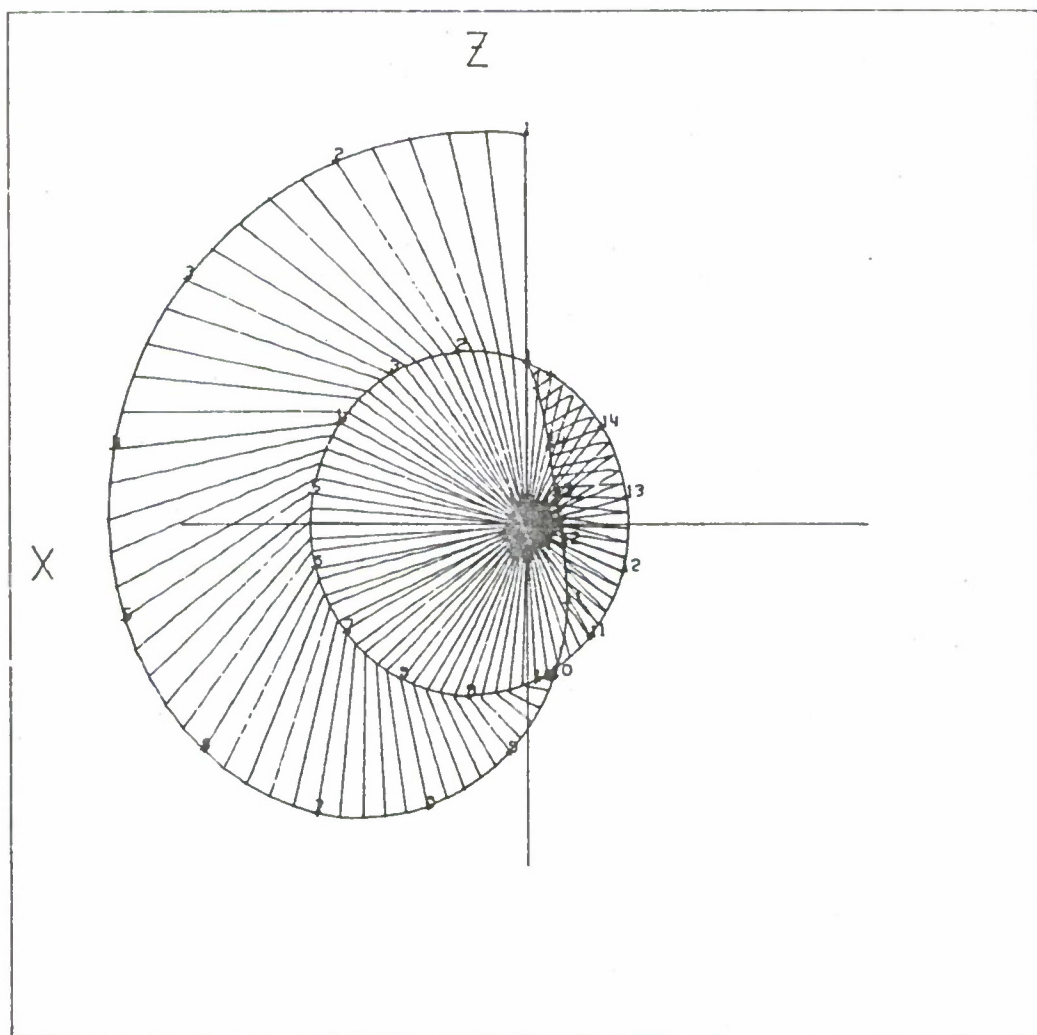

Figure 11b. Maximum line density (X-Z projection).

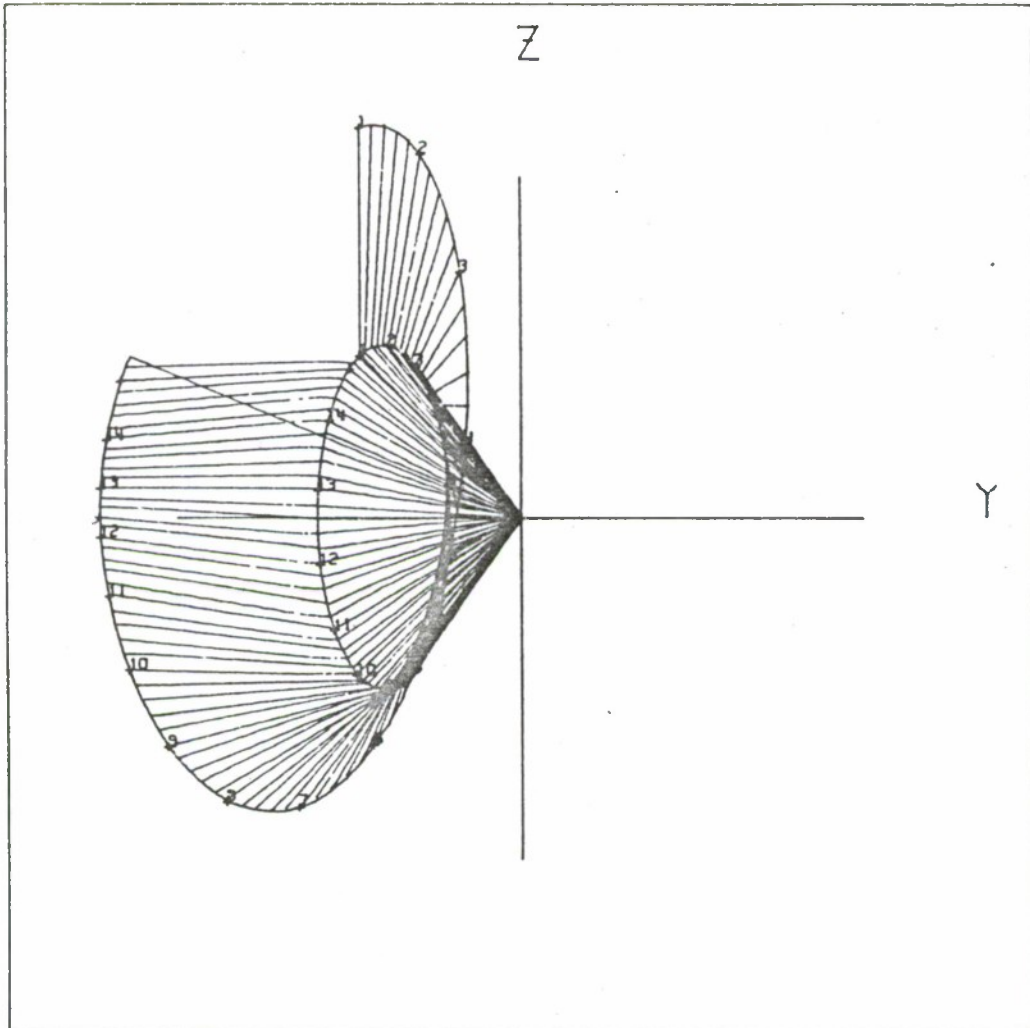

Figure 11c. Maximum line density (Y-Z projection).

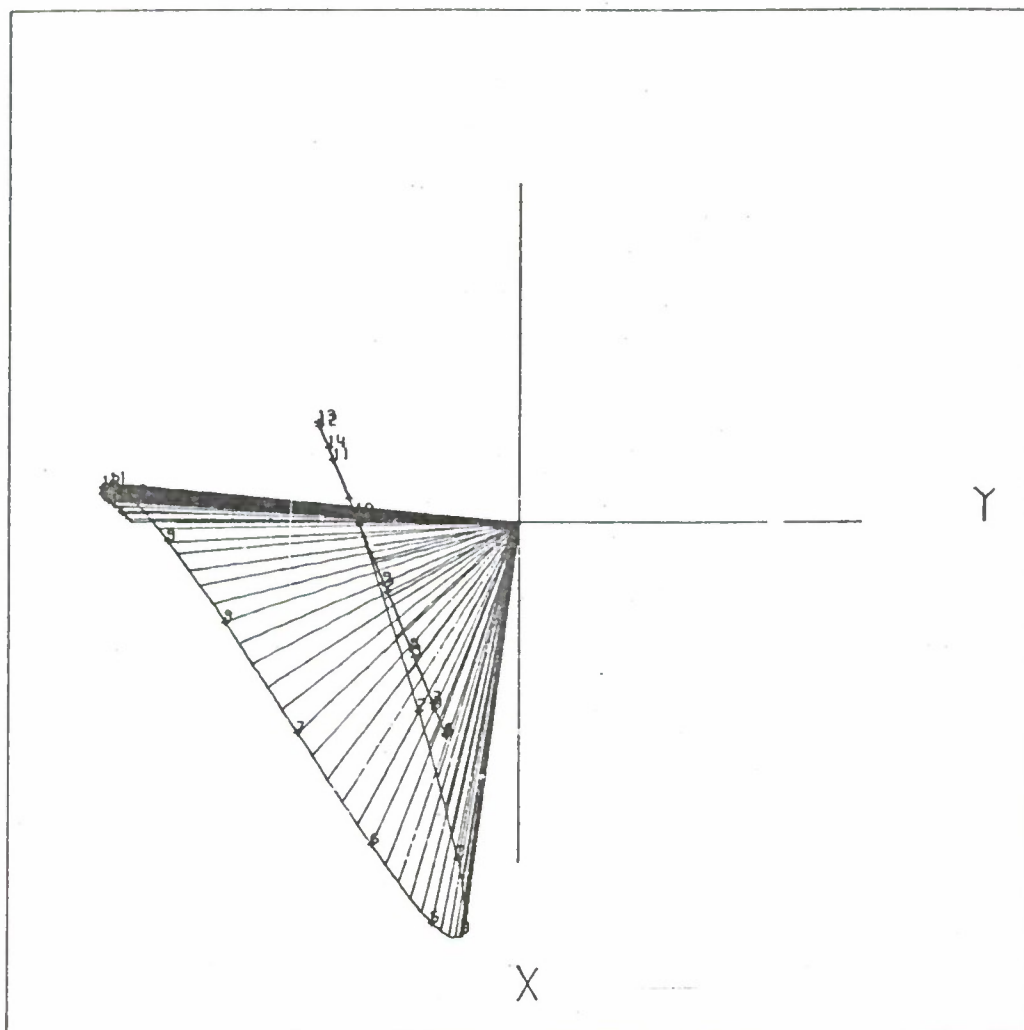

Figure 12a. Maximum line density and outermost trajectories joined to center (X-Y projection).

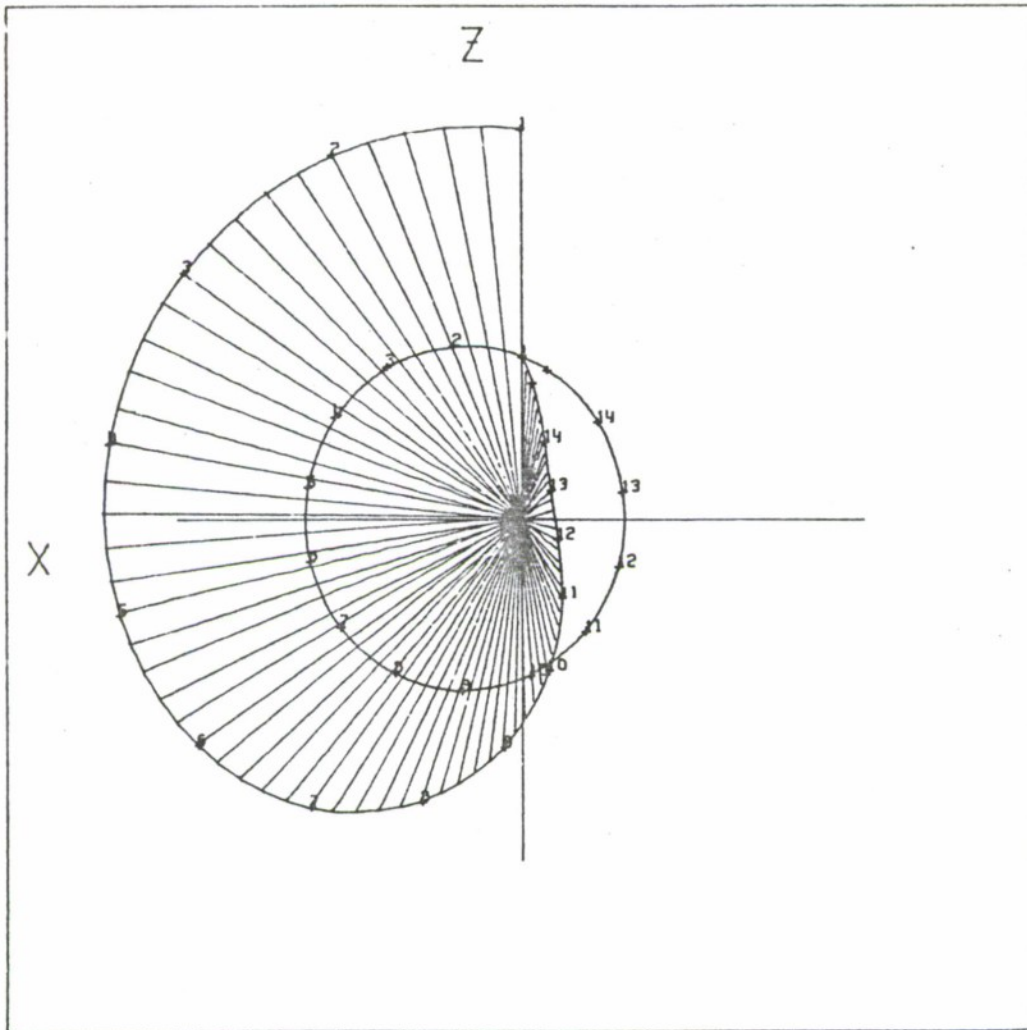

Figure 12b. Maximum line density and outermost trajectories joined to center (X-Z projection).

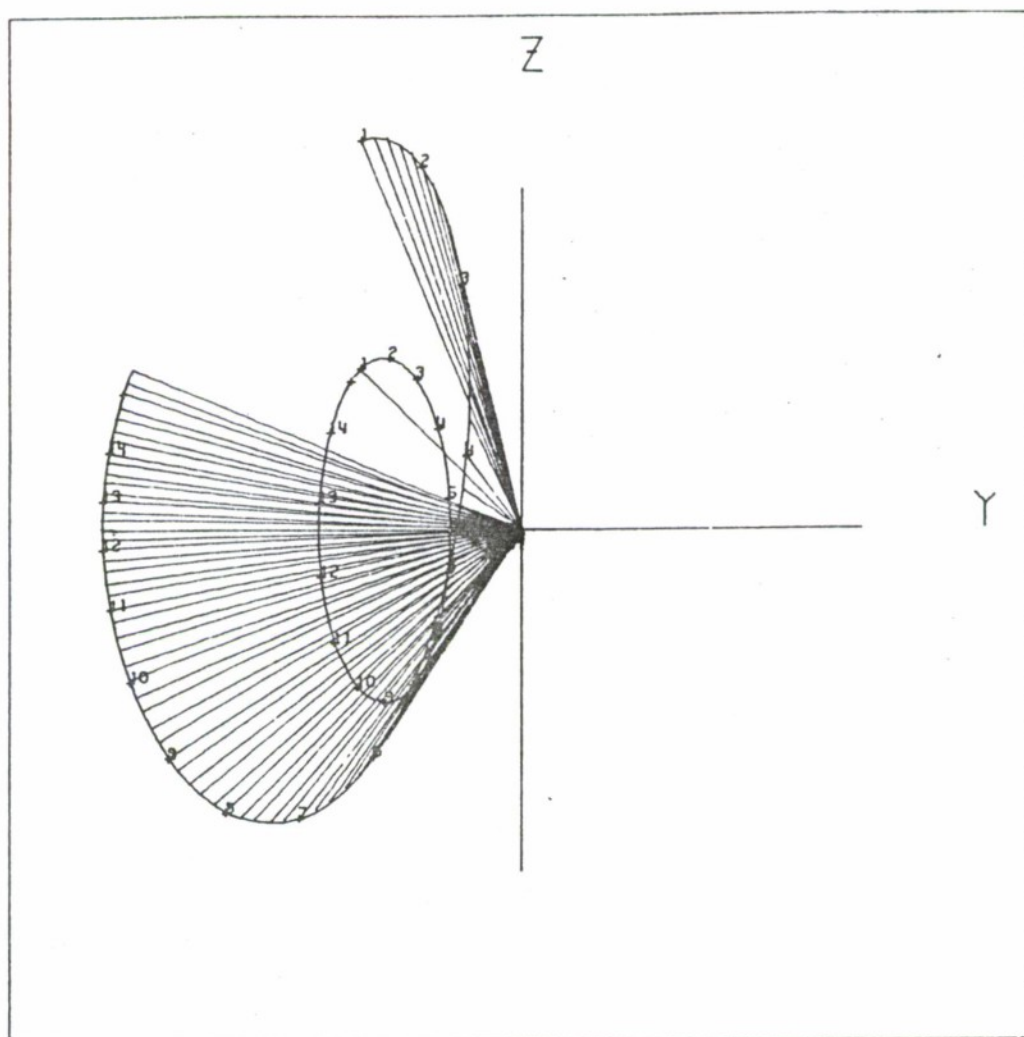

Figure 12c. Maximum line density and outermost trajectories joined to center (Y-Z projection).

case of the first limb, or the extremity of the previous limb in the case of other limbs. The direction is given in spherical coordinates, as indicated earlier. A flowchart and listing of DANCER are included in the appendix.

A routine checking for intersection of limbs was included in an earlier version of DANCER. This feature was found to be of little value and very time consuming and was consequently removed in later versions.

IV. A MODEL OF THE HUMAN BODY: STKMAN

The first step in constructing a model of the human body is to decide on how the body is to be described. It was decided to use a system of rigid limbs as in the E-W notation (see Figure 2). When constructing a coordinate system to describe such a model, with so many parts, it is essential to adopt a mathematical notation which is both flexible and easily manipulated. The first problem in such a construction is to adopt an ordering of the limbs which was done as in Figure 13. The body is considered as being made up of five limb sequences of four limbs each. The pelvis and lower back are considered as being made up of three limbs to preserve symmetry. Next a right-handed rectangular coordinate system is considered to be rigidly embedded in each limb with the z-axis along the long axis of the limb (see Figure 13). As drawn in Figure 13, the (private) coordinate systems are embedded in the limbs so

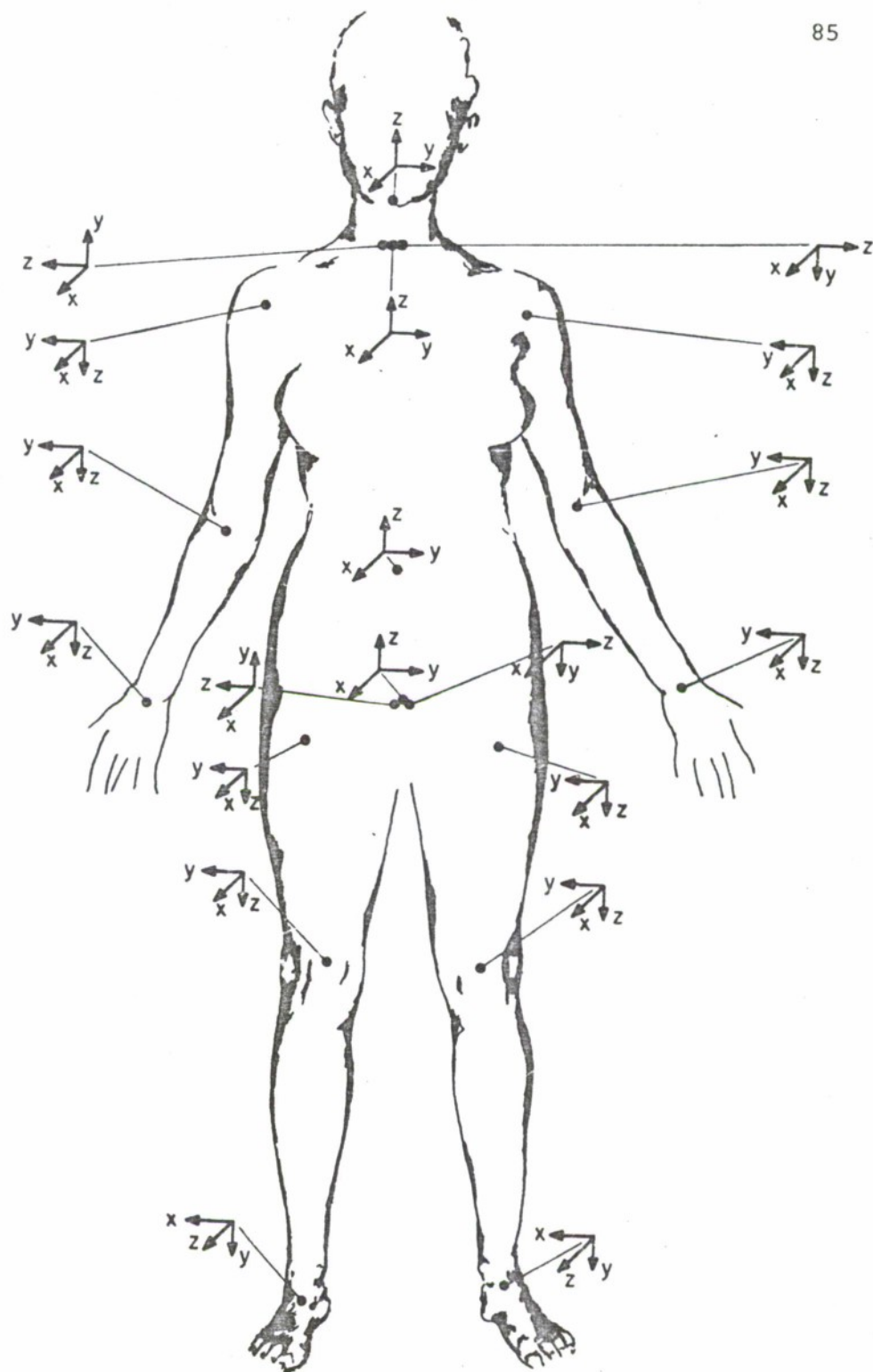

Figure 13. Private imbedded coordinate system.

that the coordinate axes are as in the zero position of the E-W notation. Since each limb is considered as a mathematically rigid body and are connected as in Figure 2, a mathematical description of the configuration of the body consists of three parts:

- 1) the position of one point in the body,
- 2) the length of each limb, and
- 3) the orientation of each limb.

It was decided to use the position of the pelvis, the first limb in the first sequence, as fundamental, i.e., its position in an external coordinate system is assumed to be given. The lengths of the limbs are contained in the 5×4 array $L_{m,n}$ ($m=1,\dots,5$, $n=1,\dots,4$) where $L_{m,n}$ is the length of the n th limb in the m th sequence of limbs.

The description of the orientation of a rigid body requires three angles. Of course, the angles may be referred to any rectangular coordinate system. The E-W notation usually uses an external coordinate system. However such a coordinate system has the disadvantage that whenever a heavy limb is moved and all of the lighter limbs do not change their relative orientation, all of the angles describing the lighter limbs change. For this reason, in STKMAN a system of angles was adopted which gives the orientation of the n th limb in terms of the coordinate system attached to the $(n-1)$ st limb. The angles describing the limb are the standard Eulerian angles (θ, ϕ, ψ) described in Goldstein's Classical

Mechanics (1950) (see Figure 14). Thus the orientation of all the limbs is given by the set of sixty angles ($\theta_{m,n}$, $\phi_{m,n}$, $\psi_{m,n}$) which is referred to as the configuration space. The angle between the z-axis of the nth limb and that of the (n-1)st limb in the mth sequence is $\theta_{m,n}$. The measurement of the other two angles requires the use of the line of nodes which is the intersection of the $(x_{m,n-1}, y_{m,n-1})$ plane with the $(x_{m,n}, y_{m,n})$ plane. $\phi_{m,n}$ is the angle between the $x_{m,n-1}$ axis and the line of nodes in the $(x_{m,n-1}, y_{m,n-1})$ plane, and $\psi_{m,n}$ is the angle between the line of nodes and the $x_{m,n}$ axis in the $(x_{m,n}, y_{m,n})$ plane. Varying $\theta_{m,n}$ rotates the nth limb about the line of nodes; varying $\phi_{m,n}$ rotates the z axis of the nth limb about the z axis of the (n-1)st limb; and varying $\psi_{m,n}$ rotates the nth limb about its own z axis. The orientation of the axes of the nth limb with

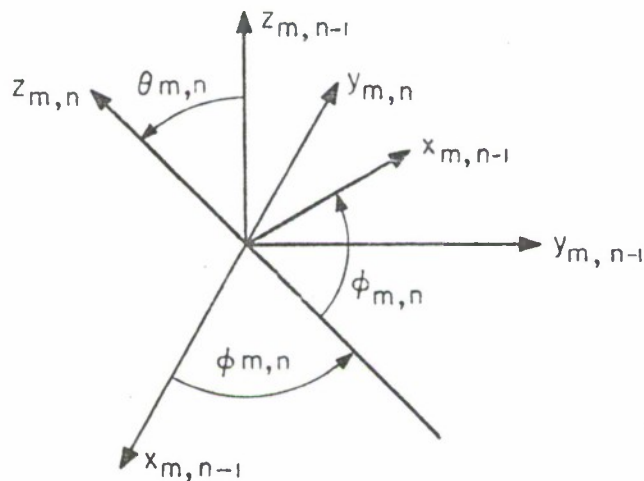

Figure 14. Eulerian angles.

respect to the axis of the (n-1)st limb is given by the columns of the matrix

$$\begin{pmatrix} \cos\psi \cos\phi & -\sin\psi \cos\phi & \sin\theta \sin\phi \\ -\cos\theta \sin\phi \sin\psi & -\cos\theta \sin\phi \cos\psi & \\ \cos\psi \sin\phi & -\sin\psi \sin\phi & -\sin\theta \cos\phi \\ +\cos\theta \cos\phi \sin\psi & +\cos\theta \cos\phi \cos\psi & \\ \sin\theta \sin\psi & \sin\theta \cos\psi & \cos\theta \end{pmatrix}$$

The first column gives the orientation of the $x_{m,n}$ axis with respect to the (m,n-1) system, the second column that of the $y_{m,n}$ axis and the third is for the $z_{m,n}$ axis. Let $a_{i,j}^{m,n}$ denote this orientation matrix, the first superscript denotes the limb sequence, $m=1, \dots, 5$, the second superscript the limb number, $n=1, \dots, 4$, the first subscript refers to the rows of the above matrix, $i=1, 2, 3$, and the second subscript the column, $j=1, 2, 3$. Thus the orientation of the $z_{m,n}$ axis relative to the (m,n-1) system is given by the three numbers $a_{i,j}^{m,n}$.

In terms of these relative angles, the zero position of the E-W notation is given by Figure 15. The circled angles are constrained to be as given to correspond to the two degrees of freedom in some joints. In addition since the pelvis is rigid, the following constraints are also imposed:

$$\begin{aligned} \theta_{2,1} &= 90^\circ + \theta_{1,1}, & \phi_{2,1} &= \phi_{1,1}, & \psi_{2,1} &= \psi_{1,1} \\ \theta_{3,1} &= 90^\circ + \theta_{1,1}, & \phi_{3,1} &= 180^\circ + \phi_{1,1}, & \psi_{3,1} &= 180^\circ + \psi_{1,1}. \end{aligned}$$

The description of the model becomes complete when it is stated how any position of the body can be computed given

Limb sequence	Limb	θ	ϕ	ψ
1	1	0	0	0
	2	0	0	0
	3	0	0	0
	4	0	0	0
2	1	90°	0	0
	2	90°	0	0
	3	0	270°	90°
	4	90°	90°	0
3	1	90°	180°	180°
	2	90°	180°	180°
	3	0	270°	90°
	4	90°	90°	0
4	1	90°	0	0
	2	90°	0	0
	3	0	90°	270°
	4	0	0	0
5	1	90°	180°	180°
	2	90°	180°	180°
	3	0	90°	270°
	4	0	0	0

Figure 15. Zero position.

the position of the pelvis $(X, Y, Z) = X_i$, the lengths of the limbs $L_{m,n}$ and the configuration space $(\theta_{m,n}, \phi_{m,n}, \psi_{m,n})$ which is now done. This is simply a matter of vector addition. From the following example, the reader should see how the process is carried out in general: suppose the position of the tip of the left hand is to be computed. The position of the pelvis is X_i , the orientation of the pelvis is given by the matrix $a_{i,j}^{1,1}$ so the position of the top of the pelvis is

$$x_i^2 = L_{1,1} a_{i,3}^{1,1}.$$

The orientation of the chest relative to the pelvis is $a_{i,j}^{1,2}$, so the orientation of the chest relative to the external coordinate system is given by the matrix product $A_{i,j}^{1,2}$ where

$$A_{i,j}^{1,2} = a_{i,n}^{1,1} a_{n,j}^{1,2}$$

and the summation convention is used. Thus, the position of the top of the chest is

$$x_i^2 = x_i^1 + L_{1,2} A_{i,3}^{1,2}.$$

Continuing in this manner the position of the left finger tips is, (c.f., Figure 2),

$$\begin{aligned} X_i = & L_{1,1} a_{i,3}^{1,1} + L_{1,2} A_{i,3}^{1,2} + L_{4,1} A_{i,3}^{4,1} + L_{4,2} A_{i,3}^{4,2} \\ & + L_{4,3} A_{i,3}^{4,3} + L_{4,4} A_{i,3}^{4,4}. \end{aligned}$$

where the orientation matrices relative to the exterior coordinate system are found as

$$A_{i,j}^{4,1} = A_{i,k}^{1,2} a_{k,j}^{4,1}; \quad A_{i,j}^{4,2} = A_{i,n}^{4,1} a_{n,j}^{4,2}; \quad \text{etc.}$$

Thus, a computation algorithm for finding the position of any point in the body is obtained. A subroutine was written to compute and plot the limbs of the body given the position of the pelvis, the length of the limbs and the configuration space. The program was then tested for various positions (see plots, pp. 163-167).

With the completion of this subroutine called PØSIT (for position), it becomes possible to compute the motions of the body by giving the position of the pelvis and the configuration space as functions of time. This was done for two relatively simple motions, 1) bending over and swinging arms, and 2) walking. Finding the angles as functions of time for (1) was relatively simple and is not described here. The second motion was more difficult and is described in detail here.

The essential property of a person walking is propelling the body along at a constant velocity. For STKMAN this amounts to giving the pelvis a constant velocity and then moving the legs in such a manner that it appears the legs are causing movement. The minimum number of angles are used (see Figure 16), and no rotation of the legs is allowed, only bending, and the foot is held parallel to the floor. The reader may verify that if bending at the hip, knee and ankle in the forward direction are the only motions used, then the

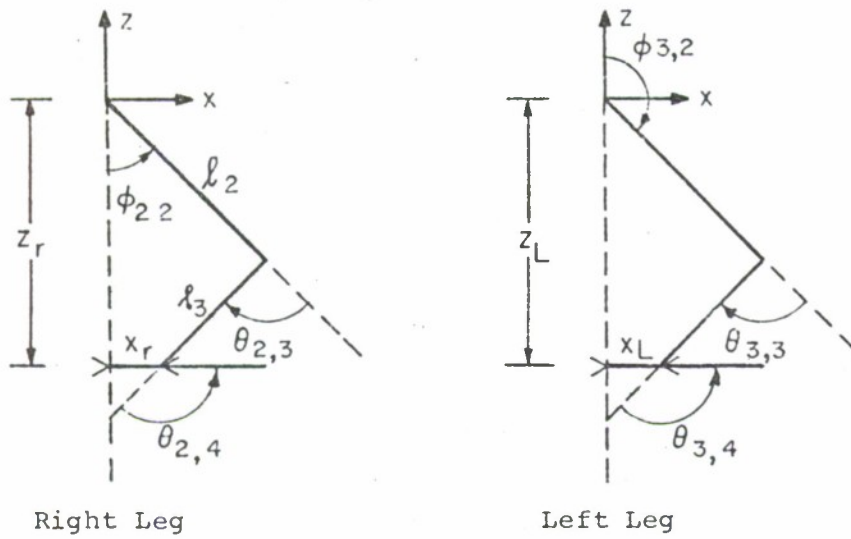

Figure 16. Abstraction of a bending leg.

only angles varied from zero position are those indicated in Figure 15. From the figure it follows that

$$z_r = l_2 \cos \phi_{22} + l_3 \cos(\theta_{23} - \phi_{22}),$$

$$x_r = l_2 \sin \phi_{22} - l_3 \sin(\theta_{23} - \phi_{22}),$$

$$z_r = l_2 \cos(180^\circ - \phi_{32}) + l_3 \cos[\theta_{33} - (180^\circ - \phi_{32})],$$

$$x_r = l_2 \sin(180^\circ - \phi_{32}) - l_3 \sin[\theta_{33} - (180^\circ - \phi_{32})].$$

The condition that the feet remain parallel to the floor is

$$\theta_{24} = 90^\circ + \theta_{23} - \phi_{22},$$

$$\theta_{34} = \phi_{32} + \theta_{33} - 90^\circ.$$

A walking routine is obtained by giving $z_r(t)$, $x_r(t)$, $z_r(t)$ and $x_r(t)$ as the appropriate functions of time. The angles

as functions of time are found by solving the above equations, for example,

$$\cos\theta_{23} = \frac{x_r^2 + z_r^2 - (l_2^2 + l_3^2)}{2l_2l_3}$$

$$\tan\phi_{22} = \frac{x_r(l_2 + l_3 \cos\theta_{23}) + z_r l_3 \sin\theta_{23}}{z_r(l_2 + l_3 \cos\theta_{23}) - x_r l_3 \sin\theta_{23}}$$

A program was written to compute and plot the position of STKMAN for various assumptions about the time variations of x_r , z_r , x_n , z_n . (See listing and plots.)

It was also attempted to write a program to translate the E-W notation into the relative angles of STKMAN, but it was found that this was not possible without further consultation for two reasons. First, the E-W notation refers the orientation of limbs to an exterior coordinate system only when the limb is moving, otherwise the previous orientation is maintained. This causes no difficulty for a person reading the notation, but it proves to be rather difficult to program. The second problem was the way that the notation of a limb about its own axis is treated in the E-W notation. As we understand, the rotational state of a limb is given by the azimuth of the projection of the normal (the x-axis of the limb) to the limb upon the (x,y)-plane. For certain orientations this specification is simply not unique. For example, if z axis of the limb is oriented along the x axis, then the E-W notation cannot specify the direction of the

normal to the limb which may lie anywhere in the (x,z) plane. This difficulty may be overcome by specifying the normal by two polar angles, or by one Eulerian rotation angle.

Further work on STKMAN is possible. In particular it would be interesting to use this model to obtain plots of more complex motions, such as various dances. This of course would require much more work to obtain the angles as functions of time. It would also be interesting to do the inverse problem of given a particular motion of the body (i.e., the position of various limbs of the body as functions of time) find the corresponding angles. The problem of the dynamical motion of the body remains to be done. The equations of motion must be obtained by the rather difficult problem of referring the gyroscopic equations of motion to an arbitrary moving coordinate system.

V. CONCLUSION

Although both DANCER and STKMAN are basically position oriented notational programs, it is possible to input subroutines to STKMAN which in fact control movement as in the WALK subroutine. It is a simple matter to make STKMAN accept goal type commands of the sort "walk to such or such a place" by computing internally in the program the length of the steps to take, the direction to be taken, etc. It would be terribly cumbersome, however, to program each possible type of human movement in this manner. The program would soon

reach an extremely large size without any guarantee of exhausting possible movements. Optimization is here a key problem, and seems to be a logical next area of investigation.

Other problems remain. Limbs of a simulator behaving like human limbs would be subject to dynamic constraints, which, as pointed out earlier, lead to difficult equations of motion. Forbidden regions of movement caused by joint structure could be determined by a table hookup system in STKMAN (see Prost, 1967 and Figure 17), but these interdictions would not be reflected in the notation. A more refined notation could solve both the dynamic and range problems, by specifying syntactic rules forbidding impossible movements and taking into account the physical characteristics of the limbs being moved.

The problem of defining such a complete notation reduces most easily to that of determining proper input to a finite state or context sensitive automaton which would simulate movements of the body. Although STKMAN is such an automaton, it is hardly discriminating enough in the input it accepts: it could, however, be adapted to accept more rigorous input. As an example, the WALK subroutine can be approximated by the automaton of Figure 18. This automaton will accept the alphabet

S = start

L = left leg moves forward

R = right leg moves forward

E = movement stops

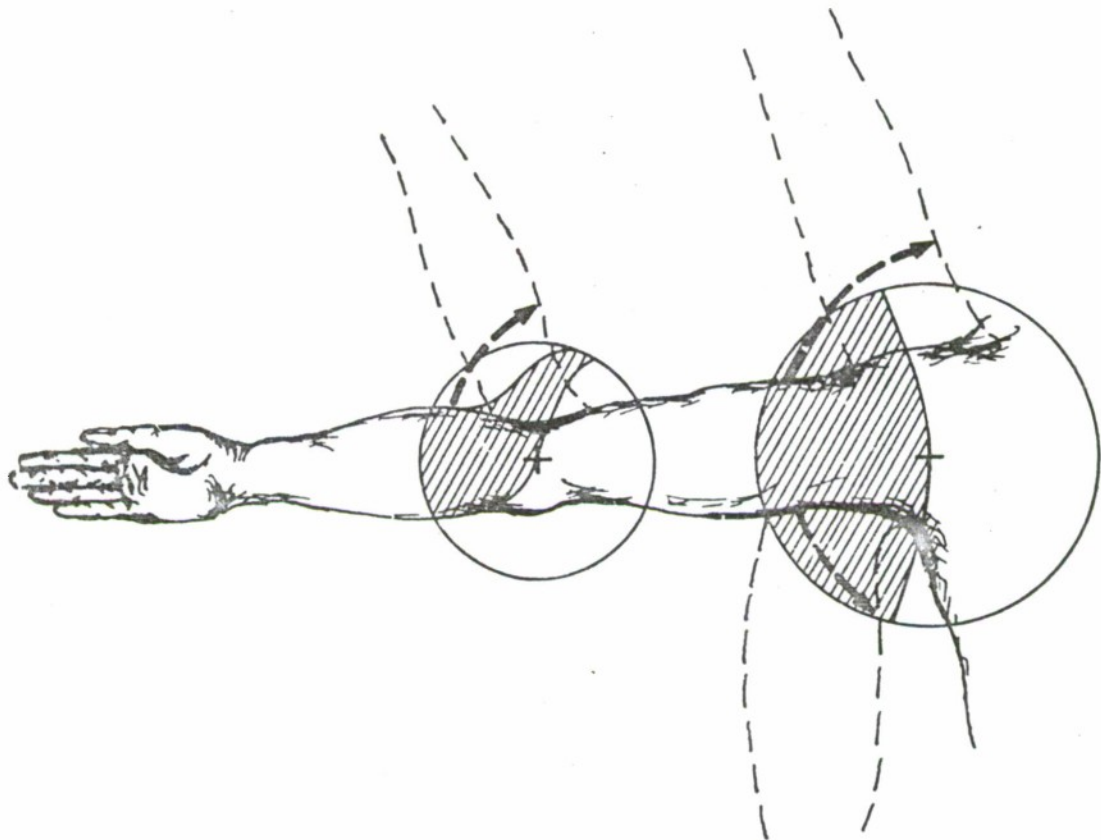

Figure 17. Ranges of allowable movement in shoulder and elbow.

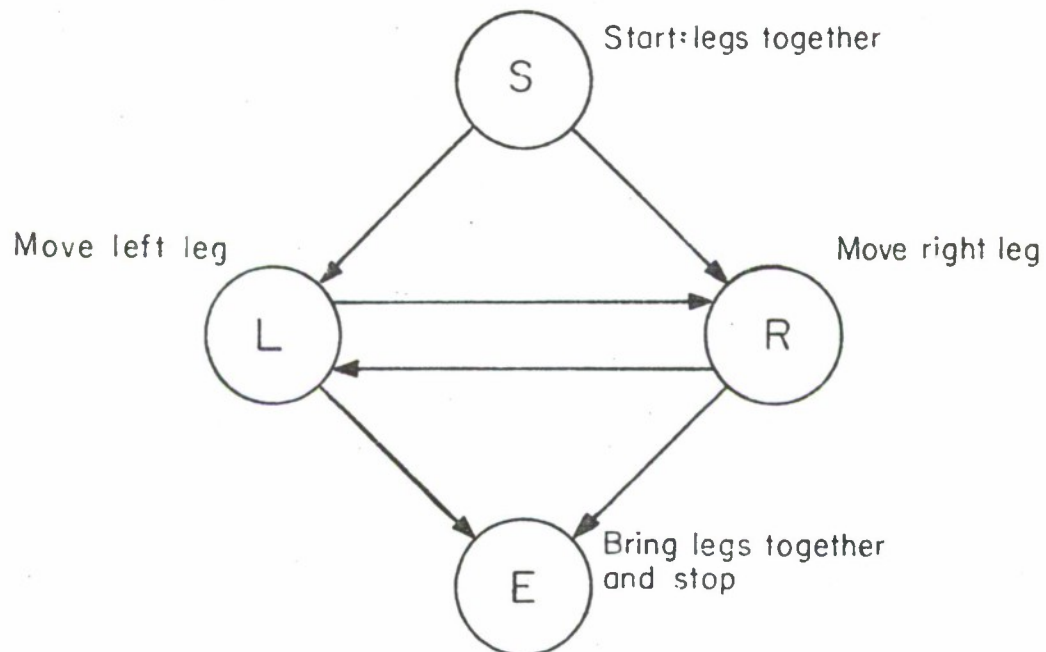

Figure 18. Simple automaton accepting walking commands.

It is easily verified that the string SLRLRE is acceptable while the string SLLE is not. The grammar generated is then

1. $S \rightarrow RS_R \mid LS_L$
2. $S_R \rightarrow LS \mid E$
3. $S_L \rightarrow RS \mid E$

- (1. Starting can only lead to moving the right or left leg.
2. After the right leg has been moved, one can only move the left leg or stop.
3. After the left leg has been moved, one can only move the right leg or stop.)

Such grammars could possibly be extended to include more complex sequences of movements and seem most promising for establishing a complete movement notation based on the E-W notation.

REFERENCES

1. Denier van der Gon, J. J. and J. Ph. Thuring, "The Guiding of Human Writing Movements," *Kybernetik*, 2 (4), 145-148 (1965).
2. Denier van der Gon, J. J., J. Ph. Thuring and J. Strackee, "A Handwriting Simulator," *Physics in Medicine and Biology*, 6 (3), 407-414 (1962).
3. Goldstein, H., *Classical Mechanics*, Addison-Wesley Publishing Company, Inc., Reading, Massachusetts, 399 pp. (1950).
4. Prost, J. H., "Bipedalism of Man and Gibbon Compared Using Estimates of Joint Motion," *American Journal of Physical Anthropology*, 26 (2), 135-148 (1967).

APPENDICES

APPENDIX Ia. FLOWCHART OF DANCER

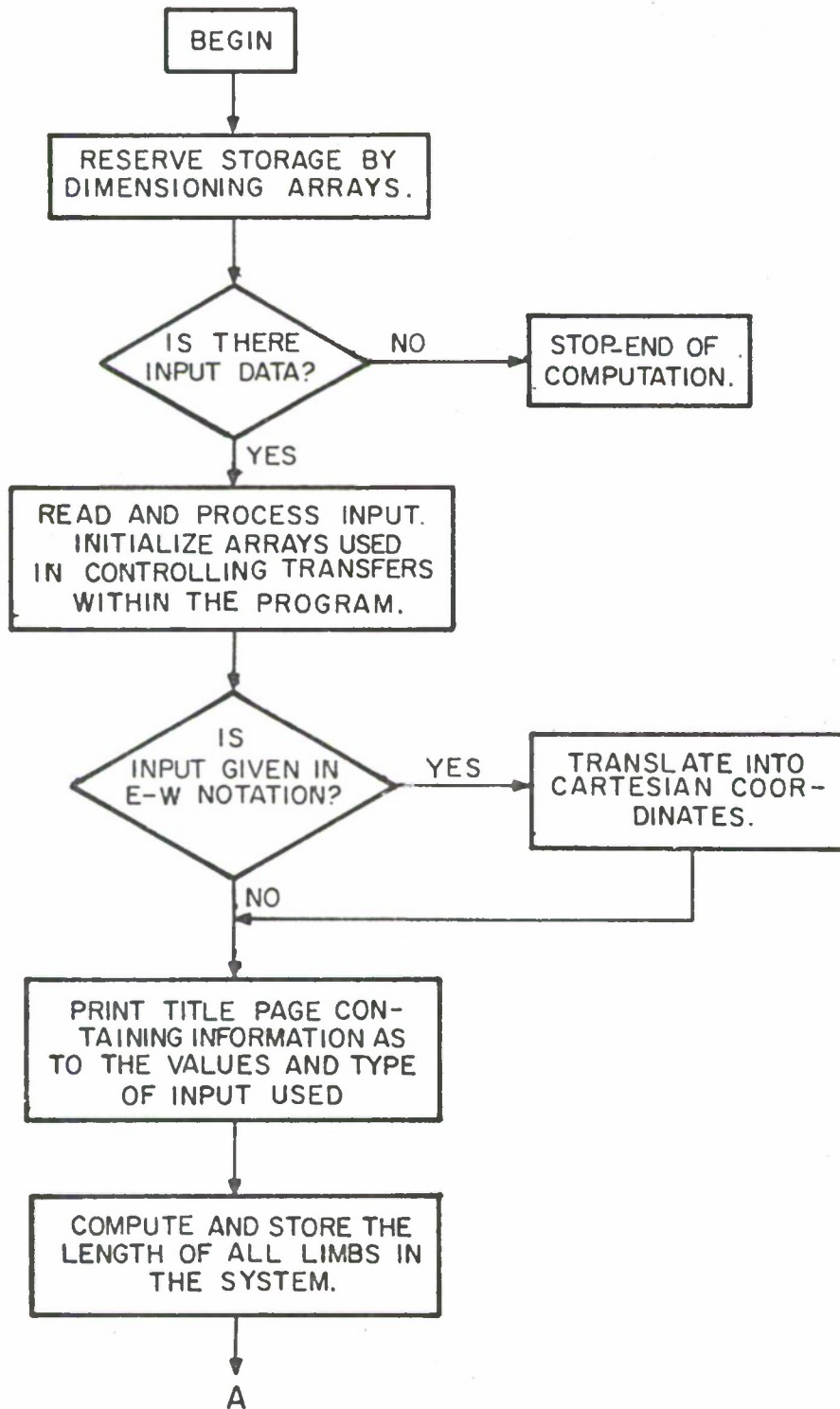

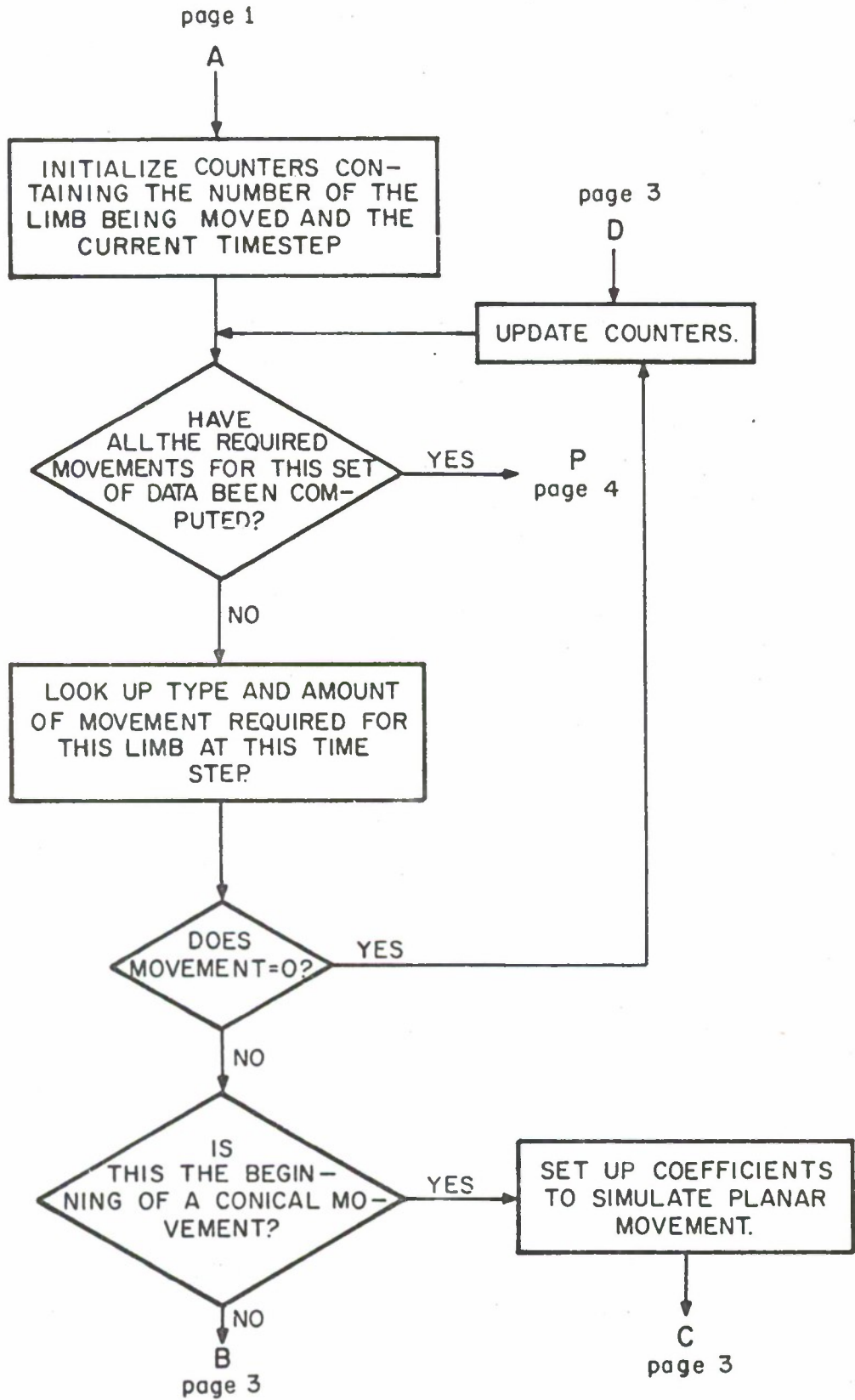

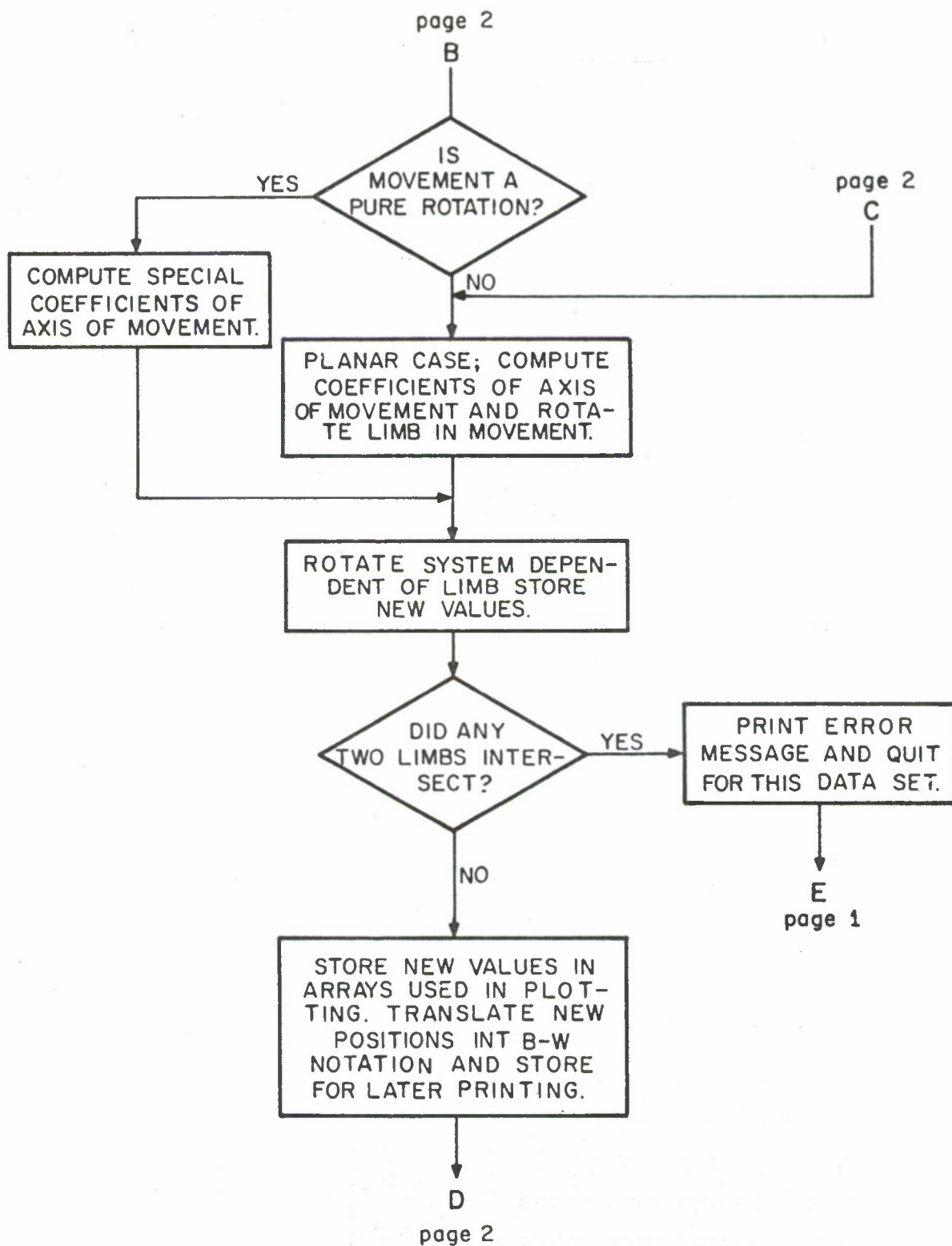

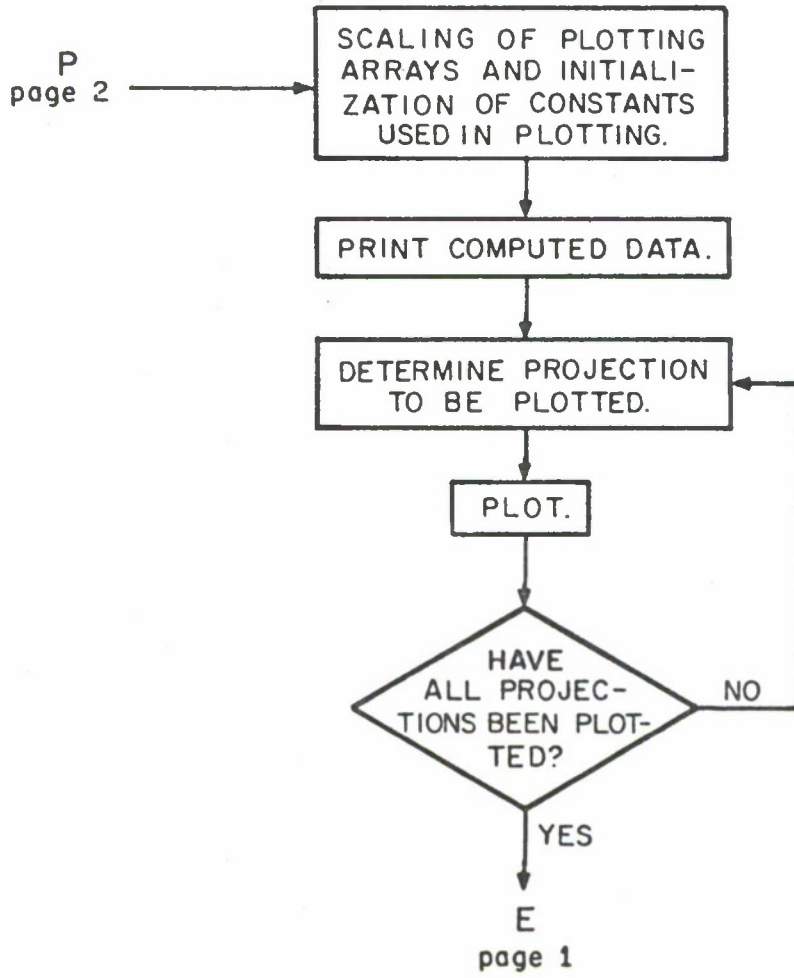

APPENDIX Ib. PROGRAM LISTING OF DANCER

```

0001 IMPLICIT REAL*8(A-H,O-Z)
0002 REAL*4 CR1,CR2,CR3,TS,IX,IY,IZ,XLIN,XLJN,YLIN,YLJN
0003 REAL*4 XPLI,YPLI,ZPLI,FR,XTRACE,YTRACE,ZTRACE,ISA
0004 REAL*4 SIGX,SIGY,SIGZ,TH,ALX,ALY
0005 DIMENSION KSPCOU(10),KCCNTR (10,10,2)
0006 DIMENSION PLOT(5,150,3),XPLI(I52),YPLI(I52),ZPLI(I52),ALONG(11)
      1 ,XTRACE(11),YTRACE(11),ZTRACE(11),FR(3)
0007 DIMENSION IPECS(11,152,2)
0008 DIMENSION KNGAR(11,10)
0009 DIMENSION ROTR(10,200)
0010 DIMENSION IX(2),IY(2),IZ(2),IS(2),ISA(2)
0011 DIMENSION ARRAY(11,6),TSTEP(11),AMOV(11),KTYP(11)
0012 DIMENSION XLIN(2),YLIN(2),XLJN(2),YLJN(2)
0013 DIMENSION ORI(3),OR2(3),OR3(3)
0014 DIMENSION AINTER(10,20,3), LCOUNT(10)
0015 DIMENSION ANGLE(IC,200),ITYPE(10,200)
0016 DIMENSION AD(11),CLONG(11) ,ISTCP(11)
0017 DIMENSION TEMM(2,11,3)
0018 DIMENSION SIGX(500),SIGY(500),SIGZ(500)
0019 DIMENSION ALX(5),ALY(5)
0020 DIMENSION TM(2)
0021 FORMAT(3F10.5,110)
0022 3 FORMAT(5I5)
0023 4 FORMAT(3I5,3F10.5)
0024 5 FCRMAT(3F10.5)
0025 6 FCRMAT(15)
0026 8 FCRMAT(45X,24H THE UNIT ANGLE EQUALS ,15)
0027 11 FCRMAT(45X,34H E-W NOTATION WAS USED FOR INPUT )
0028 12 FCRMAT(45X,51H RECTANGULAR COORDINATE VALUES WERE USED FOR INPUT
      1 )
0029 13 FCRMAT(45X,21H THIS SYSTEM CONTAINS ,13,6H LIMBS //)
0030 14 FCRMAT(//756X,6H UP 10,718X,13H LIMB JOINTS ,32X,20H INTERMEDIARY
      1 POINTS,12),1CH ITERATION,1X,6H TYPE ,4H MOV )
0031 15 FCRMAT(45X,7F EVERY ,13,26H POINTS WILL BE CONNECTED )
0032 16 FCRMAT(1H1,///,50),24H ***** /,52X,21H *TABLE
      1CF RESULTS * //)
0033 17 FORMAT(45X,5CH ONLY THE LIGHTEST LIMB WILL BE JOINED TO CENTER )

```

```

0034      FURMAT(3E32.16)
0035      FURMAT(/18H UNITY IS EQUAL TO ,F10.5)
0036      FURMAT(9X,2H X,8X,2H Y,8X,2H Z,6X,5H HORI,6H VERT )
0037      FURMAT(14,3F10.3,3X,216 )
0038      FURMAT(1H1,30H COORDINATES OF LIMB NUMBER ,14/)
0039      FURMAT(10F TRCVLE )
0040      FURMAT(10H TROUBLE )
0041      FURMAT(1H1,32H WRCNG TYPE CF MOVEMENT FOR LIMB ,15)
0042      FURMAT(48X,3F16.4,17,16,15)
0043      FURMAT(3F16.4)
0044      FURMAT(2115,2X,F16.4)
0045      FURMAT(48X,2115,2X,F16.4,17,16,15)
0046      FURMAT(5CX,3F10.4)
0047      FURMAT(60X,3F10.4)
0048      FURMAT(1H1,39H NO INTERMEDIARY POINT GIVEN FOR LIMB ,13)
          CCCCCCCCCCCCCCCCCCCCCCCCCCCCCCCCCCCCCCCCCCCCCCCCCC
          C
          C
0049      PI = 3.141592653589793
0050      19 KI=C
0051      KSW=C
0052      KTYPC=9
0053      KC=1
0054      KWCR = 1
0055      KSIG=0
0056      CC 729 KC=1,10
0057      CC 725 KR=1,200
0058      ITYPE(KQ,KR)=C.0
0059      729 CCNTINUE
          C
          C

```

C CONTROL SECTION FOR READING IN OF INPUT

```

0060 705 READ(5,3) NOT,KVIEW,KANGLE,LSPACE,KAXIS
0061 IF(KVIEW.EQ.99) GO TO 4500
0062 READ(5,2) (ARRAY(KC,LLL),LLL=1,3),LCHECK
0063 IF(LCHECK.EQ.99) GO TO 22
0064 ICCUNT=1
0065 KCLD=1
0066 READ(5,4) KSTEP,LTYPE,MOTOT,(AINTER(KC,ICOUNT,LLL),LLL=1,3)
0067 IF(KSTEP.EQ.0) GO TO 709
0068 IF(LTYPE.GT.5) GO TO 4503
0069 KRCTA=0
0070 IF(LTYPE.NE.4.AND.LTYPE.NE.5) GO TO 706
0071 READ(5,6)KRCTA
0072 CCNTINUE
0073 KCCNTR (KC,ICOUNT,1)=KSTEP
0074 KCCNTR (KC,ICOUNT,2)=LTYPE
0075 KNGAR(KC,ICOUNT)=MOTOT
0076 ICCUNT=ICCUNT+1
0077 TEMPI=MOTOT
0078 TEMPI=TEMPI/KSTEP
0079 TEMPI=TEMPI*(PI/180.)
0080 TEMP2=KRCTA
0081 TEMP2=(TEMP2/KSTEP)*(PI/180.)
0082 GO TO 701 K=KCLD,KSTEP
0083 ITYPE(KC,K)=LTYPE
0084 RCTR(KC,K)=TEMP2
0085 ANGLE(KC,K)=TEMPI
0086 KOLD=KSTEP+1
0087 GO TO 708
0088 ISTEP(KC)=KCLD-1
0089 IF(ICOUNT.EQ.1) GO TO 4502
0090 KSPCCU(KC)=ICCUNT-1
0091 LCCUNT(KC)=2
0092 ARRAY(KC,4) = AINTER(KC,1,1)
0093 ARRAY(KC,5) = AINTER(KC,1,2)
0094 ARRAY(KC,6) = AINTER(KC,1,3)

```

```

0095      KC=KC+1
0096      GO TO 7C7
C
C      AND INITIALIZATION OF ARRAYS USED IN PLOTTING THE ORIGIN OF SYSTEM
C
0097      22      AN=KC-1
0098      CC 8CO MM=1,102
0099      XPLI(MM) = 0.
0100      YPLI(MM) = 0.
0101      ZPLI(MM) = C.
0102      ECC      CCNTINUE
0103      CR1(I) = ARRAY(1,1)
0104      CR2(I) = ARRAY(1,2)
0105      CR3(I) = ARRAY(1,3)
C
C
C      PRINTING CF TITLES
C
0106      WRITE(6,16)
0107      WRITE(6,13) AN
0108      IF(LSPACE.EC.0) LSPACE=5
0109      WRITE(6,15) LSPACE
0110      IF(LSPACE.GE.0) GO TO 536
0111      WRITE(6,17)
0112      536      CCNTINUE
C
C
C      (CCORDINATE TRANSLATION FOR E/W NOTATION
C      AND PRINTING CF VALUES AT BEGINNING OF COMPUTATION
C
0113      IF(NCT.NE.1) GO TO 25
0114      WRITE(6,11)
0115      WRITE(6,8) KANGLE
0116      CC 543 KPL=1,NN
0117      543      CCNTINUE
0118      WRITE(6,14)
0119      WRITE(6,892) CR1(1),CR2(1),CR3(1)
0120      CO 544 KK=1,NN
0121      KTEMP=KSPCCU(KK)
0122      CC 545 KL=1,KTEMP
0123      KFCC=AINTER(KK,KL,1)+0.1
0124      LFCC=AINTER(KK,KL,2)+0.1
0125      R = AINTER(KK,KL,3)

```



```

C
C      COMPUTATION OF THE POSITION OF THE FIRST POINT IN SPHERICAL
C      COORDINATES AND STORING OF THE INFORMATION IN THE ARRAY 'IPECS'
C      LSEC FOR OUTPUT PRINTING
0158      DO 588 KSP=1,NN
0159          PLCT(KSP,1,1) = ARRAY(KSP+1,1)
0160          PLCT(KSP,1,2) = ARRAY(KSP+1,2)
0161          588      PLCT(KSP,1,3) = ARRAY(KSP+1,3)
C
C
C      COMPUTATION AND STORING IN ARRAYS OF THE LENGTHS OF THE LIMBS
C      AND OF THE DISTANCES BETWEEN THE ORIGINS OF THE LIMBS AND THAT
C      LIMB'S INTERMEDIARY POINT (RESPECTIVELY 'ALONG', AND 'CLONG').
C
0162      DO 810 MC=1,NN
0163          ALONG(MC) = DSQRT((ARRAY(MC+1,1)-ARRAY(MQ,1))**2 + (ARRAY(MQ+1,2)
I          -ARRAY(MQ,2))**2 + (ARRAY(MC+1,3) - ARRAY(MQ,3))**2)
0164          CLONG(MQ)=CSQRT((ARRAY(MQ+1,1)-ARRAY(MQ,4))**2+(ARRAY(MQ+1,2)-ARR
I          Y(MQ,5))**2 + (ARRAY(MQ+1,3)-ARRAY(MQ,6))**2)
0165          810      CCNTINUE
C
C
C      THE VALUES ARE GIVEN TO IPECS AFTER TRANSLATION TO SPHERICAL COORDINATES
C
0166      CC 331 MC=1,NN
0167          XLC=ARRAY(MC+1,1)-ARRAY(MQ,1)
0168          ARGONE =      ARRAY(MQ+1,2)-ARRAY(MQ,2)
0169          IF (ABS(ARGONE).LT.10-12.AND.UABS(XLC).LT.10-12) GO TO 329
0170          ANGLE1 = DATAN2(ARGONE, XLC)
0171          GC TC 330

```



```

0219 X1=ARRAY(NLMBL,1)
0220 Y1=ARRAY(NLMBL,2)
0221 Z1=ARRAY(NLMBL,3)
0222 ARRAY(NLMBL,1) = TEMPI1
0223 ARRAY(NLMBL,2) = TEMPI2
0224 ARRAY(NLMBL,3) = TEMPI3
0225 GO TO 5E76
C EQUATION AND PRINTING OF AXIS
C
C
C
C
C
C
C
C226 3E CONTINUE
C
C CASE OF PURE ROTATION
C
0227 IF(KTYPN.NE.3) GO TO 37
0228 KSIG=K SIG+1
0229 SIGX(KSIG)=ARRAY(NUMBL+1,1)
0230 SIGY(KSIG)=ARRAY(NUMBL+1,2)
0231 SIGZ(KSIG)=ARRAY(NUMBL+1,3)
0232 TEMPI=ALCNG(NLMBL)
0233 PA=(ARRAY(NUMBL+1,1)-ARRAY(NUMBL,1))/TEMPI
0234 FB=(ARRAY(NUMBL+1,2)-ARRAY(NUMBL,2))/TEMPI
0235 PC=(ARRAY(NUMBL+1,3)-ARRAY(NUMBL,3))/TEMPI
0236 IF(DABS(PA).LT.1.D-12) PA=0.
0237 IF(DABS(PB).LT.1.D-12) PB=0.
0238 IF(DABS(PC).LT.1.D-12) PC=0.
0239 XI=ARRAY(NUMBL,1)
0240 YI=ARRAY(NUMBL,2)
0241 ZI=ARRAY(NUMBL,3)
0242 XI=ARRAY(NUMBL+1,1)
0243 YI=ARRAY(NUMBL+1,2)
0244 ZI=ARRAY(NUMBL+1,3)
0245 GO TO 637
C
C
C
C
C CASE OF PLANAR MOVEMENT

```



```

C THE NEW COORDINATES ARE GIVEN TO THE PLOTTING ARRAY **PLOT**
C AND ARE GIVEN TO **ARRAY** WHERE THEY REPLACE THE FORMER VALUES
C OF THE LIMB WHOSE NEW EXTREMITY HAS BEEN COMPUTED
C
C282          39          CCNTINUE
C
C283          PLCT(NUMBL,KT+1,1) = XB
C284          PLCT(NUMBL,KT+1,2) = YB
C285          PLCT(NUMBL,KT+1,3) = ZB
C
C286          ARRAY(NUMBL+1,1) = XB
C287          ARRAY(NUMBL+1,2) = YB
C288          ARRAY(NUMBL+1,3) = ZB
C
C
C
C THE VALUES ARE TRANSLATED INTO SPHERICAL COORDINATES AND STORED
C IN THE ARRAY **IPECS**
C285          XLC = ARRAY(NUMBL+1,1)-ARRAY(NUMBL,1)
C290          ARGCNE =          ARRAY(NUMBL+1,2)-ARRAY(NUMBL,2)
C291          IF(DABS(ARGCNE).LT.1D-12.AND.DABS(XLC).LT.1D-12) GO TO 1329
C292          ANGLE1 = DATAN2(ARGCNE,XLC)
C293          GC TC 1330
C294          ANGLE1=0.
C295          CCNTINUE
C296          YOUFEE=(ARRAY(NUMBL+1,3)-ARRAY(NUMBL,3))/ALONG(NUMBL)
C297          IF(DABS(YOUFEE).GT.1.) YOUFEE=1.
C298          ANGLE2=CARCCS(YOUFEE)
C299          IF(ANGLE1.EQ.0.) SIGN=1.
C300          IF(ANGLE1.LT.0.) SIGN=-1.
C301          IPECS(NUMBL,KT+1,1)= ANGLE1*(180./PI) +.5 *SIGN
C302          IF(ANGLE2.EQ.0.) SIGN=1.
C303          IF(ANGLE2.LT.0.) SIGN=-1.
C304          IPECS(NUMBL,KT+1,2)= ANGLE2*(180./PI) +.5 *SIGN
C305          IF(KTYPN.EQ.0) GC TC 29
C
C          638          CCNTINUE
C306          IF(KSPGH.EC.1) NUMBL=NUMBL+1
C307          IF(NUMBL.GT.NN) GO TO 6C6
C308

```

```

C
C      FOIATION OF INTERMEDIARY PCINTS OF LIMB MOVED AND OF LIGHTER LIMBS
C
0309      EC 601 KYTE=NUMBL,NN
0310      YTRANS=ARRAY(KYTE,4) - XI
0311      YTRANS=ARRAY(KYTE,5) - YI
0312      ZTRANS=ARRAY(KYTE,6) - ZI
0313      CALL FINDPT(XTRANS,YTRANS,ZTRANS,PHI,PSI,THETA)
0314      ARRAY(KYTE,4) = XTRANS +XI
0315      ARRAY(KYTE,5) = YTRANS +YI
0316      ARRAY(KYTE,6) = ZTRANS +ZI
0317      601      CCNTINUE
C
0318      606      CCNTINUE
0319      IF(KSPCF.EC.I) NUMBL=NUMBL-1
C
C      RCIATION CF THE SYSTEM OF LIMBS LIGHTER THAN LIMB IN MOVEMENT
C
0320      NZ=NN+1
0321      NY=NUMBL+2
0322      IF(NY.GT.NZ) GO TO 6C5
0323      DO 6C2 KYTE=NY,NZ
0324      XTRANS=ARRAY(KYTE,1)-XI
0325      YTRANS=ARRAY(KYTE,2)-YI
0326      ZTRANS=ARRAY(KYTE,3)-ZI
0327      CALL FINDPT(XTRANS,YTRANS,ZTRANS,PHI,PSI,THETA)
0328      ARRAY(KYTE,1) = XTRANS+XI
0329      ARRAY(KYTE,2) = YTRANS+YI
0330      ARRAY(KYTE,3) = ZTRANS+ZI
0331      6C2      CCNTINUE
0332      6C5      CCNTINUE
0333      IF(KTYPN.NE.4.AND.KTYPN.NE.5) GO TO 29
0334      ANGLE(NUMBL,KI) = ROTR(NUMBL,KI)
0335      KTYPN=3
0336      KSPCH=1
0337      GO TO 35
C
0338      2CC      KI=KI-1
0339      KVIEW = KVIEW +I
C

```

```

C
C SCALING CF ARRAYS FOR PLOTTING
C
0340 SUM = 0.
0341 GO 220 LZ=I,KN
0342 SUM = SUM + ALONG(LZ)
0343 IF(ABS(OR1(I))) .GE. ABS(OR2(I)) .AND. ABS(OR1(I)) .GE. ABS(OR3(I)) GO
1 TO 222
0344 IF(ABS(OR2(I))) .GE. ABS(OR3(I)) GO TO 224
0345 SUM = SUM + ABS(CR3(I))
0346 GO TO 207
0347 224 SUM = SUM + ABS(CR2(I))
0348 GO TO 207
0349 222 SUM = SUM + ABS(OR1(I))
0350 UNITY = SUM/4.
0351 WRITE( 6, E71) UNITY
0352 TS(I)=0.
0353 TS(2)=UNITY
0354 TX(1) = -4.*UNITY
0355 TX(2)=UNITY
C
C DRAWING CF AXIS
0356 KVEEH = KVIEW - (KVIEW/10)*10
0357 XLIN(1) = 4. * UNITY
0358 YLIN(1) = 1.0 * UNITY
0359 XLIN(2) = 4.0 * UNITY
0360 YLIN(2) = 1.0 * UNITY
0361 XLJN(1) = 1.0 * UNITY
0362 YLJN(1) = 4.C * UNITY
0363 XLJN(2) = 7.0 * UNITY
0364 YLJN(2) = 4.C * UNITY
0365 CR1(2) = C.
0366 CR2(2) = C.
0367 CR3(2) = C.
0368 CR1(3) = UNITY
0369 CR2(3) = UNITY
0370 CR3(3) = UNITY
0371 XTRACE(1) = CR1(1)
0372 YTRACE(1) = CR2(1)
0373 ZTRACE(1) = CR3(1)
0374 KP = KT+1

```

```

0375      KZ=KP+1
0376      XPLI(KP+1) = XPLI(I)
0377      YPLI(KP+1) = YPLI(I)
0378      ZPLI(KP+1) = ZPLI(I)
0379      XPLI(KP+2) = 0.
0380      YPLI(KP+2) = C.
0381      ZPLI(KP+2) = 0.
0382      XPLI(KP+3) = UNITY
0383      YPLI(KP+3) = UNITY
0384      ZPLI(KP+3) = UNITY
0385      KWCK = KZ/5
0386      TSA(I)=C.
0387      TSA(2)=-TS(2)
0388      SIGX(KSIG+1)=C.
0389      SIGY(KSIG+1)=0.
0390      SIGZ(KSIG+1)=C.
0391      SIGX(KSIG+2)=-UNITY
0392      SIGY(KSIG+2)= UNITY
0393      SIGZ(KSIG+2)= UNITY
0394      ALX(1)= -C.5
0395      ALX(2)= -0.5
0396      ALX(3)=  E.5
0397      ALX(4)=  8.5
0398      ALX(5)= -C.5
0399      ALY(1)= -0.5
0400      ALY(2)=  8.5
0401      ALY(3)=  E.5
0402      ALY(4)= -C.5
0403      ALY(5)= -0.5
0404      TM(1)=C.
0405      TM(2)=1.
C
C   PRINTING ROUTINE
C
0406      DC 266 KPL=1,AN
0407      WRITE(6,876) KPL
0408      WRITE(6,874)
0409      LU 199 KH=1,KI
0410      KE=KH-1
0411      WRITE(6,875) KE,(PLJ(KPL,KH,MPL),MPL=1,3),(IPECS(KPL,KH,MPH),MPH=
      11,2)
C412      199  CONTINUE
0413      266  CONTINUE

```



```

0448 XPL1(KZ+2)= UNITY
0449 CO 290 NLABEL=1,KWOM
0450 PTEMP=NLABEL*5-4
0451 ANBR = NLABEL+.1
0452 YCCOR=YPL1(MTEMP)/UNITY
0453 YCCOR=XPL1(MTEMP)/(-UNITY)
0454 CALL CCP3NR(XCCOR,YCCOR,0.1,ANBR,0.0,-1)
0455 CONTINUE
0456 CRI(3)=-UNITY
0457 CRI(3)= UNITY
0458 GO TO 285
0459 XPL1(KZ+2)=-UNITY
0460 CALL LINE (XPL1,ZPL1,KZ,I,5,03)
0461 CALL CCP2SY(-4.3,-0.5,0.3,103,0.0,-1)
0462 CALL CCP2SY(-0.5,4.0,0.3,105,0.0,-1)
0463 IF(KSIG.EQ.0) GO TO 7001
0464 CONTINUE
0465 XPL1(KZ+2)= UNITY
0466 CO 291 NLABEL=1,KWOM
0467 PTEMP=NLABEL*5-4
0468 ANBR = NLABEL+.1
0469 YCCOR=XPL1(MTEMP)/(-UNITY)
0470 YCCOR=ZPL1(MTEMP)/UNITY
0471 CALL CCP3NR(XCCOR,YCCOR,0.1,ANBR,0.0,-1)
0472 CONTINUE
0473 CRI(3)=-UNITY
0474 CRI(3)= UNITY
0475 GO TO 285
0476 CALL LINE (YPL1,ZPL1,KZ,I,5,03)
0477 CALL CCP2SY(4.0,C.0,0.3,104,0.0,-1)
0478 CALL CCP2SY(0.0,4.0,0.3,105,0.0,-1)
0479 IF(KSIG.EQ.0) GO TO 7002
0480 CONTINUE
0481 CO 292 NLABEL=1,KWOM
0482 PTEMP=NLABEL*5-4
0483 ANBR = NLABEL+.1
0484 YCCOR= YPL1(MTEMP)/UNITY
0485 YCCOR=ZPL1(MTEMP)/UNITY
0486 CALL CCP3NR(XCCOR,YCCOR,0.1,ANBR,0.0,-1)
0487 CONTINUE
0488 CONTINUE
0489 CONTINUE

```



```

0001 SUBROUTINE TRANSL(L,K,R,KANGLE,X,Y,Z,KTEST)
0002 I=PI*REAL*8*(A-F,U-Z)
0003 250 FORMAT(32H IMPROPER E-W COORDINATES GIVEN )
0004 IF((K*KANGLE).GT.180.OR.K.LT.0) GO TO 200
0005 IF((L+1)*KANGLE).GT.360.OR.L.LT.0) GO TO 200
0006 PI=3.1415926535
0007 KTEST=0
0008 IF((180/KANGLE).EQ.K) GO TO 160
0009 IF(K.EQ.C) GC TC 165
0010 TETA=360-(L*KANGLE)
0011 TETA=TETA*(PI/180.)
0012 PHI=180-(K*KANGLE)
0013 PHI=PHI*(PI/180.)
0014 X=R*DSIN(PHI)*DCOS(TETA)
0015 Y=R*CSIN(PHI)*DSIN(TETA)
0016 Z=R*CCOS(PHI)
0017 RETURN
0018 C CASE CF NORTH POLE
0019 160 Z=F
0019 Y=C.
0020 X=C.
0021 RETURN
0021 C CASE CF SOUTH POLE
0022 165 Z=-R
0023 Y=C.
0024 X=C.
0025 RETURN
0026 200 WRITE(6,250)
0027 KTEST=1
0028 201 RETURN
0029 END

```

```

C001 SUBROUTINE FINDPT (HEX,WHY,ZEE,PHI,PSI,THETA)
0002 IMPLICIT REAL*8 (A-F,U-Z)
0003 SPFI=DSIN(PHI)
0004 SPSI=DCOS(PHI)
0005 STHETA=DSIN(THETA)
0006 CPFI=DCOS(PHI)
0007 CPSI=DCOS(PSI)
0008 CTFETA=LCCS(THETA)
0009 TA=HEX
0010 TB=WHY
0011 TC=ZEE
0012 FEX=TA*(CPSI*CPFI-SPSI*CTHETA*SPHI)+TB*(SPSI*CPHI+CPHI*CTHETA*SPH
      11)+TC*STHETA*SPHI
0013 WHY=TC*STHETA*CPHI-TA*(CPSI*SPHI+SPSI*CTHETA*CPHI)+TB*(CPSI*CTHET
      1A*CPHI-SPSI*SPHI)
0014 ZEE=TA*SPSI*STHETA-TB*CPHI*STHETA+TC*CTHETA
0015 TA=HEX
0016 TB=WHY
0017 TC=ZEE
0018 FEX=TA*CPFI-TB*CTHETA*SPSI+TC*STHETA*SPSI
0019 WHY=TA*SPSI+TB*CTHETA*CPHI-TC*STHETA*CPHI
0020 ZEE=TB*STHETA+TC*CTHETA
0021 RETURN
0022 END

```

APPENDIX Ic. SAMPLE PLOTS OF DANCER

Ic-1. A one limb case where:

The first limb describes one fourth of a vertical counter clockwise circle for 20 timesteps then describes one-half of a cone for 20 more timesteps.

In E-W notation:

$$l = 45^\circ$$

$$\begin{pmatrix} 6 \\ 2 \end{pmatrix} \parallel \begin{pmatrix} 0 \\ 4 \end{pmatrix}_{2+} \parallel \begin{pmatrix} \hat{6} \\ 3 \end{pmatrix}_4$$

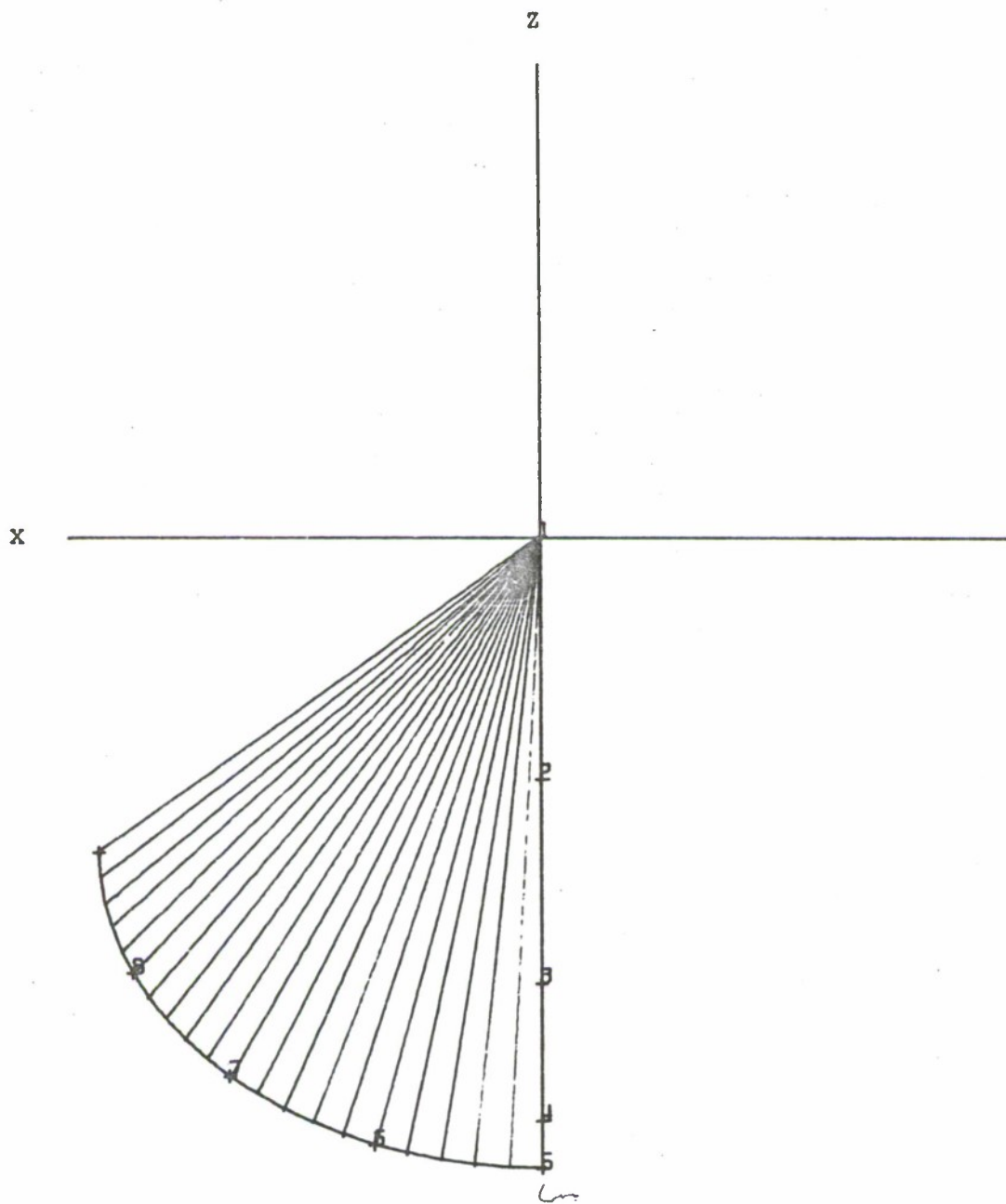

Ic-1.1. X-Z projection.

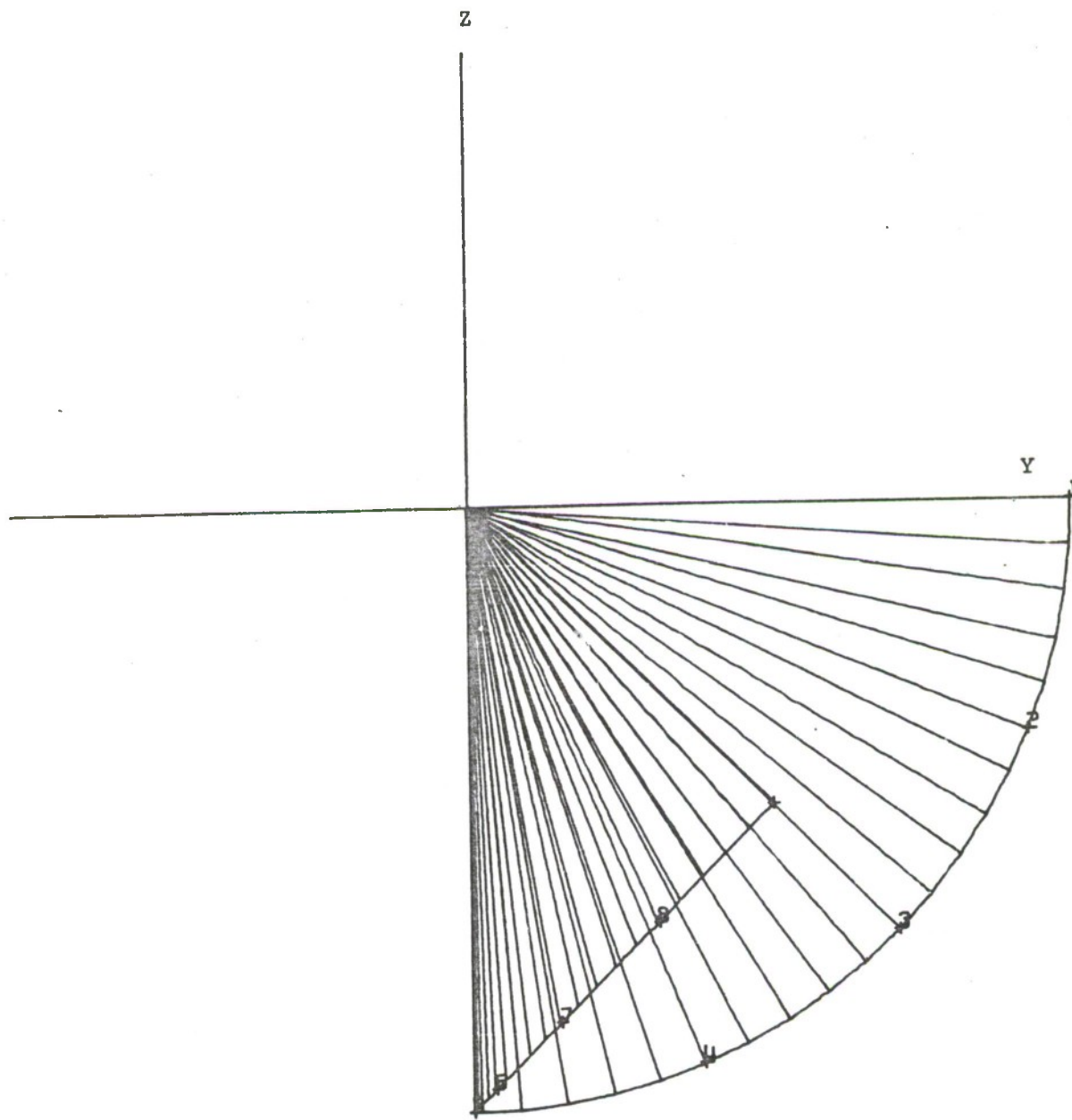

Ic-1.2. Y-Z projection.

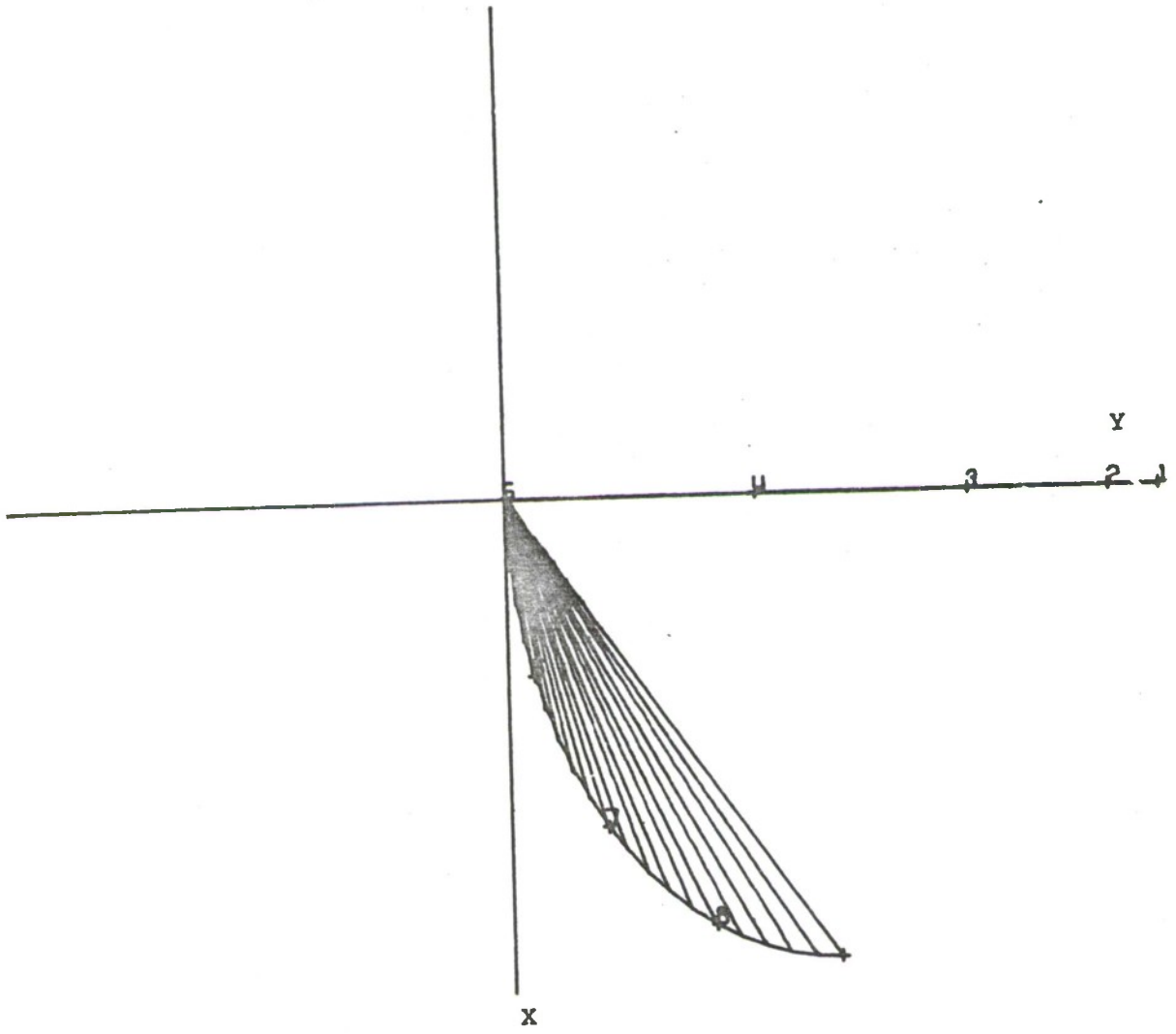

Ic-1.3. X-Y projection.

Ic-2. A two limb case where:

The first limb describes a counter clockwise cone with $\begin{pmatrix} 4 \\ 3 \end{pmatrix}$ and $\begin{pmatrix} 0 \\ 3 \end{pmatrix}$ as diameter extremities, while rotating on itself clockwise by 360°

The second limb has no movement of its own.

In E-W notation

$$l = 45^\circ$$

$$\begin{pmatrix} 4 \\ 3 \end{pmatrix} \left\| \begin{pmatrix} \hat{0} \\ 3 \end{pmatrix} \right. \hat{4} \hat{8}$$

$$\begin{pmatrix} 6 \\ 2 \end{pmatrix} \left\| \begin{pmatrix} 6 \\ 2 \end{pmatrix} \right.$$

The position is indicated for every 5 timesteps (normal line density).

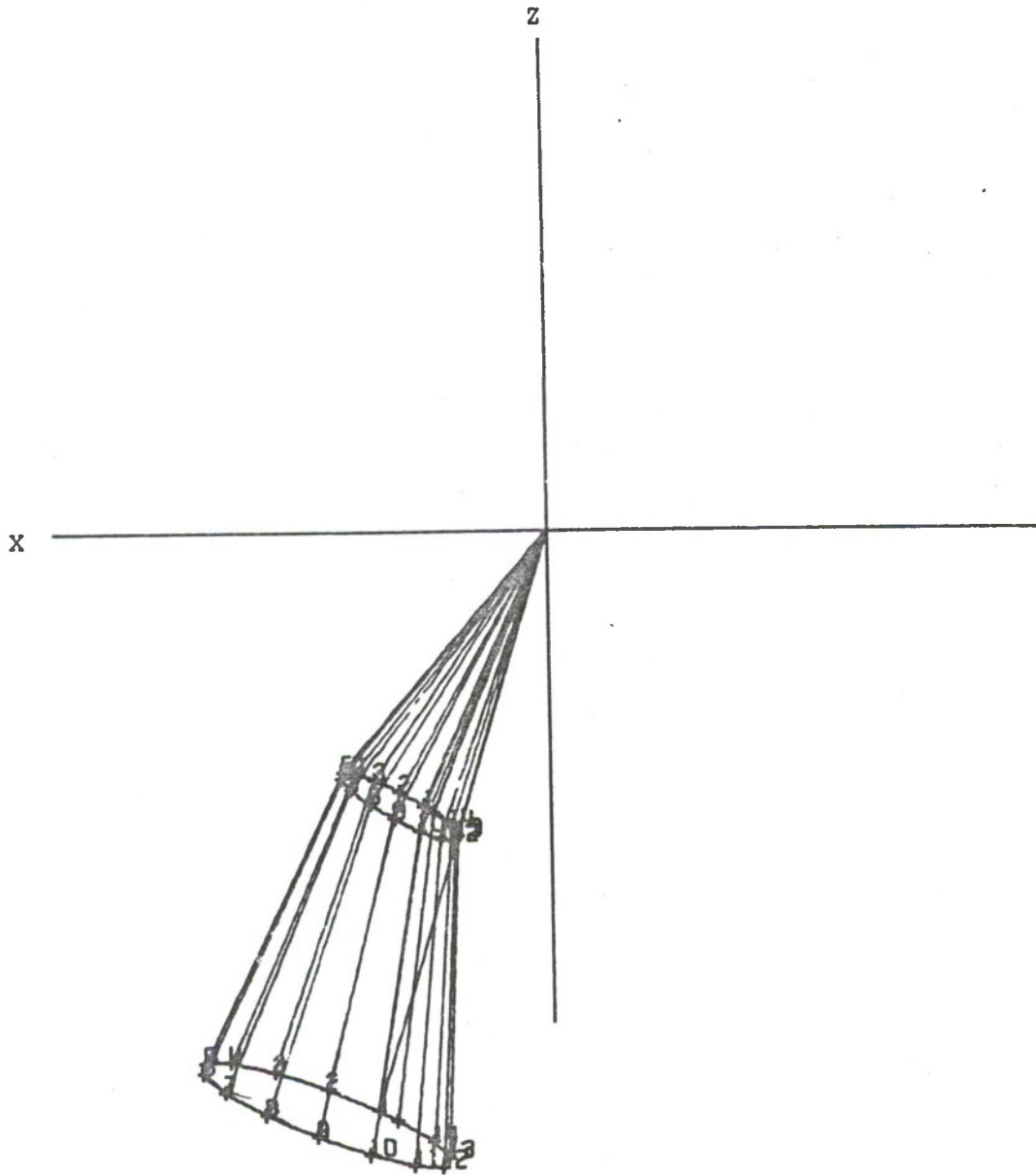

Ic-2.1. X-Z projection.

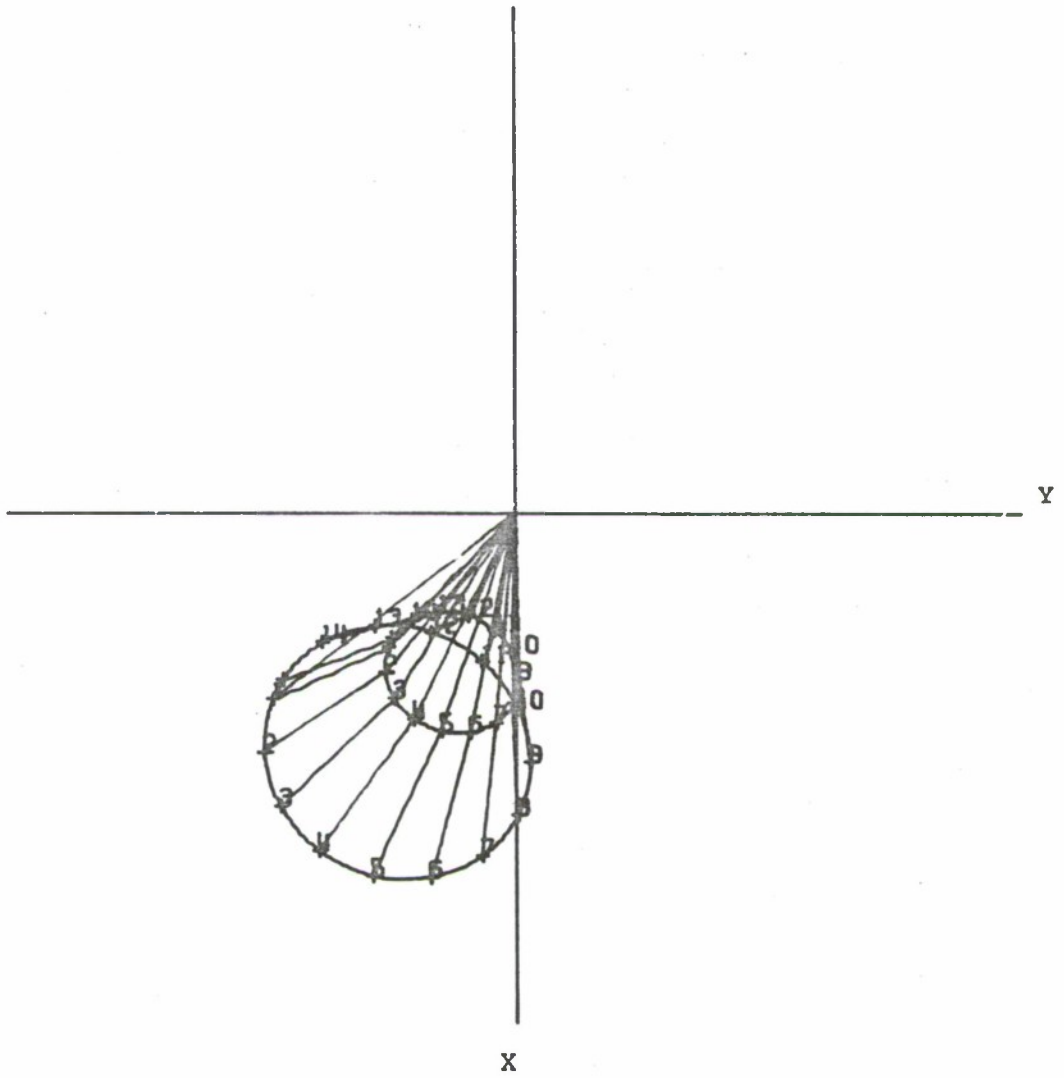

Ic-2.2. X-Y projection.

Ic-3. A two limb case where:

The first limb describes a counter clockwise cone with diameter extremities $\begin{pmatrix} 0 \\ 3 \end{pmatrix}$ and $\begin{pmatrix} 4 \\ 3 \end{pmatrix}$, while rotating on itself counter clockwise by 360° .

The second limb has no movement of its own.

In E-W notation

$$l = 45^\circ$$

$$\begin{pmatrix} 6 \\ 3 \end{pmatrix} \parallel \parallel \begin{pmatrix} \hat{0} \\ 3 \end{pmatrix} \text{ 4 } \mathfrak{g}$$

$$\begin{pmatrix} 6 \\ 2 \end{pmatrix} \parallel \parallel \begin{pmatrix} 6 \\ 2 \end{pmatrix}$$

The position is indicated for every 5 timesteps (normal line density).

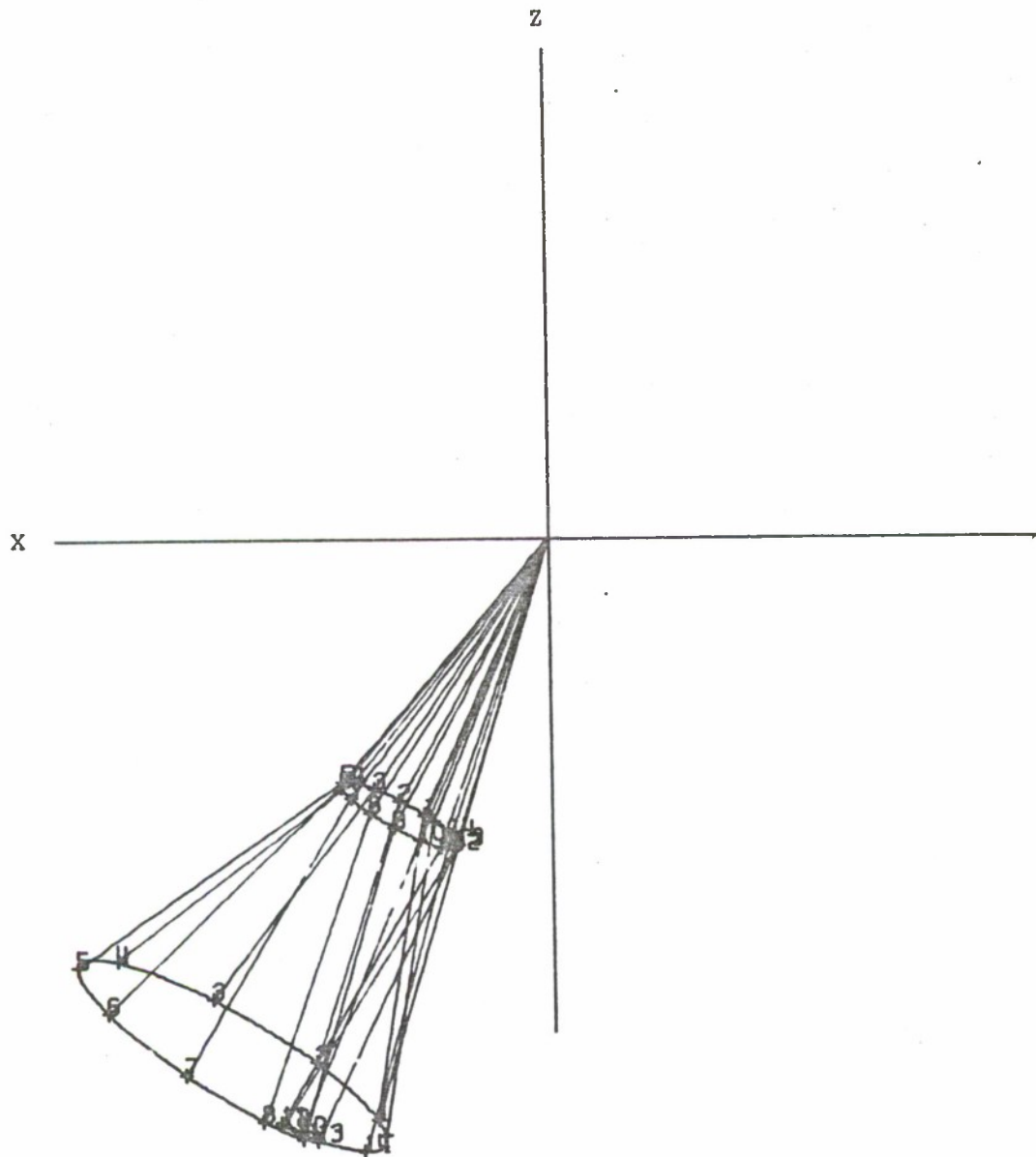

Ic-3.1. X-Z projection.

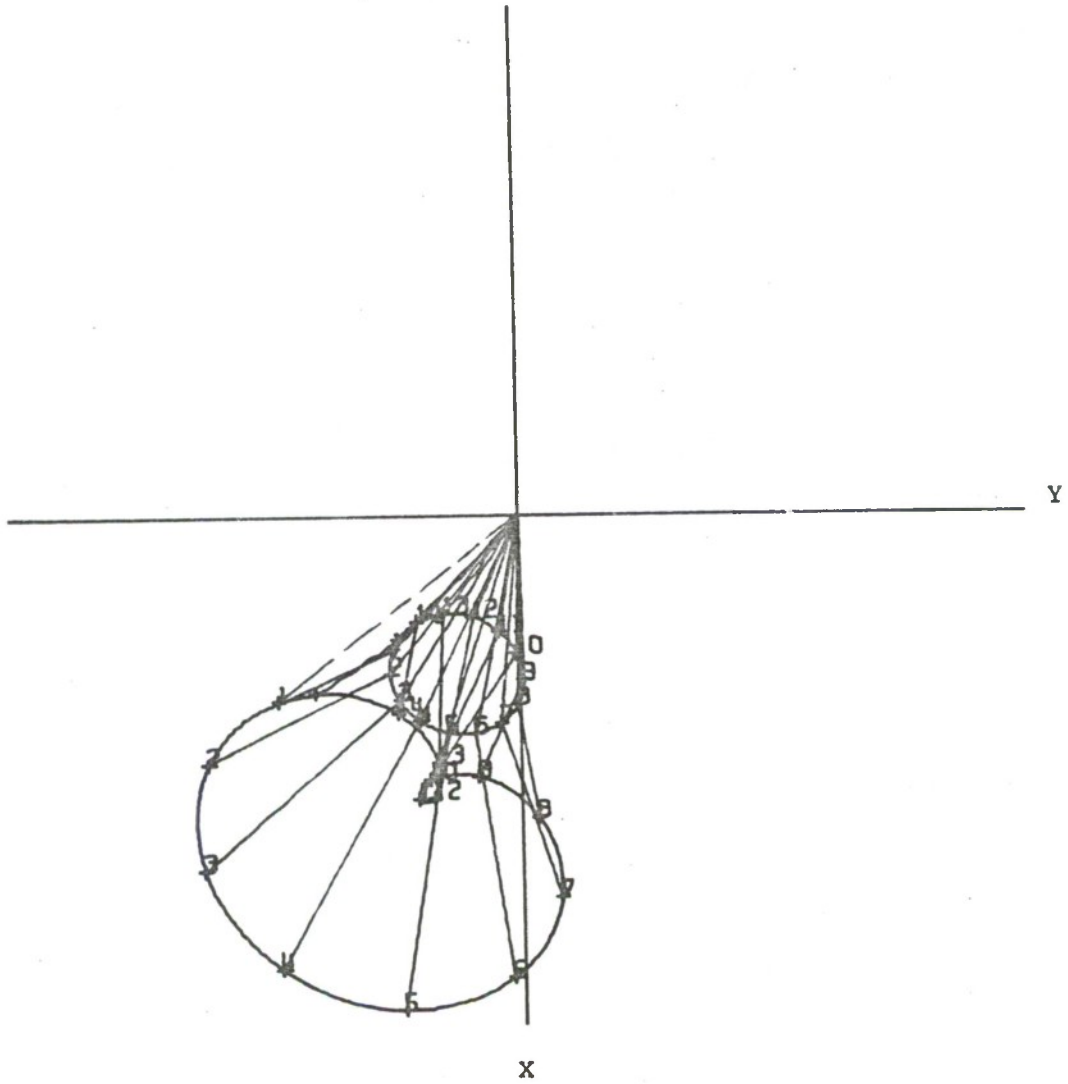

Ic-3.2. X-Y projection.

Ic-4. A two limb case where:

The first limb describes a counter clockwise horizontal circle.

The second limb describes three counter clockwise circles.

In E-W notation

$$l = 45^\circ$$

$$\begin{array}{c} \left(\begin{array}{c} 6 \\ 2 \end{array} \right) \\ \left(\begin{array}{c} 0 \\ 4 \end{array} \right) \end{array} \left| \left| \begin{array}{c} 8 \\ 24 \end{array} \right. \right.$$

The position is indicated for every 2 timesteps (half of maximum line density).

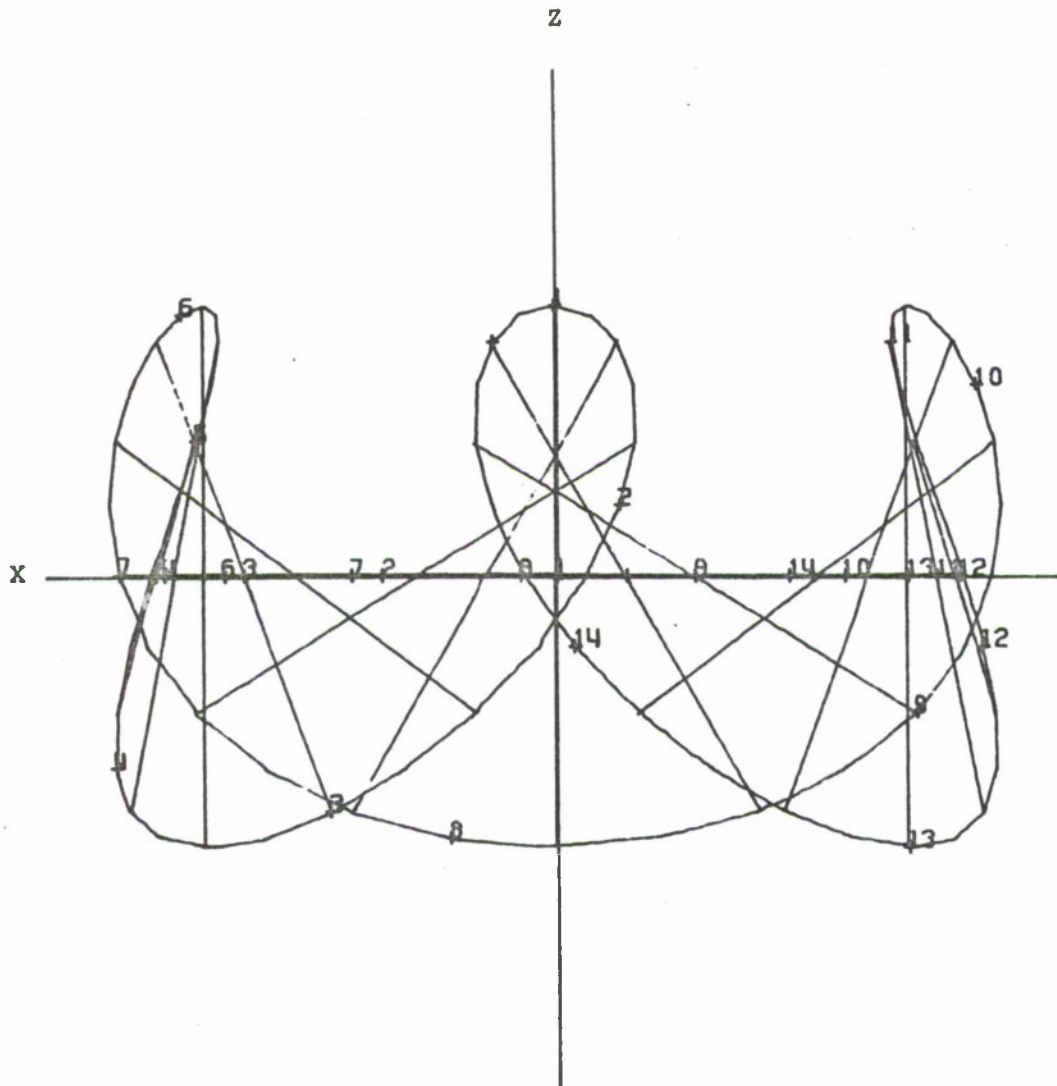

Ic-4.1. X-Z projection.

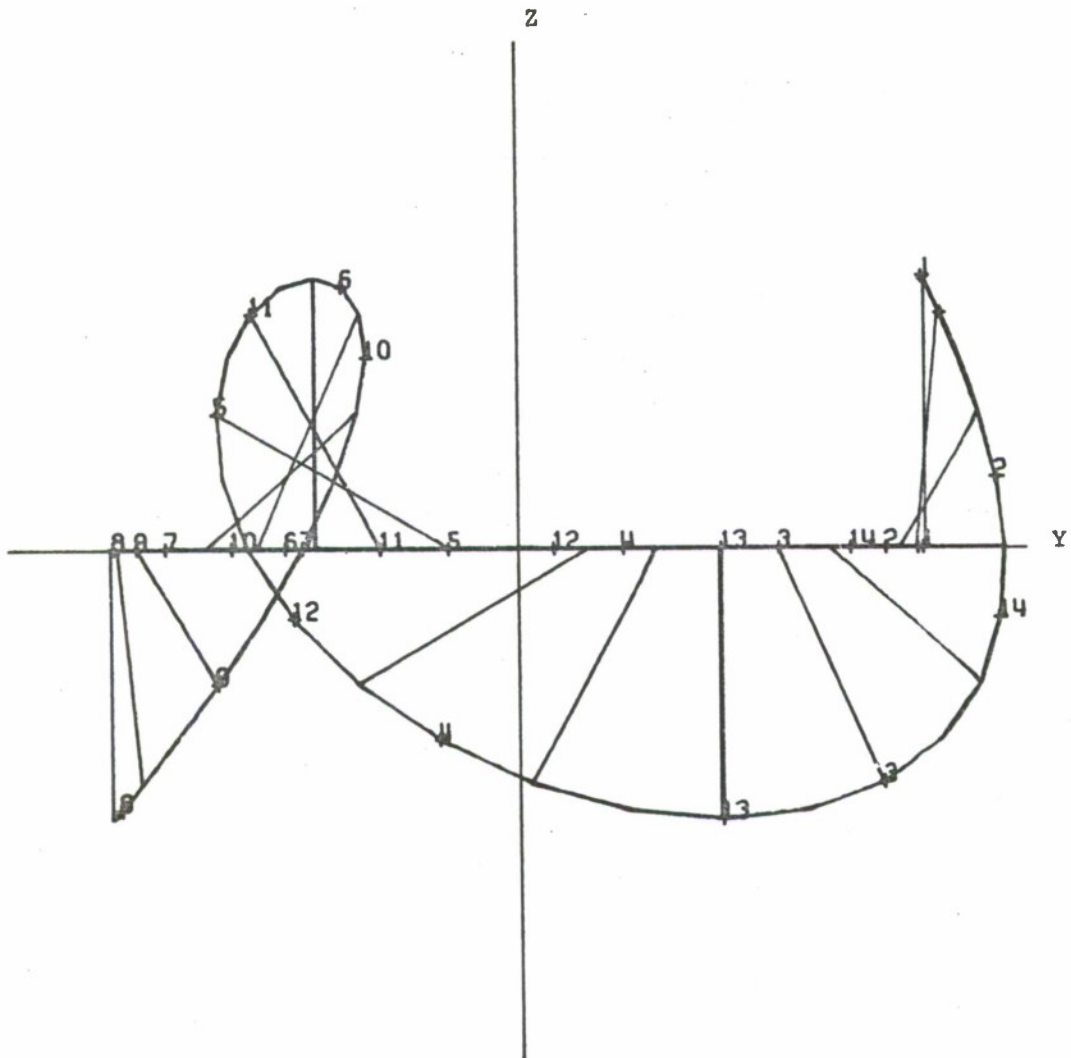

Ic-4.2. Y-Z projection.

Ic-5. A two limb case where:

The first limb describes half a counter clockwise circle passing through $\begin{pmatrix} 2 \\ 3 \end{pmatrix}$ and $\begin{pmatrix} 4 \\ 2 \end{pmatrix}$.

The second limb describes a counter clockwise cone with diameter extremities $\begin{pmatrix} 1 \\ 3 \end{pmatrix}$ and $\begin{pmatrix} 6 \\ 3 \end{pmatrix}$.

In E-W notation

$$l = 45^\circ$$

$$\begin{array}{c} \begin{pmatrix} 4 \\ 2 \end{pmatrix} \\ \begin{pmatrix} 6 \\ 3 \end{pmatrix} \end{array} \parallel \begin{array}{c} \begin{pmatrix} 2 \\ 3 \end{pmatrix} \\ \begin{pmatrix} \hat{1} \\ 3 \end{pmatrix} \end{array} \begin{array}{l} \perp 4 \\ \textcircled{3} \end{array}$$

The position is indicated for every timestep (maximum line density).

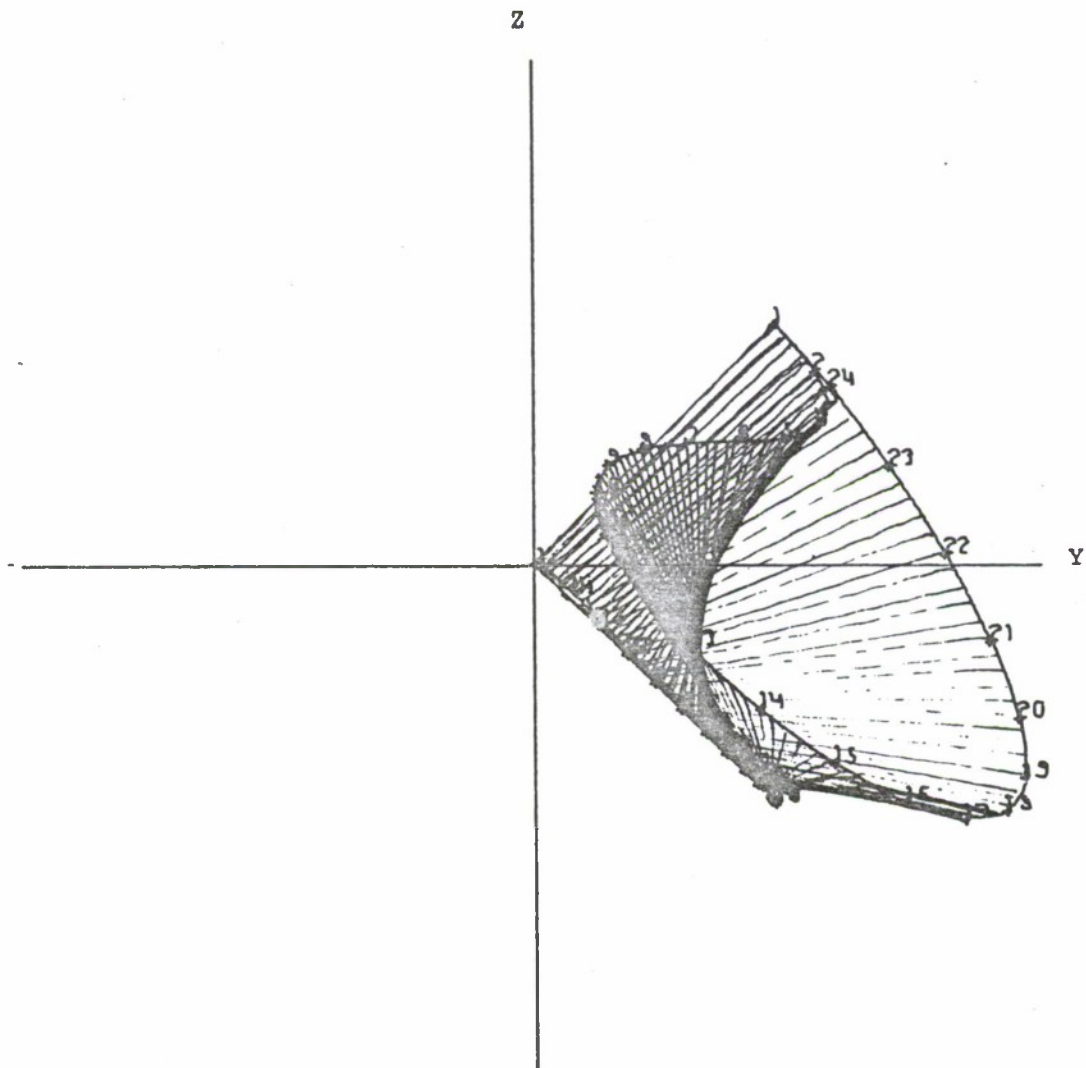

Ic-5.2. Y-Z projection.

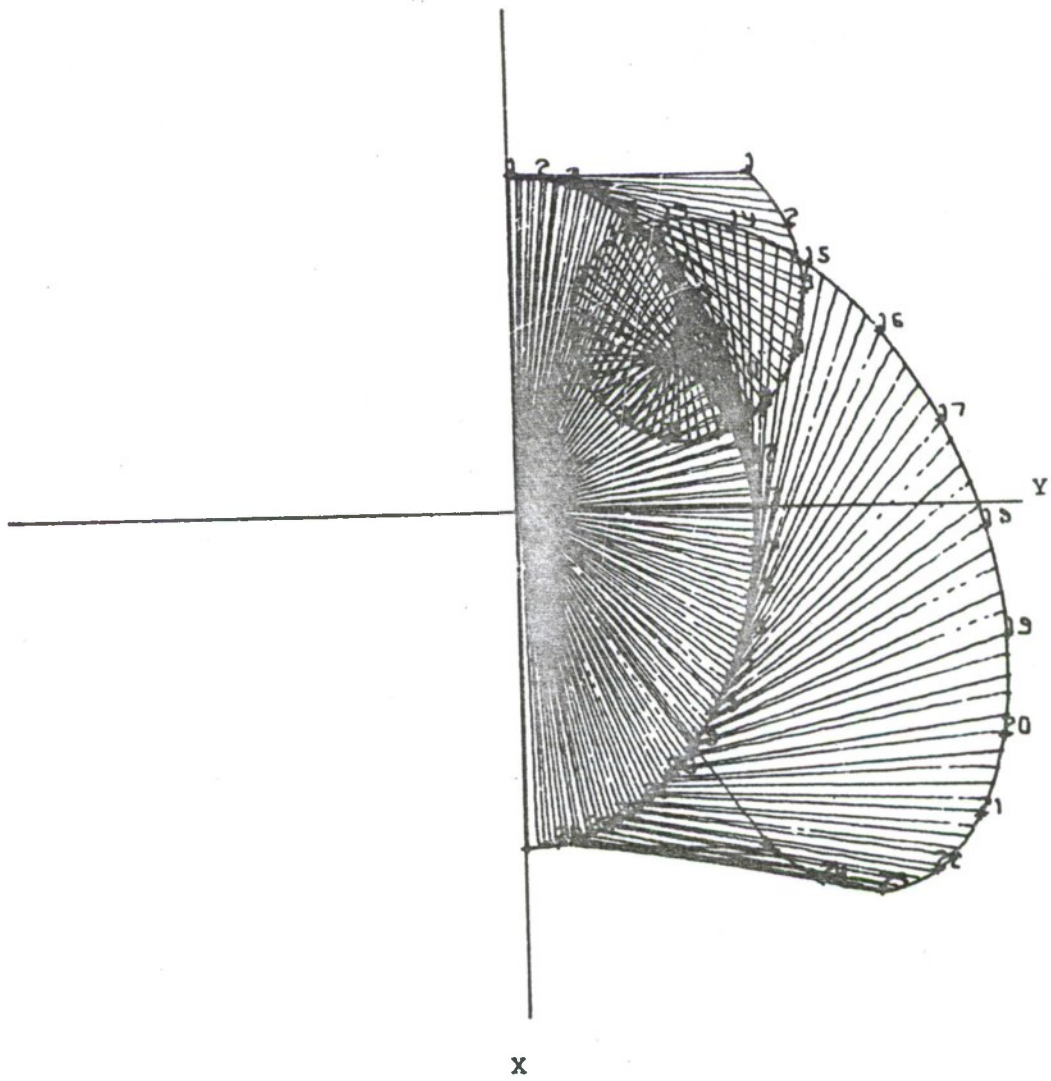

Ic-5.3. X-Y projection.

Ic-6. A three limb case where:

The first limb describes a third of a counter clockwise horizontal circle.

The second limb describes a fourth of a circle while rotating on itself.

The third limb has no movement of its own.

In E-W notation:

$$l = 45^\circ$$

$$\begin{array}{c} \left(\begin{array}{c} 6 \\ 2 \end{array} \right) \\ \left(\begin{array}{c} 0 \\ 4 \end{array} \right) \\ \left(\begin{array}{c} 6 \\ 2 \end{array} \right) \end{array} \left| \left| \begin{array}{c} \left(\begin{array}{c} 4 \\ 2 \end{array} \right) \begin{array}{l} 2 \\ \rightarrow \end{array} \\ \left(\begin{array}{c} 6 \\ 2 \end{array} \right) \underline{2} \\ \left(\begin{array}{c} 6 \\ 2 \end{array} \right) \end{array} \right.$$

Maximum line density.

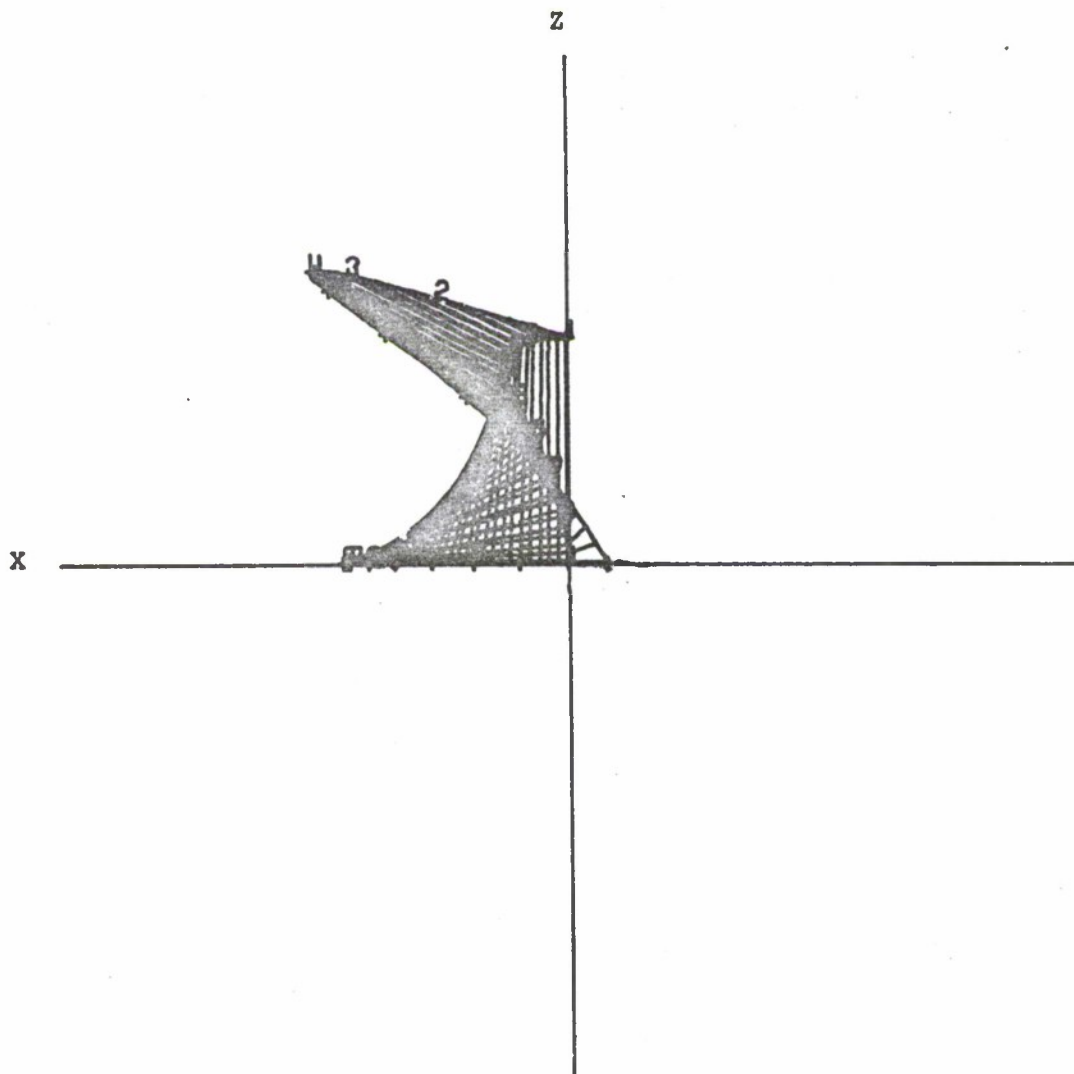

Ic-6.1. X-Z projection.

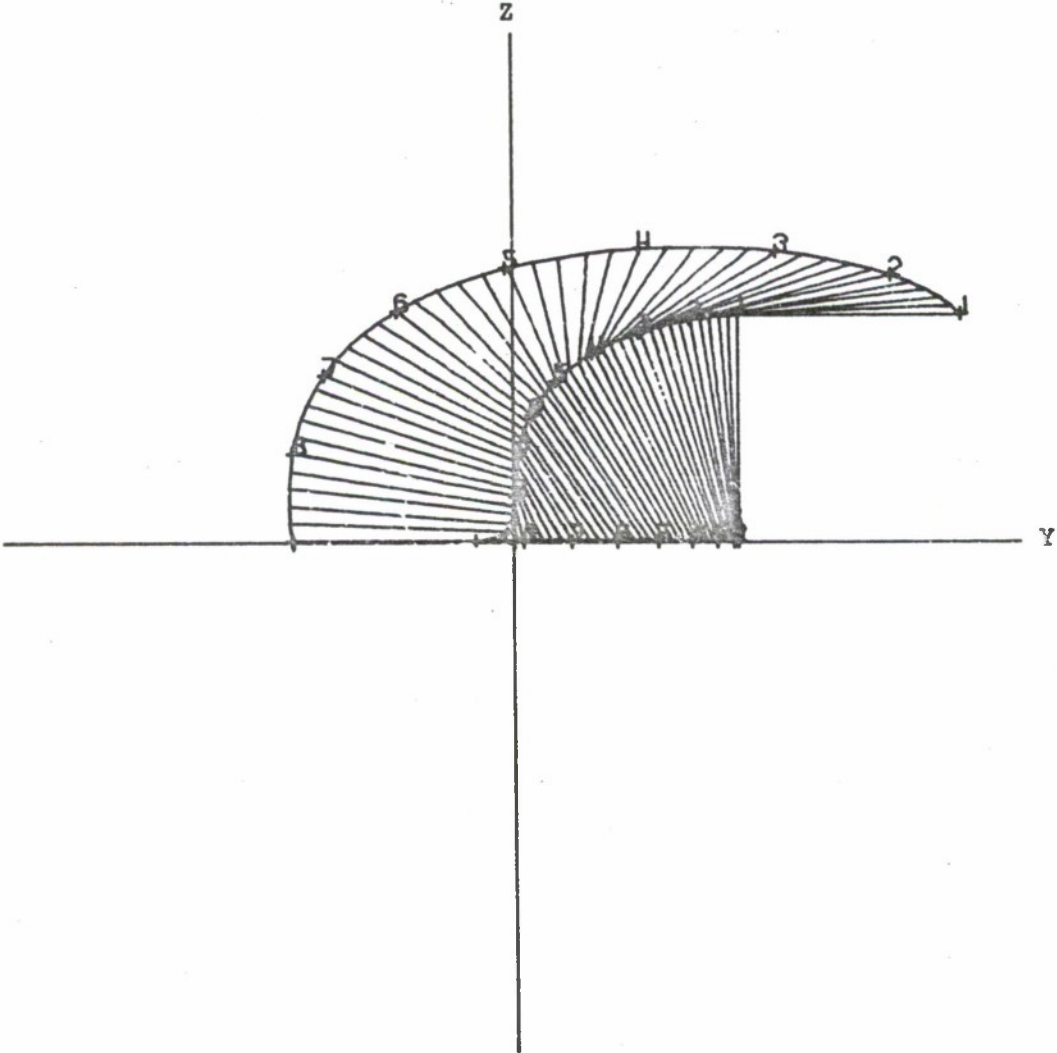

Ic-6.2. Y-Z projection.

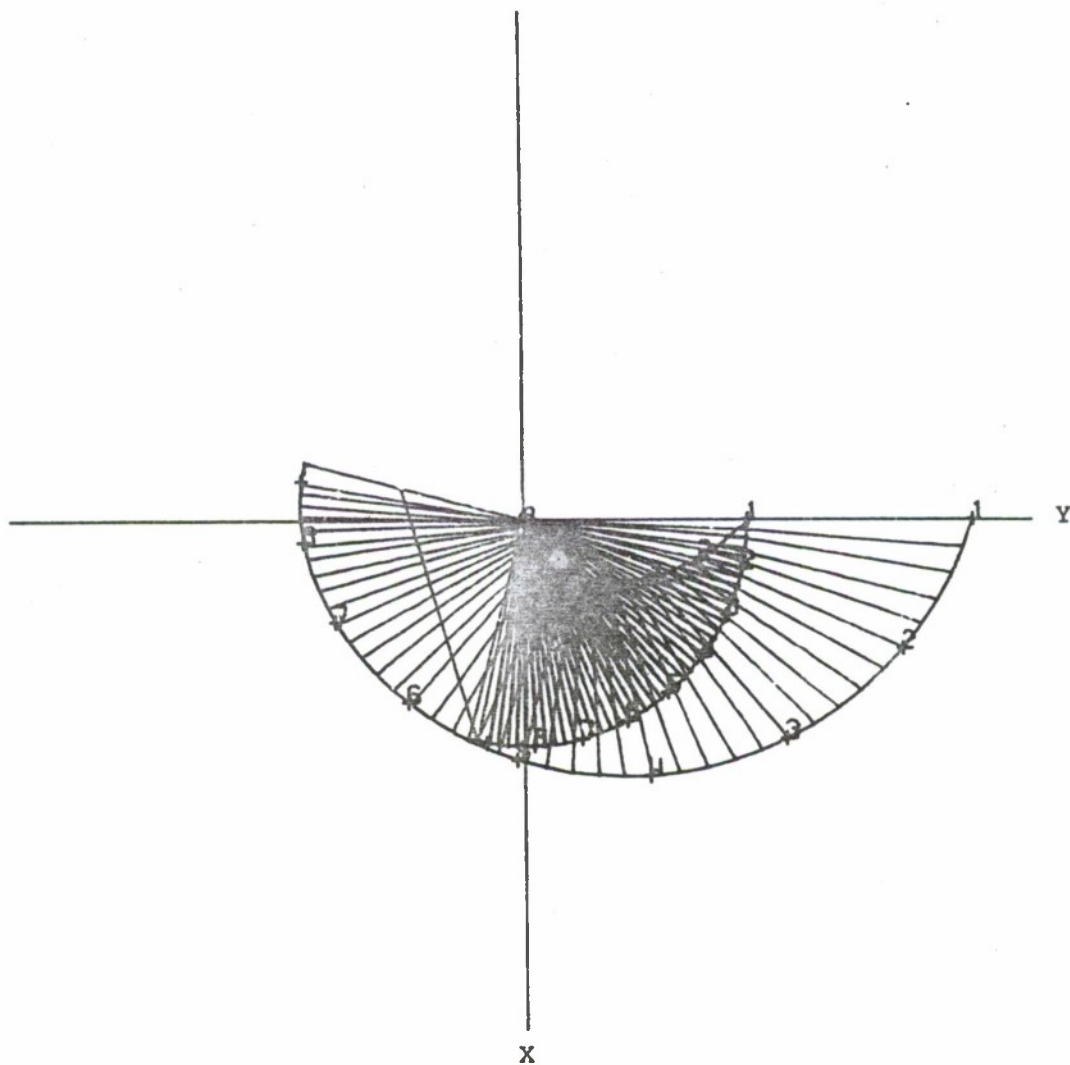

Ic-6.3. X-Y projection.

Ic-7. A three limb case where:

The first limb describes half of a horizontal counter clockwise circle while rotating on itself counter clockwise by 360°

The second limb describes a third of a vertical circle while rotating on itself clockwise by 180° .

The third limb describe a quarter of a circle.

In E-W notation

$$l = 45^\circ$$

$$\begin{array}{l} \left(\begin{array}{c} 2 \\ 2 \end{array} \right) \\ \left(\begin{array}{c} 2 \\ 2 \end{array} \right) \\ \left(\begin{array}{c} 2 \\ 2 \end{array} \right) \end{array} \left| \begin{array}{l} 4 \quad 8 \\ + \quad \curvearrowright \\ 2+ \quad \widehat{4} \\ 2+ \end{array} \right.$$

Maximum line density.

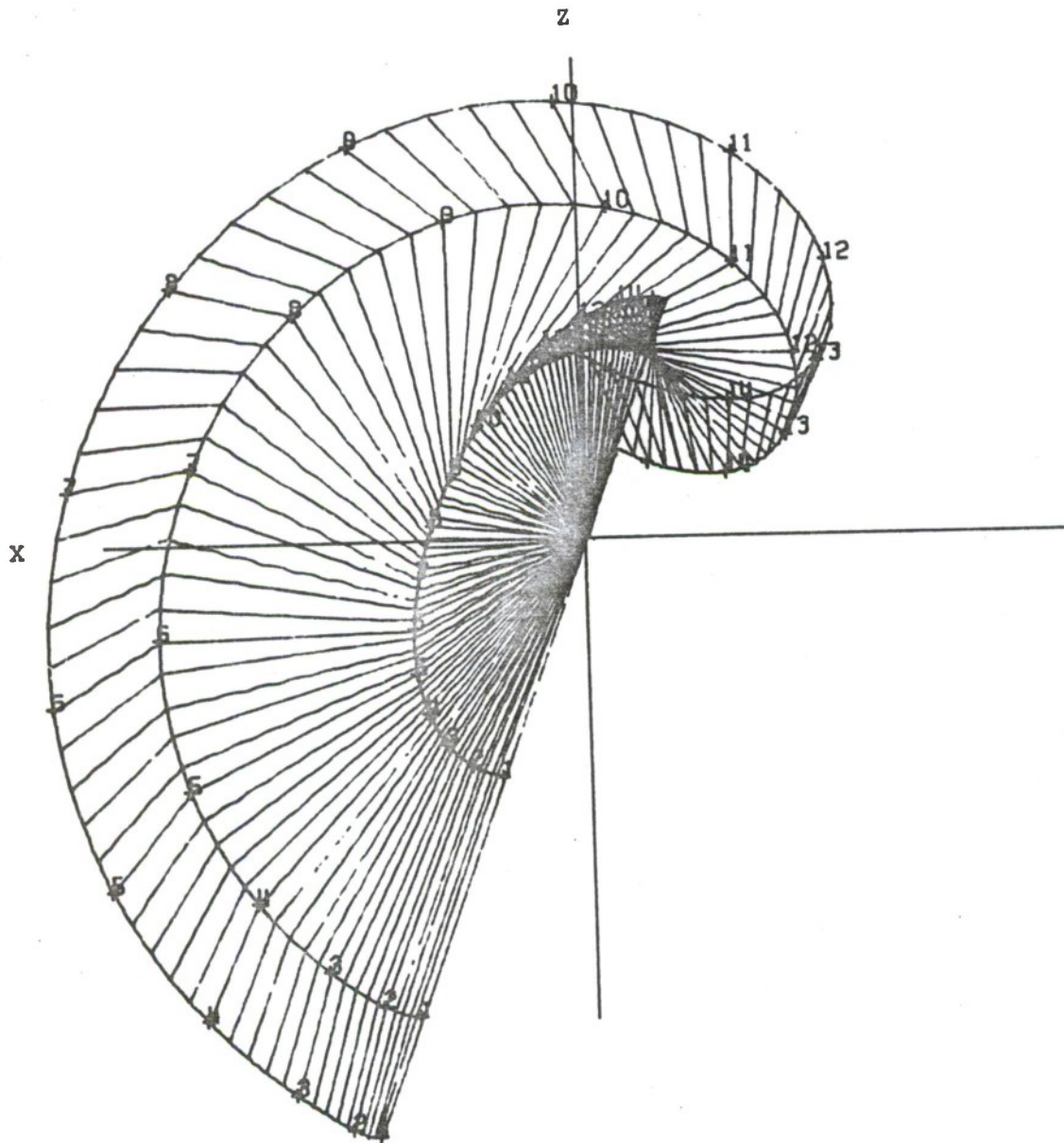

Ic-7.1. X-Z projection.

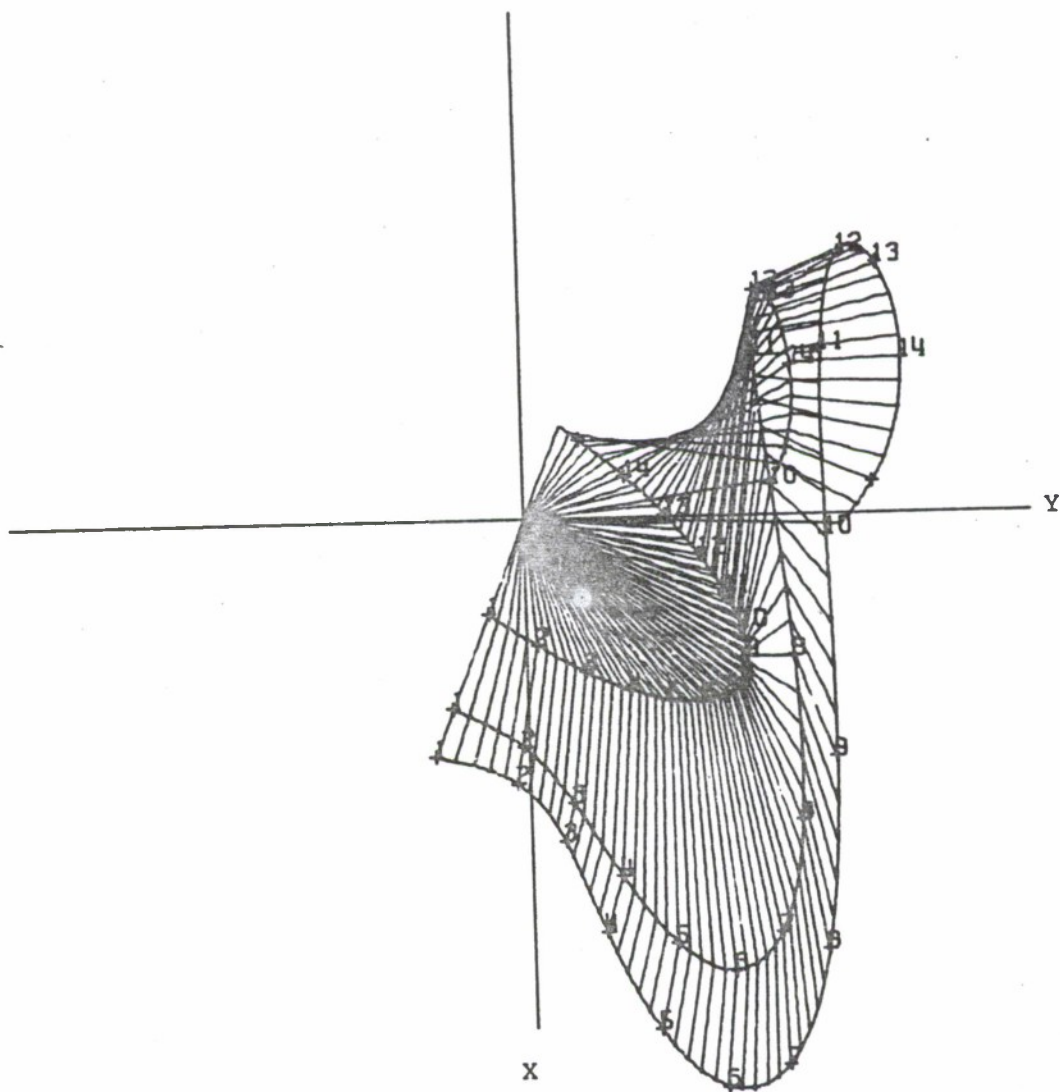

Ic-7.2. X-Y projection.

Ic-8. A three limb case where:

The first limb describes half a cone
for 72 timesteps.

The second limb describes one fourth
of a circle for 36 timesteps.

The third limb describes three fourths
of a cone for 36 timesteps.

In E-W notation

$$l = 45^\circ$$

$$\begin{array}{c} \begin{pmatrix} 6 \\ 2 \end{pmatrix} \\ \begin{pmatrix} 0 \\ 4 \end{pmatrix} \\ \begin{pmatrix} 0 \\ 4 \end{pmatrix} \end{array} \left\| \begin{array}{c} \hat{\begin{pmatrix} 5 \\ 2 \end{pmatrix}} \\ \begin{pmatrix} 6 \\ 2 \end{pmatrix} \\ \hat{\begin{pmatrix} 7 \\ 1 \end{pmatrix}} \end{array} \right. \begin{array}{c} 2 \parallel \hat{2} \\ 2 \\ 7 \end{array}$$

Maximum line density.

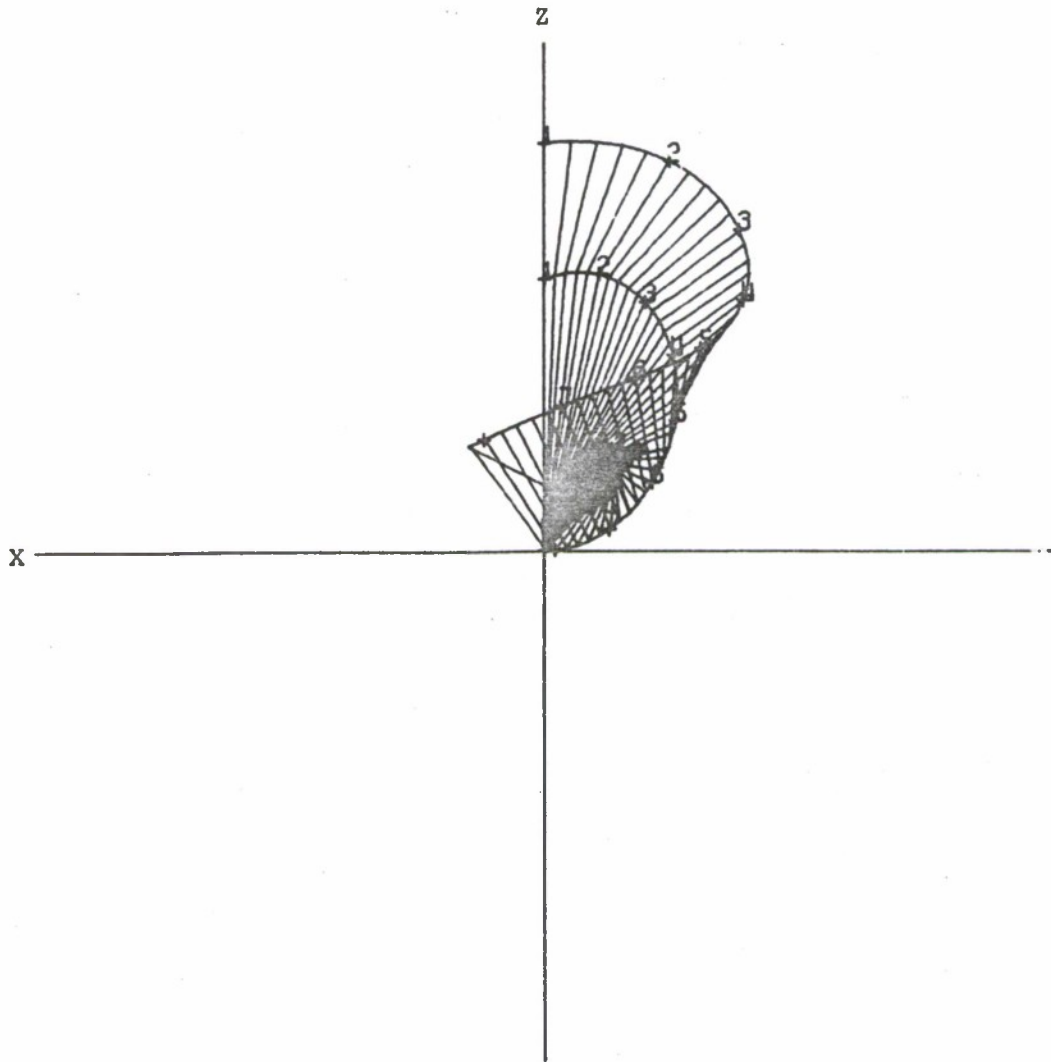

Ic-8.1. X-Z projection.

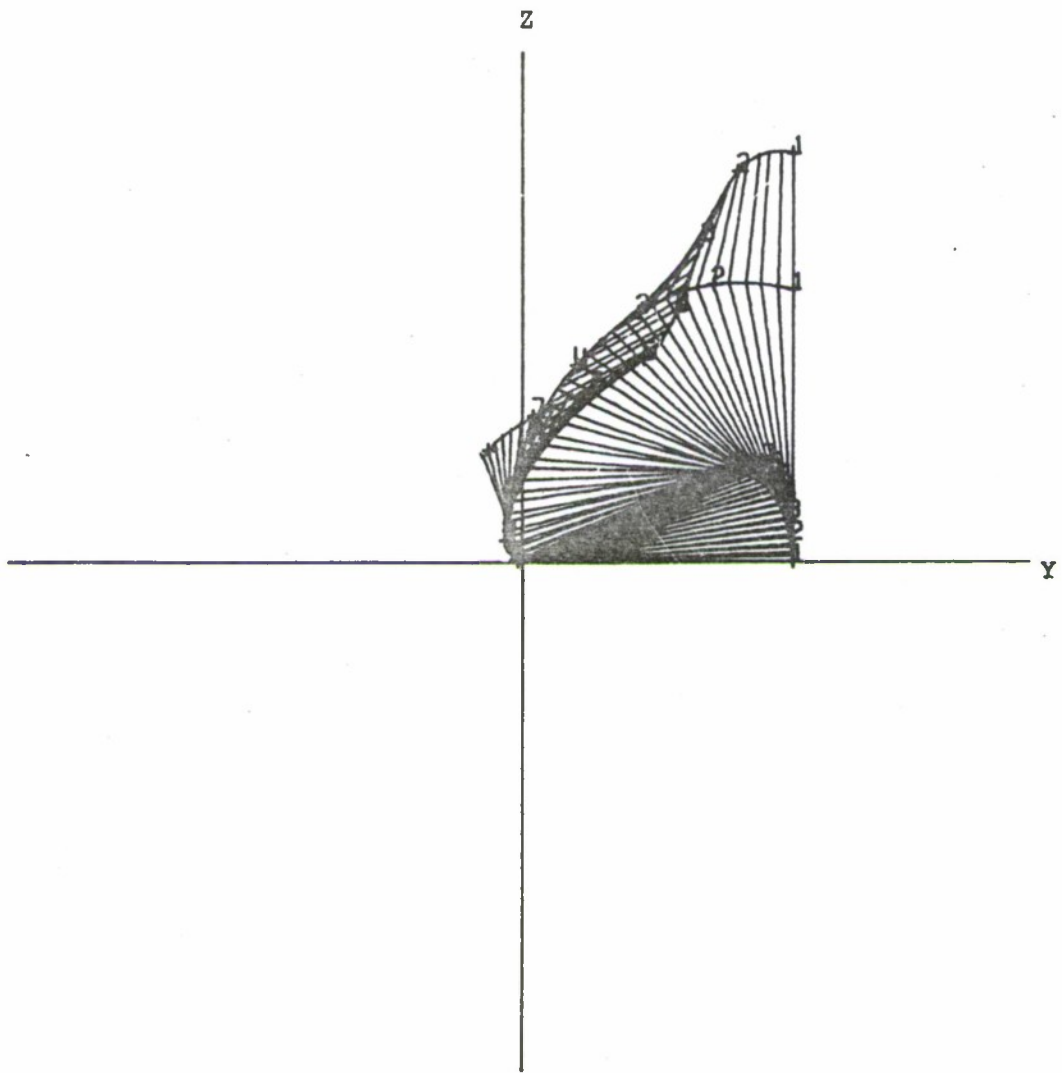

Ic-8.2. Y-Z projection.

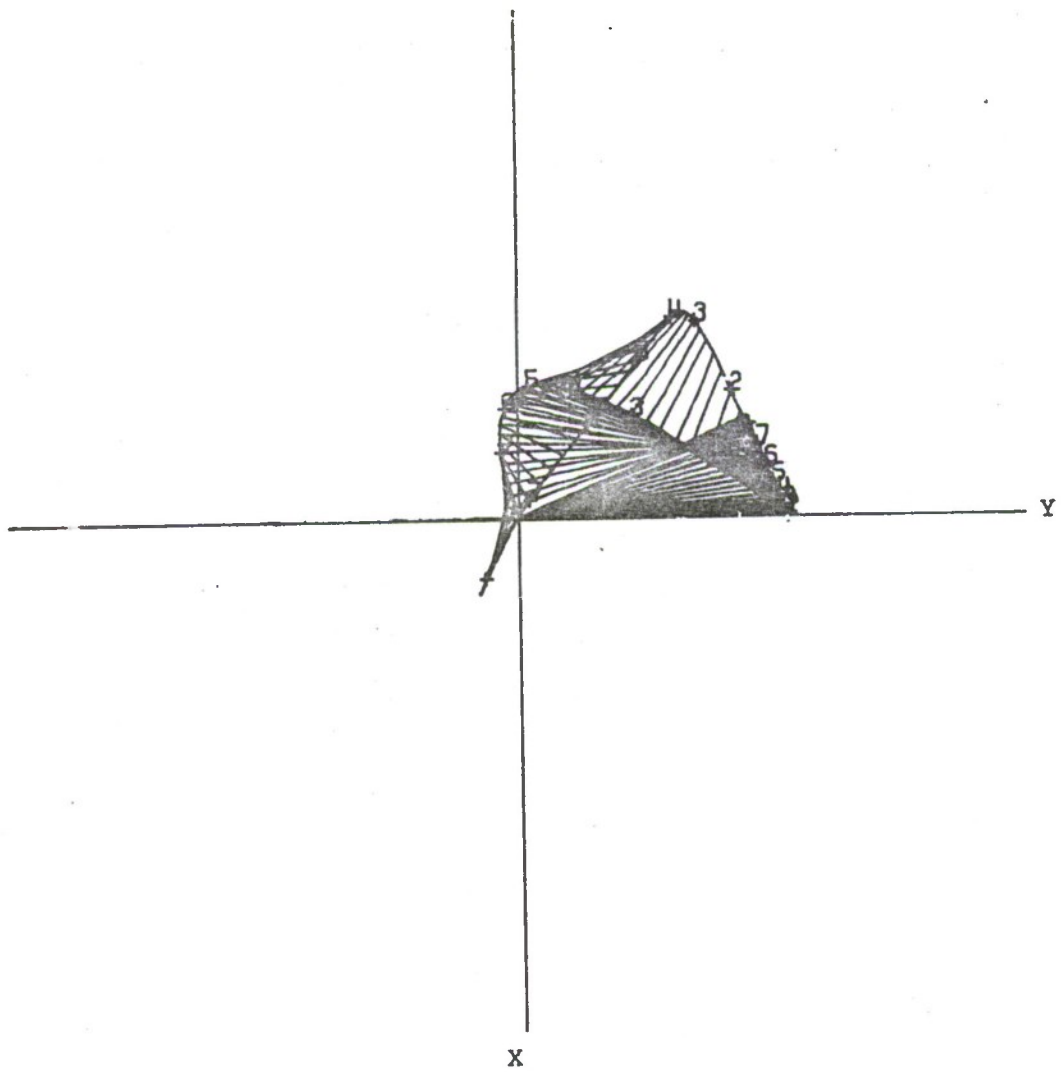

Ic-8.3. X-Y projection.

APPENDIX IIa. SAMPLE PROGRAM FOR STKMAN
(WALK PROGRAM)

DIMENSION BOD(5,4),CS(5,4,3),RP(3),R(5,5,3)	00010
RP(1)=0.	00020
RP(2)=0.	00030
RP(3)=0.	00040
TIME=0.	00050
KT=0	00060
T1=1.	00070
S=4.	00080
N=2	00090
CALL CCP1PL(0.1,0.1,-3)	00100
CALL BODY(BOD)	00110
CALL ZERO(CS)	00120
50 CONTINUE	00130
T=TIME	00140
CALL WACK(T,T1,S,N,CS)	00150
CALL POSIT(RP,CS,BOD,R)	00160
CALL POTT(R,RP,KT)	00170
KT=KT+1	00180
TIME=TIME+0.05	00190
IF(TIME.GT.2.) GO TO 1000	00200
GO TO 50	00210
1000 STOP	00220
END	00230

```

00240 SUBROUTINE WALK(T,T1,S,N,CS)
00250 DIMENSION CS(5,4,3)
00260 PI=3.1415926
00270 IF(T.GT.0.) GO TO 20
00280 EN=N
00290 S1=1.5
00300 S2=1.5
00310 S3=3.0
00320 H=SQRT(S3**2 - ((S/2)**2))
00330 DEL=S/8.
00340 15 PHI1=0.
00350 TH1=0.
00360 PHI2=0.
00370 TH2=0.
00380 GO TO 1000
00390 20 TEMP=T1/2.
00400 IF(T.GT.TEMP) GO TO 40
00410 TAU=T/T1
00420 XR=-S*TAU
00430 ZR=S3+ (H-S3)*(2*TAU)**2
00440 CALL ANGLE(XR,ZR,PHI1,TH1)
00450 XL=-XR
00460 ZL=ZR-8.*DEL*TAU*(.5-TAU)
00470 CALL ANGLE(XL,ZL,PHI2,TH2)
00480 GO TO 1000
00490 40 TEMP=(EN-.5)*T1
00500 IF(T.GE.TEMP) GO TO 80
00510 M=(2.*(T/T1)+1.)/2.
00520 EM=M
00530 TAU=(T-(2.*EM-1.)*T1/2.)/T1
00540 Z=H
00550 X=(S*(1.-2.*TAU))/2.
00560 CALL ANGLE(X,Z,PHI,TH)
00570 Z=Z-4.*DEL*TAU*(1.-TAU)

```

	X=-X	00580
	CALL ANGLE(X,Z,XI,ETA)	00590
	IF((M-(M/2)*2).EQ.1) GO TO 70	00600
60	CONTINUE	00610
	PHI1=PHI	00620
	TH1=TH	00630
	PHI2=XI	00640
	TH2=ETA	00650
	GO TO 1000	00660
70	PHI1=XI	00670
	TH1=ETA	00680
	PHI2=PHI	00690
	TH2=TH	00700
	GO TO 1000	00710
80	IF(T.GE.(EN*TI)) GO TO 15	00720
	TAU=(T-(FN-.5)*TI)/T1	00730
90	Z=H+ (S3-H)*(2.*TAU)**2	00740
	X=(S*(1.-2.*TAU))/2.	00750
	CALL ANGLE(X,Z,PHI,TH)	00760
	Z=Z-8.*DEL*TAU*(.5-TAU)	00770
	X=-X	00780
	CALL ANGLE(X,Z,XI,ETA)	00790
	IF(N.GT.((N/2)*2)) GO TO 70	00800
	GO TO 60	00810
	1000 CS(2,2,2) = PHI1	00820
	CS(2,3,1) = TH1	00830
	CS(2,4,1) = PI/2. - PHI1 + TH1	00840
	CS(3,2,2) = PI - PHI2	00850
	CS(3,3,1) = TH2	00860
	CS(3,4,1) = -PHI2 + TH2 + PI/2.	00870
	RETURN	00880
	END	00890

```

SUBROUTINE ANGLE(X,Z,PHI,TH)
CTH = (X**2 + Z**2 - 4.5)/4.5
TH=ARCOS(CTH)
STH=SIN(TH)
T1= X*(1.+CTH)+Z*STH
T2= Z*(1.+CTH) - X*STH
PHI=ATAN2(T1,T2)
RETURN
END
00900
00910
00920
00930
00940
00950
00960
00970
00980

```

```

SUBROUTINE BODY(BOD)
DIMENSION BOD(5,4)
BOD(1,1) = 0.5
BOD(1,2) = 1.5
BOD(1,3) = .25
BOD(1,4) = .75
DO 10 K=2,3
BOD(K,1) = .5
BOD(K,2) = 1.5
BOD(K,3) = 1.5
BOD(K,4) = 0.5
10 CONTINUE
DO 20 L=4,5
BOD(L,1) = .75
BOD(L,2) = 1.
BOD(L,3) = 1.
BOD(L,4) = 0.5
20 CONTINUE
RETURN
END
00990
01000
01010
01020
01030
01040
01050
01060
01070
01080
01090
01100
01110
01120
01130
01140
01150
01160
01170
01180

```

SUBROUTINE ZERO(R)	01190
DIMENSION R(5,4,3)	01200
PI=3.1415926	01210
DO 10 KK=1,5	01220
DO 10 KL=1,4	01230
DO 10 KM=1,3	01240
10 R(KK,KL,KM)=0.	01250
R(2,1,1) = PI/2.	01260
R(2,2,1) = PI/2.	01270
R(2,3,2) = (3.*PI)/2.	01280
R(2,3,3) = PI/2.	01290
R(2,4,1) = PI/2.	01300
R(2,4,2) = PI/2.	01310
R(3,1,1) = PI/2.	01320
R(3,1,2) = PI	01330
R(3,1,3) = PI	01340
R(3,2,1) = PI/2.	01350
R(3,2,2) = PI	01360
R(3,2,3) = PI	01370
R(3,3,2) = (3.*PI)/2.	01380
R(3,3,3) = PI/2.	01390
R(3,4,1) = PI/2.	01400
R(3,4,2) = PI/2.	01410
R(4,1,1) = PI/2.	01420
R(4,2,1) = PI/2.	01430
R(5,1,1) = PI/2.	01440
R(5,1,2) = PI	01450
R(5,1,3) = PI	01460
R(5,2,1) = PI/2.	01470
R(5,2,2) = PI	01480
R(5,2,3) = PI	01490
RETURN	01500
END	01510

```

SUBROUTINE POSIT(RP,CS,BND,R)
DIMENSION RP(3),CS(5,4,3),BND(5,4),R(5,5,3),A(3,3),B(3,3),C(3,3),
1 TB(3,3)
DO 160 K=1,5
IF(K-3)10,10,60
10 DO 20 I=1,3
20 R(K,I)=RP(I)
DO 50 N=1,3
DO 50 M=1,3
IF(N-M)30,40,30
30 B(N,M)=0.
GO TO 50
40 B(N,M)=1.
50 CONTINUE
GO TO 90
60 DO 70 I=1,3
70 R(K,I)=R(I,3,I)
DO 80 N=1,3
DO 80 M=1,3
80 B(N,M)=R(N,M)
90 DO 160 J=2,5
L=J-1
THETA=CS(K,L,I)
PHI=CS(K,L,2)
PSI=CS(K,L,3)
CALL ORIENT(A,THETA,PHI,PSI)
DO 100 N=1,3
DO 100 M=1,3
C(N,M)=0.
DO 100 NS=1,3
100 C(N,M)=C(N,M)+B(N,NS)*A(NS,M)
DO 110 N=1,3
DO 110 M=1,3
110 B(N,M)=C(N,M)
IF(K-1)150,120,150
120 IF(J-3)150,130,150
130 DO 140 N=1,3
DO 140 M=1,3
140 TB(N,M)=B(N,M)
150 DO 160 I=1,3
160 R(K,J,I)=R(K,J-1,I)+BND(K,L)*B(I,3)
RETURN
END
01520
01530
01540
01550
01560
01570
01580
01590
01600
01610
01620
01630
01640
01650
01660
01670
01680
01690
01700
01710
01720
01730
01740
01750
01760
01770
01780
01790
01800
01810
01820
01830
01840
01850
01860
01870
01880
01890
01900
01910
01920
01930
01940

```

```
01950
SUBROUTINE ORIENT(A,THETA,PHI,PSI)
01960
DIMENSION A(3,3)
01970
CTHETA=COS(THETA)
01980
STHETA=SIN(THETA)
01990
CPHI=COS(PHI)
02000
SPHI=SIN(PHI)
02010
CPSI=COS(PSI)
02020
SPSI=SIN(PSI)
02030
A(1,1)=CPSI*CPHI-CTHETA*SPHI*SPSI
02040
A(1,2)=-SPSI*CPHI-CTHETA*SPHI*CPSI
02050
A(1,3)=STHETA*SPHI
02060
A(2,1)=CPSI*SPHI+CTHETA*CPhi*SPSI
02070
A(2,2)=-SPSI*SPHI+CTHETA*CPhi*CPSI
02080
A(2,3)=-STHETA*CPhi
02090
A(3,1)=STHETA*SPSI
02100
A(3,2)=STHETA*CPSI
02110
A(3,3)=CTHETA
02120
RETURN
02130
END
```

	SUBROUTINE PRINT (R)	02140
	DIMENSION R(5,5,3)	02150
100	FORMAT (3F7.3,2X,3F7.3,2X,3F7.3,2X,3F7.3,2X,3F7.3/)	02160
	WRITE(6,100) (((R(K,L,M),M=1,3),L=1,5),K=1,5)	02170
	RETURN	02180
	END	02190
	SUBROUTINE POTT(R,RP,KT)	02200
	DIMENSION X(7),Y(7),Z(7),R(5,5,3),RP(3)	02210
	X(6) = 0.	02220
	Y(6) = 0.	02230
	Z(6) = 0.	02240
	X(7) = 2.5	02250
	Y(7) = 2.5	02260
	Z(7) = 2.5	02270
	AT=KT+1	02280
	CALL CCP3NR(1.2,2,0.35,AT,0.0,-1)	02290
	CALL CCP1PL(1.5,7.33,-3)	02310
	DO 1053 KSO=1,5	02320
	DO 1052 KJO=1,5	02330
	X(KJO) = R(KSO,KJO,1) - RP(1)	02340
	Y(KJO) = R(KSO,KJO,2) - RP(2)	02350
	Z(KJO) = R(KSO,KJO,3) - RP(3)	02360
1052	CONTINUE	02370
	CALL LINE(X,Z,5,1,1,03)	02380
	CALL CCP1PL(0.0,-3.0,-3)	02390
	CALL LINE(Y,Z,5,1,1,03)	02400
	CALL CCP1PL(0.0,-3.0,-3)	02410
	CALL LINE(X,Y,5,1,1,03)	02420
	CALL CCP1PL(0.0, 6.0,-3)	02430
1053	CONTINUE	02440
	CALL CCP1PL(0.5,-7.33,-3)	02450
	RETURN	02460
	END	02460

APPENDIX IIb. SAMPLE PLOTS FOR STKMAN

BLANK PAGE

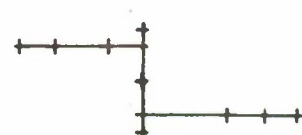
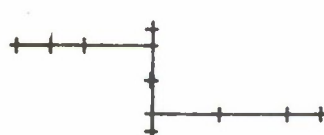
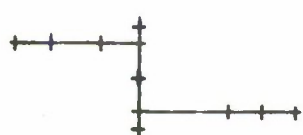
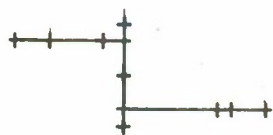
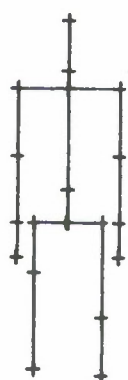
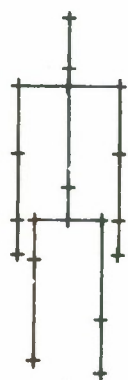

28

29

30

31

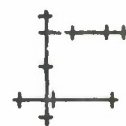
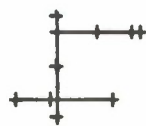
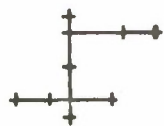

16

17

18

19

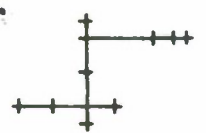
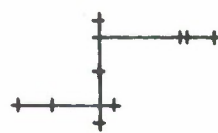
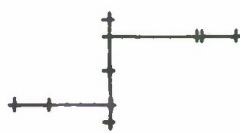
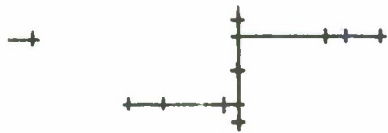
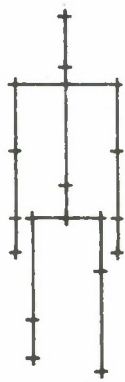
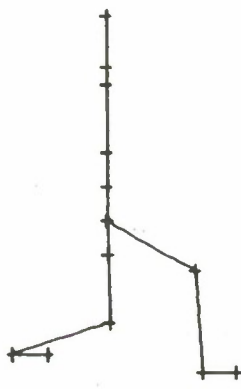
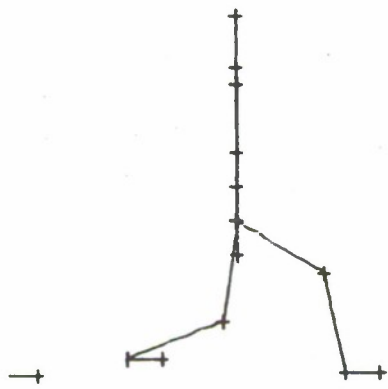

12

13

14

15

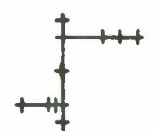
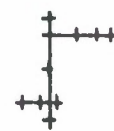
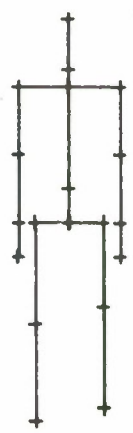
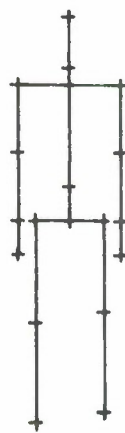
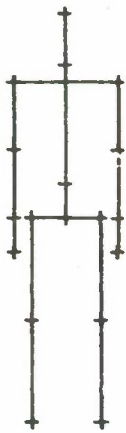

0

1

2

3

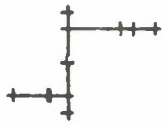
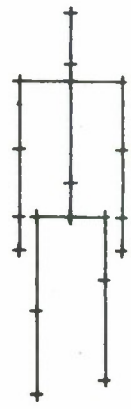
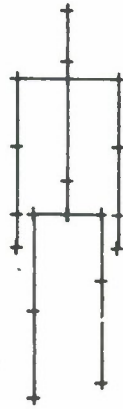
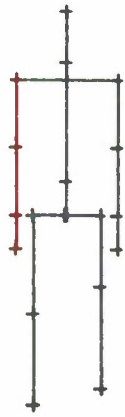
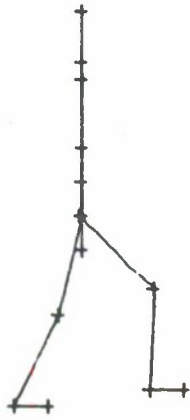

4

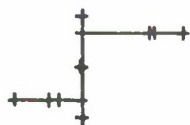

5

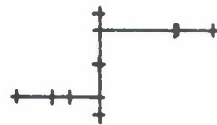

6



7

165

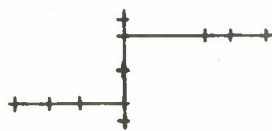
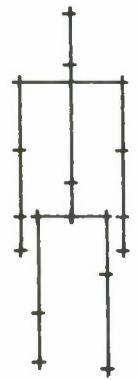
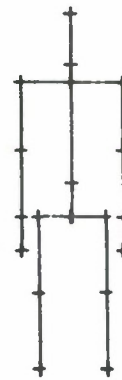
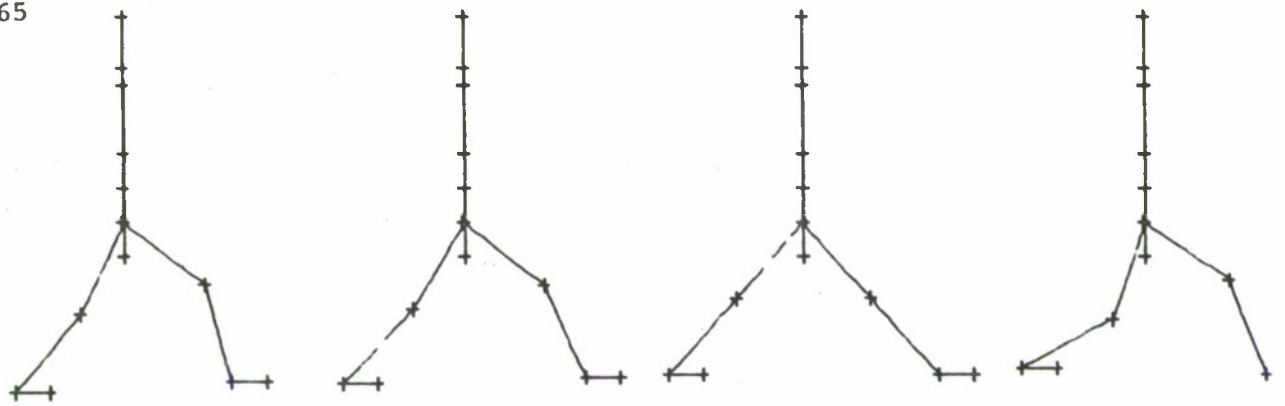

8

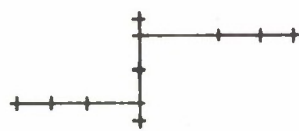

9



10

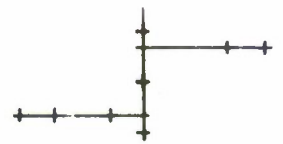

11

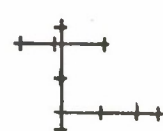
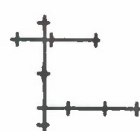
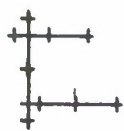
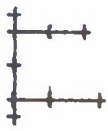
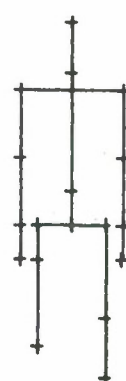
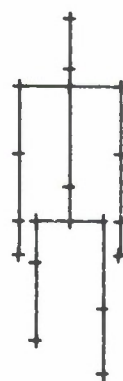
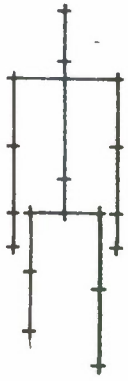

20

21

22

23

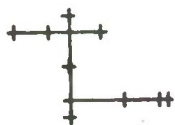
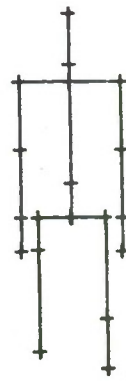
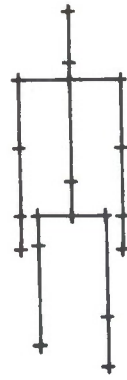
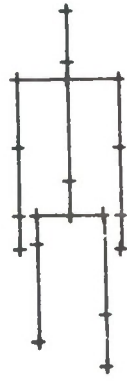
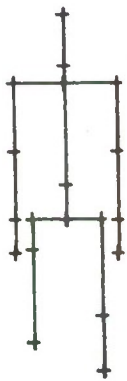
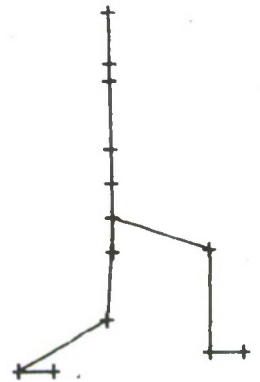

24



25

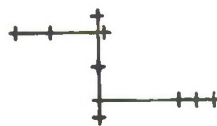

26

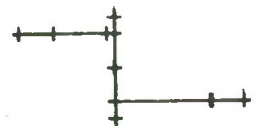

27

UNCLASSIFIED

Security Classification

DOCUMENT CONTROL DATA - R&D		
<i>(Security classification of title, body of abstract and indexing annotation must be entered when the overall report is classified)</i>		
1. ORIGINATING ACTIVITY (Corporate author) University of Illinois Biological Computer Laboratory Urbana, Illinois 61801		2a. REPORT SECURITY CLASSIFICATION UNCLASSIFIED 2b. GROUP
2. REPORT TITLE NOTATION OF MOVEMENT		
4. DESCRIPTIVE NOTES (Type of report and inclusive dates) scientific; ; final		
5. AUTHOR(S) (Last name, first name, initial) Eshkol, Noa; Melvin, Peter; Michl, Jean; Von Foerster, Heinz; Wachmann, Abraham		
6. REPORT DATE February 15, 1970	7a. TOTAL NO. OF PAGES 167	7b. NO. OF REFS 11
8a. CONTRACT OR GRANT NO. DA-ARO-D-31-124-G998	8b. ORIGINATOR'S REPORT NUMBER(S) Final Report (DA-ARO)	
a. PROJECT AND TASK NO. 7875-RT	9a. OTHER REPORT NO(S) (Any other numbers that may be assigned this report)	
c.		
d.		
10. AVAILABILITY/LIMITATION NOTICES Distribution of this document is unlimited.		
11. SUPPLEMENTARY NOTES		12. SPONSORING MILITARY ACTIVITY Army Research Office-Durham Box CM, Duke Station Durham, North Carolina 27706
13. ABSTRACT First, the basic principles of a notation of bodily movements as developed by Noa Eshkol and Abraham Wachmann are summarized. The syntactic elements of this notation are then translated into equations of motion in a set of Cartesian coordinate systems each of which is associated with a movable part of the body. Hence, by a cascade of transforms, any desired (and executable) movement is now describable. A computer program has been written which carries out these transformations, thus, any movement prescribed by a sequence of symbols in Eshkol-Wachmann notation can now be represented by the appropriate trajectories which, in this program, are printed out with a CALCOMP plotter as projections into the three principal planes, the XY-plane, the YZ-plane and the ZX-plane. Numerous illustrations exemplify the rich possibilities of an algorithm which translates symbolic commands into effective movements.		

DD FORM 1473
1 JAN 64

UNCLASSIFIED

Security Classification

UNCLASSIFIED

Security Classification

14. KEY WORDS	LINK A		LINK B		LINK C	
	ROLE	WT	ROLE	WT	ROLE	WT
Body Movements Notation Movement Notation Translation Algorithms for Movements Computer Representation of Movements Kinematic Models of Body Movements						
INSTRUCTIONS						
<p>1. ORIGINATING ACTIVITY: Enter the name and address of the contractor, subcontractor, grantee, Department of Defense activity or other organization (<i>corporate author</i>) issuing the report.</p> <p>2a. REPORT SECURITY CLASSIFICATION: Enter the overall security classification of the report. Indicate whether "Restricted Data" is included. Marking is to be in accordance with appropriate security regulations.</p> <p>2b. GROUP: Automatic downgrading is specified in DoD Directive 5200.10 and Armed Forces Industrial Manual. Enter the group number. Also, when applicable, show that optional markings have been used for Group 3 and Group 4 as authorized.</p> <p>3. REPORT TITLE: Enter the complete report title in all capital letters. Titles in all cases should be unclassified. If a meaningful title cannot be selected without classification, show title classification in all capitals in parentheses immediately following the title.</p> <p>4. DESCRIPTIVE NOTES: If appropriate, enter the type of report, e.g., interim, progress, summary, annual, or final. Give the inclusive dates when a specific reporting period is covered.</p> <p>5. AUTHOR(S): Enter the name(s) of author(s) as shown on or in the report. Enter last name, first name, middle initial. If military, show rank and branch of service. The name of the principal author is an absolute minimum requirement.</p> <p>6. REPORT DATE: Enter the date of the report as day, month, year, or month, year. If more than one date appears on the report, use date of publication.</p> <p>7a. TOTAL NUMBER OF PAGES: The total page count should follow normal pagination procedures, i.e., enter the number of pages containing information.</p> <p>7b. NUMBER OF REFERENCES: Enter the total number of references cited in the report.</p> <p>8a. CONTRACT OR GRANT NUMBER: If appropriate, enter the applicable number of the contract or grant under which the report was written.</p> <p>8b, 8c, & 8d. PROJECT NUMBER: Enter the appropriate military department identification, such as project number, subproject number, system numbers, task number, etc.</p> <p>9a. ORIGINATOR'S REPORT NUMBER(S): Enter the official report number by which the document will be identified and controlled by the originating activity. This number must be unique to this report.</p> <p>9b. OTHER REPORT NUMBER(S): If the report has been assigned any other report numbers (<i>either by the originator or by the sponsor</i>), also enter this number(s).</p> <p>10. AVAILABILITY/LIMITATION NOTICES: Enter any limitations on further dissemination of the report, other than those imposed by security classification, using standard statements such as:</p> <p>(1) "Qualified requesters may obtain copies of this report from DDC."</p> <p>(2) "Foreign announcement and dissemination of this report by DDC is not authorized."</p> <p>(3) "U. S. Government agencies may obtain copies of this report directly from DDC. Other qualified DDC users shall request through _____."</p> <p>(4) "U. S. military agencies may obtain copies of this report directly from DDC. Other qualified users shall request through _____."</p> <p>(5) "All distribution of this report is controlled. Qualified DDC users shall request through _____."</p> <p>If the report has been furnished to the Office of Technical Services, Department of Commerce, for sale to the public, indicate this fact and enter the price, if known.</p> <p>11. SUPPLEMENTARY NOTES: Use for additional explanatory notes.</p> <p>12. SPONSORING MILITARY ACTIVITY: Enter the name of the departmental project office or laboratory sponsoring (<i>paying for</i>) the research and development. Include address.</p> <p>13. ABSTRACT: Enter an abstract giving a brief and factual summary of the document indicative of the report, even though it may also appear elsewhere in the body of the technical report. If additional space is required, a continuation sheet shall be attached.</p> <p>It is highly desirable that the abstract of classified reports be unclassified. Each paragraph of the abstract shall end with an indication of the military security classification of the information in the paragraph, represented as (TS), (S), (C), or (U).</p> <p>There is no limitation on the length of the abstract. However, the suggested length is from 150 to 225 words.</p> <p>14. KEY WORDS: Key words are technically meaningful terms or short phrases that characterize a report and may be used as index entries for cataloging the report. Key words must be selected so that no security classification is required. Identifiers, such as equipment model designation, trade name, military project code name, geographic location, may be used as key words but will be followed by an indication of technical context. The assignment of links, rules, and weights is optional.</p>						

UNCLASSIFIED

Security Classification

END

DATE

FILMED

5-14-70