

AD704605

MATHEMATICAL RESEARCH AND
COMPUTER ORIENTED
ATMOSPHERIC STUDIES

by

Donald J. Armstrong
Raymond J. Arsenault

Carolyn M. Mandell
Alan P. Truesdale

Analysis & Computer Systems, Inc.
Building 6
Second Avenue
Northwest Park
Burlington, Massachusetts 01803

Contract No. F19628-69-C-0095

Final Report

REPORTING PERIOD: December 1968 through December 1969

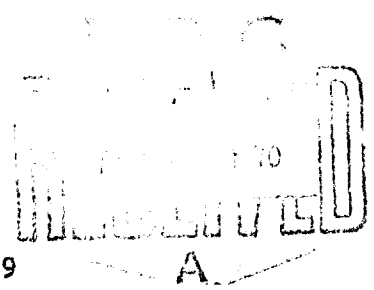

Contract Monitor: Vincent J. Mazzio, Analysis and Simulation Branch

This document has been approved for public
release and sale; its distribution is unlimited.

Prepared for

AIR FORCE CAMBRIDGE RESEARCH LABORATORIES
OFFICE OF AEROSPACE RESEARCH
UNITED STATES AIR FORCE
BEDFORD, MASSACHUSETTS 01730

Reproduced by the
CLEARINGHOUSE
for Federal Scientific & Technical
Information Springfield Va. 22151

1

86

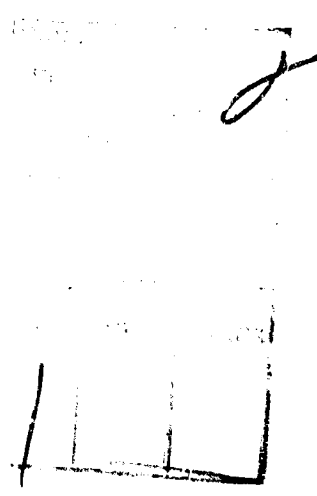

Qualified requestors may obtain additional copies from the Defense Documentation Center. All others should apply to the Clearinghouse for Federal Scientific and Technical Information.

MATHEMATICAL RESEARCH AND
COMPUTER ORIENTED
ATMOSPHERIC STUDIES

by

Donald J. Armstrong
Raymond J. Arsenault

Carolyn M. Mandell
Alan P. Truesdale

Analysis & Computer Systems, Inc.
Building 6
Second Avenue
Northwest Park
Burlington, Massachusetts 01803

Contract No. F19628-69-C-0095

Final Report

REPORTING PERIOD: December 1968 through December 1969

Contract Monitor: Vincent J. Mazzio, Analysis and Simulation Branch

This document has been approved for public
release and sale; its distribution is unlimited.

Prepared for

AIR FORCE CAMBRIDGE RESEARCH LABORATORIES
OFFICE OF AEROSPACE RESEARCH
UNITED STATES AIR FORCE
BEDFORD, MASSACHUSETTS 01730

ABSTRACT

This report is the concluding scientific report to record the status and progress of Scientific Analytical Investigations, the preparation of Computer Programs, Data Reduction, and the development of mathematical and computer techniques in support of Environmental Research and other various aspects of the physical sciences concerning the upper atmosphere.

During the year covered by this report, the 20 completed programs ranged in complexity and size from conversion of programs from one language or computer system to another, to analysis and development of a large system of analytical programs.

FOREWORD

These computer programs are the results of analytical research performed for:

The Analysis and Simulation Branch (CRMCA)

Computation Center AFCRL

Air Force Cambridge Research Laboratories

Bedford, Massachusetts 01730

The computer programs contained in this report may be obtained from the above organization, upon request by referencing the appropriate project number and problem number listed at the end of each program description.

TABLE OF CONTENTS

SECTION	PAGE
ABSTRACT	i
FOREWORD	111
1 INTRODUCTION	1-1
2 SAGAMORE HILL EDIT SYSTEM (EDSYS)	2-1
3 SURFACE WAVE PROPAGATION	3-1
4 ATMOSPHERIC TRANSMITTANCE	4-1
5 FAIL-SAFE	5-1
6 FOURIER SPECTROSCOPY	6-1
7 SPACE-CHARGE LIMITATIONS OF SECONDARY ELECTRON EMISSION CURRENTS IN SINGLE AND DOUBLE DIODES	7-1
8 CONTRIBUTORS	8-1
9 REFERENCES	9-1

SECTION 1

INTRODUCTION

This report documents the efforts under subject contract.

Each program documented herein describes what was done rather than a detailed program writeup.

Upon request, a complete program description may be made available to interested parties (see FOREWORD). The program descriptions are lengthy and very detailed, and may be used to follow the complete flow and operation of each program.

SECTION 2

SAGAMORE HILL EDIT SYSTEM (EDSYS)

At the AFCRL Radio Astronomy Branch Radio Observatory at Sagamore Hill, Hamilton, Mass., there are four major installations (1) the Solar Observatory (2) the 150' Radio Telescope, (3) the Satellite Building and (4) the 84' Radio Telescope. At each of these installations many different experiments and observations are performed resulting in a variety of data. Most of the data accumulated is recorded in two forms - strip chart recordings, and magnetic tape. The magnetic tape data is in analog form. To process and analyze this data on a digital computer it is necessary that the analog data be digitized. At the Sagamore Hill facility this digitizing is accomplished by the Digital Equipment Corporation (DEC) PDP-9 data processing system. This PDP-9 installation digitizes all analog data which is destined for computer processing, into a standard digital tape format. By utilizing one standard format, regardless of the data, standard programming procedures are possible, thus greatly reducing the effort required to implement follow-on data processing and analysis.

1. System Description

The Sagamore Hill Edit System (EDSYS) allows the user several means by which he may further prepare his data, thus reducing the time and effort required to program and process it on a large scale computer system.

EDSYS consists of 28 interrelated programs co-located in the PDP-9 core memory. It will read, restructure and display the data on a cathode ray tube (CRT) display. Once the data is displayed the user may manipulate the displayed data for a better presentation. This manipulation in no way

changes the data, only its presentation. The user may then use the system to calibrate, edit or reduce the data and record his results on an output tape. By proper use of EDSYS the user may also gather selected files of data from different tapes onto one tape or conversely, scatter several files from one tape onto several tapes. He may also gather whole or parts of several files of data into one file.

EDSYS requires magnetic tape input in the Sagamore Hill digitizing system format. The data is arranged in files. Each file is composed of a header block, an arbitrary number of data blocks, and an end-of-file mark. The last file on the tape is followed by a series of consecutive end-of-file marks to signal logical end-of-tape.

When EDSYS is first loaded and at other appropriate points throughout the system's operation, the user may position the input or output tapes. This is accomplished by responding to commands printed on the teletype by EDSYS. (The teletype and CRT display are the man-machine interfaces for EDSYS.)

Once the tapes have been positioned to the beginning of the desired file, EDSYS will read the header record from the input tape. The header record is always the first record in a file and is 78 words long arranged as follows:

<u>Word(s) (in octal)</u>	<u>TABLE 1</u>	<u>Contents</u>
1-2		Code used for PDP-9 Magnetic Tape Handler
3-5		Alphanumeric word "HEADER" in ASR/KRS Teletype Code (ASCII); two characters per word.

<u>Word(s) (in octal)</u>	<u>Contents</u>
6	Word of zeroes; separates above from label
7-37	50 ₁₀ characters used as label; ASR/KSR Teletype code (ASCII); two characters per word.
40-53	Analog tape channel numbers.
54	Number of channels digitized.
55	Analog tape channel number of timing track.
56	Number of minor time cycles per second.
57	Sample rate: number of minor time cycles between samples.
60-63	Start time: Day, Hours, Min., and Sec.
64-65	Start time: TCT (Time Code Translator) packed format
66-71	End time: Day, Hours, Min., and Sec.
72-73	End time: TCT packed format
74	Used to indicate a Calibrated File.

Note: There are 18 bits per word in the PDP-9.

The header record is identified by the first four words which contain the 8 bit ASCII codes for "HEADER blank". These 8 bit codes are contained in 9 bits so that each ASCII character occupies exactly half of an 18 bit PDP-9 word.

Whenever EDSYS reads and identifies the first record in the file as a header record, it will print the header record contents. This consists of the label, whether or not the file is calibrated, the channel numbers, the minor time cycles per second, the sample rate, and finally the start and stop times.

The file label is composed of a maximum of sixty-two 8 bit ASCII characters. If the label contains less than 62 characters the unused character positions contain blanks (zeros).

The indication as to whether the file is calibrated or not is contained in the last word of the record. If the contents of this word equal zero the file is not calibrated. If the contents of this word equal one the file is calibrated.

The channel numbers (1-12) are contained in the same order as they appear in each data set. This order may not be numerical.

The minor time cycles per second represent the smallest unit of time in the time code channel of the analog tape. In the Sagamore Hill system there are two possible values. For IRIG-B time codes it will be 1000 cycles per second. For IRIG-C time codes it will be 100 cycles per second.

The sample rate is the number of minor time cycles between each data set and is represented in the header record type out as the number of data sets per second and minute of time on the input file.

The start and stop times are the major times that digitizing of the data in this file was started and requested to stop. These times may not be strictly correct for several reasons. The times are inserted into the header record before digitizing takes place and are never changed afterwards. The operator may have terminated digitizing manually, the data may have been edited by a previous run through EDSYS or data may have been appended to the file. Any one of the foregoing reasons could render these times inaccurate.

A word about the structure of a data block as used by EDSYS, is in order at this time. The data block is a magnetic tape record 1000_8 words long.

The first two words are code words used by the PDP-9 Magnetic Tape Handler. The third word is a count of the data sets contained in the block. Following the data set count is the time of recording in two-word TCT (Time Code Translator) packed format for the first data set. A data set consists of data points of the channels sampled in parallel, packed two data points to a word, and preceded by the number of minor time cycles since the last TCT time. Data sets are sequential until a new TCT time is encountered. The TCT time, preceded by a word of 777777, is inserted between data sets. Fractions of a data set are not permitted within a data block. Unused words remaining at the end of a data block are ignored.

A data point is an 8 bit sample value from the A (analog) to D (digital) converter which is stored, left justified, in 9 bits. The rightmost, or low order, bit is used by EDSYS to indicate data points that are to be ignored either for display purposes or follow-on processing. To obtain a sequential number, the most significant (leftmost) bit must be complimented. After complimenting, a "0" 8 bit value represents a peak (+1.4 volts) on a chart recorder and a 255₈ 8 bit value represents a null (-1.4 volts).

EDSYS has the ability to eliminate channels of data from all data sets of an input file. When channels are eliminated from a data set the data is restructured to close up the gaps left by the eliminated channels. This is called restructuring.

The only words of a data set to be affected by restructuring are the data words. When restructuring takes place the unwanted channels are removed from all data sets and the gaps are closed up. This action takes place when data sets are being loaded into the display area of core memory (hereafter called the display buffers). All data sets written on the output

Data Block Format

Word	(octal)		
1		Code words for	Word Length = 18 bits
2		Handler	
3		Data Set Count	
4		TCT Packed	
5		Time	Data set
6		Minor time cycle count	
7		1st Channel 2nd Channel	
10		3rd Channel ignored	
11		Minor time cycle count	
12		1st Channel 2nd Channel	
13		3rd Channel ignored	
.		.	
.		.	
.		.	
n		Minor time cycle count	
n+1		1st Channel 2nd Channel	
n+2		3rd Channel ignored	
n+3		777777	
n+4		TCT Packed	
n+5		Time	
n+6		Minor time cycle count	
.		.	
.		.	
.		.	
775		1st Channel 2nd Channel	Not enough room for another data set
776		3rd Channel ignored	
777		ignored	
1000		ignored	

Example of data block for three channels.

Figure 1.

tape are written from the display buffers. Therefore, restructuring results in eliminating the unwanted channels from the data base so that they can never appear in the output file.

This restructuring is defined by the user just after accepting an input file and holds for the entire input file and any input files that are appended. Also the channel list in the header record of the output tape will be modified to reflect any restructuring.

The sample rate may be changed by teletype input after the header record contents have been printed, the input file has been accepted for processing and before data processing takes place. The specified sample rate will be in effect until an end of file mark is written on the output tape even if appending other files and will be reflected in the sample rate value in the output header record. This change in sample rate, if any, takes place at the same time as, but independent of, restructuring that is, when the data is moved into the display buffers.

The calibration mode of EDSYS allows the user to read, display and calibrate a file of data from a Sagamore Hill format tape, provided the input file has not been previously calibrated.

When data is collected, recorded on analog tape and digitized, the resulting digital values will lie within certain fixed limits. These digital value limits are 0 to 510 (decimal) in even numbered steps. In order to convert the digitized values back to meaningful values, the Calibration mode of EDSYS was developed.

When the data is initially recorded onto analog tape it should contain one or more sets of calibration curves per channel. These curves are two or more signal levels created by recording known measurement levels for a short period of time per level for each channel. By noting the time of recording these levels and the values of each level, the EDSYS user can display these levels and associate them with their original values. Once two to four of these associations or pairings of actual versus digitized values (hereafter called value-count pairs) have been made, EDSYS can calculate the four coefficients to a third order polynomial. This calculation is accomplished by solving four simultaneous equations in a matrix (A).

The matrix is loaded as follows where:

$$x_n = \text{IKNT}(n) = \text{digitized values}$$

$$y_n = \text{COM}(n) = \text{real values}$$

$$A_n = \text{COEF}(n) = \text{coefficients (unknowns)}$$

n goes from 1 to N. N must be in the range of 2 to 4. In the following example N = 4

$$N = \text{ICCCNT} = \text{number of entries in IKNT} + \text{COM}$$

A			
	2	3	
1	1	1	y ₁
2	2	2	y ₂
3	3	3	y ₃
4	4	4	y ₄

$$A_1 + A_2 x_1 + A_3 x_1^2 + A_4 x_1^3 = y_1$$

$$A_1 + A_2 x_2 + A_3 x_2^2 + A_4 x_2^3 = y_2$$

$$A_1 + A_2 x_3 + A_3 x_3^2 + A_4 x_3^3 = y_3$$

$$A_1 + A_2 x_4 + A_3 x_4^2 + A_4 x_4^3 = y_4$$

By Gauss's Elimination Method the matrix is reduced to the form:

A			
x_1	x_1^2	x_1^3	y_1
1	A_{22}	A_{23}	A_{24}
.	1	A_{33}	A_{34}
.	.	1	A_{44}

$$a_1 = y_1 - a_2x_1 - a_3x_1^2 - a_4x_1^3$$

$$a_2 = A_{24} - a_3A_{22} - a_4A_{23}$$

$$a_3 = A_{34} - a_4A_{33}$$

$$a_4 = A_{44}$$

By substitution, starting with A_4 and working back to A_1 , the various coefficients are easily found. These coefficients are then combined with the time of the first value-count pair, the channel number and the unit of measurement to make a calibration set. During the Calibration mode these sets are accumulated in the calibration block.

A Calibration block is 1000_8 (512_{10}) words long and consists of:

- A.) Magnetic Tape Handler information (two 18 bit words)
- B.) A series of calibration sets
- C.) Words containing -2 (w in twos complement form) to signal the end of the calibration set series.

A calibration set consists of:

- A.) Major time backed in TCT format which is:

1	2	3	4	5	6	7	8	9	10	11	12	13	14	15	16	17	18	bit #
Hunrds. of days		Tens of days			Units of days			0	Tens of Hours		Units of Hours			0	Word 1			
0	0	0	Tens of Minutes		Units of Minutes		Tens of Seconds		Units of Seconds		0	Word 2						

Major Time Format

Figure 2

B.) Four 7 bit ASCII (ASR/KSR Teletype code) characters of the Unit of Measure

(UofM) abbreviation and the Channel Number in the following format:

1	2	3	4	5	6	7	8	9	10	11	12	13	14	15	16	17	18	bit #
1st Character Code							2nd Character Code							3rd Char. Code			Word 1	
3rd (Cont.)				4th Character Code				Channel Number						Word 2				

7 Bit Packed ASCII Format
Figure 3

C.) Four coefficients to a 3rd order polynomial expressed in PDP-9 single precision floating point format which is:

1	2	3	4	5	6	7	8	9	10	11	12	13	14	15	16	17	18	bit #
Mantissa (low order end)									Exponent									Word 1
S	Mantissa (high order end)																Word 2	

PDP-9 Floating Point Format (Single Precision)
Figure 4

The floating-point representation of a binary number consists of two parts: the exponent and mantissa. The mantissa is a fraction with the binary point assumed to be positioned between the sign (A) bit and the most significant data bit. The mantissa is always stored in a normalized state; i.e., leading 0s are eliminated from the binary representation so that the high order bit is always a 1 (except for the value zero in which case both words contain all zeros). It is a 26 bit quantity in sign and magnitude notation and occupies the 9 high order bits of the first word and the 17 low order bits of the second word. The exponent represents the power of 2 by which the mantissa is multiplied to obtain the number's value for use in computation. It is a signed 9 bit integer in 2s complement notation and occupies the nine low order bits (bits 10-18) of the first word.

Word # (octal)	(Each word = 18 bits)								
1	Magnetic Tape								
2	Handler Words								
1st Calibration Set	Days (100's)	Days (10's)	Days (1's)	0	Hrs. (10's)	Hours (1's)	0	Major Time packed	
	0	0	0	Mins. (10's)	Mins. (1's)	Secs. (10's)	Secs. (1's)	In TCT format	
	1st char. U of M.		2nd char.		3rd			Unit of Measure	
	3rd		4th		Channel Number			& Channel Number	
	Mantissa (Low order)			Exponent				1st Coefficient	
	S	Mantissa (high order portion)						(a ₀)	
	-----							2nd Coefficient	
	-----							(a ₁)	
	-----							3rd Coefficient	
	-----							(a ₂)	
	-----							4th Coefficient	
	-----							(a ₃)	
	2nd Calibration Set	Major Time							
		Unit of Measure							
		1st Coefficient (a ₀)					Channel Number		
		2nd Coefficient (a ₁)							
3rd Coefficient (a ₂)									
4th Coefficient (a ₃)									
777776 ₈ (-2)									
777776 ₈ (-2)									
777776 ₈ (-2)									
777776 ₈ (-2)									
511	777776 ₈ (-2)								
512	777776 ₈ (-2)								

-2 indicates no more sets

Calibration Block
(contains 2 calibration sets)

Figure 5
2-11

When all the necessary calibration sets (up to 42) have been collected in the calibration block, it is recorded directly behind the header record in the output file. The data itself may then be copied or edited into the output file following the calibration block.

When a magnetic tape, which has been prepared at Sagamore Hill, is to be processed, the recommended procedure is as follows regarding calibrations. The header record is read and if the last word contains a one the next record will be a calibration record. If this is the case, the calibration record should be read into an area of core memory reserved for it. When it is desired to compute the actual value of a data point, the calibration block can be searched for a calibration set containing the desired channel number and the appropriate major time code. If the computer system doing this processing does not use the PDP-9 single precision floating point format for floating point values, the coefficient values in the calibration set will have to be converted to the proper format. The actual value of the data point can then be computed via a 3rd order polynomial as follows:

$$V = A_0 + A_1X + A_2X^2 + A_3X^3$$

where: V is the actual value of the data point $A_0, 1, 2, 3$ are the four coefficients in the calibration set.

X is the data point from the data set with its high order bit complimented.

All the values are expressed in the floating point format of the computer doing the processing.

Not only can the measured value be calculated in this standard manner but the Unit of Measure, expressed in 7 bit packed ASCII code, is also available. If the computer system doing the processing does not use the ASCII character codes, then the characters composing the Unit of Measure will have to be converted to the proper code.

Using this calibration system standardizes the data tapes and the methods used to process them, thus eliminating many individual subroutines and calibration tables. The variables necessary to convert the counts to meaningful data and the unit of measure to identify the value are co-resident with the data in a magnetic tape file, thus eliminating the need for calibration charts which have to be converted to some medium (usually punched cards) useable by the processing computer.

The Edit mode allows the user to read, display, cancel and append a file of data from a Sagamore Hill format tape. This file may be calibrated or not. If it is calibrated it can not be appended to any other file nor can any other file be appended to it. Appending consists of sequentially adding one or more files of input data to form one file of output data.

Cancelling may be one of two types - delete or ignore. Cancel-delete eliminates all the data in each channel, within a selected time period, from the output file. Cancel-ignore flags the data in selected channels, within a selected time period, but does not eliminate it from the output file.

The Reduction mode allows the user to read, display and reduce a file of data from a Sagamore Hill format tape. This input file may be calibrated or not.

Reducing data takes two forms in EDSYS. The first is the comment function. The other is the set function. Both functions can operate only in the reduction mode. Briefly, the comment function allows the user to record any comment which has been typed in through the teletype keyboard, to be recorded on the output tape in 7 bit packed ASCII format. The set function allows the operator to record single or multiple data points from any given input channel onto the output tape, along with the time and an optional 5 character typed in comment for each data point. The actual value and unit of measure may also be included with each data point, if the input data was calibrated.

The reduction mode allows the user to create an output tape of a somewhat flexible format, which he may interpret in any manner that is applicable to his particular problem.

Each comment block (record) on the output tape will be 256 words long and contain one comment or part of one comment, regardless of the length of the comment. Since there are 5 characters per word pair of 7 bit packed ASCII, one comment block is capable of containing 630 characters of comment. A comment can exceed 630 characters, however. If it does exceed 630 characters, EDSYS will keep filling the comment block and writing it onto the reduced output tape until an ALT MODE character is typed. EDSYS will then write the current comment block including the ALT MODE code, onto the reduced output tape.

The Reduced Output Tape will consist of a series of files. Each file will be a mixture of Comment Blocks and Data Blocks. It is suggested that each Reduced Tape be started with a Comment Block, but this is not necessary.

Series of Reduced Files

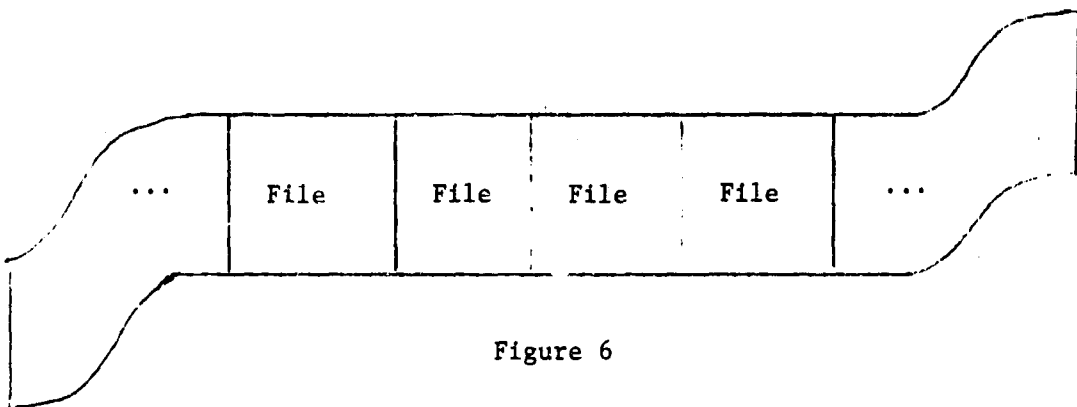

Figure 6

Reduced Tape File

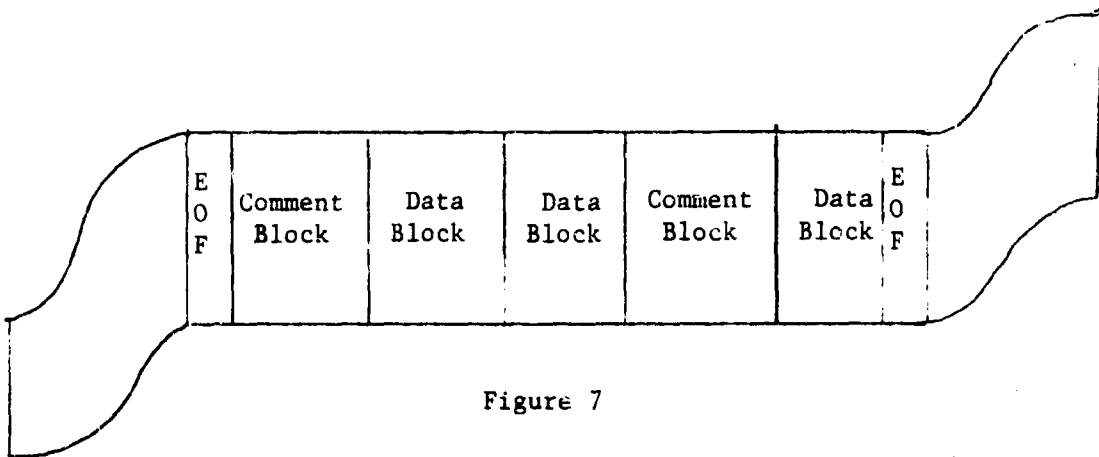
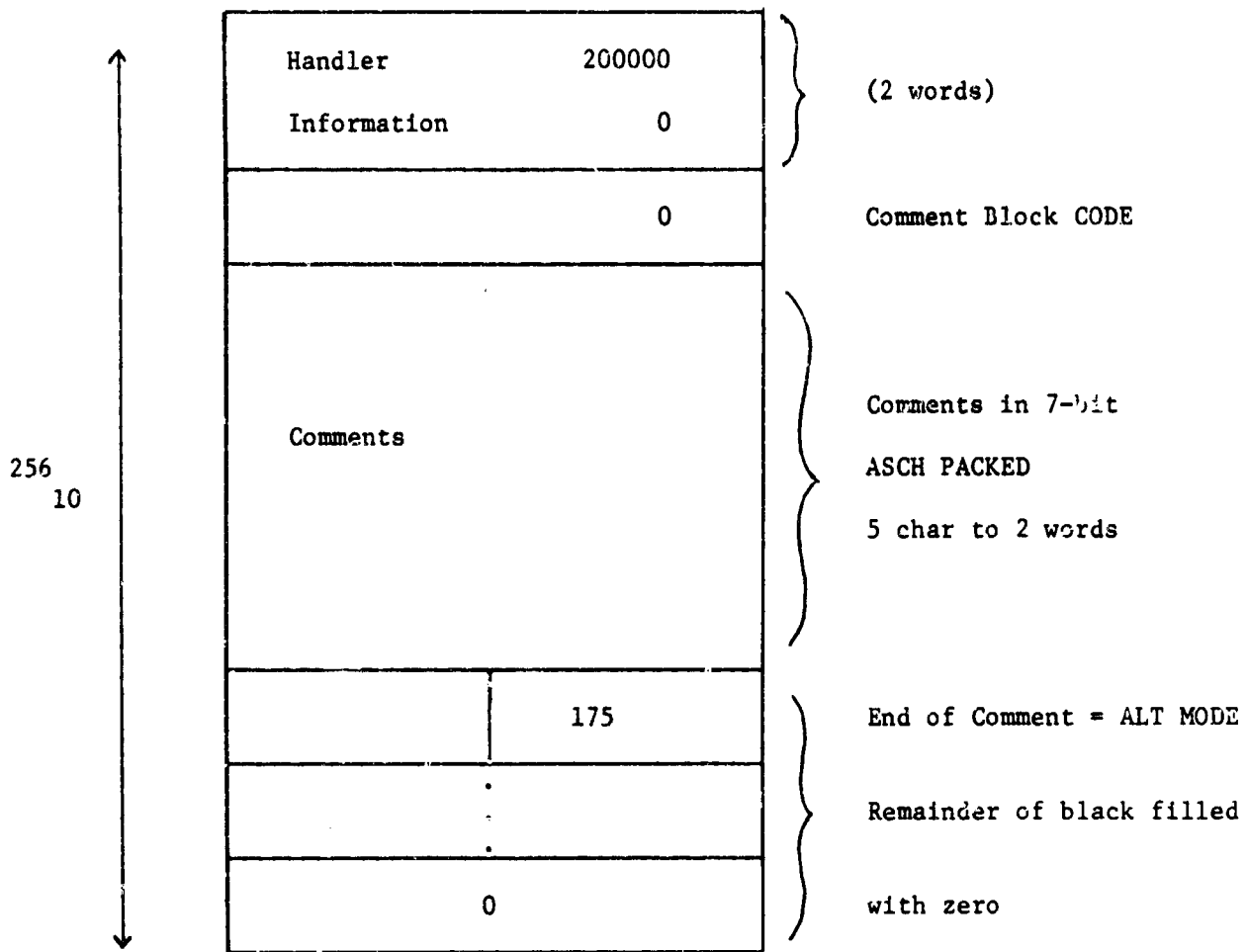

Figure 7

Comment Block



NOTE: ALT MODE (175) will signify the end of comments in the block.

The last word of the block is always zero.

Reduced Data Block

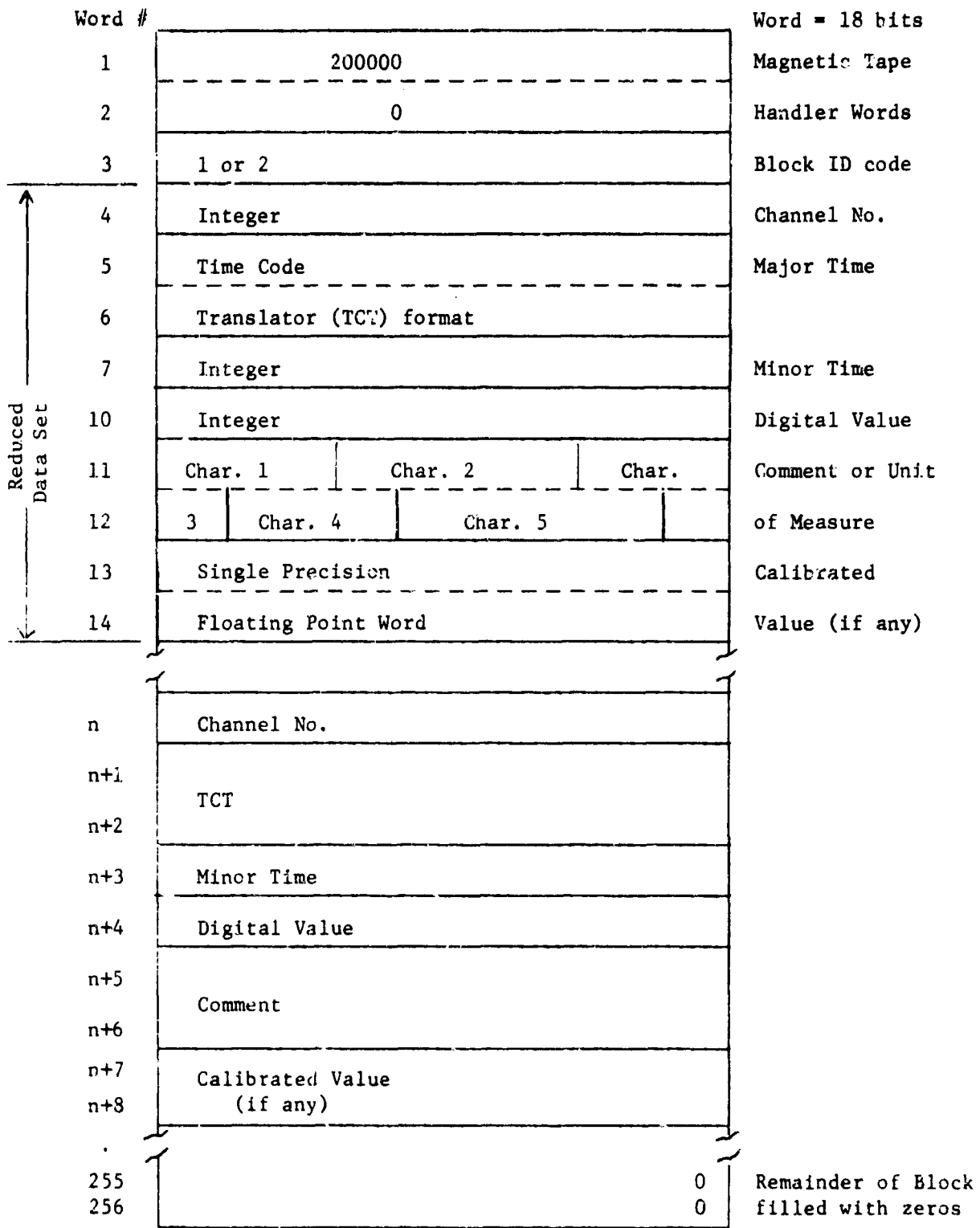

Reduced Data Set

NOTE: Block Identification Code: 1 = Non Calibrated Data
 2 = Calibrated Data

Figure 9

Each data block (record) on the output tape will be 256 words long and will usually contain 28 reduced data sets. It may contain less than 28 only if it is followed by a comment block or end-of-file mark. If a reduced data block does not contain 28 reduced data sets, the remainder of the block is filled with zeros.

Each reduced data set represents one data point and contains all the pertinent information about that point. If it is to be processed by a computer system which does not use 7 bit ASCII character codes or PDP-9 single precision floating point format then these items in the reduced data set must be converted to the applicable forms.

2. System Operation

The two major means of communication between the user and EDSYS are the teletype and the CRT display system. Since man can make mistakes, EDSYS provides several methods of error correction and prevention. One of the more basic methods is to limit the devices by which data can be added, changed, or deleted. In EDSYS the display actions available to the user cannot change the data base. Only the user commands entered through the teletype actually initiate data modification.

The user need not be concerned with the methods used by EDSYS to print messages to the user. However, the user should be aware of the means at his disposal for preventing his typing errors from being mis-interpreted by EDSYS. If EDSYS does not understand a user type-in, it will usually print an indication of this (i.e. a question mark and sound a bell) and allow him to retype his message.

Whenever EDSYS is ready to accept a message from the user it will print an asterisk (*) at the beginning of the current line. (There are

certain exceptions to this convention which will be explained later in this document.) The user may then type a message on the keyboard. To signal EDSYS that the message is complete, the user must type a carriage return. This is the standard termination for all messages typed by the user.

If the user types a wrong character he may use the rubout key. The rubout key is available for deleting the last character typed in a user's input message. A reverse slash is typed by the system for feedback. Thus, the line:

```
1 1012\ 12
```

will produce the line:

```
1 10 12
```

in the core memory image of the message. The rubout key will not alter anything before the beginning of the message. i.e. - XXX \\\ \\\ will result in a blank line in the core memory image. Each space and tab in the user's input is regarded as a single character and may be eliminated by the rubout key.

To erase an entire line from the core memory image, the user should hold the control key down and type U, (referred to as control U or ^U). The symbol (^ will be typed and the user may input a new line. The system will not cause a carriage return and line feed after printing the (^). Therefore, the user must start his new line immediately after the (^ since any carriage return typed by the user will result in message termination. If the typing head goes into the right hand margin and the user's message has not been completely typed-in, he must continue to type his message to completion, even though there will be overtyping at the end of the line.

Once a file has been accepted for processing, the channels to be processed defined, the sample rate set and the mode determined, EDSYS will fill the display buffers and display all the data in them on the display CRT. Each channel of data is displayed with the time (X) axis going from left to right in the increasing time direction and with the channel number time direction and with the channel number to the left of the X axis. The channels are displayed parallel to each other and separated for optimum viewing.

There are also two vertical lines extending across all channels. These lines are called verniers. They each have at their bases a short horizontal line, called a bar, for moving the verniers from side to side. The verniers are singularly used to point to individual data sets in the display buffers. In so doing a vernier will indicate one data point per channel at the same major and minor time for all channels. Used singularly they define data points and/or time of interest to the operator. Used together they define a segment of data covering the same period of time in each channel. They are used by the operator to indicate to EDSYS the data of interest to him. The verniers cannot overlap for if the operator attempts to move one vernier into the other, the second vernier will be "pushed" ahead of the one being moved. The left vernier is called the beginning (B) vernier and indicates the data points immediately in line with it or those immediately to the right of it, if it lies somewhere between two points. Likewise, the right or ending (E) vernier indicates those data points immediately in line with it or immediately to the left of it. In the Calibration mode there is only one vernier - the left or beginning (B) vernier.

There are also four dots arranged along the bottom of the display. These are for display manipulation in conjunction with the light pen and function like a push button. From left to right they are:

- A. The X Axis Select Dot
- B. The Contraction Dot
- C. The Expansion Dot
- D. The Paging Dot

The X Axis Select Dot is used to cancel an individual channel selection and select the X axis for expansion or contraction.

The Contraction Dot will contract the display along the Y axis of a selected channel or along the X axis for all channels if no channel is selected.

The Expansion Dot operates in the same manner as the Contraction Dot except that the display is expanded.

The Paging Dot is used to display the next "page" of data. Page of data is defined as that data which is currently displayed on the CRT. It may be all or part of the total data contained in the display buffers, depending upon the X axis expansion. The next page of data would be the data immediately following the displayed data, which replaces the data currently displayed.

By use of the following teletype commands, the user may display, at his option, any or all of the channels being processed. (In the following teletype command formats underlined characters are printed by EDSYS)

- * D Display all channels
- * D a,b,... Display channels a,b,...

The y-axis scales are reset to initial size with the display command.

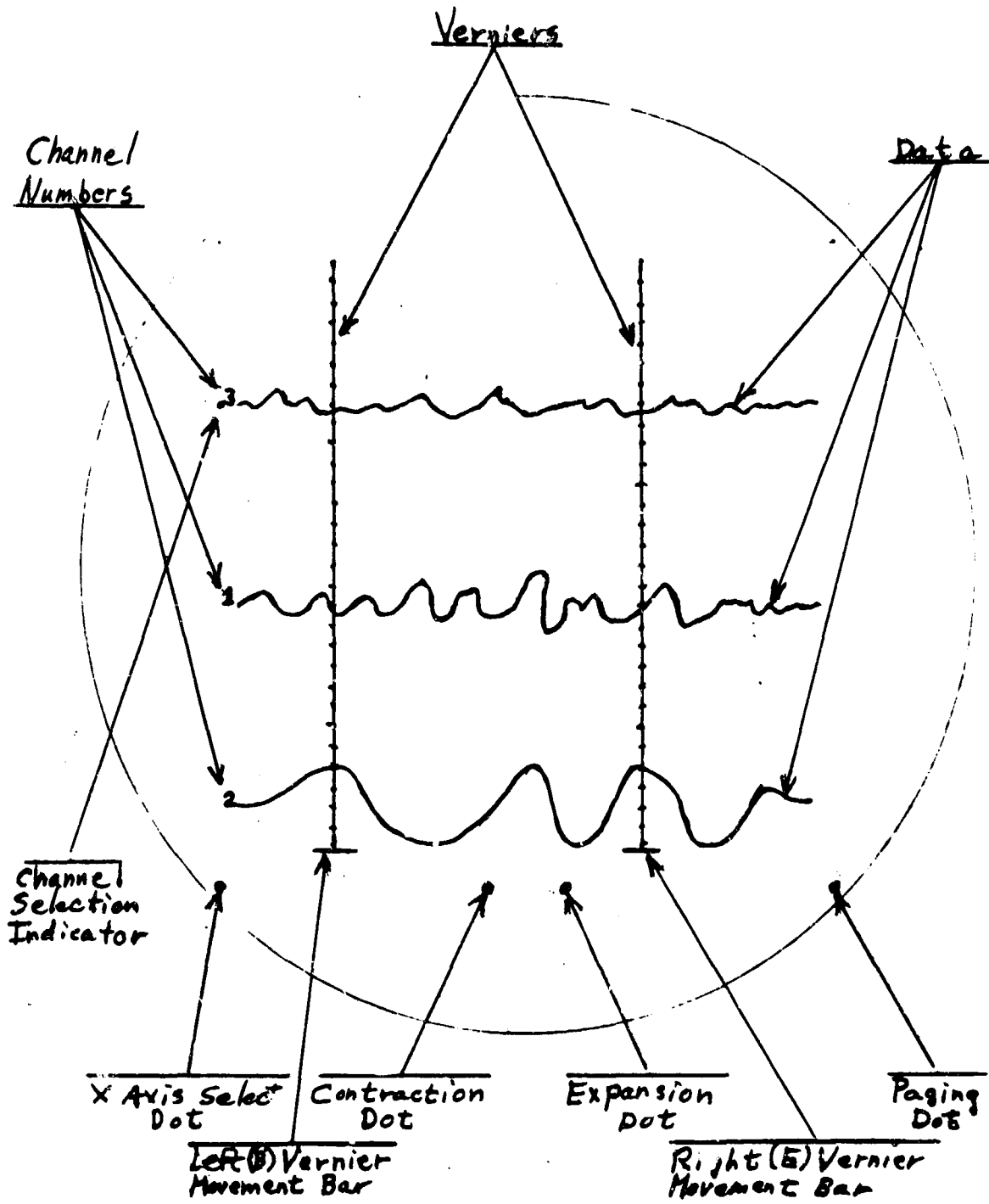

EDSYS Display of 3 Channels

Figure 10

The light pen is a photosensitive device which senses displayed points on the face of the CRT display. It uses a fiber optic light pipe and photomultiplier system equipped with a mechanical shutter, which prevents the sensing of unwanted information while positioning the pen.

In the EDSYS, the light pen is used to select individual channels or the X axis, to expand or contract the display, to move the verniers from side to side, and to cause the next page of data to be displayed.

The user may specify a channel for calibration, reduction, or scale change by pointing the light pen at the desired channel number and pressing the shutter on the light pen. A dot will appear to the left of the number as an indication that EDSYS has selected the desired channel. This action will deselect any other selected channel or the X (time) axis.

The user may select the time (X) axis for scale change (expansion/contraction) by pointing the light pen at the dot displayed in the lower left of the display. This dot is called the X Axis Select Dot. This action will also cancel the current channel selection.

The user may expand the value (y) axis of a light pen selected channel or the time (X) axis, whichever is selected, by pointing the light pen at the right center dot (the Expansion Dot) and depressing the mechanical shutter button on the light pen. Axis contraction can be accomplished in the same manner by use of the left center dot (the Contraction Dot). Sometimes the y axis changes will not be very evident because of a slow display refresh rate. The display refresh rate increases as the number of points to be displayed decreases. Thus, to observe a more rapid y axis expansion/contraction the following procedure is suggested:

- A. Light pen the X Axis Select Dot.
- B. Light pen the Expansion Dot and keep the shutter open till the X axis expands to maximum
- C. Light pen the channel number of the channel desired.
- D. Light pen the Expansion or Contraction dot, whichever is desired, and hold the shutter open until the desired expansion or contraction is obtained.
- E. Light pen the X Axis Select Dot and then the Contraction Dot to bring the X axis back to the expansion that is desired.

The verniers are moved by pointing the light pen at the horizontal bar at the base of the desired vernier, depressing the mechanical shutter and then "dragging" the vernier to the desired position. "Dragging" means moving the light pen left or right while holding the shutter button depressed and pointing at the bar. The vernier will follow the light pen to the desired position.

By pointing the light pen at the Paging Dot in the lower right hand corner of the display and then pressing the shutter button, EDSYS will display the next page of data. A small amount of overlap in the displayed data will be allowed for continuity if the display fills the CRT from left to right. The next page will always display the same channels at the same X and Y expansion as the previous page. No data is lost when paging in the EDIT mode as all data moved off the display to the left is eventually written on the output tape. The light pen can sense the Paging Dot only once per second so that there is no danger of over-running the desired page. Holding the shutter depressed will cause EDSYS to display a new page once every second.

By use of teletype commands the user has the facility to move into the data to some predetermined time set by the user. As EDSYS scans the input file for the time specified it may, at the user's option, copy the data onto the output file or cancel-delete the data which eliminates it from the output file or cancel-ignore the data which flags the data in the channels specified by the user and copies it onto the output file. This option is available in the Edit mode only. In the Calibrate or Reduction modes the data is read and scanned only.

During the move there is no data displayed on the CRT display.

The move function will terminate when it encounters a time equal to, or greater than, the time specified by the user. When the move is terminated, the display is re-established with the left end of the time (X) axis representing the time which terminated the move. If the end-of-file mark on the input file is encountered before a time which would terminate the move, no more data for that input file will be displayed and end-of-file processing will take place.

The MOVE Command is:

* M DAY HOUR MIN SEC MT

where

M	is the command indicating a move
DAY	is a three-digit day of year (0-365)
HOUR	is a two digit hour of day (0-23)
MIN	is a two digit minute (0-59)
SEC	is a two digit second (0-59)
MT	is the minor time

Example:

* M 273 14 51 15 763

will bring the user to the data at or beyond the 763rd minor time cycle of the 273rd day, 14th hour, 51st minute, 15th second. It is possible that improper time input from a noisy time channel may prematurely end the move. Also, if only part of the time is specified (e.g., only day and hour) the remaining units are automatically set at zero.

After receiving the move command, in the Edit mode, the system will inquire what is to happen to the data bypassed. In the Calibrate or Reduction modes, the following is bypassed.

TYPE CHANNELS TO BE CANCELLED

* REPLY

where REPLY may be

- i) A Cancel-delete all channels.
- ii) I Cancel-ignore all channels.
- iii) N Do not cancel any channels.
- iv) D ab, ... Cancel-ignore displayed channels and channels a,b,....
- v) a,b,... Cancel-ignore channels a,b,....

The cancel function is available in the Edit mode only. It allows the user to selectively delete data from all channels on the output tape (cancel-delete) or to flag data in selected channels on the output tape (cancel-ignore). Canceling takes place on the data appearing between the verniers on the display or, when moving, on the data between the beginning vernier on the page on which the move was started and the time which terminated the move.

In the case of the cancel command, the effect is immediately evident on the display by means of gaps in the displayed data. When the data has been deleted, the gap will be 100_g display units wide. When it has been ignored, the gap will be as wide as the distance between the verniers. The difference is a result of the way in which the display routines display the data. When the data has been deleted it has been eliminated from the data base. Thus, when the display routines encounter this gap, the time difference between the time at the beginning and end of the gap would result in a gap in the display that could be quite wide. The display routines were written so that should they encounter a gap in time, they would limit the gap to 100_g display units. These time differences may not be the result of canceling alone but can also be caused by a noisy time channel on the analog tape.

When the data has been cancel-ignored the time values are not affected. The display routines just don't display the flagged data point.

The CANCEL Command is typed as follows:

* C ARG

where ARG is the same as REPLY in the MOVF Command except that if ARG is N, there will be no tangible results.

EDSYS provides the user with the ability to print the time associated with selected data points on the display. These points are selected by use of the verniers.

The user may determine the times at the vernier by the following teletype commands:

- i) * Type out both times
- ii) * TB Type beginning time (left vernier)
- iii) * TE Type end time (right vernier)

EDSYS also provides the user with the ability to print the value of selected data points. As before, the data points are selected by the verniers but with the addition of channel selectivity. The VALUES command is typed as follows: (Portions of the command in parentheses are optional)

* (B or E)(C) a,b,... or A

B or E indicates that the values at only one or the other of the verniers are to be printed - B for the beginning (left) vernier or E for the ending (right) vernier. If neither B nor E is typed the values at both verniers will be printed.

C, if present, indicates that the actual (calibrated) values and associated unit of measures are to be printed along with the digital values. If the input file is not calibrated and EDSYS is not in the Calibration mode, the C option will be ignored. If the input file has been calibrated or EDSYS

is in the Calibration mode and the C option has been entered but no calibration sets exist for a channel to be printed, then EDSYS will print a zero value and no unit of measure. The digital value is always typed and ranges between 0 and 510. If the digital value is odd it indicates that the data point has been flagged (cancel-ignored).

The a,b,... portion of the command is the list of channels whose values are to be printed. If all channels are desired, the user may type 'A'. If neither the channel numbers nor A is typed, no values are printed.

By means of the CAL command the user may create calibration sets. This command is valid in the Calibration mode only. It works in conjunction with the vernier on the display. The user must first position the calibration curves of his data on the display. This is accomplished by use of the various facilities of EDSYS; notably, the MOVE command and/or the Pacing Dot. Once the data is in position, the user may select the channel to be calibrated. To select the channel the user may use the light pen just as he would if he were expanding or contracting the data along the Y axis, or he may type the channel number with the CAL command. If both methods are used at the same time, the number typed with the CAL command will over-ride the light pen selection.

The CAL command is typed as follows:

* CAL (cccc or END) (channel number)

The first option (cccc or END) is the four character unit of measurement abbreviation. Once entered for a channel it will be duplicated in each calibration set for that channel without the necessity of typing it each time. It can be changed by typing a different unit of measure in a subsequent CAL command for that channel. If END is typed, EDSYS will terminate processing the file just as though an end-of-file mark had been read on the input tape. In this case,

EDSYS asks the user if he desires to edit the file now or just copy it onto the output tape behind the calibration block just created.

The channel number need not be typed if the channel has been selected via the light pen. If it is typed, it can be typed either before or after the unit of measure.

EDSYS will respond to the CAL command by printing:

SET BAR THEN TYPE VALUE

>
_

The user should respond by using the vernier to select the point on the selected channel's calibration curve which he wishes to pair with an actual value. Once the vernier is positioned he may type in the actual value. The format for the type-in is free form. It may be a decimal fraction or an integer and may be signed or unsigned. Several examples follow:

≥ -3

≥ 3

≥ 1.5

≥ -1.5

If the user types a character other than a plus or minus sign, a decimal point, a number, an X or an E, EDSYS will respond by printing a question mark and sounding the bell. This means that as long as there is a > in the left margin of the current line on the teletype that none of the normal EDSYS commands will be recognized. When the error indication is typed the user may retype the value.

After EDSYS has accepted the entry it will respond by printing a >. The user may then position the vernier for the next value. If he fails to move the vernier to a new point, the next value entry will cause EDSYS to print an error message. This will not disturb any preceding entries. The user may still position the vernier and type the value to continue building the calibration set.

EDSYS will accept up to four values after which it will calculate the coefficients to a 3rd order polynomial and store them in the calibration set. If there are fewer than 4 values to be entered the user may type E to indicate no more values are to be entered. If less than two values have been entered, EDSYS will respond with an error message, erase the calibration set it was building and return to normal processing.

If the user finds he has made an error and wishes to start the CAL command over again, he may type X. Entering X will cause EDSYS to erase the calibrating set being built and to print * to indicate normal processing has resumed.

The Command command-COM- is a part of the Reduction mode and is invalid in any other mode. It permits the user to record any text he desires, in a reduced tape comment block.

The Comment command is entered as follows:

* COM

EDSYS will respond by printing a > . The user can then type in any text he wishes. The normal typing conventions apply to each individual line of text. When typing a comment under control of the COM command, the carriage return indicates the end of the current line of comment, not the end of message. EDSYS will respond by printing > after which the user may proceed with his next line of comment. The > at the left of the page indicates in this instance that any typing by the user will be considered part of the comment. The last line of comment is terminated by the ALT MODE key not the carriage return key, to indicate the end of the comment. This action causes EDSYS to terminate the input of the comment from the teletype and write the assembled comment block onto the output tape. It also causes an * to be printed at the left of the page to indicate all normal EDSYS commands are effective again.

The display of data on the CRT is not lost during the COM command.

The Set command is also part of the Reduction mode and is invalid in any other mode. It permits the user to create and to record reduced data sets on

the reduced output tape.

To use the Set command the user first selects, via the light pen, the channel containing the data he wishes to reduce. He then must position the left (or B for beginning) vernier to select the data point of interest. If he desires to reduce a block of data from the selected channel, he must also position the right (or E for ending) vernier to select the last data point of interest.

He then enters the Set command as follows:

* S (cccc) or

* SA (cccc)

(The parentheses are never to be typed; they just indicate an optional entry.)

The S command will reduce the one data point indicated by the left vernier for the selected channel. The SA Command will reduce all the data points between the verniers for the selected channel.

The optional 5 characters entry (comment) will be inserted into the comment value portion of the reduced data set or sets created by this command. It may be less than 5 characters in length. If the comment value is not typed in, that portion of the reduced data set may be filled with zeros or the unit of measure abbreviation. If the input file is not calibrated or there are no calibration sets in the calibration block for the selected channel, and no comment value was entered, then the comment and calibrated values will be zero. If there is a calibration set for the selected channel and no comment value has been typed in, the comment value of the reduced data set will contain the unit of measure abbreviation from the calibration set used to calculate the calibrated value. That calibration set is the set for the selected channel which contains the time nearest to, but less than or equal to, the data point time. If no set exists with those time limitations, the set for the selected channel with a time nearest to, but greater than, the data point time will be used.

As reduced data sets are created they are accumulated in a 256 word block of core memory until there is no room for any more sets, at which time the block is written onto the reduced output tape, the core memory block is cleared to zero and the process is repeated.

Processing of an input file normally terminates in two ways. In the Calibrate mode it may terminate by the user typing a CAL END command. In any mode it terminates when an end-of-file mark is read from the input tape. The latter can result only under the influence of a MOVE Command or paging, since these are the only times the input tape is read.

When the processing of an input file is completed, the user may, under certain conditions, append another output file to the one just created. In the Calibrate mode no appending can ever take place. In the Reduction mode appending can always take place. In the Edit mode appending can take place only if both the file being appended to and the file being appended are not calibrated. EDSYS will print the end-of-file indication on the teletype and if not in the Calibrate mode and if the input file was not a calibrated file, EDSYS will ask the user, "SAME OUTPUT FILE?" to which he may respond by typing, "Y(ES)" or "N(O)". If his answer was "Y(ES)", EDSYS will cause the output from processing the next accepted input to be appended to the current output file, if it meets the criteria for appending. That criteria are, EDSYS must not go into the Calibrate mode for processing the new file and the new file must not be calibrated. Also, the new file must be capable of being restructured and/or having the same sample rate as the original file.

If the answer to the question "SAME OUTPUT FILE?" was "N(O)", appending will not take place. When appending is not going to take place, an end-of-file mark will be written on the output tape.

Whenever EDSYS writes an end-of-file mark on the output tape it asks the user, "END OF OUTPUT TAPE?". Again, he can respond with Y or N. If he responds with a Y, another end-of-file mark is written on the output tape to indicate the logical end-of-tape and the output tape is rewound to load point. If he responds with an N, the extra end-of-file mark is not written nor is the tape rewound. In either event, EDSYS will start processing a new input file.

There is one other way in which processing of an input file can be terminated. If the user, for any reason, decides he does not want to continue processing the current file nor does he want to save the output from that processing, he may type the command, "ABORT". This command is effective in all modes as long as EDSYS has printed an * on the left of the current line. ABORT will cause both the input and output tapes to space backwards to the last end-of-file mark or load point, whichever is encountered first. The ultimate position of the tapes will be at load point or just after (in a forward direction) the end-of-file marks. This position is sometimes called "beginning-of-file".

If appending is or has taken place in the output file, it should be remembered that the output tape position will be at the beginning of the total file - not at the beginning of the output of the last input file. Therefore, if appending is taking place, the ABORT command should be used with care.

When the ABORT command has finished positioning the tapes, EDSYS will ask the user if it is the "END OF OUTPUT TAPE?". His response and the response of EDSYS may be ^{as} explained before.

.3 System Configuration

The Sagamore Hill Edit System (EDSYS) configuration can be considered in two parts; the hardware configuration and the software configuration.

3.1 Hardware Configuration

The minimum hardware necessary for EDSYS to operate is:

- 1 - Digital Equipment Corp.(DEC) PDF-9 Data Processor with 16K core memory and the Extended Arithmetic Element (EAE).

- 2 - DEC Type TU20 magnetic tape units
- 1 - DEC Type TU55 "Dectape" units
- 1 - DEC Type 30D Precision CRT Display with a
Type 370 Photomultiplier Light Pen.

There is other hardware at the Sagamore Hill installation but it is not directly required for EDSYS Hardware Configuration to operate.

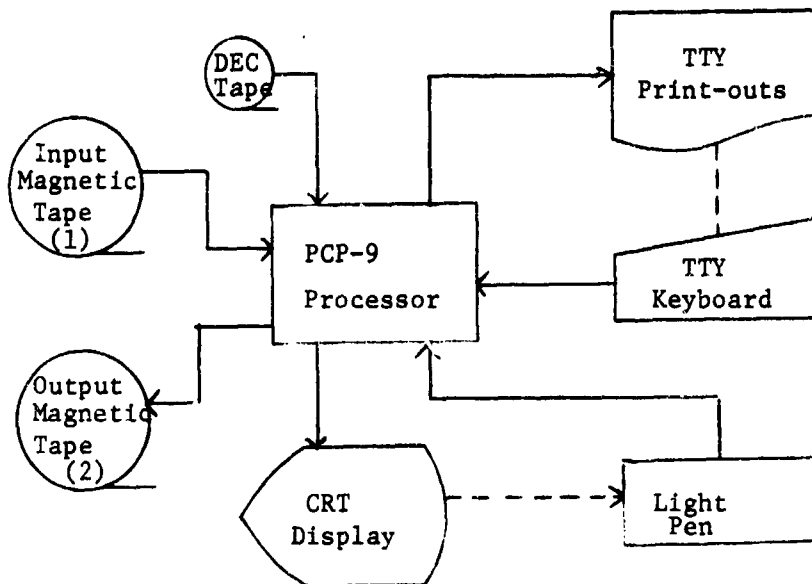

Figure 11

3.2 Software Configuration

Figure 12 is a flowchart which describes the relationship of one program to another. All programs in EDSYS are not included in the flowchart. Those that are left out are subroutines used by many of the programs. A list of all of the programs in EDSYS and a brief description of each follow:

- ABORT - Positions both magnetic tapes to the beginning of their current files.
- ASTRIK - A closed subroutine which prints an asterisk (*) on the Teletype (Part of INTYPE).
- BKSP - A closed subroutine which backspaces specified magnetic tape a

specified number of records or to end-of-file mark or to load point, whichever occurs first. (Part of ABORT)

- CALCOE - Sets up entry and arrays IKNT, COM and COEF for FORTRAN IV subroutine COEFCA.
- CALSET - Accepts analog counts (digitized values) and true values, calculates the coefficients for a third order polynomial and stores them along with the time and unit of measure into a block of calibration sets.
- CALVAL - A closed subroutine which searches the calibration block for the most recent calibration set and uses it to calculate the actual values of the selected data point.
- CANCEL - Flags data to be cancelled.
- CLEAR - A closed subroutine which clears specified areas of core memory. (Part of INTYPE)
- COEFCA - A Fortran IV subroutine which calculates the four coefficients of a third order polynomial.
- COMMA - A closed subroutine which packs the 8 bit ASCII code for a comma (,) into the teletype output buffer (Part of INTYPE)
- COMENT - Accepts comments entered via the Teletype under the COM command and writes them on a reduced tape.
- CRLF - A closed subroutine which prints a carriage return and line feed on the Teletype (Part of INTYPE)
- DAYHR - A closed subroutine which unpacks the first major time word (TCT format) which contains days and hours.

DCYCLE - Processes input/output on the Teletype while data is being displayed on the display CRT.

DECRDA - Decrements the Y axis display area for light pen selected channels.

DISDAT - Displays data from the desired channels. Also sets up data pointers according to the settings of the verniers.

DNUMBR - Display the channel number of the channels being displayed. Also displays the X-Axis Select Dot and the dot beside a light pen selected channel number (if any) to indicate which channel (if any) has been light pen selected.

DOUNPK - A closed subroutine to convert decimal numbers which have been entered thru the Teletype, to binary, and return to the calling program with the first non-numeric character code stored in the location following the calling UMS instruction and the binary number in the AC. (Part of INTYPE)

ENDFIL - Performs end-of-file processing and initiates appending. (Part of FILHED)

FILHED - Interprets the header record, prints its contents on the Teletype and does a variety of other processing to setup for processing a file.

FWDSP - A closed subroutine for spacing in a forward direction the selected magnetic tape a specified number of records or to an end-of-file mark or to physical end-of-tape whichever occurs first. (Part of ABORT)

GTCHNO - A closed subroutine which retrieves a channel number from an argument list and compares it with a list of channel numbers to determine its position within a data set.

INCRDA - Increments the Y axis display area for light pen selected channels.

INTYPE - The name of a collection of closed subroutines which handle Teletype input/output functions and clears core. The subroutines contained in INTYPE are: ASTRIK, CLEAR, COMMA, CRLF, DOUNPK, LISTEN, ODPACK, PACK, SPACE, TTREAD, TTWRIT and UNPACK.

LISTEN - A closed subroutine which prints an asterisk (*) and initializes a Teletype read. (Part of INTYPE)

LITPEN - Light pen interrupt service routine (Part of PEN.)

MNSC - A closed subroutine which unpacks the second major time word (TCT format) which contains minutes and seconds. (Part of DAYHR)

MOVE - Initiates a move under the MOVE command.

NIT1 - Sets the beginning address of TEMPRF, the display buffers, CALBLK and REDUBF. It initializes all I/O handlers and rewinds the input tape to load point. The rest of NIT1 is used as common storage.

ODPACK - A close subroutine to convert a binary number to decimal characters and pack them in the Teletype output buffer for subsequent printing. (Part of INTYPE)

PACK - A closed subroutine which will pack one character code per call into the Teletype output buffer for subsequent printing.

PEN. - Light pen interrupt handler which interprets a light pen interrupt and the appropriate action indicated by the contents of BOTFLG.

POLY - A closed subroutine which calculates, via a third order polynomial, the real value of a digitized data point.

PRFCAN - Decodes the argument list for the CANCEL command and sets up parameters for CANCEL.

READBF - Reads the input tape, restructures the data when called for and moves the data into the display buffers.

SFTDIS - Determines which channels are to be displayed and the Y axis display area for each of these channels.

SPACE - A closed subroutine which packs a space character code into the Teletype output buffer. (Part of INTYPE)

TIMES - Prints the day, hour, minute and second and the minor time value represented by either one or both verniers.

TTREAD - A closed subroutine which reads a message from the Teletype into the Teletype input buffer until a carriage return is typed. (Part of INTYPE)

TTWRIT - A closed subroutine which writes a message onto the Teletype from the Teletype output buffer until a carriage return is encountered. (Part of INTYPE)

UNPACK - A closed subroutine which unpacks one character code per call from the Teletype input buffer. (Part of INTYPE)

UPDOWN - A closed subroutine which displays 10 dots on the display CRT according to the bit pattern of an input word.
Primarily used by DNUMBR to display channel numbers.

VALUES - Prints the digital count at one or both of the vernier positions for one or more channels. Calibrated (real) values of the data points may also be printed if the channel(s) has been calibrated.

- VERTAL - Displays and moves the verniers; displays the Expansion and Contraction Dots; displays the Paging Dot.
- WRITBF - Deletes cancelled data, writes the 1st display/output buffer onto the output tape and condenses the data after writing.
- YORN - A closed subroutine which will determine whether a "Y" or "N" was typed in response to a query. (Part of INTYPE)

In the accompanying System Flowchart the connector symbols (circles) have a certain convention. Those connectors containing a single number without a decimal point are on-page connectors. That is, they refer to a connector on the same page or are a destination from the same or another page. Those connectors containing a number with a decimal point are an off-page connector. The number before the decimal point refers to the page of the flowchart and the number after the decimal point refers to the connector on that page.

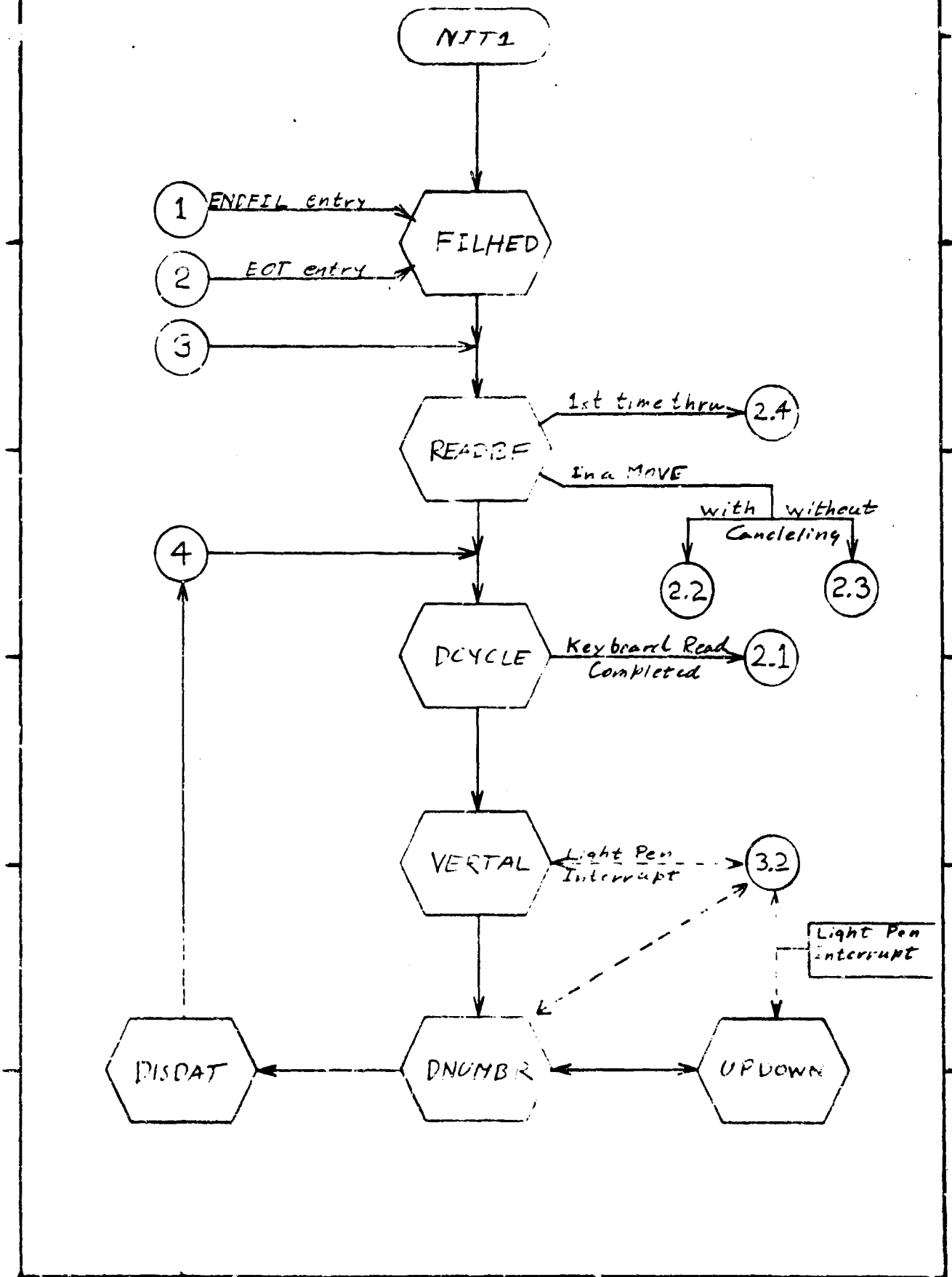

Figure 12.1

System Flowchart Page 2.

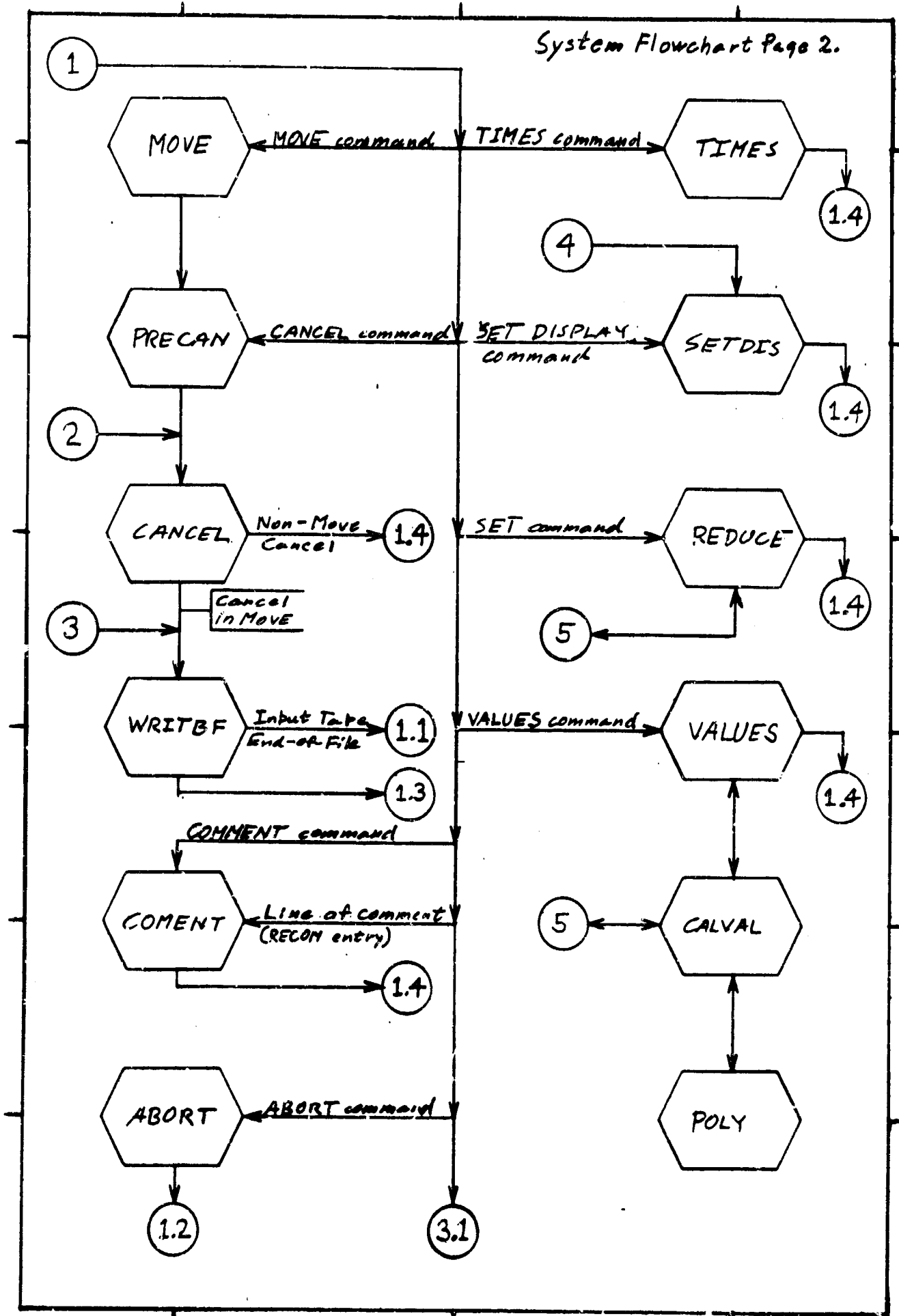
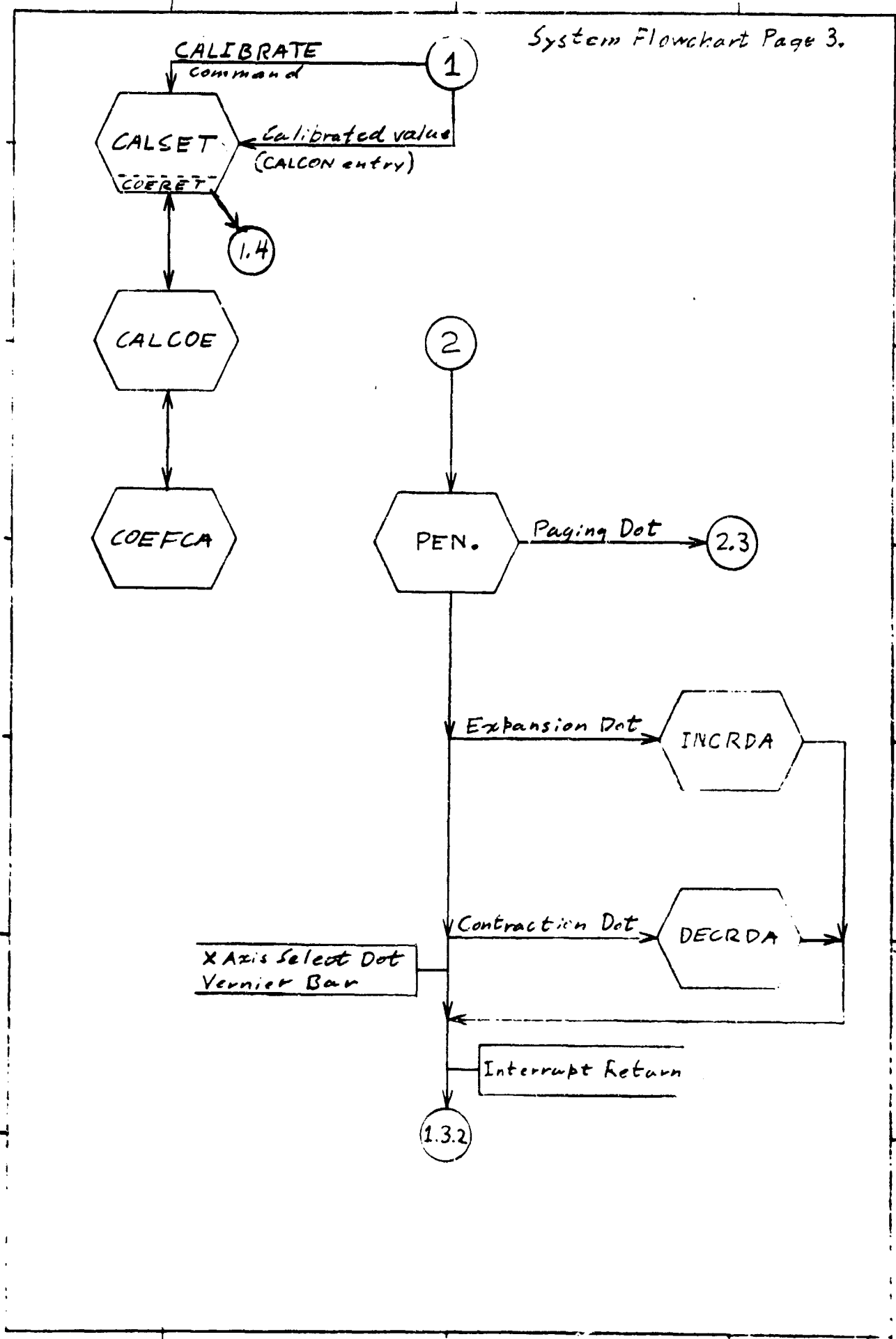

Figure 12.2



2-43 Figure 12.3

SECTION 3

Surface Wave Propagation

The field of microwave acoustics has, in the past few years, experienced a resurgence with the shift in emphasis from bulk to surface waves. The potential is present to develop miniature microwave components for high-speed signal processing and avionics systems, among others, although there still remain many technical problems. Microwave acoustics involve the generation, propagation, and signal-processing of acoustic waves in and along the surface of solid materials. This project is involved with the propagation characteristics of surface wave on general piezoelectric crystal surfaces in the presence of perfect electric and magnetic conductors.

A rectangular co-ordinate system with the X_3 axis perpendicular to the crystal surface and the X_2 axis in the direction of propagation is selected. Various orientations of the crystal surface with respect to the crystal axes are to be considered. In order to accomplish this, the crystal axes must undergo a rotation through the Euler Angles. The matrix defining this rotation is

$$V = \begin{pmatrix} \cos \alpha \cos \gamma - \sin \alpha \cos \beta \sin \gamma & \sin \alpha \cos \gamma + \cos \alpha \cos \beta \sin \gamma \sin \beta \sin \gamma & \\ -\cos \alpha \sin \gamma - \sin \alpha \cos \beta \cos \gamma & -\sin \alpha \sin \gamma + \cos \alpha \cos \beta \cos \gamma \sin \beta \cos \gamma & \\ \sin \alpha \sin \beta & -\cos \alpha \sin \beta & \cos \beta \end{pmatrix}$$

where α, β, γ , are the Euler Angles. The differential equations for mechanical displacements and electric potential are independent of the surface under consideration, only the values of the coefficients change with the surface orientation, relative to the crystal axes. The tensor quantities of interest, i.e. the elastic constants (c_{ijkl}) , piezoelectric constants (e_{ijk}) and the dielectric constants (ϵ_{xj}) are transformed by:

$$C^1_{ijkl} = \sum_{r,s,t,u=1}^3 V_{1r} V_{Js} V_{CT} V_{LU} C_{rstu}$$

$$e^1_{ijk} = \sum_{r,s,t=1}^3 V_{1r} V_{Js} V_{kT} e_{rst}$$

$$\epsilon^1_{ij} = \sum_{r,s=1}^3 V_{1r} V_{Js} \epsilon_{rs}$$

where the primed quantities refer to a rotated co-ordinate system and the unprimed to when the crystal surface and crystal axes systems coincide.

The equations for the components $\bar{U}_1, \bar{U}_2, \bar{U}_3$ of mechanical displacement and electric potential, ϕ , are

$$1 \left\{ \begin{array}{l} C^1_{ijkl} U_{k)Li} + e_{kij} \phi_{ki} = \rho \frac{\partial^2 U_1}{\partial t^2} \\ e^1_{ikL} U_{k)Li} - \epsilon^1_{ik} \phi_{ki} = 0 \end{array} \right\} X_3 > 0$$

$$2 \quad \nabla^2 \phi = 0 \quad - h \leq Z \leq 0$$

Considering displacement and potential independent of the X2 co-ordinate, we are seeking solutions of the form:

$$U_i = \beta_i e^{-\alpha \omega X_3 / V_s} e^{i\omega(t - X_1 / V_s)} \quad i = 1, 2, 3$$

$$\phi = \beta_4 e^{-\alpha \omega X_3 / V_s} e^{i\omega(t - X_1 / V_s)}$$

Substituting these solutions into the above differential equations yields a system of four equations in the unknowns $\beta_1, \beta_2, \beta_3, \beta_4$. In order for a non-trivial

solution to exist the determinant of the coefficients must equal zero, i.e. given a V_s our problem is to find an α such that the determinant of the following matrix equals zero.

$$\begin{array}{cccc}
 C_{55}\alpha^2 + 2C_{15}i\alpha - C_{11} + \rho V_s^2 & C_{45}\alpha^2 + [C_{14} + C_{56}]i\alpha - C_{16} & C_{35}\alpha^2 + [C_{13} + C_{55}]i\alpha - C_{15} & e_{35}\alpha^2 + [e_{15} + e_{31}]i\alpha \\
 & & & -e_{11} \\
 C_{45}\alpha^2 + [C_{14} + C_{56}]i\alpha - C_{16} & C_{44}\alpha^2 + 2C_{46}i\alpha - C_{66} + \rho V_s^2 & C_{34}\alpha^2 + [C_{36} + C_{45}]i\alpha - C_{56} & e_{34}\alpha^2 + [e_{14} + e_{36}]i\alpha \\
 & & & -e_{16} \\
 C_{35}\alpha^2 + [C_{13} + C_{55}]i\alpha - C_{15} & C_{34}\alpha^2 + [C_{36} + C_{45}]i\alpha - C_{56} & C_{33}\alpha^2 + 2C_{35}i\alpha - C_{55} + \rho V_s^2 & e_{33}\alpha^2 + [e_{13} + e_{35}]i\alpha \\
 & & & -e_{15} \\
 e_{35}\alpha^2 + [e_{15} + e_{31}]i\alpha - e_{11} & e_{34}\alpha^2 + [e_{14} + e_{36}]i\alpha - e_{16} & e_{33}\alpha^2 + [e_{13} + e_{35}]i\alpha - e_{15} & -e_{33}\alpha^2 - 2e_{13}i\alpha \\
 & & & +e_{11}
 \end{array}$$

where the C 's are the elastic constants, the e 's the piezoelectric constants, and the ϵ 's the dielectric constants. This involves solving an eighth order equation in α . For each α value which has a positive real part we obtain

values of $\beta_1, \beta_2, \beta_3, \beta_4$. Since field amplitudes are arbitrary we take $\beta_4 = 1$ and find $\beta_1, \beta_2, \beta_3$, from three of the remaining four homogeneous equations.

Assuming the surface of the crystal is free of stress the mechanical boundary conditions are

$$T_{3j} /_{x_3=0} = C^l_{3jkl} U_{k,L} + e^l_{K3J} \phi_{,K} /_{x_3=0} = 0$$

$$\phi = 1, 2, 3.$$

Now the mechanical displacement and potential may be experienced as a linear combination of fields associated with allowable values of 2 ; thus for $X_3 \geq 0$

$$4 \quad U_1 = \sum_{j=1}^4 A(j) \beta_1(j) e^{-\alpha(j)\omega X_3/V_S} e^{i\omega(t-X_1/V_S)} \quad i = 1, 2, 3$$

$$5 \quad \phi = \sum_{j=1}^4 A(j) \beta_4(j) e^{-\alpha(j)\omega X_3/V_S} e^{i\omega(t-X_1/V_S)}$$

while in the interval $-h \leq X_3 \leq 0$ (using equation 1 and the above derived boundary conditions) we get

$$6 \quad \phi = \sum_{j=1}^4 A(j) \beta_4(j) \operatorname{csch} \left(\frac{wh}{\sqrt{S}} \right) \sinh \left(\frac{w}{\sqrt{S}} (X_3+h) \right) e^{i\omega(t-X_1/V_S)}$$

Lastly since the component of the normal must be continuous across $X_3 = 0$ the electric displacement is given by

$$D_i = e_{iKL} U_{K,L} - \epsilon_{iK} \phi_{,K} \quad \text{in } X_3 = 0 \quad i = 1, 2, 3$$

$$\vec{D} = -\epsilon \nabla \phi \quad \text{in } -h \leq X_3 \leq 0$$

Using equations 4, 5, and 6 we get the following set of homogeneous equations for the amplitudes $A^{(j)}$:

$$7 \quad \sum_{j=1}^4 [\beta_1^{(j)} [iC_{15+\alpha}^{(j)} C_{55}] + \beta_2^{(j)} [iC_{56+\alpha}^{(j)} C_{45}] + \beta_3^{(j)} [iC_{55+\alpha}^{(j)} C_{35}] + \beta_4^{(j)} [ie_{15+\alpha}^{(j)} e_{35}]] A^{(j)} = 0$$

$$8 \quad \sum_{j=1}^4 [\beta_1^{(j)} [iC_{14+\alpha}^{(j)} C_{45}] + \beta_2^{(j)} [iC_{46+\alpha}^{(j)} C_{44}] + \beta_3^{(j)} [iC_{45+\alpha}^{(j)} C_{34}] + \beta_4^{(j)} [ie_{14+\alpha}^{(j)} e_{34}]] A^{(j)} = 0$$

$$9 \quad \sum_{j=1}^4 [\beta_1^{(j)} [iC_{13+\alpha}^{(j)} C_{35}] + \beta_2^{(j)} [iC_{36+\alpha}^{(j)} C_{34}] + \beta_3^{(j)} [iC_{35+\alpha}^{(j)} C_{33}] + \beta_4^{(j)} [ie_{13+\alpha}^{(j)} e_{33}]] A^{(j)} = 0$$

$$10 \quad \sum_{j=1}^4 [\beta_1^{(j)} [ie_{31+\alpha}^{(j)} e_{35}] + \beta_2^{(j)} [ie_{36+\alpha}^{(j)} e_{34}] + \beta_3^{(j)} [ie_{35+\alpha}^{(j)} e_{33}] - \beta_4^{(j)} [ie_{13+\alpha}^{(j)} e_{33}] + \epsilon_0 \coth \left(\frac{wh}{\sqrt{\epsilon}} \right)] A^{(j)} = 0$$

By solving the equation obtained by setting the determinant of the above system equal to zero we obtain the allowable surface wave velocities.

As a by-product of this problem the components of stress, strain, electric displacement, electric potential, electric field, and average power flow are calculated as functions of WX_3 . The computer program has the option to print out any or all of these quantities.

Project Number: 5635

Problem Number: 1614

Researcher: Lt. A. Slobodnik Jr., U. S. A. F.

SECTION 4

ATMOSPHERIC TRANSMITTANCE

The ability to compute atmospheric transmittance by a straight forward monochromatic technique was first attempted by Gates et al¹ in the region of the 2.7 micron water vapor bands. They published a detailed listing of water vapor lines in that spectral region which included calculations of atmospheric transmittance at infinite resolution and at a somewhat more realistic resolution degraded by an appropriate triangular slit function. Research was continued and resulted in a second publication by Benedict and Calfee² in which a similar set of spectroscopic parameters and calculations were published for the 1.9 and 6.3 micron bands of water vapor.

Since this work was first started, the need for a similar calculation capability in other spectral regions in which other atmospheric gases are the primary absorbers has developed among those in the scientific community. A number of individual researchers have set about to determine the fundamental spectroscopic data required for their specific needs.^{3,4} However, until the conception of this program there had been no continued effort made to provide the complete set of data and calculation techniques for all neutral atmospheric gases in the entire infrared region.

It has been necessary to compile the fundamental spectroscopic data (including line intensities, frequencies, half-widths and energies of the lower state) of all spectral lines of all molecules responsible for atmospheric absorption in the region of interest. The program combines laboratory and theoretical efforts in attaining the best set of band constants for the atmospheric absorbing molecules involved and then from these are calculated the required spectroscopic data. The final determination of spectroscopic constants is actually an iterative procedure in which a set of spectroscopic data for a particular molecule is established and used in the calculation of transmittance

over a homogenous laboratory-type path. If the calculated spectra do not compare favorably with the laboratory spectra for a range of laboratory conditions, adjustments in the spectroscopic data have to be made. Thus, the final set of data for any particular molecule is made to agree with laboratory data and it is self-consistent with spectra at various frequencies due to absorption by the same molecule.

The atmospheric gases included in this work are: CO_2 , H_2O , O_3 , N_2O , CO , CH_4 , O_2 , N_2 , and HNO_3 . All these molecules exist in the portion of the atmosphere where the assumption of local thermodynamic equilibrium is valid. Consequently, the ability to calculate the transmittance together with the standard integral formulation of the equation of radioactive transfer and a knowledge of the atmospheric temperature distribution allows the calculation of atmospheric emission. The remaining difficulty in the application of the fundamental spectroscopic data to the calculation of transmittance over non-homogenous paths such as those traversed by radiation in the real atmosphere is a knowledge of molecular abundances and the distribution of abundance with height. The calculation procedures are applicable to any molecule for which the spectroscopic parameters and abundance distributions are available.

A significant source of uncertainty in these transmittance calculations results from uncertainties in transmittance line shape. To avoid this, Doppler shapes are assumed at low pressures; the Voigt profile is assumed at intermediate pressures; and, the Lorentz shape assumed at high pressures. Any departures from these will be solved by direct use of experimentally determined continuum absorption coefficients.

Since large amounts of computer time are required to make calculations in a detailed manner for low resolution requirements, it is parsimonious to use the available spectroscopic data with an appropriate band model and perform a series of tests, checking this band model against the detailed point-by-point calculations. Ideally, a single band model when used with the detailed spectroscopic

data might be applied anywhere in the spectrum. Initial investigations of this possibility look promising, but additional testing is still required.

The acquired spectroscopic data can be computed through examination of solar and laboratory spectra and through theoretical understanding and calculations to determine molecular energy levels and other fundamental parameters. These are then translated into line intensities, frequencies, half-widths, and energies of the lower state of each transition involving the formation of a spectral line. The next phase of the research makes laboratory absorption measurements with which theoretical calculations are to be compared in order to arrive at the best set of spectroscopic parameters; measurements are also made of continuum absorption coefficients for direct input to the calculation scheme. Another phase of the research measures atmospheric transmittance and emission from balloon-borne radiometers and spectrometers under a variety of atmospheric conditions. The calculated results are then compared with these measurements in order to establish both the accuracy of the measurements and the validity of the calculations.

All the preceding activities are coordinated to develop and maintain the capability of making both point-by-point (monochromatic) and band model calculations of atmospheric transmittance and emission between 0.3 microns and the far infrared using the detailed spectroscopic data as basic input data. The widespread application and interest aroused by an overall computer program has, thus, brought many scientists to contribute their time and effort. Presently, spectroscopic data has been compiled in its interim form, i.e. data consistent with current theory and experiments. It is, however, subject to revision as new experimental and theoretical results are obtained. An effort is being made to frequency order all of this available spectroscopic data and put it on one magnetic tape so that a calculation procedure can be systematized and absorptions due to all molecules occurring in the atmosphere can be accounted for in a given spectral interval. Currently, calculations of atmospheric transmittance

when a single molecule absorbs in a given spectral region can be made. However, a program is being developed to read the magnetic tape and concurrently compute the atmospheric transmittance between any two points due to absorption by any or all atmospheric constituents.

Despite the difficulty in defining an atmospheric model, a limited number of models will be outlined and calculations of transmittance and emission will be made when the data and computer programs become available. These calculations will be made with the intent of providing a range of results sufficient for a wide variety of potential user problems especially concerned with the transfer of radiation through an atmosphere containing aerosols and molecular scatterers and also applicable to the problem of radiation transfer through clouds.

Problem Number: 7670
Project Number: 1567
Researcher: Dr. R. A. McClatchey

SECTION 5

FAIL-SAFE DECODING-EXPERIMENTAL RESULTS

A decoding algorithm for error correcting block codes is the basic theory behind the Hobbs Encoder-Decoder invention. This decoding algorithm gives failsafe decoding with large codes. Binary codes must have at least 50 parity check digits in each word in order to achieve failsafe decoding error probability less than 1×10^{-8} . Thus, in order to achieve more than a coding rate greater than one-half, words of more than 100 bits in length are required. Decoding for such large codes is very difficult to accomplish for correcting more than one or two errors per word with usual decoding algorithms. The decoding algorithm implemented in the decoder can easily be applied to binary codes of several hundreds of digits in length since the size of the decoder grows only linearly with n , the length of a code word.

The decoding algorithm contained in this invention has been implemented in the Frange cyclic code. Previous to construction of this equipment, the decoding algorithm was evaluated using digital computer computation for partial simulation. The experimental results agreed satisfactorily with the results obtained by computer simulation. (see curves in Appendix.) In each Figure, the curve labeled O is the probability of a word being correct and accepted, U is the probability of a word being rejected, P is the probability of a word being accepted in error, and P_0 is the probability (rate) of transmission of errors (per digit) before decoding.

The decoding algorithm falls in the category which has been defined as incomplete in that it does not always give the user an acceptable word as in the case of maximum likelihood decoding. It can be classified as a failsafe decoding method because it only accepts those words which are correct after decoding with a

high degree of certainty. Under normal conditions almost any word which may still have some errors after decoding is labeled as rejected.

The decoding algorithm also differs from other decoding algorithms in that it does not also correct a fixed number of errors. The number of erasures to be made depends on the detector threshold from zero (i.e. error detection) to such a high number that all the words are rejected. An optimum setting of the threshold can be found which minimizes the number of rejections, i.e. the maximum rate of transmission for a nominal signal-to-noise ratio. Also for a particular threshold setting (rather than zero) the decoder corrects a certain number of errors with a particular probability. The experimental decoder set near the optimum threshold corrects words having the number of errors in them with the average percentages being accepted as shown in the table for rather low signal-to-noise signals.

The curves are based on 100,000 word tests and hence not very many samples containing more than just a few errors for evaluating the decoder can be generated unless the S/N is rather low. The failsafe feature is displayed in Table I through the fact that only 42 words were accepted in error out of 5,000,000 words transmitted.

Project Number: 4610
Problem Number: 1660
Researcher: Capt. J. Brazy, U.S.A.F.

SECTION 5

APPENDIX

Notes on Evaluation of Experimental Decoder

By

Charles F. Hobbs

In Figures 1 and 3 we see how the decoding algorithm would work with a Frange Cyclic Code as computed by a digital computer based on certain assumptions and approximations to some of the probabilities occurring in the decoding process where they are almost impossible to compute because of the enormous number of possible situations which may occur. Another way of saying the above is that almost every probability is so interdependent with so many others that they are almost impossible to compute only to a rough approximation.

Figures 2 and 4 are experimental results obtained with the laboratory model of the decoder. Use was made of a channel simulator introducing additive gaussian noise between the encoder and the decoder. The amount of noise could be varied to produce transmission errors over the range of probabilities necessary to evaluate the decoder.

Comparing Figures 1 and 2 it is seen that the performance of the decoder $P_0 = 0.001$ is remarkably similar in all respects with the predictions made by the digital computer. At zero threshold (error detection only) the probability of receiving a decoded word correctly is $Q \approx 0.9$. As the threshold is increased Q increases until it reaches a maximum of 0.99999 and then decreases beyond that point. At no time was any decoding errors made during the 11 series of 100,000 word transmission used to produce the experimental curves. The prediction of the digital computer was that the probability of a word in error would be accepted with a $P < 1 \times 10^{-7}$.

Figure 3 and 4 were plotted to show what happens to the probability of correct decoding and the probability of making decoding errors as the S/N decreases as represented by the probability of transmission errors shown in the graphs. The threshold was held constant near the value which produces the maximum Q for $P_0 \approx 0.001$.

We have called this setting as the "optimum" threshold. It is optimum in the sense of maximizing the Q but a lower threshold would be better in the sense of giving a lesser probability of decoding errors.

Comparing Figures 3 and 4 we see that both the computed values of Q and that of the experimental results start at approximately the same value. However, the experimental results show that Q stays at a value greater than 0.5 until the transmission error rate becomes greater than 0.05 whereas computer results for Q dropped below 0.5 when the transmission error probability becomes greater than approximately 0.015. The experimental word error rate agrees very well with the expected word error probability as computed with simulation.

The curves shown in Figure 5 were computed using equivalent probabilities to these shown on the abscissa when the same energy is used for transmitting a 45 digit uncoded word rather than a 73 digit coded word transferring 45 information digits. Comparing Figure 4 and 5 we see that the experimental results show that the rate of correct decoding, Q , is well above that for the uncoded word. Moreover the rejection rate is less than the probability of error for the uncoded word. Beyond the $P_0 \approx 0.05$ point the probability of error for the uncoded word increases exponentially, whereas for the decoded word only a very small number of words are received in error and the others which would have been received in error without the use of the decoding algorithm are rejected.

From the computer predictions it was anticipated that the optimum threshold for one particular signal level and a particular S/N ratio would not be optimum for other conditions so in an effort to automatically adjust the threshold a mode was built into the decoder-detector which adjusts the threshold as a function of the signal level. Later an Automatic Blank Control (ABC) circuit was added in-house to make the number of erasures per word be as constant as possible for variable S/N ratios.

Figures 6 and 7 give evidence of the successful accomplishment of adjusting the threshold to nearly optimum level for all different levels of signals. This is

because it erases practically the same number of digits regardless of the signal level, whereas with a fixed threshold the number erased would be inversely related to the signal level.

In Figure 6 we see how a fixed threshold (Mode 1) affects the correctness of decoding while holding the rate of transmission error constant and varying the amplitude of the signal level. Figure 7 shows how the automatically controlled threshold holds the correctness of decoding essentially constant.

Table I gives a breakdown of the 5,000,000 words transmitted during a representative run with the threshold adjusted to nearly optimum level on the decoder-detector and in which the S/N is fixed at a value giving the average rate of transmission errors of approximately 0.02. The objective of this table is to display the probabilistic character of the decoding. Note that for the (73,45) code $e = 4$ so that a deterministic decoding technique would always correct 100% of those words having 4 or less transmission errors in them. On the other hand the simplicity of the decoder that we are using converts a few words, which would have been decoded correctly, into rejections. Compensating for this, a high percentage of words having numbers of transmission errors somewhat higher than e are corrected by the decoder. In order to determine the performance of the decoder for large numbers of transmission errors it would be necessary to make runs transmitting a much larger number of words at a fixed S/N.

TABLE I

$a = 1.14v$

$P_0 = 0.01$

No. Errors	No. Words	No. Words Accepted	No. Words Rejected	% Rcd.	No. in Error
0	2,510,620	2,502,650	7,963	99.68	0
1	1,673,880	1,660,480	13,406	99.20	15
2	631,376	623,031	8,345	98.68	14
3	153,045	150,062	2,983	98.05	9
4(e)	27,066	26,378	688	97.46	4
5	3,652	3,495	117	96.76	-
6	356	340	16	95.51	-
7	28	26	2	Sample Too Small	
8	3	3	-	*****	

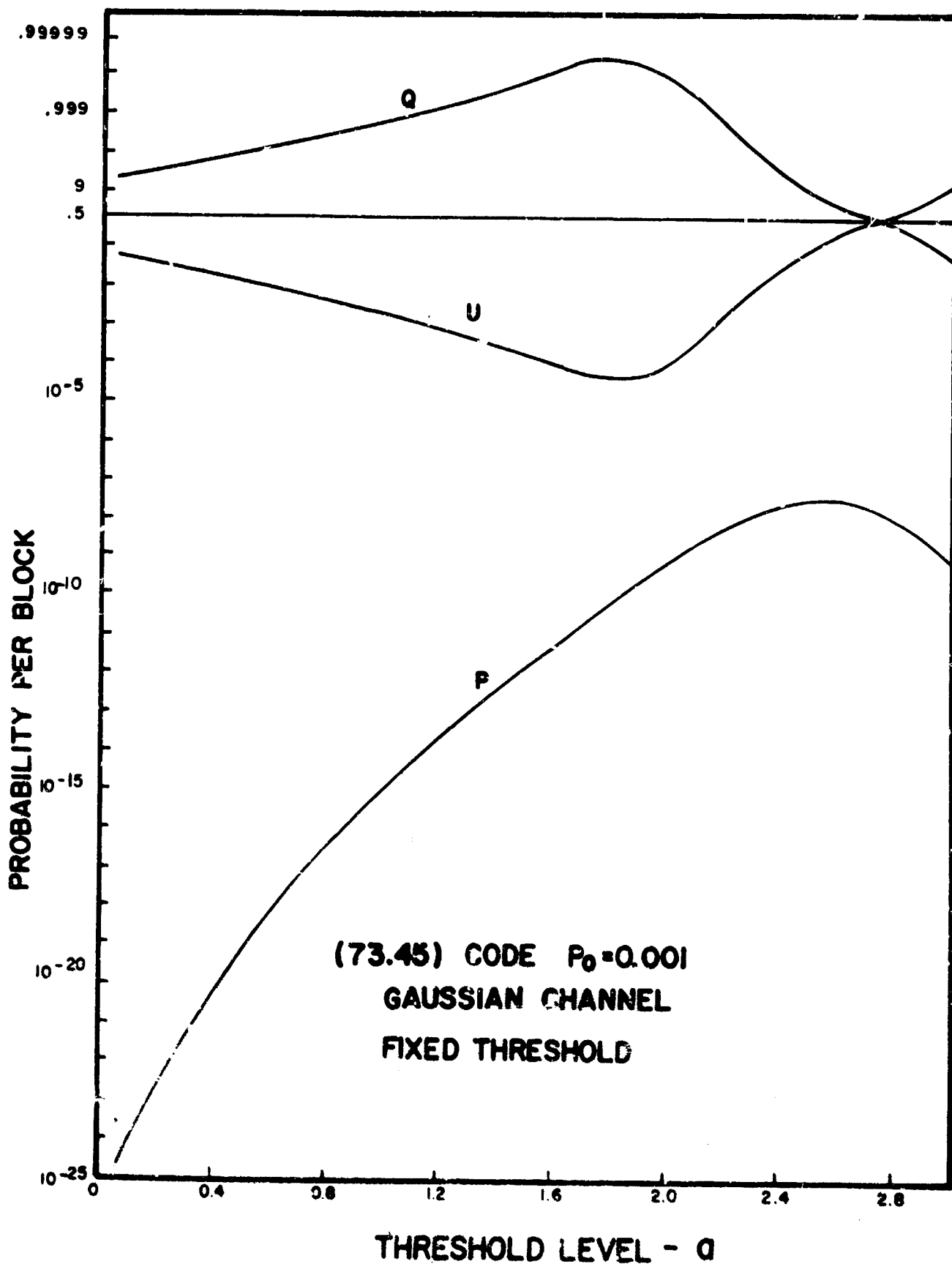

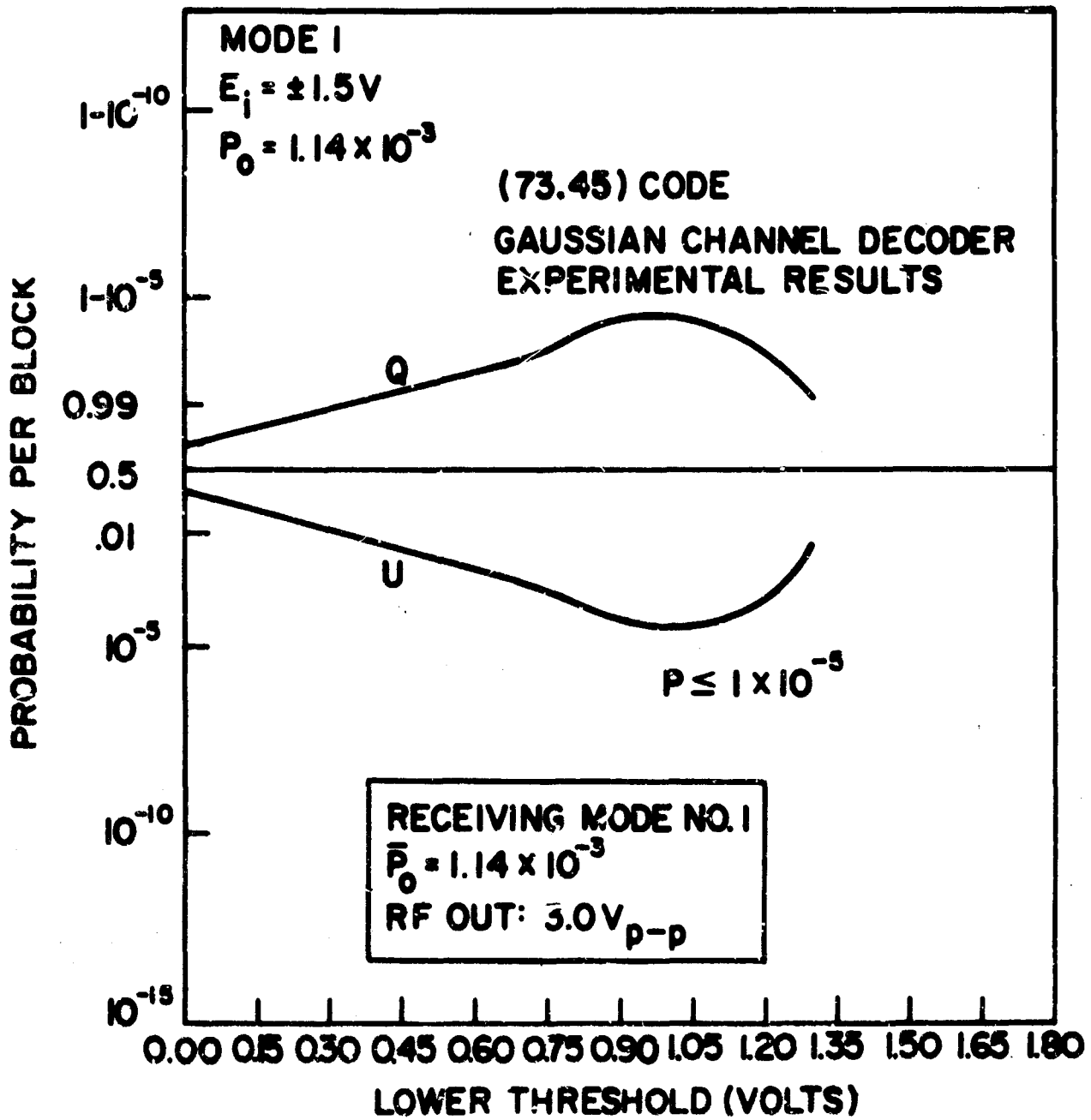

FIGURE 2

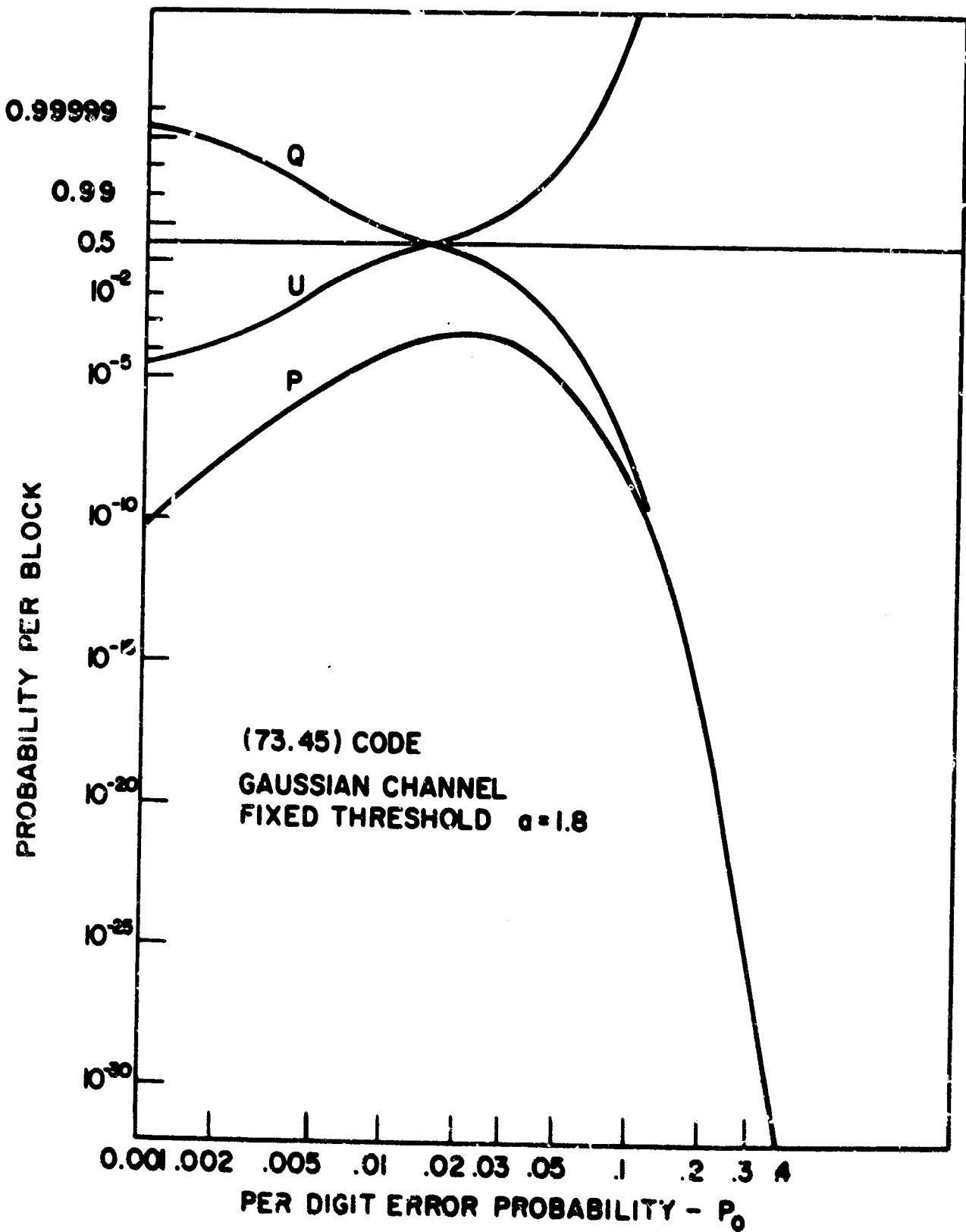

FIGURE 3

(73-45) CODE GAUSSIAN CHANNEL DECODER EXPERIMENTAL RESULTS

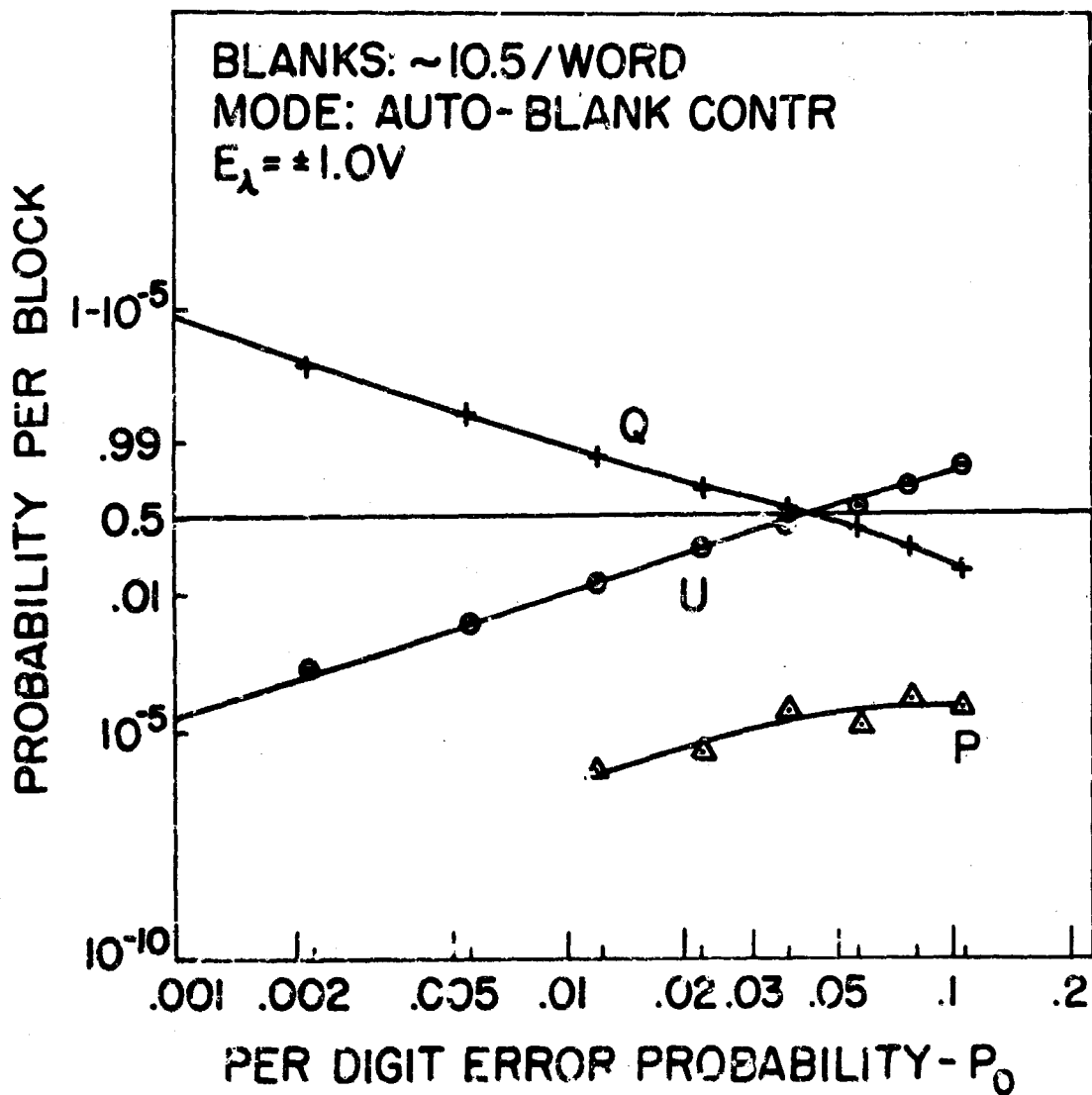

FIGURE 4

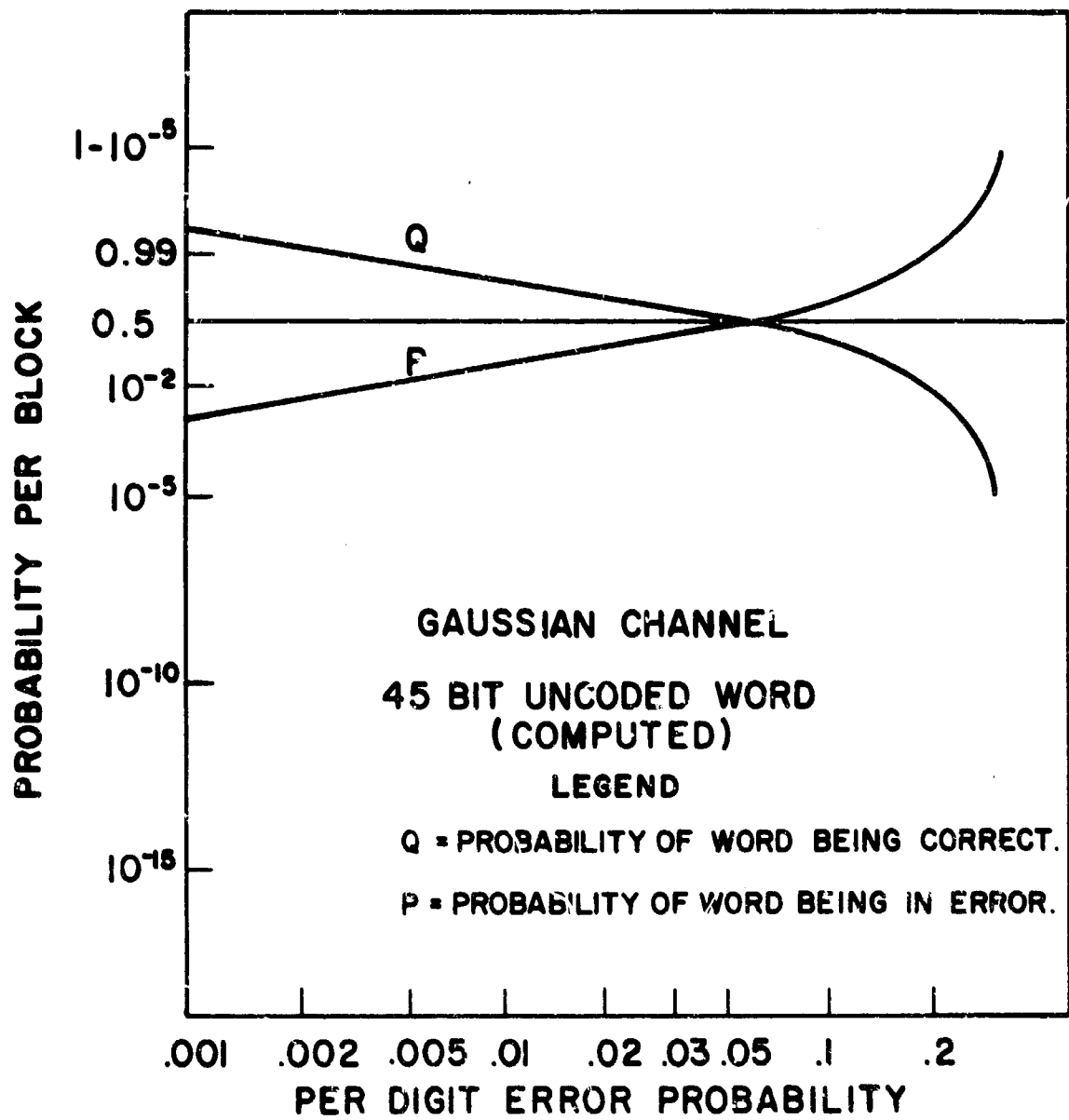

FIGURE 5

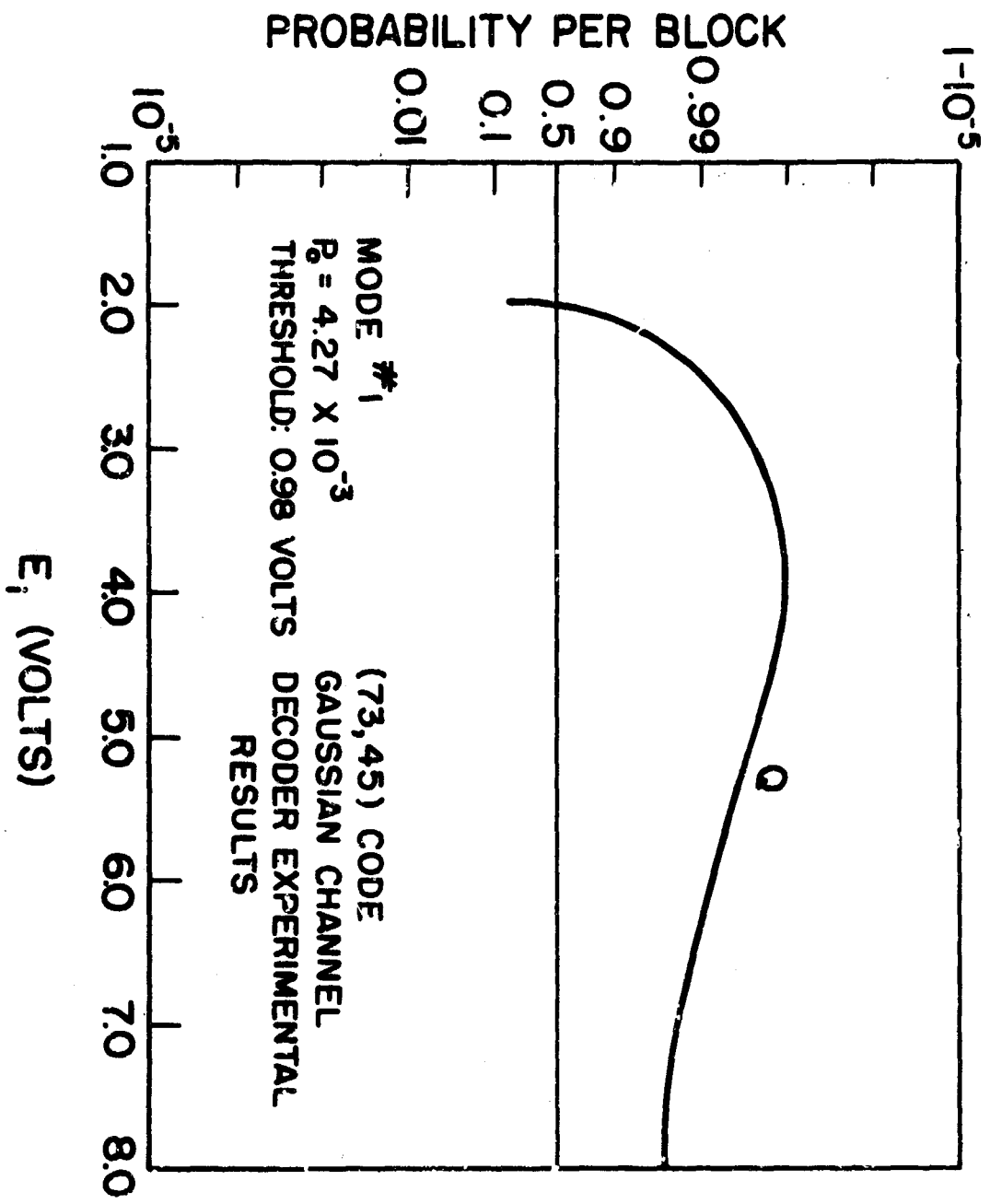

FIGURE 6

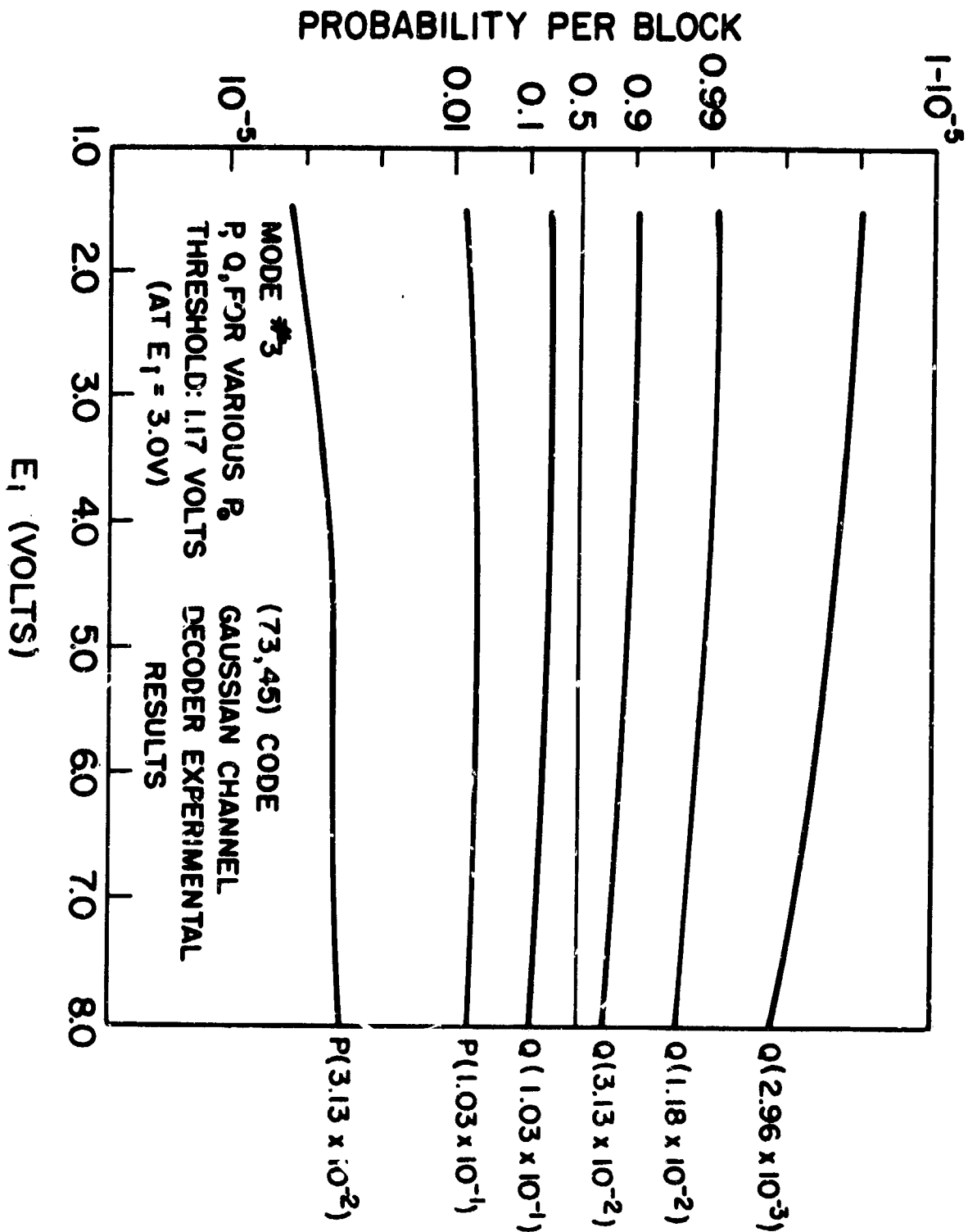

FIGURE 7

ENCODER

ENCODER
AUXILIARY

GAUSSIAN
R.F. CHANNEL
SIMULATOR

DECODER
AUXILIARY

DECODER

POWER
SUPPLY

LABORATORY MODEL
OF COMMUNICATION SYSTEM

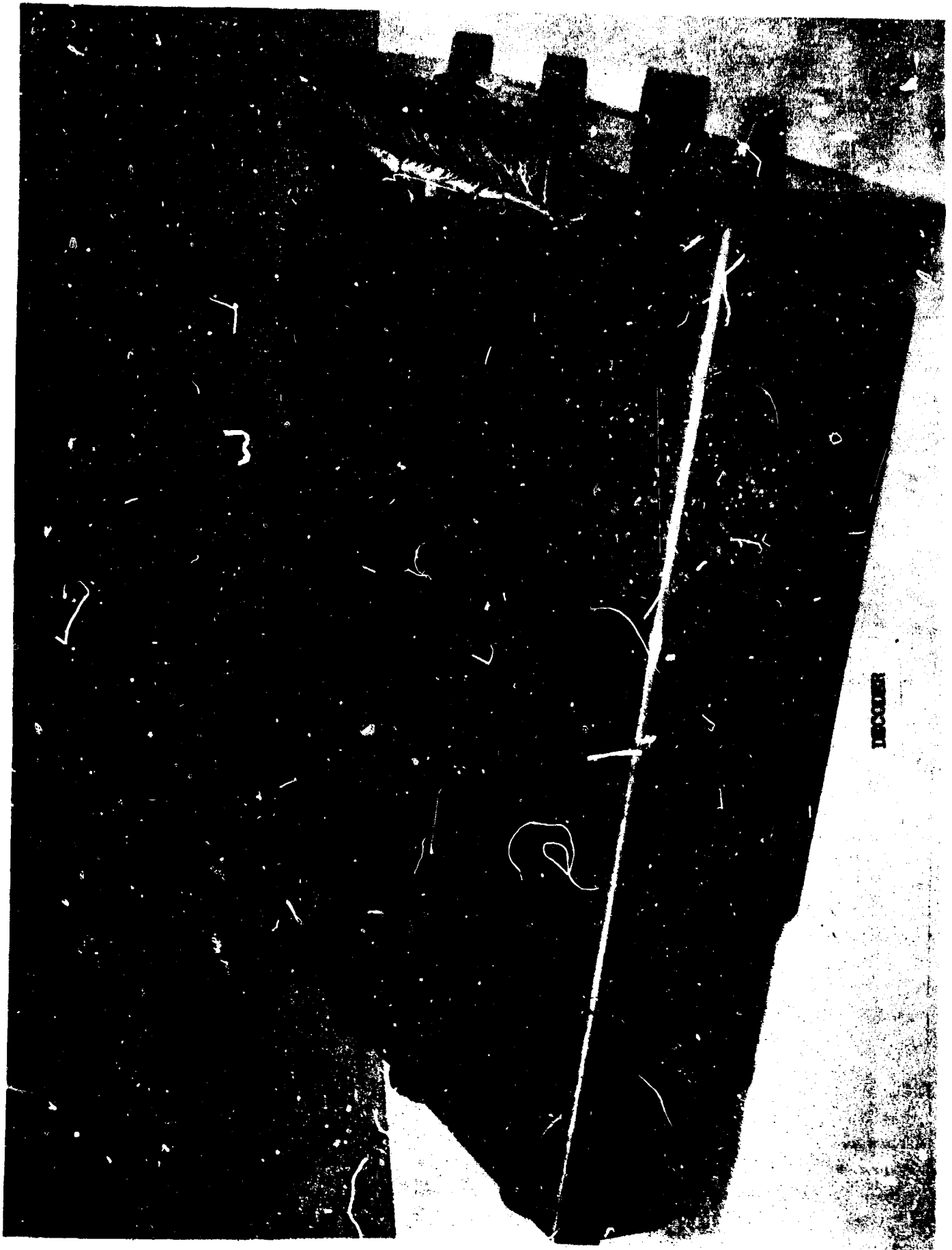

SECTION 6

FOURIER SPECTROSCOPY

The last decade has seen the rebirth of a multiplex technique for obtaining the power spectrum of radiation. This technique which is called Fourier spectroscopy (or the interferogram technique) was first used by Rubens and Wood in the far-infrared (100-300 μ) region of the spectrum. Rubens and Wood measured the flux $D(x)$ of infrared radiation reaching the central fringe of a two-beam interferometer as a function of path difference x between the beams. The function $D(x)$ contains a constant term and an oscillatory term; the latter term $F(x)$ is called the interferogram. An interferogram characterizes the incident spectrum that produces it, and can be analyzed to yield the unique spectral distribution of the radiation reaching the detector.

A slight variant of the above is the visibility technique introduced by Michelson to determine symmetric spectral profiles of lines which were not resolvable by grating or prism instruments. But whereas a visibility curve can only be analyzed to give a unique spectral distribution when the latter is known, a priori, to be symmetrical about a central frequency, the interferogram yields a unique spectrum.

Multiplex in telecommunication is a technique for simultaneously transmitting many messages over the same line. In spectroscopy, the term implies simultaneously detecting the energy of a broad spectral region of undispersed radiation with a single detector. The ordinary spectrograph simultaneously measures a broad spectral region of dispersed radiation using a photographic emulsion, but is not a multiplex system; it is more properly called a multichannel system. In multiplex spectroscopy, the intensity

of each spectral component of width $\zeta\sigma$ (the resolution of the instrument) of a broad spectrum is coded using an orthogonal code such that decoding may be simply accomplished. The specific orthogonal code of the simple harmonic functions sine and cosine is the one used in Fourier spectroscopy.

Since the method used in the program was this interferogram technique we shall now consider the deviation of the interferogram and the spectral distribution.

In the visibility technique, it was found that the information obtainable is the modules of the Fourier transform of the spectral distribution $B(\sigma)$. A recovery of the spectrum is possible only when $B(\sigma)$ is symmetric with respect to its central frequency. On the other hand, the output of a two beam interferometer consists of the real part of the Fourier transform of the spectral distribution $B(\sigma)$. Fourier spectroscopy utilizes all the information contained in the output of the interferometer.

The interferogram $F(x)$ is given by

$$\begin{aligned} F(X) &= D(X) - \int_{-\infty}^{\infty} B(\sigma) d\sigma \\ &= \int_{-\infty}^{\infty} B(\sigma) \cos 2\pi\sigma x d\sigma \\ &= \text{RE} \int_{-\infty}^{\infty} B(\sigma) e^{i2\pi\sigma x} d\sigma \end{aligned} \quad (1)$$

The spectral distribution $B(\sigma)$ is represented by two distributions extending over the entire frequency domain, negative and positive, although only the positive frequency domain has physical significance. Thus

$$B(\sigma) = B_e(\sigma) + B_o(\sigma) \quad (2)$$

The Fourier transform of $B(\sigma)$ is

$$\begin{aligned} \tilde{B}(X) &= \int_{-\infty}^{\infty} B(\sigma) e^{i2\pi\sigma x} d\sigma \\ &= \int_{-\infty}^{\infty} B(\sigma) \cos 2\pi\sigma x d\sigma + i \int_{-\infty}^{\infty} B(\sigma) \sin 2\pi\sigma x d\sigma \\ &= F(X) + i \mathcal{H}[F(X)] \end{aligned} \quad (3)$$

where $\mathcal{H}[F(X)]$ is the Hilbert transform of $F(X)$; i.e.,

with ρ signifying the Cauchy principal value.

Since we measure $F(X)$ only, and not $\tilde{B}(X)$, the Fourier transform of the measured function $F(X)$ gives the even distribution $Be(\sigma)$.

Using (2) we rewrite (3) to be

$$\tilde{B}(X) = \int_{-\infty}^{\infty} Be(\sigma) e^{i2\pi\sigma X} d\sigma + \int_{-\infty}^{\infty} B_o(\sigma) e^{i2\pi\sigma X} d\sigma \quad (5)$$

It is seen that the real part of $\tilde{B}(X)$, namely the interferogram, is given by

$$\begin{aligned} F(X) &= \int_{-\infty}^{\infty} Be(\sigma) e^{i2\pi\sigma X} d\sigma \\ &= \int_{-\infty}^{\infty} Be(\sigma) \cos 2\pi\sigma X d\sigma \end{aligned} \quad (6)$$

Consequently, the interferogram (which is necessarily real) corresponds to the distribution $Be(\sigma)$ and not $B(\sigma)$. The spectrum $Be(\sigma)$ is then given by an inverse transform

$$Be(\sigma) = \int_{-\infty}^{\infty} F(X) e^{-i2\pi\sigma X} dx \quad (7)$$

Since $Be(\sigma)$ is defined to be even about the origin, the interferogram $F(X)$ given by equation (6) is also an even function resulting in

$$\begin{aligned} Be(\sigma) &= \int_{-\infty}^{\infty} F(X) \cos 2\pi\sigma X dx \\ &= 2 \int_0^{\infty} F(X) \cos 2\pi\sigma X dx \end{aligned} \quad (8)$$

Thus the correct spectrum for positive frequencies is obtained through a cosine transformation of the interferogram. The contribution from negative frequencies in $Be(\sigma)$ however, must be taken into account since these exist mathematically.

Thus, the interferogram technique yields a unique spectrum through a cosine transformation, while Michelson's visibility technique determines a unique spectrum only if the spectrum is quasimonochromatic and the distribution is symmetric about a center frequency.

Project Number: 5710
Problem Number: 1637
Researcher: Mr. J. Cahill

SECTION 7

SPACE-CHARGE LIMITATION OF SECONDARY ELECTRON EMISSION CURRENTS IN SINGLE AND DOUBLE DIODES

In this project, the secondary electron emission (SEE) current from irradiated single and double diodes, whose electrodes are assumed to be identical, plane-parallel, of infinite extent and spaced a distance apart was investigated. If the radiation bombards one foil only, this classifies the system as a single diode; if both foils, the system constitutes a double diode. For the latter case we assume that both electrodes experience an identical dose rate of deposited energy causing their emission current densities (given as J_s) to be equal. However, in general, as was proved from the results of the computer programs, the net current density flowing between foils (given as J_c) will not be equal to J_s because of limitation by space-charge effects, and, in the double diode, by a retardation of some portion of the emission from the positive foil.

The problem involved in the programming was to determine J_c , given J_s , or vice-versa under known geometrical and electrical specification. The procedure for accomplishing this was initiated by showing how intimately related the SEE phenomenon is to thermionic electron emission (TEE). This is effected by hypothesizing a certain energy-angle density distribution of internal electrons and then demonstrating how such a distribution would lead to an external differential electron flux and electron phase-space density function which are identical in form to those derived for the TEE case. A comparison of all these forms reveals a one-to-one correspondence between certain SEE and TEE parameters. Consequently it turns out that the complete analytical solution to the SEE problem exactly parallels that for the TEE problem, as presented by Lindsay and Parker (1959).

Two important byproducts of the study are noted for the first time. One, it was established that the most significant parameter which really characterizes the system is the product d^2J_s , rather than any one individual term. Two, generalized graphs were presented indicating threshold voltage limits for both space-charge and partial retardation effects, as well as how d^2J_c varies with applied voltage (V), as based on the program calculations. These graphs will be of practical value to the experiments. For, by their use, he can immediately specify whether his single or double diode is operating within the space-charge limited, above upper threshold or below lower threshold regions. The equations used in the programs are given on the following pages.

Also compared were theoretically calculated retarding potential curves (normalized) J_c versus V, for fixed J_s to data derived from some AFCRL experiments, in which AL, TA, and AU double diodes were irradiated by 60 CO Y-rays and 10 MeV electrons.

PHASE I.

A. DOUBLE DIODE

For each value of V_{thr} solve for (d^2J_s) D.D. with V ranging from .01-100

$$(d^2J_s)D.D. = \frac{1}{(415)^2} \left[\int_0^{.402V_{thr}} \frac{du}{\sqrt{h+(u) + e^{-.402V_{thr}h-(u)}}} \right]^2$$

$$\text{where } h \pm (u) = e^u - 1 \pm 2 \left(\frac{u}{\pi}\right)^{1/2} + e^u \operatorname{erfc}\sqrt{u}$$

$$\text{and } \operatorname{erfc}\sqrt{u} = \frac{2}{\sqrt{\pi}} \int_{\sqrt{u}}^{\infty} e^{-z^2} dz$$

$$(d^2J_c)D.D. = (d^2J_s)D.D. [1 - e^{-.402V_{thr}}]$$

B. SINGLE DIODE

$$(d^2J_s)S.D. = \frac{1}{(415)^2} \left[\int_0^{.402V_{thr}} \frac{du}{\sqrt{h+(u)}} \right]^2$$

$$(d^2J_s)S.D.,L.T. = \frac{e}{(415)^2} \left[\int_0^{.402V_{thr}} \frac{du}{\sqrt{h-(u)}} \right]^2$$

$$(d^2J_c)S.D.,L.T. = (d^2J_s)S.D.,L.T. e^{-.402V_{thr}}$$

PHASE II.

A. DOUBLE DIODE

Given values of V and (d^2J_s) D.D., these 2 equations must be solved simultaneously to get β_0 and β_d .

$$(1) \quad \beta_d = .402V + \beta_0$$

$$(2) \quad (\beta_0^- + \beta_d^+)^2 = (415)^2 e^{-\beta_0} (d^2J_s) \text{D.D.}$$

$$\text{where } \beta_0^- = \int_0^{\beta_0} \frac{du}{\sqrt{h+(u) + e^{-.402V} h - (u)}}$$

$$\beta_d^+ = \int_0^{\beta_0} \frac{du}{\sqrt{h+(u) + e^{-.402V} h - (u)}}$$

and $h^\pm(u)$ are defined previously.

For each combination of V and (d^2J_s) D.D.

$$(d^2J_c) \text{D.D.} = (d^2J_s) \text{D.D.} e^{-\beta_0} [1 - e^{-.402V}]$$

B. SINGLE DIODE

Given values of V and (d^2J_s) D.D., these 2 equations must be satisfied simultaneously to get β_0 and β_d .

$$(1) \quad d = .402 V + \beta_0$$

$$(2) \quad (\xi_0^- + \xi_d^+)^2 = (415)^2 e^{-\beta_0} (d^2J_s) S.D.$$

where

$$\xi_0^- = \int_0^{\beta_0} \frac{du}{\sqrt{h - (u)}}$$

$$\xi_d^+ = \int_0^{\beta_d} \frac{du}{\sqrt{h + (u)}}$$

For each combination of V and (d^2J_s) D.D.

$$(d^2J_c) S.D. = (d^2J_s) S.D. e^{-\beta_0}$$

Project Number: 5710

Problem Number: 1677

Researcher: Mr. P. Gianino

SECTION 8
CONTRIBUTORS

The writers express their thanks to Miss Eunice C. Cronin, Analysis and Simulation Branch (CRMCA), AFCRL Computation Center, Air Force Cambridge Research Laboratories, whose technical guidance and experience was invaluable in the preparation of this report and Mr. Vincent Mazzio, Analysis and Simulation Branch (CRMCA), AFCRL Computer Center, Air Force Cambridge Research Laboratories, Contract Monitor, whose contribution was of prime importance in the preparation of this report.

In addition, the authors would like to thank the following AFCRL research personnel who provided valuable information for preparation of this report.

Mr. R. Allen

Mr. P. Gianino

Lt. J. Brazy

Dr. R. A. McClatchy

Mr. J. Cahill

Lt. A. Slobodnik, Jr.

SECTION 9

REFERENCES

1. Gates, D. M., Calfee, R. F., Hansen, D. W., and Benedict, W. W., 1964, Line Parameters and Computed Spectra for Water Vapor Bands at 2.7 MICRONS NBS MONOGRAPH 71.
2. Benedict, W. S., and Calfee, R. F., Line Parameters for the 1.9 and 6.3 MICRON WATER VAPOR BANDS, 1967 ESSA PROFESSIONAL PAPER 2.
3. Drayson, S. R., and Young, C. 1967, THE FREQUENCIES AND INTENSITIES OF CARBON DIOXIDE ABSORPTION LINES BETWEEN 12 and 18 MICRONS, UNIVERSITY OF MICHIGAN TECHNICAL REPORT under ESSA Contract No. CW3-11376.
4. Clough, S. A., and Kneizys, F. X., Ozone Absorption in the 9.0 MICRON REGION 1965, AFCRL 65-862.
5. Hobbs, C. F. Notes on Evaluation of Experimental Decoder, Appendix Section 5 Scientific Report, AFCRL.

Unclassified

Security Classification

DOCUMENT CONTROL DATA - R&D		
<i>(Security classification of title, body of abstract and indexing annotation must be entered when the overall report is classified)</i>		
1. ORIGINATING ACTIVITY <i>(Corporate author)</i> Analysis & Computer Systems, Inc. Building 6, Second Ave., Northwest Park Burlington, Massachusetts 01803		2a. REPORT SECURITY CLASSIFICATION Unclassified
		2b. GROUP
3. REPORT TITLE MATHEMATICAL RESEARCH AND COMPUTER ORIENTED ATMOSPHERIC STUDIES		
4. DESCRIPTIVE NOTES <i>(Type of report and inclusive dates)</i> Scientific. Final. December 1968 through December 1969 Approved		
5. AUTHOR(S) <i>(First name, middle initial, last name)</i> Donald J. Armstrong Carolyne M. Mandell Raymond J. Arsenault Alan P. Truesdale		
6. REPORT DATE December 1969	7a. TOTAL NO. OF PAGES 87	7b. NO. OF REFS 5
8a. CONTRACT OR GRANT NO. F19628-69-C-0095	9a. ORIGINATOR'S REPORT NUMBER(S)	
b. PROJECT, TASK, WORK UNIT NOS. n/a n/a n/a		
c. DOD ELEMENT 61102F	9b. OTHER REPORT NO(S) <i>(Any other numbers that may be assigned this report)</i>	
d. DOD SUBELEMENT 681300	AFCL-70-0138	
10. DISTRIBUTION STATEMENT This document has been approved for public release and sale, its distribution is unlimited.		
11. SUPPLEMENTARY NOTES TECH, OTHER	12. SPONSORING MILITARY ACTIVITY Air Force Cambridge Research Laboratories (CRM) L. G. Hanscom Field Bedford, Massachusetts 01730	
13. ABSTRACT This report is the concluding scientific report to record the status and progress of Scientific Analytical Investigations, the preparation of Computer Programs, Data Reduction, and the development of mathematical and computer techniques in support of Environmental Research and other various aspects of the physical sciences concerning the upper atmosphere. During the year covered by this report, the 20 completed programs ranged in complexity and size from conversion of programs from one language or computer system to another, to analysis and development of a large system of analytical programs.		

DD FORM 1473
1 NOV 68

Unclassified

Security Classification

Unclassified

Security Classification

14. KEY WORDS	LINK A		LINK B		LINK C	
	ROLE	WT	ROLE	WT	ROLE	WT
Edit System Solar Observation Gauss Elimination Surface Wave Propagation Microwave Acoustics Piezoelectric Crystals Atmospheric Transmittance Spectroscopic Parameters Decoding Algorithms Fourier Spectroscopy Power Spectrum of Radiation Interferogram Single and Double Diodes Secondary Electron Emission Currents Water Vapor Bands						

Unclassified

Security Classification