

AD704755

FOREIGN TECHNOLOGY DIVISION



THE POSSIBILITY OF USING THE TRANSPARENCY METHOD
TO DETERMINE THE MICROSTRUCTURE
OF AN ATMOSPHERIC AEROSOL

by

V. G. Bakhtiyarov

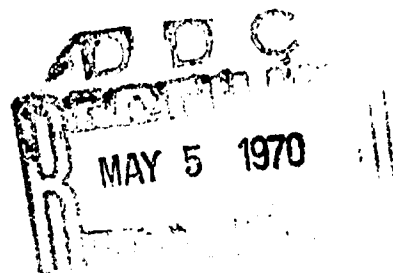
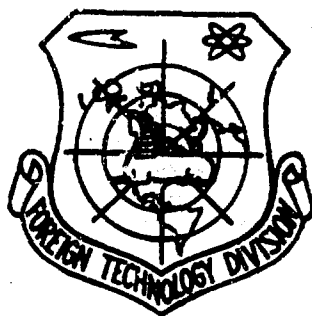

Distribution of this document is unlimited. It may be released to the Clearinghouse, Department of Commerce, for sale to the general public.

EDITED TRANSLATION

THE POSSIBILITY OF USING THE TRANSPARENCY
METHOD TO DETERMINE THE MICROSTRUCTURE OF
AN ATMOSPHERIC AEROSOL

By: V. G. Bakhtiyarov

English pages: 12

Source: Nalchik. Vysokogornyy
Geofizicheskiy Institut, Trudy
(Nalchik. Alpine Geophysical
Institute. Transactions),
No. 8, 1968, pp. 41-48.

Translated by: D. Koolbeck/TDBRS-3

UR/3213/68/000/008

THIS TRANSLATION IS A RENDITION OF THE ORIGINAL FOREIGN TEXT WITHOUT ANY ANALYTICAL OR EDITORIAL COMMENT. STATEMENTS OR THEORIES ADVOCATED OR IMPLIED ARE THOSE OF THE SOURCE AND DO NOT NECESSARILY REFLECT THE POSITION OR OPINION OF THE FOREIGN TECHNOLOGY DIVISION.

PREPARED BY:

TRANSLATION DIVISION
FOREIGN TECHNOLOGY DIVISION
WP-AFB, OHIO.

THE POSSIBILITY OF USING THE TRANSPARENCY METHOD
TO DETERMINE THE MICROSTRUCTURE
OF AN ATMOSPHERIC AEROSOL

V. G. Bakhtiyarov

Difficulties in Using the Transparency Method
in the Atmosphere

The transparency method, which makes it possible to calculate the spectra of the particles of a dispersed system according to optical information, has been used earlier only in laboratory conditions. In this work we consider the possibilities of using the method in the free atmosphere.

Recently the study of the atmospheric aerosol, i.e., particles of microscopic and submicroscopic size in the atmosphere, has taken on ever greater importance. In connection with this it is necessary to examine the question of the possibility of applying the studied method to determine the dimensions of particles of an atmospheric aerosol.

In order to determine particle dimensions by the transparency method it is necessary to find the polydispersion coefficient of scattering of the system in a significant range of wavelengths, i.e., to determine the transparency of the atmosphere in a certain spectral interval.

The accepted view of the atmosphere is that of a medium consisting of a mixture of gases, water vapor, and extremely fine dispersed

particles - aerosols. The general attenuation of radiation in the atmosphere occurs through two basic processes: absorption by gaseous components and scattering.

Thus the attenuation of radiation in the atmosphere can be presented in the form

$$Q(\lambda) = \gamma(\lambda) + \alpha(\lambda), \quad (1)$$

where $\alpha(\lambda)$ is the attenuation due to scattering and $\gamma(\lambda)$ is the fundamental absorption of the atmosphere.

The dependence of γ on wavelength λ represents a series of lines, bands, and systems of bands of absorption in the ultraviolet, far red, and infrared spectral regions. The fundamental absorption by the atmosphere is caused by the presence of water vapor, carbon dioxide, ozone, etc., all of which have powerful absorption bands.

Water vapor is the most effective absorbing component; its content in the atmosphere can be sharply varied, depending upon a whole series of factors such as temperature, pressure, etc., [1]. The major quantity of water vapor is concentrated at altitudes up to 5 km. Therefore when determining the transparency of an atmospheric aerosol it is necessary to know all the spectral intervals in which absorption of radiation by water vapor is essential. Table 1 shows the basic absorption bands of water vapor in the near infrared region of the spectrum. The strongest absorption bands are centered at the wavelengths 1.38, 1.87, 2.7, and 6.3 μm .

Another absorbing component of the atmosphere is carbon dioxide, which is usually found in the atmosphere in smaller quantities than water vapor. Carbon dioxide possesses several absorption bands in the infrared region of the spectrum, located in the wavelength region $\lambda > 2 \mu\text{m}$.

Intensive absorption bands in the infrared region are caused by vibration transitions, where only vibrations with frequencies of

$\nu_1 = 673 \text{ cm}^{-1}$ and $\nu_2 = 2378 \text{ cm}^{-1}$ are active in absorption. The indicated basic frequencies reflect two intensive absorption bands - near 4.3 and 14.7 μm . Besides these basic bands, CO_2 absorption bands centered at wavelengths 2.7 and 10 μ and a number of other weak bands are also detected. Table 1 gives all significant absorption bands for CO_2 .

Table 1

designation of band	Absorption bands				Transparency window, μm 0.95 - 1.05
	water vapor		CO_2		
	spectral region, μm	band center, μm	band center	width of band, cm^{-1}	
α	0.70-0.74	0.718	1.4	6650-7250	1.2-1.3
β	0.79-0.84	0.810	1.6	6000-6550	1.5-1.8
γ	0.926-0.978	0.935	2.0	4750-5200	2.1-2.4
δ	1.095-1.165	1.130	2.7	3480-3800	3.3-4.2
ϵ	1.319-1.498	1.395	4.3	2160-2500	4.5-5.0
ζ	1.762-1.977	1.870	4.8	1980-2100	8-13
η	2.520-2.845	2.680	5.2	1870-1980	
3.2 μm	2.990-3.570	3.2	14.7	550-800	
6.3 μm	4.800-8.690	6.3			

During measurements of the spectral transparency of an atmospheric aerosol it is also necessary to take into account absorption of short-wave radiation by ozone, whose concentration shows a rather unique variation with altitude: it increases sharply at altitudes of 22-27 km and is reduced virtually to zero at altitudes above 40 km. Observations carried out in natural and laboratory conditions have shown that ozone has several absorption bands in the solar radiation region of the spectrum, with the most intensive absorption band in the ultraviolet section of the spectrum, i.e., 2200-3200 Å. In the infrared region of the spectrum under atmospheric conditions only a narrow but intensive band at 9.6 μm is observed clearly. The remaining ozone absorption bands are overlapped by more intensive absorption bands of water vapor and carbon dioxide. All of the ozone absorption bands are manifested clearly only under the condition that the source of radiation be located outside the terrestrial atmosphere (Sun, Moon, stars). If the source of radiation is located in layers of the atmosphere below 15 km, absorption by ozone will be very insignificant. Consequently,

during determination of the transparency of an atmospheric aerosol with an artificial radiation source the influence of ozone absorption can be ignored.

Thus, the considered absorption bands create the so-called picture of absorption of radiation by the atmosphere, a picture which changes depending upon the concentration and state of the individual absorbing components. In designing optical and electronic instruments it is extremely important to note the presence of "windows" of atmospheric transmission (see Table 1).

The changes which occur in the concentrations of the absorbing components of the atmosphere make it necessary to modify the methods used to calculate the absorption coefficient during distribution of radiation in nonhorizontal directions. Such methods have been developed for several cases which are important in the practical respect. For example, the method of effective absorbing mass is applied for the case of a beam of pressure which is constant in direction [2].

Scattering of radiation arises in those cases when the medium is nonuniform, i.e., scattering occurs in the presence of spatial inhomogeneity of the dielectric constant. In atmospheric conditions the basic factors which determine scattering are fluctuations in the density of the air and the presence of aerosol particles (drops of water, dust particles, etc.). According to the work by Rayleigh [3], for the coefficient of molecular scattering we will have

$$k_p = \frac{32\pi}{3N\lambda^4} \sum_i v_i (m_i - 1)^2 \left(\frac{2 + \rho_i}{2 - \rho_i} \right). \quad (2)$$

where m_i is the refractive index for the i -th gas under normal conditions, N is the number of molecules per unit volume, v_i is the partial volume of the i -th gas in air, and ρ_i is the coefficient of depolarization of the given gas. The values of the coefficients of molecular scattering for individual wavelengths were calculated by R. Penndorf [4].

Analysis of the data given in [4] shows that molecular scattering can, for practical purposes, be ignored in the infrared region of the spectrum. This factor must be taken into account in the visible region of the optical spectrum.

However, molecular scattering is not the principal factor in the scattering of radiation in the atmosphere. Here there is always a process connected with scattering on the aerosol component of the atmosphere - the most variable portion of the atmosphere. Thus, according to the works by S. F. Rodionov [5], T. P. Toropova [6], and others, scattering on aerosols is comparable with the magnitude of molecular scattering of radiation even in the absence of fog and noticeable smoke. In a turbid atmosphere, i.e., in the presence of smoke, scattering on aerosols is the principal factor operating to attenuate radiation, so that molecular scattering is negligibly small in comparison with it. Foitzik [7] investigated the dependence of the polydisperse coefficient of scattering on the size and number of particles of a dispersed system. He found that this relationship carries a spectral character. Thus, all investigations which have been carried out attest to the fact that the transparency method can be applied to determine the dimensions of particles of a natural aerosol. From work [8] it is clear that the transparency method is suitable for application to disperse systems of particles with $r < 5 \mu\text{m}$ (in real conditions this would be atmospheric dust and smoke). The limited nature of application of the transparency method to disperse systems of smoke and dust is explained by the fact that determination of dimensions of particles with $r > 5 \mu\text{m}$ requires knowledge of the polydisperse coefficient of scattering in a comparatively far infrared region. Working with such a spectral interval in the real atmosphere is connected with major difficulties, both in principle and from the technical point of view.

Measurements of the Transparency of an Atmospheric Aerosol

Any measurement of the transparency of a certain layer of the atmosphere in the horizontal direction normally reduces to comparison of the intensity of radiation which has passed through the layer with

the intensity of the incident radiation or, in general, with the radiation of a certain source, yielding a comparison spectrum. The complexity of experiments of this type for the visible, near ultraviolet, and infrared regions is determined by the necessity of utilizing long paths, traversed by the beam, because of the great transparency of air. Selection of the magnitude of the working route depends essentially on the sensitivity of the receiver, since it is necessary to deal with comparatively small changes in the intensity of radiation caused by scattering on the natural aerosol. During study of the dynamics of processes occurring in aerosols the working path is selected as a constant, usually equal to 5-10 km. It is desirable that the path be at as great a distance as possible from the surface of the Earth, in order to eliminate random changes in the optical state of the route.

Determination of transparency $g^*(\nu^*)$ can be carried out as follows. A flux of radiation from a source located in the focus of the sending mirror passes through a layer of the atmosphere and upon being reflected from the return mirror arrives at the receiving mirror, which directs the flow of radiation to the input slot of a monochromator. After dispersion the monochromatic beam is directed to the sensing surface of the receiver. The amplified signal of a wide-band amplifier is detected and is measured by a recording device. Another light flux (control beam) which has not been subjected to attenuation on aerosols is directed by a system of concave spherical mirrors from the same source onto the input slit of the monochromator. The ratio of intensity of the first beam to the second is proportional to the transmission. An advantage of this circuit is the fact that it makes it possible to arrange the source of radiation close to the receiving device and to use the given source of radiation for the control signal.

The intensity of radiation which has passed through an atmosphere containing an aerosol is determined by the formula

$$I_1 = I_0 e^{-Ql}, \quad (3)$$

where I_1 is the intensity of radiation after passage along path l and I_0 is the intensity of the same source in direction l .

The intensity of the control signal equals

$$I_2 = I_0 e^{-Ql}. \quad (4)$$

The distance $l_1 \ll l$ is selected in such a manner that scattering on the aerosol can be considered to be absent. Taking into account the loss of intensity of radiation during reflection from the mirror, we will rewrite (3) and (4) in the form

$$I_1 = r_n I_0 e^{-Ql}, \quad (5)$$

$$I_2 = r'_n I_0 e^{-Ql}, \quad (6)$$

where r_n and r'_n characterize the loss of intensity of radiation on the path l and l_1 due to reflection.

Solving (5) and (6) simultaneously, we obtain

$$Q = \left(\frac{\ln \frac{I_2}{I_1}}{l - l_1} + \frac{\ln \frac{r'_n}{r_n}}{l - l_1} \right) \approx \frac{1}{l} \ln \frac{I_2}{I_1} + \Delta. \quad (7)$$

Here a preliminary study of the dependence of r_n and r'_n on wavelength is indicated. Thus the given method makes it possible to determine the magnitude of attenuation of radiation with an accuracy up to a certain constant Δ .

If the measurement of intensity is conducted at the terminal and intermediate points, it will be possible to determine the scattering of radiation by an aerosol which is located between these points. Here one should take into account the fact that if a source is a point source the reduction in measurable intensity of radiation with distance from the source occurs not only as the result of absorption and scattering, but basically is a consequence of a drop in intensity by the law of inverse squares. Calculation of this type of attenuation requires the application of neutral filters which will compensate attenuation due to distance [9].

Measurements conducted in this way make it possible to determine attenuation of radiation Q on a section of the path from the intermediate to the end points, i.e.,

$$Q = k_p + g^*(v^*). \quad (8)$$

By calculating the values of k_p by the Rayleigh formula (2), we will be able to determine the value of the polydisperse coefficient of scattering.

If the source of radiation is the Sun the coefficient of attenuation is determined according to the formula.

$$Q = \frac{\ln I_{z_1} - \ln I_{z_2}}{m_{z_1} - m_{z_2}}. \quad (9)$$

where $m_{z_2} - m_{z_1}$ represents the difference of atmospheric masses between the observation points; I_{z_1} and I_{z_2} are the monochromatic fluxes of direct solar radiation at the two altitudes z_1 and z_2 for a given zenith distance. The difference in atmospheric masses, $m_{z_1} - m_{z_2}$, is determined according to the Bemporad table with a correction for pressure.

Thus, by applying one of the methods outlined above we are able to determine the spectral path of the polydisperse coefficient of scattering, knowledge of which is necessary for calculation of the spectrum of dimension of particles of a dispersed system by the transparency method.

The examined methods of determining the polydisperse coefficient of scattering $g^*(v^*)$ assumed that the spectral measurements are conducted outside the bands of absorption by the gaseous components of the atmosphere. In the opposite case it is necessary to introduce a correction for absorption, and since water vapor is the most variable and the strongest absorbing component, in the course of the experiment it is necessary that data on absolute humidity be available.

During measurement of the quantity $g^*(v^*)$ it should be remembered that formula (3) is valid for attenuation of intensity in a direction directly ahead of I_1 . However, radiation which has been scattered from the side will be incident on the receiving area; this is connected with the angular dimensions of the photometer. We shall consider that only the role of once-scattered radiation is great. We shall designate as θ the cone angle of radiation of the source, and ψ will be used to designate the aperture angle of the receiver. Then for the intensity of single [scattered] radiation we can write

$$I_2 = \frac{QI_0}{4\pi} \iint \frac{1}{r_1 r_2} e^{-Q(r_1+r_2)} \beta(\theta) \cos \psi \, d\nu, \quad (10)$$

where $\beta(\theta)$ is the indicatrix of scattering and r_1 and r_2 are the distances from the elementary scattering volume to the source and to the receiver, respectively.

For the total intensity recorded by the receiver we have

$$I = I_1 + I_2 = \frac{I_0 e^{-Qr}}{r^2} (1 + QrC), \quad (11)$$

$$C = \frac{1}{2} \int_0^\psi \int_0^\theta \beta(\psi + \theta) \cos \psi \, d\psi \, d\theta.$$

From (11) it follows that for specific experimental conditions Q and C can be obtained by relative measurements of I for three receiver - source distances.

Device for Automatic Computation of the Distribution Function

In practice cases are encountered when it is necessary to know the distribution of particles with respect to dimensions immediately after measurement of the spectral transparency of a disperse system. Calculation of the curve of particle distribution with respect to dimensions, $f(r)$, can be significantly accelerated if we introduce automation of the computation process according to the equations

$$m(a) = -\frac{1}{\pi} \left\{ \Delta x \sum_{j=1}^m g\left(\frac{x_j}{2}\right) \omega(ax_j) + C_0 \omega_0(a\tau) + \frac{C_1}{\tau} \omega_1(a\tau) \right\}. \quad (12)$$

$$f(r) = \frac{m(a)}{2\pi a^2 r_0^4}. \quad (13)$$

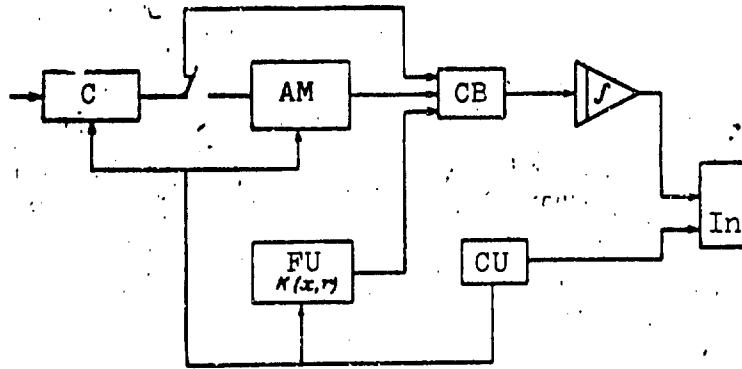

Fig. 1. Block diagram of calculation device.

This is accomplished by means of digital or other analogous computer technology. Together with LITMO [Leningrad Institute of Precision Mechanics and Optics] we conducted such a study, as a result of which we developed a computer for calculating the spectrum of particles by the transparency method. The block diagram of such a device for calculating the function $f(r)$ is shown on Fig. 1. After conversion into $g(x/2)$ in block C, the experimental function $I(\lambda)$ is passed to the converter block CB either directly or through the analog memory AM. The kernel $\omega(ax)$ is passed to the converter block from functional unit FU simultaneously with $g(x/2)$. The product $g(x/2)\omega(ax)$ obtained in the CB passes to the integrator, which develops the unknown function $f(r)$ in the form of a set of values fixed by integrator In. Control unit CU provides the following: synchronization of input $g(x/2)$ and reproduction of $\omega(ax_j)$, setting x_j , and control of the integration cycle duration by changing the scale of the rate of input of experimental information.

Thus, obtaining the spectrum of particle distribution with respect to dimensions, $f(r)$, is connected with multiple use of the experimental information. A special analog computer realizes relationships (12) and (13) in accordance with the block diagram shown on Fig. 1. By

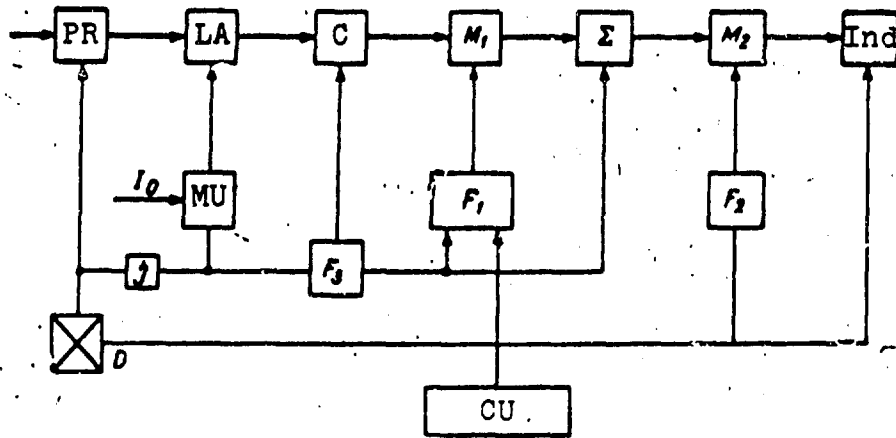

Fig. 2. Schematic diagram of an analog computer.

means of photoreceiver PR (Fig. 2) intensity $I(\lambda)$ of the flow of radiation is converted to a voltage which varies according to the argument λ which is introduced from pickup D.

The obtained function $I(\lambda)$ is fed to logarithmic amplifier LA. As a second factor, the quantity $I_0(\lambda)$ is fed to the LA from memory unit MU. The obtained value $g(\lambda)$ is fed to converter C, where transition to $g(x/2)$ is accomplished. The obtained value of $g(x/2)$ is fed to multiplier device M_1 , to the second input of which the value $R(x, r)$ of the exact solution of equation (12) is fed from functional F_1 . The product $g(x/2)R(x, r)$ obtained at the output of multiplier unit M_1 is integrated with respect to x in device Σ . After division of a generated value $\int_0^r g(\frac{x}{2})R(xr)dx$ by r^2 the ordinate $f(r)$ of the unknown curve of particle distribution is obtained in unit M. The magnitude of this ordinate is recorded for each discrete value of r by indicator Ind. As the result of multiple repetition of the described process for each value of r in the range of particle dimensions of interest, the point curve $f(r)$ characterizing the distribution of particles of the polydisperse medium under investigation is obtained on the indicator. Control unit CU ensures matching of the work of all circuits in the computer and, depending on the specific structure of the device, can fulfil various functions. The total time for calculation of the spectrum depends on the computation means and the speed of information input; it does not exceed 10 minutes.

Thus, the existence of a high-speed instrument and a computer device permits operational calculation of the curve of distribution of particles with respect to size.

References

1. Howard, J. H., D. E. Burch, and H. T. Williams. Near infrared transmission through synthetic atmosphere. Contract. Ohio University, 1955.

2. Shifrin, K. S., and N. P. Pyatovskaya. Tablitsy naklonnoy dal'nosti vidimosti i yarkosti bezoblachnogo neba (Tables of oblique range of visibility and brightness of a cloudless sky). Gidrometeoizdat, L., 1959.

3. Rayleigh, L. Proc. Roy. Soc., 97, 435, 1920.

4. Penndorf, R. Tables of the reflective index for standard air and the Rayleigh scattering coefficient for the spectral region between 0.2 and 20.0 μ and their application to atmospheric optics. JOSA, 47, 2, 1957.

5. Rodionov, S. F. Prozrachnost' atmosfery v ul'trafiol'etovoy oblasti spektra. Prozrachnost' tumanov v razlichnoy oblasti spektra. Avtoreferat dissertatsii (Transparency of the atmosphere in the ultra-violet spectral region. Transparency of clouds in different regions of the spectrum. Author's abstract of dissertation). FIAN, 1941.

6. Toropova, T. P. Opredeleniye kolichestva vodyanogo para, sodержashchegosya v atmosfere, spektral'nym metodom (Determination of the quantity of water vapor in the atmosphere by the spectral method).

7. Foitzik, L. Zur meteorogischen Optik von Dunst und Nebel (Meteorological optics of haze and fog). Zeitschr. für Met. Bd 4, H. 10, 11, 1950.

8. Bakhtiyarov, V. G. Nekotoryye rezul'taty eksperimental'noy proverki metoda rascheta spektra chastits dispersnoy sistemy po eye prozrachnosti (Some results of experimental verification of the method of calculating the spectrum of particles of a disperse system by its transparency). Tr. GGO, Issue 183, 1966.

9. Curcio, J. A., et al. An experimental study of atmospheric transmission. JOSA, 43, 2, 1953.

UNCLASSIFIED

Security Classification

DOCUMENT CONTROL DATA - R & D

(Security classification of title, body of abstract and indexing annotation must be entered when the overall report is classified)

1. ORIGINATING ACTIVITY (Corporate author) Foreign Technology Division Air Force Systems Command U. S. Air Force	2a. REPORT SECURITY CLASSIFICATION UNCLASSIFIED 2b. GROUP
---	--

3. REPORT TITLE
 THE POSSIBILITY OF USING THE TRANSPARENCY METHOD TO DETERMINE THE MICROSTRUCTURE OF AN ATMOSPHERIC AEROSOL

4. DESCRIPTIVE NOTES (Type of report and inclusive dates)
 Translation

5. AUTHOR(S) (First name, middle initial, last name)
 Bakhtiyarov, V. G.

6. REPORT DATE 1968	7a. TOTAL NO. OF PAGES 12	7b. NO. OF REFS 9
------------------------	------------------------------	----------------------

8a. CONTRACT OR GRANT NO. b. PROJECT NO. 72301-78 c. d.	9a. ORIGINATOR'S REPORT NUMBER(S) FTD-HT-23-97-70 9b. OTHER REPORT NO(S) (Any other numbers that may be assigned this report)
--	---

10. DISTRIBUTION STATEMENT
 Distribution of this document is unlimited. It may be released to the Clearinghouse, Department of Commerce, for sale to the general public.

11. SUPPLEMENTARY NOTES	12. SPONSORING MILITARY ACTIVITY Foreign Technology Division Wright-Patterson AFB, Ohio
-------------------------	---

13. ABSTRACT
 A discussion is presented on the application of the visibility method in calculating the spectra of the particles in a dispersed system in the free atmosphere, i.e., to determine the size spectra of atmospheric aerosols. The first section of the paper deals with the difficulties encountered in using the method, i.e., determination of the polydispersed scattering coefficient for the significant IR and short wavelengths, in an atmosphere in which radiation is attenuated by absorption by gaseous components and by scattering, and along both off-vertical and horizontal paths. Results obtained by both American and Soviet specialists are compared. The second section deals with problems encountered in making actual horizontal measurements of atmospheric aerosol visibility in the visible, near UV, and IR ranges over paths 5-10 km above the earth. A procedure is presented for determining visibility. The flux of radiation from a source located in the focus of the first mirror passes through the atmospheric layer. (Orig. art. has: 2 figures, 1 table and 13 formulas.) (AT8032277)

UNCLASSIFIED

Security Classification

14.	KEY WORDS	LINK A		LINK B		LINK C	
		ROLE	WT	ROLE	WT	ROLE	WT
	Atmospheric Optics Biologic Aerosol Atmospheric Visibility						

UNCLASSIFIED

Security Classification