

AD708443

FTD-MT-24-39-70

FOREIGN TECHNOLOGY DIVISION



PRINCIPLES OF THE PRODUCTION OF LIQUID-PROPELLANT ROCKET ENGINES

by

I. I. Gorev

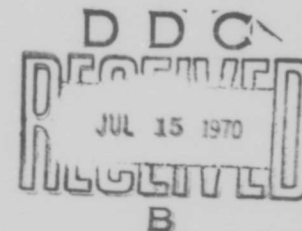

Distribution of this document is unlimited. It may be released to the Clearinghouse, Department of Commerce, for sale to the general public.

Reproduced by the
CLEARINGHOUSE
for Federal Scientific & Technical
Information Springfield Va. 22151

EDITED MACHINE TRANSLATION

PRINCIPLES OF THE PRODUCTION OF LIQUID-
PROPELLANT ROCKET ENGINES

By: I. I. Gorev

English pages: 398

Source: Osnovy Proizvodstva Zhidkostnykh
Raketnykh Dvigatelyey, Izd-vo
"Mashinostroyeniye," Moscow,
1969, pp. 1-356.

This document is a Mark II machine aided trans-
lation, post-edited for technical accuracy by:
Robert D. Hill.

UR/0000-69-000-000

THIS TRANSLATION IS A RENDITION OF THE ORIGINAL FOREIGN TEXT WITHOUT ANY ANALYTICAL OR EDITORIAL COMMENT. STATEMENTS OR THEORIES ADVOCATED OR IMPLIED ARE THOSE OF THE SOURCE AND DO NOT NECESSARILY REFLECT THE POSITION OR OPINION OF THE FOREIGN TECHNOLOGY DIVISION.

PREPARED BY:

TRANSLATION DIVISION
FOREIGN TECHNOLOGY DIVISION
WP-478, OHIO.

TABLE OF CONTENTS

U. S. Board on Geographic Names Transliteration System.....	111
Designations of the Trigonometric Functions.....	iv
Preface.....	vii
Introduction.....	ix
PART I. Manufacture of Combustion Chambers.....	1
Chapter 1. Design Configurations of Combustion Chambers and the Division into Technological Subassemblies.....	2
Chapter 2. Methods of Obtaining Thin-Walled Billets of Parts of Combustion Chambers.....	6
Chapter 3. Mechanical Treatment of Parts of the Combustion Chamber.....	32
Chapter 4. Assembly of Subassemblies of the Combustion Chamber.....	46
Chapter 5. Welding of Parts and Subassemblies of the Combustion Chamber.....	55
Chapter 6. Brazing of Subassemblies of the Combustion Chamber.....	91
Chapter 7. Manufacture of Injector Heads.....	122
Chapter 8. Assembly of Combustion Chambers.....	150
PART II. The Manufacture of Frames and Pipelines.....	163
Chapter 9. The Manufacture of Frames.....	164
Chapter 10. Manufacture and Test of Rigid Pipelines.....	173
Chapter 11. Manufacture of Flexible Pipelines.....	189
PART III. Manufacture of Basic Parts of Turbopump Units.....	201
Chapter 12. Treatment of Shafts.....	202
Chapter 13. Treatment of Disks of Turbines.....	228
Chapter 14. Treatment of Blades.....	249
Chapter 15. Treatment of Impellers.....	282

	Chapter 16. Treatment of Housing Parts and Subassemblies of the Turbopump Unit.....	293
... iii	PART IV. Manufacture of Parts of Automatic Equipment...	307
... iv	Chapter 17. Manufacture of Parts of Automatic Equipment.....	308
... vii	PART V. Assembly of Rocket Engines and Their Subassembly.....	321
... ix	Chapter 18. Development of Technological Processes of Assembly.....	322
... 1	Chapter 19. Equipment of Assembly Workshops, Tool and Devices Used in the Assembly.....	334
... 2	Chapter 20. Preparation of Parts for Assembly.....	341
... 6	Chapter 21. Fulfillment of Assembly Connections.....	354
... 32	Chapter 22. Accuracy of Assembly Balancing.....	370
... 46	Chapter 23. Assembly of Subassemblies and Units of Liquid Propellant Rocket Engines.....	378
... 55	Chapter 24. General Assembly of Liquid Propellant Rocket Engines.....	390
... 91	Bibliography.....	398
... 122		
... 150		
... 163		
... 164		
... 173		
... 189		
... 201		
... 202		
... 228		
... 249		
... 282		

U. S. BOARD ON GEOGRAPHIC NAMES TRANSLITERATION SYSTEM

Block	Italic	Transliteration	Block	Italic	Transliteration
А а	<i>А а</i>	A, a	Р р	<i>Р р</i>	R, r
В в	<i>В в</i>	B, b	С с	<i>С с</i>	S, s
В в	<i>В в</i>	V, v	Т т	<i>Т т</i>	T, t
Г г	<i>Г г</i>	G, g	У у	<i>У у</i>	U, u
Д д	<i>Д д</i>	D, d	Ф ф	<i>Ф ф</i>	F, f
Е е	<i>Е е</i>	Ye, ye; E, e*	Х х	<i>Х х</i>	Kh, kh
Ж ж	<i>Ж ж</i>	Zh, zh	Ц ц	<i>Ц ц</i>	Ts, ts
З з	<i>З з</i>	Z, z	Ч ч	<i>Ч ч</i>	Ch, ch
И и	<i>И и</i>	I, i	Ш ш	<i>Ш ш</i>	Sh, sh
Я я	<i>Я я</i>	Y, y	Щ щ	<i>Щ щ</i>	Shch, shch
К к	<i>К к</i>	K, k	Ъ ъ	<i>Ъ ъ</i>	"
Л л	<i>Л л</i>	L, l	Ы ы	<i>Ы ы</i>	Y, y
М м	<i>М м</i>	M, m	Ь ь	<i>Ь ь</i>	'
Н н	<i>Н н</i>	N, n	Э э	<i>Э э</i>	E, e
О о	<i>О о</i>	O, o	Ю ю	<i>Ю ю</i>	Yu, yu
П п	<i>П п</i>	P, p	Я я	<i>Я я</i>	Ya, ya

* ye initially, after vowels, and after ъ, ь; e elsewhere.
 When written as ѣ in Russian, transliterate as yѣ or ѣ.
 The use of diacritical marks is preferred, but such marks
 may be omitted when expediency dictates.

FOLLOWING ARE THE CORRESPONDING RUSSIAN AND ENGLISH
 DESIGNATIONS OF THE TRIGONOMETRIC FUNCTIONS

Russian	English
sin	sin
cos	cos
tg	tan
ctg	cot
sec	sec
ccsec	csc
sh	sinh
ch	cosh
th	tanh
cth	coth
sch	sech
cach	csch
arc sin	sin ⁻¹
arc cos	cos ⁻¹
arc tg	tan ⁻¹
arc ctg	cot ⁻¹
arc sec	sec ⁻¹
arc ccsec	csc ⁻¹
arc sh	sinh ⁻¹
arc ch	cosh ⁻¹
arc th	tanh ⁻¹
arc cth	coth ⁻¹
arc sch	sech ⁻¹
arc cach	csch ⁻¹
—	
rot	curl
lg	log

In the book the basic technological processes of the manufacture of the most characteristic parts, subassemblies and units of liquid-propellant rocket engines (ZhRD) are examined: combustion chamber (KS), turbopump unit (TNA), power frames, valves, pipelines, and also the technology of unit and general assembly.

Much attention is given to the manufacture of the combustion chamber. A division of the KS into technological subassemblies is given. Contemporary methods of the obtaining of accurate thin-walled large parts, the technology of their machining and adaptation for the fastening of parts having little rigidity are discussed in detail. Methods of the connection of thin-walled large parts by welding and brazing with the use of high-temperature solders and also of the design of special devices for welding and soldering in inert gases and in a vacuum are examined. Characteristic defects of welding and soldering and methods of their detection are given. Technology of the manufacture of injectors, injector heads and the technology of KS assembly are examined. In examining the technology of manufacture of welded frames one pays attention to methods of obtaining accurate dimensions, taking into account the redistribution of internal stresses.

Methods of the manufacture of thin-walled pipelines of complex configuration from sheet metal, the technology of the fitting of nipples, formation of corrugations, and methods of the assembly of pipelines are discussed.

In the examining of the technology of manufacture of parts of the turbopump unit, the main attention is turned to the selection of rational billets, to methods of basing of parts during machining to obtain the assigned accuracy, and to the application of contemporary methods of treatment in finishing operations. Methods of the static and dynamic balancing of parts and subassemblies of the turbopump unit are examined.

Methods of assembly, tools and equipment of assembly workshops, methods of preparation of parts for assembly, the applying on of protective coatings, and methods of the fulfillment of assembly connections are examined. Examples of the assembly of valves, pumps, turbopump unit and general assembly of the engine are given.

The book is a training manual for students of middle special educational institutions. It can be useful also for students of higher educational institutions and technological specialists.

There are 175 figures and a Bibliography of 8 names.

PREFACE

This book is a training manual on the technology of production of liquid-propellant rocket engines (ZhRD) for students of middle special educational institutions. The curriculums provide a parallel study of constructions and designing of liquid propellant rocket engines, which, naturally, will facilitate the mastering by the students of both subjects, since they are inter-related.

The study of the technology of production of liquid-propellant rocket engines starts from the section of "Design fundamentals of technological processes," where concepts about industrial and technological processes are given, and basic stages of the development of technological processes, methods of an appraisal of its economy and other general questions of the technology of machine building are discussed. In the same section principles of the selection of billets, methods of the calculation of allowance, accuracy of treatment, quality of the surface, and principles of the basing of parts during treatment are examined.

In the second section are examined "Principles of the designing of attachments" (basic requirements for fittings, elements of fittings, calculation and designing, etc.).

Only after the mastering of these two sections can the students approach the study of the specific character of production of the liquid-propellant rocket engine.

Questions studied in the first and second sections of the program are quite fully dealt with in textbooks for technical schools on the technology of machine building (for example, A. P. Tikhonov and M. A. Zaslavskiy "Technology of Machine Building"). This book will serve as a training manual during the study of subsequent sections of the program, where technological processes of the manufacture of characteristic parts and subassemblies of liquid-propellant rocket engines and also their assembly are examined.

In book basic information the knowledge of which is a necessary basis for subsequent deeper study of subject is discussed.

All remarks and requests both on the substance of the questions discussed and in terms of the method of the account should be directed to: Moscow, K-51, Petrovka, 24, Publishing House "Machine building."

INTRODUCTION

The engine is the most important part of any contemporary rocket. Its basic assignment is to create the thrust necessary for imparting acceleration to the rocket during takeoff, acceleration and maneuvering due to the ejection of some mass. On the rocket several engines can be set, and each of them fulfills definite functions and has an appropriate name: main engine, steering engine, retrorockets and others.

Liquid-propellant rocket engines (ZhRD) eject at high speed hot gases - products of combustion of liquid components.

At present different designs of the liquid-propellant rocket engine are mass produced or are in the stage of designing and experimental check. Every design is characterized by peculiarities of the arrangement of the subassemblies and units, the interconnection of the units, their fastening, etc.

Consideration of designs of specific engines is not included in our problem. For training purposes all engines can be conditionally divided into three generalized design schemes.

1. Engine of frame construction, the scheme of which is depicted on Fig. 1. All units on the diagram are shown in simplified form so that it is more distinct to represent the division of the engine into technological subassemblies or groups. The fuel and

oxidizer through pipelines 1 enter into the turbopump unit 2 and then under high pressure are fed along pipelines 3 through control valves 4 and 5 into the combustion chamber (KS) 6. One of components, for example, the oxidizer, proceeds after valve 4 directly into the head of KS, and the other component, for example, the fuel, proceeds through pipelines 7 into the collector 8 of nozzle 9 and, passing along interjacket space into the head of KS, cools its wall.

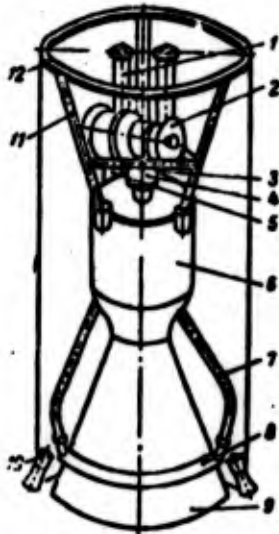

Fig. 1. Schematic diagram of a liquid-propellant rocket engine. 1 - pipelines of fuel and oxidizer; 2 - turbopump unit; 3 - pipeline; 4, 5 - control valves; 6 - combustion chamber; 7 - fuel pipeline; 8 - collector; 9 - nozzle; 10 - control KS; 11 - frame; 12 - joint ring.

The majority of units of the engine is secured to frame 11, which with a joint ring 12 are fastened to the body of the rocket. The combustion chamber is united with the frame securely, and control of the thrust vector is carried out by control combustion chambers 10.

2. Multichamber engines in the form of a cluster of two, four, eight and more KS are used in propulsion systems of large rockets, since one chamber is not able to create the required thrust.

For example, the propulsion system of the first stage of the S-1 American rocket "Saturn" 1 consists of eight liquid-propellant rocket engines. Diagram of the location of the combustion chambers is shown on Fig. 2. Four KS in the center of the installation are secured stationarily to the frame. The other four KS, located

criss-cross along the periphery, have gimbal thrust pads and can be deflected by angle $\pm 7.5^\circ$ in two mutually perpendicular directions. This ensures control of the thrust vector of the installation, i.e., flight control of the rocket without the application of control KS.



Fig. 2. Diagram of the location of the KS in the propulsion system of the first stage of the rocket "Saturn" 1. a) fixed KS; b) Tilting KS.

3. Single-chamber liquid-propellant rocket engine without a power frame. The connecting link of the engine is a combustion chamber on which all units of the engine are braced. Figure 3 shows a simplified diagram of such an engine.

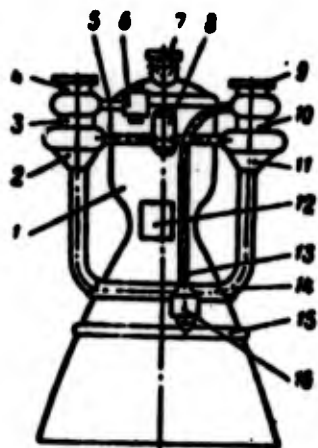

Fig. 3. Diagram of a liquid-propellant rocket engine of frameless design. 1 - combustion chamber; 2 - exhaust collector; 3 - turbopump oxidizer unit; 4 - pipe oxidizer feed; 5 - main line of the oxidizer; 6 - main oxygen valve; 7 - spherical support; 8 - gas generator; 9 - fuel feed; 10 - turbopump unit of fuel; 11 - exhaust collector; 12 - power supply unit; 13 - main fuel line; 14 - exhaust collector; 15 - fuel collector; 16 - main fuel valve.

On each side of the combustion chamber 1 two turbopump units (TNA) are located: oxidizer 3 and fuel 10 with delivery pipelines 4 and 9. The oxidizer from the turbopump unit is fed along the pipeline and through the main valve 6 into the head of the KS, and

the fuel - along pipeline 13 and through the main valve 16 into the collector ring 15. Exhaust gases from turbines are guided through collectors of the turbopump units 2 and 11 and ring header of the chamber 14 into the nozzle part of the KS. In the center of the injector head from above the spherical support 7 is mounted for deflection of the axis of the KS for the purpose of control of the thrust vector. The remaining small units and pipelines are not shown. The advantage of such a configuration is in the fact that a decrease in weight is attained due to the elimination of the frame, the assembly of the engine is simplified and the length of the pipelines decreases.

For an examination of the given configurations it is clear that every liquid-propellant rocket engine has the following basic elements:

1. Combustion chamber (KS), where a chemical reaction (combustion) of fuel components - fuel and oxidizer, occurs.

2. A device for the ordering of flow of gases emanating from the KS and giving the flow an assigned direction (direction of the thrust vector). Usually this is a nozzle directly connected with the KS.

3. Supply system of components (fuel and oxidizer) from the fuel tanks into the combustion chamber. Most frequently in engines of great thrusts for these purposes a turbopump unit (TNA) is used. There exist also feed systems of components by means of displacing them from tanks by compressed gas.

4. Gas generator (GG) for the output of gas which serves as the working substance for rotation of the turbine of the turbopump unit or for other purposes. With nonpump feed of components the gas generator can serve as a source of displacing gas.

5. A system of pipelines for the connection of the fuel tanks with the turbopump unit and exhaust ducts of pumps with automatic units, GG and combustion chamber.

6. Control valves and actuators.

7. System of capacities and pipelines for feeding by liquid, air or inert gas of actuating valves and controlling mechanisms. The most widespread at present is the electrical system.

8. Devices for the connection of all units and transmission of thrust of the engine to the body of the rocket. This can be a power frame or rigid combustion chamber to which the units are mounted.

9. Thrust vector control system in the form of devices for deflection of the axis of the nozzle of the KS, special control combustion chambers, and control nozzles fed by the exhaust of the turbopump assembly or gas into the nozzle of the KS.

10. Electrical systems.

A program of instruction and this book provide the study of principles of the technology of manufacture of characteristic parts, subassemblies and units of a liquid-propellant rocket engine and their assembly. The book consists of the following sections:

I. Manufacture of combustion chambers.

II. Manufacture of frames and pipelines.

III. Manufacture of basic parts of turbopump units.

IV. Manufacture of parts of automatic control.

V. Assembly of engines and their subassemblies.

The basic requirement in the production of a liquid-fuel rocket engine is the absolute reliability of units and articles having high technical characteristics with minimum weight and volume. The

latter is attained by the application of high pressures, high temperatures and high numbers of revolutions. For the manufacture of such units, it is required to use highly durable and heat-resistant materials and thin-walled constructions.

The connection of the parts must be fulfilled by the most accomplished technological processes so that the strength of the connection is not lower than the strength of the basic material.

Special attention is given to the finishing of surfaces of the parts and accuracy of the dimensions.

All of this is attained by the high degree of production and clear observance of industrial and technological discipline.

P A R T I

MANUFACTURE OF COMBUSTION CHAMBERS

FTD-MT-24-39-70

C H A P T E R 1

DESIGN CONFIGURATIONS OF COMBUSTION CHAMBERS AND THE DIVISION INTO TECHNOLOGICAL SUBASSEMBLIES

The combustion chamber (KS) is the most important unit of the liquid-propellant rocket engine operating in very difficult conditions. The combustion of fuel occurs in a small volume with high heat stresses and high pressure. For the purpose of increasing the burning rate the proceeding liquid components should be very finely atomized and evenly mixed. Atomization is carried out by the injector head (FG), the good operation of which is governed by the effectiveness of the operation of the KS. The mixing of gaseous components is carried out by the mixing head.

Internal walls of the combustion chamber are washed by gases the temperature of which considerably exceeds the melting point of the material of wall. Therefore, the walls should be intensively cooled. Furthermore, walls of the KS undergo high pressure of the gases. Since the weight of combustion chamber should be a minimum, it is made from highly durable thin-sheet materials.

The combustion chamber (Fig. 1.1) consists of the following basic technological subassemblies: injector head or mixing head (SG); central part; cooled nozzle part; uncooled nozzle part - orifice.

These subassemblies of the KS are connected by welding or with the help of bolts. The central part and nozzle cooled part are frequently made as one.

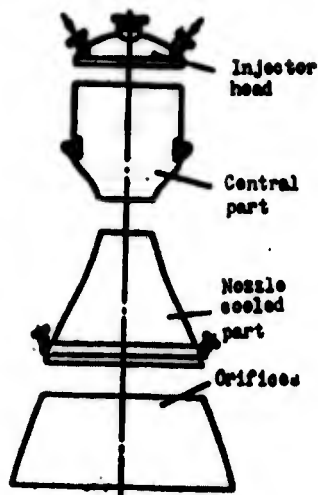

Fig. 1.1. Division of the KS into technological subassemblies.

The injector head is schematically depicted on Fig. 1.2. It consists of a fire base 1, middle base 2, upper base 3, spherical support 4, nozzles of oxidizer feed 5, collector of fuel feed 6, oxidizer injectors 8, and fuel injectors 7. The quantity of the injectors is determined by the dimension of the KS and requirements for the spray of the components.

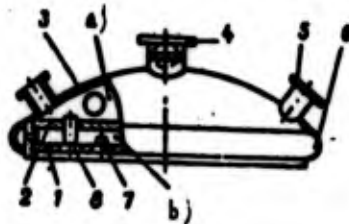

Fig. 1.2. Diagram of an injector head. a) oxidizer cavity; b) fuel cavity. 1 - fire base; 2 - middle base; 3 - upper base; 4 - spherical support; 5 - nozzle; 6 - collector; 7 - fuel injector; 8 - oxidizer injector.

Instead of a central spherical support 4 certain combustion chambers have special journals welded to the jacket of the central part of the KS approximately at the center of gravity (for example, the chamber of the liquid-propellant rocket engine "Gamma" for the rocket "Black Knight").

The subassembly - central part and cooled part of the nozzle of the KS - is schematically depicted on Fig. 1.3. It consists of an internal (fire) shell or wall 1, outer shell or jacket 2, journals 3, collector 4, branch pipes with flanges 5.

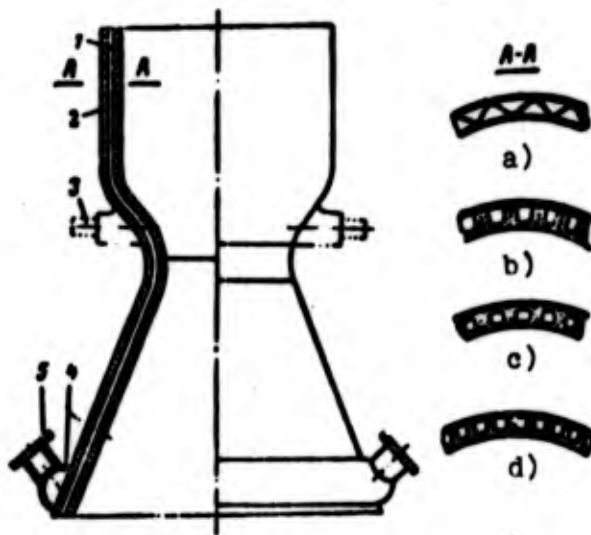

Fig. 1.3. Construction of the central part of the KS. 1 - wall; 2 - jacket; 3 - journal; 4 - collector; 5 - branch pipe with flange.

The wall 1 comes into contact with the gases at high temperature and should be intensely cooled. For this purpose along channels of the interjacket space a liquid coolant, one of the components of the fuel, most frequently the propellant, flows.

Channels for the liquid can be formed by several methods:

a) the installation of corrugated adapters between the jacket and the wall (Fig. 1.3a);

b) the connection by soldering of Π -shaped profiles with a subsequent annular groove along the surface of adjoining of the jacket (Fig. 1.3b);

c) the connection by soldering of profiled tubes (Fig. 1.3c);

d) milling, etching or pressing of longitudinal channels in the wall (Fig. 1.3d).

The most widespread in practice of firms of the United States, England and France has been the method of manufacture of walls from profiled steel or aluminum tubes (see Fig. 1.3c), although the method shown on Fig. 1.3b is used.

Jacket 2 is made of highly durable materials - steel and titanium. It can be made solid all over the contour of the wall or in the form of separate rings, which is determined by the calculation for strength of the KS under the condition of minimum weight of the construction. In certain designs the jacket is made by the winding of a steel tape or wire with subsequent soldering. Jackets of fiberglass, impregnated plastic are used also.

Journals 3 absorb the thrust of chamber and are welded to the reinforced part of the jacket of the KS. In order to avoid great deformations of flexible lines with revolutions of the rocking the KS, the fuel and oxidizer can be fed through axial drillings in the journals.

Collector 4 serves for equal distribution of the liquid coolant along channels of the wall of the KS. It is made of sheet metal and welded or is soldered to the jacket of the KS. The liquid is set into one, two or more nozzles with welded flanges 5 for the connection to pipelines proceeding from the turbopump unit.

The uncooled part of the nozzle undergoes comparatively low internal pressure and is made of thin-sheet material (steel, titanium); it is fastened to the central part of the KS by welding or bolts. For protection from high temperature different coverings applied by electrodeposition, plasma atomization, diffusion and other methods are used.

CHAPTER 2

METHODS OF OBTAINING THIN-WALLED BILLETS OF PARTS OF COMBUSTION CHAMBERS.

§ 1. Cut of the Metal

Steel, titanium and other materials for basic parts of the KS come to the plant in the form of sheets of the needed thickness and standard dimensions. From the sheets billets will be cut. The configuration of the billet is determined by the method of scanning of surfaces. Let us explain this using the simplest examples.

1. It is required to determine the dimension of billet for the cylindrical ring of the jacket of the KS. The internal diameter $D_{BH} = 350$ mm; height $H = 200$ mm, thickness of material $\delta = 6$ mm. The machining allowance on surfacing after welding $z = 3$ mm from each end.

Solution. Length of the billet (scanning along the average diameter)

$$L = \pi D_{cp} = 3,14 \cdot 356 = 1118 \text{ mm,}$$

where $D_{cp} = D_{BH} + \delta$.

$$\text{Width } B = H + 2z = 200 + 2 \cdot 3 = 206 \text{ mm.}$$

2. It is required to determine the dimension of the billet for the uncooled orifice of the nozzle having the form of a frustum

of a cone: the biggest diameter D_1 , least diameter D_2 , height H .

To determine the scanning, we draw the orifices to full-scale, as is shown on Fig. 2.1.

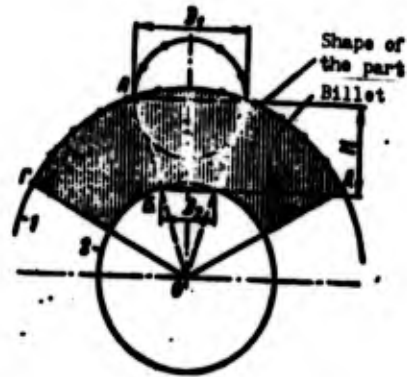

Fig. 2.1. Scanning of the frustum of a cone.

Continuing the lateral generatrices of the cone, we find point O . From this point by radii OZ and OB we draw circumferences 1 and 2. On circumference 1 we plot arc ΓA equal to the length of the circumference by diameter D_1 . Points Γ and A unite with center O . The shaded area will be the scanning of the frustum of the cone.

Equipment for the cutting of billet is selected depending upon the configuration of the billet and thickness of the sheet.

Cuts along the circumference or along arcs of the circumference are made on roller shears. More complex cuts are made on vibration shears.

With a large quantity of parts for cutting of billets are used cutting stamps. A typical design of a cutting stamp is depicted on Fig. 2.2.

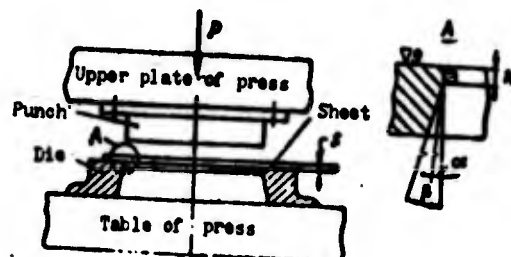

Fig. 2.2. Diagram of a cutting stamp.

The die of the stamp is secured on the table of the press and the punch - on the upper plate of the press. The force of the press is determined by the force of cutting

$$P = 1.25 L s \tau_{cp} K \text{ hN,}^1$$

where L - perimeter of the cut contour in cm; s - thickness of metal in cm; K - coefficient considering magnitude of the angle of bevel of the cutting edges (K = 0.4-0.6); 1.25 - safety factor; τ_{cp} - tensile strength of the material with the section in MN/m^2 .

The least force of the section and best cleanness is attained at definite angles of sharpening of the die and optimum clearance between the cutting edge of the die and punch. Recommended values of leap angles and clearances are given in Table 2.1 and 2.2.

Table 2.1.

Thickness of the sheet s, mm	Leap angles	Die	A mm
	α°	β°	
Up to 1	10'—30'	2°—3°	3—5
From 1 to 6	30'—1°	3°—5°	5—10
From 6 to 12	1°—1°30'	3°—5°	10—15

Table 2.2.

Thickness of the material s, mm	Clearances between punch and die in mm	
	Soft steel, stainless steel, copper, brass	Steel of average hardness, Duralumin
1—2	0.06	0.07
2—3	0.07	0.08
3—5	0.08	0.09
5—8	0.09	0.1
8—16	0.1	0.11

More detailed recommendations on the selection of clearances are given in the special reference literature.

A diagram of cutting by roller shears is shown on Fig. 2.3a. With the fastening by center O, it is possible to cut the billets without marking in form of a circle or sector of a circle. Billets of more complex form will be cut with preliminary marking on the pattern. With great thickness of the material and small radii of the contour of the billet, vibration shears (Fig. 2.3b) or an oxyacetylene torch are used.

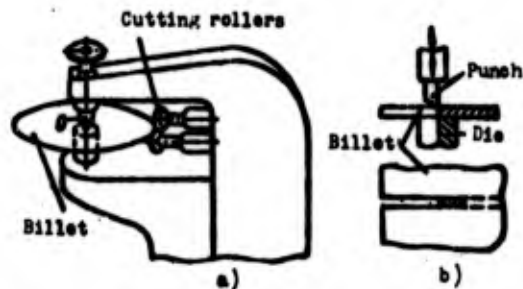

Fig. 2.3. Diagram of the cutting of sheet metal. a) roller shears; b) vibration shears.

The selection of a certain method of the cut depends on technological possibilities of concrete production, dimensions, form and thickness of the billet, and also quality of the material. If the billet can be obtained by two or three methods, then the question of the selection of the variant is decided by comparative economic calculations.

The cost (workshop) C of the manufacture of an assigned group of parts is determined by the equation

$$C = Px + K,$$

where P -- current expenditures for the manufacture of one part;
x -- quantity of parts in the group; K -- expenditures for the manufacture and adjustment of special attachments and tools.

Current expenditures are composed of four elements:

$$P = M + \text{З} + A + \text{Э}$$

where M - cost of the material; З - basic wage; A - expenditures for depreciation of the equipment; Э - operational expenditures.

For comparison two or more possible variants of the technology of manufacture of a part are taken, and after determination of the cost of manufacture of the group of parts with respect to every variant the most economic variant is selected.

Example. The billet depicted on Fig. 2.4a can be obtained cutting in a stamp or cutting by the marking on vibration shears. It is required to determine with what group of parts profitably to prepare the cutting stamp.

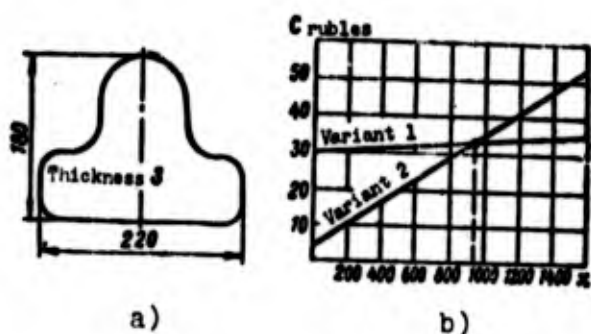

Fig. 2.4. Comparison of variants of cutting of the billet.

Solution.

Variant 1: manufacture in the die.

Force of cutting

$$P = 1,25Lsr_{cp}K = 1,25 \cdot 66 \cdot 0,3 \cdot 430 \cdot 0,5 = 5300 \text{ hN (53 t)}.$$

Cutting can be produced on a press developing a force of 75 t.

The rates for the depreciation of the press - 0.03 kopecks/min.³

Operational rates - 0.01 kopecks/min.³

Cost of the stamp (according to data of the workshop of equipment) - 30 rubles.

Piece time for the cutting of the billet - 0.4 minutes.

Class of work - 3rd. Rate per hour $\Phi = 41.3$ kopecks.

Wages

$$3 = \frac{\Phi t_{\text{шт}}}{60} = \frac{41.3 \cdot 0.4}{60} = 0.274 \text{ kopecks.}$$

Variant 2: cutting by marking on vibration shears.

Rates for depreciation of shears - 0.02 kopecks/min.⁴

Operational expenditures - 0.007 kopecks/min.⁴

Cost of the pattern for marking - 5 rubles.

Piece time:

for marking - 0.20 minutes,

for cutting - 4 minutes.

Class of work - 3rd.

Wages

$$\frac{\Phi t_{\text{шт}}}{60} = \frac{41.3 \cdot 4.2}{60} = 2.9 \text{ kopecks.}$$

Data of the calculations are given in the table (cost of the material is identical in both variants and, consequently, in a comparative calculation can be excluded).

From these data let us construct the graph (Fig. 2.4b).

From the graph it is clear that lines of costs cross approximately at 900 parts. This shows that with this group the variants are economically equivalent.

Table 2.3.

Designation of expenditures	Variant 1 Cutting in stamp	Variant 2 Cutting on vibration shears
Current expenditure P in kopecks:		
wages	0.274	2.9
expenditure for depreciation	$0.03 \cdot 0.4 = 0.012$	$0.02 \cdot 4.4 = 0.084$
operational expenditure	$0.01 \cdot 0.4 = 0.004$	$0.007 \cdot 4.2 = 0.0294$
Total in kopecks	0.29	3.0134
Simultaneous expenditures K in rubles	30	5
Cost C in rubles:		
with $x = 0$	30	5
with $x = 2000$	$\frac{0.29 \cdot 2000}{100} + 30 =$ = 35.8	$\frac{3.01 \cdot 2000}{100} + 5 =$ = 65.2

If in a group there are more than 900 parts it is economically profitable to prepare a cutting stamp. If in a group there are less than 900 parts it is economically expedient to conduct cutting by marking.

§ 2. Bending of Parts

Bending of sheet bars is carried out in stamps under press or on special bending machines. The simplest method of the formation of cylindrical and conical parts is by bending on rolling machines. A diagram of bending is shown on Fig. 2.5a. A deficiency of this method is the low accuracy of the required radius of bending and the impossibility of the bending of the sheet near the edge at the beginning and end of the bending. Therefore, parts obtained by rolling must be finished on mandrels.

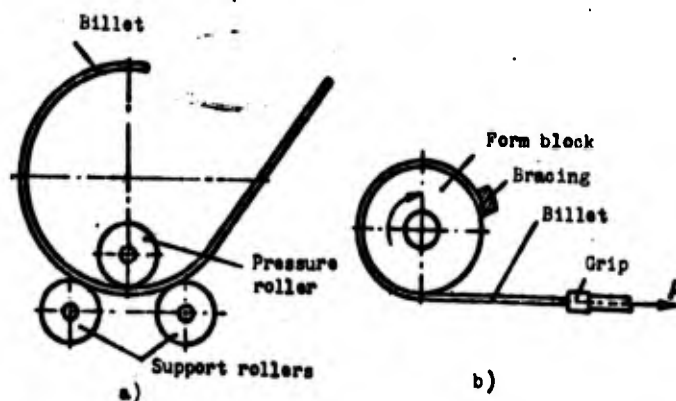

Fig. 2.5. Diagrams of the bending of sheet material.

Higher accuracy is given by the method of bending on a form block with an extension, as was shown on Fig. 2.5b. The billet by one end is secured on the form block and by the other in a high-speed grip connected with a rod of a hydrocylinder. As a result of the pressure of oil in the hydrocylinder the billet is stretched and in a stretched state is reeled on the revolving form block. In the process of winding the tensile force is maintained constant. The magnitude of the tensile force is determined by experimental means. Usually force (P) creates a stress in the material of the billet somewhat exceeding the yield point

$$P = \sigma_y F,$$

where σ_y - yield point of the material of the billet; F - area of cross section of the billet.

Billets subjected to such a process of bending must have all along the length an equal area of cross section, i.e., must not have steps and cuts, otherwise in weakened places there will appear very great stresses, which will lead to impermissible thinning of the metal or a break.

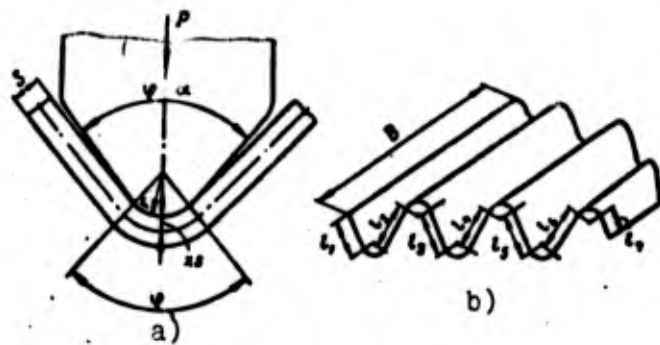

Fig. 2.6. Determination of edge angle of the punch and length of the billet.

With bending in stamps with small radii of the bend, one should consider the stress appearing in the material of the billet. With the bend of metal internal layers are compressed and external - stretched (Fig. 2.6a).

To avoid a break of external fibers, the minimum radius of bending r is determined depending upon the thickness of the material

$$r = k_s s,$$

where k_s - coefficient dependent on the material of the billet and angle of bending ϕ is selected from tables in reference books.

With the bending neutral axis of the billet at the place of bending is displaced in the direction of the compressed region of metal, which one should consider in the determination of the length of the billet.

With the complex configuration of the bent part the length of the billet is determined by the formula

$$L = \sum l_i + \sum \varphi_i R_i$$

where $\sum l_i$ - sum of lengths of rectilinear sections l_1, l_2, l_3, \dots (Fig. 2.6b); $\sum \varphi_i R_i$ - sum of lengths of the curvilinear sections; φ_i - angle in radians; $R_i = r_i + xs$ - radius up to the neutral axis; x - coefficient of displacement of the neutral axis selected from tables. With $r/s > 10$ $x = 0.5$.

The force of bending is determined by formulas:
with bending without clamp of the edges

$$P_1 = 1.25 K_{H3} B s \sigma_B h N,$$

where 1.25 - safety factor; B - length of the line of bend in cm (see Fig. 2.6b); s - thickness of material in cm; σ_B - tensile strength in MN/m^2 ; K_{H3} - coefficient selected from tables.

Certain values of it are given below:

r/s	0.5	1	2	3	4	5	10
K_{H3}	0.4	0.3	0.2	0.16	0.12	0.1	0.06

With bending with a clamp of edges of the billet

$$P = P_1 + Q,$$

where Q - force of the clamp.

Usually $Q = (0.25-0.3) P_1$ is taken.

In the designing of stamps one should consider that the angle ϕ of the part is larger than the edge angle of the punch due to the straightening of the part after bending due to a spring. Therefore, the angle of sharpening of the punch should be equal to $\phi - \alpha$ (see Fig. 2.6a), where α - angle of the spring determined by experimental means or from reference books.

By the method of bending in stamps with small radii corrugated separators are prepared [5]. In a stamp there are usually four grooves in accordance with the profile of the corrugation. For every working stroke the stamped part moves on one groove.

§ 3. The Drawing of Parts

The basic parts of the KS constitute a solid of revolution. The drawing of such bodies can be produced from flat billings in the form of a circle with diameter $D_{\text{бар}}$. The drawing can be without thinning and with thinning of the sheet of the billet. In drawing without thinning the diameter of the billet is calculated proceeding from equality of surfaces of the billet and stamped part taking into account the allowance for the cutting of edges after the drawing. To determine surfaces of parts of the complex geometric forms, they are divided into elements of simple geometric forms - cylinders, frustum of a cone - and their surface is determined by known formulas.

The diameter of the billet is determined by formula

$$D_{\text{бар}} = \sqrt{\frac{4}{\pi}(F_1 + F_2 + F_3 + \dots + F_n)}$$

where F_1, F_2, F_3, \dots - surfaces of simple bodies on which a division of the complex part is performed.

Example. Calculate the diameter of the billet for drawing of the jacket of the KS depicted on Fig. 2.7.

Solution. We trace the contour of stamping in the scale 1:1 with allowances for cutting after stamping (Fig. 2.7b). We divide the surface of the part into surface elements: cylinders F_1, F_3, F_4, F_6 , cone F_2 and circle F_5 . We find the area of these surfaces (digital quantities h and l are measured from the drawing):

$$F_1 = \pi D h_1 = 3,14 \cdot 30 \cdot 26 = 2450 \text{ c.m.}^2.$$

$$F_2 = \frac{\pi l}{2} (D + d) = \frac{3,14 \cdot 9}{2} (30 + 15) = 636 \text{ c.m.}^2.$$

$$F_3 = \pi D h_3 = 3,14 \cdot 15 \cdot 4 = 188 \text{ c.m.}^2.$$

$$F_4 = \pi d h_4 = 3,14 \cdot 15 \cdot 1 = 47 \text{ c.m.}^2.$$

$$F_5 = \frac{\pi d^2}{4} = \frac{3,14 \cdot 15^2}{4} = 177 \text{ c.m.}^2.$$

$$F_6 = \pi D h_6 = 3,14 \cdot 30 \cdot 1 = 94 \text{ c.m.}^2.$$

$$\underline{\Sigma F = 3592 \text{ c.m.}^2.}$$

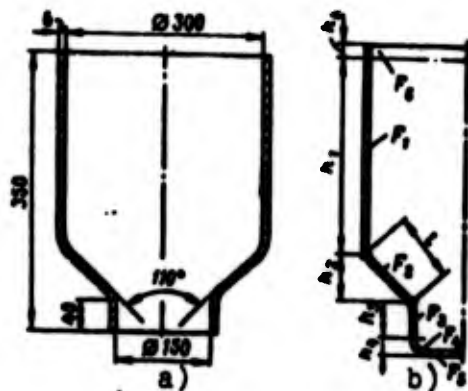

Fig. 2.7. Division of complex form into surface elements.

The diameter of the billet

$$D_{\text{billet}} = \sqrt{\frac{4}{\pi} \cdot 3592} = 67,7 \text{ c.m.}$$

With deep drawing of parts from the sheet considerable deformations and cold hardening of the metal occur. The magnitude of the drawing has a definite limiting higher than which a break of the metal occurs. Therefore, parts of deep drawing are stamped in several transitions with intermediate annealings of the billet for the removal of residual stresses. The relationship of diameters of the billet and drawing is determined by the elongation coefficient m established experimentally.

For the most characteristic cases elongation coefficients are given in reference books. By knowing the permissible elongation coefficients, one can determine the necessary quantity of transitions and intermediate dimensions of the billets.

Example. Determine the quantity of transitions and intermediate dimensions of the billets for the stamping of the part depicted on Fig. 2.7.

Solution (elongation coefficients are taken from a reference book on cold forging).

$$\text{I transition } D_1 = D_0 m_1 = 677 \cdot 0.59 = 399 \text{ mm};$$

$$\text{II transition } D_2 = D_1 m_2 = 399 \cdot 0.75 = 300 \text{ mm};$$

$$\text{III transition } D_3 = D_2 m_3 = 300 \cdot 0.8 = 240 \text{ mm};$$

$$\text{IV transition } D_4 = D_3 m_4 = 240 \cdot 0.82 = 197 \text{ mm};$$

$$\text{V transition } D_5 = D_4 m_5 = 197 \cdot 0.85 = 167 \text{ mm};$$

$$\text{VI transition } D_6 = D_5 m_6 = 167 \cdot 0.9 = 150 \text{ mm}.$$

The height of the intermediate stampings is determined from the condition of equality of the areas (Figs. 2.7 and 2.8):

$$\text{Transition I } h_1 = \frac{3592 - \frac{3,14 \cdot 399^2}{4}}{3,14 \cdot 399} = 187 \text{ mm};$$

$$\text{Transition II } h_2 = \frac{3592 - \frac{3,14 \cdot 300^2}{4}}{3,14 \cdot 300} = 306 \text{ mm};$$

$$\text{Transition III } h_3 = \sqrt{70^2 - \left(\frac{300 - 240}{2}\right)^2} = 63 \text{ mm};$$

$$\text{Transition IV } h_4 = \sqrt{90^2 - \left(\frac{300 - 197}{2}\right)^2} = 80 \text{ mm};$$

$$\text{Transition V } h_5 = \sqrt{90^2 - \left(\frac{300 - 167}{2}\right)^2} = 73 \text{ mm}.$$

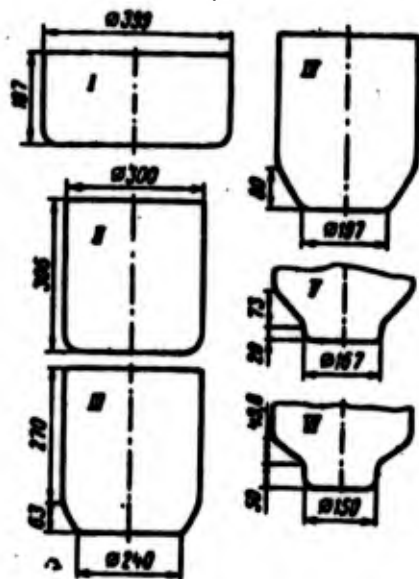

Fig. 2.8. Technological transitions with deep drawing.

The form and dimensions of the intermediate drawings are depicted on Fig. 2.8. From these dimensions stamps are designed. Figure 2.9 shows the design of a stamp for the first transition. The punch 4 passes through clamp 3 and is fastened to the upper plate of the press. The form of the punch is made according to the form of the internal surface of the stamping. Cavity A serves for the easing and hole d for the passage of air into the cavity between the punch and stamping with yield of stamping from the punch. Clearances between the punch and die and radii of curvatures of working edges of the die are taken from reference books.

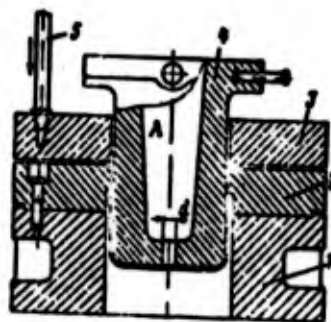

Fig. 2.9. Design of a draw stamp. 1 - support; 2 - die; 3 - clamp; 4 - punch; 5 - clamp rod.

The press for drawing will be selected according to the force of drawing determined by formula

$$P_1 = \pi D_n s \sigma_s K_n h N$$

where D_n - diameter of drawing in cm; s - thickness of the material in cm; K_g - coefficient dependant on the relationship of diameters of drawing of the billet.

D_n/D_g	0,55	0,575	0,6	0,65	0,7	0,75	0,8
K_g	1,0	0,93	0,86	0,72	0,6	0,5	0,4

If drawing is conducted with a clamp, then the force of drawing

$$P = P_1 + Q.$$

where Q - force of the clamp determined by calculation or by experimental means.

The process of drawing in stamps is accompanied by slip of the sheet with respect to the die and clamp, which causes considerable frictional forces, nadsirs on the part and rapid wear of the stamp. For the purpose of decreasing forces of friction and the protection of surfaces of the part and stamp from abrasion, through finishing of surfaces of the stamp touching the sheet (working planes of the die and clamp, curvatures of the die) is fulfilled, and the billet is lubricated with a mixture of oil with graphite, or it is preliminarily covered by a thin layer of varnish, dried, and then lubricated with oil.

In the process of annealing of the billet between the transitions the layer of oil and varnish burns, and on the surface a film of oxides appears. Therefore, after heat treatment the billet is subjected to etching, washing and drying, after which again the layer of varnish and oil is applied on it.

The accuracy of dimensions of parts obtained by stamping is low and depends on the thickness of the sheet and diameter of the stamping. For example, with a thickness of the wall at 1.5 mm

and diameter of the stamping of 100-300 mm, the error of the diameter of the stamping is ± 0.6 mm.

Furthermore, after heat treatment local deformations (warping) appear. To increase the accuracy of the stamping, calibration is used on mandrels or in a calibration stamp with small deformations of the metal of the part. To obtain billets of parts of type of the jacket or a wall of a KS, a set of 6-9 stamps is required. The manufacture of such a set of stamps is associated with great expenditures of means and time and is not always expedient. In certain cases it is economically more profitable to use other methods of the molding of thin-walled parts.

§ 4. Stamping by Liquid

The formalization of parts by means of the pressure of liquid consists in the fact that one of the elements of the stamp - the die or punch - is replaced by liquid. Figure 2.10 shows a diagram of molding in a die.

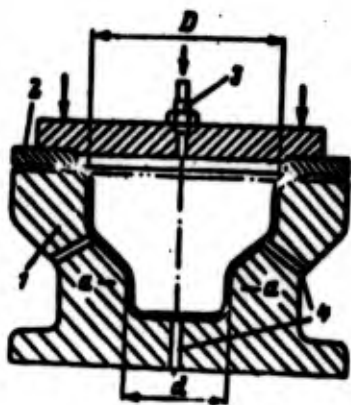

Fig. 2.10. Diagram of hydromolding. 1 - die; 2 - clamp; 3 - pipe connection for liquid feed; 4 - drain holes.

The sheet bar is pressed between die 1 and clamp 2, and through the pipe connection 3 liquid under pressure is fed. Under the action of this pressure the billet starts to be sagged and fill the cavity of the die, displacing the air through drain holes 4.

Pressure of the liquid acts evenly in all directions, in consequence of which the sheet is tightly pressed to surfaces of deepening in the die, forming the needed form of the part. With this deformations of the metal under the impact of uniform pressure of liquid are more favorable than with the drawing by a rigid punch. Therefore, in one transition without intermediate annealing with molding by liquid, a deeper drawing than in the usual stamp can be obtained. The accuracy of stamping by this method is higher. The pressure of the liquid is determined from the condition of the creation in the metal of the billet of stresses slightly exceeding the yield point. In the stamp depicted on Fig. 2.10, the most unfavorable place of drawing will be section a-a with respect to diameter d.

For the deformation of metal in section a-a in the direction of the axis of symmetry, it is required that the axial force from the pressure of the liquid

$$P = p \frac{\pi d^2}{4}$$

cause a stress in the metal of the billet

$$\sigma = \frac{P}{\pi d s}$$

not less than the yield point.

Consequently, it is possible to write the equality

$$p \frac{\pi d^2}{4} = \sigma_y \pi d s,$$

or, after transformations

$$p = 4 \frac{s}{d} \sigma_y,$$

where p - required pressure of the liquid.

Hence it is clear that the pressure of the liquid depends on mechanical properties of the material of the billets and on the ratio of the thickness of the metal s to the least diameter of the stamped part. At the contemporary level of the technology of molding by liquid satisfactory results are obtained with the relation $s/d < 0.01$, i.e., thin-walled parts are stamped well.

§ 5. Explosive Forming

A diagram of explosive forming is given on Fig. 2.11a.

The sheet bar 1 is placed between the die 2 and upper force cover 3. A charge of explosive 4 is set in the upper part of the cavity of cover 3; at the same place there is an igniter 5. The closing of the cover and die is produced by a crosspiece 6 of the force block 7. The explosion creates high pressure in cavity A, and under the impact of this pressure rapid molding of the billet according to the form of the recess in the die occurs. Air departs through the drain hole 5. Figure 2.11b shows a diagram of stamping by a blast wave. In the upper cover there is a spheric groove for amplification of the action of the blast wave. The method of molding with pressure propagation of the explosion on the billet through liquid is also used, which leads to a more equal distribution of pressure on the billet and decreases the force of the sound effect.

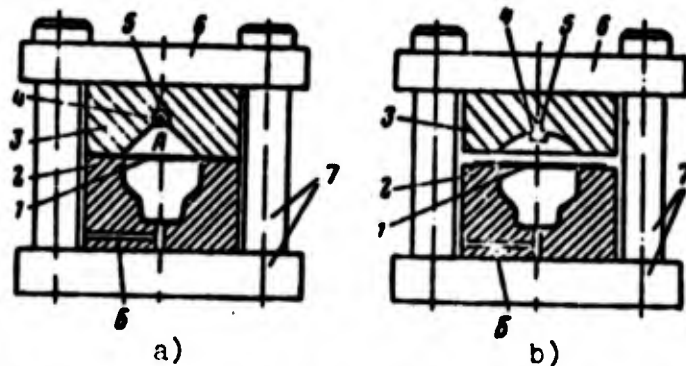

Fig. 2.11. Diagram of explosive molding.
 1 -- billet; 2 -- die; 3 -- force cover;
 4 -- explosive; 5 -- igniter; 6 -- cross-
 piece; 7 -- force block.

Explosive forming is a simple method not requiring expensive presses. Deficiencies consist in the undesirable sound effect and danger in accidental unforeseen explosions with careless handling. Due to these deficiencies in installation for explosive forming, it is necessary to assemble in separate locations equipped in accordance with requirements of safety engineering.

§ 6. Potary Rolling or Extrusion

The essence of this method is shown on Fig. 2.12.

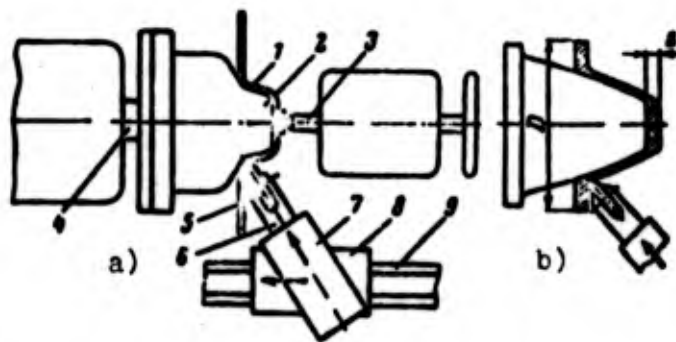

Fig. 2.12. Diagram of the pressing of thin-walled parts. 1 - billet; 2 - mandrel; 3 - clamp; 4 - spindle of the machine; 5 - molding roller; 6 - holder; 7 - hydrocylinder; 8 - carriage; 9 - guides of the machine.

The sheet bar 1 is set on the face of the mandrel 2 and is pressed down by the center 3. The mandrel 2 together with the billet is rotated from the spindle 4 of the machine. The roller 5, secured on the holder 6 of the hydrocylinder 7, presses on the metal and simultaneously moves together with the hydrocylinder and carriage 8 along guides 9 in the direction of the feed - on the figure from right to left. The roller is rolled on the billet, and the material of the billet is deformed and densely tight to the surface of the mandrel. With the complex configuration of the part the pressure on roller and feed must be changed in accordance with the assigned contour. In this case program control of the machine is used.

The force of pressure of the roller on the metal of the billet depends on mechanical properties of the metal and thickness of the sheet. Under the action of this force in the metal of the billet under the roller a stress exceeding the yield point should be created. The thickness of the sheet with such pressing is practically not changed.

If one were to increase the pressure of the roller on the metal and create stress in the metal of $2000-3000 \text{ MN/m}^2$ (200-300 kgf), then considerable thinning of the procurement will occur. A diagram of pressing with thinning of the thickness of the sheet of the billet is shown on Fig. 2.12b. The diameter of the billet D is taken equal to the diameter of the flange of the part, and the thickness s of the metal is determined from the condition of equality of volumes of the part and billet.

With the pressing of parts with thinning the external diameter of the billet remains constant, and the thickness of the extruded part s is changed in proportion to the sine of angle of the mandrel

$$s_1 = s_0 \sin \alpha.$$

By this method parts of conical, spheric, convex and other forms, with the exception of cylindrical can be obtained.

The number of turns of the ingot with the billet is determined proceeding from the optimum relative speed of rolling of the roller. This speed is within 150-600 m/min depending upon properties of the metal.

With deep drawing the metal of the billet is work hardened, and in it cracks or breaks can appear. Therefore, parts of deep drawing are prepared after several transitions with intermediate annealing as well as with stamping. However, the quantity of transitions with extrusion is less, and the accuracy is higher than that with stamping.

Extrusion is conducted on special machines or re-equipped lathes and turret lathes. For re-equipment under press works usually machines intended for rough stripping operations possessing great rigidity for absorbing forces of the roller are selected. The low accuracy of these machines does not affect the accuracy of the extrusion, since the form and accuracy of the part is determined by the mandrel, taking into account the magnitude of exfoliation of the part from the mandrel. The machine tool should ensure only rotation of the mandrel and also the necessary force of pressure on the roller and assigned feed. Special machines for press works manufactured at present by industry have very rigid construction, powerful drives, one, two and more hydrosupports, devices for a smooth change in feed in the process of pressing, limit switches with automatic rapid tap of the supports and tailstock. Machines with program control of the whole cycle of extrusion of complex parts are also manufactured.

§ 7. Stretching by a Releasing Punch

The manufacture of parts of the type shown on Fig. 2.13 by the method of deep drawing in stamps from sheet bars is associated with great labor costs and time, since for every part a set of expensive stamps is required. The obtaining of such parts by rolling from a sheet is also difficult since deep deformation of the material with intermediate heat treatment is required. Meanwhile the technological process considerably will be simplified if one were to take the billet not flat but in a form approaching the form of a finished part, as is shown by the dashed line on Fig. 2.13. Then the degree of deformation of the metal will be considerably less and, consequently, the process of molding will be simpler.



Fig. 2.13. Standard parts obtained by stretching by a releasing punch.

The technological process of obtaining thin-walled parts of complex form - type of shown on Fig. 2.13, from billets of simple geometric form approaching the form of a finished part can be carried out by means of nonuniform stretching of the billet on special releasing rigid punch [1]. A diagram of stretching is shown on Fig. 2.14.

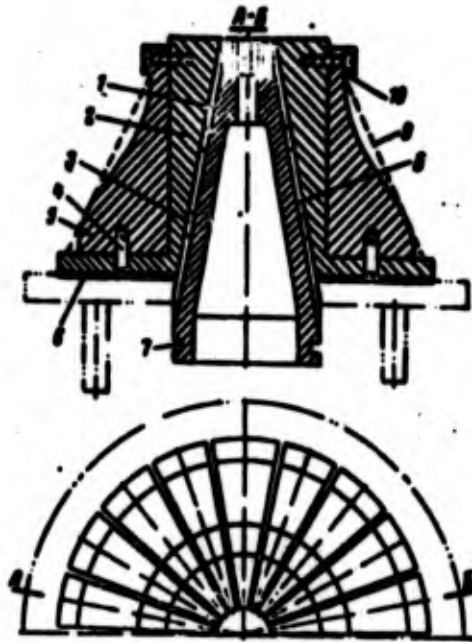

Fig. 2.14. Diagram of the stretching of parts. 1 - cone; 2 - transition sectors; 3 - guide stripe; 4 - pin; 5 - shift sector; 6 - lining; 7 - groove for bracing; 8 - groove; 9 - billet; 10 - stop.

The punch consists of a cone 1, transition sectors 2 and shift sectors 5. The billet 9 is set on the shift sectors, which form the shape of the part. On the figure a cone billet and shift sectors in the form of a transition part of the KS are shown.

To prevent axial shift of the billet during stretching on the shift sectors, a stop is provided 10. With motion of the cone upwards (or transition and shift sectors downwards) the sectors will be opened and will stretch the billet. The transition sectors are secured on the cone and move along guides 3. Movement of the cone is carried out by a standard hydraulic press or special device. After releasing (removal of the load) due to elastic deformations the part somewhat decreases in dimensions, which is considered during calculation of diametrical dimensions of the part. The force of pressure of the press P is determined by the formula

$$P = \frac{2\pi s H K \sigma}{A}$$

where s - thickness of the sheet of the billet; H - height of the billet; K - shape factor of the billet: for the cylindrical part $K = 1$, for the convex $K = 0.85$, and for the concave $K = 0.63$; σ - stress in the metal with extension (for small deformations it is possible to take $\sigma = \sigma_0$ (neglecting hardening)); A - coefficient depending on angle α of the cone and coefficient of friction f between the cone and the sectors.

When $\alpha = 10^\circ$ and $f = 0.1$, $A = 3.5$;

when $\alpha = 10^\circ$ and $f = 0.2$, $A = 2.4$;

when $\alpha = 15^\circ$ and $f = 0.1$, $A = 2.5$.

Billets for stretching are obtained from a sheet by means of rolling and welding by longitudinal seam. The welding should be of high quality with the strength of the seam equal to the strength of the basic metal and sufficient viscosity.

During one operation deformation of the part up to 20% with thinning of the sheet of the billet up to 10-11% can be obtained. The degree of deformation depends on the brand of the material of the sheet. For example, stainless steel 1Kh18N9T permits obtaining a degree of deformation of 18-20% and steel 30KhGSA 6-8%.

The accuracy of obtaining the dimensions is quite high. With the stretching of parts with a diameter of 1000-1300 mm the deflection consists of 0.3-0.5 mm. The method can be used for operations of the calibration of the parts.

Besides the aforementioned methods, in recent time new methods of molding have begun to find application, with the help of electric discharges, gas explosions, and magnetic stamping.

§ 8. Shaping of Tubes

For the manufacture of walls of the KS, from a set of tubes, tubes of constant cross section of steel or from nonferrous metals are used. In order to form from the set of tubes the assigned form of the combustion chamber, it is necessary to cut the tubes into measuring segments and to shape them into accordance with the form of the KS. The form of the bend of tubes in length is determined by the shape of the wall of the KS. Figure 2.15 shows the wall of the KS from a set of tubes (a) and form and the section of the separate shaped tube (b).

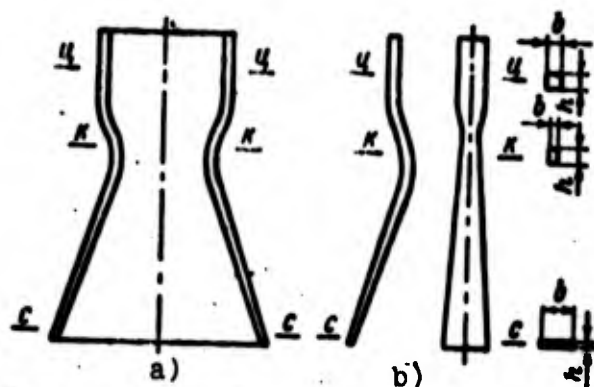

Fig. 2.15. Wall of the KS from a set of tubes.

The cross section of the tube at different places along the length is determined from the condition of tight adjoining of the tubes to one another in each (different in diameter) section of the KS under the condition of identical quantity of the tubes. If the quantity of tubes is n , and the diameter of the section of the combustion chamber is d , then the dimension b of the tube (see Fig. 2.15b) in this section is

$$b = \frac{\pi d}{n}$$

The second dimension h of the section of the tube is determined from the condition of equality of length of the circumference of the undeformed tube and length of the perimeter of the tube after deformation, since with deformation of the tube of round section

into a tube of rectangular section the thickness of the metal of the tube is not changed. Consequently,

$$\pi d_p = 2(h + b); \quad h = \frac{\pi}{2} d_p - b.$$

Example. Determine dimensions of tubes in sections α , κ , ϵ of the rocket hydrogen engine. The KS is made simultaneously with a nozzle of 72 longitudinal profiled tubes from stainless steel. The tubes are united by soldering and are wrapped on the outside with fiberglass. Diameters: cylindrical part - 132 mm, critical throat section - 76 mm; nozzle section - 240 mm.

Taking the external diameter of the undeformed tube equal 8 mm, we find the following:

Section	b in mm	h in mm
Cylindrical part (α)	5.8	6.8
Critical throat section (κ)	3.3	9.3
Nozzle section (ϵ)	10.5	2.1

From the given calculations it is clear that with the assigned relationships of the critical throat diameters and section of the nozzle in this the KS all possibilities of deformation of the tube are practically exhausted, since the thickness of the cooling layer of liquid near the section of nozzle is less than 2 mm. Further lengthening of the nozzle will lead to an impermissible narrowing of the coolant passage. If it is necessary to obtain a greater widening nozzle, stacking of short tubes in the intervals between the basic tubes in the end part of the nozzle is used or orifices on the nozzle without internal cooling are made, and on the surface of the nozzle touching the hot gases a protective refractory covering is applied.

The shaping of tubes is conducted in a stamp, which presses the tube in two mutually perpendicular directions. Dimensions of the variable section along the length of the tube must be observed with sufficient accuracy in order to ensure tight adjoining of them to each other with installation on a rigid mandrel. With nonobservance of this condition unsoldered joints can be obtained.

Footnotes

¹hN - hectonewton = 100 newtons \approx 10.2 kgf.

²The method of calculation of the cost is discussed in detail during the study of the subject "Economics, organization and planning of industrial enterprises."

³The rates are accepted conditionally as the example.

⁴Expenditures are accepted conditionally as an example.

C H A P T E R 3

MECHANICAL TREATMENT OF PARTS OF THE COMBUSTION CHAMBER

§ 1. Peculiarities of Treatment

The machining of parts of the KS has two essential peculiarities. The first consists in the fact that the basic parts are of large dimensions and thin-walled possessing low rigidity. Requirements for the accuracy of the treatment of parts and cleanness of the surfaces are high. With the usual fastening on machines such parts are greatly deformed under the action of forces of clamp and forces of cutting, in consequence of which it is impossible to obtain the necessary accuracy of the treatment. Therefore, it is necessary to use special devices, which hold the parts in the needed position and give to them the necessary rigidity during machining.

The second peculiarity is connected with the singularity of the used materials, which hampers their treatment. Highly durable and heat-resistant steel and alloys, titanium alloys, and the material using cobalt, molybdenum, niobium, tantalum, tungsten, and beryllium as bases are used. Treatment of such kind of materials essentially differs from the treatment of the standard steels.

Let us consider the basic peculiarities and recommendation on the treatment of heat-resistant steels and refractory metals. Here we will be guided by investigations and the experience of industry generalized in work [4].

§ 2. Classification of Heat-Resistant Materials
According to the Machinability by Cutting

According to the machinability by cutting, heat-resistant materials are divided into eight groups. The classification is given in Table 3.1.

Table 3.1. Machinability by cutting of heat-resistant materials.

Group	Material	With respect to steel 45
I	Heat-resistant chromium, chromium-silicon and chromium-silicon-molybdenum steel 20KhZMVF (EI415), Kh5M, Kh6SM and others.	0.8
II	Corrosion-resistant (stainless) high-chromium steel 2Kh13, 3Kh13, 4Kh13, 15Kh12VMF, 1Kh12N2VMF (EI961), 1Kh17N2 and others.	0.65
III	Corrosion-resistant acid-resistant heat-resistant chromium-nickel steel Kh18N9T, Kh18N12T, 1Kh21N5T, (EI811), Kh23N18 (EI417), EI69, EI904 and others.	0.5
IV	Heat-resistant, oxidation-resistant and acid-resistant chrome-nickel and chromium-nickel-manganous steel EI481, EI395, EI835, EI696, EI654 and others.	0.3
V	Heat-resistant wrought alloys on iron-nickel and nickel base EI437A; EI437B, EI787, EI617, EI445R, EI827, EI867 and others.	0.15-0.075
VI	Heat-resistant casting alloys VZh36-L2, ZhS6-K and others.	0.05
VII	Alloys on a titanium base VT1, VT3, VT5, VT6, OT4-2, VT14, VT2	0.45 0.25-0.15
VIII	Refractory metals and alloys: niobium, tantalum, molybdenum tungsten	0.4 0.1

From the table it is clear that steels referred to group I are machined quite satisfactorily, differing little in this respect from carbon structural steels.

Steels of group II in an annealed state are machined satisfactorily, but the cleanness of treatment is low due to the remaining of metal on the tool. With an increase in strength as a result of heat treatment, the machinability of the steels sharply decreases two-four times, and the cleanness of treatment is improved.

Steels of group III have obtained widespread use due to the high heat resistance and anticorrosive stability and also good machinability as compared to other heat-resistant steels. The speeds of cutting used are approximately twice lower than the speed of cutting steel 45.

Complex alloy steels of group IV are for manufacture of disks and blades of turbines. The machinability of these steels by cutting is 3-4 times lower than the machinability of steel 45.

The machinability of wrought alloys of group V is very low -- 6-12 times below that of steel 45.

Casting alloys of group VI are close in chemical composition to wrought alloys of group V. However, casting alloys of less malleable, and forces with their cutting are less than with the cutting of wrought alloys.

With the treatment of casting alloys of group VI it is recommended to use a tool equipped with a hard alloy, since carbide inclusions available in alloys lead to rapid wear of the high-speed cutting tool.

The machinability of alloys on a titanium base of group VII depends on the strength of the alloys. At low strength these alloys are quite satisfactorily machined by a tool equipped with a hard alloy. With an increase in tensile strength the machinability rapidly worsens.

Refractory metals and alloys of group VIII are assimilated very little, and their machinability is studied little.

§ 3. Quality of the Surface After Machining

The quality of the surface of parts from heat-resistant materials is governed by their strength under dynamic loads, corrosion resistance, reflectance and other criteria. The quality of the surface is characterized by the height of microroughness, direction and depth of the graduation line from the machining tool, the presence of oxide films, the presence of decarbonized or depleted alloying elements of the layer, deformation of the metal in the surface layer, cold hardening of the surface, residual stresses and other parameters.

The character and magnitude of microroughnesses are determined mainly by the geometry of the cutting edge of the tool, direction of motion of the tool and magnitude of the feed. There is also an influence by deformations in the zone of cutting, vibrations and the phenomenon of separation of the built-up edge, characteristic with treatment of standard structural steels. In the treatment of heat-resistant steels the separation of the built-up edge is not observed, which conditions the best cleanness of the surface. For example, with turning of titanium alloys can be obtained 8th class of cleanness, machining with a cutter with a radius of curvature of 15 mm with a feed of 0.07 mm/rev. In the treatment of certain heat-resistant alloys of high hardness, on the treated surface there appears a waviness with a height of 0.02-0.03 mm, which is the result of the heterogeneity of the structure of the alloys.

A substantial effect on the strength of parts is rendered by residual stress in the surface layer, which are formed with treatment by cutting as a result of nonuniform plastic deformation of the metal under the action of forces of cutting and heating of the surface layer. The removal of these residual stresses is attained by thermal or electrochemical treatment.

Residual stresses can attain great magnitude. For example, lathe treatment causes the appearance of tensile stresses of the order of 300-700 MN/m², and the depth of their propagation lies within 50-200 μm depending upon the feed, back rake angle and wear of the tool [4].

Deformation of surface layers of the metal with cutting leads to cold hardening, i.e., to local hardening of the metal accompanied by a loss in plasticity. The depth of cold hardening is increased with an increase in thickness of the cut layer of metal and magnitude of the feed. However, this is correct only with treatment of hardenable materials. With the treatment steels hardened to a high hardness (HRC 55-57), cold hardening of the surface is not observed.

Experiments establish that the quality of the surface, depending on the form of machining, substantially affects the strength of the parts made from heat-resistant steels and alloys. For example, tests for prolonged strength of the alloy EI437A at a temperature of 700°C showed the following [4].

Table 3.2.

Type of Treatment	Prolonged strength at 700°C, %
Polishing after turning	63
Polishing after grinding	83
Hardening by fraction	49
Grinding with pulling through	76
Clean turning	58
Rolling by rollers	16

Accepted as 100% is the strength of samples which passed electropolishing with sufficient removal of the metal. From the given table it is clear that certain types of treatment are absolutely unfit, since they sharply lower the strength. Therefore, the question of the technology of obtaining parts from heat-resistant steels and alloys, especially by finite operations, is given very much attention.

§ 4. Treatment of Tungsten

Tungsten is the most refractory metal. The temperature of its fusion is 3410°C , density 19.3 mg/m^3 , and tensile strength $1100\text{--}1500 \text{ MN/m}^2$. Tungsten, which is connected with fragility, high hardness and strength, machines badly.

With treatment by cutting chippings on edges of parts are possible. Therefore, before treatment one should grind the faces on both sides by a magnitude of that taken with treatment of the layer. The clamp of the thin-walled parts should be soft and uniform on as large an area as possible.

In the interval of temperatures of $150\text{--}450^{\circ}\text{C}$ both in a fragile and in a plastic state tungsten can be found, depending upon the preliminary treatment and industrial cleanness of the metal. Therefore, is recommended machine parts of a complex shape with preheating up to a temperature of $300\text{--}400^{\circ}\text{C}$. With heating higher than 400°C the tungsten starts rapidly to be oxidized.

For hot-pressed tungsten on the surface a very hard crust will be formed. Removal of this crust is possible by grinding or oxidation by heating in air up to $950\text{--}1000^{\circ}\text{C}$. Treatment of tungsten by grinding on the crust is possible with cutters equipped with hard alloys of the type VK8 and VK15. It is recommended to produce prefinishing and finishing by alloys VK6M and T30K4. The stability of the tool is 1-5 minutes at an optimum rate of cutting. An increase of speed higher than the optimum leads to the welding of the shaving to the cutter and destruction of the plate. The following conditions of cutting are recommended [4].

Table 3.3

Type of treatment	Conditions		
	rate of cutting m/min	feed mm/rev	depth of cutting of mm
Roughing on the crust	3-10	0.5-1	2.5-3
Rough. and prefinishing	20-25	0.3-0.5	0.5-1.5
Finishing	30-40	0.08-0.25	0.2-0.5

With the drilling of holes crumbling and stratification of the tungsten are observed, but the stability of the drills is very low, since tungsten acts as an abrasive. With the diameter of the drill up to 6 mm drills from the alloy VK10M are used, and drills with a diameter of more than 6 mm are equipped with plates of the hard alloy VK8. To increase the stability of the drills, it is recommended to use preheating of the tungsten up to 300-400°C. The rate of cutting when drilling with preheating is 15-20 m/min, and the feed is 0.05-0.1 mm/rev.

It is recommended to grind tungsten by wheels of green silicon carbide with a granularity of 40-50 on a ceramic cluster with abundant cooling and small depth of the fitting. This is caused by the fact that a sharp change in temperature of the surface of the tungsten with grinding leads to the appearance of cracks. The recommended speed of the wheel is 20-25 m/s.

§ 5. Treatment of Molybdenum

Molybdenum has a melting point of 2620°C, density of 10.2 mg/m³, tensile strength - 800-900 MN/m², elongation per unit length - 10-15%. It possesses high strength at high temperatures, high elastic modulus (3.3·10⁵ MN/m²), high thermal conduction, and a small coefficient of linear expansion.

The machinability of molybdenum is better than that of tungsten and depends on the cleanness of the metal and method of its obtaining. With treatment by turning cutting tools with plates of hard alloy VK6M are recommended. The magnitude of the back rake angle is selected within 12-18° and relief angle 10-12°.

Tentative values of conditions of cutting are given in Table 3.4 [4].

Table 3.4.

Type of treatment	Rate of cutting m/min	Feeds mm/rev	Depth of cutting, mm
Prefinishing turning	80-120	0.2-0.3	1-4
Finishing turning	90-140	0.15-0.20	Up to 1

Drilling of holes up to 10 mm is produced with drills from a hard alloy BK10M and holes over 10 mm with drills equipped with plates of hard alloy VK8. It is possible to use also drills from the high-speed cutting steel R9K5 and R18. The rate of cutting with drilling is 15-20 m/min with the stability of the drill of 10-15 min and feed of 0.02-0.3 mm/rev.

§ 6. Treatment of Niobium and Tantalum

The melting point of niobium is 2415°C, density - 8.57 mg/m³, tensile strength - 300-400 MN/m². It possesses high plasticity (elongation 25-40%) and retains plasticity at high temperatures. It is more stable to oxidation than molybdenum is, and it possesses high stability under a cyclical load in a heated state.

The melting point of tantalum is 2996°C, density - 16.6 mg/m³, tensile strength - 250-350 MN/m², elongation - 40%. With respect to plasticity and corrosion resistance tantalum is close to that of platinum, and it possesses high thermal conduction and a small coefficient of linear expansion.

Niobium and tantalum are relatively easily machined by cutting. However, the high viscosity of these metals leads to the remaining of metal on cutting edges of the tool and, as a result, to the formation of scores.

To decrease sticking lubricating liquid coolants (for example, a mixture of sulfurized oil 60%, kerosene 25% and olenic acid 15%) are used.

Treatment is conducted at cutting rates of 40-70 m/min and feeds of 0.15-0.4 mm/rev with prefinishing turning and 0.08-0.15 mm/rev with finishing.

§ 7. Facing of Thin-Walled Parts of the KS

The treatment of faces of thin-walled parts of the KS is fulfilled both after stamping for the levelling off of edges and in the process of further treatment of the parts. The shape of the machined edge can be different depending upon conditions of the butt welding with another part. The thin-walled parts proceeding for surfacing can be somewhat deformed and not have the correct geometric form. With facing it is necessary that the plane of the face be perpendicular to the true geometric axis of the part in that form which it should have ready for use.

For the purpose of providing this condition the devices for facing should give to the part that form which it should have when working in the construction of the subassembly and secure the part on the machine in such a way so that the axis of the part coincides with the axis of the spindle of the machine. The axis of the part of the cylindrical and conical form is a line connecting centers of the circumferences of two face sections of the part.

The condition of basing of the part with treatment emanates from these basic positions. Two sections near faces of the part are taken as bases.

Figure 3.1 shows examples of the selection of bases with facing of cylindrical and conical parts (base sections are designated B). For the possibility of light installation of part, support elements of the devices in these sections must have somewhat smaller diameters than diameters of the part, but with fastening the support elements must increase their diameter, retaining the form of the circumference. This condition is satisfied by clamp mandrels, unclamped jaw devices and other structures.

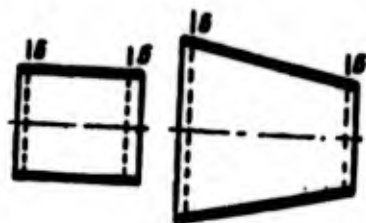

Fig. 3.1. Basing of thin-walled parts with facing.

Jaw devices for facing in principle are similar to devices for welding, the operation of which will be examined in Chapter IV. It is necessary to stress that the unclamping on two belts of basing should be separate and mutually not connected, since deviations in dimensions on base diameters within limits of the allowance for manufacture of the part can lead to an unstable position of the part: on one section it will be secured, and on a second it is free within limits of the allowance.

With fastening of the conical part by the method unclamping jaws there appears an axial force, depending on the magnitude of conicity, which tries to shift the part in the direction of the vertex of the cone. This force is balanced by the frictional force appearing between the part and jaws of the fitting. With small conicity the frictional forces considerably exceed the axial force, and there is no danger of a shift of the part. With great conicity additional bracing of the part in an axial direction is required. It can be carried out by different methods in reference in specific part.

Figure 3.2 gives the design diagram of the devices for facing of the conical part with bracing by a clamp slipped on. The part 1 subject to facing is set on the cone disk 2, which is rigidly secured on axis 3. In the second base section the part rests on disk 4 mobile in an axial direction. With treatment of face A the part is held by collar 6, pressed by folding bolts 7. After treatment of face A the part is folded by clamp 5, and the lathe dog 6 is taken, after which it is possible to treat face B. Bracing of the lathe dog 6 can be fulfilled by another method, for example, in the form of fork on tailstock of the machine.

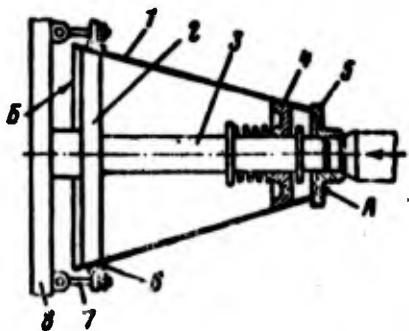

Fig. 3.2. Diagram of the fitting for facing of thin-walled cone parts. 1 - machinable part; 2 - fixed cone disk; 3 - axis; 4 - mobile disk; 5 - clamp; 6 - lathe dog; 7 - folding bolt; 8 - face plate.

§ 8. Treatment of Contour Parts

Treatment on the external and internal contour of parts of the KS is conducted for the purpose of achievement of the necessary accuracy of mating dimensions and assigned cleanness of the surface. The shape of the contour is determined by the design of the subassembly and is assigned by the drawing. The turning of complex shapes is fulfilled on hydrocopying machines with the fastening of the parts in special fittings.

With the treatment of thin-walled parts from stamped, cast or other thin-walled billets, one should consider deformations of the parts during treatment as a result of the redistribution of internal stresses in the material of the billets. In the obtaining of the billets on the surface of the material a surface layer, the strength and hardness of which can considerably differ from these indices of the basic metal will be formed. In this layer there are internal stresses of compression or extension depending upon the method of obtaining of the billet. In the basic material of the billet there appear also internal stresses both as a result of the balancing of stresses of the surface layer and of the action of the tool with stamping, nonuniform cooling and other factors.

All internal stresses in the material of the billet are mutually balanced, giving to the billet a fully defined form, not always coinciding with the needed form of the finished part. With machining of the billet a layer of metal departs from the internal or external side, which leads to the redistribution of internal

stresses in the remaining part of the metal, and the part is deformed. Deformations are increased still in connection with the fact that the thickness of the taken layer along contour is nonuniform (Fig. 3.3). These phenomena considerably complicate the technology of obtaining of exact thin-walled parts.

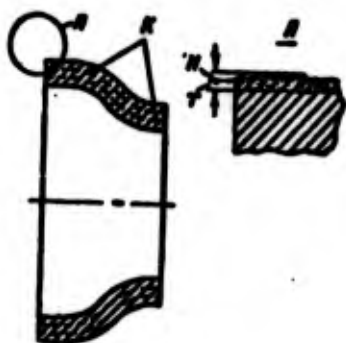

Fig. 3.3. Diagram of the machining of a thin-walled part along the contour. H - height of unevennesses; T - depth of damaged layer.

The required accuracy of the dimensions and form of thin-walled parts depends on the subsequent technological process and design of the subassembly. Let us consider two cases.

1. The form of the part in the subassembly is determined by other rigid parts adjoining it. In this case treatment of the thin-walled part can be conducted in fittings preserving the necessary form of the part in a forced state. The part treated in such a way in its form in a free state can considerably differ from the form of this part in the subassembly. For example, the thin ring pressed on the rigid part can in a free state take the form of an ellipse, which will not be reflected on the efficiency of the subassembly. It is important that the length of the circumference of this ring (or diameter with treatment in a forced state) is in the assigned tolerances.

2. The form of the part in the subassembly is determined basically by the form of part in a free state. For example, the form of the uncooled orifice of the nozzle to a considerable degree is determined by the form of parts in a free state. In this case

treatment of the parts one should be conducted taking into account deformations under the action of internal stresses in the metal. The order of treatment is approximately the following. The billet is secured in a special fitting without considerable deformations, preserving basically its natural form. We take (by machining) a certain layer of the metal from the external or internal side and unfasten it. Here the billet is deformed, taking another form. Then it set again without considerable deformations for treatment on the other side and again unfastened. By such an alternating of treatment the parts in a free state - first on the outside, then on the internal side - gradually approach to dimensions of the finished part. The quantity of operations and thickness of the taken layer of metal in every operation are determined by experimental means. Here one should consider that for the full redistribution of internal stresses in the metal a definite time - time of aging is required. Acceleration of the process of aging is attained by an increase in temperature up to a defined value (artificial aging).

§ 9. Measurements of Dimensions of Thin-Walled Parts

Due to low rigidity the geometric form of thin-walled parts in a free state differs from the form of finished parts. Furthermore, with measurement the parts can be additionally deformed under the action of measuring tools. Therefore, measurement of dimensions of such parts is associated with certain difficulties. In thin-walled parts of the KS deformation in majority cases is radial: circumferences take the form of ellipses or a more complex irregular shape. If deformations as compared to measured diameter are small, then the true diameter of such a circumference can be found as the mean value of several measurements with respect to mutually perpendicular directions. Such an assumption is based on the fact that, the length of the circumference insignificantly differs from the length of the perimeter of an ellipse, if the difference between the diameter of a circle and axes of an ellipse is small.

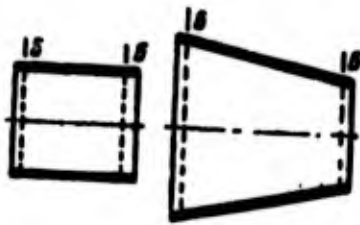

Fig. 3.1. Basing of thin-walled parts with facing.

Jaw devices for facing in principle are similar to devices for welding, the operation of which will be examined in Chapter IV. It is necessary to stress that the unclamping on two belts of basing should be separate and mutually not connected, since deviations in dimensions on base diameters within limits of the allowance for manufacture of the part can lead to an unstable position of the part: on one section it will be secured, and on a second it is free within limits of the allowance.

With fastening of the conical part by the method unclamping jaws there appears an axial force, depending on the magnitude of conicity, which tries to shift the part in the direction of the vertex of the cone. This force is balanced by the frictional force appearing between the part and jaws of the fitting. With small conicity the frictional forces considerably exceed the axial force, and there is no danger of a shift of the part. With great conicity additional bracing of the part in an axial direction is required. It can be carried out by different methods in reference in specific part.

Figure 3.2 gives the design diagram of the devices for facing of the conical part with bracing by a clamp slipped on. The part 1 subject to facing is set on the cone disk 2, which is rigidly secured on axis 3. In the second base section the part rests on disk 4 mobile in an axial direction. With treatment of face A the part is held by collar 6, pressed by folding bolts 7. After treatment of face A the part is folded by clamp 5, and the lathe dog 6 is taken, after which it is possible to treat face B. Bracing of the lathe dog 6 can be fulfilled by another method, for example, in the form of fork on tailstock of the machine.

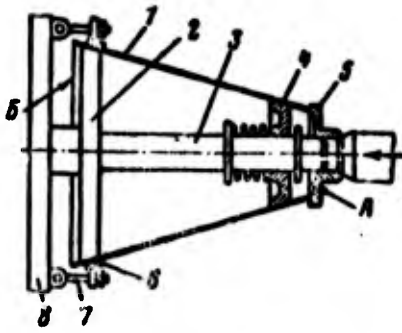

Fig. 3.2. Diagram of the fitting for facing of thin-walled cone parts. 1 - machinable part; 2 - fixed cone disk; 3 - axis; 4 - mobile disk; 5 - clamp; 6 - lathe dog; 7 - folding bolt; 8 - face plate.

§ 8. Treatment of Contour Parts

Treatment on the external and internal contour of parts of the KS is conducted for the purpose of achievement of the necessary accuracy of mating dimensions and assigned cleanness of the surface. The shape of the contour is determined by the design of the subassembly and is assigned by the drawing. The turning of complex shapes is fulfilled on hydrocopying machines with the fastening of the parts in special fittings.

With the treatment of thin-walled parts from stamped, cast or other thin-walled billets, one should consider deformations of the parts during treatment as a result of the redistribution of internal stresses in the material of the billets. In the obtaining of the billets on the surface of the material a surface layer, the strength and hardness of which can considerably differ from these indices of the basic metal will be formed. In this layer there are internal stresses of compression or extension depending upon the method of obtaining of the billet. In the basic material of the billet there appear also internal stresses both as a result of the balancing of stresses of the surface layer and of the action of the tool with stamping, nonuniform cooling and other factors.

All internal stresses in the material of the billet are mutually balanced, giving to the billet a fully defined form, not always coinciding with the needed form of the finished part. With machining of the billet a layer of metal departs from the internal or external side, which leads to the redistribution of internal

Let us show this in an example.

The length of the circumference $L_0 = \pi D$.

The length of the perimeter of the ellipse $L \approx \pi \sqrt{2(a^2 + b^2)}$,
where a and b - semiaxes of the ellipse.

Let us measure the diameter of the circle of 500 mm.
Measurements showed that a = 255 mm, b = 245 mm. At these values

$$L = \pi \sqrt{2(255^2 + 245^2)} = \pi 500.$$

Consequently, with deformation of the circumference at 10 mm the error in measurement of the true diameter is not more than 0.1 mm. Such great deformations in practice are not encountered. With smaller deformations the measuring error by the method of average diameter will be small, commensurable with the precision of the tool.

The second method of the determination of the true diameter of the deformed circumference consists in the measurement of its length with subsequent conversion to the diameter of a circle. Measurement of the length of the circumference at any arbitrary deformation of it can be produced by a flexible tape with graduations. The tape should tightly adjoin to the surface of the part.

The third method is the measurement of length of the perimeter of the part by rolling (without slip) by a roller in the assigned section. By knowing the diameter of the roller and number of revolutions for one bypass of the perimeter, it is easy to calculate the length of the circumference and diameter of the part. There are special instruments which directly show the length of the measured perimeter (circumference).

CHAPTER 4

ASSEMBLY OF SUBASSEMBLIES OF THE COMBUSTION CHAMBER

§ 1. Assembly of Walls

Treated in accordance with drawings and technical conditions parts of the KS are assembled into the subassembly for connection by their welding, soldering or other methods. The most important and responsible is the assembly of the central part of the chamber. The form of this assembly is determined by the design of the KS and method of connection of the parts. Let us consider certain characteristic subassemblies and methods of their assembly.

Methods of the assembly of the wall depend on by what means grooves or channels for the liquid coolant will be formed. If grooves are formed in the whole metal by milling, etching, pressing or other method, then the wall ready for use proceeds directly for the assembly with other parts. If, however, the wall has tubular construction or is formed by Π -shaped profiles, then it passes a number of operations of the assembly. As was already noted, tubular construction of the wall is the most widespread in foreign rocket building. Tubes for assembly proceed shaped and prepared for assembly and soldering. The assembly is conducted on a rigid mandrel, which has the form of the corresponding part of the combustion chamber. The design of mandrels can be different.

Figure 4.1 shows one of the possible variants of design on the mandrel. Shaped tubes are set on the mandrel close to one another, are pressed tightly to the mandrel and secured by industrial rings. Connection of the tubes with each other is produced by soldering on the mandrel. After soldering the mandrel is removed from the wall. For this purpose the mandrel is made separable, which consists of lower and upper parts which are connected with the help of a tightening device and disk. Solder for the soldering of the tubes is applied preliminarily on external surfaces of the tubes by electrolytic deposition, spraying or other method. Tubes, plated by solder, i.e., having on the external surface layers of solder obtained with the manufacture of the tubes are also used.

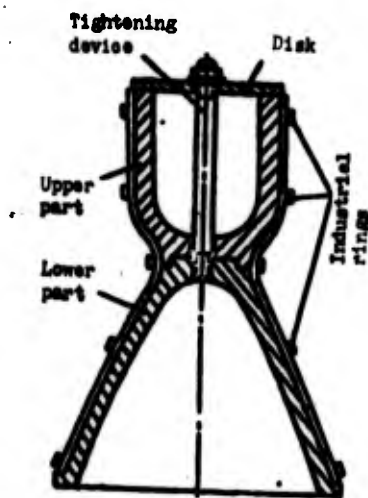

Fig. 4.1. Mandrel for the assembly of a KS of tubular construction.

The basic difficulty with the assembly of tubes on a mandrel for soldering consists in the necessity to ensure the tight adjoining of the tubes both to one another and to the mandrel over the entire surface of the wall. If between the tubes great clearances will be formed, then the tube will not be soldered and at this place a slot will be formed. If the tubes are not pressed tightly to the mandrel the contour of the wall will differ from the calculation, which can be reflected on the dynamics of the gas flow.

The density of the adjoining of the tubes to one another is determined by tolerances on dimensions of the shaped tubes. The quantity and nominal dimensions of the tubes are determined by simple calculation proceeding from the assigned diameter of the section of the KS, which was already discussed earlier. But in production nominal dimensions are encountered very rarely. Actual dimensions are different within limits of the assigned field of the allowance. A set of these real tubes is not able to be placed into the assigned length of the circumference or be placed with the clearance.

Let us consider this question in greater detail on a diagram (Fig. 4.2). Let us assume that in the section with diameter D it is required to place n tubes. The nominal dimension of the width a of the tube along the circumference adjacent to the mandrel

$$a = \frac{\pi D}{n}$$

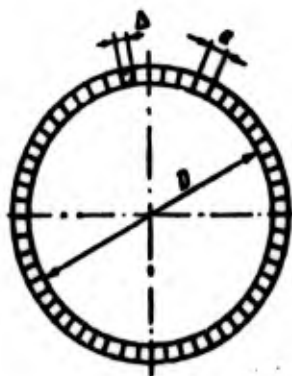

Fig. 4.2. Diagram of packing of tubes.

The allowance on width a will be taken equal to $\pm\delta$.

If one were to take all tubes with a lower allowance and place them along the circumference on the mandrel, then between the first and last tubes there will be formed a clearance Δ equal to

$$\Delta = n\delta$$

As can be seen, the magnitude of the formed clearance is directly proportional to the allowance for the width of the tube and quantity of tubes.

At the large number of tubes the clearance can be impermissibly great. Let us show this in an example.

The nozzle of the combustion chamber of the American hydrogen engine J-2 is formed from 540 tubes with a width near the section of the nozzle 11.9 mm. If one were to fulfill this dimension with respect to the second class of accuracy, i.e., $11.9_{-0.012}$, then the maximum clearance between the first and last (locking) tubes will be $\Delta = \delta n = 0.012 \cdot 540 = 6.48$ mm, which is absolutely impracticable.

However, in practice in industrial conditions the clearance will be less, since the majority of the tubes according to the theory of probability will have an average magnitude of allowance and not a maximum, as is accepted in the example. For calculations of the magnitude of clearance with a large quantity of tubes (more than 50), it is possible to take

$$\delta_{\text{pract}} = \frac{2}{3} \delta.$$

Under this condition for the example examined above

$$\Delta_{\text{pract}} = \frac{2}{3} \delta n = \frac{2}{3} \cdot 6.48 = 4.3 \text{ mm.}$$

In order to avoid this clearance and pack the tubes close, one should take a number of industrial measures. On the basis of practical measurements or preceding experience we determine the field of dispersion of dimensions of tubes and center of bunching of dimensions (axis of symmetry in a Gaussian curve). On the basis of these data we correct the nominal dimension of the width of the tube with such calculation in order that with this dimension and the most probable allowance (near the center of bunching) the tubes are packed on ingots with a certain negative allowance. This negative allowance is selected in the process of packing due to a certain deformation of

the tubes (upsetting of width of the tubes). In order that the upsetting is uniform and not too great for one tube, it is necessary in process of packing to produce control measurements of the length of the arc of the packed tubes. These measurements can be produced according to control risks on a mandrel or special patterns. When the pack of tubes is collected, it is necessary to check whether or not there are impermissible clearances between the tubes and density of adjoining to the mandrel. The magnitude of the clearances can be determined by a thickness gauge. The magnitude of the allowed clearance is determined by experimental means from requirements of good soldering. The selection of optimum clearances with soldering will be discussed in Chapter 6.

The assembly of the wall of the KS from Π -shaped profiles is analogous to the assembly of the wall of tubular construction. A peculiarity is the fact that with the stamping of profiles the height of the folded edges is different in various sections; in one section on one side the edge can be higher than on the other. As a result of this with packing on an ingot one edge is obtained higher and the other lower, as is schematically shown on Fig. 4.3. If on such a wall one puts on a jacket and solders it, then the connection will be only on the most protruding edges, and in certain places there will be formed slots, which promote the overflowing of liquid coolant from one channel into the other, which will disturb the uniformity of cooling. In unsoldered places the wall is not connected with the jacket and, consequently, its strength is considerably weakened. Furthermore, the different height of the protruding edges of the wall leads to an indefinite dimension of the diameter coupled with the jacket, which hampers the assembly. Therefore, for the levelling off of the external profile machining of the contour of the wall after soldering of profiles is used. Machining is fulfilled on a hydrocopying lathe. To create rigidity to edges of the profiles, preliminary filling of grooves with heated plastic is produced, as was shown on Fig. 4.3. At normal temperature (20°C) the plastic hardens and durably supports the edges during machining.



Fig. 4.3. Diagram of the levelling off of the contour of the wall of the KS from II-shaped profiles.

Machining is conducted up to the assigned dimension II from the condition of mating with the jacket.

After the machining of the contour of the wall the plastic departs by means of preheating. The plastic should possess sufficient strength at normal temperature, and upon heating it should again turn into a liquid state and not interact chemically with the metal of the wall.

§ 2. Assembly of the Jacket

Placed on the finished wall is the jacket. With respect to its design, the jacket can be both solid, adjacent over the whole contour to the wall, and in the form of separate rings or in the form of the winding from steel tape or fiberglass impregnated by hardening plastic.

The jacket on the wall of the shaped tubes serves only for the creation of strength of the chamber or nozzle. Together with the wall absorbs the pressure of gases inside the KS. The jacket on a wall from II-shaped profiles (or on a wall with open grooves) should, furthermore, be tightly connected by soldering, welding or other method with edges of the profiles, creating channels for passage of the liquid coolant. This causes a need to seek with the assembly tight adjoining of the jacket to the surface of the wall for the purpose of the creation of conditions for soldering or another

connection. The allowed clearances are determined by technology of soldering. To ensure the required (by technology) soldering of the connection of the wall and jacket with guaranteed fitting, it is necessary to designate the appropriate allowances on the dimension of external diameter of the wall and internal diameter of the jacket. These allowances due to necessity must be very rigid, which complicates the process of manufacture of the wall and jacket.

With a solid jacket for the control of clearances between the wall and jacket, it is necessary to use indirect methods of measurement, since there is no direct access by the measuring tool to the place of the formed clearance.

With the manufacture of the wall from tubes the jacket does not have to be solid and can be made from separate rings. In this case the process of manufacture of the jacket and control of density of adjoining of the jacket are facilitated, since between the separate rings intervals which allow taking direct measurement of the clearances will be formed.

With fulfillment of the jacket by the method of winding of steel tape or fiberglass, the allowances on the external diameter of the wall can be increased, since tight adjoining of the jacket is guaranteed by the very method of winding. The quantity of layers and thickness of the tape are assigned by the designer, proceeding from the calculation of strength of the KS. In the process of winding it is necessary to fasten the tape to the jacket, which guarantees against shifts in the tape in the process of winding or with subsequent operations. The turns are connected with each other and with the wall of the KS of soldering. Solder is preliminarily deposited on the tape or in the form of tape is reeled together with the winding of the steel tape.

The winding of fiberglass on the surface of the wall is produced on special machines. The method of superposition of fibers can be different :

1) peripheral location of the fibers, i.e., at an angle of 90° to the axis of the KS;

2) peripheral location with longitudinal layers;

3) spiral location of the fibers.

The selection of a certain method is determined by conditions of strength of the KS. The simplest is the first method. In this case the machine for winding is similar to the lathe (frequently re-equipped lathes are used). A machine for spiral winding is somewhat more complex.

The impregnation of the fiber by resin can be carried out by different methods.

The first method consists in the fact that the fiber is impregnated in a reeled form. Winding is produced by a dry fiber. This method is simple, but it does not provide high strength and therefore is not recommended.

According to the second method impregnation of the fiber is carried out directly before the winding by means of the drawing of a dry fiber through a bath with liquid resin ("wet winding"). The method provides satisfactory strength, but it is hardly productive since the speed of drawing of the fiber through the resinous bath is limited. At high speed the resin does not evenly envelop the surface of the fiberglass.

The third method is the preliminary impregnation of the fiberglass by resin with drying. Winding in such a way ensures high productivity and good quality of the jacket.

The application of fiberglass for jackets of combustion chambers and for other vessels working under pressure is given great importance due to the high specific strength of the fiberglass.

§ 3. Assembly of Collectors and Rings of Rigidity

The method of the assembly of collectors and rings of rigidity is determined by their design and position on the jacket of the chamber. If the configuration of the chamber permits putting on a collector or ring as one piece without a joint, then the technology is simplified. In this case the rings and collectors are made separately and move for assembly in finished form. In necessary cases adjoining parts are welded to them. The edges in places of adjoining to the jacket are prepared for welding, soldering or another form of connection. Figure 4.4a shows the assembly of a collector and rings of rigidity on the nozzle cooled part of the chamber.

The configuration of the nozzle permits freely installing the collector 2, rings 1 and 3 and other similar parts. The form of the collector is determined by the contour of the nozzle. Preliminarily welded to the collector are branch pipes for the feed of liquid coolant.

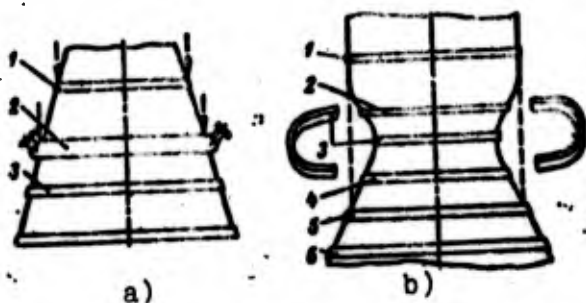

Fig. 4.4. Installation of the collector and rings of rigidity.
a) on the nozzle part: 1, 3 - rings;
2 - collector; b) on the central part:
1, 5, 6 - one-piece rings; 2, 3, 4 -
slotted rings.

Figure 4.4b shows a diagram of the installation of split rings of rigidity on the central part carried out simultaneously with the nozzle cooled part from the set of tubes. In this case the form of the chamber does not permit putting on rings 2, 3 and 4 as one piece and it is necessary to make them slotted. Rings 1, 5, 6 and others located lower are freely put on as one piece.

CHAPTER 5

WELDING OF PARTS AND SUBASSEMBLIES OF THE COMBUSTION CHAMBER

§ 1. Basic Requirements

To connect parts and subassemblies of the KS such forms of welding which ensure high strength and airtightness of the seams are used. The strength of the welded seam should be equal to the strength of the basic metal. The allowable but undesirable lowering of the strength of the seam is limited by several percent, and in specially important places it is absolutely not allowed. Thin walls of combinable parts create additional difficulties, since with a small thickness even small deflections from the assigned conditions of welding lead to overburning, poor penetration or other flaws in welding.

Basically joint welding of edges well fitted to one another is used. The magnitude of the clearances is determined by the form of welding. In certain cases gapless fitting of the parts is required. Conditions of welding must be well worked out and checked, and in process of welding the basic parameters must be maintained automatically in strictly assigned limits. Welded edges must be thoroughly cleaned and have no contaminations.

The following forms of welding are used:

1. Automatic welding under a layer of flux.

2. Argon arc welding.
3. Plasma welding.
4. Welding by electron beam in a vacuum.
5. Diffusion welding.
6. Welding by a light beam.

The selection of a certain method of welding depends on properties of welded metals and on structure of the connection. Of great importance in the selection of the form of welding is the concentration of energy in the zone of welding. If energy during welding is concentrated in a small volume, then the melting of the metal occurs only directly at the place of contact of the parts, but neighboring layers of the metal remain cold. If, however, the concentration of the energy is low, then there occurs heating of a large mass of the adjacent metal, which leads subsequently with cooling to warping of the parts, change in structure of the metal, the appearance of cracks and other troubles. By experimental means it is found that the density of energy in an acetylene oxygen flame is equal to 50 kW/cm^2 , in a welding arc - 100 kW/cm^2 , and in an electron beam - about $500,000 \text{ kW/cm}^2$.

With welding by an open arc the bandwidth of the heated metal along the seam (zone of heating) attains 30 mm. With welding by an arc under a layer of flux, the zone of heating decreases twice, and with welding by an electron beam the zone of heating is only about 2 mm. Hence, naturally, there is high quality of welding by an electron beam. In certain structures welded seams are located inconveniently, and the access to them are only by narrow slots. In these cases the electron beam or light beam are irreplaceable, since all other forms of welding inevitably heat and fuse the edge of the parts located above the welded seam.

With welding in unprotected conditions, i.e., with the access of atmospheric air, the melted metal in the zone of welding, being at a high temperature, is intensely oxidized by oxygen of the air and forms harmful connections with nitrogen of the air. Therefore, with qualitative welding it is necessary to protect the zone of welding from the effect of air, creating a local environment, not affecting the quality of the welding, which drives away the air.

Methods of the protection of welding from atmospheric air will be examined subsequently with a description of different methods of welding.

§ 2. Automatic Welding Under the Layer of Flux

With welding under a layer of flux, the heating up and fusion of the welded metal and electrode are produced by the heat of an electrical arc, which burns between the welded metal and electrode under the layer of flux. The flux is melted, forming a liquid slag, which closes the zone of welding and protects the metal from oxidation by atmospheric air.

The specific gravity of slag is considerably less than the specific gravity of metal, and therefore slag is not introduced into the melted metal but remains on the surface. With the advance of the arc the melted metal and slag congeal. The slag forms a dense crust on the surface of the seam, which after cooling easily departs. A diagram of welding under a layer of flux is depicted on Fig. 5.1.

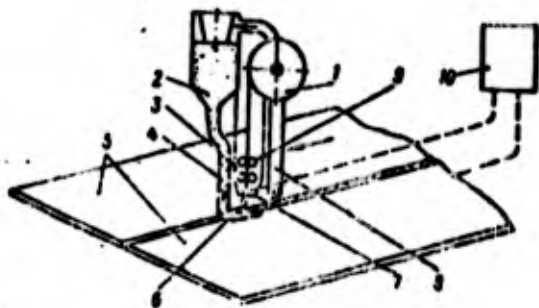

Fig. 5.1. Diagram of welding under a layer of flux: 1 - holder of welding wire; 2 - bin for flux; 3 - feed mechanism; 4 - pipe for flux; 5 - welding parts; 6 - electrode; 7 - orifice; 8 - suction pipe; 9 - feed rollers; 10 - generator.

The welding torch has a holder 1 for welding wire, bin 2 for the flux, and a feed mechanism 3. The parts 5 to be welded are fitted one to another and held in such a position that the seam is disposed horizontally.

A d-c generator 10 is connected to welded parts. The second pole through the orifice 7 is fed to electrode 6. Between the electrode and welded metal an electrical arc appears. The end of the electrode is gradually melted, and to maintain the arc the feed of the electrode by rollers 9 is produced. The motion of the head on the figure is front right to left. Flux is poured at a place of the joint before the zone of welding by gravity flow through pipe 4 from bin 2. The remaining unfused unnecessary flux is sucked back into the bin along the suction pipeline 8.

Figure 5.2 shows the design of one of the welding heads for automatic welding under the layer of flux.

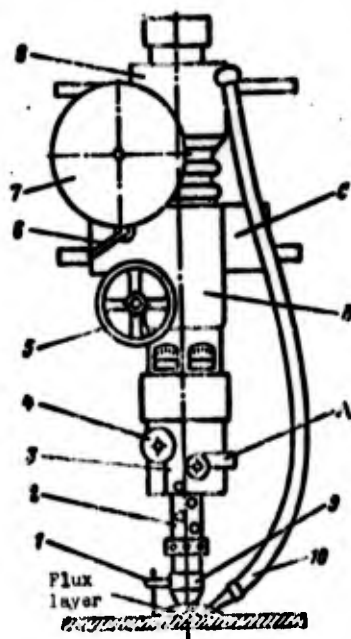

Fig. 5.2. Welding apparatus
 ABS: 1 - indicator; 2 -
 orifice; 3 - feed mechanism
 of the wire; 4 - corrector;
 5 - flywheel of vertical
 lift; 6 - handle of friction
 clutch; 7 - holder of filler
 wire; 8 - bin of flux; 9 -
 directing funnel; 10 - hose
 of flux suction; A - suspen-
 sion welding head; 5 - bin
 with flux apparatus; C -
 self-propelled hopper.

The quality of welding in many respects depends on the composition of the flux. Besides protection of the melting pool from air, the flux ensures the required chemical composition and mechanical properties of the metal of the seam, increases the stability of burning of the arc, and ensures good formation of seam.

The flux is released in the form of a loose granular substance, which is prepared from a mixture of sand, manganese ore, dolomite, fluorspar, chalk and other minerals.

Our industry manufactures standard fluxes recommended for the welding of different steels and nonferrous metals (All Union Government Standard (GOST) 9087-59); fluxes FTs-4, AN-348A for the welding of low-carbon steels; FTsL-2 - for the welding of stainless steels (for example, 1Kh18N9T); AN-20 - for the welding of alloyed steels and copper, etc. One should select the flux by following special literature and experience of production in accordance with the brand of the electrode wire and material of the welded parts.

For automatic welding the electrode wire is supplied in coils. The wire is prepared by cold rolling with an allowance in diameter of not more than 0.12 mm. The surface of the wire should be clean and smooth.

§ 3. Argon Arc Welding

For the protection of the molten metal of the seam from the harmful influence of the atmospheric air, welding can be conducted in a medium of protective gas, not entering into reaction with the metal of the seam. Such a medium is created only directly in the zone of welding in the form of a surrounding cloud by means of a continuous feed of gas.

As protective gases argon, helium, nitrogen, carbon dioxide, hydrogen and steam are used. With high-quality welding of thin-sheet metals the greatest application is with an inert gas - argon. Such welding is called argon arc. The welding is carried out by a welding head, which has a feed mechanism of filler wire and a turner. In

this burner the electrode passes through an annular nozzle, through which the argon is continuously fed. A diagram of argon arc welding is shown on Fig. 5.3.

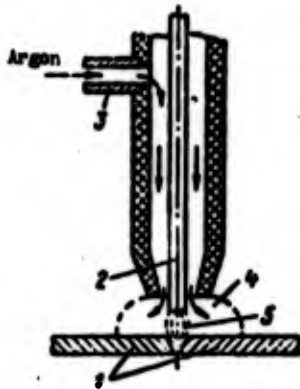

Fig. 5.3. Diagram of argon arc welding:
1 - parts to be welded;
2 - electrode; 3 - pipe connection; 4 - protective cloud; 5 - arc.

Argon arc welding with a consumable or nonconsumable electrode is used. In the first case the electrode is a filler wire toward the end of which through sliding contacts the voltage is fed. In the second case the voltage is fed on the refractory tungsten electrode, which, in forming the arc, is not melted. The filler wire moves on the side into the zone of the arc, is melted, and drops of liquid metal flow into the welded seam. The filler wire is selected depending upon the brand of the metal of the welded parts.

For high-quality welding of thin-sheet steel only pure argon is used. The use of commercial argon, which contains much nitrogen and about 0.4% oxygen, is impermissible. Especially high requirements for the cleanness of argon are required with the welding of stainless steel 1Kh18N9T, which has titanium in its composition. In the welding of this steel nitrogen, which contained in the argon surrounding the zone of welding, enters into chemical reaction with the titanium found in the melted metal. As a result of this reaction stable nitrides will be formed. Welded seams with the connected titanium become less stable to intercrystalline corrosion. Furthermore, impurities in the argon promote the appearance of hot cracks. The composition of argon of different brands is given in Table 5.1.

Table 5.1. Composition of argon (according to the All Union Government Standard 10157-62).

Brand of argon	Argon, not less than %	Oxygen, not more than %	Nitrogen, not more than %	Moisture at pressures of 60 mm Hg, not more than g/m ³
A	99,99	0,003	0,01	0,03
B	99,86	0,005	0,04	0,03
C	99,90	0,003	0,10	0,03

Pure argon is stored and transported in cylinders under the pressure of 150 atm (gage). Every cylinder has a log book in which the chemical composition of the argon, the date of filling and number of the cylinder are indicated.

Argon arc welding can be conducted by the manual or automatic method.

The manual method of welding is used only when it is impossible to use automatic welding: short seams, constrained condition. Here rate of movement of electrode along the seam is very difficult to maintain uniform, which lowers the quality of the welding. Therefore, where conditions permit, movement of the welding head should be produced automatically, i.e., automatic welding should be used.

With argon arc welding of thin-sheet steel, it is necessary to maintain strictly conditions of welding worked out on experimental samples.

§ 4. Plasma Welding

With the standard arc welding the temperature in zone of the arc is 5000-6000°C, and the form of the arc is determined by the potential difference and ambient pressure. If the arc is forced to be compressed, then the area of the section of the electron beam will decrease, the energy will be concentrated in a smaller volume and, consequently, the temperature of the arc will rise. By comparatively simple devices it is possible to reach such a compression of the arc

at which the temperature is increased up to 30,000-35,000°C. At such a temperature the gases are ionized, passing into a state of stable plasma, which is a good conductor of electrical current. Such kind of welding is called plasma.

The compression of the arc can be carried out by a magnetic field or other methods. Figure 5.4 shows the method of compression of the arc by walls of the tip and gas stream. The arc appears between the welded metal 1 and tungsten electrode 2 and passes through the narrow nozzle of tip 3. For the purpose of the prevention of fusion of walls of the nozzle under the action of high temperature of the arc, and continuous feed of argon through the pipe connection 4 is produced. The stream of argon flowing in the radial clearance between the arc and the wall of the nozzle, drives away the arc from the wall and additionally compresses it. With the exit from the nozzle the argon will form the cloud of protective gas just as with argon arc welding. The nozzle is cooled by water flowing along internal channels 5 of the nozzle. The temperature of the arc can be regulated by the form and dimension of the nozzle. Due to the high temperature of the arc and concentration of energy on a small area of contact, with plasma welding the rate of movement of the electrode along the seam is more than that with argon arc welding, and the zone of heating of the metal along the seam is less, which improves the quality of the welding.

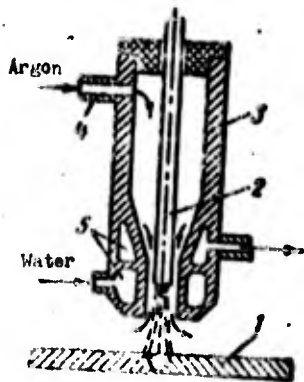

Fig. 5.4. Diagram of plasma welding: 1 - welded parts; 2 - electrodes; 3 - tip; 4 - pipe connection; 5 - channels.

§ 5. Welding by an Electron Beam in a Vacuum

Welding by an electron beam is based on the phenomenon of the liberation of heat with deceleration of an electron beam. In a special apparatus - electron gun, an electron beam is obtained and accelerated to a very high speed. This beam is guided on the welded metal. With an introduction of electrons into the metal deceleration occurs, and the kinetic energy of the electrons turns into heat.

To obtain an electron beam the property of certain substances with heating is used to emit electrons (thermionic emission). Then these electrons accelerate by the action of electrical or magnetic fields. The energy of moving electrons depends on the difference in potentials of the accelerating field. To eliminate a collision of electrons with particles of gases, which with this retard the motion of the electrons, a deep vacuum is necessary.

The necessity to conduct welding in a vacuum complicates the technological process. However, the absence of an atmosphere increases the quality of the welded seam, since the danger of saturation of the molten metal by gases is excluded. Welding is usually produced with the vacuum with a residual pressure of $5 \cdot 10^{-4}$ mm Hg, when the content of gases harmful for welding is only about $10^{-7}\%$ (by volume). This is several thousand times less than that with welding in a protective medium of the purest argon.

A diagram of welding by an electron beam in a vacuum is depicted on Fig. 5.5.

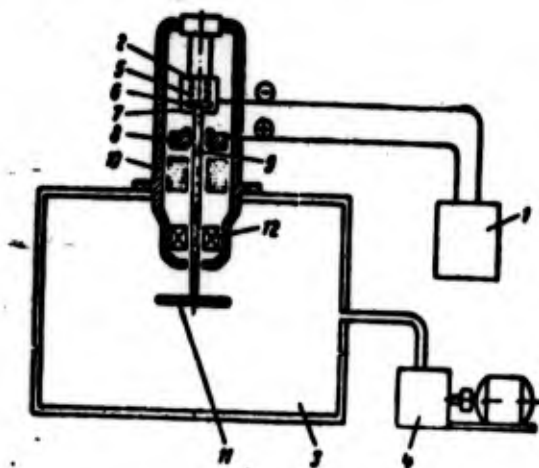

Fig. 5.5. Diagram of electron-beam welding: 1 - rectifier; 2 - electron gun; 3 - vacuum chamber; 4 - vacuum pump; 5 - heater; 6 - cathode; 7 - cathodic electrode; 8 - anode; 9 - electron beam; 10 - magnetic lens; 11 - parts to be welded; 12 - controlling magnetic coils.

The apparatus consists of a rectifier 1, electron gun 2, vacuum chamber 3, and vacuum pump 4. The spiral of resistance 5 under the action of passing electrical current is heated and heats the cathode 6, which at a high temperature starts to emit electrons intensely. Under the action of difference of voltage the electrons rush to anode 8 and further to the welded article, which is also the anode. The form, dimension and mutual location of the cathode and anode create such an electrical field which compresses the electrons into a narrow beam 9 and simultaneously creates acceleration. Further the electron beam passes through a magnetic lens 10, which compresses the electrons into a very narrow beam, which is guided to the welded subassembly 11. Between the magnetic lens and zone of welding it is possible to set a system of magnetic coils 12, with the help of which it is possible to control the electron beam, i.e., to deflect it to any side. Having connected the coils 12 with the system of stored control, it is possible to force ray to describe any figures with a predetermined speed.

This permits conducting welding of subassemblies having complex contours of seams - circle, ellipse. Here the beam deflection from a vertical position practically does not affect the depth and width of the zone of the melted welded seam.

§ 6. Diffusion Welding

Diffusion welding (more correctly, diffusion joining) is based on the ability of molecules and atoms of one substance to penetrate into another substance under the action of the thermal motion of molecules (phenomenon of diffusion).

If the purified parts are tightly connected to each other and they are pressed with a certain pressure, then the molecules of one metal or alloy will penetrate into the other, and upon the expiration of a certain time the connection (joining) of the parts will occur. The diffusion rate depends on the mobility of the molecules, which is increased with a temperature rise in the substance. Aluminum and copper at high pressure are welded due to the diffusion at normal temperature (20°C).

For the diffusion welding of steels and refractory metals and alloys, the heating of parts to a temperature somewhat higher than the temperature of recrystallization of the most fusible of combinable materials is required. However, at such a temperature intense oxidation of steel by oxygen of the atmospheric air occurs and protection from this undesirable phenomenon is required. Therefore, the process diffusion welding is produced in a vacuum at a certain pressure of parts on each other. By this method it is possible to connect not only metals, but also ceramic materials and a combination of metals with ceramics. Diffusion joining is promising method of the connection of materials and is intensively introduced into production.

§ 7. Welding by Light Beam

In the usual natural conditions the density of energy in a light beam is low, and the light does not produce noticeable changes in an illuminated surface. But if the density of the energy is increased, then light beams can melt or vaporize the most refractory substances.

The concentration of light energy for the treatment of materials, welding and other processes is produced with help of maser oscillators - lasers. A diagram of the operation of a laser is shown on Fig. 5.6. From the power supply 1 electrical energy by short pulses (a duration of about 0.001 s) is fed to the low-inertia tube 2, which illuminates ruby rod 3. The ends 4 and 5 of the ruby rod are treated with high cleanness and accuracy and are covered with a layer of silver. With this the layer on the end 5 becomes partially transparent.

With the illumination of the ruby rod certain atoms inside the rod (atoms of chromium) arrive in an excited state and begin to move along the axis of the rod, repeatedly being reflected from the silvered faces. The excitation is amplified with every new flash of the tube,

which gives a pulse of energy, up to a defined level, when discharge occurs through the semitransparent face 5 in the form of a red light beam. This light beam, possessing high concentration of energy, can be focused by lenses 6 into a very thin light beam with enormous density of energy. Under the action of this beam all substances are melted or evaporate.

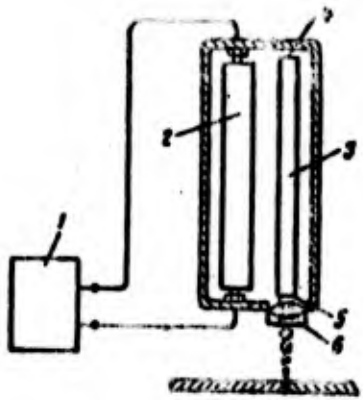

Fig. 5.6. Welding by light beam: 1 - power supply; 2 - tube; 3 - ruby rod; 4, 5 - faces of rod; 6 - lens.

With respect to quality of the welded seam, welding by light beam does not yield to electron-beam welding. A great advantage of welding by light beam consists in the fact that the beam freely passes through the air, and, consequently, there is no need to conduct welding in a vacuum.

§ 8. Preparation of Parts for Welding

Before welding by any of the aforementioned methods, a thorough preparation of the parts for welding is required. Thin-walled parts are welded without dressing of the edges. However, the welded edges must be even, not have burrs, nicks and dents. Special attention should be given to the cleanness of the edges. The presence on the edges of scale, corrosion, oil and other contaminations leads to the appearance in the welded seams of different defects: porosity, slag inclusions, and poor penetrations.

The following forms of purification of the parts are used: sandblast, chemical, ultrasonic.

Sandblast purification is conducted in a special location equipped with good tributary-draw ventilation. Figure 5.7 shows a diagram of sandblast purification. Clean dry sand is filled into the reservoir 1, into which then air under pressure is fed. Air rushes along the hose 2 and entrains the sand. The mixture of air and sand at high speed emerges from the nozzle 5 of head 4 and is guided to part 7 to be cleaned. The process of purification occurs in a special chamber 3, which is connected with a ventilation pipeline 6. The processed sand through grid 8 and trough 9 enters into the bin 10. Then the processed sand is sifted for the removal of dust and can be used repeatedly.

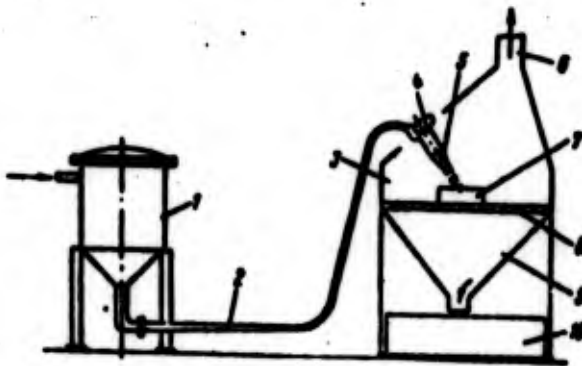

Fig. 5.7. Apparatus for sandblast purification: 1 - reservoir; 2 - flexible hose; 3 - chamber; 4 - head; 5 - nozzle; 6 - ventilation pipeline; 7 - part to be cleaned; 8 - grid; 9 - trough; 10 - bin.

Sandblast purification is a laborious low-productivity operation connected with the formation of a great quantity of dust harmful to the health of people. With ejection by ventilation of the dusted air pollution of air over a large area occurs. The abrasive dust penetrates into the location of workshops and is deposited on equipment, causing intensive wear of friction parts. To catch the dust at the exit of the ventilation system, it is necessary to install complex filters with wet purification.

Chemical purification is more productive as compared to sandblasting and can easily be mechanized. It is produced in following order:

- 1) etching in a solution of acid;
- 2) washing with water;
- 3) neutralization by soda solution;
- 4) washing with water;
- 5) passivation by solution of special preparation for protection from corrosion (for example, 10% solution of the preparation "Mazhef" (manganese ferric phosphate));
- 6) drying with warm air or in special installations.

The composition and concentration of the solutions are selected depending upon properties of metal to be cleaned. All operations with respect to purification are conducted in a special location equipped with baths for solutions, plenum-draw ventilation and means of transport and mechanization of process.

Ultrasonic purification is characterized by the high quality of purification and great productivity. A diagram of ultrasonic purification is depicted on Fig. 5.8. Before ultrasonic purification the parts are degreased with gasoline or white alcohol and dried by blowing with compressed air. Then the parts are subjected to etching in a solution of acid for 15-30 minutes up to full loosening of the scale and are washed with water. For final purification the parts are charged in a bath filled with liquid. Set on the bottom of the bath are exciters of high-frequency oscillations, which are united with a high-frequency oscillator.

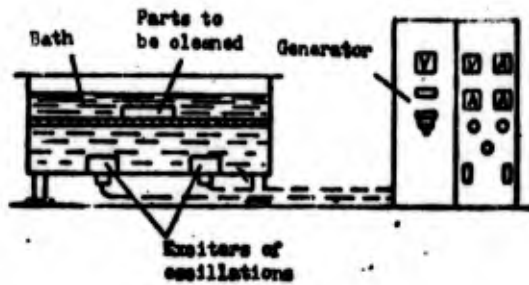

Fig. 5.8. Apparatus for ultrasonic purification.

Exciters of oscillations or radiators are usually magnetostrictive; their operation is based on the use of the magnetostrictive effect - change in dimensions of the ferromagnetic materials under the action of a magnetic field. The radiator has a rod of ferromagnetic material wound with wire. With transmission through the winding of alternating current, the magnetic field will be changed and, consequently, with the same frequency the dimension of the rod will be changed, i.e., it will come into oscillatory motion.

Oscillations of exciters are transmitted to the liquid, into which the parts to be cleaned are immersed. During 3-5 minutes the parts are completely cleaned, and the surface obtains a clean dull color. Then the parts are washed in hot water and dried. Our industry mass produces ultrasonic installations for purification UZA-1, UZA-2, UOG-1 and others.

If time interval between purification and welding is long, and there is a danger of the oxidation of the metal, then the parts after purification are subjected to passivation. In the transportation of the purified parts to the place of welding, it is required to take measures against contamination. It is recommended to use special packing for the transportation. With installation of the parts on devices for welding, one should also take measures against contamination of the parts and especially the welded edges.

§ 9. Equipment for Welding

The necessary equipment for welding is selected depending upon the form of welding used. Figure 5.9 shows a model welding apparatus for automatic welding under a layer of flux, argon arc or plasma. The welded article 1 is secured on the device and is rotated by a manipulator 2. The welding head 3 is fastened to the hopper 4, which moves along guides of the cantilever 5. The feed of the arc is fed along wires 6 through the cabinet of the equipment of control and direction 7 from the feed source 8. The argon is fed through the hose 9. With the welding of annular seams the welding head is stationary, and an article revolves. With welding of longitudinal seams the article is stationary, and the welding head together with the hopper 4 moves along the seam. With welding under a layer of flux, the welding head with bin for flux is set.

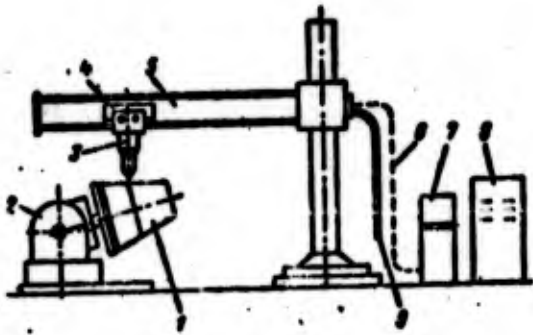

Fig. 5.9. Welding apparatus: 1 - welded article; 2 - manipulator; 3 - welding head; 4 - hopper; 5 - cantilever; 6 - wire; 7 - control equipment; 8 - power supply; 9 - argon supply.

In the selection of power supplies of the arc, one should consider the necessity of providing the stability of its burning. The voltage on the arc depends on the distance between the electrodes and on current intensity. This dependence is called by the volt-ampere characteristic.

With welding by a consumable electrode, the melted metal flows from the electrode by drops, as a result of which the distance between the electrode and welded metal changes, which causes oscillations in voltage and current intensity. Power supplies of the arc have different types of external characteristics: incident, flat-dipping, rigid, increasing. For automatic welding in protective

media one should use power supplies with incident, flat-dipping or rigid external characteristics, which ensure good stability of burning of the arc.

Figure 5.10 gives the volt-ampere characteristic of the arc (BA) incident (Π) and flat dipping ($\Pi\Pi$) characteristics of power supplies.

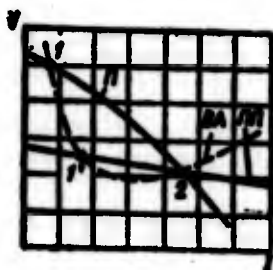

Fig. 5.10. Volt-ampere characteristic of arc (BA) and power supplies.

It is obvious that the voltage on the arc and voltage of terminals of the power supply (neglecting losses in lead wires) are equal to each other, which correspond to points 1-2 or 1'-2 of the crossing of the volt-ampere characteristic and characteristic of the power supply. Let us examine the stability of burning at point 2. If for some reason the current intensity is decreased, then the voltage of the arc appears lower than the voltage of the power source, which leads to a decrease in current intensity, i.e., to a return to the equilibrium point 2. With an increase in current intensity the voltage of the power supply will appear less than the voltage of the arc, in consequence of which the current intensity will decrease and conditions will be restored. Consequently, burning in these conditions will be stable. Conversely, under conditions characterized by point 1, burning of the arc is unstable, since any accidental change in current intensity leads to a break in the arc or transition to point 2.

For welding by a nonconsumable electrode power supplies with incident characteristics are used, and for welding by consumable electrode - with flat dipping characteristics.

The most widespread power supplies - transformers, rectifiers and electrical machines - are converters.

Welding heads are selected depending upon the form of welding. Figure 5.11 shows a welding head for welding by a consumable electrode in a medium of protective gas. It consists of a casing 4, burner 3, guide sleeve 5, changeable tip 2 and nozzle 1. The feed of electrical current to the head is carried out by a wire placed inside a rubber tube, through which passes cooling water during welding. Further the current passes through the casing to the changeable tip and through it to the electrode wire. Inside the casing there are changeable barrels for electrode wire of different diameters. Water for cooling the nozzle proceeds through tube 6 and the protective gas through tube 7.

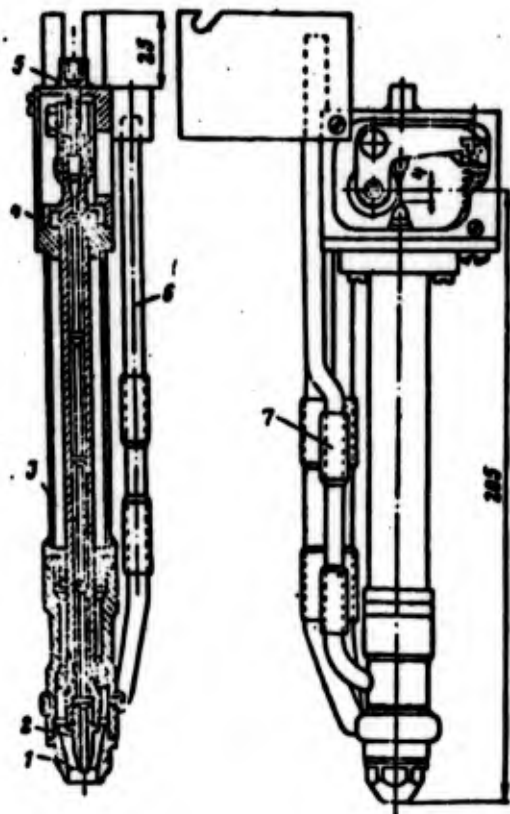

Fig. 5.11. Welding head: 1 - nozzle; 2 - changeable tip; 3 - burner; 4 - casing; 5 - guide sleeve; 6 - tube of cooling feed; 7 - tube of protective gas.

Figure 5.12 gives a cross section of the head for automatic welding to a nonconsumable tungsten electrode. It consists of a tip 1, casing 2, mobile clip 6, and tongs 7. The electrode is pressed in the tongs with the help of the knob 4. A change in the position of the electrode with respect to the nozzle of tip 1 is carried out by knob 5, with the rotation of which clip 6 moves. The protective gas is fed through the pipe connection 3 and through the clearance between clip 6 and casing 2 enters into the nozzle. Clip 6 is cooled by water proceeding through the pipe connection 8. The tongs 7 are changeable and set depending upon diameter of the electrode.

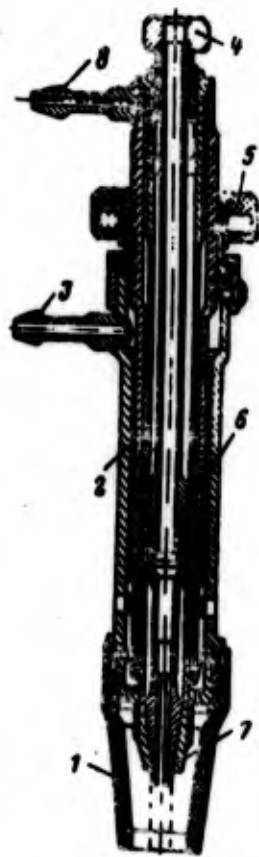

Fig. 5.12. Head for automatic welding to nonconsumable electrode: 1 - tip; 2 - casing; 3 - pipe connection of protective gas feed; 4 - knob of electrode terminal; 5 - knob to change the position of the electrode; 6 - clip; 7 - tongs; 8 - pipe connection of the feed of cooling water.

With the welding of parts or subassemblies, the welding seam should be located horizontally in order to exclude the effect of gravitational forces on the formation of the seam. For installation of parts and subassemblies in the needed position and for their rotation in the welding of annular seams, manipulators are used. The diagram of the manipulator is shown on Fig. 5.13. The welded part (subassembly)

together with the device is secured on face plate 4 of the manipulator. Rotation of the face plate together with the article around the axis is carried out by an electric motor. The slope of the plane of the face plate to an assigned angle is carried out by a turn of the cantilever 3. The number of turns of the face plate is selected depending upon the rate of welding. A change in the number of turns is carried out by replacement of the pinion of the transmission or change in the number of turns of the electric motor.

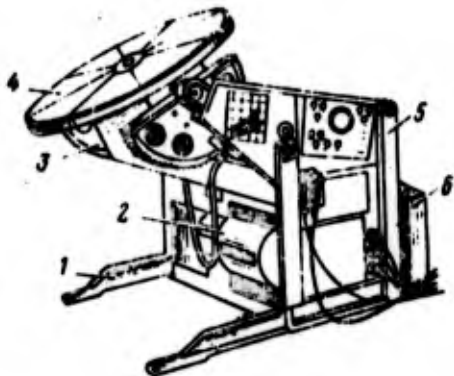

Fig. 5.13. Manipulator for welding works: 1 - bed; 2 - cantilever; 3 - table cantilever; 4 - face plate; 5 - support frame; 6 - electric equipment.

§ 10. Welding of Longitudinal Seams

Longitudinal welded seams can be on parts of the nozzle part, jacket of the central part and in other places of the KS. Longitudinal power seams are presented with very high requirements with respect to strength. From the theory of calculation of cylindrical thin-walled vessels under pressure, it is known that the stress in the material of wall effective in a circumferential direction, is twice larger than the stress effective in an axial direction. Consequently, a longitudinal welded seam of a cylindrical vessel (for example, the jacket of the KS) undergoes stress twice exceeding the stress in an annular seam of the same vessel.

On the other hand, the application of longitudinal welded seams in jackets of the cylindrical part of the KS, nozzle part, rings and in other similar parts is very profitable from a technological and economic point of view, since rolling the flat billets into a cylinder or cone and welding by longitudinal seam are considerably simpler and cheaper than obtaining a cylinder or cone in multitransition

stamps or by rolling. The application of seamless cylindrical thin-walled parts obtained by stamping, rolling or another method is justified only when there is no full confidence in the high strength of the welded longitudinal seam, i.e., if its strength is less than the strength of the basic metal. It is necessary to consider also the vibration strength of the seam, since parts of the KS operate under conditions of vibration.

Let us examine the connection of longitudinal seams by argon arc welding. After giving to parts of the necessary geometric form by flexible or other means, after trimming the edges with assigned allowance by the magnitude of clearance and after purification of edges in accordance with the accepted technology of the part, we proceed to the section of the welding. For retention of the parts in the assigned position, in the process of welding various kinds of devices are used.

A diagram of one of variants of the devices for the welding of longitudinal seams on cylinders and cones is shown on Fig. 5.14. The welded article 1 is set on the cantilever 2 secured on the stand 3. The edges to be welded are pressed by paws 4 turning around axes 5. For this purpose under the second ends of the paws there is a rubber hose 6, into which compressed air is fed. Before clamping the edges of the parts are levelled down to the obtaining of the necessary clearance or are installed without the clearance, as is provided by the technology of welding.

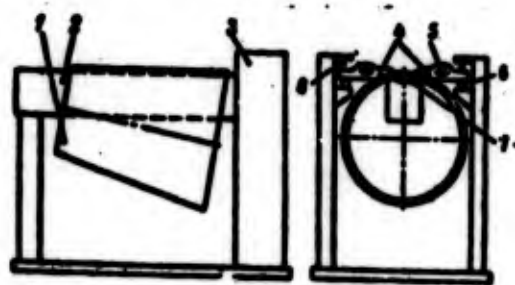

Fig. 5.14. Device for the welding of longitudinal seams: 1 - part to be welded; 2 - cantilever; 3 - stand; 4 - clamp paws; 5 - axis; 6 - rubber hose; 7 - lining; 8 - spring.

To prevent the welding of edges of parts to be welded to the beam 2, there is provided a lining 7 from a material not welded with the material of the parts. In the welding of steels the lining is made from copper. The welding is done automatically. Motion of the welding head along the seam is carried out by movement of the hopper along the cantilever of the welding apparatus (see Fig. 5.9). The device is installed with respect to the axis of the cantilever of the welding apparatus in such a manner that with motion of the hopper along the cantilever the electrode, secured in the head, moves along the middle of the seam or with constant assigned displacement with the welding of parts from metals having various thermal conduction.

After welding the air from hoses 6 is ejected into atmosphere, and clamps under the impact of springs 8 depart from the edges, freeing the article. There are other designs of devices for the welding of longitudinal seams.

§ 11. Welding of Annular Seams

A peculiarity of the welding of annular seams consists in the application of special devices for holding the parts in the process of welding in an assigned position and also in the necessity of rotation of the welded article with a fixed welding head. Before welding the stripping and trimming of edges of the parts to be welded is produced. Here one should maintain in the assigned limits not only the axial clearance Δ_0 between the joined parts, but also achieve the equality of diameters D_{cr} of joinable parts along welded edges (Fig. 5.15). If in the section of the fitting the diameter of one part will be larger or less than the diameter of another part, then there will appear a step Δ_d , which is not always permissible. The device for welding should fix the parts in an assigned position both in axial and radial directions. As an example we will examine the design [2], depicted on Fig. 5.16.

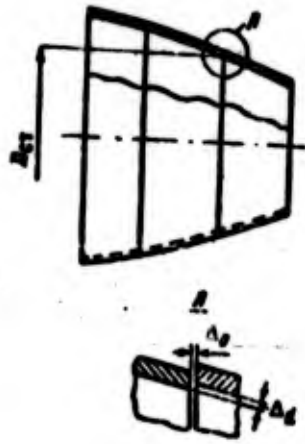

Fig. 5.15. Fitting of edges of parts.

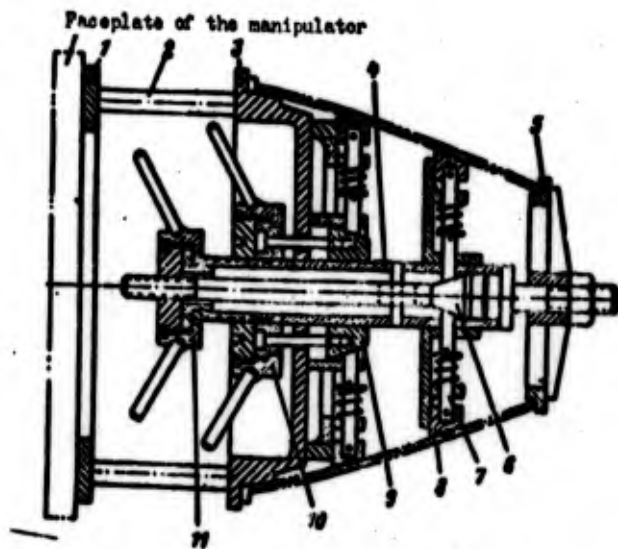

Fig. 5.16. Device for the welding of parts of the KS: 1 - faceplate; 2 - stand; 3 - power ring; 4 - casing of the device; 5 - clamp; 6 - cone; 7 - pusher; 8 - jaw; 9 - cone; 10 - nut of cone 9; 11 - nut of cone 6.

Fastened to the faceplate 1 with the help of tubular stands 2 is the basic power ring 3, which supports the casing 4 of the fitting. The set of welded parts is installed to the stop and held by a clamp 5. In sections where there must be seams, supporting belts of releasing jaws 8 are set. Releasing of the jaws is produced through pushers 7 by movement along the axis of the cone 6. Movement of the cone 6 is carried out by rotation of the nut 11. Releasing of jaws of the second belt is produced by axial movement of the cone 9, carried out by rotation of the nut 10.

With great forces of releasing of the jaws or for the purpose of control of the force of releasing, movement of cones 6 and 9 can be produced by a pneumatic or hydraulic actuator, which is built into the casing of the device. For the realization of the rotation of parts in the process of welding, the device is secured on the faceplate of the manipulator. The slope of the axis of rotation will be selected so that welding occurs with horizontal location of the seam. To avoid the welding of parts to a device, and also to prevent fusions on the jaws of the device, cover plates of material not welded with the metal of the seam are established. With the welding of steel parts the cover plates can be copper.

§ 12. Welding of Collectors

Collectors for feeding liquid coolant and other annular parts are welded with rotation of the article by the manipulator. The slope of the axis of rotation is selected from the condition of correct molding seam. A diagram of the location of the article and welding head is shown on Fig. 5.17.

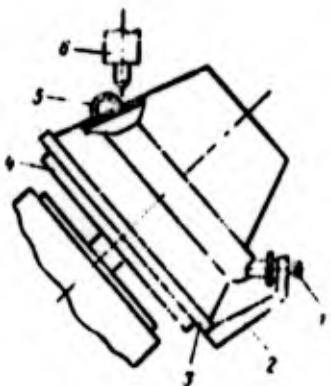

Fig. 5.17. Welding of collectors: 1 - index pin; 2 - bracket; 3 - casing of the device; 4 - faceplate of the manipulator; 5 - welded collector; 6 - welding head.

The device should fix the position of the collector with respect to the jacket of the nozzle both along the axis and with respect to the angle of rotation, since to the collector a pipe with flange is preliminarily welded, and the jacket can also have oriented parts or holes. For orientation of the collector by the angle of turn, there is an index pin 1, held by a bracket 2, secured on the casing 3.

§ 13. Control of Welded Joints

Very high requirements are placed on welded joints of parts of the KS. As a rule, a welded seam should be equal to the strength of the basic metal. Furthermore, the seam should be tight, i.e., should not pass liquid or gas. This is attained by the application of appropriate forms of welding and an exact observance of conditions of welding. With nonobservance these conditions, in a welded seam flaws appear, lowering its strength and tightness. The flaws can be open, revealed by external inspection of the seam, and internal, revealed only by special control means.

Typical flaws of welded joints are the following.

Incomplete regularity of the seam (Fig. 5.18a) is the result of disharmony of the rate of movement of the welding head and magnitude of feed of filler wire. Quantities of molten filler metal are insufficient for filling the space between edges of welded parts. The incomplete regularity of the seam lowers the strength of the connection, since the section along the seam becomes less than the section with respect to the basic metal.

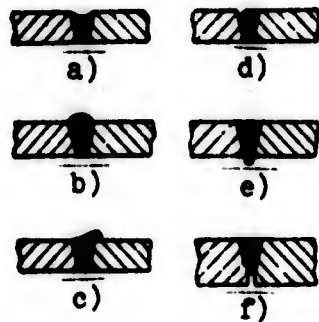

Fig. 5.18. Typical flaws of welded joints.

Overflows of filler metal (Fig. 5.18b, c) are also the result of the disharmony of the rate of movement of the welding head and feed of the filler wire, but in contrast to the defect of the first kind here there is an unnecessary supply of wire and unnecessary

current intensity. Filler metal is melted more than that which is required for the formation of the seam. Overflows do not increase the strength of the seam but serve as concentrators of stresses with alternating or pulsating loads, and therefore they are prohibitive. Overflows can occur with the displacement in one direction due to the slanted (to the horizon) location of the edges. Besides the effect on strength, overflows hinder the connection of the parts, if the connection is carried out along the plane where the seam is located.

Undercuts of edges (Fig. 5.18d) are formed with great slope (to the horizon) of the seam or shift of the center of the electrode from the line of the joint of the parts, with nonuniform distribution of masses or with the disturbance of conditions of welding. The undercuts lower the strength of the seam and are concentrators of stresses.

Fusions (Fig. 5.18e) appear due to the excessive heating of the seam or great clearances between edges of the parts. To avoid the formation of fusions, the welding of thin sheets is conducted on the lining from a material not welded with the metal of the seam (for example, copper lining with the welding of steels). Fusions are frequently combined with the incomplete regularity of the seam.

Poor penetrations (Fig. 5.18f) are formed as a result of the insufficient melting of the metal of the edges, they weaken the strength of the seam and are very dangerous concentrators of stresses with alternating and pulsating loads.

Porosity and slag inclusions appear with the disturbance of the metallurgy of the molten pool, when gases formed in the molten metal (for example, hydrogen) are not able to be separated and congeal in the metal.

Microscopic cracks are the result of heat and shrinkage phenomena and also the action of atomic hydrogen remaining in the pores of metal.

The first four forms of standard flaws can be called external. They are determined with inspection by the naked eye or with the help of magnifier after deburring of the seams. To detect the remaining internal flaws, other improved methods of investigation are required: X-ray, magnetic, chemical, metallographic, ultrasonic and others.

The main problem of technical control consists not in order to reveal a defect in the finished part or subassembly, but in order to prevent the appearance of a defect. This pertains to all branches of production and especially to the production of rocket engines, where the efficiency of the engine and the rocket on the whole depend on every part and where the cost of the parts, as a rule, is high.

Preventive control of the quality of welding is carried out by means of test welding of test specimens and technological subassemblies. Test specimens are welded seams carried out on specimens of the same material as that of the welded parts, on the same equipment and under the same conditions of welding.

Technological subassemblies, sometimes called imitators, are simplified subassemblies of the article intended for the checking of some technological process - in this case the process of welding. The welding of these subassemblies is produced in exactly the same way as and the welding of the main assembly.

Test specimens or technological subassemblies undergo a comprehensive check according to an assigned program of tests. In necessary cases microsections are made and macro- and microanalysis of seams, tensile test, impact strength, angle of bend and other forms of tests are produced.

If the technological process on specimens and imitators gives good results, then the welding of mass-produced subassemblies is allowed. After welding dressing of the seams is conducted (if this is provided by the technological process), and control for the absence of external flaws is conducted. Then control for the absence of internal flaws of welding is conducted.

Let us consider certain methods of the exposure of flaws of welding used. These methods are used also for the exposure of defects in the base metal.

X-Ray Control

The exposure of internal flaws of welding without destruction of the seam by the X-ray method is based on the different absorptivity of X-rays by solid metal and metal in the presence of some flaw.

A diagram of X-ray radioscopy of a welded seam is depicted on Fig. 5.19.

Directed to the welded parts is a flow of X-rays. On the reverse side a film with a layer of emulsion sensitive to X-rays is placed.

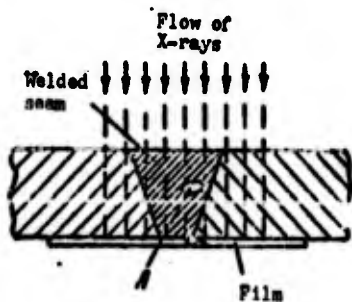

Fig. 5.19. Diagram of X-ray control of a welded seam.

With passage of the rays through the layer of metal, part of them will be absorbed. The magnitude of absorption depends on properties of the material and thickness of the parts and welded seam. If in the welded seam there is some flaw, for example a vacuum A (gas cavity), then at this place the absorption of the rays will be less, which will be reflected on the film in the form of a spot with stronger irradiation. After development of the film at this place there will be a dark spot, corresponding with respect to the dimensions to the projection of the cavity on the plane of the film. Some inclusion more dense than that of the base metal will form a light spot on the film.

The source of the X-rays is an X-ray tube, which is schematically depicted on Fig. 5.20. In glass envelope there is an anode, which is made in the form of a plate of tungsten or tantalum, and a cathode. Inputs to an anode and cathode are hermetically sealed, and from the envelope air is removed. The tube is connected to a power supply of high-voltage direct current: the anode is connected to the positive pole, the cathode - negative pole. The filament of the cathode is heated and starts to radiate electrons, which under the action of the electrical field of high voltage rush to an anode. As a result of the electron bombardment of the surface of the anode X-rays are generated, which through an opening rush to object of irradiation. For the feeding of the tube with high-voltage direct current, a transformer, rectifier, and regulating equipment are needed. Furthermore, a special device for the installation of the tube in a needed position is necessary. All of this enters into the assembly of the X-ray apparatus, manufactured by industry.

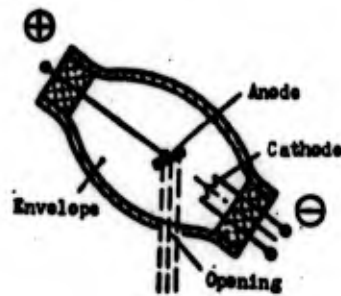

Fig. 5.20. X-ray tube.

When working with an X-ray apparatus one should consider the harmful action of X-rays on the organism of the person. Therefore, appropriate measures of protection are taken: radioscopy is produced in a specially equipped protected location, and the control of the apparatus and turn of the article (if it is required) are produced remotely, etc. By X-ray radioscopy it is possible to reveal only defects of a defined magnitude in accordance with the resolving power of the screen or film. Sometimes the difference in absorption of rays with the passage of unimpaired and damaged sections of the part or seam is so small that on film it is practically impossible to note defects. With a normal X-ray photograph the flaws less than 0.3-0.5 mm are almost indiscernible. Stratification located perpendicular to the direction of rays is not revealed by X-ray radioscopy.

Identification of the character of flaws of welding by X-rays (are thus called developed and treated films) is a sufficiently difficult matter and requires great skill. For the interpretation of X-ray photographs, standard X-ray photographs obtained with the radioscopy of specimens with known defects are used.

With the help of an X-ray apparatus it is possible not only to obtain photographs on film, but also to observe the formation of the welded seam directly in the process of welding, projecting the image on the screen, as it is done in medical practice. Thus it is possible to control the technological process of welding, achieving high quality. Here one should consider that for the radioscopy of metallic parts more hard rays are used than in the radioscopy of living organisms, and hard rays are harmful to man. Therefore observation with radioscopy of parts should be produced remotely with the help of television. To improve the sharpness of the image an electronic amplifier of brightness, founded on the property of a photoelectrical layer can be used to convert the flow of X-rays into an electron beam with an intensity considerably greater than the flow of the X-rays. By this method it is possible to increase the sharpness of the image several tens and hundreds of times.

Ultrasonic Control

The exposure of defects with the help of ultrasonics (i.e., sound higher than the threshold of audibility by man equal to 20 kHz) in many cases is more effective than with the help of X-rays. Ultrasonic oscillations are propagated differently in various media. In certain cases they are almost completely reflected from the encountered obstacle. In particular, ultrasonics is reflected from the boundary of two media. These properties of ultrasonics are used in the exposure of internal defects in metals.

The most important element of any instrument for ultrasonic control is a crystal possessing piezoelectric effect. The essence of this phenomenon consists in the following. If a quartz crystal is subjected to compression or extension, then on the edges of this

crystal electrical charges will be formed: with compression a charge of one sign will be formed and with extension -- another. On the other hand, with the application to edges of the crystal of variable voltage the crystal is deformed -- it oscillates into the cycle of the alternation of the sign of the electrical charge. Such a property is possessed also by crystals of barium titanate and certain others. The piezoelectric effect for barium titanate is greater than that for quartz, and the obtaining of plates from crystals of barium titanate is simpler and cheaper. But these plates can operate only at a temperature of less than 120°C. A quartz plate operates well at temperatures of several hundreds of degrees. Consequently, if to such a plate a voltage of high frequency is passed, it will arrive in an oscillatory motion into the cycle of this frequency and will radiate sound waves. It is possible also to use magnetostrictive converters, operation of which was examined by us earlier in § 8 of this chapter. By using the property of certain media to reflect ultrasonic waves, it is possible to focus them into a narrow directed beam.

If on the path of this flow of ultrasonics another piezoelectric plate is set, then it will receive the ultrasonics and will come into oscillatory motion. The latter will be converted into electrical charges on edges of the crystal, which can be measured by an instrument.

A diagram of ultrasonic control is depicted on Fig. 5.21. From the electrical high-frequency generator 1 alternating voltage is transmitted to a piezoelectric plate 2, which radiates ultrasonic waves. The plate is tightly pressed to the surface of the part subjected to control. Oscillations of the plate are transmitted to the part 3 and further to the receiving plate 4. If in the part there is an internal defect A, then ultrasonics will be reflected from the boundary of the media and after the defect "shadow" will be formed -- which will be absorbed by the receiving piezoelectrical plate 4. The magnitude of the voltage on edges of the crystal of plate 4 is very small, and therefore between the indicating instrument 6 and plate 4 an amplifier 5 is set.

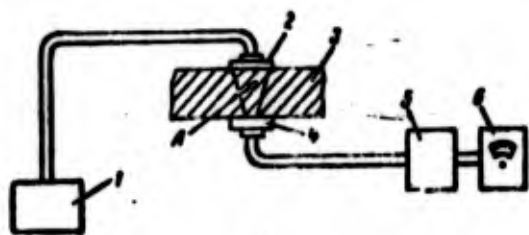

Fig. 5.21. Diagram of ultrasonic control: 1 - high-frequency oscillator; 2 - piezoelectric radiating plate; 3 - controlled part; 4 - receiving plate; 5 - amplifier; 6 - indicating instrument.

A deficiency of this "shadow" method of ultrasonic control is that it is necessary to set the radiating and receiving plate on two sides, which is not always possible or is inconvenient. This deficiency is eliminated in instruments with the catching of the reflected ultrasonic signal. A diagram of control with the help of the reflected ultrasonic signal is depicted on Fig. 5.22. From the high-frequency oscillator to the piezoelectric radiating plate 1 short pulse (duration, 3-5 microseconds) is fed. Ultrasonic oscillations propagate in the metal of the investigated part 2, are reflected from boundary 4 and are absorbed by plate 3. Moments of the feed of the signal and reception of the reflected signal are recorded on an electron-beam tube 5 (electrical circuit of the instrument is not shown), where burst 6 shows the initial pulse, and burst 8 - the reception of the reflected pulse - is called the bottom pulse (reflected from the "bottom" of the part, i.e., boundary 4).

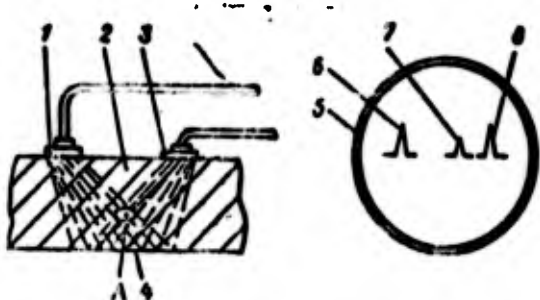

Fig. 5.22. Diagram of ultrasonic control by the reflected signal: 1 - radiator; 2 - investigated part; 3 - receiving plate; 4 - interface; 5 - electron-beam tube; 6 - initial pulse; 7 - defect pulse; 8 - bottom pulse.

If on the path of ultrasonic waves there is encountered a defect A, then from it part of the waves will be reflected and these reflected waves will arrive at the receiving plate earlier than that of the bottom pulse and will give burst 7. With respect to the distance between the burst the depth of occurrence of the defect can be found. In certain ultrasonic flaw detectors of pulse action, one and not two plates is used.

At the time of the feed of the initial pulse the plate serves as a radiator and then collects the reflected pulses and transmits them into the amplifier.

The ultrasonic method of control has become widespread. Certain defects not revealed by the X-ray method are easily revealed by ultrasonic instruments. In particular, laminations and cracks in metal perpendicular to the direction of X-rays are not recorded on the X-ray photograph. With the help of ultrasonics these laminations and cracks are easily revealed, since they are interfaces of the media.

Ferromagnetic Control Method

It is possible to reveal by the ferromagnetic method very small surface cracks and other defects which are not revealed by the X-ray or ultrasonic method. The ferromagnetic control method is based on the orientation of ferromagnetic powder along the flow of magnetic lines. In the investigated section of the metal a magnetic field is created with the help of an electromagnet (poles of the electromagnet are closed). If on the surface of the part there is put ferromagnetic powder, then it will be disposed along magnetic lines from one pole to the other with a certain accumulation of the powder near the poles, the giving figure of the magnetic field, as is shown on Fig. 5.23.

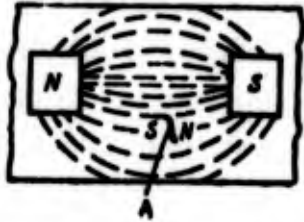

Fig. 5.23. Ferromagnetic method of the detection of surface cracks.

In the presence of crack A in the metal, the magnetic field near the crack will change its structure: on borders of the crack new magnetic pole N and S will be formed, as is observed in any magnet, if it is broken into parts. Under the action of the formed poles near borders of the crack an accumulation of ferromagnetic powder will be formed, i.e., a defect in the metal is revealed. For creation of a magnetic field stationary and portable electromagnet are used. As the ferromagnetic powder magnetite, obtained as a result of the special treatment of oxide of iron (red lead) is usually used. The powder is used both in dry form and in the form of a suspension, i.e., mixtures of powder with a liquid - oil, kerosene, water or other liquid.

The sensitivity of the ferromagnetic method depends on the magnetic field strength, the quality of powder or suspension, depth of occurrence and form of the defect. The brightest are surface defects on smooth clean surfaces. By this method it is possible to reveal not only the evident defects, but also the heterogeneity of structure of the metal, cold hardening in the metal and other heterogeneities. This should be considered in order not to take deflections of the figure of the powder ("false defects") as defects in the metal.

The deficiency of the ferromagnetic method consists in the fact that it is useful only for the control of parts made of magnetic materials.

Luminescent Control Method

The luminescent control method is used for the detection of surface defects. On surface subject to control there is applied a layer of luminescent substance (luminophor), which penetrates into cracks and other defects of the material. Upon the expiration of a certain time the applied layer departs from the surface, and in cavities of the defects the luminescent substance remains. Then in the shaded location to the surface invisible ultraviolet rays are directed, under the action of which the luminophor, which occurs in cracks and other defects, starts to gleam the visible light, i.e., defects are revealed. There are many luminescent substances, but for control liquid substances possessing good penetrability in small cracks are used. Very good penetrating ability is possessed by kerosene, into which mineral oil is added for increasing the luminous intensity. Industry manufactures special luminescent compositions for purposes of flaw defection (defectol noriol [Translator's note: these are not verified] and others).

The luminescent substances used should be inert with respect to the material of the test part, i.e., they should not enter into chemical reaction with the material of the part. The sensitivity of the luminescent control method is very high. With its help it is possible to reveal the smallest cracks and other defects. The method can be used for any materials.

A deficiency of this method is that in the observation of the defects it is necessary to work in a dark location or establish local shading of the test part.

Method of Dyes

The method of dyes, or dye penetrant method, consists in the fact that on the test surface there is applied a layer of colored liquid, which penetrates well into cracks, for example, kerosene with a small addition of bright paint (for example, Sudan-3). Then the surface is wiped dry, and a thin layer of kaolin (white powder)

is applied. The liquid remaining in the cracks is absorbed by the kaolin and colors it a red color, revealing hidden defects.

The resolving power of this method is high: surface cracks with a width of up to 0.01 mm and depth of not less than 0.03-0.05 mm are revealed well.

The colored figure appears quite brightly, and for detection of the defects shading is not required, as this is done with the luminescent method. The method of dyes has become widespread.

Metallographic Investigations

Besides control without destruction of the seams, metallographic investigations of the quality of welded seams are also conducted. For these purposes a cut of the samples or selective subassemblies and thorough deburring of places of the cuts are produced, i.e., microsections for analysis are prepared.

Then micro- and macroanalysis of zones of welding -- fused metal and adjacent sections of the base metal is produced. Methods of analysis are standard, i.e., etching by an appropriate reagent for exposure of the structure and different defects. With small magnification (up to $\times 20$) border of the welded seam, structure of the metal and all flaws of large dimensions are revealed.

With magnification from $\times 50$ to $\times 150$ microscopic cracks, micropore, magnitude of the grain, separation of carbides and others are revealed.

CHAPTER 6

BRAZING OF SUBASSEMBLIES OF THE COMBUSTION CHAMBER

§ 1. Basic Requirements

The brazing of subassemblies of the combustion chamber is a very important part of the technological process of its manufacture. Brazed connections are required to have high strength and airtightness with operation in stressed thermal conditions and in the presence of vibrations of the parts. Therefore with the brazing of subassemblies of the KS are used the most perfected methods of brazing and best solders.

Brazing is called the process of the connection of metallic parts in a heated state at which the clearance between them is filled with low-melting metal or alloy called by solder, which fastens the parts upon their cooling. For connection by brazing it is necessary that the parts are well fitted to each other and that the liquid solder moistens well the combinable surfaces and ensures good adhesion.

In the process of brazing complex physicochemical phenomena occur. The most essential condition of brazing is the interaction of the solder with metals of combinable surfaces, which provides the spreading of liquid solder and filling of the clearances between the parts. The spreading of solder over the surface depends on the surface tension of the solder in a liquid state and on molecular forces on the moistened surface. If the attractive force between molecules

of the solder and molecules on the surface of the metal to be soldered will be greater than forces of the surface tension of the molten solder, then spreading of the solder over the surface, i.e., wetting of the surface will occur. In practice wettability is estimated by the contact angle θ (Fig. 6.1) formed between the plane of wetting and straight line drawn from the boundary between the surface and solder tangent to the surface of the drop of liquid solder (Fig. 6.1a and b). Good wetting and spreading over the surface is shown on Fig. 6.1d (contact angle $\theta \approx 0$). On Fig. 6.1c the solder does not entirely moisten the surface ($\theta = 180^\circ$).

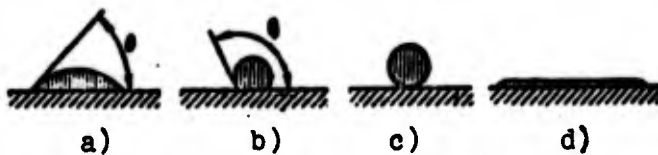

Fig. 6.1. Wetting of the surface by solder.

Wettability very greatly depends on the cleanness of the moistened surface. If on the surface there are contaminations or oxides, then the solder will not interact with the metal of the surface. Therefore, it is necessary to prepare thoroughly the surface for brazing (dressing, degreasing). Furthermore, in the process of the heating of parts for brazing on surfaces oxides will be formed fast. To prevent oxidation of the surface, heating and brazing are conducted in a vacuum, in a protective atmosphere or with fluxes dissolving the oxides and preventing further oxidation. Clearances between the combinable surfaces are of great importance. The most favorable (optimum) clearances are found practically taking into account properties of materials of the combinable parts, brand of the solder, method of brazing, structures of parts and other factors.

The flowing of the solder in clearances between the parts depends not only on the wettability and magnitude of the clearances, but also on the location of the combinable surfaces with respect to the horizon. With the horizontal location of the surfaces, the distance

to which the solder spreads into the clearance depends on properties of the solder, magnitude of the clearance and time of exposure. With vertical location of surfaces, the magnitude of lifting of the solder in the clearance, furthermore, is affected by the action of the weight of that column of solder on which it rises in the clearance. Solder can rise only to a definite height, determined by the condition of equilibrium of capillary forces and weight of the column of liquid solder. The time of exposure affects the magnitude of lifting of the solder only in the initial 1-10 minutes. Subsequently, equilibrium advances, and the solder does not rise higher.

Such a character of the filling of clearances determines basic requirements for the location of the solder with the assembly of the parts and for the position of parts during brazing. With the brazing of long seams with a large combinable surface the solder for best spreading should be disposed not in one place, but evenly over the entire surface of the joint in the form of foil or by applying the solder on the surface by spraying or the galvanic method. With the brazing of parts which are connected by both horizontal and vertical long seams or parts having a more complex combination of seams, for the best spreading of the solder a slow turning of parts in the process of brazing is recommended.

§ 2. Solders

The selection of a certain solder depends on many factors: combinable metals, methods of brazing, design of the subassembly, and requirements of strength, airtightness, corrosion resistance. There are sufficiently many brands of different solders proved in practice and recommended in certain constructions. However, there are certain general basic requirements for solders.

1. The solder should provide the strength and tightness of the connection assigned by the design of the subassembly. The solder itself cannot possess high strength, but in the process of mutual diffusion with the combinable metals it should form the alloy of needed quality.

2. The melting point of the solder should be lower than that temperature at which the combinable parts start to lose their form, i.e., to be melted or greatly be deformed due to softening.

3. The solder should possess good wettability of combinable surfaces and penetrate well into small clearances.

4. The solder should satisfy requirements of the technology of its application on combinable surfaces by the method of spraying, galvanic method or other. If the solder is used in the form of thin tapes or sheets (foil), then such solder should possess good plasticity for the manufacture of the foil and its stacking on surfaces to be soldered.

5. The soldered seam should satisfy technical requirements placed on the subassembly with respect to corrosion resistance, acid resistance, thermal stability, etc.

6. Coefficients of thermal expansion of the solder and combinable metals should be similar.

Solders are divided into low temperature -- which melt at a relatively low temperature, and high-temperature -- which melt at high temperature.

For the brazing of parts of the KS brazing alloys silver, copper, nickel and others are used.

Silver Solders

Silver solders have become widespread for brazing of parts from stainless steels. They provide high strength of the connections and possess good wettability.

For example, solders of brands PSr25, PSr40 and PSr45 (All Union Government Standard 8190-56) in the soldering of parts of steel 1Kh18N9T ensure the obtaining of the strength of $250-350 \text{ MN/m}^2$ ($25-35 \text{ kgf/mm}^2$).

The solder PSr85 is used for the brazing of stainless steels in neutral gases (argon, helium) and heat-resistant alloys in a media with gaseous flux. This solder cannot be used with brazing in a vacuum or for obtaining vacuum-tight connections due to the slight evaporation of manganese.

Silver solders possess good plasticity and can be subjected to hot and cold rolling and drawing for obtaining foil, rods, sheets, tapes of wire, etc.

Copper Solders

To obtain highly durable connections by the method of brazing both pure copper and alloys of copper with other metals are used. Pure copper with the brazing of steels in furnaces with a gaseous environment flows well into clearances and ensures high strength and plasticity of the seam. A connection in the seam will be formed due to the dissolution of copper in iron and penetration of copper on borders of the grains. A deficiency of brazing with copper is a high temperature of brazing of 1150-1200°C, at which a noticeable growth in the grain of the steel and impairment of its mechanical qualities occur.

With the brazing of steels and alloys with a large content of nickel the copper solder starts to diffuse into the alloy even before the beginning of fusion of the solder and in the melted state will form a new alloy, which badly spreads and fills the clearances. Therefore, it is possible to solder by copper only with rapid heating in order to prevent diffusion, for example, in heating by currents of high frequency.

Lowerings of the temperature of brazing down to 850-905°C can be achieved as a result of the addition of zinc in the copper. Such alloys are called copper-zinc solders. They possess good fluidity and plasticity.

A deficiency of copper-zinc solders is that their strength depends on the temperature. At normal temperature their strength is considerably higher than that of copper. At a temperature of higher than 400°C the strength of these solders sharply drops.

With brazing by copper-zinc solders of parts of stainless steel of the type 1Kh18N9T cracks will be formed, in consequence of which for the brazing of such steels these solders are not recommended.

Heat-Resistant Solders

Silver and copper solders do not ensure the needed strength at high temperature. For the brazing of parts operating at temperatures higher than 500°C, solders with nickel or noble metals as bases are used.

Of Soviet heat-resistant solders it is possible to name these solders [6]: P77 - melting point, 1200-1250°C, P77-1 melting point 1100-1150°C, No. 22 - melting point, 1100°C and No. 27 - melting point, 1150°C. Connections brazed by these solders can operate for a long time at a temperature of 800-850°C and not lose their strength. The strength of seams brazed by these solders, depending upon the brand of the base metal, varies from 94 to 217 MN/m².

Solders for the Brazing of Titanium Alloys

For the brazing of titanium and its alloys, it is possible to use silver solders PSr40 and PSr45, pure silver and an alloy of silver (85%) and manganese (15%).

With brazing in a medium of argon with pure silver a connection with a tensile strength of about 190 MN/m² is obtained, and with silver-manganous solder - up to 250 MN/m². Silver-manganous solder can also be used for the brazing of titanium with stainless steel. The connections are durable (resistance to the cut of up to 250 MN/m². if the surface of titanium is preliminarily covered with silver.

§ 3. Fluxes

The connection of parts by solder occurs only when the surfaces are cleaned from oxides and other films. To remove the oxide films and prepare the surface for the wetting of it by solder, fluxes protective or reducing gas media or solder in a vacuum are used.

Fluxes can be both hard and gaseous. Let us consider the behavior of hard flux and solder with heating on the surface of a metal. On Fig. 6.2a on the surface of a metal pieces of flux and solder are placed.

After the achievement of the melting point of the flux, it will moisten the surface of the metal and spread over it, interact with oxides formed on the surface of the metal, and remove them, thereby cleaning the surface (Fig. 6.2b). The moment of melting of flux (Fig. 6.2c) the surface of the metal will be prepared for the molecular interaction with the solder, and it will spread evenly over the surface (Fig. 6.2d). Analogous phenomena occur with the flowing of flux and solder into the clearances.

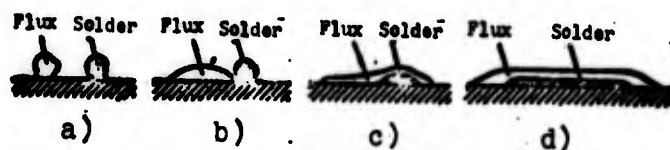

Fig. 6.2. Spreading of flux and solder over the surface.

Hence there results the following basic requirements for fluxes:

1. The melting point of the flux should be lower than the melting point of the solder.
2. The flux should moisten well combinable surfaces of metal and flow into clearances between these surfaces.

3. At a temperature somewhat lower than the melting point of solder, the flux should remove from the surface of the combinable parts and from the surface of the solder all oxides not separating the harmful poisonous gases and those not entering into chemical reaction with the solder or with the metal of the combinable surfaces.

4. In the process of brazing the flux should protect from oxidation surfaces of the metal and solder, promoting the best flowing of the solder into the clearances.

5. The density of the flux should be less than the density of the solder in order to prevent its mixing with the solder.

6. Residues of flux after brazing should depart easily.

With the brazing of stainless steels and heat-resistant alloys, on the surfaces upon heating stable oxides will be formed. To remove them highly active fluxes are required. Composition of such fluxes includes boric acid, potassium fluoride, borax and other components.

§ 4. Gas Media and Vacuum

Gaseous media used in brazing can be reducing and protective. Hydrogen, dissociated ammonia and certain combustible gases are used as reducing gases. The assignment of these gases is to reduce the oxides forming on surfaces subject to brazing in the process of heating.

The formation of oxides on surfaces of the metal with heating in a reducing or inert medium occurs due to the presence of small quantities of oxygen and vapors of water. Those components in steel or an alloy which are better connected with oxygen oxidize faster. These elements start to diffuse toward the surface and intensely begin to be oxidized, forming an oxide film. As a result of this, in the surface layer of metal it becomes less than these components, which changes the properties of steel. For example, with the heating of stainless steel 1Kh18N9T, oxidizing the fastest of all is chromium,

as a result of which the surface of the steel is impoverished of chromium up to 8-10%, which leads to a sharp lowering of corrosion resistance of this steel. Hence there results the requirement for cleanness of the medium at which brazing occurs, and the oxygen separated with dissociation can be connected with the reducer.

Process hydrogen, which contains up to 0.5% oxygen and up to 25 g/m³ of moisture, is not useful for brazing and requires thorough purification. The degree of gas scrubbing from water vapors are determined according to the dew point, i.e., the temperature at which water vapors are condensed. For the brazing of stainless steels and heat-resistant alloys, it is necessary that the dew point be lower than -75°C.

The purification of gases from moisture and oxygen is produced in special drying installations.

For the purification from moisture the gas is passed through vessels - adsorbers filled with silica gel and alumogel. The latter quickly absorb (adsorb) the water vapor. The silica gel provides drying of the gas up to a point of dew of -40 to -50°C, and alumogel from -60 to -70°C.

For the purification from oxygen the gas is heated up to 700-800°C and is passed through a special chamber filled with copper shavings, which is oxidized and absorbs the oxygen.

With use of hydrogen as a reducing medium, it is necessary to observe strictly the rules of safety engineering. Hydrogen in a mixture with air in a large interval of percentage will form a thundering mixture, which easily explodes. If in a furnace where brazing is conducted air accidentally enters, then the explosion can occur. Therefore, more rational is the application of nitrogen-hydrogen mixture, which is cheaper than hydrogen and with a content of hydrogen of 7 to 20% does not explode. Such a medium is obtained by means of the mixing of hydrogen and nitrogen or by means of the dissociation of ammonia.

Dissociation - the process of splitting molecules of ammonia on molecules of hydrogen and nitrogen - is conducted in dissociator (cracker) at a temperature of 600-700°C in presence of the catalyst (iron oxides). The split gas contains 75% hydrogen and 25% nitrogen (by volume) and is dangerously explosive. For the purpose of decreasing the concentration of hydrogen into the mixture nitrogen is added, or partial burning of dissociated ammonia in air is conducted. With the burning of the dissociated ammonia a large quantity of water will be formed, which departs in special coolers and an adsorber with the silica gel or alumogel.

Inert Gases

With high-temperature brazing, as inert protective gases pure argon or helium are used. Before using them they pass purification so that the dew point is not higher than -70°C. The remaining small impurities of oxygen and water upon heating lead to a certain oxidation of the surface of the metal. But with a further increase in temperature the surface is cleaned, since the oxides formed are decomposed, separating the free oxygen. With the decomposition of oxides a certain increase in partial pressure of the oxygen in the gas occurs. To decrease the partial pressure of oxygen in the gas, there is performed a gradual blowing of the furnace or container where is conducted the brazing, so that the gas enriched by the oxygen is displaced by new portions of purified gas. Brazing in a protective gas is conducted without flux, the articles are obtained with a pure surface, and, consequently, the operation on the purification and removal of flux drops out. The quality of the brazed connections is high.

The main deficiency is the high cost of the process, since argon and helium are expensive gases.

Brazing in a Vacuum

A very high quality of connection is obtained with brazing in a deep vacuum, when the pressure of air remaining in furnace or in container is less than 10^{-2} to 10^{-5} mm Hg. With such rarefaction the quantity of oxygen is very insignificant, and oxidation of the surface almost does not occur. The deeper the vacuum, the less the partial pressure of the oxygen and, consequently, the less the conditions are for the formation of an oxide film on the surface of the metal. Thin oxide films, which exist on the surface of the metal up to the charging into the container for brazing, upon heating under the action of the temperature are decomposed, and the separate oxygen and other gases are constantly drawn off by a vacuum pump. Furthermore, certain oxides even prior to decomposition evaporate under the action of temperature and deep vacuum and are also drawn off outside. Certain components of alloys, for example, zinc, cadmium and boron, evaporate so rapidly that with a large concentration of them in the solder the boiling of the solder with energetic separation of the vapors occurs.

In order that the separated vapors of metals do not obstruct the vacuum pumps, the condensing chamber (cooling vapors up to a temperature of their condensation) and filters are installed.

Vacuum pumps will be selected proceeding from the necessary depth of rarefaction. To create a vacuum up to 10^{-2} mm Hg piston pumps VN-1, VN-2, VN-3 and RVN-20 are used. For a deeper vacuum high-vacuum diffusion pumps of the type N-2T and N-5S are connected additionally to these pumps.

The quality of brazing in a vacuum in many respects depends on the speed of inleakage of atmospheric air in the leakiness of the main lines and on the degree of separation by walls of the container, devices and the actual article of earlier adsorbed gases. The degree of inleakage of air and gases is estimated by the change in vacuum over a definite time with a disconnected vacuum pump. The process of brazing in a vacuum complex is expensive. But it ensures the obtaining of soldered connections of increased strength.

§ 5. Equipment for Brazing

Articles for brazing are usually heated in special electrical furnaces. When brazing with the application of fluxes in a furnace the atmospheric air is heated. When brazing in a medium of protective gases, protective gas taken by a technological process with low excess pressure is fed into the furnace. When brazing in a vacuum the furnace is hermetically sealed, and air is pumped from the working space up to the necessary rarefaction.

Dimensions and design of furnaces are determined by dimensions of the soldered subassembly and devices for the fastening of subassemblies in the process of brazing. Figure 6.3 shows a diagram of a chamber electrical furnace. It consists of a metallic casing 5, covered inside with a lining 8 of fireproof material. The casing is set on carriage 10 moving on rails 9. The soldered article 6 is supported by a loading device 2. The furnace is closed with a cover 4 with packing 3. Heating is carried out by electric heater elements 7. Control of the operation of the furnace is conducted by special control and measuring equipment placed in cabinet 1. The feeding of the furnace by inert gas is carried out through the device 11. With vacuum brazing instead of device 11 vacuum pumps are established. For installation of the soldered subassembly onto the loading device the furnace is rolled away, as is shown on the right by the dashed line, and then it approaches to the loading device and is hermetically sealed by the cover 4.

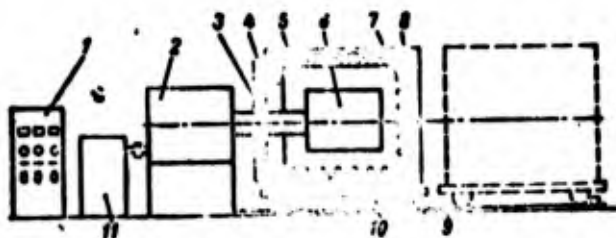

Fig. 6.3. Diagram of brazing in a chamber furnace: 1 - cabinet of measuring equipment; 2 - loading device; 3 - packing; 4 - cover; 5 - casing; 6 - article to be brazed; 7 - heating elements; 8 - lining; 9 - rails; 10 - carriage; 11 - supply system of inert gas or the creation of vacuum.

Loading can be carried out by another scheme: with a fixed furnace and mobile loading device. When brazing subassemblies of the KS in form of solids of revolution - central part of the KS and nozzle - there is the danger of solder flowing into the lower part under the action of gravitational forces. Therefore, for the purpose of ensuring equal distribution of the solder in the process of brazing the subassembly is turned around its axis.

A serious deficiency of brazing in furnaces is the difficulty in achievement of a good hermetic sealing of joints. Even with little leakiness the suction of air into the furnace and, consequently, contamination of the medium surrounding the brazed article by oxygen, water vapors and other gases occur. Furthermore, with an open furnace during loading the air and other gases penetrate into pores of the lining, are adsorbed (are absorbed) by the metal of the heaters, devices and other parts of the furnace. After the shutting of the furnace and increase in temperature these gases and the air are separated, contaminating the medium and worsening conditions of brazing. Even small impurities of oxygen and other gases entering into reaction with the metal of the soldered parts considerably lower the quality of the brazing. Therefore, frequently high-quality brazing is produced in hermetic containers placed in any electric furnaces [3].

Containers are welded from heat-resistant sheet materials. At temperatures of up to 1250°C steel and alloys of brands 1Kh18N9T, EI435, EI602, and EI654 are used. The form of the container is selected proceeding from the possibility of a convenient location in it of the subassembly to be brazed with minimum volume of the container. The cover of the container is fastened by bolts or other split connections or is welded. With brazing in a medium of inert gas into cover or into casing of the container three tubes are welded: one for the feeding of the inert gas, a second for the exit of the inert gas and a third for the input of thermocouples for the measurement of the temperature of brazing. At a temperature of brazing of up to 1000°C Chromel-Alumel thermocouples are used. At a higher

temperature, up to 1300°C, use platinum platinumrhodium thermocouples. Heating elements in furnaces with temperature of heating of up to 1150°C are made of Nichrome alloys, and at a temperature of up to 1300°C Silit or carborundum elements are used. For very high temperatures heating elements are made of molybdenum (up to 1700°C) or tungsten (up to 2500°C) with protection of them from oxidation by inert gas or a vacuum.

The temperature control in the furnace is produced continuously by self-recording instruments. With an increase or lowering of the rated temperature in the furnace the instrument gives command on switching on or turning off the feeding of the heating elements. Both the heating elements and a certain part of them - for a more accurate regulation of temperature can be switched on or disconnected.

For the feeding of the furnace or container with inert gas a special place for installation of cylinders with gas is equipped. Gas enters into the furnace or container along a pipeline through reduction valve which lowers the pressure down to the rated value and maintains this pressure constant for the whole period of brazing independently of the pressure drop in the container. To measure the quantity of inert gas flowing through the container or furnace, at outlet a gas rotameter is installed. The control of the degree of contamination of the gaseous environment can be produced by gas analyzer installed on the outlet gas main line from the furnace or container. With brazing in a vacuum near the furnace vacuum pumps are set: mechanical - for preliminary (initial vacuum) pumping out of the air, and diffusion - for the creation of a deep vacuum. Types of pumps, pipelines, closing fittings and instruments used for measurement of the depth of vacuum are the same as those used in welding in a vacuum.

An essential deficiency of brazing in a vacuum in standard furnaces is a slow heating and cooling of the article to be soldered due to poor thermal conduction in the vacuum. This decreases the productivity of the furnaces and leads to a growth in grains of certain steels and alloys, which lowers their mechanical properties.

With brazing in containers conditions of the transmission of heat from heating elements to the article to be brazed are even more worse, since walls of the container are a thermal shield, and the presence of a screen with the transmission of heat by radiation decreases the heat exchange by two times.

A considerable increase in heating rate with the brazing of thin-walled parts and subassemblies KS can be achieved by the application for heating of metallic or ceramic heating units or quartz tubes, which radiate powerful flows of heat, and also by the electroinduction method.

With the use of these methods of heating, the thermal shield of walls of the chamber of brazing can be made lightened, for example, by means of the installation of several metallic screens. The thermal inertia of such shielding will be low, which will allow cooling rapidly the article together with the chamber for brazing. Special pipes for cooling by running water can be built into the heating units.

§ 6. Preparation of Subassemblies for Brazing

The preparation of subassemblies for brazing consists of the purification of surfaces, applying the solder, assembly, fastening of parts for attachment and the installation of thermocouples.

Purification of surfaces can be fulfilled by mechanical, chemical or ultrasonic methods. In the mechanical method metallic brushes (round rotating by an electrical or pneumatic drill), emery circles, and emery cloth are used. Sand-blast purification is used also. After mechanical purification on the surface there can remain dust, oil, emulsion and other contaminations, which should be removed by washing in solvents or treatment in electrolytic baths.

The chemical method of purification of surfaces is used with large scales of production. It consists in the etching of surfaces by solutions of acids and salts with subsequent neutralization in the solution of soda and thorough washing in running water.

Ultrasonic cleaning of surfaces for brazing is carried out just as in the preparation of parts for welding.

The purification of surfaces should be fulfilled directly before the brazing, since a prolonged storage of purified parts in workshop conditions leads to the formation on surfaces of the parts of oxide films and other contaminations. The greatest permissible time interval between purification and brazing depends on the atmospheric humidity and contamination of it by dust and is determined by experimental means in specific conditions of a given production. In the transportation of purified parts measures of precaution from accidental contaminations are taken: special packing is used, with hand carrying of the part only those surfaces which are not soldered are taken, degreased gloves are used, etc.

Solder is applied to surfaces to be soldered by the galvanic method, by spraying or is used in the form of foil.

The process of applying solder by the galvanic method is analogous to the process of applying protective coverings. The thickness of the deposited layer of solder depends on the time of the parts in bath with an electrolyte. The necessary thickness of the layer of solder for brazing is determined from the condition of filling of all clearances between the parts with an addition of 30-50% for the strengthening of seams and compensation of shrinkage with hardening of the solder.

The applying of solder on surfaces to be soldered by the method of spraying is carried out by metallizing (metal pulverization) or the plasma method. The essence of the process of metallizing consists in the fact that the metal (solder) is melted and atomized

by a stream of compressed air on small particles, which at high speed (100-150 m/s) hit against the surface and, being linked with it, form the layer of coated metal. Metallizing is carried out by special apparatuses (metal spray guns), in which fusion of the metal is conducted by an electrical arc (electrometallizing) or acetylene-oxygen flame (gas metallizing). In a metallizing apparatus by an electrical arc or the burning of acetylene in oxygen there is created a zone of high temperature, in which the wire (solder) and stream of compressed air are continuously fed. The wire is melted, and the stream of air crushes the liquid metal into small particles and through the nozzle blows them outside. Industry manufactures metallizing apparatuses both for manual works and for work on a machine.

In the process of atomization the partial oxidation of solder and burning out of certain elements occur, which one should consider in the determination of the composition of solder. Sometimes to avoid the oxidation of solder, atomization is conducted in a medium of neutral gas. The coated layer of solder consists of particles linked with each other and differs from the usual solder by porosity and a somewhat lowered specific weight (8-12%). This should be considered in the determination of thickness of the coated layer, since after melting the density of the solder will again become the same as it was of the solder prior to atomization.

The melted and atomized solder is not all deposited on surface, and part of it is removed with the air or protective gas and contaminates the surrounding atmosphere. Losses of metal (solder) with atomization depend on the composition of the solder and method of metallizing (electrical or gas) and usually are 15-40%. To protect maintenance personnel from the harmful effect of the atomized metal, the work stations of metallizing have good ventilation with the installation of traps and filters on the exhaust lines.

In the operation of the metallizing apparatus in the same conditions, the thickness of the coated layer of the solder depends on the time of operation of the apparatus and on the distance from

the nozzle to spraying surface. It is practically impossible to achieve a uniform layer of solder with manual spraying. Furthermore, the manual method is not productive. Therefore, in mass production spraying by a mechanically moving metal spray gun on a revolving part is used.

Figure 6.4 shows a diagram of the applying of solder on the internal surface of the jacket of the nozzle by metallizing. Jacket 4 is secured in device 3, which is rotated by the faceplate 2 of machine 1. The metal spray gun 5 is secured on the holder 6 and moves by the mechanism of longitudinal feed of the machine. The speed of rotation of part and speed of feed of the metal spray gun are assigned from the condition of obtaining the necessary thickness of the layer of solder.

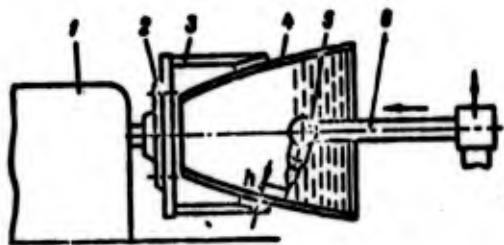

Fig. 6.4. Applying of solder on the internal surface of the jacket of a nozzle: 1 - machine tool; 2 - faceplate; 3 - device; 4 - article; 5 - metal spray gun; 6 - holder.

With the spraying on cylindrical parts these speeds are constant for the whole time of spraying. If, however, the form of the part is not cylindrical (for example, conical, as is shown on Fig. 6.4), then at constant speeds of rotation of the part and feed of the metal spray gun on sections with smaller diameters the speed of movement of the metal spray gun with respect to the surface of the part will be less, and, consequently, the layer of the coated solder is thicker. In order to ensure the uniformity of the layer of solder over the entire surface, it is necessary with transition from one diameter to the other to change the speed of rotation of the part or speed of feed of the metal spray gun, maintaining constant the distance h between the nozzle of the metal spray gun and surface of spraying. Consequently, the metal spray gun accomplishes a complex

motion, which is carried out by hydrocopying or an electronic device.

Solder can be applied between surfaces to be soldered in the form of thin sheets (foil) or tapes. With this method it is easy to achieve the concentration of solder at definite places of the soldered surfaces or an equal distribution of it over the entire surface. The thickness of the foil and distance between adjoining tapes with stacking are determined proceeding from the equality of volumes of the stacked foil and layer of solder in the subassembly after brazing, taking into account the addition for the strengthening of the seams and flowing into adjoining sections. Tapes of foil are stacked on that surface of surfaces the combinable by brazing on which it more convenient to place the solder. With stacking the tapes of solder are fastened to the part by spot welding or another method so that with assembly of the parts a shift in the tapes does not occur.

In certain cases it is required to limit the zone of flowing of the solder, for example, by ends of parts, where subsequently welding will be produced. The presence of solder at places of welding promotes the formation of cracks in a welded seam. There are several methods of limitation of the flow of solder.

1. Polishing of the surface up to a cleanness of $\nabla 13$ – $\nabla 14$; on the polished surface the solder spreads badly.
2. The applying on the surface of a film a mixture of oxides of titanium (TiO_2), aluminum (Al_2O_3) and chromium (Cr_2O_3) prepared on water or alcohol.
3. Chromium plating of the surface (thickness of the layer, 5–10 micrometers) with subsequent oxidation up to a black color.
4. Rubbing of the surface with chalk.

However, these methods do not always guarantee full protection from the spreading of the solder, and then it is necessary to produce dressing of the surface after brazing.

For the purpose of the protection of rust-resistant and heat-resistant alloys from oxidation in the process of heating and also for the improvement of wettability and conditions of flowing of solder, on the surface of the parts sometimes there is preliminarily applied an intermediate layer of metal, the oxides of which are easily reduced in a medium of protective gases. For these purposes frequently copper, nickel and certain special alloys are used. A layer with a thickness of 10-15 μm is applied by the galvanic method.

The technology of assembly of the subassembly for brazing and devices used with this basically depend on the design of the subassembly and are developed in every separate case. However, certain general requirements exist.

1. First of all it is required to gather and fix the parts to be soldered in the subassembly in such a manner so that with transportation of the assembly to the place of brazing, loading into the furnace or container and in the process of brazing there would not be a displacement of parts relative to one another. Displacement of the parts can disturb the assigned constructive form of the subassembly or lead to desoldering and destruction of seam in the process of thickening of the solder.

2. Design of the device and methods of fastening of the soldered subassembly to the device must be such that in the process of heating and cooling there does not appear stresses in the subassembly due to thermal linear expansion of metals of the design and soldered parts. In necessary cases guaranteed clearances or compensators are provided. The application of stiffening, neglecting thermal expansions and elongations, leads to the formation of cracks or warping.

3. Material of the devices should possess a sufficient safety factor at the temperature of brazing.

4. The device should allow the soldered subassembly to be heated and cooled evenly. Bulky massive design create at places of contact with the soldered parts zones of delay in heating (or delay in cooling).

With the soldering of thin-walled parts, which are basic parts of the KS, special attention should be given to the guarantee of contact of the parts with each other in the process of brazing and cooling. Without the application of special pressing devices the thin-walled parts with heating and cooling, as a rule, are warped, in consequence of which the contact of the surfaces to be soldered is disturbed, and desolderings breaks in seams and other defects appear. Several methods of the clamping of thin-walled elements to each other exists.

Figure 6.5 gives a diagram of clamping of parts with the use of external air or gas pressure and vacuum [3].

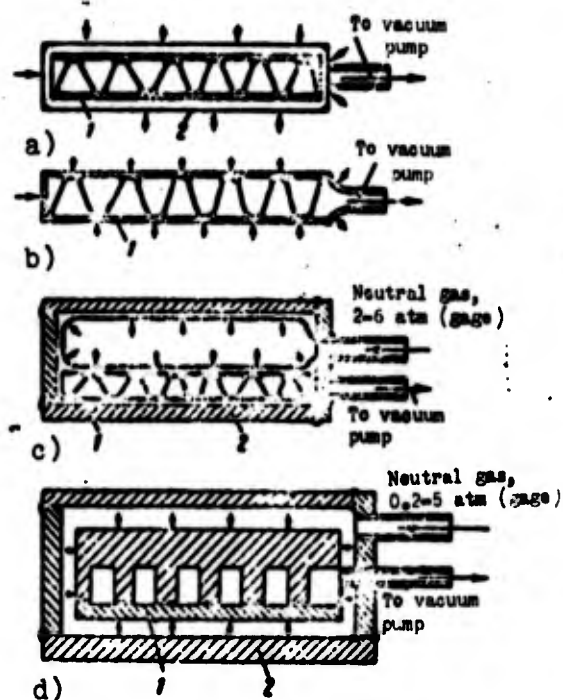

Fig. 6.5. Methods of clamping of thin-walled parts with brazing:
1 - article to be soldered; 2 - container.

With respect to diagram a subassembly 1 to be soldered is placed into a container 2 with thin walls. With the pumping out of air from container the external atmospheric pressure compresses the walls of the container and, thus, evenly presses parts to be soldered to each other.

With respect to diagram b subassembly to be soldered is hermetically sealed by means of welding of the upper and lower parts along the contour. With the pumping out of air from the internal cavity the external pressure presses the thin-walled sheets toward the middle corrugated part. Such a scheme can be used when brazing in a medium of protective gases.

With the necessity of a more dense compression of the parts to one another diagrams c and d can be used.

With respect to diagram c subassembly to be soldered is placed into the thick-walled container 2. Above the subassembly a steel thin-walled bag is placed. In the container a vacuum is created, and fed into the internal cavity of the bag is gas under pressure. The wall of the bag encircles the surface of the subassembly and presses it to the wall of the container. The degree of compression is regulated by the magnitude of gas pressure in the bag. With this method one should consider that walls of the steel bag possess rigidity, in consequence of which it is impossible to achieve dense encompassing and uniform pressure on the whole surface of the subassembly, especially if the subassembly has an uneven surface. Furthermore, the lower side of the subassembly is pressed toward the thick wall of the container, which does not change its form, and consequently, it cannot compass the surface of the subassembly.

With respect to diagram d subassembly 1 to be soldered is hermetically sealed by welding along the contour and is placed into the thick-walled container 2. In the internal cavity of subassembly to be soldered a vacuum is created, and in container - excess pressure. With this method a uniform compression of the parts on all sides is attained. The force of compression is regulated by the change in gas pressure inside the container.

§ 7. The Brazing of Subassemblies

The preparation of the furnace and process of brazing depend on medium in which the brazing occurs. When brazing in a reducing medium it is necessary to observe strictly the order of operation of the furnace, since many reducing media are explosive or poisonous.

Media containing hydrogen are the most explosive. A mixture of hydrogen with air is explosive in the large interval of percentage of hydrogen - from 3.3 to 81.5% by volume. Therefore, before the inclusion of electrical current for heating, it is necessary in furnace to create an explosion-proof medium. This is attained by the blowing of the furnace with gas in a cold state.

The gas outgoing from the furnace should depart by the ventilation system in order to avoid contamination of the air. Many gases coming out of the furnace are poisonous. Especially poisonous is carbon monoxide - a colorless gas heavier than air not having an odor.

After blowing the feeding of electric heater elements for heating the furnace up to the required temperature is included. With the heating of the furnace the gas continuously enters into the furnace and emerges through the control tubes. If the gas is combustible, then at the outlet it is burned, forming a control flame.

With the loading or unloading of the subassembly to be soldered into and out of the furnace, it is necessary to take measures that the atmospheric air does not enter into the furnace and does not form an explosive mixture. Chamber furnaces with a periodically opened door are equipped with special locks in front of the door, which prevent air from entering into the furnace.

With brazing in a medium of neutral gas the preparation of the furnace is simplified since there is no danger of an explosion. Heating of furnace can occur without preliminary blowing; blowing of the furnace is carried out at the end of the heating up. Inert gas for blowing must be 4-5 times more than the active volume of the

furnace in order to completely remove the entire air from the furnace. Upon the achievement of the rated temperature loading of the furnace and brazing of the subassembly are conducted.

With brazing continuous control of the temperature of the furnace and temperature of the soldered subassembly is necessary. Here the irregularity of heating of the subassembly is considered due to various distances of separate sections of the surface of the subassembly from heating elements, the effect of elements of devices and other factors. Therefore, the temperature of the soldered subassembly is measured at several characteristic points. The time of heating of the subassembly up to the temperature of the brazing and time of exposure at this temperature are determined by experimental means.

With brazing in the container, the article to be soldered together with the device for fastening is laid into the container, and the cover of the container is tightened. After that blowing of the container by inert gas and then loading of the container into the furnace and heating to an assigned temperature are carried out. After exposure at the temperature of brazing, the container is removed from the furnace and cooled in air or in liquid. Blowing by neutral gas is conducted continuously with loading, brazing and cooling. The degree of cooling is determined by technical conditions of the surface of the subassembly to be soldered. If on the surface of the subassembly the film of oxides is allowed, then cooling is conducted down to a temperature of the subassembly of 500-600°C, and the container is uncovered. If, however, the surface should be clear and oxides are not allowed, then cooling is continued down to a temperature of 200-230°C.

If opening of the container is produced on metal-cutting machines by means of cutting off, then the temperature of the wall of the container is determined by the condition of safe operation of machine-tool operator.

§ 8. Quality Control of Brazing

The quality of connections by brazing requires the carrying out of thorough control in the preparation of parts for brazing with assembly for brazing, in process of brazing and subsequent control of the finished subassemblies. In the preparation of parts for brazing the quality of purification of the surface, the thickness of the applied layer of solder or regularity of stacking of the foil, and geometric dimensions of parts are controlled. With assembly the whole process of assembly is controlled. Special attention with the assembly of thin-walled parts is given to the control of the magnitude of clearances between the parts and absence of stresses with the fastening of the subassembly to the device. In the process of brazing conditions of brazing - medium, temperature, time of exposure, etc., are controlled continuously.

After brazing every subassembly is subjected to quality control of brazing by visual inspection, hydro- and pneumatic tests, X-ray radioscopy of seams and other methods, analogous those used with quality control of welded seams.

A difficulty in exposure of defects of brazing of subassemblies of the KS consists in the fact that the connection of parts occurs over a large area with small thickness of the stack. Almost all seams are closed, inaccessible to inspection and simple control.

Hence there follows the requirement of strict observance of the technological process. In every operation of the preparation of parts for brazing for the assembly of parts and for the carrying out of brazing (including cooling after brazing), there must be operation production flowcharts with a detailed breakdown into transitions with indication of conditions, periods of exposure, etc. During the observance of this technological process strict technical control should be established. Only under this condition can one assume that the quality of brazing of all subassemblies is equal.

After brazing every subassembly is subjected to control without destruction of the seams. The methods and means for such control are selected depending upon technical requirements for the subassembly during its operation in real conditions. Usually tests for strength of the connection of parts, airtightness of the seams and passability of channels of cooling are conducted. Strength is checked by a hydrotest of the subassembly. For this the interjacket space is hermetically sealed and is filled with liquid (usually water with an impurity of bichromate for the prevention of corrosion) and pressure provided for by the TU (technical conditions) for tests is created. The pressure of the hydrotest exceeds the operating pressure in the subassembly by 20-50%. After the test the subassembly is inspected. If the hydrotest were successful and no breaks or noticeable deformations were revealed, then, obviously, the subassembly can be allowed to operate in conditions of strength.

After hydrotests the interjacket space is ventilated by air for the removal of moisture, and drying of the subassembly is conducted. Then pneumatic tests for density are conducted. Air under pressure determined by TU in tests is fed into the interjacket space and places of possible leakinesses are smeared with soap emulsions. With the outlet of air through the pores, air holes cracks and other leakinesses, soap bubbles revealing places of leakinesses will be formed. Sometimes, if the construction permits, the whole subassembly is placed into a water bath, and by the forming bubbles of air the place and character of the leakinesses are determined. It is necessary to consider that tests by air with smearing by the soap emulsion or submersion of the subassembly into water reveal only sufficiently great leakinesses. Air possesses a noticeable viscosity and does not penetrate through very small leakinesses. If by the TU very high airtightness of the subassembly is required, then a test is conducted by an air-helium mixture. Helium has very small viscosity and penetrates through the smallest leakinesses. Detection of places of nonhermeticity is conducted by helium leak detectors, the arrangement and operation of which are described in special literature.

§ 7. The Brazing of Subassemblies

The preparation of the furnace and process of brazing depend on medium in which the brazing occurs. When brazing in a reducing medium it is necessary to observe strictly the order of operation of the furnace, since many reducing media are explosive or poisonous.

Media containing hydrogen are the most explosive. A mixture of hydrogen with air is explosive in the large interval of percentage of hydrogen - from 3.3 to 81.5% by volume. Therefore, before the inclusion of electrical current for heating, it is necessary in furnace to create an explosion-proof medium. This is attained by the blowing of the furnace with gas in a cold state.

The gas outgoing from the furnace should depart by the ventilation system in order to avoid contamination of the air. Many gases coming out of the furnace are poisonous. Especially poisonous is carbon monoxide - a colorless gas heavier than air not having an odor.

After blowing the feeding of electric heater elements for heating the furnace up to the required temperature is included. With the heating of the furnace the gas continuously enters into the furnace and emerges through the control tubes. If the gas is combustible, then at the outlet it is burned, forming a control flame.

With the loading or unloading of the subassembly to be soldered into and out of the furnace, it is necessary to take measures that the atmospheric air does not enter into the furnace and does not form an explosive mixture. Chamber furnaces with a periodically opened door are equipped with special locks in front of the door, which prevent air from entering into the furnace.

With brazing in a medium of neutral gas the preparation of the furnace is simplified since there is no danger of an explosion. Heating of furnace can occur without preliminary blowing; blowing of the furnace is carried out at the end of the heating up. Inert gas for blowing must be 4-5 times more than the active volume of the

furnace in order to completely remove the entire air from the furnace. Upon the achievement of the rated temperature loading of the furnace and brazing of the subassembly are conducted.

With brazing continuous control of the temperature of the furnace and temperature of the soldered subassembly is necessary. Here the irregularity of heating of the subassembly is considered due to various distances of separate sections of the surface of the subassembly from heating elements, the effect of elements of devices and other factors. Therefore, the temperature of the soldered subassembly is measured at several characteristic points. The time of heating of the subassembly up to the temperature of the brazing and time of exposure at this temperature are determined by experimental means.

With brazing in the container, the article to be soldered together with the device for fastening is laid into the container, and the cover of the container is tightened. After that blowing of the container by inert gas and then loading of the container into the furnace and heating to an assigned temperature are carried out. After exposure at the temperature of brazing, the container is removed from the furnace and cooled in air or in liquid. Blowing by neutral gas is conducted continuously with loading, brazing and cooling. The degree of cooling is determined by technical conditions of the surface of the subassembly to be soldered. If on the surface of the subassembly the film of oxides is allowed, then cooling is conducted down to a temperature of the subassembly of 500-600°C, and the container is uncovered. If, however, the surface should be clear and oxides are not allowed, then cooling is continued down to a temperature of 200-230°C.

If opening of the container is produced on metal-cutting machines by means of cutting off, then the temperature of the wall of the container is determined by the condition of safe operation of machine-tool operator.

§ 8. Quality Control of Brazing

The quality of connections by brazing requires the carrying out of thorough control in the preparation of parts for brazing with assembly for brazing, in process of brazing and subsequent control of the finished subassemblies. In the preparation of parts for brazing the quality of purification of the surface, the thickness of the applied layer of solder or regularity of stacking of the foil, and geometric dimensions of parts are controlled. With assembly the whole process of assembly is controlled. Special attention with the assembly of thin-walled parts is given to the control of the magnitude of clearances between the parts and absence of stresses with the fastening of the subassembly to the device. In the process of brazing conditions of brazing - medium, temperature, time of exposure, etc., are controlled continuously.

After brazing every subassembly is subjected to quality control of brazing by visual inspection, hydro- and pneumatic tests, X-ray radioscopy of seams and other methods, analogous those used with quality control of welded seams.

A difficulty in exposure of defects of brazing of subassemblies of the KS consists in the fact that the connection of parts occurs over a large area with small thickness of the stack. Almost all seams are closed, inaccessible to inspection and simple control.

Hence there follows the requirement of strict observance of the technological process. In every operation of the preparation of parts for brazing for the assembly of parts and for the carrying out of brazing (including cooling after brazing), there must be operation production flowcharts with a detailed breakdown into transitions with indication of conditions, periods of exposure, etc. During the observance of this technological process strict technical control should be established. Only under this condition can one assume that the quality of brazing of all subassemblies is equal.

After brazing every subassembly is subjected to control without destruction of the seams. The methods and means for such control are selected depending upon technical requirements for the subassembly during its operation in real conditions. Usually tests for strength of the connection of parts, airtightness of the seams and passability of channels of cooling are conducted. Strength is checked by a hydrotest of the subassembly. For this the interjacket space is hermetically sealed and is filled with liquid (usually water with an impurity of bichromate for the prevention of corrosion) and pressure provided for by the TU (technical conditions) for tests is created. The pressure of the hydrotest exceeds the operating pressure in the subassembly by 20-50%. After the test the subassembly is inspected. If the hydrotest were successful and no breaks or noticeable deformations were revealed, then, obviously, the subassembly can be allowed to operate in conditions of strength.

After hydrotests the interjacket space is ventilated by air for the removal of moisture, and drying of the subassembly is conducted. Then pneumatic tests for density are conducted. Air under pressure determined by TU in tests is fed into the interjacket space and places of possible leakinesses are smeared with soap emulsions. With the outlet of air through the pores, air holes cracks and other leakinesses, soap bubbles revealing places of leakinesses will be formed. Sometimes, if the construction permits, the whole subassembly is placed into a water bath, and by the forming bubbles of air the place and character of the leakinesses are determined. It is necessary to consider that tests by air with smearing by the soap emulsion or submersion of the subassembly into water reveal only sufficiently great leakinesses. Air possesses a noticeable viscosity and does not penetrate through very small leakinesses. If by the TU very high airtightness of the subassembly is required, then a test is conducted by an air-helium mixture. Helium has very small viscosity and penetrates through the smallest leakinesses. Detection of places of nonhermeticity is conducted by helium leak detectors, the arrangement and operation of which are described in special literature.

Continuity tests of channels of cooling are conducted by sending water through these channels. The degree of narrowing of the channel is determined by the measurement of the flow rate per second of water through every channel under a defined inlet pressure. The permissible oscillation of the flow rate of water is established by the TU on a test of the given subassembly.

With tests for strength and airtightness general characteristics of the brazed subassembly are determined, but local hidden flaws of brazing are not revealed. The latter are revealed only by X-ray or ultrasonic control and with opening of the joint.

Full comprehensive quality control of brazing is conducted by means of cut of control subassemblies. As the control any commodity subassembly from a given group of subassemblies prepared by mass production can be taken. The quantity of control subassemblies from the group is determined by technical conditions.

The subassembly is cut along the most characteristic sections. At several places one part along the joint is detached, as is shown on Fig. 6.6., the seams are inspected, and all flaws of brazing are revealed.

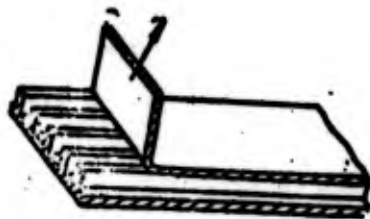

Fig. 6.6. Check of the quality of brazing on a separation of a sheet.

Characteristic flaws of brazing are the following.

1. Nonsoldered areas are sections of the surface where connections of parts by solder did not occur. Very frequently nonsoldered areas will be formed due to poor wetting of surfaces to be soldered by solder, which is explained most frequently by poor preparation of surfaces before brazing: residues of oxide film, the presence of scratches on soldered surfaces located across the

direction of flowing of the solder. With poor wetting in the tee connection of parts the seams are convex and intermittent.

Figure 6.7a shows the form of seams which are formed with good wetting and spreading of the solder. Solder in angles will form a concave meniscus. On Fig. 6.7b the form of seams formed with poor wetting: at some places there is much solder and a convex meniscus if formed, and in other places there is no solder or it was not connected with the surface of the part. A nonsoldered area will be formed also with insufficient activity of the flux when brazing with flux or when the medium with brazing in inert gas is contaminated; with insufficient rarefaction or the presence of harmful vapors with brazing in a vacuum; with insufficient heating of the parts; with an insufficient quantity of solder. The cause of the nonsoldered areas may also be an incorrectly selected clearance between the parts or irregularity of the clearance. In large clearances the solder is not held by capillary forces and flows into adjacent sections, forming a nonsoldered area. With a very small clearance or in the absence of a clearance the solder is not able to penetrate between the parts, and a nonsoldered area will also be formed.

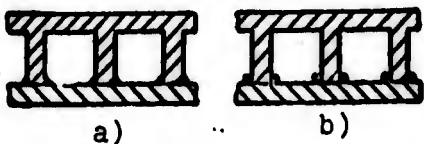

Fig. 6.7. Form of seams with a tee connection of parts.

2. Undercuttings of basic metal, which are formed due to corrosion of the surface of the soldered metal by solder, decrease the section of parts and lower their strength. They are especially dangerous under vibration loads, since they are concentrators of stresses. Corrosion of the surface by solder is possible when the solder and metals to be soldered form eutectic or solutions with a low melting point. Undercuttings will be formed at excessive temperature of the brazing, with prolonged time of heating or exposure, and with an accumulation of a large quantity of solder

at one place. Undercuttings can be avoided if one were to regulate strictly the quantity of solder and conditions of the brazing: temperature of the brazing, time of exposure, and speed of cooling.

3. Slag and flux inclusions in the seams appear as a result of poor displacing of the flux with solder. With slow heating of the subassemblies assembled with small clearances, the flux dissolving the surface oxides changes its composition, becomes viscous and departs poorly from the small clearances. With nonuniform clearances or nonuniform heating of the soldered surfaces, the solder spreads nonuniformly and can surround certain sections of the flux, preventing its removal. With the flowing of solder into the clearance on two sides simultaneously, the flux cannot emerge from the clearance, forming an inclusion and nonsoldered area. Flux and slag inclusions lower the strength of the connections, especially when they are located at the beginning of the clearance on the fillet, since they are in this case concentrators of stresses. At present brazing of important subassemblies of the KS is produced without the application of fluxes, and, consequently, this flaw is absent.

4. Gas pockets and porosity of the seam appear as a result of the congealing of the seam of part of the gases separated with brazing. Gases will be formed as a result of the decomposition of the flux or chemical interaction of the gas protective medium with the solder or metal of the parts to be soldered. Decomposition of the flux (boiling) is observed with overheating or in the presence of moisture in the flux. With poor purification of surfaces before the brazing, the flux interacts with residues of the oxides, grease, dirt and here gases are separated also. The number of gas pockets in the seam increases with an increase in area of the joint, since the exit of the gases is hampered. With brazing in a vacuum gas pockets and porosity in the seams are not observed.

5. Cracks in the metal of the seam appear in the presence of tensile stresses in the seam during its cooling. These tensile stresses appear for various reasons. One of them is the shrinkage

of the solder with its crystallization. If a corner seam (fillet) is unnecessarily high and the solder forms a convex meniscus, then shrinkage of the solder can lead to the formation of a crack. With local overheating of the metal of the parts to be soldered in the weld-affected zone and low thermal conduction, especially of stainless steels and heat-resistant alloys, a tensile stress can appear, which sometimes leads to the formation of a crack in the solder. Tensile stresses in the seam appear also due to the different magnitude of shrinkage with cooling of the soldered parts and solder, if coefficients of linear expansion of metals of combinable parts and the solder are unequal. If the difference in shrinkage of the parts in the process of crystallization of the solder is great, and the solder does not have sufficient plasticity, then the formation of cracks is possible.

6. Cracks in the metal of soldered parts appear during the action of tensile stresses on the metal, the strength and plasticity of which are weakened as a result of the interaction the liquid solder with the surface of the parts to be soldered. The lowering of the strength and plasticity of the metal with the wetting of it by another molten metal (solder) is explained by the lowering of the surface energy of the hard metal with adsorption (absorption) by the surface of the metal of liquid solder. The metaled solder penetrates into microscopic cracks on the surface of the metal and unwedges them, which promotes brittle fracture.

Different solders unequally lower the strength of the metals. For example, with the contact of liquid silver solder PSr25 with stainless steel 1Kh18N9T the strength of the latter decreases by 11%, and with the contact of this steel with a liquid copper-zinc solder the strength of the steel decreases by 35%. The heat-resistant alloy EI437B, covered with liquid cadmium, loses its strength by 70%, and the elongation of it descends to zero [3].

In order to prevent the formation of cracks in the metal of soldered articles with brazing, one should not allow tensile stresses, which can appear as a result of negative allowance and misalignments

with assembly, stresses from the irregularity of heating, redistribution of internal stresses with the heating of cold-worked parts, rigid fixation of the subassembly on the device, which does not allow freely to be extended and expanded to the parts. These circumstances must be considered in the development of the technological process of assembly for brazing and the process of brazing. In particular, thin-walled parts with stamping and calibration are cold-worked, and, consequently, it is required to anneal them for the removal of internal stresses. The process of annealing can be combined with brazing, if the temperature of the annealing is considerably lower than the temperature of the brazing.

CHAPTER 7

MANUFACTURE OF INJECTOR HEADS

§ 1. General Requirements

The head of a combustion chamber (see Fig. 1.2) is its most important part intended for the putting into the chamber of a mixture of fuel and oxidizer in the assigned proportion and prepared for rapid and full combustion of it in a small volume.

The burning of fuel components occurs in the gas phase with the mixing of gaseous molecules of the fuel and oxidizer in a proportion necessary for burning. For correct organization of the process of burning, it is required to form a uniform gas mixture of the fuel and oxidizer, evenly distributed along the section of the chamber. With poor mixing the time of burning is increased and great volume of the chamber is required, which increases the weight of the engine. With nonuniform mixing along the section of the chamber in separate sections an incompleteness of the combustion will be observed, which will lead to thrust decay of the engine.

The fuel and oxidizer are introduced into the chamber in most cases in liquid form through injectors into a finely crushed, atomized state. Under the effect of high temperature in the chamber the small particles of liquid instantly evaporate, and the gases forming enter into the chemical reaction of burning. The thinner the

atomization, the more the process of evaporation and combustion. Therefore, injectors in the head must atomize the components well and mix them. The latter is attained by the corresponding location of the fuel injectors and oxidizer over the area of the base of the injector head of the chamber. The arrangement of fuel injectors and oxidizer along alternating concentric circumferences, staggered location, honeycomb and other combinations, depending upon the weight or volume the fuel-oxidizer ratio is used.

The flow rate of the liquid through every injector is usually not great, and the injectors are many (in order to attain good mixing as near as possible to the base of the head in minimum volume). For example, in the head of the American engine F-1, having a thrust of 680 t, there are 2600 oxidizer injectors with a total flow rate of 1800 kg/s and 3700 injectors of a combustible with a total flow rate of 1000 kg/s. The diameter of the injector head is 1016 mm. Consequently, on the average for each 1.3 cm^2 of area of the base of the injector head, one injector is necessary.

With respect to their design the heads are divided into spheric, tent and flat depending upon the form of the bottom, which limit the internal cavity of the combustion chamber (fire base).

Figure 7.1 gives simplified diagrams of heads: a) spheric type, b) tent type, c) with a flat fire base.

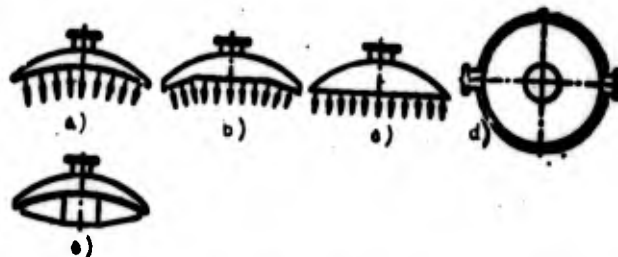

Fig. 7.1. Forms of injector heads.

The oxidizer is fed from above. However, lateral feed is used. As an example Fig. 7.1d shows a diagram of bilateral feed of the oxidizer into the head of the engine.

The process of the creation of a new efficient injector head is complex and prolonged, which in many respects determines the periods of the creation of the engine. The design of the head is governed by the quality of atomization and mixing and consequently, stability of the burning. Sometimes for the improvement of mixing, on the fire base special partitions are made as is schematically shown on Fig. 7.1e. The form, dimensions and quantity of partitions are determined by experimental means. To protect the walls of the partitions from burning, inside the partitions liquid coolant circulates.

In the manufacture of heads high technical conditions required: the error of $\pm 0.1-0.3$ mm in distribution of injectors in the base is allowed, the error in total flow rate of fuel components through the head and error in flow rate through every injector of 1-4%, accurate coincidence of the axis of the flame of the mixture with the axis of combustion chamber, complete airtightness of the seams, and high cleanness of cavities. The fulfillment of these requirements is possible only with the equipping of the technological process with contemporary equipment, high industrial production and with thorough post-operation technical control. In contemporary combustion chambers the most frequently used are heads with a flat fire base, which ensure good mixing and are the simplest to manufacture.

Let us consider the basic stages of the technological process of manufacture of the head (FG) with a flat fire base [2, 3, 6, 5].

Figure 7.2 shows a simplified diagram of the mixing of such an injector head [5]. It consists of a power ring, or casing of the head 1, upper base 2, middle base 3, fire base 4, and injectors of fuel 5 and oxidizer 6. The fuel proceeds through lateral holes in the power ring according to the arrow Γ fills the space between the middle and fire bases and through injectors 5 is injected into the combustion chamber. The oxidizer proceeds according arrow 0 into 7

welded into the upper base, passes through holes in the pipe, fills the space between the upper and middle base and through injectors 6 is injected into the chamber. To create rigidity between the upper and middle bases, stiffeners 8 and between the middle and fire bases - distance bushings, 9 are set. Instead of distance bushings it is possible to provide appropriate bosses of casings of injectors of oxidizer.

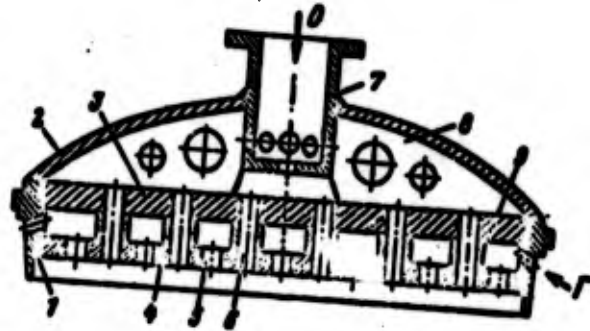

Fig. 7.2. Design of a head with a flat base: 1 - power ring; 2 - upper base; 3 - middle base; 4 - fire base; 5 - fuel injector; 6 - oxidizer injector; 7 - pipe; 8 - stiffener; 9 - distance bushing.

For the manufacture of parts of heads, stainless steels of the type 1Kh18N9T and alloys of the type EI554 and EI712 are used. For heads of engines, operating on nonaggressive fuel components, low-carbon steel are also used. For the fire base alloys with copper as a base or the type of bronze BrKh0.8 and other alloys are sometimes used [5].

§ 2. The Manufacture of Power Rings of the FG

The design of the power ring is determined by the configuration of the head and the method of connection with adjoining parts. Figure 7.3 shows a cross section of a characteristic power ring. Thin lines designate parts adjoining to the ring: upper, middle and fire

base, wall of the chamber, and jacket of the chamber. In the manufacture of ring dimensions D_1 , D_2 , D_3 , D_4 and H must be carried out with great accuracy. Dimensions D_2 and D_3 , which the position of the middle and fire bases, must be fulfilled exactly and to be coaxial, since the displacement of these bases relative to one another will cause misalignment of axes of injectors of the oxidizer. Dimension D_4 determines the position of the head with respect to the combustion chamber.

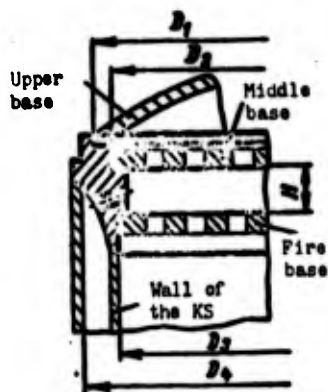

Fig. 7.3. Power ring of an FG.

The billet for the ring is obtained by stamping or rolling. In the manufacture of rings from stamped billets there is used much metal scrap from shavings (70% and more), since stamps for more exact stamping are comparatively expensive. More rational billets with less metal scrap are obtained by the method of rolling by shape rollers on special rolling machines. Figure 7.4 depicts a diagram of such a machine. The initial billet for rolling is a ring, obtained by casting, forging or other method. Before the operation of rolling the billets are subjected to coarse machining (roughing) for removal of the surface defective layer. Rolling is produced in a heated state at the forging temperature for the given metal or alloy. The billet 1 is set between rollers 2 and 3. Roller 2 revolves in a fixed bearing subassembly 5, and roller 3 - in bearing subassembly 4, which travels in a vertical direction and transmits a force of pressure of the roller with rolling. From lateral displacements the billet

is held by spring rollers 8, which with an increase in diameter of the billet are released to the sides. Upon the achievement of the assigned dimension the billet touches the roller 10, turns it and includes the command apparatus 9, which will give a signal to stop the process of rolling and removal of the rollers.

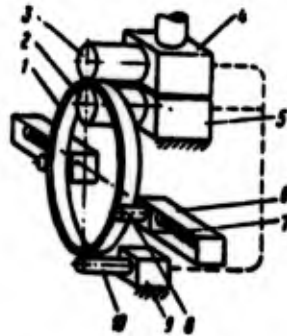

Fig. 7.4. Diagram of a machine for the rolling of rings: 1 - billet; 2, 3 - rollers; 4 - bearing subassembly; 5 - fixed bearing; 6 - shoe; 7 - spring; 8 - lateral supporting rollers; 9 - command apparatus; 10 - roller.

The form of the rolled procurement is determined by shape of rollers 2 and 3. For the transition to the roller of billets of another type, it is required only to change the embossing rollers. Expenditures for the manufacture of rollers is considerably less than those in the manufacture of a new stamp. With rolling the material is deformed, forming a tight structure with high mechanical qualities. Allowances for subsequent machining are 2-4 mm. Billets with still smaller allowance, a total of 0.5-1.5 mm, with high mechanical qualities of the metal can be obtained by the method of bending of profile strips with subsequent butt seam welding. Profile bands are obtained by rolling or hot pressing.

Figure 7.5 gives a diagram of the pressing of profiles on a horizontal press. The cylindrical billet 3 is heated in a medium of neutral gas or in a salt bath, is wrapped by a tissue of fiberglass and is filled into container 2. The diameter of the billet should be 4-6 mm less than the diameter of turning in the container so that the billet enters freely. Then by plunger 1 a pressure of 1200-1600 MN/m² and more is created depending upon the brand of the pressed material. Under the action of this pressure the material

starts to proceed through the profiled hole (eye) of the die plate 4 made from a heat-resistant alloy of the type ZhS6. Here the facing of fiberglass is melted, forming a liquid film, which serves as the lubrication between the pressed material and walls of the container and eye of the die plate. The pressed profiled band 8 from the die plate enters into the receiver 7 for protection from twisting. The die is secured in the die 5 and is cooled by a channel of water through tubes 6. In such a way it is possible to press carbon and stainless steels of the type 1Kh18N9T and other materials. The material after pressing has a tight fine-grained structure with high mechanical properties.

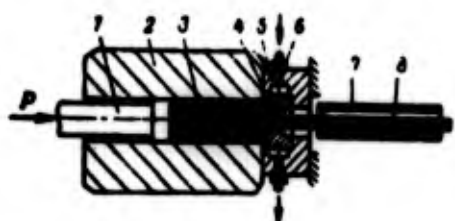

Fig. 7.5. Pressing of profile strips: 1 - plunger; 2 - container; 3 - billet; 4 - die plate; 5 - die; 6 - cooling feed; 7 - receiver; 8 - profile.

After the cutting of the strip into measuring segments. bending of rings is fulfilled on a profile-bending machine, for example one of the type PG4. A diagram of the operation of the machine is shown on Fig. 7.6. The machine has an overhead drive roller 1, lower support roller 4 and two lateral bending rollers 3 and 5. The position of the rollers in height is determined by the degree advancement of rods 6 of the hydrocylinders. The rectilinear profile of the band 2 is filled between the upper 1 and lower 4 rollers with lowered bending rollers, as is shown by the dashed line on diagram a. Then roller 3 is raised to the assigned height, and by rotation of the drive roller clockwise bending of the strip to the position shown on diagram a is produced. After this the direction of rotation of roller 1 is changed to the opposite, roller 5 is raised to the level of roller 3, and final shaping of the ring, as was shown on diagram b is produced.

After bending the rollers are removed, and the ring is released. Then the ring is welded by argon arc welding or butt seam welding with fusion on an installation of the type MGSA-300. Copper contact shoes seize both ends of the bent strip near the joint, and

special devices compress the ends with the assigned pressure. Electrical current of great density passing through the joint heats the ends up to fusion, and the pressure tightly presses them to one another, as a result of which welding is produced. Due to the fusion an upsetting of faces of 8-12 mm occurs, which can be considered in the determination of the length of the billet.

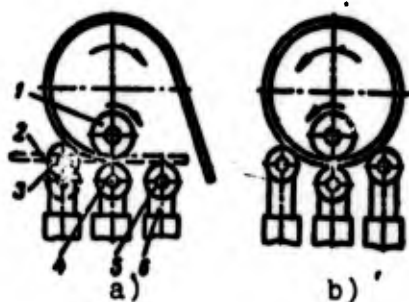

Fig. 7.6. Diagram of the operation of a profile bending machine: 1 - drive roller; 2 - billet; 3, 5 - bending rollers; 4 - support rollers; 6 - rod of the hydrocylinder.

After welding the seam is cleaned, heat treatment for the removal of internal stresses is conducted, and calibration for the purpose of the correction of warpings with heat treatment is performed. Good results of the calibration are obtained with a certain extension of the ring with simultaneous compression on ends in special stamps.

The machining of power rings of the FG from billets obtained by stamping or rolling is conducted usually in two stages: rough treatment, at which 70-80% allowance is taken, and finishing - for obtaining the final dimensions. Such a separation of operations is caused by the fact that after removal of the allowance, the relatively thin ring is deformed under the action of redistribution of internal stresses in the metal - ellipticity, warping of faces and other defects appear. To correct these defects, finishing operations are specified. Machining is produced on turning, facing or vertical turret lathes. In the first rough operation the billet is based by the external

diameter and end. Here turning of the internal surface and treatment of the free end and part of the external surface are produced, as is shown on Fig. 7.7a. Places of treatment are outlined by a heavy line, and the allowance taken is designated by a dashed line.

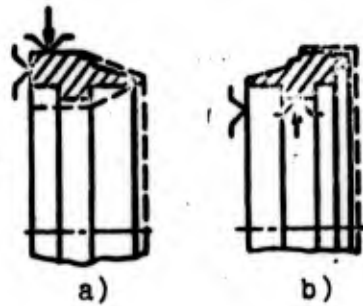

Fig. 7.7. Operation sketches of the machining of a ring.

Figure 7.7b depicts an operation sketch of machining in the second rough operation. Basing is produced by the internal treated surface and second end. External surfaces, the face and groove under the external base are machined. In finishing operations the ring is based on the diameters, and clamping is produced into the face to avoid deformations under the action of forces of the clamp. The number of finishing operations is determined by the configuration of the ring. It is necessary to see to it that all fitting places are treated finally from one installation of the part, since overfastening leads to errors. This especially pertains to the treatment of fitting places of middle and fire bases (diameters D_2 and D_3 on Fig. 7.3). Lateral holes for the input of fuel are drilled after the final lathe work of the ring on a drilling machine with the application of a turning jig or on a special multispindle unit machine tool.

A diagram of the turning jig is depicted on Fig. 7.8. The conductor consists of a casing 1, fixed disk 3, mobile disk 4, shoe 6 and clamp 10. The part 8 to be treated is installed on the support element 9 secured on mobile disk 4. Shoe 6 with jig bushing 7 is

removed to the right, as is shown by the dashed line. The part is fastened by clamp 10. A turn of the part at the assigned angle is produced together with disk 4 with liberated index pin 5. For the selection of the gaps and elimination of vibration, in the process of treatment the selection of the gaps and elimination of vibration, in the process of treatment lock 2 is used.

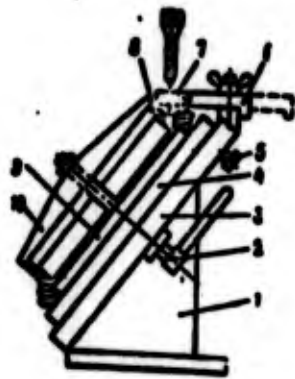

Fig. 7.8. Diagram of a turning jig: 1 - casing; 2 - lock; 3 - fixed disk; 4 - mobile disk; 5 - index pin; 6 - shoe; 7 - jig bushing; 8 - part to be machined; 9 - support element; 10 - clamp.

§ 3. Manufacture of Bases

Bases are prepared from sheet bars cut on guillotine and roller shears or cut out in stamps. The upper base is stamped for the obtaining of a spheric or elliptic form and cutting out of a central hole for the welding of the pipe. Then machining of the faces for welding with basing on the central hole is produced.

The middle and fire base with respect to its design and dimensions are almost identical. A certain distinction is only in the treatment of edges for welding or brazing and in the quantity and dimension of holes under the injectors. Therefore, technological processes of the machining of these bottoms are practically identical, and sometimes both bases are treated in the set jointly.

In operation I of the machining the base for the installation, which is a central hole is created. It is obtained usually with stamping and then is developed for obtaining exact dimensions.

In operation II (Fig. 7.9) is produced machining of the external diameter on a lathe with basing on the central hole and fastening in the face of the base by a revolving clamp set in tail spindle of tailstock of the machine. Usually two bases are machined simultaneously. In operation III treatment is produced of face planes with basing on the external diameter. If billets of bases made from sheets having even clean surfaces, then the face planes cannot be machined. Then the bases are washed, and holes are drilled for injectors (Fig. 7.9, IV). If one of the bases (for example, middle) is welded to the power ring, then the holes are drilled after the welding of the base in order to avoid breaks of the crosspieces between the holes and distortions of the shape of the holes. With the development of the operation of drilling of the holes, it is necessary to consider that in the head of the injector of the oxidizer (and if the injectors are two-component, then all the injectors) are set simultaneously in both bases - middle and fire, consequently, holes under these injectors must be coaxial in the assemblage. The misalignment of holes in the fire base with respect to holes in middle base hampers the installation of the injectors or will cause misalignment of their axes, which will be reflected in the uniformity of the mixture. The allowed error in the direction of axes of the injectors usually does not exceed 20 angular minutes.

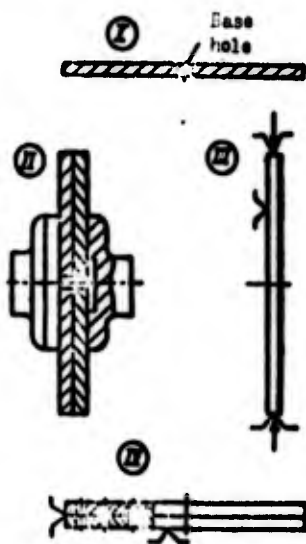

Fig. 7.9. Sequence of the treatment of bases.

Good coaxiality of the holes on the middle and fire bases is attained by the drilling of holes in both bases simultaneously in one jig. It is possible also to obtain satisfactory coaxiality by the drilling of holes separately in every base, but with the help of the same jig plate under a condition of a small clearance between the drill and jig bushings in the plate. The cleanness of treatment and accuracy of making the holes by drilling are insufficient. Therefore, after drilling countersinking and then reaming of the holes are produced. Here simultaneously it is possible to treat the faces, grooves and other deepenings if they are provided for by the design of the base. Operations on the treatment of holes are fulfilled on radial drilling machines by one tool or with the application of multispindle heads.

With the drilling of the holes warping of the plane of the bases is possible due to the redistribution of internal stresses in the metal. If the magnitude of deviations from the plane exceeds the permitted TU allowance (usually 0.4-0.6 mm), then after drilling repeated treatment of faces of the base is conducted. In this case after the first turning of the faces, a left allowance (according to the thickness of the base) on the second surfacing remains. The magnitude of the allowance depends on the degree of warping and is determined by experimental means.

The jig for the drilling of holes for injectors in the bases has 2-3 changeable jig plates, which are made with great accuracy. The manufacture of such a jig occupies much time and requires great labor expenditures. Therefore, in experimental and small-lot productions with frequent replacement of the articles it is expedient to drill holes in bases for injectors without a complex jig on machines with stored control. In such machines movement of the drill with respect to the fixed axis of the drill is carried out by actuators controlled by an assigned program. The whole technological process of the treatment of the part is divided into an exactly calculated complex of consecutive motions of operating units of the machine, for example: turn the table, set the drill, switch on the supply, turn off the supply, take out the drill, etc., which in totality will be the program of the machine operation. This program

is recorded on magnetic tape, punched card or another memory unit, and then, being introduced into the machine through corresponding converters exerts an effect on operating units of the machine, forcing them to fulfill the assigned motions.

§ 4. Manufacture of Injectors

Forms and dimensions of injectors used are diverse. Conditionally they can be divided into two classes:

1) jet injectors - which inject fuel or oxidizer in the form of thin streams;

2) swirlers - which twist the fluid flow and inject the fuel or oxidizer into the chamber in the form of a conical film, which consists of atomized liquid particles.

Figure 7.10 depicts several of the most characteristic designs of injectors: a, b, c - jet injectors; d, e, f, g - swirlers. Jet injectors are exact holes of small diameter carried out in parts fastened to the base or directly in the base: a - jet injector of a simple type; b - injector with a stepped hole; c - injector with colliding streams.

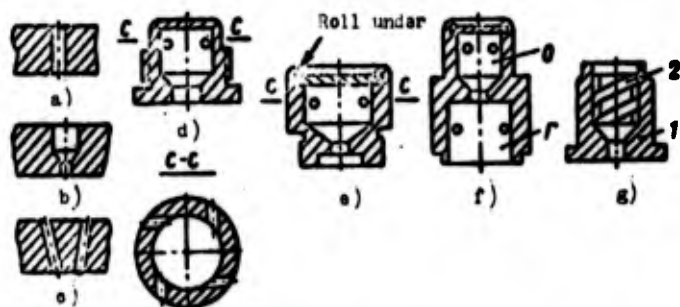

Fig. 7.10. Types of injectors.

In swirlers the twisting of fluid flow is carried out by the tangential input of streams into the cavity of the injector (d, e, f) or with help of a worm conveyer with a big screw thread (g).

As a result of the twist there is created swirl flow of liquid, which emerges through the atomizing hole of the injector. On diagram d a single-component injector of the closed type with a flange is shown. The liquid enters into the cavity of the injector through two (sometimes three or four) holes located tangent to the circumference of the internal boring, as was shown on section C-C.

On diagram e such a single-component injector is shown, but it carried out by assembly for the purpose of simplification of the technology of manufacture. The internal cavity is formed by means of installation into the casing of a blind plug, which is fastened by rolling under the edges of the casing of the injector.

Diagram e shows a two-component injector with tangential input liquid. The injector has two cavities: cavity O for the input of the oxidizer and cavity Γ for the input of fuel. The upper cavity O is formed by the installation and rolling under of the plug, just as in an injector of type e. On the external surface of the injector there is boss, which serves as a spacer between the middle and fire bases. The upper recess of the injector rests in the middle base and the lower - in the fire base. Connection with the bases is carried out by brazing.

On diagram g a single-component screw injector is shown. It consists of a casing 1 and worm conveyer 2. The worm conveyer is held in the casing by pressing or rolling under of the upper edge of the casing of injector. Liquid proceeds from above, flows along screw channels between the casing and worm conveyer and vortex emerges through the atomizing hole. Instead of worm conveyer, a swirl vane of another type can be installed.

Injectors of more complex designs are used. However, the technological process of their manufacture and equipment used in many respects are similar to the process of the manufacture and equipment used in the manufacture of model designs of injectors examined above.

Manufacture of Jet Injectors

In the manufacture of jet injectors the basic difficulty consists in maintaining the rectilinearity of the axis of the hole. In most cases the diameter of the hole of the injector is very small, and the relative length of the drilling is great. Usually the ratio of the length of drilling to the diameter of the drill is larger than five. Such holes are "deep," and with drilling with standard drills "withdrawal" of drill and distortion of the axis of the hole occur. Therefore, it is necessary to use special drills, which possess raised rigidity and operate under unstressed conditions of cutting. To decrease the relative length of drilling, it is rational to use step drilling, as is shown on Fig. 7.10b.

Drilling is fulfilled in two transitions (or in two operations): at first drilling by a tool of larger diameter, then drilling of a small hole. Drilling in a reverse order, i.e., at first the formation of a small diameter and then counterboring of a large diameter, is absolutely impermissible, since the first drilling by a small drill on the whole depth is "deep" drilling, and the whole meaning of the application of the stepped hole vanishes. For the formation of the stepped hole, it is possible to use a combined drill with an offset made in the form of a hole. However, the application of such drills is not always rational, since the tip of a drill of small diameter should drill the whole thickness of the metal and operates in very stressed conditions, and the manufacture of combined drills is considerably more expensive than that of standard drills.

The formation of jet injectors in the base is possible not only by the mechanical method, but also other methods for example, the electrospark method. The electrode is made in the form of a set of rods secured in a common shoe. The diameter of the rods corresponds to the diameter of the injector, taking into account the increase of the hole with realization of the process. The advantage of this method consists in the fact that immediately all injectors are broached.

Here the high accuracy in the mutual location of the injectors without the application of a jig is ensured. The holes are rectilinear, since the electrodes are mechanically not loaded. A substantial deficiency of this method is the relatively rapid wear of electrode rods which creates the necessity of their frequent replacement.

Manufacture of Swirl Injectors

Swirlers with the tangential input of liquid are prepared from rod material on automatic machines or turret lathes with the subsequent formation of tangential holes. Let us examine the technological process of the manufacture of the two-component injector depicted on Fig. 7.10f.

Plan of operations (route procedure):

1. Treatment of external and internal surfaces on the side of the larger diameter on a turret-lathe automatic machine.
2. Treatment of external and internal surfaces on the other side on a turret-lathe automatic machine.
3. Drilling of tangential holes.
4. Stripping of burrs.
5. Washing.
6. Assembly and charging of the plug.
7. Control tests (hydraulic pressure test).

The first operation is fulfilled on a turret-lathe automatic machine of the type 1A118, 1A124 and 1A136.

Approximate sketches of the transitions are depicted on Fig. 7.11.

without

,
l
rode

from
bsequent

l
ed

e of

er

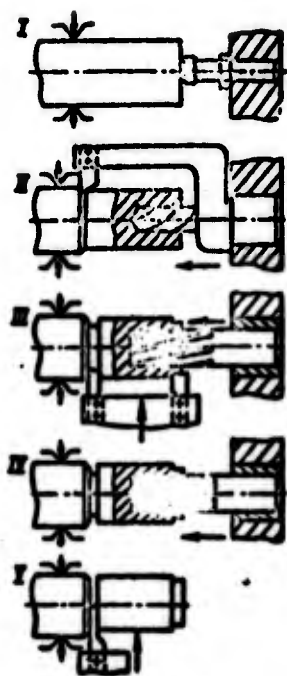

Fig. 7.11. Sketches of transitions of treatment of injectors.

The second operation is fulfilled on a turret lathe of the type 1P326 and 1340A. Approximate sketches of alignment of the machine are given on Fig. 7.12.

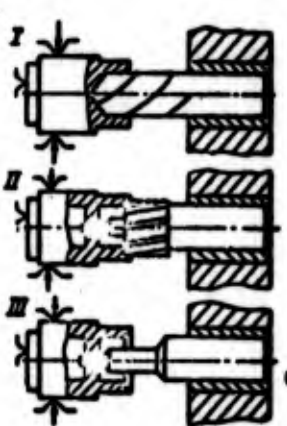

Fig. 7.12. Sketches of alignment of the turret lathe.

ic

g. 7.11.

Drilling of the entrance tangential holes is associated with certain difficulties caused by the one-sided action of forces of cutting on the drill at the beginning and at the end of drilling, as is schematically shown on Fig. 7.13.

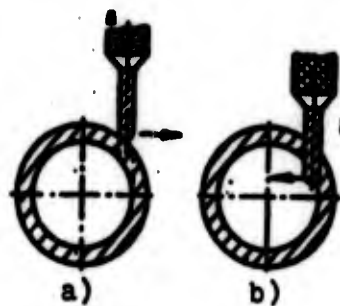

Fig. 7.13. Squeezing of the drill with drilling of tangential holes.

At the beginning of drilling (position a) with lateral fitting of the drill, forces of cutting release the drill from the center of the injector, as is shown by the arrow. At the end of drilling (position b) forces of cutting act on the drill in a reverse direction toward the center of the injector. These forces, acting on the thin drill, which possesses little rigidity, bend, which leads to distortion of the axis of the hole or to an error in the direction of this axis. Meanwhile, to ensure good operation of injector, it is required to direct the stream of liquid strictly along the tangent to the generatrix of the surface of internal groove of the injector. To prevent withdrawal of the drill, jigs with guide bushings, which encircle the external surface of the injector and correct the direction of drilling, taking into account squeezing of the drill, are used. The magnitude of correction is set by experimental means. Here drilling should be produced with a small always identical feeds, since forces of cutting and, consequently, forces of squeezing of the drill depend on the section of the shaving.

Figure 7.14 shows a simple edged jig for the drilling of tangential holes in injectors [5]. Injector 4 is set between prisms 6 and 7 with cleat 2 removed aside with screw 1. To select the gap, prism 6 is made mobile - pressed down by screw 8. Then cleat 2 turns around axis 9 up to the stop when the cut on the second end of cleat 2 will turn on rod 10. Then by the clamping screw 1 the injector is secured. Drilling is produced through jig bushings 5, which encircle the external surfaces of the injector for cancelling forces releasing the drill. After the formation of one hole the jig is edged (turned on the other edge of the casing) 180°, and a second hole through the second jig bushing is drilled. If the injector has four tangential

holes, then, by slightly changing the design of the casing of conductor, it is possible to set four jig bushings and four edges on the casing for edging of 90°.

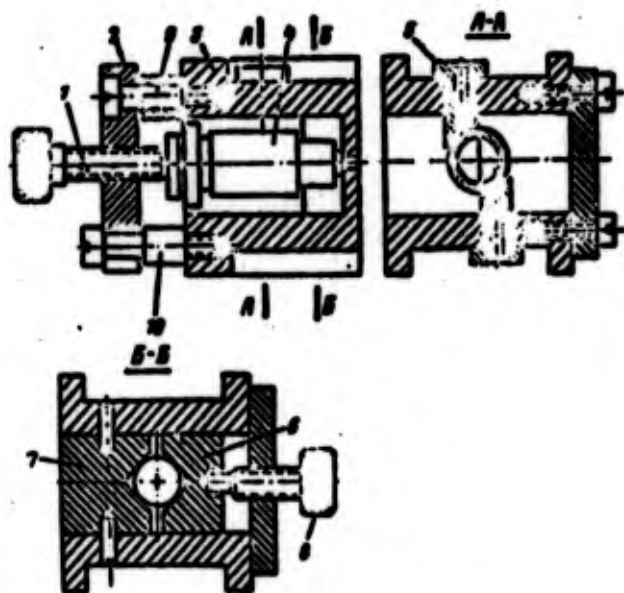

Fig. 7.14. Jig for the drilling of tangential holes in an injector:
 1 - screw; 2 - cleat; 3 - casing;
 4 - injector; 5 - jig bushing;
 6, 7 - prism; 8 - screw; 9 - axis;
 10 - rod.

Drilling is produced on a high-speed table-drilling machine of the type NS-6 or on a vertical boring high-speed semiautomatic machine of another design. On this machine to increase the stability of the drill, a special device is provided for imparting to the tool of vibration oscillations in the direction of the feed. The amplitude of vibrations (with stepless control) is selected depending upon the diameter of the drill and magnitude of feed within 10-100 micrometers (micron).

Exact tangential holes in injectors can be obtained by the method electrospark broaching on semiautomatic machines of EP-5M type. The injector is set in a special turning jig placed in a bath

with kerosene. The electrode is a brass wire, which moves automatically by rollers with deepening in the hole. The diameter of the wire is 15-20% less than the diameter of the broached hole. The moment of termination of the piercing is fixed by a special relay, which gives the command for withdrawal of the electrode wire from the hole and an automatic turn of the injector at the assigned angle for broaching of the following hole. The machine is equipped with a vibration bunker and mechanism of automatic loading with a manipulator for the feed of injectors into the zone of treatment.

In the mass production of a liquid-propellant rocket engine, it is economically expedient to automate the process of the manufacture of injectors, since for every head hundreds, and sometimes thousands of injectors are required, and, consequently, the mass production of the injectors will occur. In the automated process the whole cycle of manufacture of the injector is conducted on a special rotary line or on a machine line from a number of separate machines and automatic machines, united by devices for the automatic transmission of parts from one machine to the other.

Technology of the manufacture of swirlers with swirl vanes

(see Fig. 7.10g) in the part of treatment of the casing is analogous to the technology of treatment of the injector with the tangential input examined above. Furthermore, the swirl vane is prepared and an assembly of the injector is produced separately. The process of manufacture of the swirl vane is determined by its design. A cylindrical screw swirl vane can be made on a turret lathe automatic machine or turret lathe with threading of screw grooves by thread-cutting head of the type 2KA or 2K. Another technological process is more productive:

1. Threading from calibrated stocks of billets with a length of 100-150 mm.

2. Grinding of the external surface of billets on centerless grinder.

3. Rolling of spiral grooves on a thread-cutting machine of the RN-10K by rollers with the necessary profile.

4. Cutting of the rolled billet into parts with an allowance for grinding of the faces.

5. Grinding of faces on a surface grinding machine.

6. Stripping of burrs.

Assembly of the injectors consists of the installation of swirl vane and fastening by tightening the edge of the casing on a press, as is shown on Fig. 7.15a.

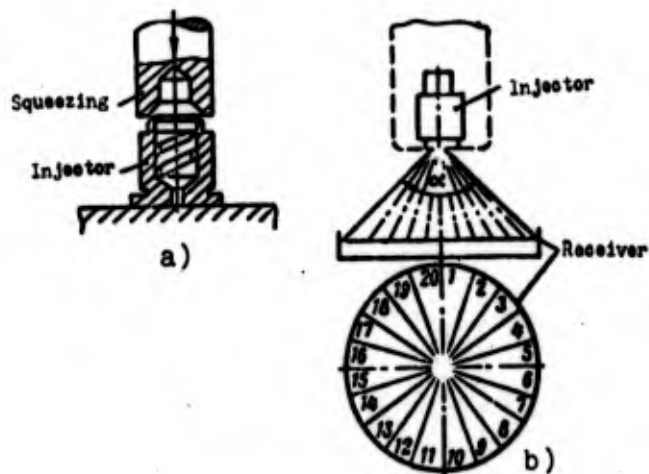

Fig. 7.15. Diagram of the assembly and test of injectors.

All injectors after their manufacture are subjected to thorough control. The geometric dimensions, flow rate per second of liquid, angle of spray, quality of spray, and uniformity of spray are checked. Geometric dimensions are checked by difference gauges or special control automatic machines. Determination of the flow rate per second of liquid is produced on hydraulic pressure test stands, the arrangement and operation of which are described in special literature. Contemporary hydraulic pressure test stands determine the flow rate per second with a total error of less than 1%. If the flow rate per second does not fall in the assigned TU allowances, then the injector is rejected or finished by means of finishing of the inlets. After

finishing the injectors again are checked on a hydraulic pressure test stand. A check of the angle of spray and quality and uniformity of spray is conducted on stands having appropriate devices and instruments. In the simplest form the angle of spray α (Fig. 7.15b) is determined visually on a goniometer. There are apparatuses for the automatic measurement of the angle of spray and photographing of the flame in necessary cases. The uniformity of the spray can be determined by means of flow measurement of liquid through every sector of the receiver, as is depicted below on Fig. 7.15b. There are also more contemporary methods of the measurement of uniformity of the spray.

§ 5. Assembly, Brazing and Welding of Injector Heads

The technological process of the assembly depends on the design of the head and methods of connection of its parts. Most frequently the head is divided into two technological subassemblies.

- 1) injector subassembly, which includes the casing, middle and fire base, injector and certain other parts;
- 2) upper base, pipe with a flange, pipe connection.

These subassemblies are made separately and then are connected by welding.

The most important is the injector subassembly. Taken as base part with assembly of this subassembly is the power ring, into which one of the bases, then injectors, and, finally, the second base are set. The connection of bases with the power ring is carried out by welding or brazing. Injectors are connected with the bases by mainly brazing. As an example let us examine the technological process of the assembly of an injector head of the type shown on Fig. 7.2. In this head the middle base is connected with the power ring by welding and the fire base - by brazing. The assembly of the injector subassembly is started from the welding of the middle base on the installation for the welding of face annular seams.

A diagram of such an installation is shown on Fig. 7.16. The manipulator 2 and column 12 with the cantilever 11 are mounted on bed 1. The power ring 5 of the injector head is set on the support element 4 mounted on face plate 3 of the manipulator. The base 8, which is subjected to welding, is placed into the groove of the power ring and tightened by disk 7 with the help of screw 9, which has on the end ballbearing pivot 10. Welding is produced by a fixed welding head 6 with rotation of the subassembly by the manipulator. Before the welding control rotation of the part is conducted for checking the coincidence of the axis of the welding head with the axis of the seam along the whole circumference. Sometimes before welding the bottoms are clamped at 3-4 points with subsequent stripping for welding. After welding the seam is dressed, and its airtightness is checked. Then an assembly of subassembly for brazing is produced.

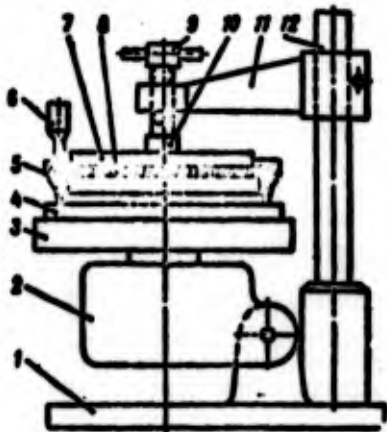

Fig. 7.16. Installation for the welding of annular seams of the FG: 1 - bed, 2 - manipulator; 3 - face plate; 4 - support element; 5 - power ring; 6 - welding head; 7 - disk; 8 - base; 9 - screw; 10 - pivot; 11 - cantilever; 12 - column.

A model diagram of the assembly is shown on Fig. 7.17. At first set of injector the oxidizer is set into the corresponding holes in the middle base. Between each injector and the base a ring of solder is placed. Then the fire base is installed and, finally - injectors of the combustible with rings of solder and ring of solder on oxidizer injectors. For the fixation of injectors from possible displacements during transportation and brazing of the head, the pressing of injectors is conducted, as is shown on Fig. 7.17 (place A) is conducted. The annular clamp with sharpening of the edges at an acute angle cuts into the metal of the base and presses part of the metal into the annular groove on the injector where the ring of solder is placed. The injector is reliably fixed in the base.

In such a way it is possible to fix both the injector of oxidizer and injector of fuel. Rings of solder are made from a tape of solder of the appropriate cross section. With assembly of the subassembly for brazing, one should observe measures of protection from contamination of surfaces of parts prepared for brazing: preserve rings of solder in alcohol, pack the solder and injectors in suede or Kapron gloves, at the location of assembly there should not be dust, etc. Fixation of the fire base is produced by rolling out (see Fig. 7.17, place 5) or another method provided by the design of the subassembly. The assembled subassembly is guided for brazing.

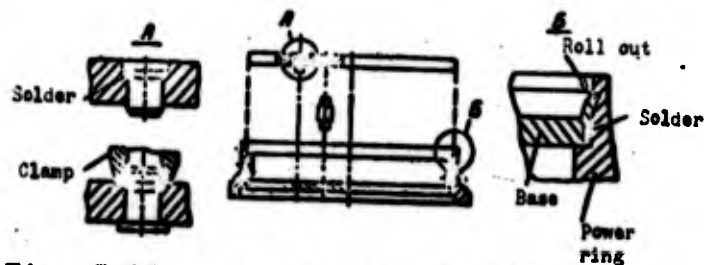

Fig. 7.17. Diagram of the assembly of an injector subassembly.

Brazing of the injector subassembly is carried out in containers loaded into shaft (or of another design) furnace. Characteristic diagrams of the containers are depicted on Fig. 7.18. On diagram a container is depicted for brazing in a medium of protective gas with the addition of a gaseous fluoride flux, which increases the quality of the protective medium. The soldered subassembly 1 is placed into container 3 with a latticed 2. Ammonium fluoride is poured between the lower and latticed bottom of container. The container is closed by cover 9 and placed into a second container 5, which is closed by cover 8. Packing between the cover 8 and container 5 is carried out by a sand seal 7.

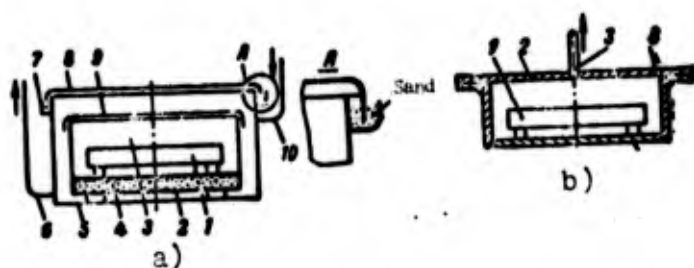

Fig. 7.18. Containers for brazing of injector subassemblies: a) container for brazing in a medium of protective gas; 1 - article; 2 - latticed bottom; 3 - casing of the container; 4 - ammonium fluoride; 5 - external container; 6 - tube of the tap of gas; 7 - sand seal; 8 - cover; 9 - cover of the internal container; 10 - tube of gas feed; b) container for brazing in a vacuum: 1 - article; 2 - cover; 3 - tube to a vacuum pump; 4 - casing of the container.

The quantity of ammonium fluoride is taken at 0.1-0.5 g per liter of volume of the container. With heating the ammonium fluoride disintegrates, forming fluorides which settle on surface of metals to be soldered, preventing their oxidation. At a temperature higher than 800°C the fluorinated film vanishes, and the surface remains clean and free of oxides. The protective gas moves along tube 10 and emerges through tube 6. After turbulent gas generation is completed, tube 6 is covered and in the container an excess pressure of 50-100 mm of water column is created due to resistance in the sand seal. With brazing in a medium of protective gas without the addition of a gaseous fluoride flux, container 3 is not required. The article to be soldered is placed directly into container 5, and brazing is carried out with continuous blowing of the inert gas. Requirements for the cleanness of inert gas and condition of high-quality brazing were discussed earlier in Chapter 6.

On diagram b a container for brazing in a vacuum is depicted. The subassembly 1 to be soldered is placed into container 4, which is hermetically closed by the welded cover 2. Air for the creation of vacuum is drawn off through pipeline 3. Vacuum is maintained in the process of heating, brazing and cooling of the subassembly. After cooling the container is uncovered (the welded seam is ground off),

and the subassembly is extracted. The container is used repeatedly. Each time before the laying of the subassembly the internal surface of the container is subjected to sand-blast purification and degreasing.

After brazing a thorough control of the quality of brazing and check of the airtightness of seams are produced. Figure 7.19 shows a diagram of a device for pneumatic tests of an injector subassembly [2]. The subassembly 3 is placed into the casing 1 of the device and secured by a cover 2. Packing on ends of the power ring is ensured by packings 7, and the outlets of the injectors are muffled by rubber plugs 6. Air under pressure is fed into the annular passage between the casing of the device and test subassembly, and through lateral holes in the power ring it enters into the cavity between the middle and fire bases. The whole device, together with the test subassembly, is put into water, which through holes (not shown on the diagram) fills the space between the fire base and plastic plate 4. Places of nonhermeticity can be revealed visually by bubbles of air passing through water. Observation is conducted through plate 4. After pneumatic tests the subassembly is dried and washed with gasoline.

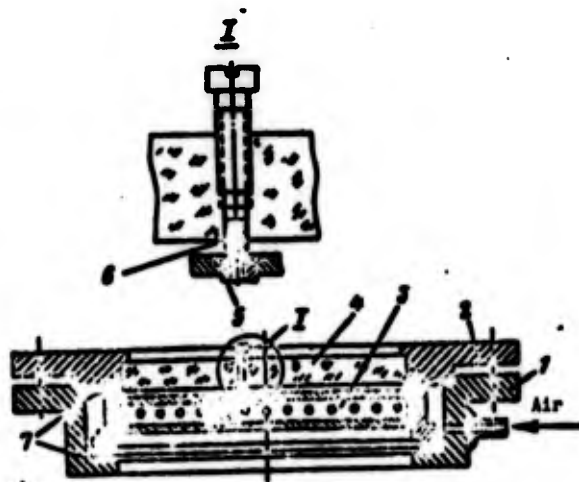

Fig. 7.19. Device for pneumatic tests of a unit of injectors: 1 - casing; 2 - cover; 3 - unit of injectors; 4 - plastic; 5 - injector; 6 - rubber plug; 7 - rubber packings.

The discussed method of tests does not reveal small leakinesses, since the formation of bubbles with a low flow rate of air occurs very slowly. The air, in general, does not penetrate through very small leakinesses. Therefore, if full airtightness is required then for checking other methods of tests are used: air-freon mixture or helium.

The manufacture of a second subassembly of the injector head - upper base with a pipe - presents no difficulty. Preliminarily the flange is welded to the pipe, and then the pipe together with the flange is welded to the base. Welding is carried out in the device, which ensures the central position of the axis of the pipe with respect to the edge of the upper base.

Connection of the injector subassembly with the subassembly "upper base" is produced by welding on an installation of the type depicted in Fig. 7.16, and here the welded seam is formed on the joint of the sphere with the plane. If welding is conducted with a vertical position of the axis of the injector head, as is shown on diagram a of Fig. 7.20, then edges 1 and 2 of the next seam will lie not on the horizontal (diagram b), and a cut can be formed, as was shown on diagram c. For the purpose of improving conditions of formation of the seam, it is expedient to incline the axis of the head (diagram d) up to that position when edges 1 and 2 under electrode will lie on one horizontal (diagram e). The slope of the axis of the head with welding is attained by a turn of the axis of rotation of the face plate of the manipulator.

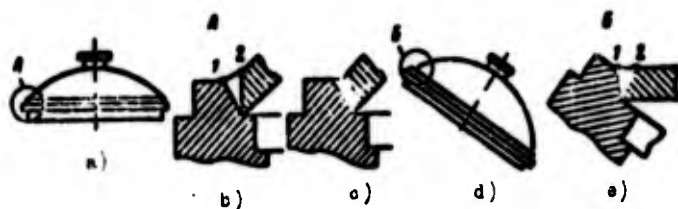

Fig. 7.20. Diagram of welding of the upper base.

After welding the injector head is tested for strength (hydrotest), for tightness of seams (pneumatic test), and then its flow friction is determined by means of a hydraulic pressure test by liquid (in most cases by water). The hydraulic pressure test is carried out on a special stand separately with respect to ducts of the oxidizer and fuel and jointly with respect to both ducts. For this the appropriate pipelines for feeding the liquid and measuring equipment are connected to the head. The flow rate per second of liquid and pressure of liquid at the entrance into the head (or in the appropriate cavity of the head) are measured. Since the outflow of liquid from the injectors occurs freely into the atmosphere, then flow friction of the head is determined by pressure of the liquid at the entrance into the head. Permissible oscillations of flow friction of heads and allowed errors of the measurement of pressure and flow rate of liquid are determined by technical conditions (TU) in tests of heads.

We examined the technological process of manufacture of an injector head in the one basic characteristic construction. But in contemporary engines many other design forms of heads are used. However, in the manufacture of parts of these heads and methods of their assembly there is much in common with the technology of manufacture of the head examined by us.

C H A P T E R 8

ASSEMBLY OF COMBUSTION CHAMBERS

§ 1. Connection of Main Subassemblies

The final obtaining of the combustion chamber as a subassembly of the article occurs in the process of the assembly of its separate subassemblies: central part, nozzle part and injector head.

The character and sequence of the assembly is determined by design of the chamber. If the middle and nozzle cooled part of the chamber are made as one nondetachable subassembly, for example, from a set of profiled tubes, then the assembly of the chamber can be started from the connection of the injector head. If, however, the middle and nozzle cooled part were made separately, then these parts are connected preliminarily. The connection is carried out most frequently by welding. Before welding cutting of the faces is produced for combinable subassemblies, and preparation of edges on lathe or facing machines is made. Here it is very important to select correctly base surfaces for the installation of the subassembly for surfacing, since the ends will determine the relative position of the united subassemblies.

With installation of subassemblies on the machine for surfacing, it is necessary to combine the axis of the subassembly with the axis of rotation of the machine spindle. This will ensure the perpendicularity of the treated end of the axis of the subassembly. With

surfacing measures against the obstruction of channels of cooling of subassemblies by a shaving are taken. If in process of surfacing, in channels of cooling internal burrs are formed, then it is required to clean them. Welding of the middle and nozzle parts is conducted on a special device, which ensures matching of the axes of the subassemblies and matching of edges for welding. Designs of the devices can be different depending upon the design of subassemblies to be joined.

As example Fig. 8.1 shows one of such devices [2]. Welded to disk 1 is housing 2 with boring for installation of the central hollow of column 3. Put onto this column according to the fitting of motion is the bushing 7 carrying the hollow cone 5. In the central part of the column flange 8 with collet 9 fastened to it is secured. The releasing of lobes of the collect is produced by a spring cone 10 moved by nut 11. The middle and nozzle part of the chamber are set on the device, as is shown on the figure by a dashed line. At first the nozzle part is installed and then the middle part, and they are tightened by the annular stop 12 and nut 13. Here the face of the nozzle rests in mount 4 secured to disk 1.

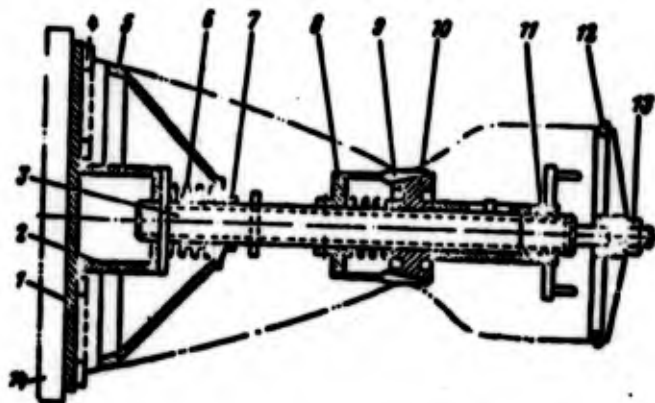

Fig. 8.1. Device for welding of the middle and nozzle parts of the KS:
 1 - disk; 2 - housing; 3 - column;
 4 - mount; 5 - cone; 6 - spring; 7 - bushing; 8 - flange; 9 - collet; 10 - cone; 11 - nut; 12 - stop; 13 - nut; 14 - face plate of manipulator.

Centering of the skirt of the nozzle is ensured by the spring cone 5. Centering of subassemblies in the critical section at the place of the joint and matching of edges for welding is produced by the releasing of the collet 9. Instead of hand screw terminals, by nuts 11 and 13 it is possible to set the pneumatic and hydraulic actuators. Here the design of the device will be changed somewhat. The device together with the secured subassemblies is set on the face plate 14 of the manipulator to ensure rotation during welding.

The installation used for welding and the processes of welding were examined earlier in § 9 of Chapter 5. Connection of the injector head in most cases is produced by welding, although the application of brazing or bolt connection is possible. The connection of the injector head is produced by welding on an installation for the welding of annular seams. The central part and head are mounted on a special welding device, which ensures tightening of the head in the process of welding. The matching of the axis of the central part and axis of the head is attained by the fulfillment of corresponding profile turnings of edges with surfacing of the central part and power ring of the injector head. Furthermore, is required fixation of the head by angle of turn around its axis, since on the head there can be lateral pipe connections or pipes for the lateral feed of the components. These pipes must be located in the position assigned by the drawing with respect to the pipes on the collector of the middle part of the chamber. For angular fixation of the head on the welding device, corresponding support elements - index pins of the position of axes of the pipes or pipe connections both on the head and on the central part of the chamber are provided.

In the welding of annular seams divergence (separation) of welded edges (increase in the clearance between the edges) can be produced at places still not joined by welding due to thermal stresses in the metal. The prevention of this is attained by clamping of the head during welding. The force of the clamp should be 5-15 kgf for every centimeter of length of the seam. It is also possible to produce a preliminary clamp by means of welding at several points along the

circumference of the next seam with subsequent dressing for automatic welding. The speed of rotation of the subassembly with welding should be uniform in accordance with the assigned conditions of welding. The uniformity of movement is attained by removal of gaps in the drive mechanism of the manipulator. The plane of face plate of the manipulator should be perpendicular to the axis of its rotation, and the allowed play of the end must not exceed 0.1-0.2 mm. The play of the face plate along external diameter is allowed to be not more than 0.1 mm.

Bolt connection of the injector head is used considerably rarer. Figure 8.2 shows the injector head joined by bolts of the engine AJ10-138 for the third stage of long-range the ballistic missile "Titan" 3, which is considered more improved than former rockets of this class - "Titan" 1. Engine passed flight tests in October of 1964. Fastened to the head are pipes with flanges for the feed of fuel 1 and oxidizer 5, fuel valve 2 and brackets 3 and 4. Installed on the fire base are partitions with regenerative cooling (cannot be seen on the figure) to increase of the stability of burning.



Fig. 8.2. Injector head of the engine AJ10-138. 1, 5 - flanges; 2 - fuel valve; 3, 4 - brackets.

Merits of bolt bracing of the injector head are the following:

1. Convenience of treatment of the internal surface of wall of the chamber (polishing, application of protective films, etc.).
2. Accessibility of control of places of connection of chamber and injector head.

A deficiency is the certain loading of chamber due to the presence of flanges, bolts and nuts.

§ 2. Installation of Supports and Brackets

The combustion chamber is connected with the frame of engine or with the body of the rocket with the help of supports, which absorb the thrust of the chamber. The following forms of supports, which are schematically depicted on Fig. 8.3 are used:

1. Fixed supports (a).
2. Spherical or Cardan support in the center of the head of the chamber (b).
3. Lateral journals located near the center of gravity of the chamber (c).

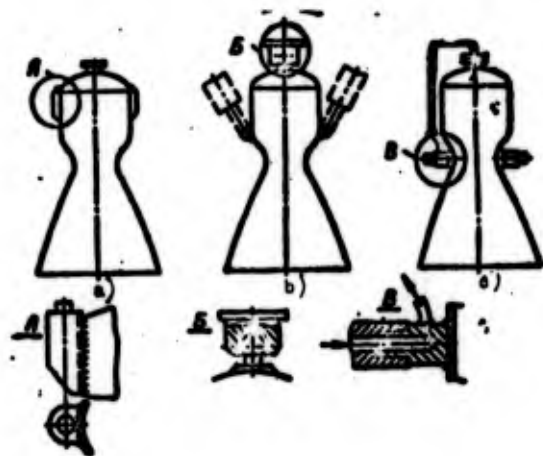

Fig. 8.3. Diagram of supports of combustion chambers.

Fixed supports are used with rigid installation of the chambers. Sometimes for controlling the position of the axis of the chamber and for the uniformity of tightening in the process of the connection of the chamber to the frame, these supports have corresponding mobile parts. The quantity of supports on each chamber is not less than three. The supports are connected with the power ring of the head and with the jacket of the central part with the help of welding in a welding device. The device should fix the support in the position assigned by the drawing with respect to the axis of the chamber, with respect to the angular location and in height. In the same device it is possible to set the brackets specified by the drawing, pipe connection and other parts. The welded seams are located over the

whole contour of adjoining of the support to the chamber and are inconvenient for welding in the device. Therefore, in the fittings it is expedient only to clamp supports by welding at several places and produce welding over the whole contour of adjoining of supports with the help of another device, which allows turning the chamber in the position convenient for welding. If by welding the assigned accuracy of the position of supports is not ensured, then after welding machining of the supports is produced with basing of the chamber on its geometric axis. Along places of treatment corresponding allowances are provided.

Spherical, or Cardan, supports are used when it is required to deflect the axis of the chamber with respect to the axis of the rocket by an angle of 5° - 10° for the purpose of controlling the thrust vector of the engine (flight control of the rocket). The support is located in the center of head, and from lateral displacements the chamber is held by rods fastened to brackets on the jacket of the central part of the chamber, as is schematically shown on Fig. 8.3b.

Brackets for lateral rods are welded to the jacket of the chamber with the help of devices fixing brackets in the assigned positions. The spherical support is fastened to the upper reinforced base of the injector head by welding or by bolts.

With rocking of the chamber linear lateral movements of its parts are proportional to the distance from the spherical support (center of oscillation). The greatest movements are at the section of the nozzle, and the head of chamber is deflected by a small magnitude. Taking this circumstance into account, joints of pipelines for the feed of fuel and oxidizer are located as near as possible to the center of oscillation of the chamber. Sections of pipelines from these joints to collectors on the chamber are fastened to the jacket of the chamber, and all pipelines up to these joints are fastened to the frame of the engine. At places of the greatest bends of pipelines, near joints flexible pipelines are installed. For fastening pipelines to the jacket of the chamber, corresponding subassemblies are welded.

Lateral journals are installed instead of spherical supports for rocking of the chamber in the process of flight control of the rocket. The advantage of the support of the chamber on lateral journals as compared to the Cardan support consists in the fact that the moment inertia with rocking of chamber decreases, which facilitates control of the thrust vector. Since the center of rotation of the chamber is approximately near the critical section, then places of joint of the pipelines and their flexible sections should be approximately near the critical section. In order to avoid the installation of flexible pipelines, it is possible to feed the fuel and oxidizer through hollow journals, as is done in the English engines of the "Gamma" type.

The journals are welded to the reinforced part of the jacket of the chamber in the welding device. The basic requirement here is to maintain coaxiality of both journals, since to ensure oscillation of the chamber the axes of the journals must be on one line. If with welding it is not possible to attain the required coaxiality due to postwelding deformations, then after welding machining of the journals is produced with basing on the true axis of chamber.

§ 3. Connection of nozzle parts.

Nozzles with a large expansion ratio are frequently made with attachments on the lower wide part without regenerative cooling. Attachments are fastened to the basic nozzle with the help of welding, brazing or bolts. With the installation of the attachments is required an exact coincidence of the axis of the basic nozzle and axis of attachment, since its position is governed by the direction of the thrust vector of the chamber. Difficulties appear also in connection with the fact that the attachment possesses low rigidity and has large dimensions as compared to the basic chamber.

Attachments of nozzles operate in stressed conditions at high temperature. Therefore, they are made of heat-resistant materials or alloys. A covering of the internal surface to the fused protective layer is also used. With the connection of the attachment by welding, one should consider weldability of metals of the basic nozzle and

attachment. If these metals are not welded to each other, then it is possible to use an intermediate ring from such a metal or alloy with which both the metal of the attachment and metal of the basic nozzle are welded well.

Sometimes the nozzles are made deflecting with respect to the central part of the chamber. This is done to control the thrust vector with a fixed chamber, which decreases the inertial forces.

Figure 8.4a shows one of the designs of a deflecting nozzle. Welded to nozzle 1 is ring of rigidity 2 with two brackets 3. On ends of brackets there are journals, which enter into bearings 4 mounted on ring 6. Such fastening permits the nozzle to be deflected in one plane. Deflection in another plane, located at an angle of 90° to the first, is carried out by gimbal thrust pad of ring 6 on bearings 5 mounted on frame 9, which is rigidly joined to the fixed chamber.

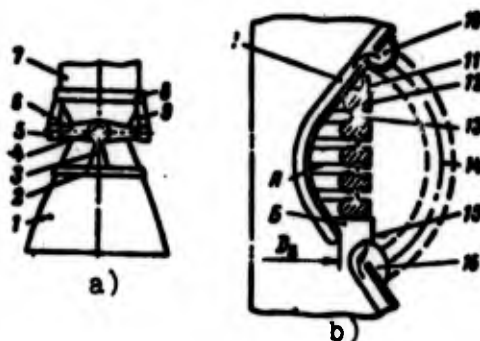

Fig. 8.4. Fastenings of the deflecting nozzle:
 1 - nozzle; 2 - power ring;
 3 - bracket; 4, 5 - bearings; 6 - ring; 7 - chamber;
 8 - ring of rigidity; 9 - frame; 10 - collector;
 11, 15 - fastening; 12 - ring of rigidity;
 13 - bellows; 14 - flexible hose; 16 - collector.

The packing between the fixed chamber and deflecting nozzle is attained by the installation of bellows (see Fig. 8.4b). The bellows are fastened to the chamber and nozzle by connections 11 and 15. To prevent great deformations of the bellows in a radial direction under the action of the pressure of gases in the chamber getting through slot B into cavity A, rings of rigidity 12 are installed into bends of the bellows 13. However, these rings do not prevent

axial deformations of the bellows with deflection of the nozzle. Liquid coolant from the interjacket space of the nozzle enters into collector 16, along flexible hoses 14 will overflow into collector 10 and then heads into the interjacket space of the chamber 7.

The connection of nozzle is started from the installation of the bellows (together with rings of rigidity) on the fixed part of the chamber. With respect to conditions of assembly, it is necessary that the external diameter D_H of the edge of the section of the fixed part of the nozzle be less than the internal diameter of the bellows. Then the Cardan ring 6 and nozzle part are installed. Matching of the axis of the nozzle with the axis of the chamber is attained by adjustment of bearings 4 and 5. Assembly is completed by installation of flexible pipelines 14. After assembly the kinematics of deflection of the nozzle by the given magnitude in the first and second planes is checked.

Other designs of deflecting nozzles with other packings are used, and the technology of assembly of these will be different developed in reference to these designs.

§ 4. Protective Coverings

For the protection of walls of the combustion chamber and nozzle from the action of high temperature, in recent time ever more frequently on the internal surfaces of the walls protective coverings of various kinds began to be applied. Basically these coverings can be divided into four classes.

1. Films from refractory metals and alloys - molybdenum, tantalum, columbium, beryllium and others.
2. Ceramic refractory protective films.
3. Films from plastics - teflon, polyethylene, polystyrene and others.

4. Combined coverings.

Films from refractory metals and alloys and ceramic films protect the surface of the wall from the direct effect of hot gases and reflect part of the radiant energy. Without these films the surface of the wall could be fused.

Films from plastics protect the wall according to another principle: under the action of high temperature they start gradually to be carbonized, thereby absorbing the energy of heat flow. This process is called ablation, and the method of protection is ablative cooling or ablative protection.

Ablative protection is quite effective, and with its application in many cases it is possible to reject regenerative cooling of the walls by a liquid. The application of ablative protection instead of regenerative cooling is especially expedient for engines of multiple switching on with prolonged interruptions during flight in space, since chambers with ablative protection have lower thermal inertia (there is no liquid in the interjacket space).

Protective coverings are applied by metallizing, plasma spraying, galvanic deposition or other methods. The application of protective coverings by metallizing is produced in the same way as with the application of solder, which was discussed in § 6, Chapter 6. Only instead of solder, the metal or alloy necessary for covering is atomized. A layer of ceramics or plastic is applied by special apparatuses (similar to metal spray guns), mounted on installations for spraying, as is depicted in Fig. 6.4. With spraying it is very important to provide the assigned thickness of the layer evenly over the entire surface or with the necessary increase in thickness on certain sections. Uniformity of thickness of the layer is attained by maintaining the following constants: operating conditions spraying apparatus, the distance from the section of the nozzle of the atomizing head to the surface on which is applied the spraying, longitudinal feed and relative rate of movement of the spraying cone (with respect to the surface on which spraying is produced).

With plasma spraying the configuration of the apparatus is basically the same as that with metallizing. If the process occurs in a vacuum, then the whole installation is placed in a vacuum chamber, just as in electron-beam welding. With the operation of powerful plasma-arc burners (about 50 kW) a noise up to 90 dB, ultraviolet radiation with dense energy flow and ionizing radiation are observed. Therefore, it is necessary to use the appropriate means of protection of maintenance personnel: protective screens, spectacles, forced ventilation, etc. Very often the shielding of the wall of the chamber or nozzle consists of several layers, each of which has its purpose. Thus, refractory metals at a temperature higher than 1900°C are inclined to oxidation, which sharply lowers their reflectance. Therefore, for the protection from oxidation, on the surface of the metal a thin protective film of a material stable to oxidation by plasma spraying, deposition of vapors or other method is applied.

For ceramic protective coverings of ceramics with a base of ZrO_2 (at a temperature not higher than 2500°C) and ThO_2 and HfO_2 (at a temperature higher than 2500°C) is used. To increase the emissivity Cr_2O_3 is added. Heat shielding coverings can be used also for ablative protection. For example porous ceramics is impregnated with an ablative material. Thermal protection can be nonuniform along the whole surface. For example, the French engine "Veksin" [Translator's note: this name is unverified] has a combustion chamber with protection of the nozzle by a layer of zirconium, and protection of the nozzle throat is carried out by an insert of graphite. There are examples of other combinations.

§ 5. Tests and Drying of the Chamber

The combustion chamber made is subjected to hydro tests for strength, pneumatic tests for airtightness and a hydraulic pressure test for the determination of flow friction of ducts of fuel and oxidizer.

In hydrotests inside cavities indicated in TU for tests (for example, into the interjacket space or into the cavity of the chamber) 0.3-1% aqueous solution of bichromate is poured: at all outlets except one plugs are installed and inside the cavity the necessary pressure of the liquid is created. The magnitude of the pressure, time of exposure and permissible elastic deformations are assigned by the TU for the tests.

Similarly pneumatic tests are conducted, but instead of liquid inside the cavities air or another gas under an assigned pressure is fed. Nonhermeticity is determined with the help of a soap emulsion or other improved methods. A hydraulic pressure test of the chamber is conducted usually with water on special test stands. The flow rate per second of the liquid and magnitude of flow friction along each duct are assigned by the TU. Figure 8.5 gives a schematic diagram of a test stand for the hydrostatic test of chambers [2]. The chamber 2 to be tested is set above reservoir 1 and joined to it are feeder tubes. Pressure of the liquid is created by pump 14 driven by an electric motor 15. The liquid is sucked by the pump from the reservoir through the receiving filter 16. With the hydraulic pressure test along the duct of the oxidizer slide valve 10 is opened, and slide valve 11 is closed. The flow rate per second of liquid is measured by a washer (or nozzle) 6 and differential manometer 7. The inlet pressure in the injector head and in the cavity of the head is measured by manometers 4. The flow rate and pressure are regulated by throttle 5. To dampen the fluid flow, at the input a pipe 3 is installed. With passage along the cavity of fuel slide valve 10 is closed, and slide valve 11 is opened. The flow rate is measured by washer 9 and differential manometer 8 and the pressure by manometer 4 (on the right on the figure). The hydraulic pressure test can be conducted simultaneously on both ducts with open slide valves 10 and 11.

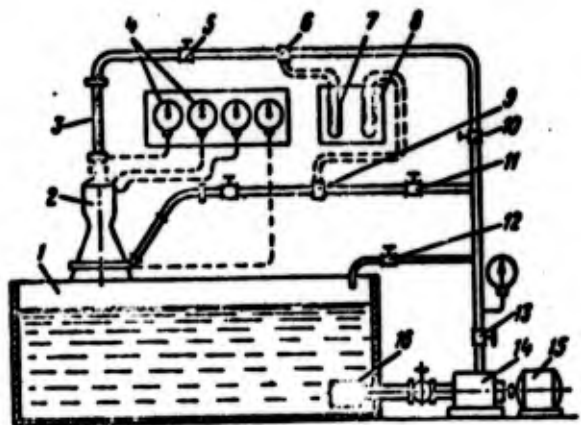

Fig. 8.5. Diagram of a test stand for the hydraulic pressure test of combustion chambers: 1 - reservoir; 2 - chamber to be tested; 3 - pipe; 4 - manometers; 5 - throttle; 6, 9 - measuring devices; 7, 8 - differential manometers; 10, 11, 12, 13 - slide valves; 14 - pump; 15 - electric motor; 16 - filter.

After the hydraulic pressure test the internal cavities of the chamber are ventilated by compressed air for the removal of residues of liquid, and drying for the final removal of moisture is conducted. Drying is conducted in special drying furnaces in the flow of hot air. The duration of drying is set by experimental means. Drying by hot air does not always give good results. Drying in vacuum furnaces is more effective. In necessary cases the internal cavity of the KS is degreased by a special composition.

P A R T I I

THE MANUFACTURE OF FRAMES AND PIPELINES

CHAPTER 9

THE MANUFACTURE OF FRAMES

§ 1. Design Configuration and Technical Requirements

The frame of an engine has the following basic assignments:

1. To connect all units of the engine into a single technological group convenient for the transportation and installation of the engine on the rocket.

2. To receive thrust of the combustion chambers making up the engine and transmit this force to the body of the rocket, having evenly distributed it along the joint plane or along the joint subassemblies.

3. To establish the principal axis of the engine in an assigned position with respect to the axis of the rocket.

Design of the frame is determined by the quantity of chambers making up the engine, the method of fastening the chambers (fixed, on a spherical support or on lateral journals), the quantity of turbopump units (TNA) in the engine (a common turbopump unit for all chambers, or each chamber has its own turbopump unit), quantity and dimensions of control valves and other factors. Therefore, frames in terms of their design are very diverse. Single-chamber engines of recent designs are made, in general, without frames. The function

of frame in these engines is fulfilled somewhat by the reinforced combustion chamber, to which the turbopump unit, gas generator, valves and all other units are mounted. However, with the arrangement from such single-chamber engines of propulsion systems of great thrust, general frames are required.

We will examine frames of average dimensions making up the design of the engine, as, for example, the frame of the French engine C-2 or frame of the American propulsion system of the third stage of the rocket "Titan" 3.

Let us examine some conditional simplified frame depicted on Fig. 9.1. It consists of power struts 1, middle flange 2, struts 3 and lower flange 4. To the body of the rocket the frame is mounted by support pads 7. Knuckle bearings of combustion chambers are set in supports 6. For the fastening of controlling hydraulic drives on the lower flange, brackets 5 are welded. The frame is made of pipes united by welding.

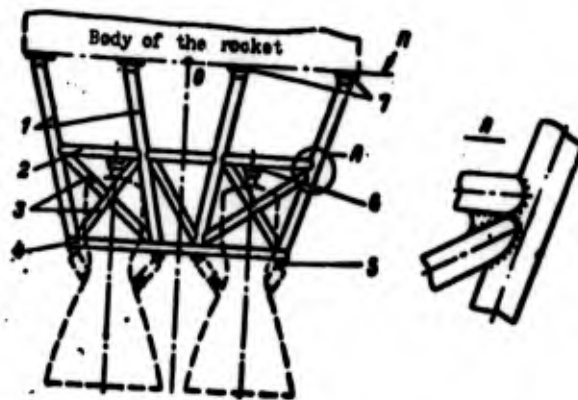

Fig. 9.1. Diagram of a simplified conditional frame of the engine:
1 - power struts; 2 - middle flanges;
3 - diagonal braces; 4 - lower flanges; 5 - bracket; 6 - central support; 7 - support.

Frames have the following technical requirements:

1. The position of centers of supports Γ with respect to the axis of the frame should be exact, so that the axis of the engine occupies the assigned position with respect to the axis of the rocket.

2. Upper planes of supports Γ must be in the joint plane Π (plane of disassembling), so that the thrust of the engine is distributed evenly along all supports.

3. Places of fastening of supports of the combustion chambers must be in an assigned position with respect to supports Γ of the frame (places of mounting of the frame to rocket).

4. Rods of frame must be rectilinear to avoid longitudinal sag under the action of compressing forces.

All these requirements in industrial conditions cannot be carried out absolutely exactly. Therefore, proceeding from calculations of strength and conditions of centering, the maximum permissible deviations (error) from nominal values are established. These admissible deviations are usually small, which complicates the technological process of the manufacture of frames. In certain designs for the purpose of the simplification of technology, adjustable supports are provided. For example, the knuckle bearing of the engine J-2 has a device regulating the position of the center of the support to ensure the coaxiality of the engine and rocket in the process of installation.

The technological process of the manufacture of welded frames consists of the following basic stages:

1. Treatment of the parts - billet of pipes, shaping of ends, treatment of supports, brackets, knee-plates and other parts.

2. Assembly and welding of subassemblies.

3. General assembly and welding of the frame.
4. Machining of joint places.
5. Control of geometric dimensions and tests.

§ 2. Treatment of Parts of Frames

Frames basically consist of segments of pipes, supports, knee-plates and brackets. Pipes of the required diameter and thickness of walls are cut on measuring billets, and then the ends of them are finished to ensure the adjoining of one pipe to the other or to supports for welding. The form of the shaping of the ends depends on the angle between axes of the combinable pipes and their diameters.

Figure 9.2 shows model forms of the working out of ends of pipes. Diagram a gives the form of working out with the connection of pipes at a right angle. Such working out can be obtained by milling. The radius of the milling cutter should be equal to radius R of the adjoining pipe. Diagram b shows the form of shaping with the connection of pipes at acute angle α . To obtain shaping, it is necessary with milling to set the billets at the same angle α with respect to the axis of the milling cutter. Diagram c shows the connection of the end of the pipe with the support. For the shaping for such a connection, the end of pipe should be deposited in a stamp and then by a disk milling cutter undercut a groove under the shank of the support. After the shaping, the ends are cleaned for welding. Methods of dressing are analogous to those discussed earlier in § 8 of Chapter 5.

The supports and brackets are prepared by machining (milling) from forgings or castings. Only places of the connection of supports with other parts are subjected to machining. The remaining surfaces are not machined.

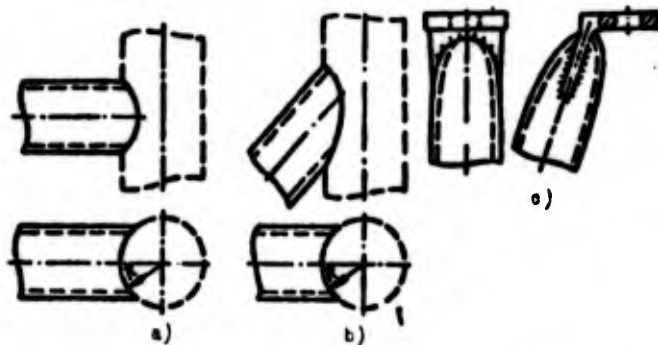

Fig. 9.2. Forms of shaping of ends of pipes.

§ 3. Assembly and Welding of Frames

The assembly and welding of frames can be produced both from separate parts and from parts preliminarily united into subassemblies. Simple frames are usually gathered from separate parts. It is expedient to divide complex frames into simple subassemblies and weld them separately. This simplifies and makes the technology cheaper and also reduces cycle of assembly of the frame. For example, in the frame depicted on Fig. 9.1, it is possible to separate into separate parts the lower flange 4 and crosspieces from struts 3. Devices for the assembly and welding of subassemblies are usually simple.

Figure 9.3 gives a diagram of the device for the welding of a crosspiece. It consists of a base 1, two braces 2 and a turning frame 5 with stops 6. The welded subassembly consists of one long pipe 9 and two short pipes 7 and 8. The pipes are set into beds 10 stops 6 and are secured by clamps (on diagram these are conditionally not shown). For the convenience of welding the frame 5 together with the secured subassembly to be welded can turn around the axis 0-0. Fixation of the angle of rotation is produced by stopper 3 clamping the axle 4. Devices for the general assembly and welding of frames for the most part are complex, since stops for the retention of elements of the frame in the assigned position are located not in a plane but in three-dimensional space.

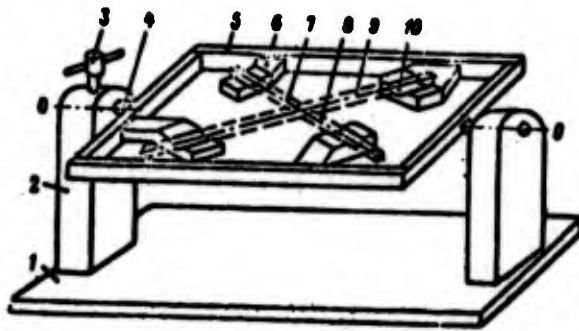

Fig. 9.3. Device for the welding of a crosspiece: 1 - base; 2 - brace; 3 - stopper; 4 - axle; 5 - frame; 6 - stops; 7, 8, 9 - elements to be welded; 10 - bed.

Furthermore, these stops must be designed in such a way so as not to hinder the removal of the welded frame from the device. For the convenience of welding the device should allow turning the frame around a central axis and sometimes still incline this axis at different angles to the horizon. For an illustration Fig. 9.4 gives a diagram of the device for the general assembly and welding of the frame depicted on Fig. 9.1. It consists of a base 1, brace 5 with bearing 6, disk 7 and basket 8. Elements of the frame to be welded are set in stops secured on basket (stops are not shown on the diagram in order not to complicate the drawing). Besides turning around the axis 0-0, the device allows inclining this axis of rotation at the necessary angle α to the horizon.

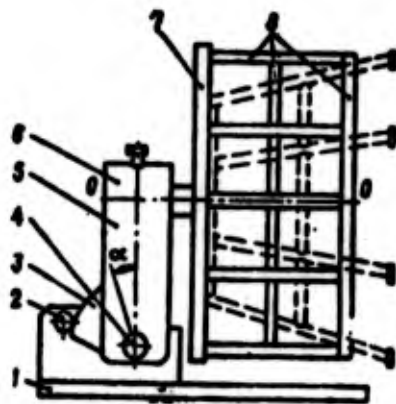

Fig. 9.4. Diagram of a device for the welding of frames: 1 - base; 2 - turn mechanism; 3 - sector; 4 - axle; 5 - brace; 6 - bearing; 7 - disk; 8 - basket.

With inclination brace 5 together with the disk and basket turns about axis 4 with the help of mechanism 2 linked with sector 3.

Welding of the frame is conjugate with local heating of its elements and subsequent cooling, which generates welding deformations. These deformations change the geometry of the frame assigned by the stops. In order to hold the joint points of the frame from shifts caused by welding deformations, powerful stops and a rigid basket are required, which makes a device heavier. Furthermore, it is not always necessary to hold the elements from shifts, since in this case forces generating the shifts will act on the not fully shaped and hot welded seams, causing in them breaks and cracks.

A decrease in welding deformations can be attained by the rational order of superposition of the welded seams, which is found by experimental means and is recorded in technological documentation. But even with the exhausted technological process after welding in the frame rigidly secured in the device internal stresses remain. With releasing of the frame from stops of the device, these internal stresses are redistributed, which causes a shift in joint places and disturbance of the geometric dimensions assigned by the drawing. If these shifts exceed those allowed by technical conditions and are systematically repeated at the same places, then an appropriate correction of the position of stops in the welding device is conducted. They are set in such a position in order to displace the needed joint point from its nominal position in a direction reverse to the direction of the postwelding shift by a magnitude equal to the magnitude of the shift.

Consequently, welding will be conducted with fixed distortion of geometric dimensions of the frame. But after releasing from the effect of the device the frame will take dimensions assigned by the drawing.

Redistribution of internal stresses in elements of the frame and, consequently, a change in dimensions occur not only at the time of releasing from the stops, but also after that in a free state of the

frame during a rather long time — from several days to a month and more. This process is called aging. It is possible to reduce the duration of the process of aging by means of exposing the frame in a chamber with raised temperature (artificial aging) or other heat treatment.

§ 4. Machining of Joint Places

Postwelding deformations of the frame do not permit maintaining the necessary accuracy of the position of places of joining the frame with the body of the rocket and places of connection of the combustion chambers. Therefore, in the design of the engine devices for controlling the position of the support are provided. If there are no such devices, then the joint places are mechanically treated for the purpose of achievement of the assigned accuracy. In the frame, shown on Fig. 9.1, with stiffening to the body of the rocket, it is necessary to treat the following:

1. Supports 7 in such a manner so that their upper planes lay in the joint plane Π .
2. Holes in supports 7 — the position of these holes and their diameter must correspond to the position and diameter of holes in the support ring of the body of the rocket.
3. Supports 6 — centers of these supports must be at an identical distance from the principal axis of the frame.

Selection of the method of treatment of supports 7 in plane Π depends on the magnitude of postwelding deformations. If they are small, then it is possible to use grinding. With large deformations, before grinding it is expedient to introduce the operation of milling. The appropriate allowance for the machining of supports is provided in the manufacture of supports placed on the assembly and welding of the frame.

The device for milling and grinding of the supports can consist of one. In the designing of the device, it is very important to select correctly the base surfaces of the frame. For the frame examined by us, as bases with treatment of supports in plane Π it is possible to take supports 6, having provided for the possibility of adjusting their position with respect to the plane of treatment. It can appear that the untreated plane Π of supports 7 will be greatly inclined with respect to the plane of movement of the tool, which will lead with its treatment to a nonuniform removal of the metal. Due to this irregularity of treatment from one side of the frame pads of supports 7 will be thinner, and from the other side - thicker. In order to avoid this, it follows by adjustment of the position of supports 6 to level the plane Π so that the allowance for treatment is distributed evenly.

Installation of the frame on supports 6 can appear insufficiently rigid, in consequence of which with treatment undesirable vibrations of struts 1 can appear. In these cases one should set in the device the supplied supports to the struts. In this case it is necessary to see to it that these supplied supports do not effect with installation the basic supports (supports 6) and do not before the struts.

Methods of basing and fastening of the frame with drilling, counterboring or reaming of fastening holes in pads of supports 7 are the same as those in the treatment of plane Π .

With the small program manufacturing frames, operations of the treatment of plane Π and fastening holes can be combined and fulfilled in one device.

Places of fastening of combustion chambers should be treated with basing of the frame on plane Π and on fastening holes in supports 7.

C H A P T E R 10

MANUFACTURE AND TEST OF RIGID PIPELINES

§ 1. Design of Pipelines and Their Connections

Pipelines used in liquid-propellant rocket engines are very diverse in configuration, dimensions (diameter, length) and in the method of connection with the units and with each other. They serve for feeding liquid components to pumps and from pumps to the combustion chambers, for feeding gas to the turbine, for tapping exhaust gases, for feeding controlling liquid or gas to actuators and for other purposes. Pipelines and especially their connections must be light and durable and hermetic and reliable.

The following forms of connections of pipelines (Fig. 10.1) are used:

- a) joint welding;
- b) brazing in a telescopic connection;
- c) brazing with external sleeve (segment of the pipe but on the ends);
- d) tightening of the rolled end of pipe between the nipple and pipe connection with the help of a sleeve nut;

e) tightening of the nipple;

f) with help of flanges.

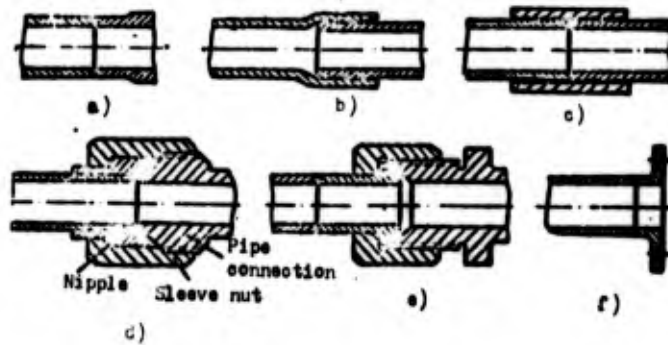

Fig. 10.1 Methods of the connection of pipelines: a) joint welding; b) brazing in a telescopic connection; c) brazing with external sleeve; d) tightening of the rolled end; e) tightening of nipple; f) on flanges.

Connections a, b, and c are nondetachable.

Connections d and e are used basically for small diameters.

The majority of pipelines are prepared from seamless standard pipes by the method of bending and shaping of the ends.

Pipelines of large diameters or very complex configuration are prepared from sheet material. The manufacture of pipelines of complex configuration is possible also by the method of deposition or spraying of metal and also the method of winding.

§ 2. Manufacture of Pipelines from Seamless Pipes

In the manufacture of pipelines from standard seamless pipes the following route procedure is used:

1. Cutting of pipes on measuring billets.
2. Purification of the surface.
3. Bending of the pipes.
4. Shaping of the ends.
5. Connection of the fittings.
6. Dressing after welding or brazing.
7. Test for strength and airtightness, hydraulic pressure test.
8. Washing, drying and sealing of ready pipelines.

To determine the length of the billet of the pipeline, which has bends and rectilinear sections, scanning of the axial line of the pipeline is produced. The length of the billet L is determined by the formula

$$L = \sum l_i + \sum R_i \phi_i$$

where $\sum l_i$ - sum of lengths of the rectilinear sections; $\sum R_i \phi_i$ - sum of lengths curvilinear sections; R_i - radius of curvature of the axial line of the pipeline; ϕ_i - angle of bend in radians.

In determination of the length of the billet sections for welding of nipples or pipe connections and allowance for treatment of the faces are considered.

Cutting of the billet of pipes. For the cutting of billet a special pipe cutter machines of the type S-246M (plant named after Kalinin) or mechanical hacksaws are used. With large scale of the production cutting in stamps (diameter of pipes not more than 50 mm) is used. With cutting by mechanical methods, on the end of the pipe

burrs remain which should be cleaned. Cutting without burrs can be carried out by the anode-mechanical method, the schematic diagram of which is shown on Fig. 10.2.

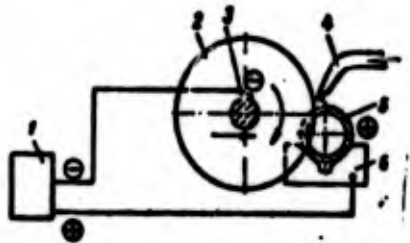

Fig. 10.2. Diagram of cutting of pipes by the anode-mechanical method: 1 - source of electrical current; 2 - cutting disk; 3 - sliding contact; 4 - electrolyte feed; 5 - billet; 6 - support.

The billet 5 to be cut is set into the knife edge 6 of the machine. The revolving cutting disk 2 will cut into the billet. Working fluid (electrolyte) is fed into the zone of cutting through nozzle 4. Treatment is conducted with the feeding of direct electrical current from source 1. The positive pole is connected to the part to be machined and the negative - through the sliding 3 to the cutting disk. As a result of the action of electrical current in the electrolyte, on the surface of the metal an anode film, which departs by the revolving disk will be formed. The working fluid is an aqueous solution of water glass with a small addition of oil for the prevention of corrosion of parts of the machine. The flow rate of the working fluid is 5-10 l/min. The cutting disk is made of soft steel with thickness of 0.5-2 mm. The peripheral velocity of the disk is 7-15 m/s. The d-c voltage is 20-30 V. For anode-mechanical cutting machines of the type of AMO-31, AMO-32 and others are used.

Cleaning of the surface of the pipes is connected by chemical, hydroabrasive or ultrasonic methods.

Chemical cleaning consists of degreasing, washing, etching and neutralization.

Hydroabrasive cleaning is carried out by a stream of abrasive suspension (mixture of small abrasive with liquid). The suspension is fed by a pump or injector. After hydroabrasive purification the pipelines are washed by an aqueous solution of bichromate (0.2%).

The method of ultrasonic purification was described by us earlier in § 8 of Chapter 5. For the cleaning of pipes ultrasonic units of the type UZA-2 are used, and they consist of a bath of the type UZV-4 with four magnetostrictive radiators PMS-8 built into its bottom, mechanisms of loading and unloading and a pump installation for pumping the washing liquid (water or kerosene). Magnetostrictive radiators obtain the feeding from the high-frequency generator UZG-10.

Bending of the pipes is conducted on tube-bending machines or in special devices. With the bending of the pipe in its wall, located on the external side of the bending place, there appear tensile stresses, and in wall on the internal side - compression stresses. As a result of the interaction of these stresses the pipe is flattened, as is shown on Fig. 103a. The magnitude of flattening depends on the ratio of the radius of the bend to the diameter of the pipe and on the thickness of the wall of the pipe.

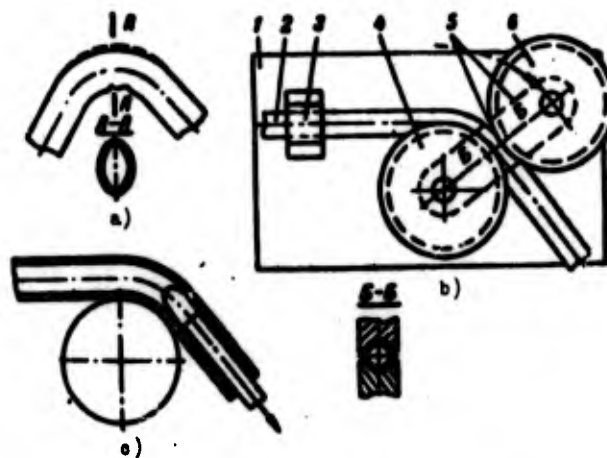

Fig. 10.3. Diagrams of the bending of pipes: 1 - table of machine; 2 - billet of pipe; 3 - blankholder; 4 - roller; 5 - guide; 6 - rolling roller.

Furthermore, under the action of compression stresses the thin wall of the pipe loses stability, as a result of which folds on the internal side of the pipe elbow will be formed. In practice the minimum radii of bending of pipes at which folds do not appear are established and the magnitude of flattening is in permissible limits. Values of minimum radii of bending are given in reference books. In the first approximation it is possible to take the radius of bending of not less than 2.5 diameters (external) of the pipe.

To prevent flattening of the pipe, bending is conducted in shaped rollers, as was shown on Fig. 10.3b. The rollers encircle the pipe and prevent flattening by the backwater on both lateral faces. The radius of the groove of the rollers is made according to maximum external dimension of the bent pipe. According to such principle tube-bending machines are built. The pipe to be bent is secured on Table 1 by clamp 3. The axle of the molding roller 4 is stationary with respect to table 1. Roller 6 is secured on guide 5 (shown by the dashed line), the axis of rotation of which coincides with the axis of rotation of roller 4.

With rotation of the guide clockwise roller 6 is rolled along the molding roller 4 and bends the pipe. The radius of bending is determined by the radius of the molding roller.

With such a method of bending of the wall, the pipes are held from external side, which is sufficient for the prevention of flattening of pipes of small diameter – less than 16 mm. For the bending of pipes with a diameter of more than 16 mm support of the wall on the internal side is required by means of filling the pipe with loose (for example, sand) or a viscous substance or liquid.

Support of the wall of the pipe on the internal side by a sliding mandrel, called a mandrel is also used.

With the bending of pipes from aluminum alloys, as the filler paraffin is usually used. Bending of steel pipes is produced with the feed inside the pipe of an emulsion under a pressure of about 20 MN/m^2 (200 at).

A diagram of bending with the application of a mandrel is shown on Fig. 10.3c. Mandrel is set inside the pipe in such a way so that its rounded end touches the external wall of the bent pipe. Forward motion of the mandrel is kinematically connected with the turn of the guide carrying the rolling roller. With bending of the pipe the mandrel gradually shifts. Consequently, molding of the pipe occurs on the rigid travelling mandrel, which prevents flattening of the pipe. For the purpose of improving conditions of deformation of the wall of the pipe with bending, preheating of the zone of bending, for example, by currents of high frequency, is used. With bending of the pipe in one plane the control of configuration is conducted by flat patterns. With complex bending in several planes control mold lofts are used. As example Fig. 10.4 shows a diagram of one such mold loft.

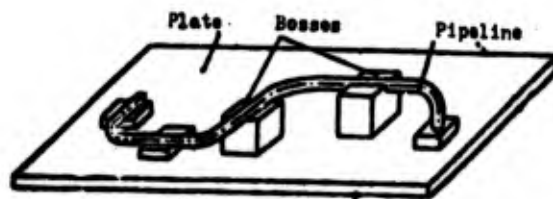

Fig. 10.4. Mold loft for checking the configuration of the pipeline.

The shaping of ends of pipes is fulfilled by two methods: by a revolving mandrel and extension by a punch.

The revolving mandrel (Fig. 10.5a) gradually rolls the end of the pipe by rollers inserted into grooves of its cone part. The pipe is held by a clamp. With rolling the mandrel moves into the pipe.

The cone punch (Fig. 10.5b) without rotation is moved into the pipe and produces molding of the end. The pipe is held by a clamp. Both with the first and second method extension of the material of the pipe occurs due to plastic deformations. The magnitude of the

extension is equal to the difference of lengths in circumference of the initial pipe by diameter d and circumference of the greatest extension by diameter D (Fig. 10.5c).

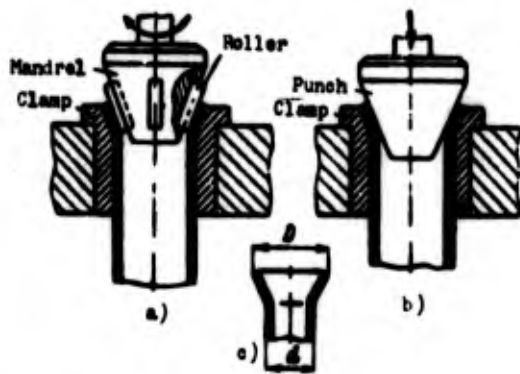

Fig. 10.5. Diagrams of rolling out of ends of pipes.

The relative extension in percent is

$$\epsilon_p = \frac{\pi D - \pi d}{\pi d} \cdot 100 = \left(\frac{D}{d} - 1 \right) \cdot 100(\%)$$

If the magnitude of relative extension exceeds the lower limit of elongation per unit length of the material of the pipe, then destruction of the rolled edge will occur. This should be considered in the development of the technological process.

In the case when it is required to obtain the magnitude of the extension larger than is allowed by the plasticity of the material, rolling should be fulfilled not in one but in two or three operations with intermediate annealing for the removal of cold hardening of the metal.

The shaping of ends of pipes by a rigid punch is simpler and more productive. However, conditions of the extension are considerably worse than those with the first method. Force is applied simultaneously over the whole section of the pipe, and in the presence of local

thinnings of the wall, uneven edges and other defects a local concentration of stresses occurs. This causes breaks in edges considerably earlier than that which follows from calculations under the condition of uniform deformation of the metal.

With shaping according to the first method the extension of the metal occurs gradually and more evenly. Therefore, by rolling greater extension can be obtained than with a rigid punch.

Connection of fittings. Nipples, pipe connections and other fittings are joined to pipelines most frequently by welding or brazing. The ends of pipes are preliminarily matched and cleaned for welding, and then the fittings are fastened at two-three points by manual argon arc welding. Welding of the joint is conducted with a fixed welding head and the pipeline is turned. To prevent fusions inside the pipe, under the welded seam a mandrel from the material not welding with the metal of the pipe is established.

If the pipeline according to some conditions cannot be or is inconvenient to turn during welding, then devices for rotation of the welding head around the fixed pipeline (for example, automatic machine of the type ATV-15-40 of the design NIAT) are used.

Argon arc welding to nonconsumable tungsten electrode is used most frequently. The filler rod is used of the same brand steel from which the pipe is made.

After welding the seams are thoroughly cleaned and subjected to control.

Heading of nipples. The connection of fittings to the pipes is connected with the unnecessary expenditure of the material, great labor input and time. Fittings are usually prepared by grinding from a rod or tubular billets and then are welded to the pipe. Meanwhile in most cases its purpose is to create a small boss of the walls on the end of the pipe, which can be obtained by a simpler method.

Furthermore, the quality of the welded seam and part of metal adjacent to it is lower than the quality of the material of the pipe, especially with tests for vibration strength. At places of welding fusions and a boss are possible, which distorts the shape of the pipe (Fig. 10.6a).

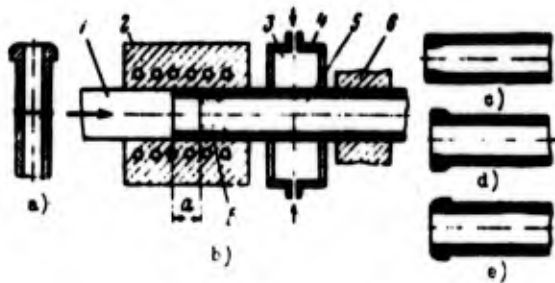

Fig. 10.6. Diagram of the landing of nipples: 1 - punch; 2 - die; 3 - cooler; 4 - pipe connection of the feed of cooling agent; 5 - billets; 6 - rest.

From technological, economic and design points of view, it is expedient to reject welded fittings and make bosses on ends of the pipes by means of plastic deformation. Recently in this direction great experimental works are being conducted, and practical results and technological recommendations are obtained. Figure 10.6b shows a diagram of the heading of nipples.

The billet of the pipe 5 is inserted into the heated die 2 and is secured by rest 6. The end of the pipe in the die is heated to a definite temperature, and the propagation of heat along the pipe is limited by the installation of a cooler 3. Figure 10.6b shows a diagram of the fitting of nipples. Upon the achievement of the temperature of stamping heading of the end of the pipe by punch 1, as is shown by the dashed line and letter B is produced.

The following technological process of the fitting of nipples is recommended:

1. Lubricate the end of the tubular billet on the outside and inside.
2. Produce heading with heating of the end of the billet on the calibrating insert by the reverse method. The form after the heading of the end is shown on Fig. 10.6c.
3. Carry out flaring of the pipe with heating on the internal diameter by the direct method. The form of the end after flaring is shown on Fig. 10.6d.
4. Lubricate the billet on the outside and inside.
5. Calibrate the final form of the nipple with heating.

The form of the end after calibration is shown on Fig. 10.6e. With calibration the formation of a burr is possible, which then departs.

§ 3. Manufacture of Pipelines from Sheet Material

It is impossible to prepare pipelines of large diameters with thin walls in practice from standard rectilinear pipes, since with their bending with small radii folds and breaks of the metal appear. The limitation of dimensions of the engine does not permit making bends of large radii. Therefore, such pipelines are made from sheet metal by means of stamping on the parts with subsequent welding. Sometimes the pipelines have a very complex configuration. Figure 10.7 shows two characteristic subassemblies: a - pipe with a flange and collector for the combustible feed into the combustion chamber of the engine J-2; b - pipeline with a flange for the oxidizer feed established on the injector head of the combustion chamber of the engine AJ 10-138.

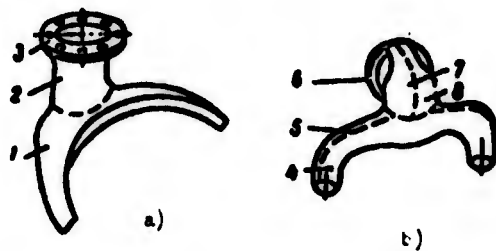

Fig. 10.7. Pipelines of complex form: 1 - shaped collector; 2 - pipe; 3, 6 - flanges; 4, 5 - halves of pipelines; 7, 8 - halves of the pipe.

As can be seen from the figure, it is impossible to prepare these and subassemblies of pipelines similar to them from standard pipes.

The development of the technological process of manufacture of pipelines from sheet material starts from the division of subassemblies into elementary parts, which can be obtained by stamping or rolling.

Thus, subassembly a on Fig. 10.7 can be divided into a shaped collector 1, pipe 2 and flange 3. The form of collector permits preparing it in stamp wholly or from two halves with subsequent welding. The pipe can be prepared from a standard seamless pipe or by means of rolling of the flat billet and connection by a longitudinal welded seam. To ensure the smooth transition, the lower part of the pipe is rolled. Parts obtained in such a way are then welded in a special device.

Subassembly b on Fig. 10.7 can be divided into two halves 4 and 5 of a Π -shaped pipeline, two halves 7 and 8 of a curvilinear pipe (pipe bend) and flange 6. All these elementary parts except the flange can be prepared by stamping from sheet material and then connected by welding.

The giving of the final form to the stamped parts and preparation of the edges for welding is produced by machining. Then the parts are gathered into the subassembly and fastened at several points by electric welding, after which they are finally welded.

Thus, the technological process of the manufacture of pipelines of complex form from a sheet consists of the following operations:

1. Cut of the material.
2. Cutting of flat billets.
3. Stamping of elementary parts.
4. Machining of elementary parts for welding.
5. Assembly and welding of the subassembly.
6. Dressing of the seams.
7. Machining of connecting places of the subassembly.
8. Control and tests.

As can be seen, the technological process is long and sufficiently complex, requiring a large quantity of technological equipment: stamps, devices for the machining of parts, devices for welding and final treatment. These devices are complex, since it is required to maintain dimensions in several planes.

Simplifications of the technological process can be attained by using new progressive methods, namely:

1. Exact casting on patterns to be melted.

2. Electrochemical deposition of the metal on surface of a rod having the form of a finished subassembly with subsequent removal of this rod (by destruction or etching).

3. Plasma spraying of the metal on a rod with its subsequent removal.

4. Winding of the rod with fiberglass with an impregnation by resin and subsequent polymerization.

However, practical application of these methods as yet is not always possible due to the insufficient shaping of conditions of the process, great labor input, low quality of the metal, great expenditures for equipment and other causes.

For example, electrochemical deposition of plasma spraying are as yet provided by metal of the cast type, which in its mechanical qualities considerably yields to sheet metal. But these methods are rapidly being improved and in near future will find wider application.

§ 4. Control, Test and Sealing of Pipelines

With the control of pipelines the geometric dimensions, cross section and quality of welding or brazing are checked.

Geometric dimensions can be measured by universal means or with the help of flat and three-dimensional patterns or mold lofts. The design of one of the mold lofts is depicted on Fig. 10.4. Increased requirements are placed on the accuracy of manufacture of joint places of rigid pipelines. With the installation on the engine these pipelines cannot be bent, and allowed errors at the location their joint places will lead to serious defects of the assembly or even to the impossibility of its realization. This pertains especially to the assembly of pipelines on flanges.

The cross section of pipelines of small diameters is checked by rolling of a ball of assigned diameter. In the control of the section of pipelines of large diameters special gauges or the measurement of external dimensions and thickness of the walls are used.

Control of the quality of welding or brazing is carried out by the same methods and means which were described in § 13 of Chapter 5.

Strength of the pipelines is checked by a hydrotest. At all outlets plugs are established, and inside pressure of the water is created to expose impermissible deformations or destruction of welded seams and other connections. The magnitude of pressure of the hydrotest is considerably higher than the operating pressure and is determined by TU. A certain part of the prepared group of pipelines is subjected to a hydrotest up to destruction and standard tests according to technical conditions (TU).

With the filling of the test pipeline with water it is necessary to see to it that in its bends and other places there does not remain any air. With an increase in pressure of the liquid the remaining air pockets greatly decrease in volume, and with destruction of the pipeline the compressed air is almost instantly expanded, just as in an explosion. This can lead to serious accidents.

A check for airtightness is produced by pneumatic tests with air, air-freon mixture or helium.

To detect places of nonhermeticity with tests by air, the pipeline is put into a water bath. Here one should consider that pipelines of large diameters filled with air possess great buoyancy, and for their submersion into water special devices are required.

These devices must not hinder the inspection of places of nonhermeticity and should allow turning the pipeline for the best inspection. The pressure of pneumatic tests is determined by the TU.

In pneumatic tests of pipelines it is necessary to observe very strictly rules of safety engineering, since a pipeline filled with air or gas under pressure presents great danger of explosion, especially when the internal cavity of the pipeline has great volume and the pressure is high. Only those pipelines the strength of which is checked by hydrotests can be subjected pneumatic tests. The pressure of pneumatic tests should be certainly lower than the pressure of hydrotests. However, even under these conditions unforeseen destructions are possible. Therefore, pneumatic tests conduct in baths having special shielding with observation through armored glass. In the most dangerous cases tests are conducted in armored cabins with remote observation with the help of television installations.

To decrease the volume of air the internal cavity of the pipeline can be filled with plastic balls.

Complex pipelines set in hydraulic ducts are subjected to hydraulic pressure tests by water for the determination of the magnitude of flow friction with subsequent drying. Methods of the hydraulic pressure test and measurements are analogous to those discussed earlier in § 5 of Chapter 8.

The prepared tested and finally accepted rough pipelines are subjected to sealing for the dispatch on assembly of the engine. Sealing is for the purpose of protecting internal cavities of the pipelines from accidental obstruction and protecting places of connections from damage. Specific requirements for sealing are determined by the TU.

CHAPTER 11

MANUFACTURE OF FLEXIBLE PIPELINES

§ 1. Design of Flexible Pipelines

Flexible pipelines are established in those cases when units united by them change their position relative to each other during operation of engine, or when it is necessary to decrease dangerous vibrations of the pipelines.

For example, with control of the thrust vector of the engine by means of rocking of combustion chambers in the main line of the fuel and oxidizer feed to the chamber, it is necessary to establish flexible pipelines, otherwise the chamber cannot deviate from its initial position, but destroying the main lines. With the connection of units by rigid pipelines oscillations and vibration will be transmitted through the pipelines, which can lead to their rapid destruction. The installation of flexible sections in these pipelines protects them from destruction.

The design form and technical requirements for flexible pipelines depend on their assignment and conditions of operation. The most important flexible pipelines operate at high internal pressures and great vibration loads, and therefore requirements of full airtightness and sufficient flexibility are placed on them.

Figure 11.1 shows two types of pipelines: a - with braiding and b - with rings of rigidity. The pipeline with braiding consists of bellows 1 (corrugated thin-walled vessel), braiding 2, two sleeves 3 and two flanges 4. The presence of bellows gives flexibility to the pipeline, and the external braiding supports the bellows from radial deformations, not presenting a bend. The bellows is united with the flange by seam welding or brazing.

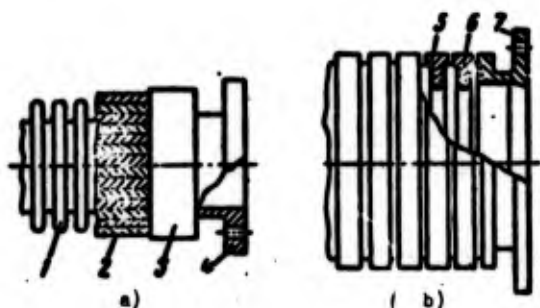

Fig. 11.1. Design of flexible pipelines: a) with braiding; b) with rings of rigidity; 1 - bellows; 2 - braiding; 3 - sleeve; 4 - flange; 5 - bellows; 6 - ring of rigidity; 7 - flange.

Figure 11.1b shows a flexible pipeline with external rings of rigidity, which absorb radial forces from internal pressure. The profile of rings 6 corresponds to the profile of the wave trough of the bellows 5. The bellows is united with flange 7 also by seam welding or brazing. The most important part of flexible pipelines is the bellows. The bellows are made from tubular thin-walled billets or by means of screw spiraling and welding of profile strip.

§ 2. Manufacture of Billets of Bellows

Bellows from important flexible pipelines are prepared from tubular thin-walled billets. The material of the bellows should possess high elastic properties, plasticity and corrosion resistance.

Four methods of obtaining of the billet are used:

1. Deep extraction from the sheet.
2. Combined method.
3. Rolling of the tubular billet.
4. Turning of the pipe from the strip and welding by longitudinal seam.

Deep drawing from a sheet is produced by means of a molded sleeve without thinning of the material and then by gradual hot drawing of the sleeve with thinning of the wall. The quantity of operations is determined by calculation according to methods discussed earlier in § 3 of Chapter 2. For example, Fig. 11.2 shows operation sketches of the obtaining of a billet with a diameter of 32 mm. The material of the billet is stainless steel 1Kh18N9T.

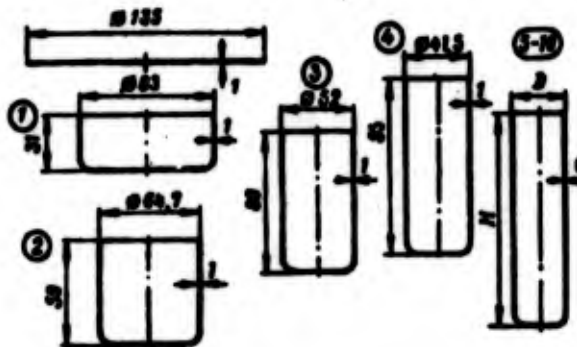

Fig. 11.2. Operation sketches of the drawing of the billet of a bellows.

In the first four operations stamping of the sleeve is produced without thinning of the material from the sheet of the initial billet Φ 135 mm. Then, starting from operation 5, gradual drawing of the sleeve is produced with thinning of the wall and small decrease

in diameter of the sleeve. Drawing is carried out on horizontal broaching machine. The sleeve is put on a punch and stretched through a drawing ring. After operations 7, 9, and 10 cutting of the upper edge at the given magnitude is produced. Numerical values of dimensions of the billet by means of the transitions are given in the following table.

No. of operation	Diameter D mm	Altitude H mm	Magnitude of cutting of mm	Thickness of the wall t mm
5	33.9	118	—	0.92
6	33.6	161	--	0.69
7	33.3	205	11	0.52
8	33	271	—	0.4
9	32.6	340	16	0.31
10	32.3	415	12	0.25
11	32.0	523	—	0.20

Between operations the billets are subjected to annealing for the removal of cold hardening of the metal. After every annealing etching, neutralization, washing, drying and covering of the surface of the billet with varnish are produced. The technological process of the obtaining of billets by the discussed method is long and expensive. The quality of the billets obtained is high.

The combined method consists in the combination of extrusion of the sleeve with subsequent drawing with thinning of the material. From a round flat sheet bar by the method of extrusion one obtains an intermediate cylindrical or conical sleeve, and then by consecutive drawing of it with thinning of the wall it is reduced to the necessary dimensions in diameter of the cylinder and thickness of the wall. The number of operations of extrusion of the sleeve is less than that with the stamping of it without thinning of the wall, and this is the advantage of the method. By means of experience of the firm Lodge and Shipley the most rational form of the sleeve after extrusion is

the frustum of a cone with the diameter of the header equal to the diameter of the next tubular billet of the bellows. Extrusion is conducted on a cone mandrel with thinning of the wall.

A diagram of extrusion of a sleeve is shown on Fig. 11.3a. Subsequently the diameter of the sleeve gradually decreases, and walls will be thinned in operations of extrusion (Fig. 11.3b and c).

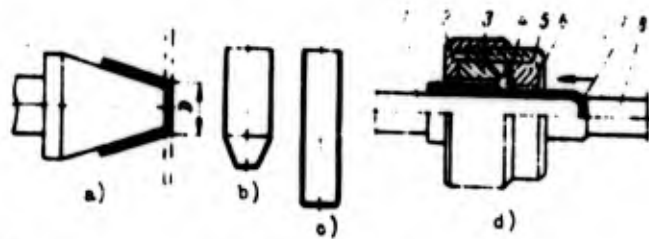

Fig. 11.3. Obtaining of a tubular billet of the bellows: a) extrusion of the cone of sleeve with thinning of the wall; b and c) subsequent drawings; d) rolling by the ball head; 1 - mandrel; 2 - nut; 3, 5 - rings; 4 - ball; 6 - casing; 7 - sleeve; 8 - stop;

Thus just as with the first method, between operations annealing of the billet with subsequent etching, purification and covering with varnish are produced.

Reeling is more a productive method of obtaining seamless tubular billets. As the initial billet for reeling a segment of a standard seamless pipe with a thrust header rolled on one side or stamped sleeve, obtained by drawing without thinning of the material, are taken.

Reeling is produced by a revolving ball head, as is shown on Fig. 11.3d.

The sleeve 7 to be rolled is put on the mandrel 1 and tightened by the stop 8. Reeling is produced by balls 4, found in a wedge-shaped groove, formed by rings 3 and 5. The internal diameter between balls is adjusted to a definite dimension by means of screwing on nut 2 onto casing 6.

The ball head rapidly revolves and slowly moves in the direction of the open side of the sleeve 7 (on the figure from right to left). Here the balls are extruded into the metal of the sleeve and its reeling is produced. The process can be carried out on a hydraulic press or on a spinning lathe. With reeling on a press the ball head does not move, but rapidly revolves from a separate drive, and the mandrel together with the sleeve slowly moves by the motion of the slider of the press. With reeling on the spinning lathe the ball head does not revolve but slowly approaches to the revolving mandrel with the sleeve. With the correctly selected conditions of rolling (number of turns, rate of feed) the billet is sufficiently accurate with a clean surface (V8-V9).

Turning of the tubular billet is produced from a thin strip of necessary width on a special machine having several rows of molding rollers. The shape of the rollers is carried out in such a way that tape gradually with an advance is rolled up into the pipe. Simultaneously with turning dressing of the edges is produced. Then the wound tape enters into the welding apparatus for joint welding of the edges.

Thus, the billet is obtained as a result of a comparatively simple and cheap technological process without multioperation extrusion. A deficiency of this method is the fact that the billet has a longitudinal welded seam. If the quality of the metal of the welded seam or metal near the seam is lower than the quality of the basic metal of the billet, then subsequently with the formation

of corrugations or during the operation with vibration loading the appearance of cracks and destruction of the bellows are possible. It is not always possible to produce butt welding of a very thin sheet with such high requirements for welded seam. The least disturbance of conditions of welding leads to the impairment of properties of the welded seam, which creates a danger of breakdown of the bellows subsequently with its operation on the engine.

For this reason billets with a longitudinal welded seam are used considerably less often than are the seamless, although the latter are considerably more expensive.

§ 3. Forming of Bellows

The formation of corrugations of bellows occurs in two operations. In the first one rolling by a roller of small annular grooves, as is shown on Fig. 11.4a is fulfilled. The billet of the bellows 1 is established on mandrel 3 having annular grooves and is tightened by a revolving clamp 4. The mandrel, together with the billet of the bellows, is rotated, and as a result of the indentation of roller 2 annular grooves will be formed. The pitch of the grooves is calculated proceeding from the unfolded length of the next corrugation. The diameter of the mandrel should be less than the diameter of the billet of the bellows by two depths of the groove plus 0.5-1.5 mm for the possibility of free removal of the procurement from the mandrel.

The second operation is fulfilled in the device depicted on Fig. 11.4b. The billet of the bellows 12 is preliminarily filled with liquid and along the edges is tightened by the grip 9 which interacts with the bushing 7. Then the billet together with the grip is established in the device, as was shown on figure, and through pipe connection 5 inside the billet pressure of the liquid is created. Under the action of this pressure and force of axial compression of the bellows, created slowly by the moving shoe 13, the formation of corrugations in intervals between molding disks 11 occurs. With

axial compression of the billet the molding disks approach, slipping along plungers 10, which is ensured by the uniformity of the corrugation. The profile of molding disks corresponds to the profile of the corrugation. The profile of molding disks corresponds to the profile of the corrugation. Movement of the shoe 13 is carried out by rod 14 of hydraulic drive 16. The pressure of the liquid inside the procurement depends on properties of the material, thickness of the wall and diameter of the billet and is determined by formula

$$p = \frac{\sigma_T s}{D_H} K,$$

where s - thickness of wall in mm; D_H - internal diameter of the billet of the bellows in mm; σ_T - yield point of the material of the procurement in MN/m^2 ; K - coefficient determined by experimental means.

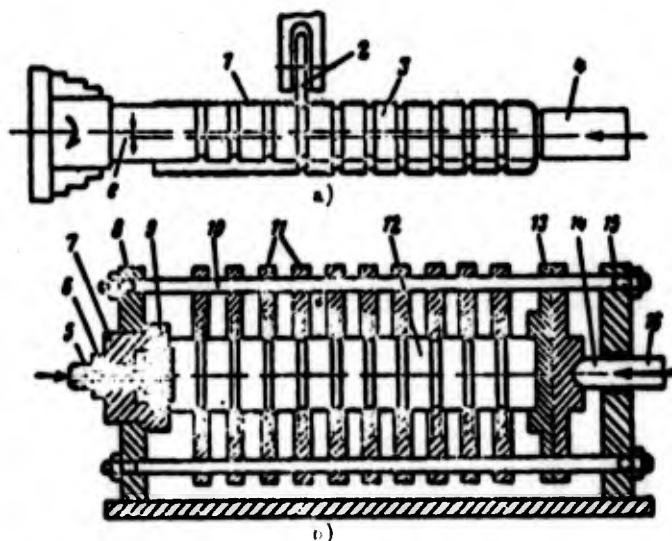

Fig. 11.4. Forming of corrugations of bellows: a) preliminary rolling; b) forming of corrugations; 1 - billet; 2 - roller; 3 - mandrel; 4 - clamp; 5 - pipe connection of liquid feed; 6 - nut; 7 - bushing; 8, 15 - braces; 9 - grip; 10 - plunger; 11 - molding disks; 12 - billet of the bellows; 13 - shoe; 14 - rod; 16 - hydraulic drive.

The hydroforming of bellows can be carried out without preliminary reeling of grooves on the billet in a special machine of the GUS or OU-30 type. The principle of operation of these machines is the same as that of the device depicted on Fig. 11.4.

Besides hydroforming is used also the method of the formation of corrugations by pressing with rubber in an extensible sectional die. A diagram of the stamp for these purposes is depicted on Fig. 11.5. It consists of base 1, die 4, cut into three or four sections, upper plate 3 with punch 5 secured on it and wedges 2. With the lowering of the upper plate sections of the die under the impact of oevels on wedges move to the center, but with movement of plate 3 upwards - sections of the die are opened under the impact of the spring (not shown on the figure). The internal cavity of the die has annular grooves with respect to the form of the corrugations.

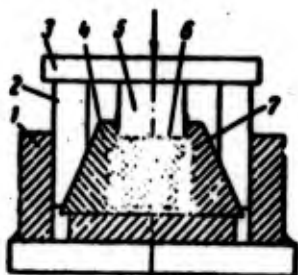

Fig. 11.5. Forming of corrugations by rubber: 1 - base of the stamp; 2 - wedges; 3 - upper plate; 4 - split die; 5 - punch; 6 - rubber; 7 - bellows.

Inside the tubular billet of the bellows a rubber plug is inserted, and then the billet is placed into the die with its opened position. With lowering of the upper plate punch 5 presses on the rubber plug and creates pressure inside the billet. Simultaneously sections of the die shift and its crests of the grooves are pressed into walls of the billet. Thus the formation of bellows occurs.

After the forming plate 3, together with the punch, rises, and sections of the die are opened, and the billet is easily removed from the die.

The force of the press, applied to the upper plate, is defined as the product of the area of the section of the punch on specific pressure of the rubber necessary for forming. The specific pressure of the rubber should be such in order to cause in the wall of the billet a stress approximately equal to the yield point of the material of the billet. Usually the specific pressure of the rubber is taken equal to $20-30 \text{ MN/m}^2$ ($200-300 \text{ kgf/cm}^2$).

The method of the forming of the bellows by rubber is simple and cheap. However, with the forming a considerable extrusion of the material occurs with thinning of wall of 10-15% from the initial thickness of the billet, which is not always permissible.

After operations of forming of the corrugations, the washing, drying, cutting of the faces, tests for airtightness and preparation of edges for connection with the fittings are produced.

§ 4. Connection of Fittings and Assembly

Fittings to bellows are joined by brazing or welding. The form of the fittings is determined by the kind of connection flexible pipeline with elements of main lines of the engine. Sometimes the operation of the connection of fittings is included in the technology of assembly of the flexible pipeline, since certain of its elements can be assembled only prior to the welding of fittings.

The assembly of flexible pipelines of the type shown on Fig. 11.1a is produced in such a sequence:

- 1) on one side of the bellows 1 flange 4 is joined;
- 2) on the bellows brading 2 and two sleeves 3 are put;
- 3) a second flange 4 on the other side is joined to bellows;

4) the braiding is equalized, and on its ends semirings are installed and above them, sleeves 3;

5) pressing of the sleeves for the fastening of ends of braiding is produced.

The assembly of flexible pipelines of the type shown on Fig. 11b is combined with the forming of the bellows, since rings of rigidity 6 cannot be put onto the finished bellows.

Figure 11.6 shows a diagram of welding of a flange to the bellows on an ultrasonic machine for seam welding UZSM-2. Bellows 1 with flange 2 clamped at several points is set into the device welding roller 3 is inside the bellows. Then a pressure between the rollers is created, and the formation of an annular seam by revolving rollers 3 and 8 is produced.

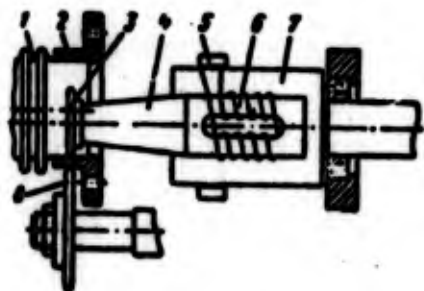

Fig. 11.6. Diagram of the welding of the flange to the bellows: 1 - bellows; 2 - flange; 3 - upper roller; 4 - waveguide; 5 - brushes; 6 - magnetostrictive converter; 7 - cooling; 8 - supporting roller.

The essence of ultrasonic welding consists in the following. From an ultrasonic generator current through brushes 5 is fed to the winding of the revolving magnetostrictive converter 6. Ultrasonic waves obtained in converter are transmitted along waveguide 4 to the welding roller 3. Under the action of ultrasonic oscillations, the metal of parts (bellows and flange) to be welded, pressed between rollers 3 and 8, at the place of their contact passes into a unique quasi-liquid (false-liquid) state and is mixed. After coming out of the zone of welding the metal again passes into a solid state,

forming a continuous metallic connection. Ultrasonic welding occurs at a temperature considerably lower than the melting point. The strength of the welded joint is usually higher than the strength of the base metal, and with tests destruction occurs on the base metal. By ultrasonic welding it is possible to connect different metals which are not connected by usual methods.

P A R T I I I

MANUFACTURE OF BASIC PARTS OF TURBOPUMP UNITS

C H A P T E R 12

TREATMENT OF SHAFTS

§ 1. Design, Material and Selection of the Billet

Shafts of turbopump units (TNA) operate under high loads and great numbers of revolutions. To lighten the weight of them, they are made hollow. The greatest alternating stresses in the metal of a shaft appear on its external surface. In this case sharp transitions, traces from cutting tool and other defects of surface of any form are concentrators of stresses. At these places during the operation cracks can be formed, which will lead to the breakdown of the shaft. Therefore, special attention is given to the cleanness of finish of the surface of the shaft with the introduction in certain cases of strengthening operations. Finishing is performed not only on places under bearings, packing and fittings, but also all other sections of the shaft, not conjugated with other parts.

Great numbers of revolutions (10,000-20,000 r/min and more) force the designer to set very rigid allowances for the coaxiality of necks and fitting places, the accuracy of location of the axial hole, variable wall thickness and other dimensions. The least geometric errors lead to a nonuniform distribution of revolving masses of metal, which induces vibrations and shaking of the turbopump unit.

Figure 12.1 shows the two most characteristic types of shafts: with a flange (a) and without a flange (b).

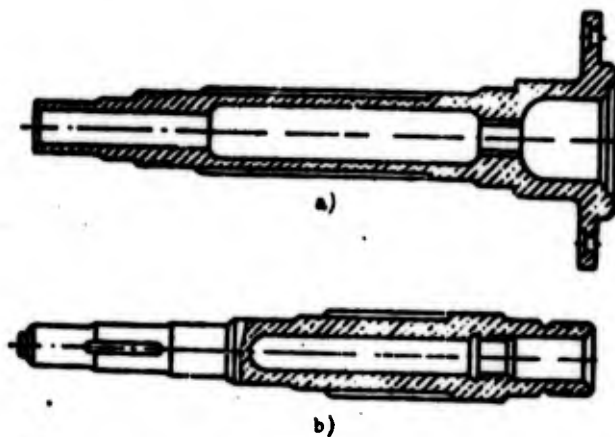

Fig. 12.1. Characteristic types of shafts.

The condition of uniform strength of separate sections of the shaft determines in most cases the step form of axial holes. The most important shafts are prepared from a high-quality allow steel with a tensile strength after appropriate heat treatment of 1000-1200 MN/m² (100-120 kgf/mm²). Steels 2Kh13, 18KhNVA, 40KhNMA, 12KhNZA and certain others are used.

For less important shafts cheaper steels of the type 38KhA or steel 45 are used.

Billets of shafts are obtained by the method of deformation in a hot state - forging, stamping, transverse rolling or rotary pressing. The form of the billet should repeat the form of the shaft as near as possible so that the fibers of the metal are disposed along the configuration of the shaft and with further machining are less than sections of cutting off of the fibers. The parting line plane of the stamp is selected depending upon the form of the shaft. For step shafts without a flange the parting line is made along the axis of the shaft. In the presence of a flange a transverse parting line of the stamp is required. A flange can be formed by heading on a forging machine.

Allowances for machining are set by calculation according to elements or industrial standards compiled on the basis of practice.

The magnitude of the general allowance along the normals is determined depending upon dimensions of the billet and cleanness of the surface of the part.

According to accuracy of fulfillment, the stamped billets are divided into six classes:

1st class - billets subjected to planar sizing of increased accuracy (allowances between calibrated surfaces from 0.15 to 0.30 mm depending upon the dimension);

2nd class - billets subjected to planar sizing of the usual accuracy (allowances from 0.15 to 0.50 mm);

3rd class - billets subjected to hot planar sizing for the purpose of the obtaining on separate sections of more accurate dimensions than is provided by the 4th, 5th, and 6th classes of accuracy;

4th class - billets prepared by usual methods of drop forging with subsequent hot sizing;

5th and 6th classes - billets prepared by the usual methods of drop forging.

Numerical values of allowances for dimensions of billets of the corresponding class are given in reference books.

The billets of shafts of the turbopump unit are usually fulfilled according to the 5th and 6th classes of accuracy.

§ 2. Methods of Treatment

The treatment of shafts is divided into three stages:

1) rough treatment, or roughing;

2) finishing;

3) final treatment and finishing.

With rough treatment the main part of the allowance departs, a hole is drilled and bored, and bases (center deepenings or faces) will be formed for subsequent treatment. The accuracy of the dimensions is usually not higher than the 5th class, and the cleanness of the surface - up to the 3rd class. Treatment is conducted on machines possessing great rigidity under stressed conditions of cutting.

At this stage of treatment of the shaft all defects of the material of billet are revealed, and a segment of the samples and test of them are produced in accordance with technical conditions, so that at subsequent more laborious stages of treatment to allow only billets which correspond in their quality to TU requirements.

At the second stage with finishing a form is given to the shaft similar to the final form with small allowances for finishing operations. Treatment is conducted on exact machines with less stressed conditions of cutting to avoid deformations of the shaft under the action of cutting forces. In necessary cases with treatment of long shafts supports are used.

With final treatment basically operations of grinding, honing, polishing and other finishing operations are used. At the same stage threads, small slits and certain other surfaces are formed, with respect to which there is the danger of damage if they were treated earlier.

The route of treatment of the shaft in many respects depends on the heat treatment and its place in the technological process. In the manufacture of shafts from steels, thermally improved over the whole mass of the metal, the first rough stage of treatment is conducted in a normalized state of the billet for the purpose of easing cutting conditions.

Table 12.1. Standard technological method of treatment of thermally improved shafts (billet: stamping with an allowance for treatment from 3 to 10 mm per diameter depending upon the form and dimension of the shaft).

No. of operation	Operation	Equipment
1	Heat treatment (normalization)	-
2	Cutting of facets centering	Milling-centering machine
3	Machining of external surfaces under a rest (for long shafts)	Turning lathe of increased rigidity
4	Drilling of axial hole)	Turret lathe (for short shafts), horizontal-drilling machine (for long shafts)
5	Boring of axial hole, turning of center faces	Turret lathe (for short shafts)
6	Machining of external surfaces	Lathe-multiblade semiautomatic machine of the 1730 type of hydrocopying machine.
7	Heat treatment (hardening and tempering)	Furnace
8	Segment of sample for test (for shafts of the first group of control)	Turning lathe
9	Restoration of center bases	Milling-centering or turning lathe
10	Grinding of necks under the rest (for long shafts)	Circular grinding machine
11	Boring of hole	Lathe-copying or boring machine
12	Machining of external surfaces	Lathe-multiblade semiautomatic machine of the 1730 type or hydrocopying machine.

Table 12.1. (Cont'd)

No. of operation	Operation	Equipment
13	Milling of grooves, flats and other external surfaces	Keyway milling machine
14	Drilling of radial holes in flanges	Radial drilling machine
15	Grinding of hole	Internal grinding or honed machine
16	Grinding of external surfaces	Circular grinding machine or superfinish.
17	Cutting of slits	Slit-milling machine
18	Cutting of thread	Thread-milling machine
19	Grinding of thread	Thread grinder
20	Polishing of external surfaces	Lathe with head for super-finishing
21	Hardening of working surfaces	Special apparatus for burnishing by rollers
22	Final control	Special indicator instruments and thread gages

Then before finishing heat treatment (hardening, tempering) to the assigned hardness. Such an order of treatment increases the quality (structure of the metal, since the preliminarily treated shaft hardens better and more uniformly. In the manufacture of shafts from viscous steel with separate cemented and hardened sections, the first rough stage of treatment is finished by the grinding of the cemented sections, shielding of the noncemented sections with a copper plating or other method, and by cementation, hardening, tempering and straightening of the shaft.

The recommended standard methods of treatment of shafts [1] are given in Tables 12.1 and 12.2.

Table 12.2. Standard technological method of treatment of cemented shafts (billet see Table 12.1).

No. of operation	Operation	Equipment
1-8	See operations 1-8, Table 12.1	-
9	Grinding of cemented sections of holes	Internal grinding machine
10	Grinding of external cemented surfaces	Circular grinding machine
11	Copper plating of noncemented surfaces	Bath*
12	Cementation, hardening, tempering	Furnace*
13	Dressing and stripping of base faces for hole	Milling-centering or turning lathe
14	Boring of hole	Lathe-copying or boring machine
15	Grinding of necks under rest (for long shafts)	Circular grinding machine
16	Machining of noncemented external surfaces	Lathe-multiblade semiautomatic machine of the 1730 type or hydrocopying machine
17	Cutting of slits	Slit-milling machine
18	Drilling of holes in flanges	Radial-drilling machine
19	Grinding of cemented sections of hole	Internal grinding or honed machine
20-26	See operations 16-22 of Table 12.1	-

*Instead of shielding by copper plating it is possible to provide on noncemented surfaces increased by 1.5-2 mm an allowance which after cementation (prior to hardening) departs by means of machining on machines. This method is recommended in those cases when the application of a protective layer of copper is difficult, for example, on internal surfaces of shafts.

§ 3. Basic Operations of Treatment

The treatment relatively short shafts is conducted on turret lathes with fastening of the billet with a cantilever without support by the rest. The cutting of faces and the drilling and boring of the central hole are fulfilled in one operation. Treatment of step holes starts from the drilling of a hole of large diameter in order to create more rigid fastening of the tool and to decrease its relative length.

Drilling by standard drills is allowed in those cases when the length of the hole does not exceed five its diameters.

With drilling of deeper holes impermissible withdrawal of the drill to the side is observed. Due to this deep holes, which have a length-diameter ratio of more than five, will be formed with special drills, which will be subsequently discussed.

Figure 12.2 shows approximate adjustment of a turret lathe for the surfacing and formation of a central step hole of a shaft.

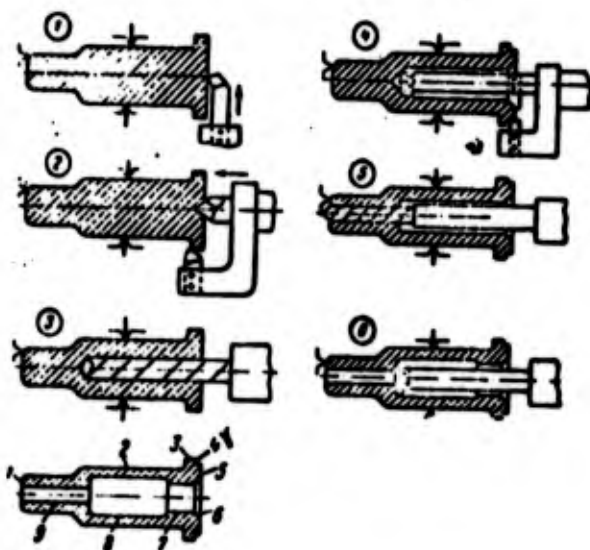

Fig. 12.2. Adjustment of turret lathe for the treatment of a shaft: 1-9 - to be treated surfaces.

The total length of the hole is considerably larger than five diameters of the least hole. But the presence of stages and fulfillment of drilling in a rational sequence permits managing without the application of a tool for deep drilling, since in every transition the length of the drilling does not exceed five diameters of the drill.

The operation is fulfilled in six transitions:

1. Cutting of face 5.
2. Centering and machining of surface 3.
3. Drilling of holes 7 and 8 preliminarily.
4. Boring of hole 7 finally and hole 8 preliminarily, simultaneously obtaining of face 6 and flange 4.
5. Drilling of hole 9.

Deep drilling is a complex and laborious operation. It is carried out by two methods:

1) method of solid drilling (Fig. 12.3a) when the whole metal, subject to removal, is turned into shavings;

2) method of annular drilling (see Fig. 12.3b) when the hole is obtained by means of drilling of the annular passage with formation of a rod in the central part of the hole. In this case less work is expended than in the first method, since only part of the metal subject to removal is transformed into shaving.

The annular method of drilling requires a more complex tool and is used for the formation of holes with a diameter of more than 60-70 mm.

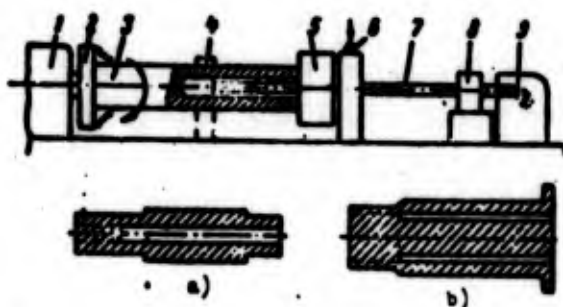

Fig. 12.3. Diagram of deep drilling; 1 - headstock of the machine; 2 - face plate; 3 - shaft to be treated; 4 - rest; 5 - oil receiver; 6 - feed of liquid coolant; 7 - drill; 8 - passing carriage; 9 - shaving receiver.

Deep drilling can be carried out with a fixed drill and revolving article and, conversely, with a revolving drill and fixed article.

However, the second diagram is connected with increased withdrawal of the drill and in the manufacture of shafts of the turbopump unit is almost not used. A diagram of deep drilling is shown on Fig. 12.3. Shaft 3, subject to drilling, is secured in cartridge 2 of the machine and is supported on the other end by a revolving part of the liquid receiver 5. If there is a danger of sag of long shaft, then recess 4 is established. Feed of drill 7 is carried out by carriage 8. A lubricating liquid coolant is fed through pipe connection 6 into oil receiver 5 and further along the annular space between the surface of the drill and walls of the formed hole enters into the zone of cutting. The shaving is washed by a flow of liquid coolant along internal drilling in the shank of the drill and is ejected to shaving receiver 9. Besides the removal of the shaving, the lubricating liquid coolant decreases the force of cutting and decreases losses to friction of the guide part of the drill on walls of the hole. To execute these problems, the liquid used in drilling should possess good cooling and lubricating properties, not causing corrosion of parts of the machine. The following compositions of the lubricating liquid coolant

are recommended:

1) 90% sulphurized oil and 10% kerosen;

2) 7-10% soluble oil (sulphurized), 0.2% calcinated soda, and the remaining water.

It is simpler to carry out feed of the lubricating liquid coolant not through the radial clearance, as was mentioned above, but through the central hole in the shank of the drill with washing out of the shaving through the radial clearance between the drill and walls of the hole formed. However, conditions of the removal of the shaving through the radial clearance is considerably worse. It is necessary to increase the magnitude of the clearance, which decreases the rigidity of the shanks of the drill and lowers permissible conditions of cutting.

The feed of liquid through the central hole in the shaft is used only for large diameters of drills - usually more than 100 mm, when the rigidity of the shaft is sufficient.

With drilling of holes with the diameter up to 100 mm the feed of liquid through the radial clearance is used, in spite of the complication of devices of liquid feed. Figure 12.4 shows a diagram of the design of an oil receiver for the feed of liquid through a radial clearance. The shaft 1 to be machined is supported by flange 3, which has a groove along the form of the face on the end of the shaft. Flange 3 is fastened to bushing 4 and revolves together with the shaft and bushing on radial-thrust bearings 5. Feed of lubricating liquid coolant is carried out through pipe connection 6. To prevent leakage of the liquid, packings 7 and 8 are established.

Deep drilling is carried out by special drills. Figure 12.5a shows one of such drills - a bladed drill for continuous drilling with a diameter of 20 to 85 mm [7]. The feed of the liquid is external, and the removal of the shaving is along the internal channel. Cutting

edges N and T are located at different angles β and β_1 to the axis of the drill. The vertex of the drill b_c is displaced with respect to the axis of drill by magnitude $0.2 d_0$. For division of shaving with respect to its width into small parts, the cutting edge N has steps C. The direction of the drill into the hole during the operation is ensured by keys 1 and 2. A thrust guide key 1 is located opposite the cutting edge N and absorbs the radial force of cutting. The second key 2 is located at an angle of 90° to the cutting edge N for absorbing the tangential component of force of cutting and is called the support guide key. For stripping the unevennesses of the cut a calibrating face f is provided. On the external surface of the drill recesses are cut to ensure the feed of the lubricating liquid coolant to cutting edges of the drill. Bracing of drill to the shaft is produced by shank 3, which has a thread and two centering necks fulfilled according to the 2nd class of accuracy. The thread is made double or triple in order to decrease the pulling of the drill in process of operation and to facilitate screwing with replacement of the drill for its regrinding.

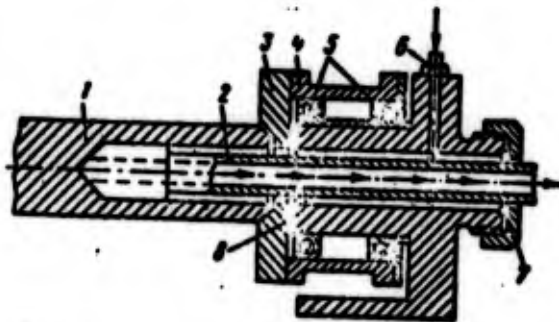

Fig. 12.4. Diagram of design of an oil receiver: 1 - shaft to be machined; 2 - drill for deep drilling; 3 - flange; 4 - bushing; 5 - radial-thrust bearings; 6 - pipe connection for feeding the lubricating liquid coolant; 7, 8 - packings.

Figure 12.5b shows a drill in process of the cutting of metal. Edge N is enveloped by the metal and works under conditions analogous to conditions of operation of a spiral drill, and edge T - under

conditions of operation of a lathe cutter. In virtue of this the rear edge of edge N is sharpened along the spiral (as for a spiral drill) and the rear edge of edge T - along the plane (as for a lathe cutter), Displacement of the vertex of drill b_c from the axis by a magnitude of $0.2 d_0$ creates a constant guaranteed force in the direction of the guide key 1. Due to this the process of cutting passes with the support through key 1 onto the surface of the hole. Therefore, the direction of drilling is determined by the direction of the axis of the hole on a section equal to the length of the guide key 1. With such a nature of the drilling the initial moment of drilling is very important. If the hole in the beginning at depth $(0.6-0.8) d_0$ will have a deviation from the required direction, then subsequently it will no longer be possible to correct this defect, and the hole will be drilled with much withdrawal of drill. To ensure the required direction of the drill, at the beginning of drilling special guide bushings are used in the oil receiver, or before the operation of deep drilling, drilling and boring of the hole of small length $[(0.6-0.8) d_0]$ are produced. The direction of the axis of this hole should coincide exactly with the direction of the next deep hole.

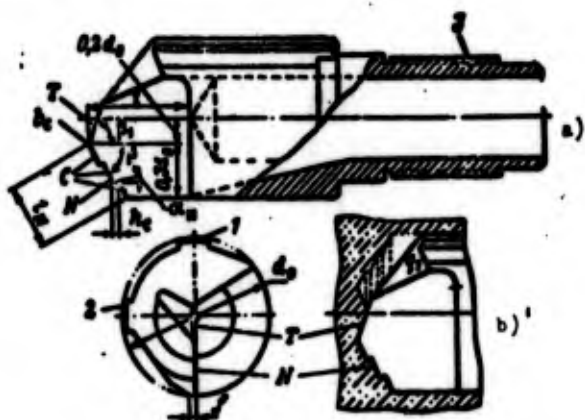

Fig. 12.5. Bladed drill for deep drilling: 1, 2 - keys; 3 - shank.

Maintaining the assigned direction of drilling is also greatly affected by the design and form of the shaft in which the drill is mounted. Distortion of the shaft promotes withdrawal of the drill,

and therefore it is necessary to see to it that distortion is at a minimum. The shaft absorbs the longitudinal force of the feed and twisting moment from forces of cutting.

In the presence of initial distortion of the axis of the shaft, under the action of the axial force buckling appears, which considerably increases the initial distortion. The increase in distortion is also affected by the nonuniform rigidity of the shaft due to the variable wall thickness. In order to avoid great distortions affecting the withdrawal of the drill, the shaft should be rectilinear and possess high uniform rigidity.

Besides bladed drills, drills more complex in manufacture of the KKZ type, which have another form of sharpening of the cutting edge are also used. The magnitude of the feed with drilling by KKZ drills can be approximately twice greater than that with drilling by a bladed drill; the productivity of the process of drilling is increased accordingly.

A further increase in the productivity of drilling of deep holes is attained by the application of special drills equipped with plates of hard alloys and having design adapted for high-speed drilling.

With high-speed drilling according to the first scheme, when the part revolves and the drill does not revolve but has only movement of the feed, to ensure the necessary speed of cutting the part should revolve with a high number of revolutions. If in this case the external surface of the shaft is not treated, then undesirable vibrations due to the instability of masses of the shaft appear. Therefore, the operations of high-speed deep drilling should precede the machining of external surfaces of the shaft and cutting of its faces. This requirement is in contradiction with recommendation given in standard technological processes. However, with deep drilling by a tool of contemporary design, and with good servicing of drill, alignment of the shaft and observance of the correct procedure of drilling, withdrawal of the drill from the assigned axis is a total of 0.1-0.3 mm per linear meter. The obtained small variable

wall thickness can be fully corrected subsequently with complete finishing of the shaft. With high-speed deep drilling the speed of cutting is 6-10 times higher than in drilling with a bladed drill. For example, in the drilling of holes with a diameter of 50-85 mm by drills equipped with plates of hard allow T15K6, the following conditions of cutting are recommended [7]: for steels with a temporary tensile strength of 600-700 MN/m² (60-70 kgf/mm²), the speed of cutting is 190-165 m/min and feed 0.12-0.17 mm/rev; for steels with a temporary tensile strength of 800-900 MN/m² (80-90 kgf/mm²) the speed of cutting is 155-135 m/min and feed 0.09-0.15 mm/rev.

To create so high cutting speeds a high number of revolutions of the shaft are required, which is not always possible according to conditions of operation of the machine. Therefore, sometimes drilling with simultaneous rotation of both the part and the drill is used. Rotation of the drill in this case is carried out by a separate drive.

Boring of Holes

With deep drilling a certain distortion of the axis of the hole due to withdrawal of the drill is obtained. Furthermore, with heat treatment the billets are deformed, and the axis of the shaft is distorted. The dressing of shafts after heat treatment removes great distortions, but after dressing there still remains certain distortion. Therefore, to obtain the assigned rectilinearity after drilling and heat treatment, the holes are bored. In process of boring the necessary ledges, grooves and smooth transitions from one diameter to the other can be obtained.

The boring of holes of one diameter over the entire length of the shaft is fulfilled with boring heads with guide plates. The boring of step holes is fulfilled by a cutter secured on a mandrel, as is shown on Fig. 126a.

Transition from the treatment of one diameter to the other and also the formation of smooth couplings, faces and other forms are

produced automatically with the help of a hydraulic or electrical tracking device. Figure 12.6a shows a diagram of boring step of a hole on a master form. The boring cutter 1 is set in the mandrel 3, which is secured on a three-jawed cartridge of the machine and is supported by the recess 2.

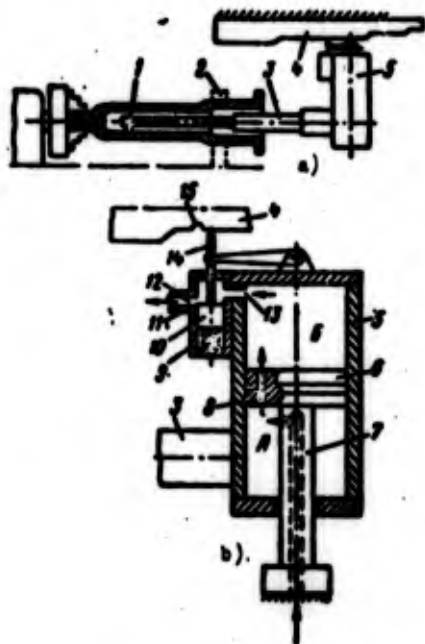

Fig. 12.6. Boring of step holes: 1 - cutter; 2 - recess; 3 - mandrel; 4 - master form; 5 - hydro-support; 6 - piston; 7 - rod; 8 - hole in piston; 9 - housing of valve device; 10 - valve; 11 - oil tap; 12 - valve window; 13 - hole; 14 - thickness gage; 15 - step.

A diagram of the operation of the hydraulic tracking system is depicted on Fig. 12.6b.

The working fluid (oil) is fed through the drilling in rod 7 (shown by a dashed line) and enters into cavity A of the hydrocylinder. Rod 7 is fastened stationarily to support guides of the machine. Through hole 8 in piston 6 the oil will overflow in cavity 5 of the hydrocylinder and further through hole 13 enters into the valve device 9 and through the valve window 12 flows out into the overflow pipe 11. At a certain position of the edge, valve 10 with respect to the valve window 12 advances the equilibrium of the system, and the hydrosupport 5 will be stationary with respect to the piston 6

and rod 7. At such position there occurs longitudinal feed of the hydrosupport together with mandrel 3 secured on it and boring of hole of definite diameter. Together with the hydrosupport the thickness gage 14 moves, slipping along the working edge of the master form 4. This advancing equilibrium will be maintained until the thickness gage 14, slipping over the master form, encounters the step on the master form. In the presence of a step on the master form the thickness gage will move valve 10, the valve window will be closed or opened, which will disturb the equilibrium of the system, and the hydrocylinder will be driven.

Let us examine what will occur with the encounter of the thickness gage 14 with step 15 on master form 4 (see Fig. 12.6b). The thickness gage will move in a direction toward the master form, and in that same direction valve 10 will move, covering the window 12. This will lead to a cessation of oil overflow and, consequently, to an increase in oil pressure in cavity 5. The pressure in cavities 5 and A is equalized. But the effective area of the piston 6 on the side of cavity 5 is larger than on the side of cavity A (due to the exclusion of the area of the section of the rod 7). Consequently, the force of the pressure on the piston on the side of cavity 5 will be larger, and the hydrosupport 5 together with mandrel 3 will start to move in a direction toward the master form, i.e., in the same direction in which the thickness gage 14 moves. But movement of the hydrocylinder 5 will cause also a movement of housing 9 of the valve device fastened with it and opening of the window 12. Movement of the hydrosupport 5 and mandrel 3 will continue until the thickness gage 14 and valve 10 are stopped. After that the equilibrium of the system again advances. Consequently, the system constantly tracks the position of the thickness gage and valve, and this is why it is called a hydraulic tracking system.

With movement of the thickness gage and valve in a reverse direction - from the master form as a result of the encountered step on the working edge of the master form there will occur an increase in cross section of the valve window 12, in consequence of which the

pressure in cavity B will drop. Since the section of hole 8 in piston 6 is small, considerably less than the section of the valve window, then the pressure in cavity A will remain practically constant. In virtue of the difference in pressures in cavities A and B, the hydrocylinder will start to move to the side of the master form, i.e., will also track the position of the thickness gage and valve.

With boring the force of cutting somewhat bends the mandrel and releases cutter, which can be considered in adjustment of the machine. The small constant squeezing of the cutter does not affect the accuracy of the treatment, since the error will be identical over the whole length, and it can be removed by adjustment of the machine. If, however, squeezing will change, this will lead to distortion of the form of the hole. The magnitude of squeezing of the cutter is determined by equation

$$f = \frac{Pl^3}{3EI},$$

where P - force of cutting; l - distance from the edge of the cutter to the place of fastening of the mandrel (length of the cantilever); E - elastic modulus of the material of the mandrel; I - moment of inertia of the cross section of the mandrel.

From this formula it is clear that the squeezing of the cutter depends on the force of cutting and overhang of the cutter (length of the cantilever). The overhang especially has a great effect (in the third degree). If with a recess in the hole the overhang will change, for example, by an advancement of the mandrel, then the squeezing of the cutter will increase and the hole will be a cone. Therefore, it is better to conduct boring without a change in the overhang of the cutter, and this especially pertains to finish boring of exact holes. With rough boring the force of cutting changes due to the irregularity of the allowance along the length of hole, which will also cause an irregularity in squeezing of the cutter and distortion of the form of the hole. Therefore, boring of exact holes should be conducted at first preliminarily, leaving a small uniform allowance over all steps, and then finally up to the assigned dimensions.

Machining of External Surfaces

Rough and finish machining of external surfaces is fulfilled on lathe multiblade semiautomatic machines of the type 1730, 116-2, 1B16-2 or on hydrocopying machines. Rough machining is conducted under stressed conditions of cutting and requires more rigid machines with powerful drive.

Usually multicut lathes and semiautomatic machines have two supports - front and rear.

The front support has longitudinal and transverse motion and is used for longitudinal machining.

The rear support has only transverse motion and is used for the cutting of faces, formation faces, grooves, and shaped grinding by profile cutters.

Secured to every support are a few cutters (10 and more) for the treatment of several surfaces simultaneously. By this the concentration of operations and reduction of time for treatment are attained.

Movement of the supports is automated: having completed the treatment, they automatically return to the initial position, and the machine also stops automatically.

There are two methods of the adjustment of cutters for machining.

The method of consecutive machining (Fig. 12.7a). This is when every cutter is set at a definite diameter and steps of the shaft are machined consecutively one after another according to movement of the support in the direction of longitudinal feed. At the beginning of treatment cutters 1, 2 and 3 occupy the position shown by the solid line. After cutter 1 passes path l_1 , cutter 2 will operate, etc. At the end of the treatment the cutters will occupy the position shown by the dashed line. Adjustment is fulfilled in such a manner so that all cutters finish the operation simultaneously.

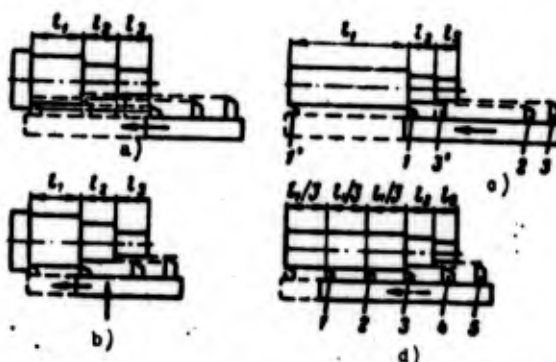

Fig. 12.7. Methods of machining of a shaft.

The machine time of the treatment is determined by the magnitude of the path of the first cutter, i.e.,

$$T_m = \frac{l_1 + l_2 + l_3}{ns} \text{ min,}$$

where s - feed in mm/rev; n - number of revolutions of the shaft machined per minute.

The method of longitudinal machining with preliminary incision (Fig. 12.7b). At the beginning of treatment cutters 1, 2, and 3 occupy the position shown on the diagram.

With a transverse feed of the cutters they will cut into the billet at an assigned depth and then machining by every cutter is produced on the corresponding section. With this method the machine time for treatment is considerably reduced, since the path passable by the support in the direction of the longitudinal feed is equal to the length of the long step and not the sum of lengths of all the steps, as in the first method. Second method can be used when by the second and third cutters it is possible to remove the whole allowance for one passage.

If the length of steps of the shaft to be machined greatly differ, as is shown on Fig. 12.7c, then it is expedient to divide the long step into several sections and produce machining with preliminary incision, as was shown on Fig. 12.7d.

Both the first and second method of machining, besides cutters of longitudinal grinding, on the rear support cutters for transverse grinding of grooves, faces and other surfaces are installed.

The quantity of simultaneously working cutters is limited by the rigidity shaft to be machined and power of the drive of the machine. Shafts of low rigidity cannot be machined simultaneously by several cutters.

Recently for the machining of step shafts, machines with hydro-duplicators or other tracking systems have been widely used. The principle of operation of the hydroduplicator has already been examined by us in reference to the boring of holes (see Fig. 12.6).

In the machining of external surfaces, instead of a mandrel with the boring cutter on a hydrosupport a cutter holder is secured. Machining is conducted, as a rule, by one cutter. As compared to multiblade machining, expenditures of machine time during the operation on a hydrocopying machine are considerably more. However, it is impossible to say this with respect to piece-calculation time, which determines the economy of the treatment. This is explained by the fact that the adjustment of a large quantity of simultaneously working cutters occupies much time. Furthermore, the wear of cutters is unequal, and the squeezing of the cutters changes, which is reflected on the accuracy of the treatment. The adjustment of a multicut lathe is complex. In machines with a hydrotranscriber one cutter operates and the adjustment is comparatively simple. The time for adjustment and subadjustment of hydrocopying semiautomatic machines occupies approximately 20-40 min, which is two-three times less than that for adjustment of multicut lathes.

The maintenance of hydrocopying semiautomatic machines is considerably simpler and requires less time than that in the servicing of multiblade semiautomatic machines. Furthermore, the machining on hydrocopying semiautomatic machines can be conducted with higher speeds of cutting than can multiblade treatment. This means that

piece-calculation time with treatment on hydrocopying semiautomatic machines in many cases is less than that with treatment on a lathe multiblade semiautomatic machines. The cost of the treatment is also in many cases less.

However, it is impossible to say that the application of multiblade semiautomatic machines in all cases is economically unprofitable. In every concrete case one should produce a comparative economic analysis. For the hydrocopying machining of step shafts lathe hydrocopying semiautomatic machines of models 1712, 1722K, MR-27, MR-29 and 1732 are used. It is possible also to conduct hydrocopying machining on screw-cutting lathes of the 1K62 type which is equipped with a hydrosupport.

With machining on single-mandrel multiblade semiautomatic machines usually the following classes of accuracy of treatment with respect to diameter are attained: with rough machining - 5th, with clean - 4th, in length 5th. With very thorough adjustment the 3rd class of accuracy can be obtained. With machining on hydrocopying machines there is obtained, as a rule, a higher accuracy and the best cleanness of surface.

§ 4. Finishing Operations

In finishing operations the accuracy of dimensions of the shaft assigned by drawing and cleanness of its surfaces are attained. The following forms of finishing are used: grinding, fine (diamond) turning, finishing by abrasive bars, lapping, rolled by rollers. The selection of a certain form of finishing is determined depending upon technical requirements for the finished part and the presence of equipment in workshops of the plant.

Grinding is the most widespread basic form of finishing of external and internal surfaces. The following forms of grinding are used:

a) preliminary;

b) finishing;

c) fine.

The first two forms of grinding are used the most frequent. In the case of an accuracy of dimensions of the 2nd class and cleanness of surface of the 7-9th classes are attained.

Fine grinding is used when it is required to obtain an accuracy of dimensions with respect to the first class and cleanness of the surface of 10-11th classes.

External surfaces of shafts are ground on circular grinding machines with installation in centers or in a chuck with a support of the second end by the center. The peripheral velocity of the grinding wheel is 30-50 m/s, and the peripheral velocity of the shaft to be ground is from 0 to 50 m/min.

Short sections of shafts, just as hollows, grooves and ledges are ground by circles of appropriate width and profile with transverse feed by the method of incision. The grinding of longer sections is fulfilled by the second method with longitudinal feed of the shaft. The revolving shaft to be ground accomplishes together with the table of the machine longitudinal motions alternately in both directions. The magnitude of longitudinal feed depends on the thickness of the circle (dimension of the circle along its axis of rotation). With preliminary grinding longitudinal feed is usually 0.4-0.7 of the thickness of the circle in one revolution of the part to be ground and with finishing grinding, 0.2-0.3 of the thickness of the circle. After every longitudinal movement transverse feed of the grinding wheel (incision) at 0.005-0.02 mm is produced. This method of grinding is the most widespread.

Fine grinding is conducted the same methods as those of finishing but with increased speeds of cutting (the peripheral velocity is more than 40 m/s), at low speeds of rotation of the part (peripheral velocity up to 10 m/min), small depth of cutting (less than 0.005 mm) and intensive cooling. The grinding wheels used are soft fine-grained. The grinding of holes is fulfilled on internal grinding machines.

Fine (diamond) grinding. The essence of this method of finishing consists in the cutting of a thin layer of metal at high speeds and low feeds by the cutter equipped with a diamond or hard alloy. It is used, mainly, for the finishing of viscous metals, with the grinding of which rapid grease clogging of the grinding wheel occurs. However, it can be successfully used for the finishing of steel heat-treated shafts. With diamond grinding (or boring) it is easy to attain an accuracy of the 2nd and even 1st classes and cleanness of surface of the 9th and 10th classes. Diamond boring is especially effective in the finishing of small holes, the grinding of which is very difficult and associated with great wear of grinding wheels.

Finishing by abrasive bars - superfinish. There are two methods of the finishing of surfaces by abrasive bars: superfinish and homing process.

A diagram of superfinish finishing of the external surface of the shaft is depicted on Fig. 12.8. The shaft is rotated and the superfinish head moves along the axis of the shaft, accomplishing oscillatory motions with good cooling (kerosene with oil is used). The number of oscillations is from 200 to 1000 per minute with the range of oscillations of 2-6 mm. The specific pressure on the bars very small - a total of $0.01-0.2 \text{ MN/m}^2$ - in consequence of which occurs cut very thin layer of metal and smoothing of advancing combs and notches remaining from the preceding treatment. By a superfinish a cleanness of the surface of the 14th class can be obtained.

Lapping is the final finishing of ground surfaces up to a high cleanness (up to the 12-14th classes). The accuracy of dimensions

obtainable by lapping is up to the 1st class inclusively. Lapping is carried out by special laps encircling the surface to be treated. On the surface of the lap, which touches the part to be treated, there is applied a paste, which consists of very small abrasive powder (magnitude of the grain from 3 to 20 μm) and chemically active substances or an abrasive powder with oil. The surface of the lap should hold abrasive grains well. For this purpose the laps are prepared from a gray fine-grained perlitic cast iron, which holds abrasive grains at places of graphite inclusions, or from soft metals or alloys - copper, bronze and lead.

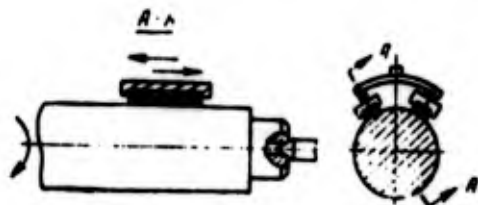

Fig. 12.8. Superfinish of a shaft.

The material of the lap should be softer than the material to be treated. The abrasive grains cut into soft metal and are held there in the process of the operation. For the best holding of grains of the abrasive, the laps are usually charged, i.e., into their working surface grains of the abrasive are forcedly introduced. The pastes used with chemically active substances oxidize the surface to be treated and form an oxide film, which easily departs by abrasive grains entering into the composition of the paste.

If the lapping with finishing of the shafts occupies much time, then it is expedient to conduct it on special equipment.

In the simplest case for the finishing of separate sections of the shafts (for example, places under collar packings), lapping is conducted on lathe or other standard machines with the application of a simple device.

Lapping achieves mainly an increase in cleanness of the surface. It cannot smooth the conicity or oval shape of the holes.

Rolling by rollers. Rolling of the external surface is carried out by one or several hardened steel rollers under pressure.

A diagram of rolling is shown in Fig. 12.9, where a - rolling of cylindrical sections and b - rolling of fillets.

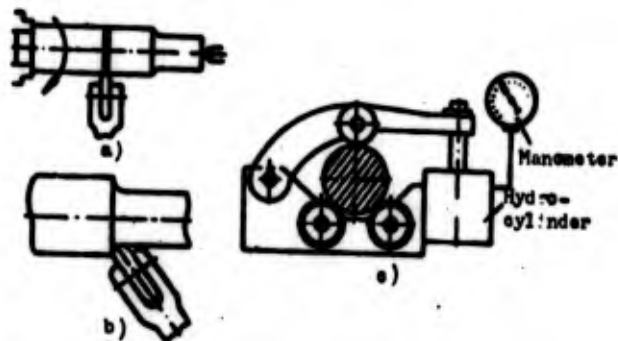

Fig. 12.9. Diagram of rolling with rollers.

As a result of rolling under pressure microroughnesses of the surface are smoothed, and a workhardened layer, which increases the fatigue strength of the part is created. Rolling can be fulfilled on a lathe or turret lathe. The part is set in the chuck or on the centers and the device with the rollers - on the support. Figure 12.9c shows a diagram of the device for rolling. The pressure of rolling is created by a hydrocylinder. To control the magnitude of pressure, a manometer is established.

Rolling of the surface is accompanied by a decrease in dimension of the part due to smoothing of roughness of the surface and plastic deformations.

CHAPTER 13

TREATMENT OF DISKS OF TURBINES

§ 1. Construction, Material, and Selection of Billets

Disks of turbines of the turbopump unit operate at a large number of revolutions, in consequence of which in the metal high stresses from the action of centrifugal forces appear. Furthermore, thermal stresses from the irregularity of heating of the metal of the disk appear.

Disks of turbines are prepared from high-alloy steels and alloys possessing high strength and heat resistance. Steels EI415, EI481, EI395, Kh18N9T and alloys EI437B, EI617 (KhN70VMTYu) and others are used.

The form of the disks is determined from the condition of uniform strength, i.e., approximately equal to the loading of the metal in all sections of the disk.

Figure 13.1 shows several characteristic designs of disks of turbines. The disk consists of a boss for connection with the shaft, a rim for the fastening of blades and a central part, which connects the boss with the rim. The load from centrifugal forces increases with the approach toward the boss, and the diameter of the section decreases, which causes the necessity to fulfill the central part with gradual thickening toward the boss. Profiles A and B of the

central part are complex, which hampers treatment of the disk. Although face surfaces A and B are not joined with the other parts, they must be carried out exactly with high cleanness of the surface. All defects of machining in the form of scratches (traces from the cutter) or sharp transitions are concentrators of stresses and lower the mechanical strength of the disk. The equal distribution of mass of metal along the disk is of very great importance.

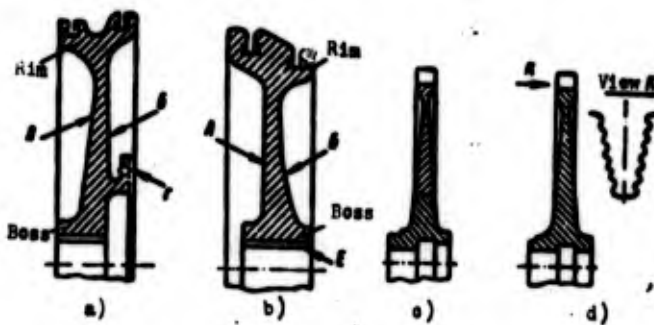

Fig. 13.1. Design of disks of turbines of the turbopump unit.

Even small one-sided bosses lead to the irregularity of distribution of the mass, which leads to instability. With rapid rotation of unbalanced disks, impermissible vibrations of the turbine, capable of leading to an accident appear. Therefore, in designing of disks rigid tolerances on all dimensions of the disks are assigned.

Especially high requirements with respect to the accuracy of treatment are placed on mating dimensions - fitting hole in the boss or seating bosses and grooves for the fastening of blades. Seating bosses and holes in the boss are usually made with respect to the 2nd class of accuracy. Tolerances on dimensions of the groove for fastening of blades is 0.01-0.03 mm. The allowed play of external surfaces of fitting places is 0.03-0.06 mm.

Transmission of the torsional moment from the disk to the shaft is carried out by bolts or pins inserted into holes Γ (see Fig. 13.1a) or slits E (see Fig. 13.1b). Sometimes the shaft is turned simultaneously with the flange, and the turbine disk is welded to the flange of the shaft, as is shown on Fig. 13.1c. With such design of the disk the saving of expensive heat-resistant alloys is attained, since the shaft is prepared from cheaper steels.

In designing of disks of turbines very much attention is given to the rational method of fastening of blades, taking into account design strength and manufacturability of the structure

The greatest design strength with minimum weight of the disk is attained when the blades are made as one whole with the disk. For such disks the rim is the lightest. However, the technology of their manufacture complex and associated with great expenditure of labor. Furthermore, the quality of treatment of the profile of the blades is higher if the blades are prepared separately from the rotor. Poor finishing of the blades lowers the efficiency of the turbine. All these factors are analyzed in detail, and in every concrete design of the turbopump unit the most rational solution is found.

Billets for disks are obtained by stamping or casting. Large diameters of disks with a relatively thin crosspiece between the rim and boss do not permit obtaining stamped billets with small allowances for machining. At certain places the allowances reach 8-10 mm to the side. The calculation of allowances is produced according to the same method as that for shafts.

Stamped billets are supplied in an annealed or normalized state.

On the surface of the billets there should not be any cracks, laps, double skins, foreign inclusions and other defects disturbing the continuity of the material. A certain part of the billets from every melt is cut, and the internal structure of the metal is

investigated. Shrinkage porosities, bubbles, stratifications, cracks and nonmetallic inclusions visible by the naked eye are not allowed.

All remaining billets are subjected to a check for continuity of the material by ultrasonic or other method of control. For every group of billets there should be a corresponding documentation represented by plant (or workshop) - supplier.

Billets of disks of turbines made as one whole with blades are obtained by casting from wax patterns.

In spite of the apparent benefits of the obtaining of billets of disks of turbines as one whole with the blades, in real conditions sometimes it is more expedient to make the blades separately with subsequent connection of them with the disk with the help of locks or by welding.

§ 2. Methods of Treatment

The machining of disks of turbines is conducted in four stages:

1. Roughing and control of quality of the billets.
2. Preliminary treatment.
3. Finishing.
4. Final finishing.

In the first stage from the faces a surface layer of the metal is taken and both the surface and internal defects of the billet. Internal defects are revealed most frequently by the ultrasonic method.

Subsequent treatment is given only to the billets recognized as being suitable and satisfying technical conditions.

In the second stage preliminary treatment of external and face surfaces is produced and the billet is given a form similar to the form of the disk. Allowances for subsequent operations remain the minimum necessary taking into account corrections of warpings with heat treatment, which is conducted after the second stage of machining. The magnitude of warping is determined by experimental means. At large diameters of the disks warping in the plane of the faces attains 0.8-1 mm.

In order to smooth these warpings, it is necessary to take in subsequent operations from every end a layer of metal with a thickness of 1.5-3 mm.

The third finishing stage of machining starts from the preparation of adjusting technological bases. Taken as bases in finishing and final finishing stages of machining are such surfaces which determines the position of the disk in the subassembly during its operation in the turbine. Usually this is the central hole or seating boss. With respect to this seating hole or boss all the allowed misalignments of surfaces of the disk (allowed plays) are assigned, which is recorded in technical conditions on the drawing of the disk.

In the last finishing stage of treatment of the disk, the polishing of nonworking surfaces, the drilling of small holes, static balancing, anticorrosive treatment and certain other operations are fulfilled.

The method of treatment is developed in every concrete case, taking into account the assigned design of the disk in reference to the available equipment and by following the experience of production.

As a first approximation the following standard technological method is recommended [1].

Table 13.1. Standard technological method of treatment of the disk.

Operation	Equipment
Billet - stamping in closed stamps: allowance for treatment, 6-12 mm (supplied in an annealed or normalized state)	
Preliminary roughing of faces (bases - external diameter and protruding)	Lathe or vertical turret lathe
Ultrasonic control (for turbine disks)	Special apparatus
Preliminary treatment of external surface and faces	Vertical turret or automatic lathe
Heat treatment	Furnace
Treatment of base surfaces faces, seating bosses, top, central hole or hole in bosses	Vertical turret or automatic lathe
Treatment of shaped part of the face	Lathe-copying machine
Milling of fillets or grooves	Vertical milling machine
Restoration of bases	Vertical turret or automatic lathe
Final treatment of faces, top and precision fitting surfaces	Lathe-copying or special automatic lathe for bilateral treatment
Polishing of nonworking surfaces (with flexible polishing wheel)	Automatic lathe
Milling of grooves (for disks of turbines)	Horizontal milling or gear-milling machine
Broaching of grooves	Horizontal drawing or vertical drawing machine
Drilling of holes	Vertical-boring or radial-drilling machine
Cutting of face slits	Horizontal milling machine or slitdrawing semiautomatic machine

Table 13.1. (Cont'd)

Operation	Equipment
Metal-working treatment	Bench
Static balancing	Special apparatus
Final control	Special instruments
Anticorrosive treatment (anodizing or oxidizing)	Bath

Note. For disks or turbines of type a and b (see Fig. 13.1), operations of milling and broaching of grooves are replaced the grinding of annular T-shaped grooves.

§ 3. Fulfillment of Basic Operations

In the treatment of disks a large part of the works is fulfilled on vertical turret, turning turret and hydrocopying lathes. Preliminary treatment is conducted under as stressed conditions of cutting as possible simultaneously by several cutting tools, which reduces the time on treatment but creates great loads on the machine and tool.

Forces of cutting, which act with the machining of the rim and parts adjoining to it, are applied on the large arm and generate a great torsional moment. In order to keep the disk from turning over, it is required to use powerful clamps or provide special devices for absorbing the torsional moment. Let us explain this on the diagram shown in Fig. 13.2. Let us assume that the vertical force of cutting P_z acts on the radius R , and fastening of the part is produced after the flange with diameter $2r$.

To keep a part from turning over, the total moment of forces F of friction between the part and the pressing cams should be equal to the moment of force of cutting P_z .

$$KnFr = P_c R, \quad (I)$$

where n - number of pressing cams; K - safety factor of fastening (taken from 1.5 to 2).

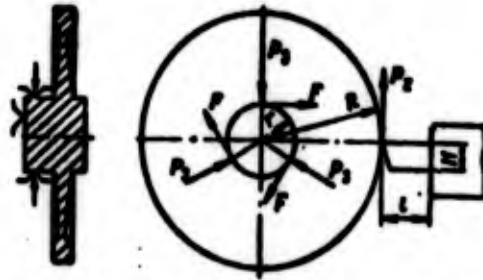

Fig. 13.2. Determination of the force of a clamp with the treatment of disks.

The frictional force is connected with force P_c of the clamp by the following equation:

$$F = P_c f, \quad (II)$$

where f - coefficient of friction between the part and cams (taken from 0.15 to 0.3, depending upon the state of the surfaces).

Substituting the value of force F into equation (I) and converting, we will obtain the formula for the determination of the force on each cam:

$$P_c = \frac{P_c R}{Knfr}.$$

Example. Determine the force of a clamp for retention of the turbine disk with machining on a diameter of 600 mm. Fastening after the bushing $d = 100$ mm.

The forcing of cutting $P_z = 5.8 \text{ kN}$ (580 kgf).

$$P_s = \frac{5.8 \cdot 1000}{2.3 \cdot 0.25 \cdot 100} = 23.2 \text{ kN} (2320 \text{ kgf}).$$

Consequently, each cam should develop a force of pressure on the part of more than two tons.

In order to decrease strengthening of the clamp, sometimes in the disks special technological holes for the fastening of guide devices are made.

In the operation with stressed conditions of cutting calculations of strength and magnitudes of flexure of the cutting tool and holders are also produced.

Force P_z , which is allowable with respect to strength of the holder, is determined by the following formulas:

for holders of rectangular cross section

$$P_s = \frac{BH^2[\sigma]_n}{6l};$$

for holders of round cross section

$$P_s = \frac{\pi d^3[\sigma]_n}{32l}.$$

In these formulas: B - width of the holder; l - overhang (see Fig. 13.2); H - height of the holder; d - diameter of the round holder; $[\sigma]_n$ - allowed bending stress of the material of the holder.

In working with cutters equipped with plates of hard alloys, a comparison of forces of cutting with allowed forces on plates is conducted.

If forces of cutting are greater than those allowed, then the section of the shaving decreases.

Furthermore, loads on the machine are checked, and they are compared with those allowed.

The effective power of cutting with operation simultaneously by several cutters if calculated according to formula

$$N_e = \frac{P_{z1}v_1}{60} + \frac{P_{z2}v_2}{60} + \frac{P_{z3}v_3}{60} + \dots \text{ (kW)},$$

where P_{z1} , P_{z2} , P_{z3} , ... - vertical forces of cutting of cutters 1, 2, 3, ... in kN; v_1 , v_2 , v_3 , ... - speed of cutting of cutters 1, 2, 3, ... in m/min.

The total torsional moment of cutting acting in cutting by several cutters simultaneously is determined by formula

$$M_k = P_{z1}R_1 + P_{z2}R_2 + P_{z3}R_3 + \dots$$

where R_1 , R_2 , R_3 , ... - radii on which cutting by cutters 1, 2, 3, ... occurs.

The obtained effective power and total torsional moment of cutting are compared with those allowed by the machine on which treatment is produced. Methods of determination of the maximum allowed torsional moment and effective power of cutting, taking into account losses in the mechanism of machine, are discussed in the course "Metal-Cutting Machines" and are not given here.

With finishing the basic attention is given to achievement of the assigned accuracy and cleanness of the surface. Important in this stage is the correct selection of adjusting bases and methods of fastening of the disk.

In first finishing operations a central fitting hole or seating bosses are bored. In subsequent operations these fitting holes and bosses serve as basic technological bases. For the purpose of the achievement of good coaxiality of surfaces and a decrease in play of

external surfaces with respect to the fitting hole, the adjusting elements of the devices must be carried out with high accuracy, but installation of the devices on machines should be produced with alignment according to the indicator. The allowed play of adjusting elements to the axis of rotation of the spindle of the machine is 0.01-0.03 mm. Adjusting elements in the form of cylindrical pins or grooves give noticeable errors due to the one-sided clearance, which forms between the pin and fitting hole, as is shown on Fig. 13.3. The maximum error of installation δ is determined by formula

$$\delta = \delta_n + \delta_0 + \Delta,$$

where δ_n - allowance for the manufacture of the pin of the device;
 δ_0 - allowance for the manufacture of the base hole in the disk;
 Δ - guaranteed clearance taken equal 0.02-0.005 mm.

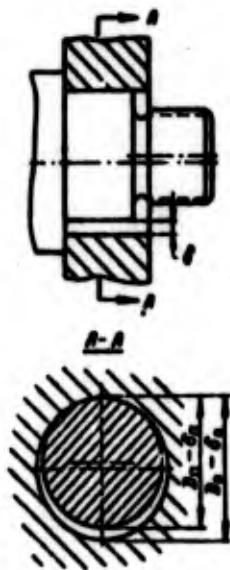

Fig. 13.3. Error of installation on a cylindrical pin.

This error can be equal or even greater than the play than allowed by drawing of external surfaces with respect to the fitting hole. In the installation with such an error the part during machining will revolve around the center, which does not coincide with the center

of the fitting hole, and this error of installation cannot be corrected by grinding. Therefore, for the final machining of external surfaces the disk is installed on elements of the device, which allow selecting evenly the clearance formed.

Such elements are fulfilled in the form of collet, cam or hydroplastic mandrels. As example Fig. 13.4 shows a device for the finishing of face and external surfaces of disks of turbines with installation of the disk on the hydroplastic mandrel. Under the action of pressure of the hydroplastic 10, created by the screw 12, the thin-walled bushing 15 increases its diameter, thereby selecting the fitting clearance. To absorb the torsional moment from forces of cutting the disk 8 to be treated is pressed by nut 13, which acts on washer 9.

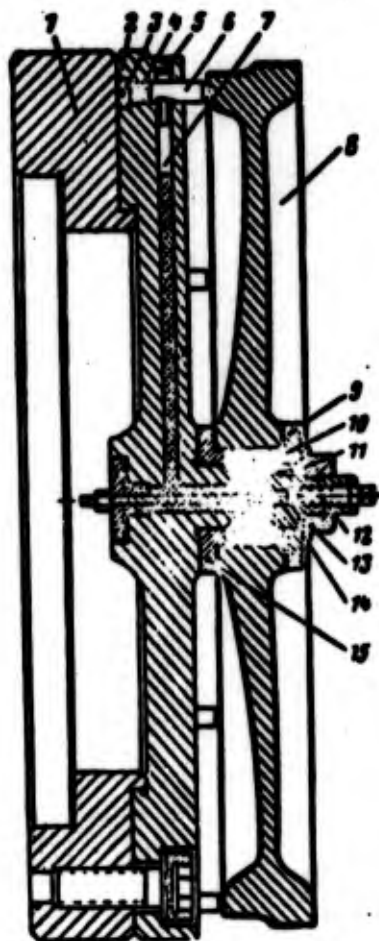

Fig. 13.4. Device for the machining of disks of turbines: 1 - ring; 2 - casing of the device; 3 - screw; 4 - spring; 5 - plug; 6 - set support; 7 - stop; 8 - disk to be treated; 9 - washer; 10 - hydroplastic; 11 - set screw; 12 - working screw; 13 - nut; 14 - plunger; 15 - thin-walled bushing.

To extinguish the vibrations capable of appearing in the process of treatment, self-adjusting set supports 6 are provided. The disk is set on bushing 15 and is slightly pressed by nut 13 and washer 9 (for selection of the axial clearance). Here the set supports 6 under the action of the springs 4 are pressed to the rim of the disk. Then by the wrapping of screw 12 in hydroplastic 10 the design pressure is created. The pressure of the hydroplastic acts both on the thin-walled bushing and on stops 7, which stop the set supports 6. After that final fastening of the disk by nut 13 and washer 9 is produced. To release the disk after its treatment, at first the pressure of the hydroplastic is removed by the unscrewing by several turns of the screw 12, and then nut 13 is unscrewed and washer 9 is removed.

In the finishing stage the formation of grooves for the fastening of blades is also fulfilled. The technology of the formation of grooves and the tool used depend on the design of roots of blades.

Fir-tree grooves (see Fig. 13.1d) in the beginning are milled and then broached. Milling is conducted on a horizontal-milling or gear-milling machine by the method of division. By subsequent broaching machine. Figure 13.5 shows a diagram of finish cutting of annular grooves. Treatment is conducted during three transitions by cutters secured on the turning support.

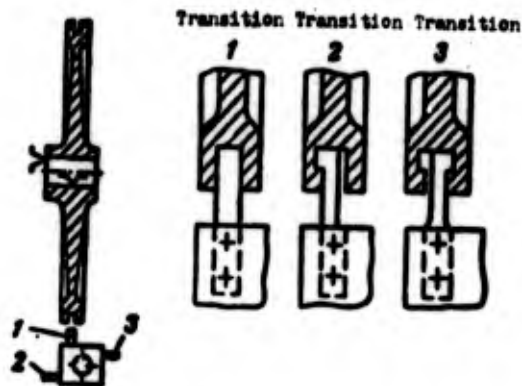

Fig. 13.5. Formation of grooves for the fastening of blades.

Transition 1 - finish cutting of a smooth groove, feed in a direction toward the axis of the disk.

Transition 2 - cutting of the step on one side of the groove. The form cutting tool starts into the groove, and treatment is conducted with longitudinal feed.

Transition 3 - cutting of the step on the other side of the groove. The scheme of treatment is analogous to transition 2.

If the blades are made as one whole with the disk, then in lathe operations final finishing of the boss on the rim under the next blade is produced, and then in subsequent operations the profile of the blades will be formed. The removal of the metal between the blades and the formation of the profile of the blades are fulfilled by ultrasonic, electroerosional and electrochemical methods, which will be discussed in Chapter 14.

With the treatment of disks under welded blades on the rim corresponding bevels for the next seam are turned. The dimensions and configuration of the bevels are assigned drawing of disk.

In the last finishing stage polishing of nonworking parts of the disk, drilling and cutting of the thread of fastening holes, and the formation of a lateral groove for the installation of blades, static balancing and other finishing operations are conducted. Polishing is used for the purpose of increasing the class of cleanness of the surfaces. With polishing a very thin layer of metal is removed, and unevennesses of the preceding treatment are smoothed. Polishing is fulfilled by a soft circle with the application on it of fine-grained abrasive powder mixed with lubrication. The material used for polishing circles is felt, thick felt, and leather.

Instead of polishing circles, it is possible to also use polishing tapes with a layer of abrasive applied to them. Polishing is conducted at a high speed of the polishing circle or polishing tape (up to 40 m/s)

and at a comparatively slow rotation of the part. The process of polishing is conducted most frequently on turning lathes equipped with a polishing head.

The drilling, scanning and cutting of the thread and other forms of treatment of holes located on face surfaces of the disk are fulfilled with the help of conductors on radial-drilling machines.

These machines permit machining any quantity of holes with one installation of the part without its movement in a horizontal plane. By this the saving of auxiliary time is attained.

The treatment of radial holes is conducted on vertical boring machines with the application of turning conductors.

§ 4. Static Balancing

The balancing of disks is fulfilled after all operations of machining for the purpose of exposing the irregularity of the distribution of masses with respect to the axis of rotation of the disk.

Disks of turbines of the turbopump unit usually revolve with a very large number of revolutions, even when a small irregularity in the distribution of the mass causes vibrations impermissible for the operation of the engine.

With the rotation of the disk every element of mass m develops a centrifugal force N , which is determined by equation (Fig. 13.6).

$$N = m\omega^2 R.$$

where $m = \frac{G}{g}$ - mass of the element; ω - angular velocity; R - radius of the circumference on which the element of the mass is located.

If the mass of the revolving disk is distributed evenly, then all centrifugal forces are mutually balanced. If, however, at some places there is an unbalanced mass, then centrifugal forces will also

be unbalanced and produce rotation of this unbalanced force, which will cause vibrations. The magnitude of the force causing the vibration is proportional to the square of the angular velocity and at high revolutions can attain a large magnitude.

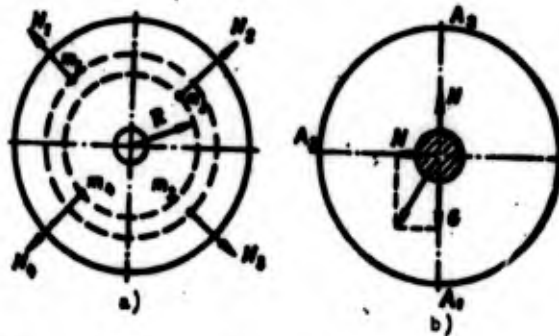

Fig. 13.6. Centrifugal forces in a revolving disk

Table 13.2 gives values of centrifugal force N , appearing from the instability per one gram on a radius equal to one centimeter (or 0.1 g on a radius of 100 mm), depending upon the number of revolutions.

Table 13.2. Value of centrifugal force N appearing from the instability (unbalance) of 1 g on a radius of 1 cm.

Number of revolutions, min	Force		Number of revolutions, min	Force	
	N	g		N	g
500	0.028	2.8	7000	5.55	545
1000	0.11	11.2	10000	11.3	1110
1500	0.25	25	12000	16.3	1600
2000	0.46	45	15000	26.5	2600
3000	1.02	100	18000	36.8	3600
4000	2.02	198	20000	45.5	4450
5000	2.98	280	30000	102.0	10000

As can be seen from the table, even a very small instability of a total of 0.1 g on a radius of 100 mm causes at a speed of rotation of 30,000 r/min an unbalanced centrifugal force of 10 kgf.

With rotation of the disk the unbalanced centrifugal force N will interact with the force of weight G of the disk. At some instant the disk will occupy position A_1 , and the direction of the unbalanced force N coincides with the direction of the force of weight of the disk, as is shown on Fig. 13.6b. Both forces will press the journal of the shaft to the bearing. Then the disk will turn 90° to position A_2 , and force N will be directed at a right angle toward the direction of the force of weight, which somewhat moves the shaft (and disk) to the left. At position A_3 forces N and G are directed oppositely. If force N is larger than the weight of the disk with the shaft, then the shaft with the disk will be raised upwards by the magnitude of the clearance between the journal and bearing, and then with a turn to position A_1 will return to the former position. With large numbers of revolutions these oscillations pass rapidly with impacts, which cause a vibration.

The allowed instability of disks, or unbalance, depends on the number of revolutions. From the condition of the unaccented work of the bearings, an unbalanced inertial force is allowed of not more than half of the force G_{II} of pressure on the bearing from the weight of the rotor. In practice we take $N = (0.2-0.3)G_{II}$.

The basic causes of instability of the disks are the following:

- 1) heterogeneity of the metal in different sections of the disk;
- 2) play of the rim and other parts with respect to the landing hole (or seating boss);
- 3) nonuniform thickness of the disk (one half is somewhat thicker than the opposite due to misalignments with treatment of face surfaces;

4) asymmetric location of holes or unequal distance between centers of the holes, unequal depth of drillings of symmetric holes, etc.;

5) unequal thickness of blades or various distances between the blades (for disks made as one whole with the blades).

The magnitude of the unbalance is measured in g·cm. The problem of balancing consists in the exposure of unbalance and removal of it or in the bringing of unbalance down to the allowed value.

Static balancing of disks is conducted in large-lot and mass productions on special machines and in small-lot production - on simple installations schematically depicted on Fig. 13.7. A disk subjected to balancing is secured on a smooth cylindrical mandrel and set on strictly horizontal cutters (a) or rollers (b) of the balancing installation.

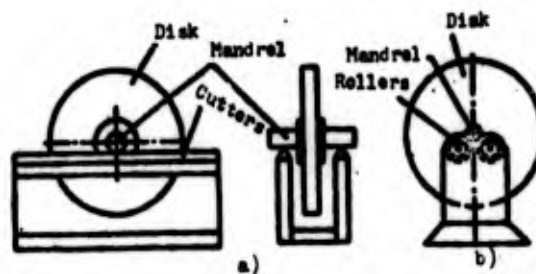

Fig. 13.7. Diagrams of static balancing.

Two methods of static balancing are used: first - when the disk possesses clearly expressed instability, and second - when with respect to external criteria instability is not revealed.

1. To expose the instability the disk is gradually turned, making stops every 15-20°. The unbalanced disk tries to occupy the position of the unbalanced place downwards.

Static balancing is fulfilled in such a sequence:

1) the disk is installed by an assumed unbalanced place downwards, and this position is noted by a vertical line (position I on Fig. 13.8a). The unknown unbalanced load is x ;

2) the disk is turned (rolling along the cutters) by 90° in such a manner that the line noted is disposed horizontally (position II on Fig. 13.8a), and on this line a test load A (for example, a piece of mastic) is secured.

The disk is freed and is made to roll freely over the cutters; it is noted how far the line was turned.

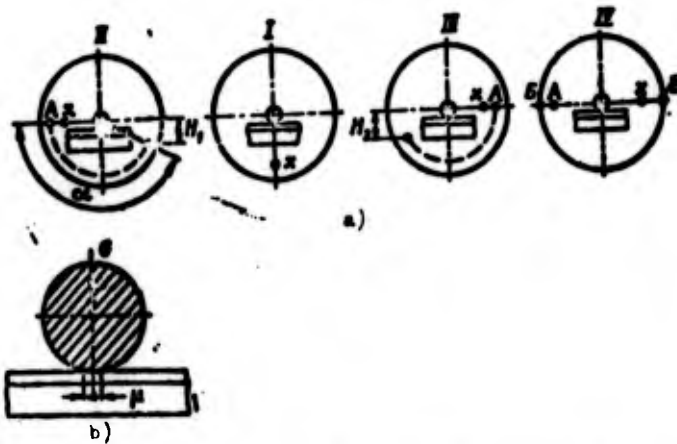

Fig. 13.8. Sequence of static balancing.

By decreasing or increasing the load, we strive to achieve that the angle of rotation be equal approximately to 135° - 140° .

We measure the height H_1 of left of the tested load.

3) the disk is rolled by a test load to the reverse side (position III on Fig. 13.8a), freed, and turned (to rolled), and height H_2 is measured.

Repeating the rolling to one and then the other side and, accordingly, transferring the load, equalities of heights H_1 and H_2 are achieved. In this way the axis of unbalance is established;

4) the disk is set at position IV, as was shown on Fig. 13.8a. Load A is transferred to a diametrically opposite point on the same radius. We add load B on that radius where it is convenient to remove the surplus of metal from the disk. By test rolling and an increase or decrease in the load B such an unbalance as with the former position of load A (equalities of heights H_1 and H_2) is strived for;

5) load B is removed and weighed. The quantity of metal (by weight) which must be removed at place E so that the disk is balanced equal to half of the weight of load B. This is explained by the following. At the first position of load A the unbalanced was caused by load A and the unbalanced conditional load x. At the second position of load A the additional load B balanced load x and still created an unbalance equal to the unbalance caused by load x. Consequently, load B causes an unbalance equal to double the unbalance from load x.

2. The method of bypass along the contour by the control load is more accurate. It is used when with rolling along the cutters the instability is not revealed, which is explained by the presence of friction between the mandrel and balancing cutters. Under the action of the weight of the disk and mandrel the edge of the cutters and mandrel are deformed, forming an area of contact with a width of 2μ (see Fig. 13.8b).

In order to roll disk, it is necessary to overcome the moment of resistance to the rolling

$$M = G\mu,$$

where G - weight of the disk and mandrel; μ - coefficient of rolling friction. With the rolling of a steel mandrel over steel hardened cutters, it is possible to take $\mu = 0.001-0.003$ cm.

Consequently, an unbalance less than this moment of friction cannot be revealed by static balancing according to the first method. Such a disk remains at rest at any position on the balancing cutters.

For balancing according to the second method, the disk is split into several equal parts (6, 8, 12). Points of division are noted by ordinal numeration. All the noted points are alternately reduced into a horizontal plane. At this position for each point there will be selected such a test load under the action of which the disk would make a small turn at the same angle. Point x, at which it was needed to fasten the least load for this, shows that near it the unbalanced mass of the disk is located. Let us assume that the magnitude of this load will be B and D, we find the balancing load y

$$y = \frac{D - B}{2}.$$

The load y found should be removed at point x.

CHAPTER 14

TREATMENT OF BLADES

§ 1. Design, Materials, Specifications

The blade of a gas turbine consists of two basic structural elements - foil and base with a lock. The foil is the working element of the blade, and the base, or lock, serves to connect the foil with disk of the turbine. The foil of the blade has a complex form, which determined by a gas-dynamic calculation. The concave side of the foil is called a trough, and the convex side - back. Profiles of the trough and back are connected, forming edges of the foil: the front, or inlet, edge on the side of the entrance of gas onto the blade and rear, or outlet, edge. Figure 14.1 shows three characteristic types of blades of gas turbines of turbopump unit: a - blade made separately and combinable with the turbine disk by welding or a lock; b - blades of the open type made as one whole with a turbine disk; c - blades made as one whole with the turbine disk united from above by shroud ring.

For each of these types of blades their merits and deficiencies are both of an operational and technological nature.

Blades of the first type are made separately from a disk and can be carried out more accurately and with the best cleanness of surface than can blades of remaining types. Each turbine uses a large number of blades, which permits even with small-lot production of the turbopump

unit organizing continuous manufacture of blades with the application of special equipment and highly productive equipment. However, the necessity of fastening of separately made blades to the disk with the help of locks complicates the technological process and makes the turbine disk heavier. This deficiency to a considerable extent is removed with connection of the blades with the disk by welding.

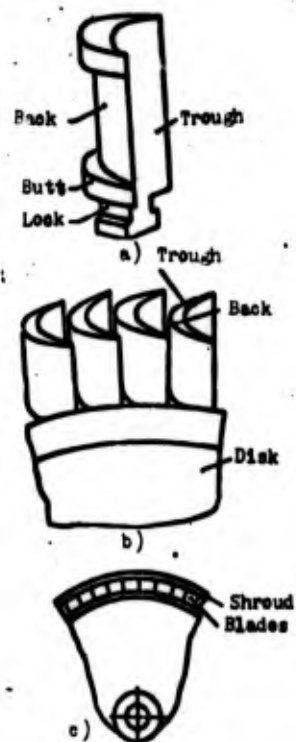

Fig. 14.1. Blades of gas turbines.

Figure 14.2 gives a drawing of a rotor blade of a gas turbine of the turbopump unit [5] welded to a disk. For the formation of a seam on the butt of the blade on both sides, bevels at an angle of 35° are made. For the tight adjoining of blades to one another, with distribution of them on the ring around disk the mating surfaces of the blades are treated at an angle of $3^\circ 36'$ (3.6°). Consequently, the set includes 100 blades $3.6^\circ \times 100 = 360^\circ$. The external diameter of the location of the blades is determined by the dimension 9.41:

$$D_{\text{top}} = \frac{9,41 \cdot 100}{\pi} = 299 \text{ mm.}$$

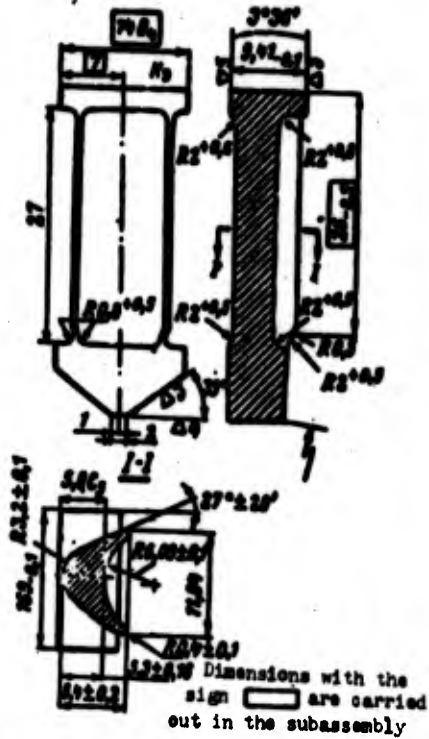

Fig. 14.2. Rotor blade
of the turbine of the
turbopump unit.

With the welding of the blades it is very difficult to obtain identical distances of upper faces of the blades from the center of the disk. Therefore, after welding the external diameter of the blades is machined for which the allowance along the length of the blade is provided. For the same reason the lateral faces of the blades are machined. On Fig. 14.2 dimensions obtained by treatment after welding of the blades (in the subassembly) are included in the rectangles.

Blades of the second type are the most rational in a design sense, since they do not require fastening. However, such blades cannot be prepared by the usual machining. To select the metal between the

blades, it is necessary to use electroerosional, ultrasonic or other methods, which with respect to productivity is considerably inferior to the usual machining. Furthermore, the manufacture of such type of blades requires a very exact observance of the technological process, since the presence of one rejected blade leads to the reject of the entire turbine disk. Blades of the second and third type cannot be made from a metal or alloy different from the metal of the disk (since they form one whole with the disk), which is not always rational and sometimes even impermissible.

Blades of the third type are also rational from a design viewpoint just as blades of the second type. The presence of a shroud, made as one whole with the blades, even improves their characteristic, but the technology of manufacture of such blades does not permit obtaining exact geometric dimensions of the profile of the blades. Casting by a wax pattern gives considerable errors, and the finishing of closed profiles of blades is hindered.

The technological process of manufacture of each of the three types of blades has its peculiarities. A great effect on the technological process is rendered also by the material of the blades.

Blades of gas turbines operate in difficult conditions - at high temperature and high stresses from centrifugal forces. The material of the blades should possess good heat resistance and at the same time are satisfactorily treated by cutting and pressure. The material for cast blades should possess high casting properties. The material of welded blades should weld well with the material of the disk. For manufacture of blades of a turbine the following steels and alloys are used: stainless steel 1Kh18N9T, Cromasil (30KhGSA), steel EI69, heat-resistant alloy VL7-20 and others.

For short-term operation at not very high temperatures, alloys on an aluminum base of the AK4 can be used.

§ 2. Obtaining of Billets

Billets of blades of the first type from deformed materials are obtained by drop forging, extrusion, rolling or another method of deformation. The most exact the billet, with minimum allowances for subsequent machining, can be obtained by flashless die forging in closed stamps with exact proportioning of the metal filled into the stamp. With assignment of allowance, it is possible to follow recommendations of NIATa [Scientific Research Institute of Aviation Technology] [5]:

Table 14.1.

Length of foil of blade, mm	Allowance for the side in mm	
	with respect to the foil	with respect to the lock
Up to 50	0.8-1.0	1.5
From 50 to 100	1.0-1.5	1.5

With accurate observance of the technological process and application of sizing in the protective medium, stamped billets with small allowances for grinding and polishing can be obtained. The technological process of the obtaining of exact billets consists in the preliminary extrusion, double stamping and sizing. The billets are heated in a nonscale medium. After each stamping burrs, barbs and other defects are cleaned, and etching and purification of the surface are conducted. To obtain the most characteristic stamped billets of blades, standard technological processes are developed [1].

The billets of blades from casting alloys are obtained by casting on investment patterns. In many cases the manufacture of castings is more economical than that of stamped castings. With the assignment of tolerances for dimensions and allowances for the treatment, we are

guided by the normal AN 20-80. According to this normal castings are divided into three classes of accuracy - $\Lambda_T 2$, $\Lambda_T 3$, and $\Lambda_T 4$ (the first class of accuracy is attained only by special procedures and is not standardized). The following designations are established:

A - increased accuracy, distance between nonmachined surfaces;

H - normal accuracy, distance between nomachined surfaces;

M - distance from machined to nonmachined surfaces;

Π - coordinates of the profile of the foil of cast blades;

T - thickness of walls of cavities formed by the rods;

P - radii of couplings (noncoordinated).

The designation of the tolerance for the dimension of the cast billet consists in the symbol casting Λ_T , dimension and class of accuracy. For example, $H\Lambda_T 2$ is tolerance for the dimension of the 2nd normal class of accuracy between the nonmachined surfaces; $\Pi\Lambda_T 2$ is tolerance for the dimension of the 2nd class of the profile of the foil of the blade.

The class of accuracy of the castings depends on the technological process of preparation of wax patterns, materials and composition of fillers of forms.

The class of accuracy $\Lambda_T 2$ is obtained in the manufacture of models from alloys of salts on a base of carbamide (urea) and molding with liquid filler in split flasks. The liquid filler consists of a small quartz sand, aluminous cement and water. The class of accuracy $\Lambda_T 3$ is obtained by casting on models from organic masses in forms with a liquid filler. The composition of organic masses includes rosin, polystyrene, paraffin, stearin and cerezin. The class of accuracy $\Lambda_T 4$ is obtained by casting on models from organic masses in a form

with dry filler (fire clay crum, quartz sand and other fireproof materials). Tolerances for machining are designated depending upon the form of treatment, methods of basing and tolerances for dimensions of the part. By the normal AN 20-80 the greatest allowances, given in Table 14.3, are established.

Table 14.2. Allowed deviations of dimensions of cast blades.

Length of airfoil chord, mm	Deviation of thickness of the profile in mm						Length of foil of the blade, mm	Displacement of profile from theoretical axis in mm		Angle of turn of the profile (for all classes of accuracy)
	ЛЛ,2, ЛЛ,3			ЛЛ,4				ЛЛ,2 and ЛЛ,3	ЛЛ,4	
	Within 5 mm from edge, lower	In remaining part of blade		Within 5 mm from the edge, lower	In remaining part of blade					
		upper	lower		upper	lower				
Up to 25	0,10	+0,05	-0,15	0,15	+0,10	-0,25	Up to 50	±0,10	±0,10	10'
Above 25 up to 50	0,15	+0,10	-0,25	0,20	+0,15	-0,30	50-120	±0,15	±0,15	10'
Above 50 up to 80	0,20	+0,15	-0,30	0,25	+0,25	-0,40	-	-	-	-

Table 14.3. The greatest allowances for the machining of castings fulfilled according to the normal AN 20-80.

Nominal dimension of casting in mm	Allowance for one side in mm		
	Л _Т 2	Л _Т 3	Л _Т 4
Up to 30	0.5	1.0	1.0
Above 30 up to 50	0.5	1.0	1.5
Above 50 up to 80	0.7	1.5	1.5
Above 80 up to 120	1.0	1.5	2.0
Above 120 up to 200	1.5	2.0	2.5
Above 200 up to 250	2.0	2.5	3.0

Blades of the second type are prepared as one whole with the turbine disk. During calculation of the billet of the disk, the corresponding allowance for the formation of the blade is provided. Blades of the third type are cast together with the turbine disk. A corresponding allowance for treatment along the profile of the blade is provided. Allowed deviations of dimensions of cast are taken according to the normal AN 20-80.

§ 3. Methods of Treatment

The technological method of the treatment of blades depends on the type of blade, form of billet and workability of the material.

With treatment of blades of the first type the correct selection of adjusting bases is important. The complex form and insufficient rigidity of the blade hamper its installation and fastening in the device. With incorrect installation of the blade with small allowances along the foil, a nonuniform removal of the metal is obtained, and in separate places untreated surfaces (blackness) can appear. In order to distribute evenly the allowance along the foil of the blade, it is necessary to install each blade in the most advantageous position in accordance with the actual configuration of the billet. This is possible when the position of support elements of the device is changed. For realization of such an installation there are special devices of automatic distribution of the allowance of the ARP type. With the help of these devices the automatic search of the optimum location of the blade according to the assigned number of degrees freedom (up to 6 degrees) is conducted.

The device ARP [5] consists of two parts. The first (is located in a cabinet) contains a unit of criterion formation, an optimizing device, a switching unit and feed unit. The second part consists of platforms for installation of the blade with mechanisms of its movement according to the assigned number of degrees of freedom and clips for the installation of inductance pickups on the surface of the foil of the blade. The pickups are preliminarily tuned according

to the standard blade. As a result of automatic search the billet is disposed with equal distribution of the allowance with respect to the contour of the standard blade. The accuracy of installation of the blade is 0.05-0.2 mm. The time of the search of the most advantageous position is 12-30 s. Upon the completion of the search, the device automatically stops. If the billet has an impermissible deviation from the standard, it is automatically rejected.

After machining of the foil of the blade from cast or stamped billets with small allowances, warping of the blade occurs as a result of the redistribution of residual internal stresses in the material of the billet after removal of the surface layer and action of stresses on the machined surface, which appear in the process of cutting. Usually these warpings are small, and it is possible to remove or considerably to decrease them by the selection of appropriate conditions of cutting. In certain cases correction of the installation of the blade with such calculation is required so that after warping the treated blade takes the necessary form.

With treatment of the butt, upper shelf and lateral faces of the blades, taken for the base is the foil of the blade, the low rigidity of which does not permit reliably securing the blade. To increase the rigidity of the foil, it is filled with a fusible alloy of the type of Wood's alloy. Such a method permits rigidly fastening the blade in the device and avoiding warping of the foil under the action of forces of cutting.

Machining of the blades from heat-resistant alloys, which possess high strength and, at the same time, high viscosity, is accompanied by surface hardening of the alloy, which leads to a growth in forces of cutting, rapid heating and wear of the tool. Therefore, it is recommended to use grinding and electroerosional methods of treatment of blades more extensively.

Approximate Method of Treatment of Short
Blades with a T-Shaped Root
(See Fig. 14.1a)

1. Accurate stamping or casting with an allowance along the foil of 0.5-0.8 mm for the side.
2. Machining of the shroud shelf and butt part with basing along the back and clamp on the side of the trough.
3. Consecutive grinding of lateral surfaces of the shroud shelf and butt on the side of the back, trough, and leading and trailing edges.
4. Grinding of the trough.
5. Grinding of the back.
6. Assembly of a set of blades in a special device.
7. Turning of the root.

Approximate Method of Treatment of Blades
with Fir-Tree Root

1. Accurate stamping of the billet with an allowance for the side of 0.5-0.8 mm along the foil and 10 mm along the root.
2. Milling of the leading and trailing edges.
3. Equal distribution of the allowance along the foil and filling with a light alloy in the holder.
4. Milling and grinding of base surfaces of the root and upper shelf, faces of the root and shelf.

5. Milling of the wedge and profile of the root.
6. Grinding of bevels of the root and shelf.
7. Smelting of the alloy and removal of the blade from holder.
8. Electroerosional treatment of the foil.
9. Electrohydropolishing.
10. Grinding of leading and trailing edges.
11. Hydroabrasive polishing of the foil.
12. Etching and control of defects.
13. Hydroabrasive polishing of the foil.
14. Polishing of edges of the foil by abrasive tape.
15. Grinding of the labyrinth on the upper shelf.
16. Final control.

In the manufacture of blades combinable with the disk by welding, there is no need for treatment of the root. Such blades are treated along the surface of the foil and then along lateral surfaces of the shroud shelf and butt of the blade on the side of the back, trough, and leading and trailing edges. After this the set of blades is fastened to one disk in a special device in the position that they will occupy in the turbine disk, they are tightened, and butt part of the blades is turned for welding.

The blades of the second and third types, which are made as one whole with the turbine disk, are treated basically by electrical methods. Lateral surfaces and the shroud are subjected to machining. These processes are fulfilled simultaneously with the treatment of the turbine disk.

§ 4. Fulfillment of Basic Operations

Preliminary machining of the foil of blades of the first type from the billets with great allowances consists in grinding or milling. Treatment is conducted in several operations with a gradual approach to the assigned dimensions, since the low rigidity and possible warping do not permit removing the whole allowance in one operation.

The section of the foil of short blades of turbines of the turbopump unit is usually constant in length, which facilitates their treatment. The trough of such blades is machined by a form cutter with longitudinal feed of the blade. A diagram of the milling of the trough is shown on Fig. 14.3. The profile of the milling cutter for clean milling corresponds to the profile of the trough of the blade with a small decrease in dimensions - in such a way as to obtain an allowance of 0.2-0.3 mm with respect to the trough for subsequent grinding. The profile of the milling cutter for preliminary milling of the trough is fulfilled from the condition of the leaving of an allowance for clean milling. The treatment of the trough of long blades, which have a section of the foil variable in length, is conducted on duplicating milling machines, the principle of operation of which will be examined below.

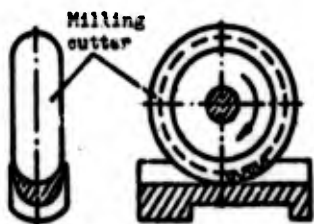

Fig. 14.3. Diagram of milling of the trough of the foil of the blade.

The back of the foil of the blades has a complex profile and is machined by grinding or milling with respect to the copy. Schematic diagrams of treatment of the back are shown on Fig. 14.4.

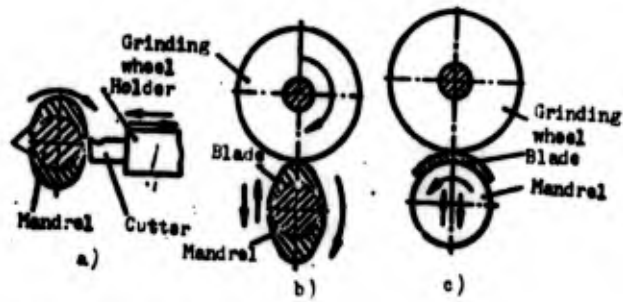

Fig. 14.4. Diagrams of treatment of the back of a blade foil.

Diagram a shows treatment of the back by grinding. Secured on the mandrel are two blades to be treated. The form of the mandrel is fulfilled with such calculation that the external treated surfaces of backs of the blades are disposed as near as possible to the circumference. This is done for the purpose of decreasing movement of the copy device and for improvement of conditions of cutting. With considerable deflections of surfaces to be treated from circumference, the angles of cutting greatly change, which unfavorably affects conditions of treatment. The mandrel, together with blades secured on it, revolves, and the cutter under the action of the copy device accomplishes a reciprocating motion, first approaching, then departing from the center of rotation of the mandrel. The motion of the cutter is synchronized with rotation of the mandrel. As a result of the addition of two motions the cutting edge of the cutter describes the assigned curve of the back of the foil of the blade. Treatment by grinding can be fulfilled on a lathe or turret lathe equipped with a duplicator. Special lathe-copying semiautomatic machines are more adapted for these purposes.

With respect to diagram a it is possible also to mill or grind the back of the blade. For this on the mandrel of the duplicator, instead of a cutter, it is necessary to place a revolving milling cutter or grinding wheel.

However, it is expedient to mill or grind with a fixed axis of the revolving milling cutter (or revolving grinding wheel). A diagram of such treatment is shown on Fig. 14.4b. The blades to be treated revolve together with the mandrel and simultaneously accomplish a reciprocating motion, first approaching to the milling cutter, then departing from it (or to the grinding wheel). The reciprocating motion of the mandrel is synchronized with its rotation.

Figure 14.4c shows a diagram of the milling or grinding of a back without rotation of the blade. The mandrel, together with the blades secured on it, accomplishes an oscillatory and simultaneously reciprocating motion, first departing, then approaching to the revolving milling cutter or grinding wheel. With this scheme it is possible to treat not only convex backs, but also concave surfaces of the trough of the blade, since the part does not revolve. By this method it is possible also to treat complex profiles of the back and trough of the foil with a twist or section variable in length, since, besides the oscillatory and reciprocating motions, in the process of treatment it is possible to change the position of the axis of the mandrel (incline upwards, downwards, to the right, and to the left). Special machines of the type of milling copying semiautomatic machine OF-31M operate on this scheme [1].

Treatment of the butt and shroud shelf of the blades is fulfilled by standard milling with basing on the foil. With low rigidity of the foil measures are taken to create artificial rigidity, for example, by location into special holders with the filling of Wood's fusible alloy. For the purpose of increasing the productivity special multiseater devices are used.

Blades of the first type are fastened to the disk of the turbine by a root or are welded. For root bracing on the rim of the disk there is made an annular groove, into which through a special cut the blades are started and are tightly pressed to each other. For such fastening it is necessary that the root of the blade be formed not by straight lines but arcs of the same radius as the annular groove

on the turbine disk (Fig. 14.5a). For treatment of such roots a whole set of blades going on the rotor of the turbine is installed in a special device in such a position which they will occupy in the turbine disk and is secured. Then the assigned profile of the root is turned simultaneously for all blades. Figure 14.5b gives a diagram of the lathe device for treatment of roots of blades. The blades 2 to be treated are set into the annular recess in housing 3 and are secured by a clamping ring 4.

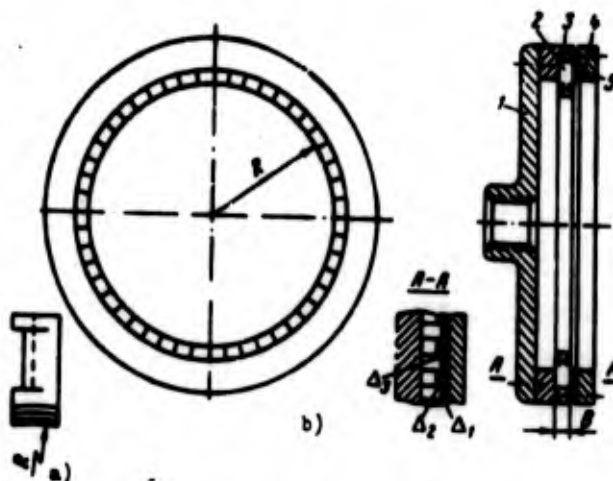

Fig. 14.5. Treatment of the root of blades: 1 - face plate; 2 - set of blades to be treated; 3 - casing of the device; 4 - clamping ring; 5 - packing.

Due to an error in the manufacture of the blades, the dimension B of every blade will differ from dimension B of other blades entering into the set (within limits of the allowance for manufacture of dimension B). Consequently, it is impossible to secure simultaneously all blades to one rigid ring 4, since clearances $\Delta_1, \Delta_2, \Delta_3, \dots$ will be different (see section A-A). In such cases multiple clamps are used.

With great oscillation of dimension B a hydroplastic clamp with plungers located opposite the blades is used; the hydroplastic presses on the plungers. With small oscillation of the dimension B, it is possible to set between the blades and clamping ring packing 5, as is shown Fig. 14.5b. Due to the deformation of the packing small clearances $\Delta_1, \Delta_2, \Delta_3, \dots$ will be selected, and all blades will be secured. The material of the packing should be elastic and reliably secure the blades.

In the same device treatment of the butt of the blades is conducted with connection of them to the disk by welding. The form of dressing of edges of the butt of blades for welding is assigned proceeding from conditions of the formation of the welded seam.

Besides the machining of blades, other forms of treatment, in particular, electrical, are used (see § 6 of this chapter).

§ 5. Finishing Operations

Finishing operations have a considerable effect on the efficiency of blades. With poor finishing on the surface of the blade traces of preceding machining in the form of notches, small surface cracks and other defects remain, and these serve as concentrators of stresses and lower the fatigue strength of the blade. One of the main problems of finishing consists in the removal of these defects and in the bringing of the cleanness of the surface to that assigned by the drawing. However, fatigue strength depends not only on the cleanness of the surface, but also on the physical and mechanical state of the surface layer of material of the blade: work hardening and residual stresses (tensile or compressive). The thickness of the workhardened layer and sign of residual stresses depend on the tool used and conditions of treatment. With an increase in speed of the cutting, the depth and degree of work hardening decrease. With an increase in feed and with blunting of the cutting edge, work hardening is increased.

As a result of treatment by cutting, in the surface layer tensile residual stresses usually appear. Grinding and polishing by abrasive belt creates in the surface layer compressive residual stresses. Grinding with ceramic wheels can create tensile residual stresses. Residual stresses can attain considerable magnitudes. For example, in the surface layer of the foil of blades of a turbine of alloy EI867 with grinding with ceramic wheels and polishing with flexible polishers, tensile residual stresses of $350-700 \text{ MN/m}^2$ ($35-70 \text{ kgf/mm}^2$). Grinding and polishing by an abrasive belt creates in the surface layer compressive stresses of $400-800 \text{ MN/m}^2$ ($40-80 \text{ kgf/mm}^2$) [5].

With operation of the turbine great tensile stresses from the action of centrifugal forces appear in the blades. If, however, in the surface layer of the blades there are residual tensile stresses, they are added to stresses from centrifugal forces, and the total stresses can exceed the permissible values. Consequently, tensile residual stresses are harmful. On the other hand, compressive residual stresses during a defined time prove to be useful, since, being folded (with reverse sign) to the tensile stresses from centrifugal forces, they decrease the total stress. From what has been said one can see how important it is to select the most expedient technological process of finishing of the surface of blades.

The following technological methods of increasing the service life and operational reliability of blades are recommended [1]:

1. Mechanization and automation of treatment, in the first place, operations of final finishing of the foil. Exclusion of manual treatment permits increasing the stability of quality of the surface layer.

2. The selection of methods and conditions treatment proceeding from conditions of providing the greatest strength of the blades. Optimum conditions of treatment should be designated for every concrete case, taking into account the accumulated data on the dependence of strength characteristics of blades on the quality of the surface layer.

3. Application of strengthening treatments: shot blasting, hydraulic tumbling, vibration tumbling, rolling with rollers or balls.

4. Additional tempering for blades of turbines after final treatment of the foil for the purpose of decreasing residual stresses. Conditions of heat treatment are designated proceeding from accumulated experience.

5. Heat-resistant protective coverings for the protection of the surface layer of blades of turbines.

Let us examine some of the most characteristic finishing operations.

Grinding with an abrasive wheel. Grinding is usually fulfilled in two operations - preliminary and finish. The trough, which has a constant cross section along length of the foil, is ground by a profiled abrasive wheel. A diagram of grinding of a trough is shown on Fig. 14.6. Secured in the device are simultaneously two, three and more blades, which accomplish reciprocating motion along the tangent to the revolving grinding wheel. Feed in a radial direction (incision) to the center the grinding wheel is simultaneously carried out. Preliminary grinding differs from finish only by the quality of the grinding wheels and conditions of treatment. For preliminary grinding grinding wheels with bigger abrasive grains are used, and finish grinding is fulfilled by fine-grained wheels with small feeds and abundant cooling. The granularity of the grinding wheel, speed of grinding and magnitude of feed will be selected in every concrete case taking into account the material and design of the blade.

Grinding by an abrasive wheel (preliminary and finish) of the back of the foil of the blades is conducted with the application of copy devices. The diagram of grinding according to the master form is analogous to diagrams of milling depicted on Fig. 14.4.

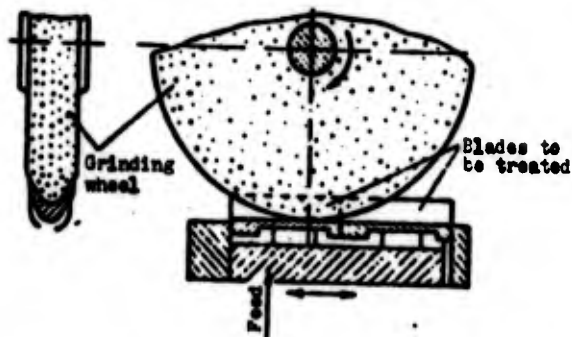

Fig. 14.6. Diagram of grinding of the trough of blade.

Grinding by an abrasive belt. With grinding of the foil of the blade it is sometimes expedient in exchange for the rigid grinding wheel to use a flexible abrasive belt.

The abrasive belt has three layers: first - average carrying layer, called by the base, is made of durable tissue (coarse calico, serge, diagonal); second - the working layer consists of abrasive grains fastened to each other with the basic elastic cluster; third layer - of a material possessing a small coefficient of sliding friction applied on the base on the side opposite the working abrasive layer. This third layer is called dressing.

A diagram of grinding by an abrasive strip are shown on Fig. 14.7. The endless abrasive strip moves between the surface of the blade to be treated and the cam. The abrasive layer is turned to blade and the dressing - to the cam. With motion of the cam in the direction of the blade the abrasive belt with grind surface. To ensure grinding over the entire surface of the trough (a) or back (b) of the blade, the latter in the process of treatment rocks and shifts. The cam can also rock. As a result of combination of motions, a uniform removal of metal over the whole ground surface is ensured. Grinding by an abrasive strip has the following merits.

1. The profile of the blade after grinding is determined by the form of cam and kinematics of the machine and practically does not depend on the wear of the abrasive belt. Consequently, a higher accuracy of dimensions is attained than with grinding by an abrasive wheel. Errors when grinding with an abrasive wheel are caused by its nonuniform wear. For the purpose of correcting these errors it is necessary systematically to guide the wheel and make an adjustment on its new (decreased) dimension.



Fig. 14.7. Diagram of grinding with an abrasive belt.

2. The speed of grinding does not depend on the wear of the abrasive layer of the belt, and consequently, conditions of treatment are not changed. With grinding by the abrasive wheel after every correction its diameter decreases, and after a large number of corrections the speed of grinding also considerably decreases (at a constant number of revolutions of the wheel), which has an effect on the quality of grinding and productivity.

3. It is simpler to replace the belt than the grinding wheel.

4. Due to the elasticity of the grinding belt conditions of removal of metal are better than when grinding with a rigid abrasive wheel. When grinding by an abrasive belt with abundant cooling in the surface layer of the foil of the blade compressive residual stresses, which favorably affect the fatigue strength of the blades appear. Grinding by a rigid abrasive wheel in most cases is accompanied by the appearance of harmful tensile stresses in the surface layer of the blades.

When grinding by an abrasive belt high accuracy of treatment (along the profile of the foil up to 0.05 mm) and good cleanness of the surface (V7-V8) are attained.

For grinding by an abrasive strip special machines are manufactured.

Polishing permits obtaining a cleanness of the surface of the foil of blades of V9-V11. Depending upon concrete conditions, mechanical, abrasive-liquid or electrolytic polishing are used.

Mechanical polishing is carried out by a fine-grained abrasive powder mixed with lubrication. Industry manufactures special polishing pastes, which include, besides abrasive dust, chemically active substances, which accelerate the process of polishing. Polishing paste is applied to a soft polishing wheel or to a polishing belt. Machines for polishing by a belt can work on the same principle as can machines for grinding with abrasive belt. Machines for polishing by a fixed polishing tape pressed to the vibrating blade are also used. Machines LVP-3, LVP-4, VPL-4 and others work on such a principle.

Figure 14.8 depicts a schematic diagram of a machine for vibration polishing of a foil of a blade.

The blade 1 to be treated is installed by the foil downwards between two polishing belts 4 and is secured by own lock in grip 9. Under the action of hydrocylinders 3 the belts are tightly pressed to the foil of the blade by rubber blocks, which are made in the reflected form of the foil of the blade. Then drive of the vibrator 6 is switched on, which through rod 7 and grip 9 imparts to the blade a rapid reciprocating motion of small stroke. In this case the polishing belts are stationary. Polishing occurs as a result of friction of the surface of the foil of the blade against the fixed belt pressed to it, on which paste with a fine-grained abrasive is applied. After the termination of polishing, the hydrocylinders 3 deflect shoes 2, and grip 9 opens, releasing the blade. Before installation of the next blade the polishing belt is stretched by rollers 10 to the necessary magnitude so that polishing will be conducted by the new section of the belt.

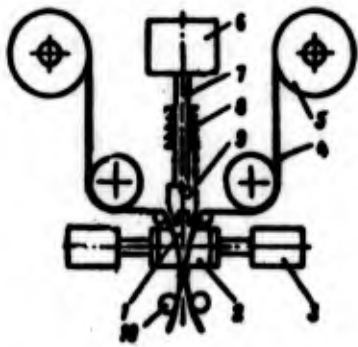

Fig. 14.8. Diagram of the machine for vibration polishing of the foil of blades: 1 - blade; 2 - shoe; 3 - hydrocylinder; 4 - polishing strip; 5 - coil of the strip; 6 - mechanism of the vibrator; 7 - rod; 7 - guide of the rod; 9 - grip; 10 - stretching rollers.

Polishing abrasive tapes are manufactured by industry according to appropriate standards.

For the preliminary polishing of steel blades an abrasive strip E70 on a paper base (All Union Government Standard 6456-62) is used. For the second transition the abrasive strip E150 also on a paper base (All Union Government Standard 6456-62) is used. For final polishing in the third transition the strip E22 on tissue base (All Union Government Standard 5009-62) with paste GOI is used. The total allowance for polishing is usually 0.02-0.03 mm to the side.

Abrasive-liquid polishing is carried out by small abrasive grains suspended in oil, soda solution or other liquid. The quantity of the abrasive is from 25 to 40% of the weight of the liquid. The mixture is thoroughly and continuously mixed for equal distribution of grains of the abrasive all along volumes and under pressure is guided to the polished surface. Polishing occurs as a result of a large quantity of impacts of the abrasive grains and chemical effect of the liquid.

The polishing mixture flows out through the nozzle inclined to the polished surface at an angle of 15°-45° so that the stream of the mixture slips over the surface. For uniform treatment of the whole surface, the nozzle slowly moves.

For a more uniform treatment of the surface, sometimes together with the liquid a stream of compressed air is blown into the nozzle, as a result of which there occurs splitting of the stream with the formation of a spray cone. The optimum pressure of the air depends on the granularity (coarseness) of the abrasive and varies from 1 to 10 atmospheres.

§ 6. Electrical and Other Methods of Treatment

Removal of the allowance from the billet and formation of the form of the part can be carried out not only by machining, but also by other methods: electrical, electrochemical, ultrasonic. The application of nonmechanical methods of treatment is expedient in those cases when machining is hampered or even impossible because of the high hardness of the material to be treated or for other considerations. In practice the following nonmechanical methods of treatment have found application.

The electroerosional method is based on thermal action of pulses of electrical current fed directly into the zone of treatment. Pulses of short duration (less than 0.01 s) are fed to the electrode and part by an electrical pulse generator. Short-term electric discharge creates in the zone of treatment (in zone of discharge) high temperatures, up to 10,000°C, as a result of which the material is destroyed and partially evaporates. A schematic diagram of the electroerosional treatment is shown on Fig. 14.9. The electrode-tool is made in a reflected form of the surface of the blade to be treated, taking into account a certain clearance between the blade and the tool.

The electrode is installed at a small distance (0.13-0.18 mm) from the surface of the blade. With feed of the electrical pulse between the electrode and the blade a discharge, accompanied by the destruction of the metal of the blade (electroerosion), occurs. With destruction of the metal the electrode gradually moves toward the blade, cutting into it. Treatment is conducted in a liquid dielectric:

transformer or solar oil. Products of destruction of metal contaminate the oil, which lowers the productivity and stability of the process. Therefore, the oil is systematically cleaned or replaced.

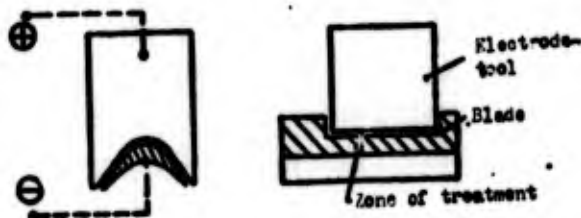

Fig. 14.9. Electroerosional treatment of blades.

The electroerosional method is divided into two varieties: electrosark and electropulse.

A diagram of the electrosark treatment is given on Fig. 14.10a. The working electrical circuit obtains power from a condensing generator. In such a circuit the amplitude, duration of discharge, and the polarity and frequency of pulses produced by generator depend on the physical state of the erosional interval.

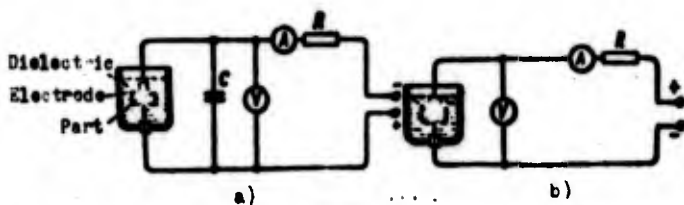

Fig. 14.10. Schematic diagram of the electroerosional method of treatment.

A diagram of the electropulse treatment is shown on Fig. 14.10b. The working circuit is fed from an independent generator of electrical pulses. The amplitude, duration and frequency of the pulses do not depend on the state of the erosional interval.

The electroerosional method is used for treatment of the foil of blades from heat-resistant steels and alloys. Cleanness of the surface after treatment depends on conditions of the treatment and varies from V1 to V5. For illustration Table 14.4 gives conditions of treatment and obtainable technological indices [1].

Table 14.4. Conditions and technological indices of the electropulse treatment of heat-resistant steels using generators MGI-2 and MGI-3.

Conditions	Voltage, V	Current intensity, A	Power-drain, W	Productivity, mm ³ per min	Class of cleanness of surface	Depth of modified layer mm
Mild	20-25	3-10	90-180	70-130	3-4	0.1-0.14
Medium		20-30	560	400	2	0.2
Rough		60-100	1330-2100	1000-1500	1.	0.3-0.45

After electroerosional treatment on the surface of the blades there will be formed a modified (fused) layer with different inclusions, crumblings, cracks, which lower the fatigue strength of the blades by 30-40%. The thickness of this layer depends on conditions of the treatment and is 0.1-0.45 mm. Therefore, the electroerosional method is used only for preliminary treatment of the profile of the foil of the blade. In subsequent operations this layer certainly departs. The allowance for subsequent treatment should be two-three times more than the depth of the modified layer.

By the electroerosional method blades are treated on special machines or on universal copying-piercing machines for electroerosional treatment. The electrode-tool is made from materials possessing good stability, for example, ARV or EEG. The wear of electrodes from these

materials is 0.2-1.0% of the volume of the metal, remote in the process of treatment. Such small wear permits treating 20-30 blades by one electrode, after which it is necessary to restore the profile of the electrode.

Treatment is usually conducted in various conditions: for removal of the main part of the allowance rough or average conditions, and at the end of treatment - mild conditions are used.

After electroerosional treatment grinding and polishing of the surface by an abrasive strip are conducted, or electrochemical treatment with subsequent polishing is used.

Electrochemical treatment. The principal scheme of the dimensional electro-chemical treatment of the blades is shown on Fig. 14.11. The blade to be treated is set between the electrode-tools in such a manner so that between surfaces of the blade and tool a clearance of 0.1-0.4 mm is formed. Through this clearance an electrolyte is pumped at high speed. The blade and electrode-tool are connected with a source of direct electrical current. Here the part (blade) is the anode and the electrode-tool - the cathode. With the passage of electrical current the surface of the anode (part to be treated) is washed by the electrolyte, and the surface layer is dissolved, and products of dissolution continuously depart by a flow of electrolyte and are deposited in a cleaning device. The electrode-tool, which is the cathode, is not worn out. The part to be treated takes its form. The intensity of removal of the metal, other things being equal, depends on the magnitude of the clearance between the blade and electrode. The electrode-tool is made of stainless steel (for example, Kh19N9T). As an electrolyte a solution of common salt (NaCl) is used.

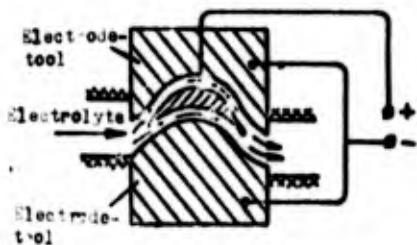

Fig. 14.11. Electrochemical treatment of blades.

Treatment is conducted on special machines of the type EGS, EKHO and AGE. The time of treatment depends on the current density, which is within $10-30 \text{ A/cm}^2$ at a voltage of 12 V. Tentatively one can assume that in one minute a layer of metal 0.15-0.20 mm is taken from the surface of the blade. The cleanness of treatment corresponds to the 7th-8th classes. After electrochemical treatment in the surface layer of the treated metal residual stresses do not appear and the hardness of the layer does not differ from the hardness of basic metal.

To increase the cleanness of the surface of the blades, after electrochemical dimensional treatment polishing by an abrasive belt or electrolytic polishing are used.

Electrolytic polishing. The method is based on the phenomenon of dissolution of the surface of metal of the anode in the process of electrolysis. In this case the protruding microroughness (combs) of surface are dissolved, and in cavities a viscous film of salts is formed, protecting them from the action of the electrolyte. As a result the roughness of the surface is smoothed. Electrolytic polishing is produced in a sulfuric-phosphoric or sulfuric-phosphoric chromium electrolytes at a temperature of $15-30^\circ\text{C}$. The current density is $40-80 \text{ A/dm}^2$.

The thickness of the layer of metal taken is 0.03-0.05 mm, and the cleanness of the surface corresponds to 10-11th classes.

Ultrasonic treatment. A schematic diagram of a machine for ultrasonic treatment is shown on Fig. 14.12. Given to tool 5 are reciprocating high-frequency oscillations by the magnetostrictive converter 6. The article 4 to be treated is found in the bath 3.

Feed continuously into the zone of treatment is an abrasive suspension (suspension of small abrasive in water). Under the action of the fluctuating tool grains of the abrasive exert an effect on the surface of the part to be treated and destroy it. With destruction the tool moves by a mechanism of the feed 7 system to the part. The tool

is made of viscous steel, carbon or rust-resistant. The form of the tool is made according to the reflected form of the part.

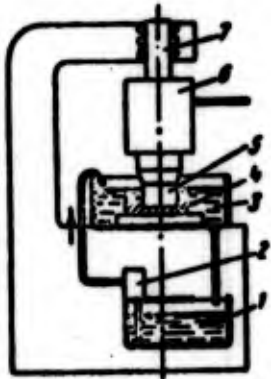

Fig. 14.12. Diagram of a machine for ultrasonic treatment: 1 - tank for abrasive suspension; 2 - feed pump of abrasive suspension; 3 - bath; 4 - part to be treated; 5 - tool; 6 - magnetostrictive converter; 7 - feed system.

For preparation of the suspension different abrasive powders are used: diamond, boron carbide, silicon carbide, electrocorundum and others. The best result is given by the diamond abrasive.

Ultrasonic treatment is expedient in the manufacture of parts from very hard materials and alloys or steels hardened to high hardness. With treatment by ultrasonics of soft materials (copper, soft steels), grains of the abrasive are introduced into the material, not causing its destruction. Therefore, soft materials in practice by ultrasonics are not treated.

§ 7. Control of Blades

In the process of manufacture the blades are subjected to thorough technical control for the purpose of installation:

- 1) absence of impermissible defects of the material;
- 2) correspondence of actual geometric dimensions of the blade by the assigned drawing;

3) determination of cleanness of the surface.

Defects of the material are revealed the same methods which are used for the control of quality of welded seams (examined in Chapter 5). To reveal surface defects, the most widespread is the dye method (or colored method), as is the simplest in industrial conditions. Ferromagnetic and luminescent methods are also used.

To expose internal defects of the material, more frequently than others the ultrasonic method of control is used. The magnitude and nature of the allowed surface and internal defects are assigned by technical conditions for manufacture of blades, which are composed on the basis of data of calculation and tests both on samples and under conditions of operation.

The control of geometric dimensions of the foil and the root at small scales of production is carried out by a set of rigid measuring tools in the form of maximum clamps and patterns and also by the simplest indicator instruments. Deviation of the curvilinear profile of the foil of the blade from the profile of the pattern is checked visually by an opening or by a thickness gage. The application of a thickness gage for determination of the magnitude of clearance on curvilinear sections is not always possible, and with visual control it is impossible to determine the exact value of the clearance. Control with the help of patterns is not very productive.

With a great program of the manufacture of blades, it is expedient to use highly productive special measuring instruments. Wide practical application has been found in instruments in which the following methods of measurement are used:

- 1) contact method;
- 2) optical, or method of light cross section;
- 3) contactless method of measurement by pneumatic transducers.

Instruments founded on the contact method have transducers, which touch the surface of the blade. The zero position of the transducers is tuned according to the standard (standard blade). With deviation of the controlled blade from the dimension of the standard, the transducers will obtain movement, which can be measured. Movement of the transducers can be measured by mechanical, electrical light, inductive and other methods.

Figure 14.13 shows a diagram of contact measurement of the profile of the foil of the blade with the help of indicators of the dial type. The instrument is tuned according to standard instrument set at the place of the blade 6. Here the pointers of indicators 1-5 occupy a zero position (or somewhat in advance of the assigned, for example, 1 mm). Upon measurement the controlled blade 6 occupies the position shown on the figure. If the profile of the blade has deviation from the profile of the standard, depicted on the figure by a thin line, as, for example, at places A and B then transducers 7 will move, which will be shown by indicator 1-5.

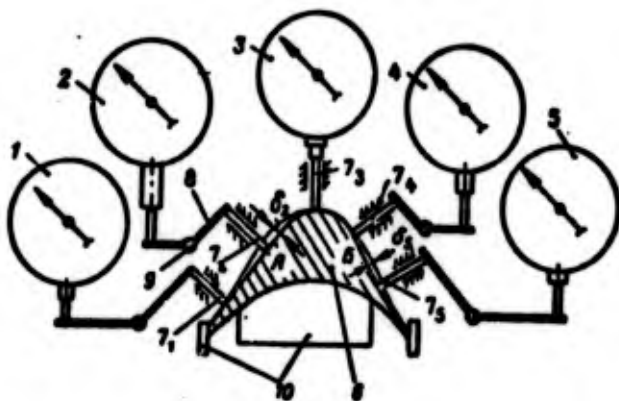

Fig. 14.13. Diagram of the contact method of measurement of geometric dimensions of a blade: 1, 2, 3, 4, 5 - indicators; 6 - measured blades; 7₁, 7₂, 7₃, 7₄, 7₅ - transducers; 8 - two-arm levers; 9 - fixed axis of the levers; 10 - adjusting elements of the instrument.

On the figure transducers 7_1 , 7_3 , and 7_4 occupy the zero position. At place A transducer 7_2 will move by the magnitude of error of the profile δ_2 . In this case the double-shoulder lever 8 will turn around the fixed axis 9, which will cause movement of the rod of indicator 2. If the arms of the lever 8 are of identical length, then movement of the rod of the indicator will be exactly equal to the movement of the transducer. Consequently, the countdown of the error δ_2 can be produced directly along the scale of the indicator.

As can be seen from the figure, measurement is produced in points under the transducers. The quantity of installed transducers is determined by the quantity of points subject to measurement.

Figure 14.14 shows a diagram of the instrument for control of the profile of the foil of the blade founded on the optical method. The controlled blade 5 is installed on table 1 of the instrument and is fastened by the foil upward. The blade foil is preliminarily covered by a layer of magnesium soot so that the surface does not reflect light rays. The blade on all sides is intensively illuminated by light sources 3. To form parallel beams of light lens 4 is installed. The image of the contour of the blade is reflected in adjustable mirrors 2 and enters into the ring-shaped lens 6.

The presence of the hole in lens 6 permits controlling long parts. The image of the profile of the blade amplified by the lens is reflected by mirrors 7 and 9 and observed on screen 8. Usually a 20-fold amplification of dimensions is taken, but greater amplification can be obtained. On screen the theoretical profile of the blade is traced. Control is carried out visually with respect to deviation of the profile of the blade from the theoretical. On screen lines of the field of allowance are drawn equidistant to the theoretical profile.

A diagram of control by pneumatic transducers is shown on Fig. 14.15. Pneumatic transducers lead up to the measured blade. Every transducer has the form of a nozzle from which air emanates. The quantity of air emanating from the nozzle is proportional to the clearance between the nozzle and surface of the blade.

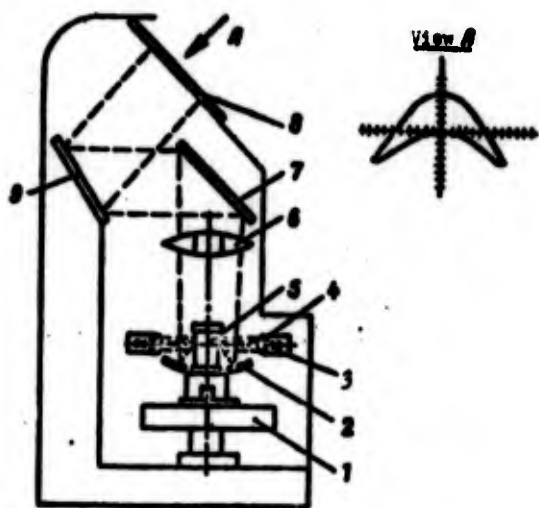

Fig. 14.14. Diagram of a projector for the control of blades: 1 - table; 2 - adjustable mirrors; 3 - light source; 4, 6 - lenses; 5 - blade to be controlled; 7, 9 - mirrors; 8 - screen.

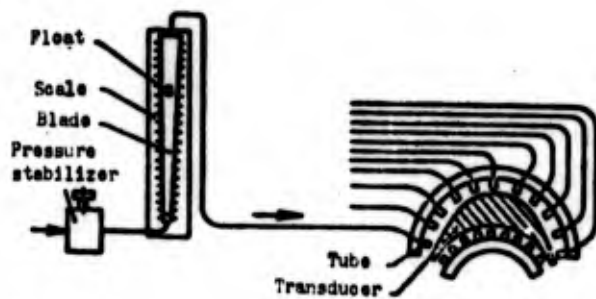

Fig. 14.15. Control of blades by pneumatic transducers.

Consequently, if the controlled blade with deviate from the standard, then this will lead to a change in flow rate of air through the nozzle. Flow rate of air is measured by a rotameter, which consists of a tube with small conicity and a float located in the tube. Air is fed into tube through the stabilizer, which supports the constant air pressure. With an increase in flow rate through the tube the float will rise, and with a decrease in flow rate it will descent. The position of the float is shown by a scale, which is graduated in units of flow rate.

By the same method deviation of the profile of the blade is determined at other points. It is possible to set the rotameters in series and to tune the transducers according to a standard blade in such a way so that all floats are on one level. Then with control of the blade it is easy to observe deviation from the standard simultaneously at all points.

The field of allowance is determined by two lines, drawn in parallel to the line of the face value.

With control by pneumatic transducers the blade does not touch the transducers, and the latter do not wear out. The surface of the blade is not required to be covered with soot, just as with the optical method of control.

CHAPTER 15

TREATMENT OF IMPELLERS

§ 1. Design, Material and Billets of Impellers

Impellers of pumps of a turbopump unit operate at high numbers of revolutions and at high pressures of liquid. Therefore, high requirements with respect to the accuracy of manufacture and quality of material are placed on them. In a turbopump unit impellers of the closed type are usually used. The most characteristic forms of such impellers are shown on Fig. 15.1.

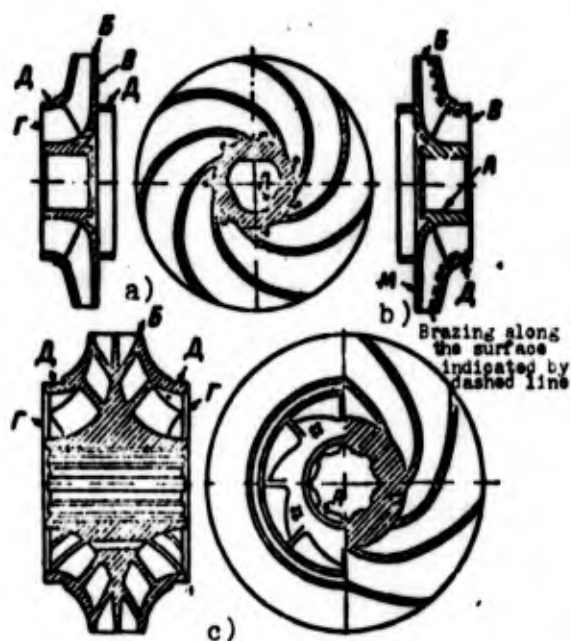

Fig. 15.1. Design of impellers.

Closed impellers are made with unilateral (Fig. 15.1a) and bilateral (Fig. 15.1c) input of liquid. Inside the impellers are guide partitions, which form curvilinear channels for the passage of liquid. The form of the channels is determined by hydraulic calculation. Sometimes for the purpose of easing the treatment of the channels one of the walls is made removable and is connected with impeller by means of brazing (Fig. 15.1b). The hole in the hub has slits for connection with the shaft. The heading slit hole is machined according to the second class of accuracy. On the end of impeller there are annular belts for the labyrinth seal. The allowed play of these belts with respect to the heading hole is 0.02-0.03 mm.

The complex curvilinear form of the channels in closed impellers does not permit treating them by cutting. Therefore, the channels must be obtained with sufficient accuracy and cleanness of the surface in the billet. Billets of such kind can be obtained by casting with the application of rods for the formation of channels.

Materials for the manufacture closed impellers must possess good casting properties. The most frequently used are aluminum casting alloys of the type AL2, AL4, AL5, and AL9, which possess the highest casting properties (small linear shrinkage, increased fluidity, good airtightness). They possess good corrosion resistance and sufficient mechanical strength.

The combined brazed impeller are made from aluminum alloy AV or from steels 1Kh18N9T, 30KhGSA, and others. The billets for them are obtained by the method of hot deformation.

Billets of closed impellers are obtained by chill mold casting, in shell forms or casting by investment patterns.

In the manufacture of impellers by small lots, it is possible to use casting into sand molds. In all cases rods for the formation of channels must be exact and installed on strictly fixed support elements (signs) to ensure assigned accuracy with respect to mutual location

of the channels. The most exact fixing of the rods is attained with casting into permanent metallic forms - chill molds. With casting into shell molds an exact metallic model, which consists of two halves is required. Surfaces of the model must be smooth - they are usually chrome-plated and polished. On the surface of models preliminarily heated to 200-250°C there is applied a mixture of casting sand with a binding substance, for example bakelite (6-8%). Upon the expiration of 1.5-2.5 min a crust of the mixture with a thickness of 10-12 mm will be formed on the surface of the models. These crust-sheets will be separated from the models and dried. In parallel rods for channels and pouring gate system are prepared. Then the assembly of sheets, rods and pouring gate system is produced. The connection is carried out by gluing with special compositions.

Metal is filled into the mold thus prepared.

In the calculation of allowances for machining of the impeller on the ends, periphery and central fitting hole, one should consider not only the thickness of the defective layer, but also the error in the location of the channels, since in the first operation of machining the basing of the impeller should be certainly made on untreated internal surfaces of the channels, which will be discussed subsequently. As practice shows, the allowance for the machining of billets obtained by chill mold casting or shell molds is 2-3 mm to the side. In billets obtained by casting in sand, the allowance attains 7-10 mm to the side.

§ 2. Method of Treatment Closed Impellers

Peculiarities of the machining of closed impellers are determined by the fact that channels inside the impellers are not treated mechanically, and it is impossible to change the position of them in billet. Therefore, it is necessary that positions of all treatable surfaces of the impeller be coordinated with respect to surfaces of the channels not to be treated. Otherwise, a nonuniform thickness of walls and unbalanced state of the impeller will be obtained. Let us explain this in an example.

Figure 15.2 shows the billet of the impeller of nominal external diameter D_{HOM} with allowances for machining. The geometric axis of the impeller is designated I-I. Due to errors in casting allowances can be disposed nonuniformly: on the one side allowance z_1 , and on the other, z_2 . If such a billet is treated being based on the external diameter $D_{\text{гар}}$, then with treatment it will revolve around the axis II-II, displaced from axis I-I by eccentricity $e = \frac{z_2 - z_1}{2}$. With this after boring of the fitting hole, the thickness of the hub will on the one side equal b_1 , and on the other - b_2 . On the side of the smaller allowance (z_1) the thickness of the hub b_1 will be more than that of b_2 .

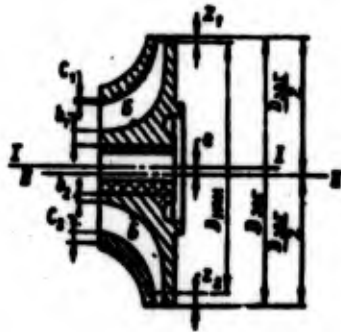

Fig. 15.2. Selection of the method of basing.

In the subsequent operation with machining of the surfaces, the impeller will be set on the fitting hole. Rotation will occur around axis II-II, and after machining the part will be of variable wall thickness, as is shown by the dashed line. The thickness C_1 of the wall on the one hand will be less than the thickness C_2 of the wall on the other hand. Consequently, channels on the one side will be nearer to the axis of the impeller than channels on the other side. This will lead to an irregularity of the distribution of mass of the metal, i.e., to an unbalance, and also will worsen the operation of the impeller. Subsequently it is impossible to change this position since the channels are not machined due to the extraordinary difficulty of the dimensional treatment of closed curvilinear surfaces.

In order to avoid such an error and ensure the uniformity of location of the channels with respect to the fitting hole, it is necessary in the first operation with treatment of the central fitting hole to base the impeller on the internal nonmachineable surfaces of channels, for example, along points 5-5, and, consequently, all channels will be located on the same distance from the axis of the fitting hole. The nonuniform allowance along external surfaces will be removed with machining. The thickness of the hub and thickness of the walls will be more uniform.

The machining of impellers is fulfilled in two stages: rough and finish. With rough treatment the main part of the allowance (up to 70-80%) is taken. Finishing is conducted with less stressed conditions of cutting, the impeller is given the final form, and the cleanness of the surfaces is brought up to that assigned by the drawing. At the end of the second stage balancing of the impeller is conducted, and a protective covering is applied.

Standard Technological Method of Treatment of Closed Impellers

1. Preliminary dressing of the channels.
2. Turning of faces and boring of a hole.
3. Rough machining of external surfaces.
4. Broaching of slits of the fitting hole.
5. Finishing of external surfaces.
6. Turning of labyrinth belts.
7. Drilling of holes and cutting of thread in the hub.
8. Final dressing of the channels.

9. Static balancing.
10. Final control.
11. Galvanic plating.

§ 3. Basic Operations of Treatment

Before the machining of closed impellers the internal channels. Methods of dressing are selected depending upon the state of the surface of the channels after casting. At the inlet and outlet the channels can be cleaned by cutters, metallic brushes and other similar tools. In closed places - in the middle of the impeller - it is impossible to use. Therefore, for dressing other means are needed: blasting by sand, pumping of liquid in the mixture with the abrasive (hydroabrasive dressing). It is necessary to consider that with sand-blast or hydroabrasive dressing, the metal is removed from the surface very intensively on bends of the channels with a change in the direction of the stream. Therefore, in curvilinear channels in some places there will be well-cleaned surfaces and in others - absolutely uncleaned surfaces. With an increase in the duration of the dressing a great removal of metal can appear impermissible. An illustration of such nonuniform dressing is given on Fig. 15.3.



Fig. 15.3. Stripping of curvilinear channels.

A stream of air with sand or liquid with an abrasive hits against the wall and on section A-B changes its direction. As a result of the action of centrifugal forces, on this section there will be an intense removal of metal. At the same time the opposite wall on the section B-Г is practically not protected.

For a more uniform dressing of the whole surface of the channels, it is possible to use reciprocating movement of the hydroabrasive suspension with low speeds of flow or other methods.

Machining of the impeller starts from the cutting of faces and formation of the central fitting hole. The base for the installation, as was noted above, is served by the internal channels. Basing can be carried out at the inlet or outlet unit of the channels, depending upon which of these parts of the channels it is more important to position more exactly with respect to the central fitting hole. Figure 15.4 shows three diagrams of basing of the billet on the internal channels.

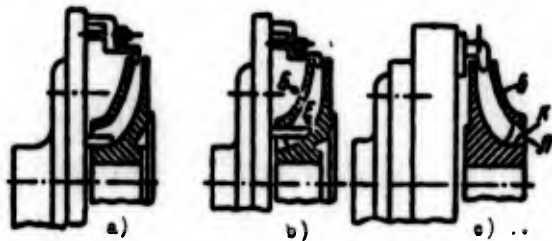

Fig. 15.4. Installations of impellers with basing on the channels.

On diagram a basing is conducted on untreated surfaces of the three channels adjacent to the hub and on diagram b - on the inlet part of the channels adjacent to the front wall B and simultaneously on the second wall of the three channels at points E. In both diagrams the central hole and face surfaces are treated. On diagram c basing is carried out on the outlet part of the three channels. The central hole, face and curvilinear surface B (on the master form) are treated. With this installation leading edges K and Л can also be treated.

In further operations basing of the impeller is produced, mainly, on the fitting hole.

Treatment can be fulfilled both on a lathe and on turret lathes. In final finishing operations basing should be carried out on adjusting elements without clearances in order to avoid errors of treatment. For gapless installation cone mandrels with small conicity or hydroplastic mandrels are used. Treatment should be fulfilled on machines of increased accuracy in order to ensure the assigned accuracy: play of sealing belts with respect to the fitting hole - not more than 0.02-0.03 mm; play of external diameter - not more than 0.04-0.05 mm.

§ 4. Peculiarities of Treatment of Assembly-Brazed Impellers

Assembly-brazed closed impeller is schematically depicted on Fig. 15.5. It consists of casing 1 with blades and cover 2. The casing and cover are treated separately and then are connected by brazing. Such construction permits treating by cutting of the internal cavity of the impeller with high accuracy and good cleanness of the surface. An approximate plan of treatment of soldered impellers is the following [5]:

1. Turning of surfaces of the casing: face, external and holes. The adjusting face and hole for the following operation are turned from one installation.

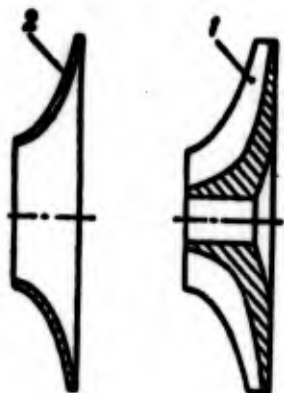

Fig. 15.5. Assembly-brazed impeller.

2. Rough milling of the blades and shelves between them.
3. Finishing (nonfinal) grinding of the hole, faces and external surfaces.
4. Finish milling of blades and shelves between them.
5. Polishing of blades and shelves.
6. Final turning of faces of the hub and blades for brazing (on the master form).
7. Check of the adjoining of the cover (turned on the master form) to the casing of the impeller at places of brazing. With clearances of more than 0.2 mm the cover must be fitted on the casing of the impeller.
8. Superposition and spot tack of lines of the solder to the impeller and assembly with the cover in a special device (sometimes with a clamp at 4-6 points by electric welding).
9. Brazing.
10. Mechanical and chemical purification of the internal cavity from unnecessary solder and carbon.
11. Heat treatment (hardening and aging).
12. Dressing and polishing of channels.
13. Treatment of the hole and face of the casing on the one side and then top and face on the other side.
14. Drilling and counterboring of the holes and cutting of the thread.

15. Broaching of slit fitting hole on the bushing.
16. Final treatment of the casing on the external diameter and labyrinth belts with basing in treatment on the slit hole.
17. Dressing of burrs, sharp edges and washing.
18. Protective covering.
19. Final control.

The machining of casings, covers and impellers after brazing is conducted by the standard methods examined earlier. The blades and shelf between them are milled on duplicating milling machines on a volume master form.

§ 5. Control of Impellers

With final control the geometric dimensions of the impeller, cleanness of surfaces and balanced state of the masses are checked. In the control of the play on sealing belts and external diameter, the impeller is installed by the fitting hole on the mandrel (without clearance) and together with the mandrel is secured in centers of the special device, schematically depicted on Fig. 15.6. The indicator for measurement of the magnitude of the play is secured on a stand, which has a holder adjustable in height.

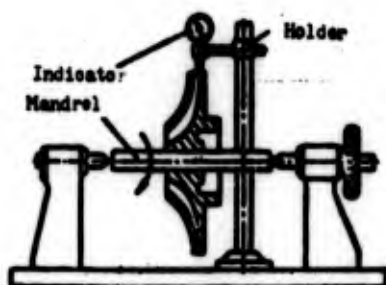

Fig. 15.6. Control of play of surfaces.

To control the thickness of walls various kinds of instruments of the indicator type are used. Figure 15.7 shows an indicator instrument for the measurement of thickness of internal blades. It is based on the principle of shears. Ends of the instrument are bent along the configuration of channels of the impeller checked. For the purpose of maintaining the scale of the measured value, it is necessary that the distance l_1 from the axis of the turn of the levers up to the leg of the indicator be equal to the distance l_2 from the axis of the turn of the levers up to the sylvus-type pins. The instrument is adjusted according to the standard or measuring plates. Static balancing of the impellers is conducted by the same methods as the balancing of disks of turbines (see § 4 of Chapter 13).

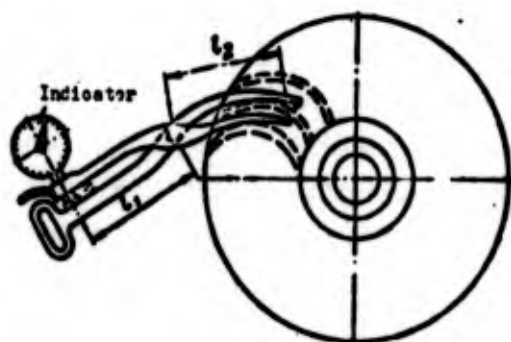

Fig. 15.7. Instrument for controlling the thickness of blades.

CHAPTER 16

TREATMENT OF HOUSING PARTS AND SUBASSEMBLIES OF THE TURBOPUMP UNIT

§ 1. Design, Material, and Billets

Casing parts of turbopump units can be divided into the following basic groups:

1. Casings of pumps.
2. Casings of turbines.
3. Exhaust ducts and collectors.
4. Covers.

The majority of casing parts of a turbopump unit (Fig. 16.1) has a complex form formed by curvilinear, flat and cylindrical surfaces. Curvilinear surfaces, which form volutes, cavities, and recesses, are not subjected to machining but are cleaned for the removal of unevennesses of the surface. Some of such surfaces are designated by the letter H.

For the installation of bearings, packings and other parts adjoining to shafts of turbines and pumps, in the casings, grooves, borings, and seating bosses are made. These fitting places are

machined with high accuracy - according to the 2nd or 1st class. The mutual play of the fitting surfaces is allowed within 0.03-0.05 mm, and nonparallelism of the faces - 0.03-0.08 mm. With the same high accuracy places of joints of casing parts with each other along planes of disassembling Π are machined. Especially stringent requirements are placed on fitting and joint places in designs of the turbopump unit having a common shaft of the turbine and pumps.

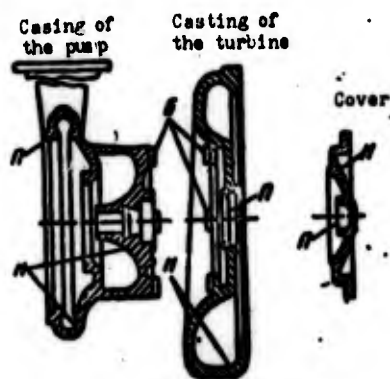

Fig. 16.1. Casing parts of a turbopump unit.

The combination in one part of untreated surfaces having relatively rough allowances with surfaces treated with high accuracy is one of the characteristic peculiarities of casing parts.

The material for the bodies is selected proceeding from conditions of their operation, the minimum weight possible and manufacturability of design. Casings of pumps are made most frequently from aluminum casting alloys of the AL4 type which possess high casting properties with sufficient strength.

It is also preferable to prepare casings of turbines from alloys of the AL4 type if this is allowed according to thermal conditions. At the high temperature of gases casings of turbines are made from heat-resistant stainless steels of the 1Kh18N9T type. Casings of pumps

for the pumping of aggressive liquids are made from titanium alloys possessing high corrosion resistance. Sometimes according to conditions of minimum weight and design considerations, the casing parts are prepared by stamping from a sheet with subsequent welding. For welded stamp casings alloys EI606 and EI654, steel 1Kh18N9T and others are used.

Welded casing from sheet materials, as a rule, are cheaper and lighter than the cast housings, and therefore they find wide application.

Figure 16.2 shows an example of the manufacture of a welded casing of a turbine with an exhaust collector. Casing is divided into three elementary parts. The central part - collector 2, is prepared by stamping from a thin sheet, and flange 1 and fitting ring 3 are obtained by lathe work. The elementary parts are united by two annular welded seams C. Welding is conducted in a special device, and the parts are turned by a welding manipulator.

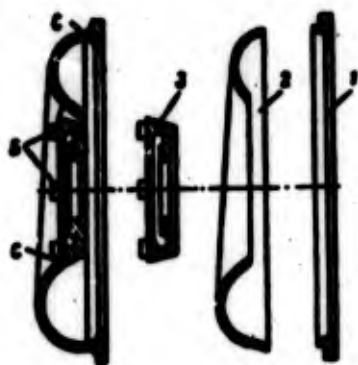

Fig. 16.2. Welded casing of a turbine: 1 - flange; 2 - collector; 3 - ring.

§ 2. Methods of Treatment

The basic peculiarity of treatment of casing parts is condition by the fact that certain surfaces of bodies are not machined and are only cleaned for the removal unevennesses and have relatively rough

dimensions, and other surface of the same casing should be machined with high accuracy. With an unconsidered technological process and unsuccessful selection of base surfaces, part of dimensions of the body cannot be maintained within limits of the allowances, and the parts will be rejected.

The most important stage of development of the technological process of the manufacture of the body parts is the selection of bases for machining. In the first operation for the primary rough bases one should select such surfaces which in the prepared casing remain untreated. In all subsequent operations for technological bases, as a rule, mechanically treated surfaces are taken. Let us explain this in a simple example of the treatment of a cover shown on Fig. 16.3.

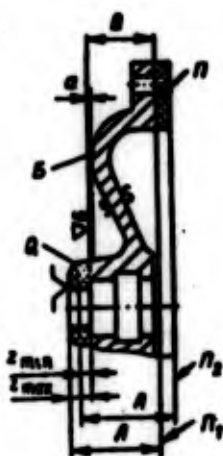

Fig. 16.3. Treatment of the cover.

According to conditions of assembly it is required that the left side of the central boss come forward beyond the plane of the cover by magnitude a . Planes Q and Π , for which allowances z are provided, are subjected to machining. The width of the cover is B .

If in the first operation with treatment of plane Π for the base of the axial position of the part plane Q , having the allowance z is taken, then due to the irregularity of allowance for various parts, treatment will be with indefinite respect to dimension a . With

maximum allowance z_{\max} plane Π of one part after treatment will be at position Π_1 and of the other part at minimum allowance z_{\min} - at position Π_2 (it is assumed that treatment is conducted on a tuned machine and dimension A does not change). In the subsequent operation with treatment of surface Q, for the base in the axial position surface Π will be accepted, and tuning of the machine must be produced on dimension B (width of the part).

With such treatment the end surface Q will be determined by the position of surfaces Π_1 and Π_2 not connected with dimension a. With great deviation (to the right according to the drawing) of surface Π_2 , the dimension a can appear equal to zero. Consequently, basing in the first operation on surface Q (subsequently machined) is impermissible.

For the base in the first operation one should take the other surface, remained untreated in the prepared part, for example, the flange of the cover at points B (along the circumference). Then in the first operation the machine should be tuned to dimension B-a, and plane Π should be treated.. The A in the subsequent operation, with basing on surface Π and tuning to dimension B, will automatically be obtained by the assigned dimension a.

In casing parts many machined surfaces are mutually connected, for their coaxiality rigid allowances are assigned. Therefore, it is desirable to machine such surfaces from one installation of the part with the same technological bases. A change in bases and even another installation on the same base lead to errors of treatment. In order to decrease the number of installations and changes in bases. With treatment of casing parts multitool adjustments are used. Besides the increase in accuracy of treatment, this leads to the lowering of the laboriousness of manufacture of the casings.

In the selection of equipment dimensions and form parts to be treated and also the possibility of the application of multitool adjustments are considered. It is expedient to machine small and

average casing parts on lathes and turret lathes. For the treatment of large-dimension parts vertical lathes and boring machines are used.

Approximate Method of Treatment of a Casing
of a Pump from a Cast Billet [5]
(see Fig. 16.1)

1. Milling of flow gates and filing of bosses.
2. Preliminary metal-working dressing of internal cavities.
3. Dressing of internal cavities by the vibration tumbling hydroabrasive or other method.
4. Marking.
5. Preliminary boring of the central hole and internal grooves on one side.
6. Cutting of faces of connecting bosses 5 of the crosspiece and preliminary boring of holes and centering belts on the other side.
7. Milling of a groove in four connecting bosses 5 of the crosspiece.
8. Milling of faces of flanges.
9. Boring of the throat.
10. Drilling and counterboring of holes in flanges.
11. Cutting of a thread in flanges, metal-working dressing and installation of pins.

12. Hydro- and pneumatic tests.
13. Final treatment of fitting places on one side.
14. Final treatment of the central hole and seating bosses on the side of the crosspiece.
15. Final control.
16. Anodizing.

Approximate Method of Treatment of the Casing
of a Turbine of Welded Construction of the
Type Shown on Fig. 16.2

1. Preliminary treatment of flange 1, flange to the exhaust pipeline and fitting ring 3 (methods of manufacture of flanges and rings were examined in § 2 of Chapter 7).
2. Stamping of the collector 2 (methods of obtaining thin-walled billets are discussed in Chapter 2).
3. Machining of edges of the collector with a special device.
4. Welding of bosses 5 to the fitting ring 3 (bosses can be obtained by milling).
5. Welding of the fitting ring to the collector.
6. Welding of flanges.
7. Dressing of seams and internal surfaces of the collector.
8. Preliminary boring of the central hole and cutting of the end of the bosses.
9. Preliminary treatment of the flanges.

10. Milling of grooves in the connecting bosses.
11. Drilling and counterboring of holes in the flanges.
12. Cutting of a thread in flanges, metal-working dressing and setting of pins.
13. Hydro- and pneumatic test.
14. Final treatment of flanges.
15. Final treatment of the central hole and seating bosses.
16. Final control.
17. Anticorrosive and heat-resistant coatings.

§ 3. Fulfillment of Basic Operations

The dressing of internal mechanically untreated surfaces is to remove unevennesses from these surfaces and to obtain the required cleanness. Depending upon the configuration and state of the surfaces and also on the class of cleanness, some form of dressing is used. Large separate unevennesses depart by the metal-working method.

Sand blasting gives a rough surface and can be used for preliminary purification in accessible places.

Hydroabrasive cleaning consists in the pumping through cavities of the casings of water with suspended particles of abrasive. Grains of the abrasive hit against the surface of the casing and with its motion with respect to the surface will cut small particles of metal. The metal is removed most intensively at places of the change in direction of the flow. Particles of the abrasive in the distorted flow by the action of centrifugal forces are pressed to the external wall H (Fig. 16.4a), where intense removal of the metal occurs. The

internal wall B is cleaned considerably worse. With sharp distortions and high speeds of flow the internal wall remains practically uncleaned, and the external wall can become impermissibly thin. This is the basic deficiency of hydroabrasive dressing of casings.

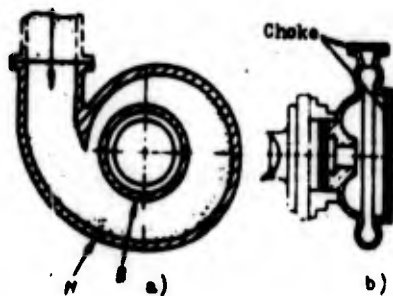

Fig. 16.4. Dressing of internal surfaces of casings.

A more uniform removal of the metal is obtained with hydroabrasive dressing according to diagram b. On all open places chokes are installed, and inside the casing, approximately by $2/3$ or $3/4$ its volume, a liquid with an abrasive is filled. The casing slowly revolves, and the liquid together with the abrasive under the action of gravity moves all the time with respect to walls of the casing, cleaning the surface. Since the rotation slow, centrifugal forces are very small, and, consequently, dressing goes evenly. The basic deficiency of this method is the low productivity. To increase the productivity, inside the casing together with the abrasive a certain quantity of large casings, for example, steel, cast-iron or porcelain balls are cleaned. These casings, with rolling and slipping over the surface, press to the surface certain grains of the abrasive and accelerate removal of the metal. Even greater effectiveness is given by the anodic and abrasive method, which uses an electrolyte as the liquid, through which direct current is passed. In such a way a cleanliness of the surface of a casing of complex configuration $\nabla 6$ can be obtained after 4-6 hours of continuous treatment.

Vibration tumbling. With this method inside the casing there are abrasive balls (for example, porcelain), and vibration motion in three mutually perpendicular planes is imparted to the casing. Under the action of the balls travelling with respect to the surface of the casing, intense dressing of the surface occurs.

Machining of small-dimensional casing parts is conducted on turret lathes or on lathes equipped with special holders for cutters, turning support heads and other devices. With treatment multitool adjustments are used, so that from one installation as large a number of surfaces of part as possible can be treated. For reliable fastening of the casing to be treated special devices are used. In the selection of fastening places one should consider the rigidity of construction of the casing. Forces of the clamp must not deform the casing. This is especially important in the fastening of thin-walled casing parts, for example, exhaust collectors possessing small rigidity.

Large-dimensional casing parts are treated on vertical turret lathes of models 152, 153, 1531 (single-frame), 1551 (double-frame) and others depending upon dimensions of the casing. Upper supports of these vertical turret lathes have a five-position turret head, which allows conducting a multitool adjustment. Furthermore, part of the cutters is disposed on the horizontal (lateral) support.

Machining of casing parts is fulfilled in two stages: preliminary, on which the main part of allowance is removed, and the final. Such a division is conditioned by the fact that after machining casings are somewhat deformed due to the redistribution of the internal stresses in the material. This is especially noticeable in the treatment of thin-walled casings. The warping of flanges, oval shape of fitting holes and bosses and other deformations appear. The magnitudes of these deformations can be larger than those allowed. With treatment in two stages after preliminary treatment (removal of the main part of the allowance), the casing is deformed and takes the final form. In the second stage all earlier obtained errors are corrected, and a small layer of the metal, which affects little the equilibrium of internal stresses, is removed.

After final treatment the shape of the casing remains practically the same as was given to it by preliminary machining. It is necessary to consider that the process of redistribution of internal stresses in the material of the casing after preliminary machining goes through a certain time, called the period of aging. This period in natural conditions occupies several tens of days. Artificial aging, with increased temperature, continues from 3 to 20 hours. If the finally treated casing parts in the course of time lose their exact dimensions, then into the technological process of treatment one should introduce the operation of aging, conducted after preliminary machining.

Hydro- and pneumatic tests of casing parts are conducted before final machining. This is dictated by the fact that during hydrotests of strength pressure higher than the rated is given. As a result of this in the material of the casing great stresses and, consequently, great deformations appear. In certain places of the casing stresses can exceed the yield point of the material, i.e., irreversible (residual) deformations will appear. After such hydrotests the geometric form of the part changes - warping, stretching and other defects appear, disturbing the initial form. These defects are corrected with subsequent final machining.

Casing parts of a turbopump unit operate at different operating pressures. According to these pressures, the designer selects thicknesses of the walls. For example, the casing of a pump has two cavities: cavity of low inlet pressure into the pump (with relatively thin walls) and cavity of high pressure - at the outlet. A test of these cavities should be conducted separately - each cavity is tested under a corresponding pressure, although these cavities are connected. This is the difficulty of hydrotests.

Figure 16.5 gives a diagram of hydrotests of the casing of a pump. At appropriate places of the casing chokes are installed, and the internal cavities are filled with water. In this case there should not be cavities (air cushions) filled with water according to conditions

of safety engineering. Cavity A of low pressure and cavity B of high pressure are tested at different pressures. Therefore, between these cavities in section C an internal choke should be set. Water is fed into every cavity along a separate line through stop valves and reduction valves. On every line there must be installed a safety valve tuned to a pressure somewhat exceeding the pressure of the hydrotests. Pressures of the hydrotests are controlled by manometers.

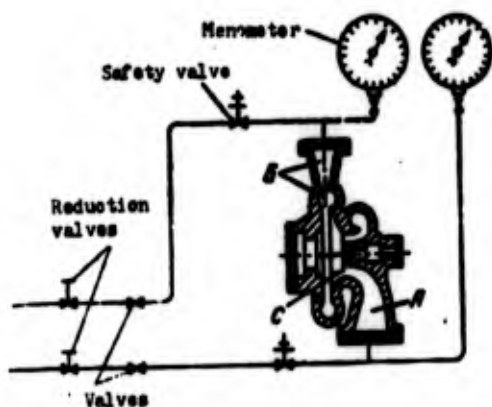

Fig. 16.5. Diagram of a hydrotest of a pump casing.

Destruction of casing parts during hydrotests under low pressure occurs gradually: into the crack formed part of the water flows, and the pressure rapidly drops. Such tests are absolutely safe. Destruction at pressures of 100-1000 atmospheres and above has a different character. At such pressures the compressibility of the liquid can no longer be disregarded - its volume noticeably decreases. Furthermore, under the action of great internal forces the internal volume of casing to be tested is increased due to elastic extension of the walls. Consequently, the casing found under great internal liquid pressure accumulates great potential energy. With the appearance at some place of a crack the casing rapidly loses strength and is instantly destroyed. The accumulated potential energy turns into kinetic energy, scattering fragments of the casing at high speed. Such destruction is similar to an explosion and is dangerous for

maintenance personnel. Therefore, hydrotests under high pressure are conducted in special armored cabins with remote observation of the behavior of the test casing on measuring instruments mounted on a panel outside the cabin.

Pneumatic tests by compressed air or gas are even more dangerous. Therefore, they are also conducted in armored cabins. To reveal nonhermeticity the test casing is placed in a bath with water. For the best scanning the casing is turned by a special manipulator. With tests by air small nonhermeticities are not revealed, and therefore for the test an air-freon mixture or helium are used. The detection of places of nonhermeticity is produced by special leak detectors.

§ 4. Control of Body Parts

The whole technological cycle of the manufacture of casing parts is accompanied by thorough technical control. Methods of control of the quality of the material of billets and quality of welded seams were discussed earlier. It is recommended to conduct the operation control of geometric dimensions directly on the machine, not removing the secured part. The indicator instrument, set on a mandrel, is aligned on one of the seating bosses or hole, then the play of other surfaces with respect to the base is checked. To check the play of the planes, the indicator instrument is set in the fixed mandrel of the support of the machine, and the part is slowly turned. For final control of prepared parts taken from the machine special measuring instruments, brackets and patterns are used.

With exact measurements of large dimensions one should consider the change in dimensions due to the thermal expansion of metals under the effect of temperature. With small dimensions the linear thermal expansion can be disregarded. Measuring tools in the form of steel rods with an increase in temperature of 10°C are extended 0.012 mm for each meter of length (nominal value of scales is given at a temperature of $18-20^{\circ}\text{C}$). Parts from aluminum and its alloys with an increase in temperature of 10°C are extended 0.024 mm for each meter

of length. For the purpose of decreasing errors in measurements under the effect of thermal factors, it is desirable to maintain a constant temperature in the workshop or in the control room. When it is impossible to maintain a constant temperature, standards for the tuning or measuring instruments are used.

P A R T I V

MANUFACTURE OF PARTS OF AUTOMATIC EQUIPMENT

CHAPTER 17

MANUFACTURE OF PARTS OF AUTOMATIC EQUIPMENT

The system of automatic control of a rocket engine includes different kinds of valves - cutoff, stop, control, pressure reducers, regulators and other units. In spite of the great variety of units of automatic equipment, their parts with respect to technological criteria (similarity of processes of treatment) can be divided into several groups.

The most widespread groups of parts of automatic equipment are the following:

1. Casing parts.
2. Rods, pushers, axels and shafts.
3. Valves, plates.
4. Springs.
5. Membranes.
6. Packings.

Let us examine basic peculiarities of the technological process of the manufacture of these groups of parts.

§ 1. Manufacture of Casing Parts of Automatic Equipment

Casing parts of automatic equipment are prepared from aluminum alloys, stainless steels, and also from standard carbon steels with subsequent protective covering. External surfaces of the parts

have comparatively rough dimensions – according to the 5th or 7th classes of accuracy – and can be formed by casting or stamping. Internal surfaces are made more exactly and almost always are machined.

Figure 17.1 shows two variants of parts of this group (a and b). Blanks for such kind of parts are obtained by casting or stamping.

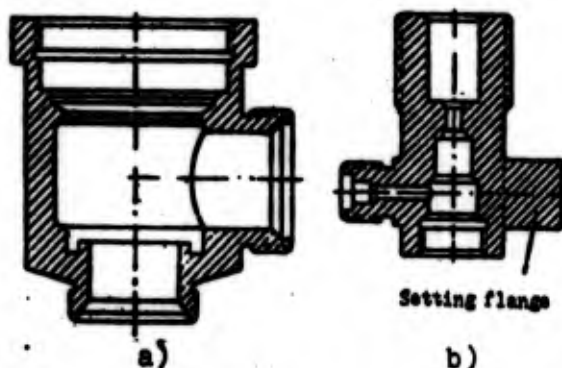

Fig. 17.1. Casings of valves.

Only in exceptional cases, in experimental production, when dimensions of the group parts are small, rolled products are selected as the blank (if this is allowed according to the TU on the casing). The economic expediency of a certain form of the blank is determined by comparative economic calculations taking into account the form of production, dimension of the group, available equipment and other factors. The method of such calculations has been discussed during the study of subject "Economics, Organization and Planning of Industrial Enterprises." For preliminary tentative calculations it is possible to use an average cost of the blanks taking into account their subsequent machining.

Tables 17.1 and 17.2 give the average relative cost of certain materials and blanks. Accepted as the unit is the cost of profiled round rolled stock from carbon steel. According to price list values it is 6-8 kopecks for one kilogram.

Table 17.1 Average relative cost of materials.

Assortment	Material	Relative cost
Circle, square, strip, thick sheet	Carbon steels of ordinary quality: St. 1, St. 2, St. 3 St. 4, St. 5	1
The same	Carbon Machine-building steels 10, 15, 20, 25, 30, 35, 40, 45, 50	1.2-1.3
" " "	Low-alloy steels of the type 45G, 50G, 20Kh, 40Kh, 50Kh	1.5-1.8
" " "	Steels of the type 30KhGSA	2-2.5
" " "	Stainless steels of the type 1Kh18N9T	7-10
" " "	Aluminum alloys	5-8
Duralumin in sheets	D1, D1A, D16	6-12
Sheets, rods	Copper M1, M2, M3	10-15
Red	Bronze BrAZh9-4	12-18
"	Nickel	40
Shaving of ferrous metals		0.1
Shaving of aluminum alloys		2
Shaving of copper and copper alloys		4-5

From Table 17.2 it is clear that 1 kg of castings and forgings is several times more expensive than 1 kg of rolled stock.

Let us consider the example of preliminary calculation of the economy of manufacturing blanks.

Example. Determine economically the rational form of the blank of the casing of the valve depicted on Fig. 17.1b. The material of the body is an aluminum alloy. Production is of small lots. Fig. 17.2 shows two combined forms of the blank: one (shown by solid lines) is obtained by stamping; the second (shown by dashed line) constitutes a segment of rolled strip with section 60 × 40.

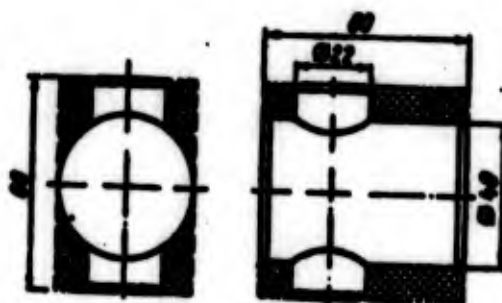

Fig. 17.2. Blanks of the casing of a valve.

Table 17.2. Average relative cost of castings and forgings of average complexity from carbon steel.

Method of obtaining the blank	Kind of production	Relative cost (with respect to the cost of round rolled steel)	
		Small blanks with a weight up to 3 kg	Average blanks with a weight of 3 to 10 kg
Casting into shell for forms	Mass (groups of more than 700 pieces)	3-4	2.5-3.5
The same	Small-let (groups of 400-700 pieces)	5-6	4-5
Casting in chill mold	Mass	3-4	-
The same	Small-let	5-7	-
Casting in investment patterns	Small-let	7-12	-
Stamping on crankshaft presses and hammers	Mass	3-4	2.5-3.5
The same	Small-let	4-6	3-4
Stamping on horizontal-forging machines	Mass	3-4	-

Let us determine what form of the blank is economically more profitable in small-lot production. For calculations let us take the cost of the basic unit (i.e., cost of the rolled stock from carbon steel of an ordinary quality) at 80 rubles for a ton or 8 kopecks for one kilogram. Cost of one kilogram of rolled stock from an aluminum alloy is $8 \cdot 6 = 48$ kopecks. Cost of one kilogram of forgings from an aluminum alloy with small-lot production is $8(6 + 5) = 88$ kopecks. Cost of a kilogram of shaving from an aluminum alloy is $2 \cdot 6 = 12$ kopecks. All calculations are given in the following table:

Elements of the calculation	Variant 1 Stamped blank	Variant 2 Blank from rolled stock
Volume of the blank in cm ³	$\frac{\pi \cdot 4^2}{4} \cdot 6 + 2 \cdot \frac{\pi \cdot 2,2^2}{4} \cdot 1 = 80$	$4 \cdot 6 \cdot 6 = 144$
Weight of the blank in kg	$0,08 \cdot 2,75 = 0,22$	$0,144 \cdot 2,75 = 0,4$
Weight of the wastes in kg	—	0,18
Cost of wastes in kopecks	—	$0,18 \cdot 12 = 2,2$
Cost of blank in kopecks	$0,22 \cdot 88 = 19,4$	$0,4 \cdot 48 = 19,2$
Cost of the blank taking into account the realization of wastes (shaving) in kopecks	19,4	$19,2 - 2,2 = 17,0$

From the given data it is clear that the cost of the blank from rolled stock is 2.4 kopecks less. But it is necessary to consider expenditures for excess machining of the blank from rolled stock. The excess removed layer of metal on Fig. 17.2 is shaded by crossed lines. In the treatment of the housing it is necessary to remove from each side a layer of metal ~ 15 mm. Let us take the speed of rotation of the spindle of the machine (turret-lathe) at $n = 600$ r/min, depth of curving $t = 2.5$ mm, feed $s = 0.3$ mm/rev, and number of passages $z = 6$. Then the machine time for treatment

$$t_m = \frac{(l_1 + l_2) z}{ns} = \frac{(30 + 1) \cdot 6}{600 \cdot 0,3} = 1,1 \text{ min,}$$

where l_1 - length section to be machined; l_2 - length of incision.

The auxiliary time on installation, returns of the tool and other motions

$$t_n = 0.16 + 6 \cdot 0.08 = 0.64 \text{ min.}$$

The piece time

$$t_{\text{шт}} = (t_n + t_2)K = (1.1 + 0.64) \cdot 1.07 = 1.9 \text{ min.,}$$

where K - coefficient considering the loss of time for service.

The time for treatment of lateral pipe connections will be somewhat less. Let us take the time for treatment of a pipe connection at $t_{\text{шт}} = 1.5$ minutes. The total time for treatment of the blank

$$t_0 = 1.9 + 1.5 \cdot 2 = 4.9 \text{ min.}$$

Tariff rate of worker of piece worker of the third class is 41.3 kopecks per hour. Basic wage for one procurement

$$3 = \frac{41.3 \cdot 4.9}{60} = 3.4 \text{ kopecks.}$$

Expenditures for the operation and depreciation of the turret lathe are accepted at 0.13 kopecks per minute.

Expenditures for one blank

$$3 = 0.13 \cdot 4.9 = 0.64 \text{ kopecks.}$$

The total expenditure for treatment of the blank

$$C = 3 + 3 = 3.4 + 0.64 = 4 \text{ kopecks.}$$

The cost of the blank from rolled stock taking into account the expenditure for its preliminary treatment

$$C_{mr} = 17 + 4 = 21 \text{ kopecks.}$$

Thus, the blank from rolled stock was 1.6 kopecks more expensive than the stamped blank.

With mass production the group of blanks is increased, and economic benefits from the application of stamped blanks will be considerably more.

The machining of casing parts of automatic equipment is conducted on lathes or turret lathes.

In the development of the technological process of the machining of casings, one should strive for a maximum decrease in the number of installations of the part, since every installation introduces an error of basing. This especially pertains to the treatment of internal surfaces, which determine the direction of motion of the valves and seats on which the valves rest by their packing surfaces. A good fitting of the valve on the seat can only be when the plane of the seat is perpendicular to the cylindrical surface, which determines the direction of movement of the valve in the casing. The allowed perpendicularity of the seat usually does not exceed 0.03-0.05 mm. This condition is reliably ensured if treatment of the cylindrical surface and seat is conducted in one operation without transposition of the part.

Figure 17.3 shows the position of the casing of a stop valve on the machine with treatment of the basic housing. Basing is fulfilled on surfaces 6 and 10. Face 2, surfaces 4, 7, 8, and 9, faces 1 and 3, and groove 5, are machined and an external thread are cut. Then final boring of the surface 8 is fulfilled and the seat by cutter having a recess along the profile of the seat is formed. In this way the necessary accuracy of the relative position of the axis of hole 8 and plane of the seat is attained.

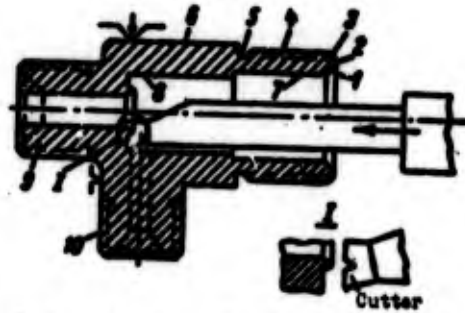

Fig. 17.3. Treatment of the internal cavity of the casing and formation of the seat: 1-10 - surfaces to be treated.

With treatment of the lateral pipe connection the special setting flange or treated surface of the basic housing are based. The setting flange, shown on Fig. 17.1, after treatment of the lateral pipe connection, is cut, and the place of the cut is cleaned.

The presence of a setting flange simplifies the process of treatment; however, the blank is obtained complex and heavy. Treatment of the lateral pipe connection without a setting flange is conducted in a special device. Fig. 17.4 shows one of such devices. The casing to be treated is set on the basing pin 11 and is oriented by stops 10 by the angle of turn. The casing is secured by pneumatic drive, which acts through the rod 3. With movement of rod 3 to the left (as was shown on figure), bushing 2 turns the large arm of lever 5, and its second arm moves slider 6 together with clamp 8. For convenience of installation of the casing, clamp 8 can turn on axel 7.

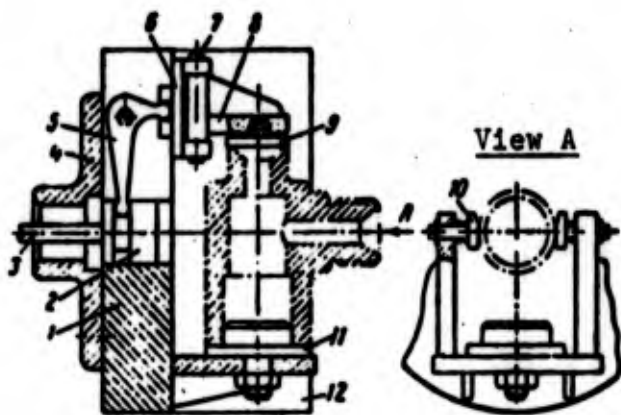

Fig. 17.4. Device for the treatment of the lateral pipe connection: 1 - body; 2 - bushing; 3 - rod; 4 - face plate; 5 - lever; 6 - slider; 7 - axis; 8 - clamp; 9 - head; 10 - lateral stop; 11 - basing pin; 12 - barrier.

§ 2. Manufacture of Rods, Pushers, Valves

The treatment of rods, pushers, axles, shafts and other similar parts is conducted on lathes, turret lathes or automatic lathes. For all these parts drops in diameters of the steps are usually small, and therefore the blanks for them are profiled rolled stock of different diameter. The rolled stock is preliminarily guided and cut on measuring blanks for one or several parts.

In the machining of external surfaces it is expedient to use hydroduplicators. Rods and other long parts have low rigidity and with treatment sag, which leads to the distortion of their form (conicity, barrel-shapedness). To decrease the sag, a support with a fixed center and the installation of lunettes are used.

Plates and valves are made both one-piece and reinforced by sealing elements. Figure 17.5 shows three characteristic forms of valves: a) plate, having an annular sealing edge H; b) cone-shaped surface K of hyperbolic or parabolic form; c) cylindrical with a sealing element made of rubber, kapron, teflon or another material. In mass production blanks for valves of form a and b are forgings and for valves c - round rolled stock.

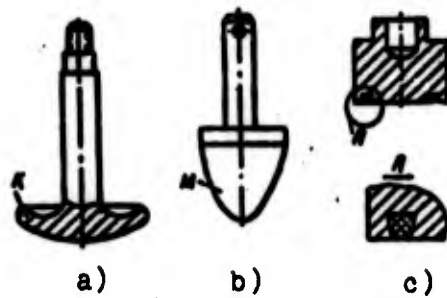

Fig. 17.5. Forms of valves.

Machining is fulfilled on lathes and turret lathes. The sealing element is secured by glue, vulcanization or rolling in of the edges.

§ 3. Manufacture of Springs

Springs in many units of automatic equipment are very important parts. By possessing elasticity, they can store energy and preserve it for a long time. At the needed moment this energy is liberated and is used for operation of the valves or other purposes.

In units of automatic equipment mainly spiral cylindrical springs of compression are used.

For the manufacture of springs carbon and alloyed steels are used and less often – alloys from nonferrous metals.

Material of springs should possess considerable strength, elastic properties stable in time, and the ability to allow great plastic deformations in the manufacture of springs.

With the acceptance of spring wire special attention is given to the state of the surface: cleanness of finishing, the absence of pits, seams laps and other defects. The macrostructure of the steel should be without shrinkage friability, and without vacuums, cracks, bubbles and slag inclusions. A check is conducted according to GOST or special standards.

For springs of brands 65, 70, 65G, 55GS, 50KhGA, 60S2KhA and others are used.

For the manufacture of spiral springs cold-drawn patented or hard-drawn wire is used.

Patented (piano) wire in the last stage of manufacture is passed through a furnace and heated to 150-200°C higher than the temperature of hardening, after which it is put into melted lead (patenting operation).

In this case there occurs a change in the structure of the steel, which is accompanied by a growth in the grain. With the last final drawing, the wire is greatly workhardened.

In the manufacture of hard-drawn wire the operation of patenting is replaced by tempering at a temperature of 600-680°C. With final drawing the wire is subjected somewhat lesser work hardening, in consequence of which its plasticity is somewhat more than that of piano wire.

The technological process of the manufacture of springs consists in the following basic stages:

1. Coiling of the springs.
2. Finishing of faces.
3. Heat treatment.
4. Technological test and compression.

The coiling of springs is done in a cold or heated state on special mandrels secured in the holder of the machine. In mass production coiling is fulfilled on automatic machines.

A diagram of the coiling on a mandrel is shown on Fig. 17.6. The end of the wire is preliminarily secured in a clamp, and tension is created. With rotation of the mandrel the wire is gradually extruded from the tension device and wound on the mandrel. The pitch of the coiling is determined by the magnitude of feed of the support.

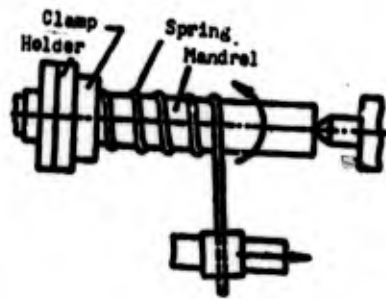

Fig. 17.6. Diagram of coiling of a spring on a mandrel.

Springs from wire with a diameter up to 10 mm are wound in a cold state from preliminarily completely prepared material. The diameter of the mandrel should be somewhat less than the internal diameter of the spring, since due to the elasticity of the material, after removal from the mandrel, dimensions of the spring are increased. The degree of the decrease in diameter of the mandrel is set by experimental means.

By the cold method on mandrels springs are also wound from annealed soft wire, which are then subjected to hardening and tempering.

Powerful springs from thick wire or thick rods are wound on mandrels in a heated state with subsequent heat treatment (hardening and tempering).

The finishing of faces of springs of compression is fulfilled in such a manner so that the initial support turns (on both sides) are folded to one another almost up to the contact of the turns at a length from 0.75 to 1 turn, as is shown on Fig. 17.7. After compression the support turns are turned, and then they are ground to ensure the perpendicularity of faces of the axis of the spring.

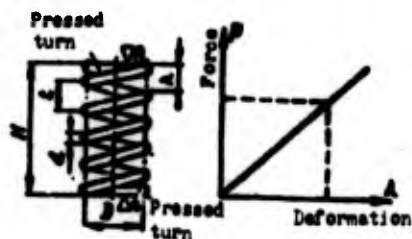

Fig. 17.7. Diagram of the treatment of faces of a spring and characteristic of the spring.

Heat treatment is conducted on all springs after coiling and preliminary finishing of the faces. Springs wound by the cold method from preliminarily prepared material are subjected only to tempering in oil or salt baths at a temperature of 230-315°C for 15-30 minutes depending upon dimensions of the spring. Springs wound from an annealed material or by the hot method are subjected to preliminary (normalization or tempering) and final (hardening with subsequent tempering) heat treatment. Conditions of heat treatment are set depending upon the brand of steel.

A technological test of the spring is conducted after completion of the whole process of its manufacture and control of dimensions and state of the surface. The tests consist of double or triple compression of the spring up to the contact of the turns. After the test the length of the spring should remain constant. The allowed deviations are regulated by standards or specifications (TU).

Compression of the spring is to increase its supporting capacity. The process of compression consists in the fact that the spring is compressed up to the contact of the turns and is held in such a state for 6-48 hours, depending upon the assignment of the spring.

With compression stresses in the spring exceed the elastic limit of the material, which leads to plastic deformations in external layers of the turns.

With unloading of the compressed spring the elastic-deformed core of the turns tries to return to the initial position, but this is prevented by the plastically deformed external layers of the turns. As a result of such interaction, in the core of the turns the stresses which appear with compression are partially preserved, and in the surface layer stresses of the reverse sign appear. Residual internal stresses increase the load ability of the spring.

P A R T V

ASSEMBLY OF ROCKET ENGINES AND THEIR SUBASSEMBLY

CHAPTER 18

DEVELOPMENT OF TECHNOLOGICAL PROCESSES OF ASSEMBLY

§ 1. Basic Determinations and Flow Diagram of Assembly

Assembly is the completing stage of production. As a result of assembly separate parts are connected into subassemblies, groups, units and, finally, into articles manufactured by the plant.

The part is called the part of an article which is made without assembly operations. Parts can be simple (bolt, nut, washer, pin, key) or complex (shaft of a turbopump unit, turbine disk, casing of a pump).

A unit is called the completed assembly unit consisting of two and more parts united with each other. Connections of parts in the subassembly can be both nondetachable (welding, soldering, gluing, pressing) and split (thread, key, slit). For convenience of assembly complex subassemblies can be divided into separate subassemblies.

A subassembly consists of several parts united with each other making up to the unit. With construction of the technological process of assembly, it is expedient to divide units of an article into groups and subgroups.

The group is a unit or several units united with each other which, directly enter into the assembly of the article.

The subgroup is a unit or several units united with each other which enter into the assembly of the article in the composition of the group.

Assembly is divided into general and unit.

General assembly is the assembly of the completed article of the given plant. Sometimes this concept is conditionally extended to the assembly of completed adjacent groups, for example, general assembly of the turbopump unit.

Unit assembly is the assembly of subgroups and groups making up the article.

The technological process of assembly is the rational sequence of actions for the connection of parts into units groups and articles corresponding to requirements of drawings and technical conditions on the given article. The technological process of assembly can be divided into separate operations.

The operation of the assembly is the part of the technological process of assembly fulfilled at one definite work station by one worker or one team of workers. The operation is divided into transitions.

A transition is the part of the operation fulfilled over one definite connection with a permanent tool or permanent equipment.

Example. Install a cover on the casing of a pump - operation consisting of five transitions:

1. Put a spacer on the casing, levelling it along the internal contour of the hole.
2. Install the cover.

3. Insert bolts into holes and turn them with the assigned moment of tightening.
4. Lock nuts with wire.
5. Seal.

For the purpose of simplification of the development of the technological process of the assembly and also an appraisal of the design from a technological point of view flow diagrams of assembly are constructed both for the assembly of units and groups and for the general assembly of the article. These diagrams show the sequence of assembly and the possibility of separations of the entire assembly into unit assembly.

Each element of the article on the diagram is conditionally designated by a rectangle divided into three parts (Fig. 18.1). In the upper part designation of the element is indicated, in the left lower part - index of the element, in the right lower part - quantity of elements proceeding for one assembly. The index of the element should correspond to the index or number of drawing of the part or unit.

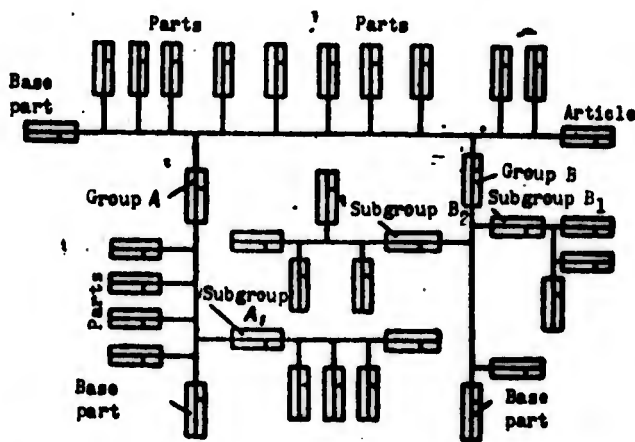

Fig. 18.1. Flow diagram of assembly.

The base is the basic element (part or unit), from which the assembly starts. If the content of the operations is vaguely directly from the diagram of assembly, then on flow diagrams there

are made additional explaining inscriptions, for example: solder, check the coaxiality and others.

As an example in Fig. 18.1 shows a flow diagram of the assembly of an article of average complexity.

§ 2. Methods of Assembly

The following methods of assembly are used.

Method of full interchangeability. With this method all parts and units are assembled without any machining, fitting or replacement of some parts by others. This method of assembly is the simplest and requires the minimum labor input and time for assembly of a unit or article.

The application of the method of full interchangeability is possible with efficiency production high and fulfillment of parts with rigid tolerances for their geometric dimensions. To ensure these conditions a large quantity of technological equipment – special devices, cutting and measuring tools is required. The method of full interchangeability is used, mainly, in mass production. In lot and small-lot productions this method can appear unprofitable, since the lowering of expenditures for assembly cannot justify the expenditures for expensive technological equipment.

Method of incomplete (limited) interchangeability. With this method for the purpose of facilitating the manufacture of parts, allowances for their dimensions are somewhat increased. With the assembly of parts with increased tolerances, a certain part of the collected units or articles will not satisfy the TU and will require reassembly.

Practice shows that in the rational selection of expanded allowances, the percent of unconditional units is small. Expenditures for the reassembly of these units are considerably less than the economic effect from the lowering of the cost of parts with expanded

der,
assembly
tolerances. It is necessary to note, however, that the increase in allowances can be used carefully after appropriate calculations. An unfounded increase in allowances can lead to a mass reject of the assembly.

parts
placement
lest
a unit
is
parts
ure
- special
of
In
able,
y the
this
ts,
the
f the
require
d
enditures
the
xpanded

The method of group interchangeability. This method is called also the trial-and-error method or method of selective assembly. It is used in those cases when according to conditions of the assembly dimensions of the parts must be very exact, and on existing equipment it is difficult or even impossible to obtain them. It is economically inexpedient to install special precision equipment. Then one proceeds in this way: the parts are prepared with expanded tolerances, and then they are collected into groups with respect to the magnitude of the allowance. Classification is conducted with the help of step gauges and brackets, which allow dividing the field of allowances into a number of groups. With assembly only parts of corresponding groups are connected to each other: female parts of 1st group are connected with male parts of 1st group, etc. This method is frequently used with screwing of pins into casings under the condition of a guaranteed force fit.

A deficiency of the group method of assembly is that a large quantity of prepared parts is necessary. With a small reserve it can appear that there are, for example, pins of 1st group, and holes in casings are made according to 2nd group, and, consequently, the assembly is impossible.

Method of the fitting of parts in place is used in those cases when the required accuracy of assembly cannot be attained with technological expedient tolerances for dimensions of parts entering into the assembly. In this case the parts, are prepared with tolerances acceptable for production and the required accuracy of assembly is attained by a change in the dimension of the locking link, called a compensator.

The compensators can be spacers, washers, bushings, rings and other similar parts. The fitting of these parts are carried out by filing, deburring, rubbing, scraping, polishing and other methods.

The method of fitting is laborious and requires high qualification of the workers. It is used, mainly, in small-lot and individual production and also in repair.

The method of adjustment in its basis is the same as the method of fitting, with the only difference being that the required accuracy of the assembly is attained not by fitting, but due to a shift in one of the links, called by the mobile compensator. This can be a nut, wedge, slanting washer, etc.

§ 3. Organization of Assembly Works

Organizational forms of assembly works are selected depending upon the dimensions and weight of articles and units scale of the production, the place and volume of fitting works and other factors.

The technological process of the assembly of a unit or article can be carried out both without separation into separate stages - operations, and with operational separation.

Assembly without separation into operations is used with small-lot or individual production usually with a fixed unit or article and is fulfilled by one team. The duration of the cycle of assembly T_u is equal to

$$T_u = \frac{T}{B},$$

where T - labor intensity of assembly; B - number of workers in the assembly team; it is determined by such an arrangement of workers at which they can work simultaneously, not hindering each other.

For the purpose of expansion of the front of the assembly works and reduction of the cycle of assembly, a parallel assembly of units by special assembly teams is recommended. The general assembly is fulfilled by a separate team. The application of unit assembly, besides reduction of the cycle, lowers the labor intensity and cost of assembly works due to specialization of the workers.

Assembly with separation of the process into operations is used in lot and mass productions. It can be carried out both with a fixed unit or article and with movement of them along the technological of assembly flow. In assembly with separation into separate operations, high specialization of the workers is attained, and the application of specialized technological equipment becomes expedient.

An assembly separated into operations with a fixed object is used in the assembly of heavy or bulky articles, when movement of the article in the process of assembly is inexpedient. The articles are gathered on fixed stands. Each worker or each team of workers fulfills the same operation, passing from one stand to the other.

Continuous assembly with movement of the collected article or unit is conducted by specialized teams, which have stationary work stations equipped with the necessary technological equipment. Movement of the collected object from one work station to the other is carried out by different methods depending upon the weight and dimensions of the object, cycle of the assembly process and other factors. The following methods of movement are used.

1. Transfer of the collected object from one working post to the other manually. It is used in small-lot and lot production of small units and articles, for example, with the assembly of elements of automatic equipment of automatic equipment of liquid propellant rocket engines (valves, reduction valves).

2. Movement of the collected object manually on special assembly-transport carts, which move by railless or rail means. It is used in the case when the weight of the collected object together with the cart is comparatively small, and movement does not present great difficulty and does not occupy much time.

3. Movement of the collected object from one work station to other with the help of special transporting devices of periodic action - conveyers. Assembly is conducted with a fixed conveyer. After a defined time, called the cycle of the assembly, the conveyer moves, transferring all objects on the conveyer from one work station to another.

4. Movement of the collected article on a continuously moving conveyer. The speed of the conveyer is selected so that during the time the article is near work station, it is possible to carry out the assigned assembly operation.

The basic rated value with continuous assembly is the working rate or cycle of the assembly. Separation of the process of assembly into operations should be conducted taking into account the uniform stocking of all workers in the assigned rate of movement of the collected article along the flow. The cycle of the assembly is determined by the formula

$$\tau = \frac{\phi}{N} \eta$$

where ϕ - fund of operating time (daily, monthly, etc.), in min;
 N - number of articles manufactured during the time ϕ ; η - coefficient considering the loss of time due to interruptions, service, etc.

§ 4. Basic Stages of Development of the Technological Process

Assembly works are a very important concluding stage of the whole technological process of manufacture of an article. In the process of assembly the quality of earlier made parts and units is checked. The quality of the assembly of the article in many

respects is governed by its quality, reliability in operation and unflinchingness of operation. Therefore, assembly works at any machine-building plant is given paramount attention.

Of special importance is the assembly of such complex and important objects as liquid propellant rocket engines. The least carelessness, disturbance of the technological process, and insufficient cleanness of the work stations can lead to serious disturbances of operation or nonoperation of the rocket engine. Therefore, the technological process of assembly of a rocket engine and control for its fulfillment are developed so thoroughly and in detail that absolutely all the manufactured "commodity" engines are reliably started operation normally in assigned conditions and with calculated duration. Such absolute reliability is provided special organizational and technological measures developed in reference to a concrete design of the engine.

The limited volume of this book does not permit us to examine all these details of the technology of assembly of rocket engines. Holding to an affirmed program, we will examine only basic principles of the development of the technological process of assembly.

The process of development of the technological process of assembly consists in the following basic stages.

1. Division of the article into unit and groups and determination of the most rational places of their attachment. This is fulfilled by designer and technologist jointly.

2. Selection of the method of assembly and assignment of allowances for the manufacture of basic parts and units. Allowances are designated by the designer and technologist jointly.

3. Division of the technological process into separate operations and determination of the most rational sequence of their fulfillment.

4. Selection of the necessary equipment for the realization of assembly. With the necessity of special equipment for the realization of assembly, for each new unit of equipment one should develop a technical assignment for its designing and manufacture.

5. Selection of the necessary tool and assembly jigs. Composition of assignments for the designing and manufacture of them.

6. Selection of conditions of assembly and calculation of norms of time for their fulfillment.

7. Selection of methods and means of technical control of assembly.

8. Selection of rational methods of the transportation of parts and units for assembly and in process of assembly.

9. Planning of assembly sections of unit assembly and workshop of general assembly.

For the purpose of the reduction of periods of utilization of new or modernized articles, the technologist should proceed toward development of the technological process at the earliest possibly stage of designing of the article, not waiting for the issue of all drawings. In practice the technologist and designer must together work on the creation of a new unit or article. With joint friendly work of the technologist and designer there is achieved good manufacturability of the article, periods of its development are reduced, and considerable economic gain is attained.

In the designing of new articles and development of technological processes special attention should be given to the normalization and standardization of structural elements. The designer sometimes does not ponder the fact that normalization of even such "trifles" as radii of fillets, dimensions of grooves, notches and bases considerably reduces periods of development and labor input and means.

In the development of the technological process of assembly, it is necessary to consider the outlined program of the manufacture of articles and, in accordance with this, to determine how much in detail one should develop the technological process of assembly.

Contemporary state of technology permits conducting an assembly of each article or unit on a conveyer with high mechanization of labor. However, this is not always economically expedient, since expenditures for the creation of expensive conveyers and other means of mechanization are not able to be justified with the small program of manufacture of articles. In these cases it is economically more expedient to have a certain raising of the cost of assembly works.

In the designing of special assembly jigs and equipment one should always consider the perspective of development of articles manufactured by the plant. It is desirable that in the modernization or even development of new articles the technological assembly equipment and rigging be easily adjusted to the assembly of a new article without radical alteration and with minimum expenditures.

Technological process of assembly is composed of appropriate documentation in the form of production flow charts.

In small-lot production the production flow chart is compiled for each collected unit. The chart is supplied with a sketch of the unit with necessary dimensions maintained during assembly. Here technical conditions for assembly are given. Operations and transitions are recorded in the chart in the sequence, which should be maintained during assembly.

In necessary cases the chart is supplied with additional sketches of the unit or some part of it for explanation of the essence of the fulfilled transition, reduction in dimensions maintained during assembly, explanations of methods of measurement and for other technological indications.

In large-lot production the technological process is developed more specifically, and production flow charts are compiled separately for each operation. Each operational chart of the assembly is supplied with a sketch explaining the content of fulfilled operation and technical conditions of assembly is a given operation.

Production flow charts of the assembly are approved by the chief technologist and, in case of especially important assembly processes, by the chief engineer of the plant, and they are the law of the production. Any deviation from the confirmed technological process should be validated and permitted in writing by a person confirming the technology.

In necessary cases, in the technology of assembly, changes are introduced. These changes are formulated by a special "List of changes." The changes are introduced into the production flow chart with reference to the date and number of the list of changes.

loped

ulfilled
ation.

e
ly
e law
ical
on

C H A P T E R 19

EQUIPMENT OF ASSEMBLY WORKSHOPS, TOOL AND DEVICES USED IN THE ASSEMBLY

§ 1. Equipment of Assembly Workshops and Sections

s are
f

nges.

Assembly workshops and sections for the assembly of sets and units, and also for the general assembly of liquid propellant rocket engines must be placed in locations especially adapted for these purposes having good lighting, supply of electric power, compressed air, hot and cold water, steam, etc. The walls and ceilings of the locations must be finished with such materials which will not crumble and dust the location. Floors also must not be sources of dust. The material of the floors should allow humid retracting but not absorb moisture, oil or other contaminations. The temperature in the assembly location should be maintained at a constant level of 18-20°C.

If the ambient air is insufficiently clean, dust, moisture and other contaminations will penetrate into the assembly workshop, settle on parts, units and articles. In these cases air conditioning units are required.

Equipment of assembly workshops and sections can be divided into the following forms:

1. Load-lifting devices: cranes, assembly pulley, etc.

2. Devices for transportation: carts, conveyers, etc.
3. Means for the washing of parts.
4. Heating and drying cabinets, coolers.
5. Installations for hydro- and pneumatic tests.
6. Installations and a machine for balancing.
7. Press.
8. Installations for control.

Load-lifting devices are selected in accordance with the weight and dimensions of loads to be transferred. If it is required to transfer loads over the whole area of the workshop, then an electrical traveling crane is installed. The same crane serves to lift machines during repair, to lift heavy equipment during its installation and for other purposes. For the service of separate sections an electrical self-propelled assembly pulley with a load capacity of 250 to 5000 kg can be installed. The assembly pulley moves along a monorial track or I-beam secured on columns or trusses of the ceiling. The track of the assembly pulley is determined by the direction of the beam. The minimum radius R of the curvature of the track is determined by the dimension of the assembly pulley. With a load capacity of up to 1000 kg the minimum radius of the curvature of the track is $R = 700$ mm. With a load capacity of 1-2 t, $R = 1500$ mm, and with a load capacity of 3 t and higher, $R = 2500$ mm.

Carts for the transportation of articles and units in the process of their assembly move on the floor or along a rail track. Railless carts have wheels (rolls) of small diameter equipped with rubber cast tires. One pair of wheels - usually the front - is made self-oriented for easing the turn of the cart (motion along a curvilinear path). This is attained by the fact that the support of the wheel has vertical axes of rotation on a ball bearing, where the center of the wheel is displaced with respect to the axis of the suspension by a certain magnitude e .

With motion of the cart force is applied to the frame, in which a vertical axis of rotation of the suspension of the wheel is secured.

Under the action of this moving horizontal force, at the first moment movement of the cart by magnitude e occurs without rolling of the wheel.

Consequently, with motion of the cart the turning wheels will always be displaced with respect to axle of the suspension to the side opposite to the motion.

In Fig. 19.1 is shown a railless cart for assembly and movement of units of small dimensions.

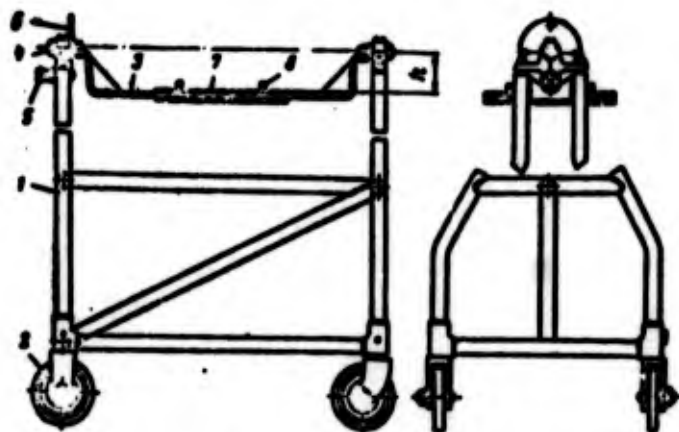

Fig. 19.1. Railless cart for assembly and movement of units: 1 - frame; 2 - wheel; 3 - cradle; 4 - journal of cradle; 5 - stop; 6 - disk of stop; 7 - bearing surface; 8 - adjusting pin.

The base part of the collected unit is set on the support surface 7 of the cradle 3 in such a way that the axis of the collected unit coincides with the axis of rotation of the cradle (on figure the collected unit is not shown). Orientation of the unit along the axis is ensured automatically due to the assigned displacement of the bearing surface and presence on the surface of adjusting pins 8. For the convenience of assembly the unit can be turned at the assigned angle and fixed in this position by the stop 5.

The form and dimensions of the frame and cradle of the cart are designed in reference to specific conditions of the assembly. Sometimes the axis of rotation of the cradle becomes slanted, and the angle of inclination can be constant or variable in the process of assembly.

Carts moving along rail tracks in their upper part are also designed for a specific unit or article. The moving part is fulfilled somewhat differently, in reference to conditions of motion along the assigned rail track.

Presses are used for the creation of the necessary force with the assembly of parts with tightness. Screw, rack, eccentric, hydraulic and pneumatic presses are used.

For small forces hand presses of the bench type are used. A single-sided press develops a force of up to 7.5 kN, and a double-sided - up to 50 kN. To create greater forces, hydraulic and pneumatic presses are used. Hydraulic presses operate more smoothly than do pneumatic presses, and therefore they are given preference in the selection of equipment.

§ 2. Tools and Devices Used in Assembly

The tendency to lower the weight and decrease dimensions of the rocket engine to a maximum compels a designer to use connections with shaped fastening and unfastening parts frequently located in almost inaccessible places. For the execution of such connections special tools - wrenches, screwdrivers, buckers, hammers, center keys - designed and prepared for a specific engine, are required. Let us consider the certain characteristic special tool.

Figure 19.2 shows socket wrenches of various design used for the tightening of nuts located in grooves. The wrenches can be made for a defined dimension of the nut (design a, b, c) or with changeable heads (design d) for nuts of various dimensions. In the

tightening of nuts with socket wrenches the rod of the wrench is disposed along the axis of the bolt. If such a position of the wrench is hindered by other parts, then it is possible to use a hinged socket wrench (e).

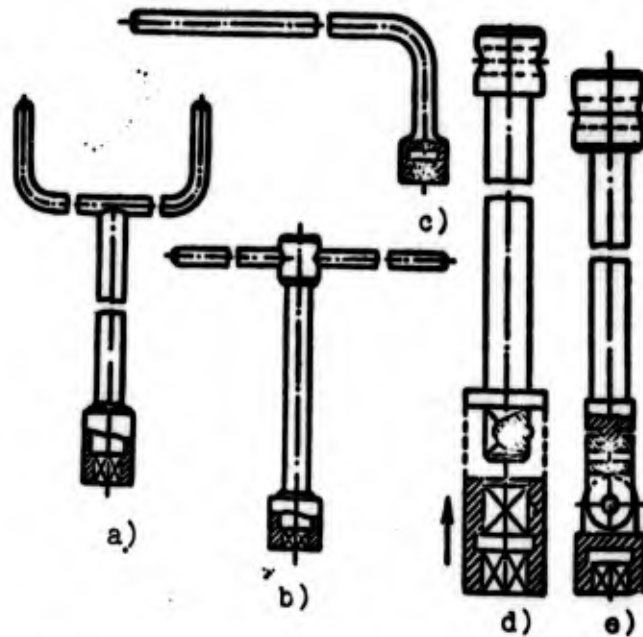

Fig. 19.2. Design of socket wrenches: a) socket wrench with tap wrench for rotation; b) socket wrench with insertable tap wrench; c) wrench with L-shaped handle; d) wrench with detachable head; e) hinged socket wrench.

In this case the axis of the rod of the wrench can be inclined with respect to the axis of the bolt at an angle up to 30° and more.

In Fig. 19.3 are shown characteristic designs of special screwdrivers. Screwdriver the guide (b) is centered on the head of a screw with a spring bushing 2.

To ease the labor and increase the productivity when tightening nuts, screws and pins electrical and pneumatic portable wrenches — power nut setters — are used.

The devices used are divided into universal and special, designed in reference to a specific article. Of universal devices frequently screw clamps for the temporary fastening of parts, prisms, jacks, stripper plates, etc., are used.

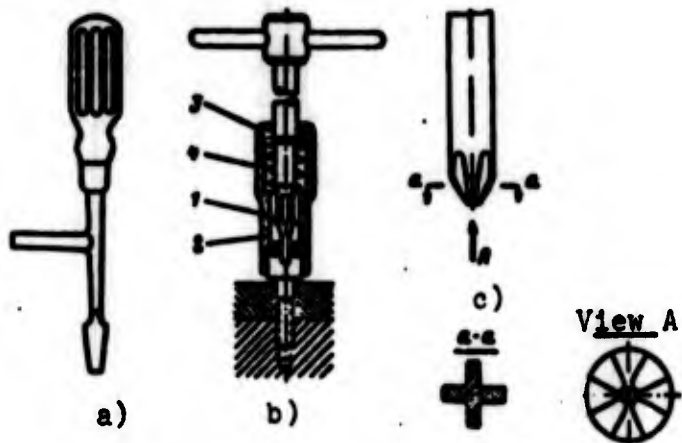

Fig. 19.3. Special screwdrivers: a) screwdriver with tap wrench; b) screwdriver with guide; c) screwdriver for cross-shaped grooves; 1 - screwdriver; 2 - guide bushing; 3 - check ring; 4 - spring.

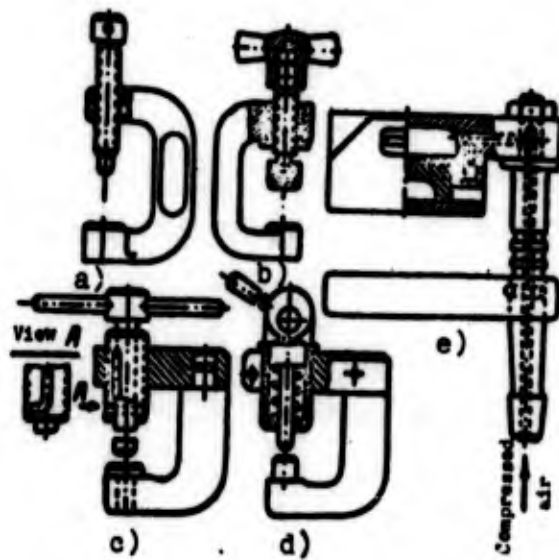

Fig. 19.4. Design varieties of screw clamps: a, b and c) screw; d) eccentric; e) pneumatic.

Figure 19.4 shows model designs of screw clamps.

Figure 19.5 shows three forms of stripper plates. The principle of operation of these stripper plates is clearly seen from the figures.

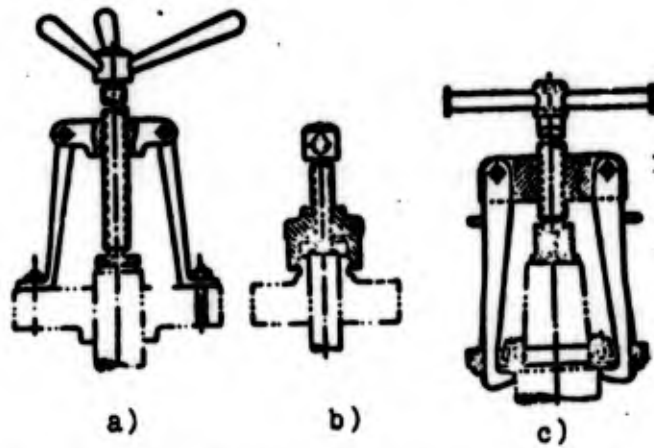

Fig. 19.5. Model designs of stripper plates: a) secured by pins on the casing; b) screwed onto the thread of the casing; c) with hinged grips.

C H A P T E R 20

PREPARATION OF PARTS FOR ASSEMBLY

§ 1. Washing of Parts and Units

All parts and units proceeding for assembly must be thoroughly purified from oxides, oil, moisture, shavings and other contaminations. The units collected from contaminated parts are unfit for operation. It is necessary to consider that even small contaminations can be the cause of disturbance of operation of an engine.

To ensure the necessary cleanness of parts proceeding for assembly, washing and subsequent drying of parts are used. The period of storage of the washed parts prior to their assembly is determined by conditions of storage and the required degree of cleanness of the surfaces. For example, washed degreased parts before brazing can be stored in workshop conditions for several hours.

For washing liquids are used: gasoline, kerosene, alcohol, aqueous solutions, and also vapors of certain substances.

The selection of the washing liquid depends on the material of the part, its configuration and the composition of contaminations (oil, emulsion, shaving, carbon, dust). It is preferable to use water alkali solutions, which are inexpensive, are nontoxic and do not ignite. However, with them it is not always possible to clean well parts of a complex configuration having almost inaccessible places. Therefore, for the washing of complex parts it is necessary

to use petroleum products - gasoline and kerosene, which are good solvents, but these products are dangerous in a fire respect and are harmful for the health.

Washing should be conducted in specially equipped rooms for these purposes having good intake and exhaust ventilation and means of fire-fighting protection.

The method of washing can be by hand or mechanized. The hand method is used in small-lot and experimental production. Hand washing is carried out with the help of brushes, broaches, and napkins in an open bath equipped with local exhaust ventilation. Above the surface of the bath by a fan a certain rarefaction is created in consequence of which vapors of the washing liquid together with the air surrounding the bath rush into the ventilation system.

In Fig. 20.1 is shown a schematic diagram of a bath for the hand washing of parts. The parts to be washed are placed on grid 1, are treated by brushes, broaches and washing liquid proceeding through the flexible hose 4 and nozzle 3. Pressure of the liquid is created by pump 6. The discharged liquid goes through pipeline 9 and flows into the settling tank 8.

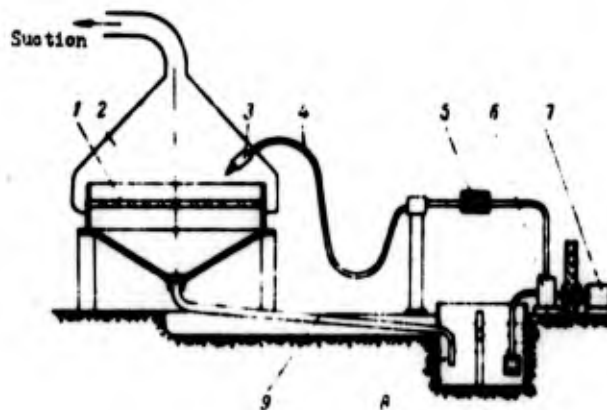

Fig. 20.1. Bath for hand washing of parts: 1 - grid; 2 - ventilation system; 3 - nozzles; 4 - flexible hose; 5 - filter; 6 - pump; 7 - electric motor; 8 - settling tank; 9 - overflow pipeline.

In lot production it is recommended to use the mechanized method of washing. For these purposes industry manufactures special washing machines different design and productivity.

In Fig. 20.2 is shown a diagram of a single-chamber washing machine. The parts for washing move with the help of a loading device 3 on a conveyer belt 7. The washing liquid by pump 1 is pumped into pipeline 4 and through injectors 5 is guided to the parts to be cleaned. Injectors are located above and on sides in such a way to create the best direction of the liquid streams. The discharged liquid flows at the bottom of the bath, is heated by the steam coil 9 and through filter 2 and again enters into the pump.

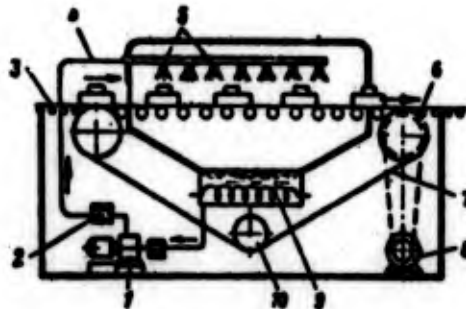

Fig. 20.2. Diagram of a single-chamber washing machine: 1 - pump; 2 - filters; 3 - loading device; 4 - pipeline; 5 - injectors; 6 - receiving roller conveyer; 7 - transporter; 8 - drive of transporter; 9 - coil for preheating washing liquid; 10 - tension drum.

Dual chamber and three-chamber washing machines are also used. In a dual chamber machine first the parts are washed by a washing liquid, and in the second chamber - hot water or some neutralizing solution. At the exit of the three-chamber washing machines there is a drying oven.

Good purification of parts is attained with the help of ultrasonics. The principal diagram of ultrasonic purification of parts proceeding for assembly is similar to that examined by us earlier in Chapter 5 (see Fig. 5.8).

§ 2. Drying of Parts

After washing the parts must be subjected to thorough drying for the removal of moisture. Residues of moisture on surfaces of the parts promote the intense development of the corrosion of metals. Oxidizing the most rapidly are ferrous metals and their alloys and also places of contact of heterogeneous metals where galvanic cells will be formed.

The simplest method of drying is the blowing of parts with dry compressed air. In the flow of air the moisture rapidly evaporates and vapors depart. To increase the effectiveness of drying, the air sometimes is heated.

With lot production the drying of parts is carried out in special drying chambers of periodic or continuous action. In these chambers a circulation of hot air is created. The air saturated by vapors partially departs and is replaced by dry heated air.

Parts of complex configuration with internal almost inaccessible cavities are very difficult to dry by air flow in the drying oven or blowing. In certain cavities of these parts stagnant zones are created with very weak air circulation and, consequently, with slow evaporation of the moisture.

But in precisely these cavities the greatest quantity of moisture from washing remains. A long time is required, so that this moisture is evaporated.

To accelerate process of drying of such complex parts, vacuum drying ovens are used. Dimensions of the ovens are selected according to dimensions of the parts intended for drying. Inside the oven there are grids and supports or suspensions for the parts. The air is pumped by a vacuum pump. Pumps of the type VN-461M, RVN-20, VN-2G, VN-1MG, VN-4G, VN-6G and others are used.

§ 3. Marking of Parts and Packing

All basic parts, subunits and units of a rocket engine are subjected to marking. Marking is carried out by mechanical, chemical or electrical methods.

Mechanical marking is fulfilled by special metallic marks. The necessary letters or figures are rammed by a blow of a hammer on the rod of the mark. Mechanical marking has a very important deficiency - blows of the hammer can lead to the deformation of thin-walled parts.

Chemical marking is based on local etching of the metal by special liquid compositions. The recommended compositions of moistening liquids are given in reference books.

Places subject to marking are cleaned with gasoline and rubbed with lime superimposed on a felt rubbing device. The mark is applied by a rubber stamp with thin lines along the external outline of the letters or figures.

For the wetting of stamps felt or felt pads, which are stored in tightly closed boxes are used. Upon the expiration of 1-2 minutes on the part there appears a text of the mark, after which residues of the liquid are removed by filter paper, and the impression is neutralized by a solution of bicarbonate soda or a 10% solution of calcinated soda. Furthermore, the place of marking is lubricated by an alkaline lubrication, is rubbed dry and is covered by a thin layer of industrial vaseline.

Electrical marking is based on the erosion of metal under the action of electrical current. The marking is conducted with the help of electrograph a diagram of which is shown on Fig. 20.3a. A step-down transformer 1 is connected to an illuminating network by a voltage of 120 or 220 V. The secondary winding of the transformer on one end is connected with a copper plate 3 and other end with a tip 2 with a tungsten electrode. The part subject to marking is put on plate 3 and is thus connected to the circuit of the secondary winding of the transformer. The required mark is written with the electrode. The voltage of the secondary winding is approximately 1.5 V.

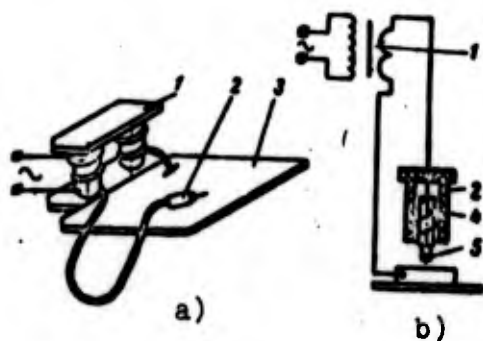

Fig. 20.3. Diagrams of instruments for electrical marking: a) electrograph; b) instrument for electric-contact marking; 1 - transformer; 2 - tip; 3 - plate; 4 - core; 5 - marker.

Application of a mark by an electrograph is fulfilled by the hand method, and therefore the speed of marking and quality of the signs depends on the skill of the worker. In connection with this with large groups of monotypic parts, it is expedient to use instruments for electric-contact marking, which are prepared according to the diagram of Fig. 20.3b. The instrument consists of a step-down transformer 1 and tip 2 with an iron core 4. Fastened to the end of this core is an electrode - marker 5 of a copper-graphite mass. With marking the electrode touches the part for 1-2 seconds.

The parts washed, dried and prepared for assembly are subjected to anticorrosional treatment and packed in special packing for storage and transportation to the place of assembly.

The form and dimension of the packing depend on design of the parts and condition of their storage. Parts intended for prolonged storage are covered with special lubricants using mineral oil as a base with an impurity of rosin and stabilizers. Instead of the applying of lubricants, it is possible to wrap the parts in oiled paper or cover them with a thin film of vinyl chloride or polyethylene.

§ 4. Protective Coatings

All parts and units of a liquid propellant rocket engine must possess high anticorrosive properties for protecting them from the action of atmospheric air on the process of transportation and storage. Furthermore, surfaces coming into contact with fuel components or with combustion products, must possess anticorrosive properties for protection from the action of these components or products.

Methods of protection from corrosion are diverse. Rust-resistant and acid-resistant materials, coating of the surface of oxidizing metals by other metals not oxidizing, formation on surfaces of oxide protective films, varnish and paint coatings and others are used. The method of protection is selected by the designer depending upon conditions of operation or units in the engine.

The place of operations with respect to the formation of protective coverings in the common technological process is determined by the technologist depending upon character of assembly and method of applying the coating.

Certain parts move on assembly in a prepared state protected from corrosion. Other parts or units pass operations of protection from corrosion after the assembly.

Let us consider briefly some of the most characteristic methods of the formation of protective coatings.

Electroplatings. The method of electroplating is based on the separation of metals from solutions of their salts under the action of electrical current. Deposition of the metal on the surface of a part occurs with the connection of it to the negative pole of the source of current, i.e., the part is the cathode. The second electrode, connected to the positive pole of the source of current, is called the anode.

Before electroplating the parts undergo preliminary preparation: degreasing, etching, washing, etc.

The content of preparatory operations depends on the material of the part, state of its surface and kind of metal of the coating: zinc, cadmium, chromium. Certain parts according to technical conditions of their operation must have a coating not continuous over the entire surface, but partial on separate sections. In this case before coating, the sections not subject to coating are insulated. The material of insulation used is different depending upon the composition of the bath. For example, for the insulation of sections with chrome plating the stablest material is teflon-4 (teflon) and also polyvinyl chloride plastic. With zincing for the protection of sections, it is possible to use collars of thin sheet steel.

The sequence of operations of the technological process of zincing of parts after machining in acid electrolytes following:

1. Washing in solvents.
2. Installation of parts on suspensions.
3. Electrochemical degreasing.
4. Washing in hot and cold water.
5. Pickling (etching).
6. Washing in cold water.
7. Zincing.
8. Washing in cold water.
9. Clarification.

10. Washing in cold water.
11. Passivation.
12. Washing in cold and hot water.
13. Drying.
14. Dismantling from suspensions.

If on surface of the parts there are scales, then before these operations the surfaces are cleaned of the scales by sandblasting or another method.

The content of the enumerated operations can be clearly seen from their names, except for operations 9 (clarification) and 11 (passivation).

Clarification of the coating is fulfilled by submersion of the part into a solution for 1-3 seconds: chrome anhydride, 150 g/l, sulfuric acid, 3-5 g/l, and nitric acid, 50 g/l.

Passivation is fulfilled for the purpose of increasing the corrosion resistance of the coatings. For passivation the parts are submerged into special solutions for 5-10 seconds.

In electroplating by cadmium, chromium and other metals, the basic scheme of the process remains the same as that with zincing, but certain operations are excluded or are replaced by others.

Metallizing is the spraying of molten metal on the surface of the part. The essence of the process of metallizing was examined earlier in § 6 of Chapter 6.

Oxidizing is the artificial oxidation of the surface of the parts with the formation of oxide films, which protect the parts from corrosion. Both ferrous and nonferrous metals are subjected to oxidizing.

Oxide films on ferrous metals consist basically of magnetic iron oxide. The color of the films depends on the method of their obtaining, thickness, brand of the metal and form of heat treatment. It can be golden yellow, violet, bluish black, and black.

The thickness of the films depends on the composition of the solution and conditions of treatment: from 0.5-0.8 μm with alkaline burnishing up to 10 μm with high-temperature treatment in steam.

The corrosion resistance of oxide films on carbon steels is comparatively low and inferior many times to phosphate films.

The oxidizing of stainless steels of the type 1Kh18N9T is fulfilled by air-thermal means. The parts at first degreased and subjected to electrolytic polishing. Then after washing, passivation and drying, oxidizing at a temperature of 420°C for 55-60 minutes is conducted. An oxide film with a thickness of about 0.6 μm has a golden color.

For the oxidizing of aluminum and its alloys, first anode treatment is conducted for 2-3 minutes in an aqueous solution of trisodium phosphate and caustic soda. Then there follows the operation of the clarification (for the removal of ferrous deposit of alloying elements), after which oxidizing in special solutions is conducted. Oxidizing in 15-20 percent solutions of sulfuric acid with an anode current density of 1-2 A/dm^2 is widely used. Lead is used as the cathode. The time of exposure depends on the assignment of the oxide film. An oxide film of a delicately white color with a thickness of 4-5 μm is not scaled from the metal, has high hardness and serves as reliable protection from corrosion. The oxide film has a microporous structure. Filling of the pores with bichromate or varnish and paint coatings increases the corrosion resistance of the oxide film. For the photochemical manufacture of different scales and tablets, the porous oxide film is impregnated with photosensitive salts.

The most frequently used to increase anticorrosive properties is passivation - the exposure of parts in a solution of bichromate at a temperature of 80-90°C for 10 minutes. Pores of the film in this case are impregnated passivator, obtaining lemon yellow color.

To increase the wear resistance with friction of parts from aluminum alloys, is used a process of deep anode oxidizing in a 20% solution of sulfuric acid at a temperature of -10° to -6°C and anode density of 2.5 A/dm². Here an oxide film of high hardness with a thickness of 20-30 μm is obtained. Other methods of oxidizing of the aluminum, for example, anode enameling, which possesses high anticorrosive and electroinsulating properties, electroinsulating oxidizing and others are used.

Parkerizing is a chemical process of the formation on the surface of the metal of a protective film. The parkerizing of steel is conducted under the action of the solution of the preparation of "manganese ferric phosphate."

This preparation (All Union Government Standard 6193-52) received the name from initial letters of its component parts - manganese, iron and phosphoric acid. The thickness of the phosphate film varies from 7 to 50 μm depending upon the method of preparation of the surface and conditions of parkerizing. The film formed is linked well with the basic metal, is porous, absorbs varnishes well, paint and lubrication, and also possesses high corrosion resistance with respect to the majority of combustible and lubricating oils. In aggressive media, for example, in acids, alkalis and ammonia, the phosphate film is unstable. The phosphate film is frequently used instead of priming for color.

Parkerizing finds application also in certain special cases, for example, the preparation of the surface before nitration for the purpose of increasing the hardness, for improvement of running-in of parts and the preventing of burrs.

Varnish and paint coatings. Materials for varnish and paint coatings are selected depending upon technical requirements for the surface of the parts. The process of the applying of varnish and paint coating consists of three basic stages.

1. Preliminary preparation of the surface of the part.
2. Applying the coating.
3. Finishing (used if needed).

Preparation of the surface consists in the cleaning and applying of a priming layer for the purpose of a more durable cohesion of the surface with a subsequent layer of the coating. Industry manufactures different priming materials. If it is necessary to level the surface, there is used a filler (lubrication), which is applied by steel or wooden spatulas or a piece of rubber on the primed surface. The thickness of the layer of the filler is not more than 0.5 mm. When necessary a second layer is applied after the drying of the first. To correct the small unevennesses a special filler applied by atomization is used. On the prepared and dried surface a paint layer of a composition required by the TU is applied.

The process of applying varnish and paint materials is conducted in a location specially equipped for these purposes from good inflow and exhaust ventilation. The spraying of the priming, varnish and paint can be fulfilled by a tool or automatically.

The drying of varnish and paint materials can be natural or artificial. Natural drying is used for quick-drying varnish and paint materials (nitroenamels, perchlorvinyl enamel) and consists in a natural evaporation of highly volatile solvents. The painted parts or articles are placed into exhaust chambers for the removal of harmful vapors of solvents.

Artificial drying is carried out in special chambers by convective, radiation or inductive methods.

In a convective drying oven drying is conducted by air heated to 60-220°C.

In radiation drying (radiant energy) the painted surface is rapidly heated to 150-180°C by infrared radiation of reflectors. The period of drying in this case is reduced 3-10 times as compared to drying by heated air.

Induction drying by currents of high frequency requires considerable power consumption and is used in special cases.

Plasma spraying is used for applying thin protective films in those cases when other methods cannot do this. Plasma spraying is conducted in a vacuum.

C H A P T E R 21

FULFILLMENT OF ASSEMBLY CONNECTIONS

Connections used in the assembly of a liquid propellant rocket engine and their subassemblies and units can be conditionally divided into fixed and movable.

Fixed connections, in turn, are divided into nondetachable and detachable.

Fixed nondetachable connections pertain to connections by welding, brazing, gluing and the mechanical method.

Fixed detachable connections are those by threads on parts or special threaded parts - bolts, screws, woodscrews, and also grooving connections - keys and slits and connection with guaranteed tightness.

Movable connections are made mainly on roller or slider-type bearings. This group of connections includes packings, which play a great role in liquid propellant rocket engines.

§ 1. Nondetachable connections

Nondetachable connections are such connections which do not permit disassembling the construction without the destruction of parts or connections between the parts. In a liquid propellant rocket engine the most widespread nondetachable connections are the welded and brazed ones. The technology of the fulfillment of welded

and brazed connections was examined by us earlier in detail (see Chapters 5 and 6).

Connections by gluing and the mechanical method are used comparatively less often.

Of mechanical connections by rivets, rolling under and locking are used. Figure 21.1 shows the most typical mechanical connections. On diagrams a and b connections by rivets are shown. The formation of a round head is attained by upsetting, which has deepening according to the form of the head. The necessary length of the rod of the rivet is determined from the condition of equality of the volume of the future head and protruding part of the rod to its unriveting.

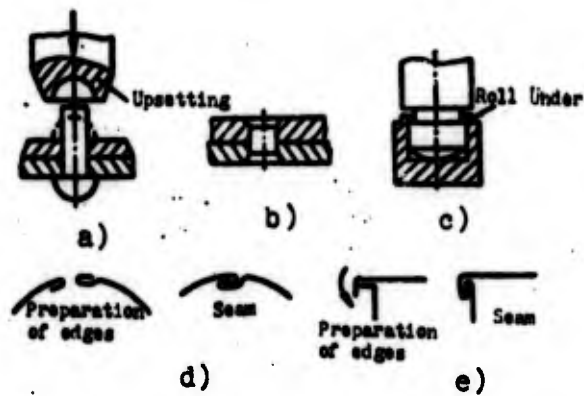

Fig. 21.1. Mechanical connections.

Diagram c shows an example of the connection of a valve with a rod by rolling under the edges of the valve.

Diagram d shows the connection of edges of the thin-walled cylindrical part by a longitudinal lock seam. The edges are preliminarily unbended on bending machines, as was shown on the diagram on the left. Then the bends are connected, and the seam is sealed by blows of a hammer or press.

Diagram e shows a connection of a cylindrical thin-walled part with a thin-walled base by an angular or bottom lock seam.

In necessary cases for the creation of airtightness, lock seams are sealed by solder, glue, putty or another method.

Gluing of parts has a number of advantages: the possibility of the connection of metals with nonmetallic materials (with textolite, foam plastic, rubber); the connection of very thin sheet materials; the absence or lowering of the concentration of stresses.

Deficiencies of glue connections are: unequal strength at different directions of the application of a load with respect to the plane of gluing; lowering of the strength of certain glues over the course of time (aging); the necessity of strict observance of the technological process and absence of reliable methods of control of the quality of glue connections without their destruction. At present there are several dozen brands of commercial glues possessing different physical and mechanical properties. The most frequently used glues for gluing metals with each other and with nonmetallic materials are glues of the type BF (phenolpolyvinylacetal); MPF (methylpolyamidephenol); VS (phenolpolyvinylacetal); VIAM B-3 (phenolformaldehyde). The strength of these glues is comparatively high. For example, the glue BF-2 with the gluing of steel 30KhGSA (surface blasted by sand) has a shearing strength of 35-37 MN/m².

The technological process of gluing consists of the preparation of the surface, application of the glue and holding under pressure and with preheating.

Noncritical connections can be glued without pressure, but at this point the strength of the connection noticeably decreases.

§ 2. Detachable Connections

Thread Connections

Thread connections are the most widespread form of fixed detachable connections of parts and subassemblies of a liquid propellant rocket engine. They are carried out with the help of bolts, screws and pins. Connections with the help threads on joinable parts are also used. Thread connections are accumulated without tightening or with preliminary guarantee tightening, which is installed by the TU for assembly. Preliminary tightening is made so that the joint does not open under the action of an applied working load under conditions of operation and the connection is not disturbed. The opening of the joint can occur as a result of lengthening of the bolt (screw, pin) under the action of applied a working load to it at an insufficient magnitude of tightening. On the other hand, excessive tightening causes in the material of the bolt unnecessary stresses, which, being added to the operating stresses, can lead to destruction of the bolt.

Therefore, with assembly of the tightened thread connections control of compression force is necessary. The compression force in industrial conditions is determined by one of the following methods:

- 1) by torque applied to the nut;
- 2) by lengthening of the bolt (pin);
- 3) by the angle of turn of the nut.

The first method consists in the fact that with the help of a dynamometric wrench applied to the nut is such torque which causes the necessary compression force. The relation between the moment $M_{\text{зат}}$ and compression force $P_{\text{зат}}$ is the following:

$$M_{\text{зат}} = P_{\text{зат}} \left[\frac{d_2}{2} \lg(3 + \theta) + \frac{D + d_n}{4} f \right],$$

where d_2 - average diameter of the thread; β - lead angle of the thread; ρ - angle of friction in the thread; D - diameter of support surface of the nut (equal to the dimension under the wrench); d_0 - diameter of hole under the bolt; f - coefficient of friction between the end of the nut and support surface of the part.

To measure the moment of tightening dynamometric wrenches of different design are used. Figure 21.2 shows hand dynamometric wrenches founded on the measurement of sag of the rod of the wrench under the action of the force of the worker. The process of tightening of a nut by such a wrench should be carried out smoothly without jerks, gradually approaching the assigned moment, which requires skill of the worker.

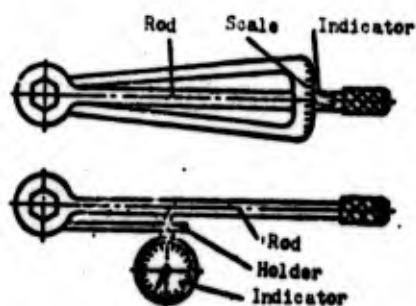

Fig. 21.2. Dynamometric wrenches.

In lot production wrenches of limiting moment are used. With vertical separation of the assigned moment the coupling, which links the head of the wrench with the spindle, emerges from engagement, and rotation of the nut stops.

The method of control of compression force by torque gives great errors, since the moment of tightening depends on the coefficient of friction in the thread and on the end of the nut, which changes over a wide range from 0.05 to 0.4 depending upon the state of the surface and also on the accuracy of manufacture and other factors. For example, the same moment on the wrench with screwing up of a degreased thread gives 6-8 times smaller compression force than with the screwing up of a thread lubricated by animal fat. Therefore,

it is required always to observe strictly identical conditions with tightening.

The second method of control of compression force - by lengthening of the bolt (or pin) is more accurate. It is based on the law of Hooke:

$$\Delta l = \frac{P_{\text{HT}} l}{EF},$$

where Δl - linear lengthening of the bolt; l - length of the bolt; E - modulus of longitudinal elasticity; F - area of cross section of the bolt.

Using this law, it is possible to calculate to what magnitude the bolt should be extended so that in it the required compression force appears. To determine the magnitude of lengthening, the length of the bolt (or pin) before and after tightening is measured. Measurement should be fulfilled by micrometers with sufficient accuracy with support of the measuring rods at the same place. This is conditional by the fact that lengthenings of bolts with tightening is small (especially short bolts), and errors in measurements give great errors in the compression force.

The third method of control of tightening - by angle of turn of the nut after its end has stopped in surface of the tightened part - is based on the following reasoning. The compression force of the bolt is proportional to deformation Δ :

$$P_{\text{HT}} = \Delta C, \quad (\text{a})$$

where Δ - deformation; C - given rigidity of the joint, which can be calculated beforehand.

Deformation can be expressed in terms of pitch s of the screw and angle of rotation of the nut α :

$$\Delta = \frac{s\alpha}{360^\circ}.$$

Consequently, equation (a) can be expressed in the form

$$P_{\text{nut}} = \frac{mC}{360^\circ} \quad (b)$$

Hence we find the necessary calculation angle α_p of turn of the nut for obtaining the required compression force:

$$\alpha_p = \frac{360^\circ P_{\text{nut}}}{sC}$$

The advantage of this method of control of compression force as compared to the first method consists in the fact that this control does not depend on the coefficient of friction, which, as was already noted, is changed over a wide range. A deficiency of the third method of determination of compression force is the fact that it is difficult to determine the beginning of reading of the angle of rotation of the nut. By numerous experiments it has been established that the beginning of tightening does not coincide with the moment of rest of the end of nut in the plane of the flange. It is recommended to produce tightening at an angle where

$$\alpha = \alpha_p + \alpha_0$$

where α_0 - preliminary angle of rotation of the nut, determined by experimental means.

For guaranteed tightening of bolts and pins sometimes special torque washers are used.

Maintaining the guaranteed tightening during the work of the connection depends, furthermore, on the thoroughness of fitting of the joints, order of tightening of bolts in the group connection and reliability of locking of the nuts against self-unscrewing. Therefore, with assembly of the connection one should check the thoroughness of fitting of the parts and fulfill preliminary setting of the connection by means of tightening of bolts by the assigned force. In the group connection of the nut one should tighten

gradually in two-three procedures; first, tighten all nuts one third, then two thirds and, finally, on full tightening. It is necessary, furthermore, to observe a definite order of tightening. Nuts, located circularly, should be tightened criss-cross. With location of the nuts in a row, first the middle nuts are tightened and then those located in a row, etc.

To prevent self-unscrewing, the nuts are locked. Figure 21.3 gives the most commonly used methods of locking.

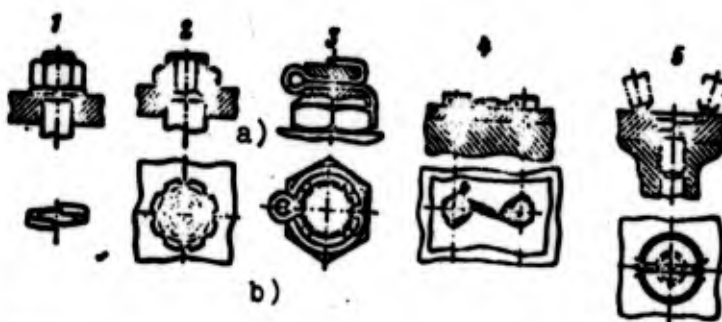

Fig. 21.3. Most commonly used methods of locking of nuts: 1 - washer spring; 2 - locking washer; 3 - splint pin (bend of ends can be according to diagram a or b); 4 - wire; 5 - center punching.

Grooving Connections

Grooving connections include key and spline fittings.

Key connections can be with both one and two keys (Fig. 21.4a). The key is set into the groove of the shaft tightly or with negative allowance, but in the groove of the nave a less tight fit is created. Embracing the shaft the part (nave) should be centered only along the neck of the shaft, and between the upper plane of the key and bottom of the groove in the nave there should be a clearance.

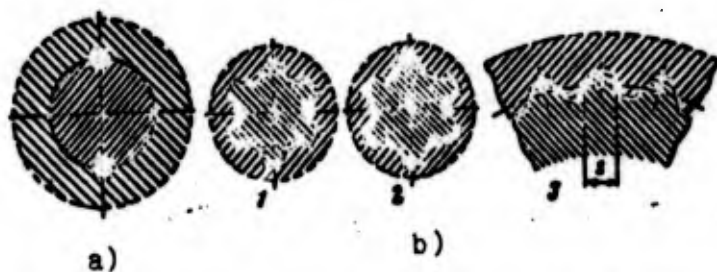

Fig. 21.4. Grooving connections; a) key;
b) slit.

It is recommended to fulfill the tight fit of the keys with the help of a press or special devices. In case when high accuracy of assembly is required, individual fitting of the keys is made. First lateral walls of the groove are scraped and their parallelism (correct to 0.01-0.02 mm on 200 mm of length) and the width of the groove according to gauge are checked, but then along the slot the key is scraped.

Spline fittings are distinguished by the method of centering of the shaft. Figure 21.4b shows three methods of centering: 1 - along the external diameter; 2 - along the internal diameter; 3 - along lateral surfaces of the slits. With the assembly of the spline fitting special attention is given to the accuracy of fitting in a radial direction. Radial errors of masses lead to unbalanced masses of the gathered unit and must be reduced to minimum.

Spline fittings can be slowly detachable, easily detachable and mobile. This is attained by the appropriate selection of the fittings: with centering along the external diameter $\frac{A}{C}$, $\frac{A}{X}$, $\frac{A_{2a}}{X}$; with centering along the internal diameter $\frac{A}{r}$, $\frac{A}{\Pi}$, $\frac{A}{D}$, $\frac{A}{X}$, $\frac{A}{\Lambda}$.

Due to small allowances for the manufacture of parts, the assembly of spline fittings is conducted by means of selection, since the full interchangeability is usually not attained.

By means of tests there is also found such a position of parts by the angle of turn at which the connection is the easiest. This position is fixed by marking of the slit of one part and the groove

of the other part. Before assembly the state of the surface of slits and grooves for the absence of nicks, burrs, small scores and other defects should be thoroughly checked. The presence of defects of the surface can lead to seizing with assembly. With close fits assembly is carried out with the help of a press. Assembly by blows of a hammer is not recommended.

Heating of the female part before tight pressing to 80-120°C is also used.

Connection with Guaranteed Negative Allowance

These connections are fulfilled by the following methods:

1. Pressure of a press at normal temperature.
2. Heating of the female part.
3. Cooling of the male part.
4. Combined method (combination of the 2nd or 3rd with the 1st or combination of the 2nd and the 3rd).

Selection of the method of assembly depends on the design of the parts (thickness of walls, dimensions), material of the parts and on the magnitude of the assigned interference. With small negative allowances (0.02-0.04 mm) usually pressing with a press at normal temperature is used. The assembly of connections with large negative allowances at normal temperature requires the application of great forces with pressing, which can lead to damage of the parts. Therefore, it is recommended to heat the female part and cool the male part. Preheating is conducted in an air medium or in a liquid bath. Preference is given to heating by air, since the part remains dry and clean. The parts are cooled in coolers with a different cooling medium: solid carbon dioxide (dry ice), liquid air and nitrogen.

Fittings with heating or cooling of the parts give a stronger connection (2-2.5 times) than that by pressing at normal temperature.

§ 3. Movable Connections

Movable connections in a liquid propellant rocket engine are fulfilled on plain or roller bearings.

Plain bearings operate under conditions of semiliquid (boundary) or liquid friction. With semiliquid friction, which is observed with a small number of revolutions, contact of the journal of the shaft and bearing bushing occurs, which leads to the appearance of a considerable frictional force and wear of the bushing. Upon the achievement of a definite number of revolutions, there occurs "emersion" of shaft journal and transition to liquid friction with a sharp drop in losses to friction. This occurs due to the fact that with rotation of the shaft the oil is pulled into the clearance between the shaft and bushing, an oil wedge will be formed (Fig. 21.5a) and there appears hydrodynamic lift T , which raises the shaft. Subsequently, the shaft revolves, not touching the bushing, and losses to friction are very small - they are caused only by the friction in the liquid. Wear of the bushing does not occur.

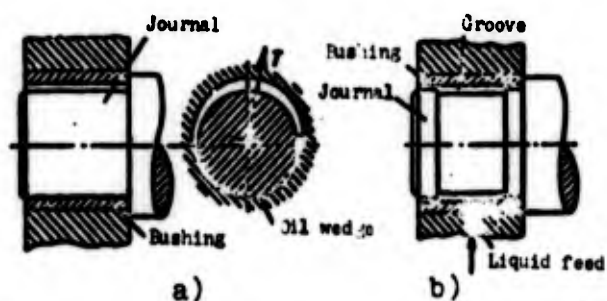

Fig. 21.5. Plain bearings:
a) liquid friction; b) hydrostatic.

Conditions of liquid friction depends not only on the number of revolutions but also on the magnitude of diametrical clearance between the shaft and bushing, which is within 0.06-0.2 mm. Therefore, with the assembly of bearings it is very important to maintain this clearance assigned by the designer. The internal surface of the bushings of important bearings has an antifriction layer of the

babbit, bronze or silver. This surface prior to assembly is machined finally, is sometimes lead-plated and is impregnated with indium. The fitting of such a bushing on a shaft by means of scraping or reaming is not allowed. The assigned clearance between the bushing of the fitting of halves of the bushing on places of the joint.

A considerable effect on the efficiency of the bearing is rendered by the fitting of the bushing into the casing. Best results are obtained in the fitting of a bushing with considerable negative allowance (0.03-0.05 mm) distributed evenly over the whole area of contact of the bushing. The control of the degree of adjoining of the bushing is conducted by paint (for detachable connections) or by measurement of dimensions of the socket and bushing in two-three sections.

Recently hydrostatic bearings, the principle of operation of which is shown on Fig. 21.5b has found application. Liquid or gas with a certain pressure is fed from below under the journal of the shaft through a series of holes, enters into the annular groove and flows out through clearances between the shaft and bushing.

Since clearances in the upper part of the bearing are larger than that in the lower part, then the leakage of gas or liquid in the upper part is also larger. Consequently, a pressure drop of liquid or gas is created, as a result of which the journal of the shaft "emerges" and revolves without contact of the bushing.

The efficiency of such bearings depends, mainly, on radial clearances between the journal and bushing. Therefore, with assembly it is necessary to maintain these clearances with great accuracy by means of the selection of bushings. The optimum clearance lies within 0.04-0.06 mm. For the limitation of undesirable end leakages of gas or liquid, in the bearings end packings are made, and they must be thoroughly made and checked by the magnitude of leakage in a working state.

Roller bearings are used in a liquid propellant rocket engine considerably more frequently than are plain bearings. According to the accuracy of manufacture standard roller bearings are divided into 5 classes of accuracy; H - normal class; П - increased; B - high; A - especially high; C - superhigh.

It is necessary to keep in mind that the cost of bearings depends on the class of accuracy. If one were to take the cost of the bearing of class H as one unit, then the cost of such a bearing of class A consists of four units, and the bearing of class C is more expensive than the bearing of class H by ten times. In important units of the liquid propellant rocket engine, for example, in the turbopump unit, are bearings of classes A and C are used, which is dictated by the necessity of the installation of shafts with small radial clearances. Displacement of the center of gravity of rapidly rotating masses by a magnitude of a total of 2-3 μm causes harmful vibrations. Therefore, sockets under the bearings and necks of the shafts must be treated very thoroughly and accurately, and the fit of the bearings should be fulfilled with the assigned negative allowance or clearance. Most frequently two forms of fits are used: 1) on a shaft - with negative allowance, and in the casing - on a sliding fit or with small clearance; 2) on a shaft - on a sliding fit, and in the casing - with negative allowance.

In the determination of radial clearance in the bearing, after assembly one should consider the decrease in design clearance of the bearing (design clearances are given in catalogs on bearings) after its installation due to the decrease in the external ring pressed into the casing or due to the increase in the internal ring pressed into the shaft.

Measurement of the true radial clearance after installation of the bearing is difficult. In industrial conditions it is determined indirectly according to the magnitude of the axial clearance connected with the radial clearance.

There are special tables of the determination of radial clearance with respect to the axial clearance.

With assembly of the bearings it is necessary to observe complete cleanness. The entrance of dust and other contaminations - especially on the race path of the bearing - is not allowed. Preservation of the bearings is carried out directly before assembly by means of washing them in pure gasoline and subsequent drying with dry air. Then it is necessary to be convinced of the absence of traces of corrosion and to check the evenness and lightness of movement. The inspection and checking must be conducted in clean dry gloves. After inspection the bearings are rinsed in pure spindle oil.

The bearings should be installed with the help of special devices for a uniform, without misalignments, application of the force to the ring of the bearing.

With a close fit of the bearings the force of pressing should be applied to that ring which has a close fit. If this is not observed, and the force is applied to the ring having a sliding fit, then the force of pressing will be transmitted through the rolling bodies, which will damage the bearing.

If after installation of the bearing rotation becomes tight, then the bearing is removed and in its place a new one is put. For removal of the bearings special stripper plates are used, (see Fig. 19.5).

Packings. The most widespread forms of packings are shown in Fig. 21.6. The assembly of these packings in many respects is determined by their design:

a) the collar packing is insensitive to great tolerances for manufacture of shafts, since the adjoining of the whiskers of the rubber collar 1 to the shaft is ensured by the pressure of the spring 4.

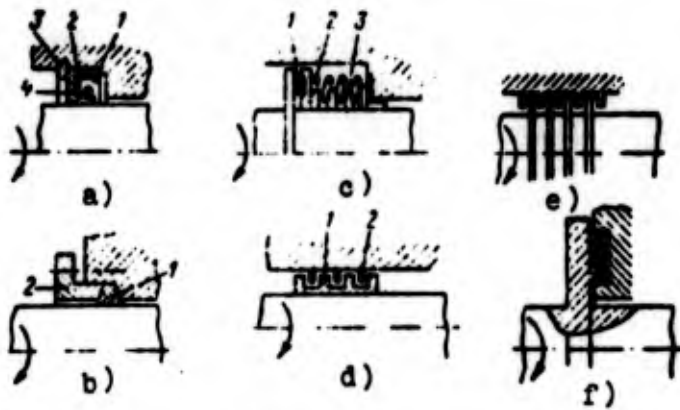

Fig. 21.6. Packings: a) collar (1 - collar; 2 - ring of rigidity; 3 - check ring; 4 - spring); b) stuffing box (1 - stuffing box filling; 2 - bushing); c) bellows (1 - graphite ring; 2 - spring; 3 - bellows); d) annular (1 - bushing; 2 - sealing ring); e) labyrinth radial; f) labyrinth butt.

To create rigidity the collar is reinforced with a metallic ring 2. The collar is set into the casing and is fixed by spring check ring 3, which moves into groove in the casing. With rotation of the shaft the whisker of the collar rubs against the shaft, which causes a loss to friction. In order to decrease these losses, the surface of the shaft should have an appropriate degree of cleanness of the surface, depending upon the kind of rubber. For the same purpose special lubrications are used;

b) a packing-gland seal provides the regulation of pressure on the stuffing box by the pulling of the bushing 2. To decrease losses to friction, the stuffing box filling 1 is impregnated by a special composition (for example, a mixture of lubrication with graphite).

Packing-gland seals are used, mainly, in units with slow rotation of the shaft, for example, in valves;

c) bellows seals can operate at increased temperature (up to 700°C and above) and also under conditions of a vacuum. The packing consists of a bellows 3 and packing ring with a graphite insert 1. For a reliable contact of the friction surfaces, spring 2 is provided.

Assembly of the bellows seal starts from the bracing of bellows to the casing by means of brazing, seam roll welding, gluing or other method. Then dressing of the seam and a test of its airtightness are produced. Length of the bellows in a free state should be such that after installation of the shaft the rated pressure of the sealing graphite ring 1 onto the shaft shoulder is created;

d) the annular packing consists of a bushing 1 and sealing elastic rings 2 entering into grooves of the bushing. For the correct operation of the packing, the rings must possess approximately identical elasticity. For this purpose the rings are preliminarily tested for elasticity and are completed by groups. The rings must be installed without misalignments with a small force in order not to break the ring. It is recommended to make the magnitude of side play between the ring and groove of the bushing 0.05-0.07 mm for packings working at a normal temperature and 0.06-0.09 mm - at an increased temperature;

e) labyrinth seals are based on the loss of pressure of the liquid or gas with flow through the narrow slots. An increase in clearances in the packing above the calculated (assigned by drawing) disturbs the operation of the packing. Therefore, with the assembly of labyrinth seals the basic attention is given to the achievement of the assigned clearances.

Assembly of the packing, shown on diagram e, is possible only with a split female bushing. The magnitude of the radial clearance can be regulated by the approach of elements of the split bushing.

Clearances in butt packings (according to diagram f) can be regulated by the axial movement of the shaft.

CHAPTER 22

ACCURACY OF ASSEMBLY BALANCING

§ 1. Accuracy of Assembly

The assembly of the subassembly, unit or engine on the whole should be carried out with an assigned accuracy of the relative position of the parts in order to ensure reliable operation under operating conditions. Each part proceeding for assembly has its own real dimensions within limits of an allowance for its manufacture. With the assembly the parts, in touching each other, will form measured chains, into which enter parts with their real dimensions. Thus, the overall dimension of chain will be different for every subassembly collected.

Let us consider assembly of the simplest subassembly, consisting of three parts, depicted on Fig. 22.1a. Installed into the casing 2 is bushing 3, and it is secured by bushing 1. The mating dimensions are the following: $A_1 = 20^{+0.1}$; $A_2 = 8_{-0.1}$; $A_3 = 12_{-0.1}$. With the fulfillment of these dimensions with respect to nominal values, all three parts in the subassembly will touch each other in an axial direction. If, however, dimension A_1 is fulfilled according to the maximum allowance and dimensions A_2 and A_3 with respect to a lower allowance, then in the subassembly between the parts an axial clearance Δ equal to the sum of all allowances, i.e., 0.3 mm will be formed.

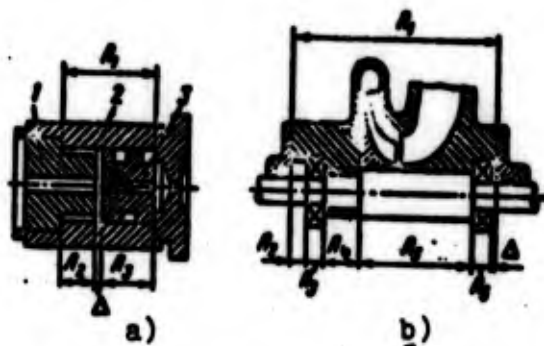

Fig. 22.1. Measured chains:
 a) assembly of a subassembly of three parts; b) assembly of a pump; 1 - bushing; 2 - casing; 3 - insert.

In real industrial conditions extreme values of allowances are rarely observed, and, consequently, the clearance Δ will be somewhere between zero and 0.3 mm. If according to conditions of operation this clearance is not allowed, then one should install a compensator (for example, fitted packing) or provide movement of the locking link. In the examined subassembly dimension A_2 can be fulfilled knowingly larger than the face value, and on the left part 1 can be pressed down, for example, by rolling in the left edge of the casing.

The measured chains are calculated by the designer in the development of the assembly drawings. However, the technologist must sometimes introduce essential corrections into these calculations in reference to concrete conditions of production.

Three methods of calculation of measured chains are used:

- 1) for the maximum and minimum;
- 2) quadratic addition of errors;
- 3) combined method.

1. Calculation for the maximum and minimum is fulfilled on the assumption that all parts entering into assembly are carried out with the least favorable maximum deviations. The allowance of the

locking link is found as the sum of allowances of component links which is written in such a form:

$$\delta_{\Delta} = \sum \delta_{A_i}$$

where δ_{Δ} - allowance for the locking link; δ_{A_i} - allowance for the component link.

Let us explain this with an example. Let us assume that it is required to calculate the measured chain with assembly of the subassembly depicted on Fig. 22.1b. The dimensions of the links entering it are the following:

$$A_1 = 200^{+0.3};$$

$$A_2 = 10_{-0.1};$$

$$A_3 = 20_{-0.06};$$

$$A_4 = 40_{-0.2};$$

$$A_5 = 110_{-0.2};$$

$$A_6 = 20_{-0.06}.$$

As a result of the calculation, it is required to determine the magnitude of the allowance on the locking link, which in the given subassembly is the clearance Δ .

Using the above formula, let us find the expected oscillation (allowance) of clearance Δ :

$$\delta_{\Delta} = 0.3 + 0.1 + 0.05 + 0.2 + 0.2 + 0.06 = 0.92 \text{ mm.}$$

Consequently, if according to conditions of assembly of the given subassembly an axial clearance is not allowed, (i.e., $\Delta = 0$), then one should provide the installation of a compensating washer or individual fitting of the locking part (for example, shoulder of the left cover).

Calculation for a maximum and minimum gives oversized values of the allowance, since such an extreme case is encountered very rarely in order that for assembly of a subassembly having only maximum deviations are used.

2. The method of the quadratic addition of errors is based on the assumption that for assembly parts with different deviations are used. The probability of the appearance of deviations obeys the law of normal distribution (law of Gauss). Under these conditions the allowance for the locking link is found by the formula

$$s_1 = \sqrt{\sum s_{1i}^2}.$$

For the example examined earlier (see Fig. 22.1b)

$$s_1 = \sqrt{0,3^2 + 0,1^2 + 0,06^2 + 0,2^2 + 0,2^2 + 0,06^2} = 0,432 \text{ mm},$$

i.e., more than twice less than in calculation according to the first method.

Practice shows that the result of the calculation according to the second method gives good coincidence with the activity in not all cases.

The best coincidence of the calculation with the actuality is given by the third method.

3. The combined method consists in the fact that algebraically summarized are middles of fields of allowances (where the largest quantity of parts is grouped) and quadratically summarized are magnitudes of dispersion of allowances. The formula for the calculation of the allowance of the locking link has the form:

$$s_1 = \sum a_i \pm \sqrt{\sum a_i^2}$$

where a_i - center of bunching (usually half of the field of allowance).

For the subassembly depicted on Fig. 22.1b,

$$\delta_1 = 0,46 \pm \sqrt{0,15^2 + 0,05^2 + 0,03^2 + 0,1^2 + 0,1^2 + 0,03^2} = \\ = 0,46 \pm 0,21 \text{ mm.}$$

§ 2. Dynamic Balancing

The balancing of rotating parts and subassemblies is conducted for the purpose of the balancing of masses. The revolving unbalanced masses are sources of vibration of machines. The essence of the appearance of vibrations was examined by us earlier in § 4 of Chapter 13.

Static and dynamic balancing are distinguished. The process of static balancing, examined in § 4 of Chapter 13, has considerable errors in the measurement of unbalance. Furthermore, statically balanced parts and subassemblies can with rotation appear unbalanced due to the appearance of the moment of centrifugal forces.

Dynamic balancing is conducted under conditions close to real conditions of operation of the revolving part of subassembly, in consequence of which it is more accurate and reveals instabilities which cannot be determined by static balancing.

Let us examine the behavior of the unbalanced rotor shown in Fig. 22.2. Both disks fitted on the shaft have unbalance. The magnitude of the unnecessary mass of the left disk is designated m_1 and that of the right - m_2 . If the moment of unnecessary mass of the left disk $m_1 r_1$ will be equal to the moment of unnecessary mass of the right - $m_2 r_2$ (see Fig. 22.2 on the right), then the unbalanced nature of such a rotor cannot be revealed by static balancing, since in a state of rest the rotor is balanced. With rotation of such a rotor, masses unbalanced in the disks will cause centrifugal forces P_1 and P_2 located in various planes. As a result of the action of these forces there will appear a moment trying to turn the axis of the shaft, i.e., the rotor will appear unbalanced.

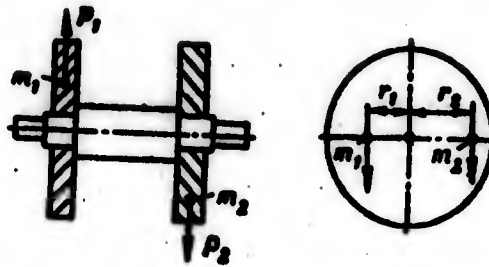

Fig. 22.2. Dynamically unbalanced rotor.

Exposure of the dynamic instability is conducted on special balancing machines. The principle of dynamic balancing consists in the following.

The rotor subject to balancing is set on elastic supports and rotated. Under the action of unbalanced masses supports of the rotor will start to oscillate. The magnitude of oscillations is proportional to the magnitude of instability. In measuring the oscillations, we determine the unbalance. The design of the balancing machines is fulfilled depending upon the weight of the balanced rotors and the accuracy of the balancing. Figure 22.3 shows a diagram of the balancing machine in which the measurement of the magnitude of instability is fulfilled with the help of electromagnetic transducers. The rotor 4 tested is set in elastic supports 3 and 5, which can oscillate in a horizontal plane. The supports are united with coils of the induction transducers.

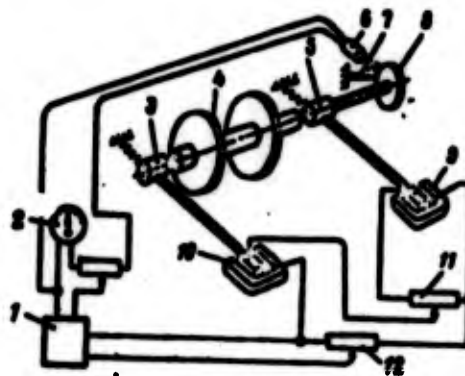

Fig. 22.3. Diagram of a machine for dynamic balancing: 1 - amplifier; 2 - recording instrument; 3, 5 - elastic supports; 4 - balanced rotor; 6 - stroboscopic tube; 7 - indicator; 8 - graduated disk; 9, 10 - induction transducers; 11, 12 - potentiometers.

For a test the rotor is rotated (the drive on the diagram is not shown) at a speed of 450-650 r/min. If the rotor is unbalanced, it will start to oscillate, and together with it coils in the magnetic field of induction transducers 9, 10 will oscillate which will cause pulsating currents in the electric circuit.

The voltage of the current is proportional to the amplitude of the oscillations. The voltage is measured by instrument 2 connected to the circuit through amplifier 1. By connecting one or another transducer, it is possible to measure the magnitude of instability.

To determine the position of the unbalanced according to mass the angle of turn, we use a graduated disk 8, which revolves together with the rotor, and a stroboscopic tube 6, which gives a flash at the time of passage of the unbalanced mass through the plane of location of the transducers. Due to the fact that the eye of a person has inertia, i.e., delays the received stimulation by a certain time (fraction of a second), the alternating images of the disk in the light of the flashing tube appear coalescent, and the disk looks as if it were stopped. The angle of rotation of the disk is read with the help of indicator 7, which is stationarily secured. Machines operating on this scheme possess a high accuracy of balancing. The minimum measured unbalances are 2-3 gf·cm.

A deficiency of such machines consists in the fact that the oscillation of the supports in the process of balancing is reflected on the character of rotation of the rotor. Due to this condition, operations of the tested rotor will be distorted as compared to conditions of its operation in real conditions when the supports will be stationary.

This deficiency is eliminated in balancing machines with fixed supports. On these machines the effect of unbalance of the rotor on supports is measured with the help of piezoelectric transducers, which are built into the fixed supports. The magnitude of the

obtained electrical pulse of the transducer is proportional to the mechanical effect of the rotor. In such a way almost full correspondence of conditions of the test is attained by real conditions of operation of the rotor.

C H A P T E R 23

ASSEMBLY OF SUBASSEMBLIES AND UNITS OF LIQUID PROPELLANT ROCKET ENGINES

§ 1. Assembly of Control Valves

Control valves in most cases consist of comparatively small parts united by an aluminum or steel casing, which is the base part in assembly.

Subassemblies making up the valve are gathered separately, and then general assembly into the casing is carried out. Division into subassemblies and the technology of assembly depend on the design of the valve. However, there are many general characteristic procedures used in the assembly of different valves. To understand the essence of these characteristic procedures let us examine the technological process of assembly of the pressure reducer [2] shown in Fig. 23.1. The reduction valve is intended for lowering the pressure of the gas and maintaining this pressure constant at the outlet of the reduction valve independently of the change in inlet pressure. It consists of the following main centers: casing A, valve B of high pressure, inlet filter C low-pressure chamber D with a regulating device, safety valve E and flow cock F. All these subassemblies are preliminarily collected separately, and then they are installed into the casing.

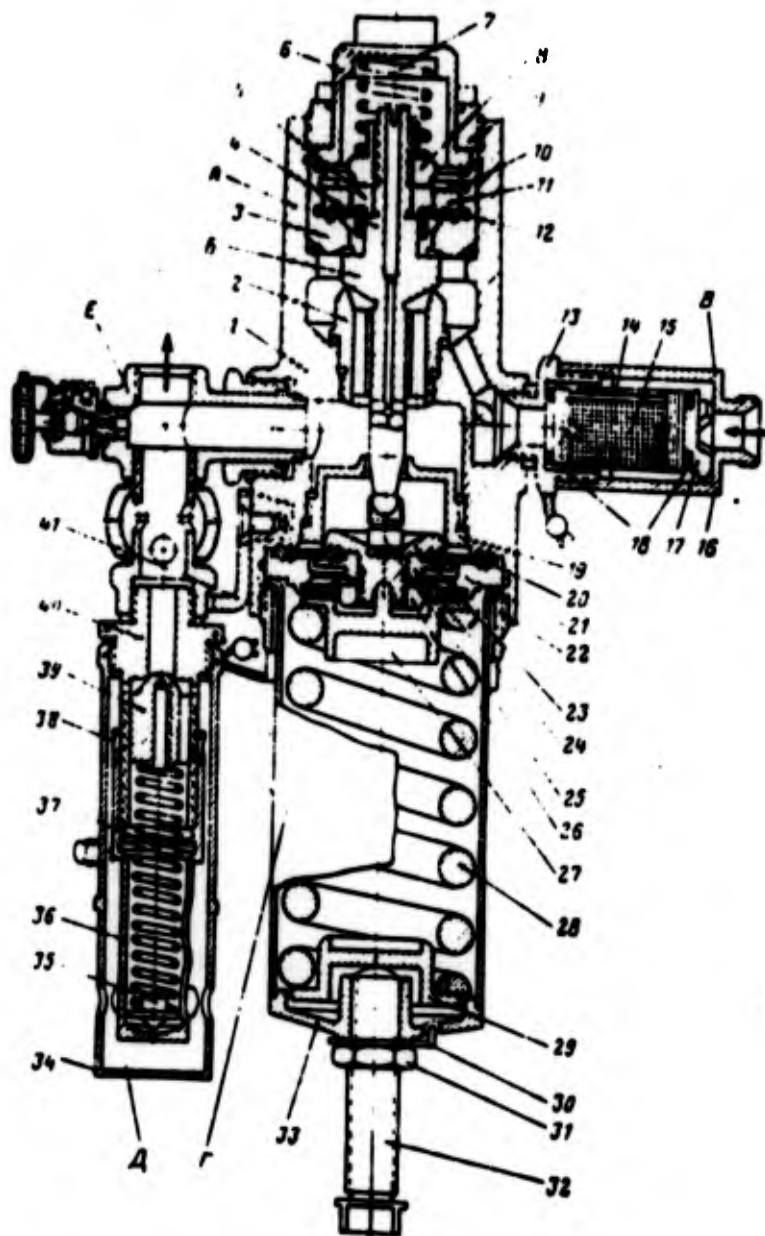

Fig. 23.1. Pressure reducer: A - body; B - valve; B - filter; A - low-pressure chamber; A - safety valve; E - flow cock; 1 - casing; 2 - valve seat; 3 - casing of membrane; 4 - valve; 5 - unloading washer; 6 - jacket; 7 - spring; 8, 9 - nuts; 10 - locking ring; 11 - thrust ring; 12 - membrane; 13 - pipe connection; 14 - frame; 15 - grid; 16 - casing of filter; 17 - plate; 18 - packing; 19 - guide bushing; 20 - membrane; 21 - casing of membrane; 22 - nut; 23 - thrust bearing; 24 - washer; 25 - compensator; 26 - nut; 27 - plate; 28 - spring; 29 - plate; 30 - lock washer; 31 - nut; 32 - regulating screw; 33 - housing; 34 - jacket; 35 - thrust bearing; 36 - regulating jacket; 37 - spring; 38 - nut; 39 - valve; 40 - casing of valve; 41 - collar.

Assembly of the filter. For the base part there is taken the pipe connection 13, into which the following are consecutively installed: packing 18, grid 15 with frame 14 (preliminarily united), second packing 18 and plate 17. Then the casing 16 is carefully screwed on. After assembly the filter is tested for airtightness and passability of gas. In the test for airtightness, on the pipe connection of the casing 16 an industrial plug is installed, and through the hole of the pipe connection 13 air under pressure is fed. The magnitude of the pressure is determined by the TU.

Control of the airtightness is fulfilled by means of smearing the joint with a soap emulsion or other method. In the continuity test the filter is scavenged with air on a special test stand. At the inlet and outlet of the filter tubes of the differential manometer are joined, according to readings of which the magnitude of internal drag of the filter is determined. After the tests at the inlet and outlet of the filter plugs are installed, and the joint of the pipe connection 13 and casing 16 is locked.

Figure 23.1 shows locking by a wire, on the ends of which a seal is set.

Assembly of safety valve. Taken as the base part is the casing 40, onto which locking nut 38 is preliminarily screwed. Into the cavity of casing 40 valve 39 and spring 37 are set. The internal diameter of the spring should be somewhat larger than the diameter of the projection of the valve 39. The valve should freely move in the casing. Then from above the spring a thrust bearing 35 is installed and the regulating jacket is carefully screwed onto the thread of the casing of the valve. After assembly adjustment and test of the valve for airtightness of fitting of valve 39 onto the seat of the casing 40 and also for operation of the valve at the assigned pressure are conducted. For this purpose the valve is screwed into the socket of the special stand, and the necessary air pressure is given. Regulation of the pressure of operation is carried out by the screwing or unscrewing of the jacket 36. After the valve is regulated the jacket 36 is stopped by a nut 38. The

airtightness of the fit of the valve is checked by means of the measurement of the quantity of air flowing through the valve. For this purpose the valve, united by a flexible hose with the test stand, can be put into water, and according to the quantity of bubbles per minute we can determine the magnitude of unhermeticity. After this operation valve it is necessary to blow with compressed air and dry the valve. Other methods of the control of airtightness without submersion into water are also used. The regulated and tested safety valve is closed by a protective jacket 34, which is locked and is sealed.

Assembly of the reduction valve. Taken as the base element of the assembly is casing 1, into which is preliminarily screwed seat 2 and guide bushing 19. At first we collect subassembly B, i.e., the valve of high pressure. Into casing 3 of the membrane, membrane 12 is set, it is pressed by thrust ring 11 and is stopped by a locking slotted spring ring 10, which enters into the annular groove on the internal surface of the casing 3. Then the unloading washer 5 is installed, and all these parts are placed on the shank of the rod of valve 4 and tightened by nut 8. The collected subassembly B is set into the casing of the reduction valve, on nut 8 spring 7 is placed, and it is covered by jacket 6 and tightened by nut 9. With the installation of subassembly B one checks the freedom of movement of the valve rod: prior to installation of spring 7 and jacket 6 in a vertical position the rod should move in the guide bushing of seat 2 freely under the action of its own weight. After the tightening of nut 9 one checks the evenness of movement of the rod by depressing on the spheric head of the rod from the opposite side (from the side of the compensator 25). If there are indications of jamming, then disassemble the subassembly and replace the rod.

The assembly of subassembly Г is fulfilled in such a sequence. Put onto thrust bearing 23 is membrane 20 with washer 24, the casing 21 is installed, then a concave thin washer, and it is tightened by nut 26. Then into housing 33 the lower plate 29, spring 28 and upper plate 27 are inserted. From above subassembly of the thrust

bearing and compensator 25 are installed. After that the housing 33 is connected to the casing of the valve and is secured by a sleeve nut 22. In the base of housing 33 a regulating screw 32 with locking nut 31 and washer 30 is screwed.

After assembly of subassemblies Б and Г to the casing of the reduction valve preliminarily collected filter В, outlet cock Е and safety valve А are connected.

The tuning of the reduction valve and check of efficiency are carried out on a special test stand with measurement of inlet and outlet pressures of the reduction valve and its carrying capacity. Airtightness of the fit of the valve on the seat and airtightness of connections are checked also. The design of test stands used and methods of tests of reduction valves are described in special literature.

§ 2. Assembly of Pumps of the Turbopump Unit

Pumps of the turbopump unit are assembled three times: the first assembly is produced for testing the pump for productivity; the second - for tests of operation of the pumps jointly with the turbine; the third assembly - final.

Let us consider the technological process of the assembly of pumps in the example of the fuel pump shown on Fig. 23.2. First assembly: for the base part there is taken casing 7, which is secured on a special assembly cart in such a manner so that the pins of bracing of the turbine are turned upwards. Inserted into the body is shaft 4 with bearing 3 preliminarily pressed on it and with fitted packing collars. Then packing element 2 is installed, and cover 1 is screwed on. For further assembly casing together with the turning part of the device turn 180° in such a manner so that the second end of the shaft appears to be on top. On slits of the shaft 4 impeller 8 is installed and it is secured by nut 10. With installation of the impeller it is necessary to make sure that the mark on the slit of the shaft coincides with the corresponding slit groove in

the bushing of the impeller (marks are applied earlier with the selection of the fit of slits and balancing of the impeller together with the shaft). Then the cover 9 and regulator of the number of revolutions 13 are screwed on. Preliminarily installed into cover 9 are sealing rings 11, and bearing 12 is pressed in. After assembly the dimension L, play of the surface Δ and evenness of rotation in the bearings are checked.

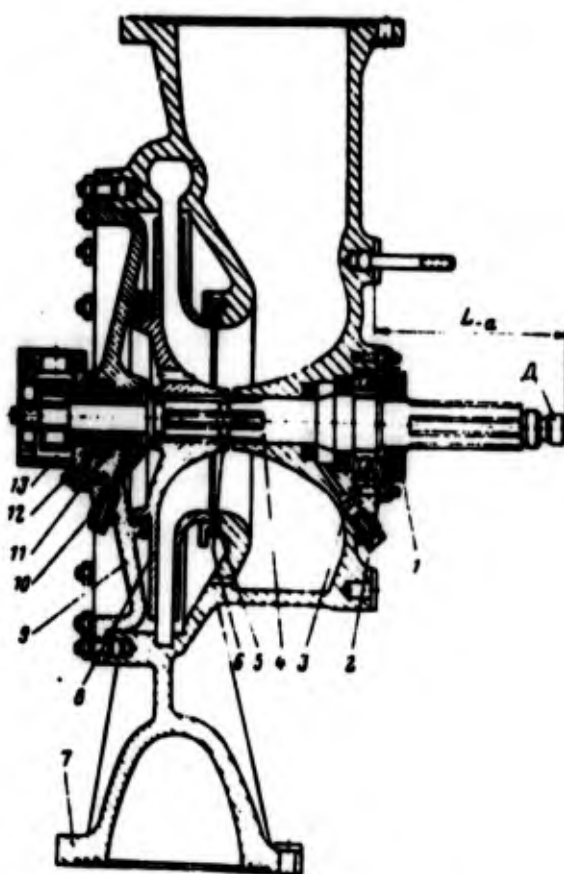

Fig. 23.2. Fuel pump: 1, 9 - covers; 2 - sealing bushing; 3 - ball bearing; 4 - pump spindle; 5 - sealing ring; 6 - regulating ring; 7 - casing of pump; 8 - impeller; 10 - nut; 11 - sealing ring; 12 - ball bearing; 13 - regulator of number of revolutions of the turbopump unit.

To check the airtightness, on the branch pipes of the pump industrial plugs are installed, and inside the assigned air pressure is created, and line feeding the air is covered. The degree of unhermeticity is determined according to the decrease in pressure for the assigned time interval.

Unhermeticity of the external joint is determined with the help of soap emulsion or by another method.

The test for productivity is conducted by means of the circulation of water on a special test stand with rotation of the impeller from an electric motor with an assigned number of revolutions. At the inlet into pump there is created rated pressure, and at the outlet boost pressure and flow rate of water are measured. According to the results of the tests, a characteristic of the pump is plotted. If the characteristic does not correspond to the TU, then the pump is disassembled and the external diameter of impeller is turned. The magnitude of machining (decrease in diameter) is determined by calculation. After machining balancing of the impeller with the shaft is conducted, and again the pump is assembled for tests for productivity. If the characteristic of the pump corresponds to the TU, then the pump is disassembled, the parts are dried, defects are looked for and it is directed for a second assembly.

The second assembly is conducted in the same sequence as that of the first; however, the industrial parts allowed in the first assembly (fastening and certain others), are replaced by working parts. The assembled pump is directed for general assembly of the turbopump unit, which then passes test firings on the engine.

After the test firings all subassemblies of the turbopump unit, including the pumps, are disassembled, the parts are neutralized, washed, dried and under checking for defects.

The damaged parts and also parts of single-time application (packings, washers, splint pins) are replaced by new ones.

Third, final, assembly, including pneumatic tests, is conducted in the same sequence as the first; however, in this case, special thoroughness of the fulfillment of operations is observed, since subsequently the pump is not tested and is sent for the final assembly of the turbopump unit.

§ 3. Assembly of the Turbopump Unit

The general assembly of the turbopump unit (TNA) consists of three stages:

- 1) check of the coaxiality of the casings;
- 2) first assembly for hot tests;
- 3) final assembly.

The necessity of checking the coaxiality of the casings is brought about by the fact that main units entering into turbopump unit - fuel pump, oxidizer pump and turbine - have parts jointly revolving at high speed: two impellers and a turbine disk. The axes of rotation of these parts must have high accuracy. The relative position of supports of shafts on which there is planted the impeller and turbine disk is determined by seats under bearings located in various casings. Consequently, the technological process of the manufacture of casings and their joint assembly should ensure good coaxiality of fitting bearing seats.

For this purpose on joint surfaces of the casing annular recesses or special grooves located criss-cross are provided; the axis of these grooves cross in the center of the borings under the bearings. Methods of safeguarding the coaxiality of axes of grooves and bearing seats were examined in Chapter 16, "Treatment of Casing Parts and Subassemblies." With assembly of the turbopump unit, into the cross-like grooves of special precision keys 4 the casings are set, which mutually orient the combinable subassemblies (Fig. 23.3). By this the coaxiality of borings under bearings located in various casings is ensured.

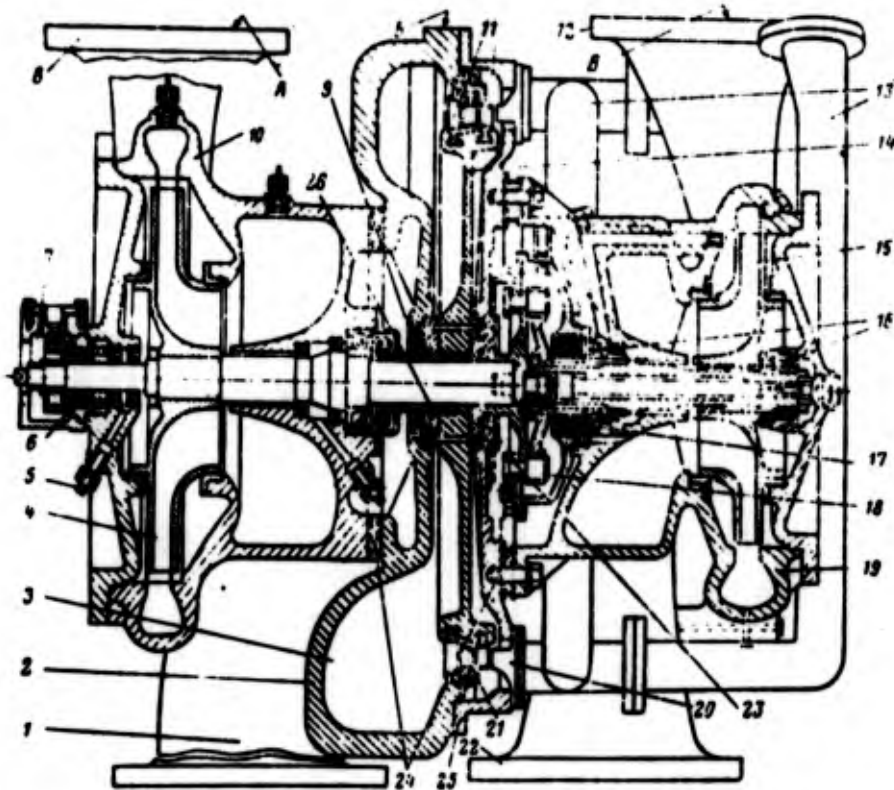

Fig. 23.4. Turbopump unit: 1 - inlet volute of the fuel pump; 2 - casing of the turbine; 3 - exhaust collector; 4 - impeller of fuel pump; 5 - pipe connection; 6 - ball bearing; 7 - regulator of revolutions of the turbopump unit; 8 - branch pipe of the pump; 9 - packing of the turbine; 10 - casing of fuel pump; 11 - turbine blade; 12 - branch pipe of oxidizer pump; 13 - feed of vapor gas; 14 - turbine disk; 15 - impeller of oxidizer pump; 16 - plain bearings; 17 - packing; 18 - elastic coupling; 19 - casing of oxidizer pump; 20 - nozzle of the turbine; 21 - blades of guide vane; 22 - inlet volute of oxidizer pump; 23 - coupling disk; 24 - fixing keys; 25 - cover of the turbine; 26 - bushing; A, B - pumps; 5 - turbine.

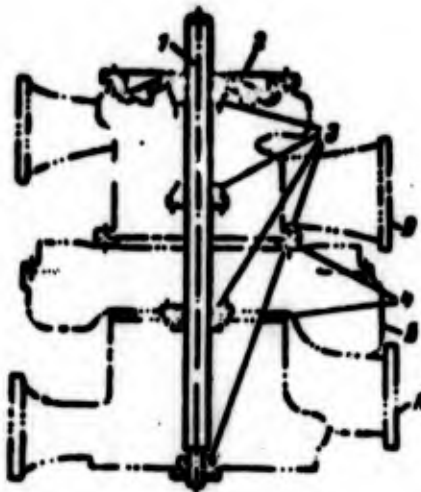

Fig. 23.3. Diagram of checking the coaxiality of units of the turbopump unit: A - fuel pump; 5 - turbine; B - oxidizer pump; 1 - plunger; 2 - industrial cover; 3 - industrial bushings; 4 - key.

To check the attained coaxiality, installed into seats of the bearings are industrial bushings 3, which have in the center precision holes of identical diameter. With respect to external diameter the bushings will be selected in such a manner so that they are set into the bearing seats with a small clearance (not more than 0.01 mm). Into holes of the bushings there is inserted a precision smooth, plunger lubricated by machine oil (clearance between the plunger and bushings is not more than 0.01 mm) If the plunger freely under its own weight passes through all the bushings, the coaxiality is considered to be satisfactory. There are also special mechanical and optical-mechanical instruments for checking the coaxiality of casings of the turbopump unit.

If the coaxiality is unsatisfactory, then replacement of keys 4 or the fitting of them in place is conducted. If instead of cross-like grooves, on the casings for their centering annular recesses are provided, then the accuracy of the obtainable coaxiality depends on allowances for the manufacture of these recesses. Orientation of the casings by the angle of turn is attained by the installation of pins or keys.

First assembly of the turbopump unit. The technological process of the general assembly of the turbopump unit depends on the design of the pumps, turbine and other subassemblies and also on methods of their connection and mutual centering. Let us examine the process of assembly of the simple turbopump unit depicted on Fig. 23.4. Taken as the base element is the fuel pump, which is installed on the assembly cart by the protruding end of the shaft upwards. Installed on keys 24 is the casing 2 turbine together with packing 9, and it is secured with pins. Tightening of the pins is conducted in an assigned sequence. Deviation from the order of tightening can lead to a disturbance of the coaxiality of the casings. Mounted on the protruding end of the pump spindle is disk 14 of the turbine together with blades 11 and bushings 26. Between blades of the first and second stages of the turbine four sectors of the guide vane with blades 21 are installed. The sectors are fastened to the casing of the turbine. Here clearances between rotor and stator blades are checked.

Then the cover 25 together with the packing and disk 23 of the clutch is installed. The cover 25 of the turbine is braced to the casing 2, and the disk 23 is braced to the pump spindle with the help of a special nut. After that the oxidizer pump is installed and fastened. Assembly is finished with installation of pipes 13 of the feed of working gas of the turbine.

After assembly the turbopump unit is tested for airtightness and is sent for general assembly of the engine for test firings. Test firings are conducted on a special test stand under conditions close to operating conditions.

After test firings of the turbopump unit is disassembled, all parts are washed, dried and undergo a defect check. All damaged and industrial parts, and also parts of single-time application are replaced, after which they are sent for final assembly of the turbopump unit.

The final (or commodity) assembly of the turbopump unit is conducted in the same sequence as that of the first assembly but more thoroughly.

The examined design of the turbopump unit is the simplest. At present more complex turbopump units are used. In particular, the design of the turbopump unit includes prepumps of the screw or other types for increasing the pressure of the liquid at the input for the purpose of preventing cavitation pumps for feeding liquid into the hydraulic systems of control of the thrust vector and others.

The technological process of the assembly of such a turbopump unit is more complicated. However, basic principles of the assembly are the same as those with the assembly of a simple turbopump unit.

In certain designs for the fuel feed axial pumps are used. Assembly of the turbopump unit with axial pumps considerably differs from that assembly of the turbopump unit examined above with centrifugal pumps and is not examined here.

CHAPTER 24

GENERAL ASSEMBLY OF LIQUID PROPELLANT ROCKET ENGINES

The general assembly of a liquid propellant rocket engine is conducted in special well-equipped locations with the observance of high cleanness and efficiency of production.

All operations of the assembly are strictly fulfilled according to the thoroughly developed technological process with appropriate technical control. Each engine passes two assemblies: first - industrial and second - commodity.

The first assembly is divided into the following basic stages:

1. Assembly of industrial groups (conducted in parallel with the general assembly).
2. Connection of basic units and groups.
3. Installation of control valves.
4. Installation of pipelines.
5. Installation of electric equipment.
6. Electropneumatic tests.
7. Test firings.
8. Dissection and inspection of characteristic subassemblies.
9. Disassembling, neutralization, control inspection of subassemblies and parts, washing, drying.
10. Check for defects.

The specific content of the assembly operations is determined by the design of the engine and its dimensions. In the presence of the power frame the basic units are braced to its elements. In engines of frameless design, taken as the base element of assembly is the combustion chamber. The connection of subassemblies and units is fulfilled with the help of bolts or welding.

Electropneumatic tests, and test firings are conducted on special test stands according to a program developed in reference to conditions of operation of a given engine.

After the test firings before the general disassembling, dissection and inspection of the characteristic subassemblies or units are conducted, the state of which reflects the quality of operation of certain parts of the engine. For example, the state of the oil filters or settling tanks shows the operation of the friction parts and criteria of their destruction; the abnormal carbon formation indicates the disturbance of the process of combustion; the colors of the iridescent tarnish are the result of overheating of the parts, etc.

Then disassembling of the engine and neutralization of the parts and subassemblies are conducted for the purpose of decontaminating residues of aggressive liquids and gases. Methods of neutralization are selected depending upon the components of fuel and composition of combustion products used in the test. The neutralized parts are directed for washing and drying.

Before washing control inspection of the parts and subassemblies is carried out for the purpose of revealing those defects which cannot be revealed after washing (presence of carbon, traces of oxidation, sticking of packing elements).

The washed and dried parts are subjected to thorough inspection and defect checking with measurement of the characteristic dimensions. In necessary cases X-ray, ultrasonic or other method of control of quality of the material and also welded and brazed connections are used.

Data of the inspection and control are entered into special documentation, which is then processed. On the basis of statistical data, characteristic defects of the operation of the engine are revealed. Knowledge of the characteristic defects reduces the time of control, since on these parts the attention of controllers is concentrated, and also the quality of control is increased. Furthermore, on the basis of the analysis of defective records measures for the improvement of the design or technology of manufacture of parts and subassemblies are taken.

With disassembling, washing, drying and other operations, after disassembling measures for the preservation of the completeness of parts are taken so that the parts and subassemblies of the disassembled engine make up the same engine in the second assembly.

The second commodity assembly is conducted according to the same technological process as that of the first assembly prior to the stage of electropneumatic tests inclusively but more thoroughly.

Before assembly subassemblies and parts proceeding for commodity assembly are completed. All defective parts revealed after technological tests in the first assembly and also parts of a single-time application (packings, washers, splint pins) are replaced by new ones. On appropriate parts and subassemblies final protective coatings are applied. In the process of assembly a post-operation technical control is conducted.

With assembly one is guided by assembly drawings of the engine, technical conditions for assembly and charts of the technological process of the assembly.

Figure 24.1 gives a general view of the American hydrogen-oxygen engine J-2.

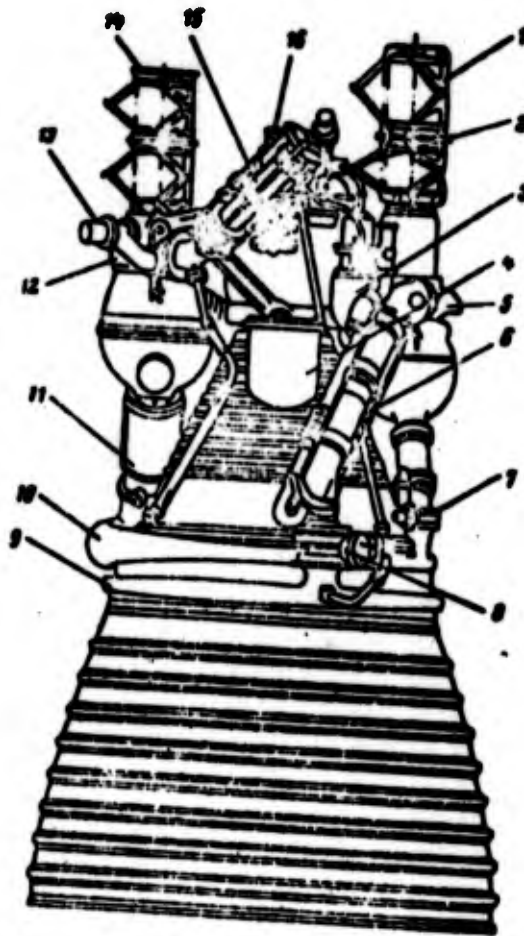

Fig. 24.1. Engine J-2: 1 - feed main fuel line; 2 - main oxidizer valve; 3 - gas generator; 4 - electrical control unit; 5 - fuel pump; 6 - main fuel line after the pump; 7 - oxidizer bypass valve of turbine; 8 - main fuel valve; 9 - fuel collector; 10 - exhaust collector; 11 - heat exchangers; 12 - oxidizer pump; 13 - throttle to change ratio of fuel components; 14 - feed main oxidizer line; 15 - main oxidizer line after the pump; 16 - Cardan subassembly suspension.

Basic characteristics of this engine

Length.....	3380 mm
Diameter.....	2046 mm
Thrust (at rated altitude).....	90,800 kgf
Nominal duration of the operation.....	500 s
Consumption:	
oxidizer.....	178 kg/s
fuel.....	35.4 kg/s
Nominal pressure in the chamber.....	44.4 atm(abs.)
Dry weight.....	1580 kg
Nozzle expansion ratio.....	27.5

The combustion chamber (KS) is made from tubes of stainless steel with the thickness of the walls of 0.3 mm, which are united by brazing. The engine is secured to the rocket by a Cardan suspension 16, which allows deflecting the axis of the chamber for controlling the direction of the thrust vector. The support of the Cardan suspension is made adjustable to achieve coaxiality of the engine and rocket.

The engine has two turbopump units for feeding components of fuel: turbopump unit of the oxidizer with a single-stage pump 12 and turbopump unit of the combustible with a seven-step pump 5. Exhaust gases from the turbopump unit are directed into the nozzle part of the KS through the collector 10. On the fuel and oxidizer lines directly before the input into the chamber the main oxidizer valve 2 and main fuel valve 8.

As the base element with assembly of this engine one should take the combustion chamber, to which all subassemblies and units of the engine are secured. Turbopump units are fastened in two places: to the cylindrical part of the KS and to the exhaust collector 10 through the heat exchanger 11 and bypass valve 7. The position of the axes of the turbopump unit with respect to the axis of the engine is determined by rigid connections. These connections

determine the position of the axes of lines 1 and 14 for feeding hydrogen and oxygen. Since the engine upon operation rocks with respect to the center of the spherical support of the Cardan suspension subassembly 16, then on lines 1 and 14 flexible pipelines are installed. The latter are located in height in such a manner so that the middle of the sections of the pipelines are at the same altitude with the center of the spherical support. In this way the minimum value of the resistant moment to the rocking of the chamber and equality of moments with deflection to one and the other side are attained. The main oxidizer valve 2 and main fuel valve 8 are fastened directly to collectors of the chamber. The main fuel line 6 from the pump 5 up to the main valve 8 is short and is braced to the exhaust duct of the pump and flange of valve 8. Installation of remaining valves and pipelines does not require explanation.

Figure 24.2 shows the propulsion system of the third stage of the rocket "Titan" 3. It consists of two combustion chambers 3 mounted on power frame 5.

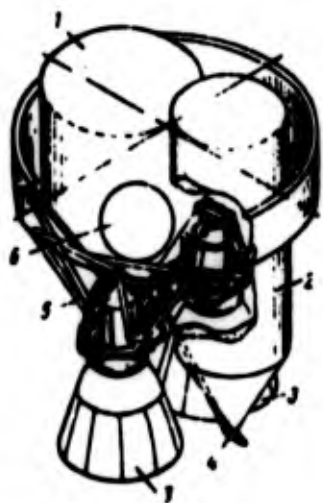

Fig. 24.2. Propulsion system of the third stage of the rocket "Titan" 3: 1 - oxidizer; 2 - fuel tank; 3 - combustion chamber; 4 - main line of feed fuel; 5 - power frame; 6 - cylinder with helium.

The combustion chambers have ablative shielding of the walls from the effect of the high temperature of gases. Used as ablative shielding is a fiber of Refrasil with impregnation by phenolic resin. The stability of the ablative shielding is not less than 500 s (with control test firings the stability is more than 1000 s). The nozzle

part of the KS is cooled only by thermal radiation. Its upper part (where there are high temperatures of gases) is made from columbium and the lower (less heat proof part) from a cheaper material - titanium. The injector head is connected with the chamber by means of a bolt connection. On the fire base of the injector head there are the partitions stabilizing the process of combustion, which are cooled a fuel channel.

The feed of fuel components is carried out by the method of displacement from the tanks with the help of helium proceeding from the cylinder 6. The propulsion system is intended for flight in space with a duration of about 6.5 hours with the possibility of repeated startings. Therefore, all heated parts (chamber, injector head, pipelines) have good thermal insulation for preventing freezing of the fuel during power-off flight under conditions of intense cooling of the construction.

The thermal insulation layer has an external shell of glass cloth with impregnation by epoxy resin for increasing the strength.

Basic Characteristics of the Propulsion System

Length of engine.....	2050 mm
Diameter of exhaust section of the nozzle...	1210 mm
Thrust (in a vacuum).....	2 × 3600 kgf
Nominal duration of operation.....	500 s
Pressure in the combustion chamber.....	7 [atm(abs.)]
Nozzle expansion ratio.....	40
Weight of primed engine.....	2 × 103 kg

The peculiarity of technological process of assembly of a given engine and other engines of similar type is determined by the presence of the power frame. The fastening of combustion chambers to the frame should be carried out in such a way so that the axes of the KS are perpendicular to the joint plane or inclined toward it at an assigned angle. To execute this condition, a special device,

which mutually orients the axis of the KS and joint plane of the frame is required. For the base element of the assembly there can be taken the frame or combustion chamber, depending upon the convenience of assembly and design of the device. After fastening the KS to the frame valves are installed, and pipelines are assembled by the usual methods.

After test firings residues of ablative shielding are removed and a new layer is applied. A detachable injector head creates the convenience of inspection of injectors, base and walls of the chamber and also simplifies the technology of applying the ablative shielding.

BIBLIOGRAPHY

1. Abramov A. M., Zelikov I. L., Ikzon M. F., Konarev A. B., Mityashkin D. Z., Nikol'skiy L. A., Pronina Ye. M., Romanov K. F., Talanova G. A., Proizvodstvo gazoturbinnnykh dvigateley, Spravochnoye posobiye (Production of gas turbine engines Reference manual) "Mashinostroyeniye", 1966.
2. Belikov V. N., Nikitin A. N., Sborka aviataionnykh dvigateley (Assembly of aircraft engines) "Mashinostroyeniye", 1964.
3. Gubin A. I., Payka nerzhaveyushchikh staley i zharoprochnykh splavov (Brazing of stainless steels and heat-resistant alloys) "Mashinostroyeniye", 1964.
4. Daniyelyan A. M., Bobrik P. I., Gurevich Ya. L., Egorov I. S., Obrabotka rezaniyem zharoprochnykh splavov i tugoplavkikh metallov (Treatment by cutting of heat-resistant alloys and refractory metals) "Mashinostroyeniye", 1965.
5. Evstigneyev M. I., Morozov I. A., Podzey A. V., Sulima A. M., Tsukanov I. S., Izgotovleniye osnovnykh detaley i uzlov aviadvigateley (Manufacture of basic parts and subassemblies of aircraft engines) "Mashinostroyeniye", 1964.
6. Esenberlin R. S., Payka metallov v pechakh s gazovoy sredoy (Brazing of metals in furnaces with a gaseous environment) Mashgiz, 1962.
7. Minkov M. A., Tekhnologiya izgotovleniya rlybokikh tochnykh otverstiy (Technology of the manufacture of deep precision holes) "Mashinostroyeniye", 1965.
8. Nikolayev G. A., Ol'shanskiy N. A., Novyye metody svarki metallov i plastmass (New methods of the welding of metals and plastics) "Mashinostroyeniye", 1966.
9. Fominykh V. P., Oborudovaniye i tekhnologiya dugovoy svarki (Equipment and technology of arc welding) "Mashinostroyeniye", 1966.

UNCLASSIFIED
Security Classification

DOCUMENT CONTROL DATA - R & D

(Security classification of title, body of abstract and indexing annotation must be entered when the overall report is classified)

ORIGINATING ACTIVITY (Corporate author) Foreign Technology Division Air Force Systems Command U. S. Air Force	20. REPORT SECURITY CLASSIFICATION UNCLASSIFIED
	28. GROUP

REPORT TITLE
PRINCIPLES OF THE PRODUCTION OF LIQUID-PROPELLANT ROCKET ENGINES

3. DESCRIPTIVE NOTES (Type of report and inclusive dates)
Translation

1. AUTHOR(S) (First name, middle initial, last name)
Gorev, I. I.

REPORT DATE 1969	70. TOTAL NO. OF PAGES 398	75. NO. OF REFS 9
---------------------	-------------------------------	----------------------

50. CONTRACT OR GRANT NO.	55. ORIGINATOR'S REPORT NUMBER(S) FTD-MT-24-39-70
6. PROJECT NO. 6040104	58. OTHER REPORT NO(S) (Any other numbers that may be assigned this report)
c. DIA Task Nos. T65-04-18A, d. T65-01-83A, T65-01-82	

10. DISTRIBUTION STATEMENT
Distribution of this document is unlimited. It may be released to the Clearinghouse, Department of Commerce, for sale to the general public.

11. SUPPLEMENTARY NOTES	12. SPONSORING MILITARY ACTIVITY Foreign Technology Division Wright Patterson AFB, Ohio
-------------------------	---

13. ABSTRACT
The book examines the technological processes of the manufacture of the most characteristic parts, subassemblies and units of liquid-propellant rocket engines. These include the combustion chamber, turbopump unit, power frames, valves, pipelines and also the technology of unit and general assembly. Contemporary methods of the obtaining of accurate thin-walled large parts, the technology of their machining and the adaptation for the fastening of parts having little rigidity are discussed. Methods are examined for connecting thin-walled large parts by welding and brazing with the use of high-temperature solders as well as the design of special devices for welding and soldering in inert gases and a vacuum. Characteristic defects of welding and soldering and methods of detecting them are given. The technology of the manufacture of injectors, injector heads and the assembly of combustion chambers are examined. Methods of the manufacture of thin-walled pipelines of complex configuration from sheet metal, the technology of the fitting nipples, formation of corrugations, and methods of the assembly of pipelines are discussed. Methods of static and dynamic balancing of parts and subassemblies of the turbopump unit are examined. The book also goes into methods of assembly, tools and equipment of assembly workshops, methods of preparation of parts for assembly, the applying of protective coatings. Orig. art. has: 175 figures.

DD FORM 1 NOV 68 1473

UNCLASSIFIED
Security Classification

14 KEY WORDS	LINK A		LINK B		LINK C	
	ROLE	WT	ROLE	WT	ROLE	WT
Liquid Propellant Rocket Engine Combustion Chamber Turbopump Rocket Engine Thrust Pipeline						