

AD708449

**DASA-2440**  
**KN-770-70-35**

**THE THEORY AND CAPABILITIES OF  
MAGNETICALLY DRIVEN FLYERS**

BY  
**THOMAS F. V. MEAGHER**  
**DAVID C. WILLIAMS**

**JUNE 1970**

THIS DOCUMENT HAS BEEN APPROVED FOR PUBLIC RELEASE AND SALE;  
ITS DISTRIBUTION IS UNLIMITED.

**DEFENSE ATOMIC SUPPORT AGENCY**  
**WASHINGTON, D. C. 20301**

**PREPARED BY**  
**KAMAN NUCLEAR**  
**1700 GARDEN OF THE GODS ROAD**  
**COLORADO SPRINGS, COLORADO 80907**  
**CONTRACT NO. DASA-01-68-C-0084**

Reproduced by the  
CLEARINGHOUSE  
for Federal Scientific & Technical  
Information Springfield Va. 22151

D D C  
RECEIVED  
JUN 10 1970  
C

66

ACQUISITION FOR		
CFSTI	WHITE SECTION	<input checked="" type="checkbox"/>
DOC	COFF SECTION	<input type="checkbox"/>
UNANNOUNCED		<input type="checkbox"/>
JUSTIFICATION		
BY		
DISTRIBUTION AVAILABILITY		
DIST.	AVAIL.	SEL.
/		

**DESTROY THIS REPORT WHEN IT  
IS NO LONGER NEEDED. DO NOT  
RETURN TO SENDER.**

**DASA-2440**

**KN-770-70-35**

**THE THEORY AND CAPABILITIES OF  
MAGNETICALLY DRIVEN FLYERS**

**This work was supported by the  
Defense Atomic Support Agency  
under NWER Subtask AC 301**

**by**

**Thomas F.V. Meagher**

**David C. Williams**

**June 1970**

**This document has been approved  
for public release and sale; its  
distribution is unlimited.**

**DEFENSE ATOMIC SUPPORT AGENCY**

**WASHINGTON, D.C. 20301**

**Prepared by**

**Kaman Nuclear**

**1700 Garden of the Gods Road  
Colorado Springs, Colorado 80907  
Contract No. DASA-01-68-C-0084**

## ABSTRACT

The basic theory governing the behavior of magnetically driven flyer plates is derived and discussed. Analytical tools capable of predicting the nonlinear response of flyer plate systems are described, and one such tool is utilized to predict the behavior of a typical capacitor bank-magnetically driven flyer plate facility. Practical applications and achievements, including instrumentation and bank diagnostics, of operating systems are described. Consideration is given to uncertainties arising from a lack of definition of (1) the cushioning (air or magnetic) between the sample and flyer, (2) the thermodynamic condition of the flyer at impact, and (3) the degree of buckling of a curved flyer at impact with a curved test specimen. Particular attention is given to the high impulse capability of magnetically driven flyer plates. Theoretical predictions of the temperature rise in various materials due to  $I^2R$  heating are presented along with hydrodynamic calculations of the pressure-time history resulting from magnetically driven flyer plate impacts on tape wound nylon phenolic. Included in the summary is a discussion of the need for magnetically driven flyer plate loadings of structural items.

## TABLE OF CONTENTS

	<u>Page</u>
Abstract	ii
List of Figures	iv
List of Tables	v
Section 1 - Introduction	1
Section 2 - Magnetically Driven Flyer Plate Back-ground and Theory	3
Section 3 - Prediction of Magnetically Driven Flyer Plate Behavior	15
Section 4 - Application	29
Section 5 - Test Specimen Instrumentation and Capacitor Bank Diagnostics	37
Section 6 - Understanding of the Physics of Magnetically Driven Flyer Plate Impacts	39
Section 7 - High Level Capabilities of Magnetically Driven Flyer Plates	43
Section 8 - Conclusions and Recommendations	49
Bibliography	55
Appendix A	59

## LIST OF FIGURES

<u>Figure No.</u>	<u>Title</u>	<u>Page No.</u>
1	Side View of a Basic Magnetically Driven Flyer Plate Fixture	4
2	Basic Current, Field, and Force Relationship in an Infinite Thin Plate Geometry	6
3	Magnetically Driven Flyer Plate Equivalent Circuit	8
4	Simplified Capacitor Bank-Magnetically Driven Flyer Plate Schematic	11
5	Schematic for Computer Code MULTIFL	17
6	Predicted Flyer Displacement, Velocity, and Magnetic Pressure Vs. Time (4.5 cm Wide Flyer)	18
7	Predicted Flyer Displacement, Velocity, and Magnetic Pressure Vs. Time (10 cm Wide Flyer)	19
8	Predicted Final Flyer Velocity Vs. Flyer Width	21
9	Predicted Velocity Vs. Time for Different Ca- pacitor Bank Resistance Values (4.5 cm Wide Flyer)	22
10	Predicted Flyer Velocity Vs. Time for Differ- ent Capacitor Bank Resistance Values (10 cm Wide Flyer)	23
11	Predicted Final Flyer Velocity Vs. Bank Resis- tance	24
12	Predicted Flyer Velocity Vs. Time for Differ- ent Bank Inductance Values	25
13	Predicted Flyer Velocity Vs. Capacitor Bank Voltage	27
14	Basic Arrangement to Obtain Cosine Pressure Distribution with Circumferential Current $i = i(\theta)$	31

LIST OF FIGURES (Cont'd)

<u>Figure No.</u>	<u>Title</u>	<u>Page No.</u>
15	Basic Arrangement to Obtain Cosine Pressure Distribution with Axial Current $i = i(Z)$	32
16	Predicted Flyer Velocity Vs. Temperature for Various 0.064 cm Thick Materials	44
17	PUFF V Predicted Pressure Vs. Time of Copper Flyer Impacting TWNP	46
18	PUFF V Predicted Pressure Vs. Time of Aluminum Flyer Impacting TWNP	47

LIST OF TABLES

I	Typical Magnetically Driven Flyer Plate Accomplishments	34
---	---	----

## 1.0 INTRODUCTION

The past few years have witnessed a rapid growth in the capabilities, in terms of both quantity and complexity, of magnetically driven flyer plate testing. At least eight agencies are actively using these flyers to create front surface impulsive loads. Test items range from 1" square material samples to full-size reentry vehicles. This report attempts to bring into perspective the techniques and capabilities, both current and long-range, of this type of testing.

Information was gathered for this report by personal contact with several agencies and from published literature. The agencies visited are listed in Appendix A. The bibliography refers to every report known to the authors which is directed at magnetically driven flyer plate testing. It is surprising that so few reports were located.

Section 2 of this report presents basic theoretical considerations concerning magnetically driven flyer plates. Section 3 extends the concepts of the former section by presenting brief descriptions of computer codes presently being used to predict flyer behavior and presents some typical predictions by one of these codes. These two theoretical sections were written more extensively than originally planned in an attempt to establish a proper foundation for the material which follows.

Section 4 is a brief summary of typical applications and achievements of magnetically driven flyer plates. Section 5 summarizes the instrumentation and diagnostics currently being used in support of magnetically driven flyer plates.

Section 6 contains discussions of items which are pertinent to understanding the detailed physics of the flyer-sample interaction.

Considerations of the high impulse, high pressure capabilities are presented in Section 7. Results of theoretical calculations are presented to substantiate the discussion.

Conclusions and recommendations are contained in Section 8.

The opinions in this report are those of the authors and do not necessarily correspond to the views of the individuals visited. Indeed, in some cases, different individuals had completely opposite viewpoints on a given subject. These disagreements invariably stem from a lack of documented data. An excellent example of this type of controversy is the debate as to the need for a coplanar flyer impact vs. the running load surface explosive. In our opinion, this debate has persisted due to the lack of a well-documented test series which directly compares the two methods. It is our hope that our own opinions (if they are considered controversial) will stimulate additional documentation.

Finally, we wish to take this opportunity to thank the many individuals contacted in conjunction with this survey for their time and cooperation. Without their help, this report could hardly be possible.

## **2.0 MAGNETICALLY DRIVEN FLYER PLATE BACKGROUND AND THEORY**

The phrase "magnetically driven flyer plate" refers to an electrically conductive material which is propelled by the Lorentz force generated between two current carrying members located in an appropriate geometry. Figure 1 is a schematic diagram illustrating the basic parts of a magnetically driven flyer plate fixture. The flyer and backstrap combination form a parallel plate transmission line system carrying a series current. The Lorentz force (magnetic pressure) created between the current carrying members and their self-generated magnetic fields is a repulsive force. Thus, if the backstrap is massive compared to the flyer, the flyer is repelled away from the backstrap.

The energy sources for magnetically driven plates are usually high-voltage, low-inductance capacitor banks. These capacitor banks (when connected to typical magnetically driven flyer plate loads) have discharge frequencies in the neighborhood of 100 khz. Thus, the flyer plates obtain most of their kinetic energy in the range of a few to a few tens of microseconds. These capacitor banks normally provide peak currents between  $10^5$  and  $10^7$  amperes to a magnetically driven flyer plate. Multimegampere discharges can readily produce magnetic pressures of  $10^4$  to  $10^5$  psi on the flyer and backstrap.

The detailed understanding of a capacitor bank-magnetically driven flyer plate facility must consider the entire time dependent response of the system. However, considerable insight into the flyer plate behavior may be obtained by considering the magnetic pressure which exists in an idealized infinite-sheet, parallel-plate transmission line.

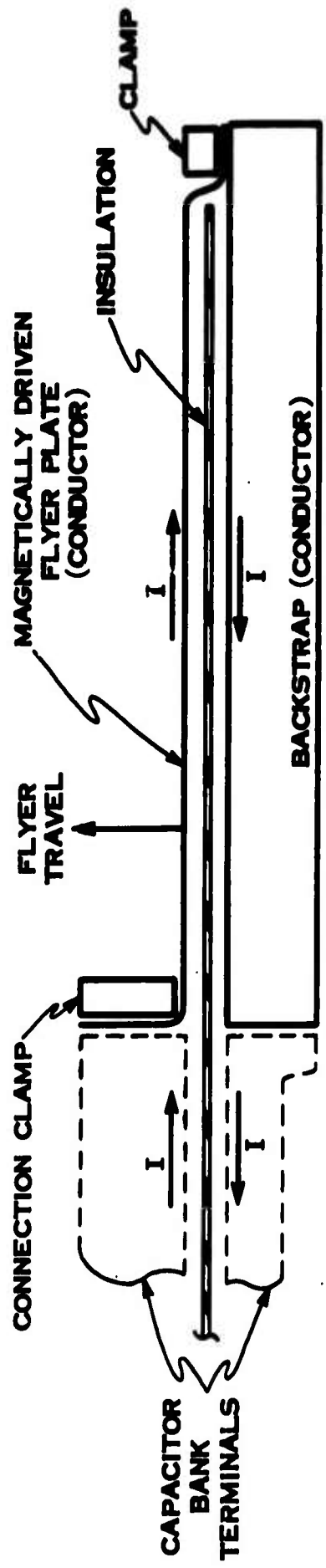

FIGURE 1

SIDE VIEW OF A BASIC MAGNETICALLY DRIVEN FLYER PLATE FIXTURE

In an infinite width geometry (Figure 2), the magnetic field  $B$  does not exist on the outside of the plates.

Combining the basic force equation

$$\vec{f} = \vec{i} \times \vec{B} \quad (1)$$

with Maxwell's equation governing the relationship between current and magnetic field  $\vec{H}$

$$\vec{i} = \vec{\nabla} \times \vec{H} = \frac{1}{\mu} \vec{\nabla} \times \vec{B} \quad (2)$$

we have the following expression for the force per unit volume within the conductors

$$\vec{f} = \frac{-1}{2\mu} \frac{\partial B_x^2}{\partial y} \vec{i}_y = - \frac{1}{\mu} B_x \frac{\partial B_x}{\partial y} \vec{i}_y \quad (3)$$

where

- $\vec{f}$  - force per unit volume,
- $\vec{i}$  - current density,
- $\vec{B} = B_x \vec{i}_y$  - flux density,
- $\vec{H}$  - magnetomotive force, and
- $\mu$  - permeability.

The force per unit area (pressure) is then obtained by integrating the body force through the conductor thickness.

$$\vec{P} = + \frac{1}{2\mu} B_x^2 \vec{i}_y \quad (4)$$

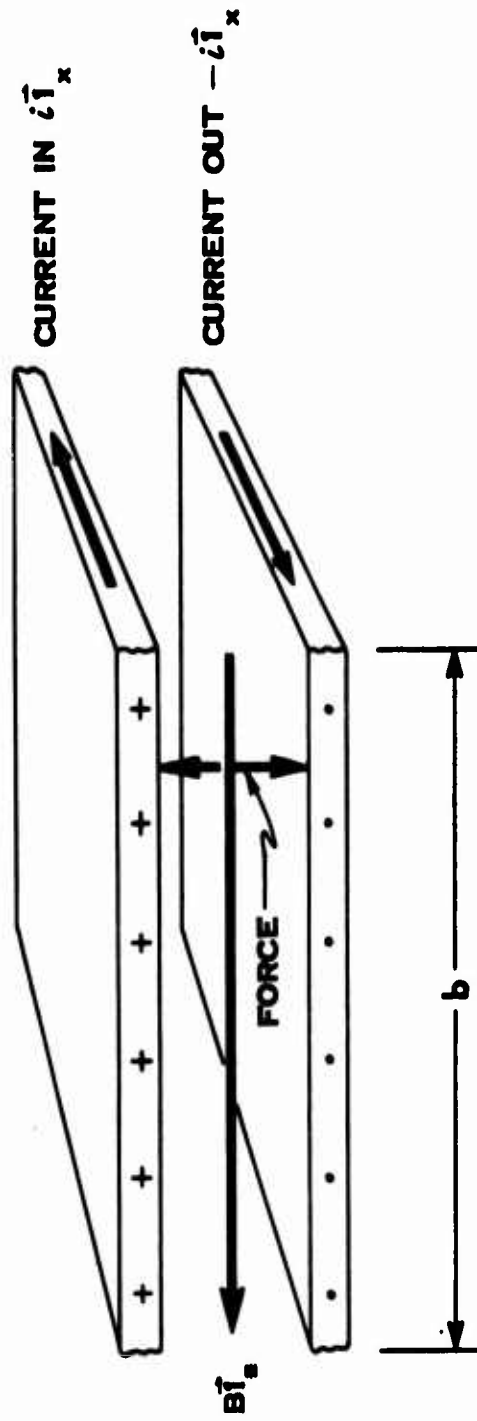

MAGNETIC  
FIELD  
DENSITY  $B$

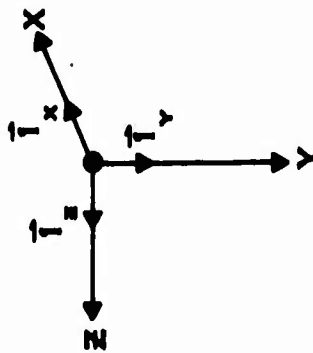

FIGURE 2

BASIC CURRENT, FIELD AND FORCE RELATIONSHIP  
IN AN INFINITE THIN PLATE GEOMETRY

Therefore, the pressure exerted on either conductor is proportional to the square of the field strength and tends to force the conductors apart.

Utilizing the basic expression for the energy density ( $w$ ) contained in a magnetic field, one sees that (in scalar notation)

$$w = \frac{1}{2} BH = \frac{1}{2\mu} B^2 \quad (5)$$

Therefore, the "magnetic pressure" is numerically equal to the energy density contained in the magnetic field. This situation, which is exactly analogous to the case of a contained gas, is extremely useful in envisioning the forces created in a current carrying system.

It is also useful to obtain the forcing function by considering the energy flow within the circuit. The electrical energy input must be accounted for by changes in the stored mechanical and magnetic energy, as well as resistive losses. This energy balance is expressed in Equation (6).

$$dW_{elec} = dW_{loss} + dW_{mech} + dW_{field} \quad (6)$$

$W$  - total energy

The magnetically driven flyer plate load may be represented by a resistor and variable inductor in series as shown in Figure 3.

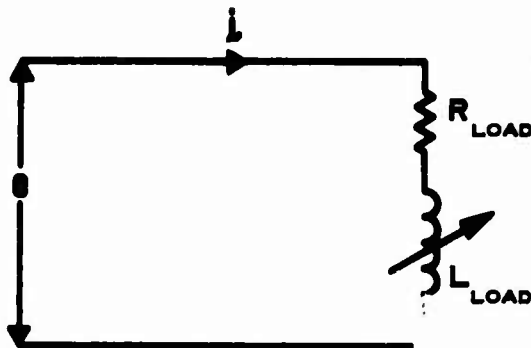

**FIGURE 3**  
**MAGNETICALLY DRIVEN FLYER PLATE EQUIVALENT CIRCUIT**

The electrical energy input to the load is expressed as

$$dW_{elec} = e i dt \quad (7)$$

where

$e$  - voltage

$i$  - current.

Since the voltage  $e$  may be expressed as

$$e = iR + \frac{d(Li)}{dt} \quad (8)$$

Equation (7) may be rewritten as

$$dW_{elec} = i^2 R dt + i^2 dL + Li di \quad (9)$$

Since the energy stored in the magnetic field of an inductor is expressed as

$$W_{\text{field}} = \frac{1}{2} Li^2 \quad , \quad (10)$$

then

$$dW_{\text{field}} = Lidi + \frac{1}{2} i^2 dL \quad . \quad (11)$$

Finally, the resistance losses are expressed as

$$dW_{\text{loss}} = i^2 Rdt \quad . \quad (12)$$

The combination of Equations (6), (9), (11), and (12) yields

$$dW_{\text{mech}} = F dy = \frac{1}{2} i^2 dL \quad . \quad (13)$$

Hence, the total mechanical force exerted on the system is given by

$$F = \frac{1}{2} i^2 \frac{dL}{dy} \quad . \quad (14)$$

The expression for the inductance of a closely spaced parallel plate geometry is

$$L = \mu y \frac{l}{b} \quad (15)$$

where

- y - spacing between plates,
- l - length of the plates, and
- b - width of the plates.

Thus, the total force is given by

$$F = \frac{1}{2} i^2 \frac{\partial L}{\partial y} = \frac{1}{2} i^2 \mu \frac{t}{b} \quad (16)$$

or, in terms of pressure,

$$P = \frac{\mu}{2} \left( \frac{i}{b} \right)^2 = \frac{\mu}{2} J^2 \quad (17)$$

where  $J$  is the current/unit width.

Even though Equation (17) is derived on the basis of a one-dimensional set of transmission lines, it furnishes considerable insight into magnetically driven flyer plate behavior. For instance, it is significant that for a given current vs. time waveform, both the instantaneous magnetic pressure and the flyer plate momentum density (i.e., the time integral of the magnetic pressure) are only dependent on the width of the flyer plate. Hence, this simplified analysis predicts that flyer plate density and thickness can only modify the momentum density of the flyer plate to the extent that they can modify the current waveform.

Assuming a one-dimensional flyer plate, the total momentum contained in a flyer plate may be obtained by multiplying the pressure by the flyer area and integrating with respect to time. Therefore, the total momentum,  $I$ , is expressed as

$$I = \frac{\mu t}{2b} \int_0^t i^2 dt \quad (18)$$

The kinetic energy of the flyer is from kinematics

$$\text{K.E. flyer} = \frac{I^2}{2m} - \frac{\mu^2 c^2}{8b^2 m} \left[ \int_0^t i^2 dt \right]^2 \quad (19)$$

Therefore, in a linear circuit where  $\int i^2 dt$  is independent of the flyer mass, a massive flyer tends to be inefficient in terms of energy conversion, even though the momentum of the flyer tends to be independent of the flyer mass.

The effects of various circuit parameters may be discussed with the aid of a schematic drawing of a typical capacitor bank-magnetically driven flyer plate facility as shown in Figure 4.

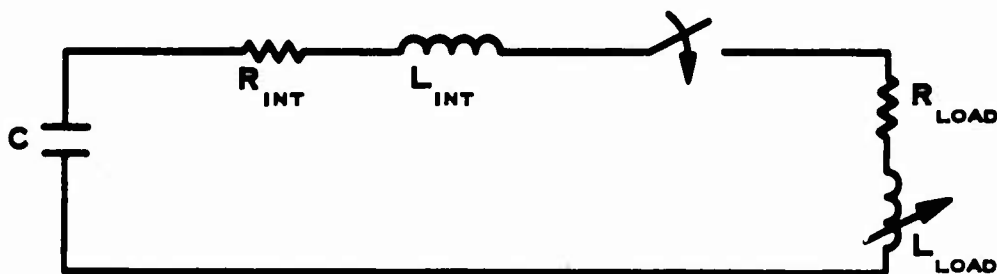

FIGURE 4  
SIMPLIFIED CAPACITOR BANK-MAGNETICALLY  
DRIVEN FLYER PLATE SCHEMATIC

The internal (int) values of resistance and inductance are to be found in the capacitor bank, switches, and transmission lines.

Since most typical capacitor bank driven flyer plate facilities are underdamped, the current discharge is approximated by an exponentially-decaying sine wave; hence,

the energy oscillates between the capacitor ( $1/2 C e^2$  electrostatic energy) and the load inductances ( $1/2 L i^2$  magnetostatic energy). Energy is dissipated in the form of heat ( $i^2 R$  losses) and is extracted from the electrical circuit by  $1/2 m v^2$  kinetic energy of the accelerated flyer. Since  $i^2 R$  losses remove energy from the circuit, resistance should be minimized for maximum efficiency.

The time derivative of Equation (13)

$$\frac{dW_{\text{mech}}}{dt} = \frac{1}{2} i^2 \frac{dL}{dt} - \frac{1}{2} i^2 v \frac{dL}{dy} \quad (20)$$

where  $v$  = velocity

is useful in determining the effects of the circuit parameters on the flyer performance. Since  $\frac{dL}{dy}$  is a constant for a true parallel plate geometry, the current flow and the flyer velocity determine the rate of energy transferred to the flyer. Hence, minimization of the circuit impedances (high current) and flyer mass (high velocity) will both tend to maximize the power flow to the flyer. Additional examinations of the effects of circuit inductance on energy conversion efficiency appear in References 1 and 2.

Another critical factor in considering the performance of magnetically driven flyer plates is the amount of heating of the flyer due to  $i^2 R$  losses. An estimate of the velocity limitation due to heating may be obtained from the following simplified analysis.<sup>1</sup>

From kinematics:

$$v = \frac{A}{m} \int_0^t P dt = \frac{Au}{2mb^2} \int_0^t i^2 dt \quad (21)$$

where

- v - velocity,
- A - cross-sectional area = ba,
- m - mass, and
- t - time.

If a uniform current density is assumed, the joule heating within the flyer is related to the flyer temperature as follows:

$$\int_0^t i^2 R dt = \frac{l}{ba} \int_0^t i^2 r_0 (1 + \alpha \tau) dt = m(H_0 + C_p \tau) \quad (22)$$

where

- $\alpha$  - temperature coefficient of resistivity,
- $r_0$  - initial resistivity,
- $l$  - flyer length,
- $a$  - flyer thickness,
- $\tau$  - temperature change,
- $H_0$  - enthalpy/unit mass, and
- $C_p$  - specific heat.

By separating the variables of Equation (22) and combining with Equation (21), one sees that

$$v = \frac{a\mu C_p}{2r_o} \int_{\tau_1}^{\tau_2} \frac{d\tau}{[1+\alpha\tau]} \quad (23)$$

Thus, the velocity is related to the flyer temperature change as follows:

$$v = \frac{a\mu C_p}{2r_o \alpha} \ln [1+\alpha\tau]_{\tau_1}^{\tau_2} \quad (24)$$

Caution should be used in applying Equation (24) to a practical system since edge effects and high frequency skin depth effects are not accounted for. If the flyer is thinner than the skin depth, Equation (24) is probably a reasonable approximation. If the skin depth is less than the flyer, the thickness constant ( $a$ ) should be replaced with the skin depth to predict the temperature rise within the depth from the surface where current flows. It is interesting to note that Equation (24) predicts a unique value of temperature vs. velocity independent of the current waveform.

### **3.0 PREDICTION OF MAGNETICALLY DRIVEN FLYER PLATE BEHAVIOR**

In practice, an efficient and practical magnetically driven flyer plate facility consists of a highly nonlinear circuit. A typical flyer plate load inductance may change from a rather small percentage of the initial circuit inductance to a value an order of magnitude greater than the initial total inductance. In addition, resistance values may change significantly due to joule heating. As a result of these nonlinearities, the equations developed in Section 2 of this report are primarily used for preliminary design and thinking tools but not for detailed design. Detailed experimental design is often conducted with computer codes--either digital or analog--to obtain a more accurate prediction.

Published data exist on the analog simulation of either capacitor bank<sup>3</sup> or explosive generator<sup>4</sup> systems. The referenced analog prediction of capacitor bank systems assumes a fixed value of circuit resistance and a variable inductance. The explosive generator predictions are accomplished with variable inductances at both the generator and load as well as a variable resistance within the flyer.

A digital code which predicts the behavior of a capacitor bank-magnetically driven flyer plate is described in Reference 5. This code assumes constant resistance values and a variable load inductance based on a linear inductance model. This report also presents experimental data showing measured deviation away from the theoretical value of parallel plate inductance. The magnetically driven flyer plate behavior is then calculated on the basis of a straight line approximation to the inductance measurements.

A finite difference code called MAGFL<sup>6</sup> is also applicable to capacitor bank driven flyer plates. This code contains the capability to account for variable bank and transmission line resistance values as functions of deposited energy. It also includes a non-linear variable inductance model of the flyer and an L-R series crowbar circuit which may be switched in at any given time.

An outgrowth of MAGFL is a computer code called MULTIFL<sup>7</sup>. This code can model a flyer of arbitrarily initial shape with an arbitrary spatial variation in magnetic pressure. MULTIFL options include the ability to stop portions of the flyer after a predetermined flight distance. The schematic for MULTIFL is shown in Figure 5. As seen in Figure 5, MULTIFL allows the flyer to be modeled into a 10x10 matrix of mechanically uncoupled, time varying elements. Each matrix element consists of a resistor, which varies as a function of deposited energy, and an inductor which varies with flyer position. The matrix resistance elements are those calculated by steady state skin depth formulas based on the frequency at that particular time step. The inductance model can be either linear or nonlinear where the nonlinear model is based upon a theoretical two-dimensional inductance calculation.

MULTIFL was used to predict the curves shown on Figures 6 through 13. These curves indicate the behavior of magnetically driven flyer plates under various conditions with a rather modest capacitor bank operating through the range of 3 to 70 kilojoules. Figures 6 and 7 illustrate the time varying stimulus and response of two flyer plates of different widths. These curves indicate the appreciable magnetic pressure (kilobars) that may be achieved to

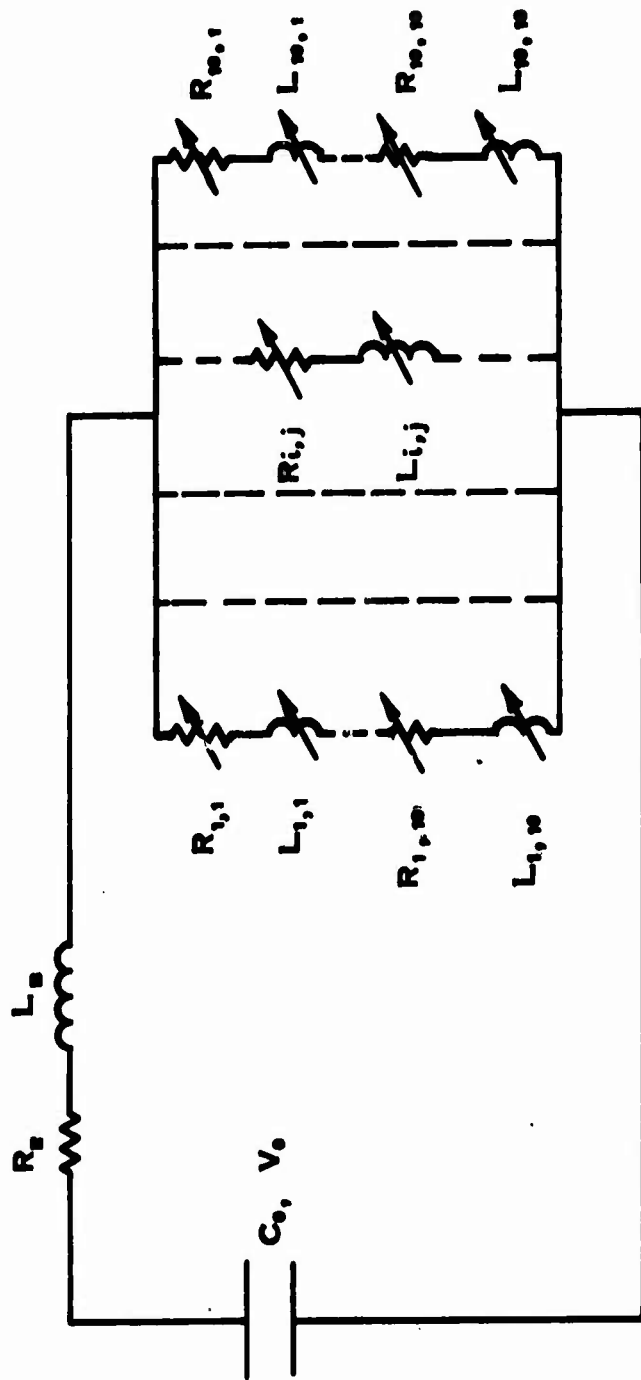

$i, j = 1 \rightarrow 10$

FIGURE 5  
SCHEMATIC FOR COMPUTER CODE MULTIPLY

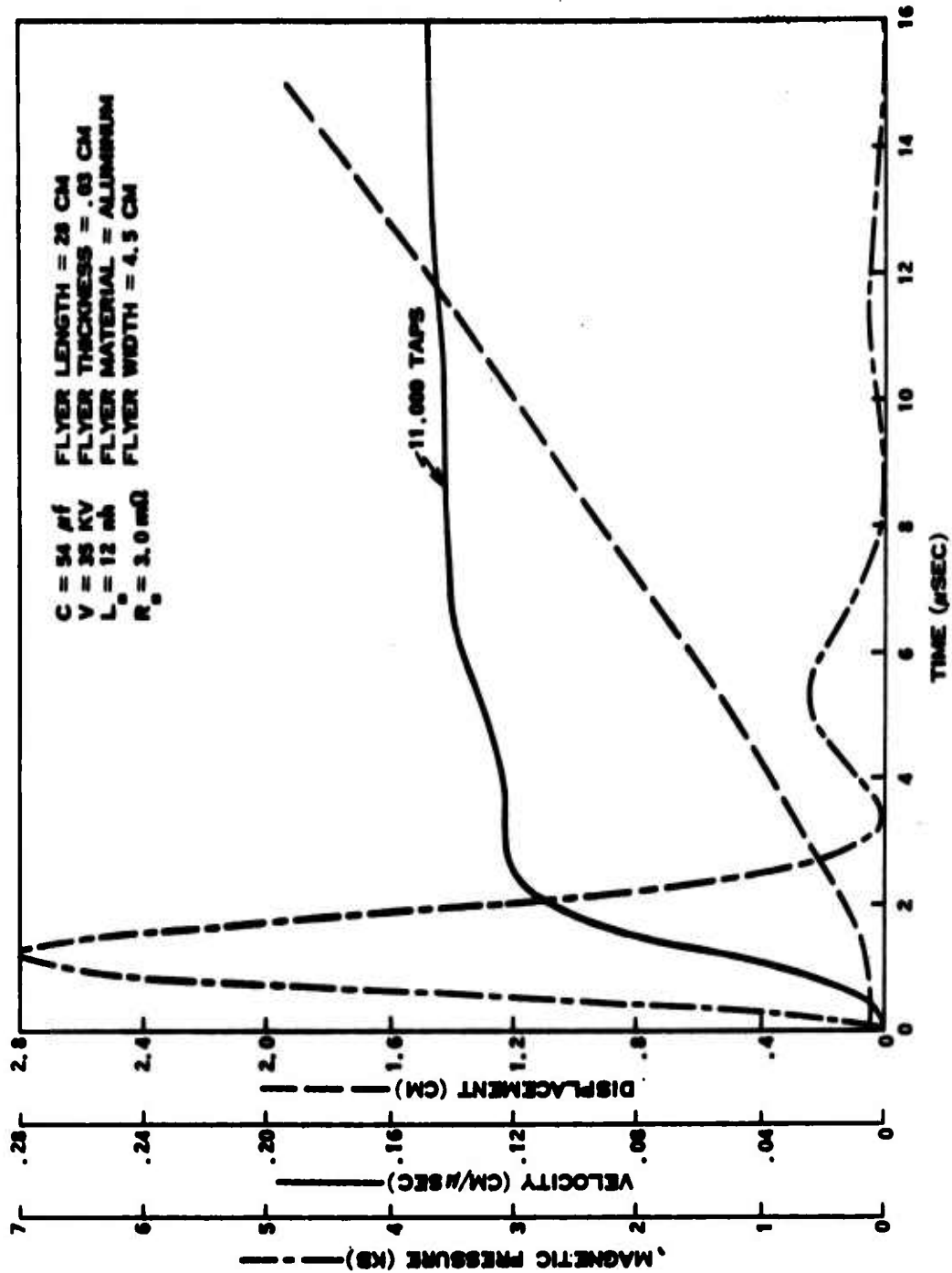

FIGURE 6

PREDICTED FLYER DISPLACEMENT, VELOCITY AND MAGNETIC PRESSURE VS TIME (4.5 CM WIDE FLYER)

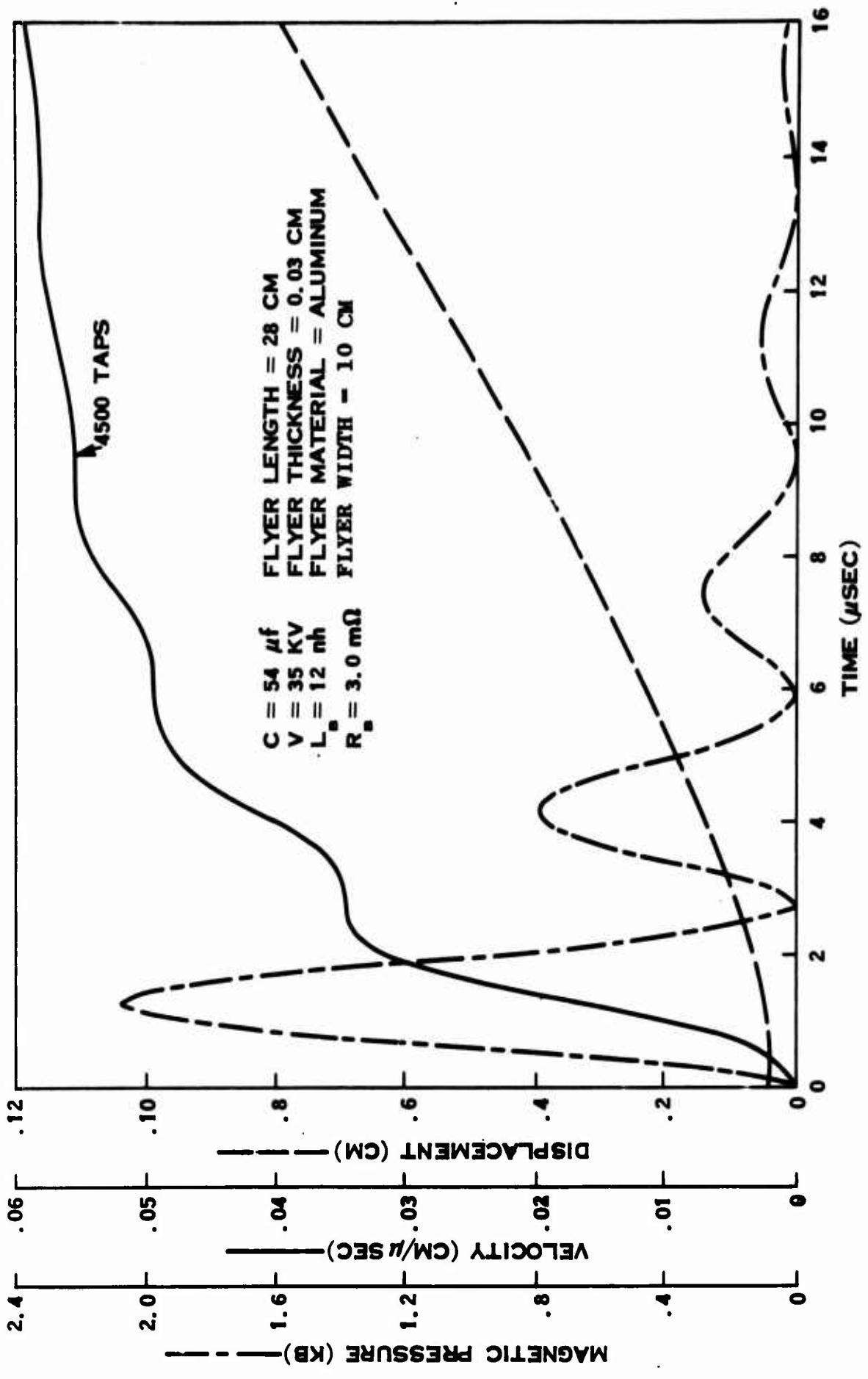

FIGURE 7

PREDICTED FLYER DISPLACEMENT, VELOCITY AND MAGNETIC PRESSURE VS TIME (10 CM WIDE FLYER)

drive magnetically driven flyer plates. These two sets of curves also provide an excellent example of the need for a nonlinear computer code to accomplish proper experimental design. For instance, it is not obvious that a fast flyer will reach a final velocity in a shorter distance than a slow flyer. The reason for the apparent anomaly of the faster flyer reaching a uniform velocity in a shorter distance than a slower flyer is the more efficient rate of energy conversion of the narrower flyer. Also note that the wide flyer has only achieved 2/3 of its momentum after a travel of 0.1 cm. Hence, if a test sample was placed at a spacing of 0.1 cm, the sample would receive approximately 2/3 of its final momentum (depending on the acoustic impedances) from the flyer impact and the remainder from a late time current flow. Considerations of the effect of flyer plate width may be found in Reference 8.

The predicted velocity variation as a function of flyer plate width appears in Figure 8.

The effects of circuit resistance on the performance of typical flyer plates is shown in Figures 9, 10, and 11. It is perhaps surprising that the flyer velocity is quite dependent on the resistance even though conventional R-L-C circuit calculations would show that these circuits are all well underdamped. Similar results have been previously predicted.<sup>8</sup>

Figure 12 illustrates that nominal circuit impedance values will influence the rate of energy transfer to the flyer (as predicted by Equation (20)), but have very little effect on the final velocity.

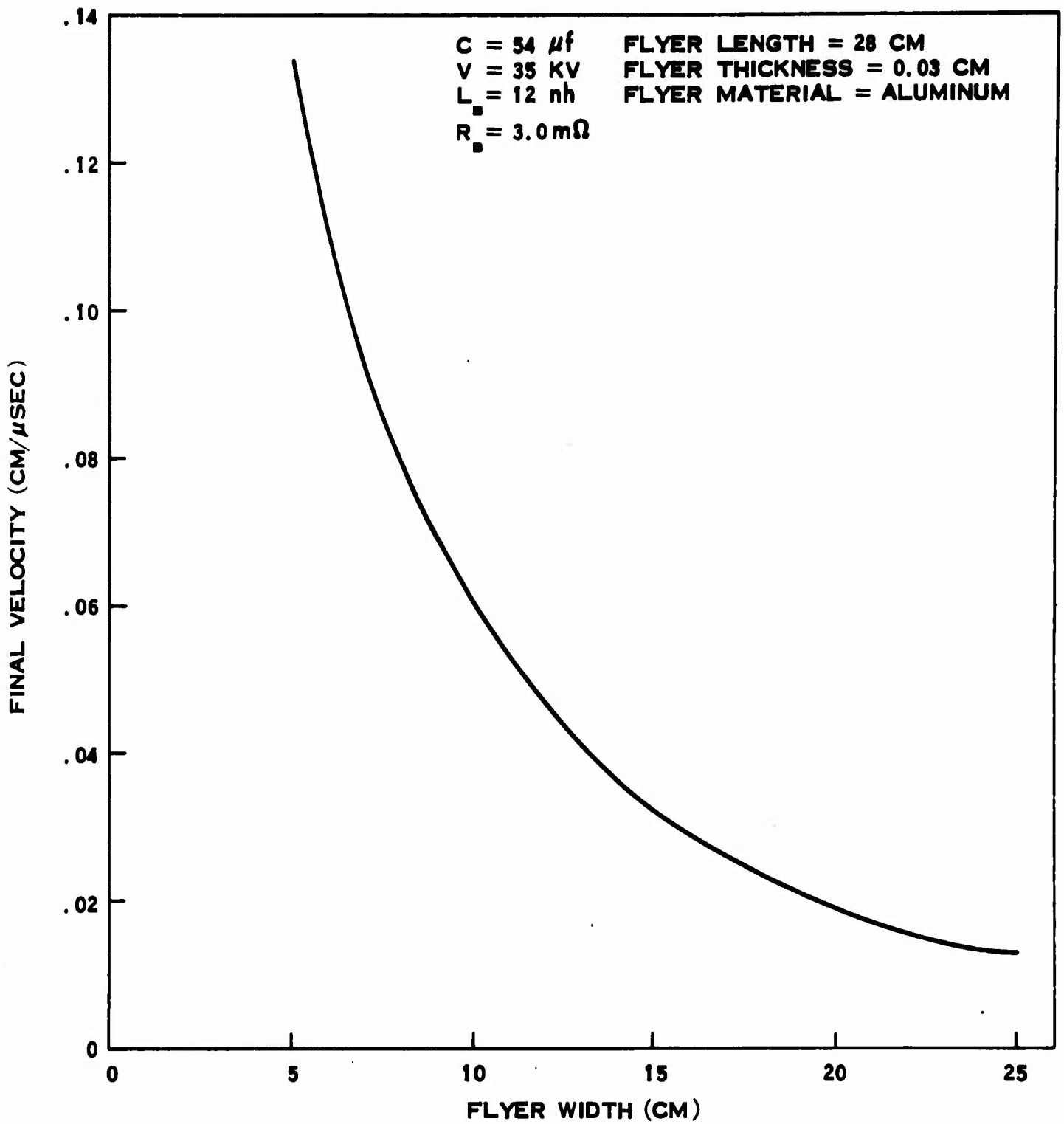
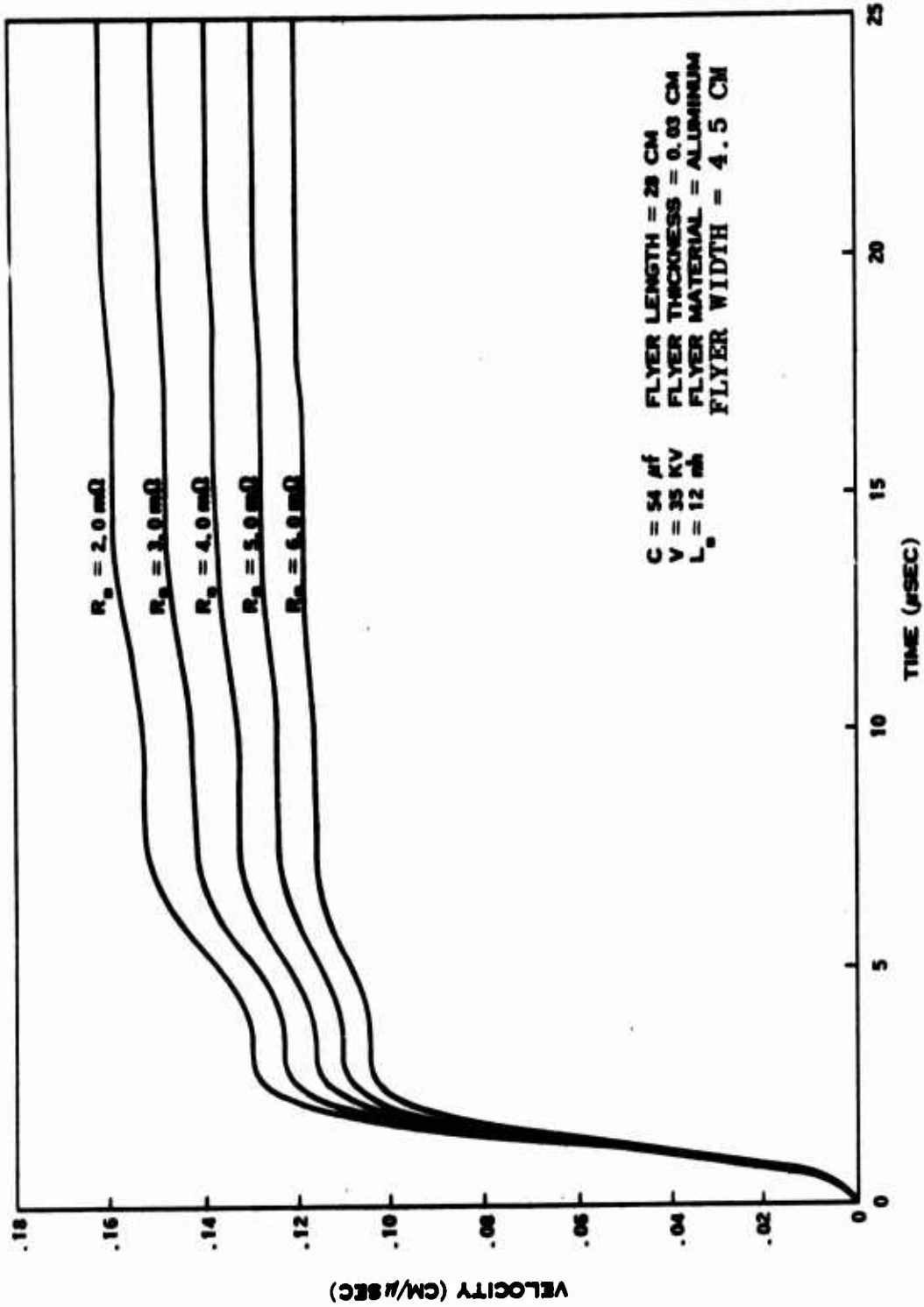
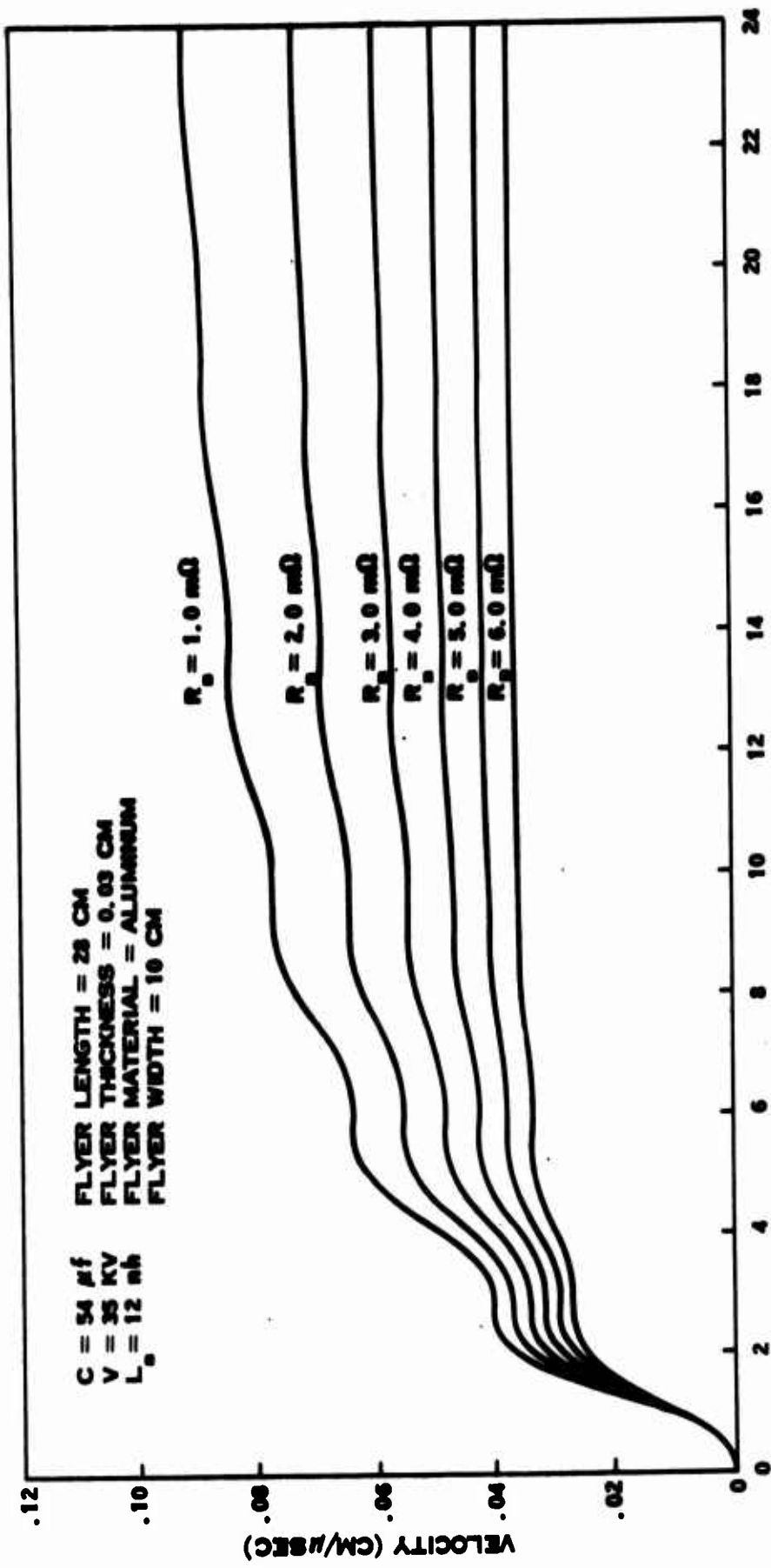

FIGURE 8

PREDICTED FINAL FLYER VELOCITY VS FLYER WIDTH



PREDICTED VELOCITY VS TIME FOR DIFFERENT CAPACITOR BANK  
 RESISTANCE VALUES (4.5 CM WIDE FLYER)  
 FIGURE 9



PREDICTED FLYER VELOCITY VS TIME FOR DIFFERENT CAPACITOR  
 BANK RESISTANCE VALUES (10 CM WIDE FLYER)  
 FIGURE 10

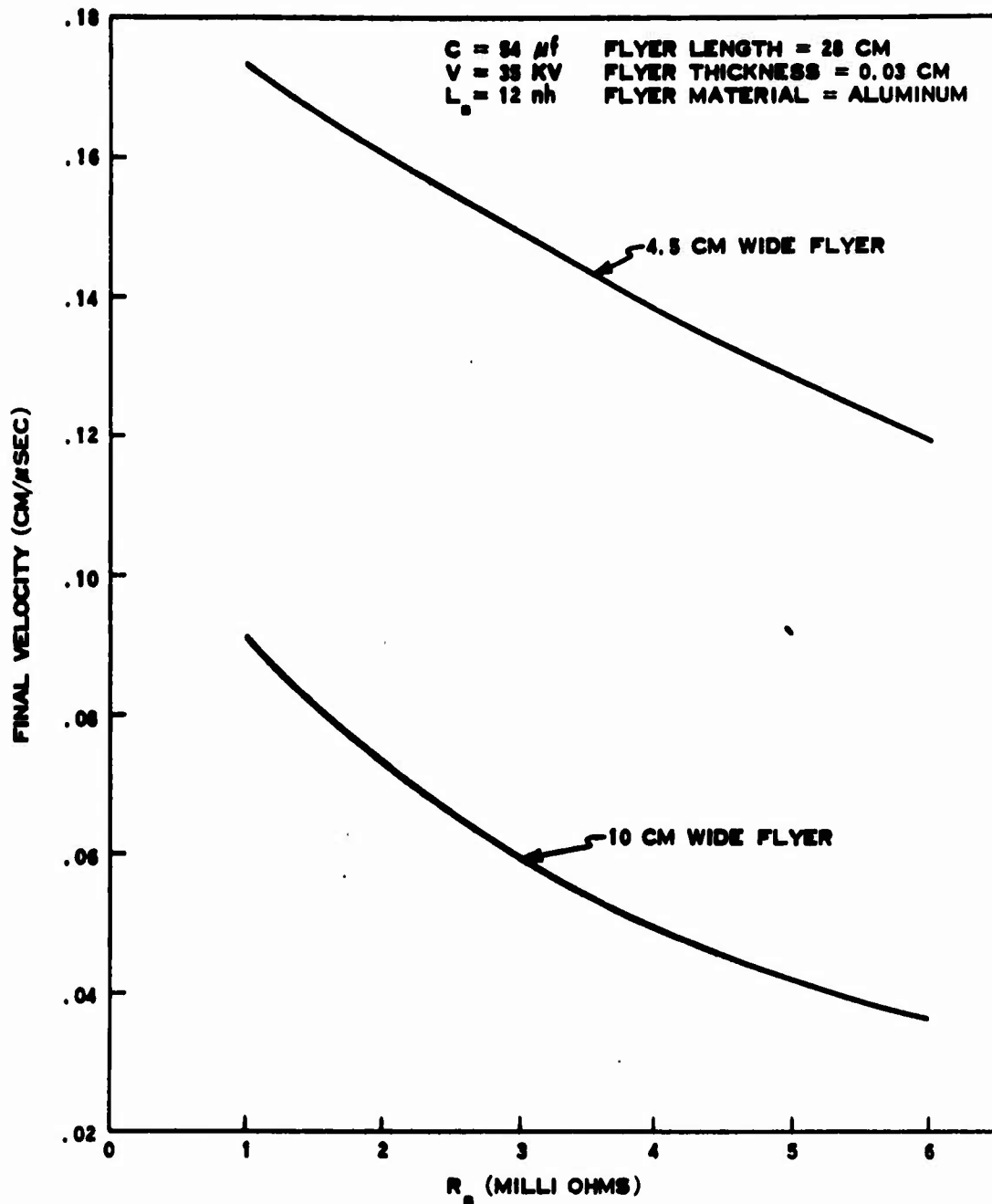

FIGURE 11

PREDICTED FINAL FLYER VELOCITY VS BANK RESISTANCE

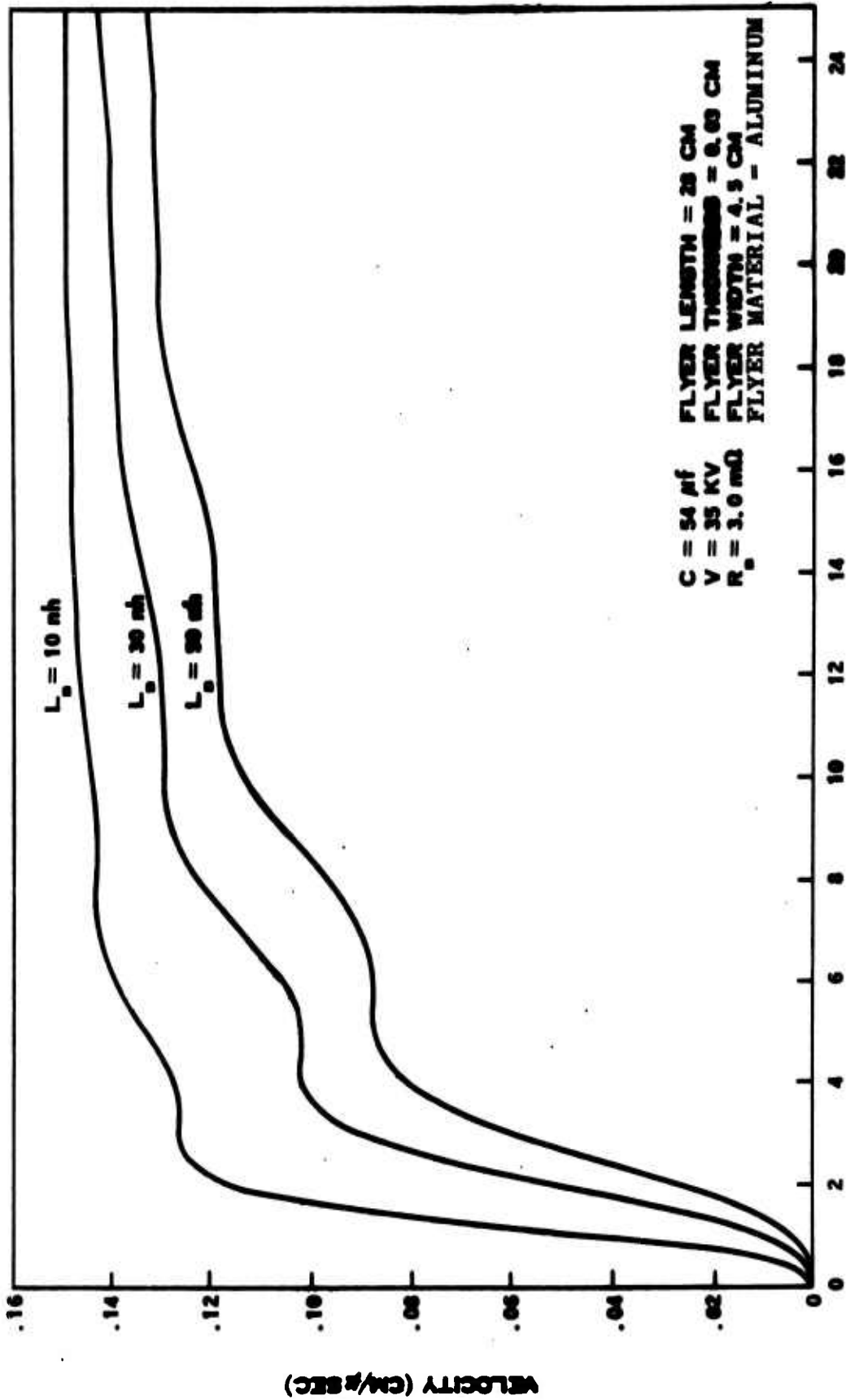
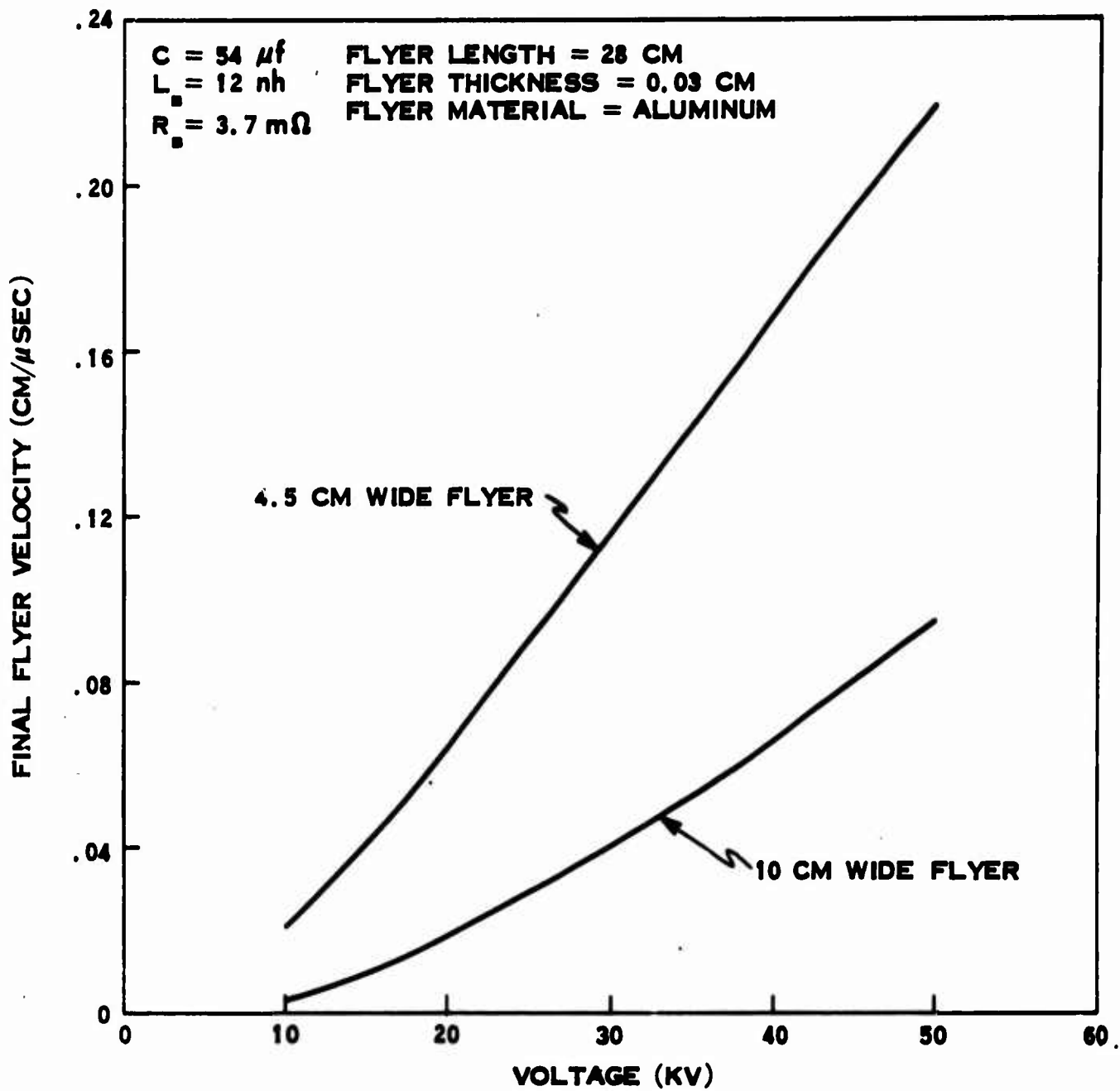

FIGURE 12

PREDICTED FLYER VELOCITY VS TIME FOR DIFFERENT BANK INDUCTANCE VALUES

Figure 13 shows predictions for the velocity variation as a function of capacitor bank voltage. As would be expected, the flyer velocity is strongly dependent on the capacitor bank voltage. Indeed, it may be shown that for a totally linear circuit, the kinetic energy could be expected to vary as the fourth power of voltage.<sup>9</sup>

It is significant to note that the capacitor bank-magnetically driven flyer codes all model the energy source as a lumped capacitance; however, Maxwell Laboratories, Inc. has furnished several capacitor banks to users of magnetically driven flyer plates in which the capacitors act as distributed capacitance systems in a transmission line type of system. Hence, the existing computer codes do not correctly model these banks. No data have been published to date which delineate the error involved in approximating these distributed capacitance systems with a lumped capacitor; however, the nonlinearities of these systems hint that a lumped capacitance model is insufficient. Although there are no known codes which can make pre-shot predictions for these nonlinear systems, a method has been developed<sup>10</sup> which allows a prediction of the flyer velocity at impact provided an uncalibrated current vs. time trace and the flyer arrival time are known.



**FIGURE 13**

**PREDICTED FLYER VELOCITY VS CAPACITOR BANK VOLTAGE**

**this page intentionally left blank**

#### 4.0 APPLICATION

Magnetically driven flyer plates are used to provide impulsive loads on the surface of one-dimensional material samples, as well as on two- and three-dimensional structural test items, by a number of different agencies. These experiments include both uniform and spatially varying impulsive loads.

High-energy, low-inductance capacitor banks are normally used as the energy source to drive magnetically driven flyer plates. These banks normally have peak operating voltages in the range of 20 to 60 kilovolts. Close-coupled, parallel-plate transmission lines are used to minimize inductance. The total impedance of bank, transmission line, and switch is normally a few milliohms (resistive) and 3 to 20 nanohenries (inductive). Total energy storage of these capacitor banks is typically between 20 and 400 kilojoules, although multimegajoule banks are in operation for other purposes. Explosive amplification systems<sup>11</sup> have been developed which amplify the electrical energy by more than an order of magnitude. These electroexplosive devices produce multimegampere currents with an inductive internal impedance.

The one-dimensional experiments are normally designed to investigate one-dimensional strain level failures<sup>12,13,14</sup> or to determine wave propagation characteristics in material samples. The actual experimental details vary among laboratories, but the flat flyers normally have a length/width ratio of 2 to 10 to minimize end effects due to both magnetic and mechanical perturbations. Also, the current density tends to be highest near the outer edges of the flyer<sup>7</sup> so that they have a tendency to curl upwards. Although edge

effects can be controlled a certain amount<sup>15</sup>, most flat flyers are designed wider than the test sample by 10 to 50 percent to enhance the impact planarity.

Two-dimensional flyer experiments include impulsive loading on rings and cylinders. Typically, these surface loads are applied over an area of the test specimen which is included within an arc of 160° to 180° around the longitudinal axis of the test specimen. The loading is commonly given a cosine variation of velocity around the center line ( $\theta = 0^\circ$ ). In order to effect a spatial velocity variation, it is necessary to control the spatial current density. For instance, the linear approximation in Equation (17) indicates that  $J = J_0 (\cos \theta)^2$  is necessary to obtain a  $\cos \theta$  pressure distribution. The method of obtaining a variation in magnetic pressure depends on the desired geometry of the current direction relative to the test specimen. As shown in Figure 14, the density of a circumferential (relative to the test specimen coordinates) current flow may be varied by changing the width of the flyer. With reference to Figure 15, the density of an axial current may be varied by changing the flyer to backstrap spacing such that the flux density is varied across the flyer plate width.

Three-dimensional shapes, such as re-entry vehicles, conical frusta, and nose tips, have also been impulsively loaded with spatially varying loads by extending and/or combining the above techniques of varying the current density.

The actual capabilities and accomplishments of various laboratories vary due to different energy sources, experimental goals, test techniques, and opinions. A listing of

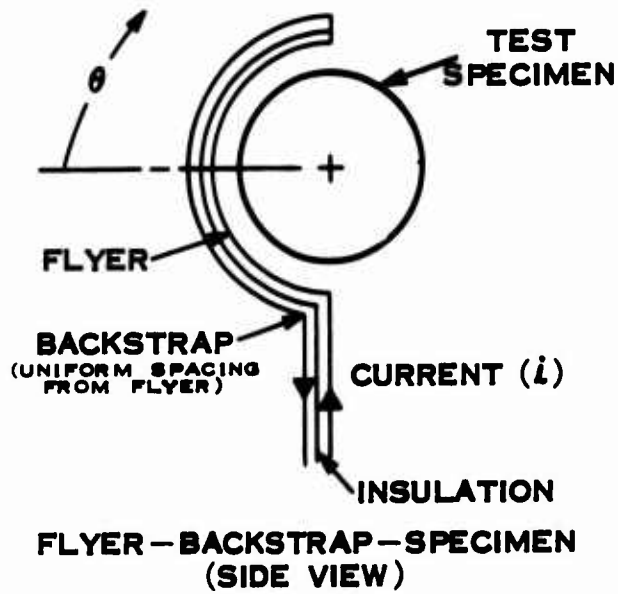

(FIGURE A)

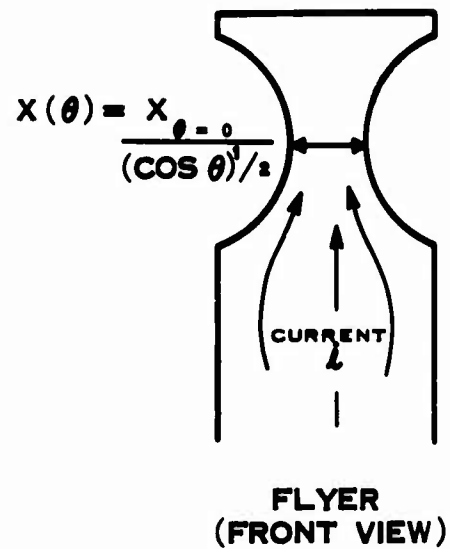

(FIGURE B)

FIGURE 14

BASIC ARRANGEMENT TO OBTAIN COSINE PRESSURE DISTRIBUTION  
WITH CIRCUMFERENTIAL CURRENT  $i = i(\theta)$

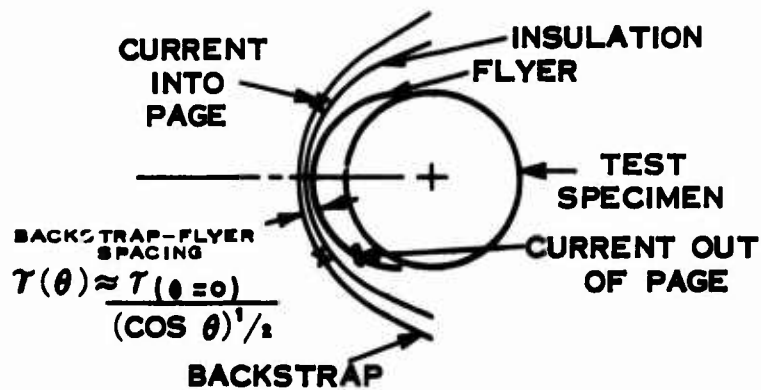

FLYER - BACKSTRAP - SPECIMEN  
(TOP VIEW)

(FIGURE A)

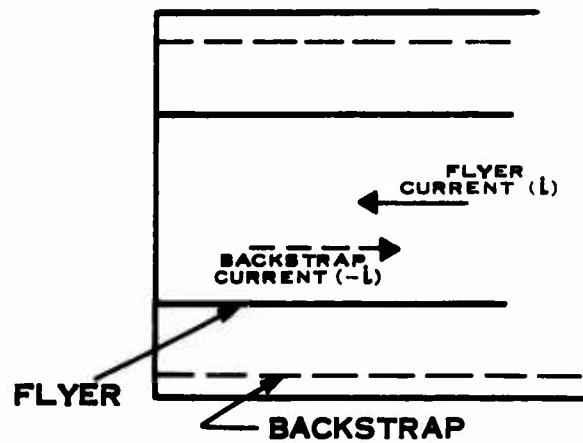

FLYER - BACKSTRAP  
(SIDE VIEW)

(FIGURE B)

FIGURE 15

BASIC ARRANGEMENT TO OBTAIN COSINE PRESSURE DISTRIBUTION  
WITH AXIAL CURRENT  $i = i(z)$

"typical" capabilities obtained with capacitor bank driven flyers appears in Table 1. The purpose of this tabular listing is to provide the reader with a feeling for typical experimental capabilities as opposed to precise definitions.

At least two facilities are currently conducting one-dimensional experiments in vacuum on a routine basis such that air-cushioning problems are eliminated. However, the authors are not aware of any facility currently conducting two- and three-dimensional experiments in vacuum. Evaluation of the effects of air cushioning is discussed in Section 6 of this report.

Flyer free runs prior to impact with the sample vary considerably depending on experimental goals and understanding. In general, a shorter free run produces a more planar impact, while the longer free run offers the advantages of reduced flyer voltage and magnetic pressure as well as a larger data acquisition time to monitor flyer behavior. Indeed, if the net momentum transferred to the sample is an important experimental criterion, the magnetic pressure-time integral occurring after impact of a short free run may cause an appreciable error in the transferred momentum as was previously discussed in Section 3. Another limiting factor in the case of excessive free runs is the mechanical response of the flyer. In the case of one-dimensional flyers, the mechanical end restraints tend to cause nonplanarity. During two- and three-dimensional experiments, the compressive hoop stresses generated when the flyer is driven radially inward tend to induce buckling instabilities within the flyer. The actual buckling vs. time for a given flyer plate has not been experimentally verified, although it does not appear to be a serious problem.

**TABLE I**  
**TYPICAL MAGNETICALLY DRIVEN FLYER PLATE ACCOMPLISHMENTS**

Capac. Bank Energy (KJ)	Material	Thickness (cm)	Width/ Circum- ference (cm)	Length (cm)	Velocity* (cm/μsec)	Momentum* Density (taps)
<b>A. <u>ONE-DIMENSIONAL</u></b>						
35	Al	0.03	4.4	28	0.13	10,600
35	Al	0.03	10	28	0.043	3,500
42	Al	0.10	2.5	15	0.092	24,000
<b>B. <u>TWO-DIMENSIONAL COSINE LOADS</u></b>						
300	Al	0.03	36	33	0.099	8,000
<b>C. <u>COSINE LOADS ON CONICAL FRUSTRA</u></b>						
135	Al/Poly- ethylene	0.015/ 0.08	75	140	0.012	1,300
400	Al	0.03	50	75	0.097	8,000
* Refers to peak value of cosine load						

The degree of impact planarity and simultaneity of impact are nearly impossible to generalize. For instance, the total closure time of the flyer with the sample surface is expected to be proportional to the flyer free run and inversely proportional to the flyer velocity. These variations in spacing and velocity can cause changes in excess of an order of magnitude in the total closing time. Most practical one-dimensional flyer tests produce closure time varying between 0.1 and 1.0  $\mu\text{sec}$ <sup>14</sup>, while most two- and three-dimensional tests will produce closures between 0.5 and 10  $\mu\text{sec}$ <sup>15</sup> depending on velocity, spacing, geometrical complexities, etc.

The repeatability of magnetically driven flyer plate facilities appears to depend on the type of switching used and the criteria by which it is measured. Spark gap switches have produced velocity repeatabilities<sup>12,13</sup> of 10 percent with a readout system error estimated at 5 to 10 percent. The same readout system indicated a 20 percent spread in velocity<sup>13</sup> with properly functioning dielectric switches. Pin switches measuring flyer time of arrival of a dielectric switch system indicated repeatability of approximately 10 percent. Hence, magnetically driven flyer facilities appear to produce a repeatability of approximately 10 percent.

In addition to the conventional flyer plate development, some limited testing<sup>17</sup> has been conducted on a "pusher" geometry in which the "flyer" is placed directly on an insulating layer which is in intimate contact with the specimen. Hence, the magnetic pressure generated on the flyer as the capacitor bank discharges is transmitted directly to the specimen. This technique provides a method of imparting momentum to the specimen with essentially perfect simultaneity and a low stress level. If a single pulse is required,

it then becomes necessary to switch a short circuit  
(crowbar) across the load after a half cycle.

## 5.0 TEST SPECIMEN INSTRUMENTATION AND CAPACITOR BANK DIAGNOSTICS

Virtually every form of instrumentation common to shock wave physics and structural response has been accomplished on specimens impacted with magnetically driven flyer plates. These diagnostic techniques have been successful as the result of extensive experimentation with careful attention to the details of RF and electrostatic shielding, isolation of ground loops, floating screen rooms, and other details. Although these techniques are hardly able to completely eliminate induced noise, they have been able to reduce noise to short enough times and/or low enough amplitude to obtain adequate signal-to-noise ratios. Documentation exists for the shielding techniques and data acquisition for early time strain and acceleration<sup>1,5</sup> measurements, as well as both quartz<sup>1,4</sup> and manganin<sup>18,19</sup> measurements. Late time displacement<sup>20</sup> measurements have also been accomplished in conjunction with ballistic pendulum measurements of momentum imparted to the test sample.

Optical data acquisition in the form of streak and framing camera records have been successfully obtained on capacitor bank experiments for a number of years. Also, laser interferometry<sup>21</sup> has been successfully used to record an early time, prompt shock pulse in conjunction with an exploding foil driven flyer plate.

Capacitor bank diagnostics utilize conventional methods of  $\frac{di}{dt}$  pickup loops and voltage probes.

Optical and electrical methods have been utilized to measure both flyer velocity and flyer planarity. Streak photography has been employed to measure both velocity and

planarity<sup>14</sup> as have capacitor discharge shorting pins<sup>16</sup>, PZT pins, and pins monitoring flyer voltage<sup>15</sup>. Framing cameras have also been used to monitor flyer velocity<sup>12,13</sup>. The measurement of flyer velocity is not as trivial as it might appear to be. Care must be taken with pins to insure that erroneous readings do not occur due to

- (a) high voltage on the flyer and/or the insulation necessary to prevent arcing;
- (b) perturbation of the flyer geometry due to a prior pin impact; or,
- (c) inherent nonplanarities in the flyer due to edge curling, edge effects, etc.

In general, optical methods are also sensitive to flyer non-planarities. In addition, any measuring technique must recognize the rapid variation in velocity which may be occurring as the flyer is in free flight as illustrated in Figures 8 and 9.

## 6.0 UNDERSTANDING OF THE PHYSICS OF MAGNETICALLY DRIVEN FLYER PLATE IMPACTS

In many experiments involving impulsive loads, it is desirable (if not necessary) to have a detailed knowledge of the physics of interaction between the sample and flyer. Hence, it is advisable to consider the equation-of-state, as well as the mechanical condition, of the flyer. Additional consideration must be given to adverse effects which may arise from: a) the air column between the flyer and sample; b) magnetic impulse which the electrical circuit may deliver to the flyer after impact; or c) magnetic cushioning effects due to the compression of stray magnetic fields.

The thermodynamic condition of a magnetically driven flyer plate is a function of the joule heating associated with the large time-varying current. The oscillatory nature of the current vs. time waveform causes most of the current to flow on the side of the flyer closest to the backstrap. Thus, since thermal diffusion effects are small on a micro-second time scale, a rather steep temperature gradient may exist through the material. These effects may be large enough to cause surface melting. To the extent that the equation-of-state of the flyer is temperature dependent, the impact pressure-time history is temperature dependent. The ramifications of a temperature dependent equation-of-state may vary depending on the experimental design. If the test specimen responds only to the total delivered momentum and the flyer has a higher shock wave impedance than the specimen, the experiment should be insensitive to the details of the flyer equation-of-state. At the other extreme, if the flyer has a lower shock wave impedance than the sample (such that the flyer rebounds) and the details of the pressure pulse within the sample are important, then changes in the

equation-of-state due to temperature should be known. At the present time, these data are virtually nonexistent for most materials.

Pertinent to understanding the physics of flyers impacting a specimen is the mechanical configuration of the flyer. In particular, a curved flyer being driven radially inward has a tendency to buckle as the material is compressed due to the ever-decreasing radius. At the present time, the theory of buckling of a magnetically driven flyer plate is not understood and is rather poorly defined experimentally. Most experimentalists feel that buckling is not a serious problem. For the most part, these feelings are based on the lack of evidence of buckling problems rather than as a result of documented test programs aimed at defining the degree of buckling. Although the experimental evidence does not clearly indicate serious buckling, the resolution of the examinations is questionable.

The uncertainty surrounding the degree of flyer buckling is somewhat compounded by the fact that no data seem to exist on the effect that a buckled vs. a nonbuckled flyer has on a given test specimen. Hence, it does not seem feasible to determine the degree of buckling by a post-mortem examination of the test sample.

The details of the flyer-sample interaction may also be affected by cushioning and the late time conversion of electrical energy to kinetic energy of the flyer. Cushioning between the flyer and the sample may be due to trapped air or possibly the compression of magnetic field lines between the sample and flyer. Preliminary studies have been conducted to determine the effects of an air column. These studies<sup>20</sup> were conducted using free runs in the range

of 1/4" to 1/2" and consisted of a 2" wide flyer impacting a 1-1/2" square target at atmospheric pressure and at a hard vacuum. These tests demonstrated that air cushioning would cause the flyer to rebound away from an acoustically matched target. The increase of transferred momentum appears to be approximately 30 to 40 percent due to the air with the longer free run causing the larger momentum amplification. The one-dimensional spall level of ATJS graphite has also been demonstrated to be a function of the air pressure if the free-flight flyer velocity is the damage criterion<sup>12</sup>.

Apparently, the effects of magnetic cushioning between the sample and flyer have not been observed and/or identified. However, it is conceivable that magnetic field lines could be trapped between the flyer and a conductive sample. As the flyer approaches contact with the sample, these lines would then be compressed between the two conductive materials giving rise to a magnetic pressure which in turn would produce a magnetic cushioning effect.

The effect of late time magnetic pressure causing additional momentum transfer to the sample can be a serious problem and was discussed in Section 3.

**this page intentionally left blank**

## 7.0 HIGH LEVEL CAPABILITIES OF MAGNETICALLY DRIVEN FLYER PLATES

Capacitor bank-magnetically driven flyer plate facilities in the United States are as large as 400 kilojoules. Electroexplosive generators with a total energy storage capability in excess of 10 megajoules have been successfully used to drive flyer plates. Neither of these energy sources represents a limit of technology. In fact, such things as energy storage, transmission lines, switches, etc., do not present a visible upper bound on the ultimate capabilities of magnetically driven flyer plates.

A common technological concern as to the limitation of magnetically driven flyer plates appears to be the condition of the flyer at impact. These interrelated conditions are:

- (a) Thermodynamic state of the flyer.
- (b) Magnetic pressure on, and momentum to be delivered to, the flyer plate.

To obtain an estimate of the thermal limitations due to joule heating, Equation (24) was utilized to predict the velocity vs. temperature plot of several materials. The thickness of the flyer material was arbitrarily chosen to be 0.064 cm. The material constants were chosen from handbooks and are taken to be independent of temperature. The plots of the predicted velocity vs. temperature appear in Figure 16. In each case, the plot terminates (and the momentum is listed) at the melting point of the material. Since most practical electrical skin depths are smaller than 0.064 cm, melting on the inner surface would be expected to occur earlier than the predictions shown in Figure 16. Even so,

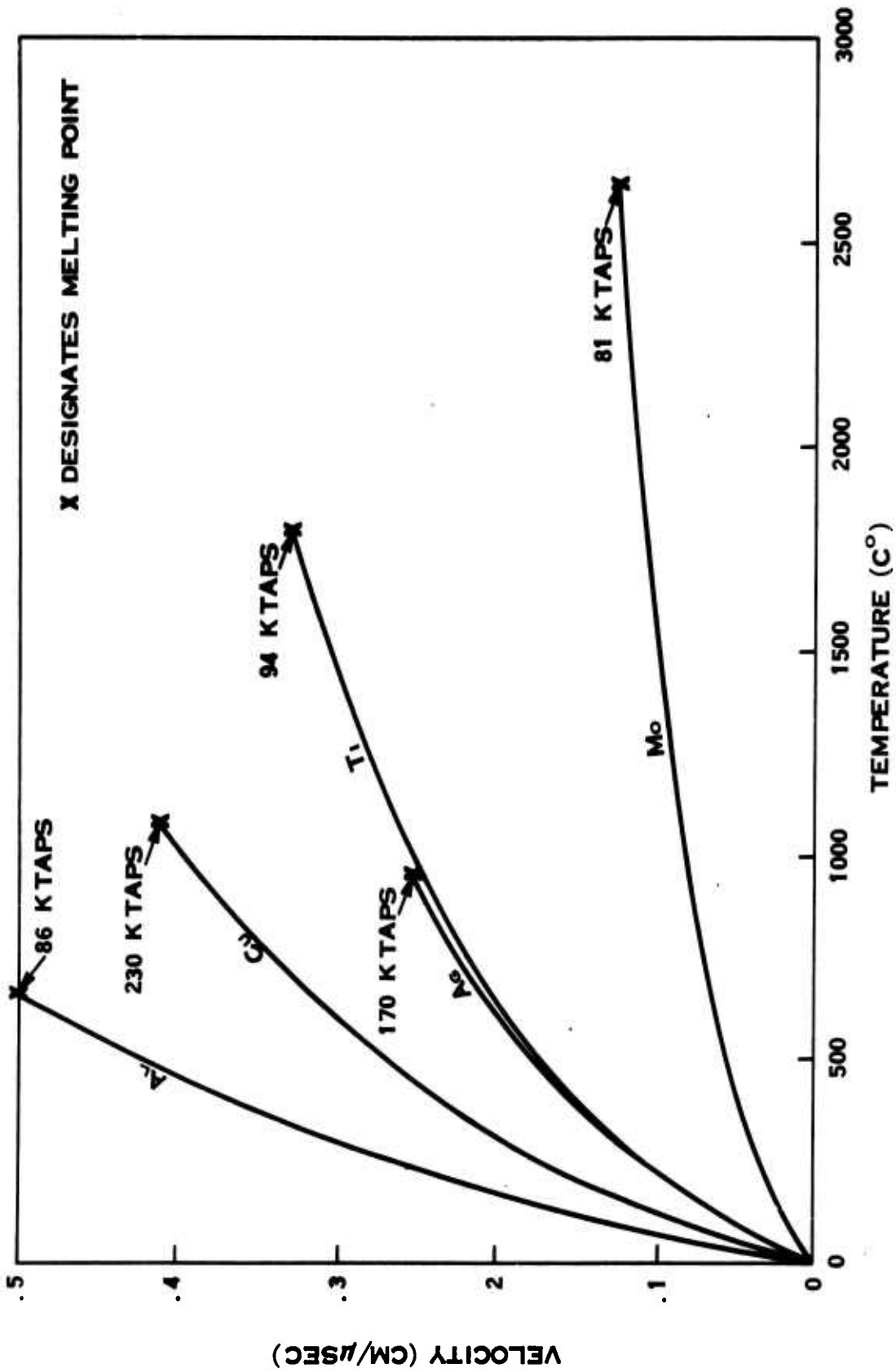

FIGURE 16  
 PREDICTED FLYER VELOCITY VS TEMPERATURE FOR VARIOUS  
 0.07 CM THICK MATERIALS

these curves predict that the melting point on a reasonable flyer thickness is hardly a restraint in terms of peak momentum. It should, perhaps, be noted that the theory of Equation (24) predicts that the momentum to melt varies as the square of the thickness. Hence, a 0.13 cm thick copper flyer could be expected to produce approximately  $10^6$  ktaps prior to completely melting. It has been stated<sup>11</sup> that a 0.16 cm flyer has been subjected to approximately 200 Ktaps (100 Ktaps in free flight and 100 Ktaps after impact) with only minor surface damage. It should also be noted that the melting point is an arbitrary limitation, and valid impulsive load tests could probably be conducted with a partially, or even completely, melted flyer.

The pressure-time profiles of two common flyer materials (aluminum and copper) impacting tape wound nylon phenolic (TWNP) are predicted as shown in Figures 17 and 18. The predictions were made with the elastic-plastic wave propagation computer code PUFF V<sup>23</sup>. The TWNP was represented by the following equation-of-state:

$$\begin{aligned} \text{Pressure (Mb)} = & 0.097\mu + 0.1323\mu^2 + 0.1820\mu^3 \\ & + 0.792(1+\mu)E \end{aligned} \quad (25)$$

where

$$\mu = \left( \frac{\rho}{\rho_0} - 1 \right)$$

E = energy (megabars-cc/cc)

The curves on Figures 17 and 18 provide some insight into the flexibility available with magnetically driven

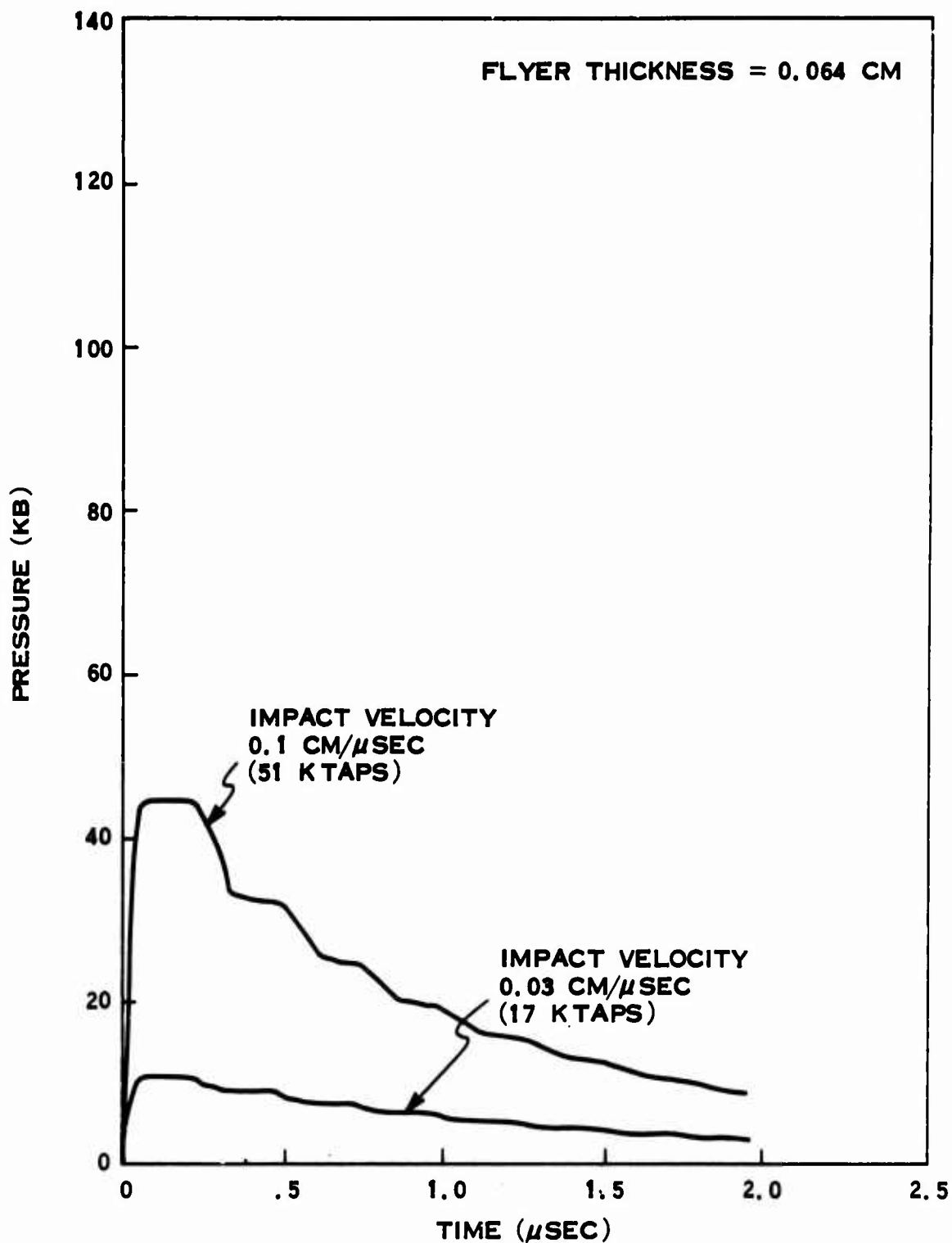

FIGURE 17

PUFF V PREDICTED PRESSURE VS TIME OF COPPER  
FLYER IMPACTING TWNP

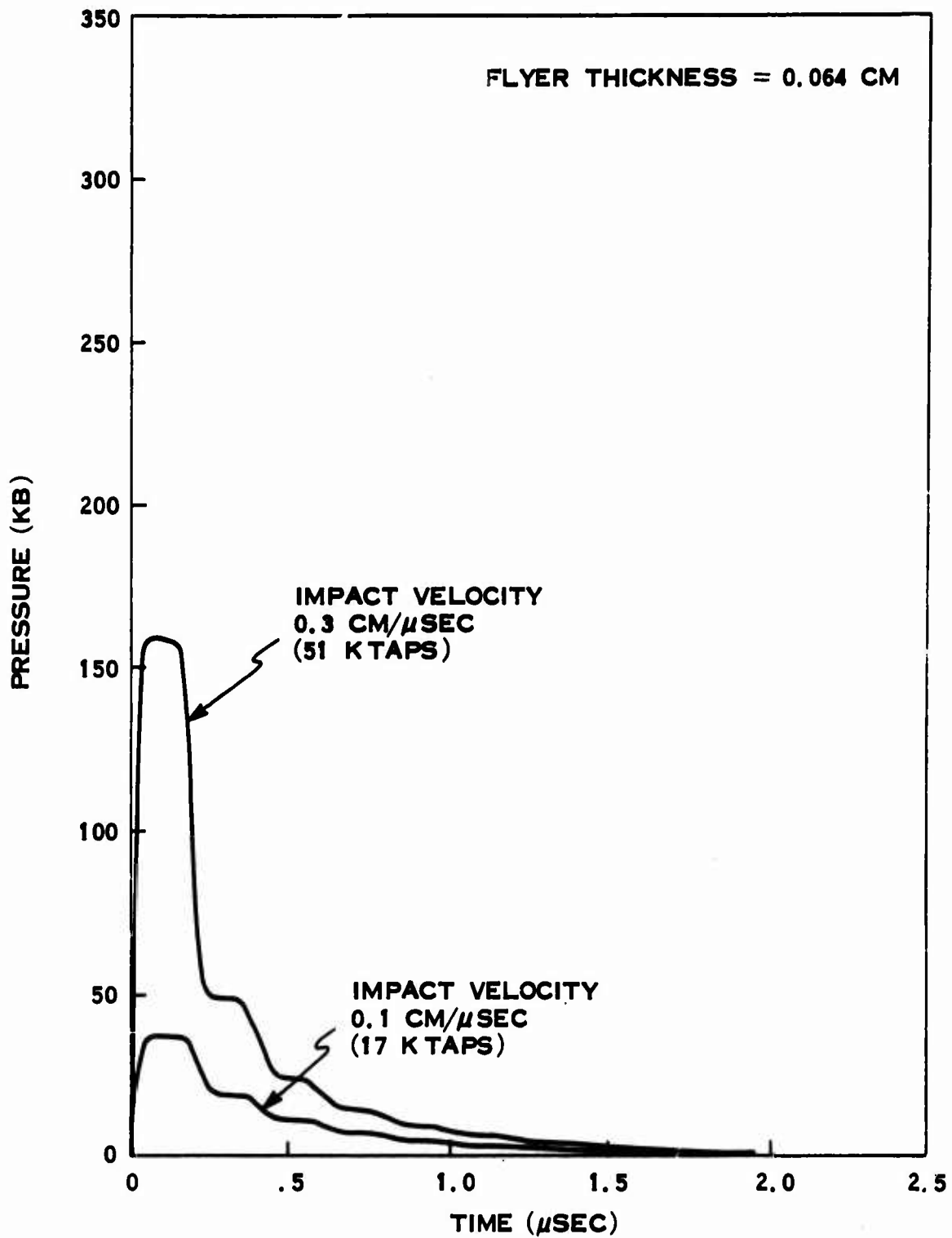

FIGURE 18

PUFF V PREDICTED PRESSURE VS TIME OF ALUMINUM  
FLYER IMPACTING TWNP

flyer plates. The changing of the material at constant tap level changes the pressure by a factor of 3 to 4. Since various thicknesses of various flyer materials are available, magnetically driven flyer plates cover a large portion of the pressure-impulse plane that is of current interest within the defense community. Certainly it appears that common flyer materials and thicknesses can be used to effect pressures in excess of 100 Kb and momentums in excess of 100 Ktaps.

Since most experimental designs call for a free flight flyer, the late time current flow after impact should be minimized. This may be accomplished by a load that is properly matched to the capacitor bank energy (Figure 6) or by such things as exploding foils, nonlinear resistors, or crowbar switches to remove or damp out late time current flow through the load. Development of these techniques is currently in progress<sup>17,24</sup>, and late time current flow does not appear to be a serious problem.

Thus, from a purely technological viewpoint, magnetically driven flyer plates appear to have the capability to produce pressures in excess of 100 Kb and momentums of above  $10^5$  taps with reasonably good control of the desired impact pressure signature. In addition, magnetically driven flyers have proven their ability to produce spatially-varying loads with a reasonable degree of simultaneity.

## 8.0 CONCLUSIONS AND RECOMMENDATIONS

The current technology level of magnetically driven flyer plates is sufficient to produce impact pressures in excess of 100 kilobars and delivered momentums in excess of 100 kilotaps. The lower limit of both pressure and momentum is essentially zero. The width of the pressure pulse is controlled by the thickness of the flyer plate and the relative acoustic impedance of the sample and flyer. Typical pulse widths vary between 0.1 and 1.0  $\mu$ sec and may be extended. The total flyer plate momentum is primarily controlled by the energy source and the geometrical arrangement of the load.

Spatial variations such as a cosine load distribution have been achieved. The total closure time of a flyer impacting a specimen is inversely proportional to the velocity. A flyer velocity of 0.1 cm/ $\mu$ sec could be expected to produce a closure time of approximately 1  $\mu$ sec over a test item of several square feet. Repeatability appears to be 10 percent or less. Shielding and isolation schemes have been developed which allow successful data acquisition of strain, pressure, etc.

Considerable effort has been satisfactorily expended on the predictions of magnetically driven flyer plate behavior. The physics of magnetic pressure are understood to the point of providing reliable flyer plate predictions if the entire system is correctly modeled. Computer codes in existence today correctly model lumped capacitance and electro-explosive sources, but not distributed capacitance systems. Typical system behavior is sufficiently nonlinear so that it defies the applicability of scaling laws over a

wide range of flyer plate loads. Hence, adequate modeling is required for pre-shot prediction. Since the majority of the capacitor banks in the country today utilize capacitors which appear as a distributed constant type of system analogous to a transmission line, a correct energy source modeling is probably warranted.

Very little information exists on the actual physics of the flyer plate-test sample impact. Air cushioning can substantially modify the momentum transfer between the flyer and sample and requires further definition. The phenomena of a temperature dependent equation-of-state and flyer buckling are not understood and have received very little experimental attention. Neither of these two unknowns generates much concern at the present time. In particular, the temperature rise of most practical flyers does not become significant until very high tap levels, at which the details of the flyer equation-of-state are probably of secondary importance.

The flyer buckling question is at best uncertain. The amount of buckling with a given experimental geometry is largely undefined and has not been specifically investigated experimentally. The experimental observations of buckling are mostly by-products of other observations; and, therefore, the ability to discern buckling is marginal. However, most of these observations purport not to observe buckling. Theoretical definition of the effects of buckling on a specimen is also lacking. The lack of both a theoretical and an experimental definition of buckling and buckling effects has created an apathy which may be unwarranted.

Magnetically driven flyer plates appear to be capable of delivering high-level, short-duration, pressure pulses to much larger areas than are now being tested. These flyers offer control of the pressure pulse signature and a high degree of impact simultaneity which are not available with the current method of obtaining high-level, large-area pulses; i.e., the less expensive running loads applied with sheet explosives (SELT). Thus, the justification of additional spending to obtain large magnetically driven flyer plates hinges on the need for simultaneous loads and/or control of the pressure pulse signature. The need must be determined by

- (a) the desire to simulate front surface loads in the laboratory which are available with magnetic flyers but not with SELT; and
- (b) the decision that the response and/or failure of the structure is sensitive to the difference in loading techniques.

At the present time, sufficient data do not exist to examine these differences since no documented evidence exists which compares the response of a structure impacted with a coplanar magnetically driven flyer plate with that of one loaded with SELT. We believe that sufficient doubt and uncertainties exist concerning the response and failure modes of structures subjected to high impulses from the two different stimuli that experimentation is required to determine the difference. Hence, if the desire exists to understand the differences due to stimuli from magnetically driven flyers and SELT, an experimental program needs to be initiated. The test items

would need to be carefully selected so that they represent structural designs of interest (laminar structures, hard points, etc.) and scaled to be compatible in terms of area and impulse currently available with magnetically driven flyer plates. Perhaps two or three structural items could be designed to provide a reasonable spectrum of structural designs of interest, and these should probably be tested at three levels each. Thus, 10 to 20 total tests would probably be required to detail the differences in failure modes and testing techniques. It is not obvious that instrumentation is required.

Electroexplosive systems appear capable of producing large sources of electromagnetic energy for modest costs of expendable items. If high-level, large flyers are required, this technique should be seriously considered.

In summary, the following recommendations are made:

- (a) Air-cushioning effects between the sample and flyer should be defined for those tests which are conducted in the air.
- (b) Additional analytical modeling should be undertaken to allow accurate predictions of capacitor banks not represented by a single lumped capacitance.
- (c) The degree of flyer buckling should be defined for curved flyer experiments.
- (d) Additional experimentation is needed to define the difference in response of structures subjected to high-impulse loads

created by magnetically driven flyer plates and by SELT. Approximately 10 to 20 tests would be required.

**this page intentionally left blank**

## BIBLIOGRAPHY

1. "Magnetically Driven Flyer Plates - Theory and Application", KN-770-68-2(R), T.F. Meagher, March 1968 (Unclassified).
2. "The Influence of Capacitor Bank Parameters on Magnetically Driven Flyer Plates", SLL, D.B. Nelson, December 1967 (Unclassified).
3. "Analog Simulation of a Capacitor Bank Powered Flyer Plate", SC-TM-69-106, E.C. Cnare and J.R. Freeman, SLA, February 1969 (Unclassified).
4. "Analog Simulation of Explosive Current Generators", SC-TM-68-565, J.R. Freeman and E.C. Cnare, SLA, September 1968 (Unclassified).
5. "Numerical Predictions of the Motion of Magnetically Accelerated Flyer Plates", SCL-DR-69-44, R.W. Reynolds and R.S. Jacobson, SLL, July 1969 (Unclassified).
6. "Three Analytical Studies Pertinent to Structural Testing", KN-69-202(R), L.D. Webster, May 1969 (Unclassified).
7. "Theoretical Analysis of Two-Dimensional Magnetic Flyer Plates", KN-69-537(R), L.D. Webster, November 1969 (Unclassified).
8. "Resistance Effects on the Performance of Magnetically Driven Flyer Plates", SCL-DR-69-34, D.B. Nelson, SLL, May 1969 (Unclassified).

## BIBLIOGRAPHY (Cont'd)

9. "A High Energy Shock Facility Using Electromagnetic Energy", SCR-64-84, T.F. Meagher, SLL, August 1964 (Unclassified).
10. "The Calculation of Magnetically Driven Flyer Impacts from Bank Discharge Data Records", KN-70-62(R), A.D. Larrabee, to be published (Unclassified).
11. Private Communication, E.C. Cnare, SLA.
12. "One Dimensional Failure Testing of ATJS Graphite, PTD, and Carbon Phenolic Using Magnetically Driven Flyer Plates (U)", KN-69-679(R), T.F. Meagher, W.C. Hume, and D.C. Williams, December 1969 (Confidential).
13. "One Dimensional Failure Testing of HAAM Materials Using Magnetically Driven Flyer Plates(U)", KN-69-700(R), T.F. Meagher, W.C. Hume, and D.C. Williams, December 1969 (Confidential).
14. "Magnetic Acceleration of Flyer Plates for Shock Wave Testing of Materials", R.S. Jacobson, SLL, September 1967 (Unclassified).
15. "Susceptibility of POLARIS/POSEIDON Reentry Systems to Countermeasures (U)", KN-783-69-46(QPR), E.H. Daus, et al, August 1969 (SRD).
16. "Cosine Shock Loading and Instrumenting a Full-size Reentry Vehicle (U)", SCL-DC-69-18, D.B. Nelson, SLL, April 1969 (SRD).

## BIBLIOGRAPHY (Cont'd)

17. SSPO-sponsored work at Kaman Nuclear.
18. Private Communication, E.O. Williams, SLL.
19. Private Communication, LT Scott Doane, AFWL.
20. "The Use of a Ballistic Pendulum to Determine Imparted Momentum in Magnetically Driven Flyer Plate Testing", R.E. McClellan, Proceedings of the Instrumentation for Nuclear Weapons Effects Simulation, AFSWC, March 12-13, 1970 (Unclassified).
21. The Minutes of the 4th Technical Direction Meeting for the DASA PREDIX Program, Heliodyne Report #SD-633, D. Keller, ETI, July 1969 (SRD).
22. "Susceptibility of POLARIS/POSEIDON Reentry Systems to Countermeasures, Annual Progress Report #12 (U)", KN-808-70-48(APR), E.H. Daus, et al, February 1970 (SRD).
23. "PUFF V-EP Code, Parts I and II (U)", KN-703-67-101(R), L.E. Bothell and C.E. Archuleta, December 1967 (SRD).
24. Private Communication, Alexander Florence, SRI.

**this page intentionally left blank**

**APPENDIX A**

The agencies listed below were visited in conjunction with this project. The listed contacts represent an individual from each of the major areas visited within the agencies; however, several additional people within those areas made major contributions. The asterisk (\*) indicates those companies that are actively participating in magnetically driven flyer plates.

<u>AGENCY</u>	<u>LOCATION</u>	<u>CONTACT</u>
Sandia Laboratories* Livermore	Livermore, California	S. Cain W. Zinke
Stanford Research Institute*	Stanford, California	H. Lindberg
Effects Technology, Inc.	Santa Barbara, California	D. Keller
McDonnell-Douglas Astronautics Co.	Santa Monica, California	H. Berkowitz J. Peck
Maxwell Laboratories, Inc.	San Diego, California	R. O'Rourke R. Fitch
Air Force Weapons Laboratory*	Albuquerque, New Mexico	LT R. Schapaugh
Sandia Laboratories* Albuquerque	Albuquerque, New Mexico	D. McClosky W. Alzheimer F. Mathews
Ion Physics Corporation*	Bedford, Massachusetts	J. Farber
EG&G*	Bedford, Mass.	J. Chapman
AVCO	Wilmington, Mass.	J. Olson
DASA Headquarters	Arlington, Va.	MAJ D. Shover

**UNCLASSIFIED**

Security Classification

**DOCUMENT CONTROL DATA - R & D**

(Security classification of title, body of abstract and indexing annotation must be entered when the original report is classified)

1. ORIGINATING ACTIVITY (Corporate author) Kaman Nuclear, A Division of Kaman Sciences Corporation 1700 Garden of the Gods Road Colorado Springs, Colorado 80907		2a. REPORT SECURITY CLASSIFICATION <b>Unclassified</b>	
3. REPORT TITLE <b>THE THEORY AND CAPABILITIES OF MAGNETICALLY DRIVEN FLYERS</b>		2b. GROUP --	
4. DESCRIPTIVE NOTES (Type of report and inclusive dates) <b>Topical report</b>			
6. AUTHOR(S) (First name, middle initial, last name) Thomas F. V. Meagher David C. Williams			
5. REPORT DATE <b>January 30, 1970</b>	7a. TOTAL NO. OF PAGES <b>59</b>	7b. NO. OF REFS <b>24</b>	
8a. CONTRACT OR GRANT NO. <b>DASA-01-68-C-0084</b>	8b. ORIGINATOR'S REPORT NUMBER(S) <b>KN-770-70-35(R)</b>		
8c. PROJECT NO. <b>NWER XAX Subtask AC 301</b>	8d. OTHER REPORT NO(S) (Any other numbers that may be assigned this report) <b>DASA 2440</b>		
8e. Task and Subtask <b>c 301</b>			
8f. Work Unit <b>01</b>			
10. DISTRIBUTION STATEMENT <b>This document has been approved for public release and sale; its distribution is unlimited.</b>			
11. SUPPLEMENTARY NOTES		12. SPONSORING MILITARY ACTIVITY <b>Director Defense Atomic Support Agency Washington, D.C. 20305</b>	
13. ABSTRACT The basic theory governing the behavior of magnetically driven flyer plates is derived and discussed. Analytical tools capable of predicting the non-linear response of flyer plate systems are described and one such tool is utilized to predict the behavior of a typical capacitor bank-magnetically driven flyer plate facility. Practical applications and achievements, including instrumentation and bank diagnostics, of operating systems are described. Consideration is given to uncertainties arising from a lack of definition of (1) the cushioning (air or magnetic) between the sample and flyer, (2) the thermodynamic condition of the flyer at impact, and (3) the degree of buckling of a curved flyer at impact with a curved test specimen. Particular attention is given to the high impulse capability of magnetically driven flyer plates. Theoretical predictions of the temperature rise in various materials due to I <sup>2</sup> R heating are presented along with hydrodynamic calculations of the pressure-time history resulting from magnetically driven flyer plate impacts on tape wound nylon phenolic. Included in the summary is a discussion of the need for magnetically driven flyer plate loadings of structural items.			

10. KEY WORDS	LINK A		LINK B		LINK C	
	ROLE	WT	ROLE	WT	ROLE	WT
<b>Magnetically Driven Flyers</b> <b>Basic theory of</b> <b>Applications of</b> <b>Capacitor Banks</b> <b>Structural Loadings</b>						