

AD709703

THE STUDY OF THE INTERACTION OF
INTENSE PICOSECOND LIGHT PULSE WITH
MATERIALS

A QUARTERLY TECHNICAL REPORT



UNIVERSITY OF MARYLAND
DEPARTMENT OF
ELECTRICAL ENGINEERING

COLLEGE PARK, MARYLAND

20742

Reproduced by the
CLEARINGHOUSE
for Federal Scientific & Technical
Information Springfield Va. 22151

DDC
RECORDED
AUG 3 1970
ALBERT
B

**BEST
AVAILABLE COPY**

THE STUDY OF THE INTERACTION OF
INTENSE PICOSECOND LIGHT PULSE WITH
MATERIALS

A QUARTERLY TECHNICAL REPORT

SUBMITTED TO
THE U. S. ARMY RESEARCH OFFICE

PERIOD

MARCH 18, 1970 to JUNE 18, 1970

REPORTED BY

CHI H. LEE

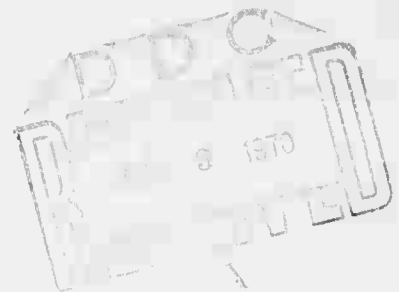

Quarterly Technical Report

For

Period March 18, 1970 to June 18, 1970

Submitted to the U.S. Army Research Office

ARPA Order Number	675, Am. 7
Program Code Number:	9E20
Name of Grantee:	University of Maryland
Effective Date of Grant:	December 18., 1969
Grant Expiration Date:	December 19, 1970
Amount of Grant:	\$30,000
Principal Investigator and Phone Number	Dr. Chi H. Lee (301) 454-2443
Grant Number:	DA-ARO(D)-31-124-70-G50
Project Scientist or Engineer	None
Short Title of Work:	"The Study of the Interaction of Intense Picosecond Light Pulse with Materials"

Reported by:

Chi-Hung Lee

Dr. Chi H. Lee
Assistant Professor

1. INTRODUCTION AND SUMMARY

In this reporting period, we continue with the study of two-photon photoconductivity effect. In addition to this, a new program has been initiated, i. e., the investigation of the two-photon optically pumped semiconductor bulk laser. The interest in the two-photon photoconductivity effect lies on the fact that this provides a new method for measuring picosecond pulse. Up to now, all the short pulse measurements have been photoemissive detection using either a photomultiplier⁽¹⁾ or a photography plate⁽²⁾. The photoconductive detector can also be used for this purpose and it can be made in a form of multilayer device. Thus a multichannel recording of the data in a single laser firing is possible. A suitable material as a two-photon photoconductor is GaAs. It has a band gap of 1.5eV and the mode-locking Nd:glass laser beam has photon energy of 1.17 eV. The condition

$$2\hbar\omega > E_g > \hbar\omega \quad (1)$$

is satisfied. In this case the interband transition involves only two-photon process. The free carriers excited to the conduction band will change the conductivity of the material. When recombination takes place, there is also fluorescence emission as a result of the two-photon absorption. If one puts a thin slice of GaAs in the path of the crossed laser beams as shown in Fig. 1, one will obtain conductivity change of the sample due to two-photon absorption. If the laser output consists of a train of picosecond pulses, the conductivity change will be maximum when the sample is placed at the position where the two oppositely directing beams have their pulses overlap. This method is essentially just a variation of the two-photon fluorescence technique⁽²⁾ and the recently reported third harmonic measurement of the picosecond pulses⁽³⁾. They all measure the correlation function of intensity. In all these methods in order to obtain a good agreement between theoretical prediction and the experimental observation, one requires a thin nonlinear element and needs

FIG. 1

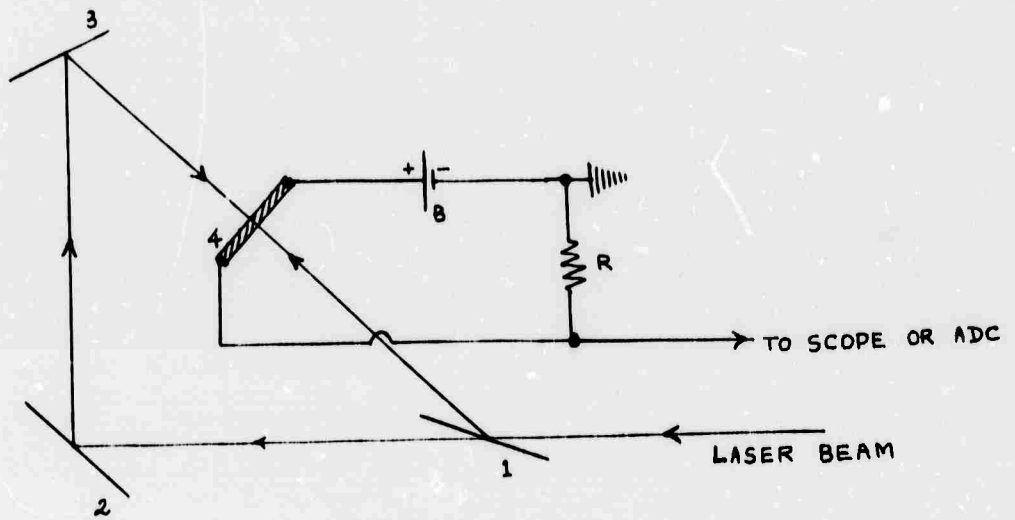

- 1. Beam splitter
- 2,3. Mirrors
- 4. Ga As Crystal
- B. Battery
- R. Resistance

many laser firings to complete the time variation plot of the intensity correlation function. Thus, it is desirable to obtain all the information in a single laser firing. The two-photon photoconductivity effect will have the potential application for this purpose. Because, in principle, one can construct a multilayer two-photon photoconductive thin film device. Each layer will record the intensity correlation at its particular position. In conjunction with a multichannel analyzer one will have data of intensity correlation function at various positions in a single laser firing. The technology of thin film and integrated electronics has advanced to a point that such a device is feasible to construct. The electrical engineering department of the University of Maryland has recently set up a complete integrated circuit laboratory with various vacuum evaporators available. Thus we have the facility to make the device if such an effect is proven to be workable. We, therefore, have begun our experimental investigation of the two-photon photoconductivity effect by using the output of the dye Q-switched Nd:glass laser as excitation source. In this reporting period, more quantitative measurements have been performed. We have measured the two-photon absorption coefficient β and determined it to be 5.0CM/MW in good agreement with the data obtained by Basov, et al⁽⁴⁾. Photoconductivity of the GaAs sample has also been measured for the radiation laser intensity of one kilowatts/cm² to a few megawatts/cm² range. It was found that at laser intensity below 1 MW/cm², single-photon absorption from the impurity level is predominant. Two-photon absorption effect takes over at laser power density of 1 MW/cm². This result is consistent with the measured single-photon and double-photon absorption coefficient made on the very same sample. The observed data is compared with the theoretical calculation based on Yee's paper⁽⁵⁾. We obtain a good agreement in the slope of the conductivity vs laser power density curve while the absolute magnitude of the conductivity change is about one order of magnitude too small for the experimental case. A program is planned to extend the laser power density to high value and to obtain a thinner sample for conductivity measurement.

The detail experimental technique and results will be discussed in the next section.

Another important application of the two-photon absorption effect is to use it as a means for optically pumped bulk semiconductor lasers. Basov, et al⁽⁶⁾, and more recently Chang and Wang⁽⁷⁾ have demonstrated that such a pumping scheme is workable. They have achieved bulk laser action in GaAs and Cds crystals via two-photon absorption of Nd:glass and ruby laser photon respectively. The advantage of two-photon pumped semiconductor lasers over the injection lasers lies on the fact that in the former case it is possible to uniformly pump the entire volume of the lasing medium while in the latter case lasing action is confined to the junction. Thus, in principle, high power semiconductor lasers are possible only in the bulk case. With the advent of the mode-locked laser⁽⁸⁾ it is possible to use it to pump a semiconductor bulk laser to achieve picosecond pulses from the semiconductor laser. With proper temperature tuning it is even possible to obtain a tunable picosecond light source. Motivated by these ideas, we have started a research program to study the mode-locked semiconductor laser. In addition to myself, there are Dr. S Siahatgar and a graduate student participating in this program. In this reporting period we have obtained a GaAs single crystal of $10 \times 5 \times 4^{\text{mm}}$ with two end faces antireflecting coated. We have designed and constructed a Dewar to cool the sample. We choose to study the problem in a more systematic way by starting with the study of the two-photon absorption and fluorescence characteristics of the GaAs sample. Preliminary data showing a pronounced spectral narrowing of the fluorescence spectrum suggested that a condition for stimulated emission is being approached. The experimental arrangement and preliminary result will be represented in section III.

In section IV, we shall discuss an initiative effort of investigation of nonlinear total reflection phenomenon⁽⁹⁾ with picosecond pulses. Such an

effect will also provide an alternative method for the picosecond pulse width measurement which can be used as an independent check on the recent method of third harmonic picosecond pulse measurement⁽³⁾. In addition to this practical application, some of the law for nonlinear total reflection may be extended to third order nonlinearity⁽¹⁰⁾. In particular, one may obtain valuable information of the phase change of the harmonic wave occurring at total internal reflection⁽¹⁰⁾. We have begun some preliminary calculations of the critical angle for total internal reflection. The difficulty is associated with the fact that there is limited data on index of refraction for the dye Fuchsin red in H₂O which is selected as our sample as nonlinear element. Initial experimental plans have been laid out. Test of third harmonic generation from this dye has been performed in transmission and this will be used as a calibration of our technique.

II. TWO-PHOTON CONDUCTIVITY IN GALLIUM ARSENIDE

(1) Introduction and theoretical background.

The advent of intense lasers has made it experimentally feasible to observe a number of intensity dependent optical interactions in matter which involves two or more photons. One of the methods of studying the multiphoton absorption in condensed media is to observe the conductivity change of the sample due to intense optical excitation which induces more charge carriers in the medium. The present experiment is planned to investigate the two-photon induced conductivity in GaAs using a dye Q-switched Nd:glass laser. Such an experiment will yield valuable information about the impurity levels, recombination mechanism and the behavior of non-equilibrium charge carriers in the semiconductor. Gallium

Arsenide is chosen because it is a direct band-gap material whose forbidden energy gap is 1.41 eV. The Q-switched neodymium-glass laser is used because its beams have photon energy of 1.17 eV. Thus the change of conductivity is expected to be a two-photon absorption. Before we discuss the experiment, we shall first outline the theory developed recently by Basov⁽⁶⁾ and Yee⁽⁵⁾. This will serve as the groundwork of our study.

The photoconductivity produced in direct bandgap semiconductors by the two-photon absorption process was investigated theoretically by J. H. Yee⁽⁵⁾ and the theory was applied to GaAs. In a single photon absorption process, the absorption coefficient α is independent of the intensity of light. For the case where the charge carriers are generated by the two-photon absorption, the absorption coefficient θ is linearly dependent on light intensity

$$\theta = 2\hbar\omega A_0 I \quad (2)$$

where $2\hbar\omega = 2.34 \text{ eV}$ for the Nd:glass laser beam and I is the intensity of the laser. Basov et al⁽⁶⁾ have derived the expression for the constant A_0

$$A_0 = \frac{2^{17/2} \pi^4 c^4}{\epsilon c^2 (\hbar\omega)^6} (2\hbar\omega - E_g)^{3/2} \times \left[\frac{|\langle \alpha \cdot p \rangle|^2}{m^2} m_{cv_1}^2 + \frac{|\langle \alpha \cdot p \rangle|^2}{m^2} m_{cv_2}^2 \right] \quad (3)$$

where $h\omega$ is the photon energy, E_g the band gap and the subscripts c , v_1 and v_2 denoting conduction, valence bands respectively. For GaAs, β can be calculated using the band parameters.

$$K = \frac{\beta}{I} = 2h\omega A \quad (4)$$

is found to be 6.05 cm/MW for the sample which was used in this experiment. The calculation is carried out in Appendix I.

Basov et al⁽⁶⁾ derive for the intensity of light through a thickness "x" cm of the crystal

$$I_x = I_0 (1 + 2h\omega A_0 I_0 x)^{-1} \quad (5)$$

using the band structure of GaAs as shown in Fig. 2a. The generation rate of charge carriers in this type of crystal as a result of two photon absorption can then be written as

$$F(x) = A_0 I^2 \quad (6)$$

The concentration of generated carriers obey the following differential equation

$$D_p \frac{\partial^2 p}{\partial x^2} - \frac{p}{\tau} = -F(x). \quad (7)$$

J. H. Yee⁽⁵⁾ solved this equation by the method of variation of parameters to obtain the two photon conductivity as

FIG. 2 a.

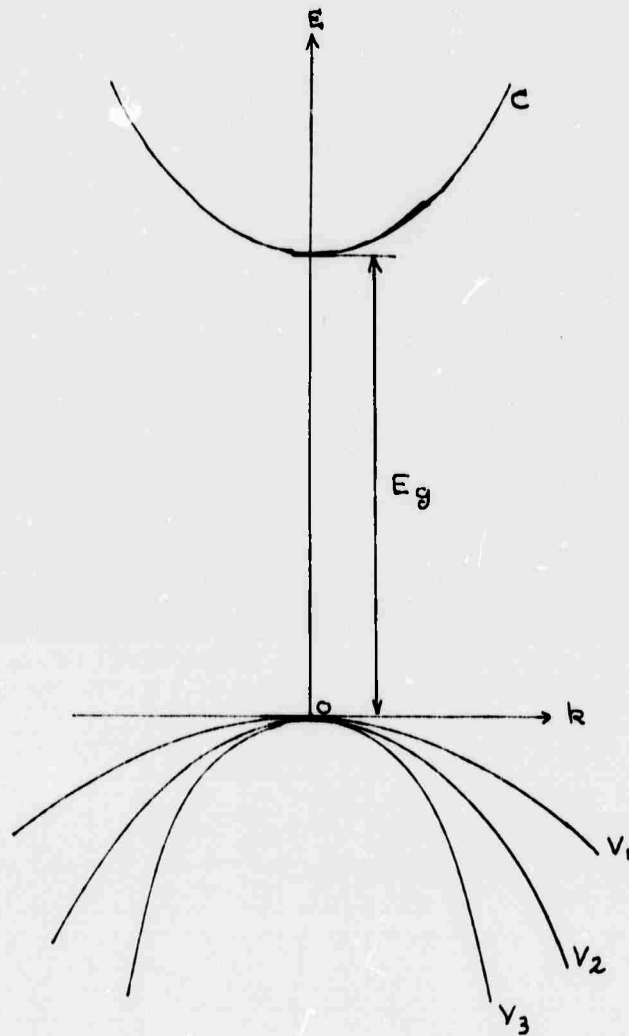

GaAs BAND STRUCTURE

C. Conduction band.

V₁, V₂, V₃. valence bands.

$$\Delta G = \frac{\alpha I_0^2 L A_0}{D \lambda^2 (1 + \beta L)} - \frac{2 V_S I_0^2 A_0 \alpha e^{-\lambda L/2}}{D \lambda^2 [(\lambda + V_S) - (\lambda - V_S) e^{-\lambda L}]} \times \int_0^L \frac{\cosh\left(\frac{\lambda L}{2} - x\right)}{(1 + \beta x)^2} dx \quad (8)$$

$$\text{where } \alpha = \frac{c}{a} q(\mu_c + \mu_h), \quad \lambda = (D_p \tau)^{-\frac{1}{2}} \quad (9)$$

$\beta = 2h\omega A_0 I_0$, I_0 = incident light intensity.

$c \times a \times L$ crystal dimensions. μ_e, μ_h - electron, hole mobilities

λ = inverse of diffusion length. q_v - electronic charge.

D - Diffusion length

$V_s = V_5/D$ = Recombination velocity at surface

Our immediate objective is to measure the two-photon conductivity in GaAs and compare this measured value with the theoretical value given in Eq. (8).

(2) Experiments

The experimental set up is shown in Fig. 2b. A dye Q-Switched neodymium glass laser was used to provide the exciting light beam. Corning glass filter 2-64 was placed on a window of a black box which contained the entire laser so that only the 1.06μ laser beam illuminated the sample not the pumped flash light. Part of the laser beam was deflected by a glass slide to incident on a photodiode which monitor the laser power in each laser firing. This procedure was necessary because the laser output fluctuated from shot to shot. The main beam illuminated the GaAs crystal connected to a battery via a $3 K\Omega$ variable resistor. The

FIG. 2. b

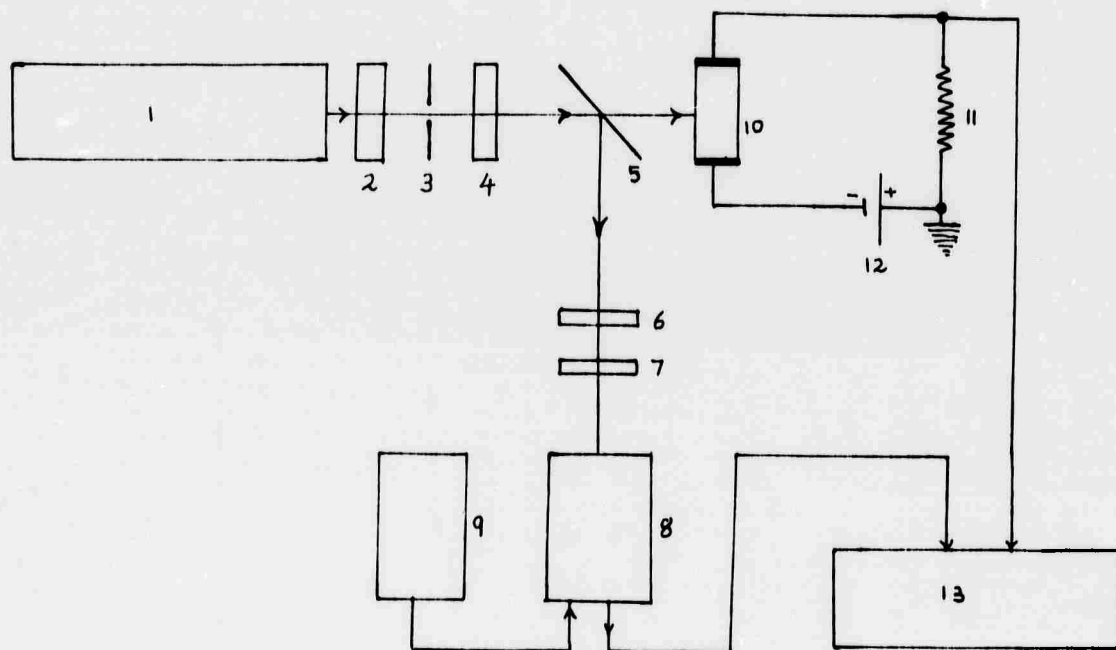

- | | |
|---|--|
| 1. Nd-glass laser in light tight Box (dye @-switched) | 10. Ga As Crystal |
| 2. Flash lamp filter. | 11. Variable resistance (0-3k Ω) |
| 3. Beam limiting aperture | 12. Battery |
| 4,6 ND filters. | 13. Dual beam oscilloscope. |
| 5. Beam Splitter | |
| 7. Ground glass. | |
| 8. ITT Photo diode | |
| 9. EHT 2000 volts (+ve) | |

The sample was n-type doped with O_2 with concentration of $5.2 \times 10^{14} / \text{cm}^3$. The thickness of the sample was measured to be 0.028 cm. The sample as shown in Fig. 2 b was simply a conductive element in the circuit. With no illumination there always exists a dc current in the loop. Under the illumination of a laser beam the conductivity of the GaAs sample changed as a result of two-photon absorption. This change in turn caused a change of magnitude of the current which was circulating in the circuit. The change was monitored as a ac voltage across the variable resistor (which was set at a particular value for a particular measurement) and was displayed in one channel of a dual beam oscilloscope. The laser pulse detected by the photodiode was displayed in the other channel. The signal due to change of conductivity should be in time correlation with the laser pulse. This was indeed observed and was regarded as one of the signature of the effect. Another experimental evidence one should like to establish is to make sure that the signal is not due to photovoltaic effect. This can be done by simply replacing the battery by a conducting wire. If no signal is observed by so doing one can establish that the signal detected is not due to photovoltaic effect. This point was also checked in our experiment. Finally it remained to measure the photoconductivity for a wide range of laser power. However the photoconductivity was not a direct quantity that we measured. What we measured was the change of the voltage across the series resistor due to the change of the conductivity in the sample. Owing to the fact that not the entire sample was uniformly illuminated by the laser beam, one has to calculate the conductivity

change from the measured change of voltage on the oscilloscope. This calculation is not trivial and is outlined in Appendix II. We avoided to illuminate the ohmic contact portion of the sample to insure that there was no photovoltaic effect. Using the technique just described, we have measured the conductivity change for laser power ranged from kilowatts/cm² to a few megawatts/cm². The result of the measurement will be discussed later.

(3) Absorption Coefficient Measurement

To insure that the observed conductivity change was indeed a consequence of the two-photon absorption process, it was necessary to measure the single photon and two-photon absorption coefficients for the sample we used. The dependence of the intensity of light transmitted by GaAs on the intensity of the incident light was used to estimate the single photon and double photon absorption coefficients. (11, 12, 13) The intensity of light $I(x)$ at a depth "x" of the crystal is written as

$$\frac{d I(x)}{dx} = -\alpha I(x) - K I^2(x) \quad (10)$$

where α is the single photon absorption coefficient in cm⁻¹ and K is the two-photon absorption coefficient in cm/MW and

$$K = 2h\omega A_0 = \frac{\beta}{I} \quad (11)$$

The solution of the equation is of the form

$$I(x) = \frac{I_s e^{-\alpha x}}{1 + \frac{2h\omega A_0}{\alpha} I_s (1 - e^{-\alpha x})} \quad (12)$$

I_s is the incident light intensity just inside the crystal surface. If R is the reflection coefficient for normal incidence

$$\frac{I_o}{I_x} = \frac{e^{\alpha x}}{(1-R)^2} + \frac{(e^{\alpha x} - 1)}{(1-R)} \frac{K}{\alpha} I_o \quad (13)$$

where I_o is the incident light intensity just outside the crystal surface and I_x is the transmitted intensity. From the measurement of I_x as a function of I_o we can plot $\frac{I_o}{I_x}$ vs I_o which is a straight line according to Eq. (13). The y-intercept of this straight line will determine the value α while the slope of the line determines the two-photon absorption coefficient K .

The experimental set up for the measurement of I_o and I_x was similar to the one indicated in Fig. 2 b except that in the present experiment, the transmitted intensity was monitored by another photodiode. Fig. 3 shows the data points of I_o/I_x against I_o . A least square straight line fit was computed to the data points and is also shown in the figure. Knowing the R and X , the thickness of the crystal, we determined the α value to be 2.41 cm^{-1} from the y-intercept in Fig. 3. From the slope of the curve, the value of $K = 2\hbar\omega A_o = \frac{\beta}{I}$ was determined⁽¹¹⁾ to be about 5.5 cm/MW . This value agrees fairly well with the computed value of 6.05 cm/MW ⁽⁴⁾. However, the value for K reported in reference (13) is 1000 times smaller than our experimental determination.

FIG. 3

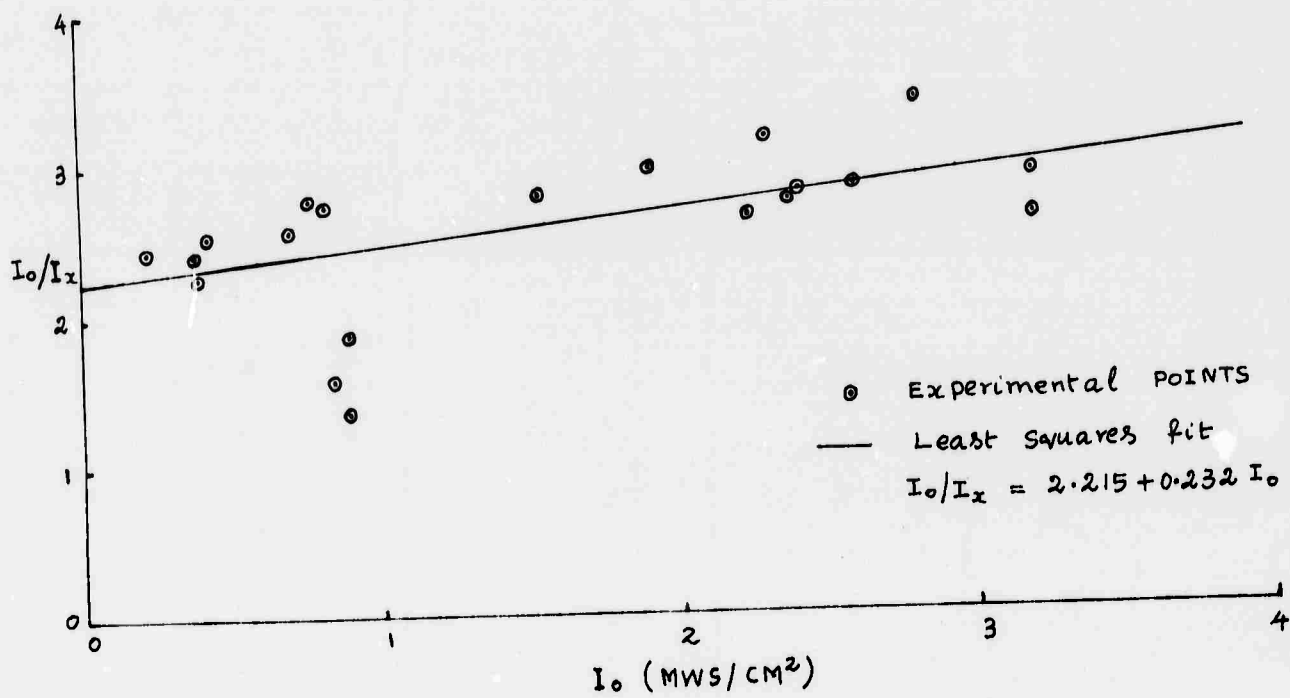

(4) Experimental results and discussion

The experimental value of the conductivity change was determined for a wide range of laser power density (Watts/cm^2). First the power density of the Q-switched laser beam must be accurately determined. The variations of the laser intensity was achieved by introducing various neutral density filters. The photodiode was then calibrated against the thermopile and the width of the pulse was measured by the oscilloscope trace. The conducting change was calculated by the method presented in Appendix II from the measured voltage change on the scope. The result is shown in Fig. 4 which is a plot of the log photoconductivity versus log laser power density for power density less than 2MW/cm^2 region. A least square fit to the data points gave a slope of 0.81, indicating that the process was one of single photon absorption for such low intensity regions. A separated run to cover 0.2 to 4MW/cm^2 intensity range was then made. At high laser intensity one observed saturation of the voltage change due to the large increase of the photoconductivity. To minimize the saturation effect we used a small value (55Ω) series resistor in the circuit. The reason of saturation is discussed in Appendix II. Again a plot of log conductivity versus log laser power density is shown in Fig. 5 in the range of 0.2MW/cm^2 to 4MW/cm^2 . From the graph one can clearly see a change of the slope of the curve near 1MW/cm^2 , of laser intensity. Above 1MW/cm^2 , the data points fit into a line of slope 1.7 and below this intensity level of a slope of 0.8. This together with the data on Fig. 4 shows that the single photon process plays

FIG. 4

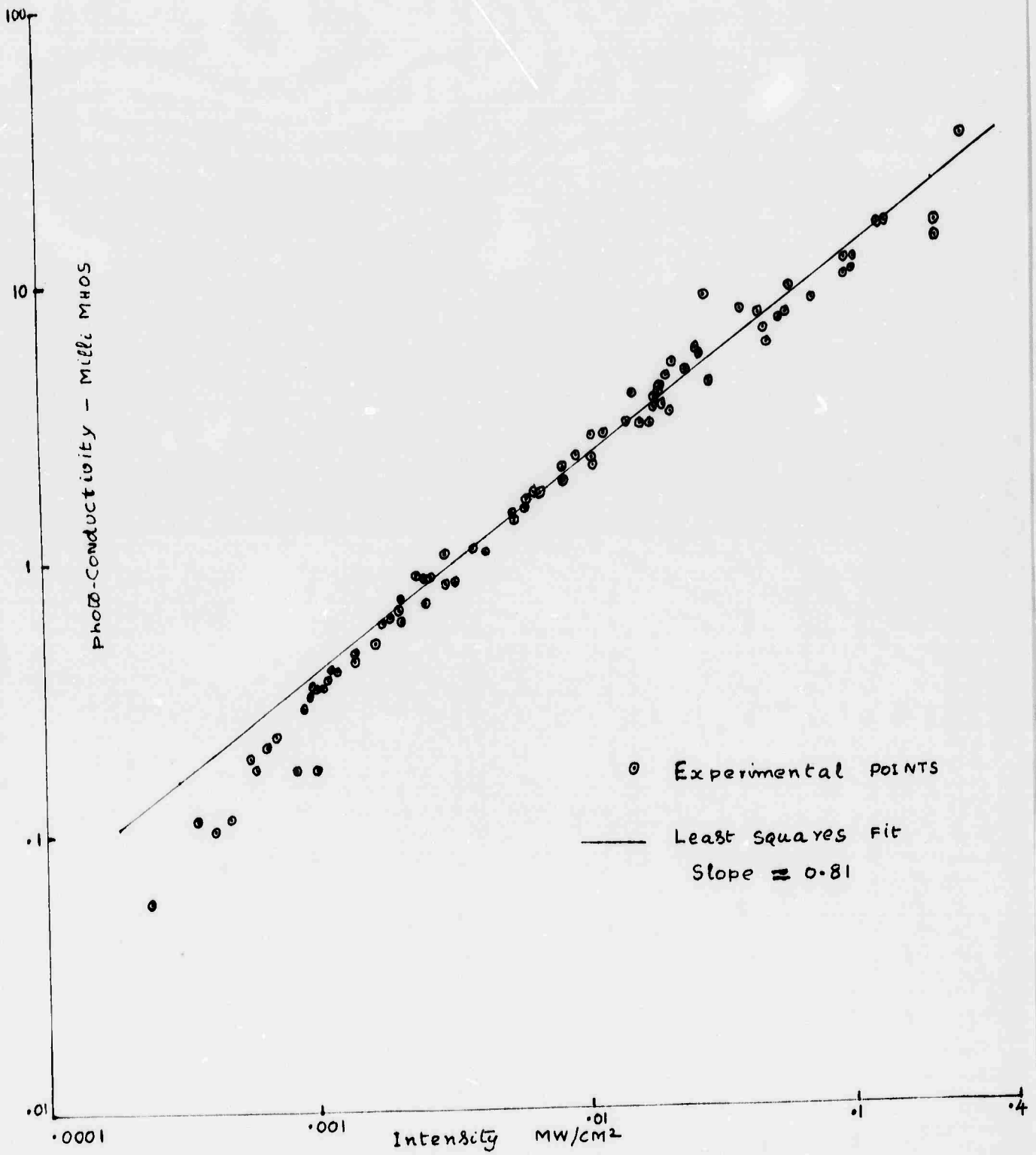
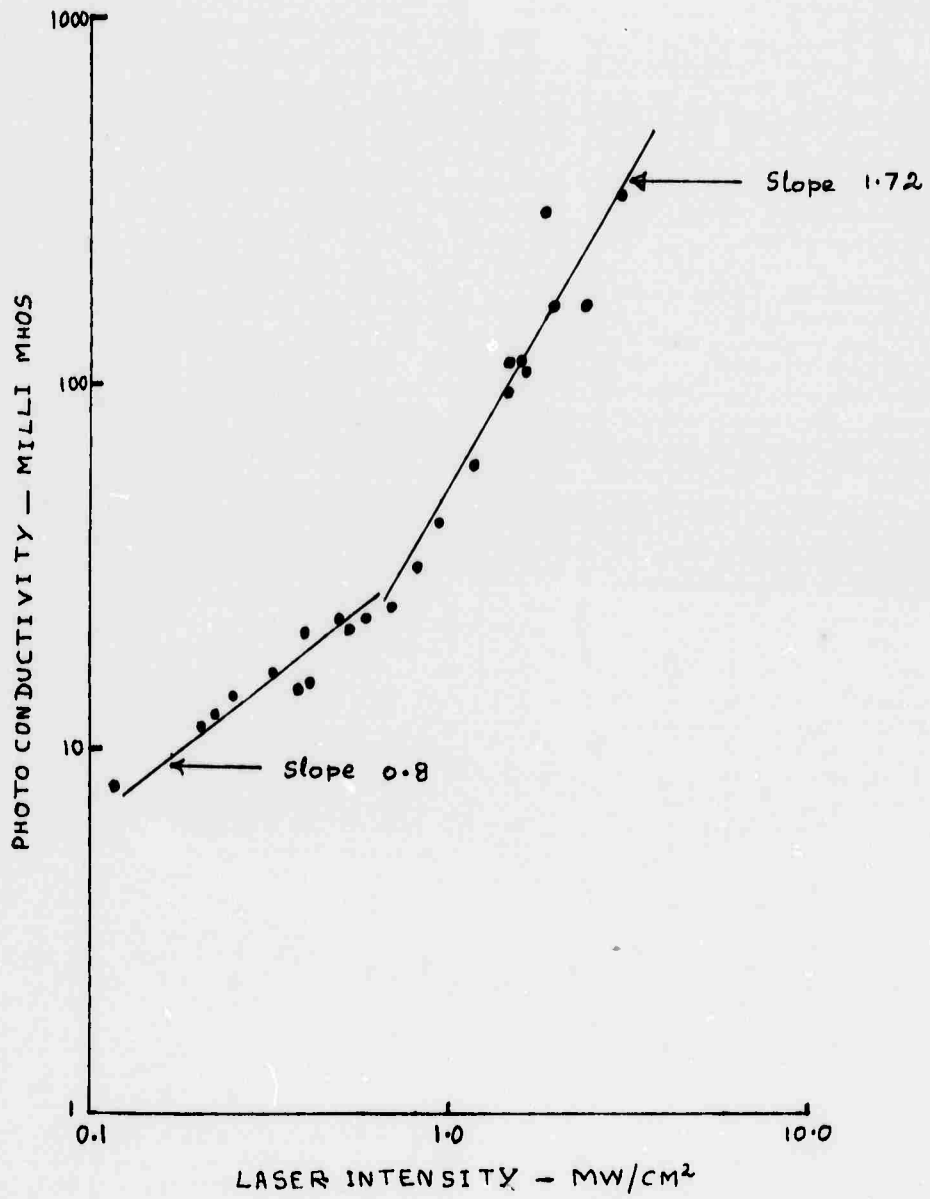

FIG. 5



the dominant role in producing charge carriers below 1 MW/cm^2 and above that level the two-photon absorption process dominates. This observation is in consistency with the experimentally determined values of α and β . At 1 MW/cm^2 , $\beta = 5.5 \text{ cm}^{-1}$ and $\alpha = 2.4 \text{ cm}^{-1}$. Above this intensity, β increases linearly with laser intensity yielding a line of slope near to 2.

The slightly higher absolute value of conductivity in the case of points taken from the previous run (Fig. 4) may be due to the fact that the experiments were done at different times leading to inaccuracies in the intensity calibration.

Yee's theoretical curve is plotted in Fig. 6 for our sample by assuming the following parameters:

$$\frac{c}{a} = \frac{1}{3}$$

$$\tau = \text{lifetime of carriers} = 10^{-7} \text{ sec}$$

$$K = \frac{\beta}{I} = 5.0 \text{ cm}^2/\text{MW}$$

$$L = 0.028 \text{ cm}$$

$$v_g = 1.3 \times 10^3$$

$$\lambda = 78$$

$$\lambda L = 2.18$$

The intensity of the laser cover 1 KW/cm^2 to 10 MW/cm^2 region. This curve is plotted under the assumption that only pure two-photon absorption is involved. The theoretical predicted slope of 2 for laser power density less than

FIG. 6

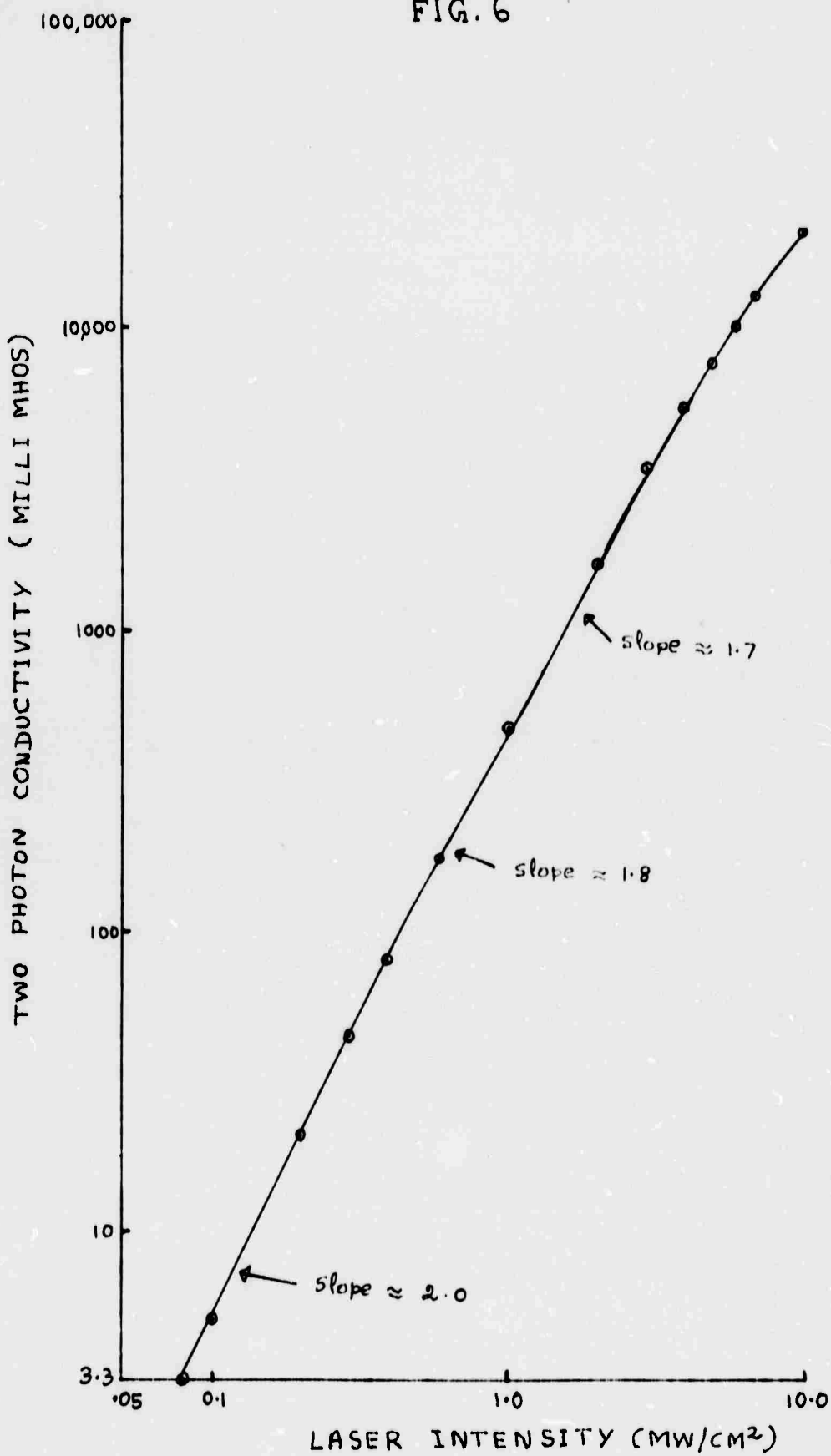

1 MW/cm^2 can not be observed in our experiment because the one-photon absorption predominates in this range. It is interesting to note that at laser power density from 1 MW/cm^2 to 10 MW/cm^2 the slope is about 1.8 in fairly good agreement with the experimental observation. The absolute magnitude of the conductivity however is about one order of magnitude larger in the theoretically case. This may be due to the fact that the lifetime and surface recombination velocity assumed in the calculations are different from what they ought to be. For higher laser intensity, the slope start to decrease again. This is probably due to recombination process dominating the two-photon absorption. It is learned from both theoretical considerations and experimental observations that the two-photon induced photoconductivity change can only be observed in a limited power range with a slope near to 2 for our present sample. In the future experimental program we will seek for another kind of material which has large band gap than that of the GaAs. Also it is clear that thinner samples are needed to extend the slope 2 region so that the application of this effect for picosecond pulse measurement may be meaningful.

III. TWO-PHOTON PUMPED BULK SEMICONDUCTOR LASER

The work of Basov^(4, 6) and recently reported work of Wang and Chang⁽⁷⁾ have shown that it is possible to achieve laser action in semiconductor bulk material by using two-photon absorption as the pumping mechanism. With the advent of mode-locked laser, this pumping scheme may be extended to obtain the ultrashort pulses from the semiconductor. In this experiment we have chosen GaAs single crystal as the lasing medium and Q-switched

Nd:glass laser as the pumping source. The crystal was purchased from Semi-Elements, Inc. with its specification and orientation shown as in Fig. 7. Two end faces of 4×5 mm are antireflection coated for 8000 Å to 9000 Å wavelength region since our purpose is to achieve laser action with external resonant reflectors. For the present experiment of two-photon fluorescence study we sent Nd:glass laser beam through face ABCD (referred to Fig. 7). The experimental set up is shown in Fig. 8. The monochromator had a working wavelength range to cover 1.06μ and all the way down to visible. We used the Nd:glass emission to calibrate the wavelength drive of the monochromator and to test its blocking ability. The filters inserted in the path were used to block to 1.06μ when the fluorescence spectrum was recording. To take into account of the shot to shot fluctuation of the Q-switched laser performance we used a photodiode to monitor the laser power. The fluorescence signal detected by the photomultiplier was normalized with respect to the monitor signal for each laser firing. The result of the two-photon fluorescence spectrum was shown in Fig. 9. Two curves are shown in Fig. 9 for different incident laser power density. The variation of laser power density was achieved by properly arranging the lens system. Curve II was obtained with laser power density about double that of curve I. Clearly there shows a significant spectral narrowing when the incident power density is increased. This fact is a good indication that stimulated emission is possible in this crystal. The crystal was kept at 77°K . The center of the emission spectrum is shown to be at 8400 \AA . The present geometry is collinear pumping. There is no reason why one cannot have 90° pumping. Works are in plan now including the study of two-photon fluorescence spectrum with even higher laser power density. An attempt to introduce external reflectors is also planned.

IV. THIRD HARMONIC GENERATION AT TOTAL REFLECTION WITH PROSECOND PULSES

The theory of the parametric generation of light at the boundary of a nonlinear medium ⁽¹⁴⁾ has been verified experimentally for a variety of geometrical situations ⁽¹⁵⁾. One important aspect of the theory is concerned

The specification and the orientation of the GaAs crystal specification

- (1) n-type GaAs single crystal
- (2) dimensions: 4mm x 5mm x 10mm
- (3) dopant: any dopant will do.
- (4) carrier concentration: in the vicinity of $2 \times 10^{17}/\text{cm}^3$
- (5) mobility 4000 $\text{cm}^2/\text{v-sec}$
- (6) orientation: see the drawing:

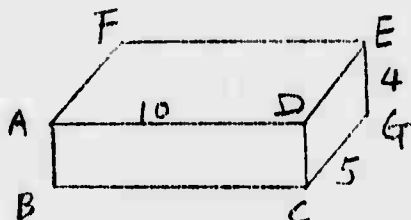

AD = 10mm
EG = 4mm
CG = 5mm

- (a) The normal of the ABCD face is along (1,1,0) axis of the crystal.
 - (b) The BC edge is along (-1,1,0) axis of the crystal.
 - (c) The BA edge is along (0,0,1) axis of the crystal.
- (7) Polishing: Optical polishing on all faces, with particular emphasis on the two 4 x 5 end faces. Please specify how well you can polish- in term of the fraction of optical wave length at the price you quoted.
 - (8) Coating: Broad band anti-reflection coating on two 4 x 5 end faces and one of the (1,1,0) face, (i.e., ABCD face shown in the figure, the wave length ranges from 8200Å to 1.1μ for reflectivity less than 1%).

Fig 7

FIG. 8

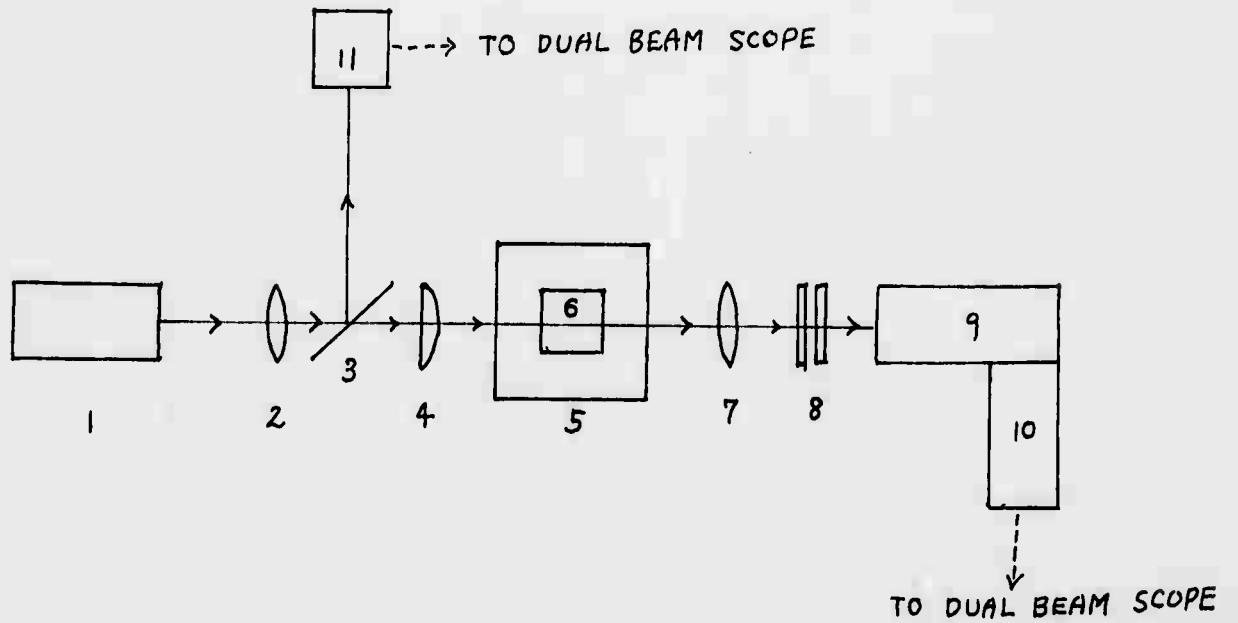

1. Nd - GLASS LASER
2. LENS
3. BEAM SPLITTER
4. CYLINDRICAL LENS
5. DEWAR
6. GaAs SAMPLE
7. COLLECTING LENS
8. FILTERS
9. MONOCHROMATOR
10. PHOTOMULTIPLIER (RCA 9102)
11. PHOTODIODE

Fig. 9

Fluorescence of GaAs sample at 77°K
Wave length range 0.8 to 0.9 μ
Entrance slit of 1 mm
Graph (b) is the result
under the same condition
except with the field of
twice as much as the case (a).

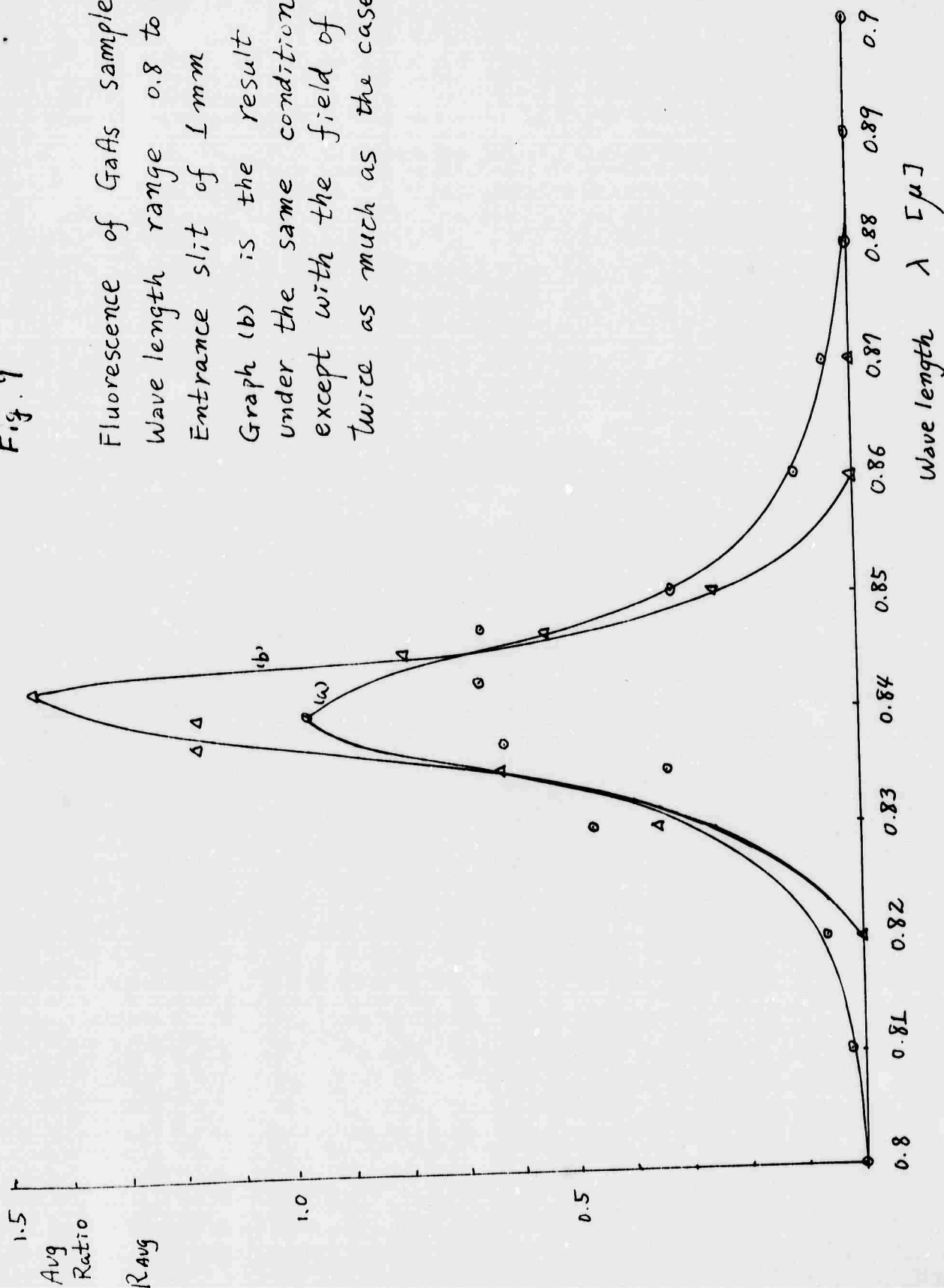

with the situation in which the primary beam is incident from an optically dense linear medium onto a less dense nonlinear medium. In this case total reflection of the primary beam may occur and the reflected harmonic light beam generated under these conditions was demonstrated recently by Bloembergen and Lee⁽⁹⁾ and later by Bloembergen, Simon and Lee⁽⁹⁾. They have shown that when the fundamental beams impinge on the nonlinear medium with equal angles of incidence from opposite sides of the normal, a nonlinear polarization component is created with zero tangential component of the wave vector. Since this polarization has the same phase at all points along the surface, it radiates harmonic in the normal inward and outward direction. The harmonic wave radiates along the normal direction will be greatly enhanced when the critical angle is approached. The increase is largely caused by the increase in linear Fresnel factor. In our present experiment we intend to extend this situation into third harmonic wave using a phase-matchable dye as the nonlinear medium following the work of Bey et al⁽¹⁰⁾. In addition we shall use picosecond pulse. In this case one expects more added features. For one thing, the two primary beams must impinge on the nonlinear medium at the same time otherwise there will be no harmonic generated along the normal direction. This provides a mean to measure the pulse width of the ultrashort pulse. The nonlinear medium has been chosen to be fuchsin red in HI. This dye solution will give maximum phase-matched third harmonic generation⁽¹⁶⁾ for a concentration of 37.5g fuchsin red in 1000 cc of HI. The data for index of refraction for this dye was also given in reference (16) for lower dye concentration and its value at phase-matching concentration is determined to be 1.2935 by the method of extrapolation. Using this value the critical angle between quartz and the dye interface is calculated to be $63^{\circ}12'$. Experiment now is in the final period of the planning stage. Actual measurement will be started very shortly.

APPENDIX

- I. Calculation of two-photon absorption coefficient from the band parameters of GaAs
- II. Calculation of ΔG from the observed change in voltage

APPENDIX I

Calculation of two photon absorption coefficient from the band parameters of GaAs:

$$A_0 = \frac{2^{17/2} \pi q^4}{\epsilon c^2 (\hbar \omega)^6} (2\hbar\omega - E_g)^{3/2} \left[\frac{|\langle \alpha p \rangle|^2}{m^2} m_{cv_1}^{\frac{1}{2}} + \frac{|\langle \alpha p \rangle|^2}{m^2} m_{cv_2}^{\frac{1}{2}} \right] \quad (I-1)$$

For GaAs crystal, $E_g = 1.41$ ev at room temp.

$$m_c = 0.07 m$$

$$m_{v1} = 0.5 m$$

$$m_{v2} = 0.01 m$$

$$\frac{|\langle \alpha p \rangle|^2}{m^2} = \frac{3 E_g}{2 m_c} \quad \text{from reference (18)}$$

$$(m_{cv_i})^{-1} = m_c^{-1} + (m_{v_i})^{-1} \quad i = 1, 2 \quad (I-2)$$

ϵ = dielectric constant = 11.8

$\hbar\omega$ = energy of laser photon = 1.17 ev

m = rest mass of electron

v = electronic charge

Substitution of these values in the equation for A_0 , we get $A_0 = 1630 \times 10^{-4}$

$$\theta = 2\hbar\omega A_0 I = 6.05 I \text{ cm}^{-1} \quad \text{if } I \text{ is in MW/cm}^2$$

$$\frac{\theta}{I} = 6.05 \text{ cm/MW.}$$

APPENDIX II

Calculation of ΔG from observed change in voltage.

To avoid contact effects, only the central portion of the crystal was illuminated with laser light. To extract the change in conductivity ΔG of the illuminated portion of the crystal from the measured voltage v , a method similar to the one discussed by Ryokin ⁽¹⁷⁾ was adopted. The simple circuit for the measurement of change in voltage due to change of photo conductivity of the sample is shown in Fig. 10. Referred to Fig. 10, we have

$$v = (i_i - i_d)R \quad \text{(II-1)}$$

$$i_i = \text{current on illumination} = \frac{V}{(R + r_0^* - \Delta r)}$$

$$i_d = \text{dark current} = \frac{V}{R + r_0^*}$$

r_0^* = the dark resistance of the whole sample

Δr = change in resistance upon illumination.

Substituting the values of i_i and i_d in (II-1) we get for Δr

$$\Delta r = \frac{v(R + r_0^*)}{VR + v(r_0^* + R)} \quad \text{(II-2)}$$

Δr is the change in resistance of the central portion only. Therefore the change in conductivity

$$\Delta G = \frac{1}{r_0 - \Delta r} - \frac{1}{r_0}$$

FIG. 10

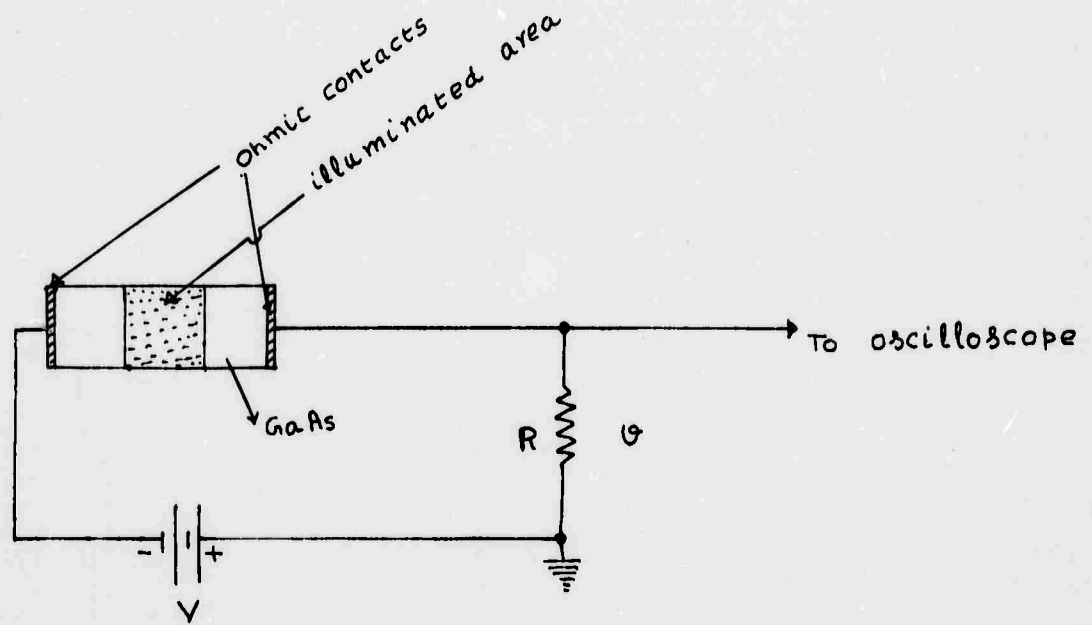

where r_0^0 is the dark resistance of the illuminated portion alone.

Equating (II-2) and (II-3), we get an expression for the conductivity as

$$\Delta G = \frac{v(r_0^* + R)^2}{r_0^0{}^2 RV + v \left[r_0^0{}^2 (r_0^* + R) - r_0^0 (r_0^* + R)^2 \right]} \quad (\text{II-4})$$

Thus it is found that ΔG is a nonlinear function of v and it can be estimated provided we know the values of V , R , $r_0^* + r_0^0$.

The equa. (II-4) can be studied thoroughly. For given V , R , $r_0^* + r_0^0$, since ΔG is nonlinear with v , v will reach a finite value when ΔG becomes infinity. This means the resistance becomes zero.

This leads to

$$\begin{aligned} r_0^0{}^2 RV &\geq v \left[-r_0^0{}^2 (r_0^* + R) + r_0^0 (r_0^* + R)^2 \right] \\ r_0^0 R &\geq \frac{v}{V} \left[(r_0^* + R)^2 - r_0^0 (r_0^* + R) \right] \\ &\geq \frac{v}{V} (r_0^* + R - r_0^0)(r_0^* + R) \\ \frac{v}{V} &\leq \frac{r_0^0 R}{(r_0^* + R - r_0^0)(r_0^* + R)} \end{aligned} \quad (\text{II-5})$$

Since the function in (II-4) is nonlinear, for larger ΔG values, v changes very little. So at higher intensities, the change in v is so small that one could not measure the change in conductivity at high intensities. By adjusting the parameters R , V , r_0^0 , one can investigate up to what intensity one can observe the changes in v . So if one can plot the v versus intensity, it appears to saturate above a particular intensity. This voltage v can be taken as the voltage change due to infinite conductivity.

For this case, the equality holds good in equation (II-5)

$$\frac{v}{V} = \frac{r_0^0 R}{(r_0^* + R - r_0^0)(r_0^* + R)}$$

A graph of v versus I is plotted and the asymptotic value of v is used to calculate r_0^0 , the dark resistance of the illuminated portion. Ryokin⁽¹⁷⁾ suggests the thin wire probe measurement of the dark resistance of the illuminated portion. Since it is inconvenient to measure using thin wire probes (particularly when a pulsed laser is used), we adopted the above method to estimate r_0^0 . Once r_0^0 is estimated, one can estimate the ΔG through equation (II-4).

REFERENCES

- (1) J. A. Armstrong, Appl. Phys. Letters 10, 16 (1967).
- (2) J. A. Giordmaine, P. M. Rentzepis, S. L. Shapiro and K. W. Wecht, Appl. Phys. Letters 11, 216 (1967).
- (3) R. C. Eckardt and C. H. Lee, Appl. Phys. Letters 15 425 (1969).
- (4) N. G. Basov, A. Z. Grasyuk, V. F. Efimkov, J. G. Zukarev, V. A. Katulin and Yu M. Popov. Proceedings of the International Conference on the Physics of Semiconductor, Physical Soc. of Japan, p. 277, (1966) Kyoto, Japan.
- (5) J. H. Yee, Appl. Phys. Letters 14, 231 (1969), 15, 431 (1969); Phys. Rev. 186, 778 (1969).
- (6) N. G. Basov et al., Soviet Physics JETP 23, 366 (1966).
- (7) S. Wang and C. C. Chang, Appl. Phys. Letters 12, 193 (1968).
- (8) A. J. DeMaria, D. A. Stetser and H. Heynau, Appl. Phys. Letters 8, 174 (1966).
- (9) N. Bloembergen and C. H. Lee, Phys. Rev. Letters, 19, 835 (1967); N. Bloembergen, H. J. Simon and C. H. Lee, Phys. Rev., 181, 1261 (1969).
- (10) P. P. Bey, J. F. Giuliani and H. Rabin, Phys. Rev. 184 849 (1969).
- (11) B. V. Zubov et al. JETP Letters 9, 130 (1969).
- (12) A. Z. Grasyuk et al., Soviet Physics, Solid State 10, 427-431 (1968).
- (13) J. M. Ralstron and R. K. Chang, Opto-Electronics 1, 182 (1969).
- (14) N. Bloembergen and P. S. Pershan, Phys. Rev. 128, 606 (1962).
- (15) N. Bloembergen, Opt. Acta 13, 311 (1966).
- (16) P. P. Bey, J. F. Giuliani and H. Rabin, J. QE. 4, 932 (1968).
- (17) Ryokin. S. M. "Photoelectric Effects in Semiconductors" Text, Consultants Bureau, New York (1974) p. 20-32.
- (18) L. V. Keldysh, Sov. Phys. JETP. 18, 253 (1964).

FIGURE CAPTIONS

- Fig. 1. Proposed experimental arrangement for measurement of picosecond pulses using two-photon conductivity effect.
- Fig. 2. (a) Band structure of GaAs.
(b) Experimental set-up for two-photon conductivity measurement.
- Fig. 3. Dependence of I_0/I_x on I_0 for GaAs sample.
- Fig. 4. Change of photoconductivity vs incident power density for low intensity region.
- Fig. 5. Change of photoconductivity vs incident power density for 0.2 MW/cm² to 4 MW/cm² region.
- Fig. 6. Theoretical curve of change of photoconductivity for our sample.
- Fig. 7. Orientation and specification of GaAs sample in the two-photon fluorescence experiment.
- Fig. 8. Experimental set-up for TPF of GaAs single crystal.
- Fig. 9. TPF spectrum of GaAs crystal.
- Fig. 10. Circuit for the measurement of ΔG

Mar 7, 66

Security Classification

DOCUMENT CONTROL DATA - R & D*(Security classification of title, body of abstract and indexing annotation must be entered when the overall report is classified)*

1. ORIGINATING ACTIVITY (Corporate author) Department of Electrical Engineering University of Maryland College Park, Maryland 20742		2a. REPORT SECURITY CLASSIFICATION Unclassified	
		2b. GROUP	
3. REPORT TITLE The Study of the Interaction of Intense Picosecond Light Pulse with Material			
4. DESCRIPTIVE NOTES (Type of report and inclusive dates) a quarterly technical report, March 19, 1970 to June 18, 1970			
5. AUTHOR(S) (First name, middle initial, last name) Chi H. Lee			
6. REPORT DATE July 18, 1970		7a. TOTAL NO. OF PAGES	7b. NO. OF REFS 17
8a. CONTRACT OR GRANT NO. DA-ARO-D-31-124-70-G50		9a. ORIGINATOR'S REPORT NUMBER(S)	
b. PROJECT NO. ARPA Order No. 675, Am. 7			
c. Program Code no. 9E20		9b. OTHER REPORT NO(S) (Any other numbers that may be assigned this report)	
10. DISTRIBUTION STATEMENT Reproduction in whole or in part is permitted for any purpose of the United States Government			
11. SUPPLEMENTARY NOTES		12. SPONSORING MILITARY ACTIVITY ARPA and U. S. Army Research Office	
13. ABSTRACT This report covers work under contract DA-ARO-D-31-124-70-G50 for the period March 19 to June 18, 1970. Topics discussed include two-photon conductivity effect and two-photon fluorescence effect from GaAs crystal with dye Q-switched Nd:glass laser. Third harmonic generation at total reflection of the primary beam of picosecond pulses is also discussed			

Mar 7, 66

Security Classification

14 KEY WORDS	LINK A		LINK B		LINK C	
	ROLE	WT	ROLE	WT	ROLE	WT
Laser Picosecond light pulses Two-photon absorption Fluorescence Photoconductivity Semiconductor laser Mode-locked laser Total reflection Harmonic generation Ultrashort pulse measurement						