

R. Stream
T-5

U. S. Naval Ordnance Laboratory, White Oak, Silver Spring, Md.

NAVAL ORDNANCE LABORATORY MEMORANDUM 9959

7 February 1949

From: J. H. Ayres
To: NOL Files
Subj: Explosive Electrostatic Sensitivity Tester, the Design, Assembly, and Operation of. (NOL-12-Re2a-184-2).

Abstract: The need has arisen in the Naval Ordnance Laboratory for an apparatus to measure the susceptibility of explosives and pyrotechnic materials to initiation by a static electrical spark discharge. By charging a known condenser to a known voltage, a calculable quantity of energy can be dissipated in a spark through an explosive sample. After some preliminary work at the Naval Ordnance Laboratory and after the inspection of the apparatus at the Bureau of Mines, it was decided to build an apparatus of the design given below. Although the basic circuit is quite simple, much care was taken to eliminate loss of charge that might arise from corona or surface leakage.

Foreword: The data and conclusions presented herein are preliminary information for the use of the Engineering Department. They may not represent the final judgment of the Laboratory.

Refs: (a) Bufiles Report, "Sensitivity of Explosive to Initiation by Electrostatic Discharges" (R.I. 3852) dated January 1946.
(b) BuOrd ltr. NP51(Re2a-184-2) WES/11b dated 25 October 1948. (NOL File NP51/S78-1 Pr)1740).

Encls: (A) Plates 1 through 8.

I. NEED FOR SPARK SENSITIVITY DATA

1. Safety in Handling: Explosive compositions which are notorious for their susceptibility to initiation by electrostatic discharge are being used in many ordnance designs. From the standpoint of safety of handling of the explosive loads, it is extremely desirable to desensitize the explosive. Obviously, some quantitative method of measuring the sensitivity is required. A criterion of acceptability could then be established.

2. Mechanism of Initiation: In studying the mechanisms of the initiation and propagation of shock waves in explosives, one avenue of approach is to attempt to correlate the energies required for various methods of initiation, such as by electric spark, by hot wire, by mechanical impact, by open flame, by explosive shock wave, etc. In order to obtain spark

NAVAL ORDNANCE LABORATORY
TECHNICAL LIBRARY 1-355
WHITE OAK, SILVER SPRING,
MARYLAND 20910

NOLM No. 9959

UNCLASSIFIED

This document is on loan,
return to:

DATE DUE: 27 November 1970

16

AD 713 397

Reproduced by the
CLEARING HOUSE
for Federal Scientific & Technical
Information Springfield Va. 22151

NOTICE TO USERS

Portions of this document have been judged by the Clearinghouse to be of poor reproduction quality and not fully legible. However, in an effort to make as much information as possible available to the public, the Clearinghouse sells this document with the understanding that if the user is not satisfied, the document may be returned for refund.

If you return this document, please include this notice together with the IBM order card (label) to:

Clearinghouse
Attn: 152.12
Springfield, Va. 22151

DISCLAIMER NOTICE

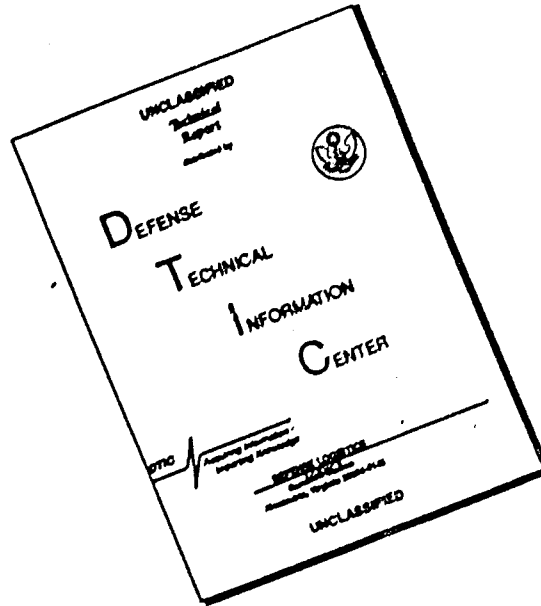

THIS DOCUMENT IS BEST QUALITY AVAILABLE. THE COPY FURNISHED TO DTIC CONTAINED A SIGNIFICANT NUMBER OF PAGES WHICH DO NOT REPRODUCE LEGIBLY.

initiation data of any value in such a correlation, quantitative results are required. Here, however, the problem is probably much more difficult because absolute energy values would be desired rather than relative values referred to an arbitrary scale. Although the amount of electrical energy available in a particular test might be determined readily, it might be quite difficult to estimate the ratio* of energy dissipated in the explosive to the total energy discharged in the system.

3. Immediate Objective: A directive from the Bureau of Ordnance (reference (a)) specifically requests that sensitivity data be obtained for use in the project outlined therein. Because of the urgency of the request, the limited design which is described in Section V was adopted and the apparatus built.

II. METHOD OF DETERMINATION

1. Calculation of Energy Absorption: If a condenser (D) (See Plate I, Fig. 1) were to be charged to a known voltage and then discharged in an arc between two electrodes (A & C) through an explosive sample (B), the energy dissipated in the sample would be equal to the energy stored in the condenser multiplied by the absorption coefficient.

$$E = 50V^2(\alpha) \text{ where: } E \text{ is energy in ergs}$$

C is capacity in micromicrofarads
 V is potential in kilovolts
 α is absorption coefficient.

If, in an arc discharge of this nature, it is assumed that the value of would not be too different from the value which would apply to a spark jumping between an explosive sample and a charged and electrically insulated human being, then an arbitrary scale of comparison can be readily set up, which would be useful in estimating loading and handling hazards. In selecting the dividing line between "safe" and "unsafe", one should remember that measurements have shown that it is possible, under appropriate conditions, for a human being to show an effective capacity to ground of 400 mafd, and to accumulate a charge of 15KV,—an energy of approximately 500,000 ergs.

2. Basic Circuit: The essentials of a suitable testing device would be a capacitor of known value, a removable source of charging voltage, a method of determining the potential to which the capacitor is charged, and an electrode system to guide the condenser discharge arc through the explosive sample.

* This ratio will be termed "absorption coefficient" throughout this paper, and will be designated by alpha (α). It is appropriate at this point to emphasize the fact that α is an arbitrary "bugger" factor to account for the large difference between energy required to initiate explosive by spark discharge and the energy required for some other process, such as by a hot wire. Sources of variation of α probably can be found in some of the parameters mentioned in paragraph 2 of Section VI.

III. BACKGROUND

1. Preliminary Work at NOL: The results given in the Bureau of Mines Report (reference (a)) were used as an indication of the probable range of operation that would be needed for the intended study. For a preliminary apparatus, a standard drop tester was modified to permit placing an explosive sample on an insulated and charged electrode. (See Plate 1, Fig. 2 and Plate 2). A grounded pointed electrode was moved down into arcing distance from the explosive by the drop height adjustment mechanism. Plasticon "Glasslike" condensers were charged up through an appropriate resistor by a DuPont 10 KV R.F. Supply. The explosive holder was insulated by a piece of polystyrene. An interlock control system was installed to protect against premature firing of the sample and to lessen the chance of electrocuting the operator.

2. Limitations of Preliminary NOL Apparatus: Results with some relatively insensitive samples agreed fairly well with those of the Bureau of Mines. However, when the lower energy ranges were tried, it was impossible to maintain an isolated charge because of corona and leakage losses. When the condenser was connected to the power supply through a sufficiently low resistance to compensate for these losses, the RC constant was so short that repetitive discharges occurred.

3. Limitations of Bureau of Mines Apparatus: At this point, it was decided that a trip to Druceton, Pa. to inspect the Bureau of Mines apparatus was in order. This trip verified the difficulty inherent in attempting to maintain a high voltage charge on a small capacitor installed in this type of apparatus. An attempt to cut down losses had been made by dehumidifying the apparatus and the room in which it was installed. Even so, there seemed to be definite reasons to feel that it would not be possible to expect this apparatus to function satisfactorily below about 100,000 ergs.

4. Immediate Requirements: In order to obtain data for explosives whose energy ranges were expected to fall between 2,000 and 60,000 ergs, it was decided that no available apparatus was suitable. Since the need for these data was urgent it was decided to expedite the construction of an apparatus of limited range. Utmost care was to be exercised, nevertheless, to minimize leakage and corona losses. Design to minimize radiation loss was considered secondary to simplicity and ease of manufacture.

IV. DESIGN CONSIDERATIONS

1. Specifications of an Ideal Design: It is felt that the following requirements should be met in the design of a versatile test and research instrument.

- (a) Charging voltage to be variable from 4 KV to 20 KV.
- (b) Capacity adjustable from 25 mfd to 0.1 mfd in steps no greater than 50 mfd. This would permit testing of materials ranging from the extremely sensitive to such comparatively

- insensitive substances as Mg powder, TNT, etc.
- (c) The probe should be so arranged that it could be brought rapidly and repeatedly to any desired distance from the surface of the explosive sample.
 - (d) The polarity of the probe with respect to the explosive should be reversible.
 - (e) All components and electrodes should be mounted on insulators with long leakage paths between the two sides of the system and long leakage paths to ground. The insulators should have the highest possible volume and surface resistivities.
 - (f) All components should have high voltage ratings. Capacitors and critical relays should have negligible cold emission characteristics at 20 KV. The leakage resistance of each capacitor and its associated switches and connectors should be so high that its RC time would exceed 10 minutes.
 - (g) All capacitor switching must be done by relays or other suitable remote control device. Connecting or disconnecting capacitors by hand (as is done in the Bureau of Mines apparatus) is not only dangerous even with the best of interlock systems, but is not a precision technique. It would be very difficult to carry out manual changing of capacitors without seriously impairing leakage resistances because of the deposition of conductive films of perspiration, finger marks, etc.
 - (h) The electrodes should be separated from the energy source so that corrosive firing gases can be kept away from leakage-sensitive surfaces.
 - (i) The energy source (power supply, capacitors, interlock switch, isolation and selector relays) should be completely enclosed in a dust-free and dehumidified chamber.
 - (j) All connections should be made with conductors at least 1/4" in diameter. All terminating lines, bends, "T" connections and sharp corners, edges or points should be corona-protected by the use of 3/4" or larger spherical surfaces, shields, or other devices to reduce local high stress potential gradients. All conductors must be polished and free from scratches and dust to prevent point brush discharges.
 - (k) The charged capacitor and electrode system must hold its potential after being completely isolated from the power source. This charge should be maintained with less than 1% loss of voltage for the time required for the test.

2. Specifications of Compromise Design: It was found that by using immediately obtainable material, an apparatus could be constructed which would meet nearly all the requirements listed above. The capacitor range would not be as large in capacity or as high in voltage rating. Ten G. E. Vacuum Capacitors rated at 50 mfd. and 5 KV were used. Selector relays and isolating relays were the Eimac Vacuum Relays VS-1 type. Under certain

conditions some of the relays were observed to spark during operation. This spark did not appear to be a gassy or glow discharge. In addition, some of the Vacuum capacitors appeared to be polarity sensitive. Even though these capacitors could be charged to the rated 5,000 volts without appreciable leakage, when the charge polarity was reversed, leakage and occasional glow discharge occurred even at voltages as low as 2,500 volts.

V. DESCRIPTION OF INSTALLATION

1. General Arrangement: (See Plates 3 and 4). The housing is a lucite box five feet long, two feet high, and two feet deep, divided into two compartments--a cubical firing chamber and a rectangular chamber to house the power assembly. The firing chamber is connected to a piping and damper arrangement to circulate dry air and to exhaust firing gases. The power chamber is equipped with an access door at the end to permit introduction of dessicant to lower the humidity of the chamber as required. Lucite was selected for the material of construction for the main housing for the following reasons:

- (a) It was readily available.
- (b) It was easily machined.
- (c) It is structurally insensitive to moisture changes.
- (d) It is a good insulator, thus aiding in the reduction of leakage.
- (e) It is transparent, thus permitting close inspection of operation at all times.

2. The Power Chamber: Installed in this chamber is the power equipment which consists of an input from the high voltage power supply, polarity reversing relay, isolating relays to permit disconnecting the capacitors from the power supply and a bank of capacitors and relay assemblies to permit switching in varying total capacities. An electrostatic volt meter is permanently connected to the bus-bars which lead into the firing chamber.

3. The Firing Chamber: (See Plate 5). In this chamber are mounted two electrodes: the lower rigidly mounted electrode being the explosive support, and the upper electrode, a sliding point which can be moved down into arcing distance. Both electrodes are mounted on machined polystyrene supports. These supports were designed to give long leakage paths and to provide recessed surfaces which would tend to be out of the path of flying fragments and explosive gaseous products. The upper electrode is essentially a sliding spring-supported brass rod which ties through a collar connected to the upper bus-bar. The sliding electrode is insulated from the operator by means of a polystyrene handle. The bottom limit of travel of the upper electrode is controlled by a threaded adjusting unit. To prevent placing the explosive sample on the lower electrode while it is charged, a sliding door has been located on the operator's side of the chamber. Opening this door operates an interlock mechanism which shorts the upper and lower bus-bars through a piece of copper strip. A large access door, held in place by machine screws, was installed in the end of the apparatus to facilitate working on the door interlock system and the electrodes. If necessary the entire

panel on the operator's side can be removed complete with the interlock mechanism.

4. The Piping System: (See Plates 6 and 4). A fairly elaborate system of pipes and dampers was installed so that dry air from a self-regenerating desiccant dehumidifier could be circulated through the firing chamber and through the room in which the test apparatus was installed. By proper manipulation of the dampers it is possible to direct any desired portion of the air flow from the dehumidifier into the firing chamber. Further, it is possible to control the flow going through a bypass which houses a humidity indicator. During actual firing it is desirable to shut off the air stream through the firing chamber, and immediately after firing the decomposition products must be completely ejected into a suitable disposal system. Since these gases are corrosive and toxic, the dampers were arranged to prevent their flow through either the dehumidifier or the humidity indicators. A conveniently accessible control panel was made possible by using Bowden cables to operate the various dampers.

5. The Capacitor Relay Assembly: (See Plates 7 and 3). Ten C. E. Capacitors were mounted in five groups, one group of four, two groups of two, and two single condensers on polystyrene plates which were in turn supported by polystyrene legs fastened to the base of the power chamber. Five vacuum relays were mounted on a polystyrene plate which was suspended by polystyrene supports from the top face of the power chamber. When energized electrically, the relays are arranged to disconnect the five condenser groups from a common header. The lower ends of the vacuum condensers are all connected together by a system of brass rods and connectors. From this common circuit a bus-bar is carried through the dividing wall on a double coneshaped polystyrene insulator into the firing chamber and connected to the lower electrode. The header into which the vacuum relays are connected is fed into a bus-bar which connects to the upper electrode assembly. A three scale electrostatic voltmeter, made by the Sensitive Research Instrument Co., is permanently connected between the upper header and the lower common circuit. The voltmeter thus measures the potential developed across the capacitors and the electrode system at all times. Special precautions were taken to corona-shield all connections to the components of this assembly. Such devices as sliding sleeves, hollow tubes and round edged plates were used. Two more vacuum relays were arranged to isolate the capacitor-relay assembly from the power charging source. The isolation relays, one for the upper header, the other for the lower common circuit were both mounted on polystyrene blocks.

6. Control Box: (See Plate 6). A bakelite box was constructed to house the power and control switches. To operate the polarity reversing relays 110 AC was required. All vacuum relays are operated from 110 AC through dropping resistors. Enough switches and connections were incorporated to permit the operation of higher capacity ranges to be installed at a later date. The wiring diagram for the whole apparatus is shown on Plate 8.

VI. OPERATION OF TESTER.

1. Procedure: Explosive samples weighing 16 mg. are loaded into the

plastic holder. (See Plate 1, Fig. 3). With the firing chamber door open so that the electrodes are shorted out, the loaded explosive holder is placed on the lower electrode. The probe polarity is determined, and the desired capacitor* step size selected. The door is then closed and the capacitors are brought up to voltage by adjusting the voltage control knob on the face of the DuMont power supply. When the desired voltage (as indicated by the electrostatic voltmeter) has been reached, the isolation relays are operated by the spring return switch on the control box marked "ISOLATE". If there is leakage in the firing system, it will show up at this point by a gradual decrease in the reading on the voltmeter. Firing is accomplished by manually depressing the probe to the limit of travel, which travel has been previously adjusted by the stop nut. With primary explosives there is usually no doubt to the observer when a sample has been successfully initiated. After firing, the gaseous products are removed and dry air is again circulated through the chamber. Normally the air flow through the chamber is shut off at the actual moment of sparking.

2. Analysis of Results: As might be expected from the nature of electrical gas discharge and from the behaviour of explosives under initiating conditions, there is apparently a spread or range of sensitivity readings from any group of test samples representing a particular explosive. An analysis of results by appropriate statistical methods would therefore be required. These methods would give a correlation between the explosive compound and mean energy, minimum energy value beyond which the explosive will probably not be initiated, and a maximum energy above which the explosive will probably always be initiated. Care must be taken to account for possible sources of variation in results, such as probe shape and polarity, degree of confinement particle size and loading pressure of the explosive, the ratio of voltage to capacity size for a particular energy level, humidity of sample and of test apparatus, spark length, rate of approach of probe, type of illumination of gap area (photo ionization to trip spark discharge), etc. Experimental results obtained by this apparatus and the statistical treatment of these results will be given in another report which should furnish information on the degree of importance of some of the above mentioned sources of variation.

3. Future Considerations: Present performance of the sensitivity tester seems to indicate that the apparatus as it is now arranged will probably meet the immediate requirements mentioned in Section I, paragraph 3. It is barely possible that the range of capacitors will have to be raised to a total of 5000 muf. Enough space has been left in the power chamber to permit expansion of the capacity range to this value with little rebuilding. At a later date it is recommended that the entire present capacitor relay system be replaced with non-polarity sensitive 20 KV Plasticon capacitors and suitable relays.

* The value of the capacitor is obtained by adding the engraved numerical values associated with those switches thrown to the "IN" position. It must be remembered that at the present time only the first five switches (the left end of the top row of switches of the control box) are operative. The values of the first six switches are given in micro-micro farads. The remaining switches (decimal values) are given in micro-farads.

VII. ACKNOWLEDGMENTS

1. In conclusion, the author desired to express his gratitude for the assistance that was received from many sources and which made the construction of this apparatus possible in a relatively short time. Invaluable aid was received from:

- (1) Supply, by procuring on short notice polystyrene, relays, capacitors, and the voltmeter.
- (2) HE, Coordination, by placing at our disposal the services of the shop with a minimum of red tape
- (3) Public Works, by the installation of the piping and damper system and electrical conveniences.
- (4) Technical Shops, by the skill and ingenuity exercised in performing the actual construction.
- (5) The numerous people who offered suggestions, ideas and comments.

J. N. Ayres

JNA:rd

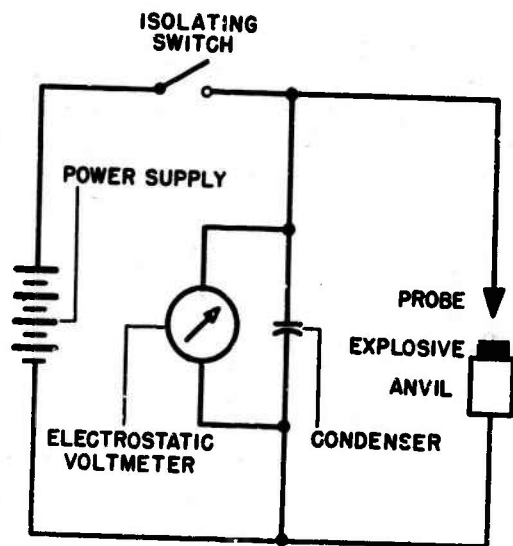

FIG. 1
FUNDAMENTAL CIRCUIT

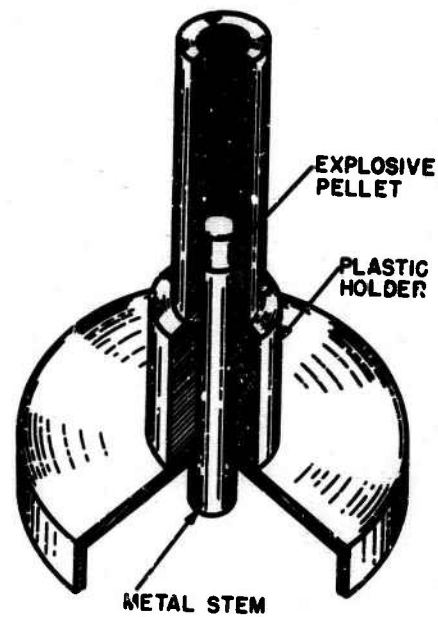

FIG. 2
EXPLOSIVE SAMPLE HOLDER

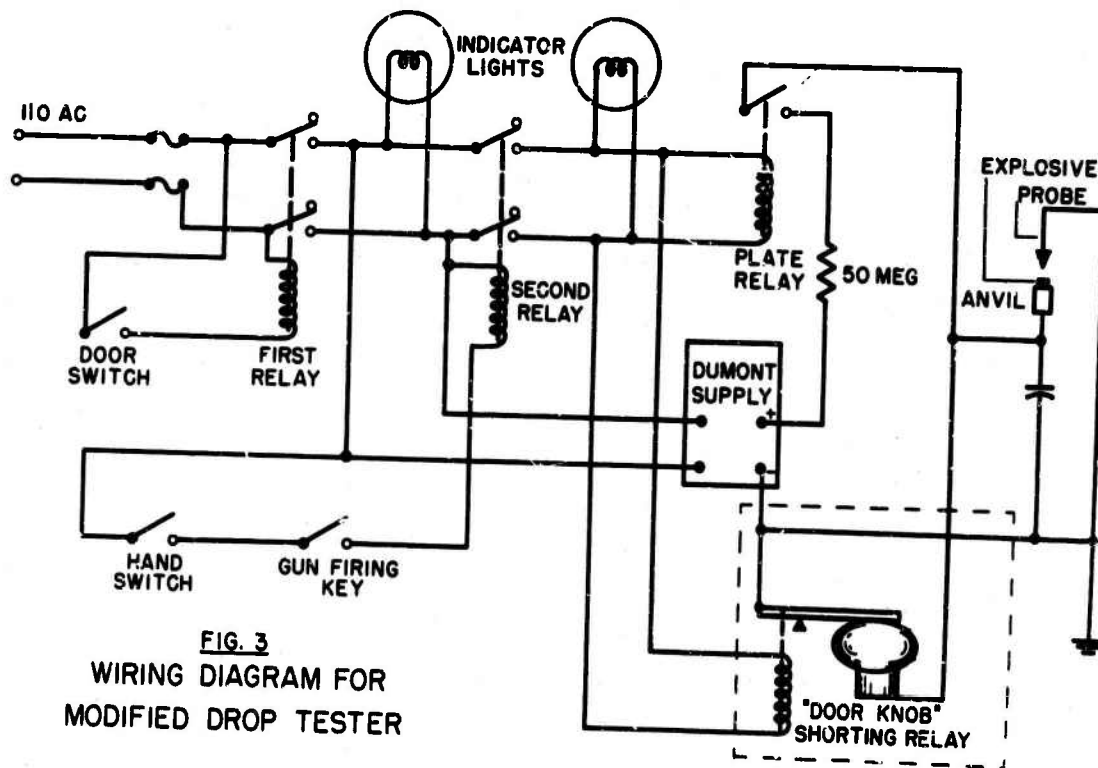
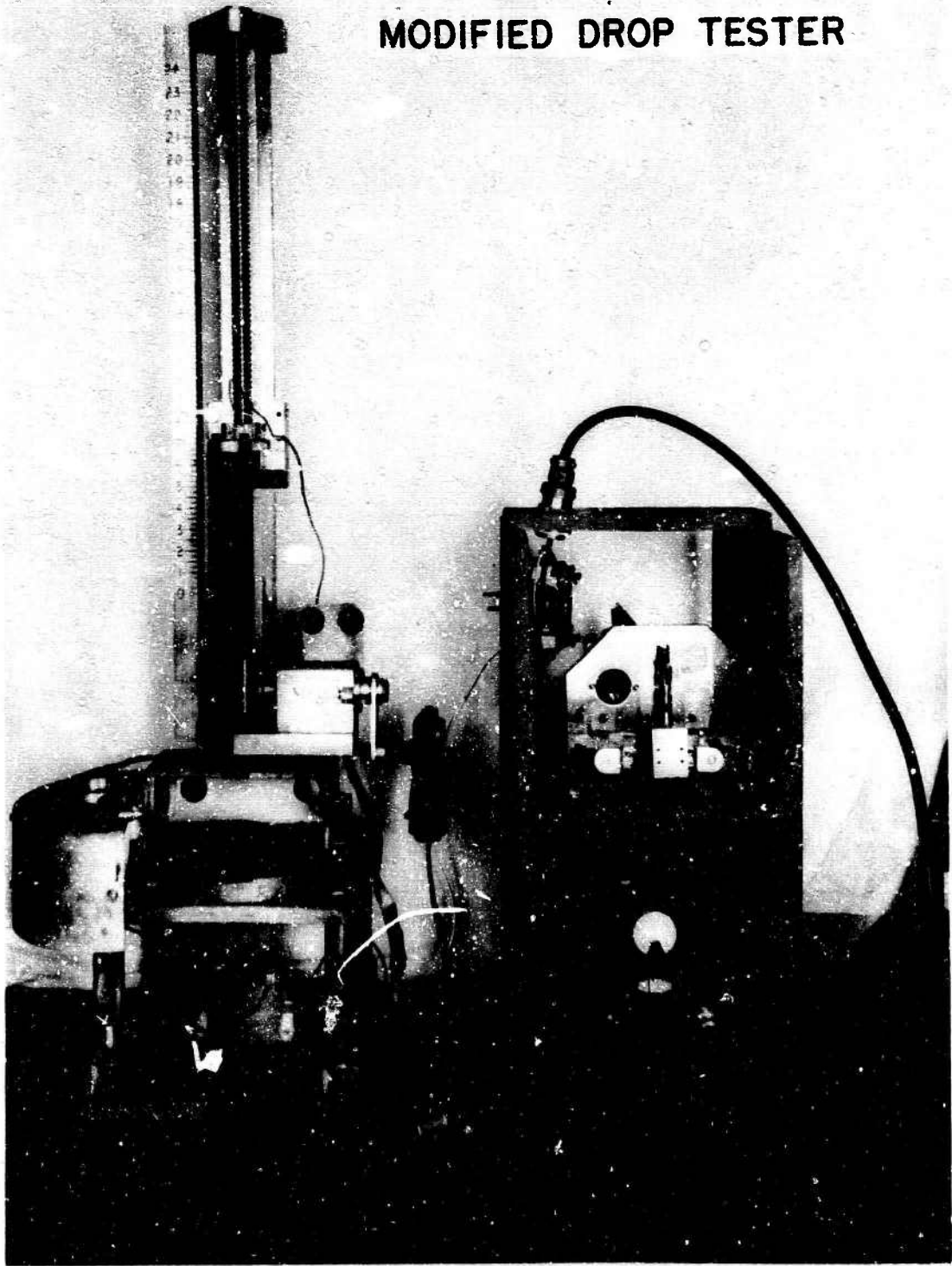
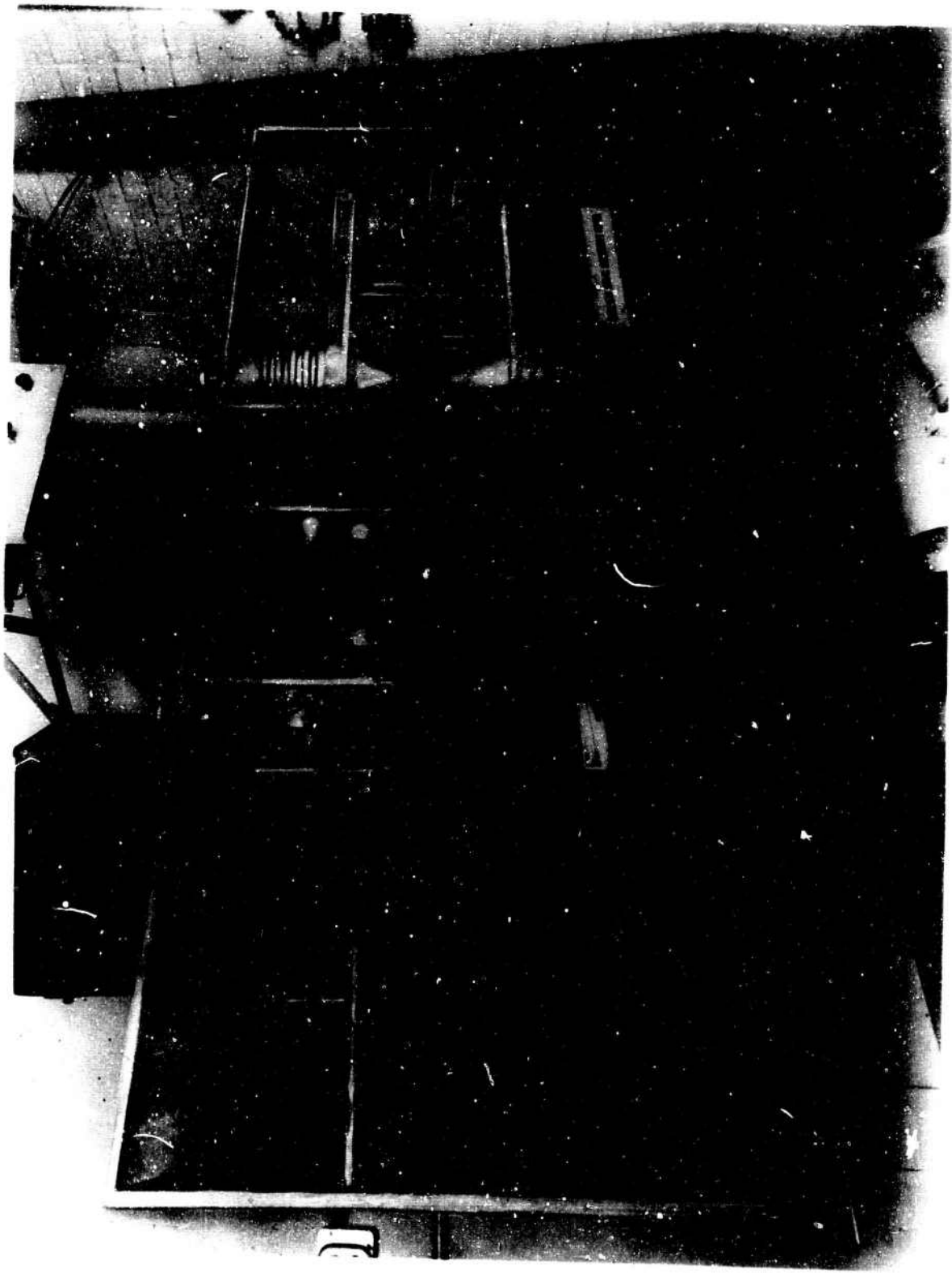

FIG. 3
WIRING DIAGRAM FOR
MODIFIED DROP TESTER

MODIFIED DROP TESTER







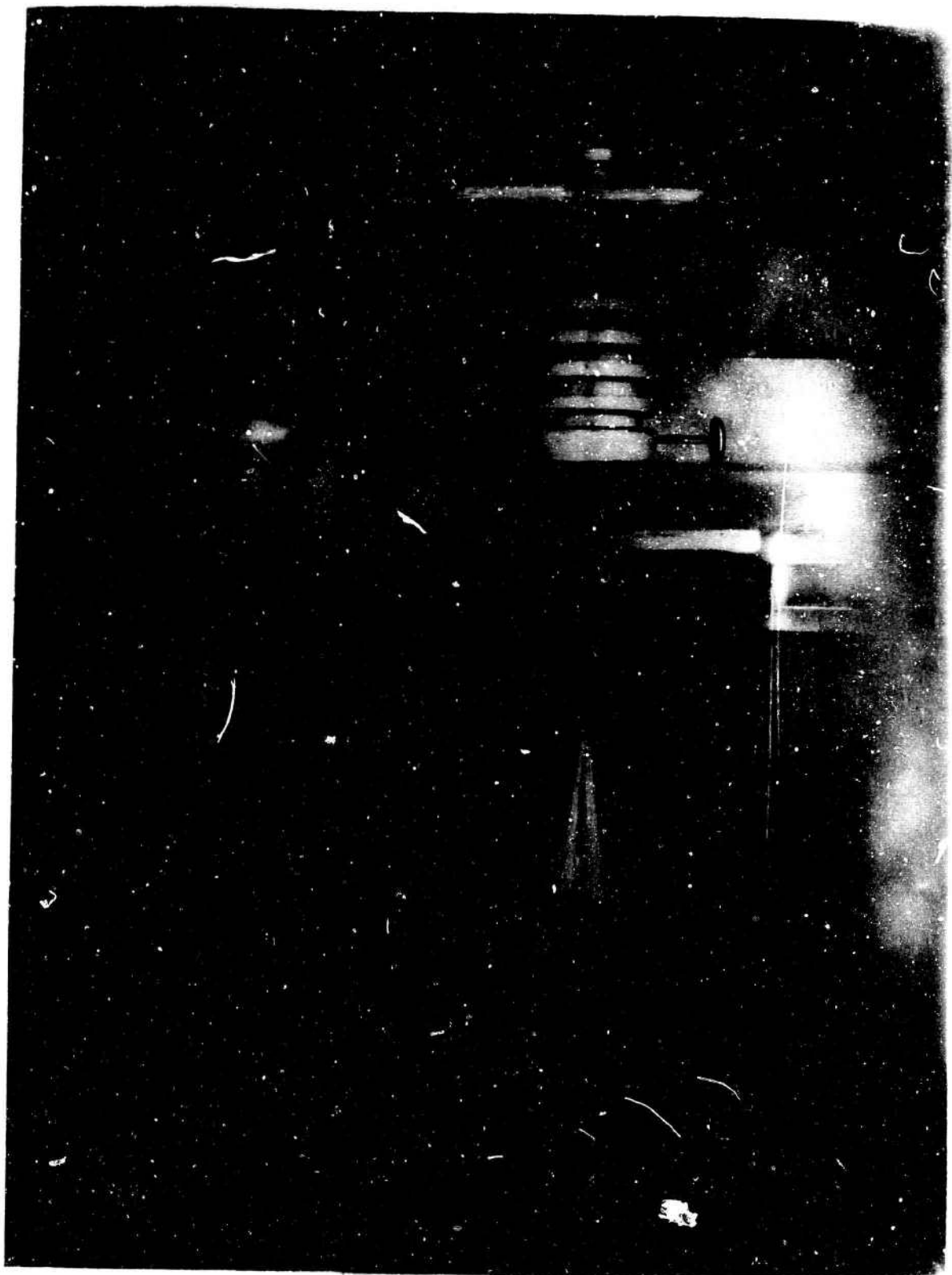

FIRING CHAMBER

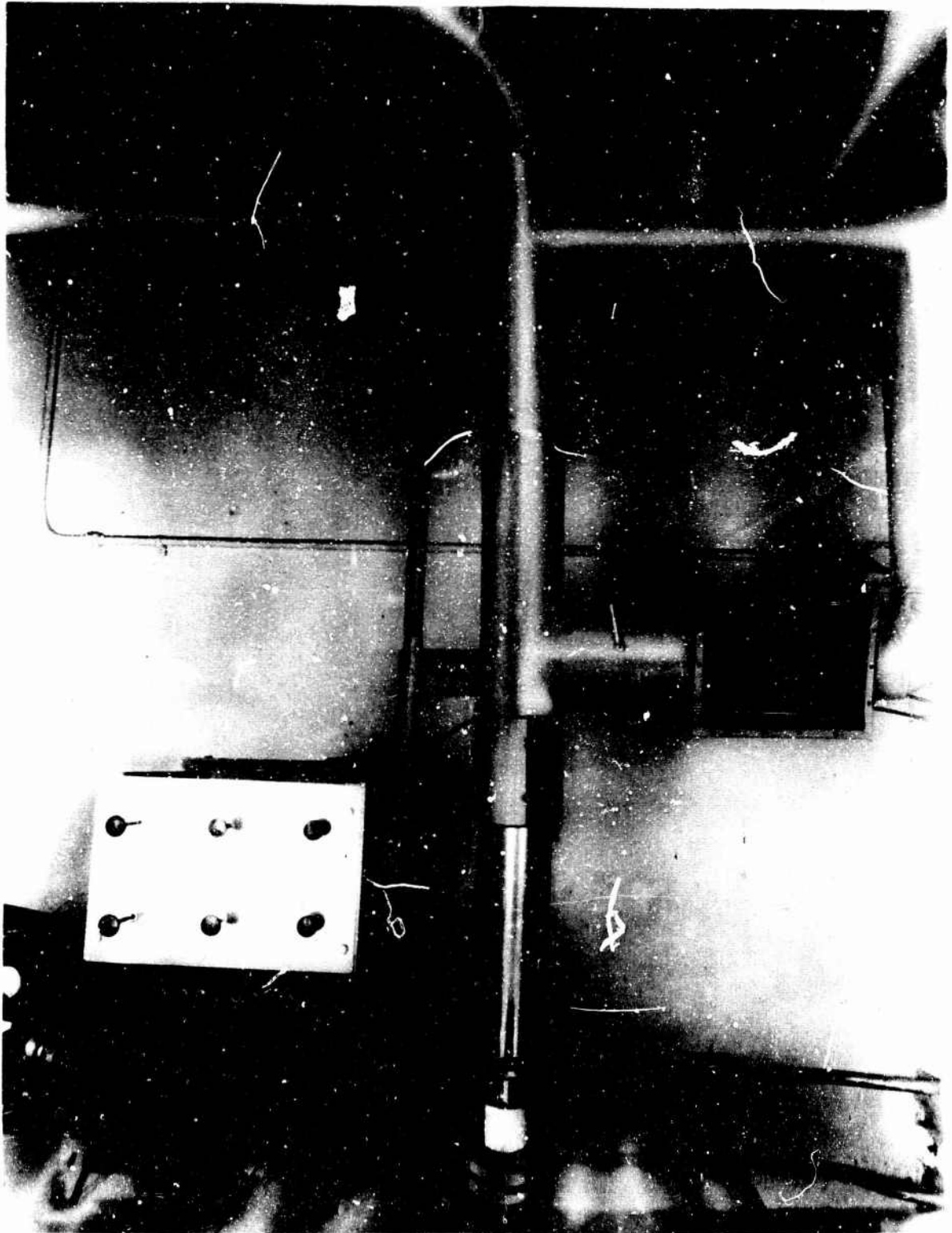

UPPER PIPING SYSTEM

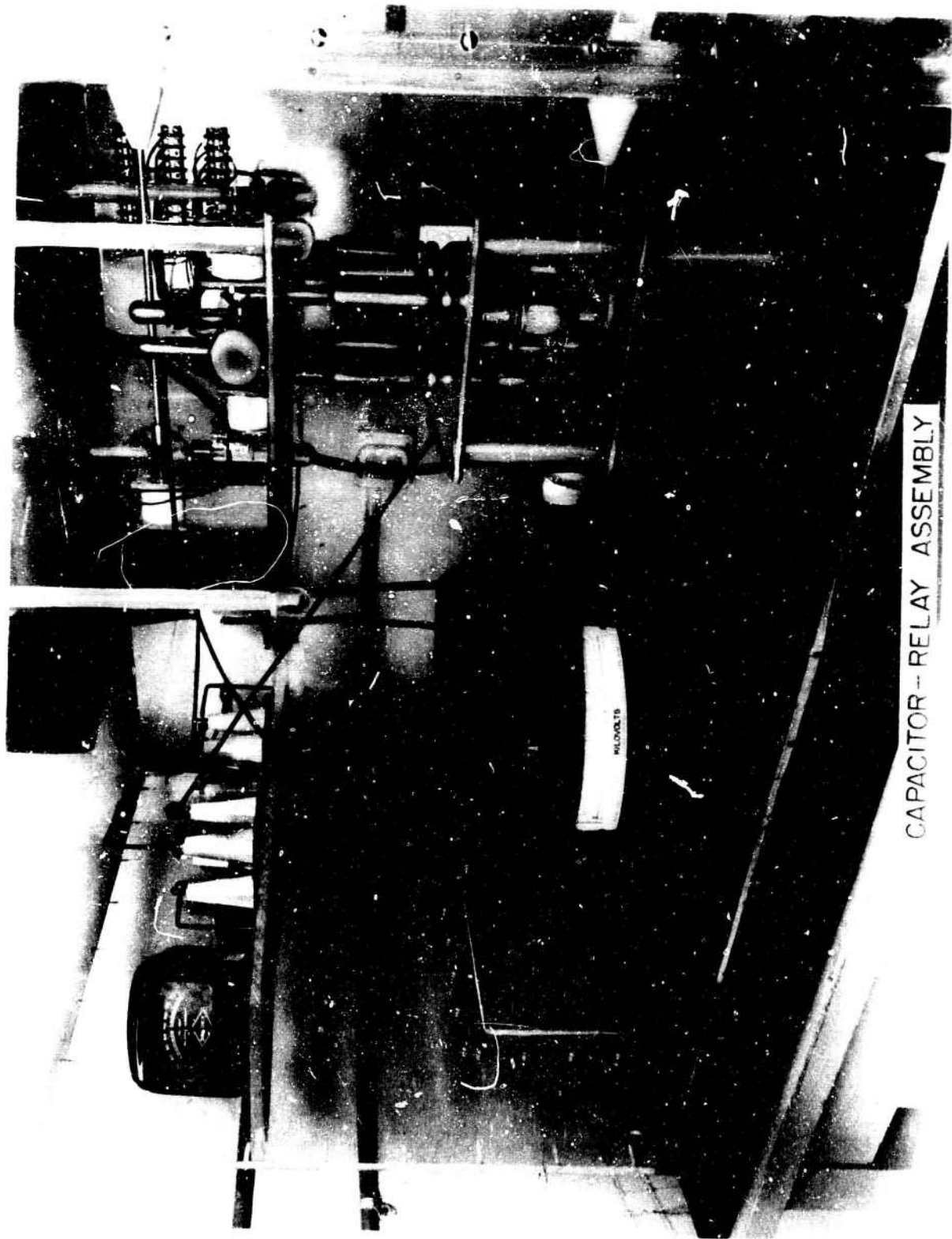

CAPACITOR -- RELAY ASSEMBLY

WARNING
 THIS DOCUMENT AND THE SPECIAL ORDER FEATURES ON
 INFORMATION DISPLAYED ARE U. S. GOVERNMENT PROPERTY. THE
 DISSEMINATION OF THIS DOCUMENT OR THE INFORMATION IT CONTAINS IN A FORM
 OTHER THAN THAT IN WHICH IT WAS ISSUED IS PROHIBITED BY FEDERAL STATUTE OR BY EXECUTIVE ORDER.

TO DUMONT HIGH
 VOLTAGE SUPPLY

CONTROL BOX

POWER CHAMBER

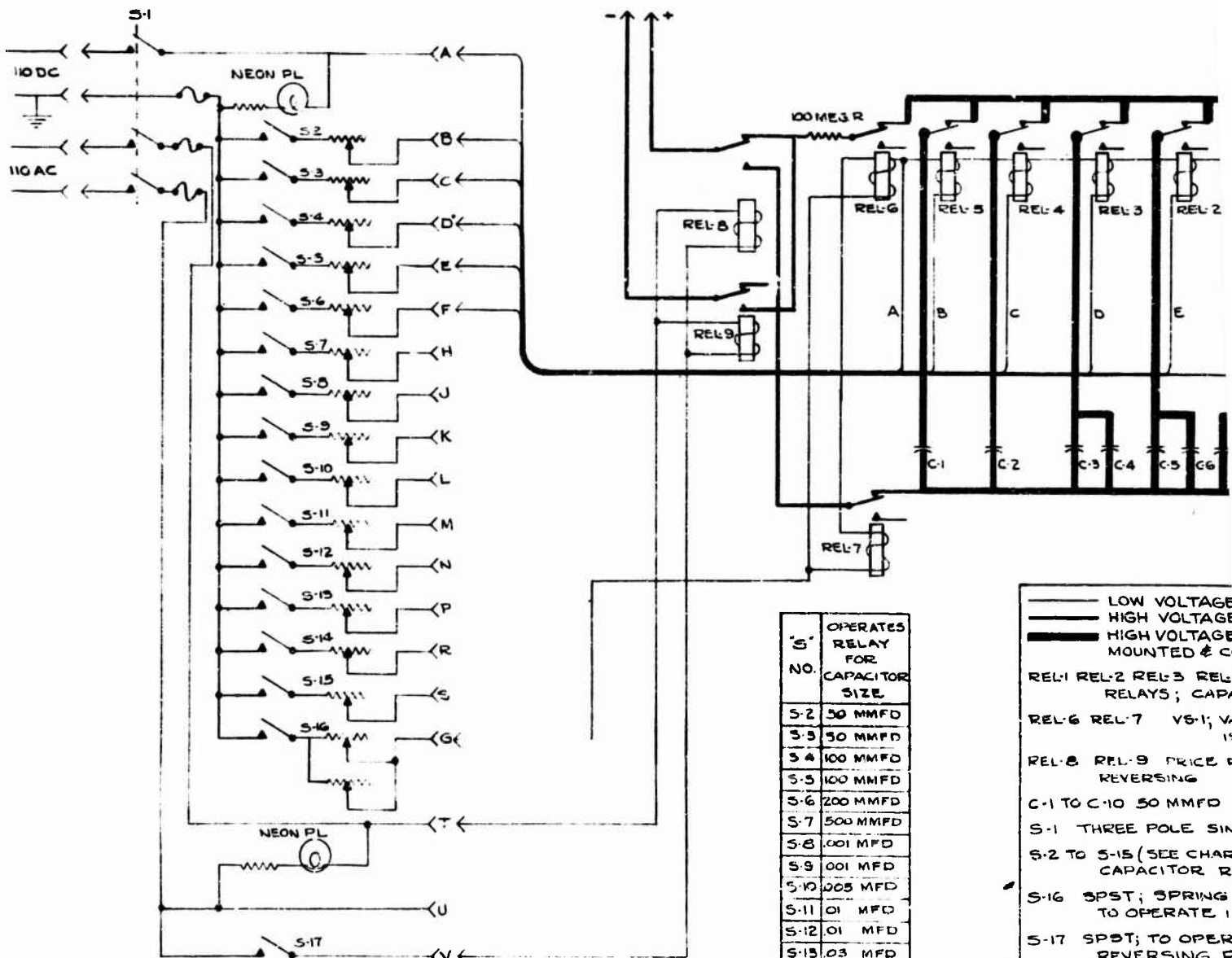

'S' NO.	OPERATES RELAY FOR CAPACITOR SIZE
S-2	50 MMFD
S-3	50 MMFD
S-4	100 MMFD
S-5	100 MMFD
S-6	200 MMFD
S-7	500 MMFD
S-8	1001 MFD
S-9	1001 MFD
S-10	1005 MFD
S-11	01 MFD
S-12	01 MFD
S-13	03 MFD
S-14	03 MFD
S-15	1 MFD

— LOW VOLTAGE
 — HIGH VOLTAGE
 — HIGH VOLTAGE MOUNTED & C
 REL-1 REL-2 REL-3 REL-4
 RELAYS; CAPA
 REL-6 REL-7 VS-1; VA
 15
 REL-8 REL-9 PRICE R
 REVERSING
 C-1 TO C-10 50 MMFD
 S-1 THREE POLE SING
 S-2 TO S-15 (SEE CHAR
 CAPACITOR RE
 S-16 SPST; SPRING I
 TO OPERATE 15
 S-17 SPST; TO OPERA
 REVERSING RE

REVISIONS			DO NOT SCALE DRAWING	APPROVED	DATE	WIRING DIAGRAM EXPLOSIVE ELECT SENSITIVITY TEST
LET.	NUMBER	DATE				
			UNLESS OTHERWISE SPECIFIED DIMENSIONS ARE IN INCHES TOLERANCES ON MACHINING DIMENSIONS: DECIMAL ± FRACTIONAL ± ANGULAR ±	CHECKED		MATERIAL
				DRAWN	1/14-49	

A

TO DU MONT HIGH VOLTAGE SUPPLY

POWER CHAMBER

FIRING CHAMBER

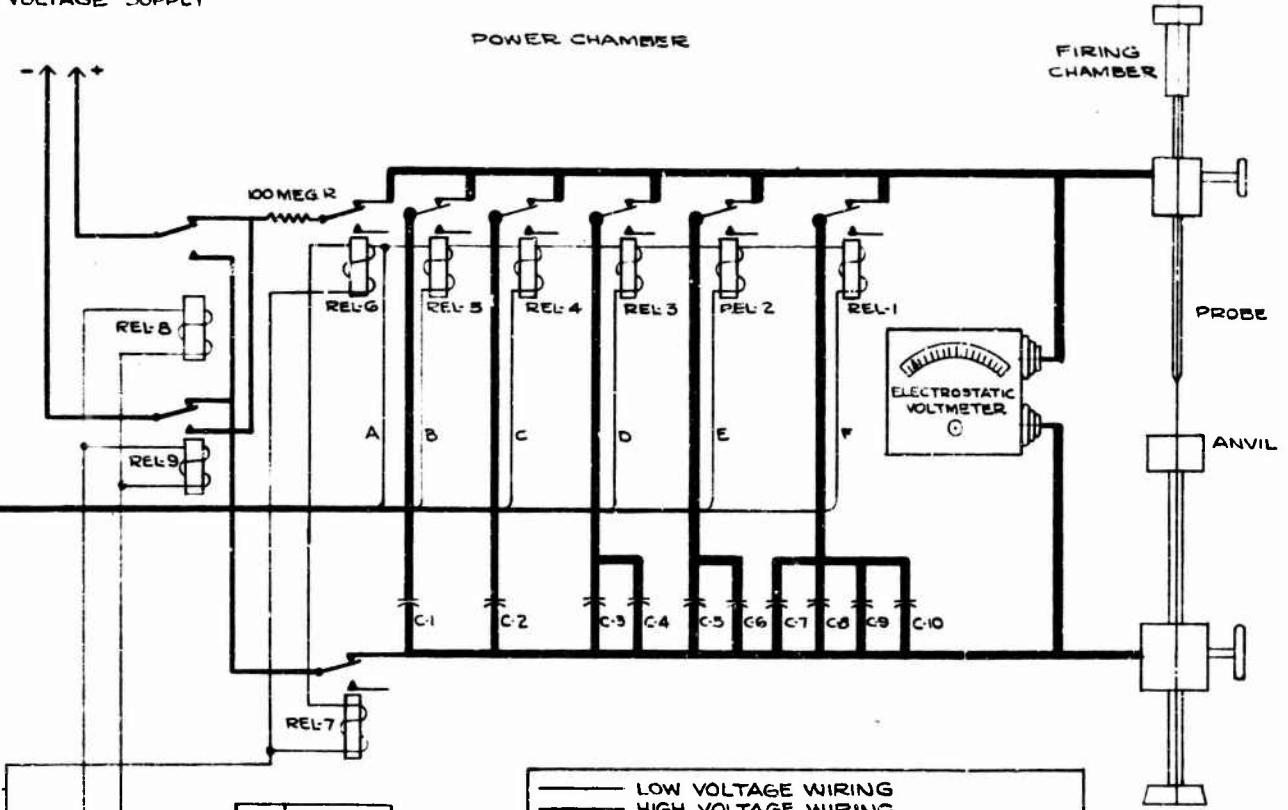

'S' NO.	OPERATES RELAY FOR CAPACITOR SIZE
S-2	50 MMFD
S-3	50 MMFD
S-4	100 MMFD
S-5	100 MMFD
S-6	200 MMFD
S-7	500 MMFD
S-8	.001 MFD
S-9	.001 MFD
S-10	.005 MFD
S-11	.01 MFD
S-12	.01 MFD
S-13	.03 MFD
S-14	.03 MFD
S-15	.1 MFD

——— LOW VOLTAGE WIRING
 ——— HIGH VOLTAGE WIRING
 ——— HIGH VOLTAGE WIRING, POLYSTYRENE MOUNTED & CORONA PROTECTED.
 REL-1 REL-2 REL-3 REL-4 REL-5 - VS-1 VACUUM RELAYS; CAPACITOR SELECTORS
 REL-6 REL-7 VS-1; VACUUM RELAYS ISOLATION RELAYS
 REL-8 REL-9 PRICE RELAYS; POLARITY REVERSING
 C-1 TO C-10 50 MMFD VACUUM CAPACITORS
 S-1 THREE POLE SINGLE THROW; POWER
 S-2 TO S-15 (SEE CHART) SPST; TO OPERATE CAPACITOR RELAYS
 S-16 SPST; SPRING RETURN NORM. OPEN TO OPERATE ISOLATION RELAYS
 S-17 SPST; TO OPERATE POLARITY REVERSING RELAYS

REVISIONS		
LET.	NUMBER	DATE

DO NOT SCALE DRAWING
 UNLESS OTHERWISE SPECIFIED
 REMOVE BURRS AND SHARP EDGES.
 DIMENSIONS ARE IN INCHES.
 TOP BRANCHES ON MACHINING DIMENSION.
 DECIMAL ±
 FRACTIONAL ±
 ANGULAR ±

APPROVED	DATE
CHECKED	
DRAWN	1/4-49

WIRING DIAGRAM OF
 EXPLOSIVE ELECTROSTATIC
 SENSITIVITY TESTER
 MATERIAL
 CLASS UNIT WT. JOB ORDER

BUREAU OF ORDNANCE, NAVY DEPARTMENT
 U. S. NAVAL ORDNANCE LABORATORY
 WHITE OAK
 SILVER SPRING 18, MARYLAND 194
 BY DIRECTION OF THE CHIEF OF BUREAU
 SCALE BUORD DRAWING NO.
 — NOL SK C-192152

NOLM 9959

B