

U.S. ARMY FOREIGN SCIENCE AND TECHNOLOGY CENTER

AD 714915



PRACTICAL AERODYNAMICS OF THE MI-6 HELICOPTER

by

M. S. Yatsunovich

COUNTRY: USSR

This document is a rendition of the original foreign text without any analytical or editorial comment.

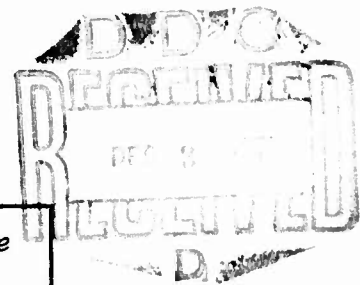

Distribution of this document is unlimited. It may be released to the Clearinghouse, Department of Commerce, for sale to the general public.

Reproduced by
NATIONAL TECHNICAL
INFORMATION SERVICE
Springfield, Va. 22151

TECHNICAL TRANSLATION

FSTC-HT-23-1172-70

ENGLISH TITLE: PRACTICAL AERODYNAMICS OF THE MI-6 HELICOPTER

FOREIGN TITLE: Prakticheskaya Aerodinamika Vertoleti Mi-6

AUTHOR: M. S. Yatsunovich

SOURCE: Moscow Transport, 1969

Translated for FSTC by Techtran Corporation

NOTICE

The contents of this publication have been translated as presented in the original text. No attempt has been made to verify the accuracy of any statement contained herein. This translation is published with a minimum of copy editing and graphics preparation in order to expedite the dissemination of information. Requests for additional copies of this document should be addressed to the Defense Documentation Center, Cameron Station, Alexandria, Virginia, ATTN: TSR-1.

This translation was accomplished from a xerox manuscript. The graphics were not reproducible. An attempt to obtain the original graphics yielded negative results. Thus, this document was published as is, in order to make it available on a timely basis.

TABLE OF CONTENTS

INTRODUCTION	1
CHAPTER 1. General Characteristics of Mi-6 Helicopter	9
§1. Brief Information on the Helicopter	9
§2. Body of the Helicopter	10
The Fuselage	10
Wings	11
Stabilizer	11
§3. Lifting Rotor, Power Plant, Transmission and Control System of the Helicopter	11
Lifting Rotor	11
Power Plant	12
Transmission and Fan Unit	15
Tail Rotor	17
Control of the Helicopter	17
§4. Landing Devices, Systems of the Helicopter and Load Suspension Device	19
Landing Devices	19
Hydraulic System	19
Air System	20
Anti-Icing System	20
Device for External Suspension of Cargo	21
§5. Electrical, Radio, Instrument and Special Equipment	21
Electrical Equipment	21
Radio Equipment	22
Instruments	22
Heating and Ventilation	22
CHAPTER 2. Specifics of the Aerodynamic Lifting System and Fuselage of the Helicopter	24
§6. Geometric Characteristics of the Lifting System	24
Geometric Characteristics of the Lifting Rotor	24
Geometric Characteristics of the Wing	28
§7. Kinematic Characteristics of Lifting Rotor	29
Rotating Speed of Lifting Rotor and Linear Speeds of Blade Tips	29
Characteristics of Flying Regimes	31
Blade Joints	31
Elimination of Noncoaxiality of Lift Rotor	35
§8. Aerodynamic Characteristics of the Lifting Rotor	39
Aerodynamic Characteristics of Blade Profiles	39

INTRODUCTION

In recent years, gas turbine engines have been replacing piston engines not only in airplanes, but in helicopters as well. The installation of a high power, low weight engine essentially improves the weight performance of a helicopter and makes it more economical.

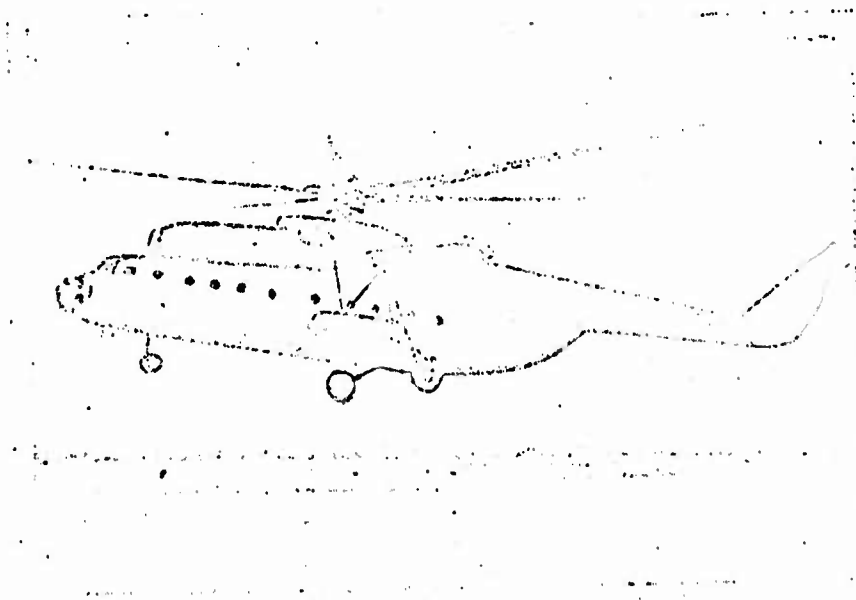

NOT REPRODUCIBLE

Figure 1. The Mi-6 Helicopter.

The Mi-6 helicopter (Figure 1) is the first winged helicopter in the Soviet Union with a gas turbine engine. It was created in 1957, and series production was begun in 1958. It is the heaviest helicopter in the world, its maximum flying weight being 42.5 tons, its normal flying weight being 40.5 tons. It has become widely used in civil aviation, and is exported to many socialist countries and a few capitalist countries.

This helicopter has established a number of world records. Ship Commander R. Kaprelyan lifted a payload of 12,004 kg to a height of 2,432 m in the Mi-6 helicopter in 1957, breaking the world record which had belonged to the USA, and in 1959, lifted a payload of 10,000 kg to a height of 4,855 m, thus breaking his own world record once more.

On 21 November 1959, the Mi-6 established the absolute world's record for speed -- 262.92 km/hr, which had earlier belonged to the USA.

In 1961, Pilot N. Leshin established a new world speed record in the helicopter -- 320 km/hr over a 15-25 km course.

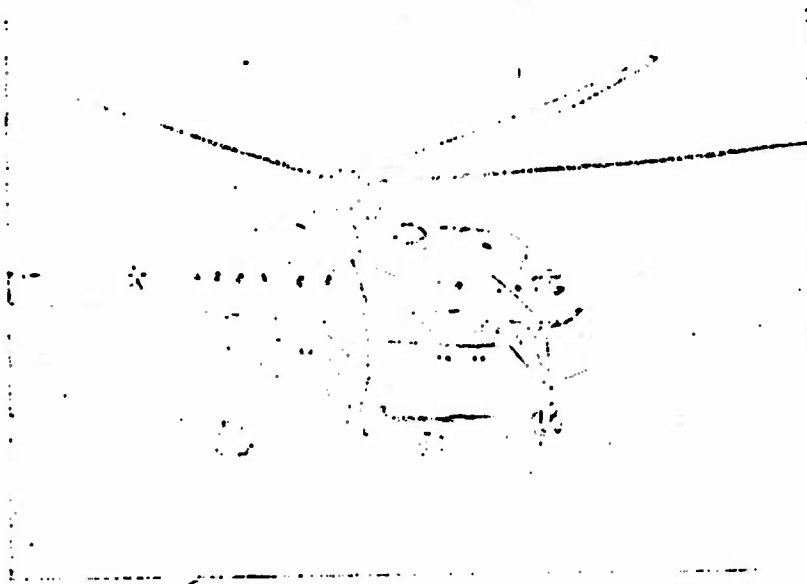

Figure 2. The Mi-10 Helicopter.

NOT REPRODUCIBLE

In September of 1962, the Mi-6 helicopter established 11 new world records. On 11 September 1962, a crew led by Ship Commander V. Koloshenko flew a 1,000 km closed course with a 5,140 kg payload in the helicopter at an average speed of 284 km/hr, thus establishing four world's records: the record for speed over this course length and the record for 1,000 km flights with payloads of 1, 2 and 5 T; on 13 September 1962, a crew led by Ship Commander R. Kaprelyan lifted a payload of 20,117 kg to a height of 2,700 m, thus establishing three world's records: lifting a payload of 20,117 kg to a height of 2,000 m, and lifting loads of 15 and 20 T to a height of 2.7 km. On 15 September, a crew led by Ship Commander B. K. Galitskiy flew closed 500 and 1,000 km courses with payloads of over 2 T at an average speed of 300.377 km/hr over the 1,000 km course and 315.652 km/hr over the 500 km course, establishing four world's records: speeds without cargoes over the 500 and 1,000 km closed courses and speed over a 1,000 km closed course with payloads of 1 and 2 T.

In September 1966, the Mi-6 helicopter established a new absolute world's speed record, which still stands today: the crew of Ship Commander B. K. Galitskiy flew a closed 100 km course at an average speed of 340 km/hr. In 1960, the Mi-10 helicopter (Figure 2) was constructed on the basis of the Mi-6 helicopter. This machine is a "flying crane," with high undercarriage to allow it to carry large cargoes suspended externally. The helicopter can land directly over the cargo placed on a special platform.

The platform is attached using hydraulic clamps to four standard ball joints and the cargo can thus be prepared for lifting in 2 to 3 minutes.

The flying weight of the Mi-10 helicopter is 43,070 kg, the maximum permissible payload is 12 T, the flying range with this payload is 250 km. The maximum range with the main and auxiliary fuel tanks full is 630 km, the cruising speed with the unloaded platform is 220 km/hr, with the platform loaded -- 180 km/hr indicated air speed.

The Mi-10 helicopter, like the Mi-6 helicopter, carries two turbine engines designed by P. A. Solov'yev, with 5,500 horsepower each.

Using the Mi-10 helicopter, on 28 May 1965, Pilot G. Alferov lifted a commercial cargo of 25,105 kg to an altitude of 2,840 m, thus establishing two absolute world records: the maximum height of 2,840 m reached with a cargo of 25,000 kg, and the maximum cargo of 25,105 kg lifted to a height of 2,000 m. On 26 May 1965, a crew directed by Master of Sports V. Kologasenko reached a height of 7,151 m in this helicopter with a cargo of 20,000 kg.

The Mi-10 helicopter was shown to representatives of foreign governments and firms at Vnukovo [airport -- tr] in May 1965 and at the Paris International Air and Space Show that same summer.

The Mi-10K helicopter, a lightened design with ordinary undercarriage (short legs) (Figure 3) was created on the basis of the Mi-10 helicopter in 1965. This helicopter is designed as a "flying crane" for the performance of construction and installation work. Due to its lightened design, its load carrying capacity is two to three T greater than the Mi-10.

The Mi-10K has an additional transparent cabin with separate controls located beneath the fuselage of the helicopter for the performance of construction and installation work by the pilot without an operator and flight leader, thus increasing the productivity and economy of operations.

Under the leadership of M. L. Mil', the Mi-2 helicopter with two GTD-350 turboprop engines, designed by S. P. Izotov, was created in 1961 (Figure 4). The Mi-2 helicopter is a multipurpose machine. Its passenger variant has a comfortable eight passenger cabin, low level

of vibrations and good sound insulation. In the agricultural version, the helicopter carries two tanks with up to 900 kg of chemicals. In the medical version, the Mi-2 helicopter can carry externally attached loads. The flying weight of the helicopter is 3,550 kg. With the main tank filled (600 l) the flight range is: for the passenger version -- 280 km, or with the auxiliary tanks (2 x 238 l) filled -- 597 km. The maximum speed at an altitude of 500 m for the passenger version is 210 km/hr, for the agricultural version -- 155 km/hr. The cruising speed of the passenger version at 500 m is 205 km/hr, of the agricultural version -- 155 km/hr. The ceiling of the helicopter is 4,000 m. The minimum vertical speed of the passenger version with autorotation is 8 m/sec, of the agricultural version -- 8.5 m/sec.

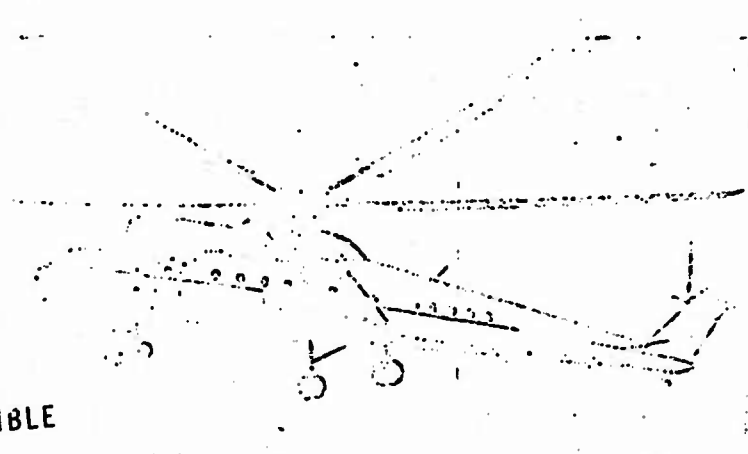

NOT REPRODUCIBLE

Figure 3. The Mi-10K Helicopter.

The helicopter can maintain constant altitude with one engine, assuring flight safety.

Due to the gas turbine engines, the high quality of planning and the usage of new materials, this helicopter has high weight performance, high economy and equals the best foreign helicopters in all indicators.

In May of 1963, Test Pilot B. A. Anopov and Chief Engineer of the State Scientific Research Institute for Helicopter Aviation L. L. Babadzhanova established a world speed record for helicopters in weight category IV in the Mi-2 helicopter: 254.337 km/hr over a 100 km course.

In 1961, under the leadership of General Designer M. L. Mil', the Mi-8 helicopter with one turbine engine was created on the basis of the Mi-4 helicopter. Then, in 1962, two TV2-117 turbine engines designed by S. P. Izotov, with 1,500 horsepower each, were installed on this helicopter, as well as a 21.288 m diameter five-bladed lifting rotor (Figure 5).

The maximum power of the engines is retained up to an altitude of 4,000 m. In the design of this helicopter, the latest world achievements of science and technology in the area of helicopter construction were considered, so that it greatly exceeds the Mi-4 helicopter in its flying properties, economy and other indicators. The maximum weight of the helicopter is 12,000 kg, its normal weight is 11,100 kg. The maximum speed is 250 km/hr, the cruising speed is 225 km/hr. The ceiling of the helicopter at its normal flying weight is 4,500 m, at its maximum weight -- 4,000 m. The maximum commercial cargo is 4,000 kg, and at maximum weight the flight range is 100 km; with a payload of 3,000 kg, the flight range is 400 km. With the usage of auxiliary fuel tanks (installed in the cabin), the maximum range can be increased to 700 km with a payload of 2,000 kg.

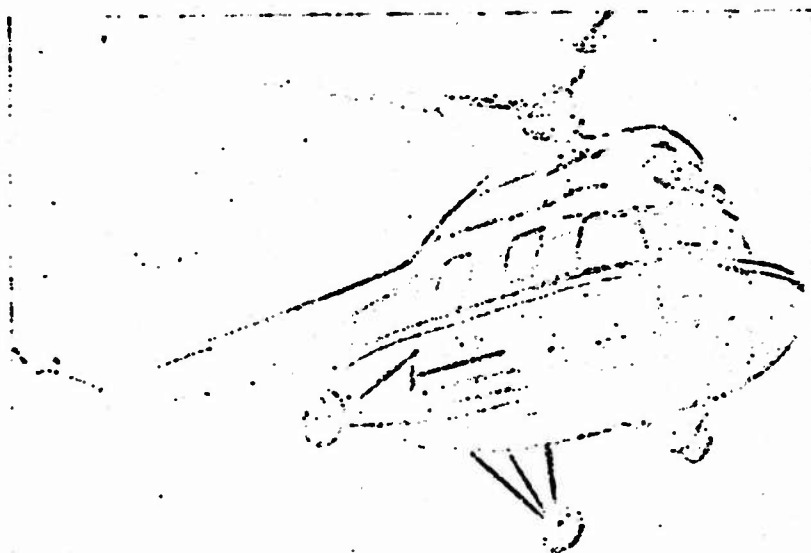

NOT REPRODUCIBLE

Figure 4. The Mi-2 Helicopter.

The helicopter is economical, simple to service and operate, has an air conditioning, heating and ventilation system, low level of vibration and a spacious cockpit with good visibility; complete reliability is assured. The helicopter carries the AP-34B four channel autopilot, which stabilizes the helicopter in flight in pitch, bank, course and altitude. The helicopter also carries a modern set of navigation instruments. All of this allows the helicopter to be used at all latitudes at night and under poor weather conditions, including icing conditions.

On 19 April 1964, a crew under the command of Ship Commander V. P. Koloshenko established two absolute world records in the Mi-8 helicopter:

the record of range over a closed course of 2,465.736 km and the speed record over a 2,000 km course -- 201.834 km/hr.

NOT REPRODUCIBLE

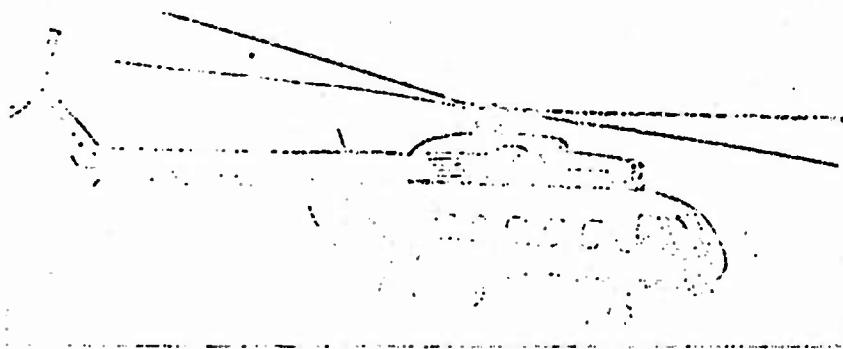

Figure 5. The Mi-8 Helicopter.

The Mi-8 helicopter was shown to representatives of foreign governments and firms at Vnukovo in May of 1965, and at the Paris International Air and Space Show that same summer it was acknowledged as the equal of the best contemporary foreign models and competitive on the world market.

In 1967, three women's world's records were established in the Mi-8 helicopter: flight over a 500 km closed course at 273 km/hr, over a 1,000 km closed course at 258 km/hr and over a 2,084 km closed course at 258 km/hr.

A team headed by Lenin Prize Laureate, Doctor of Technical Sciences N. I. Kamov also designs gas turbine powered helicopters. This team designed the Ka-22 heavy combined helicopter-winged aircraft (Figure 6). This is a heavy aircraft with two powerful gas turbine engines (5900 horsepower each) placed transversely on the wings. Each engine powers two rotors: one is the lifting rotor designed to maintain the lifting force, while the other is a puller propeller to create thrust during forward flight. A rotor-winged aircraft has an advantage over helicopters, since it flies at positive angles of attack, has less drag and fuel consumption and longer flying range. At the end of 1961, a world's speed record over a 15-25 km course of 356.3 km/hr was set by the Ka-22. This same year, a Ka-22 established world records for lifting commercial loads of 1,000, 2,000, 5,000, 10,000 and 15,000 kg to an altitude of 2,588 m and a world record for lifting the maximum cargo to a height of 2,000 m -- 16,485 kg.

This design bureau has also created the multipurpose Ka-26 helicopter, using coaxial rotors. One distinguishing feature of this

helicopter is that the central portion of the machine, located beneath the lifting rotors, carries no structures at all. Various types of equipment can be attached here depending on the application: an apparatus for airborne spray operations, a platform (Figure 7) for transportation of cargo, a removable six passenger cabin, or a winch for transport of externally supported cargo. This makes this helicopter a true multipurpose design.



Figure 6. N. I. Kamov-Designed Ka-22 Rotor-Winged Aircraft. NOT REPRODUCIBLE

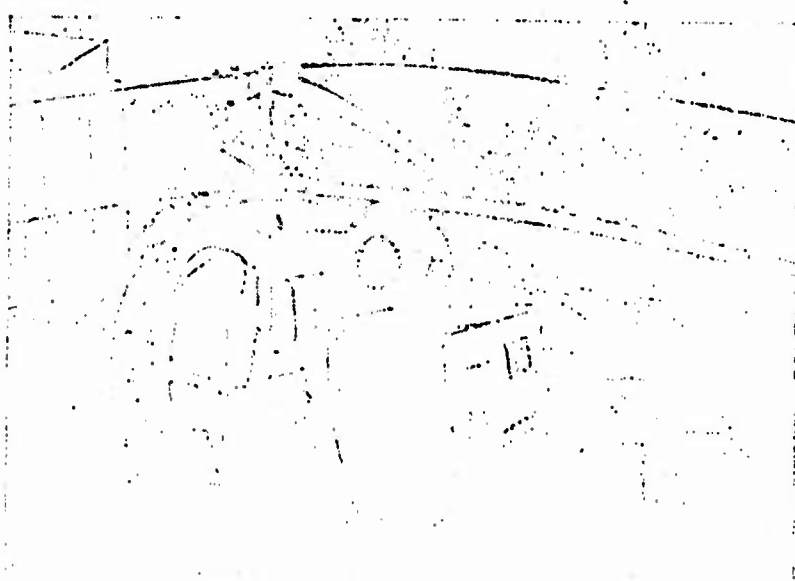

Figure 7. The Ka-26 Helicopter. Next to The Helicopter We See The Passengers Cabin And Platform With Cargo. The Helicopter Carries Spraying Equipment.

This helicopter carries two M-14V26 325 horsepower air cooled, nine cylinder radial piston engines.

The crew of the helicopter consists of the pilot alone.

The helicopter can be used in the following main versions: cargo-passenger, medical, agricultural with sprayers, agricultural with duster, cargo with platform and as a "flying crane."

Switching the helicopter from one version to another is done by an operating team (2-4 men in 1-3 hours) using standard equipment and tools.

CHAPTER 1. GENERAL CHARACTERISTICS OF MI-6 HELICOPTER

51. Brief Information on the Helicopter.

The Mi-6 helicopter with two D-25V turboprop engines is a single lifting rotor helicopter with a tail rotor. The lifting rotor is a five-bladed all-metal structure, while the tail rotor is a four-bladed rotor with wood blades. Early models carry a lifting rotor with trapezoidal blades, while later models of the helicopter carry lifting rotors with rectangular blades. Due to its design specifics, the lifting rotor with rectangular blades has better aerodynamic properties, and creates more thrust with the same power consumption.

NOT REPRODUCIBLE

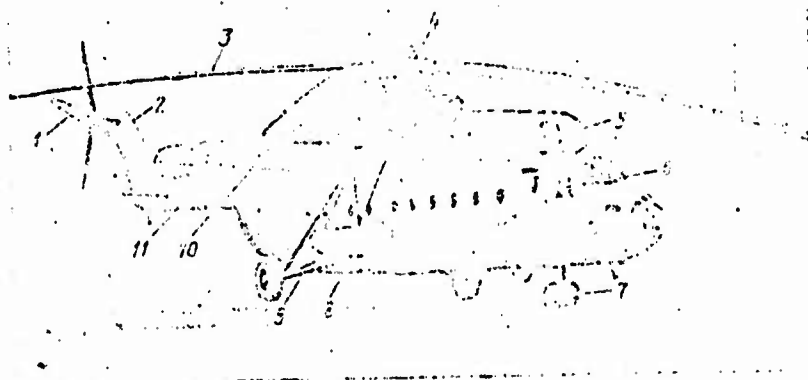

Figure 8. The Mi-6 Helicopter:

1, tail rotor; 2, tip beam; 3, lifting rotor blade; 4, lifting rotor hub; 5, D-25V engines; 6, crew's cockpit; 7, forward landing gear; 8, suspended tank; 9, main landing gear; 10, wing; 11, tail tank.

The Mi-6 helicopter consists of the following main units and systems: fuselage, wing, stabilizer, lifting rotor, power plant, transmission and

ventilator installation, control system, tail rotor, landing system, hydraulic system, air system, anti-icing system, device for external suspension of cargo, electric-radio-instrument system and special equipment (Figure 8).

52. Body of the Helicopter

The Fuselage

The fuselage of the Mi-6 helicopter is a riveted, all metal structure, consisting of stringers, ribs and duraluminum sheathing of varying thickness. It consists of four parts: the nose, central, tail and tip beams.

The nose portion of the fuselage contains the crew's cockpit and most of the equipment.

The central portion of the fuselage contains the engine and reducing gear sections, load-carrying cabin and fuel tank compartments. The floor of the load-carrying cabin is a force-accepting structure. Beneath the floor are the containers for eight fuel tanks; the remaining three fuel tanks are placed in containers over the ceiling of the load-carrying cabin. The engine and reducing gear compartments are placed above the load-carrying cabin. At the end of the cabin are valves and the cargo gangways. The cabin has one door on the right side, two doors on the left side, and a central hatch with flaps in the floor.

The tail beam is a duraluminum riveted structure consisting of ribs, stringers and sheathing. The beam is joined to the central portion of the fuselage at rib No. 42. Within the beam are the tail shaft of the transmission, the pedal control cables and the stabilizer fastening units.

The tip beam is a continuation of the tail beam angled upward at 47° to the axis of the tail beam. The lower portion of the tip beam contains the intermediate reducing drive, while the upper portion contains the tail reducing drive, with the tail rotor mounted onto its shaft. The tip beam consists of three parts: the keel beam, fixed rudder and removable fairing. The keel beam consists of an inclined longeron, ribs and duraluminum sheathing. The fixed rudder consists of ribs, a longitudinal assembly (angle sections), overlapping strips and sheathing. The ribs have an asymmetrical shape, so that in forward flight the rudder creates an aerodynamic force directed in the direction of thrust of the tail rotor, thereby unloading the tail rotor. On the side of the tail rotor, the fixed rudder is covered with a duraluminum sheet, while on the opposite side it is covered with linen. The upper portion of the rudder on the left side carries the vents for exhausting the air which cools the intermediate reducing gear. The rudder is fastened to the keel beam with screws and self-locking nuts. The removable fairing is a duraluminum framework fastened to the keel beam and fixed to the rudder with screws and self-locking nuts. The fairing is removed to provide access to the intermediate reducing gear and a fastener for the shock absorbing upright of the tail support.

Wings

The helicopter carries a cantilever wing with a 15.3 m span and an area of 35 m². The angle of setting of the right cantilever is 15° 45", of the left -- 14° 15".

The wing consists of a wing center section beam and the right and left cantilever beams attached to it. Each wing cantilever consists of a framework and sheathing. The framework includes a longeron, stringers and ribs. The wing center beam is of box cross section, riveted up of thin duraluminum sheeting. The upper and lower walls are reinforced with stringers and connected with longitudinal profiles. The beam passes between ribs No. 18 and 19 of the fuselage and is articulated to two fastening units on rib 18. The lower front units of the beam carry two counter-units.

The portion of the wing which is heated by exhaust gases is protected by a special heat resistant steel screen. The screen is mounted on angle brackets made of a material with low heat conductivity and fastened by bolts and anchor nuts. There is a clearance between the screen and the wing sheathing for the passage of air. A fairing is provided for smooth attachment of the wing to the fuselage.

Stabilizer

The Mi-6 helicopter carries a stabilizer which can be controlled in flight to provide the necessary controllability and stability. The control of the angle of the stabilizer is combined with the "pitch-gas" lever: when the lever is moved upward, the angle of the stabilizer is increased, when it is moved downward -- it is decreased. The stabilizer has a symmetrical NACA-0012 profile and consists of left and right halves, located symmetrically relative to the tail beam. The two halves are connected by a longeron. Each half of the stabilizer (cantilever beam) consists of a longeron, set of ribs, diaphragms, duraluminum front sheathing, tail stringer, tip fairing and linen skin. The stabilizer includes two units for fastening to the tail beam and one unit for fastening the stabilizer control line. The area of the stabilizer is 4.87 m². The angle of deflection relative to the datum line is 5 ± 1° upward, 13 ± 1° downward.

§3. Lifting Rotor, Power Plant, Transmission and Control System of Helicopter

Lifting Rotor

The lifting rotor of the helicopter consists of a hub and five blades. The hub is mounted on the shaft of the main reducing gear system. Each blade is fastened to the hub by three articulated joints: the horizontal, vertical and axial (longitudinal) joints. The blade performs gyration

movement around the horizontal joint, oscillates in the plane of rotation around the vertical joint and changes its angle of setting by rotating around the axial joint. The gyration movement of the blade around the horizontal joint is kinematically related to the rotation of the blade around the axial joint by means of the swing regulator (compensator): as the blades swing upward, the angle of setting is decreased, and as they swing downward it is increased. Thus, the swing compensator increases the stability of motion of the blades and improves other characteristics of the helicopter. The vertical joints of the blades include hydraulic shock absorbers installed in the hub.

The blades of the rotor are all-metal structures, the load accepting element being a steel tubular longeron, to which 26 sections are connected, which are not rigidly connected to each other. Therefore, when the blades bend, the sections do not interact with each other, merely transmitting the aerodynamic and inertial forces directly to the blade longeron.

In 1965, a new rectangular blade was created with a constant chord of 1,000 mm. The load accepting element of the new blade is also a steel longeron, and all-metal cold-rolled tube of variable cross section 15,610 mm in length. The blade frame, consisting of 20 sections, is fastened to the longeron by special fastening units. The sections transmit the aerodynamic forces to the longeron; each section consists of a nose and a tail portion. The tail portion has a honeycomb filler. The rectangular blade also has a geometric twist. In this blade, the longeron is sealed and has a system for signaling damage. The lifting rotor has a diameter of 35 m, both with the trapezoidal and with the rectangular blades.

Both blades include electrical anti-icing devices.

Power Plant

Two type D-25V 5500 horsepower turboprop engines are located above the cabin, symmetrically relative to the longitudinal axis of the fuselage, tilted downward at 5° in relation to the axis. The engines are fastened to the fuselage through brackets and adjustable uprights with rubber shock absorbers. The two engines operate independently of each other, allowing flight to be continued with one engine in operation when necessary.

One specific feature of the D-25V engine is the fact that it includes a free turbine, not kinematically connected to the turbine-compressor portion of the engine. The rotating speed of this turbine can be established independently of the operating mode of the turbine-compressor portion of the engine. This provides a number of design and operational advantages: it allows the desired rotating speed of the lifting rotor to be set as a function of the flight altitude and regimes, regardless of the rotating speed of the turbine-compressor section of the engine, improves fuel consumption under various operating conditions of the engine, makes starting of the engine easier, and eliminates the necessity for a mechanical clutch in the power plant of the helicopter.

The engine consists of the following main units and systems:

- compressor intake body with drive transmissions of units;
- nine stage (eight stage for first series of engines) axial compressor with air bypass after stages III and IV of compressor and perforated cavity above first stage of compressor; air is automatically bypassed through apertures covered by bypass strips;
- ring-tube combustion chamber with twelve flame tubes;
- single stage turbine for compressor drive;
- two stage turbine operating through reducer to drive helicopter lifting rotor;
- transmission to transmit torque from two stage turbine to reducing drive;
- fuel supply system and automatic engine control system;
- automatic starting system with starter generator;
- lubricating and prompting system;
- engine fire extinguishing system;
- exhaust pipe.

The operating principle of the engine is as follows (Figure 9). Air from the atmosphere is sucked in through a special passage and intake body 1 of the compressor by the nine stage compressor, compressed in it and passed on to combustion chamber 4. A portion of the air entering the combustion chamber participates in burning of the fuel, while the main portion of the air is mixed with the hot gases, thus reducing the temperature of the gases to the required level before they enter the turbine. From the combustion chamber, the flow of hot gases enters the turbine. In single stage turbine 5 of the compressor, a portion of the energy of the hot gases (about 50%) is converted to mechanical energy, expended in rotation of the rotor of the compressor and the various units. The remaining portion of the energy of the hot gases is converted in two stage free turbine 6 of the rotor into mechanical work, which is transmitted through transmission 10 and main reducer 12 to shaft 13 of the lifting rotor. The energy of the gas stream leaving the rotor turbine makes up about 7% of the energy converted to useful power, and is expended in the creation of reactive thrust by the engine.

The engine is equipped with an automatic starting system using a starter generator which is fed by on board batteries or on ground power supplies, and an automatic system for adjustment of fuel supply depending on the operating mode of the engine and of the flying regime of the helicopter. Control of all starting operations is automatic. The engine is controlled using a single lever, installed on an NR-23A pump regulator.

Each engine has a welded exhaust pipe 9 in an internal passage in order to carry the spent gases out to the atmosphere. The transmission of the engine, connecting the free turbine shaft to the main reducing gears pass through this passage as well. The outside of the exhaust pipe carries a cover with shaped sections welded to the inside, forming spiral channels to direct the air flow which cools the exhaust pipe.

NOT REPRODUCIBLE

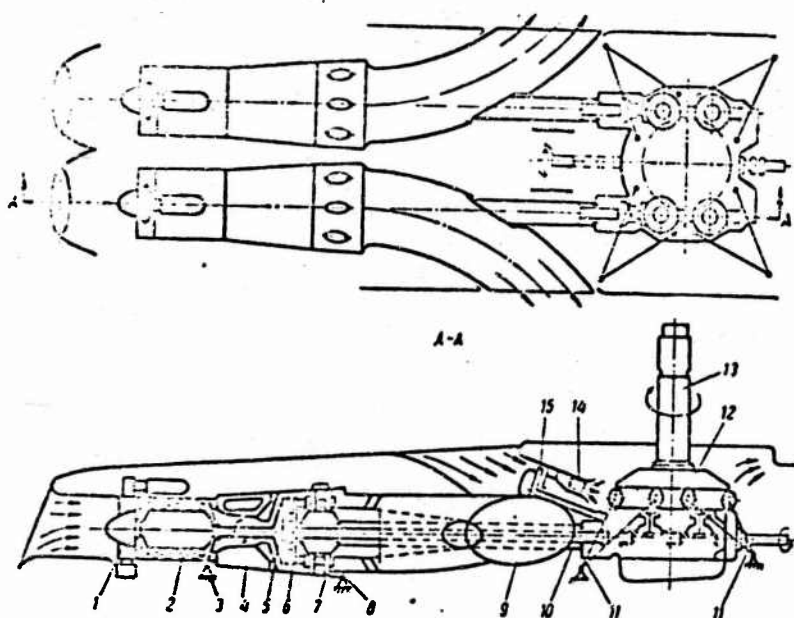

Figure 9. Diagram of Power Plant of Mi-6 Helicopter:
1, compressor intake body; 2, compressor; 3, front motor support;
4, combustion chamber; 5, compressor turbine; 6, free turbine
(rotor turbine); 7, body of rotor turbine; 8, rear engine support;
9, exhaust pipe; 10, transmission; 11, reducing gear fastening
points; 12, main reducing gear; 13, lifting rotor shaft; 14,
radiator; 15, fan.

Above and behind the engines, in the space between the exhaust pipes is a fan 15 driven by the main reducer. The air from the fan blows over the oil radiators, and some of this air is directed through pipes to the exhaust pipes, to the main reducer and to the engine units which require forced cooling.

The fuel is carried in eleven flexible tanks, divided into five groups.

The total capacity of the main tank is 8150 l. The capacity of the two suspended tanks is 4500 l (2250 l each).

Each group of tanks, as well as the reserve tanks, carry electric fuel pumps to move the fuel and create the required pressure before the engine pumps. Fuel level pickups are installed to measure the level of fuel in the tanks. Furthermore, the helicopter can carry two additional suspended tanks

on the sides of the fuselage and two more identical tanks inside the cabin. The fuel from the suspended tanks flows by gravity into tank No. 7. Any group of tanks can be filled from the tanks inside the helicopter by using the on board fuel filler while on the ground; in flight, fuel can be fed from these tanks only into tank No. 11.

Expenditure of fuel from the tanks and the sequence of switching pumps is automatically controlled using the SETS-230A fuel level meter which is designed so as to retain the operational centering of the helicopter within permissible limits. Any fuel pump can be turned on or off manually, and the order of usage of fuel from the tanks can be manually changed.

A neutral gas is used in the fuel system, supplied by three eight liter carbon dioxide tanks mounted above the ceiling of the cabin.

The motor, main reducer and fuel tank compartments are equipped with a fire extinguishing system which operates automatically in response to signals from heat sensors.

The power plant of the helicopter has an oil system for the compressor portion of the engines and an oil system for the main reducer, free turbines and transmissions. The oil system for the compressor portion of the engines consists in turn of two independent oil systems, so that in case of failure of one system the other can supply its engine. Each of the oil systems consists of an oil tank, radiator and system of oil lines.

The oil system for the main reducer and free turbines consists of two oil radiators, two bypass valves and lines. The oil for this system is carried in the crankcase of the main reducer.

The engines, fan and main reducer are covered by a single hood. The hood consists of air collectors, a front compartment, firewalls, fan and reducing compartments and a rear fairing. In the future, it is planned to place hoods over each engine for convenience in servicing and in order to reduce the volume of work required for the replacement of one engine. In order to protect the air collectors from icing, electric heaters are mounted in the nose portion of each collector. The oil tanks of the compressor portion of the engines are placed between the internal and external fairings of the air collectors on mounts. In order to increase the convenience of access in servicing the engines, reducer and fan, there are ladders and tilting covers, opened and closed by the hydraulic system, on the right and left sides of the hood.

Transmission and Fan Unit

The transmission of the helicopter is designed for the transmission of the power from the free turbines to the lifting and tail rotors and to the fan. The transmission consists of the main, intermediate and tail

reducers, the tail and tip shafts, the lifting rotor brake and the fan drive. The main reducer decreases the rotating speed of the free turbine and transmits the torque from the engines to the lifting rotor, tail shaft and fan installation. Furthermore, the reducer has four drives for hydraulic pumps, two drives for the generators of the anti-icing system, two drives for tachometer pickups and two spare drives.

The lifting rotor brake with expanding shoes, the drum of which is connected to a flange on the tail shaft, is fastened to the rear of the main reducer body. The brake is used to slow down the entire transmission including the rotors when the helicopter is parked.

The main reducer and free turbines have an independent oil system. The total quantity of oil in the main reducer and its oil system is 260 l.

The tail shaft is used to transmit torque from the main reducer to the tail reducer through the intermediate reducer. The shaft consists of eleven links, nine of which are carried on eight mounts to the intermediate reducer, two of which are mounted between the intermediate and tail reducers with a single support. The tail shaft link carries a splined joint, which compensates for possible inaccuracies in the setting of the mounts and eliminates the influence of elastic and temperature deformations.

The intermediate reducer transmits the torque from the main reducer to the tail reducer, decreases the rotating speed and changes the direction of the tail shaft. Bevel gears with spiral teeth allow the tail shaft to be set at an angle of 47° upward. The intermediate reducer has two lubricating systems: the main system with forced oil circulation and a duplicate bubbling system to lubricate the bearings in case of failure of the main system. Seven liters of oil are poured into the reducer. The intermediate reducer is fastened to mounts on a rib in the tip beam by four lugs on the reducer case.

The tail reducer transmits the torque from the intermediate reducer to the tail rotor and reduces the rotating speed. This reducer has one pair of bevel gears with special teeth. The reducer includes the pitch control mechanism for the tail rotor. The tail reducer has an independent oil system -- a primary system with forced oil supply and a duplicate bubbling system. Twenty-six liters of oil are poured into this reducer.

The fan is used to cool the following units: oil radiators of engines and main reducer, DC and AC generators, air compressor, hydraulic pumps, engine exhaust pipes, and also to force air into the helicopter cabin ventilating system. The fan drive is from the main reducer through a cardan shaft. The quantity of air passing through the ventilator can be adjusted by changing the setting angle of the blades of the directing apparatus using a special mechanism.

Tail Rotor

The helicopter carries an AV-63B variable pitch tail rotor 6.3 m in diameter. The tail rotor balances the reactive torque of the lifting rotor, controls the direction of the helicopter and provides directional stability. The rotor is installed on the shaft of the tail reducer using involute splines. The pitch of the tail rotor is controlled by pedals from the pilot's cockpit. The maximum pitch is 23° with the right pedal against the stop, and the minimum pitch is 9° with the left pedal against the stop. With the pedals in the neutral position, the pitch of the tail rotor is 4° [sic -- tr]. The tail rotor is reversible: in flight with the engines operating it is a pusher, since its thrust is directed to the left, while in the autorotation mode of the lifting rotor it is a puller, with its thrust directed to the right. The tail rotor has four blades, which are wooden with metal binding. The blades have axial joints in order to change the pitch of the rotor and horizontal joints for gyrating motion. The installation of vertical joints on the blades is being considered for the future.

Control of the Helicopter

Control of the helicopter relative to the three axes is achieved by changing the magnitude and direction of thrust of the lifting rotor and changing the magnitude of thrust of the tail rotor. Longitudinal and transverse control is by the cyclical pitch level 2 (Figure 10) through the automatic skew device, a deflection of which changes the inclination of the aerodynamic force of the rotor. Directional control is by the pedals 1, which operate by changing the pitch of the tail rotor.

In order to create the necessary forces on the control lever and pedals, and in order to unload them from constant forces in various flight regimes, the hand and foot control systems include spring loading mechanisms (trimmers) 3, 9 and 10. Control of these mechanisms with manual flight control is by a switch operating through the MP-100M 8 electrical mechanism. This switch is located at the top of the lever. With foot control, the electrical mechanism is switched on by the terminal switches and buttons installed on the pedal support areas.

The aerodynamic force of the lifting rotor and engine power are changed using the "pitch-gas" lever 4. Control of the stabilizer is combined with the "pitch-gas" lever: when the pitch is reduced, the setting angle of the stabilizer is reduced and vice-versa. In addition to the combined control of engines and lifting rotor pitch with the "pitch-gas" lever, separate control of the engines is provided, that is, each engine can be tested without changing the pitch of the rotor, and the necessary operating mode can be set for flight with one engine out of operation.

The helicopter has dual control, basically a rigid construction, independently by each pilot. The tail rotor and stabilizer use cable control in the tail portion of the fuselage and the tail beam. The control system

includes two-chamber non-reversible hydraulic pumps. The helicopter carries a three channel type AP-31 autopilot, stabilizing the flight of the helicopter in bank, pitch and course. The autopilot operates only on the main hydraulic system, is automatically disconnected in case of failure and the control of the hydraulic amplifier is shifted to manual control by the back-up hydraulic system.

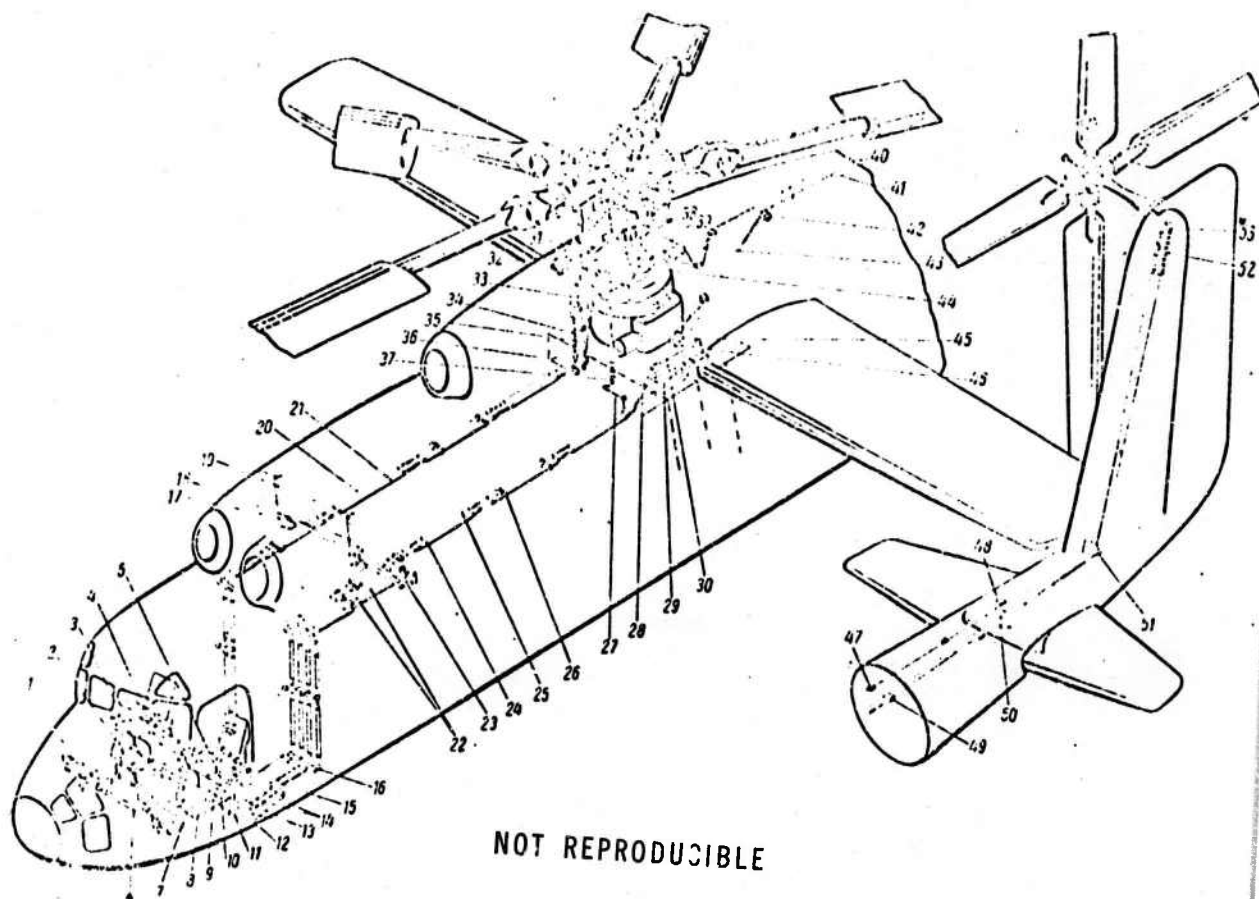

Figure 10. Control Diagram of Mi-6 Helicopter.
 1, foot control pedal; 2, cyclical pitch lever; 3, spring mechanism for loading longitudinal control mechanism; 4, "pitch-gas" lever; 5, 19, motor control levers; 6, 30, 39, 44, 50, tension members; 7, hinged link; 8, MP-10GM electrical mechanism; 9, spring mechanism; 10, spring mechanism loading foot controls; 11, 21, pitch control line; 12, 13, 14, 18, 22, engine control cables; 15, 17, differentials; 16, rocker with adjustable stops; 20, longitudinal control lines; 23, engine control rocker unit; 24, foot control line; 25, transverse control lines; 26, guide rollers; 27, 36, rockers; 28, 34, 35, 37, lines with spring devices; 29, foot control hydraulic amplifier; 32, longitudinal control hydraulic amplifier; 33, pitch control hydraulic amplifier; 38, unit connecting stabilizer control to automatic skew slide; 40, stabilizer control lines; 41, foot control lines; 42, 51, rollers; 43, sector; 45, drum; 46, multiplier; 47, 49, textolite guides; 48, stabilizer control mechanism; 52, roller chain; 53, sprocket.

§4. Landing Devices, Systems of the Helicopter and Load Suspension Device

Landing Devices

The landing devices of the helicopter include the three point, non-retracting landing gear and tail support with liquid-gas shock absorbers. The track of the main landing gear wheels is 7.5 m, the wheel base is 9.005 m. The parking angle is -2° (datum line of helicopter tilted forward and downward).

The front landing gear is located on the axis of symmetry of the helicopter and fastened to mounts on rib No. 1 of the central portion of the fuselage. It has two nonbraked turnable 720 x 310 mm wheels. The tire pressure is 6 kg/cm^2 for both wheels.

The main landing gear are a pyramid type, consisting of half axles, rear supports and dual chamber shock absorbers, fastened to mounts on ribs No. 18 and 22 of the central portion of the fuselage. The half axles of the main legs of the landing gear carry brake drums measuring 1325 x 480 mm. The initial pressure in the tires is 7 kg/cm^2 . The wheel brakes use single action cylinders. The wheels are braked by means of the pneumatic system of the helicopter. The high pressure chamber system of the landing gear legs contains a spring-shock absorber unit with lines connecting it to the high pressure chambers.

The tail support protects the tail rotor and tail beam from accidentally contacting the ground as the helicopter is landed. It consists of a shock absorber, two supports and a foot.

The shock absorbers use type AMG-10 fluid, totaling about 64 l, including: in the two high pressure shock absorbers 40 l, in the two low pressure shock absorbers 9.6 l, in the front shock absorbers 6 l, in the tail support shock absorbers 2.25 l, in the spring-shock absorber unit and lines -- 6 l. The initial nitrogen pressure in the shock absorbers is: high pressure chambers on main landing gear 48 kg/cm^2 , low pressure chambers -- 14 kg/cm^2 , front landing gear 27 kg/cm^2 and tail support 60 kg/cm^2 .

Hydraulic System

The hydraulic system of the helicopter consists of the main, backup and supplementary systems. The main and backup system are used to supply all hydraulic amplifiers in the control system. The supplementary system operates the windshield wipers, unblocks the "pitch-gas" lever, adjusts the height and back tilt of the pilots' seats, automatically closes the

fan blades in case of a fire in the reducer compartment and operates the external lifting wench. On the ground, this system opens and closes the cargo flaps and hatches as well as the access hatches in the hood.

The main, backup and supplementary system pumps are installed on the drive lines of the main reducer, assuring normal operation of the system in case of engine failure and transition of the helicopter into the lifting rotor autorotation mode.

The hydraulic system operates using AMG-10 fluid at a working pressure of 120-155 kg/cm², with the temperature of the surrounding medium from 60 to -50° C. The fluid enters the hydraulic system from a hydraulic tank, separated by a baffle into two cavities, each of which feeds the main and duplicate systems separately. The supplementary system is supplied from the upper portion of the backup system tank cavity.

The main system has two NSH-2S hydraulic pumps, while the backup and supplementary systems have one each. Each system has a hydraulic accumulator, an automatic pump unloading device (GA-77), coarse and fine filters, a manometer, electric valve and other units. The hydraulic accumulators of all three systems are filled with technical nitrogen.

The total quantity of fluid in the hydraulic system is about 120 l, including 55 l in each side of the hydraulic fluid tank.

The hydraulic system provides for duplicate operation of all units in the control system with the exception of the autopilot.

Air System

The air system of the helicopter is used to brake the wheels of the main landing gear, control the air bypass system from the compressors of the engines and control the valves of the hot air lines in the cabin heating system. Compressed air is carried at a pressure of 50 kg/cm² in cylinders, using the cavities in the upper portion of the main landing gear shock absorbers as cylinders. These cylinders are filled with air by an AK-50T compressor installed on the left engine. On the ground, the cylinders are filled by compressed air from cylinders at the airport through an external filling nozzle on a special air system panel.

Anti-icing System

The anti-icing system is designed to protect the helicopter from icing. Anti-icing devices are carried on the blades of the lifting and tail rotors, in the front ends of the air intake collectors and in the glass of the pilot's and navigator's compartments. All anti-icing devices, except for the anti-icing device of the tail rotor, are electric heating devices. The blades

of the lifting rotor have ice ejecting deicers which operate cyclically, and the air intakes and pilot's and navigator's compartment windows have constantly heated deicers preventing the formation of ice. The blades of the tail rotor have a liquid anti-icing system.

The anti-icing devices are powered by 280 v three phase AC. This current is supplied by two SGS-90/360 generators. The helicopter has a system signaling the beginning of icing.

Device for External Suspension of Cargo

The helicopter is equipped with a special device designed for fastening and transportation of large cargoes suspended outside. For this purpose, a special girder is installed in the cabin above the central hatch, carrying a hydraulic clamp. Barriers are placed around the hatch inside the cabin for safety, and a ring is installed in the bottom of the fuselage to prevent the cable from pressing against the sides of the hatch. Loads are lifted and lowered using a LPG-3 wench installed in the front portion of the cabin.

Depending on the conditions, loads may be hooked up with the helicopter landed beside the load or with the helicopter hovering over the load. Hook-up of a load with the helicopter hovering over it can be performed using a coupling hitch or by direct attachment of the brackets of the suspension system to the hook of the main cable, which is attached to the hydraulic clamp. This latter method provides the most rapid and reliable attachment of cargoes and is therefore recommended for usage if conditions permit.

When necessary, a load may be released in flight. In order to insure reliable operation of the load releasing system, control of the opening of the swivel clamp is separate: two electrical devices are used with normal and emergency release wires. A normal release is achieved by pressing on the "normal release" button on the "pitch-gas" lever. If the normal release system does not operate (failure of the device or the wire), an emergency release can be performed by pressing on the "emergency release" button of the "pitch-gas" lever of the left pilot. In case of a failure of the electrical and hydraulic system, the load can be released by the manual emergency release system, which is done by the operator. This requires that the "release" lever be rotated to its downward position and that the swivel clamp be opened by moving the emergency opening lever downward, without removing the shock absorber from this lever.

§5. Electrical, Radio, Instrument and Special Equipment

Electrical Equipment

The electrical equipment of the Mi-6 helicopter provides for normal operation of the piloting and navigational apparatus, engine operation

indicator instruments, radio devices, signal apparatus, lights, engine starting system, anti-icing devices, fire extinguishing system, electrical equipment of hydraulic system and operation of the electrical mechanisms and electrical cranes.

The helicopter carries both AC and DC power supplies. DC power is supplied by the two type STG-12TM starter generators and two type 12SAM-55 batteries, each consisting of two half-batteries, carried in four containers. The DC electrical system consists of the main, emergency and accumulator systems.

The AC power supply on board the helicopter consists of two type SGS-90/360 three phase generators of 90 kw each, operating at 360 v. The navigational and radio equipment is supplied with alternating current using PO-1500, PT-500TS, PAG-1FP and PO-250 inverters. The AC and DC electric power supplies are controlled from the flight engineer's control panel.

Radio Equipment

The radio equipment installed on the helicopter consists of two main groups: the radio communications and radio navigation equipment. The radio communications equipment includes the 1-RSB-70 (R-807) radio set with the US-9 receiver, the command radio set and the SPU-7 intercom system. The radio navigation equipment includes the ARK-5 automatic radio compass, the RV-2 radio altimeter and the marker radio receiver.

The power supply to the radio apparatus is by 27 v AC and by a single-phase AC circuit at 115 v through the PO-1500 inverter. In case of failure of the main power supply of the PO-1500, it can be switched manually to AC supplied by the SGS-90/360 generators through reducing transformers.

Instruments

The helicopter is equipped with a full set of piloting and navigational instruments, instruments for engine operation and instruments to test the operation of individual systems, allowing piloting and navigation problems to be solved for day and night flying under all weather conditions. The indicators of the various instruments and apparatus are placed on control panels and at the working positions of the pilots, navigator, radio operator, flight engineer and medical worker.

Heating and Ventilation

The helicopter carries a forced air heating and ventilating system for the cockpit and cabin. The heating system is a dual circuit type. Hot air from the sleeves around the engine exhaust pipes passes through two

air-air radiators and heats cold air pumped to the radiators from the cargo cabin or from the external atmosphere. The heated air is then returned to the cabin and cockpit. The quantity of warm air fed into the cockpit can be adjusted by each member of the crew.

The heating system lines can be used to ventilate the cockpit and cabin. Furthermore, the cabin is ventilated by air pumped in by the fan. The air is distributed by a special box to the ventilating devices on both sides of the fuselage. Type DV-3 fans are included for local air circulation at the pilots, navigator, flight engineer and radio operator positions.

CHAPTER II. SPECIFICS OF THE AERODYNAMIC LIFTING SYSTEM AND FUSELAGE OF THE HELICOPTER

§6. Geometric Characteristics of the Lifting System

Geometric Characteristics of the Lifting Rotor

Diameter. Although the Mi-6 helicopter has high flying weight, its rotor diameter is relatively small, only 35 m. We know that the required diameter of a lifting rotor for a helicopter can be determined from the formula

$$D = \sqrt{\frac{4G}{\pi P}}$$

As we can see from the formula, the diameter of the lifting rotor of a helicopter for a fixed weight can be decreased only by increasing the specific load. It is not suitable to make a large diameter rotor, since this leads to an even greater increase in the weight of the lifting system and decreases the weight performance of the helicopter.

The blade profile is an important geometric characteristic of the lifting rotor. In the Mi-6 helicopter various profiles are used along the length of the blade in order to improve the aerodynamic characteristics of the lifting rotor and improve the flying and other properties of the helicopter.

The trapezoidal blade has the NACA-230M profile from sectors 2 to 20, and the special TSAGI P-57-9 high speed profile from sectors 22 to 27. Sector 21 is a transitional section (NACA-230M profile merges smoothly with the TSAGI P-57-9 profile).

In the rectangular blades, sections 1-17 have the NACA-230M profile, sections 19 and 20 (end of the blade) have the TSAGI P-57-9 profile, while section 18 is the transitional section.

The end portions of the blades have the high speed profile since they move at greater linear velocities than the blades of other helicopters. For example, even at the minimum permissible rotating speed of the lifting rotor (78% on the rpm indicator, or 113 rpm of the lifting rotor) the linear speed of the end of the blade is 207 m/sec, and at the maximum permissible rotating speed (90% on the rpm indicator, briefly, or 130 rpm of the lifting rotor) the linear speed of the end of each blade reaches 238 m/sec.

Profile P-57-9 has a high critical M number (M_{cr}) in comparison to the NACA-230M profile. For example, whereas for the NACA-230M profile with an angle of attack for 0 lifting force $M_{cr} = 0.72$, or with $C_y = 0.6$, $M_{cr} = 0.64$, with the P-57-9 profile the critical M numbers are 0.772 and 0.665 respectively. Therefore, if the blade operates at angles of attack corresponding to $C_y = 0.6$, the critical speed when flying near the earth under normal atmospheric conditions will be

$$V_{cr} = \alpha \cdot 0.665 = 341.1 \times 0.665 = 227 \text{ m/sec.}$$

Consequently, at less than 227 m/sec, shock waves and additional drag will not appear.

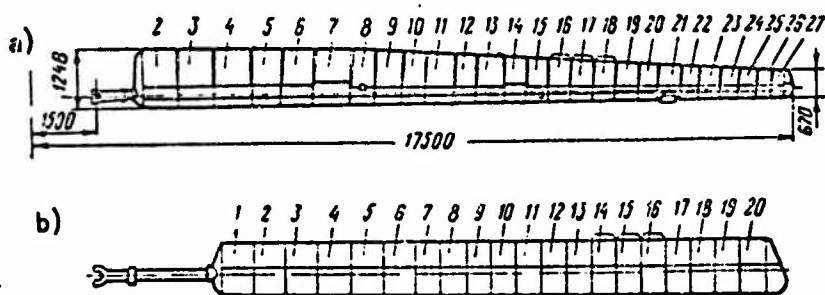

Figure 11. Plan Form of Blades.
a, Trapezoidal; b, Rectangular.

With the lifting rotor operating between the minimum permissible speed and the speed recommended for all flight regimes (78-83%), the linear speeds of rotor tips will be 207 to 220 m/sec, which is beneath the critical speed (227 m/sec). At higher rotating speeds or in forward flight, the air flow speed around the blades at azimuth 90° will be higher, and at high altitudes the critical speed will decrease as a result in the decrease of the speed of sound; therefore, under these conditions the flow around the blade tips will be supercritical, compression jumps and additional drag will appear, which must be considered in aerodynamic calculation of the power consumption for flight of the helicopter (the "compressibility" phenomenon).

Blade form in plan. The Mi-6 helicopter uses blades which are trapezoidal in plan and new blades which are rectangular in plan. The trapezoidal blade consists of 26 individual sections (2 through 27) fastened to a steel longeron by special fasteners. The base portion of the blade from sections 2 to 7 (from $r = 2.650$ m to $r = 7.480$ m) has a rectangular form in plan with a chord of 1.248 m, while the end portion from sections 8 through 26 has a trapezoidal form with the minimum chord at the theoretical tip section of 0.62 m (Figure 11a).

The rectangular blade consists of 20 separate sections. The chord of the blade is 1 m in length (Figure 11b). A rectangular blade is poorer in the aerodynamic respect than a trapezoidal blade with otherwise equivalent geometric parameters. However in this case the rectangular blade is superior in other geometric parameters (e.g., relative profile thickness, geometric twist) to the trapezoidal blade, which improves its aerodynamic characteristics.

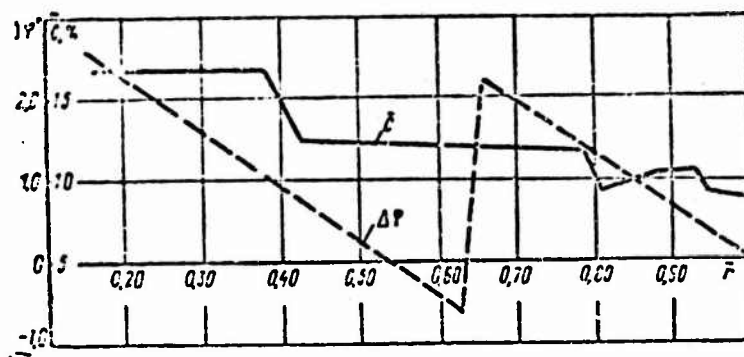

Figure 12. Geometric twist ($\Delta\phi$) and relative thickness ($c\%$) of trapezoidal blade of Mi-6 helicopter lifting rotor as a function of r .

Geometric twist of blade. For the trapezoidal blade, the geometric twist is provided as follows. At section No. 2 ($r = 2.650$ m), the twist angle is greatest -- $2^\circ 38'$, then it decreases linearly to $0^\circ 35'$ in section 14, after which it increases once more to $2^\circ 13'$ in section No. 15 and subsequently decreases linearly to 0° at the end of the theoretical cross section. The stepped change in twist angles is provided to decrease dynamic stresses in the longeron of the blade (Figure 12).

In the rectangular blade, the twist is equal to $5^\circ 48'$, following a linear rule of change without steps (Figure 13). This great twist significantly improves the aerodynamic properties and flying characteristics of the helicopter: the lifting force is more evenly distributed over the length of the blade, a general increase in the thrust of the blade is achieved, power assumption for rotation of the blade is decreased and the maximum flight speed is increased.

8

The relative thickness of the blades, both trapezoidal and rectangular, decreases toward the end of the blade, which improves the aerodynamic qualities of the rotor by increasing the critical speed and M_{cr} of the blade tips, which in turn decreases the torque consumed by the rotor.

The relative thickness of the trapezoidal blade at the base is 17%; it decreases by stages toward the tip of the blade, reaching 9% at the 27th section. The relative thickness of the rectangular blade at sections 1 and 2 is 17.5%, at sections 4, 5 and 6 is 14.5%, at sections 8-17 is 13% and at sections 19-20 is 11%. Sections 3, 7 and 18 are transitional (Figure 13).

NOT REPRODUCIBLE

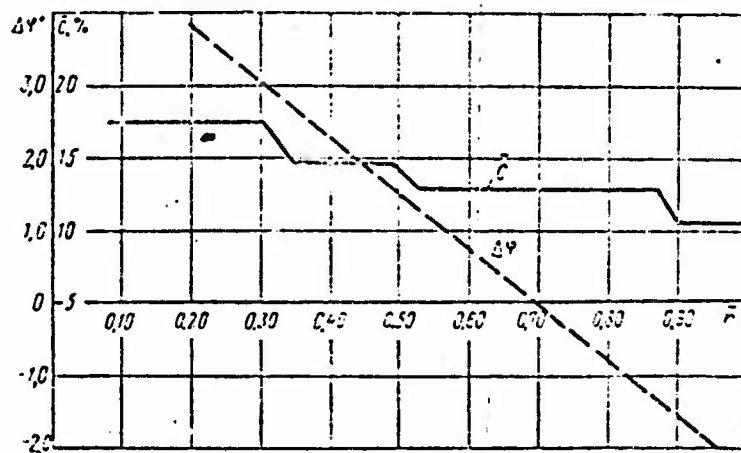

Figure 13. Geometric Twist ($\Delta\phi$) And Relative Thickness (c%) of Rectangular Blade of Lifting Rotor of Mi-6 Helicopter as a Function of r.

The specific load on the area swept by the blade. The specific load influences the vertical speed in the autorotation mode and the thrust per unit power. The higher the specific load, the greater the vertical speed in autorotation. Consequently, it is good to have low specific load. The less the specific load over the swept area, the greater the thrust of the lifting rotor per unit power, since

$$\frac{T}{N} = \frac{1}{\sqrt{P}}$$

from which

$$T = \frac{N}{\sqrt{P}}$$

The lifting rotors of helicopters have relatively low specific loads; therefore, they develop high specific thrust per unit of power (4-6 kg per hp), whereas airplane propellers, with high specific loads, develop low specific thrust (about 1.5 kg per hp). Consequently, from this standpoint as well it is good to have low specific load over the swept area. However, this requires a large diameter rotor, which increases the weight of the rotor and decreases the weight performance of the helicopter. Therefore, the Mi-6 helicopter, with a flying weight of 40 T, uses a relatively high specific load over the swept area.

$$P = G/F_{om} = 40,000/960 = 41.7 \text{ kg/m}^2.$$

The filling coefficient of the lifting rotor of the Mi-6 helicopter is higher than that of any other single rotor helicopter; for the trapezoidal blade rotor it is 0.0864, for the rectangular blade rotor it is 0.091. With this filling coefficient, high thrust is created and the required setting angles are reduced, moving flow separation to the area of high speeds.

The setting angle of the blade (pitch of the rotor). As in other helicopters designed by M. L. Mil', the pilot's cockpit in the Mi-6 helicopter carries type USHV-1 indicators showing the pitch of the lifting rotor (for both pilots). The range of change of the rotor pitch is from 1 to 13.5°. The pitch of the lifting rotor indicated by the instrument is an arbitrary number, while the actual angle of the blades, i.e., at a radius of 0.7 R, is 4.75° higher than that shown by the pitch indicator. Therefore, the actual angle at radius 0.7 R will be equal to the setting angle shown on the indicator plus 4.75°. At other blade sections, these numbers will be different, due to the twist of the blade. This lack of correspondence between the setting angle on the pitch indicator and the actual angle creates no difficulties in piloting.

Weight of blades and lifting rotor. All blades of the Mi-6 helicopter weight 3,575 kg, the lifting rotor hub weighs 3,250 kg, the total weight of the lifting rotor is 6,825 kg, 16% of the maximum weight of the helicopter. The weight of the lifting rotor of a modern, single rotor helicopter should be 9 to 15% of the total flying weight of the helicopter. Therefore, increasing the diameter of the lifting rotor or the weight of the helicopter with the same lifting rotor diameter would not be expedient, since it would decrease the weight performance of the helicopter.

Geometric Characteristics of the Wing

The form of the wing in plan is trapezoidal. The wing span is 15.3 m, the base chord is 2.667 m, the tip chord is 1.809 m, the mean aerodynamic chord is 2.35 m. The area of the wing including the portion in the fuselage is 35 m², the aspect ratio is 6.7. The profile of the wing is symmetrical,

type TSAGI P-35-12. The relative thickness of the wing at the base is 15% of the chord, at the tip -- 12%. The wing has two antifrutter loads of 20 kg each, located on the right and left sides at wing rib 32.

The setting angle of the right wing (between the chord of the wing and the plane of rotation of the lifting rotor) is $15^{\circ} 45'$, the angle of the left wing is $14^{\circ} 15'$. The degradation in setting angles of the right and left wings of 1.5° decreases the right bank of the helicopter during forward flight without slipping and increases the transverse reserve of control at high flight speeds. The inductive flow from the lifting rotor passes around the two wings asymmetrically: the flow is more intensive around the left wing, since the inductive flow of the forward moving blades at 90° azimuth is higher than at 270° azimuth. Therefore, a left bank effect is created. This effect was produced by aerodynamic calculation and tests of helicopter models in the wind tunnel.

Therefore, a degradation of angles of setting of the wings opposite to that used was tried. However, flying tests showed the opposite result: large right bank resulting from the high moment of inertia of the hub due to displacement of the horizontal joints.

Up to 1966, the wing on the Mi-6 helicopter was controllable. The setting angles mentioned above were used for flight regimes with operating motors. In the autorotation regime, the wing was shifted to lower angles of setting: for the left wing -- $4^{\circ} 15'$, for the right wing -- $5^{\circ} 45'$. It was found that the flying properties of the helicopter were changed very slightly when gliding using the setting angles designed for flight with the engines operating, and that the stability and controllability were retained. Therefore, in order to simplify the design and increase operating reliability, the wing was fixed rigidly with the setting angles noted above for flight with engines operating.

§7. Kinematic Characteristics of Lifting Rotor

The kinematics of the lifting rotor of the Mi-6 helicopter do not differ in principle from the kinematics of the lifting rotor of the Mi-4 helicopter. The lifting rotor of the Mi-6 helicopter, like that of the Mi-4 helicopter, has articulated blade suspension. In vertical flight regimes and in forward flight, the blades act just like those of the Mi-4 helicopter: they occupy certain positions in the three joints, oscillate around these positions, and form a cone of rotation. A swing regulator is included.

However, there are certain specific differences in the kinematics of the Mi-6 helicopter lifting rotor, which we will discuss.

Rotating Speed of Lifting Rotor and Linear Speeds of Blade Tips

As we established earlier, the free turbine of the engine has no kinematic connection to the turbine-compressor portion of the engine; both

turbines are driven by the stream of hot gases from the combustion chambers. The rotating speed of the compressor turbine varies from the minimal idling speed (5500 ± 100 rpm) to the maximum speed in the takeoff regimes at 3,000 m altitude (10,580 rpm) (measured)¹. The ITF-2 compressor speed indicator is set in the left panel of the pilot's instrument panel and is duplicated on the instrument panel of the flight engineer. The scale of the device is graduated in percentages of the compressor rotating speed from 0 to 100. 10,640 rpm of the compressor is taken as 100%, so that 1% is equal to 106.4 rpm. Consequently, according to the indicator the minimum permissible rotating speed is $51.5 \pm 1\%$, the maximum permissible speed is 99.5%.

At the idle, the rotor turbine develops 3400-4000 rpm, and in all other modes, including the takeoff mode, it develops 7800-8300 rpm, with speeds of 9000 rpm permitted briefly. The ITE-1 free turbine (lifting rotor) rotating speed indicator also shows the speed in percentages. In this case, 1% corresponds to 100 rpm of the rotor turbine, so that no conversions are required. Then the minimum rotating speed of the rotor at the idle is 34-40%, the normal speed in all regimes is 78-83% and the maximum permissible rotor speed is 90%. The rotating speed indicators for the free turbine are installed on the left and right panels of the pilot's instrument panel.

The main reducer decreases the rotating speed of the free turbine by 69.2 times, so that the actual rotating speed of the lifting rotor, i.e., for the minimum permissible speed of operation in all modes is: $7800:69.2 = 113$ rpm, the maximum permissible speed is $8300:69.2 = 120$ rpm and the maximum (brief) speed is $9000:69.2 = 130$ rpm.

The linear speed of the tip of the lifting rotor blade is determined from the following formula:

$$U = \omega R = \pi n_B / 30 R,$$

where ω is the angular speed;

R is the radius of the lifting rotor;

n_B is the rotating speed of the lifting rotor in rpm.

The linear speed of the blade tip of the rotor at 113 rpm (78% on the indicator) is:

$$U = 3.14 \cdot 113 / 30 \cdot 17.5 = 207 \text{ m/sec.}$$

¹Data for D-25V second series engine, Serial No. S3422014.

Correspondingly, at 120 rpm (83%) the tip speed is 220 m/sec, and at 125 rpm (87%) it is 229 m/sec, and at the maximum briefly permissible speed of 90%, it is 238 m/sec.

Characteristics of Flying Regimes

In aerodynamic calculations for the Mi-6 helicopter, relative speeds are used: the flying regime characteristic μ and the flow factor λ . Although these velocities are not used in flying practice, they cannot be avoided in an analysis of many problems of practical aerodynamics.

The flying regime characteristic is the ratio of the flight speed of the helicopter to the linear speed of the blade tip of the lifting rotor or the ratio of the diameter of the reverse flow zone to the rotor radius

$$\mu = V \cos A / \omega R \approx V / \omega R = d/R.$$

For the Mi-6 helicopter in the hovering mode $\mu = 0$, and at the maximum forward speed it is 0.4. Therefore, the flying speed of the helicopter will be $V = \mu \omega R$.

For the recommended maximum speed of the lifting rotor with trapezoidal blades at all flight modes up to 3,000 m altitude (83% on the indicator) the linear speed of the blade tip is 220 m/sec. Each value of flight regime characteristic corresponds to a given flight speed:

$$\mu = 0.05 - 40 \text{ km/hr};$$

$$\mu = 0.25 - 200 \text{ km/hr};$$

$$\mu = 0.10 - 80 \text{ km/hr};$$

$$\mu = 0.30 - 240 \text{ km/hr};$$

$$\mu = 0.15 - 120 \text{ km/hr};$$

$$\mu = 0.35 - 280 \text{ km/hr};$$

$$\mu = 0.20 - 160 \text{ km/hr};$$

$$\mu = 0.40 - 320 \text{ km/hr}.$$

Consequently, we can consider that on the average an increase in the flight regime characteristic by 0.05 corresponds to an increase in flight speed of 40 km/hr.

Blade Joints

The horizontal blade joint of the Mi-6 helicopter has the same purpose as the horizontal joint in the Mi-4 helicopter. The possible maximum swing angle of the blade upward (upper horizontal joint stop) is 25° , the

hanging angle with the support on the bracket is 7° (rotating speed of lifting rotor over 70-80 rpm), with the support on the dog of the centrifugal limiter -- $2^\circ 10'$ (rotating speed of lifting rotor over 70-80 rpm)¹. The spread of the horizontal joints is 400 mm (dimension b, Figure 14).

The centers of the lugs in the lifting rotor hub are displaced relative to the axis of rotation forward in the direction of rotation by distance a, which is 85 mm for the Mi-6 helicopter. Therefore, the horizontal joint is rotated relative to the radial direction by angle $\gamma = 6^\circ$. Distance a, and therefore angle γ , are selected such that in the principal flight modes the resultant force N, blade drag X and centrifugal force F_{cf} of the blade are directed along the axis O_1O_2 . In this case, even distribution of loads is provided between the needle bearings (M and H) of the horizontal joint, their durability is increased and the forces on the thrust bearings of the joint are decreased.

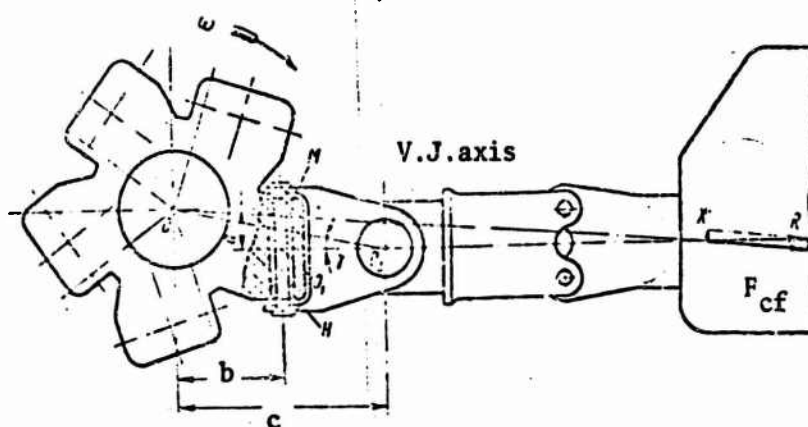

Figure 14. The Horizontal Joint.

Swing Regulator. The blades perform gyrating motion around the horizontal joints both due to cyclical changes in the pitch of the lifting rotor upon deflection of the automatic skew mechanism, and due to the asymmetrical field of velocities and aerodynamic forces on the swept surface during forward flight. Due to the gyrations of the blades during forward flight, the axis of the cone of rotation of the lifting rotor and its aerodynamic force are deflected to the rear and to the left. The Mi-6 helicopter includes a swing regulator with a characteristic of 0.4. Due

¹Centrifugal hanging limiter mechanism operates on acceleration at 80 rpm, upon deceleration at 70 rpm.

to this swing regulator, the blade performs oscillations about the axial joint, i.e., the setting angle of the blade changes: with an upward swing, the setting angle decreases, with downward swing it increases. The change in the setting angle $\Delta\phi$ in this case will be equal to the product of the swing angle β times the characteristic of the swing regulator K :

$$\Delta\phi = \beta K.$$

The swing regulator changes the direction of drop of the angle of the cone of rotation and its aerodynamic force: they now drop away to the rear and right. The drop away to the right creates a side force, balancing the thrust of the tail rotor.

Gyrating movement coefficients. As we know from the general aerodynamics of a single rotor helicopter, the magnitude of gyrating motion is characterized by the gyrating motion coefficients, which determine the drop of the axis of the cone to the rear (a_1) and right (b_1) of the shaft axis. These coefficients are shown on Figure 15 for the Mi-6 helicopter in horizontal flight as a function of the flight regime characteristic. As we can see from the figure, the axis of the cone of rotation drops to the rear at cruising speeds ($\mu = 0.25-0.30$) by 8° , and to the right by an angle of over 3° , while at maximum in horizontal flight the axis of the cone of rotation will drop away even more strongly.

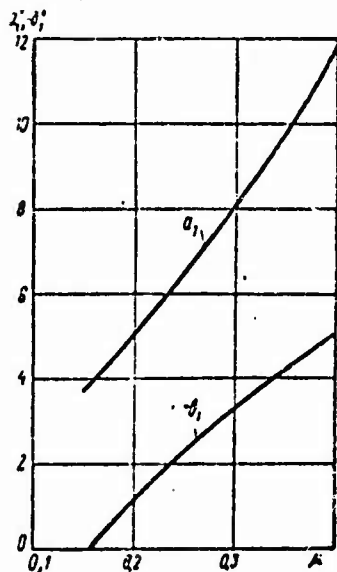

Figure 15. Gyrating Motion Coefficients as a Function of Characteristic of Forward Flight Regimes: a_1 , drop of cone of rotation to the rear; b_1 , drop of cone of rotation to the right.

Moment of inertia of hub due to span of h.j. If the cone of rotation of the lifting rotor is not deflected, the centrifugal forces of the blades

are directed parallel to the base of the cone of rotation and create no moments (Figure 16a). If the cone of rotation is deflected using the cyclical pitch lever or due to angle flow over the blades during forward flight, a centrifugal force moment is created on the hub, directed in the direction of the deflection of the axis of the cone of rotation. When the axis of the cone of rotation drops away by angle α_1 (Figure 16b), the centrifugal forces of the blades F_{cf} will be directed in parallel to the axis of the base of the cone, arm c will be set up between them and the hub moment $M_h = F_{cf}c$ arises.

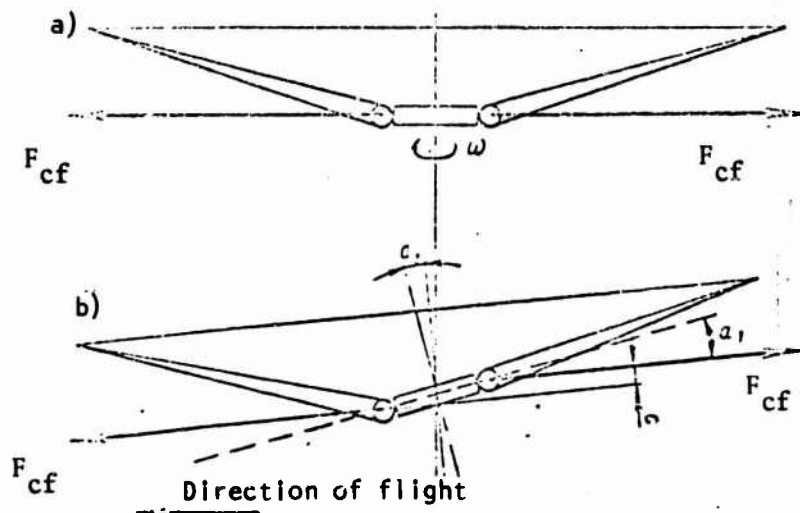

Figure 16. Moment of Inertia of Hub Due to Spread of Horizontal Joint.

The greater the spread of the horizontal joints and the drop of the cone of rotation, the greater will be the hub moment. The moment will be longitudinal if the cone of rotation moves in the horizontal plane, and transverse if it moves in the transverse plane. The longitudinal hub moment is directed in the direction of movement of the cone (to the rear) during forward flight and is a pitching moment, the transverse moment of the hub during forward flight is also directed in the direction of movement of the cone of rotation (to the right) and gives the helicopter a right bank. The same moments arise when the equilibrium of the body of the helicopter relative to the cone of rotation is disrupted, but in this case they are damping moments and prevent further disruption of equilibrium, providing a certain static stability to the helicopter in both the longitudinal and transverse directions.

Vertical and axial joints. The blades of the Mi-6 helicopter have vertical and axial joints in addition to the horizontal joint. The blade can move around the vertical joint forward in the direction of rotation by

14° (front stop of V.J.) or backward by 18° (rear stop of V.J.) from the perpendicular to the axis of the horizontal joint. The vertical joints of the Mi-6 helicopter have hydraulic dampers, which have more stable characteristics, lower weight and simpler servicing and operation than friction dampers. A helicopter with hydraulic dampers of the vertical joints is less subject to "ground resonance" since the moment of friction in these dampers does not remain constant as in friction dampers, but rather increases with increasing oscillating amplitude. The spread of the vertical joint is greater than spread b of the horizontal joint (See Figure 14).

The axial joints of the blade allow their setting angles to be changed in order to change the lifting force. The setting angles are changed for all blades by the same quantity by changing the general pitch of the lifting rotor, and they also change continually due to the cyclical change in the pitch of the rotor and under the influence of the swing regulator.

Elimination of Noncoaxiality of Lift Rotor

Determination of the noncoaxiality of the lifting rotor of the Mi-6 helicopter is performed by photographing the blades during operation of the rotor on the ground and in flight using a special camera. The relative position of the images of the tips of the blades on the film indicates the required adjustment to provide coaxiality of rotation of the rotor blades. We will analyze here operations on elimination of noncoaxiality of the lift rotor when the rectangular blades are used. This work consists of the following stages: preparation of the helicopter for photography, ground preparation of the lift rotor, photography of the blades in flight, processing of the film and analysis of the results of flight photography and, finally, adjustment of the lift rotor blades.

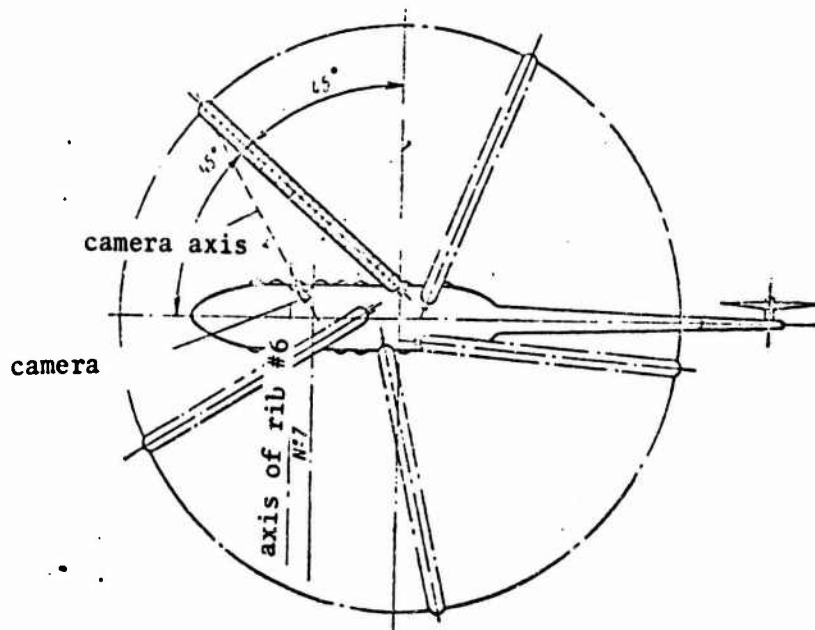

Figure 17. Diagram of Placement of Camera in Horizontal Plane.

Preparation for photography. A special flag plate which is included with the camera is placed on two bolts on blade No. 1 (in section 14). The length of the plate is 160 mm, the width is 60 mm. Placement of this flag is required to allow distinction of blade No. 1 on the film. After locating the image of blade No. 1, the other blades forming the remaining images can be determined by counting.

The camera and bracket are installed on the right side in the cabin inside the third blister. It is adjusted in the horizontal plane so that its lens is directed at the end of blade No. 1, set on the right side facing forward at an angle of 45° to the longitudinal and the transverse axes of the helicopter (Figure 17).

Ground preparation of lift rotor. If a new set of blades is being installed on a helicopter, the preliminary setting of the bodies of the axial joints is performed by adjusting the length of the blade rotating tension members to identical length (320 ± 1 mm between lower end of upper fork rest and upper end of lower fork nut). The flaps should have an initial mean bend angle for each blade of 2° downward from the lower surface of the blade.¹

The mean angle of bend of the flaps for a given blade is determined using the formula

$$\delta_{bl.av} = \delta_{fl.1av} + \delta_{fl.2av} + \delta_{fl.3av}/3$$

The mean angle of bend of each flap (e.g., No. 1)² is determined by the actual angles (A, B, C) measured in three cross sections: the end near the base of the blade, middle and near the tip of the blade:

$$\delta_{fl.1av} = A + B + C/3.$$

In this case the angle of bend of the flap sections (A, B, C) is positive if the reading is taken on the sector of the angle measuring device scale located above the zero; it is negative if the angle is read on the scale sector located below the zero.

¹The angle of bend is determined by a special angle measuring device, and the flap is bent with a special tool.

²Each blade carries three flaps; the one located nearest the base of the blade is considered the first flap.

If a set of blades is being installed on the helicopter which has been operated and adjusted earlier on another helicopter, the tension member lengths and flap bending angles should correspond to those written in the documentation accompanying the blades.

Photography of the blades on the ground should be performed in calm weather or with a wind speed of not over 4 m/sec, with the helicopter loaded to normal flying weight or pulled down.

After this preparation, the engine is started and warmed up. A general pitch of the lift rotor of 5° is set, and the rotating speed of the free turbine is set at 78%. The camera is pointed and fixed in the vertical direction so that the tips of the blades as they rotate pass at the level of $1/3$ height of the viewer from its upper edge. With the engine operating mode stabilized and without touching the control devices, on the command of the person performing the start up and testing of the engines, the start button of the camera is depressed for 5-6 seconds to make the pictures.

Then the motors are stopped, the film cassettes are removed from the camera, developed and dried. The pictures are used to determine the deviation from conical travel of the rotor blades. Each millimeter of displacement of the tips of the blades on the film corresponds to a vertical displacement of the blade tip of approximately 45 mm. The relative displacement of the ends of the blades (deviation from conical path) should not exceed 1.5 mm on the film, corresponding to an actual displacement of 70 mm. If the deviation from conical path exceeds these limits, it must be eliminated as follows: the blade (or group of blades) which is seen on the film above the "base" blade has a higher angle of setting, so that the tension member on this blade should be shortened; a blade whose end passes below the "base" line has a lower angle of setting, so that its adjusting tension member should be lengthened. In order to move the end of a blade by 1 mm on the film, its tension member must be rotated by three faces.

As soon as the deviation from the conical path is eliminated, the same test of conicity must be performed by photographing the blades with the free turbine rotating at 83% with the same general pitch -- 5° .

Photography of blades in flight. The photography of the blades in flight is performed after all of the adjustment work described above is performed on the ground.

Photography is performed in a stable horizontal flying regime at 300-500 m altitude with the free turbine rotating at 79%, with indicated flight speeds of 150, 200 and 300 km/hr. Flight must be performed in quiet atmosphere. During photography, all control levers should be left unmoved. The camera is turned on in stable horizontal flight at one of the speeds mentioned above for 2 seconds, then photography is repeated for the other speeds.

Processing of film and analysis of results of photography. The dried film is laid out so that the images of the blade tips are downward, with the blade bases upward, with the beginning of the film on the left, the end of the film on the right, so that the vertical displacement of the tips of the blades on the film is in the same direction as their actual displacement, and counting of the blades is performed from right to left (Figure 18a). The flight regimes are also indicated on the film and the flag is used to find blade No. 1.

The location of the blade tips on the film produced by ground photography or in flight at the extreme regimes ($V = 150$ and 300 km/hr) is used to determine the "base" blade or group of blades, which are selected so as to provide for the minimum required adjustment. The tips of the "base" blade (blade No. 5 on Figure 18a) are accurately connected by straight lines through each revolution. The displacement of the tips of the other blades relative to these lines is determined.

Based on the displacements of the tips of the other blades from the "base" blade in millimeters, a graph of deflection is constructed as a function of flight speed (Figure 19). This graph is used to select the most efficient version of adjustment: in the example presented here, all blades had to be adjusted to reduce their deflection from "base" blade No. 5. The graph is also used to determine the deflection of each blade in the speed range from 150 to 300 km/hr. If the deflection of a blade tip throughout the entire speed range does not exceed ± 0.5 mm relative to the tip of the "base" blade, this blade need not be adjusted (blade No. 1). If the deflection of the tip of the blade throughout the entire speed range remains unchanged or increases with increasing speed and is 10-20% higher at 300 km/hr than at 150 km/hr, these blades are adjusted only by changing the length of the blade control tension member (blades No. 3 and 4). If the difference is greater than 10-20%, the blades must be adjusted for low speed by changing the lengths of the tension members, and for high speed by bending the flaps. If the blade is found to "run through" the area, that is, at 150 km/hr the blade tip is above the "base" line, while at 300 km/hr it is below the "base" line (blade No. 2) or vice versa, this blade must be adjusted by bending the flaps and changing the length of the tension member.

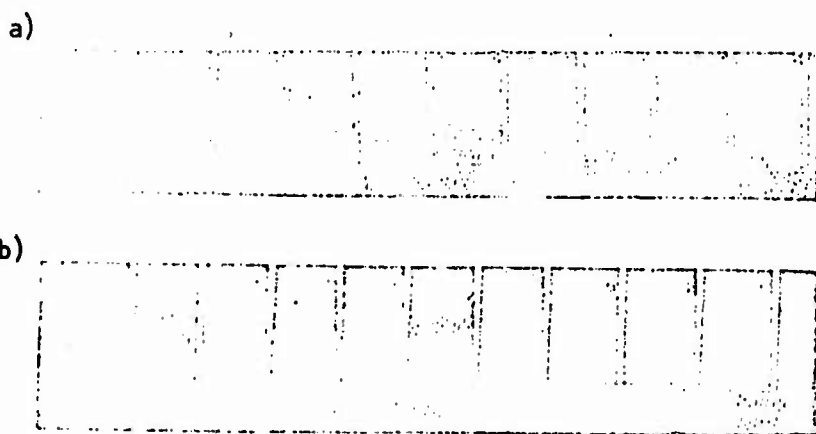

NOT REPRODUCIBLE

Figure 18. Samples of Film:

a, nonadjusted lifting rotor; b, adjusted lifting rotor.

NOT REPRODUCIBLE

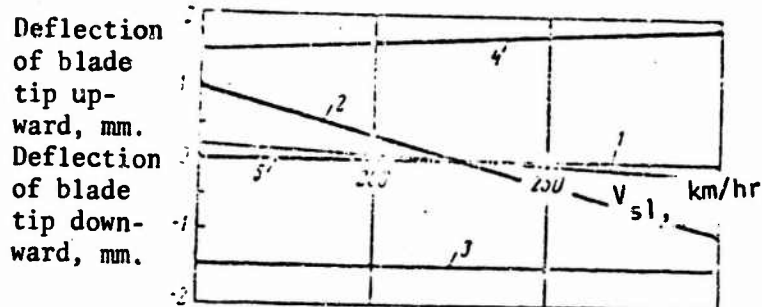

Figure 19. Graph of Deflection of Blade Tips of Lifting Rotor Based on Results of Photography in Horizontal Flight: 1, Blade No. 1; 2, Blade No. 2; 3, Blade No. 3; 4, Blade No. 4; 5, Blade No. 5 ("base").

Adjustment of lifting rotor blades is performed by changing the lengths of the control tension members of the blades and by bending the flaps. One rotation of the tension member changes its length by 3 mm, which changes the setting angle by $0^{\circ} 27'$, displacing the end of the blade at 150-300 km/hr by 90-100 mm on natural scale, corresponding to 2 mm on the film. Changing the angle of deflection of the flaps by 0.5° displaces the end of the blade by 20-25 mm when flying at 150 km/hr (0.5 mm on the film) and by 40-50 mm when flying at 300 km/hr (1 mm on the film).

During the process of adjustment of conicity of the lifting rotor, the limiting permissible mean bending angles of the flaps should be within $0-4^{\circ}$ downward. The lengths of the blade control tension members (between the ends of the tips) should be between 305 and 320 mm.

After adjustment, one more test flight is made, with photography of the blades in the same flying regimes. The relative displacement of the ends of the blades should not exceed 1.5 mm on the film or 70 mm actual.

§8. Aerodynamic Characteristics of the Lifting Rotor

Aerodynamic Characteristics of Blade Profiles

Figure 20 shows the aerodynamic characteristics of the NACA-230M profile at various M numbers: Figure 20a shows the lift factor C_y as a function of angle of attack, while Figure 20b shows the polars of the NACA-230M profile at various M numbers. As we can see from the curves, the aerodynamic characteristics of the profile become considerably worse as we go down to the low M numbers at which the main portion of the blade operates.

Figure 21 shows the aerodynamic characteristics of profile TSAGI P-57-9 (high speed). Figure 21a shows the curves of the lift factor as a function of angle of attack for various M numbers (from 0.30 to 0.74), while Figure 21b shows the polars of the same profile for the same M numbers. Here the drag coefficient is taken only for the profile resistance without considering inductive drag. As we can see from the curves, the M number is increased to the high values at which the tips of the blades operate, the aerodynamic characteristics of the profile become worse: C_y decreases and C_{xp} increases.

Polar of Lifting Rotor in Hovering Regime

In the aerodynamic calculation, the characteristic of the entire lifting rotor in the hovering regime is represented in the form of a polar. The polar of the lifting rotor is a curve showing the thrust factor T_y and torque factor M_t as functions of the pitch of the lifting rotor ϕ . Coefficient T_y is similar to the lift factor of the wing C_y , while coefficient M_t is similar to the drag factor of the wing C_x . The polar of the lifting rotor in the hovering mode for the Mi-6 helicopter is shown on Figure 22. We can see from this figure: the higher the pitch of the lifting rotor, the greater the torque factor. Consequently, the greater the torque of the lifting rotor, the higher the thrust factor and the thrust of the lifting rotor in the hovering regime.

Thrust of Lifting Rotor in Hovering Regime

The thrust of the lifting rotor in the hovering regime is determined in the general case by the formula presented by N. Ye. Zhukovskiy.

$$T = (33,25 \eta_0 \sqrt{\Delta} DN_e)^{2/3}$$

33.25 η_0 is the Willner coefficient;

$\Delta = \frac{\rho_H}{\rho_0}$ is the relative density of the air;

ϵ is the power utilization factor;

D is the diameter of the rotor;

N_e is the power of the engine.

We can see from the formula that the thrust of the lifting rotor does not change in proportion to the power, but more slowly--to the 2/3 power.

For the Mi-6 helicopter, the thrust of the lifting rotor in the hovering mode was determined according to the polar using the following formula:

$$T = 0,5 \rho F_{om} \sigma (\omega R)^2 t_y$$

where F_{om} is the area swept by the lifting rotor;

σ is the filling factor of the lifting rotor;

ωR is the linear speed of the tip of the blades;

t_y is the thrust factor. With increasing altitude, the thrust

developed by the rotor in hovering decreases, as we can see from both formulas.

Maximum thrust developed by the rotor of the Mi-6 helicopter with trapezoidal blades in the hovering mode is shown as produced by calculation as a function of altitude on Figure 23. Here the thrust is given for two engine operating regimes: the liftoff and combat regimes, without considering the influence of the earth and with consideration of the influence of the nearness of the earth (air cushion). As we can see from the curves, at sea level altitude in the liftoff regime, without considering the influence of the earth, the rotor develops a thrust of over 38,000 kg; with consideration of the influence of the air cushion, the thrust is 42,000 kg. In the combat regime of engine operation, the thrust is less both with and without consideration of the influence of the nearness of the earth. As the altitude of hovering increases, the thrust of the rotor decreases in all cases.

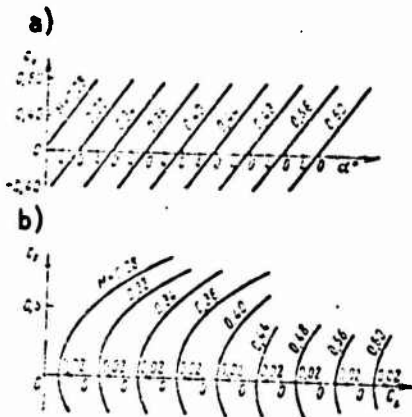

Figure 20. Aerodynamic Characteristics of NACA 230-M Profile: a, Lift factor as a function of angle of attack; b, Profile polars.

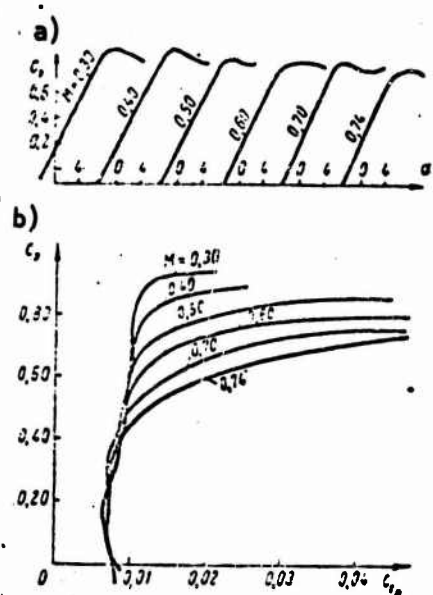

Figure 21. Aerodynamic Characteristics of TSAGI P-57-9 Profile: a, Lift factor as a function of angle of attack; b, Profile polars.

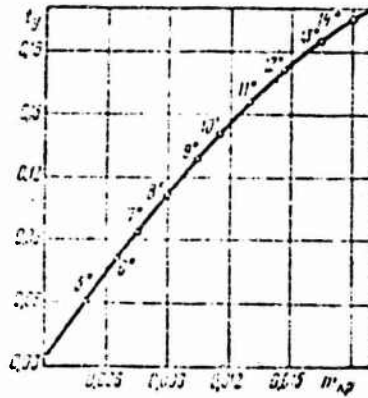

Figure 22. Polar of Mi-6 Lifting Rotor in Hovering Regime.

Figure 24 shows curves of the thrust developed by the rotors of the Mi-6 helicopter in three engine operating regimes: takeoff, combat and nominal, as a function of hovering altitude for a rotor with rectangular blades (solid curves) and trapezoidal blades (dotted curves), produced by flying tests and corrected to standard atmospheric conditions. From this figure we can see that the stronger the engine operating regime, the stronger the thrust of the rotor using trapezoidal or rectangular blades; furthermore, the lower the hovering altitude, the greater the thrust of both types of rotors, due to the influence of the air cushion effect. Outside the zone of influence of the air cushion ($H = 40$ m), the rotor with rectangular blades develops more thrust than the rotor with trapezoidal blades at all engine operating regimes. For example, the rotor with rectangular blades in takeoff regime develops a thrust of over 37,000 kg, in the combat regime--slightly less than 36,000 kg, and at the nominal regime about 34,000 kg, while the rotor with trapezoidal blades develops thrusts of 36,000, 34,500 and 32,000 kg at the same altitude, i.e., averaging 1,500 kg less. During forward flight, this difference is even greater. This is explained by the fact that the rotor with rectangular blades has better geometric and aerodynamic characteristics.

As we come closer to the earth, this difference begins to decrease due to the sharper increase in the thrust of the rotor with trapezoidal blades in comparison to the increase in the thrust of the rotor with rectangular blades. At a height of 12 m from wheels to surface or more precisely in the altitude range 10-15 m, this difference is zero, i.e., both rotors develop practically identical thrust in the same engine operating regime at this altitude. At this same altitude in the takeoff regime, both rotors develop a thrust of 40,000 kg, in the combat regime--38,500 kg and in the nominal regime 36,000 kg. At lower altitudes, the trapezoidal blade rotor develops greater thrust.

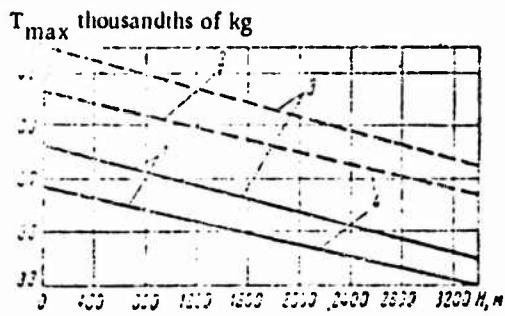

Figure 23. Maximum Thrust of Lifting Rotor of Mi-6 Helicopter as a Function of Altitude in Hovering Regime: 1, Without considering ground influence; 2, Considering ground influence; 3, Take-off regime; 4, Combat regime.

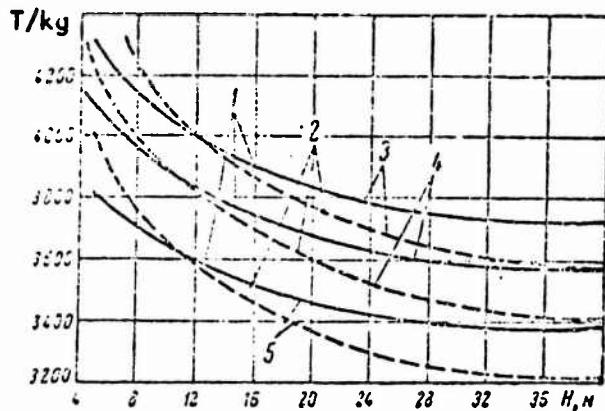

Figure 24. Thrust of Lifting Rotor as a Function of Engine Operating Regime and Hovering Altitude: 1, Rectangular blades; 2, Trapezoidal blades; 3, Takeoff regime; 4, Combat regime; 5, Nominal regime.

Thus, at an altitude of 5 m, the rectangular blade rotor develops a thrust at the power levels mentioned of 43,000, 41,000 and 38,000 kg, while the rotor with trapezoidal blades develops 1,700-2,000 kg more (see Figure 24).

This is explained by the fact that the rotor with rectangular blades has a greater "exposed" central area than the rotor with trapezoidal blades. For this reason, at altitudes below 15 m, the rotor with rectangular blades has poorer thrust characteristics than the rotor with trapezoidal blades.

At a hovering altitude of over 15 m and in forward flight, the rotor with rectangular blades has better thrust characteristics than the rotor with trapezoidal blades.

Consequently, when hovering near the surface of the earth, the thrust of the lifting rotor is greatly increased in all engine operating regimes, particularly for the trapezoidal blade rotor. For this rotor, the effect of the air cushion has a greater influence, since the central portion of the swept surface is better filled with the blades and therefore better conditions are created beneath the blade for maintenance of increased pressure.

Figure 25 shows the change in relative thrust T/T_{∞} of a lifting rotor with trapezoidal blades as a function of the relative hovering altitude H/D . We can see from the graph that the influence of the air cushion begins to appear at a relative height of 0.8, which is 28 m from the earth to the wheels of the helicopter chassis. As the helicopter moves closer to the earth, the effect of the air cushion increases and at a relative altitude of about 0.15, the relative thrust is 1.15, i.e., the thrust near the earth is 15% greater than the thrust of the same rotor developed outside the zone of influence of the earth (free thrust T_{∞}).

Flying tests have established that the change in the normal rotating speed of the engine turbine compressor when operated within the limits of the range established by the technical conditions for the take-off regime (93-95%) leads to a significant change in the thrust characteristics of the lifting rotor. For example, decreasing the rotation speed of the turbine compressor by 0.8% in hovering decreases the free thrust of the lifting rotor by 1,000 kg.

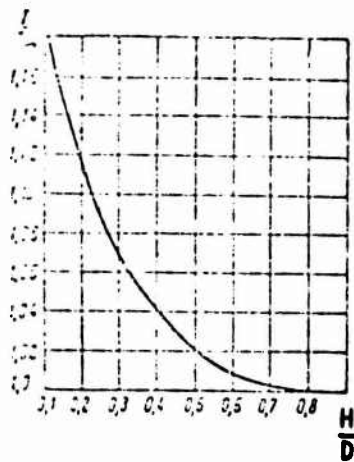

Figure 25. Characteristics of Lifting Rotor Mi-6 Helicopter in Hovering Regime in Zone of Influence of "Air Cushion."

1-

Flying tests have shown that the installation of rubber shielding on the blades to prevent abrasive wear has practically no influence on the thrust characteristics of the lifting rotor, and therefore leaves the flying and technical characteristics of the helicopter practically unchanged.

The influence of the wing on the thrust of the lifting rotor during hovering. As we know from the aerodynamics of a single rotor helicopter, the lifting rotor, located near the fuselage, creates less thrust than an isolated rotor would create due to the drag of the fuselage against the inductive flow directed downward. The thrust developed by the rotor will be decreased by the magnitude of this drag. In the Mi-6 helicopter, both the fuselage and the stub wings are located in the downward flow; therefore, the thrust of the rotor is decreased by an even greater quantity. Experiments performed at TSAGI have indicated that the "lifting rotor plus wing" system of the Mi-6 helicopter creates 2% less thrust than an isolated rotor in hovering. As the flight speed increases, the harmful influence of the wing on the lifting rotor decreases, so that in forward flight it need not be considered.

59. Aerodynamic Characteristics of Fuselage and Wing

Aerodynamic Characteristics of Fuselage and Keel Beam

Figure 26 shows the coefficient of lifting force of the fuselage c_{y_f} as a function of angle of attack. The angle of attack of the fuselage is read from its longitudinal datum line. As we can see from the graph, at zero angle of attack the lifting force factor is also equal to zero. This indicates that the fuselage has aerodynamic symmetry, although it is not geometrically symmetrical. With positive angles of attack the lift force factor, and therefore the lift, will be positive, while with negative angles of attack they will be negative. The lift of the fuselage is determined from the formula

$$Y_f = c_{y_f} \frac{\rho V^2}{2} S,$$

where S is the area of the wing, including the portion covered by the fuselage.

Figure 27 shows a polar diagram of the fuselage of the Mi-6 helicopter, which shows that it is expedient to fly with angles of attack near zero, at which the drag is minimal. In order to maintain the angle of attack near zero at cruising speeds, the shaft of the lifting rotor is set at an angle of 5° in the Mi-6 helicopter. The drag of the fuselage is determined from the formula

$$X_f = c_{x_f} \frac{\rho V^2}{2} S.$$

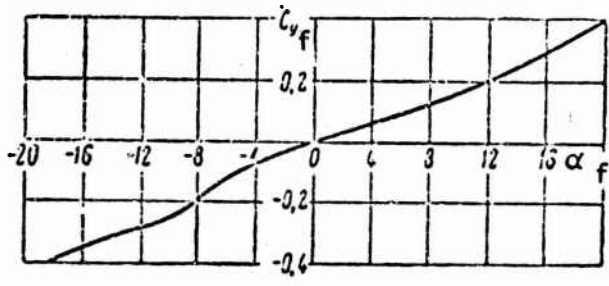

Figure 26. Lift Factor of Fuselage of Helicopter as the Function of Angle of Attack.

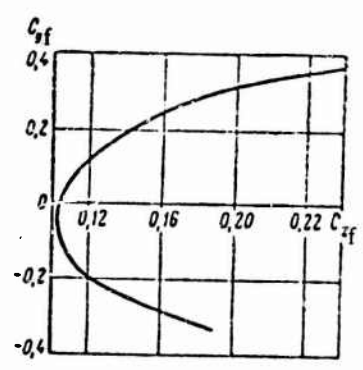

Figure 27. Polar Diagram of Mi-6 Helicopter Fuselage.

The tip beam, consisting of the keel beam, fixed rudder and removable faring, has a total area of 9.4 m². The fixed rudder has an asymmetrical shape due to the corresponding form of its ribs. As a result of this, during forward flight the rudder creates a lift directed in the direction of the thrust of the tail rotor during flight regimes with the engines operating--to the left, thus unloading the tail rotor. This unloading of the tail rotor is particularly necessary at near-maximum speeds, since at these speeds a great reactive torque is created by the lifting rotor, requiring high thrust of the tail rotor. The fixed rudder is most effective at these speeds.

In the autorotation mode, the fixed rudder will have a negative influence, since its lift will be directed opposite to the thrust of the tail rotor, requiring an increase in the negative pitch of the tail rotor.

However, this flying mode is rare, so this negative influence is of no practical significance.

Aerodynamic Characteristics of the Wing

Figure 28 shows the lift of the wing as a function of its angles of attack. We can see from the graph that with a zero angle of attack the lift is quite slight. This indicates that the profile of the wing is symmetrical. The curve also shows that at the critical angle of attack, equal to 20° , $C_{y\max}$ is over 1.1.

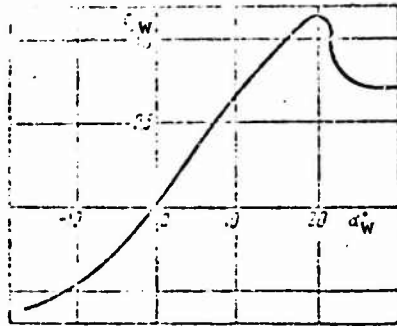

Figure 28. Lift Factor of Mi-6 Helicopter Wing as a Function of Angle of Attack.

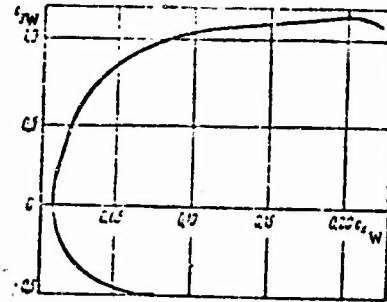

Figure 29. Polar Curve of Mi-6 helicopter Wing.

Figure 29 shows the polar curve of the Mi-6 helicopter wing.

The required wing angles of attack for any flying mode increase with increasing speed and altitude of the helicopter, since the higher the speed and altitude, the more necessary it is to unload the lifting rotor by increasing the lift of the wing (Figure 30).

The available (true) angles of attack of the wing in flying modes with engines operating change as follows with altitude and height. At low forward flight speeds, the angles of attack of the wing are slight, since a great inductive force from the lifting rotor acts on the wing, pressing the main airflow downward as it approaches the wing. For example, at 120 km/hr, the angle of attack of the wing is approximately 8° . With increasing flight speed, the pitch angle of the helicopter decreases, leading to a decrease in the angle of attack of the wing, but since the inductive flow from the lifting rotor decreases, at speeds up to 200 km/hr the angle of attack increases to $13-14^\circ$. Further increases in the flying speed cause the angle of attack of the wing to decrease as a result of the decreased pitch of the helicopter, in spite of the

increased angle of attack resulting from the decrease in inductive flow. A change in altitude causes the angle of attack of the wing at these same speeds to change slightly due to the changes in the inductive flow as a function of flying altitude. At flight speed up to 200 km/hr, the angle of attack decreases with increasing altitude, since the inductive flow from the lifting rotor increases. At speeds of over 200 km/hr, the angle of attack increases with increasing altitude.

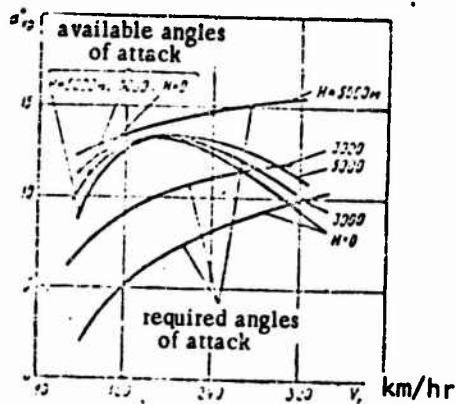

Figure 30. Required and Available Angles of Attack of Mi-6 Helicopter Wing in Flying Modes with Operating Engines.

In the autorotation (gliding) mode, the available (true) angle of attack of the wing changes as follows as a function of flight speed (Figure 31). At low speeds, the angle of attack is high, since the vertical descent speed is high. As the flight speed increases to the economical speed, the vertical descent speed decreases to the minimum, and therefore the angle of attack of the wing also decreases and becomes minimal.

With a further increase in speed, the angle of attack with the wing once more begins to increase due to the increased vertical descent speed.

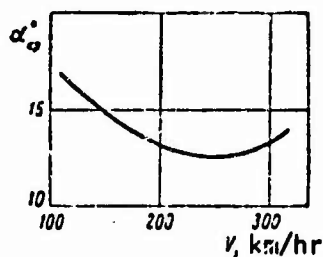

Figure 31. Available Angles of Attack of Wing in Autorotation Mode of Lifting Rotor.

The angle of attack of the wing in the autorotation mode is also influenced by the change in pitch angle as a function of flight speed; therefore, the minimum angle of attack will be at a speed higher than the economical speed.

Lift of wing. In the hovering mode and at low flight speeds, the wing creates a negative lift due to the influence of the inductive flow from the lifting rotor on the top of the wing. Thus, in the hovering mode, the lift is 2% of the total weight of the helicopter (thrust of the lifting rotor), i.e., about 800 kg. As the forward flight speed increases, the angle of attack of the wing increases, and when it becomes equal to zero at some forward speed, the lifting force is also equal to zero. Further increases in speed cause the lift of the wing to become positive, and at 200 km/hr it is 14% of the lift of the lifting rotor, at 250 km/hr it is 19% of the rotor lift and at 300 km/hr it is 25% of the rotor lift. Thus, at high flight speeds the wing creates considerable lift, significantly unloading the lifting rotor.

Aerodynamic Characteristics of "Fuselage + Wing" System

Figure 32 shows a curve which demonstrates the change in lift factor of the "fuselage + wing" system $c_{y f+w}$ as a function of its angle of attack α_{f+w} . As we can see from the graph, the lift factor of the system increases up to fuselage angles of attack of 5° , then decreases and, beginning at 9° angle of attack, increases once more, reaching the same value as that of the wing at the same angle of attack at 20° (see Figure 28). The lift factor $c_{y f+w}$ is zero only with a negative angle of attack of the fuselage of -8° .

Figure 33 shows a polar diagram of the "fuselage + wing" system.

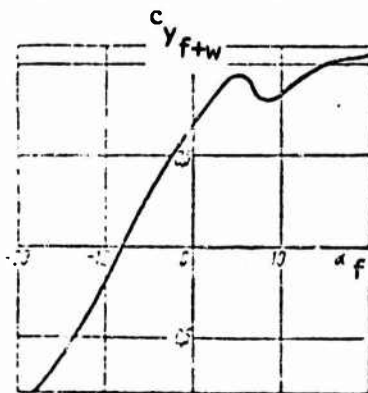

Figure 32. Lift Factor of "Fuselage + Wing" System as a Function of Fuselage Angle of Attack.

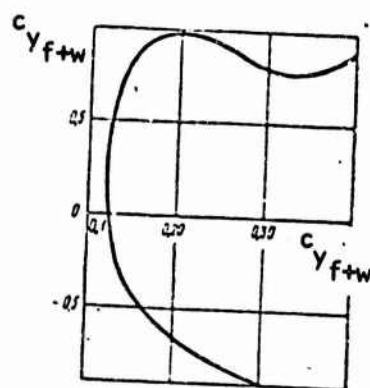

Figure 33. Polar Diagram of "Fuselage + Wing" System.

510. Tail Rotor Characteristics

The geometric parameters of the AV-63B tail rotors are as follows: 6.3 m diameter, blade width 0.5 m at $\bar{r} = 0.7$, blade profile NACA-230, relative thickness 0.096 at $\bar{r} = 0.9$, rotor filling factor 0.202. Weight of one blade 60 kg, of rotor 570 kg.

The kinematic characteristics of the tail rotor are the same as those of the lifting rotor. The blades have axial joints allowing the overall pitch of the rotor to be changed, and horizontal joints used to perform flapping movements relative to the plane of rotation. The blade can be deflected from the plane of rotation on the horizontal joint by 15° in either direction. The degree of reduction is such that the rotating speed of the tail rotor is decreased by 12.24 times in comparison to the rotating speed of the free turbine. The rotating speed of the tail rotor at the minimum permissible rotating speed of the free turbine (7800) is $7800:12.24 = 637$ rpm, at the maximum speed (8300)--678 rpm and at the maximum short-term (9000)--735.

The tail rotor, like the lifting rotor, forms a drag cone in forward flight which causes, with the aerodynamic force of the rotor, both longitudinal and lateral forces.

CHAPTER III. REQUIRED AND AVAILABLE HELICOPTER POWERS

§11. Required Power

The required power consumed by the Mi-6 helicopter, as is the case for any helicopter, is made up of inductive power, airfoil power and motor power. Furthermore, in the hovering mode and at low flight speeds, additional power is required to create additional rotor thrust due to the harmful influence of the wings. This additional power requires greater inductive and airfoil power, since creation of the additional thrust to balance the drag of the wing requires high inductive speed, leading to an increase in inductive drag of the blades. Furthermore, the airfoil resistance is increased due to the increase in the total lifting rotor or its rotating speed.

Influence of compressibility of air. In forward flight, beginning at moderate flight speeds, the Mi-6 blades have supercritical true speeds through the air in the 0-180° azimuth. At this point the compressibility of the air begins to have an influence on the characteristics, leading to the appearance of wave drag, which must be overcome by applying additional power, called the compression power. The higher the flight speed, the greater the wave drag, the greater the power required to overcome it. Consequently, the compression power increases with increasing flight speed.

The higher the flying altitude, the greater the compression power, since the compressibility of the air increases due to the decrease in the speed of sound. In the aerodynamic calculations for the Mi-6 helicopter, compressibility of air is considered by increasing the required torque factor

$$m = m_{\text{without com}} + \Delta m_{\text{com}}$$

The change in the increase of required torque Δm_{com} with horizontal flight speed and altitude is shown on Figure 34.

Consequently, the required power for forward flight of the Mi-6 helicopter will consist of the inductive, airfoil, motor and compression powers

$$N_{req} = N_{ind} + N_{af} + N_{mov} + N_{com}$$

The variation of these powers as a function of horizontal flight speed is shown in general form on Figure 35. As we can see from the figure, the inductive power is maximum at hovering, decreasing with increasing speed, since a greater mass of air moves through the lifting rotor per unit time. The airfoil power is minimum at hover and increases with increasing speed due to the increased airfoil losses. The movement power is equal to zero at hover, increasing with increasing speed due to the increased harmful drag. The compression power appears at moderate speeds, increasing with increasing speed. The summary required power for horizontal flight, as is the case for any helicopter, decreases up to the economical speed, then increases at speeds above the economical speed.

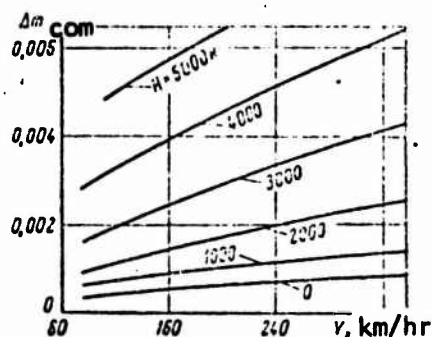

Figure 34. A Change in Required Torque Due to Compression with Flight Speed and Altitude.

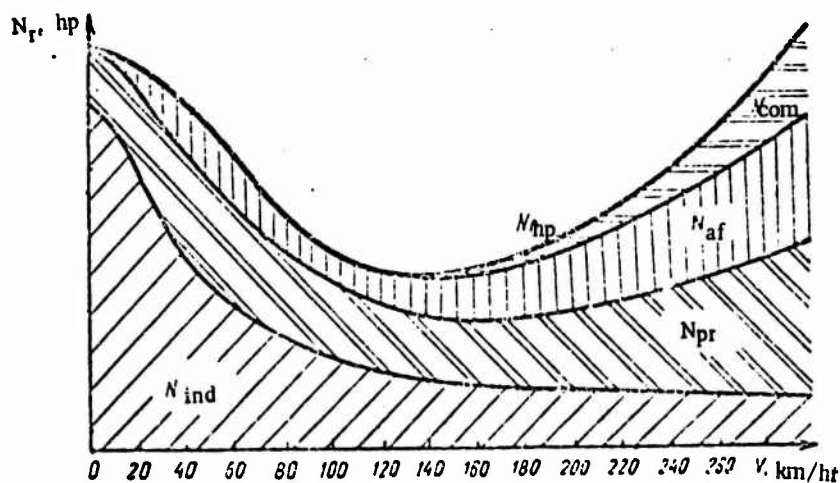

Figure 35. Change in Required Powers for Horizontal Flight of Mi-6 Helicopter as a Function of Speed.

The total required torque for flight of the helicopter is determined from the formula

$$M_t = m_t 0,5 \rho (\omega R)^2 F_{sw} R,$$

where F_{sw} is the area swept by the rotor cycle;

R is the radius of the rotor.

The required blade setting angles (total pitch of rotor) changes similarly to the change in required power as a function of horizontal flight speed: as the speed increases from zero to the economical speed, the required general pitch of the lifting rotor decreases, then as speed increases further, it increases (Figure 36).

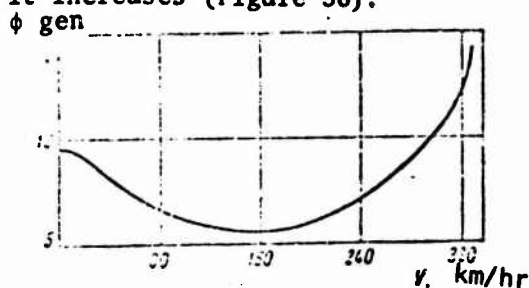

Figure 36. Required General Rotor Pitch for Horizontal Flight of Mi-6 Helicopter.

§12. Available Power

Characteristics of D-25V Engine

The choke characteristics of this engine are shown on Figure 37. The horizontal axis shows the relative numbers: ratio of rotating speed of turbine compressor in a given engine operating mode to rotating speed at the nominal mode $n_{tc}/n_{tc_{nom}}$; expressed in percentages. The vertical axis shows the relative powers N/N_{nom} , the relative specific fuel consumption $C_e/C_{e_{nom}}$ and the relative gas temperature T/T_{nom} , also expressed in percentages.

As we can see from the curves, with the choke valve open, the operating speed of the turbine compressor n_{tc} , power of the engine N and gas temperature T beyond the turbine increase, while the specific fuel consumption C_e decreases. The increase in effective power N_e with increasing rotating speed is explained by the simultaneous increase in air flow

through the engine and specific effective power (with increasing degree of increased pressure of the air π_k). The specific effective fuel consumption decreases continually with increasing rotating speed due to the increased degree of increase of pressure and temperature in the engine.

Operating regimes of D-25V engine. Table 1 shows the operating regimes of the D-25V engine, second series, beginning with serial No. C3532013 under standard atmospheric conditions near the earth and at 3,000 m altitude. Second series engines up to No. C3532013 have higher turbine compressor operating speeds, while first series engines have lower turbine compressor operating speeds.

The normal operating speed of the turbine compressor will refer to the rpm given for standard atmospheric conditions considering the regulation.

The "measured" rotating speed will refer to the rotating speed produced according to the indications of the instruments in flight at the temperature and altitude noted.

The D-25V engine is quite sensitive to changing temperatures of the surrounding air and flying altitude, since these changes lead to a change in the quantity of air passing through the engine and its power. In order to retain power within the required limits, the rotating speed of the turbine compressor must be altered. The higher the temperature of the surrounding medium and the higher the flying altitude, the higher must be the speed of the turbine compressor.

The maximum permissible "measured" turbine compressor speeds as a function of surrounding air temperature and flying altitude for second series engines from No. C3532013 up are shown in Table 2.

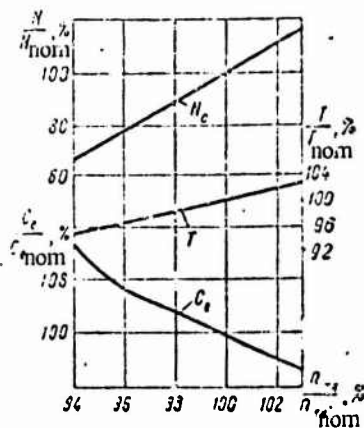

Figure 37. Choke Characteristics of D-25V Engine: N_2 , Power; T , Exhaust gas temperature beyond turbine; C_e , Specific fuel consumption.

TABLE 1. OPERATING REGIMES OF D-25V SERIES 2 ENGINES FROM NO. C3532013 UNDER STANDARD ATMOSPHERIC CONDITIONS

Engine Operating Mode	Indication on UPRT-2, Degrees	Rotating Speed of Compressor Rotor		Rotating Speed of Rotor Turbine rpm (measured)	Rotating Speed of Gas Temperature Beyond Turbine, °C	Continuous Operating Time, min
		ITE-2 (normal)	ITE-1 (measured)			
Takeoff	97 ± 3 (stop)	9030 ± 150 —100	93.5 ± 1.5 —1.0	7800—8300	78—83	6
Combat	93 ± 2	9850 ± 150 —100	92.5 ± 1.5 —1.0	7800—8300	78—83	15
Nominal	81 ± 2	9670 ± 150 —100	91 ± 1.5 —1.0	7800—8300	78—83	120
Cruising (0.85 nominal)	71 ± 2	9130 ± 150 —100	88.5 ± 1.5 —1.0	7800—8300	78—83	no restrictions
Cruising (0.66 nominal) Idle	55 ± 2	9080 ± 150 —100	85.5 ± 1.5 —1.0	7800—8300	78—83	Ditto
Parked idle		5500 ± 100 (measured)	51.5 ± 1	3100—4000	31—40	30

$H = 0, V = 0, P = 760 \text{ mm Hg. } \rho_{\text{air}} = 1.225 \text{ kg/m}^3$

Engine Operating Mode	Rotating Speed of Compressor Rotor		Rotating Speed of Rotor Turbine		Continuous Operating Time, min
	Indication on UPRT-2, Degrees	ITE-2 (normal) rpm	ITE-1 (measured) rpm	Gas Temperature Beyond Turbine, °C	

$H = 3000$ ft, $V = 0$, $P = 55.8$ mm Hg., $T_{air} = 4.5$ °C

Engine Operating Mode	Indication on UPRT-2, Degrees	ITE-2 (normal) rpm	ITE-1 (measured) rpm	Gas Temperature Beyond Turbine, °C	Continuous Operating Time, min
Takeoff	97±3 (stop)	10650 (max measured)	97.5 max	78-83	6
Combat	93±2	10450±150 —100	98±1.5 —1.0	76-83	15
Nominal	84±2	10250±150 —100	96±1.5 —1.0	76-83	120
Skip (0.85 nominal)	71±2	10000±150 —100	94±1.5 —1.0	78-83	no restriction
Skip (0.56 nominal)	55±2	9630±150 —100	90±1.5 —1.0	78-83	Ditto

TABLE 2. MAXIMUM PERMISSIBLE COMPRESSOR OPERATING SPEED AS A FUNCTION OF AIR TEMPERATURE AND FLIGHT ALTITUDE IN PERCENT

H, m	Air Temperature in °C									
	-50 -60	-40 -50	-30 -40	-20 -30	-10 -20	0 -10	10 20	11-20	21-30	31-40
0	85,5	86,5	88,0	89,5	90,5	92,0	93,5	91,5	96,0	97,5
500	86,5	88,0	89,5	91,0	92,5	93,5	95,0	96,5	98,0	—
1000	88,0	89,5	90,5	92,0	93,5	95,0	96,0	97,5	98,5	—
1500	89,0	90,5	92,0	93,5	95,0	96,0	97,5	98,5	—	—
2000	90,5	92,0	93,0	94,5	96,0	97,5	99,0	—	—	—
2500	91,5	93,0	94,5	96,0	97,5	99,0	—	—	—	—
3000	92,5	94,0	95,5	97,0	98,5	99,5	—	—	—	—
3500	93,5	95,0	96,5	98,0	99,5	—	—	—	—	—
4000	91,5	96,0	97,5	99,5	—	—	—	—	—	—
and more										

NOT REPRODUCIBLE

Table 2 shows the rotating speed of the turbine compressor in percentages according to the ITE-2.

The maximum permissible gas temperature beyond the turbine for second series engines as a function of surrounding air temperature and "measured" rotating speed of turbine compressor is shown in Table 3.

TABLE 3. MAXIMUM PERMISSIBLE GAS TEMPERATURE BEYOND TURBINE FOR D-25V ENGINE, SECOND SERIES

Rotating speed of turbine according to ITE-2, %	Gas temperature beyond turbine at surrounding air temperature, °C			
	-50-21	-20-0	0-20	21-40
Up to 85	470	475	510	560
85-90	490	510	510	595
90-95	570	580	590	630
95-99	650	650	650	650

The exhaust gas temperature is measured by 2TVGZ-1 devices installed on the instrument panels of the pilots and flight engineer.

The power of the D-25V engine in takeoff regime near the earth is $5500 \times 2 = 11,000$ Hp on the free turbine shaft. The takeoff mode of the engines is used for takeoff and landing of the helicopter, for vertical

flight movements, particularly under difficult climbing conditions, and also when flying with one engine. In the takeoff mode of engine operation, the general lifting rotor pitch is approximately 9° with the gas corrector fully to the right, if the helicopter is tied down or in the hovering mode. If the helicopter is moving forward, the general pitch of the lifting rotor will be greater than 9° , since the lifting rotor is lightened by the speed and must be made heavier to maintain the required rotating speed, using the general pitch lever.

In the combat engine operating mode, the power near the earth is $5200 \times 2 = 10,400$ Hp. The combat mode is used under the same conditions as the takeoff mode.

At the nominal operating mode of the engine, the power on the free turbine shaft near the earth is $4700 \times 2 = 9400$ Hp. The nominal operating mode is used principally for climbing.

At the first cruising operating mode (0.85 nominal), the power on the shaft of the free turbine at the earth is $4000 \times 2 = 8,000$ Hp. This mode is used for climbing and horizontal flight of the helicopter.

In the second cruising mode (0.66 nominal), used principally for horizontal flight at cruising speeds, the engines develop a power of $3100 \times 2 = 6,200$ Hp on the shaft of the free turbine at ground level under standard atmospheric conditions.

These engine operating modes can be produced at ground level using the "pitch-gas" lever with right correction: the greater the pitch, the higher the operating mode of the engine. In forward flight, these engine operating modes are set with the proper pitch and position of the gas corrector as a function of the flying mode, speed, flying weight of the helicopter, altitude and atmospheric conditions.

Altitude characteristics of B-25V engine. The D-25V engine is a high altitude gas turbine engine. At all operational modes, under international standard atmospheric conditions, its power up to its design altitude (altitude limitation) either increases or remains unchanged in comparison with its altitude at ground level, then decreases after reaching the design altitude.

Figure 38 shows the altitude characteristics of the D-25V engine in relative coordinates. The level of 100% represents the power, specific fuel consumption, turbine compressor rotating speed and gas temperature at the nominal operating mode of the engine.

In any gas turbine engine, the power depends on temperature and pressure. As atmospheric pressure increases, the power increases due to the increased flow of air through the engine per unit time, while as pressure decreases the power decreases. With increasing air temperature, the engine power decreases, since the quantity of air passing through the engine per unit time decreases.

NOT REPRODUCIBLE

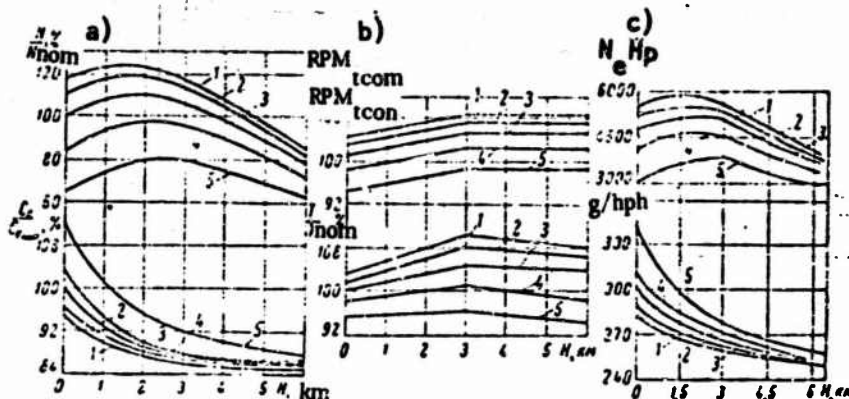

Figure 38. Altitude Characteristics of D-25V Engine: a, Change in power and specific fuel consumption with changing flight altitude; b, Change in rotating speed of turbine compressor and gas temperature with changing flight altitude; c, Change in power and specific fuel consumption with changing flight altitude in absolute numbers: 1, Takeoff mode; 2, Combat mode; 3, Nominal mode; 4, 0.85 nominal; 5, 0.66 nominal.

With increasing altitude, the air temperature and pressure decrease. The decrease in temperature causes an increase in power, while the decrease in pressure causes a decrease. The degree of influence of air pressure on power is greater than the influence of temperature, so that the engine power decreases with increasing altitude overall. Consequently, a gas turbine engine is a low altitude engine.

The high altitude capacity of the D-25V engine is achieved by the fact that the gas temperature before the turbine of the engine at ground level is low in comparison to the maximum possible temperature determined by the strength characteristic of the engine parts. The power of the engine is proportional to the temperature of the gases before the turbine: the more fuel fed to the engine, the higher the gas temperature after combustion, the higher the gas flow rate and the higher the torque on the free turbine. In order to retain power up to the design ceiling the gas temperature before the turbine must be increased.

The increase in gas temperature and turbine speed to the design altitude is automatic, performed by the programming device of the NR-23A pump-regulator. As altitude increases, the aneroid of the altitude-speed adjustment mechanism expands and a tracking system and centrifugal pick-up adjust the rotating speed regulator to higher compressor speed by increasing the fuel flow to the engine. The operation of the program device continues up to 3000 m altitude under standard atmospheric conditions. Upon reaching this altitude, fuel supply to the engine becomes maximum,

the gas temperature before the turbine and the rotating speed of the turbine compressor reach the maximum permissible level according to the strengths of the rotating parts of the engine in the takeoff mode and engine power reaches its maximum value (see Figure 38).

With further increases in altitude, the fuel supply decreases. The gas temperature before the turbine decreases as a result of the decreasing external air temperature. The rotating speed of the turbine compressor remains constant due to the proportional decrease in torque from the gases and in the required torque resulting from the decrease in air density. The engine power decreases.

As we can see from Figure 38, the power in the takeoff regime up to the design altitude of 3000 m does not remain strictly constant: it first increases, then decreases, but is the same at 3000 m as at the ground level. In other engine operating modes the power at 3000 m is higher than at ground level.

At the fixed engine operating mode (for the D-25V up to 8800 rpm) the fuel consumption rate remains constant before the beginning of automatic operation, but the turbine compressor rotating speed will change as a function of pressure and temperature: the higher the pressure and lower the temperature, the less the rotating speed of the temperature. At 8800 rpm, the speed is automatically adjusted as a function not only of pressure, but also of air temperature according to a program providing for constant engine power not only up to the design altitude under standard atmospheric conditions, but within the temperature range from -40°C to $+40^{\circ}\text{C}$ at standard atmospheric conditions.

This automatic operation of the fuel system allows the required motor power to be maintained for almost all temperatures for any time of year, latitude and altitude, allowing the helicopter to be operated successfully.

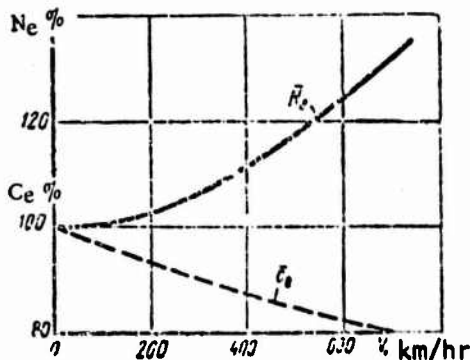

Figure 39. Change in Power and Specific Fuel Consumption of Turbo-Prop Engine as Functions of Flying Speed.

Altitude-speed characteristics. Let us analyze the influence of flight speed on the effective power of the turboprop engine in the general case. All remaining factors influencing engine power will be considered constant: flying altitude, rotating speed of engine, atmospheric conditions. As the speed increases, the power of the engine will increase as a result of the fact that the air flow rate and general compression ratio π_k increase due to the velocity head of the oncoming air stream. The increase in preliminary velocity compression causes an increase in air temperature, so that the compression ratio of the compressor decreases. However, since the compressor is compressing air which has been preliminarily compressed by the effect of the velocity head, the overall compression ratio increases. Therefore, the density and therefore the quantity of air passing through the engine is increased, i.e., the power is increased and the specific fuel consumption is decreased (Figure 39). During flight, velocity and altitude change, leading to a change in engine power resulting from these two factors simultaneously.

Figure 40 shows the altitude-velocity characteristics of the D-25V engine. Here the power up to design altitude in all operating modes is arbitrarily shown by straight lines. The solid lines show the change in power of the engine with altitude at all indicated modes during hovering ($\mu = 0$), while the dotted lines show the change in power with altitude during forward flight ($\mu = 0.22$, $V = 180$ km/hr). We can see from these curves that the increase in power due to the velocity head is about 200 Hp and remains almost constant at all operating modes of the engine at all altitudes. The higher the flying speed, the higher the altitude to which the power is retained or even increased, i.e., the higher the flight speed, the greater the design altitude of the engine. In the example at hand for $\mu = 0.22$, it is 3500 m.

Engine Power Losses and Power Utilization Factor

Power losses. Losses of effective engine power in the Mi-6 helicopter consist of losses to intake, friction, cooling, losses in the drive and tail rotor losses.

The power losses of the engine to intake arise due to the placement of the engine on the fuselage and the resistance in the air intake tunnel. These losses amount to 2.5% of the effective power of the engine. Power losses to friction in transmission amount to 3% of the effective power. Power losses to cooling, i.e., rotation of the fan for cooling of the fan amount to 1.15%, losses in the drive system for the helicopter units amount to 0.8% of the effective power of the engine. All of these losses remain unchanged with changing flight speed.

NOT REPRODUCIBLE

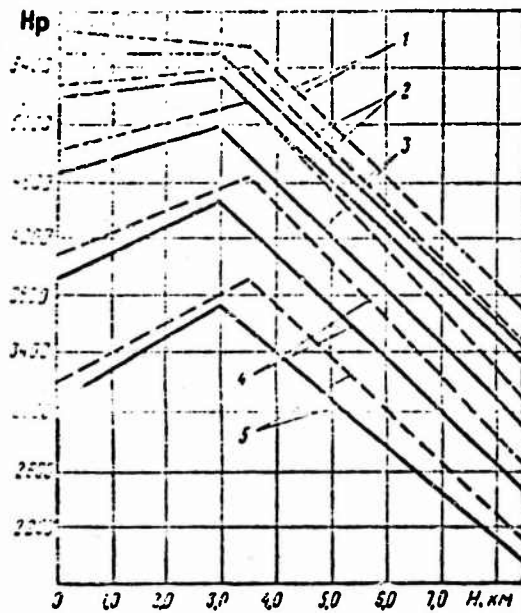

Figure 40. Altitude-Velocity Characteristics of D-25V
 Engine: 1, Takeoff mode; 2, Combat mode; 3, Nominal mode;
 4, 0.85 nominal mode; 5, 0.66 nominal mode.

The losses of engine power involved in driving the tail rotor change as a function of flight speed: during hovering, they amount to 9% of the effective power, with increasing speed they decrease and at $\mu = 0.3$ ($V = 240$ km/hr) they amount to 3.5%, then they increase again with further increases in flight speed and at the maximum speed (300-320 km/hr) they amount to 5% (Figure 41). The decrease in power losses involved in driving the tail rotor with increasing speeds are explained by the decrease in power consumption for flight of the helicopter, as well as the improved operating conditions of the tail rudder itself in a slanted airflow up to 240 km/hr. This is also explained by the fact that with increasing flight speed, the pilot has to press the left pedal forward in order to retain the same flight direction, decreasing the pitch of the tail rotor.

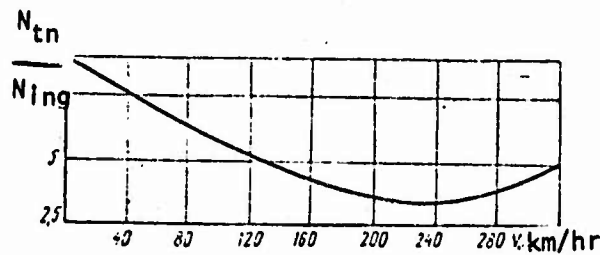

Figure 41. Engine Power Losses in the Tail Rotor.

At over 240-250 km/hr, the pitch of the tail rotor must be increased by moving the right pedal forward¹.

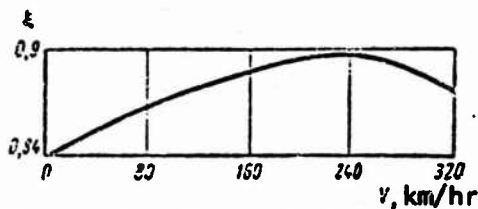

Figure 42. Change in Power Usage Factor of Mi-6 Helicopter with Flight Speed.

Power usage factor. All of the power losses mentioned above are taken into consideration by using the power usage factor ξ , which shows the fraction of the engine power which is transmitted to the lifting rotor hub. It is determined by the ratio of available power of the lifting rotor to the effective engine power

$$\xi = \frac{N_{P_{lr}}}{N_e}$$

The change in power usage factor as a function of flight speed for the Mi-6 helicopter is shown on Figure 42. We can see from this figure that when hovering the usage factor is 0.8355, with increasing speed it increases due to the decrease in engine power losses to operate the tail rotor and at 240 km/hr it reaches its maximum value of 0.89.

Further increases in speed cause the factor to decrease, since the losses of power to operate the tail rotor increase.

Available Lifting Rotor Power

The available power at the lifting rotor refers to that portion of the effective engine power extended to rotate the lifting rotor. This power is defined as the difference between the effective power of the engine and the losses to intake, friction and cooling, in the drive mechanisms and tail rotor.

$$N_{P_{lr}} = N_e - (N_{in} + N_{fr} + N_{cool} + N_{dr} + N_{tr}).$$

¹We show here calculated data; flying data will be presented in Chapter IX, "Balancing."

Since these losses are independent of velocity with the exception of losses in the tail rotor, the nature of the change in available power with changing flight speed is similar to the change in power usage factor.

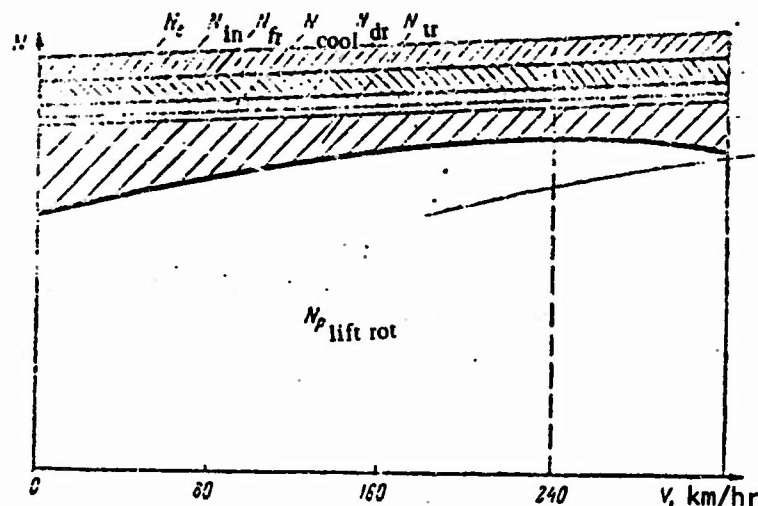

Figure 43. Change in Available Power of Lifting Rotor as a Function of Flight Speed.

On Figure 43, the change in available power of the lifting rotor for the Mi-6 helicopter will appear as follows in general form. The effective engine power increases with increasing flight speed, since the compression ratio π_k increases. The power losses of the engine to intake, friction, cooling and in the drive do not change with changing flight speed, while the tail rotor losses decrease up to 240 km/hr, then increase. Therefore, the available power at the lifting rotor will increase with increasing flight speed from 0 to 240 km/hr both due to the increase in speed and due to the decrease in tail rotor losses. After that, the available power will decrease with increasing speed, although the effective power continues to increase, since the losses in the tail rotor will be greater than the increase in power resulting from increased flight speed.

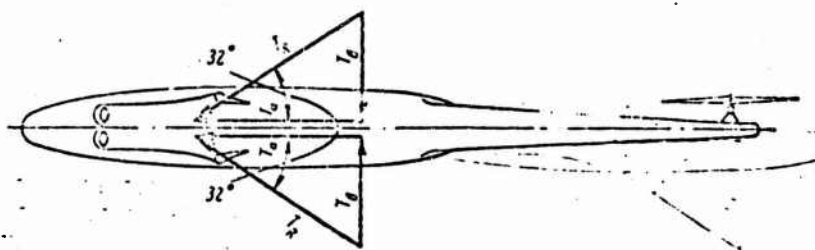

Figure 44. Reactive thrust of engine

Reaction thrust of engines. In the D-25V engine, the pressure of the exhaust gases is greater than atmospheric pressure. Therefore, the exhaust gases have energy and create a reaction thrust directed opposite to the direction of movement of the exhaust gases. The exhaust tubes are located at an angle of 32° to the longitudinal axis of the helicopter (Figure 44). The reactive force of the exhaust gases T_R can be broken down into components T_a and T_b . Component T_b of the two engines is directed at 90° to the longitudinal axis of the helicopter and balances, while component T_a is directed in the direction of the flight and supplements the horizontal component of the lifting rotor thrust. The less the angle between the longitudinal axis of the helicopter and the axis of the exhaust tubes, the greater the component T_a of the reaction thrust, the greater the increase in flight speed. Due to the placement of the engines, this angle cannot be reduced.

The reaction thrust of the engines depends on the flight speed: the higher the speed, the greater the reaction thrust.

In aerodynamic calculations, one usually considers the reaction thrust of the engine as an increase in available lifting rotor power, and considers the increase in available torque using its own coefficient Δm_{t_R} . Then the available lifting rotor power, considering the reaction thrust of the engine, will change with changing flight speed as shown on Figure 45.

The increase in torque coefficient resulting from the reaction thrust of the engine is determined from the formula

$$\Delta m_{t_R} = \frac{t_{x_R} \mu \cos \chi}{\eta_{mov}}$$

where t_{x_R} is the rotor thrust factor resulting from exhaust gas reaction;

χ is the angle between the longitudinal axis of the helicopter and the axis of the engine exhaust tubes;

η_{mov} is the efficiency of the lifting rotor as a propeller.

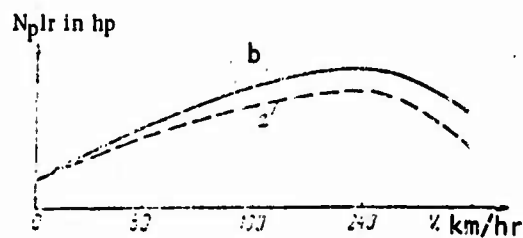

Figure 45. Available Lifting Rotor Power of Mi-6 Helicopter as a Function of Flight Speed in General Form: a, Without considering reaction thrust of engines; b, Considering reaction thrust of engines.

Assuming η_{mov} to be constant, equal to 0.9, and $\chi = 32^\circ$, for the Mi-6 helicopter the formula of the increase in torque factor due to reaction thrust becomes

$$\Delta m_{tR} = 0.95 t_{xR} \mu.$$

This formula can be used to construct a graph of the dependence of torque factor increase due to reaction thrust of the engine on the mode characteristic μ and flight altitude (Figure 46). We can see from the graph that the greater μ and the greater flying altitude, the greater the increase in the factor.

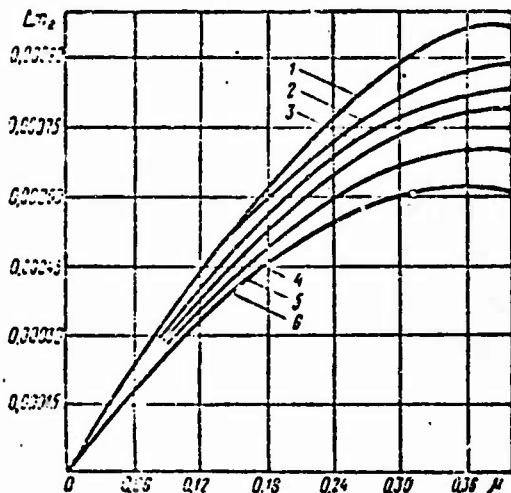

Figure 46. Change in Increase in Torque Factor Due to Reaction Thrust of Engines as a Function of μ and Flying Altitude of Mi-6 Helicopter:

- 1 - H-100, $\mu = 0.36$, $v_R = 225$ m/sec
- 2 - H-100, $\mu = 0.30$, $v_R = 225$ m/sec
- 3 - H-100, $\mu = 0.24$, $v_R = 225$ m/sec
- 4 - H-100, $\mu = 0.18$, $v_R = 225$ m/sec
- 5 - H-100, $\mu = 0.12$, $v_R = 225$ m/sec
- 6 - H-100, $\mu = 0.06$, $v_R = 225$ m/sec

NOT REPRODUCIBLE

The total (summary) available torque factor $m_{t\epsilon}$ will consist of the available torque factor for rotation of the lifting rotor and the torque factor resulting from engine reaction thrust

$$m_{t\epsilon} = m_{t\text{avail}} + \Delta m_{tR}.$$

§13. Balance of Powers

Figure 47 shows the balance of powers for the Mi-6 helicopter in general form. This figure shows how the powers change with flight speed with a given operating mode of the engines. The ordinate shows the effective engine power for a given operating mode, for example the takeoff mode. The abscissa shows the true flight speed of the helicopter. With increasing flight speed, the effective power of the engines increases due to the increased air pressure head, so that this power is shown by a straight, ascending line. The area of the trapezoid a, b, c, d is arbitrarily taken as the effective engine power in the takeoff mode. This

power is distributed to intake, rotation of the entire transmission, the fan, drive units, rudder and lifting rotors (available power of lifting rotor). Along the top on the ordinate we show successively the power consumed for intake, friction, cooling, unit drive and to the tail rotor. Then the available lifting rotor power, without considering reaction thrust to the engines, is illustrated by the dotted line. Considering the reaction thrust of the engines, this power is illustrated by the solid line. As we can see, the available power of the lifting rotor first increases, then decreases with increasing flight speed.

NOT REPRODUCIBLE

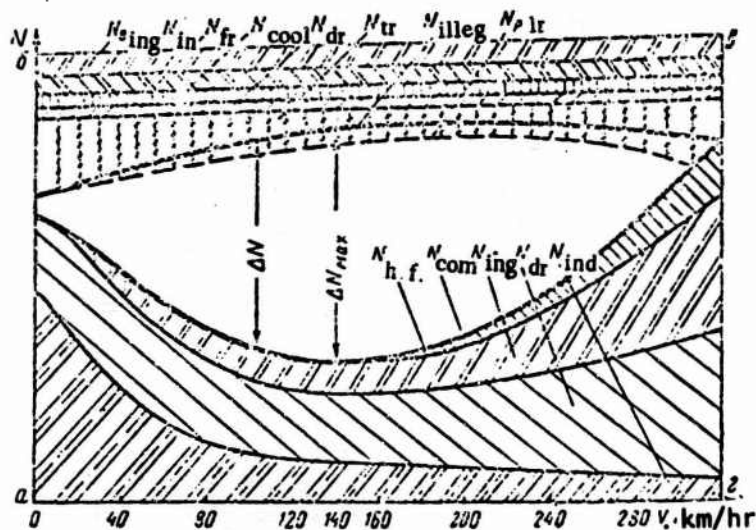

Figure 47. Balance of Powers of Mi-6 Helicopter in General Form.

This same graph also shows all required powers for horizontal flight of the helicopter: inductive, airfoil, movement and compression. The sum of all required powers must fall within the area of available power in order to support horizontal flight throughout the entire range of speed. Furthermore, it is desirable that there be excess power available for flight in other regimes. The sum of all required powers decreases as speed is increased to the economical speed (140 km/hr for the Mi-6 helicopter). With a further increase in speed, the required power increases. The excess of power, as we can see from the graph, is maximum of the economical flight speed.

In the aerodynamic calculations for the Mi-6 helicopter, available and required powers as functions of flight speed at various altitudes are represented in the form of changes in available and required torque, expressed through the dependence of the torque factors m_t on characteristics of flight regime μ and altitude (Figure 48). Here we see the torque factors

for the takeoff and nominal modes. Calculation of these factors for $\mu = 0.25$ was performed without considering the increase in these factors resulting from flight speed, i.e., calculation was performed for the hovering mode ($\mu = 0$). Beginning at $\mu = 0.3$ to 0.4 , these coefficients are represented for a given helicopter flight speed corresponding to $\mu = 0.22$; the curves corresponding to the values from $\mu = 0.25$ to 0.3 are connected by dotted lines.

NOT REPRODUCIBLE

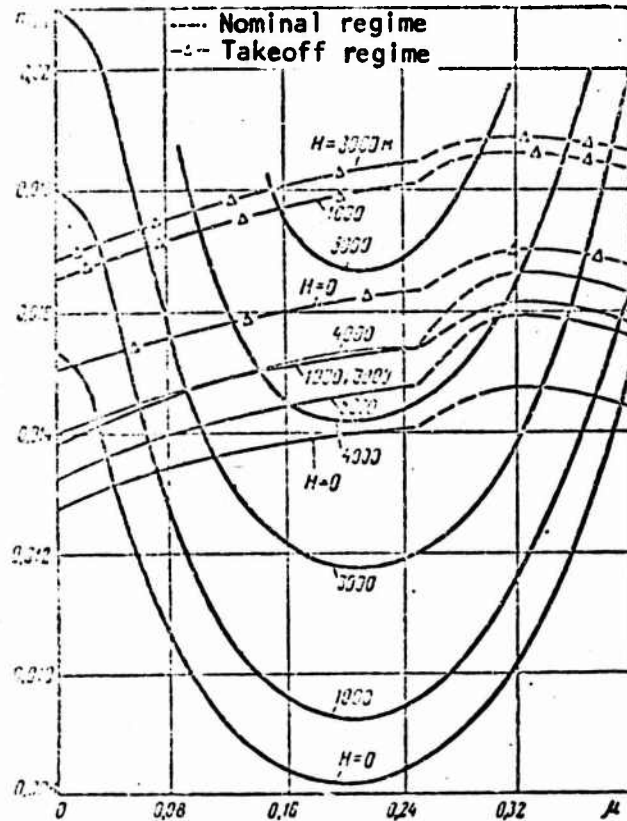

Figure 48. Available and Required Torque Factors as Functions of Regime Characteristics and Flying Altitude at Takeoff and Nominal Regimes.

§14. Control of Engine and Rotor Using the "Pitch-Gas" System

There are two systems for maintaining a constant rotating speed of the helicopter lifting rotor: the pitch-gas system and the automatic system. For the Mi-6 helicopter, the pitch-gas system was selected.

The operating principle of the pitch-gas system is that there is a mechanical, programmed connection between the automatic pitch changing mechanism and the engine fuel lever (system of tension members and rockers), so that when the pitch lever is moved, the pitch of the rotor and the operating mode of the engines are both changed simultaneously so that the rotating speed of the rotor remains constant (Figure 49). However, this mechanical coupling can retain the rotating speed constant only at certain temperatures and pressures of the surrounding medium, flying weight of the helicopter, flying mode and altitude and with certain other factors constant. When these conditions change, a change in the position of the lever 1 leads to a change in the rotating speed of the lifting rotor. In this case, the gas corrector knob must be rotated in order to maintain the required lifting rotor speed. The correction feeds signal b to the system, changing the operating mode of the engine, bypassing the mechanical connection to the rotor pitch mechanism 3. This causes the turbine compressor speed regulator 4 to change the rate of fuel supply to the engine through coupling f, and the rotating speed of the lifting rotor changes as required, i.e., the pilot retains the speed constant at the level necessary for the flying mode being used.

In order to change the operating mode of the engines, the pilot moves pitch lever 1, which acts through the programmed coupling mechanism 3 to change simultaneously the rotor pitch through coupling a and the engine power through coupling b. This causes the automatic regulator acceptability device (fuel pressure rise limiter) to operate, feeding a new portion of fuel through coupling g and further through coupling f to the combustion chamber. This moves the engines to a new operating mode, while the available power and required power for rotation of the lifting rotor balance. If the rotating speed deviates from the required speed, the pilot adjusts it as required.

In a stable engine operating mode, the rotating speed of the turbine compressor is maintained constant using the rotating speed regulator. If the rotating speed of the turbine compressor changes for any reason, signal e is sent to change the fuel supply and the rotating speed will be maintained constant. This same signal also limits the maximum rotating speed of the turbine compressor.

Signals d and c, depending on temperature and pressure of the air or flying altitude, change the rotating speed of the turbine compressor by changing fuel input, i.e., retain the fixed engine power level as required.

The pitch-gas system of the Mi-6 helicopter has no cam mechanism as in other helicopters, simplifying its design and decreasing friction in the system; it consists of a set of tension members and rockers.

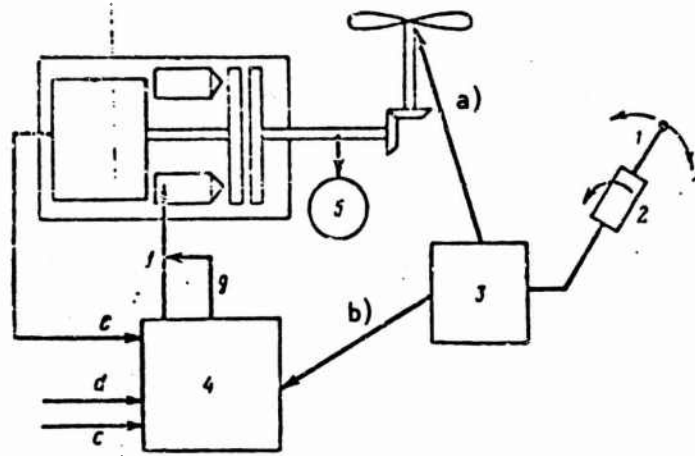

Figure 49. Diagram of Pitch-Gas System for Helicopter with Gas Turbine Engine: 1, "Pitch-Gas" lever; 2, Turbine compressor operating mode corrector; 3, Mechanism coupling operating modes of engine and rotor; 4, Rotating speed regulator for turbine compressor; 5, Free turbine rpm indicator: a, Signal to change rotor pitch; b, Signal to change engine operating mode; c, Signal indicating pressure of surrounding medium; d, Signal indicating temperature of surrounding medium; e, Signal indicating rotating speed of turbine compressor; f, Fuel supply to engine; g, Fuel pressure rise limiter.

However, control of the lifting rotor and engines using the pitch-gas system is rather complex. The rotating speed of the lifting rotor often varies above or below the permissible levels. The pilot must operate the gas corrector at almost all flying modes. Furthermore, during descent with engines operating with the corrector removed, operating at the permissible rotating speed of the lifting rotor, it was impossible to achieve the desired vertical descent rate: it was below the recommended rate; it was difficult to perform a landing, particularly with the helicopter unloaded. Therefore, the pitch-gas system has been modified several times.

As a result of the improvements performed, after proper adjustment, which is performed following elimination of variations in lifting rotor blade track, the characteristic of the pitch-gas system should be as shown below (Table 4 and Figure 50).

With the general pitch lever in the lower position, the general pitch of the lifting rotor is 1° according to the indicator, and if the gas corrector is moved to the left to stop, this corresponds to the middle position of the gas corrector. This is achieved by adjusting the device so that with a pitch of 1° and medium correction, the rockers at rib No. 1

are against their upper stops. The indications of the UPRT-2 (fuel lever position indicator) should be 15-18° (point a). If the engine is operating in this case, the rotating speed of the lifting rotor (rotor turbine) should be 34-40%. Consequently, point a on the graph corresponds to the idle mode of the engines.

TABLE 4. CHARACTERISTICS OF PITCH-GAS SYSTEM

Pitch from Indicator, deg	Trapezoidal blades			Rectangular blades		
	Left correction	Right correction		Left correction	Right correction	
	Reading of UPRT-2, deg	Turbine rpm, %	UPRT-2 reading, deg	Reading of UPRT-2, deg	Turbine rpm, %	UPRT-2 reading, deg
1	15-18	76-80	32-36	15-18	78-82	30-36
5	—	81-83,5	60-68	—	84-87	60-68
8	21-28	81-86,5	81-92	21-28	81-87	84-92
9 ± 30'	—	85-86,5	97-100	—	83-86	97-100

NOT REPRODUCIBLE

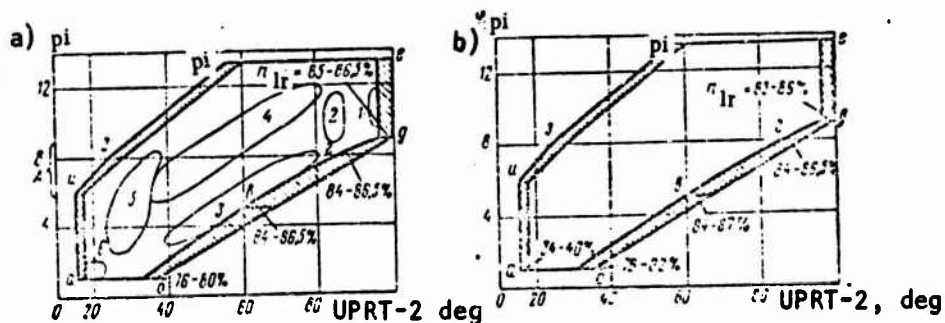

Figure 50. Characteristics of Pitch-Gas System: a, Trapezoidal blades; b, Rectangular blades; A, Range of overall rotor pitch corresponding to complete travel of gas correction 101°: 1, Climbing in takeoff regime; 2, Climbing in nominal regime; 3, Horizontal flight at $n_{lr} = 8700$ rpm; 4, Horizontal flight at $n_{lr} = 7800$ rpm; 5, Descent with engines operating at $V_y = 4-5$ m/sec; 6, Gliding in autorotation mode of lifting rotor.

If the gas corrector lever is now moved, without touching the pitch lever, to its right stop, the indications of the UPRT-2 should be 32-36°, and the rotating speed of the rotor should be 76-80% for a trapezoidal

blade rotor, and correspondingly 30-36° and 78-82% for a rectangular blade rotor (point b on Figure 50).

As the pitch is increased with the corrector to the right, the indications of the UPRT-2 will increase, and the rotating speed of the lifting rotor will increase as well. With a pitch of 5°, the indications of the UPRT-2 should reach 60-68%, and the rotating speed of the lifting rotor with trapezoidal blades should reach 84-86.5%, or 84-87% with rectangular blades (point c). Further increase in the pitch should cause the UPRT-2 indications to increase, while the rotating speed of the lifting rotor remains constant, so that at 8° pitch the UPRT-2 should read 84-92% and the rotating speed should be the same as at pitch 5° (point d). With a pitch of 9°, the indications of the UPRT-2 should read 97-100%, but the rotating speed of the lifting rotor with trapezoidal blades should be 85-86.5%, or 83-86% for a rectangular blade rotor (point e, takeoff regime).

These rotating speeds of the lifting rotor are achieved using changes in the settings of the blade angles, achieved by changing the lengths of the blade control tension members. The lengths of all tension members changed by the same value so as not to disrupt the lifting rotor blade travel settings made earlier.

Further increase in the overall pitch of the lifting rotor results in no more change in the UPRT-2 reading, since the NR-23A levers have reached their stops, after which the gas corrector lever will move to the left by itself, since the rockers at rib No. 1, beginning with general pitch 9°, are at their lower stops. The upper position of the general pitch lever corresponds to 13.5° according to the indicator (point e). At this point, the pitch lever has been moved from its extreme lower position by 46°. At point e, the gas corrector will be deflected from its extreme right position by a certain angle (about 50°) toward the left. Deflection of the pitch lever from 9° to 13.5° (from point e to point f) in vertical flying modes, during vertical takeoffs and landings, will "make the lifting rotor too heavy," but is necessary for other flying regimes: at high altitudes and speeds, for autorotation landings and for landings at "high pitch" when absolutely necessary.

If the corrector is moved to the left with the rotor at maximum pitch, the indications of the UPRT-2 will decrease, down to about 58% at the left stop (point g). When the overall pitch is decreased with the corrector out, the indications of the UPRT-2 will decrease, and at 8° they should lie between 24-28% (point h); when a pitch of 5-6° is reached (idle), they should read 15-18° (point i). A further decrease in overall pitch will cause the corrector lever to move to the right by itself, since the rockers at rib No. 1 will have reached the upper idle stops. With a pitch of 1°, the corrector lever will be in its extreme position (point a on Figure 50). Consequently, with an overall pitch of the lifting rotor of 1°, the corrector lever will not be at full travel (101°), but only at half travel--50° (from point a to point b).

On Figure 50, on the sector of the curve with the corrector out (between points f and i) the rotating speed of the lifting rotor is not indicated, since this adjustment of the pitch-gas system is always performed with the engines off (cold characteristic). The shaded areas on Figure 50 indicate permissible readings of the UPRT-2 achieved by adjusting the pitch-gas system.

The characteristics of the pitch-gas system of the Mi-6 helicopter shown in Table 4 were measured with the helicopter tied down. If tie downs are not available, it is recommended that the pitch-gas system be tested using a vertical takeoff and hovering with normal flying weight. This check, like the check with the helicopter tied down, is performed after blade tip travel has been adjusted and cold regulation of the pitch-gas system has been tested; the UPRT-2 reading should correspond to those presented in Table 4.

The method to be used for this check is as follows. After starting and warming up the engine, the "pitch-gas" lever is moved to the lower position (1° on the pitch indicator), the gas corrector is rotated to the right to the stop, at which point the rotating speed of the lifting rotor should be between 76-80% (Table 5).

TABLE 5. CHARACTERISTICS OF PITCH-GAS SYSTEM (WITHOUT TIE DOWNS, HOVERING)

Pitch according to indicator, deg	rpm of rotor turbine, %	Hovering altitude, m	Notes
1	76-80	0	
2-4	83-87	0	Rotating speed can be increased to 90% for not over 1 min
6-8			
9+1°		3-5	
-30'	82-85 80-84	At least 6	Engine takeoff power

Subsequent checks are performed with the corrector to the right. Then the pitch is smoothly increased to 4°, and in the pitch range 2-4° the rotating speed of the lifting rotor increases to the maximum (83-87%) with brief (up to 1 min) increases to 90% allowed.

With a further increase in the pitch, the helicopter will separate from the ground and at 3-5 m altitude with pitch 6-8° the rotating speed of the lifting rotor should be 82-85%. After this, the engine should be moved to the takeoff regime, increasing the pitch, with the hovering altitude at least 6 m, and the rotating speed of the lifting rotor 80-84%. In this case, hovering can be performed at altitudes over 10 m.

These data for the pitch-gas system are presented for normal flying weight of the helicopter, with winds not over 3 m/sec and altitude not over 500 m over sea level.

The area described by the closed curve on Figure 50 represents the pitch of the lifting rotor and position of the gas corrector lever for establishment of various operating modes of the engine according to Table 1 and for performance of various flying modes of the helicopter throughout the entire range of speeds and altitudes.

Special flying tests have established that climbing with forward speed in the takeoff engine mode is performed with the corrector fully on to the right and pitch over 9° (zone 1, Figure 50 a). Climbing with forward motion at the nominal mode is performed with a pitch less than in the takeoff mode, but with some adjustment of the corrector from the far right position (zone 2), while in horizontal flight the pitch changes from 3 to 12° , depending on the flight speed and rotating speed of the lifting rotor. In order to increase the rotating speed, the corrector is moved further to the right (zones 3, 4). Descent with engines operating is performed with pitch from 3 to 8° with the corrector almost out (zone 5). Gliding with the fuel feed off is performed with small pitch ($1-2^\circ$) with the corrector out to the left, i.e., with the engines operating in the idle mode (zone 6).

Thus, in almost all flying modes, the pilot must use the gas corrector in order to establish the permissible operating speed, creating certain difficulties during piloting.

Further improvement of the pitch-gas system of the Mi-6 helicopter is planned, with the installation of a device for automatic maintenance of the rotating speed of the lifting rotor in all flying modes, plus a device designed to prevent excessive increases in the "weight" of the lifting rotor. With this system, the pilot controls only the pitch of the rotor, while the free turbine rotating speed regulator changes the fuel supply to the combustion chamber as required to maintain the preset constant lifting rotor speed. The lifting rotor speed regulator can have a single regime, i.e., the rotating speed of the lifting rotor can be maintained constant in all flying modes (for example, in the Mi-2 and Mi-8 helicopters). Even more highly perfected systems are used, in which the rotating speed of the lifting rotor may be varied as the pilot desires by adjusting the regulator, for example by setting the required rotating speed for a given flying regime with a knob.

The automatic device to maintain the rotating speed of the lifting rotor of the Mi-6 helicopter which is planned will not be the same as that used on the Mi-2 and Mi-8 helicopters. The control of the fuel valve will be achieved using a hydroelectric unit (tension member of variable length) which will open the fuel valve without interference by the pilot, upon receipt of signals from an electronic computer which in turn receives

signals from the lifting rotor as a function of its speed. However, the system also allows the rotating speed of the lifting rotor to be changed according to the desire of the pilot as a function of the flying regime, by adjusting the regulating system.

In order to prevent increasing "weight" of the rotor too much, an additional friction coupling is used, which makes movement of the pitch lever more difficult. For example, whereas the force on the pitch lever between 1 and 9° pitch is 0.5 kg, at pitch levels over 9°, the force increases to 10 kg. The increasing force will warn the pilot that the engines are operating in the takeoff mode and that a further increase in the pitch will make the rotor too "heavy." If this increase in rotor loading is dangerous in the slight mode being used, the pilot will not allow it; if an increase in loading is necessary during certain flying elements, the pilot can increase it, but it requires a harder push on the pitch lever.

CHAPTER IV. TAXIING, HOVERING AND VERTICAL FLIGHT MODES

§15. Taxiing

General Characteristics

Taxiing with the Mi-6 helicopter is the principle means used to move short distances, particularly near aircraft and other obstacles, since during flight over short distances a powerful airflow descends from the rotor, raising dust (or snow) and sometimes causing damage to aircraft and structures. However, this does not mean that taxiing can always be used; a number of limitations are placed on taxiing. The Mi-6 helicopter is subject to "ground resonance," and there is also some danger of tipping over with the three-wheel landing gear, high center of gravity and great mass of the helicopter. In order to avoid these problems, the thrust of the lifting rotor must be less than the weight of the helicopter.

The reactive moment of the lifting rotor in the taxiing mode is balanced by the torque provided by the tail rotor and partially by friction of the wheels on the ground.

The Mi-6 helicopter has good taxiing properties, high maneuverability and is relatively easy to control during taxiing, but there are certain difficulties, particularly in taxiing on slippery surfaces, when insufficient friction of the wheels may cause side movement known as slipping due to the great mass of the helicopter. Taxiing on dusty helicopter pads or fresh snow cover raises sufficient dust or snow due to the blast from the lifting rotor to decrease visibility to a greater extent than when taxiing in other helicopters, due to the great diameter of the lifting rotor and the great specific loading over the swept area.

The taxiing speed is maintained by changing the inclination and thrust of the lifting rotor using the cyclic and general pitch levers. The direction of taxiing is controlled by changing the thrust of the tail rotor using the pedals. The self-centering front landing gear wheel provides good maneuverability. The thrust of the lifting rotor and the brakes on the main landing gear wheels are used to decrease speed and for emergency stops.

If taxiing is impossible for some reason, flight at low altitude is permitted.

During taxiing, the following forces and moments act on the helicopter (Figure 51): the force of the thrust of the lifting rotor T , of the tail rotor T_{tr} , the drag of the helicopter X , the force of friction of wheels on the ground F_{fr} , the weight of the helicopter G , the reaction of the earth F_{re} , the reactive moment of the lifting rotor M_p , of the tail rotor M_{tr} and the track moment of the tail rotor. The force

of the thrust of the lifting rotor is deflected forward and to the right by the cyclic pitch lever, so that it is divided into three components: T_y --the vertical component; T_x --the horizontal component, directed forward and T_z --the horizontal component directed to the right. The force of the thrust of the tail rotor is directed to the left.

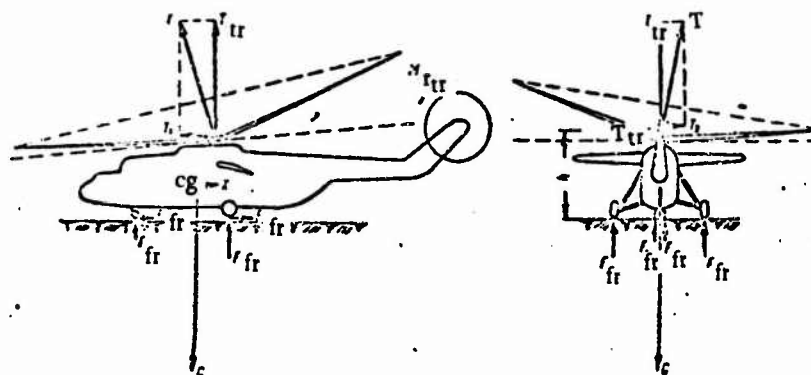

Figure 51. Diagram of Forces Acting on Helicopter During Taxiing.

The following equality of forces and moments must be maintained for even, straight line movement of the helicopter over the ground. Even movement requires that the horizontal component of the thrust of the lifting rotor be equal to the drag of the helicopter and the force of friction of the wheels on the ground

$$T_x = X + F_{fr}.$$

In order to prevent slipping of the helicopter along the ground and to reduce side pressures on the pneumatic tires, and to prevent the tendency toward tipping, the thrust of the tail rotor must be balanced by the side component of the thrust of the lifting rotor, i.e., $T_{tr} = T_z$. Straight line movement requires that the reactive moment of the lifting rotor be balanced by the track moment of the tail rotor

$$M_{Plr} = M_{y_{tr}} = T_{tr} l_{tr}.$$

Furthermore, in order to provide a stable position of the helicopter on the earth, the vertical component of the thrust of the lifting rotor must be considerably less than the weight of the helicopter.

Specifics of Performance of Taxiing

In order to begin taxiing, with a general pitch of 1° ; the gas corrector is rotated fully to the right, then the pilot waits until the speed of the lifting rotor reaches 78-82% (slight increases in general pitch to not over 2° are allowed). The levers for separate control of the two engines should be in the neutral position--in the slots. Until the required rotating speed is reached, the longitudinal tremor is placed in the neutral position, the transverse tremor is placed 0.5-1.5 divisions to the right. Then the cyclical pitch lever is moved smoothly forward and the helicopter begins to roll. If the helicopter does not begin moving when the lever is pushed forward, the general pitch must be increased, but not to over 2° , then after the helicopter starts moving, the general pitch should be decreased to its minimal value.

When the helicopter is started taxiing, particularly on soft ground or poorly packed snow, the cyclical pitch lever should not be moved forward all the way, since this increases the loading on the front wheel and causes the force of friction to rise. It is also not recommended that the general pitch be increased to over 2° , causing an increase in the thrust and reactive moment of the lifting rotor and the thrust of the tail rotor, a decrease in friction with the ground, resulting in movement of the helicopter to the left as a result of the increasing thrust of the tail rotor, which may lead to wedging of the left wheel in the soft ground or snow and cause a strong tipping moment. The helicopter should not be rocked with the pedals to start it taxiing, since this might cause breakage of the tail beam and tail rotor.

The taxiing speed should not be over 20 km/hr. It should be changed using the cyclical pitch lever, or using the general pitch lever on uneven, soft ground. Taxiing should be performed with full right correction, maintaining the rotor speed between 78-82%. Long taxiing can be performed with the longitudinal tremor at 0.5-1 scale division forward.

Turns during taxiing are performed by smoothly moving the pedals. The higher the speed, the larger should be the radius of the turn. Sharp turns with small radius are not permissible, since even on firm surfaces the helicopter may begin to slide due to the great centrifugal force acting toward the outside of the turn. Slipping may also arise with normal turns if a thrust is too high, when the helicopter is nearly suspended, or

during straight line taxiing on soft or slippery surfaces. When slipping starts, taxiing should be stopped, by decreasing the engine power to the minimum, turning the pedal in the direction of the slip, waiting for the helicopter to stop, and only then can the taxiing or turn be resumed at a lower speed.

When taxiing with a side wind, the helicopter will try to turn nose into the wind; therefore, this turn should be countered with the proper pedal. Furthermore, the cone of rotation and thrust of the lifting rotor will be pushed away with the wind and side force T_z will be greater than required if the wind is from the left, less than required if it is from the right. Therefore, the cyclical pitch lever should be deflected in the direction opposite to the wind.

When taxiing over dusty or sandy soil with a head wind of over 5 m/sec, the visibility is good, since all the dust raised by the lifting rotor at all taxiing speeds will be carried away to the rear. With a head wind of less than 5 m/sec, in calm weather or with a tail wind, visibility is considerably worse. Therefore, the helicopter should be taxied with halts at certain intervals (20-25 m) or at slightly higher speed, in order to taxi away from the dust cloud. The same procedure should be used in taxiing over a snow covered heliport.

To stop the helicopter, the engine power should be decreased to the minimum (general pitch 1° , left correction), the cyclical pitch lever should be pulled smoothly back toward the pilot and the brake should be applied.

Limitations During Start Up of Engines and Taxiing

1. Start up of engines, winding up of engines, stopping of the lifting rotor and taxiing are permitted with the following wind speeds and directions: head wind--25 m/sec, side wind--15 m/sec, tail wind--12 m/sec.

2. When there is a side wind, the engine on the leeward side is started first, since this improves the starting conditions for the engine on the windward side: the load on the engine is decreased due to the rotation of the free turbine by the engine started first.

3. During separate testing of engines without tie downs, the helicopter should have a weight of at least 33,000 kg (unloaded, but with main fuel tanks full), or for testing both engines simultaneously--about 42,000 kg.

4. Before starting the engines, the longitudinal trimmer should be set 1-1.5 scale divisions to the rear, the transverse trimmer 0.5-1 scale divisions to the right. With this position of the trimmers, the automatic

swash plate will take up a neutral position, the pitch will not change cyclically, the blades will not flap and therefore the blades will not strike the stops of the flapping hinges.

5. During taxiing, the rotating speed of the lifting rotor should be 78-82%.

6. The taxiing speed should not exceed 20 km/hr, or when taxiing on dusty or sandy heliports, not over 30 km/hr, or on snow covered heliports-- not over 10 km/hr.

7. Turns in place are not permitted on snow covered areas, since this might burst the tires of the wheels or break the support of the nose wheel. Taxiing over ground which is too soft or uneven or over deep, loose snow is forbidden.

§16. Hovering

General Characteristics

The hovering mode is the principle design flying mode for the Mi-6 helicopter.

Hovering is used to test the operation of the engines, transmission, control systems and centering system; it is a component part of vertical flight and landing both with cargoes within the cabin and with cargoes suspended on a hook.

Figures 23, 24 and 25 show the aerodynamic characteristics of the Mi-6 helicopter lifting rotor in the hovering mode. We can see from these characteristics that the lifting rotor develops a thrust near the flying weight of the helicopter only in the zone of influence of the air cushion. From this, we can conclude that the hovering ceiling of the helicopter with normal and maximum flying weight under standard atmospheric conditions above sea level is not very high. For example, with a helicopter weight of 42 T, the maximum hovering height is 2 m; with a weight of 40 T--6 m; with a weight of 39 T--8 m and with a weight of 38 T--10 m. Therefore, if higher hovering heights are required for the performance of various operations, the flying weight must be decreased or favorable atmospheric conditions must be awaited.

Figure 52 shows the required engine power for hovering according to the indications of the UPRT-2 device in degrees and the ITE-2 device in percentage points at various altitudes and with various flying weights. These indications were produced as a result of flying tests under atmospheric conditions near the standard conditions at sea level. As we can see from the curves of this graph, the higher the flying weight of the helicopter and the higher the altitude, the more engine power is required

for hovering. A helicopter weighing 42 T will hover at an altitude of about 4 m in the engine takeoff mode (UPRT-2--97°, ITE-2--94%). With this same engine operating mode, the hovering altitude increases as helicopter weight decreases.

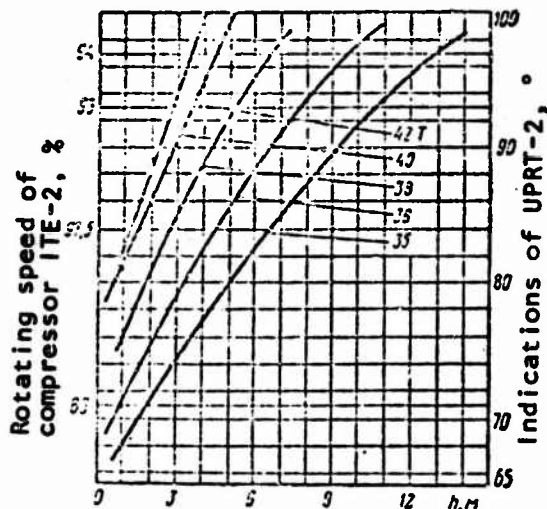

NOT REPRODUCIBLE

Figure 52. Required Engine Power as a Function of Weight and Altitude in Hovering.

The Mi-6 helicopter, like the Mi-4, is balanced in the hovering mode with a right bank of 2° with cargo placed symmetrically in the cabin along the transverse axis and with a positive pitch angle which depends on centering: with limiting forward centering, the pitch angle is 3.5°, with limiting rear centering it is 10°. Due to the nonlinearity of the control system, in order to provide ease of piloting at cruising flight speeds, the control levers occupy the same positions in hovering as in the Mi-4 helicopter: the cyclical pitch lever is shifted to the rear and right from the neutral position, the right pedal is pushed forward.

During hovering, the indications of longitudinal and transverse trimmers with no pressure on the control levers can be used to determine the centering of the helicopter. If the longitudinal trimmer is deflected to the rear by 2.5 divisions, the centering is at the limiting forward stage, if it is over 2.5 divisions--the centering is beyond the maximum permissible forward stage; if the longitudinal trimmer is 0.5 divisions forward, the centering is at the maximum rearward stage, while greater deflection of the trimmer indicates that the centering is too far rearward. With the trimmer at 0.5-1 division to the rear, the centering is moderate, while deflection of the transverse trimmer by 0.5-1.5 divisions to the right falls within the limits of the norms.

Maneuvering is permitted with the Mi-6 helicopter hovering, but with certain limitations in order to assure safety.

Diagram of Forces and Moments Acting on the Helicopter

During hovering, the following forces and moments act on the helicopter (Figure 53): the aerodynamic force of the lifting rotor R , the thrust of the tail rotor T_{tr} , the drag of the fuselage X due to the passage of the inductive flow around it, the lift of the wing and stabilizer due to the inductive flow of the lifting rotor U_w and U_{st} , the weight of the helicopter G , the reactive moment of the lifting rotor M_{pr} , the track and reactive moments of the tail rotor, the longitudinal and transverse moments of the hub due to the displacement of the horizontal hinges $M_{z_{hb}}$ and $M_{x_{hb}}$.

The aerodynamic force of the lifting rotor and the cone of rotation are deflected to the right. The aerodynamic force is broken down into thrust T and lateral force T_z . The thrust of the tail rotor is directed to the left and due to the lever to the center of gravity of the helicopter creates a track moment directed in the opposite direction to the reactive moment of the lifting rotor. The drag of the fuselage X is directed downward and for a single rotor helicopter amounts to about 1.5% of the flying weight. The lift of the wing in the hovering mode is directed downward and in the Mi-6 helicopter is about 2% of the flying weight. The lift of the stabilizer creates a pitching moment which is very slight in magnitude and is ignored in practice, although the moment created by this force is considered. The reactive moment of the tail rotor is directed in the direction opposite to its rotation and creates a pitching moment. The longitudinal moment of the hub resulting from the displacement of the horizontal hinges causes a pitching moment, since the cone is most frequently tilted somewhat backward in the hovering mode. The transverse moment of the hub is directed to the right, in the direction of the displacement of the cone of rotation, creating a bank to the right.

The following relationship between forces in moments acting on the helicopter must be observed in order to balance the helicopter in a stable hover. The thrust should balance the weight component G_y , the drag of the fuselage and the lift of the wing in order to retain constant hovering altitude: $T_y = G_y + X + Y_w$.

The thrust of the tail rotor must balance the lateral force T_z and the weight component G_z : $T_{tr} = T_z + G_z$. In order to maintain the orientation during hover, the reactive moment of the lifting rotor and the track moment of the lateral force should be balanced by the track moment of the

tail rotor $M_{Plr} + T_z \cdot a = M_{tr} = T_{tr} \cdot l_{tr}$. The sum of all longitudinal moments should be equal to zero to preserve longitudinal equilibrium. The sum of all transverse moments should be equal to zero to preserve transverse equilibrium.

Specifics of Piloting and Maneuvering in the Hovering Mode

Before vertical separation, the longitudinal trimmer is set 0.5-1 divisions back, the transverse trimmer 0.5-15 divisions to the right in order to remove the pressure which arises on the vertical pitch rotor during hovering. The gas corrector is moved fully to the right, and when the rotating speed of the lifting rotor reaches 78-82%, the general pitch lever is moved smoothly upward to separate the helicopter from the ground and climb to the required altitude. At the same time, the control lever and pedals must be used to prevent the tendency of the helicopter to rotate, bank and move forward. The D-25V engine is not as responsive as a piston engine, so the rate of movement of the general pitch lever from the lower position to the moment of separation of the helicopter from the ground must be slow and smooth (over 5-7 sec), since otherwise the lifting rotor may be overloaded, leading to a decrease in thrust and involuntary loss of altitude or relanding after separation. During separation and climbing, the rotating speed of the lifting rotor increases; it must be held, using the gas corrector, between 80-82%. The minimum permissible rotation speed is 78%, the maximum is 87% or 90% briefly (up to 1 min). In the Mi-6 helicopter, during takeoff, vertical climb, hovering and also vertical descent, it is recommended for proper determination of the position of the helicopter in space that the pilot look 15-20° to the left of the longitudinal axis of the helicopter, 25-35 m forward of the nose. The Mi-6 helicopter, like the Mi-4, is held in hovering using all control levers: in altitude--using the general pitch lever, with the rotating speed held between 80-82%; in direction--using the pedals, in hovering locations--using the cyclical pitch lever. In a delay in working the control levers, particularly the cyclical pitch lever in the longitudinal direction, will cause considerable movement of the helicopter; therefore, movements of the lever should be smooth and simultaneous.

Maneuvering of the Mi-6 helicopter in the hovering mode, as is the case with the Mi-4, can be in altitude, direction or hovering location. The methods of maneuvering and the behavior of the helicopter are the same as for the Mi-4, but with different flying limitations.

Flying Limitations During Hovering and Maneuvering

Limitations of flying altitude. Hovering is permitted with no limitations at up to 10 m altitude, from 10 to 250 m only when flying with cargoes suspended externally, during rescue operations, emergency medical aid and during takeoffs and landings from type 2 heliports or areas

corresponding to them¹. In case of failure of the engines at heights of 10-250 m, landing by the autorotation mode is somewhat dangerous. However, since the engines operate reliably, operations at these altitudes are performed when clearly necessary. At altitudes over 250 m, the helicopter should maintain an indicated speed of no less than the minimum permissible speed in horizontal flight at the altitude used, since the helicopter has no low speed indicator the pilot may err and the helicopter may travel at low air speeds, resulting in high vibration--the "shaking mode."

The hovering height during vertical takeoffs and landings from type 1 heliports² (in the zone of influence of the air cushion) is 2-3 m. The height of test hovering during vertical takeoff from heliports located at altitudes up to 500 m above sea level is 5 m, while for heliports located at altitudes above 500 m over sea level the height of test hovering is determined using a special nomogram. When taking off from type 2 heliports, the height of hovering should be at least 10 m over obstacles, while when taking off or landing with cargoes suspended externally it should be at least 3 m from cargo to surface.

Limitations as to speed and altitude. Movement in any direction can be performed at speeds of not over 15 km/hr. The altitude of the helicopter during movements over level terrain should be at least 2-3 m, over obstacles at least 10 m. Movement over aircraft and other helicopters is forbidden.

Wind limitations. Hovering, as well as takeoffs, landings and approaches are permitted with head winds of up to 25 m/sec, tail winds up to 10 m/sec and side winds up to 5 m/sec. Therefore, with a wind of up to 5 m/sec, the helicopter can be turned in place by 360°, with a wind of 5-10 m/sec--at an angle of not over 90° to the wind direction, with a wind of over 10 m/sec, turns in place cannot be performed, hovering can be performed only nose into the wind. With wind speeds of over 25 m/sec, starting the engines and flying are forbidden. With cargoes suspended externally with a flying weight of the helicopter of over 36 T, turns while hovering are also forbidden.

Limitations as to turning speed. Turns while hovering should be performed at speeds of not over 10° per second, i.e., the time of a full rotation should be at least 36 sec. During turns, and also during any other type of flying, sharp movements of the pedals, particularly passing through the neutral position, are not permitted.

¹Type 2 heliports are those requiring vertical takeoff and landing.

²Type 1 heliports are those which allow airplane type takeoffs and landings, or takeoffs and landings using the influence of the "air cushion."

NOT REPRODUCIBLE

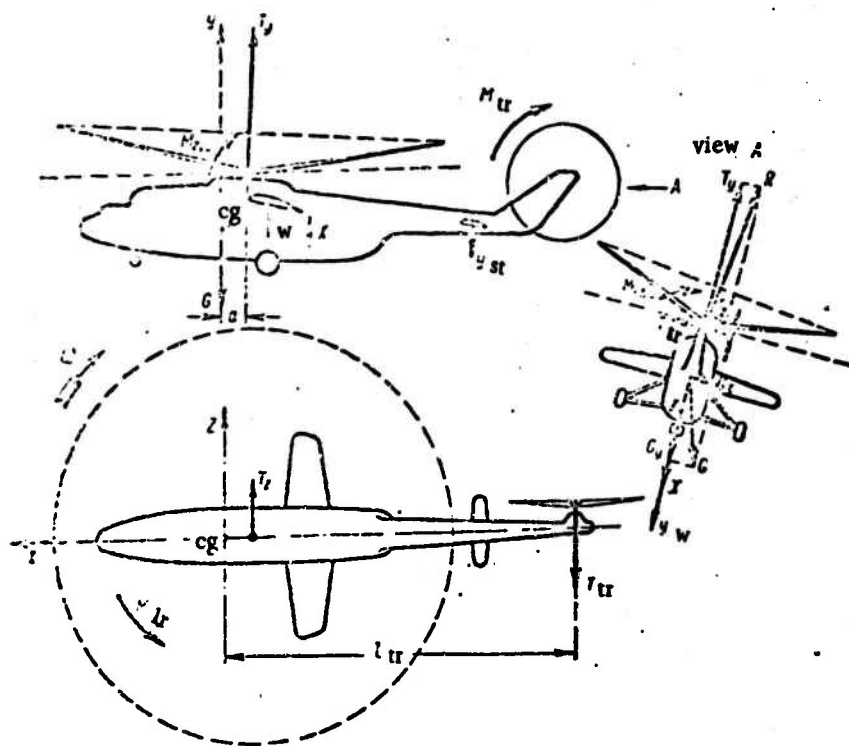

Figure 53. Diagram Forces of Moments Activity on Helicopter Hovering and in Vertical Flight.

§17. Vertical Flying Modes of the Helicopter

General Characteristics

The vertical flying modes of the helicopter include vertical climbing and vertical descent with engines operating. The vertical flying modes of the helicopter, like the hovering mode, are uneconomical and difficult as concerns piloting techniques. In these modes, the power reserve is low and the control reserve is insufficient, particularly the pedal reserve; the stability of the helicopter is insufficient. For these reasons, the usage of vertical modes is limited; they are used only when necessary.

Vertical flying modes are used during vertical takeoffs and landings both with cargo in the cabin and with cargo on the external hook, during various construction, installation, rescue and other operations.

During vertical flying, the same forces and moments act on the helicopter as during the hovering mode (see Figure 53). During a climb, the vertical thrust component must be greater than during hovering, since the drag of the helicopter and negative lift of the wing increase due to the upward movement of the helicopter. The lateral component of the thrust

of the lifting rotor T_z should also be greater than during hovering, since the pilot must increase the thrust of the tail rotor due to the increased reactive moment of the lifting rotor, and it is necessary in order to prevent lateral movement that the lateral force be equal to the thrust of the tail rotor. During a vertical descent, the thrust of the lifting rotor should be less than during hovering, since the drag of the fuselage and lift of the wing, although they are still directed downward, as in hovering, are less in magnitude. The lateral force and thrust of the tail rotor should also be equal during stable descent, but are less than during hovering.

With increasing altitude, the required power for hovering, and therefore for vertical climbing as well, increases, while the available power is retained unchanged up to the design altitude, so that the excess power available decreases, leading to a decrease in the vertical rate of climb. The altitude at which the excess power is equal to zero is the hovering ceiling of the helicopter. As was established earlier, the reserve of power of the Mi-6 helicopter during hovering is slight, so that the hovering ceiling of the helicopter is nonexistent for normal and maximum loads. In order to achieve hovering at high altitude, in or out of the zone of influence of the air cushion, the flying weight of the helicopter must be decreased.

Vertical climbing may cause overloading of the lifting rotor, and a vertical descent at high speed may cause the lifting rotor to enter the vortex ring mode.

Specifics of Performance of Vertical Flying Modes

Vertical climb. In order to go over from the hovering mode to the vertical climbing mode, the general pitch lever must be moved smoothly upward, and, in order to counter the increasing reactive moment, the right pedal must be moved forward and the lever must be moved to the right, while retaining the rotating speed, as in hovering, at between 80-82%. One characteristic feature of this mode is that during a vertical climb, in order to retain the required rotating speed, the pilot must not only use the general pitch lever, but the gas corrector knob as well. The vertical climbing speed should be slight, since the reserve of power and hovering ceiling are low, since otherwise inertia may cause the helicopter to reach a height higher than the hovering ceiling, after which it will descend again independently.

In order to stop a vertical climb, the general pitch lever should be lowered smoothly and then the helicopter can be retained at the required altitude by moving the general pitch lever.

Vertical descent. In order to go over from the hovering mode to the vertical descent mode, the "pitch-gas" lever should be moved downward

smoothly to decrease the general pitch of the lifting rotor, providing a vertical descent speed of not over 1-2 m/sec. A coordinated movement of the left pedal forward (releasing pressure on the right pedal) and of the cyclical pitch lever to the left will prevent turning and displacement of the helicopter to the right as a result of the decreased reactive moment of the lifting rotor and the thrust of the tail rotor.

The descent speed should be 1-2, not over 3 m/sec. At speeds over 3 m/sec, the lifting rotor will enter the vortex ring mode, which is particularly dangerous at low altitudes, at which it is difficult to bring the helicopter out of vortex ring modes. If the vertical descent is continued to landing, beginning at 5 m altitude, the vertical rate of descent must be decreased by moving the general pitch lever upward so that the rate of descent by the point of landing is not over 0.1-0.2 m/sec. If the descent is performed in order to reach a fixed altitude, the general pitch lever is moved upward in order to decrease the vertical rate of descent to zero at the required altitude.

During vertical descent, as during climbing and hovering, the rotating speed of the lifting rotor should be maintained between 80-82%.

Flying Limitations on Vertical Flying Modes

1. During a vertical climb or descent, other maneuvers are forbidden, except for takeoff with cargo on the external hook; therefore, limitations for these regimes are only expressed in altitude. They are the same as for hovering: from the ground up to 10 m, they can be performed without limitations, at altitudes of from 10 to 250 m, only in special cases, at altitudes over 250 m these regimes are forbidden for the same reasons as applied to the hovering regime. The speed during a climb or descent at altitudes over 250 m should be no less than the minimum permissible speed for climbing or descending at the altitude in question.

2. A vertical climb or descent should be performed with a head wind, but since these regimes are usually used for takeoff and landing, which would require rotating the helicopter while still on the ground, these modes can be used with side winds or tail winds (side wind speed not over 10, tail wind speed not over 5 m/sec).

3. The vertical rate of descent should not exceed 3 m/sec.

CHAPTER V. TAKEOFF AND CLIMB WITH FORWARD SPEED

§18. Takeoff

General Information

Depending on conditions, the Mi-6 helicopter can take off like an airplane or vertically. The airplane type takeoff is the main type used for the Mi-6 helicopter, since it requires less power. The helicopter can take off with high flying weight, increasing the weight performance and commercial payload capacity or increasing the flying range by increasing the quantity of fuel. All of this improves the economic effectiveness of the helicopter, which approaches that of Stol aircraft. Calculations and flying tests have shown that the airplane type takeoff can increase the flying weight by 15% in comparison to the maximum which can be carried with a vertical takeoff. The required run is not over 60-100 m. When the maximum weight is increased by 15% over the normal weight, the main wheels must be separated during the run, the run then being completed on the front wheel, since this decreases friction and the increasing thrust of the lifting rotor with increasing speed allows the overloaded helicopter to take off.¹ This method of takeoff for helicopters is not yet to be found in the regulations, since it requires an increase in the strength of the front landing gear support. However, since the support is not designed for this type of takeoff, at the present time the maximum weight of the helicopter is not 15% over the normal weight, but rather somewhat less. For the Mi-6 helicopter used in civil aviation, the normal flying weight is established at 40,500 kg, the maximum--at 42,500 kg. When an airplane type takeoff is used with speed picked up on the takeoff run, increased vibration ("shaking regime"), observed when speed is picked up after separation, is not noted. With the airplane type takeoff, the helicopter uses a rather long run-length and takeoff distance, so that these takeoffs can only be used from permanent heliports or type 1 temporary heliports for heavy helicopters.

The maximum permissible takeoff weight for a vertical takeoff is determined from nomograms. The nomograms have not yet been written for determination of run length in an airplane type takeoff or takeoff distance for both types of takeoff, since the Mi-6 helicopter is used at heliports for which certain technical requirements are standard. These requirements establish the size of the takeoff runways, air approaches, areas of

¹M L. Mil' et. al., *Vertolety. Raschet i Proyektirovaniye* [Helicopters. Design and Planning], Book I, Aerodynamics, Chapter 1, Mashinostroyeniye Press, 1966.

limitation of obstacles, slopes of heliport areas for type 1 and type 2 heliports depending on their altitude above sea level for various types of helicopters: light, medium and heavy (Mi-6). These technical requirements have been developed on the basis of comprehensive flying tests of all helicopters under various atmospheric conditions, changing on the average during the course of a year, and also on the basis of the elevation of the heliport above sea level. Type 1 heliports for each given type of helicopter (light, medium, heavy) have the same dimensions and slopes of approach strips and limitations of obstacles for a given elevation over sea level, allowing takeoffs and landings to be performed using either method at any time of year and any time of day. Type 2 heliports allow takeoffs and landings to be performed vertically outside the zone of influence of the air cushion, also any time of day or year. Therefore, when taking off from this type of heliport using one of the methods described and at the corresponding flying weight, the pilot can be sure that he is flying safely. A landing in which the area of landing is selected from the air is forbidden for the Mi-6 helicopter, except for forced landings.

Takeoffs of the Mi-6 helicopter from dusty, sandy or snow covered heliports is difficult due to the poor visibility, just as is taxiing at these heliports.

Airplane Type Takeoff

The airplane type takeoff, the main type used by the Mi-6, is performed from airports and type 1 heliports, with artificial or natural runways, but only with the cargo inside the cabin. The airplane type takeoff consists of the following stages: takeoff run, separation, further acceleration to 90 km/hr with simultaneous climb to 25-30 m and subsequent increase in speed to the optimal speed of 140 km/hr (Figure 54).

Before the takeoff, the general pitch lever is set in the lower position, the gas corrector knob is rotated fully to the right and, when the rotating speed of the lifting rotor reaches 78-82%, the cyclical pitch lever is pushed forward, with a simultaneous increase of the general pitch, and the takeoff run begins. During the run, the cyclical pitch lever is not pushed fully forward, but rather just enough to prevent separation of the main wheels, to prevent the helicopter from resting on the front wheel. During the takeoff run, the same forces acts on the helicopter as during taxiing (see above).

At 50-60 km/hr, the helicopter is separated from the ground by a smooth movement of the general pitch lever of the lifting rotor until the takeoff mode is reached, and at the same time the cyclical pitch lever is pulled back. When this is done smoothly with both hands, the thrust of the lifting rotor increases due to the increased pitch of the rotor, power of the engines and angles of attack of the lifting rotor blades.

After separation, the acceleration must be continued with simultaneous increase in altitude, since the influence of the air cushion is no longer felt, so that the helicopter must be maintained in the well-known safe "corridor" in case of engine failure. Furthermore, after separation, as the helicopter picks up speed, it shows a tendency to increase the pitch angle and to bank over to the right (due to the movement of the axis of the cone of rotation to the rear and right) which must be countered by moving the cyclical pitch lever forward and to the left.

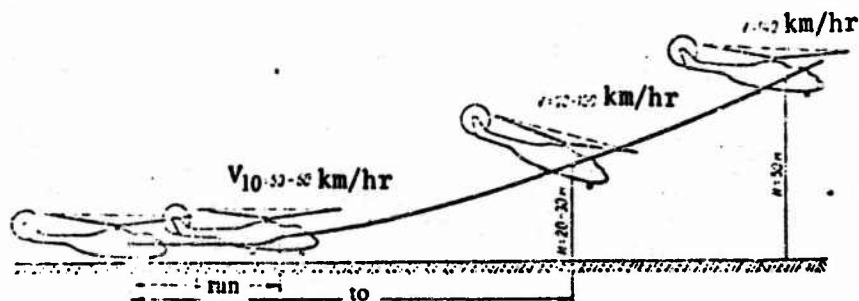

Figure 54. Profile and Elements of Airplane Type Takeoff of Mi-6 Helicopter.

The length of the takeoff run and takeoff distance depend on the flying weight of the helicopter, the speed of separation, the atmospheric conditions and the condition of the runway. Repeated flying tests of helicopters carrying various flying weights under various atmospheric conditions at heliports with artificial paving at various altitudes above sea level have shown that the takeoff runway is 180-370 m, the takeoff distance 580-860 m. For this reason, runway lengths at heliports for heavy helicopters (Mi-6) are made from 300-650 m, depending on the altitude of the heliport above sea level (the higher the altitude, the longer the runway), quality of pavement and whether the heliport is to be used for round-the-clock or daytime only operation (the runway length is greater for round-the-clock operation). The "ground resonance" may occur during an airplane type takeoff.

An airplane type takeoff with the Mi-6 helicopter is possible with side winds up to 10 and tail winds up to 5 m/sec. With a side wind, during the takeoff run the helicopter will attempt to turn nose into the wind, which must be countered by the corresponding pedal movement. Furthermore, with a side wind a separation may occur with some bank and subsequent displacement (drift). In order to prevent this, the bank must be countered by moving the control lever in the direction opposite to the wind. After separation from the runway, drift is prevented by banking in the direction opposite to the wind, and the tendency to turn into the wind is countered by movement of the pedal in the direction of the wind. At over 50 m altitude, the drift is countered by selecting the proper course.

76

When the Mi-6 is operated on dusty or snow covered heliports, airplane type takeoff should be performed against the wind. If the wind speed is over 5 m/sec, this type of takeoff is no different from an ordinary takeoff, since the dust or snow will be blown away to the rear. If the wind speed is less than 5 m/sec then, depending on the size of the heliport, separation should be performed at various speeds: the less the runway length, the less the speed of separation of the helicopter. Furthermore, in all cases the run is performed until sufficient speed is attained to provide visibility while maintaining the course using the GIK-1 compass. When a speed of 30 km/hr is reached, good visibility will develop, since the dust or snow cover will be left behind.

Brief description of method of takeoff. After checking the instruments and receiving permission for takeoff, the gas corrector is moved into the far right position and held there until the rotating speed reaches 72-82%, for which the general pitch can be increased by 1.5-2°. Then the run is begun by smoothly moving the cyclical pitch lever forward with simultaneous movement of the general pitch lever backward. During the run, forward directional stability is maintained by moving the pedals smoothly as required. The cyclical pitch lever should be moved forward only slightly, to be sure the helicopter does not roll forward onto the front wheel. When a speed of 50-60 km/hr is reached, the general pitch lever is moved further upward until the takeoff regime is reached (until the UPRT-2 reads 97-100%) and the cyclical pitch lever is moved back to cause the helicopter to rise off the ground. After separation, acceleration is continued together with gradual increase in altitude so that by the time 90-100 km/hr forward speed is reached, the altitude is 25-30 m. Then the speed is increased to 140 km/hr, the engines are put in the nominal operating mode (84-85° according to the UPRT-2) and the stable climbing mode is set, retaining the lifting rotor rpm at 83% ± 1% (for the helicopter with trapezoidal blades) or 79% ± 2% (for the helicopter with rectangular blades).

With a side wind, the tendency to turn and bank during the takeoff run is compensated by moving the control lever into the wind and deflecting the pedals with the wind. After separation, drift is eliminated by slipping into the wind, then after an altitude of 50 m is reached--by proper course selection.

Vertical Take off

This type of takeoff is used if it is impossible to use an airplane type takeoff, when the type of heliport requires it or when the takeoff is being performed with cargo suspended externally and in other similar cases. The vertical takeoff can be divided into two types: takeoff using the air cushion and takeoff outside the influence of the air cushion.

Vertical takeoff using the air cushion is performed from permanent or temporary type 1 heliports, the dimensions and approach strips of which allow this type of takeoff to be performed, and where the type of soil or small obstacles prevent a takeoff run.

In this case, in order for the takeoff to be performed the engine power reserve must be sufficient to support hovering at the required altitude, requiring that the helicopter be loaded correspondingly. The maximum permissible flying weight for this type of takeoff is determined from the nomograms considering the influence of the air cushion (Figure 55).

NOT REPRODUCIBLE

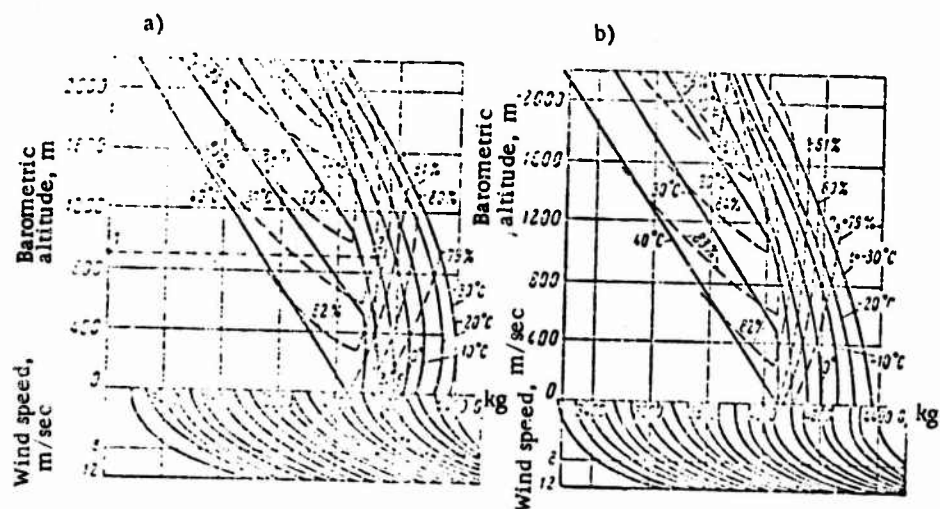

Figure 55. Nomograms for Determination of Flying Weight of MI-6 Helicopter During Takeoff and Landing Using Air Cushion: a, Rectangular blades; b, Trapezoidal blades.

These nomograms are constructed individually for helicopters with rectangular and with trapezoidal blades. The upper portion of the nomogram shows the maximum weight of the helicopter with the engine in the takeoff operating mode at a height of 5 m as a function of barometric altitude and temperature of the air; the lower portion of the nomogram shows the dependence on speed of head wind. In the upper portion of the nomogram, the dotted lines show the rotating speed of the lifting rotor providing a right pedal travel reserve of 10 mm in the hovering mode at this altitude.

Before the takeoff, a test hover is performed in order to be sure that the takeoff weight and loading has been calculated properly: if the helicopter climbs to 5-6 m and hovers stably with the engine operating mode at less than takeoff mode, the takeoff is possible. This test hover is also necessary due to the fact that the thrust of the lifting rotor in the takeoff mode varies from engine to engine as a result of varying

adjustment of the engine and lifting system of each individual helicopter. Then, the helicopter should descend to an altitude of 2-3 m and accelerate in the area of influence of the air cushion. Due to the decrease in power at this altitude, the reserve of right pedal movement increases to 20 mm. If the helicopter hovers at an altitude of less than 5-6 m in the takeoff mode, the takeoff cannot be performed. The flying weight must be decreased, or if it impossible or not expedient to decrease it, an airplane type takeoff should be made if the heliport allows it. This requirement is necessary in order that during the acceleration from the hover at 2-3 m there will be a reserve of power to prevent descent of the helicopter and contact of the wheels with the ground. If the helicopter hovers in the takeoff regime at over 5-6 m, it can be additionally loaded if necessary.

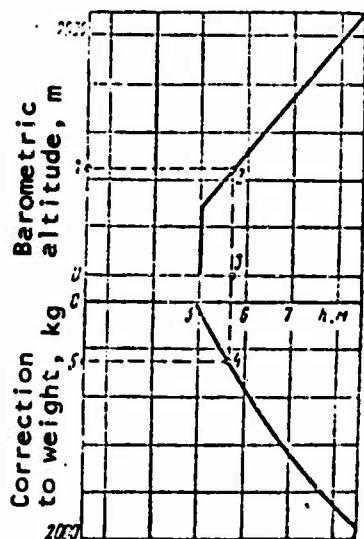

Figure 56. Nomogram for Determination of Corrections to Limiting Weight of Mi-6 Helicopter and Altitude of Test Hover for Vertical Takeoff in the Zone of Influence of Air Cushion Depending on Barometric Altitude of Heliport.

The nomogram is used to determine the maximum thrust of the engines in the takeoff mode and the maximum permissible flying weight of the helicopter at 5-6 m, although the hover before the takeoff acceleration run is performed at 2-3 m. This reserve in altitude and consequently in power is necessary to prevent descent of the helicopter during acceleration. These limitations are calculated for heliports with barometric altitude over sea level not over 500 m.

If the altitude of the heliport is over 500 m, the tendency to descend at the beginning of the acceleration run increases, so that the height of the test hover must be increased, by decreasing the flying weight of the helicopter.

The correction to the flying weight of the helicopter and the altitude of the test hover is determined using a special nomogram (Figure 56). Then the maximum permissible takeoff weight is determined as the difference between the weight produced from the nomogram (see Figure 55) and the correction produced from the second nomogram (Figure 56).

The test hover is performed at an altitude determined from the nomogram. If the helicopter hovers stably at this altitude in the takeoff engine operating mode, then calculation of the flying weight of the helicopter and its loading have been performed correctly, and the takeoff is possible.

The following is an example of the usage of the nomogram.

Given: barometric altitude of heliport 900 m, air temperature $+10^{\circ}\text{C}$, wind speed 6 m/sec, rotor with rectangular blades.

Solution: on the vertical axis of the graph (Figure 55) we find altitude 900 m (point 1) and draw a horizontal line to its intersection with the temperature curve corresponding to 10°C (point 2). Then we drop a perpendicular to the horizontal line of flying weight (point 3). Point 3 corresponds to the takeoff point of the helicopter under still conditions, 41,300 kg. In order to determine the maximum permissible takeoff weight with a head wind of 6 m/sec, we draw a line from point 3 equidistant to the curves on the lower portion of the graph, until it intersects the wind speed line corresponding to 6 m/sec (point 4). From point 4 we draw a vertical line to the intersection with the horizontal line for takeoff weight (point 5). We read off the answer: maximum permissible takeoff weight 42,250 kg. Point 2, the intersection of the horizontal line to the temperature curve, is located between the curves for the rotating speed of the lifting rotor corresponding to 81 and 82%. Consequently, the minimum permissible rotating speed of the lifting rotor in order to achieve a right pedal travel reserve of 10 mm is 81.5%.

Since the barometric altitude of the helicopter is over 500 m, we must find the correction to the takeoff weight and test hover height using the second nomogram (Figure 56). An example of the solution is shown by the dotted lines with arrows and numeration of points.

Answer: the test hover height is about 6 m, correction to takeoff weight 500 kg. Consequently, the maximum permissible takeoff weight is $42,250 - 500 = 41,700$ kg.

A vertical takeoff in the zone of influence of the air cushion consists of the following stages: vertical separation to test hover height, test hover at this height, vertical descent to 2-3 m, hover at this height, acceleration to 50-60 km/hr and transition to climb with further increase in speed (Figure 57).

After hovering at 2-3 m, acceleration is performed at the same altitude in the zone of influence of the air cushion. When the speed of 50-60 km/hr is reached, the influence of the air cushion disappears and the pilot can go over to the climbing mode, as in an airplane type takeoff, so that by the time a speed of 90-100 km is reached, the altitude

is 25-30 m. Then acceleration is continued to 140 km/hr, after which the nominal operating mode of the engines is used.

Over weighting of the lifting rotor are possible, both in the vertical climb, and during acceleration after hovering, in which case the pilot must increase engine power to prevent descent.

When the speed is increased in the 20-60 km/hr range, the entire helicopter vibrates ("shaking regime"). The acceleration should be performed as rapidly as possible in order to decrease the vibration, although not too rapidly, in order to prevent descent of the helicopter, which will occur if the cyclical pitch lever is moved forward too rapidly.

When a speed of 60-70 km/hr is reached, the helicopter is noticeably unbalanced, i.e., tends to increase the pitch angle, climb rapidly, bank and rotate to the right due to dropping of the cone of rotation to the right and the increased thrust of the tail rotor resulting from inclined airflow. The helicopter must be balanced in the required position by coordinated movements of all control levers in order to maintain the trajectory.

During the process of acceleration, as a result of lightening of the rotor its speed will increase, and the weight of the rotor must be increased in order to hold the rotating speed within the required limits.

During takeoff with limiting rear sintering, the reserve of longitudinal control away from the pilot is decreased, particularly in the takeoff mode, so that the cyclical pitch lever must be moved forward smoothly, in order to be sure that the front stop is not reached. If this occurs, the rotating speed of the lifting rotor can be increased and the speed of the helicopter decreased.

Limitations as to wind allowable during a vertical takeoff are the same as those allowed during an airplane type takeoff. One must recall that a side wind is more dangerous during a vertical takeoff at the moment of separation of the helicopter from the earth than during acceleration. Therefore, if the acceleration is to be performed with a side wind of about 10 m/sec, the helicopter should be turned against the wind and separation performed in this direction, then turned in the required direction while hovering.

The takeoff distance for a vertical takeoff in the zone of influence of the air cushion produced by test flight at a heliport 500 m above sea level with a flying weight of the helicopter of 40 T, air temperature 19°C and head wind 2-3 m/sec was 385 m. The length of the horizontal sector of acceleration on the air cushion was about 120 m. The flying distance with vertical takeoff depends on the same factors as with an airplane

type takeoff. Furthermore, the flying distance depends on the rate of climb established after the acceleration in the horizontal sector to 50-60 km/hr; the greater the rate of climb, the greater the flying distance. Figure 58 shows this dependence, produced by flying tests. The data are not corrected to standard atmospheric conditions. The tests were performed at an external air temperature of 22°C , $P_{\text{II}} = 742 \text{ mm Hg}$, head wind speed 2-3 m/sec. The power in the horizontal sector was increased to the nominal. The flying weight of the helicopter was 38.5 T. As we can see from the figure, with climbing rates of 90 and 100 km/hr at 25 m altitude, the flying distances are 416 and 442 m respectively. In using the Mi-6 helicopter, it is recommended that these speeds be reached at an altitude of 25 m. If the acceleration is performed less energetically and if the speed at 25 m altitude is less than 90-100 km/hr, the flying distance decreases correspondingly. As we can see, the flying distance is so great that vertical takeoff using the air cushion is possible only from type 1 heliports.

NOT REPRODUCIBLE

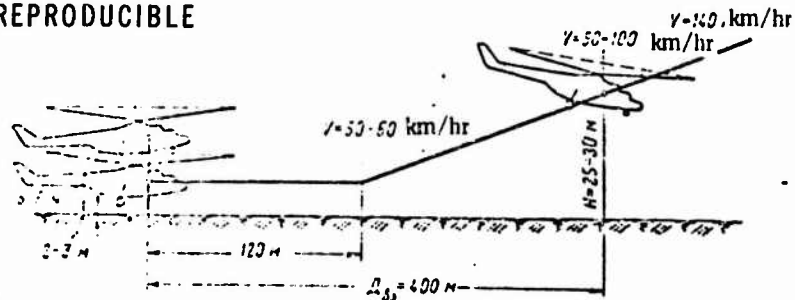

Figure 57. Profile and Elements of Vertical Takeoff Using Air Cushion.

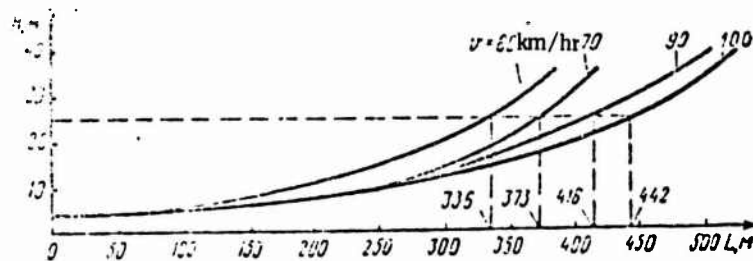

Figure 58. Flying Distance with Vertical Takeoff of Mi-6 Helicopter as a Function of Climbing Speed at Altitude 25 m: $G_{\text{av}} = 38,500 \text{ kg}$; UPRT reading--85%; $n_{1r} = 83\%$; $W = 2-3 \text{ m/sec}$ (head wind); $t = 22^{\circ}\text{C}$; $P_{\text{H}} = 742 \text{ mm Hg}$.

Vertical takeoffs from dusty or sandy heliports with head winds of over 5 m/sec represent no difficulties, since visibility is good. With a wind of less than 5 m/sec, dusty or sandy heliports should be sprayed with water before a vertical takeoff is made, since otherwise takeoffs are forbidden. Vertical takeoffs from heliports with freshly fallen or loose snow are forbidden. Vertical takeoff using the air cushion are allowed on heliports covered with snow, but hovering is performed with the nose of the helicopter into the wind at an altitude of 5 m, and the acceleration run is also begun at this altitude.

Brief description of takeoff method. After receiving permission for takeoff, the gas corrector knob is turned to the far right position, then the pilot waits until the rotating speed reaches 78-82%, lifts the helicopter off the surface by smoothly moving the general pitch lever upward, climbs to the height of the test hover (determined from the nomogram). If the helicopter hovers stably at this altitude at takeoff mode or less, takeoff is permitted. Then the pilot descends to 2-3 m, holding the rotating speed of the lifting rotor at 80-82%. He then smoothly moves the cyclical pitch lever to begin the acceleration run, at the same time increasing the engine power to the takeoff regime (97-100% according to the UPRT-2, general pitch 9°). The pilot accelerates to 50-60 km/hr without climbing or while climbing, but in either case flying so that the altitude will be 25-30 m when a speed of 90-100 km/hr is reached (as during the airplane type takeoff). After passing the obstacles, the speed is increased to 140 km/hr and the nominal engine operating mode is set (84-85° according to the UPRT-2), retaining the rotating speed of the lifting rotor at $79 \pm 2\%$ for a rotor with rectangular blades or $82 \pm 1\%$ for a rotor with trapezoidal blades.

NOT REPRODUCIBLE

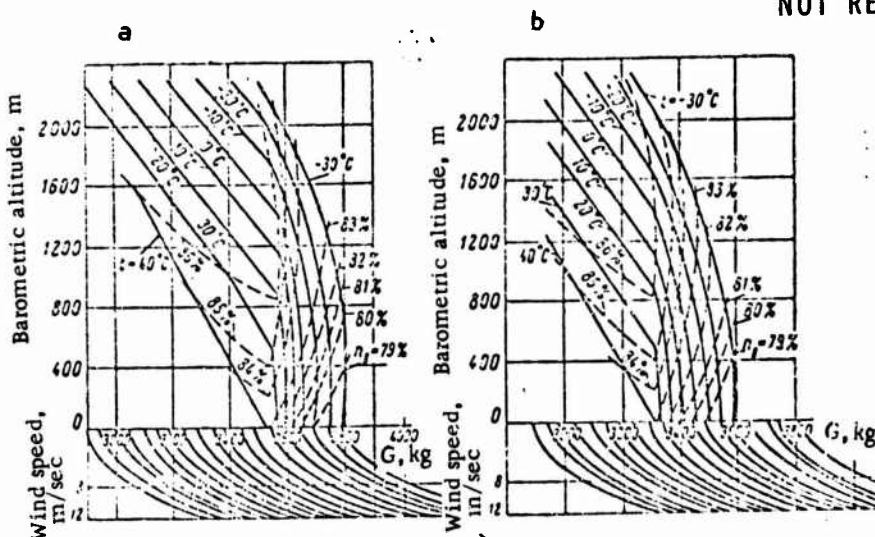

Figure 59. Nomograms for Determination of Limiting Flying Weight of Mi-6 Helicopter for Takeoff and Landing Without Using Influence of the "Air Cushion": a, For helicopter with rectangular blades; b, For helicopter with trapezoidal blades.

Vertical takeoff outside the zone of influence of the air cushion is performed during takeoff from type 2 heliports, for rescue, construction and installation work and during transport of externally suspended cargo.

In order to insure safe takeoff, the hovering altitude should be 10 m higher than any obstacles which must be overcome during the acceleration. In order that the helicopter might be able to climb to this altitude, it must be correspondingly unloaded. The maximum permissible takeoff weight in this case is determined from a nomogram, without considering the influence of the air cushion (Figure 59). The method of determining the maximum permissible takeoff weight and rotating speed of the lifting rotor in order to maintain a right pedal control reserve of 20 mm is the same as for the nomograms considering the influence of the air cushion. The control reserve of the right pedal is not changed, since the altitude at which the acceleration is begun is the same with this takeoff method as the altitude of the hover.

The higher the altitude of the heliport above sea level and the higher the air temperature, the higher must be the rotating speed of the lifting rotor in order to maintain a constant control reserve of the right pedal of 20 mm. This rule was used in constructing the curves of temperatures and lifting rotor speeds on the nomograms. The maximum permissible speed of the lifting rotor for a vertical takeoff is 86%. At those altitudes and temperatures for which the rotating speed should be over 86% in order to retain the control reserve of the right pedal at 20 mm, the rotating speed must be left as before, and the takeoff power decreased by decreasing the flying weight of the helicopter. This is also reflected in the nomograms. The solid curves showing the dependence of rotor thrust on altitude and various temperatures have a brake at points of intersection with the dotted line corresponding to 86% rotating speed of the lifting rotor. At altitudes greater than the altitude corresponding to these brake points, the curves are sloped sharply to the left, i.e., toward decreasing thrust (flying weight). Consequently, with less weight, less thrust and power are required, and the takeoff is performed at powers of less than takeoff power, assuring a right pedal travel reserve of at least 20 mm.

The correctness of the calculation of flying weight from the nomograms and the correctness of loading are determined before the takeoff: if the helicopter hovers stably at an altitude 10 m higher than local obstacles with the engine in the takeoff mode, the flying weight has been properly selected. Vertical takeoff outside the zone of influence of the air cushion consists of the following stages: vertical separation and climb to 10 m higher than local obstacles, brief hovering at this height, acceleration to the economical speed (140 km/hr) and the transition to a stable climb at this speed (Figure 60).

The vertical climb is performed carefully at low speed to a height 10 m above local obstacles. If this climb is performed too rapidly, the helicopter may continue to climb due to inertia to an altitude higher than its hovering ceiling for the given conditions, after which it will

begin to descend involuntarily. Also, the lifting rotor may be overweighted in this case. Acceleration after hovering is performed carefully, by smoothly deflecting the cyclical pitch lever forward, either horizontally or with some slight climb, depending on the power reserve. If there is no power reserve, that is if hovering is performed with the engines in the takeoff mode, the acceleration must be horizontal. As the obstacles are approached, the helicopter will have accumulated some speed, so that an excess in power will be available, allowing maneuvering. Collisions with obstacles will never occur if the heliport or area from which the takeoff is performed corresponds to the technical requirements for type 2 heliport.

With this type of takeoff, the vertical climb and acceleration are performed in the danger zone in case of engine failure; therefore, this type of takeoff is used only when necessary, but since the D-25V engine operate reliably, these takeoffs are widely used.

When taking off from sandy, dusty or snow covered heliports, the same recommendations should be followed as for the vertical takeoff using the air cushion, although in this case the conditions for this type of takeoff are more favorable, since the helicopter will move out of the zone of the dust cloud as it climbs vertically.

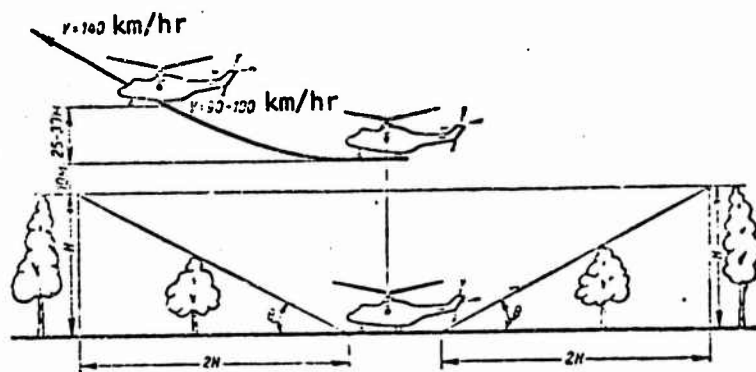

Figure 60. Profile and Elements of Vertical Takeoff Outside of Zone of Influence of Air Cushion.

Takeoffs with cargoes suspended externally are more difficult for the pilot and require higher power reserves; therefore, these takeoffs are permitted from heliports not over 500 m above sea level. The flying weight of the helicopter should not be over 38 T, the weight of the cargo suspended externally should not be over 8 T. After the cargo is hooked up, a test hover should be performed (height from cargo to ground 3 m), to check sintering and power reserve, and only after this should the acceleration be begun. Acceleration should be performed by deflecting the cyclical pitch lever smoothly forward, with constant increase in altitude.

When an indicated speed of 100 km/hr is reached, the engine should be shifted to the nominal operating mode, setting the rotating speed of the lifting rotor at 83%, and the helicopter should be transferred to the stable climbing mode.

Flying Limitations During Takeoff

1. The maximum permissible takeoff weight of the Mi-6 helicopter is 42,500 kg, the normal takeoff weight is 40,500 kg, the maximum permissible takeoff weight with externally suspended cargo is 38,000 kg.

2. The maximum permissible weight of transported cargo inside the cabin is 12,000 kg, on the external suspension system--8,000 kg (based on the strength conditions of the fuselage at the point of attachment of the hydraulic clamp line).

3. Takeoff can be performed with head winds of up to 25 m/sec, side winds up to 10 m/sec and tail winds of up to 5 m/sec. The weather minimum for all takeoffs during the daytime is: ceiling at least 200 m, horizontal visibility at least 2,000 m and wind speed not over 25 m/sec, air temperature from 40° to 50°C.

4. With a head wind of less than 5 m/sec, takeoffs from dusty or sandy heliports must be performed only using the aircraft type takeoff, with the following separation speeds: if the length of the surface suitable for the takeoff run is over 300 m, separation is performed at 50-60 km/hr; if the length of the area is less than 300, but not less than 100 m with open approaches, the separation speed is 30-35 km/hr.

5. Vertical takeoffs from heliports and areas with freshly fallen and loose snow are forbidden.

6. Takeoffs can be performed only from airports, permanent or temporary heliports or areas corresponding to the technical requirements for helicopter aviation heliports.

§19. Climbing with Forward Movement

General Characteristics

The basic form of climbing used by the Mi-6 helicopter is the climb with forward movement. This regime requires less power than a vertical climb, i.e., it is more economical. It is characterized by high rate of climb, as a result of the great excess power, improved stability and controllability and high control reserve; therefore, piloting techniques are made easier. Higher altitudes can be reached by climbing with forward movement (the ceiling of the helicopter is higher) than in a vertical climb (hovering ceiling), and this difference in altitudes is quite great.

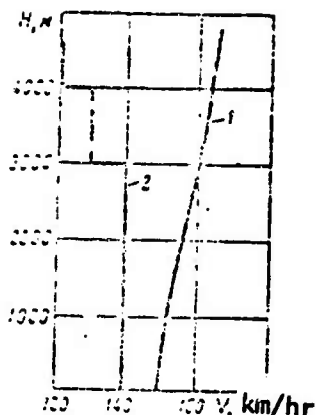

Figure 61. Change in Optical Climbing Speed as a Function of Flying Altitude: 1, Design (true); 2, Indicated.

The optimal speed for climbing is the economical horizontal flight speed (140 km/hr indicated), since at this speed the maximum excess power and therefore maximum rate of climb are achieved. The greatest true climbing speed, calculated as a function of flying altitude, changes as follows (Figure 61,1): at the surface it is 150 km/hr, it increases with increasing altitude and reaches 162 km/hr at 5,000 m.

The optimal indicated climbing speed is 140 km/hr up to 3,000 m, and should decrease by 10 km/hr per each 1,000 m altitude with further climbing (Figure 61,2).

The theoretical ceiling of the Mi-6 helicopter is 5,000 m, the practical ceiling is 4,500 m, the maximum permissible flying altitude for the helicopter at normal flying weight for the rotor with trapezoidal or rectangular blades. With a maximum weight of 42,500 kg, the maximum flying altitude is 3,000 m (rectangular blades) or 1,500 m (trapezoidal blades).

Climbing with forward speed requires more power than horizontal flight, so that climbing can be achieved only when there is excess power available

$$N_{cl} = N_{hf} + \Delta N.$$

The recommended and permissible rotating speeds of the lifting rotor for climbing and for all other flying modes are the same, shown in Table 6.

During a climb with the general pitch lever and gas corrector in the same position, the rotating speed of the lifting rotor will increase, since the fixed power is retained to an altitude of 3,000 m (while the

air density decreases and blade lightens). One task of the pilot during a climb is to observe the rotating speed of the lifting rotor and maintain it within the recommended limits, or in the extreme case at the permissible limit, to increase the weight of the lifting rotor using the general pitch lever and gas corrector.

TABLE 6. PERMISSIBLE AND RECOMMENDED ROTATING SPEEDS OF LIFTING ROTOR OF MI-6 HELICOPTER IN THE CLIMBING MODE

Altitude, m	Permissible Rotating Speed, %		Recommended Rotating Speed, %	
	Trapezoidal Blade	Rectangu- lar Blade	Trapezoidal Blade	Rectangular Blade
0	78-87	78-87	83	80
1000	78-87	78-87	83	80
2000	80-87	80-87	83	82
3000	82-87	82-87	83	83
4000	83-87	84-87	85	83
4500	84-87	85-87	86	86

Forces and Moments Acting on the Helicopter During a Climb with Forward Movement

When climbing with forward movement, the following forces and moments act on the helicopter (Figure 62): the total aerodynamic force of the lifting rotor R , the total aerodynamic drag of the wing R_w , the thrust of the tail rotor, the drag of the helicopter X , the weight of the helicopter G , the reactive moment of the lifting rotor M_p , the longitudinal, transverse and track moments of the tail rotor, the longitudinal and transverse moments of the lifting rotor hub, the longitudinal moments of the aerodynamic force of the lifting rotor, wing, stabilizer and the transverse moment of the side force S .

During a climb with forward movement, the cone of rotation and aerodynamic force of the rotor are deflected in the direction of flight using the cyclical pitch lever in the longitudinal direction. The aerodynamic force of the lifting rotor is split in the helicopters system of coordinates into three components: thrust T , longitudinal force H and side force S . The thrust is directed along the axis of the shaft, the longitudinal force--along the plane of rotation in the direction opposite to the direction of flight, the side force--in the plane of rotation to the right.

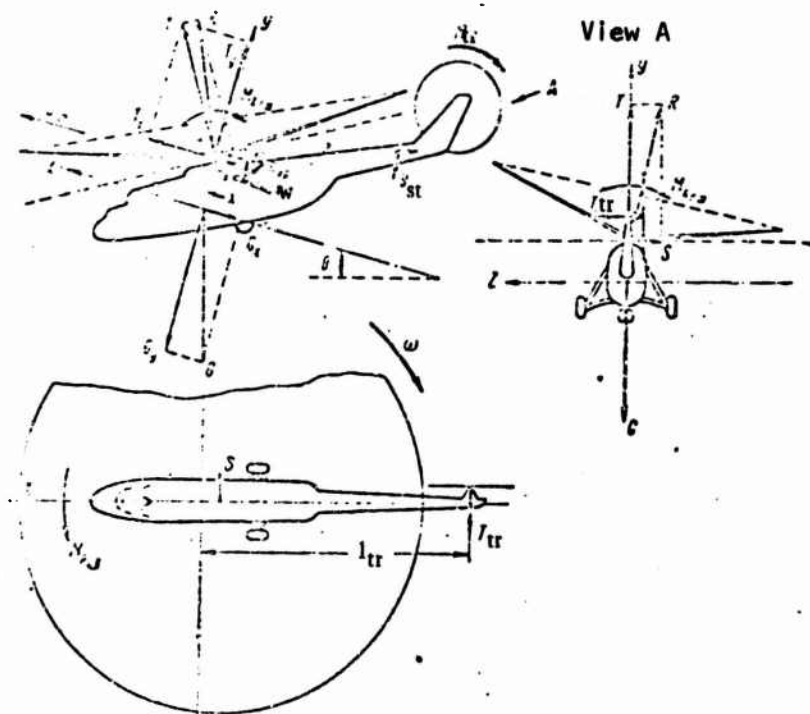

Figure 62. Diagram of Forces and Moments Acting on Helicopter During Climb with Forward Movement (Bank and Slip Not Shown).

The thrust of the rotor T can be separated in the velocity (flow) system of coordinates using the parallelogram of forces into force T_y , directed perpendicular to the flight trajectory, and force T_x --in the direction of flight. Force T_y is the lifting force, while T_x is the pulling force. Longitudinal force H can be separated into H_x , directed along the trajectory of flight but in the opposite direction, and H_y , directed in the direction of T_y . Force H_x is the drag of the lifting rotor, while H_y is the additional lifting force.

The aerodynamic force of the wind is separated into lift Y_w and drag X_w .

The thrust of the tail rotor is directed to the right. The drag of the helicopter arises as the main and induced flows move around the fuselage and is directed opposite to the direction of flight.

The force of the weight of the helicopter is separated into G_x , directed opposite to the direction of flight, and G_y , directed perpendicular to the flight trajectory downward.

In the mode of stable climb with forward motion, the following conditions of balance of forces should be observed. For linear climb with constant climb angle θ and vertical speed, it is necessary that the forces T_y , H_y and Y_w balance the weight component G_y

$$T_y + H_y + Y_w = G_y.$$

For even flight it is necessary that the pull T_x balance the component of longitudinal force H_x , drag of the helicopter X , drag of the wing X_w and weight component G_x

$$T_x = H_x + X + X_w + G_x.$$

In order to assure longitudinal equilibrium, the sum of all longitudinal moments should be equal to zero.

In the lateral direction, the helicopter can be balanced in this flying mode either with a right bank without slipping or with no bank but with left slipping.

Then when flying with a bank, the thrust of the tail rotor is balanced by side force S and weight component G_z , while when flying with left slipping, it is balanced by side component S of the lifting rotor and the lateral force of the fuselage Q_z .

In flight, the pilot achieves a stable climb with forward motion and balances the helicopter using the indications of the instruments and the position of the helicopter relative to the natural horizon.

Flying Characteristics of the Helicopter in the Regime with Climb with Forward Movement

The vertical speed of a climb with forward movement is determined using the following formula

$$V_y = \frac{\Delta N T_3}{G}.$$

According to this formula, the maximum vertical speed of climb should be achieved at the flight speed where the excess power is maximal (for the Mi-6 helicopter this is 140-150 km/hr). For horizontal flight, this is the most economical speed and for climbing it is the optimal speed. When the speed is changed from the optimal speed in the direction of lower forward speeds or higher excess powers, the vertical speed will be less. This theoretical statement is confirmed by flying practice. Figure 63 shows the curves of change in vertical climbing speed as

functions of flight speed on trajectories produced by flying tests for three flying weights at various air temperatures at the nominal engine operating mode at 500 m altitude. As we can see from the curves, the higher the flying weight, the less the vertical climbing speed, but in all cases it is maximal at 140 km/hr. The air temperature also influences the absolute vertical speed, although the nominal power does not change at up to 3,000 m, whereas the power required for horizontal flight increases with increasing temperature, so that the excess power decreases and, consequently, the vertical climbing rate decreases. The results of flying tests shown on Figure 63 were produced for a helicopter carrying its cargo within the cabin.

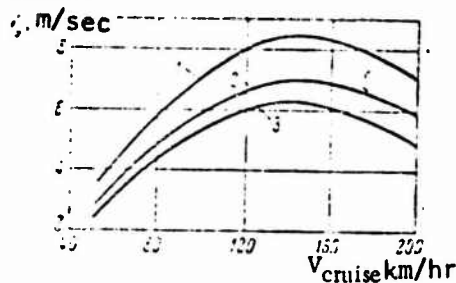

Figure 63. Vertical Rate of Climb as a Function of Flying Speed and Weight of Mi-6 Helicopter at Nominal Engine Operating Mode and 500 m Altitude: 1, $G = 35.6 T$, $t = 22^{\circ}C$; 2, $G = 38 T$, $t = 18^{\circ}C$; 3, $G = 38.4 T$; $t = 27^{\circ}C$.

Figure 64 shows the curve of change of vertical climbing speed as a function of flight speed along the trajectory (altitude 450 m, flying weight 37 T, nominal operating regime of engines, weight of cargo on external line 3 T, air temperature $10^{\circ}C$). As we can see from the curve, the maximum climbing speed is an indicated speed of 140-150 km/hr. Consequently, the optimal speed for climbing with cargo suspended externally remains practically the same as that with cargoes inside the cabin. Flying tests were also performed to determine the optimal climbing speed with externally suspended fuel tanks. It was established by these tests that the optimal climbing speed remains unchanged (140 km/hr). However, the vertical climbing speeds achieved with cargoes suspended externally will be less with all other conditions being equal than with cargo inside the cabin, due to the higher drag and consequently lower excess power.

The vertical rate of climb changes essentially as a function of flying altitude, since the excess power also changes.

Figure 65 shows curves of the change of maximum vertical rate of climb for the Mi-6 helicopter produced for climbs at the nominal operating mode of the engine and optimal climbing speed for a flying weight

of 38,800 kg under standard atmospheric conditions. Curve 1 shows the change in maximum vertical climbing speed with altitude produced by aerodynamic calculation. As we can see from the curve, the maximum vertical climbing speed at the earth is 6.5 m/sec, which decreases smoothly with increasing altitude, reaching 0.5 m/sec at 4,500 m (practical ceiling). Curve 2 shows the change in maximum vertical speed under the same conditions for a rotor with trapezoidal blades. In this case, the vertical speed is 6 m/sec at the surface, which is retained to a height of slightly over 1,500 m. This is explained by the increased engine power up to this altitude, so that even though the required power for flight increases, the available power increases as well, so that the excess power remains unchanged, and the vertical speed remains unchanged as well. With further climb, the vertical speed decreases: up to 3,000 m altitude, the excess power decreases due to the increase in required power, and at altitudes over 3,000 m, it continues to decrease due to the decreasing available power as well. Curve 3 shows the change in vertical speed under the same conditions for the rotor with rectangular blades. As we can see from this curve, the nature of the change of the rate of climb is almost the same as for the rotor with trapezoidal blades, but the absolute rate of climb is higher, since the aerodynamic and thrust characteristics of the lifting rotor with rectangular blades are superior.

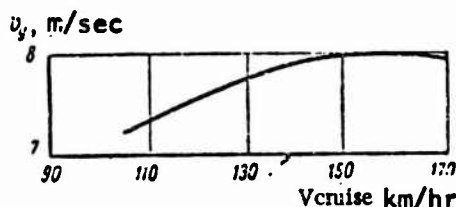

Figure 64. Vertical Rate of Climb as a Function of Flying Speed of Mi-6 Helicopter with Cargo Suspended Externally at Nominal Engine Operating Mode: $G = 37 T$, $H = 450$ m, $P = 760$ mm Hg, $t_{1r} = 10^{\circ}C$, $\eta_{1r} = 83\%$.

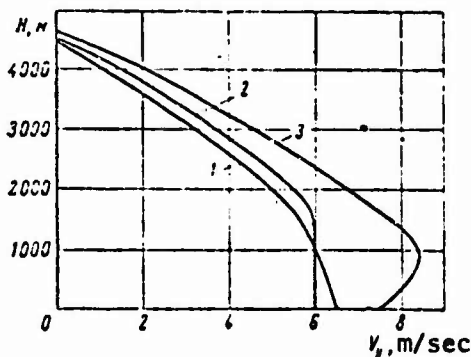

Figure 65. Maximum Vertical Rates of Climb of Mi-6 Helicopter at Flying Weight 38,800 kg at Nominal Engine Operating Mode Under Standard Atmospheric Conditions: 1, Calculated; 2, Established by flying tests of helicopter with trapezoidal blades; 3, Established by flying tests of helicopter with rectangular blades.

Figure 66 shows curves of time to altitude in the optimal climbing mode at the nominal engine operating mode for the Mi-6 helicopter with a flying weight of 38,800 kg under standard atmospheric conditions. Curve 1 shows the time produced by aerodynamic calculation, curve 2-- the time produced by flying tests of a helicopter with trapezoidal blades. As we can see from these curves, the calculated and experimental times almost correspond. Curve 3 shows the time to altitude for the same test conditions but for a rotor with rectangular blades. The time to altitude here is less due to the higher climbing speeds.

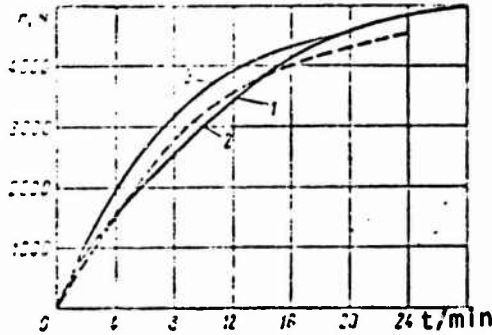

Figure 66. Time to Altitude for Mi-6 Helicopter at Optimal Mode (Nominal power, $G = 38,800$ kg).

The theoretical ceiling of the Mi-6 helicopter is 5,000 m; the practical ceiling is 4,500 m. As altitude is increased right up to 3,000 m (under standard atmospheric conditions), the rotating speed of the turbine compressor increases with the general pitch and gas corrector levers in the same position, since the air density decreases, leading to operation of the altitude-speed adjusting aneroid barometer and adjustment of the NR-23A regulator to a higher rotating speed. The power of the engines remains as set. As this occurs, the rotating speed of the lifting rotor increases independently, in order to retain the aerodynamic forces on the rotor.

At over 3,000 m altitude, the rotating speed of the turbine compressor and the power of the engine decrease with unchanged position of the "pitch-gas" lever. The rotating speed of the lifting rotor will remain the same or change slightly, either increasing or decreasing depending on conditions. During a climb, the pilot observes the rotating speed of the lifting rotor and holds it within the recommended or permissible limits, by moving the general pitch lever and the gas corrector (see Table 6).

Specifics of the Climb with Forward Speed and Methods of Performing it

The position of the control levers in a stable climbing mode differs from their position in horizontal flight at the same speed: the right pedal is moved forward from its position in horizontal flight (increasing thrust of tail rotor), the cyclical pitch lever is deflected to the right from its position occupied in horizontal flight (increasing side force).

In a stable climb without slipping, the helicopter will be balanced with a slight right bank (at $V = 140$ km/hr, the bank angle is 1.5°), as in horizontal flight due to the influence of the transverse moment of the hub, or with left slipping (at $V = 140$ km/hr, the slipping angle $\beta = 11^\circ$).

The pitch angle during a climb will depend on the rate of the climb, centering and operating mode of the engines: the higher the speed along the trajectory, the further forward the centering and the higher the operating regime of the engines, the less will be the pitch angle and vice versa. A climb is usually performed at the nominal engine operating mode at 140 km/hr up to 3,000 m altitude. After reaching this altitude, the helicopter is shifted into the horizontal flight mode, which is done without changing the operating mode of the engine by setting the required horizontal flight speed with the control lever, then selecting the engine operating mode for this speed using the general pitch lever and the gas corrector knob. When the helicopter is shifted from the climbing mode to the horizontal flight mode, the control levers must be moved smoothly in order to avoid imbalancing the helicopter and prevent the rotating speed of the lifting rotor from going beyond the permissible limit.

Climbing with externally suspended cargo is usually performed at a speed of 100 km/hr, particularly if the cargo is asymmetrical or very large. If the cargo is symmetrical in form and small in size, the helicopter will be stable at climbing speeds of 140-150 km/hr. The flying speed should be increased from 100 to 140-150 km/hr during a climb quite smoothly. Increases in speed must be stopped if the cable approaches close to the limiter ring or if the cargo begins to swing. After climbing to the required height, the helicopter should be put in the horizontal flight mode. Movement of the control lever should be quite smooth, in order to avoid imbalancing the helicopter and swinging the cargo.

Flying Limitations During Climbing with Forward Speed

1. The ceiling of the helicopter at normal flying weight is 4,500 m, with the maximum weight of the helicopter with trapezoidal blades--1,500 m, with rectangular blades--3,000 m.
2. The rotating speed of the lifting rotor should be maintained within the permissible and recommended limits (see Table 6). At heights up to

3,000 m, the maximum permissible rotating speed (87%) can be maintained for not over 5 min, at heights over 3,000 m--not over 60 min.

3. In helicopters with trapezoidal blades and the automatic swash plate mechanism, with maximum lead angle $6^{\circ}30'$, with full fuel tanks and with cargo centering near the limiting rearward position, in order to assure sufficient reserve of longitudinal control the speed should be not over 140 km/hr until 1,000 kg of fuel has been burned from tank group IV.

CHAPTER VI. HORIZONTAL FLIGHT

520. General Characteristics

Diagram of Forces and Moments Acting on Helicopter

During horizontal flight, the following forces and moments act on the helicopter (Figure 67): the aerodynamic force of the lifting rotor R , the aerodynamic force of the wing R_w , the thrust of the tail rotor T_{tr} , the drag of the helicopter X , the weight of the helicopter G , the reactive moment of the lifting rotor M_{rlr} , the track moment of the tail rotor M_{tr} , the longitudinal moment of the aerodynamic force of the rotor (diving), the longitudinal moments of wing and stabilizer, the longitudinal reactive moment of the tail rotor, the longitudinal moment of the hub M_{zh} , the transverse moment of the hub M_{xh} , the transverse moment of the tail rotor and the transverse moment of the side force S .

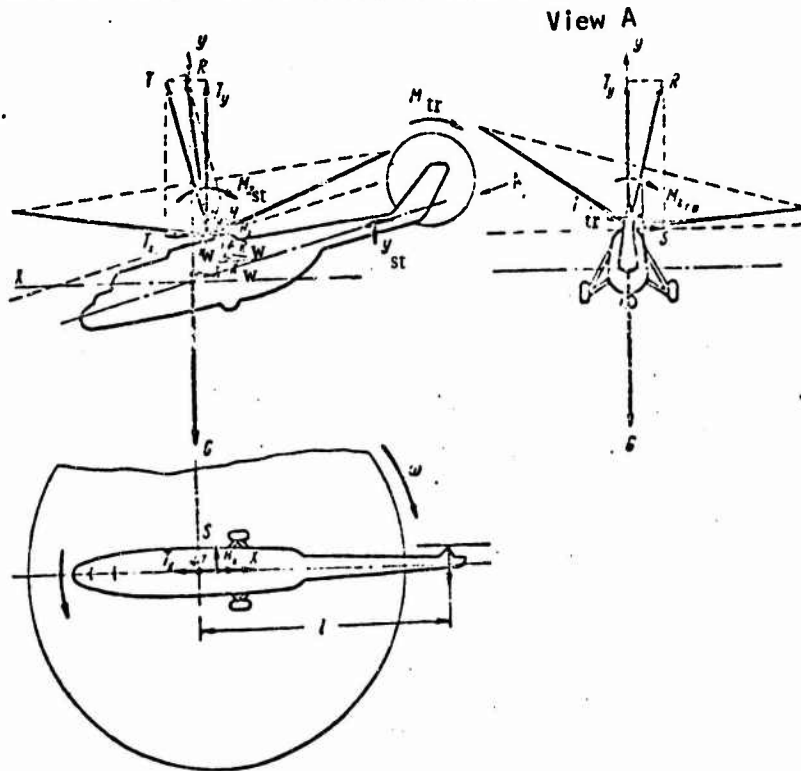

Figure 67. Diagrams of Forces and Moments Acting on Helicopter in Horizontal Flight.

In the coupled system of coordinates, the aerodynamic force of the lifting rotor can be separated into three components: rotor thrust T , longitudinal force H and lateral force S . In turn, thrust of the rotor T in the velocity (flow) system of coordinates can be separated into T_y --the vertical component and T_x --the horizontal component. Force T_y is the lifting force, force T_x is the pulling force. Force R_w is separated into the lift of the wing Y_w and the drag X_y , longitudinal force H --into H_y and H_x . The thrust of the tail rotor in horizontal flight is always directed to the left.

In stable horizontal flight at a fixed speed, the following conditions of equilibrium of forces should be maintained. It is necessary for straight and level flight that forces T_y , Y_w and H_y balance the weight of the helicopter G :

$$T_y + Y_w + H_y = G.$$

For even flight speed, it is necessary that force T_x be balanced by forces H_x , X and X_w :

$$T_x = H_x + X + X_w.$$

In horizontal flight, as during a climb, the helicopter is balanced either with a right bank or with left slipping. The bank or slipping forces will be less than during a climb due to the lower required power. The thrust of the tail rotor is balanced by the same forces as during a climb.

In flight, the pilot achieves stable horizontal flight and balancing and, therefore, observation of the equations, by using all control levers, depending on the indications of the instruments and the position of the helicopter relative to the natural horizon.

Required Power for Horizontal Flight

The required power for horizontal flight, depending on the flight speed, changes as follows: it is minimal at the economical speed, higher at higher and lower speeds, since the lifting rotor operates under poorer conditions at these speeds, and more power is required to maintain the necessary thrust for horizontal flight at these speeds. With increasing altitude, the required power for all indicated speeds increases.

Let us examine the required power for horizontal flight of the Mi-6 helicopter as a function of position of the fuel feed lever (UPRT) and

the general pitch of the lifting rotor. These characteristics are most expedient from the standpoint of flying techniques. Figure 68 shows curves for the Mi-6 helicopter with rectangular blades at various rotating speeds of the lifting rotor with a flying weight of 40 T at 1,000 m altitude under standard atmospheric conditions. The pitch-gas system allows flight to be performed at various rotating speeds of the lifting rotor within the limits permissible for the given flying mode. We can see from Figure 68 that the minimal pitch and minimum value of UPRT will occur at a true speed of about 170 km/hr, corresponding to an indicated speed of 140-150 km/hr. At other flight speeds, the required values of general pitch and UPRT indications will be higher. We can also see from the figure that the lower the rotating speed of the lifting rotor, the less will be the power according to the UPRT indication with the same speed, i.e., at lower rotating speeds less power is required, since the profile losses of the lifting rotor are decreased. However, a higher pitch of the lifting rotor is required to maintain the necessary thrust at lower rotating speeds, which in turn leads to an increase in required power as a result of increasing inductive losses of the lifting rotor. However, the increased inductive loss with higher pitch is less than its decrease due to profile power resulting from the lower rotating speed and, consequently, in this case less total power is required for horizontal flight. However, flight must not be performed at rotating speeds below the established permissible speeds, since this will result in a decrease in speed due to flow separation, increased vibration and decreased control reserve. Furthermore, the reserve of rotating speed and time for transition to autorotation in case of engine failure will be insufficient.

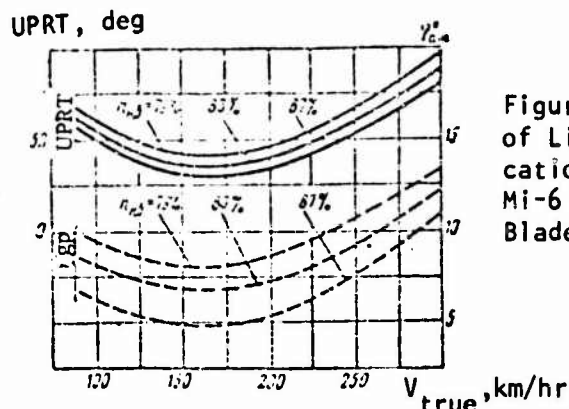

Figure 68. Required General Pitch of Lifting Rotor and UPRT-2 Indications for Horizontal Flight of Mi-6 Helicopter With Rectangular Blades.

The higher the rotating speed of the lifting rotor, the more power is required, so that it is also not expedient to fly at high lifting rotor speeds. Furthermore, with high lifting rotor speeds the flutter reserve is decreased, and the required power increases due to the increase in wave drag.

Therefore, a strictly defined range of permissible rotating speeds of the lifting rotor as a function of altitude has been established for

horizontal flight in the Mi-6 helicopter (see Table 6). Recommended speeds for the Mi-6 helicopter are presented in Table 7, regardless of weight.

TABLE 7. RECOMMENDED ROTATING SPEEDS OF LIFTING ROTOR FOR MI-6 HELICOPTER IN HORIZONTAL FLIGHT AT VARIOUS ALTITUDES

Altitude, m	Rotating Speed of Lifting Rotor, %		Altitude, m	Rotating Speed of Lifting Rotor, %	
	Trape- zoidal Blades	Rectan- gular Blades		Trape- zoidal Blades	Rectan- gular Blades
0	79±1	79±2	3000	83±1	83±2
1000	80±1	79±2	4000	84±1	84±2
2000	86±1	79±2	4500	85±1	85±2
3000	80±1	81±2			

§21. Characteristic Speeds for Horizontal Flight

Horizontal flight can be performed in the Mi-6 helicopter throughout the entire range of speeds. However, there are characteristic speeds used as a function of flying conditions, as well as limiting speeds. The Mi-6 helicopter has four characteristic speeds: the minimal, economical, optimal (cruising) and maximal.

Minimal Speed

The minimal speed of horizontal flight of the helicopter is that speed at which the helicopter can be retained in horizontal flight at a given altitude in the takeoff or nominal operating regime of the engines. The minimal speed of horizontal flight for any helicopter at altitudes from zero to the hovering ceiling is zero, while above the hovering ceiling it increases gradually to the economical speed at the flying ceiling of the helicopter. This change in minimal speed with altitude is explained by the change in required and available powers for horizontal flight as a function of altitude and speed. The required power for hovering and horizontal flight increase with increasing altitude, and decrease with increasing speed from zero to the economical speed. The available power remains the same with increasing altitude to the design altitude, then decreases with increasing altitude above the design altitude. Therefore, above the hovering ceiling, as altitude increases, the minimal speed of horizontal flight also increases. At the ceiling of the helicopter, the minimal speed will be equal to the economical speed, since the minimal power is required at this speed. This change in minimal speed with altitude is called the change with respect to engine power.

The minimal speed of horizontal flight can be produced by aerodynamic calculation and can be determined as a result of flying tests.

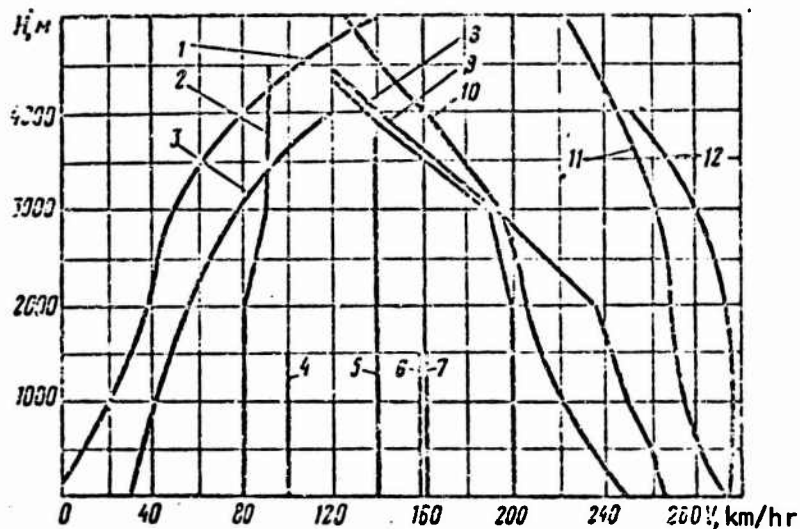

Figure 69. Change in Characteristic Speeds of Horizontal Flight as a Function of Altitude for Mi-6 Helicopter with Trapezoidal Blades Under Standard Atmospheric Conditions: 1, Minimal true speed in takeoff engine operating regime (theoretical); 2, Minimal true speed in nominal engine operating regime (theoretical); 3, Minimal indicated speed established in operation for helicopter with flying weight not over normal (40.5 T); 4, Minimal indicated speed for Mi-6 helicopter at maximum flying weight; 5, Economical speed, indicated; 6, Indicated cruising speed for helicopter with maximum weight; 7, Maximum permissible indicated speed at maximum helicopter weight; 8, Indicated cruising speed for helicopter with normal flying weight; 9, Maximum indicated speed, limited by chief designer and established in operation; 10, Maximum permissible true speed, theoretical; 11, Maximum possible true speed (theoretical); 12, Maximum true speed with respect to engine power, produced by aerodynamic calculation for nominal engine operating mode.

The minimal speed (true) for horizontal flight in the takeoff regime of engine operation for the Mi-6 helicopter at normal flying weight with trapezoidal blades, produced as a result of aerodynamic calculation, is shown by curve 1 on Figure 69. As we can see from this theoretical curve, the Mi-6 helicopter has no hovering ceiling in the takeoff regime, or it is extremely low. As the altitude increases, the minimal speed increases, and at 5,000 m it is 140 km/hr. The change in minimal speed with altitude

at the nominal operating regime of the engine is represented by curve 3. As we can see from the curve, at the ground the minimal speed is 30 km/hr, while the increasing altitude it increases (120 km/hr at 4,000 m).

However, the minimum speeds are limited in flying practice. Flying tests of an Mi-6 helicopter with trapezoidal blades and weight not over normal have established the following minimum permissible horizontal indicated flight speeds (curve 2):

Height, m	Speed, km/hr
0-2000.....	80
2000-3000.....	80-90
3000-4500.....	90

If the flying weight of the helicopter is over the normal or maximum permissible (42.5 T), the minimum indicated speed is 100 km/hr at altitudes from zero to 1,500 m, curve 4.

For the Mi-6 helicopter with rectangular blades and normal flying weight, the minimum permissible indicated speeds are limited to the following limits at altitudes (curve 1, Figure 70):

Height, m	Speed, km/hr
0-2000.....	80
2000-3000.....	80-110
3000-4500.....	110

The true minimal speed for this same helicopter is shown on curve 3, Figure 70.

For the helicopter with rectangular blades and maximum weight, the minimum indicated speed is 110 km/hr at all permissible altitudes up to 3,000 m.

As we can see from these data, the minimum indicated speeds established in operating the Mi-6 helicopter with rectangular blades is somewhat higher than the speeds for the helicopter with trapezoidal blades. Thus, whereas the Mi-6 with trapezoidal blades at normal flying weight at over 3,000 m altitude has a minimum permissible indicated speed of 90 km/hr, the minimum permissible speed for the helicopter with rectangular blades is 110 km/hr. In the helicopter with maximum weight and trapezoidal blades, the speed at all altitudes is 100 km/hr, or with rectangular blades--110 km/hr. This is explained by the fact that vibration is observed in the helicopter with rectangular blades at low speeds over a broader range of speeds than in the helicopter with trapezoidal blades.

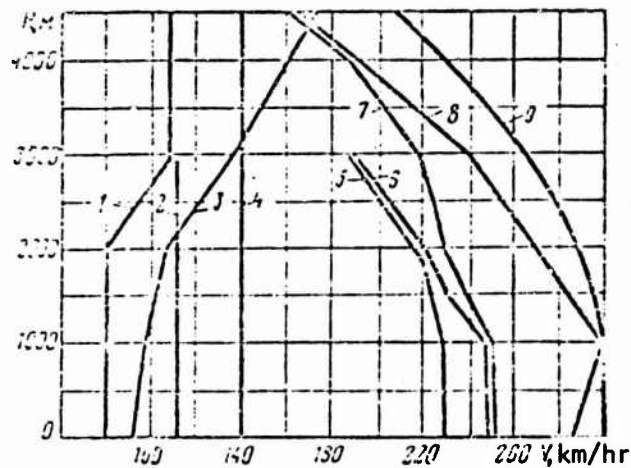

Figure 70. Changes in Characteristic Horizontal Flight Speed of Mi-6 Helicopter with Rectangular Blades: 1, Minimum indicated speed established for operation of Mi-6 helicopter at normal flying weight; 2, Minimum indicated speed for helicopter at maximum flying weight; 3, Minimum true speed established for operation of helicopter at normal flying weight; 4, Economical indicated speed; 5, Indicated cruising speed for helicopter with maximum flying weight; 6, Maximum permissible indicated speed for helicopter at maximum weight; 7, Indicated cruising speed for helicopter at normal flying weight; 8, Maximum permissible indicated speed for helicopter at normal flying weight; 9, Maximum permissible true speed for helicopter at normal flying weight.

Economical Speed

The economical speed of horizontal flight is the speed requiring the minimal power, and therefore the minimum hourly fuel expenditure. The helicopter will go further for a given reserve of fuel at the economical speed, and will expend the minimum quantity of fuel when flying over a fixed time. Calculation and flying tests have indicated that the minimum hourly fuel consumption of the Mi-6 helicopter is achieved at an indicated speed of 140-150 km/hr. Figure 71 shows curves of hourly fuel consumption as a function of flying speed, produced as a result of flight tests. Curve 1 shows the dependence of hourly fuel consumption on flying speed of the Mi-6 helicopter with trapezoidal blades with a flying weight of 39.7 T at 500 m altitude at an air temperature of 17°C. Curve 2 shows the similar dependence for a helicopter carrying 40 T with rectangular blades at an altitude of 500 m. As we can see from the curves, for the Mi-6 helicopter with trapezoidal blades the minimum hourly fuel consumption is

2,200 kg at an indicated speed of 140-150 km/hr, while the helicopter with rectangular blades consumes about 2,000 kg/hr at a slightly higher speed-- 150-160 km/hr.

As the weight of the helicopter and flying altitude are increased, the fuel consumption per hour increases, since the required power for flight increases. Therefore, the longest flight duration can be achieved at low altitudes. The hourly consumption of fuel and duration of flight also depend on the temperature and pressure of the air: the higher the temperature and lower the atmospheric pressure, the greater the hourly fuel consumption, and the briefer the duration of flight.

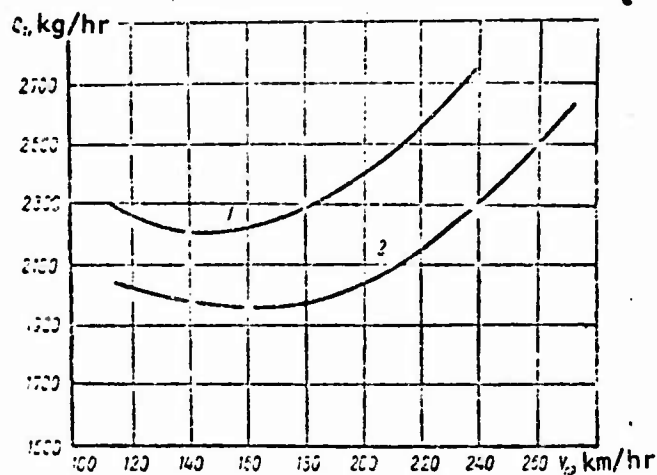

Figure 71. Hourly Fuel Consumption as a Function of Flight Speed.

The economical indicated speed is independent of flying altitude: for the Mi-6 helicopter, both with rectangular and with trapezoidal blades, it is taken as 140 km/hr (see Figure 69, 70).

With full main, suspended and supplementary fuel tanks (13,295 kg fuel) the maximum flight duration at the economical speed of 140 km/hr at 500 m altitude under standard atmospheric conditions is about six hours.

The economical speed is used for flights where long distances need not be covered, or for flights when the helicopter must remain aloft for various reasons. The economical speed of horizontal flight is the optimal climbing speed, since this speed provides the maximum excess power and consequently the maximum vertical speed.

Optimal and Cruising Speeds

If the optimal speed of horizontal flight is that speed at which the minimal fuel consumption per mile is achieved. Flying at this speed,

with a given fuel reserve, provides the maximum flying range, and the minimum quantity of fuel is consumed to cover a given distance.

The dependence of the fuel consumption per kilometer on indicated speed for the Mi-6 helicopter with trapezoidal and rectangular blades at 500 m altitude is shown on Figure 72. As we can see from the curves, the minimum fuel consumption per kilometer for the helicopter with trapezoidal blades is at an indicated speed of somewhat over 200 km/hr, while for the helicopter with rectangular blades it is at an indicated speed of around 250 km/hr. The curves also show that the consumption of fuel per kilometer is less in the helicopter with rectangular blades--9 kg/km as opposed to 11.5 kg/km for the helicopter with rectangular blades, in spite of the fact that the weight of this helicopter was somewhat greater in the tests used to make the graph.

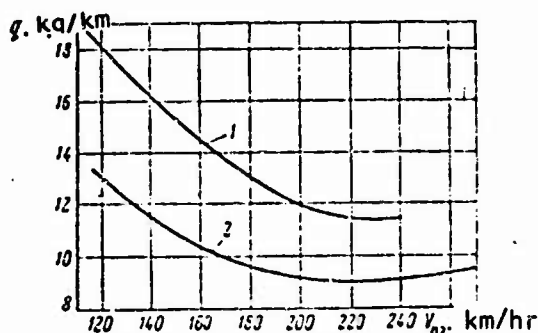

Figure 72. Fuel Consumption Per Kilometer as a Function of Flight Speed: 1, For helicopter with rectangular blades, flying weight 39.7 T, altitude 500 m at $t = 17^{\circ}\text{C}$; 2, Helicopter with rectangular blades, flying weight 40 T, altitude 500 m, standard atmospheric conditions.

For the helicopter with trapezoidal blades and normal flying weight at the surface, speed of 200 km/hr indicated is used for long flights, while a speed of 250 km/hr indicated (cruising speed) is used for the helicopter with rectangular blades.

The optimal true speed (speed at which the greatest flight range is attained) increases with increasing altitude, while the indicated speed remains the same. However, since the optimal speed of the Mi-6 helicopter is slightly less than the maximum permissible speed, which decreases with increasing altitude, the cruising speed is also decreased.

For an Mi-6 helicopter with trapezoidal blades with normal flying weight (40.5 T) the cruising speed is also less, set at the following limits (curve 8, see Figure 69):

Altitude, m	Speed, km/hr
0-2000.....	200
2000-3000.....	200-190
3000-4000.....	190-140
4000-4500.....	140-120

As we can see from curve 8, Figure 69, beginning at 2,000 m altitude the cruising speed decreases, since the maximum permissible speed decreases, and from 3,000 m altitude upward it is equal to the maximum permissible speed of horizontal flight. For the helicopter with flying weight up to 42.5 T, the indicated cruising speed is set regardless of altitude at 160 km/hr, i.e., it is equal to the maximum permissible indicated speed at heights up to 1,500 m (see curve 6, Figure 69).

For the Mi-6 helicopter with rectangular blades and normal flying weight or less, the indicated cruising speed changes with altitude as follows (curve 7, Figure 70):

Altitude, m	Speed, km/hr
0-1000.....	250
1000-1500.....	250-240
1500-2000.....	240-230
2000-2500.....	230-225
2500-3000.....	225-220
3000-4000.....	220-190
4000-4500.....	190-165

As we can see from Figure 70 (curves 7 and 8) the indicated cruising speed decreases with increasing altitude, since the maximum permissible indicated speed decreases.

For an Mi-6 helicopter with weight above the normal, the maximum indicated cruising speeds are set as follows (curve 5, Figure 70):

Altitude, m	Speed, km/hr
0-1000.....	230
1000-1500.....	230-225
1500-2000.....	225-220
2000-2500.....	220-200
2500-3000.....	200-190

This speed also decreases with increasing altitude due to the decreased maximum permissible speed at this flying weight at altitudes up to 3,000 m (curves 5 and 6, Figure 70).

The optimal speed is used for ordinary flights, both those to maximum range, and those over fixed ranges.

The consumption of fuel per kilometer and the flying range at cruising speed will depend on the weight of the helicopter, altitude of flight, speed and direction of wind. The greater the weight of the helicopter, the higher the consumption of fuel per kilometer due to the increase in required power, and the less the flying range. Up to 3,000 m altitude, the consumption of fuel per kilometer decreases, while the range increases, while at altitudes over 3,000 m the consumption of fuel per kilometer increases, and the range decreases significantly, so that flights should be performed at the altitude performance limit of the engine--3,000 m. Figure 73 shows curves of the change in fuel consumption per kilometer for the Mi-6 helicopter with trapezoidal blades at cruising speed as a function of helicopter weight and flying altitude. As we can see from the curves, the minimum fuel consumption per kilometer will be obtained at 3,000 m altitude, increasing at higher or lower altitudes. The crew uses this graph to determine the quantity of fuel for a given flight, taking the mean weight of the helicopter over the horizontal flight sector to be covered as the weight indicated in the graph. Since the Mi-6 helicopter flies at comparatively low speeds, the flying range is essentially influenced by the speed and direction of the wind.

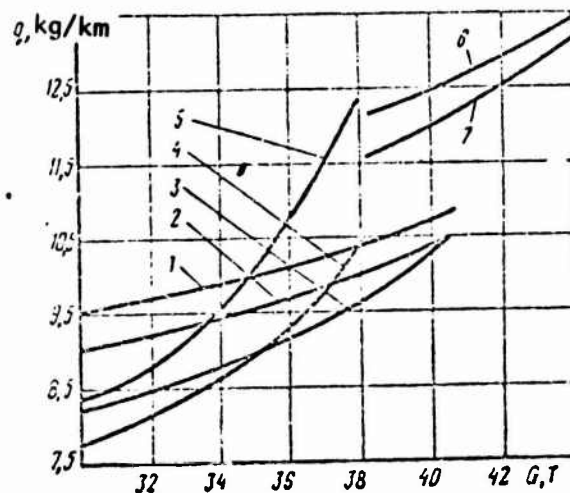

Figure 73. Consumption of Fuel per kilometer for Helicopter with Trapezoidal Blades Under Standard Atmospheric Conditions at Cruising Speed in Horizontal Flight as a Function of Flying Altitude and Helicopter Weight:

- 1 - $H=500$ m, V_{cruise} km/hr;
- 2 - $H=1000$ m, V_{cruise} km/hr;
- 3 - $H=2000$ m, V_{cruise} km/hr;
- 4 - $H=3000$ m, V_{cruise} km/hr;
- 5 - $H=4000$ m, V_{cruise} km/hr;
- 6 - $H=5000$ m, V_{cruise} km/hr;
- 7 - $H=10000$ m, V_{cruise} km/hr.

The flying range will also be influenced by such factors as the rotating speed of the lifting rotor and the placement of the cargo. The higher the speed of the lifting rotor, the higher the fuel consumption per kilometer and the less the range. Therefore, the rotating speed should always be kept within the recommended limits for given altitude for the helicopter with trapezoidal blades as well as for the helicopter with rectangular blades (see Table 7). Placement of cargo on the external support increases the fuel consumption and decreases flying range. If we consider that it is not always possible to maintain the maximum permissible flight speed (200 km/hr) with externally suspended cargo, we see that the fuel consumption is clearly increased and flight range clearly decreased when cargo is carried in this manner. Placement of suspended fuel tanks has practically no influence on the fuel consumption and flight range, so that all calculations for the helicopter with suspended tanks can be made using the same data as for the helicopter without them.

Figure 74 shows graphs of the dependence of flight range of the Mi-6 helicopter with trapezoidal blades at optimal flying mode for normal and maximal takeoff weight as a function of flying altitude and quantity of fuel carried. On Figure 74a, this dependence is given for the Mi-6 helicopter with normal flying weight in the optimal flying regime ($V_{pr} = 200$ km/hr, $n_{lr} = 83\%$). As we can see from the curves, the greater the fuel reserve, the greater the flying range, and when 12,000 kg of fuel are carried, when flying at 500 m the maximum range is 1050 km, at 1,000 m--1075 km, at 2,000 m--1175 km. When flying at 3,000 m, the range is about 1200 km, at 4,000 m--about 1100 km (Figure 74b). Figure 74c shows the dependence of range on quantity of fuel in all tanks (13,295 kg) for the maximum helicopter weight of 42.5 T. In this case, when flying at 500 m the maximum range is 1125 km, at 1,000 m--1175 km).

With the maximum permissible takeoff weight of the helicopter with trapezoidal blades, the optimal indicated speed of 160 km/hr is maintained over the first portion of the trip. As the fuel is consumed, the weight of the helicopter decreases, so that in the second portion of the trip, when the weight is 40.5 T or less, the speed should be 200 km/hr. This change in flying regime is used for the Mi-6 helicopter with rectangular blades as well, except that the corresponding speeds are higher: 230 and 250 km/hr.

The graphs of Figure 74 were constructed according to the results of flying tests. The crew uses these graphs to determine the quantity of fuel required as a function of planned flight range. They consider the quantity of fuel required for operation of the engines on the ground for 5 min (120 kg), fuel consumption in climbing to the required altitude and descending from the altitude, with an unexpended fuel reserve of 50 kg in the main tanks and 20 kg in the suspended and supplementary tanks, a navigation reserve of 0.5 hr flight--1200 kg. The fuel reserve for climbing and descent is determined using a separate graph and table, presented in the handbook on flying operations of the Mi-6 helicopter.

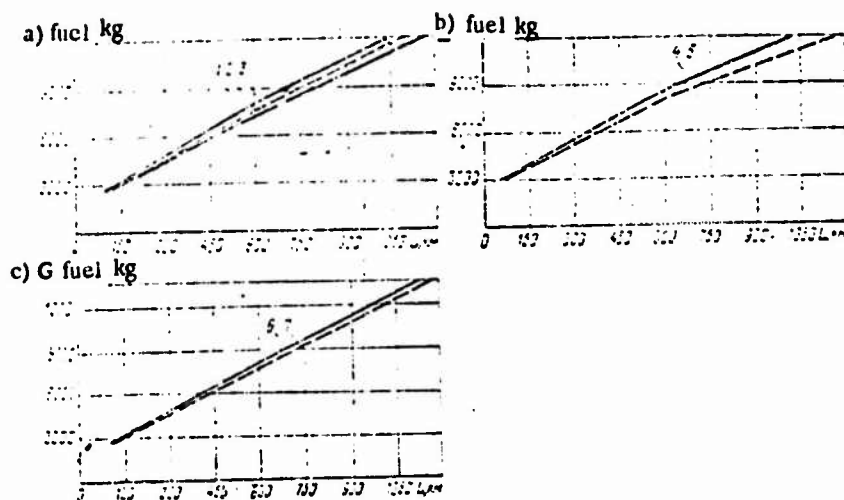

Figure 74. Range of Flight of Helicopter as a Function of Quantity of Fuel Carried: a, $G_{to} = 40.5 T$; b, $G_{to} = 40.5 T$; c, $G_{to} = 42.5 T$; 1, 2, 3, $H = 500; 1000, 2000$ m; $V_{pr} = 200$ km/hr; 4, $H = 4000$ m, $V_{pr} = 145$ km/hr; 5, $H = 3000$ m, $V_{pr} = 190$ km/hr; 6, $H = 500$ m, $V_{pr} = 160$ and 200 km/hr; 7, $H = 1000$ m, $V_{pr} = 160$ and 200 km/hr.

The flight range of the Mi-6 helicopter with rectangular blades is higher than the flight range of the helicopter with trapezoidal blades as a result of the lower consumption of fuel per kilometer and the higher permissible flight speeds both for the normal flying weight and for the maximum permissible weight at all altitudes, allowing the optimal (cruising) speed to be used over a broader range than for the helicopter with trapezoidal blades (see Figures 69 and 70).

Maximum Speed

The Mi-6 helicopter has three maximum speeds: maximum speed according to engine power, according to flow separation and maximum speed limited by the chief designer and used for operation of the helicopter.

The maximum speed according to engine power. The maximum horizontal flight speed of the helicopter is determined from the following formula:

$$V_{max} = 270 \frac{N}{G} \cdot \frac{C_y}{C_x} \tau_{out}$$

where N/g is the power to weight ratio of the helicopter;
 C_y/C_x is the aerodynamic quality of the helicopter;
 η_0 is the relative efficiency of the lifting rotor;
 ξ is the engine power usage factor.

As we can see from the formula, the maximum horizontal flight speed is directly proportional to the power to weight ratio, aerodynamic quality, relative efficiency coefficient of the lifting rotor and power usage factor. Depending on the altitude, with otherwise equivalent conditions, this speed changes in proportion to the change in engine power at the nominal operating mode (see Figure 38). The maximum horizontal flight speeds with respect to power, depending on altitude, can be produced by aerodynamic calculation (see Figure 48). The maximum speeds for the Mi-6 helicopter with trapezoidal blades, produced by aerodynamic calculation, for the nominal engine operating mode change as follows with changing altitude (see curve 12, Figure 69):

Height, m	Speed, km/hr
0.....	294
1000.....	295
3000.....	280
4000.....	252

The helicopter cannot be operated at these speeds, due to limitations placed by the strength of the lifting rotor and due to limitations resulting from flow separation at the blade tips.

Maximum speed with respect to flow separation. This speed in horizontal flight was determined by aerodynamic calculation for two cases: at azimuth 270° with the maximum blade angle of attack (12°) corresponding to the critical angle of attack of the blade element, and at an angle greater than the critical angle-- 15° . The critical speeds with respect to flow separation, corresponding to the maximum angle of attack are equal to the critical speeds, called the maximum permissible speeds. They change as follows with altitude for the Mi-6 helicopter with trapezoidal blades (see curve 10, Figure 69):

Height, m	Speed, km/hr
0.....	252
1000.....	217
3000.....	194
4000.....	156
5000.....	125.6

The maximum permissible speed with respect to flow separation are higher than the maximum permissible speeds and will change with altitude as follows (see curve 11, Figure 69).

Height, m	Speed, km/hr
0.....	296
1000.....	272.6
3000.....	268
4000.....	242
5000.....	223

The maximum speed used for operation of the Mi-6 helicopter. For a helicopter with normal flying weight using trapezoidal blades, the maximum indicated speeds established for operation change as follows with changing altitude (see curve 9, Figure 69):

Height, m	Speed, km/hr
50.....	265
500.....	260
1000.....	250
2000.....	235
3000.....	190
4000.....	140
4500.....	120

For the helicopter with trapezoidal blades and the maximum takeoff weight (42.5 T), the maximum permissible indicated speed at all permissible altitudes is 160 km/hr (see curve 7, Figure 69).

For the Mi-6 helicopter with rectangular blades and normal flying weight, the maximum permissible indicated speeds in horizontal flight, depending on altitude, have been established as follows (see curves 8 and 9, Figure 70):

Height, m	Speed, km/hr
50.....	300
500.....	300
1000.....	300
2000.....	270
3000.....	240
4000.....	190
4500.....	165

For the Mi-6 helicopter with rectangular blades and flying weight between normal and maximal, the following maximum permissible indicated speeds have been established (see curve 6, Figure 70):

Height, m	Speed, km/hr
500.....	250
1000.....	250
1500.....	230
2000.....	220
3000.....	190

§22. Specifics of Horizontal Flight and Methods of Performing it

The speed for horizontal flight is selected on the basis of the conditions and purpose of the flight: flight with the minimum fuel consumption per hour or per kilometer, flight on a schedule with minimum time expenditure, cargo placed inside the cargo cabin or supported externally. The required speed is maintained using the cyclical pitch lever, the required power for the given speed is set using the "pitch-gas" lever. The rotating speed of the lifting rotor should correspond to the recommended or permissible speed for the given speed and altitude (see Table 6 and 7), and the required speed and altitude are maintained by setting the proper engine operating mode, which the pilot sets using the general pitch lever, determining the mode by the indications of the UPRT and ITE-2. It should be recalled that when the general pitch lever is lowered the rotating speed of the lifting rotor will increase, while when it is raised--it will decrease, and that the gas corrector must be used to maintain the rotating speed within the permissible limits.

During flight, the position of the longitudinal trimmer indicator with no pressure applied to the cyclical pitch lever in the longitudinal direction must be used to observe the centering of the helicopter, since it may change as a result of failure of the automatic fuel tank sequencer. If the trimmer indicator lever is deflected by more than 1.5-2 divisions from the neutral position, the problem with the fuel sequencer must be corrected, or the flight engineer should go over to manual control of the fuel expenditure sequence.

The position of the control levers is the same as on the Mi-4 helicopter throughout the entire range of horizontal flight speeds: as the flight speed increases, the cyclical pitch lever should be moved forward and to the left, the left pedal should be applied up to a certain speed; with further increases in speed, the right pedal will be moved forward, since the conditions of operation of the tail rotor are poorer at high speeds and its pitch must be increased using the "pitch-gas" lever; throughout the entire range of speeds, the required power must be maintained (see Figure 68).

Turns are made in the Mi-6 helicopter in the same manner as in the Mi-4. If the flying weight of the helicopter is normal, the bank angle in a turn should not exceed 30°, or with maximum weight--15°. The

maximum bank is limited by overloading, and therefore by the strength reserve of the lifting rotor blades. The helicopter is put into a turn by coordinated movement of the cyclical pitch lever and the pedal in the direction of the required turn, with a simultaneous increase in power. Since less power is required to make a left turn than to make a right turn, at a bank up to 15° in a left turn the power need not be increased. Turns can be performed throughout the entire permissible range of flight speeds. During training flights, turns are made at 160 km/hr.

As a result of the thrust of the tail rotor and the flapping moment of both rotors, more power is required in a right turn for the Mi-6 helicopter, and there is a tendency to decrease speed and bank, which must be countered by corresponding movements of the cyclical pitch and general pitch levers. For these same reasons, less power is required to make a left turn than to make a right turn, and then there is a tendency on the part of the helicopter to increase its speed and bank, which must also be countered by the proper movement of the control levers.

The pilot should begin bringing the helicopter out of a turn 10-15° before the desired direction, as indicated by the gyroinduction compass. The helicopter is brought out of the turn by coordinated movement of the control levers. As the helicopter is put into a turn, the turn is performed and the helicopter is brought out of the turn, all control levers must be moved smoothly and in a coordinated manner, to avoid unbalancing the helicopter and make piloting easier.

The radius and time of one turning circle are determined using the same formulas as for an airplane (Table 8).

TABLE 8. RADIUS AND TIMES OF ONE TURNING CIRCLE AS A FUNCTION OF SPEED AND BANK ANGLE

Speed, km/hr	Bank, deg	Radius, m	Time, sec	Speed, km/hr	Bank, deg	Radius, m	Time, sec
160	10	1140	160	180	10	1450	180
	15	750	105		15	950	120
	30	350	50		30	440	55

Low altitude flights are performed when it is impossible to use taxiing (due to the condition of the surface), during special operations and also for training purposes.

Usually, it is recommended that low altitude flights be performed over smooth terrain at altitudes up to 10 m at speeds not over 10 km/hr, using the air cushion. If flight must be performed between 10 and 50 m altitude, the speed can be increased to 30 km/hr. Flights over broken terrain should be performed at no less than 50 m altitude and at speeds of at least 80 km/hr, in order to avoid the influence of the air cushion. At low flight speeds, the Mi-6 helicopter has increased vibration, so that long, low altitude flights are not recommended.

Low altitude flights and movement should be performed against the wind, when necessary they can be performed with head to side winds or side winds, if the wind speed is not over 10 m/sec, or with tail winds if the wind speed is not over 5 m/sec.

Horizontal flight with externally suspended cargo. In this type of flight, the helicopter has high drag, making it necessary to increase the flight power, increasing fuel consumption per kilometer, decreasing range and load carrying capacity. For example, the maximum weight with externally suspended cargo for the Mi-6 helicopter is 33 T, the maximum cargo weight is 8 T. The flight speed is also limited, and should not exceed 200 km/hr. Furthermore, the speed is set as a function of cargo weight, its size and behavior in flight. The speed is selected so that the cable does not come within 100 mm of the limiter ring and the cargo does not swing.

Flights with externally suspended loads are more difficult for the pilot and have a number of distinguishing features. Swinging of the cargo on the support causes the helicopter to rock, particularly in the longitudinal direction; therefore, it is more difficult to maintain the fixed speed. In order to prevent swinging of the cargo, the proper speed must be selected, the helicopter must be balanced more carefully and accurately, movements of the control levers must be smooth and moderate. This piloting technique is required not only because of the behavior of the cargo, but also because of changes in the effectiveness of control of the helicopter resulting from displacement of the center of gravity of the entire helicopter downward. As we know, the lower the center of gravity of a helicopter in relation to the lifting rotor hub to which the aerodynamic force is applied, the higher the effectiveness of control. Therefore, the required deflections of the automatic swash plate and cyclical pitch lever both in the longitudinal and in the transverse directions will be less. Excessive deflection of the levers may cause pitch and bank angles so extreme that it is difficult or even impossible to pull out of them.

It is also difficult to perform turns with externally supported cargo; therefore, turns must be made quite smoothly, in a coordinated manner and with a bank of not over 10°.

Horizontal flight with one engine in operation. Flight with one engine in operation may be performed for training purposes or in case of failure of one of the engines in flight. Horizontal flight is possible with one engine operating in the takeoff mode with normal flying weight of the helicopter. This type of flight can be continued for training purposes for not over 6 min. The speed should be 130-150 km/hr. The rotating speed of the lifting rotor should be 80-82%. With maximum flying weight, horizontal flight with one engine is impossible, and the helicopter will descend at a vertical speed of 1-2 m/sec. Therefore, horizontal flight of the helicopter with one engine operating is performed for training purposes with the helicopter unloaded at the nominal engine operating mode at 130-150 km/hr at 1,000-1,500 m altitude.

The engine is turned off by the stop valve. It is not recommended that an engine failure be imitated by putting the engine in the idle, due to the high vibrations which arise in the transmission in this case.

These training flights should not exceed 90 min in length.

The engine is turned off at 1,000-1,500 m altitude when operating at no less than 83% speed. The engine is turned off by the flight engineer.

After the engine is turned off, the helicopter will attempt to enter a right turn due to the decreased reactive moment of the lifting rotor, the nose will drop and the rotating speed of the lifting rotor will drop by 5% in 6-7 sec. After the engine is turned off, the pilot should rapidly decrease the general pitch of the rotor by 4-6° and at the same time turn the gas corrector knob to the right, push the left pedal forward, pull the cyclical pitch lever back toward himself, then push both separate control levers into their extreme upward positions, increase the general pitch, establish a speed of 130-150 km/hr, maintain the speed of rotation at 80-83%, then push the separate control lever of the non-operating engine against the catch.

Turns must be performed with one engine operating at not over 15° bank. The stopped engine can be restarted in flight. Usually, stoppage of one engine leads to a landing with one engine operating.

§23. Flying Limitations in Horizontal Flight

1. The maximum and minimum speeds established as a function of type of lifting rotor blades, flying weight of helicopter, flying altitude and placement of cargo must be observed. At less than 50 m altitude, the speed should be not over 30 km/hr.
2. The rotating speed of the lifting rotor is established as a function of blade type of lifting rotor and flying altitude (see Tables 6 and 7).
3. The maximum altitude of horizontal flight for the helicopter at normal flying weight (40.5 T) is 4,500 m, for the helicopter at maximum flying weight (42.5 T) with trapezoidal blades is 1,500 m, with maximum weight and rectangular blades--3,000 m.
4. The minimum permissible altitude for horizontal flight over broken terrain is 50 m, with externally suspended cargo--200 m.
5. Turns in horizontal flight can be performed throughout the entire range of permissible speeds with banks up to 30° for a helicopter at normal flying weight, up to 15° with maximum flying weight and up to 10° when flying with externally suspended cargo. Turns in flight with one engine operating must be made with a bank not over 15°.

6. In helicopters with trapezoidal blades and automatic swash plate control with a limiting forward deflection of $6^{\circ}30'$ with full fuel load, with cargo and with near limiting rear centering should be kept below 200 km/hr until 1,000 kg fuel from tank group IV has been expended in order to retain sufficient longitudinal control reserve.

CHAPTER VII. DESCENT WITH FORWARD MOTION AND LANDING WITH ENGINES OPERATION

§24. Descent with Forward Motion with Engines Operating

General Characteristics of Flying Regime

Descent with forward motion with engines operating is the main form of descent for the Mi-6 helicopter.

When descending with forward speed, the following forces act on the helicopter: the aerodynamic force of the lifting rotor R , the aerodynamic force of the wing R_w , the thrust of the tail rotor T_{tr} , the drag of the helicopter X and weight G (Figure 75). The aerodynamic force of the rotor acts perpendicular to the base of the cone of rotation. The cone of rotation and force R are deflected in the direction of flight using the cyclical pitch lever. Due to flapping motions in forward flight, they are deflected from the plane of rotation to the rear and right. In the coupled coordinate system, force R can be separated into rotor thrust T , longitudinal force H and side force S .

In the flow system of coordinates, rotor thrust T and longitudinal force H are separated into the following components: T_y and T_x and H_y and H_x . In this same system of coordinates, force R_w is separated into Y_w and X_w , the weight--into G_y and G_x .

When descending with forward speed, the following moments act on the helicopter: longitudinal--aerodynamic moment of rotor, wing, stabilizer, fuselage drag, reactive moment of tail rotor and hub moment due to spread of horizontal hinges; track--reactive moment of lifting rotor and tail rotor moment; transverse--tail rotor moment, side force moment and hub moment resulting from spread of horizontal hinges.

In order to observe straight line flight, constant angle of descent and constant vertical descent speed, it is necessary that forces T_y and Y_w balance weight component G_y and longitudinal force component H_y

$$T_y + Y_w = G_y + H_y.$$

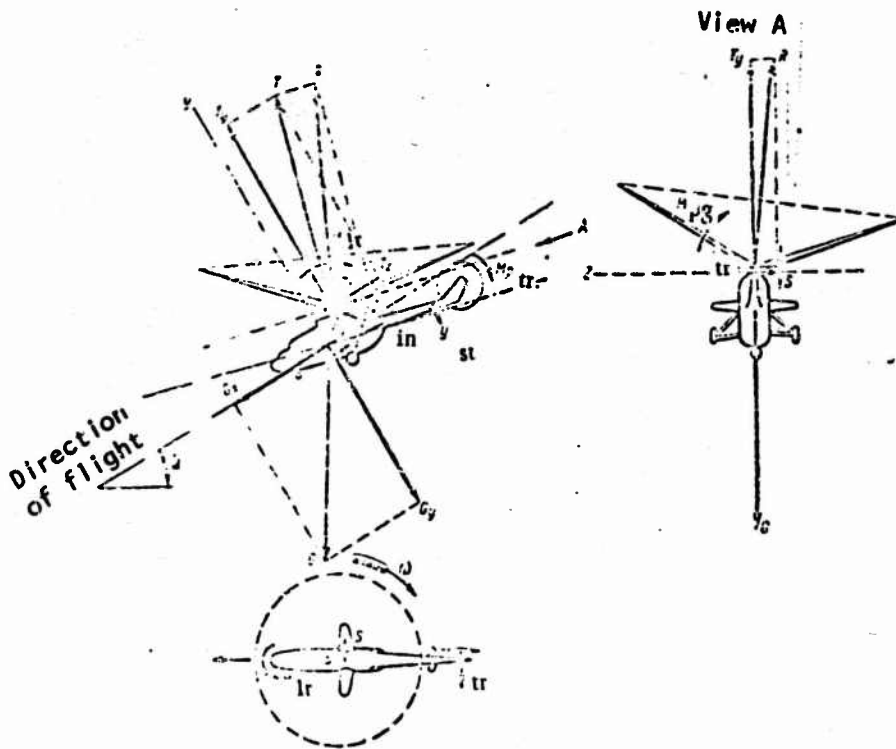

Figure 75. Diagram of Forces and Moments Acting on Mi-6 Helicopter When Descending with Forward Speed (Bank and Slip Not Shown).

It is necessary for even flight that the sum of the thrust component T_x , wing drag X_w , horizontal force component H_x and drag X balance weight component G_x

$$T_x + X_w + H_x + X = G_x.$$

When descending the forward motion, as in other flying regimes, the helicopter is balanced either with a right bank or with left slip. The bank or slip angles will be less than in horizontal flight due to the lower required power. The thrust of the tail rotor is balanced by the same forces as during a climb or horizontal flight.

The diagram of forces and moments shown on Figure 75 will be correct for all cases of descent with operating engines with forward motion, and in other cases only the descent angles will differ.

Descent with forward speed is the flying regime in which the available power at the lifting rotor is less than the required power for horizontal flight of the helicopter, so that descent occurs with the engines operating, at a certain vertical speed. The value of this vertical descent speed depends on the fixed engine power, forward speed, flying weight of the helicopter, atmospheric conditions and altitude.

With any fixed engine power during a descent the minimum vertical speed will occur at the economical forward speed (140 km/hr). At all other flight speeds, the vertical rate of descent will be higher, since the lifting rotor operates under worse conditions at other speeds and develops less thrust, and more vertical speed is required to maintain it. With any forward speed, the vertical speed can be increased or decreased by changing the engine power used.

In a descent with engines operating in the Mi-6 helicopter with forward speed and normal flying weight, the following range of permissible indicated speeds on the descent trajectory has been established as a function of type of blades and flying altitude (Table 9).

TABLE 9. RANGE OF PERMISSIBLE INDICATED SPEEDS WHEN DESCENDING WITH ENGINES OPERATING FOR MI-6 HELICOPTER AT NORMAL FLYING WEIGHT

Altitude, m	Indicated speed, km/hr	
	Trapezoidal Blades	Rectangular Blades
4500—4000	90—110	110—140
4000—3000	90—130	110—160
3000—2000	90—150	110—190
2000—1000	90—200	100—230
1000—0	90—200	100—230

In the Mi-6 helicopter with flying weight above the normal, the following range of speeds is permissible, depending on blade type and flying altitude (Table 10).

TABLE 10. PERMISSIBLE INDICATED SPEEDS ON TRAJECTORY IN DESCENT WITH ENGINES OPERATING FOR MI-6 HELICOPTER AT HIGHER THAN NORMAL WEIGHT

Flying Altitude, m	Trapezoidal Blades	Rectangular Blades
3000—1500	—	110—230
1500—0	120—160	110—230

The recommended speeds in descent depending on blade type and flying altitude are established as follows (Table 11).

TABLE 11. RECOMMENDED DESCENT SPEEDS
FOR MI-6 HELICOPTER AS FUNCTIONS OF
BLADE TYPE AND ALTITUDE

Altitude, m	Trapezoidal Blades	Rectangular Blades
4500-4000	90-110	110-130
4000-3000	100-130	110-140
below 3000	120-140	120-160

If the speed should be less than the minimum permissible, for example when landing at a heliport with high obstacles, when a steeper descent is required, the speed must be maintained at no less than the minimum permissible for horizontal flight.

The vertical descent speed at altitudes from 4,500 to 3,000 m should not be over 4 m/sec, at altitudes below 3,000 m--not over 7 m/sec. The vertical descent rate for the Mi-6 helicopter with over normal flying speed at all permissible altitudes and speeds should be not over 7 m/sec.

At speeds less than the minimum permissible speed in horizontal flight, the vertical descent speed should be not over 3 m/sec, since the helicopter may go into the vortex ring mode.

The rotating speed of the lifting rotor when descending with forward speed and operating engines should be the same as for other flight speeds as a function of altitude and type of blade.

In a stable descent with forward speed and unchanged position of the general pitch and gas corrector levers, the rotating speed of the turbine compressor will decrease, but the engine power will remain unchanged. The rotating speed of the lifting rotor will decrease as a result of the increased air density. As the helicopter approaches the earth, the pilot should decrease the general pitch of the lifting rotor, maintaining the required vertical descent rate, maintaining the recommended or permissible rotating speed using the gas corrector as a function of altitude and type of blade (see Tables 6 and 7).

Descent with forward speed with the engines operating can be performed along a descending spiral, in which case the speed should be retained within the limits shown in Table 9, the vertical speed should be not over 3 m/sec and the bank should be not over 15°. Descent with forward movement with cargoes on the external hook requires particular attention on the part of the pilot. The transition from horizontal flight to descent causes unbalancing and swinging of the cargo. When the cargo lags behind,

a diving moment acts on the helicopter, which must be decreased by deflecting the cyclical pitch lever back. Descent should be performed at 110-120 km/hr (depending on the behavior of the cargo) with a vertical speed of not over 2-3 m/sec.

Descent can also be performed with one engine turned off for training purposes or in case of failure of one engine, the speed recommended being 130-140 km/hr, with a vertical descent rate of not over 4 m/sec.

Specifics of Performing Descent with Forward Motion with Engines Operating

In order to make the transition from the horizontal flight mode to the mode of descent with forward motion, the required speed must be maintained, maintaining the required vertical speed with the general pitch lever and seeing to it that the rotating speed of the lifting rotor remains within the recommended limits. The pitch-gas system of the Mi-6 helicopter is such that when the general pitch lever is moved downward, the rotating speed of the lifting rotor increases as it is lightened, so that the gas corrector must be backed off in order to retain the predetermined rotating speed.

As the general pitch is decreased, the helicopter tends to pitch, since the stabilizer is set at a negative setting angle; consequently, in order to prevent pitching the cyclical pitch lever must be moved forward to retain the helicopter in the proper flying regime. At the same time as the general pitch is decreased, the reactive moment of the lifting rotor is decreased, so that the thrust of the tail rotor must be decreased by moving the left pedal forward. However, in order to avoid slipping, since the side force remains at before, the cyclical pitch lever should be moved to the left in order to decrease the side force.

If the descent is made in order to perform a landing, the speed should be 150 km/hr, the vertical descent rate 2-3 m/sec. The general pitch in this case will depend on the weight of the helicopter: the heavier the helicopter, the higher the general pitch required to maintain the same vertical descent rate. For normal flying weight, when descending from less than 500 m, the general pitch will be approximately 3° , the indication of the UPRT--35-40°.

If it is necessary to shift the helicopter from the regime of descent with forward motion to the regime of horizontal flight, first of all the general pitch of the lifting rotor must be brought up to the required level, while preventing left turn due to the increased reactive moment by moving the right pedal simultaneously; the control lever is moved to the right to prevent left slip. When the general pitch lever is moved upward, the rotating speed of the lifting rotor will decrease as its weight increases, so that the gas corrector must be rotated to the right in order to maintain the required rotating speed.

Flying Limitations in Regime of Descent with Forward Motion

1. The forward speed should be retained as required by the type of blades, flying weight and flying altitude, in the limits indicated in Tables 9 and 10. When necessary, minimum speeds below those indicated in the tables are permitted, but they should never be below the minimum permissible speed for horizontal flight at the altitude in question.

2. The recommended descent speeds, depending on type of blades and altitude, are outlined in Table 11. When descending with one engine operating, the recommended speed is 130-140 km/hr.

3. The vertical rate of descent for a helicopter with normal flying weight at altitudes from 4,500 to 3,000 m should be not over 4 m/sec, at altitudes below 3,000 m--not over 7 m/sec. With a speed less than the minimum permissible speed (when landing) the vertical speed should be not over 2-3 m/sec. For a helicopter with flying weight over the normal, the vertical speed at all altitudes should not be over 7 m/sec. When descending with one engine operating, the vertical descent speed should be not over 4 m/sec.

4. The rotating speed of the lifting rotor should be kept within the permissible limits, depending on type of blade and flying altitude, shown in Table 7.

§25. The Landing

General Information

For the helicopter, the landing is the final stage of flight and is its most difficult element. The following types of landings are used by the Mi-6 helicopter: with engines operating with forward speed (aircraft type), vertical with engines operating (helicopter type), with one engine operating with forward speed (aircraft type) and in autorotation mode of lifting rotor with engines not operating. In this chapter, we will analyze aircraft type and vertical landings with engines operating. Landing with one engine operating will be analyzed in Chapter X, landing in the autorotation mode of the lifting rotor for training purposes--in Chapter VIII.

For the Mi-6 helicopter, the aircraft type landing is the principle type of landing, since it requires the least power and can be used by the helicopter both with normal and with maximum flying weight. In addition to these advantages, the helicopter will not undergo increased vibrations ("shaking regime"), which is observed at flying speeds of less than 60 km/hr. With the aircraft type landing, the helicopter requires a considerable run length and landing distance, so that this type of landing is possible only at permanent or temporary type 1 heliports for heavy helicopters.

The vertical (helicopter type) landing is used if an airplane type landing cannot be used (when landing at type 2 heliports, where the size and approach do not permit airplane type landings or if the surface of the heliport does not allow a long landing run). The limiting landing weight for vertical landings is determined using the same nomograms used to determine the takeoff weight, since the power conditions of landing are the same as for takeoff, and the necessity of possible repetition of the landing approach must be considered. If the altitude of the heliport is over 500 m above sea level, a correction to the weight for a landing using the air cushion effect must be calculated using the same nomogram as for a takeoff, although the test hover height is not determined, since it is not required in a landing.

The run length and landing distance for an airplane type landing, as well as the landing distance for a vertical landing, flying tests have established, are less than the run length and takeoff distance for an airplane type takeoff or the takeoff distance with a vertical takeoff. As has been stated above, there are no nomograms for determination of takeoff-landing characteristics of the Mi-6 helicopter. All heliports for heavy helicopters are constructed by calculating not the landing, but the takeoff characteristics of the Mi-6 helicopter, so that the dimensions and approaches to heliports for heavy helicopters, if they correspond to the technical requirements, allow landings to be performed at any time of year and under any weather conditions. Landing the Mi-6 helicopter by selecting the landing area from the air for dusty, sandy or snow covered heliports is not permitted.

Airplane Type Landing

Airplane type landings with the Mi-6 helicopter are performed only at type 1 heliports with artificial or natural runway surfacing. The landing is preceded by a gradual descent.

The airplane type landing consists of the following stages: decrease in speed from 100-80 m altitude with subsequent increase in power to maintain and decrease vertical descent speed, touchdown and landing run (Figure 76).

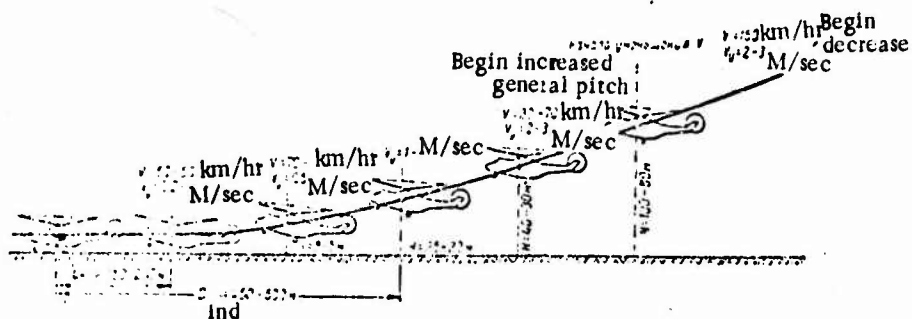

Figure 76. Profile and Elements of Airplane Type Landing for Mi-6 Helicopter.

After turning onto the landing line, a descent angle must be taken so that the intended landing point is projected on the central portion of the side glass (with electric heater). The value of general pitch and UPRT indication should be selected to provide a speed of 150 km/hr and a vertical descent rate of 2-3 m/sec. The general pitch and rotating speed of the lifting rotor must be set so that during further descent and touchdown, movement of the general pitch lever upward or downward does not lead to a great change in the rotating speed, carrying it beyond the permissible limits (i.e., the attention of the pilot should not be distracted to observe the rotating speed of the lifting rotor during the landing process).

The landing is begun from an altitude of 100-80 m, at which point the speed must be decreased by deflecting the cyclical pitch lever backward. The rate of movement of the lever should be such that at 40-30 m altitude the speed has been reduced to 70-80 km/hr. As the speed is decreased, the vertical speed remains unchanged, 2-3 m/sec, although the required power at the lower speed increases, but due to the lower angle of attack of the lifting rotor the rotor thrust decreases. When 70-80 km/hr is reached, the vertical rate of descent begins to increase. The general pitch lever must be moved upward smoothly to increase power in order to prevent increased rate of descent. The rate and degree of movement of the "pitch-gas" lever should be such that the descent to the landing is adjusted by changing the vertical rate of descent. At 25-20 m altitude, the general pitch should be increased in order to decrease the vertical descent rate to 1-2 m/sec. With this descent rate, the helicopter should descend to the intended point, approaching it at an altitude of 5-6 m and a speed of 60-70 km/hr, with a vertical speed of 0.5 m/sec. At this point, the cyclical pitch lever is moved forward in order to decrease the pitch angle and put the helicopter in the landing position (on the main wheels), and at the same time the general pitch lever is raised slightly in order to further decrease the vertical rate of descent. If the cyclical pitch lever is not moved forward or is moved forward insufficiently, the tail support of the helicopter may strike the ground. If the cyclical pitch lever is moved forward too far at 5-6 m altitude, the helicopter may make a three point landing, which is incorrect.

If the pilot performs properly, the helicopter should land on the main wheels at 50-60 km/hr with a vertical speed of 0.1-0.2 m/sec.

The landing speed may be higher as a result of beginning the decrease in speed later (below 100-80 m) or as a result of coasting at low altitude in order to correct the landing point. In this case, the landing run will be longer. If there is not sufficient room for the landing run, and if the error is noticed, the pilot should begin ascending again from an altitude of 5-6 m, to go around and try again.

After touchdown on the main wheels, the cyclical pitch lever must be held in the same position; the helicopter will let its front wheel down by itself. Then the general pitch is decreased to the minimum, and the gas corrector is turned fully to the left. Dropping the general pitch lever to the stop and rotating the corrector to the left all the way must be done, since otherwise ground resonance may occur.

During the first half of the run, braking is performed by moving the cyclical pitch lever, during the second half of the run--by the wheel brakes. The direction of the run is maintained by smooth movements of the pedals.

The length of the landing run depends on the landing weight of the helicopter, landing speed and atmospheric conditions, as well as the quality of the runway surface. Flying tests have established that, depending on these conditions, the landing run length of the Mi-6 helicopter should be 150-250 m, the landing distance--450-600 m. Airplane type landings with the Mi-6 helicopter are possible with side winds up to 10 m/sec and with tail winds up to 5 m/sec.

On sandy or dusty heliports or similar areas, airplane type landings can be performed when necessary. However, this type of landing has certain peculiarities, depending on the direction and strength of the wind as well as the size of the heliport. In this case, the landing must be performed against the wind in order to assure good visibility. If the head wind is over 5 m/sec, the landing is performed as usual. Visibility will be good throughout the entire landing run. With a head wind of less than 5 m/sec, depending on the size of the landing area, various landing speeds should be used. If the area available for the landing run is over 300 m long, the ordinary landing speed is used (50-60 km/hr, no less). If the length of the landing strip is 300 to 100 m, the landing speed should be decreased, but no less than 30-35 km/hr. If horizontal visibility is decreased at this reduced speed due to dust thrown up by the air blast, the pilot should go around again and touchdown the second time at higher speed.

Airplane type landings on snow covered heliports or areas should be performed only with the snow rolled down firmly. With freshly fallen snow, the same recommendations should be observed as when landing on sandy or dusty heliports.

Brief description of method of performing airplane type landing. After the fourth turn, a speed of 150 km/hr is taken up, vertical descent rate 2-3 m/sec. At 100-80 m altitude, the speed is decreased by pulling the cyclical pitch lever back, so that by 40-30 m the speed is 70-80 km/hr. As speed continues to drop, the power must be simultaneously increased by moving the general pitch lever upward so that at 25-20 m altitude the vertical rate of descent is 1-2 m/sec, at 5-6 m it is 0.5 m/sec and

at the moment of touchdown the landing speed is 50-60 km/hr, the vertical speed 0.1-0.2 m/sec. In order to be sure the helicopter touches down on the main wheels, from 5-6 m down the cyclical pitch lever must be carefully moved so as to take up a landing position. After touchdown, the general pitch lever is dropped to the stop, the gas corrector is rotated fully left, the helicopter drops down until the front wheel touches. The brakes are used to decrease the length of the landing run.

When coming into a landing with a side wind, the tendency to drift is eliminated by adjusting the course, then beginning at an altitude of 50-60 m--by banking against the wind, countering the attempt to turn by deflecting the pedals in the direction opposite to the bank. Before touchdown, the bank must be eliminated and the pedals deflected in the direction of the drift to allow the wheels to strike the ground straight. During the run, the direction is maintained by moving the pedals in the direction opposite to the turn.

Vertical Landing

A vertical landing is used if it impossible to perform an airplane type landing, and also when landing with cargo supported externally. Like a vertical takeoff, a vertical landing is performed using the air cushion or outside the zone of influence of the air cushion.

Vertical landing with hovering in the zone of influence of the air cushion is performed at permanent or temporary type 1 heliports (like the airplane type landing), the dimensions and approaches of which allow this type of landing to be performed, but when the condition of the surface or small obstacles do not allow the run to be performed on the surface.

The limiting landing weight of the helicopter for this type of landing is determined using the same nomograms as are used to determine the limiting takeoff weight (see Figure 55). If the barometric altitude of the heliport is over 500 m; a correction to the flying weight is determined using the nomogram of Figure 56.

The landing is preceded by a planned descent. The height of exit from the fourth turn should be at least 150 m. The principle of the descent to the landing after entering the landing course remains the same as for the airplane type landing. The speed of descent before the landing should be 120-140 km/hr, with a vertical component of 2-3 m/sec.

A vertical landing consists of the following stages: decrease in speed from 100-80 m altitude to hovering with simultaneous increase in power, beginning at a speed of 80-70 km/hr, brief hovering at 2-3 m altitude and vertical touchdown at 0.1-0.2 m/sec (Figure 77).

The landing is begun on the last leg at 100-80 m altitude; the decrease in speed is begun at this altitude by pulling the cyclical pitch lever back, as in the airplane type landing. The deflection of the

cyclical pitch lever should be such that at 40-50 m the speed is 80-70 km/hr. From this moment, the general pitch must be increased, since otherwise the vertical speed will increase in spite of the increased angle of attack of the lifting rotor resulting from deflection of the cyclical pitch lever. Therefore, when a speed of 80-70 km/hr is reached, the general pitch lever must be moved upward to decrease the vertical descent speed, while continuing to decrease the forward speed. The pilot must be sure that the rotating speed of the lifting rotor stays within the permissible limits: it should be the same as in horizontal flight, depending on the type of blades and flying altitude. If the rotating speed decreases as the general pitch lever is moved upward, it must be maintained by rotating the gas corrector knob to the right.

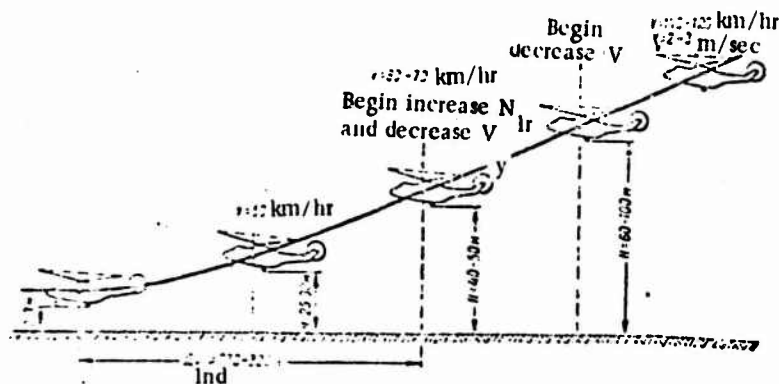

Figure 77. Profile and Elements of Vertical Landing with Hovering in the Zone of Influence of the Air Cushion in Mi-6 Helicopter.

When a speed of 60 km/hr is reached, which should be at a height of 25-30 m, increased vibration of the Mi-6 helicopter will occur ("shaking regime"), more sharply expressed than that of the Mi-4 helicopter and stronger than when the Mi-6 helicopter is accelerated after hovering. This is explained by the fact that the Mi-6 helicopter has high flying weight and consequently high inductive speed, so that the vortex system in forward flight is more difficult to restructure into the vortex system of hovering flight. As the speed is decreased, the vibration will be stronger than in acceleration, since acceleration can be performed rapidly, while deceleration must be performed slowly, since due to the high mass of the helicopter the pitch angle might otherwise exceed the permissible limits, making the landing impossible. In order to decrease vibrations as rapidly as possible, beginning at 60 km/hr the speed should be decreased not only using the cyclical pitch lever, but also using the general pitch lever, since the thrust of the rotor is deflected to the rear and when the general pitch is increased the speed drops quite rapidly. Also, if there is a power reserve, the setting of the general pitch lever, beginning at 30-20 km/hr, should be such that the deceleration

continues with a slight increase in altitude. By using the general pitch lever in this manner, the pilot creates a higher inductive velocity, and the vortex system of forward flight is more rapidly restructured into the vortex system of hovering flight. The rate of movement of the general pitch lever should be such that hovering occurs at 2-3 m altitude. With this method of landing, the time required for the helicopter to pass through the "shaking regime" will be minimal, 10-15 sec.

During the process of deceleration, as during acceleration in take-off, the helicopter will be unbalanced as a result of the decrease in speed, increase in engine power and reactive moment of the lifting rotor. The helicopter must be balanced by moving the right pedal forward and simultaneously moving the cyclical pitch lever to the right and rear. Furthermore, the following fact must be kept in mind: if the decrease in speed occurs smoothly, beginning at 100-80 m altitude, and the vertical speed drops off gradually from 70-80 km/hr, by the moment the hovering regime is reached the pitch angle will be normal; if the acceleration is energetic, hovering will begin with a high pitch angle, requiring that the cyclical pitch lever be moved forward in order to move the helicopter to the normal pitch angle, while preventing descent due to the deflection of the thrust to the rear and resulting decrease in its vertical component by moving the general pitch lever upward.

Before hovering and at the moment of hovering, the pilot must be careful not to overweight the lifting rotor and decrease the rotating speed below the permissible level.

A stable hover should be achieved, after which the descent should be resumed, without allowing the helicopter to shift its horizontal position. The vertical speed at the moment of contact with the earth should be 0.1-0.2 m/sec. The Mi-6 helicopter, like the Mi-4, settles first on the right wheel, since it hovers with a right bank, then on the left wheel and finally on the nose wheel. The general pitch can be decreased only after the pilot is certain that the helicopter is resting firmly on all three wheels.

A vertical landing in the zone of influence of the air cushion, like the airplane type landing, should be performed against the wind. When necessary, this landing can be performed with a side wind of up to 10 m/sec or tail wind of up to 5 m/sec. Landing with the side wind from the left is more favorable than with the side wind from the right, since when the wind is from the left the control reserve is greater in the cyclical pitch lever in the lateral direction. After hovering, the helicopter should be rotated against the wind before touchdown. The landing distance for a vertical landing is 230-300 m.

During the vertical landing, the pilot can move away for a second try from any altitude, even after hovering. In order to move away for a second try, the power should be increased using the general pitch lever, and

the rotating speed maintained within the permissible limits (78-83%), the helicopter should be moved forward using the cyclical pitch lever and put into a climb. The distance required to climb to 25 m when moving away for a second try depends on the flying weight of the helicopter, power applied and speed of climb. The higher the weight and higher the forward speed of climb, the greater the climbing distance. For example, the following data were produced in one test flight: with a helicopter weight of 38 T, using takeoff power with a forward speed of 60 km/hr, the distance was 270 m, with a forward speed of 80 km/hr-- 370 m.

Vertical landings on sandy or dusty heliports should be performed against the wind, and if the head wind is over 5 m/sec the landing will be normal, since the visibility will be normal. If the landing is less than 5 m/sec, vertical landings are permitted only if the area has been thoroughly wet with water.

A vertical landing on a snow covered heliport is possible, but in this case the decrease in forward speed is performed at a rate (decreased) such that the snow blown up lags behind the helicopter and "covers" it only as it hovers over the point of touchdown. During this time, visibility may be decreased for 1-2 sec, so that the altitude of the helicopter must be maintained using the instruments in the normal position, and vertical descent and touchdown performed only after visibility clears and the touchdown mark can be seen.

Vertical landings on areas with freshly fallen or loose snow are forbidden, since visibility will be very poor and piloting quite difficult.

Brief description of method of performing vertical landing in zone of influence of air cushion. The descent before landing is performed at 120-140 km/hr with a vertical descent speed of 2-3 m/sec. At an altitude of 100-80 m, the speed is decreased using the cyclical pitch lever so that at 40-50 m the speed is 70-80 km/hr. Starting at this moment, the general pitch of the lifting rotor should be increased by moving the general pitch lever upward, using the gas corrector to retain the rotating speed of the lifting rotor within the permissible limits, depending on the type of blades. When a speed of 60 km/hr is reached at an altitude of 25-30 m, the rate of movement of the general pitch lever must be increased, so that the helicopter hovers at an altitude of 2-3 m. During the process of decreasing speed and increasing power, the helicopter must be balanced in direction, bank and altitude using all control levers, relieving pressure on the levers by using the trimmers. After hovering, a vertical touchdown is made at a vertical speed of 0.1-0.2 m/sec. Before touchdown, no lateral movements are permitted. When the pilot is quite certain that the helicopter is resting firmly on the ground, the general pitch of the lifting rotor is decreased to the minimum.

Vertical landing with hovering outside zone of influence of air cushion is used at type 2 heliports, which do not allow the air cushion

effect to be used, and also when transporting cargoes suspended externally.

This type of landing consists of the same stages as the landing performed in the zone of influence of the air cushion, except that hovering is performed at a height of 10-15 m above all obstacles, i.e., outside the zone of influence of the air cushion. This type of landing is possible if there is sufficient power reserve to allow hovering at the proper altitude outside the zone of influence of the air cushion. The limiting flying weight for this type of landing is determined using the nomograms (Figure 59).

The profile and elements of a vertical landing with hovering outside the zone of influence of the air cushion are shown on Figure 78. With this type of landing, the decrease in speed, hover and vertical descent are performed in the danger zone in the case of engine failure, so that this type of landing should be used only in exceptional cases (with externally suspended cargo, at a type 2 heliport, during emergency rescue operations and first aid operations). Wind limitations for this type of landing are the same as for a landing in the zone of influence of the air cushion.

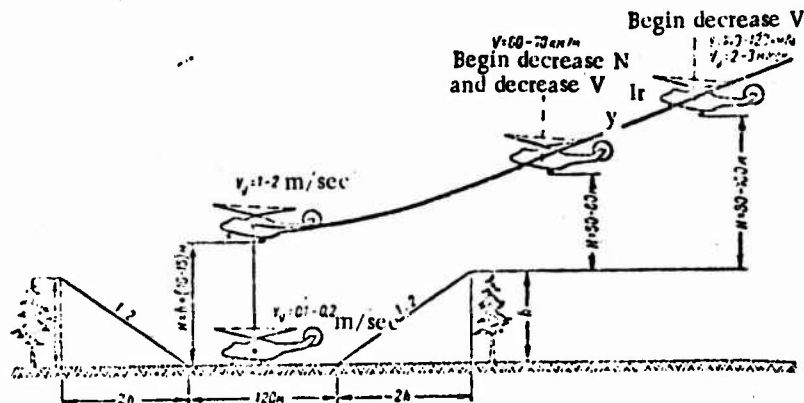

Figure 78. Profile and Elements of Vertical Landing with Hovering Outside Zone of Influence of Air Cushion.

The method of performing this type of landing, right up to the moment of hovering, is the same as the method of vertical landing with hovering in the zone of influence of the air cushion. Vertical descent after hovering must be performed at a vertical speed of not over 1-2 m/sec, since any increase in this speed (particularly over 2-3 m/sec) may result in the vortex ring mode. By the moment of touchdown, the vertical speed should be 0.1-0.2 m/sec. At dusty, sandy or snow covered heliports, this type of landing is performed with the same limitations as the landing with hovering in the zone of influence of the air cushion.

The vertical landing with externally suspended cargo has a number of peculiarities. Due to the lag of the cargo behind the helicopter, a diving moment acts on the helicopter, so that in order to maintain a fixed forward speed, the cyclical pitch lever should be deflected backward to a greater extent than when the cargo is located inside the cabin. The descent before the beginning of deceleration must be performed with a forward speed which is dependent on the behavior of the cargo and with a vertical speed of 2-3 m/sec. The last turn onto the landing course must be made somewhat earlier than in ordinary flight in order to allow speed to be decreased smoothly, preventing rocking of the cargo and making piloting easier. A sharp decrease in speed will cause the cargo to swing forward, as a result of which a great upward pitching moment will arise, causing an unexceptable angle of pitch. Speed must be decreased gradually, smoothly increasing the power. The usual rate of deceleration will lead to swinging of the cargo in the longitudinal direction. Even a normal rate of deceleration will cause the cargo to swing somewhat forward, so that the horizontal thrust component of the lifting rotor is deflected backward, causing a considerable upward pitching moment, forcing the pilot to hold the cyclical pitch lever in the forward position.

As the helicopter is decelerated for the descent, the rotating speed of the lifting rotor may increase; therefore, in order to retain it the general pitch must be increased, while holding the gas corrector knob in the central position. Increasing the general pitch at the end of deceleration may cause the rotating speed of the lifting rotor to drop below the permissible level, increasing the vertical descent rate. In order to avoid this, the gas corrector must be smoothly rotated so that by the moment of hovering it is fully rotated to the right. The descent and deceleration must be performed so that the helicopter hovers above the point where the cargo is to be lowered, with the cargo at 3-5 m above the ground. If the deceleration has been performed too early, the helicopter should be allowed to hover short of the point of placement of the cargo, with the cargo at least 3 m above the surface of the ground, then the helicopter should approach the desired point of placement of the cargo at 5-10 km/hr. If the decrease in speed was begun late and the speed has not reached zero by the time the helicopter passes the desired point of placement of the cargo, the pilot should increase his speed without decreasing power, climb and repeat his approach to the landing area.

At a speed of less than 60 km/hr, as in an ordinary vertical landing, increased vibration will arise ("shaking regime"), which should be reduced using the same method as is used in a vertical landing with cargo inside the cabin.

After the stable hover is achieved, the "pitch-gas" lever should be used to lower the cargo smoothly at a rate of not over 0.2-0.3 m/sec.

After the cargo touches ground, the helicopter should be allowed to descend further in order to release the cargo.

Hovering of the helicopter with the cargo on the external hook and vertical descent must be performed strictly against the wind in order to assure safety and make piloting easier.

Flying Limitations During Landing

1. Landing can be performed with a head wind of up to 25 m/sec, a side wind up to 10 m/sec and a tail wind up to 5 m/sec.
2. Vertical landings are forbidden on dusty or sandy heliports with a head wind of less than 5 m/sec, or with a side or tail wind.
3. Vertical landings are forbidden at heliports with freshly fallen, loose snow.
4. Landings can be performed only at airfields and heliports, both temporary and permanent, or areas selected in advance and corresponding to the technical requirements for civil aviation heliports.

Specifics of Vertical Takeoffs and Landings at Mountain Heliports

One specific feature of the pitch-gas system of the Mi-6 helicopter is that with increasing altitude of the heliport above sea level or increasing air temperature, or with decreasing atmospheric pressure, the lifting rotor is lightened with any pitch and with the gas corrector fully to the right, i.e., its rotating speed increases and may go beyond the maximum permissible speed. Therefore, at heliports located at high altitudes, vertical takeoff, hovering, vertical flying regimes and vertical landings should be performed using the gas corrector, i.e., it should be held in some intermediate position rather than the far right position. At heliports located at altitudes near sea level, the gas corrector is generally used with the general pitch in a low position (2-5°), while with increasing altitude of the heliport, the gas corrector must be used even with higher pitch, over a broader range of pitch, the higher the altitude of the heliport (Figure 79a).

As is known from piloting practice during the deceleration before the landing, leading up to hovering at medium altitude heliports, the gas corrector must be used to retain the permissible rotating range. The corrector must be used even more frequently in decelerating before a landing in high mountain areas (Figure 79b).

It is also known that when the gas corrector knob is rotated, the rotating speed changes slowly at first, then more rapidly. This is particularly noticeable as the altitude of the heliport above sea level increases. In order to retain the rotating speed within the permissible limits, the engine must be controlled with smooth, slight, repeated movements, moving the gas corrector before the rotating speed reaches the limit.

NOT REPRODUCIBLE

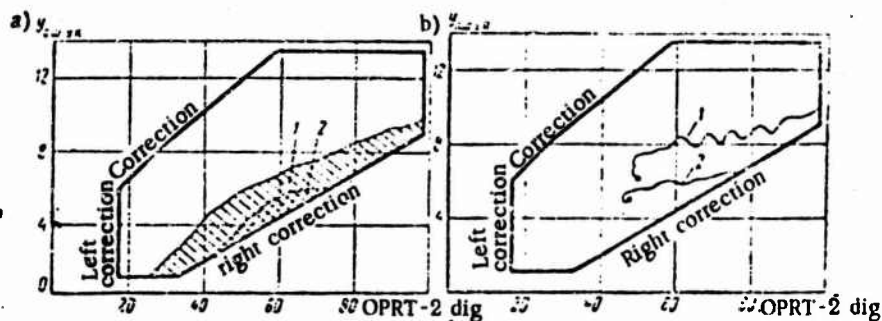

Figure 79. Use of Gas Corrector at Heliports at Various Altitudes Above Sea Level: a, Vertical flying regimes; b, Regime of deceleration before landing: 1, High mountain heliport; 2, Heliport at altitude near sea level.

In order to produce the maximum hover altitude or allow a takeoff with high flying weight, the engines should be put in the takeoff regime, and the rotating speed of the lifting rotor should be at the optimal level (78-80%). If the rotating speed of the lifting rotor is higher or lower than this level with the same engine power, the thrust of the lifting rotor will be decreased. As the altitude of the heliport increases, the optimal rotating speed increases, approaching its upper limit of 86%. Therefore, a pilot flying at high altitude heliports should use his gas corrector quite precisely, since the range of rotating speeds between the maximum permissible and the optimal speeds decreases.

In order to improve the thrust characteristics of the lifting rotor, the pilot must also adjust the general pitch. Adjustment of the general pitch can be performed to produce various rotating speeds of the lifting rotor with the same power level, for example when hovering: high rotating speed of a "light" rotor or low rotating speed of a "heavy" rotor. If the rotor is "heavy," it will not develop the optimal rotating speed at which the thrust is maximum, and the highest hovering height or maximum takeoff weight cannot be achieved. Even if there is a considerable reserve of engine power, when the pilot attempts to increase the thrust by moving the "pitch-gas" lever upward, the rotating speed will simply decrease, until it reaches its minimum permissible level. If the rotor is "light," the optimal rotating speed can be achieved by making the rotor heavier by moving the general pitch lever higher.

A heavy rotor not only worsens the thrust characteristics, but also decreases the reserve of travel of the right pedal during a vertical takeoff, landing or hovering. As we know, the lower the rotating speed of the lifting rotor for the same power level, the greater the reactive moment of the lifting rotor.

Consequently, in order to balance the increasing reactive moment, greater forward travel of the right pedal is required. At the same time, as the altitude increases with the same rotating speed and power, the

required right pedal travel increases, the control reserve decreases due to the decreased thrust of the tail rotor resulting from decreasing air density.

At high mountain heliports, during hovering in the takeoff engine regime with the lifting rotor turning at 79-80%, there is practically no more right pedal travel reserve. Consequently, it is dangerous to hover, takeoff, land or maneuver, particularly near obstacles or in windy weather. In order to assure the required right pedal travel reserve, the rotating speed of the lifting rotor should be increased; if it has reached the upper limit, the power must be decreased, i.e., the flying weight of the helicopter must be decreased, as required by the nomograms for calculation of the limiting flying weight of the helicopter for takeoff and landing. If the pilot is not sure he has a sufficient reserve of right pedal travel, in order to assure safe landing he should hover in a location where it will be possible to move away for a second try, expend a portion of its fuel and then repeat the landing. If the fuel reserve is slight, the landing should be performed at a heliport at lower altitude.

When taking off from a high mountain heliport, the reserve of right pedal travel can be easily determined by rising to the test hover altitude (the reserve should be at least 10 mm).

A side wind decreases the reserve of right pedal travel during vertical takeoffs, landings and vertical flying regimes, since the tail rotor rotating against the wind receives a direct rather than a slanted airflow, thus reducing the thrust of the tail rotor; consequently, in order to retain it within the required limits, high tail rotor pitch is required, produced by large right pedal movement. The control reserve is decreased particularly sharply during a right turn, and the higher the speed of the side wind (from the left) the lower the reserve of right pedal travel. It is also difficult to stop a left turn, since during a turn to over 60-70° the helicopter tends to increase its speed of rotation as a result of the decreased efficiency of the tail rotor with a wind from the right.

CHAPTER VIII. GLIDING AND LANDING IN AUTOROTATION MODE

526. Gliding

General Characteristics of Gliding Mode and Diagram of Forces Acting on Helicopter

The Mi-6 helicopter can glide in the autorotation mode with the engines operating at the idle (for training purposes) or with the engines inoperative (in case of failure) or with engines stopped in case of a landing in the autorotation mode.

Early versions of the Mi-6 helicopter had a controllable wing, i.e., its setting angle could be changed as desired by the pilot: for flights with engines operating, the wing was set at high setting angles-- 15° , while in the autorotation mode of the lifting rotor it was set at low angles-- 5° in order to prevent flow separation and improve the gliding regime characteristics. However, flying practice and flight tests have shown that the behavior of the helicopter in the autorotation mode with a wing setting angle of 15° differs very little from its behavior when gliding at a setting angle of 5° (the gliding characteristics are slightly worse). Therefore, later models of the helicopter have included a fixed wing, and helicopters with the controllable wing have been modified to fix the wing. This also simplifies the design and decrease the number of failures of the system.

When gliding in the autorotation mode, the following forces and moments act on the Mi-6 helicopter (Figure 80). The lifting rotor creates total aerodynamic force R , which is deflected by the cyclical pitch lever forward from the vertical by some angle. Due to the flapping movements, this force and the cone of rotation are moved to the rear and right. However, the pilot balances the helicopter during gliding by deflecting its cyclical pitch lever to the left as required. Force R in the helicopters system of coordinates is separated into thrust T , longitudinal force H and side force S , directed to the left along the plane of rotation of the lifting rotor. In the flow system of coordinates, the thrust and longitudinal force are each separated into two components: T_x and T_y , H_x and H_y . The thrust of the tail rotor is directed to the right by deflecting the pitch of the tail rotor to negative angles by moving the left pedal forward.

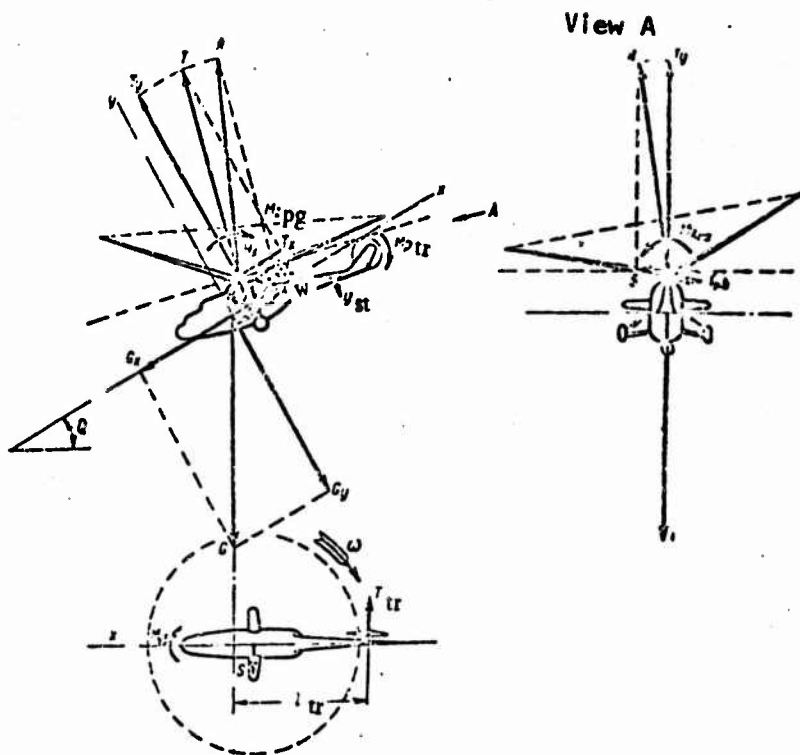

Figure 80. Diagram of Forces in Moments Acting on Mi-6 Helicopter During Gliding in Autorotation Mode.

Total aerodynamic force R_w acts on the wing, and can be separated in the flow system of coordinates into lift Y_w and drag X_y . The drag of the helicopter X and weight of the helicopter G also act on the helicopter. The weight in turn is divided into two components: G_y and G_x . Bank and slip are not shown on Figure 80.

The following moments act on the helicopter during gliding: the longitudinal moment of aerodynamic force R of the rotor, the longitudinal moment of the wing, the rotating moment of the lifting rotor, directed to the right, the track moment of the tail rotor, the longitudinal and transverse moments of the hub resulting from the spread of the horizontal hinges, the transverse and longitudinal moments of the tail rotor, the transverse moment of the side force and the longitudinal moment of the stabilizer.

In order to retain straight flight and constant glide angle, it is necessary that the sum of forces T_y and Y_w be balanced by the weight component G_y and the longitudinal force component H_y

$$T_y + Y_w = G_y + H_y$$

It is necessary for even flight that the sum of forces making up thrust T_x , longitudinal force H_x , helicopter drag X and wing drag X_w be balanced by the weight component G_x

$$T_x + H_x + X + X_w = G_x.$$

In contrast to descent with operating engines, in the gliding mode the sum of all aerodynamic forces acting on the lifting rotor and the helicopter is directed vertically upward and equal to the weight of the helicopter.

In order to observe longitudinal equilibrium, it is necessary that the sum of all longitudinal moments be equal to zero: $\Sigma M_{\text{long}} = 0$.

In the lateral direction, in contrast to flying regimes with the engines operating, the helicopter is balanced either with a left bank or with right slip. The angles of bank or slip are quite small. When flying with the left bank, the thrust of the lifting rotor is balanced by side force S of the lifting rotor and weight component G_z , while when flying with a right slip, it is balanced by side force S of the lifting rotor and side fuselage force Q_z .

Rotating Speed of Lifting Rotor and Speed of Descent

Rotating speed of lifting rotor. In the Mi-6 helicopter in the autorotation mode, the rotating speed of the lifting rotor is maintained using the general pitch lever: in order to increase the rotating speed, the general pitch is decreased, while it is decreased by increasing the general pitch. The rotating speed of the lifting rotor in the autorotation mode should be maintained within the range of permissible and recommended speeds for horizontal flight, depending on altitude and type of blades (see Table 6 and 7). In order to maintain the rotating speed within this range, the general pitch should be 5° at 3,000 m altitude, 4° at 2,000 m, 1° at 1,000 m and less. Furthermore, the rotating speed of the lifting rotor will also depend on the flying weight of the helicopter: the less the weight, the lower the rotating speed of the lifting rotor. When gliding with the helicopter unloaded, even at the minimum general pitch (1°), the rotating speed of the lifting rotor may fall below the minimum permissible level (see Table 6). In this case, minimal rotation speeds of 76-78% are permitted. Consequently, adjustment of the general pitch lever of the lifting rotor should be performed so that the rotating speed does not fall below 76-78%.

The rotating speed of the lifting rotor also changes significantly with the gliding speed along the trajectory: the higher the gliding speed, the lower the rotating speed, since the conditions for autorotation of the rotor are worsened at high flying speeds. A change of speed of

100 km/hr causes a change in rotating speed by approximately 5%. However, since the range of recommended speeds in the autorotation mode is small, the change in rotating speed resulting from a change in flight speed is hardly noticed, and has no practical significance.

Forward speed. For the Mi-6 helicopter, the forward speed in the autorotation mode can in principle be anywhere within the range of permissible speeds of horizontal flight. However, in order to simplify piloting and provide safety, the following permissible range of indicated speeds has been set for the rotor with trapezoidal blades:

Height, m	Speed, km/hr
3,000.....	130-160
2,000.....	120-180
1,000 or less.....	120-200

For the helicopter with rectangular blades, the range of permissible speeds is 120-250 km/hr. At speeds lower than or higher than the recommended speeds, increased vibration of the helicopter will be observed.

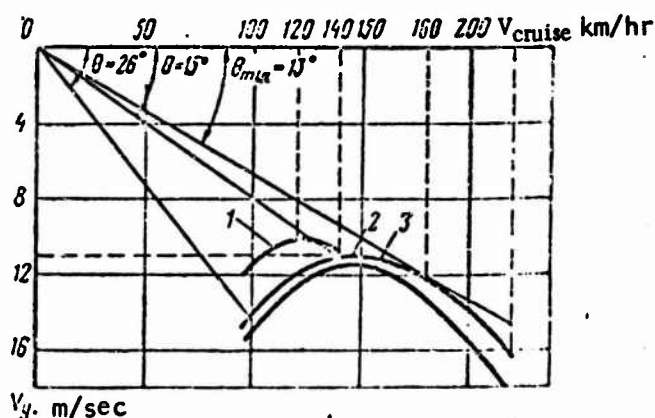

Figure 81. Vertical Rate of Descent and Glide Angles in Autorotation Mode of Lifting Rotor: 1, Unloaded helicopter; 2, Helicopter with normal flying weight and wing setting angle 5° ; 3, Helicopter with normal flying weight and wing setting angle 15° .

The recommended range of speeds is required for maneuvering in order to change the gliding range (forced landing in autorotation mode). The recommended forward speed for which the vertical descent speed will be least is the economical speed of horizontal flight, an indicated speed of 140 km/hr regardless of flying altitude.

Vertical descent rate. In aerodynamic calculation for the Mi-6 helicopter, the vertical speed is determined using the following formula:

$$V_y = V_{gl} \sin \theta.$$

The change in vertical descent speed as a function of forward speed in the autorotation mode under standard atmospheric conditions at an altitude of 1,000 m for the Mi-6 helicopter is shown on Figure 81. Curve 2 shows the change in vertical descent speed as a function of speed along the trajectory for a helicopter with normal flying weight with permissible rotating speed of the lifting rotor. As we can see from the curve, the minimum vertical descent speed will occur at the economical speed and will be 11 m/sec.

Curve 1 shows the change in vertical descent rate for the unloaded helicopter. As we can see from the curve, the minimum vertical speed will occur with an indicated forward speed of 120 km/hr and will be 10 m/sec. Consequently, 120 km/hr is the indicated economical speed for the empty helicopter, which does not contradict the general laws of aerodynamics: the less the weight of an aircraft (helicopter), the less the economical speed. Curve 3 shows the change in vertical speed of descent with a wing setting angle of 15° . As we can see from the figure, the vertical speed increases in comparison to its value with the setting angle of 5° only slightly: thus, at 140 km/hr, the change is only 0.5 m/sec. Consequently, in order to produce the minimum vertical speed during gliding and consequently the maximum gliding range from a given height, a forward speed of 140 km/hr should be retained. The rotating speed of the lifting rotor should not go beyond the permissible limits, depending on altitude and type of blades (see Table 6).

Glide Angle and Gliding Range

The glide angle of the helicopter is determined from the following formula

$$\theta = 57,3 \frac{V_y}{V_{gl}}.$$

There is considerable interest in the minimum glide angle, which gives us some idea of the gliding properties of the helicopter. According to the laws of aerodynamics, the minimum gliding angle and therefore the maximum gliding range should occur at the optimal speed of horizontal flight (gliding). Flying tests have established that the minimum gliding angle for the Mi-6 helicopter with normal flying weight is at 180 km/hr indicated and is 13° . If the speed is increased or decreased, the gliding angle will increase. For example, at 140 km/hr, it is 15° , at 100 km/hr-- 26° (see Figure 81).

The maximum gliding range is achieved at a speed of 180 km/hr

$$L_{max} = H \cot \theta_{min}$$

where H is the flying altitude.

Substituting the value of the minimum gliding angle into the formula, we produce the maximum gliding range under calm conditions

$$L_{max} = H \cot 13' = 4,331H,$$

i.e., the maximum range is 4.3 times the altitude. We can use these data to determine the aerodynamic quality of the helicopter. As we can see from the example presented, the maximum quality of the Mi-6 helicopter is somewhat more than 4, i.e., the gliding properties of the helicopter are not high. If we consider that the wing is not shifted to the low setting angle, the aerodynamic quality of the helicopter is even less.

The gliding range considering wind is determined from the following formula:

$$L = H \cot \theta \pm Ut,$$

where U is the wind speed;
t is the gliding time.

A nomogram has been constructed for the Mi-6 helicopter as a function of altitude, gliding speed (gliding angle), speed and direction of wind using the above formula as a result of flying tests for rapid determination of the gliding range, in order to avoid calculation using the formula (Figure 82). The range can be determined from this nomogram without difficulty, if the key is used.

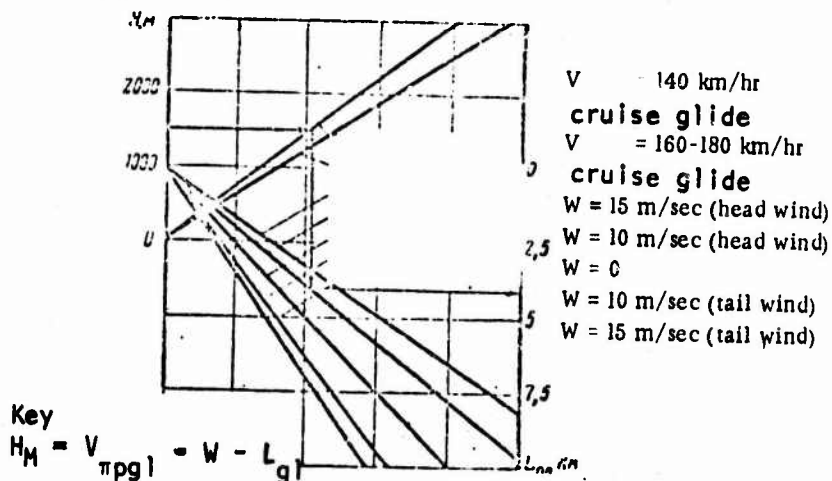

Figure 82. Nomogram for Determination of Gliding Range of Mi-6 Helicopter in Autorotation Mode.

In flying practice, particularly in case of an engine failure, the pilot not only does not have time to use the formula, but does not even have time to use the nomogram; therefore, he should memorize the basic range values at the speeds he uses as a function of altitude, direction and strength of wind. This requires that he use the nomogram to solve several problems for the most important cases of possible gliding and memorize the corresponding range values.

Specifics of Gliding Regime and Methods of Performance

When the helicopter is switched from the regime of flying with engine operating to the gliding regime, the pilot must set his speed within the permissible limits for the altitude (optimal indicated speed, regardless of altitude, 140 km/hr), decrease the general pitch to the minimum value (1° according to the indicator) regardless of altitude and rotate the gas corrector level to the left to put the engine in the idle regime ($15-17^\circ$ on the UPRT). If the rotating speed begins to increase to a level higher than the permissible speed for the altitude (see Table 6), the rotor must be made heavier.

Gliding with the engines choked is no different from gliding with the engines turned off or after engine failure. The difference is only that at altitudes over 1,500 m, the vertical speed is slightly decreased, since a higher general pitch will be required to maintain the rotating speed of the rotor, and an increase in general pitch causes an increase in UPRT reading (over $15-18^\circ$), i.e., some power will be transmitted to the rotor through the free turbine.

As the helicopter approaches the ground, the rotating speed of the lifting rotor will decrease, so that the general pitch of the lifting rotor must be decreased to maintain it within the required limits. The approximate value of general pitch was indicated above, but the lifting rotor speed indicator should be used as a guide. If the rotating speed is low, the general pitch must be decreased; if it is high, the general pitch must be increased. At altitudes of less than 1,000 m with the helicopter unloaded and with minimal pitch (1°), the rotating speed may go below the minimum permissible. In this case, the general pitch should not be increased, since the rotating speed may drop significantly.

When the helicopter is shifted to the autorotation mode, its balancing is disrupted; it turns to the right as a result of the lack of lifting rotor reactive moment, drops its nose and banks right. The helicopter can be balanced by deflecting the left pedal forward in order to decrease the thrust of the tail rotor and moving the control lever to the left in order to balance the thrust of the tail rotor. At the same time, the control lever should be moved back in order to prevent the diving moment which appears in all helicopters when the lifting rotor speed is decreased.

During gliding, turns can be made in any direction with bank angles up to 15°. The effectiveness of control for turns in autorotation is lower than when turns are made in flight with engines operating. A right turn will be made with the control levers in a position unfamiliar to the pilot, since the left pedal remains deflected forward. When a turn is begun, the rotating speed of the lifting rotor will increase with the same pitch, since the vertical speed increases, the conditions of autorotation improve, the rotor develops a higher speed and higher thrust. It is not recommended that the rotating speed be decreased by increasing the weight of the rotor.

When bringing the helicopter out of a turn, the rotating speed of the lifting rotor of the aircraft will return to its previous level.

If the wing is uncontrolled (i.e., cannot be shifted to the low setting angle), the vertical descent rate will be slightly increased. Furthermore, at speeds of over 200 km/hr, slight vibrations arise in the zone of the wing, the helicopter has a tendency to dive forward, so it must be held in the required position by moving the control lever back.

In order to shift a helicopter from the gliding regime to flight with engines operating, the general pitch lever must be moved upward smoothly to increase the operating mode of the engines to the required level, and the gas corrector knob must be used to set the required rotating speed of the lifting rotor for flight at the altitude of the helicopter. The helicopter will then become unbalanced. All control levers must be used (in the reverse order from that in which they were used when the helicopter was put into the autorotation mode) to balance the helicopter.

An engine failure cannot be imitated by moving the separate control lever downward, since high forces are required to move the general pitch lever downward, making it practically impossible, but if this is done, the separate control lever rises by itself.

527. Landing with Lifting Rotor in Autorotation Mode

Landing with the lifting rotor in the autorotation mode is used in case of engine failure, breakage of the tail rotor or transmission, main shaft or in case of a fire in the engine compartment, or for training purposes.

One method has been developed for landing the Mi-6 helicopter in the autorotation mode--using the general pitch lever, producing an obligatory landing run on the surface. We will analyze here a landing with engines turned off. recommended for training of flight personnel. Landing in the autorotation mode is performed without the navigator.

In order to perform this landing for training purposes, the helicopter is put in horizontal flight at 600 m altitude at a speed of 130-140 km/hr,

directed properly for the landing. After the command "prepare for landing with both engines off," the crew commander shifts the helicopter to the autorotation mode by rotating the gas corrector lever to the left and decreasing the general pitch of the rotor to the minimum (1°). When this is done, the rotating speed of the lifting rotor should be maximum, but not over 87%. A speed of 130-140 km/hr with normal flying weight or 120 km/hr with the helicopter empty should be maintained during the glide. With the economical gliding speed, the minimum vertical speed of descent is achieved and the gliding angle will be $15-18^\circ$. In this case, the landing is simple as concerns piloting techniques. Gliding speeds over the economical speed make piloting more difficult, increase the landing speed, landing distance and landing run length, and decrease flight safety. A prelanding glide speed of less than the economical speed will produce a high gliding angle, making piloting more difficult and flying more dangerous. The landing should be made against the wind or with a side wind of up to 5 m/sec.

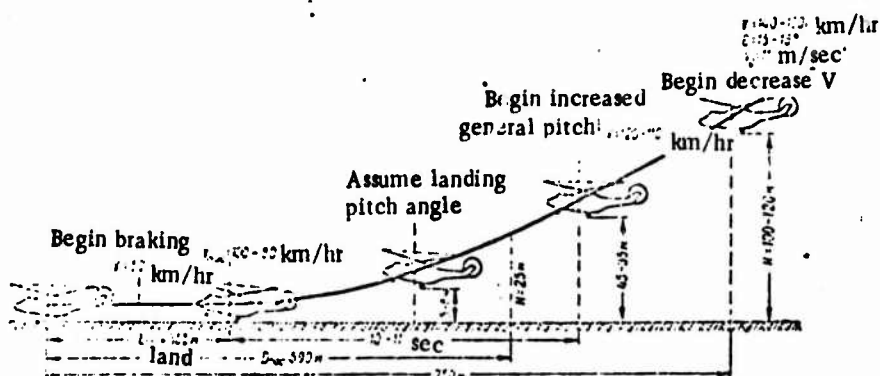

Figure 83. Profile and Elements of Landing of Mi-6 Helicopter in Autorotation Mode with Prelanding Glide Speed of 130-140 km/hr.

The actual landing operation is begun at an altitude of 100-120 m. At this altitude, the cyclical pitch lever is used to decrease the landing glide speed to 110-120 km/hr (Figure 83). This will result in an increase in the rotating speed of the lifting rotor by 1-2% and an increase in the pitch angle of the helicopter.

At 45-55 m altitude, the general pitch lever should be moved smoothly to increase the general pitch of the lifting rotor so that the general

pitch reaches the maximum at the moment of touchdown. This will decrease the vertical speed of descent and level out the flying trajectory of the helicopter. The time of movement of the general pitch lever from the beginning of the operation to touchdown is 10-11 sec.

Before the touchdown, the helicopter should be put in the landing position for a touchdown on the main wheels by deflecting the cyclical pitch lever forward. When landing with the limiting forward centering, since the pitch angle will be high, the cyclical pitch lever must be moved somewhat farther forward before the landing than with normal centering. Landing is performed on the main wheels, after which the helicopter rolls over until the front wheel touches down. The landing speed is 80-100 km/hr. After the landing, the general pitch must be rapidly decreased to the minimum value in 1.5-2 sec, in order to prevent a rapid decrease in the rotating speed of the lifting rotor. The brakes should be used in the second half of the landing run at speeds below 50 km/hr. The time of descent from 25 m altitude to touchdown is 10-11 sec.

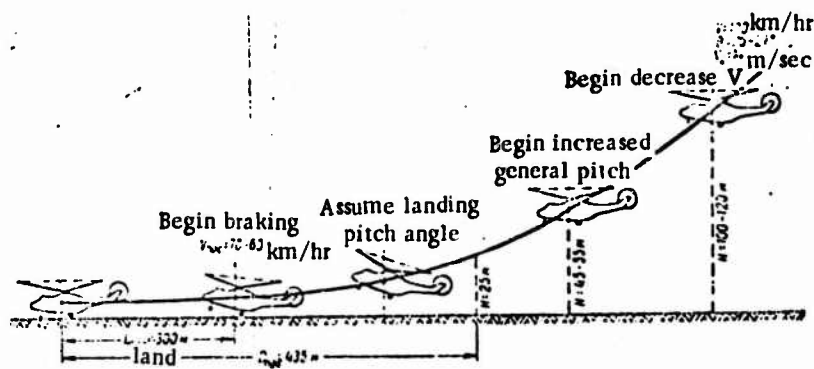

Figure 84. Profile and Elements of Landing of Mi-6 Helicopter in Autorotation Mode with Prelanding Glide Speed of 100 km/hr.

Landing in the autorotation mode with the helicopter unloaded differs little from landing in the helicopter at full flying weight. The difference is only that the prelanding glide speed must be held at 120 km/hr, and the cyclical pitch lever must be pushed forward further before the touchdown than when landing at the normal flying weight, i.e., the same as in the case of limiting rear centering of the helicopter.

In order to produce a lower landing run and landing distance in case of forced landing on a limited area or an area with high obstacles around it, the landing method is modified slightly from that described above. The prelanding glide speed should be 100 km/hr. In this case, the gliding trajectory will be steeper (26-27°), and the vertical descent speed will be 14 m/sec. Otherwise, the actions of the pilot are the same as in a landing at an ordinary heliport, but the landing must be performed more

carefully due to the difficult piloting techniques required. The landing speed should be 60-70 km/hr, the landing distance is 435 m, the landing run length 300 m. The profile and elements of this type of landing are shown on Figure 84.

The moment of thrust of the lifting rotor is a diving moment with forward centering and a nose up moment with rear centering, while the moments of longitudinal force and hub moment resulting from spread of horizontal hinges are nose up moments, while their summary moment--the lifting rotor moment--is always a diving moment in all flying regimes. The stabilizer moment is a nose up moment, the wing moment is a diving moment.

The longitudinal moment of the fuselage resulting from flow induced by the lifting rotor in the hovering mode may be considerable, while in other modes it is small and is not considered in calculation. This will be a nose up moment in all regimes; the longitudinal moment of the fuselage resulting from the flow on the nose will be a nose up moment only in the autorotation mode and a diving moment in all other flight modes. The summary moment of the fuselage will be a nose up moment in the autorotation mode, during hovering and at low flying speeds with the engines operating, and a diving moment in all other flying regimes.

During hovering, the moment produced by the wing as a result of air forced around the wing by the lifting rotor will be a nose up moment, in all other flying regimes it will be a diving moment.

The condition of longitudinal balancing of the helicopter is equality of nose up and diving moments, the sum of all longitudinal moments around the transverse axis should be equal to zero

$$\Sigma M_z = M_{z_{lr}} + M_{z_f} + M_{z_w} + M_{z_{st}} = 0.$$

In order to observe longitudinal balancing, it is also necessary that the sum of forces acting along the longitudinal axis of the helicopter be equal to zero. The condition of equality of forces was analyzed in our study of flying regimes; here we will only analyze equality of moments.

When flying in all regimes, longitudinal balancing of the helicopter is achieved by the corresponding deflection of the plate of the automatic swash plate using the cyclical pitch lever in the longitudinal direction. The limiting deflection of the plate of the automatic swash plate forward for helicopters with swash plate devices up to No. GV312001 is 6°42', for helicopters with swash plate device No. GV312001 and higher--7°18', and 4° and 5°36' back respectively.

Each flight speed corresponds to a strictly determined deflection of the automatic swash plate in the longitudinal direction, which also depends on the flying regime of the helicopter, the centering, the setting angle of the stabilizer, the rotating speed of the lifting rotor and the flying weight.

Limiting deflection of swash plate ring $5^{\circ}36'$ back

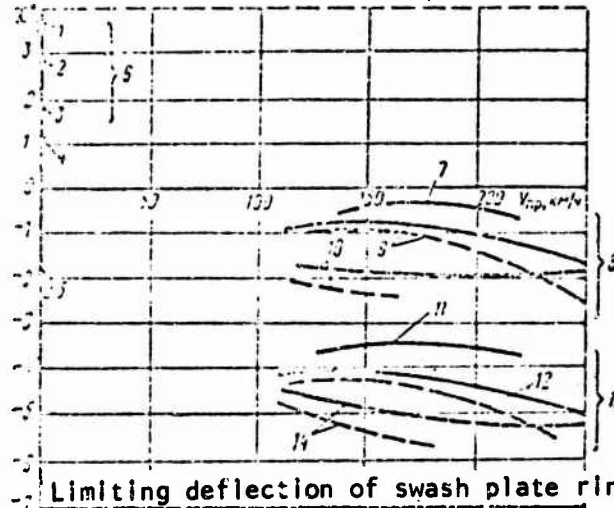

Limiting deflection of swash plate ring $7^{\circ}18'$ forward

Figure 86. Change in Required Angle of Deflection of Automatic Swash Plate in Longitudinal Direction for Mi-6 Helicopter as a Function of Speed and Flying Regime, Rotating Speed of Lifting Rotor and Centering of Helicopter. Solid line, $n_T = 8300$ rpm; Dotted line, $n_T = 7800$ rpm;

- 1, Maximum deflection during separation; 2, During separation; 3, Hovering; 4, Hovering, $X_T = 350$ mm, head wind;
- 5, Hovering, separation, landing with winds in various directions, $X_T = -220$ mm; 6, $X_T = 360$ mm (tail wind);
- 7, Autorotation; 8, $X_T = 360$ mm; 9, Horizontal flight;
- 10, Climbing; 11, Autorotation; 12, Horizontal flight;
- 13, $X_T = -200 - 220$ mm; 14, Climbing.

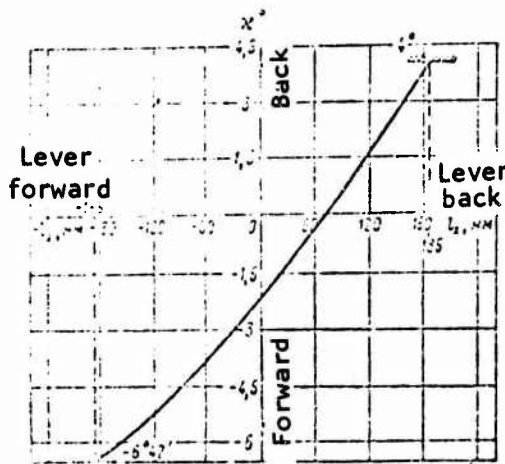

Figure 87. Interdependence of Angles of Deflection of Swash Plate and Travel of Cyclical Pitch Lever in the Longitudinal Direction.

Figure 86 shows the balancing curves for the required deflection of the automatic swash plate in the longitudinal direction as a function of flight speed with the two extreme values of centering: forward centering $X_T = 360$ mm and rear centering-- $X_T = -200 - 220$ mm for climbing at the nominal engine operating mode, horizontal flight and autorotation of the lifting rotor and for two rotating speeds of the free turbine: 7800 and 8300 rpm (78 and 83%). These balancing curves were constructed on the basis of the results of flying tests in the Mi-6 helicopter at normal flying weight at 300-800 m altitude.

As we can see from the curve, for horizontal flight at indicated speeds of 110-160 km/hr, the curves have no slope, i.e., at these speeds the same position of the automatic swash plate and cyclical pitch lever are required. In order to move more rapidly, the automatic swash plate and cyclical pitch lever must be moved forward. The curves also show that in order to make the transition from horizontal flight to a climb, the automatic swash plate and cyclical pitch lever must be tilted forward, since at high engine powers the stabilizer receives a higher flow of air from the lifting rotor and creates a higher nose up moment, which must be compensated by moving the control lever forward. In order to transfer from horizontal flight to the autorotation mode, on the other hand, the swash plate and control lever must be moved back, since diving moments predominate when the motor power is reduced, requiring that the lever be moved back to compensate for them.

The curves also show that with centering further forward, the automatic swash plate and control lever must be moved back, with centering further rearward--forward.

This is explained by the fact that when the center of gravity is displaced back, nose up moments begin to predominate, and when it is displaced forward--diving moments begin to predominate.

As the rotating speed of the lifting rotor increases, the tilt of the cone of rotation to the rear decreases due to the decreased flapping movements of the blades, diving moments appear, which must be balanced by deflecting the swash plate and cyclical pitch lever back.

The required deflection of the swash plate depends on the setting angle of the stabilizer as follows. In flight with engines operating, the higher the setting angle of the stabilizer, the less should be the deflection of the plate forward, and vice versa. This is explained by the fact that with high setting angles of the stabilizer, less nose up moment arises and, consequently, the movement of the swash plate forward should be less. In the autorotation mode, the opposite phenomenon is observed to flight with operating engines. The curves on the figure are given with consideration of the influence of the stabilizer, the

control of which is combined with control of the general pitch of the lifting rotor as follows: when the general pitch of the lifting rotor is increased, the setting angle of the stabilizer also is increased-- "the nose of the stabilizer follows the general pitch lever." With the maximum pitch (13.5°) the setting angle of the stabilizer is 5° (relative to the datum line of the helicopter), with the minimum pitch the setting angle of the stabilizer is 13° .

The controllable stabilizer thus decreases the required deflection of the swash plate in the longitudinal direction both in flights with engines operating and in the autorotation mode, and thereby increases the reserve of control. The controllable stabilizer expands the range of permissible centerings, acts as an aerodynamic trimmer, allowing the helicopter to be balanced over a broad range of pitch angles, required range of swash plate settings and cyclical pitch lever travel.

The influence of flying weight on the required deflection of the swash plate and the cyclical pitch lever in the longitudinal direction is not shown on the figure, but flying tests have established the following: the higher the weight of the helicopter, the more the swash plate and pitch lever must be moved forward. Thus, increasing the weight by 6-7 T causes a change in position of the swash plate by $0.5-1^\circ$, depending on flight speed: the higher the flight speed, the greater the forward deflection.

The minimum forward reserve of control will occur at the maximum speed of horizontal flight with limiting rear centering of the helicopter with $X_T = -200 - 220$ mm and the minimum permissible lifting rotor speed (7800 rpm), and also during a climb at about 200 km/hr. The reserve of longitudinal control in these operating modes in horizontal flight is 13.4% of one half the total travel of the lever, 17.2% for a climb.

The vertical axis of the graph shows the points of required deflection of the swash plate in the hovering mode with various orientations of the helicopter relative to a wind of 5-8 m/sec, and also when maneuvering under these conditions. The minimal control reserve for rearward movement will occur with limiting forward centering with a tail wind, but is quite sufficient.

Each position of the swash plate corresponds to a definite position of the cyclical pitch lever; the greater the deflection of the plate forward, the greater the lever must be deflected (Figure 87). As we can see from the figure, with the lever in the neutral position in the longitudinal direction, the swash plate is tilted $2^\circ 18'$ forward. This non-linearity in the longitudinal control is achieved in adjustment of longitudinal control and is done so that at moderate speeds (cruising speeds) with medium centering, the cyclical pitch lever will occupy a position

near neutral, which is most convenient for the pilot. At speeds below cruising speeds, the lever will be deflected back and its travel reserve will be sufficient even for hovering with a tail wind with limiting forward centering. With speeds over the cruising speeds, the lever will be deflected forward from the neutral position.

At each flying speed, the helicopter is balanced with a certain pitch angle: the higher the speed, the less the pitch angle and vice versa. Figure 88 shows the balancing curves for pitch angles of the Mi-6 helicopter in horizontal flight, in a climb and in the autorotation mode for all centerings $X_T = 350$ mm and $X_T = -220$ mm. We can see from the curves that the more the rear centering, the greater the pitch angle and vice versa.

The Mi-6 helicopter differs from the Mi-4 helicopter in that it has a greater range of pitch angle, as a result of the greater range of operational centering. For example, at the hovering mode, with rear centering $X_T = 200$ mm, the pitch angle reaches 8° , while when hovering with a tail wind it reaches -9° . When flying at the maximum speed of 250 km/hr with limiting forward centering, the pitch angle will be negative, about 6° .

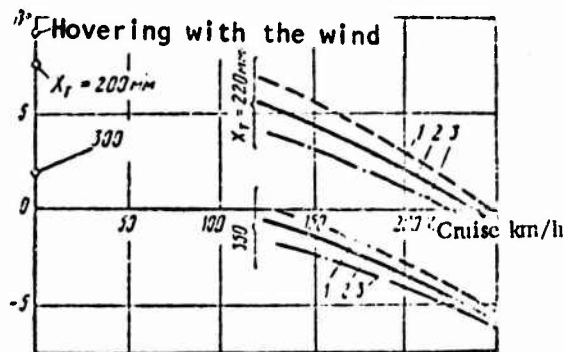

Figure 88. Change in Pitch Angles of Mi-6 Helicopter as a Function of Speed and Flying Mode, Longitudinal Centering: 1, Climb; 2, Horizontal flight; 3, Autorotation.

The longitudinal centering of the helicopter influences the longitudinal balancing and controllability, changing the required deflection of the swash plate and cyclical control lever in the longitudinal direction over broad limits. These deflections become great, particularly during hovering and at high flight speeds, and may cause insufficient control reserve for the desired flying mode, particularly if the permissible centerings are not observed. Longitudinal centering of the helicopter has great practical significance, since it changes as the helicopter is loaded.

Loading and Centering of the Helicopter

The centering of the helicopter is determined by the position of its center of gravity in the helicopters system of coordinates. For the Mi-6 helicopter, the point of intersection of the axis of the lifting rotor shaft with the plane of rotation is taken as the coordinate origin. The diagram of coordinate axis for determination of the centering of the Mi-6 helicopter is shown on Figure 89.

With all possible variants of loading of the helicopter, its center of gravity may shift over broad limits along longitudinal axis x , which influences the controllability and balancing of the helicopter significantly. On vertical axis y , the possibility of displacement of the center of gravity is slight and has almost no influence on controllability and balancing; therefore, it is not considered in practice. We will discuss transverse centering of the helicopter below.

The range of permissible operational longitudinal centerings is determined by the deflection of the swash plate in the longitudinal direction and therefore is strictly defined for each helicopter. On the basis of the arrangement of the helicopter, placement of equipment and all versions of loading, a limiting forward centering of $\chi_T = 0.36$ m, and a limiting aft centering of $\chi_T = -0.2$ m have been defined for the Mi-6 helicopter for all versions of loading; for the unloaded helicopter with full fuel tanks, $\chi_T = -0.22$ m.

In operating the helicopter, the limits of permissible operational longitudinal centerings must be strictly observed. If the centering goes beyond the permissible limits as the helicopter is loaded, the control reserve will be insufficient. Disruption of centering has a particularly bad influence on vertical flight modes and at high flight speeds (see Figure 86).

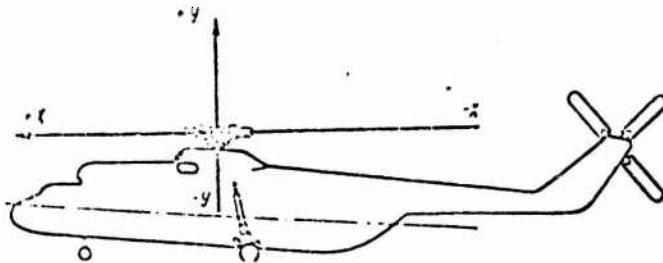

Figure 89. Diagram of Coordinate Axis for Calculation of Centering of Mi-6 Helicopter.

The permissible operational centerings of the Mi-6 helicopter are selected so that the control reserve will be sufficient for all flying modes, including hovering with a tail wind. A sufficient control reserve guarantees the possibility of safe piloting of the helicopter in all

flight modes, including bumpy air, which has been tested repeatedly by flying tests and by many years flying practice with the Mi-6 helicopter.

In order to observe the permissible operational centerings, the fuel tanks are placed in a definite manner within the helicopter, their order of filling and expenditure during flight have been established in a definite sequence. The fuel in the Mi-6 helicopter is placed in eleven soft rubber tanks located in the fuselage. Tanks 1-8 are located beneath the floor of the cargo cabin, tanks 9-10 and 11 are located behind the main reducing gear drive above the cargo cabin. The tanks of the fuel system are divided into five groups, each group having one filling throat. Also, the helicopter can carry nonjettisoned suspended tanks, the fuel in which is expended through group III. In order to increase the flying range, two more fuel tanks similar to the suspended tanks in design and capacity can be placed within the cargo cabin.

The distribution of tanks by groups, capacity and weight of fuel in groups are shown in Table 12.

TABLE 12. DISTRIBUTION OF FUEL TANKS BY GROUPS, CAPACITY AND WEIGHT OF FUEL IN TANK GROUPS

Number of Tank Group	Tank Numbers in Group	Capacity of Group of Tanks When Filled to Throat, l	Weight of Fuel in Group of Tanks, kg
I	2,3	940	725
II	4, 5, 6	1410	1100
III	7,8	870	675
IV	9,10	2700	2030
V	11	1760	1365
Reserve tank	1		
Suspended tanks (left and right)	—	470	360
Additional tanks (left and right)	—	4500	3490

The total capacity of fuel tanks, without the suspended and supplementary tanks, is 8150 l, with the suspended tanks--12,650 l, with the suspended and supplementary tanks--17,150 l, the corresponding weights being 6,315, 9,805, 13,295 kg.

A diagram of the placement of fuel tanks on the Mi-6 helicopter is shown on Figure 90.

In order to observe the range of permissible operational centering, the tanks must be filled in the order which is the reverse of the order of drainage of fuel when the automatic fuel sequencer is operating. Possible variants of filling of tanks of the Mi-6 helicopter with fuel are shown in Table 13.

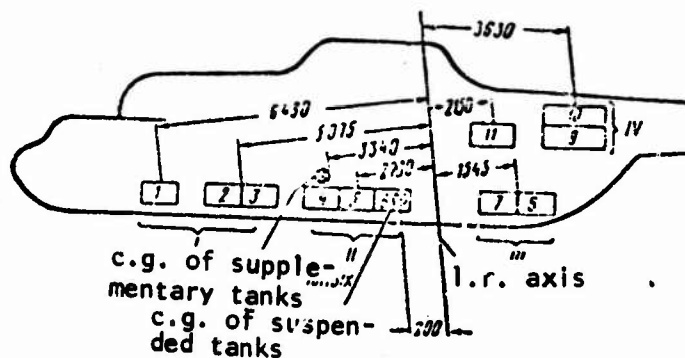

Figure 90. Diagram of Placement of Fuel Tanks on Mi-6 Helicopter.

When necessary, any quantity of fuel other than the quantity shown may be placed in each filling version, but in this case the next group of tanks in the filling order must be filled in completely. For example, if it is necessary to put a total of 4,000 kg of fuel in the helicopter, filling is performed as follows: 3,550 kg in group V, the reserve tank in group I and II, the remaining 450 kg in group III.

TABLE 13. FILLING VARIANTS OF MI-6 HELICOPTER FUEL TANKS

Filling Variant	Groups of Tanks						Quality of Fuel in Filling Version, kg		
	Supplementary tanks in cabin (3490 kg)	Suspended tanks (3100 kg)	IV (2000 kg)	III (675 kg)	II (1100 kg)	I (725 kg)	Reserve tank (500 kg)	V (1365 kg)	Total
1	---	Suspended tanks	IV	III	II	I	Reserve tank	V	9805
2	---	---	IV	III	II	I	Same	V	6315
3	---	---	---	III	II	I	•	V	4225
4	---	---	---	---	II	I	•	V	3550
5	---	---	---	---	---	I	•	V	2450
6	---	---	---	---	---	---	•	V	1725

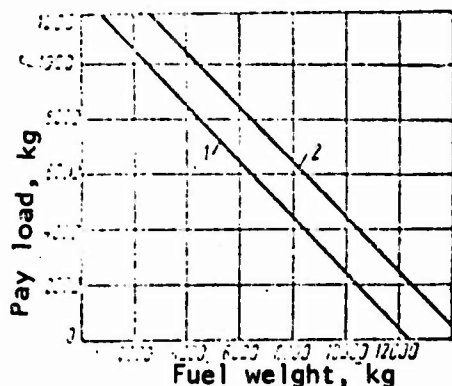

Figure 91. Graph for Determination of Maximum Payload as a Function of Fuel Reserve and Flying Weight of Helicopter: 1, Flying weight 40,500 kg; 2, Flying weight, 42,500 kg.

The weight of the payload depends on the quantity of fuel on the helicopter and its flying weight (Figure 91). The graph is constructed for an empty helicopter weighing 27,200 kg. If the weight of the helicopter is greater than or less than 27,200 kg, as used in the formula, an adjustment must be made to the payload produced by the graph. The graph is constructed without considering the weight of the additional and suspended tanks, so that if they are installed on the helicopter, the payload must be decreased by 227 kg, and when the supplementary tanks are placed inside the cabin--by 378 kg. For the Mi-6 helicopter, the weight of the crew (five persons) is 400 kg, the weight of oil--280 kg, the weight of alcohol carried for the deicing system of the tail rotor is 25 kg.

In order to achieve permissible operational centerings throughout the entire range of a flight, the cargo in the cabin must be placed using the scale on the right wall of the cargo cabin. Cargo can be placed in the cabin so that the overall center of gravity lies between the blue arrow corresponding to the cargo carried located forward and the yellow common arrow for all cargoes located near the tail portion of the fuselage. It is recommended that cargoes be placed so that their center of gravity is between the blue and red arrows corresponding to the cargo carried.

To assure minimum change of centering as the fuel is burned during the flight, and to assure that the centering does not go beyond the permissible limits, the following automatic sequence of fuel expenditure from tank groups is established (Table 14).

TABLE 14. SEQUENCE OF FUEL EXPENDITURE FROM TANK GROUPS OF MI-6 HELICOPTER

Sequence of Expenditure	Number of Tank Group	Pumps of Group in Use	Note
1	IV	IV	
2	V	V	150-200 kg expended until floating valve opens
3	Suspended tanks	V, III	
4	III	V, III	
5	II	V, II	
6	I	V, I	
7	V	V	Until "800 kg remaining" lamp lights
8	Reserve tank	V, Reserve tank	
9	V	V	

Table 14 shows the sequence of expenditure of fuel from groups of tanks without filling the supplementary tanks installed within the cargo cabin of the helicopter. If the supplementary tanks are filled, fuel is expended in the following sequence. The fuel expenditure is switched to manual control. The pump of group IV is turned on and 200 kg of fuel are expended. Then the pumps of groups IV and V and the on-board fuel filler are turned on and the fuel is expended from the supplementary tanks. After fuel is expended from these tanks, the pump of the on-board fuel filler system is turned off. The control switch is put in the automatic position, and further fuel expenditure occurs in the sequence shown in Table 14.

If the automatic fuel sequencer fails, the flight engineer switches to manual control and follows the same sequence, using a special table carried in the cockpit. In case the fuel system is incompletely filled, the sequence of fuel expenditure is still retained.

If the sequence of fuel expenditure is observed, as shown in Table 14, and the cargo is placed according to the guide in the cargo cabin, the centering of the helicopter will remain within the permissible limits during all stages of flight, and will change as the fuel is burned as is shown on Figure 92. Figure 92 shows six versions of cargo loading and fuel filling. Curves 1, 2 and 3 show the change in centering in flight due to burning of fuel when only the main eleven fuel tanks are filled (6,315 kg) but with varying placement of the center of gravity of the cargo: 1, cargo placed next to blue arrow; 2, next to red arrow and 3, next to yellow arrow on right wall of cargo cabin. As we can see from curve 1, the centering will be near the limiting forward centering of 360 mm after fuel is burned from group III of tanks. In this version of loading and filling the centering at takeoff will be 100 mm, at landing about 200 mm forward of the lifting rotor shaft axis. If the cargo is placed next to the red arrow (curve 2), the nature of the change in centering as the fuel is burned will be the same as in the preceding case, except the centering will be further rearward: during takeoff it will be zero, at landing about 100 mm forward of the rotor shaft. If the center of gravity of the cargo is placed next to the yellow arrow, the centering will be even further aft: about 160 mm at takeoff, about 130 mm at landing (curve 3).

The graph also shows curves of the change in centering as a function of fuel expenditure for a helicopter without cargo, but with three different filling versions: 4, only main tanks filled (6,315 kg); 5, Main tanks and suspended tanks filled (9,805 kg); 6, Main, suspended and supplementary tanks all filled (13,295 kg). As we can see from curve 4, in the helicopter without cargo with the main fuel tanks filled, the centering in flight changes the same way as with cargo, the center of gravity of which is placed next to the yellow arrow. When the main and suspended tanks are filled (curve 5) at takeoff with the unloaded helicopter the centering will be near the limiting permissible rear centering,

then will move forward; as the fuel is burned from the suspended tanks the centering changes only slightly, since the center of gravity of these tanks is located near the center of gravity of the empty helicopter. Then, after the fuel from the suspended tanks is burned, the centering will change as in the case of curve 4.

With full, main, suspended and supplementary tanks in the unloaded helicopter (curve 6) at takeoff the centering will be about +200 mm, then as the fuel is burned from the supplementary tanks it will decrease, i.e., approach rear centering, since the center of gravity of the supplementary tanks is located forward of the center of gravity of the helicopter. After the fuel is burned from the supplementary tanks, the centering will change as in the case of curve 5. Here curve 6 does not correspond with curve 5, since before beginning to burn fuel from the supplementary tanks, 200 kg of fuel must be expended from the tanks of group IV.

Thus, with proper placement of cargoes according to the marks inside the cabin and with the automatic sequence of fuel expenditure, the pilot can know his centering at takeoff, in flight and during the landing. If for some reason (cargo size) it is impossible to place the cargo according to the marks, the cargo must be oriented relative to the first rib, and the centering at takeoff, limiting forward and limiting rear centering during flight resulting from burning of fuel must be determined using a special centering graph, and if the centerings produced do not go beyond the permissible limit, the loading of the helicopter has been performed properly and takeoff can be permitted.

During flight, the limiting forward centering may occur only after expenditure of fuel from group III of tanks and switching to group II (see Figure 92). In this case, groups I, II and V and tank No. 1 should be completely full, amounting to 3,550 kg of fuel with a specific gravity of 0.775 kg/l. The limiting rear centering with main tanks incompletely filled will occur at the moment expenditure of the fuel from tank 1 is completed, when fuel expenditure is shifted to the fuel remainder of 820 kg in group V.

Before takeoff, the centering graph is used to determine the takeoff centering, based on knowledge of the takeoff weight, cargo carried and fuel carried at takeoff, the limiting forward centering during flight is determined based on knowledge of the fuel remainder at this time and the flying weight, and the limiting aft centering is determined based on knowledge of the fuel remainder and flying weight at the time. If anyone of the three centerings goes beyond the permissible limits, the cargo must be moved and the centering recalculated, this process continuing until all three centerings are within the permissible limits.

The centering graph for the Mi-6 helicopter is similar to the centering graphs for other helicopters; therefore, we will not present it here.

NOT REPRODUCIBLE

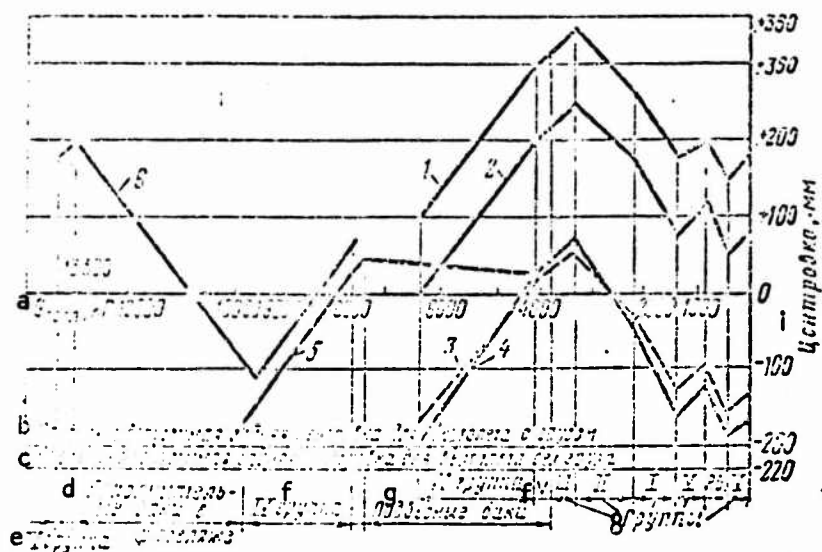

Figure 92. Graph of Change in Centering of Mi-6 Helicopter in Flight as a Function of Fuel Expenditure: 1,2,3--Helicopter with cargo; 4,5,6--Helicopter without cargo.

Key: a, G_{fuel} , kg; b, Limiting permissible rear centering for helicopter with cargo; c, Limiting permissible rear centering for helicopter without cargo; d, Additional tanks in fuselage; e, Group V; f, Group IV; g, Suspended tanks; h, Groups; i, Centering, mm.

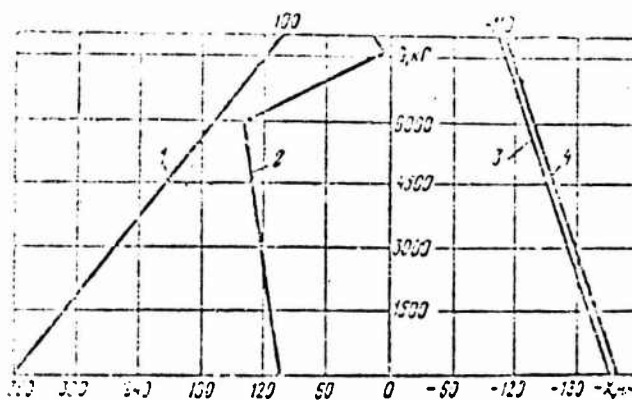

Figure 93. Graph of Permissible and Operational Centerings of Mi-6 Helicopter as a Function of Cargo Weight Suspended Externally.

NOT REPRODUCIBLE

When cargo is transported on the external hook alone, the order of fuel expenditure remains the same as when cargo is carried inside the cabin, and the centering will not go beyond the permissible limits, since the hook suspension system is located near the center of gravity of the helicopter. The maximum flying weight of the helicopter in this case should not be over 38 T, the maximum weight of cargo on the suspended hook not over 8 T. The greater the weight of cargo on the external hook, the less the range of permissible centerings. For example, when cargoes are carried within the cabin, the limiting forward centering is +360 mm, the limiting aft centering is -220 mm, but with increasing weight of externally suspended cargo this range decreases, until with a weight of 8 T suspended externally the limiting forward centering should be +100 mm, the limiting aft centering -110 mm. The change in permissible centerings as a function of cargo suspended externally is shown on Figure 93 (curves 1, 4). This same figure shows the operational centering as a function of cargo weight on the hub (curves 2, 3).

Simultaneous transport of cargo suspended externally and cargo within the cabin is permitted, although in this case the flying weight of the helicopter should not exceed 38 T, as when cargo is carried on the external hook alone. The order of fuel consumption remains the same as when cargo is transported inside the cabin. In order to assure centering within the permissible limits, the cargo within the cabin must be placed so that the center of gravity does not go beyond the limits of the coordinates shown on Table 15.

TABLE 15. COORDINATES OF CENTER OF GRAVITY OF CARGO WITHIN CABIN WHEN CARGO IS ALSO CARRIED ON HOOK

Weight of Cargo in Cabin, kg	Permissible Position of Cargo c.g. Within Cabin, m			
	Weight of Cargo on Extended Hook, kg			
	0-2000	2001-4000	4001-6000	6001-8000
0-2000	3,140	1,859	0,509	0,1
2001-4000	1,715	1,057	0,334	—
4001-6000	1,240	0,780	—	—
6001-8000	1,003	—	—	—
0-8000	-0,190	-0,160	-0,130	-0,110

Note. Plus sign indicates permissible placement of cg of cargo with cabin forward of lifting rotor shaft, minus sign--aft of lifting rotor shaft.

This table should be used as follows. For example, a cargo of 5,000 kg is carried on the hook, with 3,000 kg inside the cabin. At the point where the vertical column for 4,001-6,000 "meet the horizontal line 2,001-4,000," we read the number 0.334 m, which is the permissible position of the center of gravity of the cargo within the cabin forward of the lifting rotor shaft. At the bottom of the column we rear: -0.130 m,

which is the permissible position of the center of gravity of the cargo within the cabin aft of the axis of the lifting rotor shaft.

The centering of the Mi-6 helicopter in the transverse direction is generally not calculated. However, the cargo should be placed symmetrically in the helicopter on the transverse axis. If the size of the cargo does not allow it to be placed symmetrically, in order to assure a sufficient transverse control reserve the transverse moment resulting from asymmetrical placement of the cargo should not exceed 4,000 kg. The arm of the moment is from the axis of symmetry to the center of gravity of the cargo.

In the hovering mode with no pressure on the cyclical pitch lever, the pilot can determine the centering according to the indications of the longitudinal and transverse trimmers: the longitudinal trimmer should be -0.5-1 division to the rear, the transverse trimmer--0.5-1.5 divisions to the right.

Transverse Balancing

In order to explain the conditions of transverse balancing, let us analyze the transverse moments acting on the Mi-6 helicopter around longitudinal axis X and the forces on the transverse axis.

The helicopter can be balanced in the transverse axis without slip, but always with a right bank (Figure 94a) or with no bank, but with a left slip (Figure 94b).

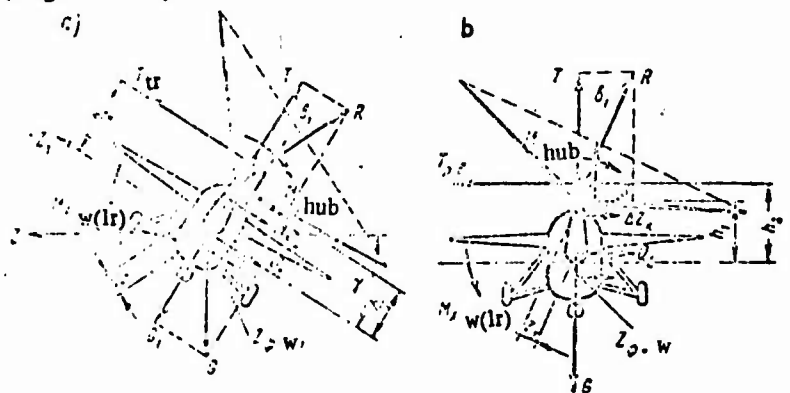

Figure 94. Transverse Balancing of the Mi-6 Helicopter.

The following transverse moments act on the Mi-6 helicopter: the moment of the tail rotor ($T_{tr} h_2$), the moment of the fuselage and wing resulting from the oncoming air flow ($M_{x_{f+w}}$), the moment of the wing resulting from the blast from the lifting rotor (M_{x_w}), the moment of the lifting rotor, consisting of the side force moment and the hub moment

resulting from the spread of the horizontal hinges ($M_{xw(lr)}$) and the transverse moment from the keel resulting from the influence of the tail rotor.

In order to fly without slip, it is necessary that the side forces be balanced, i.e., that

$$S \cdot \Delta Z_b \cdot Z_{f+w} = T_{tr}$$

but in order to create the side force S , it is necessary that the aerodynamic force of the lifting rotor, along with the cone of rotation, be deflected to the right; then the inertial moment of the hub resulting from the spread of the horizontal hinges (M_{x_h}) appears. However, trans-

verse balancing requires equality of moments as well: $M_{x_{tr}} + M_{x_{f+w}} + \Delta M_{x_{w(lr)}} = M_{x_{lr}} + M_{x_k}$. This condition is fulfilled only with a right bank, since the arms of the side forces h_1 and h_2 are almost equal, while the inertial moment of the hub resulting from spread of the horizontal hinges acts to the right (M_{x_h}), causing a right bank. This bank results in weight component G_2 , equal to $G \sin \gamma$. Only in this case will equality of side forces on the transverse axis be observed

$$T_{tr} = S \cdot \Delta Z_b \cdot Z_{f+w} = G_2 \cdot Z_{f+w}$$

For the Mi-6 helicopter when hovering, the right bank is over 2° . As the speed of horizontal flight increases to the economical speed, the bank decreases due to the decrease in hub moment M_{x_h} , while the required power decreases, so that the reactive moment of the lifting rotor decreases, so that the required thrust of the tail rotor decreases and the shifting of the cone to the right should decrease (Figure 95, curve 2). At the economical speed, the bank is $0^\circ 45'$. With further increase in speed, the bank increases once more, since the required power increases. Therefore, the reactive moment of the lifting rotor and required thrust of the tail rotor increase, requiring a greater shift of the cone to the right to balance the force, which leads to an increase in the bank to the right. Figure 95 also shows curves of the change in bank angle as a function of speed in the horizontal flight mode, in ρ climb and in the autorotation mode. In the climbing mode, the right bank is greater than in horizontal flight at all speeds, since the power of the lifting rotor is greater, its reactive moment is greater, and therefore more thrust of the tail rotor and more side force are required. This demands a greater shift of

the cone of rotation to the right, which increases the hub moment resulting from the spread of the horizontal hinges. In the autorotation mode, the helicopter has a slight left bank, since the cone shifts to the left and the hub moment is directed to the left (see Figure 80).

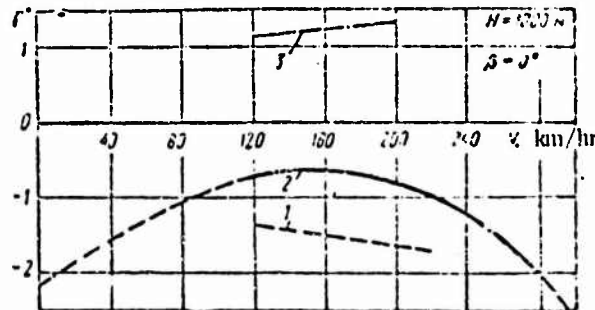

Figure 95. Change in Bank Angle During Flight of Mi-6 Helicopter Without Slip: 1, During climb; 2, In horizontal flight; 3, In autorotation mode.

In order to achieve transverse balancing of the helicopter without a bank, the transverse moments about the longitudinal axis must be balanced with no bank (see Figure 94b). In order for there to be no bank, side force S must be decreased by deflecting the cone and force R of the rotor to the left, using the cyclical pitch lever. Now the side forces will be unbalanced, i.e., T_{tr} will be greater than the sum of forces:

$$S + \Delta Z_k + Z_{f+w}$$

which will result in a less slip, the air flow around the helicopter will be from the front and the left at slip angle β . In stable flight, there should be equality of moments around longitudinal axis X and equality of forces around transverse axis Z . The inclined flow around the helicopter from the left causes a side force on the fuselage Q_z , which balances the unbalanced forces. Now the sum of all forces on the Z axis will be zero. In this case, side force Q_z is applied almost at the center of gravity and creates no additional moment. With increasing flight speed, side force Q_z will increase, and in order to observe transverse balancing, the slip angle must decrease, leading to a decrease in side force Q_z , i.e., retaining it unchanged.

In analyzing transverse balancing, we must explain the nature of appearance of transverse force on the keel due to the influence of the tail rotor ΔZ_k and the transverse moment of the wing resulting from flow around the wing produced by the lifting rotor.

Since the tail rotor is installed to the right of the keel beam, and the air flow through the rotor moves from left to right, the flow approaching the keel resulting from the forward flight speed is moved from left to right by the inductive flow of the tail rotor. As a result, an angle of attack is created and an additional aerodynamic force ΔZ_k arises on the keel due to the influence of the tail rotor. It is directed from left to right, applied to the center of pressure of the keel and creates transverse moment ΔM_{x_k} , directed to the right, as well as a track moment of considerable magnitude acting in the direction of the reactive moment of the lifting rotor.

During wind tunnel tests of a model of the Mi-6 helicopter with wing and operating rotor, it was established that the lifting rotor induces an uneven flow over the span of the wing. In forward flight, the left wing is more intensively blown than the right wing, creating a left banking moment of the wing $\Delta M_{xw(lr)}$. In order to decrease the influence of this moment, the designers used degradation of the setting angles of the left and right wings by 1.5° . Subsequently, as a result of flying tests, a clear insufficiency of transverse control reserve to the left at high flying speeds was noted. In order to increase this reserve, the designer had to remove the degradation of setting angles of the left and right wings and utilize the reverse difference, i.e., the right wing currently has setting angles 1.5° greater than the left wing.

In order to assure transverse balancing of the helicopter in all flying modes, both with and without slip, a certain deflection of the swash plate in the transverse direction must be used. In all versions of the Mi-6 helicopter, the limiting transverse deflection to the right is $3^\circ 54' \pm 12'$, to the left-- $5^\circ 24' \pm 12'$.

The limiting deflection of the swash plate to the left is $5^\circ 24'$, to the right-- $3^\circ 54' \pm 12'$.

Figure 96 shows balancing curves of required deflection of the swash plate of the Mi-6 helicopter in the transverse direction. The balancing angles of deflection of the swash plate as a function of flight speed throughout the entire range of longitudinal centerings and for flying modes with symmetrical transverse centering of the helicopter are located in the shaded zone of the graph, limited by the two straight lines. Two dotted lines are also shown, indicating the required deflection of the swash plate in the transverse direction with fully loaded right or left suspended fuel tanks. As we can see, the difference in required swash plate deflection with limiting right and limiting left centering is about 2° .

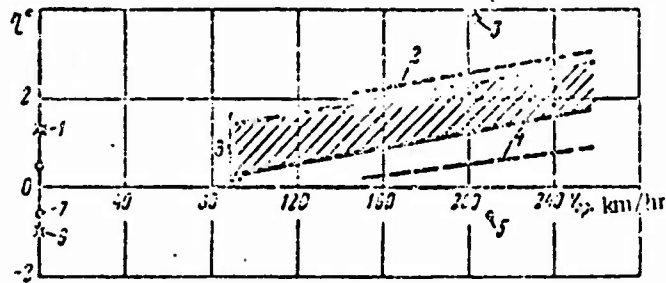

Figure 96. Required Deflection of Swash Plate in Transverse Direction as a Function of Flight Speed, Centering and Flying Modes: 1, Maximum deflection when hovering with right suspended tank; 2, With right suspended tank, $X_T = 80$ mm; 3, Maximum deflection with left slip with right suspended tank, $X_T = 80$ mm; 4, With left suspended tank, $X_T = 80$ mm; 5, Maximum deflection with right slip with left suspended tank, $X_T = 80$ mm; 6, Maximum deflection during hovering with left suspended tank; 7, Hovering near the ground, takeoff and landing at $W = 5$ m/sec in various directions, $X_T = 350$ mm; 8, All modes with symmetrical transverse loading.

We can see from the curves that as the flight speed increases, the swash plate must be deflected, and therefore the cyclical pitch lever must be moved from right to left. The greatest deflection of the plate to the left is 3° , produced at 260 km/hr when flying with the right suspended tank full. At this speed, the minimum reserve of transverse control is produced, but it is 50.8% of one half the full transverse travel of the swash plate.

The graph shows points indicating the deflection of the plate to the right and left with slip at the limiting lateral centerings, which do not exceed 4° left, 1° right.

On the coordinate axis, the white circles represent values of deflection of the swash plate for vertical flight, landing and hovering, as well as maneuvering while hovering with limiting forward centering and winds up to 5 m/sec in various directions. The black circles show the values of limiting deflection of the swash plate with limiting transverse centerings, i.e., with only the right or only the left suspended tank filled. As we can see, even at these modes, the reserve of transverse control in the Mi-6 helicopter is quite sufficient.

Figure 97 shows the interrelationship between deflection of the swash plate and travel of the cyclical pitch lever in the transverse direction. As we can see from the figure, with the neutral position of the cyclical pitch lever, the swash plate is tilted to the left by 1.5° . This non-linearity in transverse control is achieved in adjustment and is required so that at cruising speeds the cyclical pitch lever is near the neutral position in the transverse direction.

NOT REPRODUCIBLE

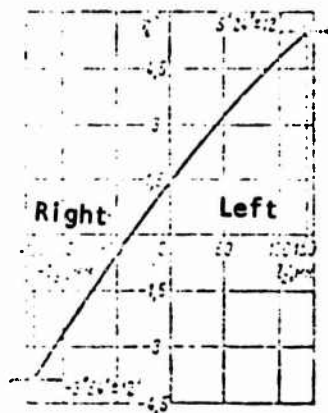

Figure 97. Interrelationship of Cyclical Pitch Lever and Swash Plate Deflection in Mi-6 Helicopter.

Then, at speeds less than cruising speeds it will occupy a position to the right of the neutral position, and at speeds above the cruising speed it will be deflected to the left.

Track Balancing

In order to analyze track balancing, let us look at the track moments acting on the helicopter. As was established above, side balancing will be achieved with a right bank but without slip or with no bank but with left slip. The conditions of transverse balancing in these two cases were discussed earlier; now let us analyze the conditions of track balancing in flight with bank and flight with slip.

Figure 98a shows the forces and track moments acting on the helicopter in flight without slip, while Figure 98b shows the forces and track moments acting on the helicopter in flight with left slip. The Mi-6 helicopter when flying without slip is acted upon by the following track moments: the tail rotor moment $M_{y_{tr}}$,

$M_{y_{lr}}$, the track moment of the fuselage and wing due to the oncoming air flow $M_{y_{f+w}}$ and the track moment of the keel resulting from the influence of the tail rotor ΔM_{y_k} (Figure 98a).

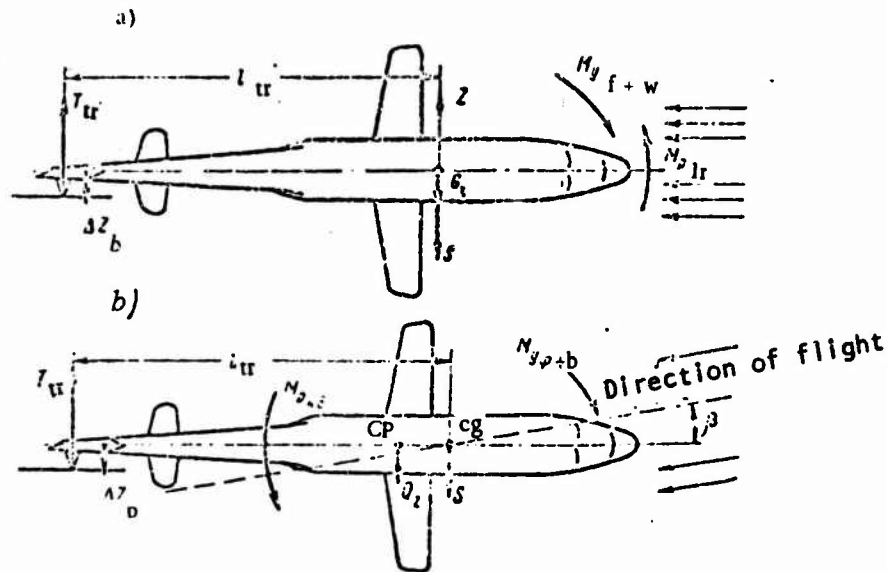

Figure 98. Track Moments Acting on Mi-6 Helicopter:
 a, Flight without slip; b, Flight with left slip.

The track moment of the fuselage and wing resulting from the oncoming air flow $M_{y_{f+w}}$ also includes the track moment created due to the profile of the fixed tip beam rudder. As we know, the fixed rudder of the tip beam is shaped so that in forward flight it creates a lift directed to the left, in the direction of the effect of the thrust of the tail rotor in flight with the engines operating, thus unloading the tail rotor, particularly at high speeds.

Track balancing of the helicopter in flight without slip is provided by equality of moments acting about the vertical axis

$$M_{y_{lr}} + \Delta M_{y_t} = M_{y_{lr}} + M_{y_{f+w}}$$

Since in various flight modes with various speeds, various levels of power are required for flight, producing various reactive moments of the lifting rotor, with a constant arm length for the thrust of the tail rotor, track balancing requires varying thrust of the tail rotor, achieved by changing the setting angles of the tail rotor blades--the pitch of the blades.

Track balancing of the Mi-6 helicopter with left slip is provided by equality of moments (see Figure 98b):

$$M_{y_{lr}} + \Delta M_{y_t} + Q_2 l_1 = M_{y_{lr}} + M_{y_{f+w}}$$

As we can see, when flying with left slip the tail rotor moment must also balance the track moment resulting from side force Q_2 , so that the thrust

of the tail rotor when flying with slip must be greater than when flying without slip. In order to increase this thrust, it is necessary to increase the pitch of the tail rotor by moving the right pedal forward (particularly at low speeds, where the slip is greater). The left slip increases the tilt of the cone of rotation to the right. In order to produce the left slip and decrease the tilt of the cone of rotation to the right, the tilt of the swash plate and cyclical pitch lever must be moved to the left. In order to balance the additional lateral force Q_z and create greater thrust of the tail rotor, higher power is required, leading to an increase in fuel consumption.

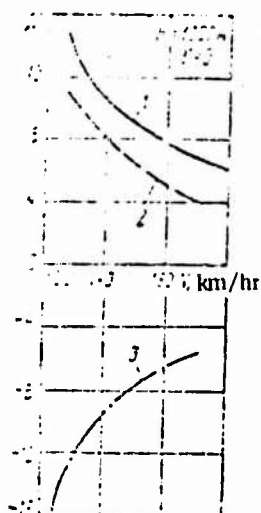

Figure 99. Change in Slip Angle as a Function of Speed When Flying Without Bank at 1,000 m: 1, Climb; 2, Horizontal flight; 3, Autorotation.

Flying without the right bank with slip causes the helicopter to move off to the left at the slip angle, which is called the aerodynamic drift angle UC_{aer} . As the flight speed increases, this angle decreases, since side force Q_z increases (see Figure 98b) requiring greater deflection of the cone of rotation to the right by the cyclical pitch lever; in this case, side force S increases when there is no bank and the slip to the left decreases.

The change in the slip angle (aerodynamic drift angle) as a function of flight speed during a climb, horizontal flight and during autorotation in the Mi-6 helicopter is shown on Figure 99, the curves being produced as a result of aerodynamic calculation. As we can see from curve 2 at a speed of 100 km/hr in the horizontal flight mode, the drift angle is somewhat over 12° , decreasing with increasing speed until at 200 km/hr it is 4° . Flying tests have indicated that the drift angle is somewhat less than the calculated values. During their climb, the angle of slip is greater, since during a climb without slip the angle of right bank is greater than in horizontal flight. In order for the bank angle to be decreased to zero, more left slip is required than in horizontal flight

(see Figure 95). In the autorotation mode, flight without bank requires right slip, since the bank during autorotation is to the left. In order to eliminate it, a right slip must therefore be created. With increasing flight speed, the slip angle decreases for the same reasons as obtained during flights with the engine operating.

It is practically impossible to fly without bank with these small slip angles, just as it is impossible to perform flights without slip with small bank angles. Flight is usually performed either without bank, or with right bank without slip, or sometimes with right bank greater than that indicated, producing right slip or with a left bank, producing a drift angle higher than when flying without bank. Naturally, all of this results in additional course errors, in addition to those produced for other reasons. It is not a good idea to attempt to consider the aerodynamic drift angle in performing navigational calculations either for visual or for instrument flight.

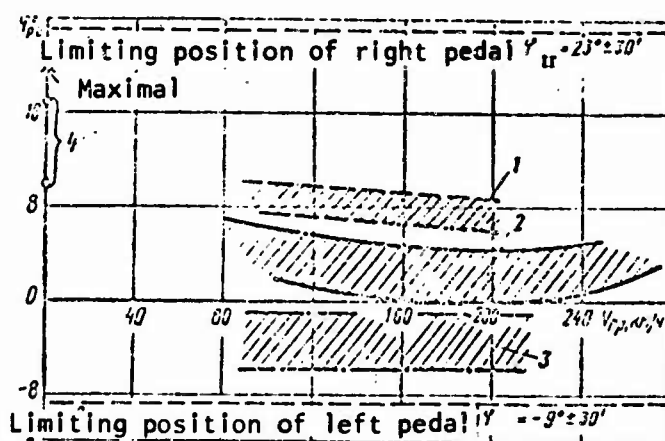

Figure 100. Change in Required Tail Rotor Pitch for Track Balancing as a Function of Speed and Flying Mode: 1, Climb; 2, Horizontal flight; 3, Autorotation of lifting rotor; 4, Hover and maneuvers while hovering with winds in various directions at 5-8 m/sec.

The range of change of pitch of the tail rotor, is designed to provide for track balancing of the Mi-6 helicopter in all flying modes at all speeds. The AV-63-Kh6 tail rotor will have maximum pitch with full right pedal deflection of $-23^{\circ} \pm 30'$, with full left pedal deflection $-9^{\circ} \pm 30'$.

Figure 100 shows the balancing curves of the dependence of required tail rotor pitch on flight speeds for all modes. The required tail rotor pitch for each flight mode may differ, depending on the amount of slip, bank angle and engine power. The balancing curves produced in flight tests for each flight mode (horizontal--solid line, climb--dotted line, autorotation--dot-dash line) are shown by the shaded zones on the figure.

As we can see from the graph, all flying modes with engines operating require positive tail rotor pitch, or negative tail rotor pitch in the autorotation mode, in order to direct its thrust to the right. In all horizontal flight modes, as the speed is increased, the required tail rotor pitch is reduced. The decrease in tail rotor pitch required up to the economical speed is explained by the fact that a required power of the lifting rotor and therefore its reactive moment are decreased, requiring therefore less track moment of the tail rotor. At speeds from 140 to 175 km/hr, the power of the lifting rotor increases and its reactive moment therefore also increases, but the tail rotor continues to increase its thrust due to the slanted flow and the thrust is greater than the required thrust. Therefore, the pitch must be decreased by moving the left pedal forward. Only at speeds of over 170 km/hr, as a result of increasing power of the lifting rotor and worsening conditions of operation of the tail rotor must the pitch be increased by moving the right pedal forward.

A climb requires a higher pitch of the tail rotor than horizontal flight, since the required power increases. In the autorotation mode, the required pitch of the tail rotor does not change as a function of flight speed.

The highest positive value of general pitch of the tail rotor should occur in the hovering mode and when maneuvering (particularly with a wind) and may reach 17°, with a highest, so-called peak value of up to 20°. The minimum pitch is observed in the autorotation mode, and is up to -6°.

The required tail rotor pitch in flight with engines operating changes as follows as a function of lifting rotor speeds: the lower the speed of the lifting rotor, the greater the required pitch, since the reactive moment of the tail rotor is inversely proportional to the rotating speed

$$M_{P_{1,r}} = 716.2 \frac{N_{1,r}}{n_{1,r}} .$$

Also, a decrease in the rotating speed of the lifting rotor leads to a decrease in the rotating speed of the tail rotor and in its thrust. This is particularly true in the hovering mode, when the lifting rotor has high reactive moment; the pedal will then be deflected forward more fully. If a lower rotating speed is achieved with the same power level, the moment may be increased to the extent that the full right pedal travel will be insufficient to prevent the helicopter from turning to the left, which particularly occurs at heliports located at high elevation.

Figure 101 shows the interrelationship between the change in tail rotor pitch and pedal travel of the foot pedals. As in the longitudinal and transverse control systems, nonlinear transmission is used, so that

with the pedals near the neutral position the pitch of the tail rotor is about 4° , corresponding to the pitch required for horizontal flight at the cruising speed of about 200 km/hr indicated. This makes piloting the helicopter more convenient.

§29. Controllability and Stability of the Helicopter

Controllability

One distinguishing feature of the control of the Mi-6 helicopter is the fact that all control levers must be used in all flying modes, since deflection of one lever causes the helicopter to become unbalanced and rotate around all three axes. In order to go into a vertical climb from the hovering mode, the "pitch-gas" lever must be moved upward. The helicopter will begin to climb with a simultaneous left turn due to the increased reactive moment. In order to prevent this turn, the right pedal must be moved forward. Increasing the thrust of the tail rotor creates a large moment, and the helicopter will retain its direction, but will begin to move to the left. In order to prevent this slip, the control lever must be moved to the right. This same dependence of one type of control on another is observed in horizontal flight, for example when accelerating. In this case, the cyclical pitch lever must be moved forward and left, the power must be changed using the "pitch-gas" lever and the position of the pedals must be changed as well.

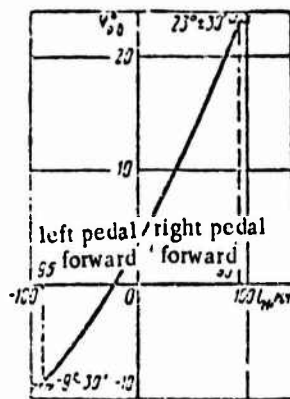

Figure 101. Interrelationship of Rotor Pitch and Pedal Travel

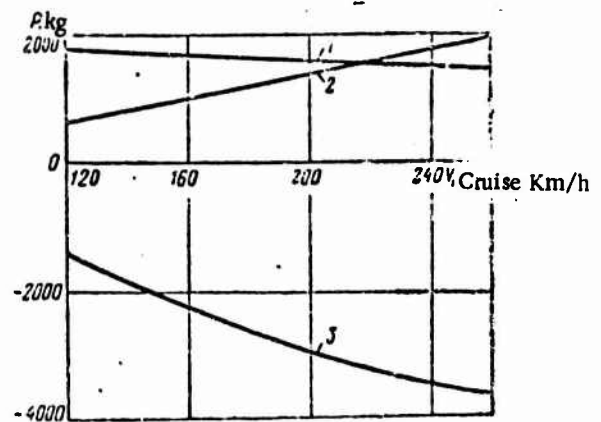

Figure 102. Change in Constant Forces on Hydraulic Amplifier Shaft as a Function of Flight Speed: 1, Control of lifting rotor general pitch; 2, Longitudinal control; 3, Transverse control.

When the pedals are moved, in addition to the change of the track moment of the tail rotor, bank and pitch moments arise as well. The bank moment appears as a result of the fact that the point of application of

the thrust of the tail rotor is higher than the center of gravity of the helicopter, the pitch moment--as a result of the change in reactive moment of the tail rotor. When the right pedal moves forward, the reactive moment of the tail rotor increases, the helicopter tries to pitch nose up; when the left pedal is moved forward, the helicopter tries to pitch nose down. Consequently, there is complete dependence of one type of control on the other in the Mi-6 helicopter, one defect of the helicopter. Usage of the autopilot in stable flying modes smooths out these control defects significantly.

In the Mi-6 helicopter, the "pitch-gas" lever and cyclical pitch lever are connected to the swash plate, while the pedals are connected to the tail rotor by the tail rotor pitch control system. The "pitch-gas" lever is connected to a slider and receives forces from the lifting rotor blades, attempting to lift the slider of the swash plate system. The general pitch control system includes a BU-32A hydraulic amplifier, the actuating shaft of which receives forces from the swash plate system slider. These forces increase with increasing speed and reach 2,000 kg at maximum speed. The maximum operating force created by the BU-32A amplifier is $\pm 12,000$ kg.

The cyclical pitch lever is connected to the outer ring of the swash plate system through the longitudinal and transverse control system. In the longitudinal direction, the swash plate strives to tip backward, leading to nose up movement. The longitudinal control system includes a BU-33A hydraulic amplifier, the shaft of which receives this force from the swash plate system. At low speeds, these forces amount to 1,800 kg, decreasing with increasing speed. The maximum force created by the hydraulic system on the actuating shaft of the hydraulic amplifier of the longitudinal control system is $\pm 6,000$ kg.

In the transverse direction, the blades of the operating lifting rotor produce a constant force on the swash plate, tending to tilt it to the right. With increasing speed, this force increases in absolute value, reaching the maximum value of 3,500-3,600 kg at the maximum flight speed. The transverse control system includes a BU-33A hydraulic amplifier, the actuating shaft of which receives this force. The hydraulic amplifier creates a maximum force of $\pm 6,000$ kg. The magnitude and nature of changes in these forces on the shaft of the hydraulic amplifier in the general pitch control system for the lifting rotor, as well as the amplifiers in the longitudinal and transverse control systems are shown as functions of horizontal flight speed on Figure 102.

The tail rotor pitch control system includes a BU-32A hydraulic amplifier, the maximum operating force of which is $\pm 6,000$ kg.

As we know, the hydraulic amplifiers relieve the control levers of forces completely; therefore, this control system of the lifting and tail rotors is called nonreversible.

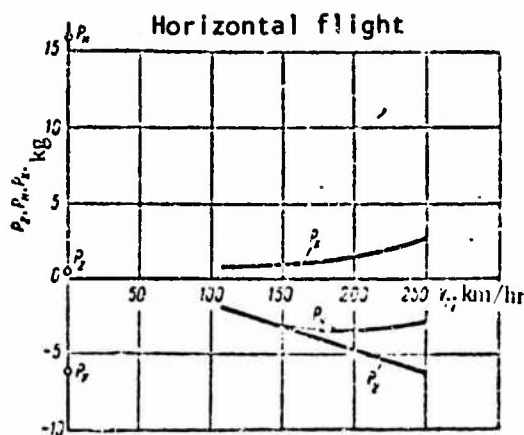

Figure 103. Change in Force on Cyclical Pitch Lever in Horizontal Flight in the Longitudinal Direction (P_x), Transverse Direction (P_z) and on the Foot Pedals (P_H) as Functions of Flying Speed with Neutral Position of Trimmers.

In case of a failure of the hydraulic system, the helicopter cannot be controlled.

In order that the pilot might feel the flight of the helicopter by forces on the control levers, and, i.e., in order that he might be able to judge the necessary direction for movement of the control levers, the longitudinal, transverse and track control systems include spring loading mechanisms. The MP-100 m electric trimmer mechanisms are provided to remove the force from the control levers in any stable flight mode.

With the trimmers in the neutral position, certain forces will be created on the control lever in the longitudinal and transverse directions and on the pedals at various flying modes and speeds, making it possible to feel the control by the force on the pilots feet and right arm. Figure 103 shows the values and changes of forces with changing flight speeds in the three control systems with neutral position of the trimmers in the horizontal flight mode with central longitudinal centering of the helicopter where $X_T = 0$, when the swash plate is moved in the transverse direction as shown in the shaded area of Figure 96, and also when the tail rotor pitch is changed within the limits shown in the shaded area of Figure 100. As we can see from the figure, the control lever carries a positive force P_x of 2 kg in the longitudinal direction at 100 km/hr, and when the speed is increased to 250 km/hr it is increased to 4 kg. Therefore curve P_x changes in the same manner as the balancing curve for longitudinal deflection of the swash plate with flight speed, i.e., the higher the speed, the further the swash plate must be deflected forward (see Figure 86).

On Figure 103, the vertical axis shows the force on the lever in the longitudinal direction in the hover mode with neutral position of the longitudinal trimmer. This force is negative, i.e., directed away from the pilot (pulling force) and is equal to -6 kg; consequently, the force on the lever in the longitudinal direction from the hover mode to a forward speed of 250 km/hr changes by a total of 10 kg.

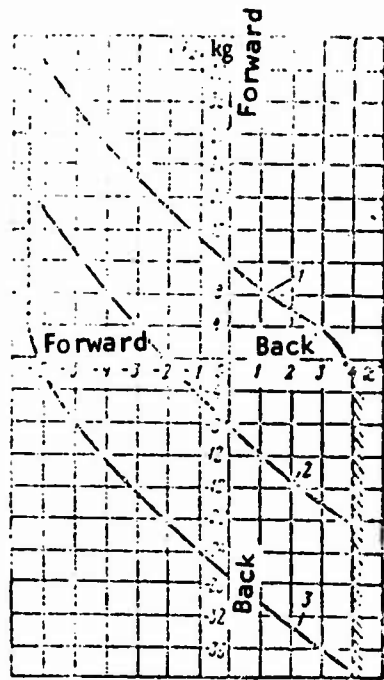

Figure 104. Force P_x on Cyclical Pitch Control Lever in the Longitudinal Direction as a Function of Deflection of Swash Plate and Position of Trimmer: 1, Extreme position of trimmer back; 2, Neutral position of trimmer; 3, Extreme position of trimmer forward.

NOT REPRODUCIBLE

In the transverse direction, the curve of forces P_z also follows the balancing curve for transverse deflection of the swash plate (see Figure 96). Here at 100-250 km/hr there will be a negative force (0-6 kg), i.e., a force pressing the lever to the right. As the speed changes from 100 km/hr to 0, the pressing force on the lever is directed to the left from the neutral position. Throughout the entire range of speeds from 0 to 250 km/hr, the force on the lever in the transverse direction will vary between zero and 11 kg.

The curve of forces on the pedals also follows the balancing curves of required tail rotor pitch as a function of horizontal flight speed (see Figure 100). At 100 km/hr, there will be no force on the pedals, with increasing speed to 200 km/hr a negative force appears, i.e., pressing on the left pedal (left pedal moves forward). With a further increase in speed, this force decreases in absolute value, i.e., the right pedal begins to feed forward. At less than 100 km/hr, force P_H is positive, i.e., there will be forward pressure on the right pedal, amount to 16 kg when hovering. Throughout the entire range of speeds from 0 to 250 km/hr, the force on the pedal changes, reaching up to 17 kg.

If the trimmers are used, the forces can be relieved from the loading mechanisms of all control levers in all flying modes. Figure 104 shows the dependence of force on the cyclical pitch lever in the longitudinal direction on angle of deflection of the swash plate, and therefore on movement of the lever with the trimmer in the neutral position and in its extreme positions "forward" and "back." As we can see from the figure, the force can be relieved from the cyclical pitch lever in the longitudinal

direction over a broad range of deflections of the swash plate from $3^{\circ}30'$ (back) to $-6^{\circ}30'$ (forward), i.e., over almost the entire range of deflection of the swash plate, which will be sufficient to relieve the forces over the entire range of speeds, in all flying modes with permissible limiting centerings of the helicopter. With the trimmer in the neutral position, in the extreme position the swash plate movement the load springs will create forces greater than those shown throughout the entire range of speeds from 0 to 250 km/hr (see Figure 103). This is explained by the fact that on the figure the forces are shown only with deflection of the swash plate and cyclical pitch lever in horizontal flight over the range of all speeds, with centering $X_T = 0$, and these deflections are not the limiting deflections, as shown on Figure 104. Figure 105a shows the same characteristics for the loading mechanism in the transverse control circuit, while Figure 105b shows the same curves for the pedal control circuit.

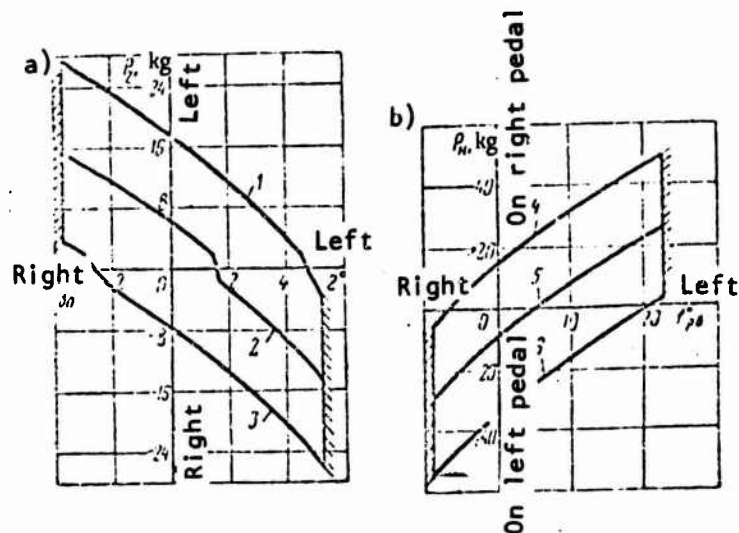

Figure 105. Characteristics of Loading Mechanisms of Mi-6 Helicopter: a, Force P_z on cyclical pitch lever in transverse direction as a function of deflection of swash plate and position of trimmer; b, Force P_H on pedals as a function of pitch of tail rotor and position of trimmer: 1, Extreme left position of trimmer; 2, Neutral position of trimmer; 3, Extreme right position of trimmer; 4, Extreme left position of trimmer; 5, Neutral of position; 6, Extreme right position of trimmer.

The "pitch-gas" lever has no similar device for loading, but rather is stopped in any fixed position using the hydraulic system. The gas corrector has a friction disk, the tightening of which is adjustable.

A delay in control of the lifting rotor is observed in the Mi-6 helicopter, which is not observed in the control of the tail rotor. This is explained by the different sizes of the rotors, which determines the time required to change the moments as the rotors are controlled.

Stability

The Mi-6 helicopter, like the Mi-4 helicopter, has static stability. The dynamics of the behavior of the helicopter in flight can be characterized as follows. After perturbations are stopped in the longitudinal direction, the deflection of the helicopter from the initial position is retarded, as speed is changed bank and slip appear.

If the helicopter is given a side perturbation, oscillations appear, particularly in the track direction. As a result of side perturbation, the helicopter moves smoothly in a spiral, the oscillations damping both in the transverse and in the track directions (angle of bank and turn).

It must be noted that any perturbed movement of the Mi-6 helicopter develops slowly, due to the large dimensions of the machine and the large moments of inertia; therefore, the pilot can notice these deflections, use his control levers and prevent further development of perturbed motion. Therefore, piloting the helicopter is not highly difficult. When flying under calm atmospheric conditions or even with moderate turbulence, after careful balancing of the Mi-6 helicopter in a stable mode it can fly for some time with the control levers released. At medium speeds of horizontal flight after the control levers are released, the helicopter will change its pitch angle by 10° and its bank angle by 5° in 10-15 sec.

The Mi-6 helicopter has generally satisfactory stability characteristics, and the usage of the autopilot in stable forward flying modes improves the stability characteristics even more, making piloting the helicopter considerably easier.

CHAPTER X. SPECIAL CASES IN FLIGHT

§30. Ground Resonance

The phenomenon of ground resonance arises when the two oscillating systems of the lifting rotor (blades moving around the vertical hinges) and helicopter interact. All helicopters with vertical hinges without dampers are subject to ground resonance. The dampers of the vertical hinges are primarily used to eliminate ground resonance. The designer always attempts to decrease the damping moment of the vertical hinges to zero. In helicopters with landing gear wheels, it is expedient to make it so that the frequency of natural oscillations of the helicopter is lower than the oscillating frequency of the lifting system, so that when the oscillations of the two systems rise they will occur with lower intensity and require less damping. A low frequency of natural oscillations of the helicopter is achieved by softening the landing gear shock absorbers, increasing the oscillating frequency of the support system--by increasing the damping moments of the vertical hinges.

In forward flight, particularly when the helicopter moves close to the ground, the blades oscillate about their vertical hinges, i.e., the angles between the blades change. The general center of gravity of the blades (rotor) moves from the axis of rotation of the rotor, an unbalanced centrifugal force appears on the hub, which rocks the lifting system at a certain frequency. When the helicopter is on the ground or moving over it, the oscillations of the lifting system increase, and the helicopter itself is in the suspended state so that its natural oscillating frequency increases; in this case the oscillating frequencies of the two systems may correspond (resonance). This leads to dangerous shaking of the helicopter, the unbalanced centrifugal force increases, as a result of which the oscillations of the entire helicopter increase rapidly.

The source of energy for the transverse oscillations of the helicopter is the engine. At a certain, low operating mode of the engine and low speed of the lifting rotor, the oscillations of the lifting system are damped by the running gear shock absorbers, the pneumatic tires on the wheels and the vertical hinge dampers. As the engine develops more power and the rotating speed of the lifting rotor increases, the forces causing oscillation increase, and the work of the damping forces decreases as a result of the increased thrust of the rotor and the decreased compression of the shock absorbers and tires. Beginning at a certain level, the influx of energy from the engines rocking the lifting system will be

greater than the energy dissipated in the shock absorbers and dampers, so that oscillations will arise and if measures are not taken immediately some parts of the helicopter may break. These oscillations will be developed primarily in the transverse plane, since the transverse moment of inertia of the Mi-6 helicopter is much less than the longitudinal moment of inertia.

In the Mi-6 helicopter, the phenomenon of ground resonance is clearly expressed and may arise over a wide range of lifting rotor speeds. The Mi-6 helicopter is subject to oscillations at the so-called first and second resonant frequencies.

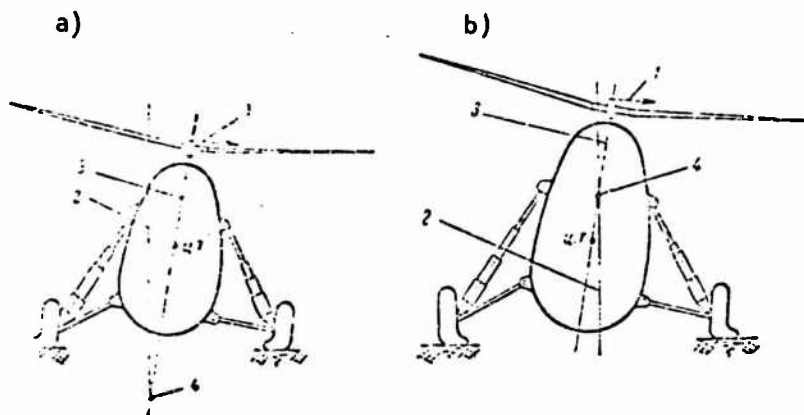

Figure 106. Oscillations of Mi-6 Helicopter Due to Ground Resonance: a, First resonant frequency; b, Second resonant frequency; 1, Unbalanced centrifugal force; 2, Plane of symmetry of unmoving helicopter; 3, Position of plane of symmetry during oscillations; 4, Center of oscillations.

During oscillations at the first resonant frequency, the helicopter rocks in the transverse plane about an axis passing below ground level (Figure 106a). As we can see from the figure, with this type of oscillation, the unbalanced centrifugal force not only tips the axis of symmetry of the helicopter, but at the same time shifts the helicopter and its center of gravity in the direction of the action of the force.

Oscillations of the helicopter at the first resonant frequency arise as the engine is started and the engine and transmission are tested on the ground in the lifting rotor operating range of 40-65% and during taxiing, when the thrust of the lifting rotor is comparatively low. With this type of oscillations, the tires do not separate from the ground.

It is characteristic for the transverse oscillations of the helicopter at the second frequency that these oscillations occur about an axis passing

above the center of gravity of the helicopter (Figure 106b). In this case, as unbalanced centrifugal forces act in the same direction as in oscillations at the first frequency, the helicopter tips in the direction of action of the force, but the center of gravity of the helicopter and its entire mass shifts in the opposite direction to the force on the rotor hub.

Oscillations of the helicopter at the second frequency appear at high thrust levels of the lifting rotor, as the thrust approaches the weight of the helicopter, when the shock absorbers are extended (oscillating energy not dissipated). This sort of resonance may appear after touchdown during an airplane type landing and in other cases when the helicopter is on the ground with the lifting rotor generating high thrust.

During this type of resonance, the wheels may separate from the ground.

In order to prevent oscillations of the helicopter of the first type, there is a spring damper connected to the high pressure chamber of the main landing gear shock absorbers (Figure 107). The spring damper is constructed so that it does not change the landing gear characteristics in case of identical force on both wheels, for example if the helicopter lands on both wheels without a bank, but greatly reduces the rigidity of the landing gear in case of different loads on the two wheels, which may occur during ground resonance transverse oscillations at the first resonant frequency or when the helicopter lands on one wheel. When the helicopter is parked or when it is moving along the ground when both wheels are identically loaded, the damper piston is in the central position. When the helicopter lands on one wheel or oscillates transversely at the first resonant frequency, the hydraulic fluid from the high pressure shock absorber on the side where the wheel is subjected to the higher pressure flows through the tube into the damper and presses its piston in the opposite direction to the stop in the end of the cylinder to the maximum value of 175 mm. The hydraulic fluid is expelled from the opposite end of the damper and flows through the valve and tubing into the opposite shock absorber. This softens the alternate blows of the wheel on the ground by expanding the volume of the cavity occupied by the hydraulic fluid.

In order to prevent ground resonance at the second frequency, the main shock absorbers of the landing gear have additional low pressure chambers which go into operation immediately after the wheels touch the ground or just before separation from the ground, when the thrust of the lifting rotor is high and the high pressure chambers do not operate. Then the oscillations of the helicopter are damped in the low pressure chambers, preventing the development of ground resonance. Furthermore, the hydraulic dampers of the vertical hinges of the lifting rotor blades are an effective means for preventing ground resonance. The advantage of hydraulic dampers over friction dampers is that their moment of friction increases with increasing oscillating amplitude.

The transverse oscillations depend on the flying weight of the helicopter, the characteristics of the landing gear shock absorbers, tires and hydraulic dampers in the vertical hinges. In the Mi-6 helicopter, the designer has selected a volume of hydraulic fluid and initial technical nitrogen pressure in the shock absorbers, initial air pressure in the pneumatic tires and hydraulic damper moment in the vertical hinges such that the oscillating frequency of the lifting system does not correspond to the natural oscillating frequency of the helicopter resting on the ground (being higher) so that with proper flying techniques of the helicopter, ground resonance will not occur in the Mi-6 helicopter. However, this does not mean that it never occurs. On the contrary, if the necessary level of hydraulic fluid and nitrogen pressure are not maintained in the landing gear shock absorbers, if the proper air pressure is not maintained in the tires, if errors are made in starting and testing the engine and transmission, if the limitations are not observed during taxiing, airplane type takeoffs and landings, ground resonance is possible on the Mi-6 helicopter.

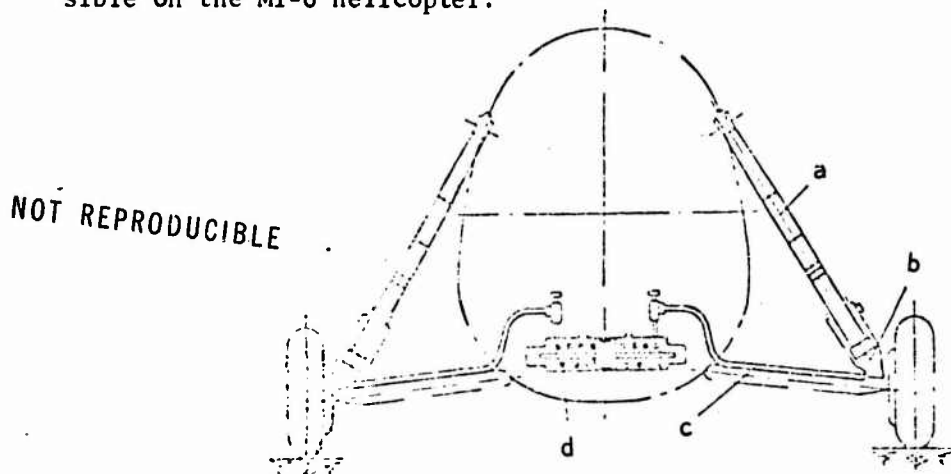

Figure 107. Diagram of Two-Chamber Landing Gear Shock Absorber: a, Low pressure shock absorber; b, High pressure shock absorber; c, Flexible hose; d, Spring damper.

The cause of ground resonance may be some insignificant factor: random irregularity of the surface of the earth, sharp gusts of wind, sharp or great deflection of the control lever from the position at which the setting angles of the blades do not change, high speed of movement along the ground, low surrounding air temperature, etc. A combination of these factors with poor condition of the damping system or improper maintenance of its characteristics during technical servicing may create favorable conditions for ground resonance. In practice, cases have been observed of ground resonance of the Mi-6 helicopter during start-up of the engines and acceleration of the lifting rotor after starting of the first engine, most frequently with minimum fuel reserve and wind from the right. These same factors can cause ground resonance when the engines are turned off a minute after being put in the idle.

In order to prevent the possibility of ground resonance on the Mi-6 helicopter, the following rules for technical and flying operation must be followed.

1. Observe precisely and perform correctly all adjustment operations involved in servicing of hydraulic dampers on lifting rotor hub.
2. Charge shock absorbers of landing gear with hydraulic fluid and technical nitrogen to the established norms: hydraulic fluid into high pressure shock absorbers, spring damper and lines--46 l, into low pressure shock absorbers--9.6 l, in front wheel shock absorber--6 l¹, initial pressure of technical nitrogen in high pressure shock absorbers of main wheels--48 kg/cm², in low pressure shock absorbers of main landing gear wheels--14 kg/cm², in front wheel shock absorber--27 kg/cm².
3. The pneumatic tires should be filled to the proper pressure: initial pressure in pneumatic tires of main wheels--7 kg/cm², in front wheel--6 kg/cm².
4. When possible, avoid starting engine and rotor with a side wind, particularly from the right, and in no case start the engine with a side wind of over 15 m/sec.
5. When taxiing, observe the following limits. Taxiing speed not over 20 km/hr. Taxi only with a wind of not over 25 m/sec, side wind 15 m/sec, tail wind 12 m/sec. Do not taxi over uneven, soft surfaces, over deep or loose snow. Retain rotating speed of lifting rotor at 78-82%.
6. During airplane type takeoff, assure minimum takeoff run length and time, separating from ground at not over 50-60 km/hr.
7. During airplane type landing, land at not over 50-60 km/hr. After touchdown always immediately drop general pitch lever to bottom stop, move gas corrector knob fully to left. Use wheel brakes to decrease landing run length and time.
8. During vertical takeoff, do not hold helicopter in suspended state long before separation of wheels from ground and do not hover near ground.
9. During vertical landing, do not hover for extended period of time near ground or leave helicopter in suspended state after touchdown.

If ground resonance occurs as the engines are being started, they must be stopped. If ground resonance occurs when the engines are being tested on the ground, the general pitch lever must be moved down

¹When filling and refilling shock absorber uprights, the quantity of AMG-10 hydraulic fluid must be determined by its level up to the filler valve apertures with standard compression of the uprights.

immediately and the engines must be turned off, periodically braking the lifting rotor until the oscillations of the helicopter are fully stopped by smoothly, briefly engaging the rotor brake. As the rotating speed of the lifting rotor drops, the oscillations of the helicopter will gradually decrease.

When ground resonance appears in all other cases and in all stages of its development, the source of the energy of these oscillations--the operating engines--must be damped, the shock absorbers and tires must be compressed, the flapping movement of the blades around the horizontal hinges must be stopped, and their lead-lag oscillations about the vertical hinges must be decreased. This can be done by rapidly decreasing the general pitch to the minimum and simultaneously rotating the gas corrector to the left. The cyclical pitch lever must be put in the neutral position and, if resonance is started during the takeoff run of an airplane type takeoff, landing run of an airplane type landing or taxiing, the wheel brakes must be used to drop speed rapidly. If the oscillations do not stop, the engines must be turned off. If the oscillations still do not stop, the lifting rotor must be braked.

931. Possible Tipping of the Helicopter on the Ground

When started from a stop, accelerated or taxied on the ground, and also during a vertical takeoff or landing in case of improper actions by the pilot, conditions may be created when the Mi-6 helicopter will be tipped over onto one side relative to the axis passing through the front wheel and one of the main wheels (Figure 108b). This tipping is facilitated by the fact that the helicopter has a three wheel landing gear, a high center of gravity and great mass.

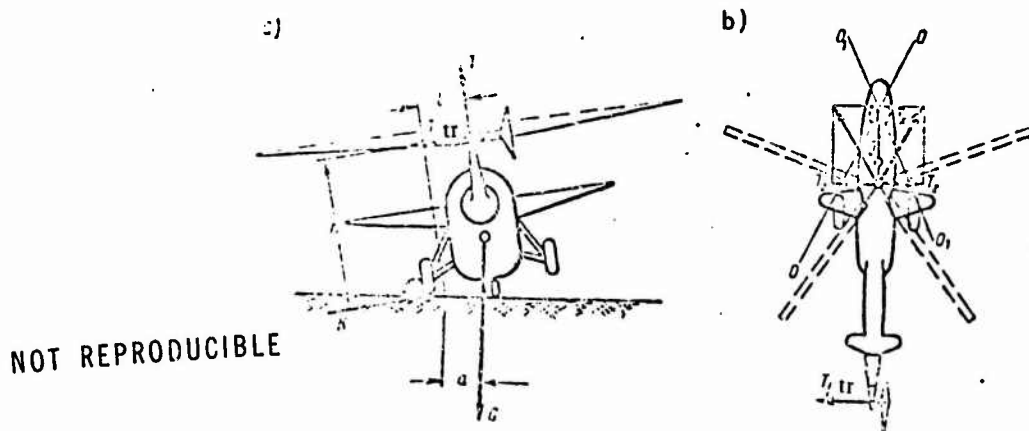

Figure 108. Diagram of Forces in Moments Acting on the Mi-6 Helicopter on the Ground: a, Left bank; b, Top view.

The following forces tend to tip the helicopter: the thrust of the tail rotor, the side thrust of the lifting rotor T_z , the longitudinal thrust of the lifting rotor T_x . All of these forces act on an arm equal to the distance from their point of application to the OO or the O_1O_1 axis, and create the corresponding moments. If the helicopter tips, the force of the thrust of the lifting rotor over arm l (Figure 108a) will also tend to continue tipping the helicopter. The higher the thrust, the greater will be the moment increasing the bank and the less stable will be the helicopter on the ground. The force holding the helicopter in the state of equilibrium will be the weight of the helicopter.

In order to prevent sliding along the ground, it is necessary that side force T_z be directed to the right, in order to balance the thrust of the tail rotor. With the helicopter on the ground, the pilot has nothing to guide him in determining the equality of these two forces, so an error can be made easily. If the side force becomes greater than the thrust of the tail rotor, a right slip will occur, whereas if it is less than the thrust of the tail rotor, is absent or acts in the direction of the thrust of the tail rotor, the helicopter will slide to the left. If the surface is uneven or soft and a mound of dirt builds up beside the wheel as it slips, preventing further sideways movement of the helicopter, dangerous conditions are created for tipping of the helicopter to the right or the left.

Let us assume that the side force T_z is absent or is essentially less than the tail rotor force. The following moments will act on the helicopter relative to the support points of the left and front wheels: the moment of the thrust of the lifting rotor T_l , are directed to the left, in the same direction as the moment of thrust of the tail rotor $T_{tr}h$. The moment of the weight Ga will be directed in the opposite direction. If the thrust of the lifting rotor is less than the weight of the helicopter, the moment of the force of the weight will be greater than the sum of moments of lifting and tail rotor thrust: $Ga > T_l l + T_{tr} h$, and the greater this inequality, the more stably the helicopter will rest on the ground.

If for some reason the helicopter tips to the left relative to the OO axis (see Figure 108b) for example due to upward force applied to the right wheel as it taxis over uneven ground, the forces created by the thrust of the lifting and tail rotors and the force applied by the rise in the ground to the right wheel will create moments increasing the tilt, while the weight will tend to decrease the tilt. The tilt which is created changes the relationship of these moments so that with increasing tilt the weight moment decreases due to the decrease in arm l , since the center of gravity approaches line OO about which the helicopter has begun to rotate. Therefore, the stability of the helicopter is decreased.

When it reaches a certain critical tilt angle, the tilting moments of the rotor thrust will equal the moment of the weight which tends to restore equilibrium,

$$G_a = T_L + T_{tr} h$$

and the helicopter will reach equilibrium at the support points of the left and front wheels, and if the tilting moments exceed the weight moment slightly ($G_a < T_L + T_{tr} h$) the helicopter will continue to tip, and unless emergency measures are taken, it will tip over.

The same danger of a tip to the right occurs if the helicopter begins to tip in this direction when there is a side force, particularly if the side force is greater than the thrust of the tail rotor. However, the danger of tipping to the right is less due to the constant thrust of the tail rotor.

Furthermore, the following factors tend to increase the tendency of the helicopter to tip: movement of the center of gravity of the helicopter forward (forward centering) causing a decrease in the righting moment resulting from the weight; side winds, excessive movement of the cyclical pitch lever forward, causing the thrust to tilt and increasing the tipping moments.

In order to avoid tipping of the helicopter, all limitations concerning movement on the ground must be strictly observed. If the helicopter has started to tip for some reason, the general pitch lever must be immediately and rapidly moved fully downward.

This causes the thrust of both rotors to decrease, and the helicopter regains its lost equilibrium. It should be firmly recalled that movement of the foot pedals in the direction opposite to the tilt or slip does not help to relieve the tipping or stop the sliding, but rather simply makes things worse.

If the pilot must use the pedals when a tip occurs, he should deflect the pedals in the direction of the tip.

In some cases, the pilot can avoid tipping by causing the helicopter to separate from the ground.

§32. Overweighting of Lifting Rotor

There are three possible cases of overweighting of the lifting rotor: the "pitch-gas" lever, with the gas corrector in the right position, is rapidly moved upward; the "pitch-gas" lever is moved upward by more than 9° in vertical flying modes, even if done at normal rates with the gas corrector moved fully to the right; the "pitch-gas" lever is moved back without using the gas corrector.

Let us discuss each case individually in more detail.

1. This case of overweighting of the rotor is characteristic for vertical takeoffs, vertical climbs and maneuvers in the hovering mode. The general pitch of the lifting rotor and the position of the gas corrector may be normal, but the pilot moves the general pitch lever upward to increase engine power and thrust of the lifting rotor too rapidly. Due to the delay in pickup of the engines, their power cannot increase to correspond to the increased lifting rotor pitch, so that the rotor becomes too heavy. Another case is also possible: as the general pitch of the rotor is increased, due to the inertia of rotation its thrust may increase briefly, so that the helicopter separates from the ground if a takeoff is being performed or climbs if a vertical climb from the hovering mode is desired, but then the rotating speed and thrust drops sharply and the helicopter begins to descend. It would be an even greater error on the part of the pilot to attempt to prevent this descent by increasing the general pitch, since this might cause damage to the helicopter.

If the blade becomes too heavy, the general pitch must be decreased, while retaining the horizontal position of the helicopter with the cyclical pitch lever; the helicopter will descend, the rotating speed will increase and the descent may end by itself. Or, the descent may be ended by the influence of the air cushion, the helicopter hovering on the air cushion or touching down smoothly. If the helicopter moves toward the ground too rapidly, the blow against the ground must be softened by rapidly increasing rotor weight, performing a "high pitch" landing. This case of overweighting of the rotor may also cause surging in the engines.

This case of overweighting of the lifting rotor may occur not only in takeoff and vertical flying modes, but in any flying mode with forward speed, except the results of the overweighting will be less dangerous. The decrease in the rotating speed of the rotor will cause a decrease in thrust of the lifting rotor, the helicopter will descend, and if the flight speed is high, slow separation may occur.

2. This case of overweighting of the rotor is characteristic for a vertical takeoff or vertical flying modes with high flying weight of the helicopter, with the engine in takeoff mode or near it. In this case, with the gas corrector fully to the right, the general pitch of the lifting rotor is 9° . If the general pitch is increased, the rotor will become heavy, while the power of the engines will remain unchanged, since the fuel valves are fully opened, the indications of the UPRT-2 are maximum (see Figure 50, point e). The rotating speed of the rotor will drop rapidly, and consequently so will the rotor thrust, and the helicopter will begin to descend. Following the diagram of the operation of the "pitch-gas" system shown on Figure 50, movement will occur from point e to point f.

In this case of overweighting of the rotor, the actions of the pilot should be the same as in the first case.

3. This case of overweighting of the lifting rotor is also characteristic for vertical flight modes, but is less dangerous. It may occur in any mode if the pilot uses the "pitch-gas" lever alone, without noticing the rotating speed of the lifting rotor and maintaining it using the gas corrector within the permissible range for the flying mode used. During take-offs or vertical flying, usage of the general pitch lever alone without preliminary adjustment using the gas corrector may lead not only to overweighting of the rotor but also to surging of the engines.

§33. Vortex Ring

The vortex ring mode during a vertical descent has the same characteristics and regularities for the Mi-6 helicopter as for any other single rotor helicopter. In order to avoid the vortex ring mode, vertical descent in the Mi-6 helicopter should be conducted at 1-2 m/sec. The pilot must be sure that the speed does not exceed 2-3 m/sec even briefly.

With a descent rate of up to 2 m/sec, the vortex ring is formed beneath the rotor and represents no danger; with descent speeds of over 2 m/sec, increased vibrations of the helicopter arise, controllability is decreased, the thrust of the lifting rotor decreases and the vertical descent rate increases sharply. Increasing motor power does not always produce the desired result. Therefore, if a descent rate of 2 m/sec is reached, it is recommended that the operating mode of the engines be increased to avoid further increases in vertical descent rate.

In the vortex ring mode, i.e., at descent rates of over 2-3 m/sec, the general pitch of the lifting rotor must be increased. If this does not produce positive results, the general pitch should be increased once more and the helicopter should be put in the forward flight mode by deflecting the cyclical pitch lever forward.

§34. Flutter Vibrations of Blades

Flutter vibrations of the lifting rotor blades are just as characteristic for a helicopter as for the wings of an aircraft. As we know from flutter theory, it begins at the critical rate of flow past a wing or lifting rotor blade. Since the blade receives flow due to its movement in a circle--circular velocity and due to the flying movement--forward velocity, the helicopter is evaluated for flutter characteristics according to the critical rotating speed of the lifting rotor and the critical forward flying speed of the helicopter. The problem of the designer is to achieve critical flutter rotating speeds and critical flutter forward speeds such that they are higher than the maximum permissible speeds used in operations.

This problem has been successfully solved for the Mi-6 helicopter. The principal factor influencing the critical flutter rpm and flight speed is the transverse centering of the blades of the lifting rotor: the greater the forward centering, the higher the critical rpm and critical flutter flight speed and vice versa.

Furthermore, the critical flutter rpm and flight speed are influenced by other factors, both constant (rigidity of design, characteristics of flat regulator) and variable (friction in axial hinges, point of application of center of pressure along cord of blade, etc.) Since the variable factors may change during operation for various reasons, the helicopter should always have a reserve of flutter rpm and forward speed. The flutter rpm reserve is the difference between the rotating speed at which flutter appears and the rotating speed which is the maximum permissible speed in operation. The reserve of forward speed for flutter is the difference between the speed at which flutter appears and the maximum permissible forward speed used in operation.

Reserve of rpm and speed before flutter can be achieved by changing the transverse centering of the blades. Therefore, reserves of rpm and speed before flutter are replaced by an equivalent reserve of transverse centering before flutter, which is changed and tested during the manufacture of the blades and as they are repaired by the installation of ant Flutter weight. The Mi-6 helicopter blades have the following flutter centering reserves: for the trapezoidal blades--2.25%, for the rectangular blades--1.7%.

The flutter reserve of centering is the difference between the centering at which flutter appears and the actual centering of the blade. These centering reserves as used on the Mi-6 helicopter guarantee the absence of flutter in all flying modes, if the rotating speed of the lifting rotor does not exceed the maximum permissible speed (87%) and the flight speed for the helicopter with trapezoidal blades does not exceed 265 km/hr, for the helicopter with rectangular blades--300 km/hr, indicated.

Flutter tests both on the ground and in flight have been performed. For the trapezoidal and rectangular blades, displacement of centering by 1.6% by installing additional weights on the trimmer plates was performed. With these blades, when tested on the ground, flutter did not appear with the blades rotating at 90%. In flight, flutter did not appear in the helicopter with trapezoidal blades with the lifting rotor at 87% and at 320 km/hr, or in the helicopter with rectangular blades with the lifting rotor at 78% and at an indicated speed of 350 km/hr. Consequently, the critical rpm and speed for flutter of the Mi-6 helicopter have not been established, but are known to be higher than the figures just mentioned.

In operation, the flutter reserves of blade centering just mentioned may change as a result of repair of the blade or penetration of moisture into the blades. The critical rpm and speed for flutter may also change

as a result of change in friction in the hinge bearings or displacement of the centers of pressure on the blades, so that flutter of the blades may occur in flight as an exception. The pilot should know the indications of flutter and methods for stopping this type of vibration, and should clearly recall all limitations related to flutter.

For the Mi-6 helicopter, the indications of flutter are: washout of blade funnel (movement of blades outside common cone of rotation), change in the nature of vibration of the entire helicopter and control levers ("shuddering" of helicopter, "jerking" of control lever).

When the first signs of flutter appear, the rotating speed of the lifting rotor and flying speed must be reduced to the minimum permissible. After vibration stops, the flight should not be continued: a suitable landing area should be located and a forced landing made.

§35. Exceeding Maximum Permissible Flight Speed

Flow separation from the blade tips may occur if the maximum permissible flight speed is exceeded, or if the rotating speed of the rotor is allowed to drop below the minimum permissible or the general pitch is increased above the maximum permissible at high flight speeds, when flying in bumpy air, in case of an overload, etc. However, the most frequent error in piloting the Mi-6 helicopter is exceeding the maximum permissible flight speed for the helicopter with a given type of lifting rotor blades at a given altitude, which is accompanied by the following sign.

1. Increased vibration of the helicopter appears, increasing with increasing flight speed.
2. Controllability is worsened (the helicopter reacts poorly to movements of all control levers).
3. The helicopter turns nose up and banks right, rocks in the longitudinal and particularly in the transverse direction.

In order to prevent these phenomena, the pilot should: smoothly decrease the general pitch, set the recommended rotating speed for the given altitude depending on blade type of the lifting rotor; decrease his speed as much as necessary. Then the required engine operating mode should be set and flight continued.

§36. Failure of One Engine in Flight

The pilot will detect an engine failure both due to the unbalancing of the helicopter and from his instruments. The helicopter will turn to the right due to the decrease in reactive moment of the lifting rotor,

simultaneously banking to the right due to the decrease in thrust of the tail rotors; the nose will drop. The rpm indicator will show a drop in the rotating speed of the turbine compressor and lifting rotor, a decrease or increase in gas temperature beyond the turbine in the engine which has failed, a decrease in oil pressure at the intake to the engine or lifting rotor turbine. As the fuel pressure drops, the signal light will come on on the flight engineers control panel.

An engine failure may be sudden and complete, or partial.

With a sudden, complete failure of an engine, the general pitch of the lifting rotor should be immediately decreased by 4-6°, and the gas corrector simultaneously moved to the right. This is necessary in order to avoid a sharp change in the rotating speed of the lifting rotor. If the pilot acts properly, the rotating speed of the lifting rotor will decrease by 5%. In order to counter the turn and bank to the right and the dropping nose, the cyclical pitch lever must be moved to the left and back and the left pedal moved forward. After this, both separate control levers for the engines must be smoothly but rapidly moved to the top position. Since with a sudden failure the pilot cannot immediately determine which engine has failed, he must shift both engines into the maximum operating mode using the separate control levers. He must then increase the general pitch lever, not allowing the rotating speed of the lifting rotor to rise above the maximum permissible.

The pilot then takes up a speed of 130-150 km/hr, determines which engine has failed and drops the separate control lever of this engine into the slot.

With a partial engine failure, the pilots actions are the same as with a sudden failure, but only the operating engine is put in the take-off mode.

In order to avoid a fire in the engine which has failed, the fuel supply to this engine must be cut off, closing the mechanical stop valve. The flight engineer closes the fire valve of the engine which has failed.

Since when the separate control lever is moved fully upward the gas corrector knob moves to the left by itself and its travel becomes insufficient to maintain the required rotating speed, the separate control lever must be brought down somewhat until the gas corrector knob can be rotated over a wider range. The crew then checks to see that the engine is operating in the takeoff mode with the gas corrector lever fully to the right. The rotation of the gas corrector to the left with the separate control lever in its uppermost position results from the kinematic control of the "pitch-gas" system and separate control of the engines. Horizontal flight is continued at 130-150 km/hr.

The characteristics of horizontal flight and descent of the Mi-6 helicopter with one engine operating were given earlier. We need only

add that when the helicopter descends with one engine operating at the nominal mode in flights over mountain terrain or water spaces, any operating mode of the engine required can be used, disregarding the limitations as to time. If flight to the nearest heliport is impossible, a suitable location must be selected and a forced landing made with one engine operating.

Landing the Mi-6 helicopter with one engine operating. The method of landing the helicopter with one engine turned off for training purposes or in case of failure of one engine is the same, but in both cases only airplane type landings can be performed due to the insufficient power of one engine for a vertical landing. Descent to the area selected is performed at 130-140 km/hr at a vertical speed of 2-3 m/sec (but not over 4 m/sec). The landing course is corrected and rotating speed of the lifting rotor maintained using movements of the "pitch-gas" lever and gas corrector knob. However, when one engine operates these movements must be smoother and more coordinated, since if the "pitch-gas" lever is moved upward, the rotating speed of the lifting rotor drops more rapidly than when both engines are operating. The descent before the landing should be made at 130-140 km/hr with a vertical speed of 1.5-2 m/sec (Figure 109). The vertical and forward speed should be decreased beginning at 25-30 m altitude by slight movement of the cyclical pitch lever back and smooth movement of the general pitch lever and corrector knob, maintaining the lifting rotor speed within the operating range. At 5-6 m altitude, the helicopter is put in the landing position by moving the cyclical pitch lever forward and the vertical speed is decreased further by moving the general pitch lever upward so that at the moment of touchdown the vertical speed is not over 0.5 m/sec. If the levers are moved in this manner, the helicopter should land on its main wheels at a landing speed of 60-70 km/hr. After touchdown, the "pitch-gas" lever must be moved downward to its stop, the gas corrector knob moved to the left and the separate control knob for the operating engine dropped into the slot. During the second half of the landing run, at not over 50 km/hr, the brakes can be used to decrease the run length. With normal flying weight of the helicopter under standard atmospheric conditions above sea level, the landing distance is 800 m, the landing run distance--240 m.

When it is necessary to land on a limited area, the method of the landing with one engine is the same, except that in order to decrease the landing run length the landing speed must be less than 60-70 km/hr, achieved by more energetic movement of the cyclical pitch lever backward. This type of landing may cause damage to the helicopter.

The landing with one engine operating should be performed against the wind, but the limitations as to wind speed and direction allowed are the same as for an airplane type landing with two engines operating.

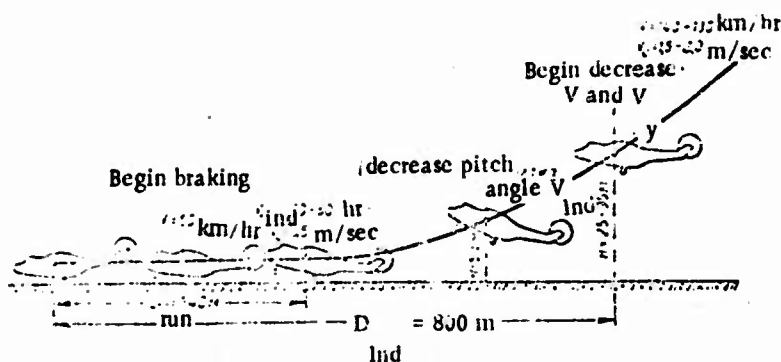

Figure 109. Profile and Elements of Landing of Mi-6 Helicopter with One Engine Operating.

§37. Failure of Both Engines in Flight

Failure of both engines will be determined by the sudden, sharp unbalancing of the helicopter: it turns and banks to the left, drops its nose, descends and a sharp decrease in the rotating speed of the lifting rotor and turbine-compressors of both engines will be noted from the instruments, as well as a decrease in gas temperature beyond the turbine. The transient mode from the moment of engine failure to stable gliding lasts 12-17 sec, during which time the helicopter will lose 150-200 m altitude. In order to avoid a great decrease in the rotating speed of the lifting rotor and moderate the descent, if both engines fail the pilot must immediately drop the general pitch lever to the lower stop, regardless of altitude and flying weight of the helicopter, then establish the permissible rotating speed as a function of altitude and type of rotor on the helicopter (see Tables 6 and 7). At altitudes up to 1,000 m, the general pitch should be 1° ("pitch-gas" lever down), at 2,000 m it should be about 4° , at 3,000 m-- 5° . In order to avoid unbalancing the helicopter, at the same time the general pitch is dropped, the right turn should be countered by moving the left pedal forward, the right bank--by moving the lever to the left and the tendency to dive--by moving the control lever back.

The loads which arise on the control lever and pedals can be removed using the trimmers.

In order to avoid a fire, the fuel supply to the engines should be shut off: close the stop valves and fire valves. If the wing is controllable, the co-pilot should move it to its lowest setting angle.

A speed of 130-140 km/hr is set, for which the vertical descent rate will be minimum. At 120-100 m altitude, the speed should be moderated, i.e., at this altitude the landing is actually begun. Landing of the Mi-6 helicopter with both engines out does not differ from the training landings with both engines turned off described in Chapter VIII.

In case there is no landing area available corresponding to the requirements of heliports for heavy helicopters, the prelanding speed can be less

than 130-140 km/hr, or even less than 100 km/hr, but in this case damage to the helicopter may result.

538. Surging of Engines

The phenomenon of surging is characteristic for gas turbine engine compressors. The compressor is designed to compress and supply a certain calculated quantity of air per second, for which the efficiency of the compressor is maximum.

When each stage of an axial compressor operates at its design mode, the direction of the resulting velocity W of the intake air flow (Figure 110a) corresponds to the direction of the intake edges of the blades, the angle of attack of the air flow on the blades thus being zero. The flow moves slowly around the blades, and they create minimum drag. In this mode, the losses of energy to vortex formation are minimum.

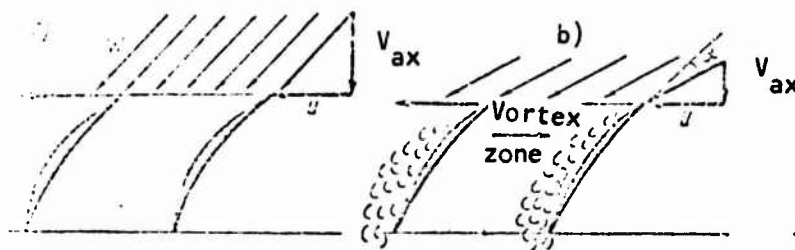

Figure 110. Flow Around Blades of Axial Compressor Stage: a, Design mode; b, Surge mode.

If a smaller or larger quantity of air flows through the compressor than the design quantity, the compressor operates in a non-design mode. If a quantity of air less than the design quantity flows through the compressor, the axial speed of movement of the air V_{ax} is decreased, and at the same rotating speed of the compressor the angle of attack α increases (Figure 110b). In this case, the air flow separates from the backs of the turbine blades and creates a vortex zone--flow separation. The vortex zone disrupts the smooth flow of air between blades. However, the main flow of air quickly blows away the vortex zone, after which it is formed again. This alternation of vortex zones behind the blades causes pulsation of pressure and air flow speed. The operation of this compressor stage becomes unstable; this phenomenon is called surging.

The pulsating air flow moves from the first stages to subsequent stages and causes unstable, uneven operation in these stages as well, until the entire compressor is surging. The compressor cannot be allowed to operate in this mode, since the efficiency of the compressor is decreased, blade vibration is increased, possibly causing blade breakage.

The compressor is designed so that within the limits of the operating modes, surging will not occur. This is achieved by proper selection of blade shapes and setting angles.

In order to eliminate surging, air bypass after stages III and IV of the compressor is provided in the D-25V engine. This is achieved automatically through apertures covered by bypass strips. The engine operates with the strips open in the compressor rotating speed range from $78 \pm 1\%$ to $82.5 \pm 1\%$ (most unstable, uneven operation of first stages of compressor). This increases the air flow rate through the first stages of the compressor, increases the axial velocity of the air V_{ax} , causing the triangle of velocities at the input to the compressor to approach the design mode, allowing flow around the blades without flow separation, without formation of vortexes and preventing surging.

In spite of the bypass strips, in engines of the first production series and up to No. S3342001 of the second series, surging and high vibration stresses did appear on the blades of the first stage in the compressor speed range of 6,000 to 7,500 rpm. This prevented choking of the engines in order to shift the lifting rotor to the autorotation mode, and required careful piloting in other flying modes, requiring that many flying limitations be used. In order to eliminate these defects, engines of the second series, beginning at No. S3342001 were produced with perforation¹ of the body over the first stage of the compressor rotor.

When the body is perforated over the first stage of the compressor rotor, surging can occur only in case of a failure of the bypass strip control system or a sharp increase in the operating mode of the engine with the air bypass strips closed. Many flying limitations placed on the Mi-6 helicopter to prevent surging have thus been removed. Both on the ground and in flight, the appearance of surging is accompanied by the following indications: a sharp increase in gas temperature beyond the turbine, characteristic engine noises and a decrease in compressor rpm.

In order to prevent surging on the ground, the gas corrector must be moved smoothly to the right over a time of at least 2-3 sec, and after the lifting rotor speed is at least 78%, then the "pitch-gas" lever can be moved upward. In case of surging on the ground, the engine must be turned off.

In order to prevent surging in flight as the power is increased, the rotating speed of the lifting rotor must be carefully followed, allowed to increase slowly, and all flying limitations based on surging

¹ Perforation means drilling of apertures in a certain order using special machines (perforators).

must be observed. If surging appears in flight, the engine which is surging must be turned off and the separate control lever of the functioning engine placed in the upper position, then the pilot should continue the sequence used when one engine fails.

If a defect arises in the bypass strip system in flight, flight can be continued, except that the rotating speed of the compressor should not be allowed to drop below 83% for engines of the first series or 78% for engines of the second series. The "pitch-gas" lever and the corrector knob should be moved to the right. After the landing, the engine in which the bypass strip control system is not functioning properly should be turned off.

§39. Failures on Helicopter Control Systems in Flight

Failure of Directional Controls

A failure of the directional controls is possible in two cases: in case of a failure of the system which changes the pitch of the tail rotor and in case of a breakage of the tail rotor or its transmission.

In case of a failure of the tail rotor pitch changing system, the tail rotor will create a certain thrust and the helicopter will attempt to turn, and the tendency to turn will not be correctable by the usage of the pedals. In this case, the helicopter must be balanced with the corresponding slip, the flight continued to the nearest heliport and an airplane type landing performed.

In case of a breakage of the tail rotor or its transmission, the tail rotor will provide no thrust, the helicopter will begin to turn to the left due to the reactive moment of the lifting rotor and bank to the right due to the unbalanced side force. Furthermore, the nose of the helicopter will drop, since there will be no more reactive moment from the tail rotor. The helicopter may also tend to climb due to the power no longer consumed by the tail rotor.

If the tail rotor fails at low altitude during vertical flying, the pilot should prevent the helicopter from climbing, counter the right bank and tendency to lower the nose, then land the helicopter by decreasing the general pitch of the lifting rotor. At the moment of touchdown, the general pitch of the lifting rotor must be immediately reduced to the minimum and the gas corrector moved to the left. This will eliminate the reactive moment of the lifting rotor which will rotate the helicopter on the ground to the left, creating a moment tending to tip the helicopter over to the right. If the tail rotor fails in forward flight at an altitude of up to 500 m, the helicopter should be shifted to the autorotation mode by moving the general pitch lever downward to the stop, rotating the gas corrector to the left. The helicopter will turn right at a low angular velocity. This turn must be eliminated by setting up left slip.

The gliding speed should be adjusted to 140 km/hr. The stop valves should be turned off and the fire valves of both engines closed. The landing must be performed in the autorotation mode. One specific feature of this type of landing is that the approach is achieved with a left bank in order to prevent the right turn. As the helicopter approaches the ground, the bank must be reduced so that the helicopter touches down without a bank. During the run, the helicopter will tend to turn right due to the rotation of the lifting rotor in this direction. This turn cannot be prevented by the pilot; it will decrease as the rotating speed of the lifting rotor decreases and the wheels pick up friction on the ground.

If total failure of the tail rotor occurs at an altitude of over 500 m, the direction of flight can be maintained after the lifting rotor is put in the autorotation mode not only by slipping, but by changing power. As the helicopter approaches the ground, the actions of the pilot should be the same as for a failure of the tail rotor at an altitude of less than 500 m.

Failure of Trimmer Control System

In case of seizure of the trimmer control button on the control lever of the left pilot, the trimmers will take up one of their extreme positions, and a significant force will develop on the cyclical pitch lever (see Figure 104 and 105). Control of the trimmers must be shifted to the right pilot, giving him control of the helicopter and continuing the flight. If seizing of the control buttons occurs on both control levers and the forces required are high, an area must be selected for a forced landing.

The trimmers may fail to operate as a result of the failure in the MP-100 mechanism or breakage of a wire. In this case, the trimmer switch must be turned off. If the forces on the control lever are too high, an area must be selected for a forced landing, if they are not too high-- a landing should be performed at the nearest airport or heliport.

UNCLASSIFIED

Security Classification

DOCUMENT CONTROL DATA - R & D

(Security classification of title, body of abstract and indexing annotation must be entered when the overall report is classified)

1. ORIGINATING ACTIVITY (Separate entry) Foreign Science and Technology Center US Army Materiel Command Department of the Army	2a. REPORT SECURITY CLASSIFICATION UNCLASSIFIED
	2b. GROUP

3. REPORT TITLE
PRACTICAL AERODYNAMICS OF THE MI-6 HELICOPTER

4. DESCRIPTIVE NOTES (Type of report and Inclusive dates)
Translation

5. AUTHOR(S) (Last name, middle initial, first name)
M. S. Yatsunovich

6. REPORT DATE 2 November 1970	7a. TOTAL NO. OF PAGES 207	7b. NO. OF REFS N/A
-----------------------------------	-------------------------------	------------------------

8a. CONTRACT OR GRANT NO. 8. PROJECT NO. a. T702301 2301 4. Requester: Mr. McInturff	9a. ORIGINATOR'S REPORT NUMBER(S) FSTC-HT-23-1172-70
	9b. OTHER REPORT NO(S) (Any other numbers that may be assigned this report) ACSI Control Number (None)

10. DISTRIBUTION STATEMENT
This document has been approved for public release and sale; its distribution is unlimited.

11. SUPPLEMENTARY NOTES	12. SPONSORING MILITARY ACTIVITY US Army Foreign Science and Technology Center
-------------------------	---

13. ABSTRACT

This book presents a brief description of the helicopter, the aerodynamics of its lifting system and fuselage, characteristics of the D-25V gas turbine engine and the "pitch-gas" system.

The basic flying modes of the helicopter, methods for performing them and flying limitations for the Mi-6 helicopter with trapezoidal and rectangular lifting rotor blades, as well as problems of balancing, control centering and stability of the helicopter and special cases in flight are analyzed. The diagrams of forces in flying modes with forward speed are presented for simplicity without considering banking or slipping with which the helicopter should be balanced. These problems are discussed in the analysis of balancing of the helicopter.

The book is designed as a textbook for civil aviation flying schools. It can be used by the flying personnel of the helicopter aviation service. It has 110 figures, and 15 tables.

10. KEY WORDS	LINK A		LINK B		LINK C	
	ROLE	WT	ROLE	WT	ROLE	WT
Mi-6 helicopter D-25 gas turbine engine lifting system fuselage aerodynamics rotor blades balancing						