

AD 717495

United States Naval Postgraduate School

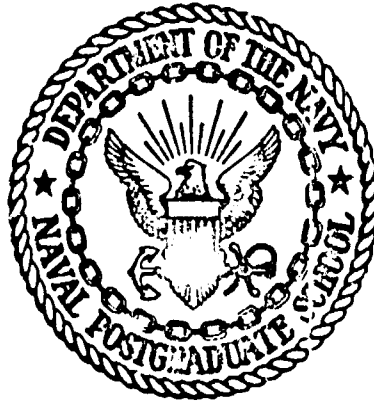

THE SIS

A STUDY OF PASSIVITY OF IRON
IN NON-AQUEOUS SOLUTION

by

Stephen Marks Burkhalter

June 1970

*This document has been approved for public re-
lease and sale; its distribution is unlimited.*

Reproduced by
**NATIONAL TECHNICAL
INFORMATION SERVICE**
Springfield, Va. 22151

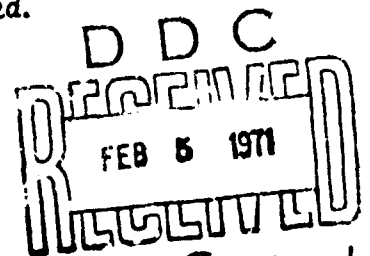

66

A Study of Passivity of Iron in Non-Aqueous Solution

by

Stephen Marks Burkhalter
Lieutenant (junior grade), United States Navy
B.S., United States Naval Academy, 1969

Submitted in partial fulfillment of the
requirements for the degree of

MASTER OF SCIENCE IN CHEMISTRY

from the

NAVAL POSTGRADUATE SCHOOL
June 1970

Author

Stephen M. Burkhalter

Approved by:

Robert W. Hellenick

Thesis Advisor

John H. Duffin

Chairman, Department of Chemistry

R. F. Richardson

Academic Dean

ABSTRACT

Passivity in aqueous solutions is reviewed and several proposed passivity models are outlined. Passivity in the non-aqueous solution of acetic acid-acetic anhydride was observed and characterized by voltage measurements. These measurements show a striking similarity to those in aqueous solution. This suggests that the same basic process is involved in both cases. Sulfuric acid, nitric acid, and chromium trioxide were used as passivating agents in the non-aqueous medium and their order is the same as in aqueous solution. The difference in the actual species in solution raises the question of the applicability of several of the passivity models outlined. Finally, suggestions are made for experiments to clarify the passivation process using non-aqueous passivated specimens.

TABLE OF CONTENTS

I.	INTRODUCTION	9
	A. HISTORICAL DEVELOPMENT	9
	B. THE PASSIVATING ANION	18
	C. THE ANODIC REACTION	19
II.	PASSIVITY MODELS	20
	A. COHEN'S MODEL	20
	B. EVANS'S MODEL	25
	C. CARTLEDGE'S MODEL	27
	D. BOCKRIS'S MODEL	30
	E. UHLIG'S MODEL	32
	F. FRANKENTHAL'S MODEL	33
III.	THE ROLE OF WATER IN THE PASSIVITY OF IRON	34
IV.	EXPERIMENTAL	37
	A. BACKGROUND	37
	1. Production of Passivating Media	39
	a. Nitric Acid (Acetyl Nitrate)	39
	b. Sulfuric Acid (Sulfoacetic Acid)	39
	c. Chromium Trioxide	40
	2. Construction of Electrodes	40
	a. Hydrogen	40
	b. Platinum	40
	c. Iron	41

B.	PROCEDURE	41
V.	RESULTS	43
VI	CONCLUSIONS	52
APPENDIX A	Experimental Characterization of Aqueous Passivity	56
APPENDIX B	Observation of Iron in Dioxane and Tetrahydrofuran Solutions of Fuming Nitric Acid	59
	BIBLIOGRAPHY	61
	INITIAL DISTRIBUTION LIST	64
	FORM DD 1473	65

LIST OF TABLES

I	Passivity in Aqueous Nitric Acid Solution	43
II	Passivity in Non-aqueous Solution of Fuming Nitric Acid in Acetic Acid-Acetic Anhydride with 2 Drops Sulfuric Acid Catalyst	44
III	Passivity in Non-aqueous Solution of Sulfuric Acid in Acetic Acid-Acetic Anhydride with 2 Drops Sulfuric Acid Catalyst	46
IV	Comparison of Effect of Addition of .05 Moles of Acid Passivator to 40 ml Acetic Acid-10 ml Acetic Anhydride Solution with 2 Drops Sulfuric Acid Catalyst	46
V	Comparison of Effect of Addition of .05 Moles of Acid Passivator to 40 ml Acetic Acid-10 ml Acetic Anhydride Solution with 2 ml of Trifluoroacetic Acid Catalyst	47

LIST OF DRAWINGS

Figure		
1	Potential-pH equilibrium diagram for the system nickel-water at 25° C	10
2	Schematic diagram for studying passivity potentiostatically from Frankenthal Ref. 4	13
3	Potential vs. current curve from Frankenthal Ref. 9	14
4	Energy vs. reaction coordinate diagrams from Evans Ref. 6	16
5	Cohen's model for the passive film from Nagayama and Cohen Ref. 8	21
6	Mechanism for passive film formation from Sato and Cohen Ref. 9	23
7	Sketch of Evans' model for passivity from Evans Ref. 6	26
8	Cartledge's adsorption Model from Cartledge Ref. 14	28
9	Relative effectiveness of passivators in non-aqueous solution	49
10	Relative effectiveness of passivators in non-aqueous solution	50

ACKNOWLEDGEMENT

The author wishes to thank his thesis advisor Professor Robert W. Helliwell for his guidance, and Professor Charles F. Rowell for his many helpful suggestions.

I. INTRODUCTION

A. HISTORICAL DEVELOPMENT

Metallic corrosion has long been the subject of empirical observations and correlations with little quantitative work done on the physical mechanisms and rate controlling steps involved in the corrosion process. An understanding of electrochemical processes has been used in a general way to explain how corrosion takes place. Less well understood is why, under certain conditions, corrosion does not take place although the metals are in an apparently corrosive environment.

In particular, knowledge of the mechanism of passivation is inadequate, either from a scientific or an engineering point of view. While passive alloys are very useful in many engineering applications, passivity must be regarded suspiciously in many other applications because breakdown of passivity often means catastrophic failure of a metallic structure. An understanding of passivity which would guide engineering design of alloys is needed.

Confusion has surrounded passivity from the earliest recognition of passive-active phenomena to the present time. Some of the confusion arises from the imprecise use of the term passivity. The ambiguity has arisen through explanations of passivity in terms of "protective coatings." Pourbaix gave support to the protective coating explanation of passivity by observing that metals at high pH were

Fig-1

Potential-pH equilibrium diagram
for the system nickel-water at 25°C

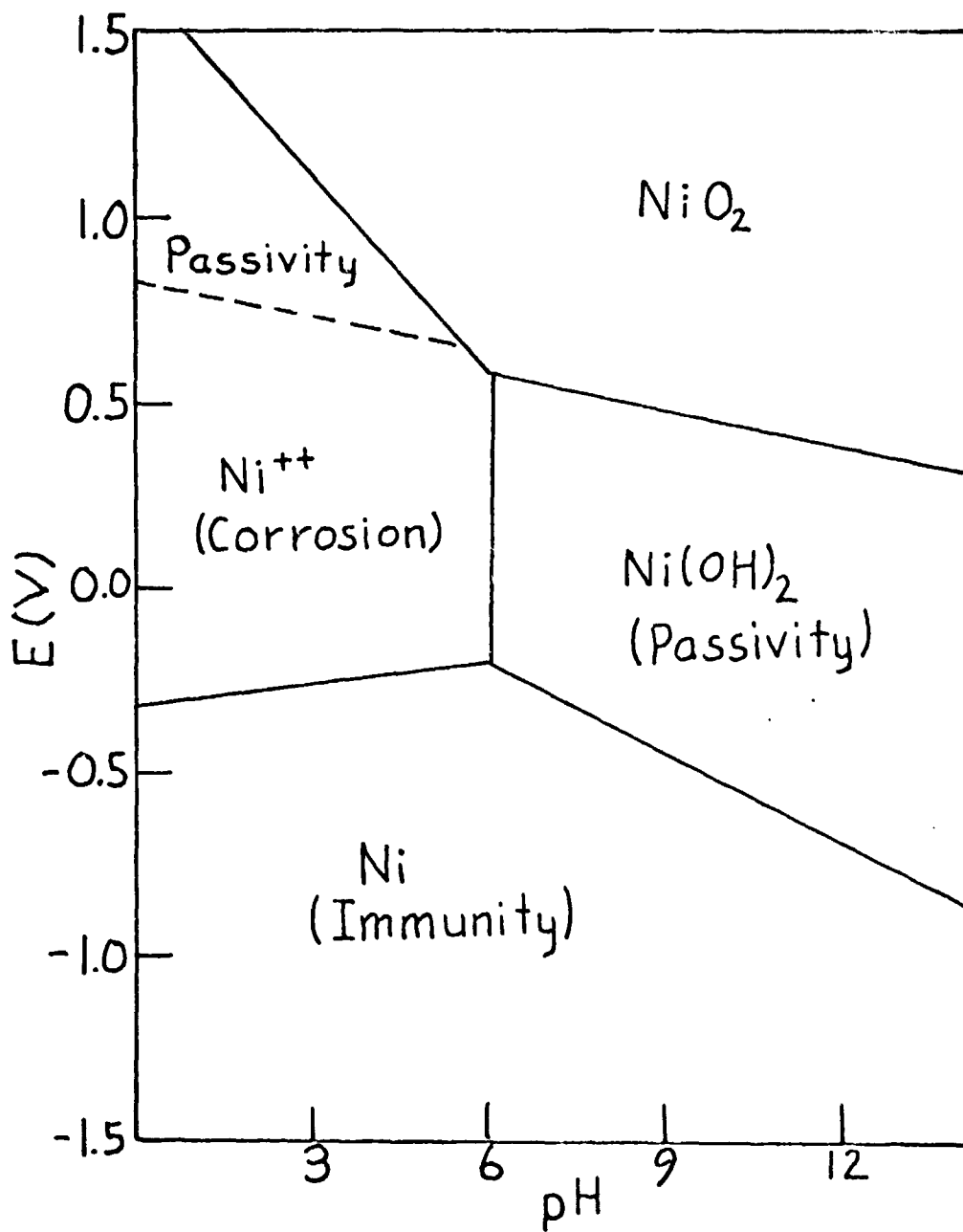

sometimes passive. The passivity coincided with the formation of insoluble metal hydroxide (or oxide) as shown in the potential-pH (Pourbaix) diagram of Figure 1 for nickel corrosion. Pure nickel corrodes in water at a potential greater than -0.4 volts at a pH less than 6. At pH greater than 6, corrosion does not take place due to the formation of insoluble Ni(OH)_2 instead of Ni^{++} . The Ni(OH)_2 or NiO forms a protective coating on the nickel which retards further corrosion. Pourbaix called this effect "passivity". This is not a proper characterization of passivity, because all metals do not become passive in this region of the Pourbaix diagram, although metal hydroxide (or oxide) formation may indeed take place.

It is also observed that if the potential is raised above 1.0 volts at a pH of 6 or less, corrosion is abruptly curtailed. This is not due to hydroxide or oxide formation as predicted by the Pourbaix diagram. Corrosion reduction, which occurs at either high pH or high potential, may be due to a resistive oxide film which retards corrosion without altering the driving force for the corrosion reaction, or may be due to a particular bonding situation, resulting from an "oxide" film on the metal, which reduces the driving force for the corrosion reaction. The latter effect is true passivity.

The work reported here is an effort to gain knowledge of true passivity.

The phenomenon of passivity has been known and studied since the turn of the nineteenth century. It was observed that iron corrodes

rapidly in dilute nitric acid giving off heat, gas, and brown corrosion products. When iron is immersed in concentrated nitric acid there is no visible reaction. Moreover, if the specimen is removed from the concentrated acid and quickly immersed in dilute nitric acid, there is no visible reaction. In 1836 Schonbein [Ref. 1] described the corrosion-resistant iron in the dilute nitric acid as "passive". About the same time Faraday showed that the passivity phenomenon was related to an electrochemical potential by measuring the small potential difference between passive iron and platinum, and comparing that to the large potential observed between active iron and the noble metal. By comparison of the low corrosion rate of amalgamated zinc in sulfuric acid and passive iron in nitric acid with the corresponding current densities of the two systems, Faraday concluded that the extremely low current density of the passive iron was the criterion for passivity, i. e., rate of oxidation process [Ref. 1].

Recently Carl Wagner¹ has clarified the meaning of a passive metal system in a useful way [Ref. 2]:

A metal is passive if, on increasing the electrode potential toward [more positive values with respect to the calomel electrode], the rate of anodic dissolution in a given environment under steady state conditions becomes less than the rate at some [more negative potential]. Alternatively, a metal is passive if, on increasing the concentration of an oxidizing

¹Wagner, C., Discussions at the First International Symposium on Passivity, 1957.

Fig - 2

Schematic diagram for Studying
Passivity Potentiostatically
From Frankenthal Ref [4]

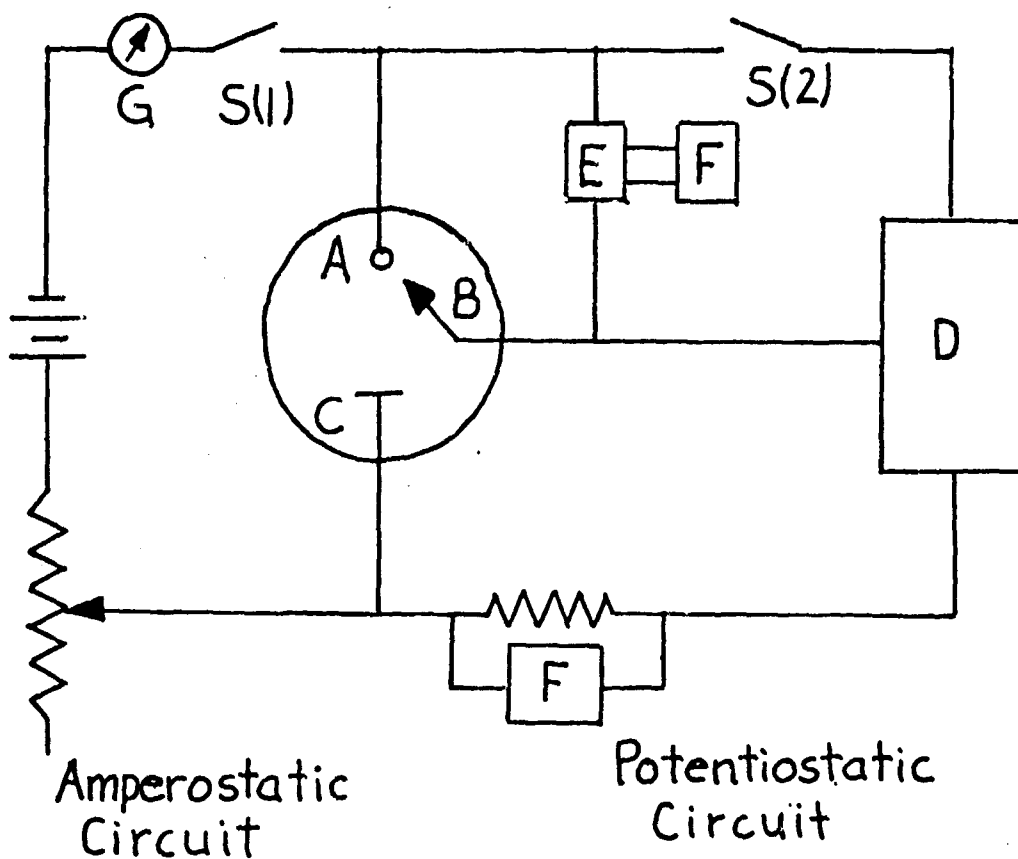

- | | |
|------------------------|------------------------|
| A. Test Electrode | B. Reference Electrode |
| C. Auxiliary Electrode | D. Potentiostat |
| E. pH Meter | F. Recorder |
| G. Ammeter | S. Switch |

Fig-3

Potential vs. Current Curve
From Frankenthal Ref [9]

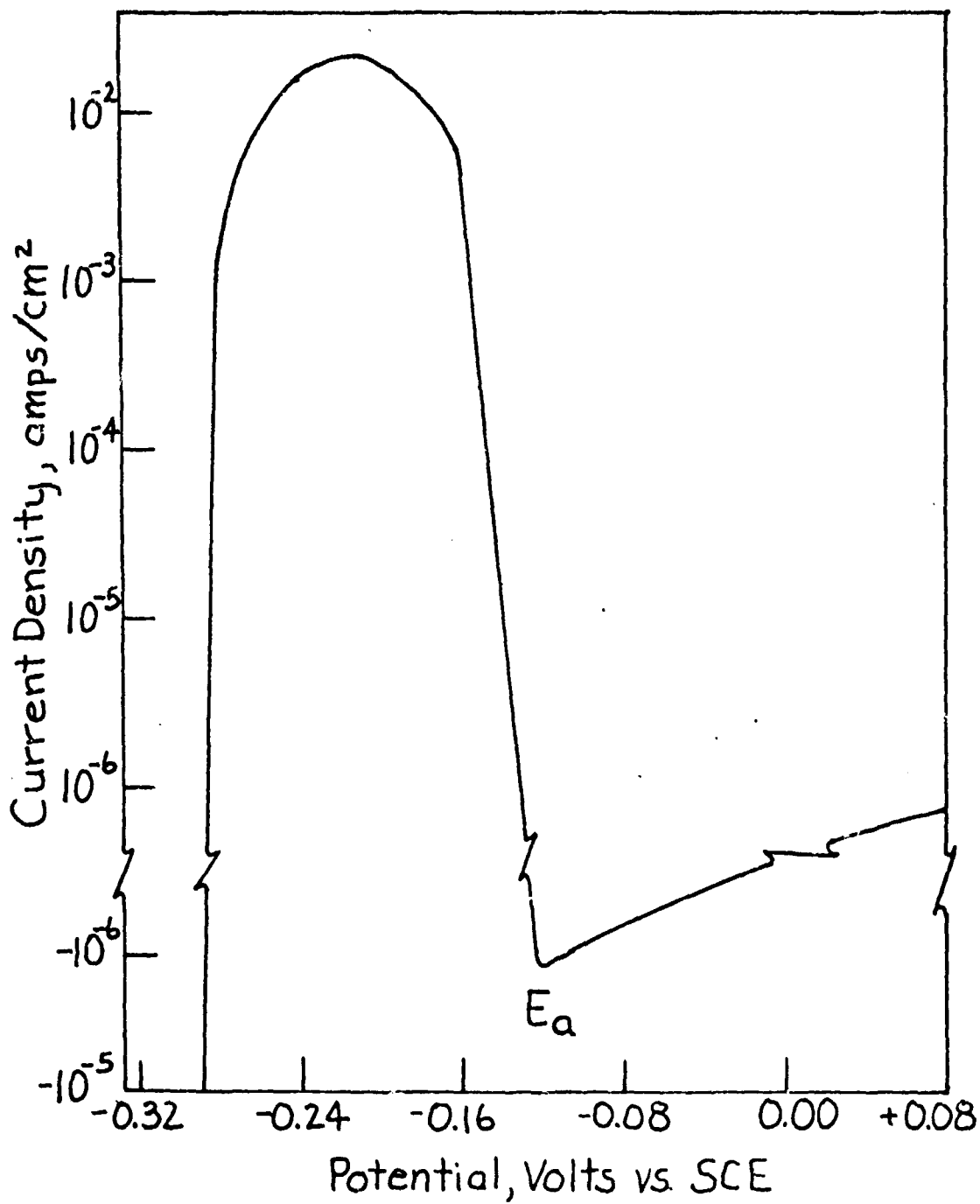

agent in an adjacent solution or gas phase, the rate of oxidization, in the absence of external current, is less than the rate at some lower concentration.²

Another system in which passivity is observed under different conditions was reported by Frankenthal [Refs. 3, 4, and 5] who has extensively studied the behavior of iron-chromium alloys in dilute sulfuric acid by potentiostatic and potentiodynamic techniques. In making potentiostatic measurements, a current is caused to flow between the steel electrode-platinum electrode couple which alters the potential of the steel electrode. By varying the current, any desired voltage can be maintained across the steel electrode and a standard calomel electrode (SCE) which has been placed in the cell as a reference electrode. The basic experimental arrangement is shown in Figure 2. The potential may be changed to more positive potentials and the corresponding currents observed. The resulting curve (Figure 3) shows clearly the effect of the phenomenon of passivity on current density and on corrosion rate. Starting from -.3 volts versus SCE, increasing the voltage to a more noble potential, the corrosion current density first rises until -.2 volts, then shows a dramatic decrease reaching its minimum at -.12 volts. Further increase in the applied potential increases the corrosion current. It should be noted that increasing

²Uhlig, H.H., Corrosion and Corrosion Control, p.58, Wiley, 1965.

Fig - 4

Energy vs. Reaction Coordinate Diagrams
From Evans Ref [6]

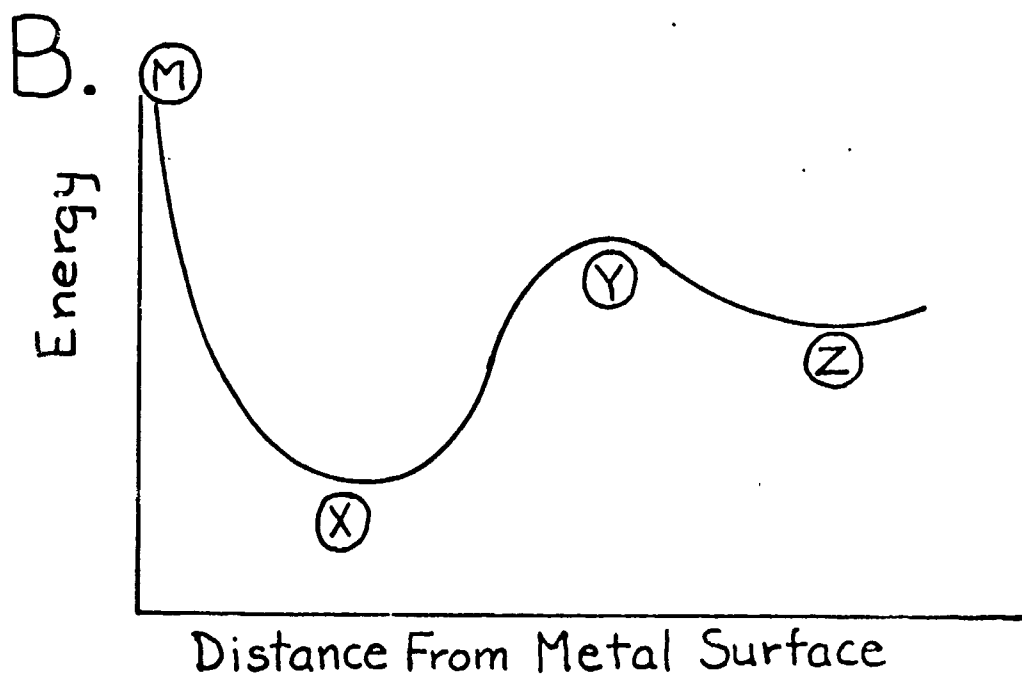
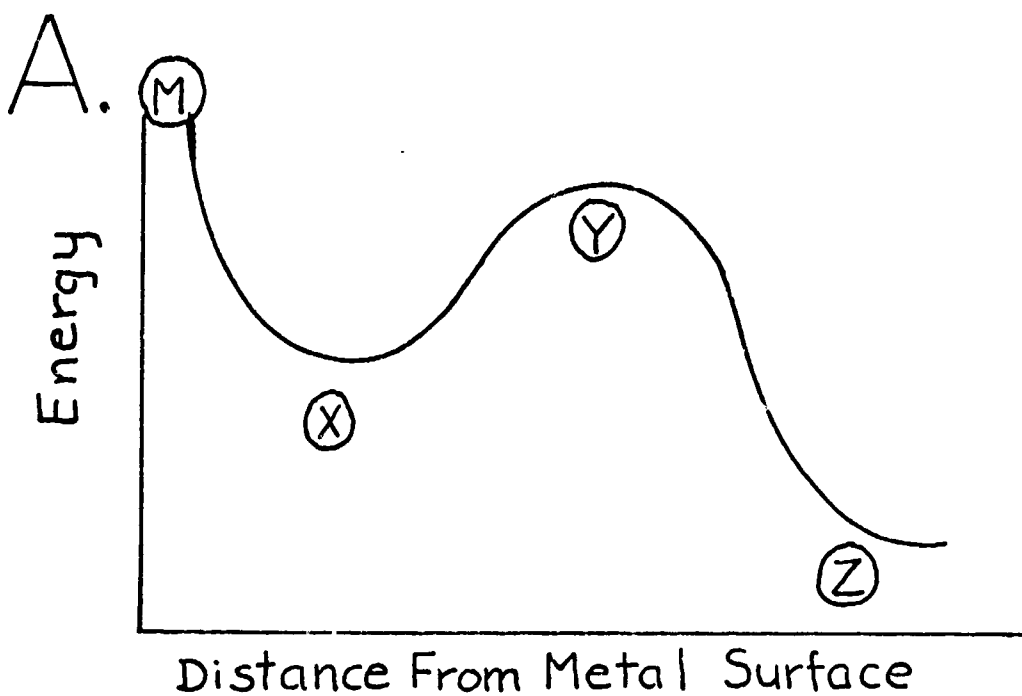

the sulfuric acid concentration in a similar solution does not cause the current to fall in this manner.

It is generally accepted that the same mechanism of passivation is present in both concentration-induced passivation, e.g., Faraday's method, and that produced by an externally-applied voltage, e.g., Frankenthal's method. Energy versus distance from surface plots (Figure 4) proposed by Evans [Ref. 6] show clearly how the connection between these two modes of passivation is made in accordance with his model of the mechanism of passivation which will be discussed later.

Figure 4A represents the situation of iron in dilute sulfuric acid. Iron ions removed from the surface (M) reach an energy minimum at (X) because this is the region corresponding to the negative portion of the electric double layer produced when negative ions or dipoles are adsorbed on an anodic portion of a metallic surface. The iron must pass over an energy maximum or positive region before reaching its lowest energy configuration as the solvated ion. In the case of sulfuric acid and iron, the position (X) corresponds to the layer of oxygen atoms of the sulfate ions adsorbed onto the surface; (Y) is the region behind this, occupied by sulfur atoms of high positive valence; and (Z) is solvated FeSO_4 . Because the iron ions are at a lower energy at position (Z), an external electromotive force (EMF) must be applied to make position (X) a lower energy configuration than (Z).

Figure 4B may be illustrated by using a potassium chromate solution. Iron ions reaching (Z) will be immediately precipitated as FeCrO_4 showing that position (X) is the lowest energy state and the iron ions will remain at (X). In this system there is no need for an externally-applied EMF because ions will tend to remain in their position of lowest energy; i.e., at (X), thereby reducing the corrosion rate.

B. THE PASSIVATING ANION

The phenomenon of passivity is brought about by the action of certain anions which are capable of initiating passivity by concentration or with the aid of externally-applied EMF. The study of this group of passivating anions has been centered around ions of the XO_4^{-n} type. Cartledge [Ref. 7] has studied the relative passivation effectiveness of various ions of the XO_4^{-n} type and the deleterious effect of added electrolytes. Using the pertechnetate ion (TcO_4^-) solution, passivity is attained at a much lower concentration than with solutions of molybdate, tungstate, or chromate. Additions of non-passivating anions such as chloride and sulfate caused a breakdown in passivity and a negative shift in the electrode potential of the iron. The results of this study show that the effect of the XO_4 sub-species in a non-aqueous solution of acetic acid and acetic anhydride is similar to that noted in an aqueous solution.

C. THE ANODIC REACTION

The reaction of nitric acid with iron produces both ammonium salts and nitrous acid along with nitrogen dioxide, nitric oxide, and nitrogen.

It is observed that the reaction of iron in dilute nitric acid starts slowly and becomes increasingly violent. Instead of entirely escaping from the liquid, the nitric oxide is retained by combining with the ferrous salts and forms a brown soluble nitroso compound, $\text{Fe}(\text{NO}_3)_2 \cdot \text{NO}$. The nitric oxide can then be re-oxidized by the nitric acid and thus re-enter the cycle thereby increasing the concentration of nitrogen dioxide and increasing the reaction rate. Immersion in concentrated nitric acid at first produces a reaction which quickly ceases as passivity takes over. Any reaction products are re-oxidized and the iron surface is cleared. These are the observed reactions associated with the passivity of iron in nitric acid.

Following are several general models or mechanisms suggested to explain this phenomenon. A section devoted to the role of water inclusion in the passive film is included because it is the intent of this paper to show that passivity can be observed in the absence of water. Non-aqueous studies can be useful in resolving the conditions for and mechanisms of passivity which must be considered as both theoretically and commercially valuable.

II. PASSIVITY MODELS

Several prominent corrosion researchers have proposed models to explain the phenomenon of passivity. The following models represent the different points of view concerning the mechanism of passivity.

A. COHEN'S MODEL

Nagayama and Cohen [Ref. 8] treat the anodically formed passive film like that obtained from

air oxidation of iron where the oxide is formed by a rearrangement of oxygen and the iron ions to form a lattice in which the oxygens form a face-centered cubic lattice with iron atoms fitted into octahedral and tetrahedral sites. The oxidation of magnetite to α - Fe_2O_3 and of β - Fe_2O_3 to the [defect] structure oxide takes place by diffusion of iron ions out of the lattice accompanied by oxidation to a higher valence state.³

Figure 5 shows the pictorial representation of the passive film structure. The anodic reactions involving the formation of the film in each of the three areas (I, II, III of Figure 5) corresponding to higher oxidation states of iron are:

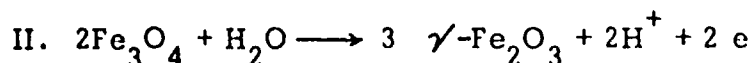
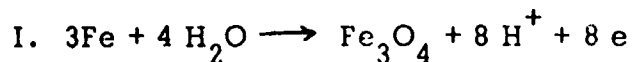

³ Nagayama, M. and Cohen, M., "The Anodic Oxidation of Iron in a Neutral Solution; I. The Nature and Composition of the Passive Film," Journal of the Electrochemical Society, v. 109, No. 19, p. 781, 1962.

Fig-5

Cohen's Model for the Passive Film
From Nagayama and Cohen Ref [8]

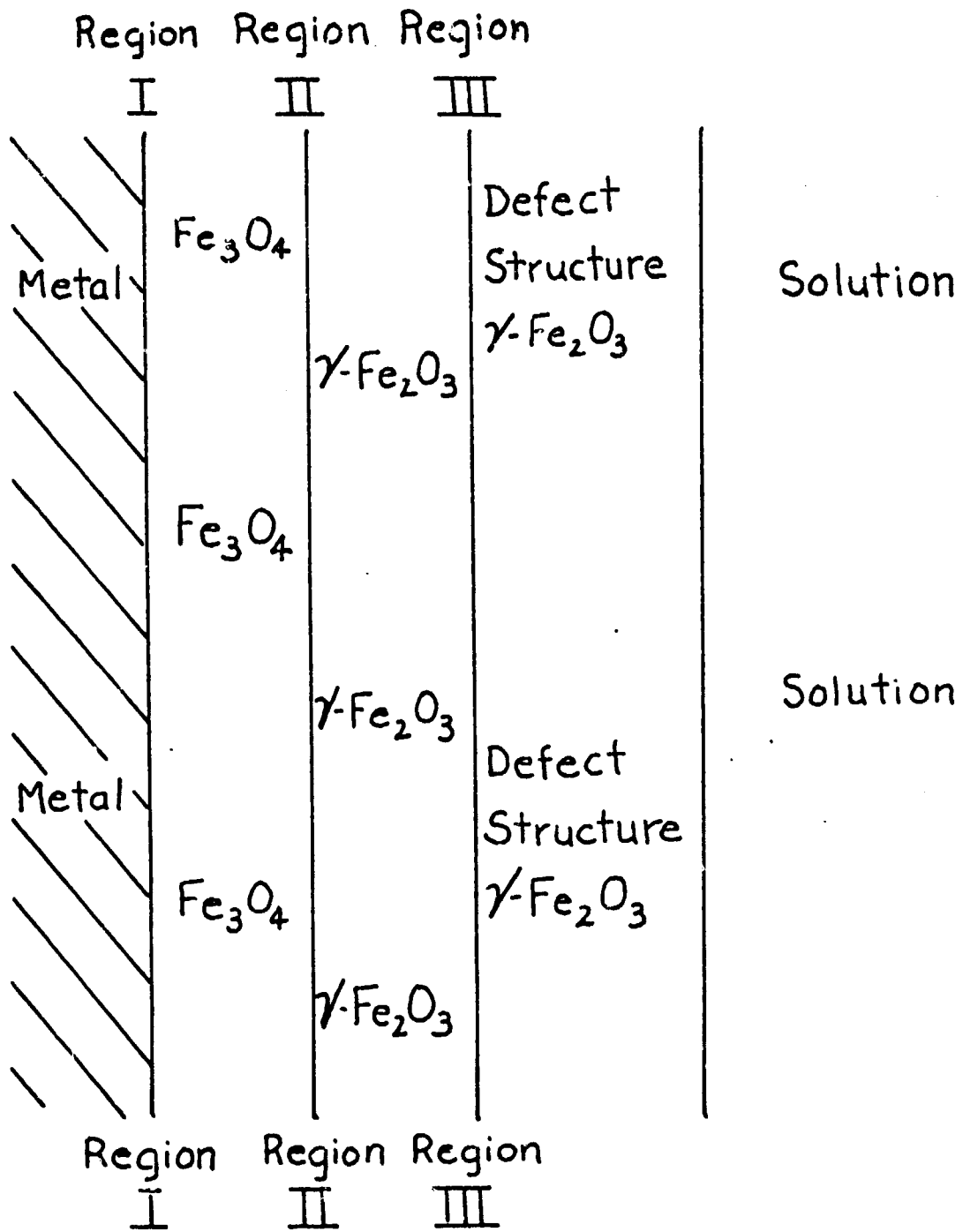

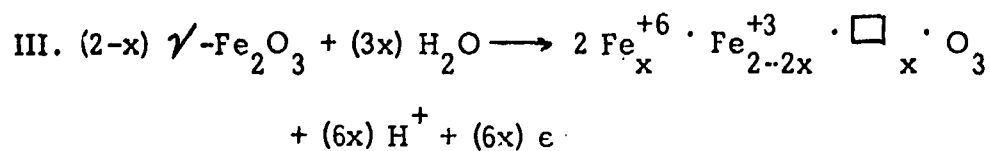

where \square represents a vacancy in the spinel structure of the $\gamma\text{-Fe}_2\text{O}_3$. Nagayama and Cohen also consider the possibility, in a highly oxidizing medium, of formation of $\gamma\text{-Fe}_2\text{O}_3$ directly from iron.

Reversing the process, the cathodic or film-destruction reactions are given as:

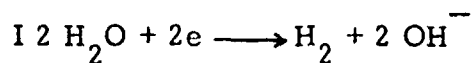
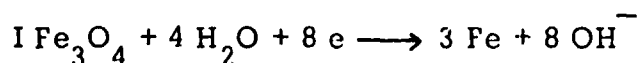
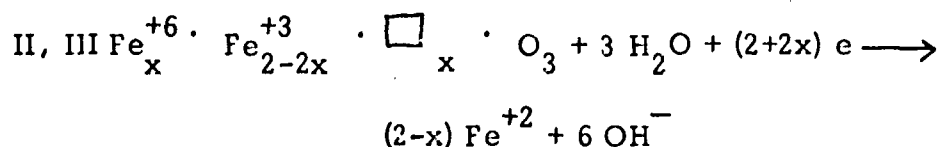

The film was found to be 10 to 30 angstroms in thickness in the passive potential region with the boundary between the first and second layers indistinct. The composition of the film is dependent upon the potential of passivation, the thickness of Fe_3O_4 , $\gamma\text{-Fe}_2\text{O}_3$, and the defect structure, all of which increase with increased potential.

In a later publication [Ref. 9] studying the kinetics of anodic oxidation, Sato and Cohen found that, in the steady growth region, the rate of film growth depends on film thickness and potential and obeys the rate law:

$$\text{rate} = i = k'e^{(\beta E - Q_T/B)} \quad (1)$$

Fig - 6
 Mechanism for Passive Film Formation
 From Sato and Cohen Ref [9]

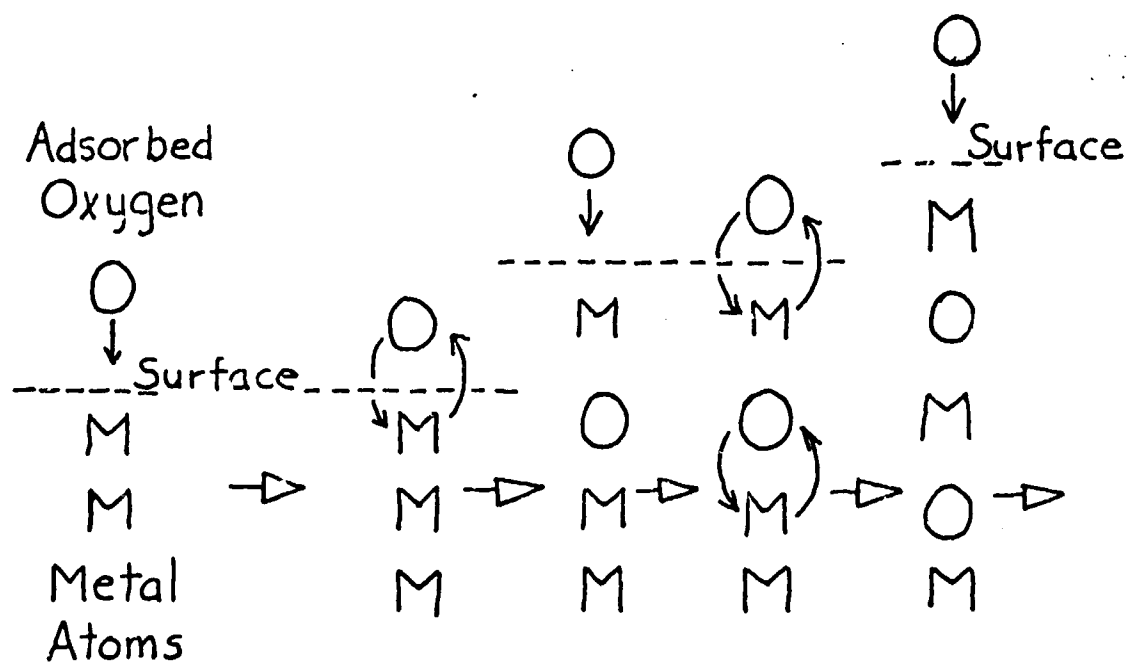

where k' , β , and B are constants, Q_T is the total charge accumulated in the film, and E is the activation energy.

A rate expression of the type observed [Eq. (1)] is found by assuming that the activation energy increases linearly with thickness. The mechanism postulated for film growth, with the activation energy increasing linearly with film thickness, involves the simultaneous place-exchange of oxygen and metal atoms as shown in Figure 6. This simultaneous oxygen and metal ion rotation mechanism was first proposed by Lanyon and Trapnell [Ref. 9] to account for the air oxidation of metals. An oxygen atom is adsorbed onto the metal surface, then exchanges places, possibly by rotation, with the adjacent metal atom. Another oxygen atom is adsorbed on the exterior metal atom and the two systems exchange simultaneously as shown in Figure 6. The process continues, and the number of rotating pairs and consequently the activation energy increases linearly with thickness. This mechanism describes film growth in the steady growth region.

In the initial stages [Ref. 10] there is an arrest in the potential during the oxidation that is associated with the formation of iron-ion vacancies (or excess oxygen ions) in the outer layer of the oxide (region III of Figure 5). As the concentration of vacancies increases in the outermost portion of the oxide, the rate of vacancy formation slows down and the transport of iron ions from the metal via exchange with oxygen takes over in the steady growth region.

In summary, the mechanism for passive film formation consists of two steps:

1) Upon the first application of current, a charge is established at the oxide-solution interface which leads to the formation of iron-ion vacancy-electron pairs, and the entrance of oxygen ions into the lattice.

2) This process is superseded after a certain amount of time by the place-exchange mechanism of oxygen and iron-ion pairs until the thickness of the film causes the activation energy for this process to be sufficiently large so that another mechanism, such as cation diffusion via vacancies, becomes favored.

B. EVANS'S MODEL

U. R. Evans [Ref. 6] considers passivation of an iron sample after exposure to air. This exposure produces an oxide film over large portions of the sample. In dilute copper nitrate solution, copper will be plated out on cathodic areas around the discontinuities in the oxide film, while ferrous ions will go into solution at the discontinuities by anodic reaction. If, however, the solution is concentrated a large number of iron cations must go into solution to keep up with the maximal rate of copper deposition. As shown in Figure 7 the nitrate ions are driven against the anode by the potential gradient with the most negative portions of the ions (the oxygen atoms) closest to the surface. The ferrous ions going into solution must penetrate the high-energy barrier at \textcircled{Y} . In a concentrated solution the requisite number of high-energy

Fig-7

Sketch of Evans' Model for Passivity
From Evans Ref [6]

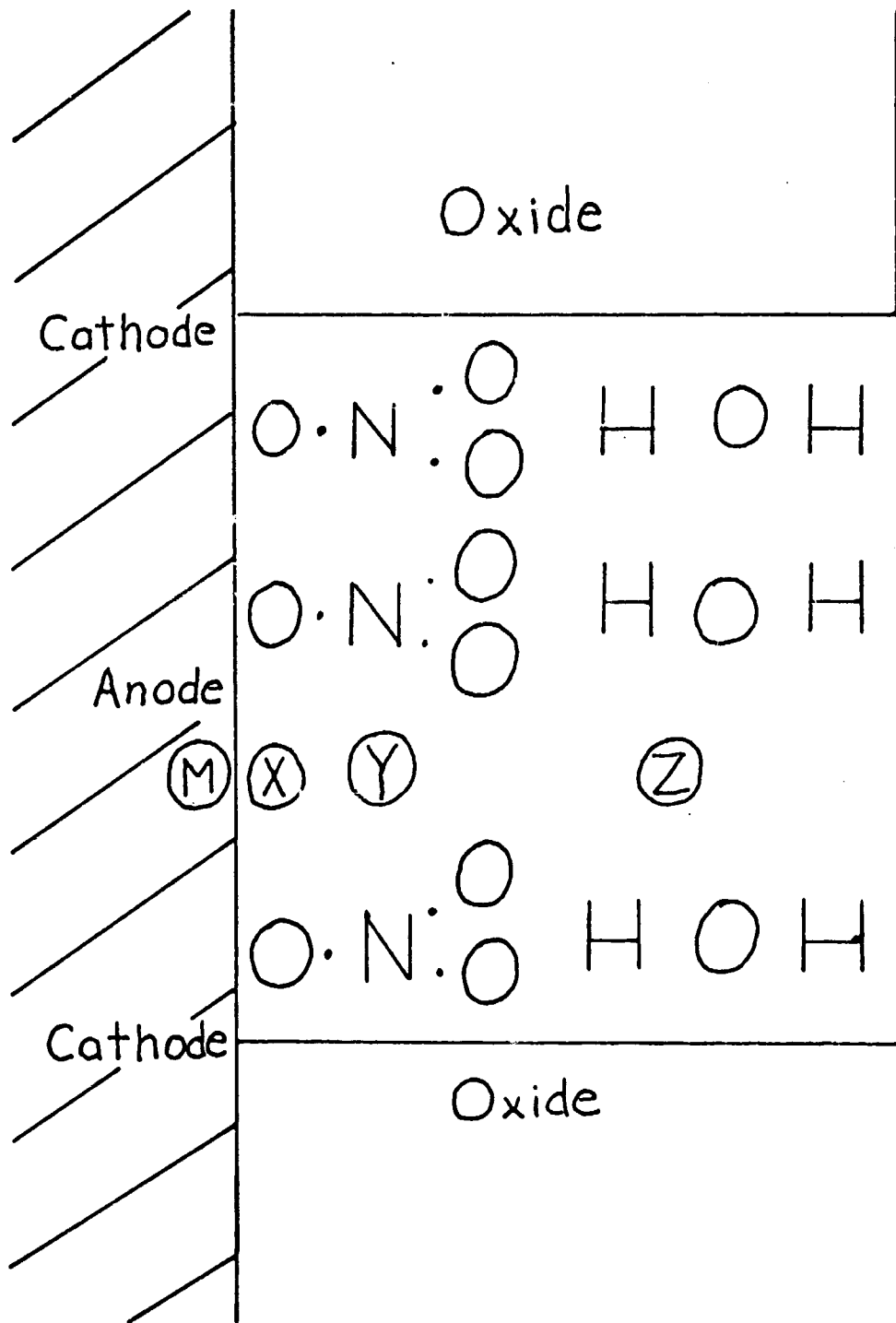

ions will not be able to surmount this barrier to get into solution at position (Z) . Therefore, they will remain at (X) along with the oxygen atoms released by the nitrate ions during the anodic reaction and form an oxide layer which progressively thickens until ferrous ions are no longer able to penetrate this film to attain solvation. This oxide formation is to be expected at high current densities where only a reaction demanding a low activation energy can occur.

In a sodium hydroxide solution the hydroxide ions are also driven against the metal surface by the potential gradient. Evans points out the basic difference between this and the preceding medium. In the copper nitrate solution the point of lowest energy is the solvated ferrous ions, whereas in the sodium hydroxide solution the point of lowest energy is at (X) . Therefore, the cations will tend to remain at (X) and there is no need for a high current density to obtain passivity, and no need for an externally-applied EMF.

C. CARTLEDGE'S MODEL

After experimentation with the perrhenate ion (ReO_4^-), which is structurally very similar to the passivating pertechnetate ion, and finding it to be non-passivating, G. H. Cartledge [Refs. 11, 12, and 13] proposed a theory based on the internal polarity of the X-O bonds of the XO_4^{-n} -type ions. The passivity exhibited by the pertechnetate ion arises from reversible, dynamic adsorption of the tetrahedral ion

Fig - 8
Cartledge's Adsorption Model
From Cartledge Ref [14]

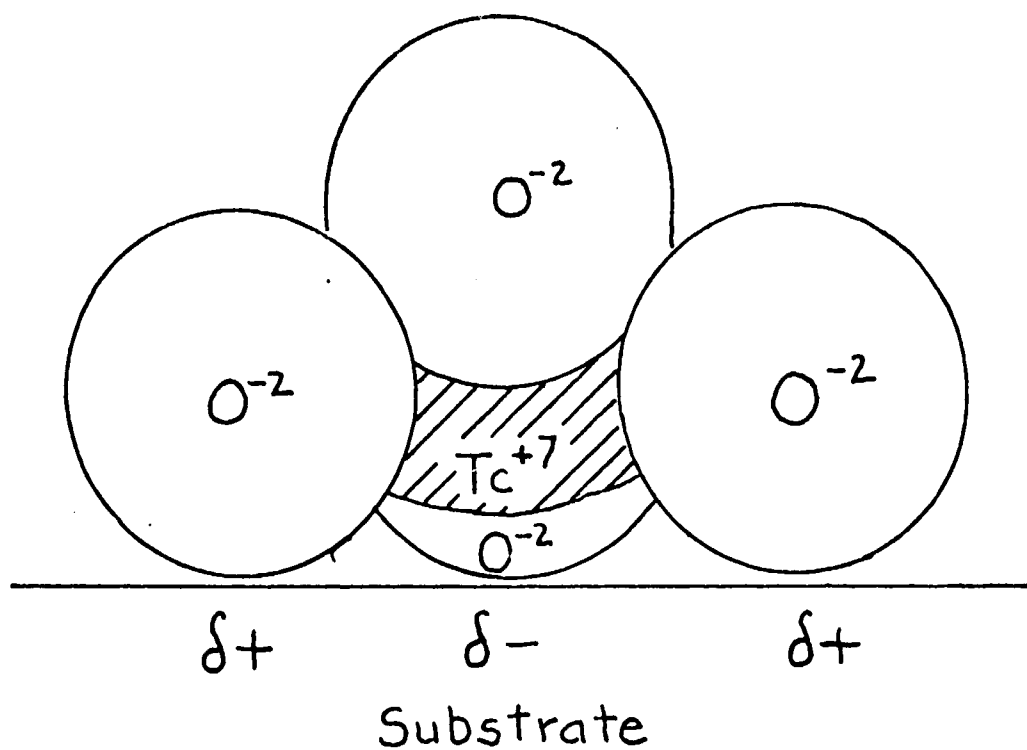

on the interface, whereby the surface undergoes an electrostatic polarization under the influence of the intra-ionic polarity of the inhibitor particle."⁴ Since the central technicium atom has a charge of +7 the bonds will be highly polar and a mirror charge ($\delta +$, $\delta -$) will be produced on the substrate (Figure 8). The differing intra-ionic polarity is responsible for the specific passivating capabilities of each ion. The ions will tend to be adsorbed more strongly where the greatest negative charge can be induced on the substrate, or the most cathodic areas. This would effectively increase the activation energy for cathodic reaction. Specifications for passivation by this process are listed by Cartledge [Ref. 14]:

- 1) An ion with a geometry suitable for adsorption;
- 2) High formal charge on the central atom and a high degree of internal polarity;
- 3) An ion with a redox potential low enough or an activation energy high enough to prevent rapid reduction of the ion;
- 4) A solution containing a low enough concentration of competing ions.

⁴Cartledge, G.H., "The Mechanism of the Inhibition of Corrosion by the Pertechnetate Ion. III. Studies of the Perrhenate Ion," Journal of Physical Chemistry, v. 60, pp. 34-35, January 1956.

It is stressed that "specific interactions involving the internal electrical properties of the adsorbed ion are responsible for the action of inhibitors of the type under consideration."⁵

In a later publication [Ref. 13] Cartledge distinguishes between two types of passivators according to the role of oxygen. The first type characterized by nitric acid is considered to passivate solely because of its favorable oxidizing power with no specific effects due to adsorption. The second type, characterized by nearly all of the XO_4^{-n} - type passivators, becomes an effective passivator through cooperation with oxygen and an alteration of the kinetics of the cathodic reaction. Included also are the organic passivators phthalate and benzoate ions which have no oxidizing power of their own and show no passivation in the absence of oxygen. This role of oxygen is deduced from experiments showing that oxygen at atmospheric pressure or less is reduced on the passive surface at a considerably faster rate than either chromate or pertechnetate ions [Refs. 15 and 16].

D. BOCKRIS'S MODEL

From the ellipsometric study of passivity of nickel, J. O'M. Bockris, A. K. N. Reddy, and B. Rao [Ref. 17] have developed a two-stage mechanism for passivity.

⁵Ibid., pp. 35-36.

A film formation was noted by a change in the index of refraction of the surface of nickel without an accompanying decrease in dissolution. This change is designated as the precursor film and is a necessary but not sufficient condition for passivity. A second potential is reached where the current begins to fall. This is the activation potential and is accompanied by an increase in the electrical conductivity of the film.

The precursor film is a thick film, on the order of 45 angstroms, and is formed at a potential distinctly negative with respect to the activation potential. It is the conversion of this precursor film to a semi-conductor that constitutes the essential step in attaining passivity. The increase in electrical conduction decreases the field gradient across the film and prevents ion transport through the film, thereby reducing metal dissolution. This is the passive state.

The point is also made in Bockris's article that attempts to determine the thickness of the film galvanostatically actually measure the reduction of chemisorbed oxygen on the film rather than reduction of the passive film on the metal surface. Ellipsometric evidence of a film even after reducing the potential to the point of hydrogen evolution supports this statement.

The essential idea here is that the conversion of the film from an ionic to an electronic conductor is the cause of passivity.

E. UHLIG'S MODEL

H. H. Uhlig [Ref. 18] advances the proposal that passivation "involves a momentary rapid reduction of the passivator at cathodic areas, accompanying simultaneous polarization of anodic areas beyond the passivating potential, and formation of the passive film. . . . [which may consist of] adsorbed oxygen or oxygen complexes resulting from discharge of OH^- or from oxidation of water" [Ref. 18].⁶ The similar passivation potentials for the same substrate under the influence of several different passivators suggests that a similar film is formed in these cases. The adsorption of the passivating ion takes place on the film rather than on the metal itself, thereby stabilizing the film thermodynamically. The small amount of passivating ions as reduction products which remain on a sample after washing are not, then, the cause of passivity, but instead, the by-products of the initial cathodic reaction accompanying passivity.

Evidence in support of this theory [Ref. 1] shows that passivated metals are transition metals with d-shell electron vacancies. These unpaired electrons account for strong bond formation especially with paramagnetic oxygen. High heats of sublimation favor adsorption rather than a reaction producing an oxide film. The characteristic

⁶Spitsin, V.I., et al., "Investigation of Inhibiting Properties of the Pertechnetate Ion," Corrosion, v. 21, p. 219, July 1965.

Flade potential associated with passivation on iron is too noble by about 0.6 volts to be explained by any known oxide in equilibrium with iron.

In summary the adsorption theory amounts to anodic polarization of the substrate by an adsorbed oxide film which is thermodynamically stabilized by a small amount of the passivating ion.

F. FRANKENTHAL'S MODEL

R. P. Frankenthal [Ref. 5] sees the passivity process as the result of two types of films. The first, an adsorbed film, is responsible for the initiation and maintenance of passivity near the activation potential E_a . This activation potential is defined [Ref. 19] as the potential corresponding to the initial rise in current upon going from the passive region into the anodic loop (see Figure 3). At potentials higher than 0.2 volts above E_a this film is no longer an effective passivator and an oxide film is required to initiate and maintain passivity. Near E_a dissolution takes place by direct transfer of ions from metal to solution. In the presence of the secondary oxide film, the dissolution is limited by diffusion through the oxide film against the potential across that film. In the intermediate potential range, the adsorbed film initiates passivity, and the steady-state oxide film is responsible for the final decrease in current.

III. THE ROLE OF WATER IN THE PASSIVITY OF IRON

The presence of bound water in passive films was first noted by Rhodin [Ref. 20] by analyzing the film stripped from iron.

G. Okamoto, et al., [Ref. 21] measured the amount of bound water in the passive films on stainless steels, without stripping the film, using microthermogravimetric techniques. By plotting the weight loss of the passivated specimen (found to be 90% water) versus temperature, the following observations were noted:

- 1) There is a larger amount of bound water when the sample is anodically passivated for 60 minutes than for a sample passivated for 1000 minutes.
- 2) The amount of bound water in films formed at over-passive potentials is greater than the amount formed in the passive region.
- 3) Assuming a film of Fe_2O_3 , the proportion of bound water was found to be between 27% and 48%.
- 4) The decrease in time required for self activation of the sample with an increase in heat-treatment temperature, was attributed to an increase in vacancies due to the desorption of water.

Work done by Okamoto, et al. [Ref. 22], shows the existence of bound water in the passive film and leads the authors to suggest

"that the bound water in the film plays an important part in the stability of the passive film against corrosion."⁷

Bloom and Goldenberg [Ref. 23] refer to electron diffraction and cathodic behavior evidence for the existence of γ -Fe₂O₃ in the passive film of iron. This γ -Fe₂O₃ has a spinel-line structure and magnetic properties similar to Fe₃O₄. On the basis of anodic reactions and rate data taken largely from Cohen, et. al. (see Passivity Theories -- Cohen), the film is thought to be comprised basically of two layers. The first, in contact with the metal, is Fe₃O₄ which is electronically conductive. This layer is covered by an insulating film of γ -Fe₂O₃.

The γ -Fe₂O₃ has, in itself, been the object of considerable study. Bloom and Goldenberg list the salient facts concerning γ -Fe₂O₃ which show the relationship of γ -Fe₂O₃ to the role of water in passivity [Ref. 23]:

1) Oxidation of Fe₃O₄, prepared by precipitation from aqueous solution, gives a series of ferrimagnetic products in which Fe⁺² is oxidized to Fe⁺³ accompanied by a structural change.

2) The end product (γ -Fe₂O₃), which is obtained after the elimination of all ferrous ion, cannot be generated in the absence of water, and cannot be de-hydrated without conversion to α -Fe₂O₃

⁷Okamoto, G. and Shibata, T., "Desorption of Tritiated Bound-water from the Passive Film Formed on Stainless Steels," Nature, v. 206, p. 1350, 26 June 1964.

(non-magnetic). (If this is true, the passive film as we know it on iron cannot exist in the absence of water because the insulating layer of γ -Fe₂O₃ cannot be produced under these conditions.)

3) The reaction of α -Fe₂O₃ with hydrogen gives a product having the physical properties of γ -Fe₂O₃ but with the formula HFe₅O₈.

4) The γ -Fe₂O₃ produced from wet Fe₃O₄ gives an X-ray diffraction similar to LiFe₅O₈, a spinel. The formula for γ -Fe₂O₃ is therefore given as HFe₅O₈.

Further evidence for this formula was presented by Yolken, et. al. [Ref. 24], who found hydrogen in the outer layer of the passive film.

IV. EXPERIMENTAL

A. BACKGROUND

Several preliminary passivity experiments were performed on iron in aqueous environments. The purpose of these experiments was to produce passive films, note the conditions under which they formed in nitric acid solutions, and to perform experiments on film production while altering certain physical variables. Inasmuch as they do not bear directly upon the topic of passivity in non-aqueous environments, detailed descriptions of the experiments and the results are relegated to Appendix A.

Producing a water-free environment in which passive films could be studied posed an experimental problem which is the primary objective of the research effort reported here.

The passivity models described in Section II are based upon data derived from water-solution experiments. Studies of passivity in non-aqueous environments were undertaken to obtain data which would help clarify the essential processes which result in passivity.

By comparison of aqueous and non-aqueous passivating media, it was possible to discount certain portions and implications of the present models for passivity. Attainment of passivity in a non-aqueous solution eliminates the necessity of water solution in the stabilization of the passive film, and enables passivity to be studied under a

completely different set of conditions. Water-solvated ionic interaction can be eliminated as essential to the passivation process, and water can be eliminated as the source of oxygen and hydrogen [Ref. 24] in the passive film.

Tetrahydrofuran, acetic acid-acetic anhydride, and 1,4-dioxane were selected as non-aqueous solvents worthy of investigation as media in which passivation experiments could be performed.

The 1, 4 dioxane was used for a series of experiments, and was prepared in a highly anhydrous form. However, contact with the atmosphere during passivity experiments resulted in introduction of water into the liquid. For this reason, the experimental evidence of passivity formed in 1, 4 dioxane could not be related to the amount of water present. The preparation, data, and behavior of the 1, 4 dioxane passivating system was considered indeterminate, so the results were not of sufficient importance to report here, but do appear in Appendix B. The use of tetrahydrofuran as a passivating-medium solvent led to indeterminate results which also are reported in Appendix B. It should be noted that 1, 4 dioxane and tetrahydrofuran form explosive solutions with fuming nitric acid and extreme care must be exercised when working with these reagents.

The powerful nitrating agent, acetyl nitrate, in a non-aqueous solution with acetic acid-acetic anhydride was suggested [Ref. 25] and subsequently tested. The acetic acid-excess acetic anhydride medium is rigorously anhydrous with the addition of an acid catalyst.

Sulfuric acid and trifluoroacetic acid [Ref. 25] were used on separate occasions, and both were found to be effective catalysts for the acetic anhydride-water reaction.

1. Production of Passivating Media

Three inorganic passivators were studied and the relative effectiveness of each was evaluated:

a. Nitric Acid (Acetyl Nitrate)

The addition of nitric acid to acetic anhydride produces acetyl nitrate and acetic acid:

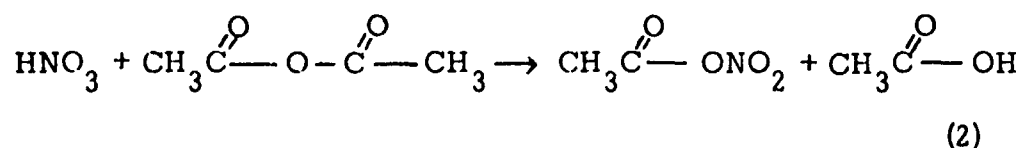

Acetyl nitrate is a powerful nitrating and oxidizing agent. Formation of acetyl nitrate prevents nitric acid from effectively catalyzing the acetic anhydride-water reaction because the hydrogen ion concentration is diminished by this reaction.

Solutions of acetyl nitrate were found to be explosively unstable in concentrations greater than 2.0 ml of nitric acid in 50 ml acetic acid-acetic anhydride solution. Care was taken to add reagents slowly (hypodermic syringe) with cooling and stirring. The solutions were immediately discarded after use.

b. Sulfuric Acid (Sulfoacetic Acid)

The addition of sulfuric acid to acetic anhydride forms sulfoacetic acid [Ref. 26]:

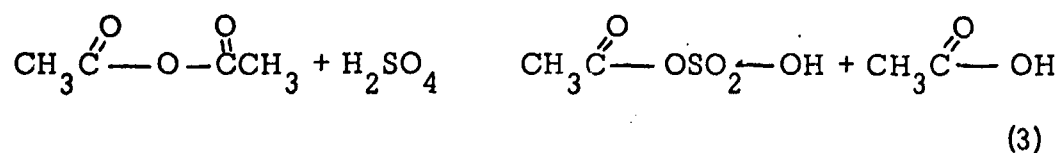

c. Chromium Trioxide

Addition of chromium trioxide (CrO_3) to acetic anhydride forms chromyl acetate $(\text{CH}_3\overset{\text{O}}{\parallel}\text{C}-\text{O})_2\text{CrO}_2$ after five hours [Ref. 26]. The suspension of chromium trioxide in glacial acetic acid (Fieser reagent) is a strong oxidizing agent [Ref. 27]. It was found that about 0.02 moles of chromium trioxide formed a saturated solution in the 40 ml acetic acid-10 ml. acetic anhydride medium used. Each chromium trioxide solution was made by stirring in 1.26 grams of CrO_3 to form the saturated solution.

2. Construction of Electrodes

a. Hydrogen

The hydrogen electrode was constructed from a four-inch test tube with a hole in the bottom to allow electrical contact to be made with a freshly-platinized platinum electrode. Hydrogen was bubbled over the partially immersed electrode surface by a suitably attached glass tube connected to a tank of hydrogen. The electrode was kept immersed in an acid-catalyzed solution of 40 ml. acetic acid-10 ml. acetic anhydride immediately before use.

b. Platinum

The platinum electrode was a freshly-platinized platinum strip 9/16 inch wide.

c. Iron

Armco iron electrodes (1" x 1" x 1/8") were used in all experiments. These were annealed at 700° F for three hours. Before each measurement, the electrodes were etched thoroughly in dilute nitric acid and immediately rinsed with Karl Fischer Grade anhydrous methanol and put in a desiccator for at least a half hour.

B. PROCEDURE

Solutions were prepared by adding measured amounts of acetic acid, acid catalyst, passivator and acetic anhydride respectively. All chemicals used were analytical reagent grade unless otherwise specified. Solutions catalyzed by sulfuric acid and trifluoroacetic acid showed no detectable water using Karl Fischer Reagent and conductometric titration with acetic acid [Ref. 28]. Karl Fischer Reagent could not be used to titrate the acetyl nitrate solutions because the iodine complex was oxidized by the acetyl nitrate as well as by water. Conductometric titrations using a Barnstead conductivity bridge (model PM 70 CB) showed clearly the effect of the presence of water in the acetyl nitrate solution. When water was present there was a continuous decrease in the conductivity of the solution. After the water had reacted completely, the conductance remained constant and then increased linearly with additions of acetic anhydride [Ref. 28]. This behavior of the conductance measurements was used to show the absence of water and was checked by titrating a solution of 40 ml acetic acid-10 ml.

acetic anhydride plus catalyst with Karl Fischer Reagent before conductivity stabilization and immediately after. Before stabilization, the solution was found to contain small amounts of water; and after, it contained none. The solutions catalyzed by the addition of two drops of sulfuric acid were found by either technique to be anhydrous immediately after mixing. Those catalyzed with trifluoroacetic acid contained no detectable amounts of water after approximately eight minutes. Passivity measurements were not made in these solutions until at least one half hour after preparation. The solutions were put in a desiccator immediately after preparation and individually covered with watch glasses.

When ready for measurements, the solutions were removed from the desiccator and hydrogen and platinum electrodes were immersed quickly. After reaching equilibrium (about one minute) voltage and current measurements were taken with a Keithly vibrating reed electrometer (model 602). (Unsteady readings were encountered in making hydrogen electrode versus platinum electrode measurements due to the presence of small hydrogen bubbles from the hydrogen electrode.) The platinum electrode was then removed and the iron electrode quickly immersed and similar measurements recorded. A steady reading was reached quickly with the iron electrode but a slow positive drift was noted perhaps due to corrosion at the waterline from adsorbed water.

V. RESULTS

The data presented represents three independent experimental measurements on the solutions described. Reproducibility was strict to within one significant figure in voltage values and to within a factor of two times 10^{-6} for current measurements. The important results of this study lie not in the accuracy of the individual measurements, but in the marked passive trends which were well above experimental or reproducibility errors.

Table I

Passivity in Aqueous Nitric Acid Solution

ml HNO ₃	ml H ₂ O	H-Pt (volts)	H-Pt (amps)	H-Fe (volts)	H-Fe (amps)
0	50	+ .7	8×10^{-5}	- .15	4×10^{-6}
.5(fuming)	50	+ .01	1×10^{-4}	-1.0	2×10^{-2}
5.0	45	+ .5	6×10^{-4}	- .9	3×10^{-2}
10.0	40	+ .5	4×10^{-4}	-1.0	5×10^{-2}
20.0	30	+ .1	1×10^{-3}	- .9	7×10^{-2}
30.0	20	+ .006	1×10^{-4}	- .9	6×10^{-2}
40.0	10	+ .006	1×10^{-4}	- .9	7×10^{-2}
50.0	0	+ .02	3×10^{-4}	- .3	1×10^{-3}
50.0(90%)	0	+ .06	4×10^{-4}	- .4	2×10^{-3}

Table II

Passivity in Non-aqueous Solution of Fuming Nitric Acid
in Acetic Acid-Acetic Anhydride with
2 Drops Sulfuric Acid Catalyst

ml HNO ₃	ml Acetic acid	ml Acetic anhydride	H-Pt (volts)	H-Fe (volts)
0	40	10	-.06	-.75
.02	40	10	+.03	-.28
.05	40	10	+.02	-.25
.1	40	10	+.03	-.34
.2	40	10	+.05	-.36
.3	40	10	+.02	-.36
.5	40	10	+.04	-.32
.6	40	10	+.03	-.32
1.0	39	10	+.04	-.24
2.0	38	10	+.04	-.30
5.0	30	15	+.06	-.34
10.0	10	30	+.09	-.48
15.0	0	35	+.11	-.45

Table I and Table II show that passivity is obtained in both aqueous and non-aqueous solutions. Passivity in aqueous nitric acid solution was characterized by a change in hydrogen-iron (H-Fe) potential from -.9 to -.3 volts. This was accompanied by a very small increase in hydrogen-platinum (H-Pt) potential from +.006 to

+0.02 volts. It is therefore obvious that there was a change in the solution that has a particular effect on iron. This effect was passivity.

In aqueous solution the drop in voltage with respect to hydrogen was accompanied by a decrease in the current measured to one-fifteenth of its original value. Simple observations showed that the corrosion rate dropped by more than a factor of 15 because the iron remained bright without corrosion in the concentrated nitric acid solution almost indefinitely, while the solution of 30 ml of 70% HNO_3 and 20 ml H_2O dissolved an entire electrode very quickly. Due to the lack of potentiostatic equipment, accurate corrosion-current measurements were unattainable, and current measurements are listed as data for comparison only.

Table II shows the behavior of iron and platinum in non-aqueous acetyl nitrate solution with sulfuric acid as a catalyst. Passivity occurred at very low concentrations of acetyl nitrate and was observed by a voltage drop from -.75 to -.28 volts. The increase in platinum voltage was less than .1 volt. There was a slow rise in the potential of iron with respect to hydrogen with increasing concentration until the medium was 50% acetyl nitrate. This is the stoichiometric limitation for acetyl nitrate prepared in this manner.

Table III shows data for the titration of the non-aqueous medium with sulfuric acid. It was observed that, as in aqueous solution, there was no potential drop with added sulfuric acid. The potential progressively rose and no passivity occurred.

Table III

Passivity in Non-aqueous Solution of Sulfuric Acid in
Acetic Acid-Acetic Anhydride with 2 Drops
Sulfuric Acid Catalyst

ml H_2SO_4	ml Acetic acid	ml Acetic anhydride	H-Pt (volts)	H-Fe (volts)
0	40	10	-.06	-.75
1.0	39	10	-.01	-.75
2.0	38	10	+.02	-.77
10.0	30	15	+.06	-.85
15.0	0	35	+.06	-.90

Table IV

Comparison of Effect of Addition of .05 Moles of Acid
Passivator to 40 ml Acetic Acid-10 ml Acetic Anhydride
Solution with 2 Drops Sulfuric Acid Catalyst

Acid	H-Pt (volts)	H-Pt (amps)	H-Fe (volts)	H-Fe (amps)
---	-.06	4×10^{-7}	-.76	7×10^{-6}
HNO_3	+.05	9×10^{-7}	-.28	3×10^{-6}
H_2SO_4	-.01	3×10^{-6}	-.80	9×10^{-4}
CrO_3	+.3	8×10^{-6}	+.90	2×10^{-6}

Table V

Comparison of Effect of Addition of .05 Moles of Acid
Passivator to 40 ml Acetic Acid-10 ml Acetic Anhydride
Solution with 2 ml of Trifluoroacetic Acid Catalyst

Acid	H-Pt (volts)	H-Pt (amps)	H-Fe (volts)	H-Fe (amps)
---	+ .3	2×10^{-7}	- .06	2×10^{-8}
HNO ₃	+ .006	5×10^{-9}	- .35	5×10^{-7}
H ₂ SO ₄	- .02	6×10^{-6}	- .72	1×10^{-4}
CrO ₃	+ .3	2×10^{-6}	+ .8	2×10^{-6}

Table IV and Table V compare the three passivators studied and their effects on potential and current at approximately 1 M concentration.

The three passivators studied in non-aqueous solutions showed similar characteristics with respect to each other as they did in aqueous solutions. Sulfuric acid was unable to passivate iron in aqueous solution without the external application of an EMF. Nitric acid passivated in aqueous solution but at a very high concentration. Chromium trioxide was an effective passivator in aqueous solutions at a low concentration compared to nitric acid. The order of passivating effectiveness in aqueous solution was

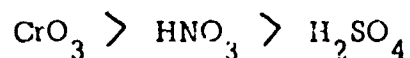

In aqueous solution the presence of the sulfate ion had a deleterious effect on the passivating ability of other passivators. By catalyzing the acetic acid- acetic anhydride solution with trifluoroacetic

acid, the presence of the sulfate moiety was eliminated. This had a considerable effect on the platinum electrode potential, raising it from $-.06$ to $+0.3$ volts, in the solvent, but had little effect on the passivation potential exhibited in the solutions of HNO_3 and CrO_3 .

Data from Table III shows that sulfuric acid raised the potential of iron with respect to hydrogen from $-.76$ volts in the solution containing only catalytic amounts of sulfuric acid to $-.80$ volts in the solution containing $.05$ moles of sulfuric acid. In causing this potential increase, the H-Pt potential actually dropped from $-.06$ volts to $-.01$ volts. This rise in the potential of the iron electrode was compared to a drop in potential for the nitric acid solution of H-Fe from $-.76$ volts to $-.28$ volts, and in the CrO_3 solution, from $-.76$ volts to $+0.9$ volts.

Table IV and Table V show that the H-Fe potential in the solvent catalyzed by sulfuric acid was $-.76$ volts as compared to $-.06$ volts for the trifluoroacetic acid catalyzed solution. The same comparative results are noted with respect to the passivation effectiveness of the acids in this solution. The sulfuric acid catalyst had no marked effect on the value of the potential (versus hydrogen) in the passivating systems, but the relative potential drop in the chromium trioxide system was only about $.9$ volts compared to almost 1.7 volts in the sulfuric acid catalyzed solution. This indicates that the potential drop is about $.9$ volts and that the potential rise, caused by catalytic

Fig - 9

Relative Effectiveness of Passivators in Non-Aqueous Solution
 (Each solution contains 40ml acetic acid, 10 ml acetic anhydride, 2ml
 trifluoroacetic acid catalyst plus reagent indicated)

Solvent 0.05moles H_2SO_4 0.05moles HNO_3 0.05 moles CrO_3

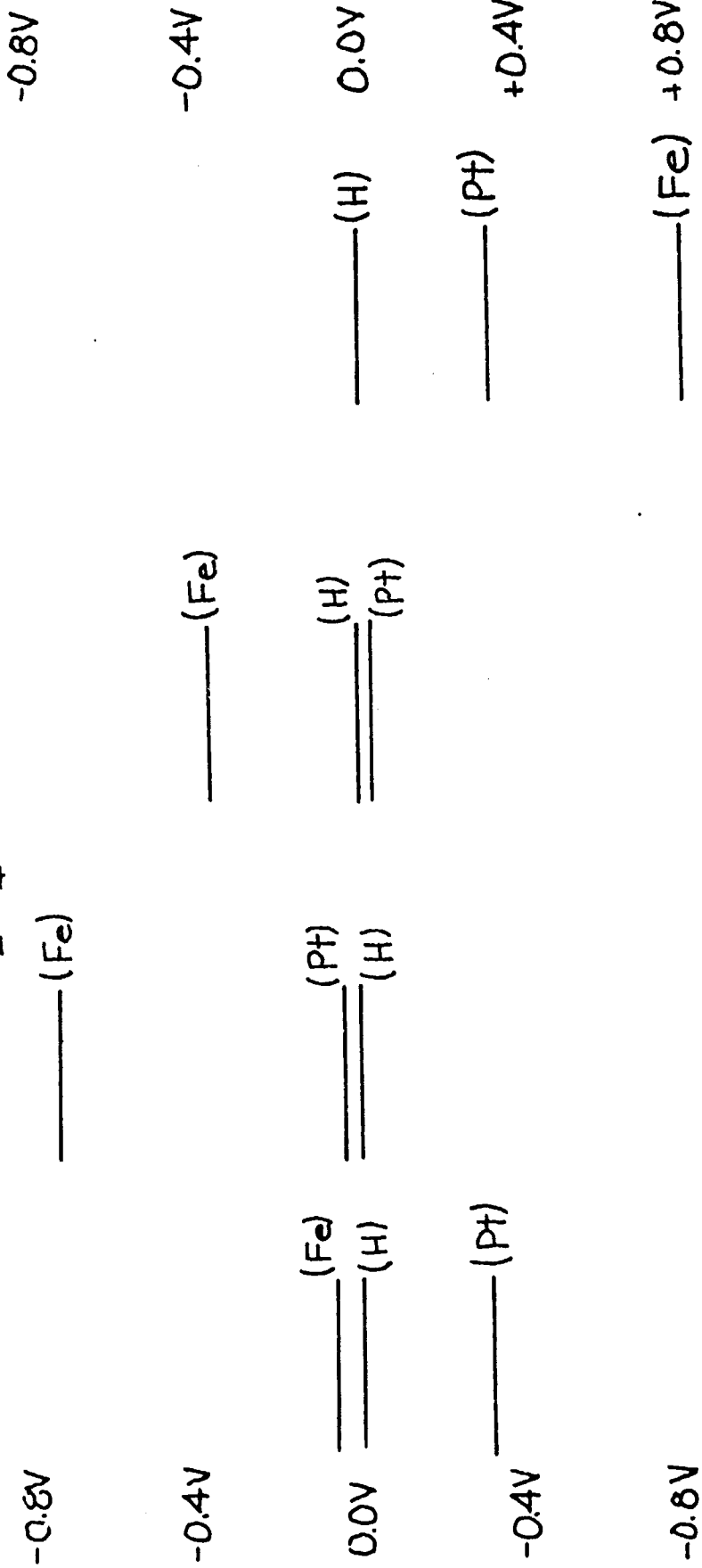
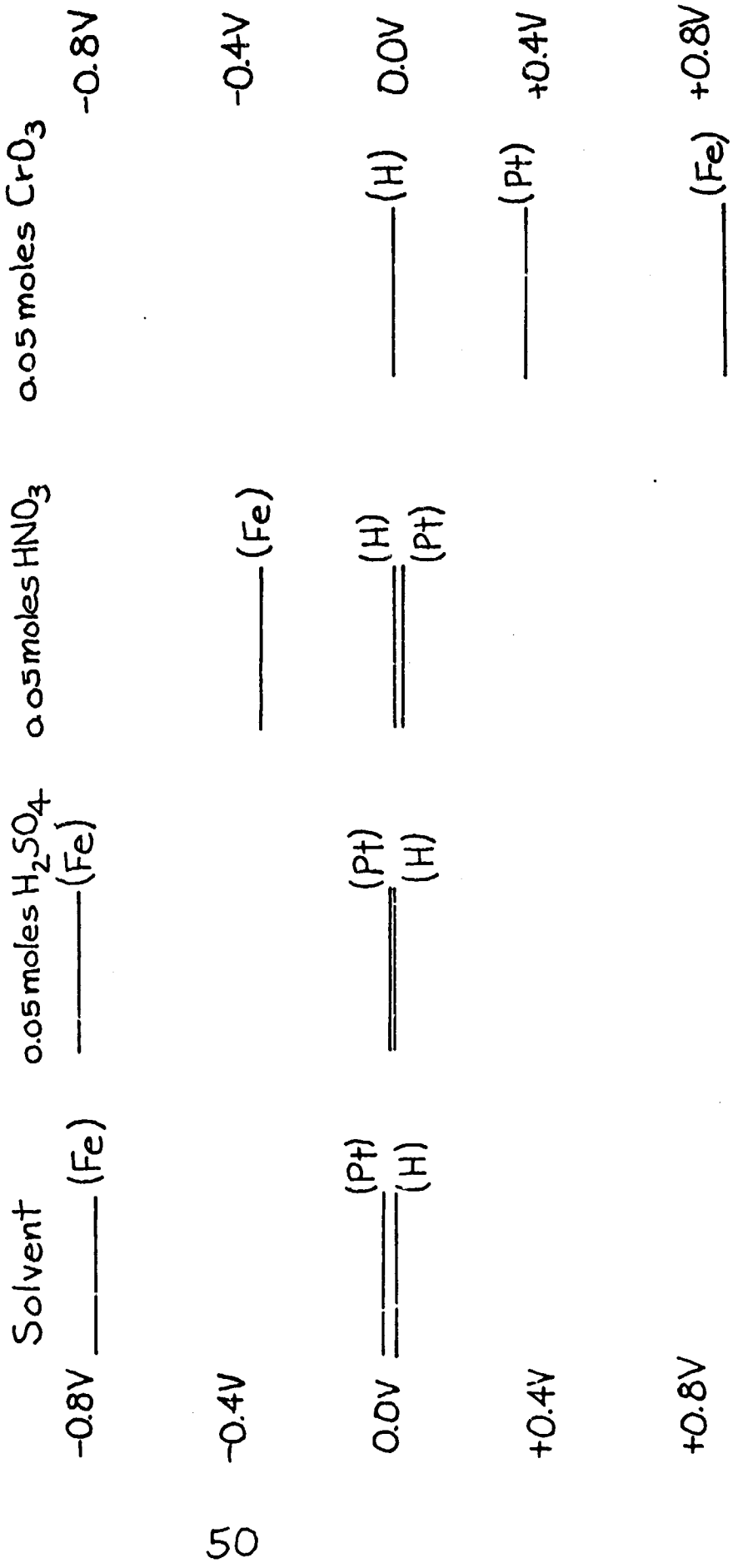

Fig - 10

Relative Effectiveness of Passivators in Non-Aqueous Solution
 (Each solution contains 40 ml acetic acid, 10 ml acetic anhydride, 2 drops
 sulfuric acid catalyst plus reagent indicated)



amounts of sulfuric acid, is completely overshadowed by the presence of .02 moles of the acid passivator.

A convenient way of representing the relative passivation tendencies of the acids considered is shown in Figure 9 and Figure 10.

VI. CONCLUSIONS

Passivity of iron has been produced in the non-aqueous solvent acetic acid-acetic anhydride using three common passivating agents -- nitric acid, sulfuric acid, and chromium trioxide. Non-aqueous passivity has been characterized by voltage measurements with respect to the hydrogen electrode, and found to be similar to aqueous passivity in nitric acid as reported in Table I and Table II.

Passivity in this medium eliminates water-solvated ionic interactions and water-solution stabilization as suggested by Okamoto [Ref. 21] as essential processes in the production of a passive film. The passivating species in the anhydrous medium are not the anions produced in aqueous solution. The passivation potentials and relative passivation effectiveness of the passivating species ($\text{CrO}_3 > \text{NO}_3 > \text{SO}_4$) are similar to that observed in aqueous solution. An effect, peculiar to the properties of the iron in conjunction with solution species, must result in passivity. The passivating agents used in aqueous and non-aqueous solutions are the same, but this similarity ends when the passivator is added to the solution. The existence of free nitrate, sulfate, and chromate ions, as in aqueous solution, can be ruled out. This immediately brings the specific molecular models of Cartledge and Evans into question as explanations for the mechanism of passivity in non-aqueous solution. If we assume that passivity is the same in both aqueous and non-aqueous solution, we must take a step

back from the metal-passivator interactions described by Cartledge and Evans and instead look either to the thermodynamic properties of the species or perhaps to the passivated metal itself. It has been suggested [Ref. 29] that passivity may be the result of a bonding change of surface metal atoms, i.e., from body-centered cubic to face-centered cubic.

If the adsorption model proposed by Uhlig [Ref. 24] represents passivity in aqueous and non-aqueous solution, it is indeed fortuitous that the adsorption phenomena exhibited by different species in different solutions should show such similar voltage effects.

The composition of the film as presented by Cohen, et. al., [Ref. 8] requires the formation of water in the passivation process which takes place in the non-aqueous medium. Bloom and Goldenberg [Ref. 23] have proposed that the reaction of $\alpha\text{-Fe}_2\text{O}_3$ with hydrogen leads to the formation of $\gamma\text{-Fe}_2\text{O}_3$ through the production of water and Fe_3O_4 ; and then, subsequent reaction of the water with $\alpha\text{-Fe}_2\text{O}_3$ to produce $\gamma\text{-Fe}_2\text{O}_3$ with the formula HFe_5O_8 . Oxidation of the iron to $\gamma\text{-Fe}_2\text{O}_3$ in the non-aqueous medium with the by-product water could provide a mechanism for film formation using Bloom and Goldenberg's proposal. The question then arises -- what about the "inner" film of Fe_3O_4 ? Overall, the composition and structure of the passive film in aqueous solution cannot be easily assumed to be the same as in the non-aqueous solution. Yet the passivation voltages in both systems are remarkably similar. If, as before, we assume that the same

essential change has caused passivity in both cases, the conclusion is that the oxide film is an effect and not the cause of passivity. Of course structural studies of specimens passivated in non-aqueous solution are needed to reveal the actual surface state of the iron.

Also in question at this point is the necessity of the observed bound water in the film. Okamoto [Ref. 22] showed the presence of bound water, but an interesting observation was not interpreted. The amount of bound water was less in a sample passivated for 1000 minutes than in a similar sample passivated for 60 minutes. This may be explained in two ways:

- 1) The amount of bound water decreases through a slow reaction to form more film, or
- 2) The bound water is not necessary in the passive film, but is initially trapped in the film lattice and gradually escapes into solution.

Results obtained by Frankenthal [Ref. 3] from cathodic chronopotentiometry show that film thickness is independent of the time of passivation. No other references cited observe a continuous slow growth in thickness of the passive film that would lend support to the first explanation.

The actual presence of bound water in the passive film produced in non-aqueous media has not been determined. The microthermogravimetric techniques of Okamoto [Ref. 21] may be used to resolve this question.

The phenomenological models of Bockris [Ref. 17] and Frankenthal [Refs. 3, 4, and 5] showing differing film conductivities seem to explain passivity as intimately as possible with present knowledge. Specific interactions of solution species, necessary to a complete understanding of passivity, are not presented or resolved. Available information on passivity consists of a large body of accurate measurements of the effects accompanying the passivation process. No unambiguous model is available to explain the actual mechanism that causes the observed effects.

In summary, passivity in the non-aqueous solution of acetic acid-acetic anhydride has been observed and characterized by voltage measurements. These measurements show a striking similarity to those in aqueous solution. This suggests that the same basic process is involved in both cases. Sulfuric acid, nitric acid, and chromium trioxide were used as passivating agents in the non-aqueous medium and their order is the same as in aqueous solution. The difference in the actual species in solution raises the question of the applicability of several of the passivity models outlined. Finally, suggestions have been made for experimentation to clarify the passivation process using non-aqueous passivated specimens.

APPENDIX A

Experimental Characterization of Aqueous Passivity

In beginning the study of passivity it was useful to characterize the phenomenon by simple laboratory experiments. Using the common medium of nitric acid solution, passivity may be readily observed by first immersing an iron sample in concentrated nitric acid, and then quickly transferring it to a corrosive dilute nitric acid solution. The iron remains bright without visible corrosion, and is in its passive state.

Direct immersion of a freshly-prepared clean iron surface in 1 N to 8 N nitric acid shows immediate corrosion, accompanied by the rapid evolution of large quantities of nitrous oxide and nitrogen dioxide, near the upper end of this concentration range. In concentrations of 9 N to 10 N, a peculiar passive-active alternation is observed on the iron surface. At these concentrations there is nearly an equal tendency for corrosion and passivation. Initially, corrosion begins above the water line. Evolution of gas can be observed to proceed downward until gas is evolved over the entire surface. At this point the corrosion ceases and the metal is again bright and passive. After a certain length of time, which becomes increasingly shorter with each cycle, corrosion begins again. This cycle continues until corrosion takes over permanently when the solution has become sufficiently reduced by iron oxidation during the active portion of the cycle.

Molecular oxygen has a pronounced effect on the passivation process in the cases of several anions normally referred to as passivators. The presence of oxygen is necessary for the passivation process of organic inhibitors such as phthalates and benzoates. Experiments showing the percentage of cathodic current supplied by oxygen for several inorganic passivators were performed by Cartledge [Refs. 30, 15, and 16]. For example, Cartledge showed that deoxygenated chromate ion solution raised the potential toward passivity but to a much lesser extent than in the presence of oxygen. Reduction of the chromate ion was found to produce only 1% to 5% of the cathodic current at the passivation potential. Osmium (VIII) oxide reduction, on the other hand, produced almost all of the cathodic current.

Noting the importance of oxygen in passivity and its paramagnetic property, along with the fact that metals upon which passivity may be produced are transition metals which tend to have magnetic properties, it was thought that a magnetic effect might be important in passivity. If passivity were caused by weakly chemisorbed oxygen, then a moving magnetic field on iron that had been rendered insipiently active by concentration or potential means may provide the activation energy necessary to convert iron to the active state. Experiments with a bar magnet at different concentrations and potentials showed the magnetic field to have no effect on the breakdown or potential of passivation.

It is important to note that corrosion in general, and the breakdown of passivity in particular, requires two paths. An ionic path

through the solution, and an electronic path through metallic contact are both required. Experiments eliminating either of these paths have no effect on the breakdown of passivity. It was found that corrosion products of an active iron specimen in contact with passive iron in the same solution had no deleterious effect on the passive state, while physical contact between the two specimens always renders both active. The ionic path was eliminated by electrical contact between active and passive specimens in separate breakers. Again passivity was retained.

APPENDIX B

Observation of Iron in Dioxane and Tetrahydrofuran Solutions of Fuming Nitric Acid

The solvent 1, 4 dioxane was chosen because of its relatively high polarity. The dioxane was purified and dehydrated by distillation with sodium hydroxide pellets into lithium hydride and redistilled to the final product [Ref. 25]. Anhydrous nitric acid was prepared by the addition of sulfuric acid to sodium nitrate, then distilled into a desiccant-protected glass receptacle.

Direct mixture of nitric acid and dioxane proved to be too exothermic to achieve the ratio required for passivity. Furthermore, after mixing relatively small amounts of the two reagents, the mixture was proven to explode on standing.

Observations of the dioxane system were:

1) Lithium nitrate was used as the analog of nitric acid to produce the nitrate ion as a passivator. Corrosion of the type observed in .5 N aqueous nitric acid was noted, but the salt was not soluble enough to reach passivating concentrations.

2) No corrosion was observed in "dilute" dioxane-nitric acid solution. Quick transferral of the specimen to a dilute nitric acid solution showed maintenance of this non-corrosive state. Electrode preparation by etching in dilute nitric acid, rinsing with water and air drying led to a water-formed surface oxide film and inconclusive results.

3) The same effects as noted in 2) were found using the highest ratio of nitric acid-dioxane obtained. Attempts to increase the concentration by the addition of lithium nitrate had no effect on the state of the iron.

4) Upon the addition of water in the amount of one-third the solution volume, the corrosion-passivation cycle previously described was evident.

5) Solubility tests of ferric nitrate and ferric oxide, likely corrosion products, showed an approximate equivalence in solubility in water and dioxane.

Observations of the tetrahydrofuran system were:

1) The solubilities of ferric nitrate and ferric oxide in purified dehydrated tetrahydrofuran were approximately equivalent to those in water.

2) Observable corrosion was noted in mixtures of nitric acid (fuming) and tetrahydrofuran, but again the mixture became explosive before becoming passivating.

BIBLIOGRAPHY

1. Uhlig, H.H., Corrosion and Corrosion Control, p. 57, Wiley, 1965.
2. Wagner, C., Discussions at First International Symposium on Passivity, Heiligenberg, West Germany, 1957.
3. Frankenthal, R.P., "On the Passivity of Iron-Chromium Alloys, Part I: Reversible Primary Passivation and Secondary Film Formation," Journal of the Electrochemical Society, v. 114, p. 542-547, June 1967.
4. Frankenthal, R.P., "On the Passivity of Iron-Chromium Alloys, Part II: The Activation Potential," Journal of the Electrochemical Society, v. 116, p. 580-585, May 1969.
5. Frankenthal, R.P., "On the Passivity of Iron-Chromium Alloys, Part III: Effect of Potential," Journal of the Electrochemical Society, v. 116, p. 1646-1651, December 1969.
6. Evans, U. R., The Corrosion and Oxidation of Metals, p. 1042-1047, St. Martin's Press, Inc., 1960.
7. Sympson, R.R. and Cartledge, G.H., "The Mechanism of the Inhibition of Corrosion by the Pertechnetate Ion, Part IV: Comparison with Other XO_4^{-n} Inhibitors," Journal of Physical Chemistry, v. 60, p. 1037-1043, August 1956.
8. Nagayama, M. and Cohen M., "The Anodic Oxidation of Iron in a Neutral Solution, Part I: The Nature and Composition of the Passive Film," Journal of the Electrochemical Society, v. 109, p. 781-790, September 1962.
9. Sato, S. and Cohen, M., "The Kinetics of Anodic Oxidation of Iron in Neutral Solution, Part I: Steady Growth Region," Journal of the Electrochemical Society, v. 111, p. 512-519, May 1964.
10. Sato, N. and Cohen, M., "The Kinetics of Anodic Oxidation of Iron in Neutral Solution, Part II: Initial Stages," Journal of the Electrochemical Society, v. 111, p. 519-522, May 1964.
11. Cartledge, G.H., "The Mechanism of the Inhibition of Corrosion by the Pertechnetate Ion, Part I: The Origin and Nature of Reaction Products," Journal of Physical Chemistry, v. 59, p. 979-984, September 1955.

12. Cartledge, G.H., "The Comparative Roles of Oxygen and Inhibitors in the Passivation of Iron, Part IV: Osmium (VIII) Oxide," Journal of Physical Chemistry, v. 65, p. 1361-1367, August 1961.
13. Cartledge, G.H., "The Mechanism of the Inhibition of Corrosion by the Pertechnetate Ion, Part II: The Reversibility of the Inhibiting Mechanism," Journal of Physical Chemistry, v. 60, p. 28-32, January 1956.
14. Cartledge, G.H., "The Mechanism of the Inhibition of Corrosion by the Pertechnetate Ion, Part III: Studies on the Perrhenate Ion," Journal of Physical Chemistry, v. 60, p. 35, January 1956.
15. Cartledge, G.H., "The Comparative Roles of Oxygen and Inhibitors in the Passivation of Iron, Part II: The Pertechnetate Ion," Journal of Physical Chemistry, v. 64, p. 1882-1887, December 1960.
16. Cartledge, G.H., "The Comparative Roles of Oxygen and Inhibitors in the Passivation of Iron, Part III: The Chromate Ion," Journal of Physical Chemistry, v. 65, p. 1009-1015, June 1961.
17. Bockris, J. O'M., Reddy, A.K.N., and Rao, B., "An Ellipsometric Determination of the Mechanism of Passivity of Nickel," Journal of the Electrochemical Society, v. 113, p. 1133-1144, November 1966.
18. Spitsin, V.I., and others, "Investigation of Inhibiting Properties of the Pertechnetate Ion," Corrosion, v. 21, p. 211-221, July 1965.
19. Frankenthal, R.P., "On the Passivity of Iron-Chromium Alloys, Part I: Reversible Primary Passivation and Secondary Film Formation," Journal of the Electrochemical Society, v. 114, p. 543, June 1967.
20. Rhodin, T.N., Annual of the New York Academy of Science, v. 58, p. 855, 1954.
21. Okamoto, G., and others, "The Existence of Bound Water in the Passive Films Formed on Stainless Steels," Extended Abstracts of the Congress of Metallic Corrosion, New York, v. 50, p. 558-562, 1963.

22. Okamoto, G., and Shibata, T., "Desorption of Tritiated Bound-Water from the Passive Film Formed on Stainless Steels," *Nature*, v. 206, p. 1350, 26 June 1965.
23. Bloom, M., and Goldenberg, L., " Fe_2O_3 and the Passivity of Iron," *Corrosion Science*, v. 2, p. 623-630, 1965.
24. Yolken, H.T., Kruger, J., and Calvert, J.P., "Hydrogen in Passive Films on Fe," *Corrosion Science*, v. 8, p. 103-108, 1968.
25. Rowell, C., private communication, May 1969
26. Fieser, L.F., and Fieser, M., *Reagents for Organic Synthesis*, p. 1117, Wiley, 1967.
27. Fieser, L.F., "Naphthoquinone Antimalarials, Part XVII: Chromic Anhydride Oxidation," *Journal of the American Chemical Society*, v. 70, p. 3237, 1948.
28. Hoover, T.B., and Hutchison, A.W., "Estimation of Water in Fuming Nitric Acid," *Analytical Chemistry*, v. 29, p. 518-522, April 1957.
29. Helliwell, R.W., private communication, May 1969.
30. Cartledge, G.H., "The Comparative Roles of Oxygen and Inhibitors in the Passivation of Iron, Part I: Non-Oxidizing Inhibitors," *Journal of Physical Chemistry*, v. 64, p. 1877-1882, December 1960.

DOCUMENT CONTROL DATA - R & D

(Security classification of title, body of abstract and indexing annotation must be entered when the overall report is classified)

1. ORIGINATING ACTIVITY (Corporate author) Naval Postgraduate School Monterey, California 93940		2a. REPORT SECURITY CLASSIFICATION Unclassified	
		2b. GROUP	
3. REPORT TITLE A Study of Passivity of Iron in Non-Aqueous Solution			
4. DESCRIPTIVE NOTES (Type of report and, inclusive dates) Master's Thesis June 1970			
5. AUTHOR(S) (First name, middle initial, last name) Stephen Marks Burkhalter			
3. REPORT DATE June 1970		7a. TOTAL NO. OF PAGES 65	7b. NO. OF REFS 30
8a. CONTRACT OR GRANT NO.		9a. ORIGINATOR'S REPORT NUMBER(S)	
b. PROJECT NO.			
c.		9b. OTHER REPORT NO(S) (Any other numbers that may be assigned this report)	
d.			
10. DISTRIBUTION STATEMENT This document has been approved for public release and sale; its distribution is unlimited.			
11. SUPPLEMENTARY NOTES		12. SPONSORING MILITARY ACTIVITY Naval Postgraduate School Monterey, California 93940	
13. ABSTRACT Passivity in aqueous solutions is reviewed and several proposed passivity models are outlined. Passivity in the <u>non-aqueous</u> solution of acetic acid-acetic anhydride was observed and characterized by voltage measurements. These measurements show a striking similarity to those in aqueous solution. This suggests that the same basic process is involved in both cases. Sulfuric acid, nitric acid, and chromium trioxide were used as passivating agents in the non-aqueous medium and their order is the same as in aqueous solution. The difference in the actual species in solution raises the question of the applicability of several of the passivity models outlined. Finally, suggestions are made for experiments to clarify the passivation process using non-aqueous passivated specimens.			

14 KEY WORDS	LINK A		LINK B		LINK C	
	ROLE	WT	ROLE	WT	ROLE	WT
Non-Aqueous Passivity Acetic Acid-Acetic Anhydride Solution						