

**Best
Available
Copy**

RECEIVED
FEB 11 1971

AD 71 2785

The Acute Hyperbaric Toxicity of Carbon Monoxide¹

C. S. ROSE, R. A. JONES, L. J. JENKINS, JR., AND J. SIEGLI

*U. S. Navy Toxicology Unit, National Naval Medical Center,
Bethesda, Maryland 20014*

Received January 26, 1970

The Acute Hyperbaric Toxicity of Carbon Monoxide. ROSE, C. S., JONES, R. A., JENKINS, L. J., JR., and SIEGLI, J. (1970). *Toxicol. Appl. Pharmacol.* 17, 752-760. The effects of elevated pressures (25, 50, 75, and 100 psig) on the toxicity of carbon monoxide (CO) in guinea pigs, rats, and mice were examined in a series of 4-hr exposures. The partial pressure of oxygen (pO₂) was maintained between 140 and 160 mm Hg during all exposures. The LC50 values (lethal concentration of carbon monoxide for 50% of the animals exposed) expressed in milligrams per cubic meter of CO, were not appreciably altered by increases in pressure within the range studied. At death, the blood carboxyhemoglobin concentrations showed very little variation regardless of the exposure pressure.

In recent years, much interest has been generated in manned exploration under the sea, and with this has come the need to develop data concerning the toxicity of atmospheric contaminants under hyperbaric conditions.

A wealth of information has been accumulated regarding the effect of carbon monoxide (CO) on living systems at normal atmospheric pressure. This information has been summarized in reviews by Drinker (1938), von Oettingen (1944), Lilienthal (1950), and in the bibliography with abstracts compiled by Cooper (1966). More recently, Bartlett (1968) and Goldsmith and Landaw (1968) reported on the pathophysiology and on the general effects on the health of humans following exposure to low concentrations of CO.

In vivo and *in vitro* studies on CO have been conducted at hypo- and hyperbaric conditions by Back and Dominguez², Berger *et al.* (1964), and Rodkey *et al.* (1969). A search of the literature, however, failed to produce information pertaining to the acute toxicity of carbon monoxide in intact animals under hyperbaric conditions.

The hyperbaric toxicity of oxygen is well recognized and has been taken into consideration in establishing safe procedures during its use at elevated pressures (U.S. Navy, 1963). Since no untoward effects are noted when the partial pressure of oxygen is maintained at approximately 160 mm Hg regardless of the overall pressure of the

¹ The opinions expressed herein are those of the authors and do not necessarily reflect the views of the Navy Department or the naval service at large. The experiments reported herein were conducted according to the principles enunciated in "Guide for Laboratory Animal Facilities and Care" prepared by the Committee on the Guide for Laboratory Animal Resources, National Academy of Sciences-National Research Council, Washington, D. C.

² BACK, K. C., and DOMINGUEZ, A. M. (1968). Psychopharmacology of carbon monoxide under ambient and altitude conditions. Aerospace Medical Research Laboratories Report AMRL-TR-68-175, pp. 81-92, Dec. 1968.

9

system, it was reasoned that the toxicity of carbon monoxide should also depend solely on the number of molecules presented to the alveoli, if the partial pressure of oxygen remained constant. The following studies were conducted to evaluate this hypothesis.

METHODS

Experimental animals. The animals utilized in these studies consisted of male NMRI:O(SD) Sprague-Dawley-derived rats (225-300 g), male NIH NmrI Swiss albino mice (23-30 g), and male FTD: Hartley guinea pigs (300-450 g). Prior to exposure, the animals were maintained on the appropriate food and water ad libitum.

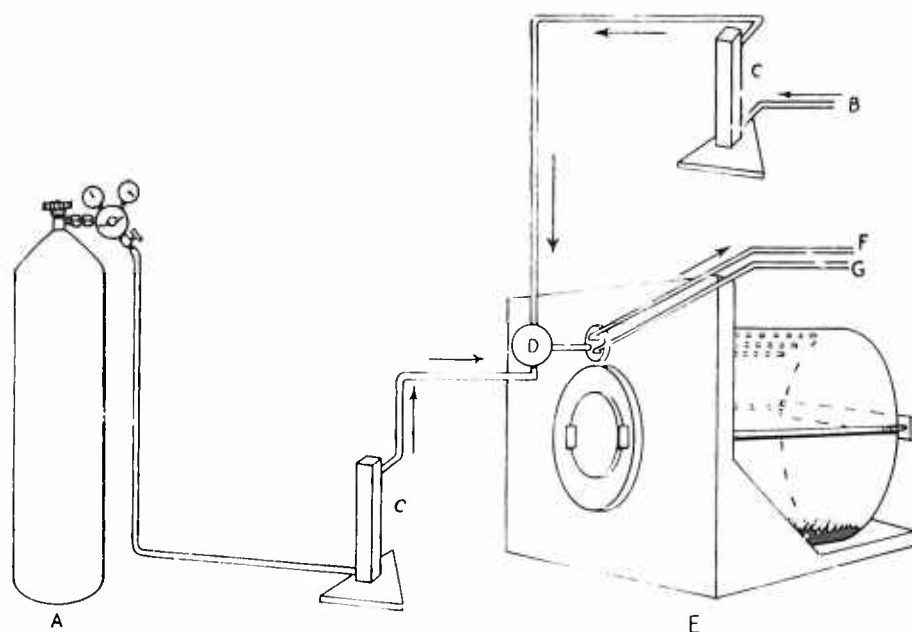

FIG. 1. Schema of exposure system used at 0 psig. A, carbon monoxide cylinder (C. P. Grade) and regulator; B, house air for dilution; C, flowmeters; D, mixing flask; E, exposure chamber; F, exhaust line; G, sampling line.

Exposure equipment and materials. Exposures at normal atmospheric pressure (0 psig) were conducted in a 30-l chamber essentially as described by Leach (1963). A predetermined amount of carbon monoxide (C. P. grade¹) was mixed with 7.1 l per minute of laboratory air and introduced into the chamber. The system used is shown schematically in Fig. 1.

The hyperbaric studies were conducted in an 8.6-l chamber² rated for a maximum pressure of 150 psig at 70 F. For these exposures, certified premixed cylinders of carbon monoxide, oxygen, and helium were procured.³ Additional intermediate concentrations were mixed, as required, from the primary cylinders. During all runs, the partial pressure of oxygen was maintained between 140 and 160 mm of Hg by decreasing the oxygen from 21% (0 psig) to 7.6% (25 psig), 4.6% (50 psig), 3.3% (75 psig), and 2.6% (100 psig).

¹ Carbon monoxide and certified gas mixtures were obtained from Air Products and Chemicals, Inc., Allentown, Pennsylvania.

² Bethlehem Chamber Model 614. The Bethlehem Corporation, Bethlehem, Pennsylvania.

In a similar manner, the various concentrations of carbon monoxide in the gas mixtures introduced into the chamber for the LC50 determinations had to be lowered concomitantly with the stepwise increases in pressure.

The pressure in the chamber was continuously monitored using a top-mounted pressure gauge with a range of 0-100 psig. During exposures, chamber pressures were maintained within ± 0.5 psig of the desired pressures. The gaseous mixtures containing carbon monoxide were dynamically fed into the chamber through $\frac{1}{4}$ -inch flexible tubing and an exhaust flow rate of 4-5 l per minute was maintained during the exposure period. After all exposures, the chamber was decompressed with a mixture of 79% helium and 21% oxygen at a predetermined uniform rate depending on the experimental pressure. Rapid decompression was not used since at times one or more animals would not be visible

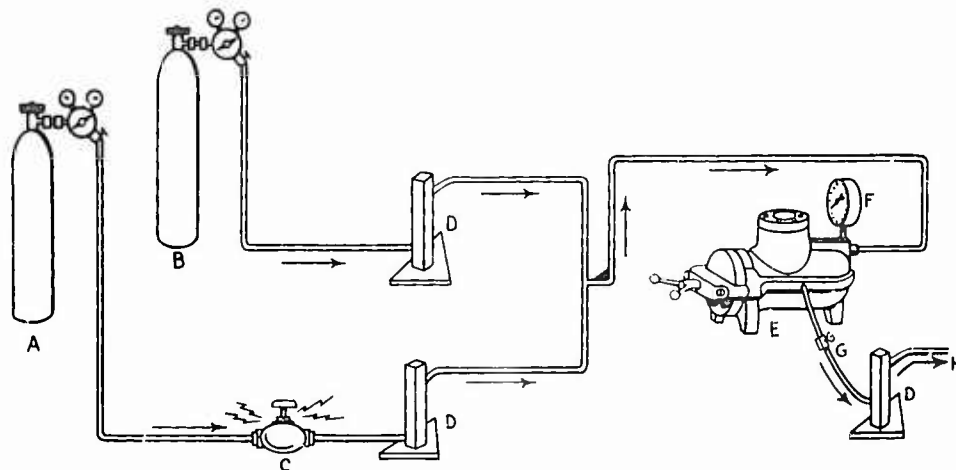

FIG. 2. Schema for hyperbaric exposures at 25, 50, 75, and 100 psig. *A*, cylinder containing decompression mixture of 79% helium, 21% oxygen with regulator; *B*, cylinder containing mixtures of carbon monoxide, oxygen, and helium with regulator; *C*, motorized valve; *D*, flowmeters; *E*, hyperbaric chamber; *F*, pressure gauge; *G*, exhaust flow regulator valve; *H*, exhaust line.

through the chamber window at the termination of an exposure and an accurate death count would not have been obtained. The system used is presented diagrammatically in Fig. 2. The thermal variation of the chamber atmosphere as measured by a thermocouple, did not exceed ± 2 C of room temperature (23 C) during the animal exposure and decompression phases.

In both the 0 psig and hyperbaric studies, chamber loadings consisted of 4 rats, 4 guinea pigs, or 16 mice and all exposures were of 4-hr duration. The 4-hr exposure period was arbitrarily selected because of its general use in this and other laboratories in acute LC50 studies with other materials at normal atmospheric pressure. The parameters examined were the LC50 values and the carboxyhemoglobin saturation levels in animals that died during the exposure.

Immediately after the exposures at 0 psig or the decompression phase after the hyperbaric runs, cardiac blood samples were collected from the dead rats and guinea pigs and analyzed for carboxyhemoglobin concentration. The surviving animals were not observed further and were sacrificed.

Analytical techniques. In all exposures at normal atmospheric pressure, the actual concentration of CO was continuously monitored throughout the 4-hr period by a double-beam infrared spectrophotometer⁵ set at a wavelength of 2160 cm^{-1} and using a 5.65 l variable-pathlength gas cell. All laboratory mixed cylinders for the hyperbaric exposures were analyzed for carbon monoxide concentration by the infrared spectrophotometer or a gas chromatograph⁶; no monitoring during the run was considered necessary. The gas chromatograph was equipped with a 6 ft \times $\frac{1}{8}$ in. o.d. stainless steel column packed with 60-80 mesh molecular sieve 5A maintained at 100 C. A nickel oxide catalyst, prepared according to Porter and Volman (1962), reduced the CO to methane, which was quantitated using a flame ionization detector; the detector and catalyst were maintained at 300 C.

Carboxyhemoglobin method. Blood carboxyhemoglobin concentration was determined by a method based on the work of Stowe and Pelletier (1968) using a two-channel automatic chemical analyzer.⁷ A specimen of blood, with ethylenediaminetetraacetic acid as the anticoagulant, was split into two streams. Total hemoglobin was determined in one stream as cyanmethemoglobin at 550 nm, and the carbon monoxide was released from hemoglobin in the other stream with 10% H_2SO_4 . The gas phase was then removed with a trap and reacted with the silver salt of *p*-sulfaminobenzoic acid in alkaline solution. This resulted in a colloidal solution of silver which was measured spectrophotometrically at 420 nm (Ciuhandu, 1957). In order to standardize the above procedure, solutions of known concentrations of hemoglobin and carbon monoxide were prepared according to the method of Collison *et al.* (1968). Analyses indicated that at our range of concentrations the method had a relative error of approximately 8% and a relative standard deviation of 9%.

RESULTS

In general, all animals lost consciousness during the first 1-2 hr of exposure to carbon monoxide. The mortality in rats, mice, and guinea pigs exposed to various concentrations of CO at 0, 25, 50, 75, and 100 psig is shown in Table 1. Only those deaths which occurred during the actual 4-hr exposure period were included in the table. One guinea pig died during decompression following termination of an 8228 mg m^{-3} exposure at 50 psig.

The LC50 values, expressed in milligrams per cubic meter (mg m^{-3}), and their 95% confidence limits are summarized in Table 2; these were calculated by the method of Litchfield and Wilcoxon (1949) and are depicted in Fig. 3. As can be seen, the LC50 for rats, guinea pigs, and mice remained in the same range when the pressure was increased from 0 to 100 psig; the variations noted were not considered to be biologically significant. Guinea pigs were less susceptible to CO intoxication at all pressures than were the rats and mice.

The values for percent blood hemoglobin (% COHb) saturation with carbon monoxide for rats and guinea pigs at death at each of the exposure levels and pressures are presented in Table 1; no significant biological differences were noted which reflected

⁵ Model 21 Spectrophotometer, Perkin-Elmer Corporation, Norwalk, Connecticut.

⁶ Model 150 Gas chromatograph, Micro-Tek Division, Tracor Analytical Instruments, Austin, Texas.

⁷ Auto-Analyzer, Technicon Corporation, Ardsley, New York.

TABLE 1
MORTALITY AND CARBOXYHEMOGLOBIN VALUES IN ANIMALS EXPOSED TO SELECTED CONCENTRATIONS OF CARBON MONOXIDE
FROM 0 TO 100 PSIG

psig	Rats			Guinea Pigs			Mice		
	Concentration ppm	Mortality dead total	COHb ^a (%)	Concentration ppm	Mortality dead total	COHb ^a (%)	Concentration ppm	Mortality dead total	Concentration mg m ³
0	1600	14	47.5	4000	400	—	1985	2184	0.16
	1800	24	56.0	5040	5544	69.7	2230	2453	1.16
	2000	48	55.7	6350	6985	85.6	2355	2591	7.32
	2200	1112	59.4	7980	8778	74.2	2650	2915	14.16
25	620	18	56.4	1600	4752	—	3000	3300	15.16
	825	14	55.0	2100	5237	89.6	620	1841	1.17
	900	1316	52.2	2500	7425	56.5	900	2673	4.19
	1200	34	62.9	—	—	—	1050	3119	14.16
50	1600	88	79.5	—	—	—	1200	3564	16.16
	420	08	—	1000	4840	—	1250	3713	16.16
	490	18	64.4	1400	6776	64.9	330	1597	0.16
	520	58	60.0	1700	8228	62.2	400	1936	5.16
75	320	38	54.0	1800	8712	70.8	500	2420	10.16
	390	38	65.4	480	3221	—	650	5146	16.16
	425	28	50.5 ^c	780	5234	71.2	320	2147	2.16
	480	912	57.2	1100	7381	57.8	480	3221	23.32
100	550	88	60.9	1250	8388	72.9	550	3691	16.16
	280	28	61.5	500	4290	—	225	1931	0.16
	300	48	56.1	720	6178	57.2	250	2145	3.16
	318	78	70.8	880	7550	70.0	280	2402	14.16
			1000	8580	63.5	318	2728	16.16	

^a Dead animals only.

^b Carboxyhemoglobin values are given as the mean \pm 1 SD.

^c No specimen on 1 animal.

^d No specimen on 3 animals.

TABLE 2
CALCULATED CARBON MONOXIDE LC50 VALUES WITH PARTIAL PRESSURE GAS RATIOS AND RAT AND GUINEA PIG
CARBOXYHEMOGLOBIN PERCENTAGES^a

psig	Rats			Guinea pigs			Mice	
	CO LC50 (mg m ⁻³)	pCO pO ₂ for LC50	% COHb n Mean : SD	CO LC50 (mg m ⁻³)	pCO pO ₂ for LC50	% COHb n Mean : SD	CO LC50 (mg m ⁻³)	pCO pO ₂ for LC50
0	2070 (1831-2341) ^b	0.009	18 57.5 : 6.9	6550 (5509-7788)	0.029	14 77.6 : 10.4	2800 (2679-2926)	0.012
25	2670 (2278-3129)	0.012	26 62.1 : 15.8	6600 (5888-7399)	0.029	11 71.5 : 19.8	2700 (2457-2967)	0.012
50	2500 (2372-2635)	0.011	6 60.7 : 5.7	8300 (7339-9387)	0.036	14 67.5 : 16.1	2230 (2046-2431)	0.010
75	2680 (2354-3060)	0.012	24 58.8 : 8.7	7000 (5902-8302)	0.031	15 67.6 : 12.9	2800 (2528-3101)	0.012
100	2500 (2385-2620)	0.012	13 64.9 : 9.8	7900 (6834-9132)	0.036	9 65.0 : 8.3	2270 (2202-2340)	0.010

^a Values based on all concentrations of CO which resulted in animal deaths at a particular pressure.
^b 95% confidence limits.

any pressure or concentration changes. The mean values for COHb for each pressure (Table 2) exhibited little variation in the saturation levels producing death in rats and guinea pigs regardless of the exposure pressure. The mean percent saturation ranged from 57.5 to 64.9 for rats, and 65.0 to 77.6 for guinea pigs at the LC50 levels.

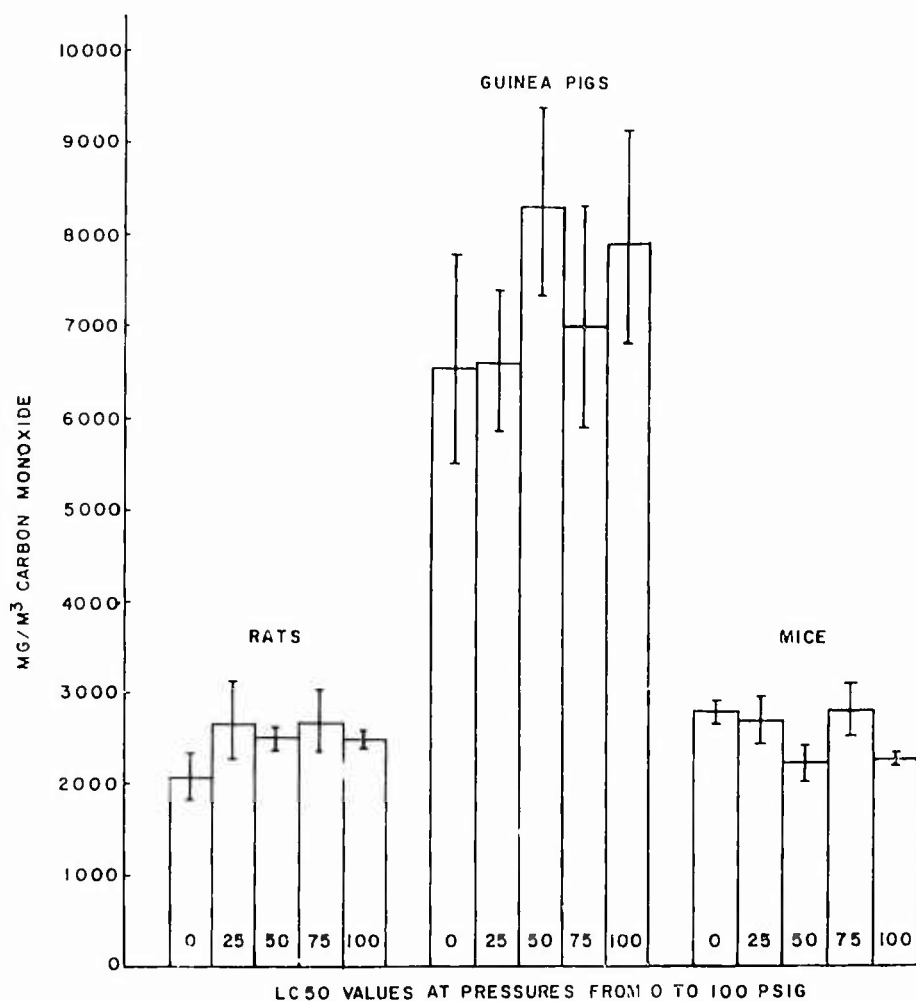

Fig. 3. LC50 of carbon monoxide in rats, guinea pigs, and mice at 0, 25, 50, 75, and 100 psig.

DISCUSSION

Contaminant concentrations at normal atmospheric pressure have been universally expressed in terms of parts per million (ppm) on a mass to volume basis, and in milligrams per cubic meter. At increased pressures, however, a distinct difference arises in the interpretation of ppm units. Concentration of the contaminant in a dynamic system in terms of mg m^{-3} increases by a factor directly proportional to the absolute pressure of the exposure system and reflects the number of molecules of the gas presented to the pulmonary alveoli of the animals. In contrast to this, the ppm value does not change with changes in pressure at a fixed concentration of CO. For example, in Table 1 the range of CO concentrations used to determine the LC50 values expressed in terms of ppm, decreased as the pressure was increased from 0 to 100 psig; this could lead to the

erroneous conclusion that CO is more toxic at increased pressures. This is not true when the absolute values for the amount of carbon monoxide are expressed in terms of mg m^{-3} . From the data obtained in this study it can be concluded that there is no alteration in the toxicity of CO in rats, guinea pigs, and mice as the pressure is increased from 0 to 100 psig.

It has been shown *in vitro*, with a carbon monoxide-air mixture, that the equilibrium percentage of blood carboxyhemoglobin produced by a given concentration of CO was independent of the environmental pressure (Berger *et al.*, 1964). Rodkey *et al.* (1969) demonstrated that the relative affinity constant of hemoglobin for carbon monoxide from both whole blood and prepared hemoglobin solutions was not significantly affected by elevated pressure or the inert gas component of the pressurized atmosphere. The carboxyhemoglobin levels and mean values obtained from intact animals at death in the present studies support these findings.

Henderson and Haggard (1943) indicated that at equilibrium the distribution of hemoglobin between carbon monoxide and oxygen depended on the ratio of the partial pressures of carbon monoxide to oxygen as well as the affinity of hemoglobin for these two components. Berger *et al.* (1964) suggested that the apparent toxicity of CO should be unaffected by elevated pressures if the ratios of these two gases remain constant. This was confirmed in the hyperbaric studies reported here, in which the pO_2 was maintained at 140 to 160 mm Hg and the ratios of the partial pressures of CO to O_2 were approximately the same at the LC50 for a particular species regardless of the total pressure of the exposure environment (Table 2).

In manned exploration under the sea, it is anticipated that many additional atmospheric contaminants other than CO will be encountered. Since carbon monoxide is unique in its mode of action, it is not possible to generalize from data on CO as to the toxicity of these other materials under hyperbaric conditions.

ACKNOWLEDGMENTS

The authors are indebted to Dr. A. F. Nieckarz, E. M. Swab, L. Kurlansik, J. P. Lyon, S. K. Sullivan and J. C. Zielinski for their assistance in various phases of the study. The constructive review and suggestions of R. C. Wands, Advisory Center on Toxicology, National Academy of Sciences—National Research Council is gratefully acknowledged.

REFERENCES

- BARILETTI, D., JR. (1968). Pathophysiology of exposure to low concentrations of carbon monoxide. *Arch. Environ. Health* **16**, 719-727.
- BERGER, L. B., CURRY, T. F., WATSON, H. A., and PEARCE, S. J. (1964). *Safe Use of Respiratory Protective Equipment in Work in Compressed Air: Detection and Physiological Effects of Gases Encountered*. U.S. Dept. of the Interior, Bureau of Mines, Report of Investigations 6540.
- CIUCHANDI, G. (1957). Photometrische Bestimmung von Kohlenmonoxyd in der Luft. *Z. Anal. Chem.* **155**, 321-327.
- COLLISON, H. A., RODKEY, F. L., and O'NEAL, J. D. (1968). Determination of carbon monoxide in blood by gas chromatography. *Clin. Chem.* **14**, 162-171.
- COOPER, A. G. (1966). *Carbon Monoxide. A Bibliography with Abstracts*. U.S. Dept. of Health, Education, and Welfare, Public Health Service Publication No. 1503. U.S. Government Printing Office, Washington, D. C.
- DUNKER, C. K. (1938). *Carbon Monoxide Asphyxia*, 276 pp. Oxford Univ. Press, London and New York.

- GOLDSMITH, J. R., and LANDAW, S. A. (1968). Carbon monoxide and human health. *Science* **162**, 1352-1359.
- HENDERSON, Y., and HAGGARD, H. W. (1943). *Noxious Gases and the Principles of Respiration Influencing Their Action*, 2nd ed., pp. 162-167. Reinhold, New York.
- LIACH, L. J. (1963). *A Laboratory Test Chamber for Studying Airborne Materials*. U. S. Atomic Energy Commission Research and Development Report UR 629, 1-12.
- LIJENTHAL, J. L., JR. (1950). Carbon monoxide. *Pharmacol. Rev.* **2**, 324-354.
- LITCHFIELD, J. T., JR., and WILCOXON, F. (1949). A simplified method of evaluating dose-effect experiments. *J. Pharmacol. Exp. Ther.* **96**, 99-113.
- PORTER, K., and VOLMAN, D. H. (1962). Flame ionization detection of carbon monoxide for gas chromatographic analysis. *Anal. Chem.* **34**, 748-749.
- RODKEY, F. L., O'NEAL, J. D., and COLLISON, H. A. (1969). Oxygen and carbon monoxide equilibria of human adult hemoglobin at atmospheric and elevated pressure. *Blood* **33**, 57-65.
- STOWE, H. W., and PELLETIER, M. F. (1968). *Automation in Analytical Chemistry, Technicon Symposia 1967*, Vol. 1, pp. 431-433, Mediad, White Plains, New York.
- U.S. Navy (1963). *U.S. Navy Diving Manual* NAVSHIPS 250-538. U.S. Government Printing Office, Washington, D. C.
- VON OETTINGEN, W. F. (1944). *Carbon Monoxide's Hazards and the Mechanism of Its Action*, U.S. Public Health Service, Public Health Bulletin No. 290. U.S. Government Printing Office, Washington, D. C.

