

ESD ACCESSION LIST

TRI Call No. 72635

ESD-TR-70-286

Copy No. 1 of 3 ~~CYL~~

DEPARTMENT OF DEFENSE

ELECTROMAGNETIC COMPATIBILITY ANALYSIS CENTER

AVIONICS INTERFERENCE PREDICTION MODEL (U)

Prepared by G. Morgan
of the IIT Research Institute

December 1970

ESD RECORD COPY

RETURN TO
SCIENTIFIC & TECHNICAL INFORMATION DIVISION
(TRI), Building 1210

DISTRIBUTION OF THIS DOCUMENT IS UNLIMITED.



AD0718997

ESD-TR-70-286

When U.S. Government drawings, specifications, or other data are used for any purpose other than a definitely related government procurement operation, the government thereby incurs no responsibility nor any obligation whatsoever; and the fact that the government may have formulated, furnished, or in any way supplied the said drawings, specifications, or other data is not to be regarded by implication or otherwise, or in any manner licensing the holder or any other person or corporation, or conveying any rights or permission to manufacture, use or sell any patented invention that may in any way be related thereto.

Do not return this copy. When not needed, destroy.

ESD-TR-70-286

AVIONICS INTERFERENCE PREDICTION MODEL

Technical Report

ESD-TR-70-286

December 1970

DEPARTMENT OF DEFENSE
Electromagnetic Compatibility Analysis Center

Prepared by G. Morgan
of the IIT Research Institute

DOD DISTRIBUTION STATEMENT

Distribution of this document is unlimited.

Published by
Electromagnetic Compatibility Analysis Center
North Severn
Annapolis, Maryland 21402

FOREWORD

The Electromagnetic Compatibility Analysis Center (ECAC) is a Department of Defense facility, established to provide advice and assistance on electromagnetic compatibility matters to the Secretary of Defense, the Joint Chiefs of Staff, the military departments and other DOD components. The Center, located at North Severn, Annapolis, Maryland 21402, is under executive control of the Director of Defense Research and Engineering and the Chairman, Joint Chiefs of Staff or their designees who jointly provide policy guidance, assign projects, and establish priorities. ECAC functions under the direction of the Secretary of the Air Force and the management and technical direction of the Center are provided by military and civil service personnel. The technical operations function is provided through an Air Force sponsored contract with the IIT Research Institute (IITRI).

This report was prepared for the Federal Aviation Administration in accordance with Task assignment 2 of Interagency Agreement DOT-FA70WAI-175 as part of AF Project 649E under Contract F19628-70-C-0291 by the staff of the IIT Research Institute at the Department of Defense Electromagnetic Compatibility Analysis Center.

To the extent possible, all abbreviations and symbols used in this report are taken from American Standard Y10.19 (1967) "Units Used in Electrical Science and Electrical Engineering" issued by the United States of America Standards Institute.

Users of this report are invited to submit comments which would be useful in revising or adding to this material to the Director, ECAC, North Severn, Annapolis, Maryland 21402, Attention ACV.

Reviewed by:



G. MORGAN
Project Engineer



J. M. DETERDING
Director of Technical Operations

Approved:



G. Q. NICHOLSON
Colonel, USAF
Director



M. A. SKEATH
Special Projects
Deputy Director

ACKNOWLEDGMENT

The following personnel at the Electromagnetic Compatibility Analysis Center contributed significantly to the model reported herein:

- L. Kuehn of the IIT Research Institute
- T. Bode of the IIT Research Institute
- R. Cleaver of the IIT Research Institute
- A. Herd of the IIT Research Institute

In addition, the assistance of Mr. R. Bock of the Federal Aviation Administration, who provided guidelines with respect to operational considerations as well as advice concerning the application of the model, is gratefully acknowledged.

ABSTRACT

An interference prediction model developed for use in evaluating expected interactions between avionics equipments on an airplane is described. The model is substantially automated and includes subroutines which calculate expected path losses between aircraft antennas and the rejection offered by the receivers to the undesired emissions from transmitters on the aircraft.

An analysis of the interactions between the equipments installed on an FAA Sabreliner has been made using the prediction model and the results of the analysis are described.

Requirements for expansion of the prediction model are established.

KEYWORDS

ANTENNA COUPLING
AIRFRAME COUPLING
SABRELINER AIRCRAFT
COSITE
PERFORMANCE MODELS

TABLE OF CONTENTS

Subsection	Page
SECTION 1	
INTRODUCTION	
BACKGROUND	1- 1
OBJECTIVES	1- 1
CONSTRAINTS	1- 2
SECTION 2	
RESULTS AND CONCLUSIONS	
RESULTS	2- 1
CONCLUSIONS	2- 1
SECTION 3	
ANALYSIS	
SABRELINER DESCRIPTION	3- 1
Analysis Techniques	3- 1
Transmitted Power, P_T	3- 5
Antenna Gains, G_T, G_R	3- 5
Path Loss, L_p	3- 6
Expected Error in L_p	3-12
Sabreliner Coupling Loss Predictions	3-13
Receiver Rejection, L_f	3-16
Receiver Response Synthesis	3-16
Receiver Tuned Frequency, f_R	3-19
IF Bandwidth, B_r	3-19
IF Skirt Slope, N_1	3-19
RF Skirt Slope, N_2	3-20

TABLE OF CONTENTS (Cont.)

Subsection	Page
Spurious Response Rejection, K_S	3-22
Spurious Response Limit Frequencies, f_a, f_b	3-25
Transmitter Spectral Emission Synthesis	3-25
Communications Transmitters	3-27
Pulsed Transmitters	3-27
Harmonic Emissions	3-29
Rejection Calculation	3-29
Degradation Thresholds, $(S/I)_T$	3-32
Communications Receivers	3-32
Navigation Receivers	3-33
DME, TACAN Receivers	3-33
ATC Transponder Receiver	3-34
Radar Receivers	3-34
Receiver Sensitivity, R_S	3-34
SUMMARY	3-34

SECTION 4

PROGRAM UTILIZATION

Input Data	4- 1
General Parameter Card	4- 1
Transmitter Data Cards	4- 2
Receiver Data Cards	4- 5
Output Formats	4- 6
Suggested Operating Procedures	4-10
First Level Analysis	4-10
Second Level Analysis	4-11
Third Level Analysis	4-12
Additional Applications	4-13

TABLE OF CONTENTS (Cont.)

Subsection	Page
SECTION 5	
SABRELINER EMC EVALUATION	
INTRODUCTION	5- 1
First Level Analysis Results	5- 1
Second Level Analysis Results	5- 1
Third Level Analysis Results	5- 2
TACAN Transmitter Effects on the ATC Transponder	5- 2
ATC Transponder Effects on the TACAN Receiver	5- 2
Mutual Effects Between TACAN Systems	5- 4
Mutual Interactions Between the VHF Communications Equipments	5- 4
VHF Communications Transmitter Effects on the VHF Navigation Receivers	5- 4
Effects of the UHF Transmitter on the Glide Slope Receivers	5- 5
Expected Effects of Future VHF SATCOM Terminal	5- 5

SECTION 6

MODEL EXPANSION POSSIBILITIES

GENERAL	6- 1
Antenna Gain Calculator	6- 1
Improvement In Coupling Loss Predictions	6- 1
Input Preprocessor	6- 2
Statistical Prediction Model	6- 2
Suggested Improvement Sequence	6- 2

LIST OF ILLUSTRATIONS

Figure	Page
3- 1. FAA Sabreliner Antenna Complement	3- 2

LIST OF ILLUSTRATIONS (Cont.)

Figure		Page
3- 2.	Curvature Factor, F(y) versus y.	3-10
3- 3.	Receiver Relative Response Characteristic	3-17
3- 4.	Relative Spectral Emission Envelope Characteristic	3-25
4- 1.	Typical Output Data	4- 7

LIST OF TABLES

Table		Page
3- 1	SABRELINER EQUIPMENT COMPLEMENT	3- 1
3- 2	INPUT ANTENNA GAINS	3- 7
3- 3	POLARIZATION MISMATCH LOSSES	3-14
3- 4	PREDICTED SABRELINER EFFECTIVE COUPLING LOSSES	3-15
3- 5	RELATIVE TRANSISTOR MIXER CONVERSION LOSS IN dB	3-24
3- 6	RESULTS OF VOICE INTELLIGIBILITY TESTS	3-33
4- 1	GENERAL PARAMETER INPUT CARD FORMAT	4- 1
4- 2	TRANSMITTER DATA CARD FORMATS	4- 2
4- 3	RECEIVER DATA CARD FORMATS	4- 5
5- 1	FIRST LEVEL ANALYSIS RESULTS	5- 1

LIST OF APPENDICES

Appendix

- I COUPLING LOSS SUBROUTINE
- II COUPLING LOSS MEASUREMENT PROCEDURES
- III FREQUENCY ANALYSIS SYSTEM (FAS) SUBROUTINE
- IV AVPAK PROGRAM
- V SABRELINER FIRST LEVEL ANALYSIS OUTPUT DATA

- VI REFERENCES
- VII DD FORM 1473

SECTION 1

INTRODUCTION

BACKGROUND

The Federal Aviation Administration (FAA) has established a requirement for the development of a general analytical capability to determine the mutual effects resulting from the introduction of new avionics equipment to an existing airframe containing operational equipment. Accordingly, the Electromagnetic Compatibility Analysis Center (ECAC) (See Reference 1) agreed to develop an analytical modular model capability for the FAA which will enable rapid evaluation of these effects as the need arises.

In accordance with the specified agreement, the ECAC was to develop the capability to evaluate the mutual effects of the avionics packages associated with the FAA Sabreliner aircraft, specifically, and then to generalize the resulting models such that they may be applied to any other airframe/avionics configuration.

The FAA Sabreliner is a specially equipped aircraft used to monitor and evaluate performance of ground-based electronic navigational aids in the United States. The complement of radio and navigational equipment associated with the Sabreliner is summarized in TABLE 3-1. These were the specific units treated in this initial development.

OBJECTIVES

The objectives of this program were to:

- a. Develop an automated airframe coupling model.
- b. Develop performance models for the Sabreliner avionics equipment and, where possible, generalize these models to enable application to other similar types of equipment.
- c. Establish requirements for future modeling activity.
- d. Perform an analysis of the FAA Sabreliner so that it may be used as a validation model for the developed analytical capability.
- e. Determine the expected mutual effects resulting from the installation of a VHF Satcom terminal on the Sabreliner.

CONSTRAINTS

The interference prediction model reported herein considers only antenna coupled interference. Interactions due to cable coupled interference, and effects due to interference radiated directly between equipments on the airplane, are not considered.

SECTION 2

RESULTS AND CONCLUSIONS

RESULTS

1. A modularized antenna coupled interference prediction model was developed which is substantially automated.
2. The program includes an automated coupling model which predicts the path losses between antennas on an airframe and an automated subroutine which calculates the effective rejection offered to undesired signals by the receiving systems.
3. An analysis was made of the expected mutual effects between the avionics equipments aboard the FAA Sabreliner flight inspection aircraft.
4. The expected effects resulting from the installation of an additional system, a proposed VHF Satellite Communications (SATCOM) terminal, were evaluated.
5. A test plan for validation of the predicted coupling losses was proposed.

CONCLUSIONS

1. The existing avionics complement aboard the Sabreliner is capable of compatible operations, provided the frequency relationships identified in Section 5 are avoided. (See Section 5).
2. A VHF SATCOM terminal may be added to the Sabreliner complement without adverse effects, provided its operating frequency is above 133 MHz. (See Section 5).
3. The prediction model described herein is amenable to expansion and generalization to enable solution of situations involving aircraft-to-aircraft and aircraft-to-ground environment equipment as well as the intra-aircraft problem for which it was designed.

SECTION 3

ANALYSIS

SABRELINER DESCRIPTION

The FAA Sabreliner aircraft is a special version of the North American Rockwell Series 40 Sabreliner which has been equipped as a flight inspection facility. The radio and navigation equipment associated with the aircraft is summarized in TABLE 3-1.

TABLE 3-1
SABRELINER EQUIPMENT COMPLEMENT

Equipment	Quantity	Manufacturer	Function
RTA-41B	2	Bendix	VHF Communications
DF-203	2	Collins	Automatic Direction Finding
51Z-4	1	Collins	Marker Beacon Receiver
WP-103A	1	Collins	Weather Radar
AVQ-65	1	RCA	ATCRBS Transponder
DRA-12	1	Bendix	Doppler Navigation Radar
RNA-26CF	3	Bendix	VOR/LOC Receivers
ALA-51	1	Bendix	Radio Altimeter
AN/ARC-109	1	Collins	UHF Communications
618T-3	1	Collins	HF Communications
RT-870/ARN-91	2	Hoffman	TACAN System

An illustration of the Sabreliner indicating the location and description of the antennas associated with these systems is shown in Figure 3-1.

Analysis Techniques

The analysis of the mutual effects of the operation of the equipment on the Sabreliner, including the analysis done by the automated computer model developed to assist in the effort, was accomplished by predicting the expected level of degradation relative to the degradation threshold of each receiver. The procedure used in the prediction process is

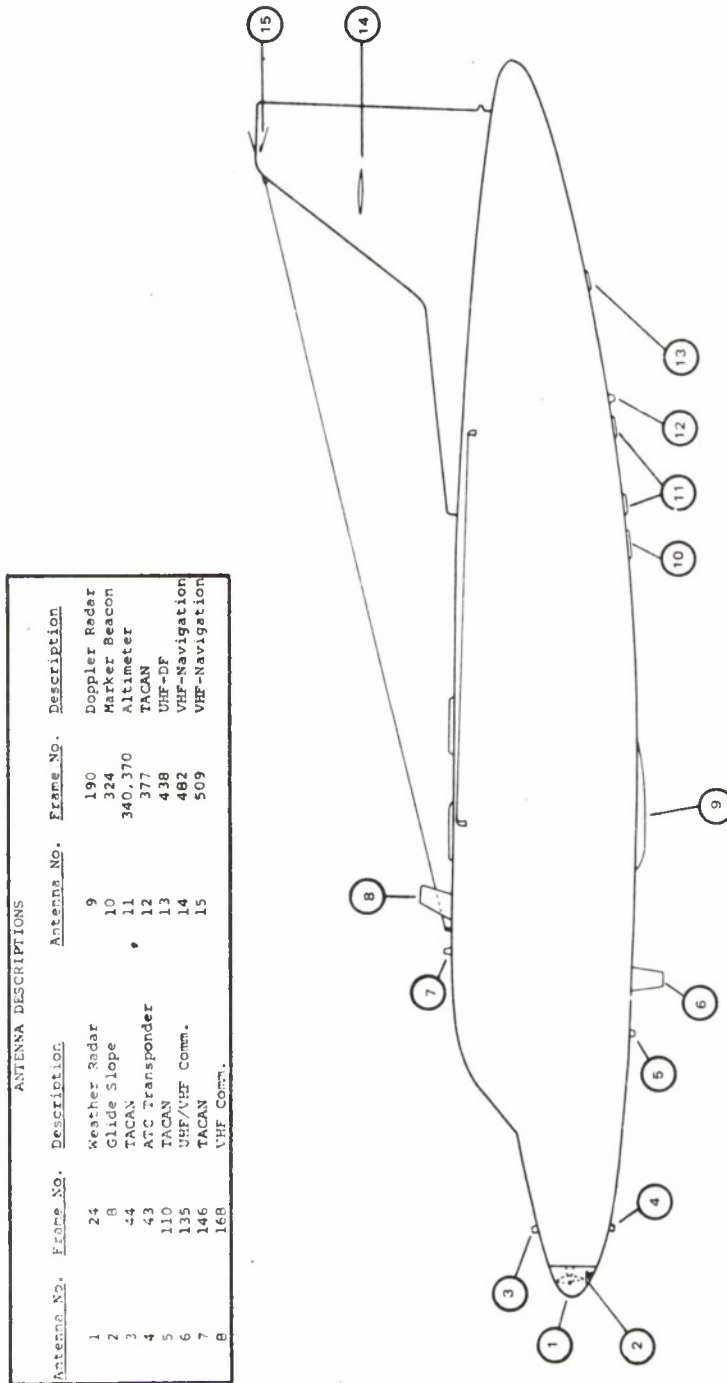

Figure 3-1. FAA Sabreliner Antenna Complement.

described below. Units for frequency and bandwidth, unless otherwise stated, are the same.

The undesired interfering power at the input terminals of a potential victim receiver can be calculated with the logarithmic form of the one-way system loss equation which is:

$$P_i = P_T + G_T + G_R - L_p - L_s \quad (3-1)$$

where;

P_i	=	the input interfering power in decibels relative to one milliwatt (dBm).
P_T	=	the transmitter output power in dBm.
G_T	=	the effective gain of the transmitting antenna in the direction of the receiving antenna in dB relative to an isotropic radiator (dBi).
G_R	=	the effective gain of the receiving antenna in the direction of the transmitting antenna in dB relative to an isotropic radiator.
L_p	=	the path loss between isotropic radiators in dB.
L_s	=	the combined system losses associated with the transmitter and receiver due to transmission lines, coupling devices, and external RF filtering in dB.

In the interest of conservatism, the system losses can usually be neglected without introducing significant errors. It was assumed herein that such losses are negligible. Therefore, the L_s term was dropped from further consideration at this time, but the capability to include such a factor has been retained for future application.

The effect of this interfering power depends on the response characteristics of the receiver circuitry prior to the detector and the input signal-to-interference ratio (S/I) required by the receiver to perform without degradation in the presence of such an

interfering signal. This effect can be represented by:

$$R = A - L_f \quad (3-2)$$

where:

R = the response of the receiver circuitry to the input interfering signal in dB.

A = the response of the receiver to its desired signal in dB.

L_f = the response to the interfering signal relative to the response to the desired signal offered by the receiver in dB, i.e., the rejection offered by the receiver to the undesired signal.

If equation (3-2) is normalized to A and combined with (3-1), then

$$P_{ie} = P_T + G_T + G_R - L_p - L_f \quad (3-3)$$

where:

P_{ie} = the effective input interfering signal in dBm, which has been normalized relative to an undesired signal with the same characteristics as the desired signal.

In other words, the minimum level of an input desired signal required to produce a standard response is defined as the receiver sensitivity. If the interfering signal has different characteristics than the desired signal, the input level required to produce a standard response is different. This difference in levels can be considered as an on-tune receiver rejection factor for the interfering signal. The consideration of this factor with any additional off-frequency rejection resulting from the selectivity characteristic of the receiver can be considered as a total receiver rejection factor for the interfering signal.

The level of degradation caused by this signal can be evaluated by comparing the resulting signal-to-interference ratio to the required threshold S/I ratio. If it is assumed that the input desired signal is at the receiver sensitivity level, then the degradation level is:

$$P_{Id} = P_{ie} - R_s + (S/I)_T \quad (3-4)$$

where:

P_{Id} = the degradation level relative to the threshold of the degradation in dB.

R_s = the sensitivity of the receiver in dBm.

$(S/I)_T$ = the threshold input signal-to-interference ratio, in dB, required to prevent degradation.

If equations (3-3) and (3-4) are combined, then

$$P_{Id} = P_T + G_T + G_R - L_p - L_f + (S/I)_T - R_s \quad (3-5)$$

where all of the terms have been defined.

If P_{Id} is greater than zero, then degradation is expected to occur; conversely, if P_{Id} is less than zero, degradation is not expected and further consideration need not be given to interactions between the particular transmitter and receiver involved.

Equation (3-5) is the expression solved by the analyst when studying a potential interference problem and by the developed automated program up to the point where a detailed manual analysis is required. Each of the terms in equation (3-5) is discussed below.

Transmitted Power, P_T

This parameter is a required input to the program and represents the average output power in dBm for communications transmitters and the peak output power for pulsed transmitters. This information can be obtained from the nominal characteristics of the equipment or from measured data.

Antenna Gains, G_T , G_R

These parameters are also required inputs to the program at the present time and they represent the expected gain to be realized along the propagation path between the antennas on the airframe. It is important to note that, since the area of consideration is confined to the intra-aircraft problem; the perturbations in the antenna patterns observed at great

distances from the aircraft, which are caused by irregularities in the airframe shape, are not expected to be realized. Further, since it is difficult, if not impossible, to measure the radiation pattern of antennas when the observation points as well as the antennas are located on the same aircraft, the values recommended for use in the program are the maximum theoretical values to be expected along the surface of the airframe in the direction of the transmission path between the antennas under consideration.

For non-aperture types of surface mounted antennas, such as monopoles, dipoles, blades, and loop antennas, the gain to be used is the maximum theoretical gain in the horizontal plane.

For aperture type antennas, such as parabolic reflectors, phased arrays, and horns, whose direction of maximum radiation is broadside to the airframe, the appropriate value to be used for the antenna gain is the value in the sidelobe or backlobe which is directed along the surface of the aircraft.

Certain of the values to be used can be obtained from manufacturer's data. When it is necessary to calculate the value theoretically, the expressions to be used can be obtained from References 2 and 3. The antenna gains used in this analysis are shown in TABLE 3-2. These gain characteristics are expected to be representative of most of the antennas used on airplanes for the indicated functions.

The specification of the antenna gains as required inputs for the automated model is consistent with the modular concept and enables greater flexibility for generalization of the prediction program. For example, if, in the future, the model is expanded to enable evaluation of mutual effects in inter-aircraft and aircraft-to-ground equipment considerations, an antenna gain calculation subroutine could be developed and included in the overall model. Such a subroutine could either be deterministic or statistical.

Path Loss, L_p

The path loss between isotropic radiators on an airframe is calculated using the technique reported by Hasserjian and Ishimaru (See Reference 4) and extended by Khan et al (See Reference 5). These efforts have shown that the path loss along a conducting curved surface can be calculated by:

$$L_{pc} = L_{pf} F(\gamma) \quad (3-6)$$

TABLE 3-2
INPUT ANTENNA GAINS

Antenna No.	Function	Type	Polarization	Gain (dBi)
1	Weather Radar	Parabolic	Horizontal	-10
2	Glide Slope	Dipole	Horizontal	2
3	TACAN	Blade	Vertical	2
4	ATC	Blade	Vertical	2
5	TACAN	Blade	Vertical	2
6	VHF/UHF Comm.	Blade	Vertical	2
7	TACAN	Blade	Vertical	2
8	UHF Comm.	Blade	Vertical	2
9	Doppler Radar	Array	Linear	-20
10	Marker Beacon	Loop	Horizontal	-5
11	Altimeter	Horn	Horizontal	-20
12	TACAN	Blade	Vertical	2
13	UHF-DF	Loop	Vertical	2
14	VOR/ILS	Loop	Horizontal	2
15	VOR/ILS	Dipole	Horizontal	2

where;

L_{pc}	=	the path loss along the curved surface of the airframe.
L_{pf}	=	the path loss along the same surface when flattened into a plane.
$F(y)$	=	the loss factor due to the curvature of the surface, i.e., the curvature factor.

The curvature factor, $F(y)$, is a complex infinite series in y which depends on the geometrical parameters of the path (See Reference 5).

The function y is:

$$y = R_1^{3/2} / \rho_1 \quad (3-7)$$

where:

R_1	=	the length of the curved ray path as normalized by the wave number, i.e. R_1 equals k times D_1 , where D_1 is the curved ray path and $k = 2\pi/\lambda$, where λ is the wavelength.
ρ_1	=	the curvature of the ray path as normalized by the wave number.

The parameter y is described below for various geometrical shapes found in practical airframes:

$$y = K^{1/2} a \phi^2 / \left[(\Delta Z)^2 + (a\phi)^2 \right]^{1/4} \text{ for a cylinder;} \quad (3-7a)$$

$$y = (Ka)^{1/2} \phi^{3/2} \text{ for a sphere,} \quad (3-7b)$$

$$y \cong K^{1/2} (a_i a_j)^{1/2} \phi^2 / \left[(\Delta Z)^2 + a_i a_j \phi^2 \right]^{1/4} \text{ for a cone,} \quad (3-7c)$$

where:

a	=	the radius of the cylinder or sphere.
-----	---	---------------------------------------

a_i	=	the radius of the cone at the i th antenna location.
a_j	=	the radius of the cone at the j th antenna location.
ΔZ	=	the distance between the antennas along the axis of the cylinder or cone.
ϕ	=	the angle in radians between the antennas on a plane defined by the two antennas and the center of the airframe.

The coordinate system used in describing these parameters and the solution of the magnitude of $F(y)$ versus y in decibels are shown in Figure 3-2.

The path loss between the antennas on the surface when it has been flattened into a plane is calculated using the free space formula:

$$L_{pf} = 20 \log f_{\text{MHz}} + 20 \log D_1 - 38 \quad (3-8)$$

where

$$L_{pf} = \text{the free space loss between isotropic radiators in dB.}$$

$$f_{\text{MHz}} = \text{the transmitted frequency in megahertz (MHz).}$$

$$D_1 = \text{the ray path distance along the surface between the antennas in feet.}$$

The distance, D_1 , for the various geometrical shapes is:

$$D_1 = a\phi \text{ for a sphere,} \quad (3-9a)$$

$$D_1 = \left[(\Delta Z)^2 + (a\phi)^2 \right]^{1/2} \text{ for a cylinder,} \quad (3-9b)$$

$$D_1 \cong \left[(\Delta Z)^2 + a_i a_j \phi^2 \right]^{1/2} \text{ for a cone,} \quad (3-9c)$$

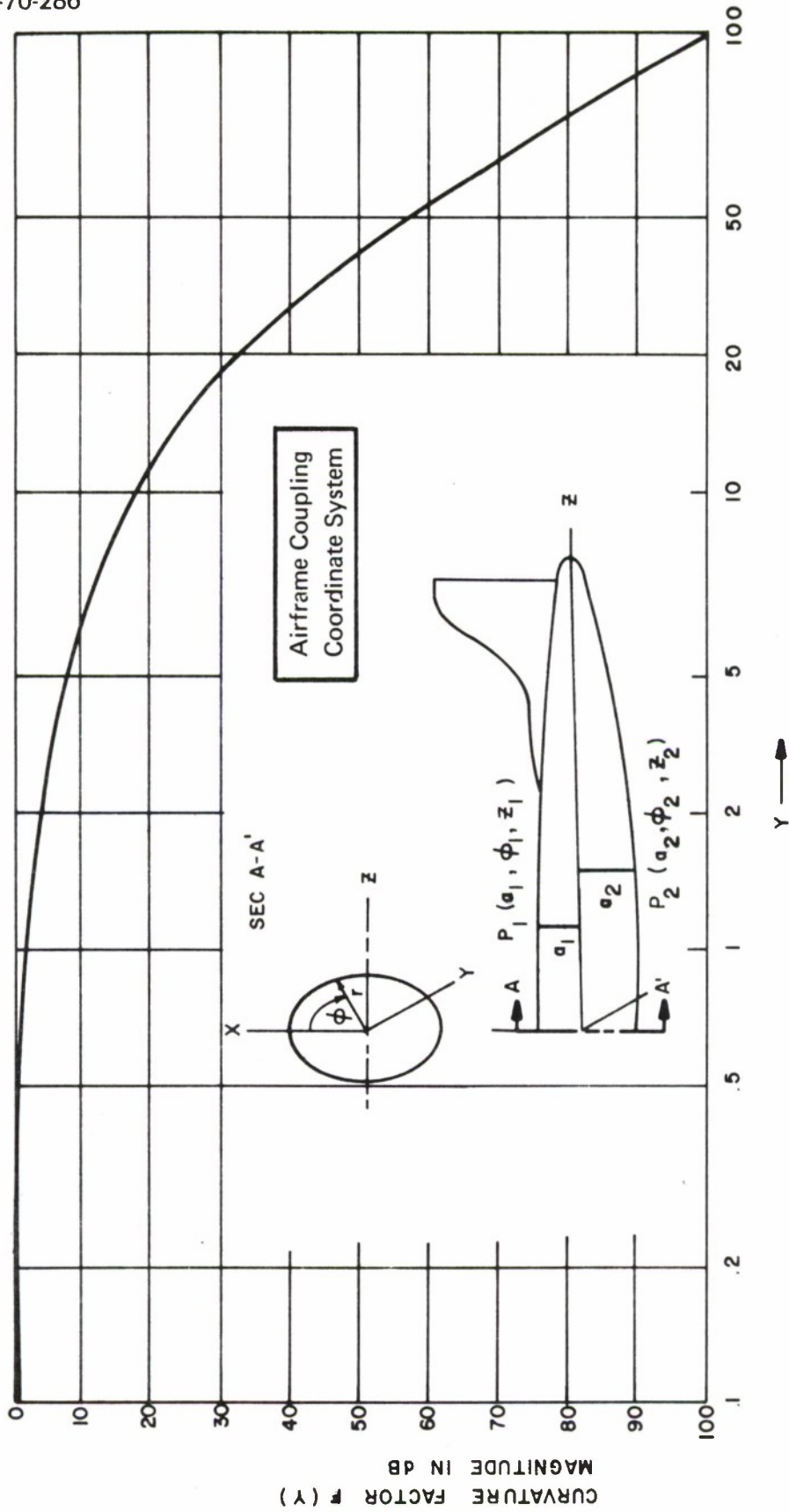

Figure 3-2. Curvature Factor, $F(y)$ versus y .

where all of the terms have previously been defined.

It should be noted that the expressions shown for an airframe shaped like a conical cylinder, are approximations rather than exact relationships. The reason for this situation is that one of the restrictions in the technical development of the curvature factor is a requirement that the curvature along the ray path between the antennas remain constant. When the antennas lie on a conical surface, this requirement is not completely satisfied. In practical airframes, however, it can be shown that the ray path length can be calculated with a high degree of accuracy by treating the cone as a modified cylinder with a radius equal to the geometric mean of the radii of the cone at the locations of the antennas. The limitation of this approximation is that the apex angle of the cone cannot exceed 20 degrees. This limitation is satisfied for the Sabreliner where the apex angle is approximately 14 degrees. This result leads intuitively to the finding that the curvature factor between two antennas on a cone lies between those factors which would be calculated if the cone were replaced by two cylinders having radii equal to the cone radii at each of the two antennas.

When this type of computation is made for the worst case situation found on the Sabreliner, it is found that the theoretical error to be expected in the total coupling loss lies in the range of 0 - 2dB. This minimal error occurs when determining the total loss between the VHF antenna mounted on the top centerline and the UHF direction-finding antenna mounted on the bottom centerline.

The remaining restrictions which affect the application of this technique include geometrical limitations which insure that the respective antennas do not lie within each others Fresnel (near-field) region. These geometrical restrictions place a lower limit on the frequencies at which the coupling loss can be calculated. For example, the HF wire antenna, the Sabreliner airframe length, and the high-frequency wavelengths are all of comparable magnitude. As a result the entire airframe can be expected to be a part of the HF antenna system. Any considerations of the coupling loss to be expected along the airframe, consequently become intra-antenna system (near-field) considerations. Thus, this technique cannot be applied to HF systems. In fact, there is no known practicable analytic solution to this type of problem.

The expressions given above for circular cylinders and conical-cylinders have been automated. This automated model is used as a subroutine in the overall interference prediction model. Additional details of the program, including the mathematical development of the geometrical considerations involved, are contained in Reference 6.

The input data required for this subroutine are:

- a. Z_i = The frame number of the i th antenna. This corresponds to a Z axis dimension in inches.
- b. ϕ_i = The angle around the airframe of the i th antenna location in degrees, using the top centerline as the zero degree reference.
- c. f_i = The operating frequency of the transmitter associated with the i th antenna in MHz.
- d. The antenna height in feet from the centroidal axis of the airframe, i.e., the radius of the airframe at the i th antenna.

For those considerations involving the losses between the navigational antennas on the vertical stabilizer and the transmitting antennas along the bottom centerline of the fuselage, the path is considered to be composed of a partial freespace path between the stabilizer antenna and a point on the surface of the fuselage, and then a remaining surface wave path along the fuselage. The point of tangency satisfying the required conditions for the shortest path between the antennas is computed, the characteristics of each portion of the path are determined, and then the total loss is calculated using the same techniques previously described. The expressions used to evaluate these paths are explained in Reference 6.

Logical flow diagrams and a program listing written in the Fortran V language are contained in APPENDIX I.

Expected Error in L_p

Previous measurements have been made to validate predictions made with this technique. A total of 121 measurements were made in a KC-135 aircraft in the UHF (225-400 MHz) portion of the spectrum. The results of the validation effort may be summarized as follows:

1. Of the 121 measurements, only two were considered suspect and omitted from the comparison.
2. The mean error between the predictions and the remaining 119 observations was 0.5 dB and the standard error was 4 dB.
3. The distribution of the errors appears to be normal about a mean of 0 dB with a standard deviation of 4 dB, based on a chi-squared test at a 0.05 significance level. Further details on these data are contained in Reference 6.

Sabreliner Coupling Loss Predictions

Since an isotropic radiator does not exist, the path loss between two such antennas cannot be measured. However, an effective coupling loss, which includes the effect of the respective antenna radiation characteristics can be measured.

The effective coupling loss can be calculated from the following equation:

$$C_e = G_{Te} + G_{Re} + P - L_p \quad (3-10)$$

where:

C_e = the transmission loss between the transmitting and the receiving antennas in dB.

G_{Te}, G_{Re} = the effective gain relative to an isotropic antenna of the transmitting and receiving antennas in the direction of the ray path between the antennas.

P = the polarization mismatch between the antennas.

L_p = the path loss as previously defined.

Polarization mismatches, P , which can be expected are shown in TABLE 3-3. These values have been used in this analysis for the non-aperture antennas. For the aperture antennas, the values are appropriate only when considering the radiation in the mainbeam of the pattern. When sidelobe or backlobe radiation is being considered, no polarization mismatch is assumed to exist. These correction factors are not currently included in the automated model. They could, however, be included in any antenna gain calculation subroutine which might be developed in the future.

In addition to the parameters discussed above, an additional factor must be considered in connection with the paths between the antennas located in front of the metal nose bulkhead, and the antennas behind the bulkhead. A knife-edge diffraction loss can be expected along these paths due to the obstruction created by the bulkhead. Bullington presents a nomograph which can be used to calculate these losses (See Reference 2, Chapter 33). This nomograph has been automated in equation form and this additional loss factor is automatically included when the transmission path crosses the nose bulkhead.

The equation used is

$$L_K = 10 \log h^2 f / 20d \quad (3-11)$$

where:

- L_K = the knife-edge diffraction loss in dB.
- h = the height of the obstruction above the line-of-sight path in feet.
- f = the transmitted frequency in megahertz.
- d = the distance between the bulkhead and the nearest antenna under consideration in feet.

TABLE 3-3
POLARIZATION MISMATCH LOSSES

Transmitting Antenna Polarization	Polarization Mismatch Loss (dB Receiving antenna Polarization			
	Horizontal	Vertical	Linear	Circular
Horizontal	0	-20	-3	-3
Vertical	-20	0	-3	-3
Linear (45°)	-3	-3	0	0
Circular	-3	-3	0	0

The predicted effective coupling losses in dB between the antennas on the Sabreliner are shown in TABLE 3-4. The antennas are numbered as shown in TABLE 3-2 and may be identified by referring to that table.

TABLE 3-4
 PREDICTED SABRELINER EFFECTIVE COUPLING LOSSES

Transmitting Antenna and Nominal Frequency	Effective Coupling Loss in dB Receiving Antenna														
	1	2	3	4	5	6	7	8	9	10	11	12	13	14	15
1 - 9315 MHz	-	*	82	78	93	96	98	100	112	113	129	107	109	110	111
3 - 1025 MHz	54	66	-	57	55	78	39	40	96	102	84	72	74	70	71
4 - 1090 MHz	49	55	57	-	34	37	78	78	76	73	70	48	49	70	71
5 - 1025 MHz	65	64	55	34	-	24	80	79	63	70	67	46	47	85	85
6 - 135 MHz	40	44	30	19	11	-	38	37	39	51	49	27	29	57	57
6 - 300 MHz	51	55	42	26	18	-	54	53	46	59	56	34	36	67	67
7 - 1025 MHz	70	76	39	78	80	80	-	22	100	103	95	72	70	68	68
8 - 135 MHz	44	59	23	38	37	37	5	-	59	65	60	38	37	49	50
9 - 8800 MHz	121	96	135	81	76	72	176	176	-	87	105	83	85	131	128
11 - 4300 MHz	118	96	110	81	78	77	132	133	101	63	-	64	71	114	111
12 - 1025 MHz	80	78	72	48	46	45	73	73	64	60	36	-	31	80	80

*Note: These antennas are spaced too closely to enable a prediction.

It is suggested that the accuracy of the predictions be established. A test plan setting forth procedures which can be used to validate these predictions is contained in APPENDIX II. Briefly, the plan contains two methods for obtaining the coupling losses between antennas on the Sabreliner. One of the methods is a directly indicating technique which may be used for the losses at frequencies below 1000 MHz. The second method is a signal substitution technique suitable for use at frequencies above 1000 MHz. Equipment types and layouts are described in the plan and sequential procedures for determining the losses are presented.

Receiver Rejection, L_f

The rejection offered to an undesired emission by a potential victim receiver is calculated by a subroutine known as the Frequency Analysis System (FAS). A simplified explanation, which is largely intuitive, is given herein. This treatment will enable the reader to understand the operation of FAS and will prepare him for the more detailed information, including a purely mathematical presentation, given in Reference 7.

For a given transmitter-receiver pair, FAS synthesizes the receiver response characteristic and the transmitter spectral emission characteristic by a series of line segments which are linear on a logarithmic scale. Each of these synthesized models is normalized to unity at the tuned frequency of the equipment such that the characteristics described are relative to the performance at the tuned frequency. When this synthesis is complete, FAS determines the rejection by integrating over the areas of frequency overlap between the transmitted emission and the receiver response. Two cases are considered. The first case examined involves a calculation of the relative energy transfer to be expected due to the emission sidebands which lie within the passband of the receiver. The second case examined is the expected energy transfer resulting from inadequate receiver selectivity at the frequencies within the fundamental emission bandwidth of the transmitter. These two cases are compared and the worst situation, i.e. the least amount of rejection, is chosen as the appropriate rejection for the given equipment pair.

Receiver Response Synthesis

The receiver relative response characteristic is synthesized by four line segments, which are linear on a logarithmic scale, and appears as shown in Figure 3-3.

The parameters shown are defined as:

f_R	=	the tuned frequency of the receiver.
B_r	=	the intermediate frequency (IF) bandwidth of the receiver.
N_1	=	the slope of IF selectivity skirt in dB per decade.

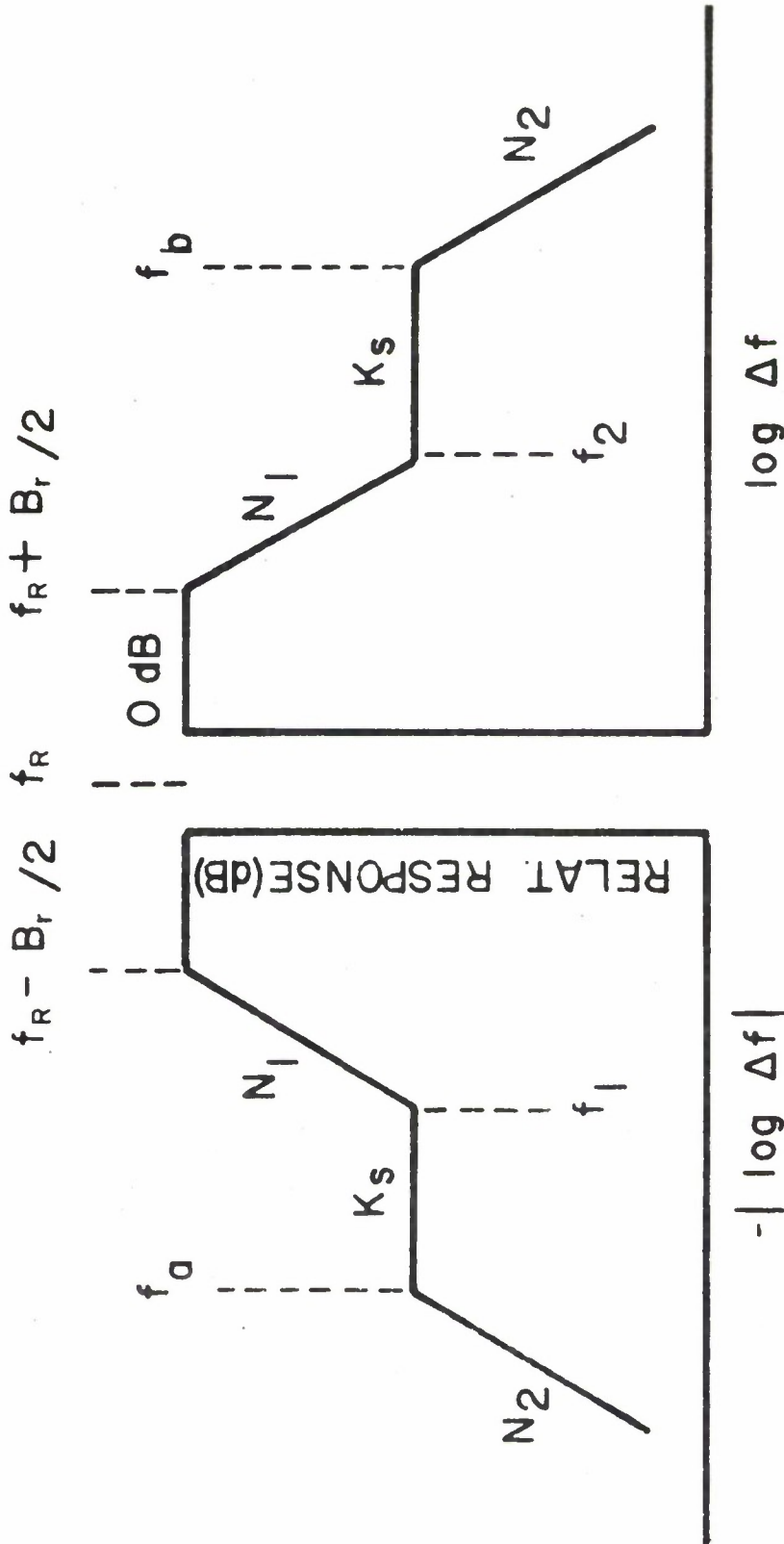

Figure 3-3. Receiver Relative Response Characteristic.

- f_1, f_2 = the lower and upper frequencies, respectively, where spurious responses must be considered. These frequencies should be selected to coincide with the intersection of the K_s level with the IF selectivity curve.
- k_s = the spurious response rejection of the receiver.
- f_a, f_b = the lower and upper frequencies, respectively, at which spurious responses need no longer be considered. These frequencies should be selected to coincide with the intersection of the K_s level with the RF circuitry selectivity curve.
- N_2 = the slope of the RF selectivity skirt in dB per decade.

The response characteristic may be expressed mathematically as:

$$r(f) = 1, \text{ when } \left(f_R - \frac{B_r}{2} \right) < f < \left(f_R + \frac{B_r}{2} \right) \quad (3-12a)$$

$$r(f) = \left(\frac{\frac{B_r}{2}}{f - f_R} \right)^{n_1}, \text{ when } f_1 < f < f_R - \frac{B_r}{2}, \quad (3-12b)$$

$$\text{or } f_2 > f > f_R + \frac{B_r}{2}$$

$$r(f) = k_s, \text{ when } f_a < f < f_1 \quad (3-12c)$$

$$\text{or } f_b > f > f_2$$

$$r(f) = k_s \left(\frac{f_b - f_R}{f - f_R} \right)^{n_2}, \text{ when } f_b < f \quad (3-12d)$$

$$r(f) = k_s \left(\frac{f_a - f_R}{f - f_R} \right)^{n_2}, \text{ when } f < f_a \quad (3-12e)$$

where:

$r(f)$ = the relative response of the receiver at frequency f

Then:

$R(f)$ = the relative response in dB where $R(f) = 10 \log r(f)$, and

K_s = $10 \log k_s$.

N_1, N_2 = $10 n_1, 10 n_2$ respectively

Except for f_1 and f_2 , the parameters shown are required inputs for the FAS subroutine. Methods of determining these parameters are explained below.

Receiver Tuned Frequency, f_R

The tuned frequency of the receiver is obtained from the frequency assignment appropriate to the receiver being considered.

IF Bandwidth, B_r

The intermediate frequency bandwidth is obtained from the nominal characteristics of the receiver, usually set forth in the manufacturer's data or Technical Manual describing the equipment, or it is obtained from measured data.

IF Skirt Slope, N_1

This parameter is extracted from the given IF selectivity characteristics. It is the slope of the skirt in dB per decade. For example, the nominal characteristics of a receiver may specify that the IF selectivity of a receiver has a 20 dB bandwidth of BW_1 and a 60 dB bandwidth of BW_2 . Then n_1 is obtained from:

$$(60 - 20) \text{ dB} = 40 \text{ dB} = 10 n_1 \log \frac{BW_2}{BW_1} \quad (3-13a)$$

and,

$$N_1 = \frac{40}{\log \frac{BW_2}{BW_1}} \quad (3-13b)$$

RF Skirt Slope, N_2

The characteristics of the RF circuitry usually must be theoretically synthesized, unless measured data are available. However, measured RF characteristics are normally available only as a result of a special effort intended to study such characteristics. Accordingly, two alternate methods for synthesizing the RF selectivity are presented.

The first method requires information concerning the receiver design, i.e., the number of tuned circuits preceding the first mixer in a receiver. This information can be obtained by examination of the circuit diagrams included in the technical manual describing the equipment. When the number of tuned circuits is known, the relative response of the circuitry can be calculated from the following equation:

$$R_{RF} = 20 \log \left[1 + \left(\frac{2 |f - f_R|}{f_R} Q_s \right)^2 \right]^{-n/2} \quad (3-14a)$$

or

$$R_{RF} = -10n \log \left[1 + \left(\frac{2 |f - f_R|}{f_R} Q_s \right)^2 \right] \quad (3-14b)$$

where:

R_{RF} = the response in dB relative to the response at the tuned frequency of the receiver.

n = the number of tuned circuits preceding the first mixer.

f = the frequency at which the relative response is required.

f_R = the tuned frequency of the receiver.

Q_s = the selectivity factor of each tuned stage as defined by:

$$Q_s = \frac{f_R}{2 |f - f_R|_{3dB}} \quad (3-15)$$

where

$$2 |f - f_R|_{3dB} = \text{the 3 dB bandwidth of the stage.}$$

The parameter, Q_s is not generally available and must be estimated. An estimated Q_s of 50 yields sufficiently conservative results for most analyses.

The solution of equation (3-14) as a function of frequency will yield the relative selectivity of the RF circuitry of the receiver. The parameter, n_2 is equivalent to $2n$, where n is the number of tuned circuits or

$$N_2 = 10 n_2 = 20 n$$

In certain cases, the number of tuned circuits preceding the mixer is unknown but the RF 3 dB bandwidth is specified along with the image rejection. When these parameters are given, an alternative method for estimating the RF characteristics can be used.

The image frequency of a receiver is separated from the tuned frequency by twice the intermediate frequency. If an "image bandwidth" is defined as equal to four times the intermediate frequency, i.e., twice the image frequency separation from the tuned frequency, then the parameter N_2 can be approximated by:

$$K_I - 3dB \cong 10 n_2 \log \frac{BW_I}{BW_{3dB}} \quad \text{or,} \quad (3-16a)$$

$$N_{2a} \cong \frac{K_I - 3 dB}{\log \frac{BW_I}{BW_{3 dB}}} \quad (3-16b)$$

where:

- N_{2a} = the approximate value of N_2
- K_I = the image rejection in dB.
- BW_I = the "image bandwidth" defined above (note that this bandwidth is a mathematical device and not a physical reality).
- BW_{3dB} = the specified 3dB RF bandwidth of the receiver.

It should be noted that, since the universal resonance curve, when plotted on a logarithmic scale, is rounded rather than linear in the vicinity of the 3dB bandwidth, the value of N_{2a} obtained from equation (3-16) will be slightly larger than is appropriate. Therefore, this value should be rounded off to the nearest multiple of 20 which is less than that value. Thus, $N_2 = N_{2a}$ rounded down to the nearest multiple of 20. When this value of N_2 is determined, then n , the number of stages, is obtained by dividing by 20. A corresponding value of Q_s for the RF circuitry can then be calculated by:

$$Q_s = Q_o [2^{1/n} - 1]^{1/2} \quad (3-17)$$

where:

Q_s = the effective selectivity factor for each tuned circuit preceding the mixer.

Q_o = the overall selectivity factor for the n tuned circuits.

n = the number of tuned circuits as determined above.

The computation of the two parameters, Q_s and n , results in values which can be used in equation (3-14) above to estimate the RF selectivity characteristics of the receiver.

If neither of these alternatives is feasible due to a lack of information, then a conservative value of 20 should be used for N_2 . This will result in a worst case prediction of the relative response characteristic of the receiver in this region of frequencies.

Spurious Response Rejection, K_s

The minimum spurious response rejection is usually specified in the nominal characteristics of the receiver. If not, a worst case rejection level can be estimated in the following manner. Spurious responses arise in a superhetrodyne receiver when a high level interfering signal combines in the mixer circuitry and a product at or near the intermediate frequency of the receiver is generated. In general, the most sensitive of these responses arise due to the mixing of the incoming signal and the first local oscillator in the first mixer stage. The frequencies at which the interfering signal can excite these responses is given by:

$$f_{sp} = \frac{pf_{lo} \pm f_{IF}}{q} \quad (3-18)$$

where:

- f_{sp} = the frequency of the incoming interfering signal.
- f_{lo} = the injection frequency of the local oscillator.
- f_{IF} = the intermediate frequency of the receiver.
- p = the harmonic of the local oscillator involved in the mix.
- q = the harmonic of the incoming signal involved in the mix.

The fact that the sign preceding f_{IF} in equation (3-18) can take on either sense (\pm) indicates that for a given p, q combination, a pair of responses can be predicted, one for the negative sense and one for the positive sense. In a superheterodyne receiver, the local oscillator frequency, f_{lo} , is related to the tuned frequency, f_R as follows:

$$f_{lo} = f_R \pm f_{IF} \tag{3-19}$$

where the positive sense is appropriate when the oscillator frequency is above the tuned frequency and the negative sense is appropriate when the reverse situation obtains.

The combination of equations (3-19) with (3-18) yields two sets of relationships:

$$\begin{aligned}
 f_{sp} &= \left. \begin{aligned} &\frac{pf_R}{q} + \frac{(p+1)f_{IF}}{q} \\ &\text{and} \\ &\frac{pf_R}{q} + \frac{(p-1)f_{IF}}{q} \end{aligned} \right\} \text{when } f_{lo} > f_R \tag{3-20a}
 \end{aligned}$$

$$\begin{aligned}
 f_{sp} &= \left. \begin{aligned} &\frac{pf_R}{q} - \frac{(p+1)f_{IF}}{q} \\ &\text{and} \\ &\frac{pf_R}{q} - \frac{(p-1)f_{IF}}{q} \end{aligned} \right\} \text{when } f_R > f_{lo} \tag{3-20b}
 \end{aligned}$$

These expressions enable a determination of the frequencies at which an incoming signal can result in the most sensitive spurious responses. Note that when $p=q=1$, the pair of responses which result are the receiver response to its tuned frequency and the response to its image frequency. The relative rejection at the tuned frequency is zero and, from the previous discussion, it is known that the relative rejection at the image frequency is merely the RF rejection at that frequency.

The relative spurious rejection for any other p,q combination is the product of the RF rejection at the incoming frequency, f_{sp} , and the relative mixer conversion loss for the p,q combination being studied. This can be expressed logarithmically as:

$$K_s = R_{RF} \Big|_{f = f_{sp}} + \mu_c \Big|_{p,q} \tag{3-21}$$

where:

K_s = the relative spurious rejection in dB.

R_{RF} = the relative rejection of the RF circuits to f_{sp} in dB.

μ_c = the mixer conversion loss to the actual p,q combination relative to the mixer conversion loss to the $p = q = 1$ combination.

In a previous ECAC measurement effort, representative values of the relative mixer conversion losses for a transistor mixer were established. These values are shown in TABLE 3-5.

TABLE 3-5
RELATIVE TRANSISTOR MIXER CONVERSION LOSS IN dB

P/Q	1	2	3	4	5
1	0	-65	-76	-84	-83
2	-13	-58	-77	-83	-83
3	-13	-65	-77	-81	-82
4	-20	-62	-81	-81	-82
5	-22	-62	-78	-84	-82

The relative spurious rejection level obtained with equation (3-21) for the most susceptible response, excluding the image response, is the value which should be used as an input to the program. The image rejection is also a required input but the image response is treated as a special case when this phenomenon is a potential problem. When this latter situation does arise, the receiver is synthesized around the image frequency in an identical manner to the synthesis about the tuned frequency, except that the relative threshold is reduced by the input image rejection.

Spurious Response Limit Frequencies, f_a, f_b

As stated previously, these frequencies are determined from the point where the K_s level intersects the RF selectivity curve. It should be noted, however, that f_a and f_b are discrete frequencies, rather than frequency separations. Since the RF selectivity is usually specified in terms of response versus frequency separation, the intersection point is more readily obtained in terms of a frequency separation. It is necessary, therefore, to add this separation to (or subtract it from) the receiver tuned frequency to obtain the appropriate values of f_a and f_b . As will be seen later, this situation has ramifications involving different levels of refinement in the analysis.

Transmitter Spectral Emission Synthesis

The synthesis of the envelope of the spectral characteristics of the transmitted emission is synthesized by three line segments which are linear on a logarithmic scale as shown in Figure 3-4.

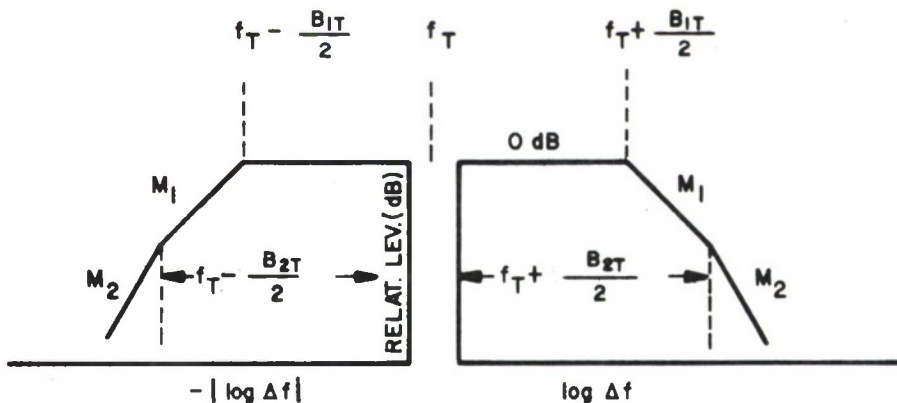

Figure 3-4. Relative Spectral Emission Envelope Characteristic.

The parameters shown are identified as:

- f_T = the tuned frequency of the transmitter.
- B_{1T} = the 3 dB emission bandwidth.
- M_1 = $10 m_1$ the slope of the emission envelope at frequencies adjacent to the 3 dB bandwidth in dB/decade.
- B_{2T} = the emission bandwidth at which the envelope shows a different fall-off characteristic.
- M_2 = $10 m_2$ = slope of the emission envelope at frequencies greatly separated from the tuned frequency in dB/decade.

The emission characteristic may be expressed mathematically as:

$$t(f) = 1 \text{ when } \left(f_T - \frac{B_{1T}}{2} \right) < f < \left(f_T + \frac{B_{1T}}{2} \right) \quad (3-22a)$$

$$t(f) = \left(\frac{\frac{B_{1T}}{2}}{f - f_T} \right)^{m_1} \quad (3-22b)$$

$$\begin{aligned} & \text{when } \left(f_T + \frac{B_{1T}}{2} \right) < f < \left(f_T + \frac{B_{2T}}{2} \right) \\ & \text{or } \left(f_T - \frac{B_{2T}}{2} \right) < f < \left(f_T - \frac{B_{1T}}{2} \right) \\ t(f) &= \left(\frac{B_{1T}}{B_{2T}} \right)^{m_1} \times \left(\frac{\frac{B_{2T}}{2}}{f - f_T} \right)^{m_2} \quad (3-22c) \\ & \text{when } \left(f_T + \frac{B_{2T}}{2} \right) < f \\ & \text{or } f < \left(f_T - \frac{B_{2T}}{2} \right) \end{aligned}$$

where:

- $t(f)$ = the relative level of the spectral emission envelope at frequency f ; and,
- $T(f)$ = $10 \log t(f)$, the relative level in decibels.

Each of these parameters must be specified as inputs to the FAS subroutine and may be determined in the following manner.

Communications Transmitters

The required inputs to enable synthesis of the spectral envelope of communications transmitters may be set forth into two categories, AM and FM cases. The inputs for the AM transmitters are:

B_{1T}	=	$2 f_m$, where f_m is the highest modulation frequency.
M_1	=	80 dB per decade.
B_{2T}	=	$20 f_m$.
M_2	=	20 dB per decade.

The inputs for the FM transmitters are:

B_{1T}	=	$2 f_d$ where f_d is the rated frequency deviation.
M_1	=	80 dB per decade.
B_{2T}	=	$20 f_d$.
M_2	=	20 dB per decade.

The specification of 20 dB/decade for M_2 represents the expected minimum fall-off characteristic of the noise sidebands of these transmitters. If an external RF filter is used in conjunction with the transmitter, the fall-off characteristic of the filter should be added to M_2 .

Pulsed Transmitters

The required inputs for pulsed transmitters can also be categorized into two cases, i.e., pulsed transmitters without frequency modulation during the pulse interval (PO emission), and pulsed transmitters with frequency modulation during the pulse interval, i.e. "chirped"

pulses (P9 emission).

For P0 emissions, the spectral envelope can be found using the methods described in Reference 8. The results are:

$$B_{1T} = 1.28 / (2\tau + t_r + t_f)$$

$$M_1 = \begin{cases} 20 \text{ dB/decade for trapezoidal pulses and} \\ 40 \text{ dB/decade for shaped pulses.} \end{cases}$$

$$B_{2T} = 0.32 \left(\frac{1}{t_r} + \frac{1}{t_f} \right)$$

$$M_2 = 40 \text{ dB/decade,}$$

where:

$$\tau = \text{the pulse width between one-half amplitude points.}$$

$$t_r = \text{the time required for the pulse to rise from its 10 percent amplitude point to its 90 percent amplitude point, i.e., the pulse rise time.}$$

$$t_f = \text{the time required for the pulse to drop from its 90 percent level to its 10 percent level, i.e., the pulse fall time.}$$

The parameters, τ , t_r , and t_f can be obtained from the nominal characteristics of the equipment.

The determination of the envelope parameters of a chirped pulse can be quite complex (See Reference 9), and the resulting emission spectral envelope for such a pulse is not always amenable to a three line segment synthesis technique. However, for most practical cases, the required inputs can be determined as:

$$B_{1T} = f_d \left[1 - \left(\frac{2}{D} \right)^{1/2} \right]$$

where:

$$f_d = \text{the total frequency deviation during the pulse.}$$

D = the Dispersion ratio = τf_d , where τ is the total duration of the pulse.

$$B_{2T} = f_d \left[1 + \left(\frac{2}{D} \right)^{1/2} \right]$$

and:

M_1 = the slope of the line in dB/decade which joins the points $\frac{B_{1T}}{2}$ and $\frac{B_{2T}}{2}$ when those points are plotted on a logarithmic scale.

M_2 = 40 dB/decade.

Harmonic Emissions

In addition to synthesizing the envelope of the spectral characteristics of the fundamental emission of the transmitter, the model also automatically synthesizes the spectral envelopes of the transmitted harmonics up to a maximum of the ninth harmonic. In doing so, the subroutine assumes that the spectral characteristics of each harmonic are identical to that of the fundamental except that the reference point is reduced by a level in dB equal to the attenuation specified as appropriate to the harmonic. The attenuation level for each harmonic to be considered is a required input parameter.

Rejection Calculation

After the receiver response and spectral emission characteristics have been synthesized, and each has been normalized to the level appropriate at the tuned frequency of the equipment, the expected rejection offered by the receiver to the undesired emission can be calculated using only frequency relationships. The development of this concept is given below.

The spectral power density of an emission can be approximated by:

$$P_D = \frac{P_T}{B_{1T}} \tag{3-23}$$

where:

P_D = the spectral density in watts/Hz.

P_T = the average transmitter power in watts.
 B_{1T} = the 3 dB emission bandwidth in Hz.

Thus P_D represents an approximation to the average energy content in the emission. However, the receiver can only intercept that energy for a period of time equal to its "response time". The "response time", τ_R , of a receiver can be considered to be the inverse of its 3 dB bandwidth. Accordingly, the maximum power transfer between a transmitter and receiver can be calculated by:

$$P_r = \frac{P_D}{\tau_R} = \frac{P_T}{B_{1T} (\tau_R)} = P_T \frac{B_R}{B_{1T}} \quad (3-24)$$

where:

P_r = the average received power in watts.
 B_R = the 3 dB bandwidth of the receiver.

The receiver rejection, I_f , is the ratio of the received power to the transmitted power:

$$I_f = \frac{P_r}{P_T} = \frac{B_R}{B_{1T}} \quad \text{or in logarithmic terms,} \quad (3-25)$$

$$L_f = 10 \log I_f = 10 \log \frac{B_R}{B_{1T}}$$

This maximum power transfer occurs when the transmitter and receiver are tuned to the same frequency. Therefore, a co-channel rejection factor $(I_f)_{CO}$ can be defined as:

$$(I_f)_{CO} = \frac{B_R}{B_{1T}} \quad \text{when } B_{1T} > B_R \quad (3-26)$$

and

$$1, \quad \text{when } B_{1T} \leq B_R$$

The reason for the two cases is evident when it is remembered that a receiver cannot receive more power than is transmitted.

It should be noted, however, that the co-channel rejection factor in equation (3-26) has been defined in terms of average power. When the undesired emitter is a pulsed transmitter, the peak received power is usually of more interest than the average received power. Thus for a pulsed transmitter:

$$(P_T)_{avg} = (P_T)_{pk} \tau (PRF) \quad (3-27)$$

where:

$(P_T)_{avg}$ = the average power in watts.

$(P_T)_{pk}$ = the peak power in watts.

τ = the pulse duration in seconds.

PRF = the pulse repetition frequency in hertz.

If equation (3-27) is combined with equation (3-24) then:

$$(P_R)_{avg} = (P_T)_{pk} \tau (PRF) \frac{B_R}{B_{1T}} \quad (3-28)$$

However, in a pulsed transmitter, $\tau \simeq \frac{1}{B_{1T}}$, and the average received power $(P_R)_{avg}$ is related to the peak received power, $(P_R)_{pk}$, by:

$$(P_R)_{avg} = (P_R)_{pk} \tau_R PRF \quad (3-29)$$

where:

τ_R = the response time of the receiver, which is approximately $\frac{1}{B_R}$.

Thus, combining equation (3-29) with equation (3-28) and defining a co-channel rejection factor for pulsed emissions, it is seen that:

$$(I_f)_{co} = \begin{cases} \left(\frac{B_R}{B_{1T}} \right)^2, & \text{when } B_{1T} > B_r \\ \text{and} \\ 1 & \text{when } B_{1T} \leq B_r, \end{cases} \quad (3-30)$$

for considerations involving the peak power transfer due to a pulsed transmitter.

Since the co-channel rejection has been determined, the total rejection, L_f , at any frequency can be calculated by:

$$L_f = (L_f)_{CO} + R(f_T), \quad (3-31)$$

for considerations involving the power transfer resulting the fundamental emission of the transmitter due to inadequate receiver selectivity; and

$$L_f = (L_f)_{CO} + T(f_R), \quad (3-32)$$

for considerations involving the power transfer resulting from the emission sidebands which occur within the receiver passband, where:

$$R(f_T) = \text{the relative response of the receiver at frequency } f_T.$$

$$T(f_R) = \text{the relative emission level of the transmitter at frequency } f_R.$$

The FAS subroutine essentially calculates the value of L_f for each of the situations given above, compares the two values, and selects the lowest of the values obtained for use in equation (3-5). However, since both the relative response characteristic of the receiver and the relative emission levels of the transmitter can vary over a range of frequencies, the computation is made using integration techniques.

Further details on the subroutine, including a rigorous mathematical description of the calculation techniques, are contained in Reference 7. A logical flow diagram and a program listing written in the Fortran V language are contained in APPENDIX III.

Degradation Thresholds, $(S/I)_T$

The input signal-to-interference ratio at which operational degradation begins to occur in a receiver is defined as the degradation threshold and is identified by the symbol $(S/I)_T$. This threshold is a required input parameter for each receiver under consideration.

Communications Receivers

The required signal-to-interference ratios for the receivers used for voice communications were obtained from Reference 10, which contains the results of subjective listener tests made to establish the intelligibility of voice transmissions as a function of the input signal-to-interference ratios. The tests were conducted using ATC specialists as subjects and normal ATC messages as well as modified rhyme test (MRT) words as the test

messages. The interfering signals used were FM and AM signals. The pertinent results are summarized in TABLE 3-6.

TABLE 3-6
RESULTS OF VOICE INTELLIGIBILITY TESTS

<u>Type of Message</u>	<u>Worst Case Input (S/I)_T for 100 % Intelligibility (dB)</u>	
	<u>FM Desired Signal</u>	<u>AM Desired Signal</u>
ATC	9	0
MRT	15	10

The levels shown for the ATC message thresholds are considered appropriate for trained commercial pilots while the MRT message thresholds are applicable to inexperienced pilots who are not necessarily familiar with ATC messages.

Navigation Receivers

The only documentation describing the threshold appropriate to the VOR/ILS receivers was found in Reference 11, which states that an $(S/I)_T$ of 20 dB is required to prevent degradation in these receivers.

DME, TACAN Receivers

Reference 11 states that a signal-to-interference ratio of 8 dB is required to insure satisfactory operation of this type of receiver. However, measurements conducted on a representative airborne TACAN receiver (See Reference 12), indicated that a $(S/I)_T$ of 10 dB is required in the presence of a CW interfering signal and a $(S/I)_T$ of -10 dB is required in the presence of an interfering IFF pulse. During these tests, the TACAN receiver was being operated in an air-to-air mode on 1090 MHz and an IFF reply code of 1311 was used as the interfering signal. No degradation due to this coded reply was observed when the TACAN receiver was operated within the 962-1024 MHz or 1151-1213 MHz frequency ranges.

ATC Transponder Receiver

Measurements reported in Reference 13 indicate that the threshold of degradation to be expected for the ATC transponders used on commercial airlines is 10 dB, if the interfering signal is a CW emission and 0 dB, if the interfering signal is a pulsed emission. Although the measurements were not conducted on the type of transponder installed on the Sabreliner, the similarities in the design of the two units and the interference rejection features of each indicate that the performance of the Sabreliner transponder can be expected to be equivalent to, if not superior to, the performance of the tested transponder in the presence of interference.

Radar Receivers

No information has been found which specifies the degradation thresholds for the receivers employed in the weather radar, the doppler radar, and the altimeter systems. Therefore, a conservative value of 10 dB has been assumed for these analyses.

Receiver Sensitivity, R_S

The sensitivity, or performance threshold, of each receiver to be considered is a required input parameter for the analyses. It can be obtained from the nominal characteristics describing the equipment or from measured data.

SUMMARY

This section has described the model developed to predict potential interference interactions between equipments on an airplane. The prediction model has been developed and automated as an equation relating the expected effective interfering power at the input of a receiver to the effective power which would result in degradation. This approach provides inherent flexibility within the model in that each parameter in the expression can be replaced with a subroutine and individual subroutines can be replaced. Thus, the model is amenable to extension or expansion into a larger model capable of predicting inter-aircraft and aircraft-to-ground environment interactions as well as the intra-aircraft analysis for which it was developed.

The model is not sensitive to a particular airframe or to particular equipment types. The airframe coupling model is valid for all practical airframes. The ability to evaluate the interactions in different types of equipments is inherent due to the requirement that the individual equipment performance models are established external to the prediction model and

used as input parameters. At the present time, these performance models are developed manually and the methods used to accomplish this effort have been described herein. This phase of the problem can also be substantially automated through the development of an equipment synthesis pre-processor.

SECTION 4

PROGRAM UTILIZATION

This section presents information related to the use of the program for interference analysis. The input and output data are described, and a discussion of the procedures followed by the program is presented. Finally, the methods necessary for more refined analyses are explained.

Input Data

The program requires input data on standard 80 column automatic data processing punch cards. The cards are: one general parameter card; two data cards for each transmitter, and two data cards for each receiver. Three card field formats are used to present the data; alpha-numeric characters, integral characters, and floating point decimal characters.

General Parameter Card

The format of the general parameter card is shown in TABLE 4-1.

TABLE 4-1
GENERAL PARAMETER INPUT CARD FORMAT

Columns	Description	Field Format
1-2	Total Number of Transmitters (50 maximum)	Integer
6-7	Total Number of Receivers (50 maximum)	Integer
11-17	Frame Number of Nose Bulkhead	Floating Point
21-27	Radius of Nose Bulkhead in feet	Floating Point

The first two items are self-explanatory. These numbers enable the computer to determine how many possible interactions it must examine before the problem is completed.

The frame number and radius of the bulkhead are used to enable a calculation of the expected knife-edge losses along those paths which traverse the obstruction created by the bulkhead as explained in Section 3.

Transmitter Data Cards

The formats of the two transmitter data cards are shown in TABLE 4-2.

TABLE 4-2
TRANSMITTER DATA CARD FORMATS

Card 1

Columns	Description	Field Format
1-2	Antenna Number	Alpha-Numeric
3-12	Descriptive Code	Alpha-Numeric
14-21	Lower Operating Frequency (MHz)	Floating Point
23-30	Upper Operating Frequency (MHz)	"
32-37	Primary Bandwidth (kHz)	"
39-44	Secondary Bandwidth (kHz)	"
46-49	First Spectrum Slope Falloff (dB/decade)	"
51-54	Second Spectrum Slope Falloff (dB/decade)	"
56-58	Transmitter Power (dBm)	"
60-63	Antenna Gain (dBi)	"
65-67	Modulation Type	Alpha-Numeric
69	Pulse Compression Indicator (C=Chirped, otherwise blank)	"
71-74	Pulsewidth (μ s)	Floating Point
76-79	Pulse Rise Time (μ s)	"

Card 2

1-6	Lower Filter Limit (MHz)	Floating Point
8-13	Upper Filter Limit (MHz)	"
15-20	Frame Number of Antenna	"
22-26	Antenna Height in Feet	"
28-31	Antenna Angle (degrees)	"
33	Raised Antenna Indicator (0=No; 1=Yes)	Integer
35	Number of Harmonics to be Examined (1-9)	Integer
37-40	Suppression Level of Second Harmonic (dB)	Floating Point

TABLE 4-2 (Cont.)

Card 2

Columns	Description	Field Format
42-45	Suppression Level of Third Harmonic (dB)	Floating Point
47-50	Suppression of Fourth Harmonic (dB)	"
52-55	Suppression Level of Fifth Harmonic (dB)	"
57-70	Suppression Level of Sixth Harmonic (dB)	"
62-65	Suppression Level of Seventh Harmonic (dB)	"
67-70	Suppression Level of Eighth Harmonic (dB)	"
72-75	Suppression Level of Ninth Harmonic (dB)	"

The antenna number is used as an identifier for the transmitter and its associated antenna. These two columns are used by the program to identify transmitter-receiver common equipment. It is intended, therefore, that these columns be used as an antenna identifier so that when the program selects the receiver using the same antenna for examination, it realizes that a transceiver is involved and does no calculation for that particular equipment pair. Columns 3-12 can be used as any description code associated with the transmitter. As an illustration, consider the following pair of descriptions:

```
11 UHF XMTR
11 UHF RCVR
```

As is evident, the two descriptions are intended to identify a UHF transceiver connected to antenna number 11. As the program examined transmitter-receiver pairs for possible interactions, it would recognize these descriptions as components of the same system because the characters in the first two columns are identical. The program would, accordingly, skip this calculation. It is important, therefore, that the antenna associated with any transceiver be given the same number to prevent an unfounded determination of potential interference.

The next two items, the lower and upper operating frequencies, are used to describe a transmitter capable of being tuned over a range of operating frequencies. When this situation occurs, the program synthesizes the spectral characteristics of the transmitter and then examines the potential interference from the transmitter over its entire range of operating frequencies. When a specific operating frequency is appropriate, these two fields should be completed identically with the known operating frequency. When more than one specific frequency must be examined, but a continuous tuning range is inappropriate, a separate set of

transmitter data cards should be included for each operating frequency.

The next four items, the bandwidths and slope characteristics, are explained in Section 3, where the primary bandwidth is B_1T , the secondary bandwidth is B_2T , and the first and second slope fall-offs are M_1 and M_2 , respectively. The transmitter power in dBm and the antenna gain in dBi were discussed previously.

The required modulation indicators are the standard designators; A3, F3, P0, P9, etc., and are used to enable the program to calculate the expected peak interfering signal when appropriate. The important designators are the pulse designators as explained in Section 3.

The pulse compression indicator column is left blank unless the transmitter uses frequency modulation during the pulse duration. If the transmitter is chirped, the letter "C" is used in the column.

The pulse characteristics, width and rise time, are self-explanatory.

The lower and upper filter limits are used to truncate the spectral energy of the transmitted emissions. When these values are submitted, the program assumes that the filter has an infinite slope outside the region described by the limits. The primary application for these data is to describe waveguide cut-off phenomena.

The geometric parameters describing the antenna placement on the airframe are used to determine the coupling losses. The frame number, which corresponds to a Z-axis coordinate in inches, and the antenna angle, which corresponds to a φ coordinate in degrees using the upper fuselage centerline as a reference, enable the ray path length and curvature loss factor to be determined.

The antenna height in feet corresponds to the distance of the antenna from the centroidal axis of the airframe. In the case of an antenna which is surface mounted on the fuselage, this parameter represents the radius of the airframe at the corresponding frame number.

The raised antenna indicator is used to identify those antennas which are not surface mounted on the fuselage. For example, the VOR/ILS antennas on the vertical stabilizer are raised antennas. This enables the program to determine the free-space portion of the transmission path between a surface mounted antenna and a raised antenna. In doing so, the model assumes that the airframe is cylindrical with a radius equal to the height of the surface mounted antenna.

The user may select the number of harmonic emissions to be examined during the analysis. If the number 1 is specified, only the fundamental emission spectrum is modeled. If the number is greater than one, then each harmonic is synthesized in a manner identical to the fundamental emission, except that the beginning level is suppressed by the amount specified by the user for each harmonic in the fields designated above.

Receiver Data Cards

The formats of the two receiver data cards are shown in TABLE 4-3.

**TABLE 4-3
RECEIVER DATA CARD FORMATS**

Card 1

Columns	Description	Field Format
1-2	Antenna Number	Alpha-Numeric
3-12	Descriptive Code	Alpha-Numeric
14-21	Lower Operating Frequency (MHz)	Floating Point
23-30	Upper Operating Frequency (MHz)	"
32-37	IF Bandwidth (kHz)	"
39-42	IF Frequency (MHz)	"
44-47	IF Selectivity Slope (dB/decade)	"
49-52	RF Selectivity Slope (dB/decade)	"
54-56	Image Rejection (dB)	"
58-60	Spurious Response Rejection (dB)	"
62-69	Lower Spurious Response Limit (MHz)	"
71-78	Upper Spurious Response Limit (MHz)	"
80	Local Oscillator position (A=above; B=Below)	Alpha-Numeric

Card 2

1-6	Frame number of antenna	Floating Point
8-12	Antenna Height in Feet	"
14-17	Antenna Angle in degrees	"
19	Raised Antenna Indicator (0=No; 1=Yes)	Integer
21-25	Receiver Sensitivity (dBm)	Floating Point
27-30	Antenna Gain (dBi)	"
32-35	Degradation Threshold (S/I) ratio (dB)	"

Many of the items in the receiver card fields are either identical to or analogous to the items contained in the transmitter card fields and, accordingly, need no further explanation. However, a discussion of the treatment of the spurious responses will be given.

The amplitude characteristic of the image response of the receiver is synthesized in a manner identical to the fundamental response characteristic except that the designated image rejection is used to weight this characteristic. The frequency range of consideration for the image response depends on whether the local oscillator injection frequency is higher or lower than the receiver tuned frequency (See Equation 3-19). In some receivers, the injection frequency can be higher or lower, depending on the segment of its operating range in which the receiver is tuned. For example, the intermediate frequency of the TACAN receivers is 63 MHz. The local oscillator injection signal is derived from the associated transmitter signal. When the receiver operates between 962-1024 MHz, the local oscillator frequency lies above the tuned frequency. When the receiver is tuned between 1151 - 1213 MHz, the oscillator frequency lies below the tuned frequency.

When this situation arises, the receiver should be treated as two separate receivers, one for each portion of its operating band.

As mentioned in Section 3, the frequency limits for consideration of spurious responses are specified as discrete frequencies rather than difference frequencies from the receiver tuned frequency. In a simplified first level analysis, these limits should be chosen to encompass the expected range of spurious responses over the entire operating range of the receiver. For a more refined analysis involving specific operating frequencies, only the frequency limits appropriate to those operating frequencies should be specified. Note that the specification of the spurious response frequency limits in terms of discrete frequencies allows these limits to be asymmetrical about the tuned frequency. Examination of Equations (3-20a and 3-20b) shows that the most sensitive spurious responses usually are found at frequencies below the tuned frequency when the local oscillator injection frequency lies below the tuned frequency and are found at frequencies above the tuned frequency when the converse is true. Thus, the specification of the limits of the spurious response frequencies in this manner provides a simple, yet flexible, method for enabling different levels of refinement in the analysis.

Output Formats

The output of the computer program contains a listing of the input data and the result of the analyses. A partial output listing is shown in Figure 4-1. Note that the listing of the input data for the transmitters and receivers is presented in the exact order required on the input cards previously discussed.

The analysis results are presented in terms of equation (3-5). Each of the columns is self-explanatory except for the remarks column, which is discussed below. The first set of listings shown are those transmitter-receiver combinations for which potential interactions are predicted. For each potential interfering transmitter, all of the potential victim receivers are shown with the computed value of each term in the expression.

After all of the potential interactions have been listed, those transmitter-receiver combinations for which no interference is expected are shown with the computed values of the terms in the expression. This listing contains those equipment combinations which require no further examination.

At the end of the list containing the "culled," i.e., eliminated, combinations, a matrix is provided which summarizes the expected transmitter - receiver pairs for which potential interference is predicted. This matrix is provided only as a convenient qualitative quick-reference for the analyst.

The remarks column contains special notations which are relevant to the analyses. Five remarks are possible, as discussed below:

Curvature Range Exceeded

This remark indicates that the portion of the path loss due to the curvature along the path exceeds 100 dB, the upper limit predicted for the curvature factor. When this situation occurs, the model assumes that the curvature factor is 100 dB and proceeds with the computation.

Frequency is Too Low

As explained in Section 3, when the operating frequency is too low, the assumptions used in developing the path loss model may become invalid. When such a situation arises, the program makes no computation and a manual analysis is required. The present lower limit used in the analysis is 30 MHz.

Antennas Are Too Close

When two antennas are too close to enable a calculation of path loss, the program assumes that the loss is 0 dB. It then examines the transmitter receiver pair involved based on the remaining parameters and either retains or eliminates the combination on this basis. An example of this arises with the antenna on the Sabreliner which is shared by a VHF transceiver and the UHF transceiver.

H = 2, 3, 4...9

When the worst case interaction has been determined to be due to a harmonic emission rather than the fundamental emission of a transmitter, the interfering harmonic is noted.

$$L_k = X \text{ dB}$$

This remark indicates that the path between the transmitter-receiver pair being examined involved a knife-edge obstruction due to the nose bulkhead. The amount of additional loss which has been automatically included in the path loss computation is noted for information purposes.

Suggested Operating Procedures

This discussion contains the suggested procedures to be followed during an analysis to enable successive levels of refinement with a minimum of manual computation.

First Level Analysis

The first level analysis is intended to eliminate from further consideration those combinations of equipments which are not expected to result in interactions under any operating conditions. During this phase, the full tuning range of the equipments should be used as input parameters, the specified receiver spurious response limits should encompass all of the potentially susceptible frequencies over the tuning ranges, the minimum spurious response rejection should be used, and the specified degradation threshold should indicate the maximum required S/I ratio for the receiver involved. At the completion of this phase, the equipment combinations satisfying the following conditions will be retained for further attention:

1. Equipments with overlapping or immediately adjacent operating frequency ranges.
2. Equipments with harmonically related operating frequency ranges for which the harmonic attenuation offered by the transmitter is inadequate to preclude interference.

As an illustration of representative results of this level of analysis, a typical problem was solved on the computer for the Sabreliner aircraft. The analysis consisted of evaluating the potential interactions between 11 transmitters and 21 receivers. One reason for the large number of receivers is that each TACAN receiver can operate in one of two split frequency ranges utilizing one of two alternate antennas. Accordingly, the two TACAN receivers required 8 sets of data cards for an adequate description.

With this equipment complement, there were 207 possible interactions to be considered. The first level analysis described above identified 40 potential interactions requiring further examination and eliminated the remaining 167 possible situations. The running time for the computer was 25 seconds.

It should be noted that, since the program does not presently consider the polarization mismatch loss as explained in Section 3, this factor should be included manually at the completion of the automated first level analysis. This may result in additional equipment pairs being eliminated.

Second Level Analysis

The transmitter-receiver pairs retained as potential problems after the first level analysis can be subjected to a more refined study to determine the expected mutual effects. Two approaches to the second level analysis are possible, depending on whether the actual equipment operating frequencies are known.

If the actual operating frequencies are not known, then the second level analysis can provide information relating to required frequency separations which preclude degrading interference interactions. In order to make this type of determination, each transmitter, and the receiver for which it is a potential source, is submitted as a separate problem.

When the input data cards are prepared for the transmitter, they are completed exactly as was done in the first level analyses, except that several combinations of discrete operating frequencies are used. Several sets of cards are prepared for the transmitter, each with a difference in operating frequency equal to the appropriate channel separation. For example, the data cards for the VHF communications transmitters would have operating frequencies separated by 50 kilohertz. The user should be careful to modify the transmitter description (Col. 3 to 12) slightly for each operating frequency so that the output results can be correlated properly.

The input data cards for the potential victim receivers are also modified slightly for the second level analyses. One set of data cards is required for each receiver. In this instance, however, the input discrete operating frequency is specified at either the upper, or lower, frequency within the operating range of the receiver. In addition, the limiting frequencies at which spurious responses are a potential problem are modified to reflect the expected receiver susceptibility to this interference mechanism at the discrete operating frequency specified as an input. If desired, these spurious response limits may be specified to reflect the asymmetry noted previously. If this is done the operating frequency should be specified at the upper

end of the operating-range if the local oscillator operates below the tuned frequency, and vice versa, in order to insure that this type of interaction is given proper consideration.

In other words, each combination of transmitters and receivers retained as potential interference problems by the first level analysis is further evaluated in the second level analysis by sequentially studying the reduction in the expected effects as the difference between the equipment operating frequencies is increased.

This level of analysis can be expected to enable removal from further consideration the interactions expected due to harmonically related equipment operating frequencies and those interactions involving equipments with immediately adjacent operating frequency ranges for which no spurious responses can be expected under worst case conditions. Of course, the required frequency separations resulting from this level of analysis must be respected to preclude these interactions.

If the respective operating frequencies are known, the input data can be submitted to reflect these frequency relationships and the results obtained will reflect this situation also. This raises the immediate question concerning the need for a two-level analysis if the actual operating frequencies are known. The response to the question is that there is, in fact, no need for the first level analysis if the operating frequencies are known, provided, of course, that these frequencies will never be changed.

The first level analysis will eliminate from further consideration, including future considerations, those equipment combinations for which interactions are not expected under any possible assignment of operating frequencies. The generalized second level analysis will provide frequency assignment guidelines which will preclude undesirable interactions under any assignment of frequencies provided the guidelines are met.

The particular analysis based on specific operating frequencies provides results which may be applicable only to the set of operating frequencies submitted at the time.

Thus, it is recommended that specific operating frequencies be submitted on inputs only after two levels of generalized analysis have been accomplished and generalized conclusions have resulted.

Third Level Analysis

The equipment combinations expected to be retained as potential interference problems after the second level analysis are those sharing the same or immediately adjacent operating

frequency ranges for which the path loss is inadequate to preclude spurious response interference interactions with an acceptable or realizable separation in the equipment tuned frequencies.

Other non-linear effects, such as cross modulation, desensitization, and intermodulation must also be considered during this level of analysis. The latter non-linear effects can be omitted from the first two levels of effort since they do not arise between avionics equipments operating in widely separated frequency bands.

Because of the detailed nature of the analysis required for responsible conclusions pertaining to non-linear effects, the third level of analyses is necessarily accomplished manually. In performing this type of study, due consideration must be given to the receiver detection process and nature of the potential interfering signal in order that the degradation threshold may be adjusted along with the frequency relationships discussed previously.

If examination of potential interactions due to receiver spurious responses is required, the receiver must be modeled to reflect each individual response for which the path loss is inadequate to preclude a degrading interaction. This modeling is accomplished by rearranging equation (3-5) to provide for a solution of the frequency rejection term, L_f required to preclude degradation, and then determining the appropriate value of spurious response rejection, K_s , using the procedures set forth in SECTION 3. In this instance, L_f and K_s are identical factors.

The expected occurrence of degradation due to cross modulation and desensitization can be estimated by assuming that the receiver input on-tune susceptibility for this phenomenon is -20 dBm. The effective rejection of the receiver to this phenomenon is determined by calculating the selectivity characteristic of the first RF amplifier. This characteristic can be calculated using the methods described in SECTION 3, but it must be emphasized that only the tuned circuits associated with the input and output of the first RF amplifier should be used in determining this selectivity characteristic.

Interference due to intermodulation can be ignored on most airplanes. Degradation in avionics equipment due to this phenomenon requires the simultaneous operation of at least two transmitters and one receiver in the same operating frequency range.

Additional Applications

The model presented herein can be used to determine the expected effects of future equipment installations as well as the effects of existing complements on any airframe. This is

accomplished by the following sequence:

1. Prepare input data cards describing the proposed equipment using the most operationally desirable location on the airframe to determine the required geometrical parameters.
2. Perform two levels of analysis as discussed herein.
3. If necessary, perform a third level analysis to determine the maximum frequency rejection that can be expected between the potentially troublesome equipment combinations.
4. Solve equation (3-5), using this maximum frequency rejection, to determine the path loss required for compatible operations.
5. Perform an analysis using the optimum frequency dependent input parameters as constants and varying the proposed location to determine the expected path losses.
6. Decide on the operational practicality and suitability of the proposed system when the maximum expected path loss is determined.

SECTION 5

SABRELINER EMC EVALUATION

Introduction

The entire avionics complement on the Sabreliner was subjected to three levels of analysis as described in SECTION 4 of this report. In addition to the existing equipments, a proposed VHF SATCOM terminal was evaluated, although the evaluation of this installation was not made until the third level of analysis.

First Level Analysis Results

The input data used for the first level analysis are shown in APPENDIX V. The results of this analysis are shown in the form of a matrix in TABLE 5-1. Those equipment combinations denoted by an "X" in this table were retained as potential interference problems. The combinations denoted by a blank space were eliminated from further consideration. Each of the equipments involved may be identified by referring to Figure 3-1 and TABLE 3-2.

TABLE 5-1
FIRST LEVEL ANALYSIS RESULTS

Transmitter Antenna No.	1	2	3	4	5	6	7	8	9	10	11	12	13	14	15
1. Weather Radar															
3. TACAN-2				X			X					X			
4. ATC			X		X		X					X			
5. TACAN-2				X			X					X			
6. VHF Comm.						X		X					X	X	X
6. UHF Comm.		X													
7. TACAN-1			X	X	X										
8. VHF Comm.						X							X	X	X
9. Doppler															
11. Altimeter															
12. TACAN-1			X	X	X										

Second Level Analysis Results

A second level analysis was performed as described in SECTION 4. Because of the relatively

small size of the Sabreliner, and the concomitantly small coupling losses, the only equipment combinations eliminated were the VHF communications transmitters and the UHF communications and UHF direction finding receivers. These equipments were eliminated as interference situations as soon as the harmonic relationship between the respective operating frequencies no longer existed. The equipment combinations remaining after this level of analysis were:

1. TACAN versus the ATC transponder.
2. TACAN transmitters versus the TACAN receivers.
3. VHF Communications Transmitters versus VHF Communications receivers.
4. VHF Communications Transmitters versus VHF navigation receivers.
5. The UHF Communications Transmitter versus the Glide Slope receivers.

Third Level Analysis Results

Each of the Sabreliner equipment combinations retained after the second level analysis was subjected to a detailed manual analysis to establish the frequency separations required to preclude degrading interference. In addition, the expected mutual effects due to the installation of a VHF Satellite Communications (SATCOM) terminal were determined during this phase of the study. These predictions are based on nominal equipment characteristics as published by the manufacturers involved rather than measured characteristics obtained from an adequate sampling of the equipment. Because of this, some variation from the predicted results can be expected during actual operations. Further, operational considerations have not, in general, been considered. Such considerations could affect the frequency of observation of the predicted effects.

TACAN Transmitter Effects on the ATC Transponder

The TACAN transmitted pulses will not result in degrading interference to the ATC Transponder receiver because blanking pulses are provided by the TACAN equipment which disable the transponder for the period of each TACAN transmission. If this were not the case, serious effects could be expected, since the input interfering signals from the TACAN, which can reach a peak level as high as 32 dBm, might result in damage to the input circuitry of the transponder receiver as well as interference due to spurious responses and adjacent channel effects. Further, interference due to TACAN interpulse CW is not expected, since the TACAN local oscillator signal is prevented from reaching the transmitter power amplifiers by a diode switching circuit.

ATC Transponder Effects on the TACAN Receiver

The TACAN receivers have a Yttrium Iron Garnet (YIG) input filter which limits all

input signals to a maximum level of 10 dBm, thereby precluding any high power interference effects in these receivers. However, the determination of the interactions which are to be expected between these equipments is beyond the scope of this study, for the following reasons:

1. Each TACAN receiver operates in conjunction with two antennas. The antennas are alternately switched into the receiving system to insure that the best quality signal is obtained. Thus, the effect of an interfering signal impinging on the antennas depends on which antenna is in use and the time relationships between the interfering signal, the desired signal, and the antenna switching doctrine.

2. The detection circuitry in the TACAN receivers is such that when a pulsed signal is received and recognized, a timing circuit is enabled, which counts for twelve microseconds, nominally. At the end of this period of time, a gate is enabled. If a second pulsed signal is recognized during the interval in which the gate is enabled, an output is provided; otherwise, the receiver ignores the first pulse and no output results. Thus, the effect of a pulsed interfering signal on the TACAN receiver depends on the interpulse spacing of the interference, and the time relationship between reception of the interfering pulses and the desired TACAN pulses.

3. The ATC Transponder emissions consist of a coded train of pulses. A total of 4096 different codes is possible, of which 64 selected codes are presently used. The spectral characteristics of the emissions, and the resulting effects on the TACAN receivers will change as different codes are used. For example, if a 7777 or a 7700 transponder code is used, the pulse train duty cycle will be 0.5 and 0.25, respectively. Under these conditions, the TACAN receiver will achieve a steady state response during the pulse train and no second pulse will be detected during the gate interval. If a 1311 or 0100 code is used, an interval of approximately 12 microseconds will exist between certain of the pulses in the train and an erroneous output is possible, depending on the time relationships between the interfering pulse train and the reception time of the desired TACAN pulses.

4. Each individual ATC Transponder pulse has a duration of 0.45 microseconds, a rise time between 50 and 100 nanoseconds, and a fall time between 50 and 200 nanoseconds. Although 50 nanosecond rise and fall times represent the design goals and the expected capabilities of the equipment, the maintenance procedures provide for go-no go acceptance criteria of 100 nanoseconds and 200 nanoseconds for the rise and fall times, respectively. Further, it should be noted that in spite of the generation of the pulses in the modulator as trapezoidal pulses, the output of the transmitter RF stage is taken from a cavity resonator, which will tend to shape the output pulses. It can be shown that the spectral characteristics of the output pulses change sufficiently as these parameters are varied to enable either a conclusion that interference to TACAN could result, if the appropriate codes were used at all possible frequency separations, or a conclusion that no interference would result at the

minimum separation (approximately 60 MHz) under any of the possible codes.

Accordingly, an extensive, statistical effort would be required to make estimates of the expected effects of the Transponder on the TACAN receivers. Since such a study was not a goal of this effort, it will suffice to state qualitatively that degradation to the TACAN receivers as a result of the transponder emissions is possible but not probable.

Mutual Effects Between TACAN Systems

The expected mutual effects between the TACAN systems on the Sabreliner are nearly as difficult to determine as the effects due to the ATC Transponder, because of the technique employed to switch the antennas associated with each equipment. One significant difference to be considered, however, is that the TACAN transmitters emit a signal which will always satisfy the TACAN detection criteria. Therefore, a worst case determination was possible and it was found that degrading interference could result due to the sideband energy of one system transmitter occurring within the IF passband of the second systems receiver, unless the separation in the respective tuned frequencies is greater than 9 MHz. Further, interference may also result when the transmitting frequency of one TACAN system falls on the image frequency of the other system receiver. The image frequency of a TACAN receiver is located 126 MHz above or below the receiver tuned frequency, depending on whether the receiver is operating in the lower or upper portions, respectively, of its overall tuning range. If the output pulses of the transmitters were synchronized in time, no degradation would ever occur since the receiver would not be operative when the impinging undesired signals arrived.

Mutual Interactions Between the VHF Communications Equipments

The communications receivers were modeled as previously described and the expected effects due to the transmitters were determined. Mutual interference between the VHF systems can be expected if the frequency separation between the systems is less than 1.8 MHz.

The interference will be caused by the spectral energy contained in the noise sidebands of the transmitter which fall within the receiver passband. The degradation threshold used to evaluate this effect was 10 dB. This threshold was used because the interference signal will appear as noise to the receiver. The emission characteristics of the transmitter were modeled in the manner described in SECTION 3.

VHF Communications Transmitter Effects in the VHF Navigation Receivers

The noise sidebands of the VHF communications transmitters will result in degrading

interference to the VOR/ILS receivers if the frequency separation between these equipments is less than 0.3 MHz. The interaction will arise in the same manner described above. Since the interfering signal appears as noise to the receiver, a degradation threshold of 10 dB was used.

Effects of the UHF Transmitter on the Glide Slope Receivers

The emissions from the UHF communications transmitter can result in degrading interference to the Glide Slope receivers by exciting a spurious response in the receiver, and by exciting a response within the receiver passband due to the transmitter noise sidebands. The spurious responses which could arise include the receiver image response and the response which arises when the frequency separation is one-half of the intermediate frequency ($p = q = 2$ in equation 3-20b). These potential spurious interference situations can be precluded by insuring that the UHF transmitter is not tuned 102.4 MHz \pm 60 kHz, or 25.6 MHz \pm 50 kHz below the tuned frequency of the Glide Slope receiver. Degrading interference due to the noise sidebands of the transmitter can be avoided if the separation between the tuned frequencies of the equipments is 0.6 MHz or greater.

Expected Effects of Future VHF SATCOM Terminal

Since the detailed characteristics of the equipment to be used for future voice communications using a satellite are not fully known, certain assumptions had to be made to enable an evaluation of the impact of such a terminal. These are:

1. The SATCOM receiver characteristics were assumed to be identical to those of the existing Sabreliner VHF communications receivers, except that the sensitivity has been increased to -111 dBm, rather than -97 dBm, in accordance with ARINC characteristic 566.
2. The SATCOM transmitter terminal was assumed to have identical characteristics compared to the existing VHF transmitters, except that the output power will be 500 watts.
3. The SATCOM antenna will be circularly polarized with 0 dBi gain as set forth in ARINC Characteristic 566 and will be located on the top centerline of the Sabreliner fuselage approximately at Frame Number 135.
4. The VHF SATCOM terminal will never be used simultaneously with the existing VHF communications system whose antenna is installed on the top centerline at Frame Number 168 i.e., the use of both of these systems is assumed to be mutually exclusive.

Based on these assumptions, it was found that the proposed SATCOM Terminal would result in degrading interference to the VHF navigation receivers and in mutual interference with the VHF communications system located on the bottom centerline at Frame Number

135. In each instance the interference effects will result from the noise sidebands of the transmitters involved. Degradation in the VHF navigation receivers can be avoided if the SATCOM transmitter frequency is separated by at least 15 MHz from the receiver tuned frequencies, i.e., no degradation will result if the SATCOM frequency is above 133 MHz.

Mutual interference between the VHF communications systems can be precluded if the frequency separation between the respective tuned frequencies is at least 4.2 MHz. It should be noted that this restriction is applicable in both directions. The existing VHF communications transceiver has a transmitter output power of 25 watts and a receiver sensitivity of -97 dBm. The proposed SATCOM equipment has a transmitter power of 500 watts and a receiver sensitivity of -111 dBm. Thus, the difference in transmitter powers of 13 dB virtually offsets the difference in receiver sensitivities (14 dB) for interference calculations.

No other interference is expected provided that harmonic relationships between the operating frequencies of the SATCOM system and the remaining receiving systems on board are avoided when making frequency assignments.

SECTION 6

MODEL EXPANSION POSSIBILITIES

General

As stated previously, the development of the prediction model in the form of an expression has resulted in an inherent modular characteristic which is amenable to expansion and modification. This section will provide a discussion of possible improvements and the methods viewed as providing promise toward realization of a full prediction model.

Antenna Gain Calculator

First, it was mentioned in SECTION 3 that an antenna gain subroutine could be developed which would calculate the gain expected from any antenna on the aircraft. This parameter is currently obtained from manufacturers information or, in the case of aperture antennas, modeled theoretically using manual techniques. Both of these methods could be accomplished by automating the expressions used by an engineer to provide the input data required herein. In addition, the required information could be converted into a statistical parameter by obtaining sufficient information to confidently predict the expected variations in antenna characteristics due to different manufacturers, different antenna types, different aperture sizes and different scanning principles, as appropriate, between antennas performing the same functional mission. A probabilistic representation of antenna gains would also be more meaningful for considerations involving aircraft-to-aircraft or aircraft-to-ground environment problems where perturbations in antenna gain could be expected due to irregularities in airframe geometry, and scanning principles versus aircraft or ground equipment orientation and location.

Improvement In Coupling Loss Predictions

A second area of possible expansion involves improvement of the path loss prediction to include the expected range of errors involved in the theoretical calculations. As mentioned in SECTION 3, the errors experienced between previous predictions and actual observations can be expressed statistically. Further, it is suggested herein that the coupling losses predicted between Sabreliner equipments be verified and reported to the ECAC. When this has been accomplished, the observed variations should be used to improve the prediction model using statistical techniques.

Input Preprocessor

As indicated in SECTION 3, the model can also be expanded and improved by development of an automatic pre-processor which will minimize the number of required input data as well as the effort required to obtain them. This approach will be mandatory if the model is expanded to enable consideration of an aircraft-to-ground environment prediction process. The most extensive environmental data base known to exist in the world is maintained by the ECAC, but the format of these files is not immediately amenable to a realistic solution of this type of problem without a buffering pre-processor as contemplated herein. This pre-processor could also be developed to reflect expected variations in statistical terms, although the time required to describe the ground equipments in this manner would be substantial.

Statistical Prediction Model

The remaining parameters shown in Equation (3-5), which are largely input parameters describing equipment performance, could be expressed statistically by determining the variations expected among equipments used for the same functions on different airframes as supplied by different manufacturers. The development of such a variational representation would require interchanges of information between the developer and airframe manufacturers, airline users, equipment manufacturers, and the military services, or an agency familiar with military equipment installation, performance, and operation, such as ECAC.

Suggested Improvement Sequence

A sequential improvement and expansion program is suggested herein. Certain of the steps could be accomplished simultaneously. The steps indicated follow a sequence which is convenient, without regard to operational necessities. They are:

1. Develop an input pre-processor for the existing model using deterministic expressions, which will minimize the number of required input parameters.
2. Develop an antenna gain subroutine which includes a calculation of expected gain and polarization mismatches, and results in an effective mutual gain calculation between antennas on an airframe.
3. Expand the coupling loss subroutine to reflect the distribution of expected errors, including the errors previously observed as well as those observed by FAA when verifying the predictions reported herein.
4. Expand this overall model to incorporate different coupling loss models and expand the prediction capability to enable estimates of interactions in an aircraft-to-environment (both airborne and ground) situation.
5. Convert the prediction techniques to enable calculations in probabilistic terms.

APPENDIX I
COUPLING LOSS SUBROUTINE

This Appendix contains the flow diagram and program listing for the subroutine used to compute the expected path loss between two antennas on an airframe. The flow chart is shown in Figure I-1. The program listing, which is written in the FORTRAN V language, is shown in Figure I-2.

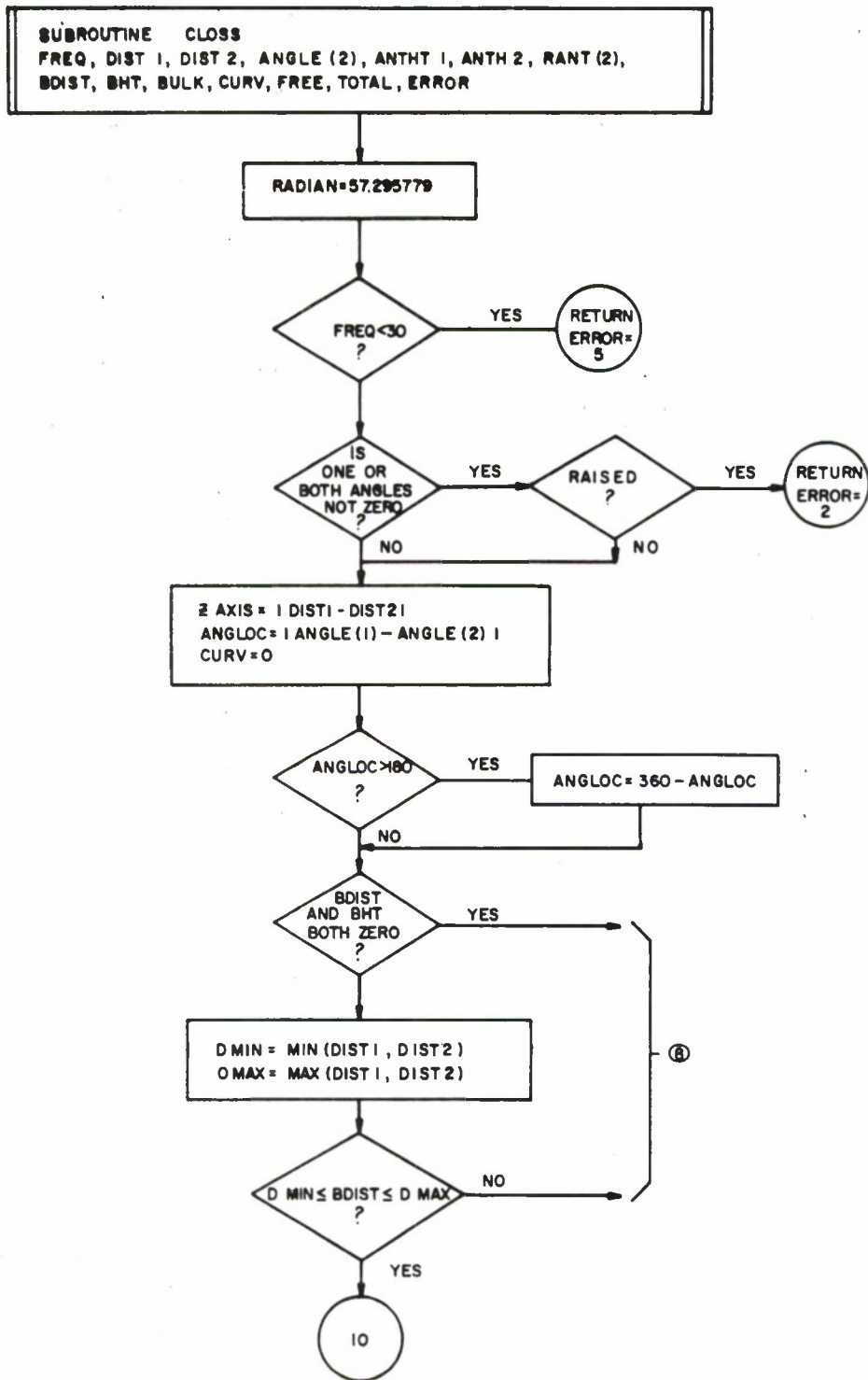

Figure I-1. Coupling Loss Subroutine Flow Diagram.

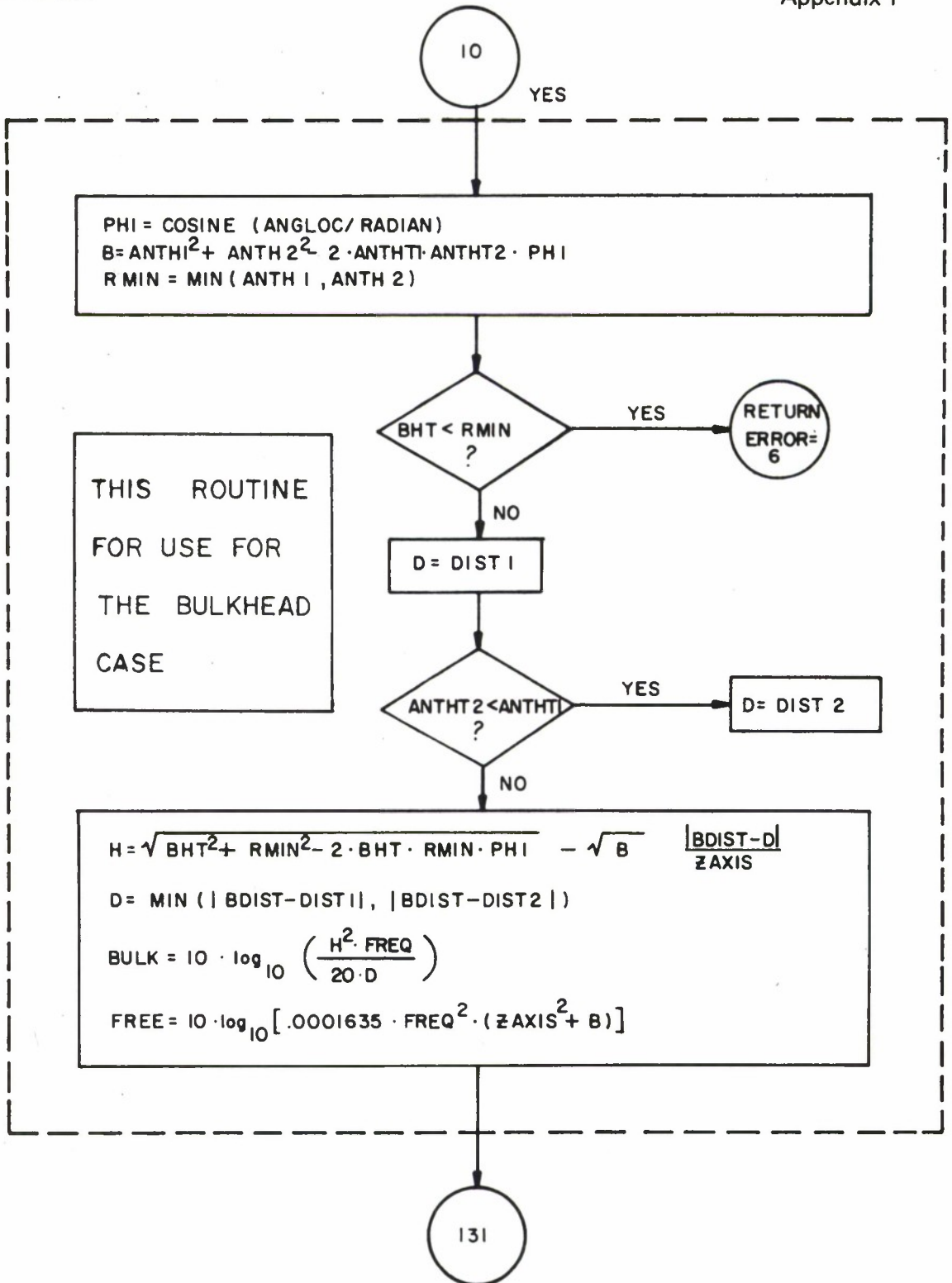

Figure I-1. (Continued)

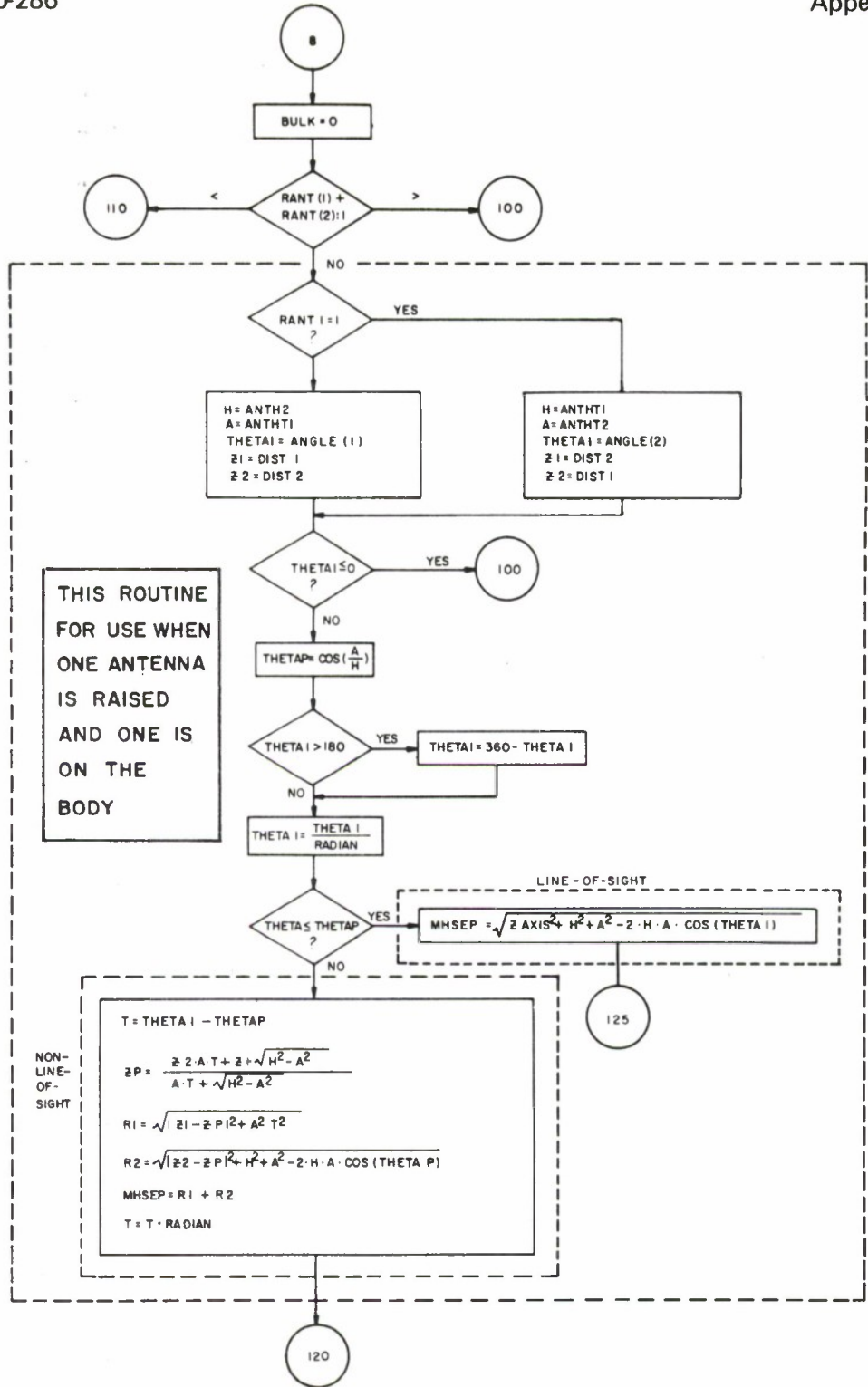

Figure I-1. (Continued)

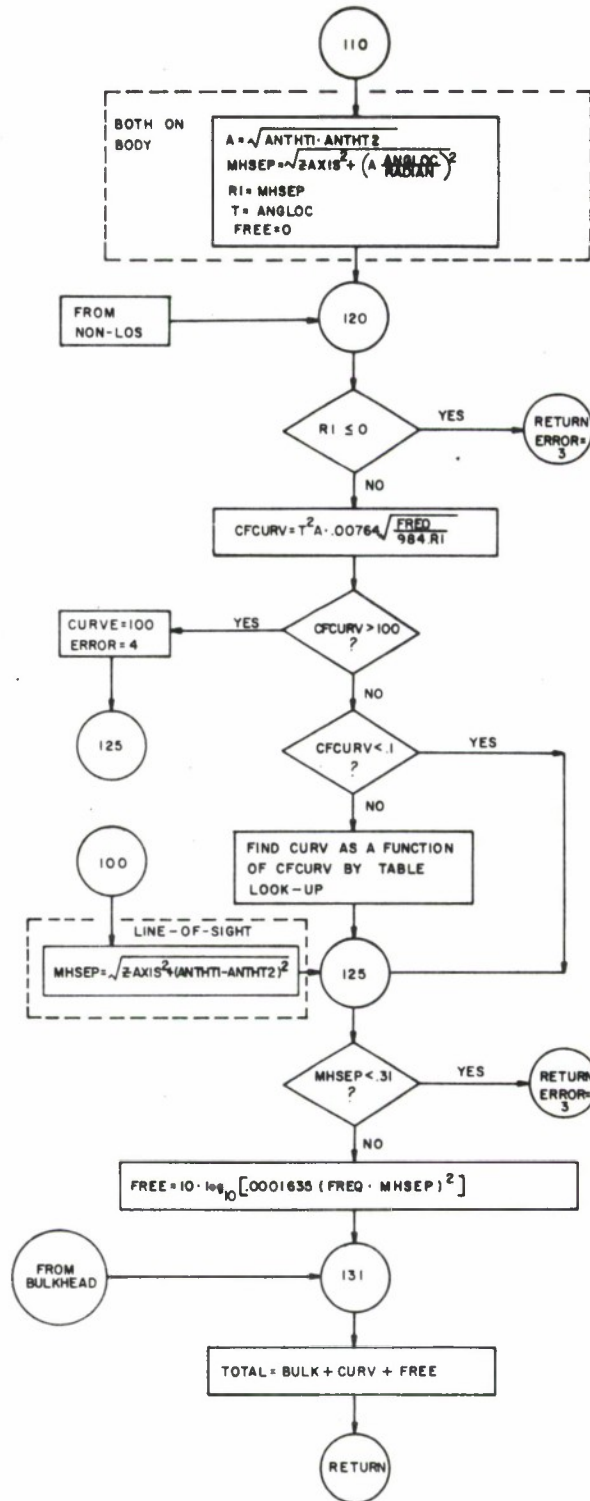

Figure I-1. (Continued)

```

SUBROUTINE CLOSS      ENTRY POINT 001001
STORAGE USED (BLOCK, NAME, LENGTH)
0001 *CODE      001010
0000 *DATA      000147
0002 *BLANK     000000
0003 CLCOMM    000020
    
```

```

EXTERNAL REFERENCES (BLOCK, NAME)
0004 INTRUP
0005 COS
0006 SORT
0007 ALOG10
0010 ACOS
0011 NERR63
0012 NERR33
    
```

```

STORAGE ASSIGNMENT FOR VARIABLES (BLOCK, TYPE, RELATIVE LOCATION, NAME)
0001 000520 100L      0001 000534 110L      0001 000561 120L
0001 000631 127L      0001 000656 129L      0001 000745 131L
0001 000750 140L      0001 000755 150L      0001 000760 152L
0001 000050 20L       0001 000610 2636      0001 000054 30L
0001 000276 8L        0001 000410 80L        0000 K 000063 A
0003 R 000005 ANTH1   0003 R 000000 ANTH2   0000 K 000057 B
0003 R 000013 BULK   0000 R 000070 C        0000 K 000075 CFURV
0000 R 000061 D      0003 K 000004 DIST1   0003 K 000002 DIST2
0003 I 000017 ENR     0003 K 000015 FREE    0003 K 000000 FREQ
0000 000123 INJPS    0000 I 000050 IS      0000 K 000000 MHSEP
0000 R 000024 PM     0000 R 000004 RADIAN  0003 I 000007 KANT
0000 K 000074 K2     0000 K 000070 T      0000 K 000067 THETAP
0000 R 000077 XA     0000 R 000100 XB     0000 K 000101 XC
0000 R 000071 ZP     0000 K 000065 Z1     0000 K 000066 Z2
    
```

```

00101 1*      SUBROUTINE CLOSS
00103 2*      COMMON/CLCOMM/FREQ,DIST1,ANGLE12,ANTHT1,ANTHT2,PANT12,
00103 3*      BUIST,BHT,BULK,CURV,FREE,TOTAL,ERR
00104 4*      INTEGER RANT,ERR
00105 5*      REAL MHSEP
00106 6*      DIMENSION Y(19),PM(19)
00107 7*      DATA RADIAN/57.295779/
    
```

```

0001 000721 125L
0001 000745 131L
0001 000760 152L
0001 000323 50L
0003 K 000003 ANGLE
0003 K 000011 BUIST
0003 K 000014 CURV
0000 K 000054 DMAX
0000 I 000051 I
0000 R 000056 PM1
0000 R 000073 K1
0003 R 000016 TOTAL
0000 R 000052 ZRANIS
    
```

```

0001 000721 125L
0001 000745 131L
0001 000760 152L
0001 000323 50L
0003 K 000003 ANGLE
0003 K 000011 BUIST
0003 K 000014 CURV
0000 K 000054 DMAX
0000 I 000051 I
0000 R 000056 PM1
0000 R 000073 K1
0003 R 000016 TOTAL
0000 R 000052 ZRANIS
    
```

```

0001 000561 120L
0001 000656 129L
0001 000760 152L
0001 000054 30L
0000 K 000063 A
0000 K 000057 B
0000 K 000075 CFURV
0003 K 000002 DIST2
0003 K 000000 FREQ
0000 K 000000 MHSEP
0003 I 000007 KANT
0000 K 000067 THETAP
0000 K 000101 XC
0000 K 000066 Z2
    
```

```

SUBROUTINE CLOSS
COMMON/CLCOMM/FREQ,DIST1,ANGLE12,ANTHT1,ANTHT2,PANT12,
BUIST,BHT,BULK,CURV,FREE,TOTAL,ERR
INTEGER RANT,ERR
REAL MHSEP
DIMENSION Y(19),PM(19)
DATA RADIAN/57.295779/
    
```

Figure I-2. Coupling Loss Subroutine Listing. (page I of 4)

```

00111      8*      DATA          Y / .1,.2, .3,.5,.7,1., 2.,3.,5., 7.,10.,15.,
00111      9*      120., 25., 30., 40., 45.,50., 100. /
00113     10*      DATA PM          / .2,.4,.6, 1.,1.3, 1.4,3.9,5.7,9.4,12.9,17.5,
00113     11*      125.5,32.3,39.,45.,57., 62.5,67.5,100. /
00115     12*      FUNCT(W)=10.*ALOG10(.0001635*W)
00116     13*      CALL INTRUP(0)
00117     14*      BULK=0.
00120     15*      CURV=0.
00121     16*      FREE=0.
00122     17*      TOTAL=0.
00123     18*      IF (FREQ.LT.30.)60 TO 152
00125     19*      LMK=1
00126     20*      DO 30 I=1,2
00131     21*      ANGLE(I)=AMOD(ANGLE(I)+360.)
00132     22*      IF (ANGLE(I))10,30,20
00135     23*      10 ANGLE(I)=ANGLE(I)+360.
00136     24*      20 IF (RANT(I).EQ.1)60 TO 130
00140     25*      30 CONTINUE
00142     26*      ZAXIS=ABS(DIST1-DIST2)
00143     27*      ANGLC=ABS(ANGLE(1)-ANGLE(2))
00144     28*      IF (ANGLC.GT.180)ANGLC=360.-ANGLC
00146     29*      IF (BDIST*BHT)8,8
00151     30*      DMIN=AMIN1(DIST1,DIST2)
00152     31*      DMAX=AMAX1(DIST1,DIST2)
00153     32*      IF (BDIST.LT.DMIN)GO TO 8
00155     33*      IF (BDIST.GT.DMAX)GO TO 8
00155     34*      C
00155     35*      C** BULKHEAD CASE
00155     36*      C
00157     37*      PHI=COS(ANGLC/RAOIAN)
00160     38*      B=ANTHT1**2+ANTHT2**2-2.*ANTHT1*ANTHT2*PHI
00161     39*      RMIN=AMIN1(ANTHT1,ANTHT2)
00162     40*      IF (BHT*RMIN)154
00165     41*      U=DIST1
00166     42*      IF (ANTHT2.LT.ANTHT1)U=DIST2
00170     43*      H=SQRT(BHT**2+RMIN**2-2.*BHT*RMIN*PHI)
00170     44*      H=SQRT(B)*ABS((BDIST-U)/ZAXIS)
00171     45*      U=AMIN1(ABS(BDIST-DIST1),ABS(BDIST-DIST2))
00172     46*      BULK=10.*ALOG10(H*H*FREQ/2U./D)
00173     47*      IF (BULK.LT.6)BULK=6.
00175     48*      FREE=FUNCT(FREQ**2*(ZAXIS**2+B))
00176     49*      GO TO 131
00176     50*      C
00176     51*      C** NO BULKHEAD INTERFERES
00176     52*      C
00177     53*      B IF (RANT(1)*RANT(2)-1)/110,40,100
00177     54*      C
00177     55*      C** ONE ANTENNA RAISED, ONE ON AIRFRAME.
00177     56*      C
00202     57*      40 IF (RANT(1).EQ.1)60 TO 50
00204     58*      H=ANTHT2
00205     59*      A=ANTHT1
00206     60*      THETA1=ANGLE(1)
00207     61*      Z1=DIST1
00210     62*      Z2=DIST2

```

Figure I-2. Continued.

```

00241 63*      60 TO 55
00242 64*      50 M=ANTHT1
00243 65*      A=ANTHT2
00244 66*      THETA1=ANGLE(2)
00245 67*      Z1=DIST2
00246 68*      Z2=DIST1
00247 69*      55 IF (THETA1)100,100,60
00248 70*      60 THETAP=ACOS(A/H)
00249 71*      IF (THETA1.GT.180.)THETA1=360.-THETA1
00250 72*      THETA1=THETA1/RADIAN
00251 73*      IF (THETA1-THETAP)70, /0,80
00252 74*      C
00253 75*      C**  LINE-OF-SIGHT FROM RAISED ANTENNA TO ONE ON BODY.  COMPUTE DISTANCE.
00254 76*      C
00255 77*      /0 MHSEP=SQRT(ZAXIS**2+H*H-2.*H*A*COS(THETA1)+A*A)
00256 78*      60 TO 125
00257 79*      C
00258 80*      C**  COMPUTE TOTAL DISTANCE FOR NON-LINE-OF-SIGHT CASE.
00259 81*      C
00260 82*      80 T=THETA1-THETAP
00261 83*      ZP=(Z2*A*T+Z1*SQRT(H*H-A*A))/(A*T+SQRT(H*H-A*A))
00262 84*      P=ABS(Z1-ZP)
00263 85*      R1=SQRT(P*P+(A*T)**2)
00264 86*      P=ABS(Z2-ZP)
00265 87*      R2=SQRT(P*P+H*H-2.*H*A*COS(THETAP)+A*A)
00266 88*      MHSEP=R1+R2
00267 89*      T=T/RADIAN
00268 90*      60 TO 120
00269 91*      C
00270 92*      C**  LINE-OF SIGHT (ANGLE ZERO)
00271 93*      C
00272 94*      100 MHSEP=SQRT(ZAXIS**2+(ANTHT1-ANTHT2)**2)
00273 95*      60 TO 125
00274 96*      C
00275 97*      C**  BOTH ON BODY. COMPUTE SEPARATION DISTANCE.
00276 98*      C
00277 99*      110 A=SQRT(ANTHT1*ANTHT2)
00278 100*      MHSEP=SQRT(ZAXIS**2+(A*ANGLOC/RADIAN)**2)
00279 101*      R1=MHSEP
00280 102*      T=ANGLOC
00281 103*      120 IF (R1)140,140,122
00282 104*      C
00283 105*      C**  COMPUTE CURVATURE FACTOR AROUND BODY AND FIND LOSS.
00284 106*      C
00285 107*      122 CFCURV=T*T*A*.000764*SQRT(FREQ/984./R1)
00286 108*      IF (CFCURV.GT.100.)60 TO 150
00287 109*      IF (CFCURV.LT..1)60 TO 125
00288 110*      DO 126 I=2,19
00289 111*      126 IF (CFCURV.LT.Y(I))60 TO 127
00290 112*      RETURN 0
00291 113*      127 IF (I.EQ.2)60 TO 129
00292 114*      IF (I.EQ.19)60 TO 128
00293 115*      IF (Y(I)-Y(I-1)-2.*(CFCURV-Y(I-1)))129,129,128
00294 116*      128 I=I-1
00295 117*      129 U=T(I+1)-Y(I)

```

Figure I-2. Continued.

```

00302 118*      BY(I)-Y(I-1)
00303 119*      CY(I+1)-Y(I-1)
00304 120*      XA=Y(I+1)-CFCURV
00305 121*      XB=Y(I)-CFCURV
00306 122*      XC=Y(I-1)-CFCURV
00307 123*      CURV =PM(I-1)*XB*XA/L/B-PM(I)*XA/D*XC/B+PM(I+1)*XB*XC/D/C
00310 124*      125 IF (MHSEP.LT.31760 TU 140
00312 125*      FREE=FUNCT((FHLE*MHSEP)**2)
00313 126*      131 TOTAL=BULK*CURV+FREE
00314 127*      130 ERR=2
00315 128*      60 TO 160
00316 129*      140 ERR=3
00317 130*      60 TO 160
00320 131*      150 ERR=4
00321 132*      CURVE=100.
00322 133*      60 TO 125
00323 134*      152 ERR=5
00324 135*      60 TO 160
00325 136*      154 ERR=6
00326 137*      160 RETURN
00327 138*      END
00330 139*

```

Figure I-2. Continued

APPENDIX II

COUPLING LOSS MEASUREMENT PROCEDURES

This Appendix contains generalized test procedures which are applicable for the validation of the coupling losses indicated in this report (See Figure 3-3, SECTION 3). Two measurement methods are described, a directly indicating technique for the coupling losses at frequencies below 1000 MHz, and a signal substitution technique for measuring the coupling losses at frequencies above 1000 MHz.

Direct Measurement Technique

The test equipment configuration to be used for the coupling loss measurement at frequencies below 1000 MHz is shown in Figure II-1.

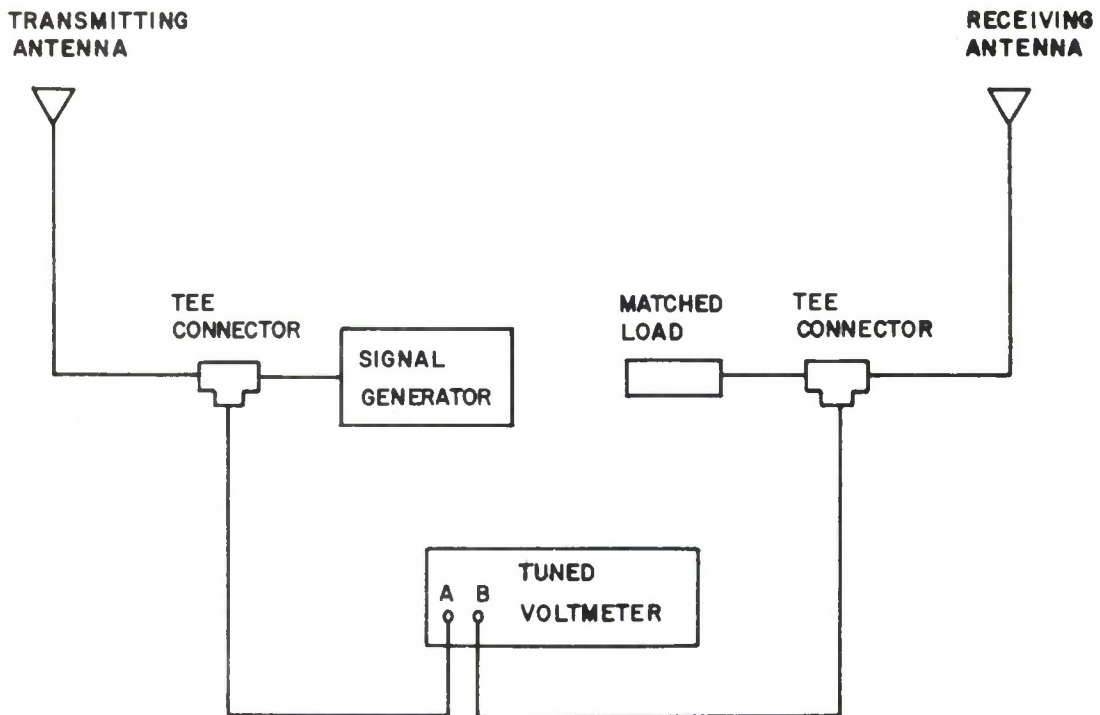

Figure II-1. Equipment Configuration for Measurements Below 1000 MHz.

The types of equipments recommended for use are:

	Frequency Range	Type
Signal Generators	10-480 MHz 800-1000 MHz	HP-608E, or equivalent HP-8614A, or equivalent
Tuned Voltmeter	1-1000 MHz	HP-8405A, Vector Voltmeter, or equivalent
Tee Connectors	1-1000 MHz	HP-11570A, Accessory
Matched Load	1-1000 MHz	Kit, or equivalent

If these equipments are operated in accordance with the manufacturers instructions and in the illustrated configuration, the following parameters can be read directly.

1. The voltage applied to the transmitting antenna. (Channel A).
2. The voltage applied across the matched load of the receiving antenna. (Channel B).

The observed coupling loss is then:

$$\text{Coupling loss (dB)} = 20 \log \text{Channel A voltage/Channel B voltage}$$

In performing the measurements, the following procedures should be followed for each transmitting/receiving antenna combination being considered:

1. Disconnect transmission lines associated with the transmitting and receiving equipments under consideration at the input to the respective equipment.
2. Connect the transmitting and receiving transmission lines to the proper tee connectors as shown in Figure II-1.
3. Tune the signal generator to a convenient frequency within the operating range of the transmitter.
4. Tune the voltmeter to the same operating frequency as that of the signal generator.
5. Record the output voltage level of the generator as indicated with the voltmeter selector switch on Channel A.
6. Record the received voltage level as indicated with the voltmeter selector switch on Channel B.

7. Repeat the measurement four additional times at different frequencies within the operating range of transmitter.

8. Reverse the antenna connections and perform the measurement five additional times on the same operating frequencies previously used.

This procedure should be followed until the coupling losses have been determined between each transmitting antenna which normally operates below 1000 MHz and all of the remaining antennas on the Sabreliner.

Signal Substitution Method

The test equipment configuration to be used for measuring the coupling losses at frequencies above 1000 MHz is shown in Figure II-2.

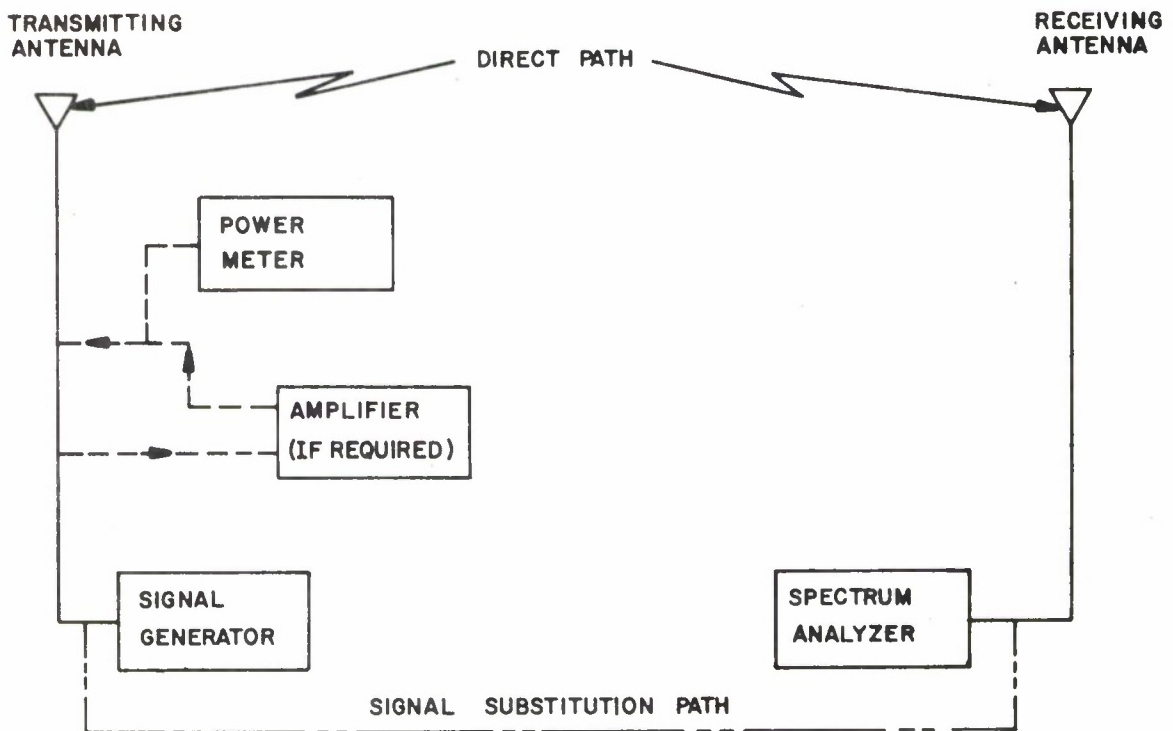

Figure II-2. Equipment Configuration for Measurements Above 1000 MHz.

The types of equipments recommended for use are:

Frequency Range	Type
Signal Generators	
800-2400 MHz	HP-8614A, or equivalent
1800-4500 MHz	HP-8616A, or equivalent
7-11 GHz	HP-620B, or equivalent
Spectrum Analyzer	
10 MHz - 40 GHz	8555A/8552B/141T or equivalent
Amplifier (If Required)	
7-11 GHz	HP-495A, or equivalent
Power Meter (If Required)	
7-11 GHz	HP434, or equivalent
Connectors & Adapters	as required

In performing the measurements, the following procedures should be followed for each antenna combination to be considered:

1. Disconnect the transmission lines associated with the transmitting and receiving equipments under consideration at the input to the respective equipments and connect them to the test instruments as shown.
2. Tune the signal generator and spectrum analyzer to a frequency within the operating range of the transmitting antenna.
3. Set the attenuator control for the signal generator in its highest position (lower power output).

4. Set the sensitivity control of the analyzer in its mid-range position and the attenuator in its lowest position.
5. Increase the power output of the generator until a clearly visible signal is shown on the spectrum analyzer display and record the output power of the generator in dBm as well as the reference level to be used with the analyzer.
6. Decrease the generator output signal to a minimum level (maximum attenuation).
7. Disconnect the test equipment from the Sabreliner transmission lines and connect the signal generator directly to the spectrum analyzer through a short piece of transmission line as indicated for the signal substitution path in the figure.
8. Increase the power output of the signal generator until the visible signal to the analyzer is at an identical level to that previously recorded.
9. Record the output level of the generator in dBm.
10. The coupling loss is equal to the algebraic difference in dBm, between the output power recorded for the direct path and the output power recorded for the substitution path.
11. Repeat the measurement four additional times at different frequencies within the operating range of the transmitter.
12. Reverse the antenna connections and perform the measurements five additional times on the operating frequencies previously used.
13. Repeat the procedure for each transmitting antenna with an operating frequency above 1000 MHz.

Special Procedures for 7-11 GHz Substitution Measurements

When the operating frequency is between 7-11 GHz, it may be necessary to further amplify the signal generator output to obtain a usable direct path signal on the spectrum analyzer display. If this becomes necessary the following procedures apply:

1. Insert the amplifier between the signal generator and transmitting antenna as shown by the dashed lines in Figure II-2.
2. Increase the power of the signal generator until a usable signal is observed on the analyzer.
3. Record the output power indicated on the signal generator.
4. Reduce the output level of the signal generator and substitute the power meter for the transmitting antenna.
5. Increase the output level of the signal generator to the level recorded in 3.
6. Record the amplifier output level as indicated by the power meter.

7. Disconnect the signal generator from the amplifier, disconnect the analyzer from the receiving antenna, and connect the test instruments to each other as shown in the figure as the substitution path.

8. Perform Steps 8 - 13 as described in the previous procedures.

Precautions to be Followed

It is desirable that these measurements be made while the Sabreliner is in flight to minimize perturbations due to objects in the physical environment. In addition, all of the transmitting equipment installed on the airplane should be de-energized for these tests to prevent contamination of the measurements by undesired signals. It is recognized, however, that these two options may be mutually exclusive. Since the second factor is obviously more important in terms of potential effects on the observed data and more easily achieved from a logistical point of view, it appears satisfactory to perform the measurements while the aircraft is on the ground. Nevertheless, the aircraft should be in an area which is as clear as possible with respect to nearby metal objects, and the test frequencies chosen should be separated as far as is feasible from the frequencies in use by the nearby operational equipments.

Finally, although Figure 3-3 of this report contains no coupling loss predictions involving the HF long wire antenna on the Sabreliner, the measured value of the losses between the HF antenna and other antennas on the aircraft should be obtained. Further, the losses should be obtained on at least five operating frequencies within the HF range.

APPENDIX III**FREQUENCY ANALYSIS SYSTEM (FAS) SUBROUTINE**

This Appendix contains the flow diagram and the program listing for the FAS subroutine used to calculate the relative rejection characteristics of receivers. The flow chart is shown in Figure III-1. The program listing, which is written in the FORTRAN V language, is shown in Figure III-2.

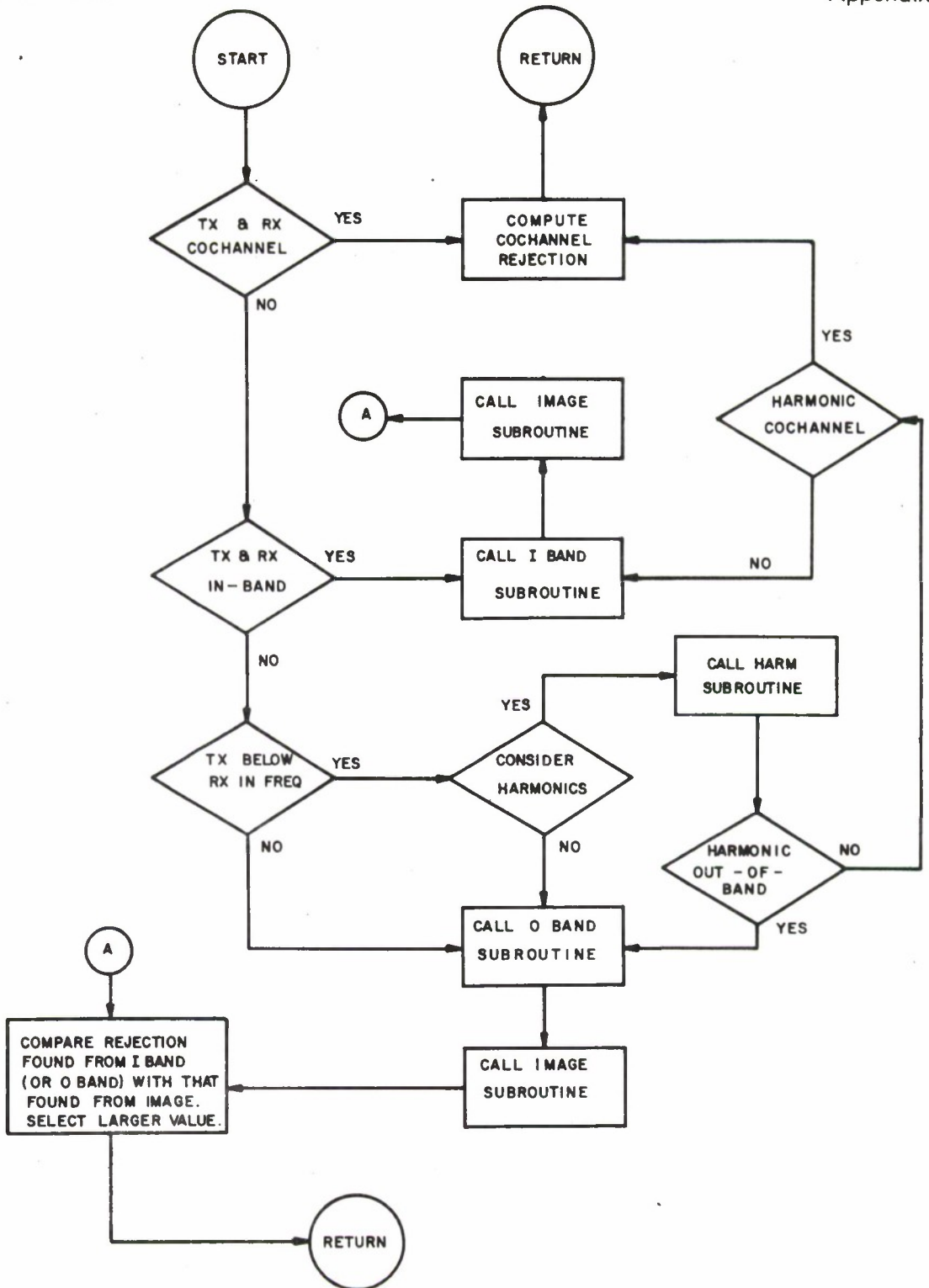

Figure III-1. FAS Flow Chart.

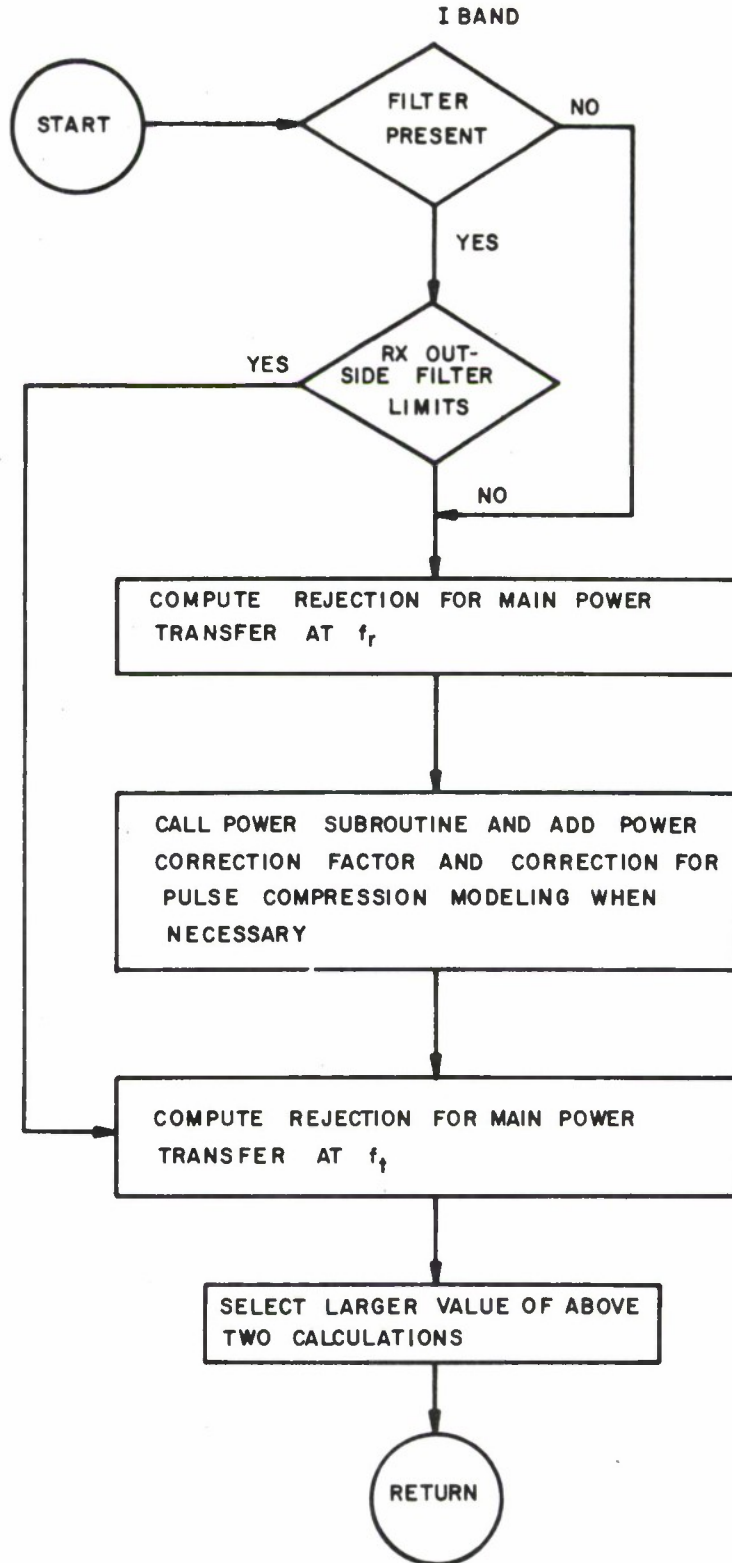

Figure III-1. (Continued).

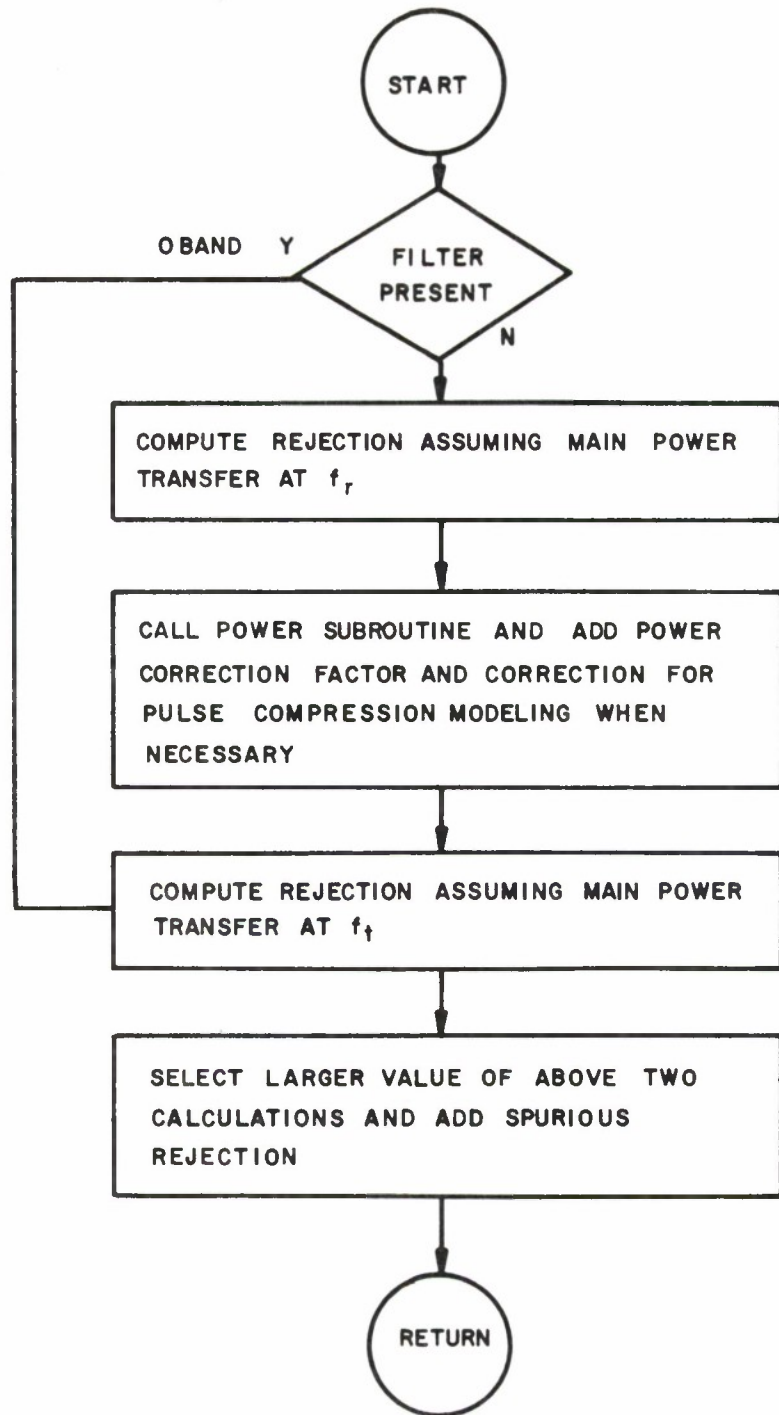

Figure III-1. (Continued)

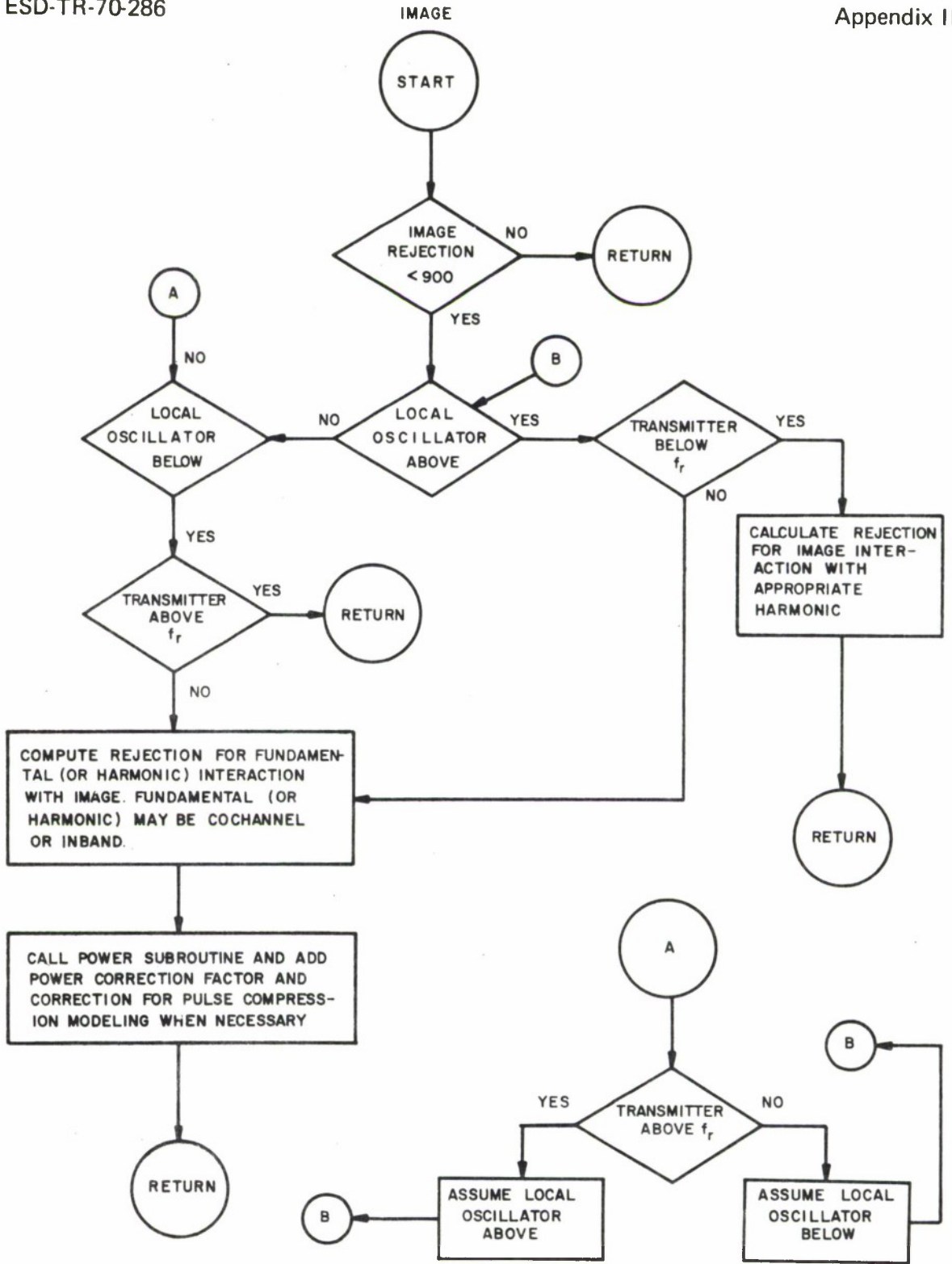

Figure III-1. (Continued).

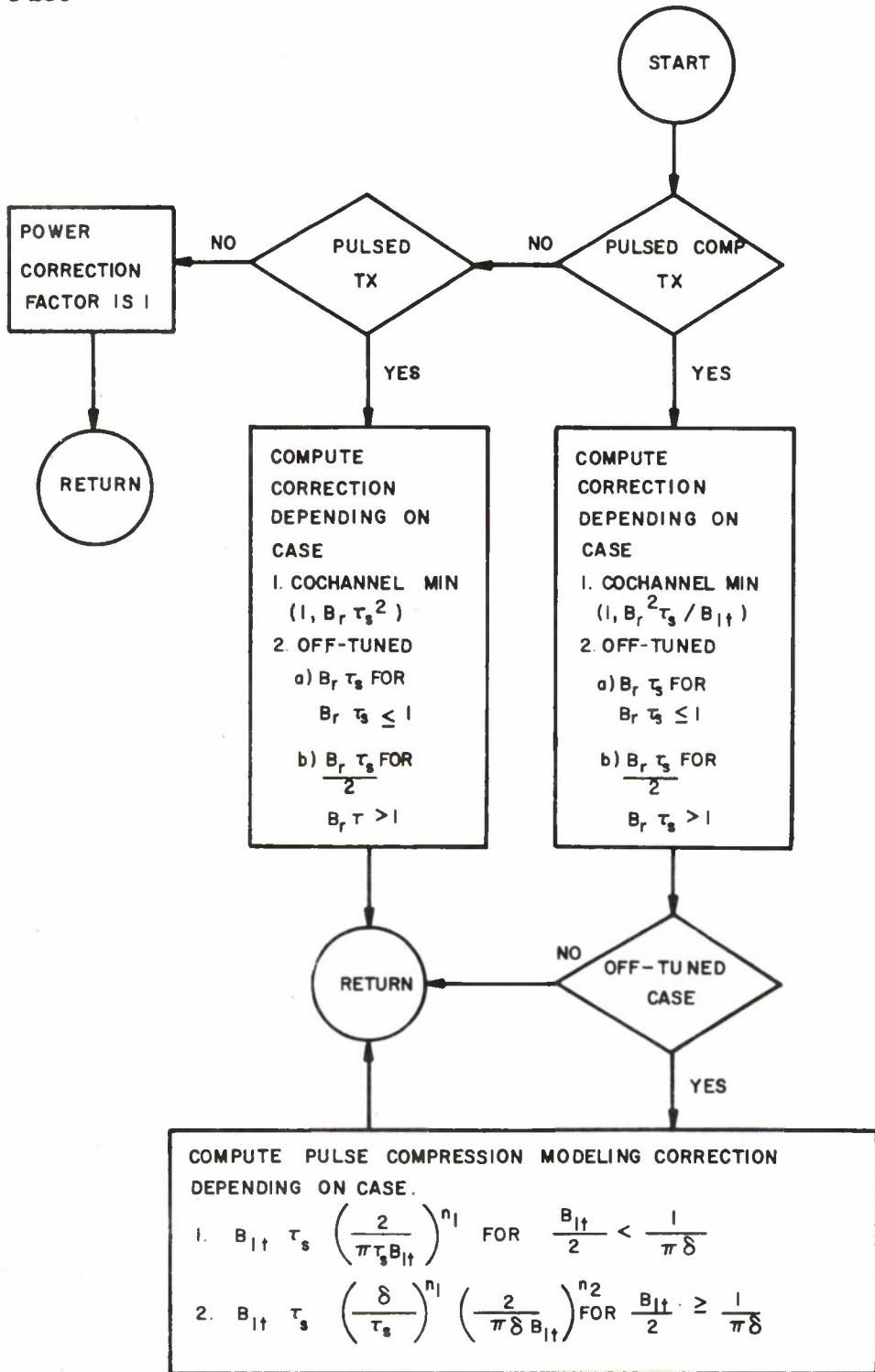

Figure III-1. (Continued).

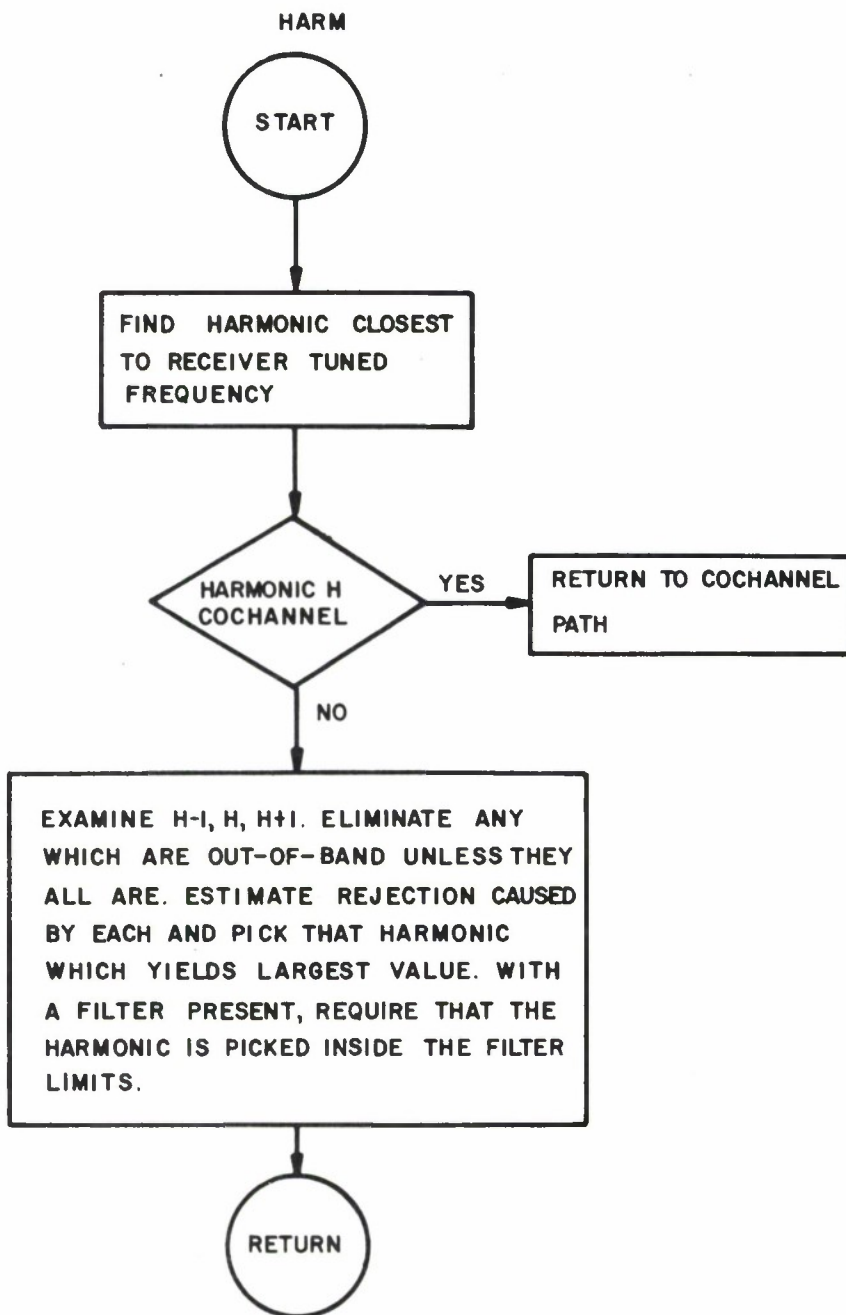

Figure III-1. (Continued).

```

00101 20 C
00101 30 C *** THIS SUBROUTINE CALCULATES OFF-FREQUENCY REJECTION
00101 40 C
00101 50 C *** INPUT PARAMETERS
00101 60 C
00101 70 C *** RECEIVER
00101 80 C
00101 90 C *** F1,F2N - LOWER AND UPPER LIMITS OF TUNED FREQUENCY I MHz
00101 100 C *** FA,FB - LOWER AND UPPER FREQUENCY CUTOFF FOR SPURIOUS RESPONSE I MHz
00101 110 C *** M1,M2 - FIRST AND SECOND SELECTIVITY SLOPE FALLOFFS 100/DECI
00101 120 C *** BM - BANDWIDTH I MHz
00101 130 C *** FIF - INTERMEDIATE FREQUENCY I MHz
00101 140 C *** LOP - LOCAL OSCILLATOR POSITION (A=ABOVE, B=BELOW, C=UNKNOWN)
00101 150 C *** KI - IMAGE REJECTION 1001
00101 160 C *** KS - SPURIOUS REJECTION 1001
00101 170 C
00101 180 C *** TRANSMITTER
00101 190 C
00101 200 C *** F1,F2T - LOWER AND UPPER LIMITS OF TUNED FREQUENCY I MHz
00101 210 C *** FC,FU - LOWER AND UPPER LIMITS OF FILTER I MHz
00101 220 C *** B1T,B2T - FIRST AND SECOND BANDWIDTHS I MHz
00101 230 C *** N1,N2 - FIRST AND SECOND EMISSION SPECTRUM SLOPE FALLOFFS 100/DECI
00101 240 C *** N11 - MAXIMUM HARMONIC NUMBER TO CONSIDER 11 TO 91
00101 250 C *** KH(8) - HARMONIC REJECTION 1001 UP TO EIGHT DIFFERENT LEVELS ALLOWED
00101 260 C *** IT36 - MODULATION TYPE
00101 270 C *** IPCOMP - PULSE COMPRESSION INDICATOR
00101 280 C *** TAU - STRETCHED PULSEWIDTH I USEC
00101 290 C *** PRT - PULSE RISE TIME I USEC
00101 300 C
00103 310 REAL M1,K1,KS,M2,N1,KN,M2,LF,LF1,LF2,LF3
00104 320 INTEGER N,CCHNL
00105 330 COMMON/RBLOCK/A1321,F1,F2R,B121,M1,F1N,F2R,K1,KS,LOP,C,F1,D131,M2,
00106 340 *E(17),FA,FB,HBL(140)
00107 350 COMMON/TBLOCK/W1331,B1T,F11,IT36,N1,F1T,F2T,N101,N2,G131,PRT,
00108 360 *GG(21,TAU,R13),IPCOMP,FC,FO,RN141,B2T,N11,YBL(141)
00109 370 COMMON/PBLOCK/A1191,LF,UB(21),H,PBL(37)
00110 380 C *** THIS COMMON BLOCK IS GENERATED BY DFR
00111 390 COMMON/ZBLOCK/C6MNL,PC,LF1,LF2,LF3,OF,OF5,BH,IMAG,F1P,F2P,OF1,OF2,
00112 400 *OF3,OF4,OF5,DF6,DF7,L1,DF7L2,P1
00113 410 DATA P1/3.1415927/IC/IHC/
00114 420 P1=N1/10*
00115 430 IF(IPCOMP.EQ.1) GO TO 1
00116 440 GO TO 3
00117 450 1 IF(B1T/2*LT.1/(M1*PRT)) GO TO 3
00118 460 N1=N2
00119 470 3 IMAG=0
00120 480 H=1
00121 490 CCHNL=0
00122 500 N1=N1/10
00123 510 N2=N2/10
00124 520 M1=M1/10
00125 530 M2=M2/10
00126 540 OF1=OF1-F2R
00127 550 OF2=OF1-F2T
00128 560 BM=MAX(1,B1T,M1)

```

Figure III-2. FAS Program Listing.

```

00135 570      F1P=F1H
00136 580      F2P=F2H
00137 590      OFF1L1=FIT-FC
00140 600      OFF1L2=FO-F2T
00141 610      IF (OF1=0) 80,80,81
00144 620      80 IF (OF2=0) 120,20,81
00147 630      81 IF (FIT.GT.FB+B2T/2) GO TO 10
00151 640      IF (F2.LT.FA-B2T/2) GO TO 10
00153 650      GO TO 30
00153 660      C *** TRANSMITTER TUNED OUTSIDE OF RECEIVER TUNING RANGE R, WHERE
00153 670      C ***      FA=B2T/2 < R < FB+B2T/2
00154 680      10 IF (OF2-(B2T*NR1/2) (2,1),11
00157 690      12 IF (OF1).LT.(B2T*NR1/2) GO TO 60
00157 700      C *** TRANSMITTER TUNED ABOVE RECEIVER
00161 710      DF=DF1
00162 720      DFS=FB-F2H
00163 730      GO TO 8888
00163 740      C *** TRANSMITTER TUNED BELOW RECEIVER BY (NR+B2T)/2
00164 750      11 CALL HARMIS2J1
00165 760      17 IF (H*2T+LT+FA-(B2T*NR1)/2) GO TO 18
00167 770      IF (H*2T+GT+FB+(B2T*NR1)/2) GO TO 15
00171 780      GO TO 7777
00172 790      16 DFS=F3-F2H
00173 800      GO TO 8888
00174 810      15 IF (H=2) 16,16,16
00174 820      C *** THE SECOND HARMONIC IS OUT OF BAND AND THE FUNDAMENTAL IS EVEN FARTHER
00174 830      C *** AWAY (I.E. OUTSIDE OF RECEIVER TUNING RANGE)
00177 840      18 DFS=F1R-FA
00200 850      GO TO 8888
00200 860      C *** TRANSMITTER AND RECEIVER ARE COCHANNEL
00201 870      20 CCHNL=J
00202 880      CALL POREN
00203 890      LF=PC
00204 900      22 IF (H=2) 9999,24,24
00207 910      24 ALFP=LF-KH(H=1)
00210 920      GO TO 6666
00210 930      C *** THE TRANSMITTER IS LESS THAN BR/2 AWAY FROM THE RECEIVER TUNING RANGE
00211 940      60 IF (F1H-FA-(B2T*NR1/2) 65,65,67
00214 950      67 IF (FB-F2H-(B2T*NR1/2) 65,65,69
00217 960      69 IF (OF1=0) 66,66,70
00222 970      66 DF=DF2
00223 980      DFS=F1R-FA
00224 990      GO TO 8888
00225 1000     70 DF=DF1
00226 1010     DFS=FB-F2H
00227 1020     GO TO 8888
00230 1030     65 IF (OF1.GT.0) GO TO 68
00232 1040     DF=DF2
00233 1050     GO TO 7777
00234 1060     68 DF=DF1
00235 1070     GO TO 7777
00236 1080     C *** THE TRANSMITTER IS WITHIN THE RECEIVER TUNING RANGE
00236 1090     30 IF (OF2.GT.BH/2) GO TO 15
00240 1100     IF (OF1)=BH/2 (20,20,32
00243 1110     32 DF=DF1

```

Figure III-2. Continued.

```

00244 1120 IF IABS(LF1-BM/2) 70.20,7777
00244 1130 C 000 THE TRANSMITTER IS FAR ENOUGH AWAY FROM THE RECEIVER THAT HARMFULICS
00244 1140 C 000 MUST AT LEAST BE CONSIDERED AS THE INTERACTION CAUSING OFM TO BE GREATEST
00247 1150 35 CALL HARMIS20)
00250 1160 GO TO 7777
00251 1170 6666 HHEM
00252 1180 CALL IMAGL
00253 1190 IF (ALP-LF3) 6667,6666H,6666H
00256 1200 6667 LF=LF3
00257 1210 GO TO 9999
00260 1220 6666 HHHH
00261 1230 LF=LF1P
00262 1240 GO TO 9999
00263 1250 7777 CALL IBAND
00264 1260 ALFP=AMARI(LF1,LF2)
00265 1270 GO TO 6666
00266 1280 8888 CALL DBAND
00267 1290 ALFP=AMARI(LF1,LF2)
00270 1300 GO TO 6666
00271 1310 9999 NI=10*NI
00272 1320 NZ=10*NZ
00273 1330 MI=10*MI
00274 1340 MZ=10*MZ
00275 1350 IF (LF.GT.C*DBAND.B*ETAU.GT.1.) LF=0.
00277 1360 IF (IFCOMP.NE.1C) RETURN
00301 1370 IF (BIT/2.LT.1/(PI*PRT)) RETURN
00303 1380 NI=PI*10*
00304 1390 RETURN
00305 1400 END
    
```

Figure III-2. Continued.

Figure III-2. Continued.

SUBROUTINE QMANS ENTRY POINT Q0J3Z5
STORAGE USED (BLOCK, NAME, LENGTH)

0001 *CODE 000333
0000 *DATA 000046
0002 *BLANK 000000
0003 *BLOCK 000317
0004 *BLOCK 000320
0005 *BLOCK 000074
0006 *BLOCK 000023

EXTERNAL REFERENCES (BLOCK, NAME)

0007 INTRUP
0010 POWER
0011 NEAP65
0012 ALOG10
0013 MERR35

STORAGE ASSIGNMENT FOR VARIABLES (BLOCK, TYPE, RELATIVE LOCATION, NAME)

0001	000304	10L	000263	11L	0001	000144	2L	0001	000171	%L								
0001	000124	6L	0001	000132	7L	0001	000132	9L	0003	000000	A							
0002	000000	AA	0003	000042	B	0005	000024	0B	0003	000041	BR							
0004	H	000041	RIT	0004	R	000101	B2T	0003	000054	O								
0006	R	000005	UF	0000	R	000000	UFA	0000	R	000003	OFF							
0006	R	000021	OFF11	0006	R	000022	OFF12	0000	R	000013	OFF							
0006	R	000014	UF2	0006	R	000015	UF3	0006	R	000017	UF1							
0003	000060	E	0004	000042	F	0004	000101	FA	0006	000020	OF6							
0004	000074	FU	0003	000053	F1	0003	000040	F1F	0004	000073	FC							
0003	000045	FTR	0004	000045	F1T	0000	R	000013	F12	0006	000011	F1P						
0000	H	000017	F16	0006	H	000012	F2P	0003	000046	F2R	0000	000016	F15					
0000	R	000011	F6	0000	H	000012	F7	0004	000046	F2H	0000	H	000010	F5				
0000	I	000005	I	0006	H	000010	IMAU	0000	000030	INJPS	0005	I	000026	H				
0000	I	000006	J	0004	H	000047	KM	0003	R	000047	K1	0004	000043	IT36				
0006	K	000002	LFI	0006	H	000003	LF2	0006	R	000004	LF3	0003	R	000023	LF			
0003	R	000057	M2	0004	H	000044	M1	0004	R	000051	LOP	0003	H	000044	M1			
0006	K	000001	PC	0004	000063	PRT	0004	000102	M11	0004	R	000057	M2	0005	000027	PBL		
0004	000075	RR	0004	000066	TAU	0004	000000	Q	0004	000067	R	0003	000103	NBL	0000	R	000020	ZZ

00103 10 SUBROUTINE QMANS
00103 20 REAL M1,K1,KS,M2,M1,KM,M2,LF,LF1,LF2,LF3

Figure III-2. Continued.

```

0-101      10      SUBROUTINE IMA D
00103      20      REAL M1,K1,KS,M2,N1,KH1,N2,LF,LF1,LF2,LF3
00104      30      INTEGER CCHNL
00105      40      INTEGER M
00106      50      COMMON/MBLOCK/A(37),F,FB,M,B(21,M),FH,FZ,K1,KS,LOP,C,F1,D(3),-2,
00106      60      *E(17),FA,FB,HBL(140)
00107      70      COMMON/TBLOCK/%(33),B)Y,F(1),IT36,M1,F1T,FZT,KH(8),N2,G(31),PNT,
00107      80      *GG(2),TAU,R(3),IPCOMP,FC,FD,RN(4),B2T,M11,TBL(14))
00110      90      COMMON/PBLOCK/AA(19),LF,BH(21,M),PML(37)
00110     100      C *** THIS COMMON BLOCK IS GENERATED BY OFM
00111     110      COMMON/ZBLOCK/CCHNL,PC,LF1,LF2,LF3,OF,OF5,FM,(IMAGE,F11,F2P,OF1,
00111     120      *OF2,OF3,OF4,OF5,OF6,OFFIL1,OFFIL2
00112     130      CCHNL=0
00113     140      CALL INTRUP(1,J,9)01
00114     150      OF=ABS(OF)
00115     160      OFA=ABS(OF-BR/2)
00116     170      OFB=B2T/2
00117     180      OFC=OF*BR/2
00120     190      OFD=OF*BIT/2
00121     200      OFE=ABS(OF-BIT)/21
00122     210      F1=1/BIT
00123     220      F2=1/(M1-1)
00124     230      F3=(BIT/(2*OF+1+M1))*DFR
00125     240      IF (OF.LT.(BM+H)/2) GO TO 1000
00127     250      F4=(BIT/(2*OFA+M1))*OFA
00130     260      F9=(BR/(2*OFE+M1))*OFE
00131     270      CF=0
00132     280      GO TO 1001
00132     290      C *** THE TRANSMITTER AND RECEIVER ARE NOT CO-CHANNEL, BUT LARGE BANDWIDTHS
00132     300      C *** CAUSE THE EMISSION SPECTRUM AND SELECTIVITY CURVES TO OVERLAP, WHICH
00132     310      C *** RECESSITATES CORRECTIONS TO THE OFM INTEGRAL
00133     320      1000 F4=BIT/2
00134     330      F9=BR/2
00135     340      CF=(BIT+BR)/2 - OF1 * F1
00136     350      1001 F5=(BIT/B2T+M1)
00137     360      F6=1/(N2-1)
00140     370      F7=(OFB/OFC+M2)*OFC
00141     380      FB=OFB
00142     390      F12=(N2T/(2*OFA)+M2)*OFA
00143     400      F13=(BIT/(2*OFC)+M1)*OFC
00143     410      C *** IF THE RECEIVER TUNED FREQUENCY LIES OUTSIDE THE FILTER LIMITS,
00143     420      C *** NO CALCULATION FOR MAXIMUM POWER TRANSFER AT THE RECEIVER TUNED
00143     430      C *** FREQUENCY IS MADE (FILTER IS ASSUMED IDEAL)
00144     440      IF(PC=0)89,89,79
00147     450      79 IF(M=N2-1) GO TO 84
00151     460      IF(ABS(OF1)-ABS(OF21)83,83,81
00154     470      83 IF(ABS(OF1)-OFFIL1)89,31,31
00157     480      81 IF(ABS(OF21)-OFFIL2)89,31,31
00162     490      84 IF((M-1)*F2.GT.OFFIL2) GO TO 31
00164     500      89 IF(OF-BR+B2T)/21 92,90,90
00167     510      92 IF(OFB-OFC)93,91,91
00172     520      93 Z=OF1 * ((F4 - F3)1 + F2 + F5 + F6 + 1 FB - F7)1)
00173     530      99 Z = Z * CF
00174     540      IF (Z = 0.) 10,10,999
    
```

Figure III-2. Continued.

```

550 C *** THE RECEIVER 'BOXCAR' INTERSECTS THE TRANSMITTER EMISSION SPECTRUM
560 C *** ON BOTH SLOPES (MAXIMUM POWER TRANSFER AT RECEIVER TUNED FREQUENCY)
570 999 LFI = 10 * ALOG10(Z1)
580 30 CALL POWEM
590 LFI=LF1*PC
600 GO TO J2
610 J1 LFI=999.
620 J2 CALL INTRUP(1,J1,S201)
630 F10=(18R/(2*DFD1))*.M11*OFO
640 F11=(M1-1)
650 Z2 = F1 * F11 * ( FV - F10 I
660 Z2 = Z2 * CF
670 IF IZ2 = 0.1 Z0,Z0,Z00
680 C *** THE TRANSMITTER 'BOXCAR' INTERSECTS THE RECEIVER SELECTIVITY CURVE
690 C *** EITHER ON THE FIRST SLOPE OR AT THE SPURIOUS LEVEL (MAXIMUM POWER AT
700 C *** TRANSMITTER TUNED FREQUENCY)
710 200 LPZ=10*ALOG10(Z2)
720 40 IF IIMAGE=9.11 RETURN
730 C *** THE FOLLOWING THREE STATEMENTS COMPENSATE FOR A COMPILER ERROR
740 KS=KS
750 CCMLE=1
760 CALL POWEM
770 KSPAKS=PC
780 CCMLE=0
790 LPZ=AMAX1(LPZ,KSP)
800 KS=KS
810 IF IN=21999.60,40
820 40 LFI=LF1-K*(M-1)
830 LPZ=LF2-K*(M-1)
840 9999 CALL INTRUP(11)
850 RETURN
860 C *** RECEIVER 'BOXCAR' INTERSECTS TRANSMITTER EMISSION SPECTRUM ON THE
870 C *** SECOND SLOPE FALLOFF (MAXIMUM POWER TRANSFER AT RECEIVER TUNED FREQUENCY)
880 90 Z = F1 * F5 * F6 * I F12 = F7 I
890 GO TO 99
900 C *** RECEIVER 'BOXCAR' INTERSECTS TRANSMITTER EMISSION SPECTRUM ON THE
910 C *** FIRST SLOPE FALLOFF (MAXIMUM POWER TRANSFER AT RECEIVER TUNED FREQUENCY)
920 91 Z = F1 * F2 * ( F4 = F13 I
930 GO TO 99
940 10 LFI = -400.
950 GO TO J0
960 20 LFZ = -400.
970 GO TO 40
980 END

```

Figure III-2. Continued.

SUBROUTINE IRAND ENTRY POINT 00010
 STORAGE USED (BLOCK, NAME, LENGTH)
 0001 *CODE 000520
 0000 *DATA 000061
 0002 *BLANK 000000
 0003 *BLOCK 000317
 0004 *BLOCK 000320
 0005 *BLOCK 000074
 0006 *BLOCK 000023

EXTERNAL REFERENCES (BLOCK, NAME)

0007 INTRUP
 0010 POPER
 0011 NEAP63
 0012 ALG610
 0013 MEMR35

STORAGE ASSIGNMENT FOR VARIABLES (BLOCK, TYPE, RELATIVE LOCATION, NAME)

0001	000465	10L	0001	000114	1000L	0001	000130	1001L	0001	000470	20L	0001	000313	30L				
0001	000321	31L	0001	000323	32L	0001	000366	40L	0001	000231	81L	0001	000237	89L				
0001	000251	89L	0001	000446	90L	0001	000456	91L	0001	000300	99L	0001	000440	9999L				
0003	000000	A	0005	000000	AA	0003	000042	B	0005	000024	Bb	0006	000007	Bb				
0003	M	000041	BK	0004	M	000041	B1Y	0004	R	000101	B2T	0006	I	000000	CCHHL			
0004	R	000014	CF	0004	M	000054	C	0004	R	000005	DF	0000	R	000003	DFB			
0000	R	000014	DFC	0000	R	000005	DFD	0000	R	000006	DFE	0006	R	000022	OFFILLZ			
0006	000006	DFS	0006	R	00013	DFI	0006	R	000014	DFJ	0006	R	000016	DF4				
0006	00017	DFS	0006	000020	DF6	0003	000060	E	0004	000042	F	0006	R	000101	FA			
0003	000102	FR	0004	M	000073	FC	0004	000074	FD	0003	000053	FI	0003	000040	FI1F			
0000	R	000007	FI	0004	000011	FI1P	0003	000045	FI1M	0004	000045	FI1Y	0000	M	000024	FIU		
0000	R	000025	FI1	0000	M	000021	FI2	0000	R	000022	FI3	0000	R	000012	F2P			
0003	000046	F2R	0004	R	000046	F2T	0000	R	000011	F3	0000	R	000015	F5				
0000	R	000016	F6	0000	M	000017	F7	0000	R	000020	F8	0000	M	000013	F9			
0004	000064	GG	0005	I	000026	H	0000	I	000000	I	0006	I	000010	IMAGE				
0004	000072	IPCOMP	0004	000043	I136	0000	I	000001	J	0004	R	000047	KN	0000	000037	INJPS		
0003	R	000050	KS	0000	I	000027	KSP	0005	R	000023	LF	0006	M	000003	LF2			
0006	R	000004	LF3	0003	R	000051	LOP	0003	R	000044	M1	0003	R	000044	M1			
0004	000102	N11	0004	M	000057	L2	0005	000027	P8L	0004	R	000001	PC	0004	0b0003	PRT		
0004	000000	Q	0004	000067	M	0004	000067	M	0003	000103	R4L	0004	R	000076	RR	0000	000066	TAU
0004	000103	T8L	0000	M	000023	Z	0000	R	000026	ZZ								

Figure III-2. Continued.

```

00104 INTEGER CCMNL
00105 INTEGER M
00106 COMMON/BLCK/AL3Z1,F1,FR,B1Z1,M1,F1,FR,K1,NS,LOP,C,F1,013),M2,
00107 *E1171,FA,FB,MBL1140)
00108 COMMON/BLCK2/(33),BIT,F111,IT36,M1,F1T,F2T,M(8),M2,G(3),PRT,
00109 *G6121,TAU,R131,IPCMP,PC,FO,PR(4),B2T,M11,TBL1141)
00110 COMMON/BLCK3/AL191,LP,88(2),MAPBL137)
00111 C *** THIS COMMON BLOCK IS GENERATED BY OFM
00112 *OF2,OF3,OF4,OF5,OF6,OFFIL1,OFFIL2
00113 CCMNL=U
00114 OF=ABS(OF)
00115 OF5=ABS(OF5)
00116 OFA=ABS(OF-BN/Z1)
00117 OFB=M21/2
00118 OFC=OF+BR/Z2
00119 OFF=OF+BIT/2
00120 OF6=ABS(OF-BIT/Z1)
00121 CALL INTRUP(I,J,S10)
00122 F1=1/81T
00123 FB=(BIT/B2T)*M1
00124 F6=1/(M2-1)
00125 F7=(1/OFB/OFC)*(M2)*OFC
00126 F12=((M2T/120F81)*M21*OFA
00127 C *** IF THE RECEIVER TUNED FREQUENCY LIES OUTSIDE THE FILTER LIMITS,
00128 C *** NO CALCULATION FOR MAXIMUM POWER TRANSFER AT THE RECEIVER TUNED
00129 C *** FREQUENCY IS MADE (FILTER IS ASSUMED IDEAL)
00130 IF(FC=012.2)1
00131 1 IF(M,NE,116) TO 9
00132 2 IF(ABS(OF1)-ABS(OF2)) 5,6,6
00133 5 IF(ABS(OF1)-OFFIL1) 2,4,4
00134 6 IF(ABS(OF2)-OFFIL2) 2,4,4
00135 9 IF((M-1)*F2T-G1,OFFIL2) GO TO 4
00136 C *** RECEIVER 'BOCAR' INTERSECTS TRANSMITTER EMISSION SPECTRUM ON THE
00137 C *** SECOND SLOPE FALLOFF (MAXIMUM POWER TRANSFER AT RECEIVER TUNED FREQUENCY)
00138 2 2= F1 * F5 * F6 * ( F12 - F7 )
00139 3 IF(2 - 0.) 10,10,3
00140 3 LFI=10*ALOG10(F12)
00141 CALL POWER
00142 LFI=LFI*PC
00143 GO TO 7
00144 4 LFI=999.
00145 7 CALL INTRUP(I,J,S20)
00146 F14=1/IN2-11
00147 F15=OF5/OF61*(M2)*OFC
00148 F16=(LFI/OF1)*M2*OFF
00149 C *** THE TRANSMITTER 'BOCAR' INTERSECTS THE RECEIVER SELECTIVITY CURVE
00150 C *** ON THE SECOND SLOPE (MAXIMUM POWER TRANSFER AT THE TRANSMITTER TUNED FREQ,
00151 22=F1 * F14 * ( F15 - F16 )
00152 50 IF(22 - 0.) 20,20,8
00153 8 LFI=10*ALOG10(F22)*K5
00154 IF(BR,LT,011) LFI=LFI*10*ALOG10(BN/81T)
00155 11 IF(M=2) 999,80,80
00156 80 LFI=LFI-K4(M-1)
00157 LFI=LFI*2-K4(M-1)
00200 9999 CALL INTRUP(11)
00201 RTURN
00202 10 LFI=900.
00203 GO TO 7
00204 20 LFI=900.
00205 GO TO 11
00206 EN0
00207 640

```

Figure III-2. Continued.

SUBROUTINE IMAGL ENTRY POINT 000512

STORAGE USED (BLOCK, NAME, LENGTH)

```

0001 *COOL 000515
0000 *DATA 000024
0002 *BLANK 000000
0003 *BLOCK 000317
0004 *BLOCK 000320
0005 *BLOCK 000074
0006 *BLOCK 000023
    
```

EXTERNAL REFERENCES (BLOCK, NAME)

```

0007 *MATH
0010 *BAND
0011 *POWER
0012 *NERK65
0013 *NERK35
    
```

STORAGE ASSIGNMENT FOR VARIABLES (BLOCK, TYPE, RELATIVE LOCATION, NAME)

```

0001 000422 10L 0001 000443 12L 0001 000446 13L 0001 00014 2L 0001 000460 20L
0001 000021 3L 0001 000322 30L 0001 000337 31L 0001 000342 32L 0001 000027 4L
0001 000345 40L 0001 000352 41L 0001 000361 42L 0001 000364 43L 0001 000371 44L
0001 000376 45L 0001 000407 46L 0001 000417 47L 0001 000433 5L 0001 000056 6L
0001 000073 7L 0001 000164 70L 0001 000171 71L 0001 000177 72L 0001 000202 73L
0001 000215 74L 0001 000232 75L 0001 000263 76L 0001 000314 77L 0001 000124 8L
0001 000155 9L 0001 000502 999L 0003 000000 6A 0003 000042 8 0003 000042 8
0004 000024 8B 0006 M 000007 8M 0003 000041 8K 0004 000041 8T 0004 000101 8ZT
0003 000052 C 0006 I 000000 CCHML 0003 000054 O 0004 R 000005 OF 0004 000021 OFFIL1
0004 000022 OFFIL2 0000 K 000005 UFM 0006 000006 OFS 0000 R 000004 OFU 0006 M 000013 OFI
0004 000014 OF2 0006 000015 OF3 0006 000016 OF4 0006 000017 OF5 0006 000020 OF6 0004 000020 OF6
0003 000040 L 0004 000042 I 0003 000101 FA 0003 000102 FB 0004 000073 FC 0004 000073 FC
0004 000074 FO 0003 000053 FI 0003 M 000040 FIF 0004 M 000011 FIP 0003 R 000045 FIR 0004 R 000045 FIR
0004 000045 FIT 0006 M 000012 F2P 0003 R 000046 F2H 0004 K 000046 F2T 0004 000060 6
0004 000045 G 0005 I 000026 H 0000 I 000000 I6 0000 I 000001 Iw 0000 I 000002 IC
0004 000045 G6 0004 000010 IMAGE 0004 000013 INJP4 0004 000072 IPLOMP 0004 R 000043 I736 0004 R 000047 KM
0003 R 000047 KI 0003 R 000050 KS 0005 R 000023 LF 0006 R 000002 LF1 0006 R 000003 LF2 0006 R 000003 LF2
0004 R 000044 LF3 0000 I 000003 LOP 0000 I 000051 LOPP 0003 R 000044 M1 0003 R 000047 M2 0003 R 000057 M2
0004 000044 NI 0004 000102 N11 0004 000057 N2 0004 R 000001 PC 0004 R 000001 PC
0004 000043 PNT 0004 000000 4 0004 000067 R 0004 000067 R 0004 000075 RR 0004 000075 RR
0004 000066 TAU 0004 000103 T6L 0003 000103 T6L
    
```

Figure III-2. Continued.

```

00101 10 SUBROUTINE IMAGE
00103 20 REAL MI,K1,K5,M2,M1,KH,NZ,LF,LF1,LF2,LF3
00104 30 INTEGER CMNL
00105 40 INTEGER M
00106 50 COMMON/RBLOCK/A(32),FI,FM,8(2),MI,FIM,F2R,K1,K5,LOPP,C(FI,013),N2
00106 60 ,E(17),FA,FB,NH,11401
00107 70 COMMON/TBLOCK/G(33),B,T,F1,IT,36,M1,FIT,F2T,KH(8),M2,G(3),PRT,
00107 80 ,GG(2),TAU,R(3),IPCOMP,FC,FO,RH(4),B2T,N11,TBL11411
00110 90 COMMON/PBLOCK/A(19),LF,MM(2),M,PBL(37)
00110 100 C ** THIS COMMON BLOCK IS GENERATED BY OFR
00111 110 COMMON/ZBLOCK/CMNL,PC,LF1,LF2,LF3,OF,OF5,ON,IMAGE,FI1,F2P,OF1,
00111 120 ,OF2,OF3,OF4,OF5,OF6,OFFIL1,OFFIL2
00112 130 DATA 1A/1MA/1B/1MB/1C/1MC/
00116 140 IMAGE=1
00117 150 M=1
00120 160 LOP=LOPP
00120 170 C ** THE USER HAS THE OPTION OF NOT HAVING THE IMAGE INTERACTION
00120 180 C ** CONSIDERED BY ENTERING A VALUE OF 900 OR GREATER FOR IMAGE REJECTION
00121 190 IF(K1-900.12).1
00124 200 1 LF3=-900.
00125 210 GO TO 999
00126 220 2 IF(LOP.EQ.1A)GO TO 3
00130 230 GO TO 70
00130 240 C ** IF THE LOCAL OSCILLATOR IS ABOVE THE RECEIVER AND THE TRANSMITTER IS
00130 250 C ** BELOW, CONSIDER TRANSMITTER HARMONICS' INTERACTION WITH THE IMAGE
00131 260 3 IF(F2T.LT.FIM)GO TO 4
00133 270 GO TO 5
00134 280 4 FIP=FIR+2*FIF
00135 290 F2P=F2R+2*FIF
00136 300 CALL HARMISZ01
00137 310 GO TO 10
00137 320 C ** IF THE TRANSMITTER IS BELOW THE IMAGE BY MAX(BIT/2,BR/2) THEN
00137 330 C ** CONSIDER A HARMONIC INTERACTION WITH THE IMAGE
00140 340 5 IF(F2T*BN/2.LT.FIM+2*FIF)GO TO 6
00142 350 GO TO 7
00143 360 6 OFO=FIT-F2R-2*FIF
00144 370 OFN=2*FIT-F2R-2*FIF
00145 380 GO TO 40
00145 390 C ** IS THE LOWER FREQUENCY OF THE TRANSMITTER CO-CHANNEL WITH THE IMAGE?
00148 400 7 IF(FIR+2*FIF*BN/2.GT.FIT.OR.FIT.GT.F2R+2*FIF*BN/2)GO TO 8
00150 410 GO TO 20
00150 420 C ** IS THE UPPER FREQUENCY OF THE TRANSMITTER CO-CHANNEL WITH THE IMAGE?
00151 430 8 IF(FIR+2*FIF*BN/2.GT.F2T.OR.F2T.GT.F2R+2*FIF*BN/2)GO TO 9
00153 440 GO TO 20
00154 450 9 OF=FIT-F2R-2*FIF
00155 460 GO TO 10
00156 470 70 IF(LOP.EQ.1B)GO TO 71
00160 480 GO TO 30
00160 490 C ** IF THE LOCAL OSCILLATOR IS BELOW THE RECEIVER AND THE TRANSMITTER IS
00160 500 C ** ABOVE, SET THE OFN DUE TO AN IMAGE INTERACTION WITH THE TRANSMITTER
00160 510 C ** FUNDAMENTAL EQUAL TO -900 AND RETURN TO CALLING PROGRAM
00161 520 71 IF(FIT.GT.F2R)GO TO 72
00163 530 GO TO 73
00164 540 72 LF3=-900.

```

Figure III-2. Continued.

```

00145 550 GO TO 999
00145 560 C 000 IF THE TRANSMITTER IS BELOW THE IMAGE BY MAX(81T/2,BR/2) THEN
00145 570 C 000 CONSIDER A HARMONIC INTERACTION WITH THE IMAGE
00166 580 73 IF(F2T+BM/2.LT.F1H-2*F1F) GO TO 74
00170 590 GO TO 75
00171 600 74 DFU= F1T-F2R+2*F1F
00172 610 OFH=2*F1T-F2R+2*F1F
00173 620 GO TO 40
00173 630 C 000 IS THE LOWER FREQUENCY OF THE TRANSMITTER CO-CHANNEL WITH THE IMAGE?
00174 640 75 IF(F1H-2*F1F-BM/2.GT.F1T.ON.F1T.GT.F2R-2*F1F+BM/2) GO TO 76
00174 650 GO TO 20
00176 660 C 000 IS THE UPPER FREQUENCY OF THE TRANSMITTER CO-CHANNEL WITH THE IMAGE?
00177 670 7A IF(F1R-2*F1F-BM/2.GT.F2T.ON.F2T.GT.F2H-2*F1F+BM/2) GO TO 77
00201 680 GO TO 20
00202 690 77 OF= F2H-2*F1F-F2T
00203 700 GO TO 10
00204 710 30 IF(F1T.GT.F2R) GO TO 31
00206 720 IF(F2T.LT.F1R) GO TO 32
00210 730 RETURN 0
00211 740 31 LOP=1A
00212 750 GO TO 5
00213 760 32 LOP=1B
00214 770 GO TO 73
00215 780 40 IF(OFH.GT.0) GO TO 41
00217 790 GO TO 44
00220 800 41 IF(OFD.LT.100*OFH) GO TO 42
00222 810 GO TO 43
00223 820 42 OF=OFD
00224 830 GO TO 10
00225 840 43 OF=OFH
00226 850 H=2
00227 860 GO TO 10
00230 870 44 IF(LOP.EQ.1A) GO TO 45
00232 880 GO TO 46
00233 890 45 F1P= F1R+2*F1F
00234 900 F2P= F2R+2*F1F
00235 910 GO TO 47
00236 920 46 F1P= F1R-2*F1F
00237 930 F2P= F2R-2*F1F
00240 940 47 CALL HARM(B20)
00241 950 10 OF1=F1T-F2P
00242 960 OF2=F1P-F2T
00243 970 CALL JBAND
00244 980 IF(LF2-LF1) 11,12,12
00247 990 11 LF3=LF1-K1
00250 1000 GO TO 13
00251 1010 12 LF3=LF2-K1
00252 1020 13 IF(H.LT.2) GO TO 999
00254 1030 LF3=LF3-KH(H-1)
00255 1040 GO TO 999
00256 1050 C 000 CO-CHANNEL PATH
00256 1060 20 CCHNL=1
00257 1070 LF3=K1
00260 1080 CALL POSEN
00261 1090 LF3=L*J*PC
00262 1100 IF(H.LT.2) GO TO 999
00264 1110 LF3=LF3-KH(H-1)
00265 1120 999 RETURN
0026A 1130 END

```

Figure III-2. Continued.

SUBROUTINE HARM ENTRY POINT 001041
 STORAGE USED (BLOCK, NAME, LENGTH)
 0001 *CODE 001054
 0000 *DATA 000132
 0002 *BLANK 000000
 0003 *BLOCK 000317
 0004 *BLOCK 000320
 0005 *BLOCK 000074
 0006 *BLOCK 000023

EXTERNAL REFERENCES (BLOCK, NAME)
 0007 AL061U
 0010 MERR63
 0011 MERR43
 0012 MERR33

STORAGE ASSIGNMENT FOR VARIABLES (BLOCK, TYPE, RELATIVE LOCATION, NAME)

0001	000010	1UL	0001	00100/	1000L	0001	00022	11L	0001	000030	1250	00050	130F	
0001	000113	14L	0001	00007/	1466	0001	00027	15L	0001	000104	16L	00021	17L	
0001	000243	18L	0001	000260	19L	0001	000300	20L	0001	000666	200L	000303	2206	
0001	000311	2266	0001	000375	23L	0001	000330	2356	0001	000503	24L	000307	2406	
0001	000513	25L	0001	000521	26L	0001	000555	27L	0001	000571	28L	000615	29L	
0001	000643	30L	0001	000411	300L	0001	000721	31L	0001	000735	3576	000648	3L	
0001	000752	396L	0001	000725	499L	0003	000800	A	0003	000000	AA	000642	0	
0005	000024	88	0006	R	00000/	88	0004	000941	81T	0004	000941	82T	000191	82T
0003	000052	C	0000	K	000072	CAL1	0000	K	000073	CAL2	0000	K	000074	CAL3
0003	000034	D	0000	K	000033	OEL1	0000	K	000050	DEL2	0006	K	000050	DF
0006	R	000022	UFFIL2	0000	K	000024	UFN	0006	000086	DFS	0006	K	000013	DF1
0006	R	000015	DF3	0006	R	000015	DF4	0006	000017	DFS	0006	R	000020	DF6
0000	R	000070	U2	0000	R	000071	U3	0003	000060	E	0004	000042	F	
0003	R	000102	F8	0004	R	000071	FC	0004	000074	FD	0003	000033	F1	
0006	R	000011	F1P	0003	000045	F1R	0004	K	000045	F1T	0006	K	000012	F2P
0004	R	000046	F2T	0004	000060	G	0004	000064	66	0005	1	000026	M	
0000	I	000062	I	0000	I	000013	IB	0000	I	000066	ILIM	0006	000010	IMAGE
0004	000072	IPCOMP	0004	000045	IT36	0000	I	000075	II	0000	I	000076	12	
0000	I	000064	K	0004	K	00004/	KH	0003	K	000047	KI	0005	I	000063
0006	R	000002	LF1	0006	R	000003	LF2	0006	K	000004	LF3	0003	K	000050
0003	R	000057	M2	0004	R	000044	M1	0004	I	000102	M11	0004	K	000051
0006	R	000001	PC	0004	000065	PRT	0004	000000	Q	0004	K	000057	M2	
0004	000075	HK	0000	K	000065	SLOPE	0004	000066	TAU	0004	000067	R	000627	
										0004	000103	Tbl	000103	Tbl

Figure III-2. Continued.

```

00101 1* SUBROUTINE HARM(S)
00101 2* C
00101 3* C *** NOTE : RETURN 1 GOES TO THE COCHANNEL PATH OF THE CALLING ROUTINE
00101 4* C
00103 5* DIMENSION HAR(10),IB(10)
00104 6* REAL M1,K1,K5,M2,N1,KH,N2,LF,LF1,LF2,LF3
00105 7* INTEGER CCHNL
00106 8* INTEGER H
00107 9* COMMON/MBLOCK/A(32),IF,BR,B(2),M1,F1H,F2H,K1,K5,L0P,C,FI,D(3),M2,
00107 10* *E(17),FA,FB,RBL(140)
00110 11* COMMON/TBLOCK/Q(33),B1T,F(1),ITJ6,N1,F1T,F2T,KH(8),N2,B(3),PRT,
00110 12* *GG(2),TAU,K(3),1PCOMP,FC,FD,RR(4),B2T,N11,TBL(141)
00111 13* COMMON/PBLOCK/AA(19),LF,BB(2),H,PBL(37)
00111 14* C *** THIS COMMON BLOCK IS GENERATED BY UFR
00112 15* COMMON/ZBLOCK/CCHNL,C,LF1,LF2,LF3,DF,DFS,BK,IMAGE,F1P,F2P,DF1,
00112 16* *UF2,DF3,DF4,DF5,DF6,UFFIL1,UFFIL2
00113 17* DIMENSION DFN(10),DEL1(10),DEL2(10)
00114 18* IF(N11-1) 10,10,11
00117 19* 10 DF=AMIN1(ABS(DP1),ABS(OF2))
00120 20* RETURN
00121 21* 11 IF(FC=0.) 8,8,6
00124 22* 6 DO 7 I=2,N11
00127 23* IF((I-1)*F2T-UFIL2) 8,8,7
00132 24* 7 CONTINUE
00134 25* 60 TO 10
00135 26* 8 DO 9 I=1,10
00140 27* DFN(I)=1*F2T-F1P
00141 28* DEL1(I)=1*F1T-F2P
00142 29* DEL2(I)=F1P-1*F2T
00143 30* 9 CONTINUE
00145 31* 00 13 I=2,N11
00150 32* IF(DFN(I)=0.) 13,14,14
00153 33* 13 CONTINUE
00153 34* C *** THE MAXIMUM NUMBER OF HARMONICS TO CONSIDER HAS BEEN REACHED
00155 35* DF=ABS(DEL2(N11))
00156 36* M=N11
00157 37* GO TO 20
00157 38* C *** THE FOLLOWING IS A COARSE CO-CHANNEL TEST
00160 39* 14 IF(DEL1(I).GT.U.)GO TO 15
00162 40* H=1
00163 41* CCHNL=1
00164 42* GO TO 999
00164 43* C *** THIS IS A MORE REFINED TEST TO SEE IF THE LOWER END OF THE TRANSMITTER
00164 44* C *** HARMONIC IS COCHANNEL WITH THE RECEIVER (OR IMAGE)
00165 45* 15 IF(F1P-BM/2.GT.1*F1T.OR.1*F1T.GT.F2P+BM/2) GO TO 16
00167 46* H=1
00170 47* CCHNL=1
00171 48* GO TO 999
00171 49* C *** THIS IS A MORE REFINED TEST TO SEE IF THE UPPER END OF THE TRANSMITTER
00171 50* C *** HARMONIC IS COCHANNEL WITH THE RECEIVER (OR IMAGE)
00172 51* 16 IF(F1P-BM/2.GT.1*F2T.OR.1*F2T.GT.F2P+BM/2) GO TO 17
00174 52* H=1
00175 53* CCHNL=1

```

```

00176 54*      GO TO 999
00176 55*      C *** ONLY A HARMONIC IS PICKED, THIS TEST DETERMINES WHETHER THE NEXT LOWEST
00176 56*      C *** HARMONIC IS CLOSER TO THE RECEIVER (OR IMAGE)
00177 57*      17 IF(DEL1(I).GT.ABS(DEL2(I-1)))GO TO 18
00201 58*      DF=DEL1(I)
00202 59*      M=I
00203 60*      IF(M.EQ.1) GO TO 999
00205 61*      GO TO 20
00205 62*      L *** IF THE NEXT LOWER HARMONIC IS CLOSER, IS IT ALSO CO-CHANNEL?
00206 63*      18 IF(F1P-BM/2.GT.(I-1)*F2T) GO TO 19
00210 64*      M=I-1
00211 65*      LCMNL=1
00212 66*      GO TO 999
00213 67*      19 DF=DEL2(I-1)
00214 68*      M=I-1
00215 69*      IF(M.EQ.1) GO TO 999
00215 70*      C *** AN HARMONIC M HAS BEEN PICKED. THE FOLLOWING CODING IS DESIGNED TO
00215 71*      C *** REMOVE THE ASSUMPTION THAT ALL HARMONIC LEVELS ARE EQUAL BY COMPARING
00215 72*      C *** THE FREQUENCY REJECTION CAUSED BY M-1, M, AND M+1. ANY HARMONIC THAT
00215 73*      C *** IS FOUND TO BE OUT OF BAND IS ELIMINATED FROM FURTHER CONSIDERATION,
00215 74*      C *** REGARDLESS OF ITS LEVEL.
00217 75*      20 DO 21 J=2,M+1
00222 76*      21 HAR(J)=KH(J-I)
00224 77*      HAR(1)=0.
00225 78*      DO 22 K=1,10
00230 79*      22 IB(K)=0
00232 80*      SLOPE=AMIN1(N1,M1)
00233 81*      I LIM=N1+1
00234 82*      DO 12 I=I LIM,10
00237 83*      DEL1(I)=10000.
00240 84*      DEL2(I)=10000.
00241 85*      12 HAR(I)=1000.
00243 86*      J2=H-1
00244 87*      K=H+1
00245 88*      DO 23 I=J,K
00245 89*      C *** THE FOLLOWING TEST DETERMINES WHETHER A HARMONIC IS IN-BAND. IF HARMONIC
00245 90*      C *** N IS IN-BAND, THEN IB(N) IS SET EQUAL TO 1. OTHERWISE IT IS 0.
00250 91*      IF(I*F2T.LT.FA.UR.1+I.T.GT.FB) GO TO 25
00252 92*      IB(I)=1
00253 93*      23 CONTINUE
00255 94*      IF(IB(H-1).EQ.0) GO TO 26
00257 95*      IF(IB(H).EQ.0) GO TO 29
00257 96*      C *** IF THE FOLLOWING TEST IS FALSE, THEN ALL THREE HARMONICS ARE IN-BAND
00261 97*      IF(IB(H+1).EQ.0) GO TO 30
00263 98*      30U1=AMIN1(ABS(DEL1(H-1)),ABS(DEL2(H-1)))
00264 99*      U2=AMIN1(ABS(DEL1(H)),ABS(DEL2(H)))
00265 100*      U3=AMIN1(ABS(DEL1(H+1)),ABS(DEL2(H+1)))
00266 101*      CAL1=-HAR(H-1)-10*SLOPE*ALOG10(U1)
00267 102*      CAL2=-HAR(H)-10*SLOPE*ALOG10(U2)
00270 103*      CAL3=-HAR(H+1)-10*SLOPE*ALOG10(U3)
00271 104*      IF(CAL1.LT.CAL2) GO TO 24
00273 105*      IF(CAL1.LT.CAL3) GO TO 25
00275 106*      M=H-1
00276 107*      DF=D1
00277 108*      GO TO 999

```

Figure III-2. Continued.

```

00300 109*      24 IF (CAL2.LT.CAL3) GO TO 25
00302 110*      UF=U2
00303 111*      GO TO 999
00304 112*      25 M=M+1
00305 113*      UF=D3
00306 114*      GO TO 999
00307 115*      26 IF (IB(H+1).EQ.0) GO TO 27
00311 116*      IF (IB(H).EQ.0) GO TO 28
00311 117*      C *** BOTH H AND H+1 ARE IN-BAND
00313 118*      11=H
00314 119*      12=H+1
00315 120*      U1=AMIN1(ABS(DEL1(H)),ABS(DEL2(H)))
00316 121*      D2=AMIN1(ABS(DEL1(H+1)),ABS(DEL2(H+1)))
00317 122*      GO TO 200
00317 123*      C *** ONLY H IS IN-BAND
00320 124*      27 IF (IB(H).NE.0) GO TO 999
00320 125*      C *** ALL THREE HARMONICS ARE OUT OF BAND.
00322 126*      SLOPE=AMIN1(N2,M2)
00323 127*      GO TO 300
00323 128*      C *** ONLY H+1 IS IN BAND
00324 129*      28 M=H+1
00325 130*      IF (H.GT.N11) M=H-1
00327 131*      UF=AMIN1(ABS(DEL1(H)),ABS(DEL2(H)))
00330 132*      GO TO 999
00330 133*      C *** AN ERROR HAS OCCURRED IF IT IS FOUND THAT ONLY H-1 AND H+1 ARE IN-BAND.
00331 134*      29 IF (IB(H+1).EQ.1) RETURN 0
00331 135*      C *** ONLY H-1 IS IN-BAND
00333 136*      M=H-1
00334 137*      DF=AMIN1(ABS(DEL1(H-1)),ABS(DEL2(H-1)))
00335 138*      GO TO 999
00335 139*      C *** BOTH H-1 AND H ARE IN-BAND
00336 140*      30 11=H
00337 141*      12=H-1
00340 142*      D1=AMIN1(ABS(DEL1(H)),ABS(DEL2(H)))
00341 143*      U2=AMIN1(ABS(DEL1(H-1)),ABS(DEL2(H-1)))
00342 144*      200 CAL1=-HAR(11)-10*SLOPE*ALOG10(O1)
00343 145*      CAL2=-HAR(12)-10*SLOPE*ALOG10(O2)
00344 146*      IF (CAL1.LT.CAL2) GO TO 31
00346 147*      H=11
00347 148*      UF=D1
00350 149*      GO TO 999
00351 150*      31 M=12
00352 151*      UF=D2
00353 152*      999 IF (FC=0.) 1000,1000,998
00356 153*      998 DO 997 1=H+1,-1
00361 154*      IF ((1-1)*F2T-OFF1L2) 996,996,997
00364 155*      997 CONTINUE
00366 156*      996 IF (1.EQ.H.AND.CCHNL.EQ.1) RETURN1
00370 157*      M=1
00371 158*      UF=AMIN1(ABS(DEL1(H)),ABS(DEL2(H)))
00372 159*      RETURN
00373 160*      1000 IF (CCHNL.EQ.1) RETURN1
00375 161*      RETURN
00376 162*      END

```

Figure III-2. Continued.

HARM CODE SYMBOLIC RELOCATABLE
 0 *DIAGNOSTIC* MESSAGE(S)
 20 NOV 70 16:50:00 U 01577702 10 10X (DELETED-01)
 15 DEC 70 06:10:42 U 01586706 30 1 (DELETED)
 01587022 10 00

SURROUTINE POKEN ENTRY POINT 000302
 STORAGE USED (BLOCK, NAME, LENGTH...)
 0001 *CODE 000304
 0000 *DATA 000025
 0002 *BLANK 000000
 0003 *BLOCK 000317
 0004 *BLOCK 000320
 0005 *BLOCK 000074
 0006 *BLOCK 000024

EXTERNAL REFERENCES (BLOCK, NAME)

0007 EXTRAC
 0010 ALOGIO
 0011 NEAP45
 0012 NERN35

STORAGE ASSIGNMENT FOR VARIABLES (BLOCK, TYPE, RELATIVE LOCATION, NAME)

0001	000166	IOL	0001	000224	ZOL	0001	000252	ZOL	0001	000240	ZOL	0001	000043	ZOL	
0001	000113	91L	0001	000134	92L	0001	000153	94L	0001	000273	999L	0003	000000	A	
0005	000000	AA	0003	000042	B	0005	000024	BB	0006	000007	BM	0003	000041	BR	
0004	R	000041	BIT	000101	W2T	0003	000052	C	0006	I	000000	CCMML	0003	000054	O
0006	000005	OF	0006	000021	OFFIL1	0006	000022	OFFIL2	0006	000006	OFF5	0006	000013	OFF1	
000A	000014	UF2	0006	000015	PF3	0006	000016	OF4	0006	000017	OF5	0006	000020	OF6	
0000	K	000005	OPC	000060	E	0003	I	000000	EXTRAC	0004	000042	F	0003	000101	FA
0003	000102	FB	0004	000073	FC	0004	000074	FD	0003	U	00053	FI	0003	000040	FIF
0006	000011	FIP	0003	000045	FIN	0004	000045	FII	0006	000012	F2P	0003	000046	F2R	
0004	000046	F2T	0004	000060	G	0004	000064	GG	0005	I	000026	M	0006	000010	IMAGE
0000	000015	INJPS	0000	I	000000	IP	0004	I	000072	IPCOMP	0000	I	000003	IPULSE	
0004	I	000043	I136	0000	I	000004	JPULSE	0004	R	000047	KI	0003	K	000050	K5
0005	R	000023	LF	0006	K	000002	LF1	0006	R	000003	LF2	0006	R	000051	LOP
0003	R	000044	MI	0003	R	000057	M2	0004	R	000044	MI	0004	K	000057	M2
0005	000027	FBL	0006	R	000001	PC	0000	R	000002	PI	0004	R	000063	PRT	
0004	000000	Q	0004	000067	R	0003	000103	RUL	0004	000075	RR	0004	R	000064	TAU
0004	000103	Tbl													

0-101 10 SURROUTINE POKEN
 00103 20 REAL MI,K1,K3,M2,M1,KH,M2,LF,LP1,LP2,LF3
 00104 30 INTEGER CCMML
 00105 40 INTEGER M

Figure III-2. Continued.

```

0010A 50      INTEGER EATHAC
00107 A0      COMMON/NBLOCK/A(132),F1,F,HR,B(2),N1,F1H,FZR,K1,KS,LOP,C,F),O(3),M2,
00107 70      *E(17),FA,FB,KML(140)
00110 80      COMMON/TBLOCK/T(33),B(1,F)),IT36,NE,FIT,F2T,KH(B),N2,G(3),PRT,
00110 90      *GG(2),TAU,R(1),IPCOMP,PC,PO,RR(4),B2T,N(1),TBL(14)
00111 100     COMMON/PBLOCK/A(197),LT,BB(2),H,PML(37)
00111 110     C *** THIS COMMON BLOCK IS GENERATED BY OFR
00112 120     COMMON /ZBLOCK/CCHNL,PC,LF1,LF2,LF3,OF,OF5,BH,INAME,F1P,F2P,OF1,
00112 130     *OF2,OF3,OF4,OF5,OF6,OFFIL1,OFFIL2,P1
00113 140     DATA JP/1HP/1P1/LHC/
00114 150     DATA P1/3.1415927/
00120 160     JPULSE=EXTRAC(1)T3A,1)
00121 170     JPULSE=EXTRAC(1)T36,2)
00122 180     PC=0.
00123 190     IF(1)PCOMP,NE,IP) GO TO 10
00123 200     C *** THE EQUIPMENT IS PULSE COMPRESSION
00125 210     IF(CCHNL=NE) GO TO 90
00127 220     IF(BH=BR*TAU/B)T=.) 30,999,999
00132 230     30 PC=10*ALOG(0)BH*TAU/BIT)
00133 240     GO TO 999
00134 250     90 IF(BIT/2=LT=1/1P)*PRT) GO TO 91
00136 260     OPC=10*ALOG(0)BIT*TAU*1PRT/TAU)**P)*(2/(P1*BIT*PH))**.N2)
00137 270     GO TO 92
00140 280     91 OPC=10*ALOG(0)BIT*TAU*1/2/1P1*BIT*TAU)**P)
00141 290     92 IF(BR=TAU=1.) 93,93,94
00144 300     93 PC=10*ALOG(0)BR*TAU) + DPC
00145 310     GO TO 999
00146 320     94 PC=10*ALOG(0)BR*TAU/2) + OPC
00147 330     GO TO 999
00150 340     10 IF(1)PULSE=NE,IP,AND*JPULSE=NE,IP) GO TO 40
00150 350     C *** THE EQUIPMENT IS PULSEO
00152 360     IF(CCHNL=NE) 1 GO TO 20
00154 370     IF(BR=TAU=1.) 50,999,999
00157 380     50 PC=20*ALOG(0)BR*TAU)
00160 390     GO TO 999
00161 400     20 IF(BR=TAU=1.) 60,60,70
00164 410     60 PC=10*ALOG(0)BR*TAU)
00165 420     GO TO 999
00166 430     70 PC=10*ALOG(0)BR*TAU/2)
00167 440     GO TO 999
00167 450     C *** THE EQUIPMENT IS NEITHER PULSEO NOR PULSE COMPRESSION
00170 460     40 IF(CCHNL=NE) GO TO 999
00172 470     IF(BH=B)T) 80,999,999
00175 480     80 PC=10*ALOG(0)BR/BIT)
0017A 490     999 RETURN
00177 500     END

```

Figure III-2. Continued.

APPENDIX IV**AVPAK PROGRAM**

The flow diagrams and FORTRAN V program listing for the overall AVPAK interference prediction program are contained in this Appendix. The flow diagram is shown in Figure IV-1, and the program listing is shown in Figure IV-2.

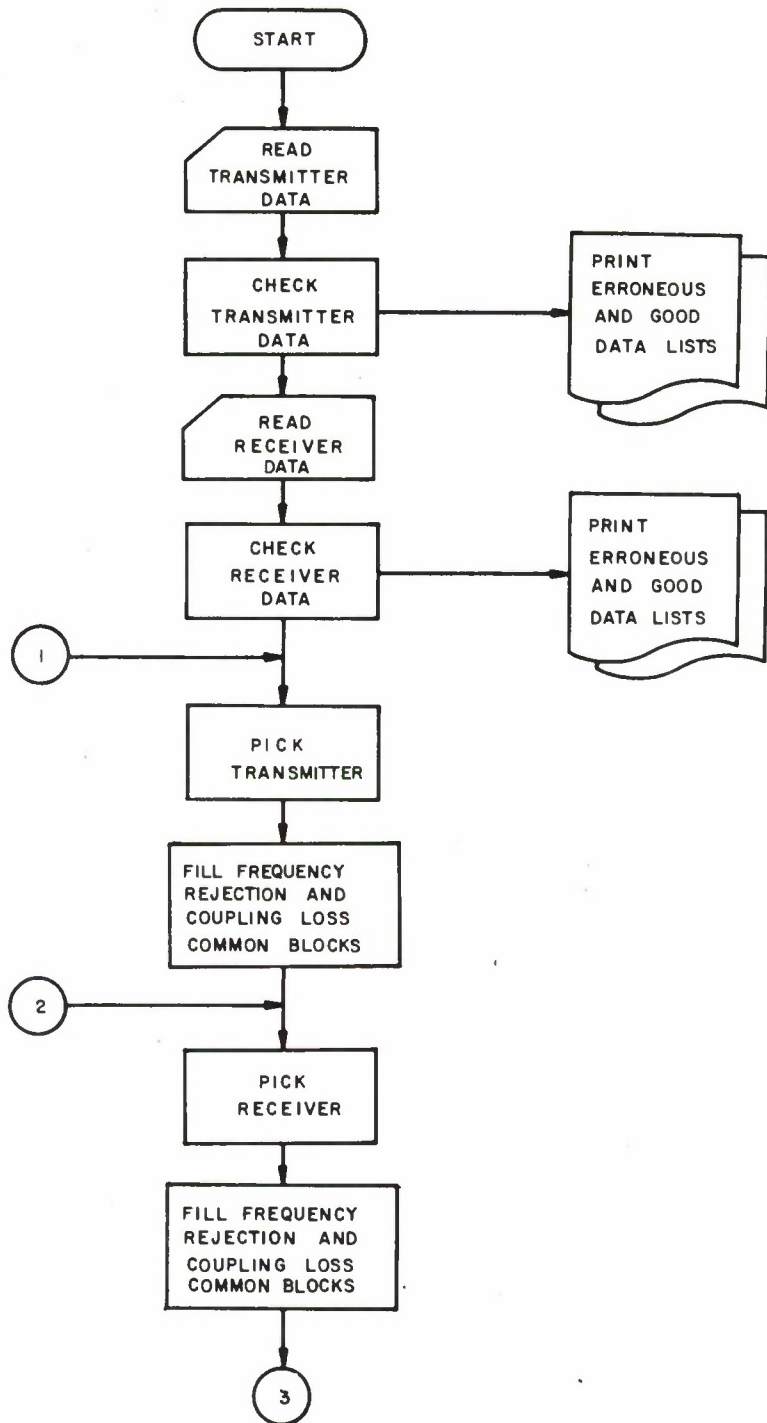

Figure IV-1. AVPAK Flow Diagram.

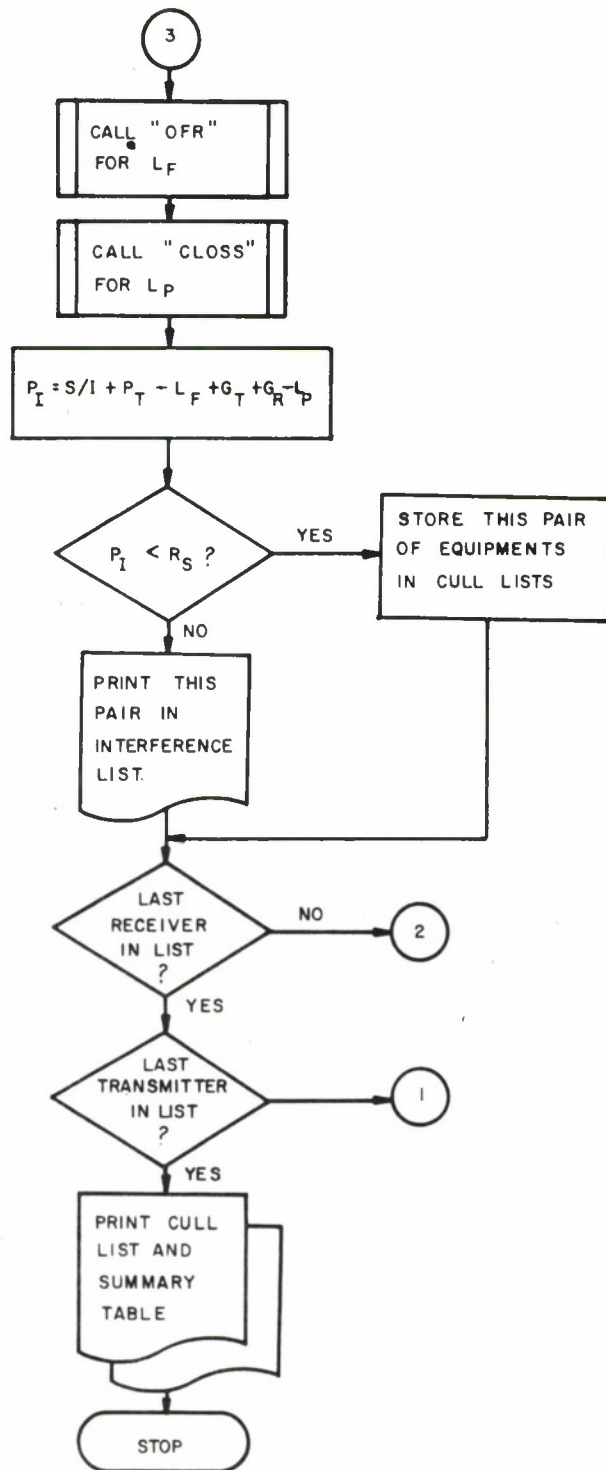

Figure IV-1. Continued.

```

0000 040401 1990F 0001 000324 200L 0001 000343 210L 0001 000362 220L 0001 000166 224G
0001 000401 230L 0001 000417 240L 0001 000436 250L 0001 000455 260L 0001 000474 270L
0001 000511 280L 0001 000527 290L 0001 000555 300L 0001 000574 310L 0001 000614 320L
0001 000631 340L 0001 000647 350L 0001 000665 360L 0001 000703 365L 0001 000721 370L
0001 000737 390L 0001 000747 400L 0001 001075 410L 0001 001079 420L 0001 001103 500L
0001 001134 540L 0001 000772 542G 0001 001001 550G 0001 001010 556G 0001 001035 573G
0001 001134 600L 0001 001066 605G 0001 001361 610L 0001 001376 620L 0001 001126 627G
0001 001462 660L 0001 001150 635G 0001 001361 610L 0001 001160 642G 0001 001445 650L
0001 001563 695L 0001 001600 697L 0001 001514 690L 0001 001531 695L 0001 001544 698L
0001 002256 780L 0001 002344 800L 0001 001615 700L 0001 001625 710L 0001 000201 74L
0001 002556 820L 0001 002560 821L 0001 002457 805L 0001 002472 810L 0001 002502 815L
0006 K 000003 ANGLE 0006 K 000005 ANTH 0001 002221 87L 0001 002737 910L 0001 002744 990L
0006 000014 CURVE 0006 K 000001 C1ST 0000 R 043264 BLANK 0006 R 000014 BULK 0000 R 001750 CIRL
0006 000615 FREE 0006 K 000001 C1ST 0006 I 000017 ERK 0007 I 000000 EXTRAC 0006 R 000011 FHR
0000 R 043261 NHARM 0000 I 037213 I 0006 R 000000 FREQ 0006 R 000000 FREQ 0000 P 037227 GP 0000 R 037224 CT
0000 I 037204 IC 0000 I 037213 I 0000 I 037202 1A 0000 I 037203 1B 0000 I 037204 1C 0000 I 043264 1RLA1Y
0000 I 037225 IREC 0000 I 043256 1D1 0000 I 043257 1D2 0000 I 037207 1P 0000 I 037201 1P 0000 I 043264 1RLA1Y
0000 I 040404 1TX 0000 I 037233 1T1 0000 I 043263 1R2 0000 I 043263 1R2 0003 I 000000 1TR 0000 I 037221 1TRAN
0000 I 037214 J 0000 I 037212 K 0006 000017 KERP 0000 I 037206 1X 0000 I 037205 1Y 0000 I 043260 1OP
0000 I 037216 M 0000 I 037217 MCULL 0000 I 043261 NHARM 0000 I 037218 L 0000 I 037210 1T 0000 I 037210 1T
0000 K 037232 PI 0000 A 037235 1TRAN1 0000 A 037236 1TRAN2 0000 I 037220 NWRITE 0000 R 037231 CFREJ 0005 R 000000 PRL
0004 R 000000 RBL 0000 K 043256 RID1 0000 K 037233 PT 0000 I 032274 PIEST 0006 I 000007 RANT 0006 R 000012 PR
0000 R 000000 RX 0000 K 043262 R1 0000 K 043256 RID2 0000 R 043260 RLOP 0000 R 037226 FS
0006 R 000016 TCOUP 0000 I 032275 TOTAL 0000 R 040404 TX 0000 R 037230 SI

```

```

00101 1* DIMENSION TX(51,29),RX(50,20),ITX(50,29),ITR(47),CJLL(5,2500)
00103 2* I=I/SELR RANT,ERR,PTEST,FXTIAC,TOTAL(50,50)
00104 3* COMMON/TBLOCK/THL(67)/PBLOCK/RRL(67)/PBLOCK/PHL(23)
00105 4* COMMON/CLCOMM/FREQ/DIST(2),ANGLE(2),ANTHT(2),PANT(?),
00105 5* FMB*RB*BULK*CURVE*FREE,TCOUP*KERR
00106 6* EQUIVALENCE (TX(1,1),ITX(1,1)),(TR(1,1),ITH(1,1))
00110 7* EQUIVALENCE (I(1,1),RID1),(I(2,1),RIF2),(L(1),RLOK),(NHAR*HAPM)
00110 8* EQUIVALENCE (I(1,1),R1),(I(2,1),R2),(RLA1K,1RLA1K),(ERP*KERR)
00111 9* DATA IBLA1K,IP,IA,IB,IC,1H,1HP,1HA,1HR,1HC/
00117 10* DATA TOTAL/2500*1H /1X,1H/1HX,1HW/
00123 11* CALL INTRUP(0)
00124 12* HEAD(5,1000)IT,IP,FMB*PR
00132 13* 1000 FOMAT(2(12,3),2(F6,0,4X))
00133 14* IF(INT,LT,1)GO TO 410
00135 15* K=1
00135 16* C
00135 17* C**
00135 18* C
00136 19* *KTIL(6,10/5)
00140 20* FOMAT(1H)
00141 21* GO 400 I=1,MT
00144 22* K=AD(5,101)IT,(K+1),ITX(K+2),(TX(K+2),J=3,10),IT(K+11),ITX(K+12)
00144 23* ,(TX(K+2),J=13,15),ITX(K+20),ITX(K+21),ITX(K+J),J=22,20)
00170 24* 1010 FOMAT(2A6,2(14F4,0),2(14F4,0),2(14F4,0),14F3,0,14F4,0,14X3,1X1,
00170 25* 2(14F4,0),4(6,0,1F),4(5,0,14F4,0,2(11Y11)),2(14F4,0))

```

Figure IV-2. AVPAK Program Listing.

```

00171 26*      NHARM=ITX(K,21)
00172 27*      IF(ITX(K,3))210,210,25
00175 28*      25 IF(ITX(K,4))220,220,35
00200 29*      35 IF(ITX(K,4)-TX(K,3))230,50,50
00203 30*      50 IF(ITX(K,5))240,240,55
00206 31*      55 IF(ITX(K,6))250,250,60
00211 32*      60 IF(ITX(K,6)-TX(K,5))260,65,65
00214 33*      65 IF(ITX(K,7).LT,20.)GO TO 270
00216 34*      IF(ITX(K,8).LT,20.)GO TO 280
00220 35*      IF(NHARM-1)200,73,68
00223 36*      68 DO 70 J=2,NHARM
00226 37*      70 IF(ITX(K,J+20).LT,0.)GO TO 290
00231 38*      73 IF(ITX(K,15))300,87,80
00234 39*      80 IF(ITX(K,16))310,310,85
00237 40*      85 IF(ITX(K,16).LT,IX(K,15))GO TO 320
00241 41*      87 PTEST=EXTRAC(ITX(K,11),1)
00242 42*      IF(PTEST.NE,1)GO TO 115
00244 43*      IF(ITX(K,11).EQ,IBLANK)GO TO 110
00246 44*      IF(ITX(K,12).EQ,IBLANK)GO TO 107
00250 45*      IF(ITX(K,12).NE,1C)GO TO 340
00252 46*      IF(ITX(K,13)-TX(K,14))360,360,105
00255 47*      105 IF(ITX(K,14))360,360,107
00260 48*      107 IF(ITX(K,13))350,350,110
00263 49*      110 IF(ITX(K,12).NE,1C)GO TO 115
00265 50*      IF(ITX(K,5)*TX(K,13)-1.)365,365,115
00270 51*      115 FREQ=(TX(K,3)+TX(K,4))/2.
00271 52*      IF(FREQ-30.)370,390,390
00271 53*      C
00271 54*      C** TRANSMITTER DATA NOT GOOD. WRITE ERROR MESSAGES AND SKIP THIS EQUIPMENT.
00271 55*      C
00274 56*      200 WRITE(6,1200)ITX(K,1),ITX(K,2)
00300 57*      1200 FORMAT('0THANS-ITTER ',2A6,' HAS BEEN SKIPPED.')
```

```

00301 58*      WRITE(6,1205)NHARM
00304 59*      1205 FORMAT(10X30HILLEGAL NUMBER OF HARMONICS = ,I1)
00305 60*      GO TO 400
00306 61*      210 WRITE(6,1200)ITX(K,1),ITX(K,2)
00312 62*      WRITE(6,1210)IX(K,3)
00315 63*      1210 FORMAT(10X31HIX PRI FREQUENCY IS IN ERROR: ,F8.0)
00316 64*      GO TO 400
00317 65*      220 WRITE(6,1200)ITX(K,1),ITX(K,2)
00323 66*      WRITE(6,1220)IX(K,4)
00326 67*      1220 FORMAT(10X31HIX SEC FREQUENCY IS IN ERPOP: ,F8.0)
00327 68*      GO TO 400
00330 69*      230 WRITE(6,1200)ITX(K,1),ITX(K,2)
00334 70*      WRITE(6,1230)
00336 71*      1230 FORMAT(10X43HIX SEC FREQUENCY LESS THAN TX PRI FPLQUENCY)
00337 72*      GO TO 400
00340 73*      240 WRITE(6,1240)ITX(K,1),ITX(K,2)
00344 74*      WRITE(6,1240)IX(K,5)
00347 75*      1240 FORMAT(10X29HIX PRI BANDWIDTH INCORRECT: ,F8.0)
00350 76*      GO TO 400
00351 77*      250 WRITE(6,1200)ITX(K,1),ITX(K,2)
00355 78*      WRITE(6,1250)IX(K,6)
00360 79*      1250 FORMAT(10X29HIX SEC BANDWIDTH INCORRECT: ,F8.0)
00361 80*      GO TO 400
```

Figure IV-2. Continued.

```

00362 81* 200 WRITE(6,1200)ITX(K,1),ITX(K,2)
00366 82* WRITE(6,1260)
00370 83* 1260 FORMAT(10X36H1X SEC BANDWIDTH LESS THAN TX PRI BW)
00371 84* GO TO 400
00372 85* 270 WRITE(6,1200)ITX(K,1),ITX(K,2)
00376 86* WRITE(6,1270)
00400 87* 1270 FORMAT(10X29H1X PRI SPEC FALLOFF TOO SMALL)
00401 88* GO TO 400
00402 89* 280 WRITE(6,1200)ITX(K,1),ITX(K,2)
00406 90* WRITE(6,1280)
00410 91* 1280 FORMAT(10X29H1X SEC SPEC FALLOFF TOO SMALL)
00411 92* GO TO 400
00412 93* 290 WRITE(6,1200)ITX(K,1),ITX(K,2)
00416 94* WRITE(6,1290)J,ITX(K,J*20)
00422 95* 1290 FORMAT(10X15HARMONIC LEVEL *11,29H MUST BE GREATER THAN ZERO:
00423 96* F5.0)
00423 97* GO TO 400
00424 98* 300 WRITE(6,1200)ITX(K,1),ITX(K,2)
00430 99* WRITE(6,1300)ITX(K,15)
00433 100* 1300 FORMAT(10X31HFILTER LOWER LIMIT INCORRECT: *F8.0)
00434 101* GO TO 400
00435 102* 310 WRITE(6,1200)ITX(K,1),ITX(K,2)
00441 103* WRITE(6,1310)ITX(K,16)
00444 104* 1310 FORMAT(10X31HFILTER UPPER LIMIT INCORRECT: *F8.0)
00445 105* GO TO 400
00446 106* 320 WRITE(6,1200)ITX(K,1),ITX(K,2)
00452 107* WRITE(6,1320)
00454 108* 1320 FORMAT(10X34HFILTER UPPER LIMIT LESS THAN LOWER)
00455 109* GO TO 400
00456 110* 340 WRITE(6,1200)ITX(K,1),ITX(K,2)
00462 111* WRITE(6,1340)
00464 112* 1340 FORMAT(10X37HPULSE COMPRESSION INDICATOR INCORRECT)
00465 113* GO TO 400
00466 114* 350 WRITE(6,1200)ITX(K,1),ITX(K,2)
00472 115* WRITE(6,1350)
00474 116* 1350 FORMAT(10X37HPULSE WIDTH MUST BE GREATER THAN ZERO)
00475 117* GO TO 400
00476 118* 360 WRITE(6,1200)ITX(K,1),ITX(K,2)
00502 119* WRITE(6,1360)
00504 120* 1360 FORMAT(10X46HPULSE RISE TIME MUST BE GT 0 AND LT PULSEWIDTH)
00505 121* GO TO 400
00506 122* 365 WRITE(6,1200)ITX(K,1),ITX(K,2)
00512 123* WRITE(6,1365)
00514 124* 1365 FORMAT(10X73H PRI BANDWIDTH * PULSEWIDTH MUST BE GT 1 FOR PULSE CO
00514 125* MPRESSION EQUIVMENTS)
00515 126* GO TO 400
00516 127* 370 WRITE(6,1200)ITX(K,1),ITX(K,2)
00522 128* WRITE(6,1370)
00524 129* 1370 FORMAT(10X31HFILTER FREQUENCIES TOO LOW)
00525 130* GO TO 400
00526 131* 390 K=K+1
00527 132* IF(K.GT.50)GO TO 410
00531 133* 400 CONTINUE
00533 134* K=K-1
00534 135* IF(K.EQ.0)GO TO 410

```

Figure IV-2. Continued.

```

00536 136*      WRITE(6,1403)
00540 137* 1403 FORMAT(1H1,50X,TRANSMITTERS WITH GOOD DATA//O*TRANSMITTER LOW FREQ
00540 138* .0 H1 FREQ Bw1 HW2 SF1 SF2 PT GT MT PCI Pw PRT LO
00540 139* .W FILT HI FILT Z-DIST HEIGHT ANGLE R W/14X6(1H.)'(MHZ)'.
00540 140* . 6(1H.)' ... (KHZ)... ..(DB/DFC).. ... (DB)... ..(US)..
00540 141* . ....(MHZ)..... (IN) (FT) (DEG)'/)
00541 142*      DO 405 I=1,K
00544 143*      WRITE(6,1405)ITX(I,1),ITX(I,2),(TX(I,J),J=1,10),ITX(I,11),ITX(I,12
00544 144* .), (TX(I,J),J=13,19),ITX(I,20),ITX(I,21),
00544 145* 1405 FORMAT(1X2A6,2F9.0,2F7.0, 4F6.0, A3,1XA1, F5.1,1XF4,2,2F9.0,FA.
00544 146* .1,F7,2,3XF5,0,2(1X11))
00545 147*      405 CONTINUE
00567 148*      WRITE(6,1415)
00571 149* 1415 FORMAT('/',25X,TRANSMITTER HARMONICS//?1X1H2,10X1H3,10X1H4,10X1H5,
00571 150* . 10X1H6,10X1H7,10X1H8,10X1H9//)
00572 151*      DO 420 I=1,K
00575 152*      NHARM=ITX(I,21)
00576 153*      IF(NHARM.LE.1)GO TO 420
00600 154*      NHARM=NHARM*20
00601 155*      WRITE(6,1420)ITX(I,1),ITX(I,2),(TX(I,J),J=22,1,HARM)
00611 156* 1420 FORMAT(1H ,2A6,8F11.0)
00612 157*      420 CONTINUE
00614 158*      GO TO 500
00615 159*      410 WRITE(6,1410)
00617 160* 1410 FORMAT(3#NUMBER OF TRANSMITTERS IS ILLEGAL)
00620 161*      GO TO 990
00621 162*      500 L=1
00621 163*
00621 164* C
00621 165* C** READ AND CHECK RECEIVER DATA
00622 166* C
00624 167*      IF(NH.LT.1)GO TO 910
00626 168*      WRITE(6,1005)
00631 169*      DO 710 I=1,NR
00646 170* 1500 READ(5,1500)ID1, ID2, (RX(L,J),J=3,12),LOP, (RX(L,J),J=14,20)
00646 171* . F6.0,1XF5.0,1XF4.0,1XF1.0,1XF5.0,2(1XF8.0),1XA1/
00647 172*      IF(RX(L,3))600,600,505
00652 173* 505 IF(RX(L,3).GT.99999.)GO TO 600
00654 174*      IF(RX(L,4))610,610,510
00657 175* 510 IF(RX(L,4).GT.99999.)GO TO 610
00661 176*      IF(RX(L,4).LT.1)X(L,3)GO TO 620
00663 177*      IF(RX(L,5))630,630,515
00666 178* 515 IF(RX(L,6))640,640,516
00671 179* 516 IF(RX(L,6).GT.99999.)GO TO 640
00673 180*      IF(RX(L,7).LT.20)GO TO 650
00675 181*      IF(RX(L,8).LT.20)GO TO 660
00677 182*      IF(RX(L,9).LT.0)GO TO 670
00701 183*      IF(RX(L,10).LT.0)GO TO 680
00703 184*      IF(RX(L,11))625,625,520
00706 185* 520 IF(RX(L,11).GT.99999.)GO TO 625
00710 186*      IF(RX(L,12))69,69,525
00713 187* 525 IF(RX(L,12).GT.99999.)GO TO 690
00715 188*      IF(RX(L,12)-RX(L,11))605,530,530
00720 189* 530 IF(LOP.EQ.1A)GO TO 540
00722 190*      IF(LOP.EQ.1B)GO TO 540

```

Figure IV-2. Continued.

```

00724 191*      IF(LOP.NE.IC)GO TO 697
00726 192*      540 RX(L,1)=RID1
00727 193*      RX(L,2)=RID2
00730 194*      RX(L,13)=RLOP
00731 195*      GO TO 700
00731 196*      C
00731 197*      C** RECEIVER DATA NOT GOOD. WRITE ERROR MESSAGES AND SKIP THIS EQUIPMENT.
00731 198*      C
00732 199*      600 WRITE(6,1600)ID1,IO2
00736 200*      1600 FORMAT('RECEIVER ',2A6,' HAS BEEN SKIPPED.')
00737 201*      WRITE(6,1605)
00741 202*      1605 FORMAT(10X46HXX PRI FREQ MUST BE BETWEEN ZERO AND 99999 MHZ)
00742 203*      GO TO 710
00743 204*      610 WRITE(6,1600)ID1,IO2
00747 205*      WRITE(6,1610)
00751 206*      1610 FORMAT(10X46HXX SEC FREQ MUST BE BETWEEN ZERO AND 99999 MHZ)
00752 207*      GO TO 710
00753 208*      620 WRITE(6,1600)ID1,IO2
00757 209*      WRITE(6,1620)
00761 210*      1620 FORMAT(10X33HXX SEC FREQ LESS THAN RX PRI FREQ)
00762 211*      GO TO 710
00763 212*      630 WRITE(6,1600)ID1,IO2
00767 213*      WRITE(6,1630)
00771 214*      1630 FORMAT(10X38HXX BANDWIDTH MUST BE GREATER THAN ZERO)
00772 215*      GO TO 710
00773 216*      640 WRITE(6,1600)ID1,IO2
00777 217*      WRITE(6,1640)
01001 218*      1640 FORMAT(10X50HXX INTERMEDIATE FREQ MUST BE GT ZERO AND LE 99999 MHZ)
01002 219*      GO TO 710
01003 220*      650 WRITE(6,1600)ID1,IO2
01007 221*      WRITE(6,1650)
01011 222*      1650 FORMAT(10X33HXX PRI SPEC FALLOFF MUST BE GE 20)
01012 223*      GO TO 710
01013 224*      660 WRITE(6,1600)ID1,IO2
01017 225*      WRITE(6,1660)
01021 226*      1660 FORMAT(10X33HXX SEC SPEC FALLOFF MUST BE GE 20)
01022 227*      GO TO 710
01023 228*      670 WRITE(6,1600)ID1,IO2
01027 229*      WRITE(6,1670)
01031 230*      1670 FORMAT(10X27HXX IMAGE LEVEL MUST BE GE ZERO)
01032 231*      GO TO 710
01033 232*      680 WRITE(6,1600)ID1,IO2
01037 233*      WRITE(6,1680)
01041 234*      1680 FORMAT(10X30HXX SPURIOUS LEVEL MUST BE GE ZERO)
01042 235*      GO TO 710
01043 236*      685 WRITE(6,1600)ID1,IO2
01047 237*      WRITE(6,1685)
01051 238*      1685 FORMAT(10X51HXX LOWER OPER FREQ MUST BE GT ZERO AND LE 99999 MHZ)
01052 239*      GO TO 710
01053 240*      690 WRITE(6,1600)ID1,IO2
01057 241*      WRITE(6,1690)
01061 242*      1690 FORMAT(10X51HXX UPPER OPER FREQ MUST BE GT ZERO AND LE 99999 MHZ)
01062 243*      GO TO 710
01063 244*      695 WRITE(6,1600)ID1,IO2
01067 245*      WRITE(6,1695)

```

Figure IV-2. Continued.

```

01071 246* 1695 FORMAT(10X37HXX UPPER OPER FREQ LT LOWER OPER FREQ)
01072 247* GO TO 710
01073 248* 697 WRITE(6,1600)101,102
01077 249* WRITE(6,1697)
01101 250* 1697 FORMAT(10X44HLOCAL OSCILLATOR POSITION MUST BE A, H, OR C)
01102 251* GO TO 710
01103 252* 700 L=L+1
01104 253* IF(L.GT.50)GO TO 910
01106 254* 710 CONTINUE
01110 255* L=L-1
01111 256* IF(L.LE.0)GO TO 910
01113 257* WRITE(6,1710)
01115 258* 1710 FORMAT(' ',50X'RECEIVERS WITH GOOD DATA'/'0 RECEIVER LOW FREQ H
01115 259* .I FREQ BW IF SF1 SF2 IM LEV SP LEV LOW SRL H1 SRL LOP
01115 260* . Z-DIST HT ANG R SENS GAIN S/I'/13X'.....(MHZ)..... (
01115 261* .KHZ)(MHZ) .(DB/DEC) . ....(DB)..... .....(MHZ)..... (
01115 262* .FT) (DEG) .....(DB).....(IN) (
01116 263* DO 715 I=1,L
01121 264* M=RX(I,17)
01122 265* RID1=RX(I,1)
01123 266* RID2=RX(I,2)
01124 267* RLOP=RX(I,13)
01125 268* 715 WRITE(6,1715)I,1,102,(RX(I,J),J=3,12),LOP,(RX(I,J),J=14,16),
01125 269* M,(RX(I,J),J=18,20)
01150 270* 1715 FORMAT(1X2A6,2F9.0, 3F6.0,3(1XF6.0),2F9.0,1XA1,F7.1,F6.2,
01150 271* F6.0,1X11,3F7.1)
01150 272*
01150 273* C** BEGIN ANALYSIS
01150 274* C
01151 275* NCULL=0
01152 276* NWRITE=3
01153 277* WRITE(6,1740)IT,IR,FNB,RB
01161 278* 1740 FORMAT('1 NUMBER OF TRANSMITTEPS NUMBER OF RECEIVERS KNIFE EDG
01161 279* .E LOCATION(INCHES) KNIFE EDGE HEIGHT(FEET)'/11X12,21X12,22XF7.1
01161 280* . ,20XF7.2)
01162 281* FNB=FNB/12.
01163 282* WRITE(6,1795)
01165 283* 1795 FORMAT(
01165 284* .N GREATER THAN RECEIVER SENSITIVITY))
01166 285* WRITE(6,1809)
01170 286* DO 800 I=1,K
01173 287* WRITE(6,1793)
01175 288* 1793 FORMAT(1H )
01176 289* NWRITE=NWRITE+1
01177 290* I01=ITX(I,1)
01200 291* I02=ITX(I,2)
01201 292* CALL MOVECH(I01,I,2,1TPAN,I)
01202 293* T0L(38)=TX(I,3)
01203 294* T0L(39)=TX(I,4)
01204 295* T0L(34)=TX(I,5)/1000.
01205 296* T0L(66)=TX(I,6)/1000.
01206 297* T0L(37)=TX(I,7)
01207 298* T0L(48)=TX(I,8)
01210 299* IT(36)=ITX(I,11)
01211 300* IT(59)=ITX(I,12)

```

Figure IV-2. Continued.

```

01212 301*      TBL(55)=TX(I,13)
01213 302*      TBL(52)=TX(I,14)
01214 303*      TBL(60)=TX(I,15)
01215 304*      TBL(61)=TX(I,16)
01216 305*      TBL(67)=TX(I,21)
01217 306*      FREQ=(TBL(38)+TBL(39))/2.
01220 307*      U1ST(1)=TX(I,17)/12.
01221 308*      ANHT(1)=TX(I,18)
01222 309*      ANGLE(1)=TX(I,19)
01223 310*      RANT(1)=TX(I,20)
01224 311*      PT=TX(I,9)
01225 312*      GT=TX(I,10)
01226 313*      DO 750 M=22,29
01231 314*      750 TBL(M+18)=TX(I,M)
01233 315*      DO 800 J=1,L
01236 316*      R1=RX(J,1)
01237 317*      R2=RX(J,2)
01240 318*      CALL MOVECH(1R1,1,2,IREC,1)
01241 319*      IF (ITRAN.EQ.IREC)GO TO 800
01243 320*      RBL(38)=RX(J,3)
01244 321*      RBL(39)=RX(J,4)
01245 322*      RBL(34)=RX(J,5)/1000.
01246 323*      RBL(33)=RX(J,6)
01247 324*      RBL(37)=RX(J,7)
01250 325*      RBL(48)=RX(J,8)
01251 326*      RBL(40)=RX(J,9)
01252 327*      RBL(41)=RX(J,10)
01253 328*      RBL(66)=RX(J,11)
01254 329*      RBL(67)=RX(J,12)
01255 330*      RBL(42)=RX(J,13)
01256 331*      DIST(2)=RX(J,14)/12.
01257 332*      ANHT(2)=RX(J,15)
01260 333*      ANGLE(2)=RX(J,16)
01261 334*      RANT(2)=RX(J,17)
01262 335*      RS=RX(J,18)
01263 336*      GR=RX(J,19)
01264 337*      SI=RX(J,20)
01265 338*      CALL OFR
01266 339*      OFREJ=PBL(20)
01267 340*      HARM=PBL(23)
01270 341*      FREQ=FLUAT(NHARM)*FREQ
01271 342*      CALL CLUSS
01272 343*      P1=S1+PT+OFREJ+GT+GR+TCOUP
01273 344*      IF (P1-R5)760,760,780
01276 345*      760 NCULL=NCULL+1
01277 346*      CULL(1,NCULL)=ERR
01300 347*      CALL PACK(CULL(2,NCULL),1+J*50,N,HARM)
01301 348*      CULL(3,NCULL)=OFREJ
01302 349*      CULL(4,NCULL)=TCOUP
01303 350*      CULL(5,NCULL)=BULK
01304 351*      GO TO 800
01305 352*      780 WRITE(6,1780)101,102,IR1,IR2,S1,GT,OFREJ,GT,GR,TCOUP,P1,RS
01323 353*      1780 FORMAT(2(1X,2A6),2X4('F5.0' + '),F5.0, - ',F5.0, = ',F5.0,
01323 354*      .      8XF5.0)
01324 355*      CALL MSG(NHARM)

```

Figure IV-2. Continued.

```

01325 356*      TOTAL(I,J)=IX
01326 357*      NWRITE=NWRITE+1
01327 358*      ID1=IBLANK
01330 359*      ID2=IBLANK
01331 360*      IF(NWRITE.LE.45)GO TO 800
01333 361*      IJ1=ITX(I,1)
01334 362*      ID2=ITX(I,2)
01335 363*      WRITE(6,1005)
01337 364*      WRITE(6,1795)
01341 365*      WRITE(6,1809)
01343 366*      NWRITE=0
01344 367*      800 CONTINUE
01347 368*      IF(NCULL.LE.0)GO TO 821
01351 369*      WRITE(6,1800)
01353 370*      1800 FORMAT(1H1,12X62HCULLED EQUIPMENTS (POWER IN IS LESS THAN RECEIVER
01353 371*      . SENSITIVITY))
01354 372*      WRITE(6,1810)
01356 373*      1809 FORMAT('0TRANSMITTER RECEIVER      S/I + PT + IF + GT
01356 374*      .+ GR - LP = PI > RS . . . . . REMARKS'//)
01357 375*      1810 FORMAT('0TRANSMITTER RECEIVER      S/I + PT + LF + GT
01357 376*      .+ GR - LP = PI < RS . . . . . REMARKS'//)
01360 377*      NWRITE=0
01361 378*      DO 820 M=I,NCULL
01364 379*      ERR=CULL(1,M)
01365 380*      CALL UNPACK(CULL(2,M),I,NHARM)
01366 381*      J=I/50
01367 382*      I=I-J*50
01370 383*      RID1=RX(J,1)
01371 384*      RID2=RX(J,2)
01372 385*      BULK=CULL(5,M)
01373 386*      PI=RX(J,20)+TX(I,9)+CULL(3,M)+TX(I,10)+RX(J,19)-CULL(4,M)
01374 387*      IF(IT1.NE.ITX(I,1))GO TO 805
01376 388*      IF(IT2.NE.ITX(I,2))GO TO 805
01400 389*      GO TO 810
01401 390*      805 NTRAN1=ITX(I,1)
01402 391*      NTRAN2=ITX(I,2)
01403 392*      IT1=NTRAN1
01404 393*      IT2=NTRAN2
01405 394*      WRITE(6,1793)
01407 395*      NWRITE=NWRITE+1
01410 396*      GO TO 815
01411 397*      810 NTRAN1=IBLANK
01412 398*      NTRAN2=IBLANK
01413 399*      815 WRITE(6,1740),TRAN1,NTRAN2,ID1,ID2,RX(J,20),TX(I,9),CULL(3,M),
01413 400*      . TX(I,10),RX(J,19),CULL(4,M),PI,RX(J,18)
01431 401*      CALL MSG(NHARM)
01432 402*      NWRITE=NWRITE+1
01433 403*      IF(NWRITE.LT.45)GO TO 820
01435 404*      WRITE(6,1800)
01437 405*      WRITE(6,1810)
01441 406*      NWRITE=0
01442 407*      IT1=IBLANK
01443 408*      IT2=IBLANK
01444 409*      820 CONTINUE
01446 410*      821 WRITE(6,1820)

```

Figure IV-2. Continued.

SUBROUTINE MSG ENTRY POINT 0007/
STORAGE USED (BLOCK, NAME, LENGTH)

```
0001 *CODE 0001J3
0002 *DATA 0000S1
0003 *BLANK 000000
0004 *CLCOMM 000020
```

EXTERNAL REFERENCES (BLOCK, NAME)

```
0004 NERR23
0005 NDUUS
0006 MIO23
0007 NERR33
```

STORAGE ASSIGNMENT FOR VARIABLES (BLOCK, TYPE, RELATIVE LOCATION, NAME)

```
0000 000000 1782F 0000 00000/ 1784F 0000 000015 1786F 0000 000031 1792F
0001 000024 1794F 0001 000014 782L 0001 000022 784L 0001 000030 786L 0001 000036 180L
0002 000043 790L 0003 000014 BUM 0003 M 000013 COUPK 0003 000000 DUMMY 0003 000042 184P3
0003 I 000017 KERR
```

```
00101 1* SUBROUTINE MSG(NHARM)
00103 2* COMMON/CLCOMM/UMMT(11),COUPK(8UM(13)),KERR
00104 3* 60 TO 1790,782,784,786,790,788),KEMM
00105 4* 782 WRITE(6,1782)
00107 5* 1782 FORMAT(1H*,109X*RAISED ANT NOT ANGLE 0*)
00110 6* 60 TO 790
00111 7* 784 WRITE(6,1784)
00113 8* 1784 FORMAT(1H*,109X*ANTENNAS TOO CLOSE)
00114 9* 60 TO 790
00115 10* 786 WRITE(6,1786)
00117 11* 1786 FORMAT(1H*,109X*CURVE RANGE EXCEEDED)
00120 12* 60 TO 790
00121 13* 788 WRITE(6,1788)
00123 14* 1788 FORMAT(1H*,109X*BAD MULK HEAD HEIGHT)
00124 15* 1790 IF(NHARM.GT.1)WRITE(6,1792)NHARM
00150 16* 1792 FORMAT(1H*,94X*HH = ,11)
00151 17* IF(COUPK.GT.0.)WRITE(6,1794)COUPK
00155 18* 1794 FORMAT(1H*,100X*LK=,F5.0)
00156 19* END
```

Figure IV-2. Continued.

APPENDIX V

SABRELINER FIRST LEVEL ANALYSIS OUTPUT DATA

The output data obtained from automated portion of the first level analysis conducted during this study are shown in this Appendix.

TRANSMITTERS WITH GOOD DATA

TRANSMITTER	LOW FREQ (MHZ)	HI FREQ (MHZ)	R.F.1	R.F.2	RF2	PT	GT	MT	PCI	PW	PRT	LOW FLTY	HI FLTY	Z-DIST (TH)	HFTGHT (FT)	ANGLE (DEG)	P	H
(MHZ).....(MHZ).....(KHZ).....(KHZ).....	..(DB/DEC)..(DB).....	..(DB).....	..(DB).....	..(DB).....	..(DB).....	..(DB).....(MHZ).....(MHZ).....					
01 WEATH RAD	9355.	9415.	190.	640.	20.	40.	73.	-10.P0	2.3	1.00	6560.	15000.	15000.	24.0	.10	180.	0	1
03 TAC2ABOVE	1025.	1150.	110.	260.	40.	40.	66.	2.P0	3.5	2.50	70.	10000.	10000.	44.0	1.00	0.	0	3
04 ATC XPNOR	1090.	1090.	1280.	12800.	20.	40.	57.	2.P0	.4	.05	70.	10000.	10000.	43.0	1.50	180.	0	3
05 TAC2BELOW	1025.	1150.	110.	260.	40.	40.	66.	2.P0	3.5	2.50	70.	10000.	10000.	110.0	3.14	180.	0	3
62 UHF COMM	225.	400.	12.	120.	80.	40.	45.	2.A3	.0	.00	70.	10000.	10000.	135.0	3.24	180.	0	3
64 VHF COMM2	118.	136.	6.	60.	40.	20.	44.	2.A3	.0	.00	70.	500.	500.	135.0	3.24	180.	0	3
07 TAC1ABOVE	1025.	1150.	110.	260.	40.	40.	66.	2.P0	3.5	2.50	70.	10000.	10000.	146.0	3.27	0.	0	3
08 VHF COMM1	116.	136.	6.	60.	40.	20.	44.	2.A3	.0	.00	70.	500.	500.	165.0	3.27	0.	0	3
09 DOPL RAD	8800.	4300.	10000.	100000.	80.	20.	27.	-20.F2	.0	.00	6560.	10000.	10000.	190.0	3.27	180.	0	1
11 ALTIMETER	4300.	4300.	14000.	200000.	600.	20.	26.	-20.F9	.0	.00	70.	10000.	10000.	340.0	3.00	180.	0	2
12 TAC1BELOW	1025.	1150.	110.	260.	40.	40.	66.	2.P0	3.5	2.50	70.	10000.	10000.	377.0	2.52	180.	0	3

TRANSMITTER HARMONICS

TRANSMITTER	LOW FREQ (MHZ)	HI FREQ (MHZ)	R.F.1	R.F.2	RF2	PT	GT	MT	PCI	PW	PRT	LOW FLTY	HI FLTY	Z-DIST (TH)	HFTGHT (FT)	ANGLE (DEG)	P	H
03 TAC2ABOVE	60.	80.																
04 ATC XPNOR	75.	120.																
05 TAC2BELOW	60.	80.																
62 UHF COMM	120.	130.																
64 VHF COMM2	60.	80.																
07 TAC1ABOVE	60.	80.																
08 VHF COMM1	60.	80.																
11 ALTIMETER	70.	80.																
12 TAC1BELOW	60.	80.																

Figure V-1. AVPAK Output Data.

RECEIVERS WITH GOOD DATA

RECEIVER	LOP FREQ (MHZ)	B (KHZ)	IF (MHZ)	SE1 (DB/DEC)	SF2 (DB)	TM LEV (DB)	SP LEV (DB)	LOW SKL (MHZ)	HI SKL (MHZ)	SPL LOP (DB)	7-DIST (IN)	HT (FT)	AUG R (DFG)	SEMS (DB)	GAIN (DB)	S/T
01 WEATH RAD	935	9415	1000	30	100	600	60	6560	10000	A	24	10	100	0	-104	10
02 GL1 SLOPE	329	335	80	51	100	60	70	200	400	B	8	6	180	0	-101	20
03 TAL 2A LF	962	1024	325	63	80	40	60	840	1150	A	44	1	0	0	-90	10
03 TAC 2A HF	1151	1213	325	63	80	40	60	1030	1330	B	44	1	0	0	-90	10
04 ATC XPHUR	1030	6000	60	60	70	70	70	900	1150	A	43	1	100	0	-74	10
05 TAC 2B LF	962	1024	325	63	80	40	60	840	1150	A	43	1	100	0	-90	10
05 TAC 2B HF	1151	1213	325	63	80	40	60	1030	1330	B	44	1	100	0	-90	10
0A UHF COMM	225	400	40	30	180	100	100	200	450	A	135	3	180	0	-97	10
0B VHF COMM2	118	136	40	17	200	40	100	100	156	B	135	3	180	0	-97	10
07 TAC 1A LF	962	1024	325	63	80	40	60	840	1150	B	146	3	0	0	-90	10
07 TAC 1A HF	1151	1213	325	63	80	40	60	1030	1330	B	146	3	0	0	-90	10
0B VHF COMM1	118	136	40	17	200	40	100	100	156	B	168	1	0	0	-97	10
09 DOPPL RAD	800	800	400	5	100	600	0	6560	10000	A	190	1	180	0	-120	10
10 MARK BEAC	75	75	40	5	70	60	60	70	80	B	324	3	180	0	-61	10
11 ALTIMETER	4300	400	0	20	80	20	70	4100	4500	B	370	2	64	0	-73	10
12 TAC 1B LF	962	1024	325	63	80	40	60	840	1150	A	377	2	52	0	-90	10
12 TAC 1B HF	1151	1213	325	63	80	40	60	1030	1330	B	377	2	52	0	-90	10
13 UHF DIR F	225	400	40	30	180	100	100	200	450	B	438	2	03	0	-97	10
14 VHF NAV1	108	118	40	49	200	80	100	90	130	B	482	5	72	0	-101	20
15 VHF NAV2	108	118	40	49	200	80	100	90	130	B	509	9	08	0	-101	20

Figure V-1. Continued.

TRANSMITTER	RECEIVER	EQUIPMENTS CAUSING POSSIBLE INTERFERENCE (POWER IN GREATER THAN RECEIVER SENSITIVITY)		KNIFE EDGE LOCATION (INCHES)		KNIFE EDGE HEIGHT (FEET)		REMARKS	
		S/I	PT	LF	GT	GR	LP		P1
01	WEATH RAD	10.	73.	-80.	-10.	-20.	-	-119.	LK= 27.
03	TAC2ABOVE	10.	06.	0.	2.	-	-	18.	-74.
	04 ATC XPDR	10.	06.	-48.	2.	-	-	-36.	-90.
	05 TAC 2B LF	10.	66.	-48.	2.	-	-	-36.	-90.
	07 TAC 1A LF	10.	66.	-48.	2.	-	-	-41.	-90.
	07 TAC 1A HF	10.	66.	-48.	2.	-	-	41.	-90.
	12 TAC 1B LF	10.	66.	-48.	2.	-	-	66.	-90.
	12 TAC 1B HF	10.	66.	-48.	2.	-	-	66.	-90.
04	ATC XPDR	20.	57.	-129.	2.	-	-	-87.	LK= 6.
	03 TAC 2A LF	10.	57.	-75.	2.	-	-	62.	-90.
	03 TAC 2A HF	10.	57.	-73.	2.	-	-	62.	-90.
	05 TAC 2B LF	10.	57.	-75.	2.	-	-	34.	-90.
	05 TAC 2B HF	10.	57.	-73.	2.	-	-	34.	-90.
	07 TAC 1A LF	10.	57.	-75.	2.	-	-	73.	-90.
	07 TAC 1A HF	10.	57.	-73.	2.	-	-	73.	-90.
	12 TAC 1B LF	10.	57.	-75.	2.	-	-	52.	-90.
	12 TAC 1B HF	10.	57.	-73.	2.	-	-	52.	-90.
05	TAC2BELOW	20.	66.	-143.	2.	-	-	-101.	LK= 6.
	03 TAC 2A LF	10.	66.	-48.	2.	-	-	64.	-90.
	03 TAC 2A HF	10.	66.	-48.	2.	-	-	64.	-90.
	04 ATC XPDR	10.	66.	0.	2.	-	-	34.	-90.
	07 TAC 1A LF	10.	66.	-48.	2.	-	-	43.	-90.
	07 TAC 1A HF	10.	66.	-48.	2.	-	-	43.	-90.
	12 TAC 1B LF	10.	66.	-48.	2.	-	-	50.	-90.
	12 TAC 1B HF	10.	66.	-48.	2.	-	-	50.	-90.
6A	UMF COMM	20.	45.	0.	2.	-	-	30.	LK= 6.
	02 GL1 SLOPE	10.	45.	-152.	2.	-	-	0.	ANTENNAS TOO CLOSE
	06 VHF COMM2	10.	45.	0.	2.	-	-	40.	-97.
	13 UHF DIR F	10.	45.	0.	2.	-	-	40.	-97.
6B	VHF COMM2	10.	44.	-60.	2.	-	-	0.	H = 2
	06 UHF COMM	10.	44.	0.	2.	-	-	40.	-97.
	13 UHF DIR F	10.	44.	-60.	2.	-	-	34.	H = 2
	14 VHF NAV1	20.	44.	-75.	2.	-	-	40.	-97.
	15 VHF NAV2	20.	44.	-75.	2.	-	-	40.	-97.
07	TAC1ABOVE	10.	00.	-46.	2.	-	-	41.	-90.
	03 TAC 2A LF	10.	00.	-46.	2.	-	-	41.	-90.
	04 ATC XPDR	10.	00.	0.	2.	-	-	73.	-90.

Figure V-1. Continued

EQUIPMENTS CAUSING POSSIBLE INTERFERENCE (POWER IN GREATER THAN RECEIVER SENSITIVITY)																	
TRANSMITTER	RECEIVER	S/I	+	PT	+	LF	+	GT	+	GR	-	LP	=	PI	>	REMARKS	
07	TAC1ABOVE	U5 TAC 2B LF	10.	+	66.	+	-4A.	+	2.	+	2.	-	43.	=	-51.		-90.
		U5 TAC 2B HF	10.	+	66.	+	-4A.	+	2.	+	2.	-	83.	=	-51.		-90.
		12 TAC 1B LF	10.	+	66.	+	-4A.	+	2.	+	2.	-	77.	=	-44.		-90.
		12 TAC 1B HF	10.	+	66.	+	-4A.	+	2.	+	2.	-	77.	=	-44.		-90.
08	VHF COMMI	0A UHF COMM	10.	+	44.	+	-60.	+	2.	+	2.	-	53.	=	-55.		-97. H = 2
		0B VHF COMM2	10.	+	44.	+	0.	+	2.	+	2.	-	41.	=	17.		-97. H = 2
		13 UHF DIR F	10.	+	44.	+	-60.	+	2.	+	2.	-	50.	=	-52.		-97. H = 2
		14 VHF NAV1	20.	+	44.	+	-75.	+	2.	+	2.	-	33.	=	-40.		-101.
		15 VHF NAV2	20.	+	44.	+	-75.	+	2.	+	2.	-	33.	=	-41.		-101.
12	TAC1BELOW	U3 TAC 2A LF	10.	+	66.	+	-4A.	+	2.	+	2.	-	66.	=	-34.		-90.
		U3 TAC 2A HF	10.	+	66.	+	-4A.	+	2.	+	2.	-	66.	=	-34.		-90.
		U4 ATC XPDR	10.	+	66.	+	0.	+	2.	+	2.	-	52.	=	2A.		-74.
		U5 TAC 2B LF	10.	+	66.	+	-4A.	+	2.	+	2.	-	50.	=	-1A.		-90.
		U5 TAC 2B HF	10.	+	66.	+	-4A.	+	2.	+	2.	-	50.	=	-1A.		-90.
		U7 TAC 1A LF	10.	+	66.	+	-4A.	+	2.	+	2.	-	77.	=	-44.		-90.
		U7 TAC 1A HF	10.	+	66.	+	-4A.	+	2.	+	2.	-	77.	=	-44.		-90.

Figure V-1. Continued.

EQUIPMENTS CAUSING POSSIBLE INTERFERENCE (POWER IN GREATER THAN RECEIVER SENSITIVITY)																
TRANSMITTER	RECEIVER	S/I	+	PT	+	LF	+	GT	+	GR	-	LP	=	PI	>	REMARKS
07 TAC1ABOVE	05 TAC 2B LF	10.	+	06.	+	-48.	+	2.	+	2.	-	83.	=	-51.		-90.
	05 TAC 2B HF	10.	+	06.	+	-48.	+	2.	+	2.	-	83.	=	-51.		-90.
	12 TAC 1B LF	10.	+	06.	+	-48.	+	2.	+	2.	-	77.	=	-44.		-90.
08 VHF COMM1	12 TAC 1B HF	10.	+	06.	+	-48.	+	2.	+	2.	-	77.	=	-44.		-90.
	0A UHF COMM	10.	+	44.	+	-60.	+	2.	+	2.	-	53.	=	-55.		-97. H = 2
	0E VHF COMM2	10.	+	44.	+	0.	+	2.	+	2.	-	41.	=	17.		-97.
	13 UHF DIR F	10.	+	44.	+	-60.	+	2.	+	2.	-	50.	=	-52.		-97. H = 2
	14 VHF NAV1	20.	+	44.	+	-75.	+	2.	+	2.	-	33.	=	-40.		-101.
15 VHF NAV2	20.	+	44.	+	-75.	+	2.	+	2.	-	33.	=	-41.		-101.	
12 TAC1BELOW	03 TAC 2A LF	10.	+	06.	+	-48.	+	2.	+	2.	-	06.	=	-34.		-90.
	03 TAC 2A HF	10.	+	06.	+	-48.	+	2.	+	2.	-	06.	=	-34.		-90.
	04 ATC XPDR	10.	+	06.	+	0.	+	2.	+	2.	-	52.	=	28.		-74.
	05 TAC 2B LF	10.	+	06.	+	-48.	+	2.	+	2.	-	50.	=	-18.		-90.
	05 TAC 2B HF	10.	+	06.	+	-48.	+	2.	+	2.	-	50.	=	-18.		-90.
	07 TAC 1A LF	10.	+	06.	+	-48.	+	2.	+	2.	-	77.	=	-44.		-90.
	07 TAC 1A HF	10.	+	06.	+	-48.	+	2.	+	2.	-	77.	=	-44.		-90.

Figure V-1. Continued.

COLLECTED EQUIPMENTS (POWER IN) IS LESS THAN RECEIVER SENSITIVITY)

TRANSMITTER	RECEIVER	S/I	PT	LF	GT	GP	LP	PI	<	MS	RFMARKS
01 WEATH RAD	02 GLI SLOPE	20	73	+ -212	+ -10	+ 2	- 44	= -171		-101	LK= 27
03 TAC 2A LF	03 TAC 2A HF	10	73	+ -133	+ -10	+ 2	- 74	= -132		-90	LK= 27
04 ATC XPDR	04 ATC XPDR	10	73	+ -134	+ -10	+ 2	- 69	= -193		-90	LK= 21
05 TAC 2B LF	05 TAC 2B HF	10	73	+ -133	+ -10	+ 2	- 85	= -143		-90	LK= 25
06 UHF COMM	06 UHF COMM	10	73	+ -312	+ -10	+ 2	- 88	= -325		-97	LK= 26
07 VHF COMM2	07 VHF COMM2	10	73	+ -320	+ -10	+ 2	- 88	= -332		-97	LK= 26
07 TAC 1A LF	07 TAC 1A HF	10	73	+ -134	+ -10	+ 2	- 90	= -144		-90	LK= 28
08 VHF COMM1	08 VHF COMM1	10	73	+ -320	+ -10	+ 2	- 92	= -336		-97	LK= 28
10 MARK BEAC	10 MARK BEAC	10	73	+ -253	+ -10	+ -5	- 98	= -282		-61	LK= 28
11 ALTIMETER	11 ALTIMETER	10	73	+ -182	+ -10	+ -20	- 99	= -228		-73	LK= 28
12 TAC 1B LF	12 TAC 1B HF	10	73	+ -133	+ -10	+ 2	- 99	= -157		-90	LK= 29
13 UHF DIR F	13 UHF DIR F	10	73	+ -134	+ -10	+ 2	- 101	= -338		-97	LK= 28
14 VHF NAV1	14 VHF NAV1	20	73	+ -312	+ -10	+ 2	- 102	= -355		-101	LK= 29
15 VHF NAV2	15 VHF NAV2	20	73	+ -337	+ -10	+ 2	- 103	= -355		-101	LK= 29
03 TAC2ABOVE	01 WEATH RAD	10	66	+ -252	+ 2	+ -10	- 55	= -240		-104	H = 2 LK= 20
02 GLI SLOPE	02 GLI SLOPE	20	66	+ -143	+ 2	+ 2	- 50	= -103		-101	LK= 17
04 UHF COMM	04 UHF COMM	10	66	+ -175	+ 2	+ 2	- 68	= -163		-97	
05 VHF COMM2	05 VHF COMM2	10	66	+ -181	+ 2	+ 2	- 68	= -170		-97	
08 VHF COMM1	08 VHF COMM1	10	66	+ -181	+ -2	+ 2	- 43	= -144		-97	
09 DUPL RAD	09 DUPL RAD	10	66	+ -253	+ 2	+ -20	- 81	= -276		-120	H = 2
10 MARK BEAC	10 MARK BEAC	10	66	+ -182	+ 2	+ -5	- 67	= -177		-61	
11 ALTIMETER	11 ALTIMETER	10	66	+ -173	+ 2	+ -20	- 85	= -200		-73	H = 3
13 UHF DIR F	13 UHF DIR F	10	66	+ -175	+ 2	+ 2	- 65	= -160		-97	
14 VHF NAV1	14 VHF NAV1	20	66	+ -182	+ 2	+ 2	- 54	= -146		-101	
15 VHF NAV2	15 VHF NAV2	20	66	+ -182	+ 2	+ 2	- 55	= -146		-101	
04 ATC XPDR	01 WEATH RAD	10	57	+ -221	+ 2	+ -10	- 50	= -213		-104	H = 2 LK= 15
04 UHF COMM	04 UHF COMM	10	57	+ -134	+ 2	+ 2	- 41	= -103		-97	
05 VHF COMM2	05 VHF COMM2	10	57	+ -139	+ 2	+ 2	- 41	= -100		-97	
05 VHF COMM1	05 VHF COMM1	10	57	+ -139	+ 2	+ 2	- 72	= -141		-97	
09 DUPL RAD	09 DUPL RAD	10	57	+ -222	+ 2	+ -20	- 51	= -224		-120	H = 2
10 MARK BEAC	10 MARK BEAC	10	57	+ -141	+ 2	+ -5	- 50	= -127		-61	
11 ALTIMETER	11 ALTIMETER	10	57	+ -214	+ 2	+ -20	- 51	= -226		-73	H = 3
13 UHF DIR F	13 UHF DIR F	10	57	+ -134	+ 2	+ 2	- 53	= -114		-97	
14 VHF NAV1	14 VHF NAV1	20	57	+ -140	+ -2	+ 2	- 61	= -120		-101	
15 VHF NAV2	15 VHF NAV2	20	57	+ -140	+ 2	+ 2	- 62	= -121		-101	
05 TAC2BELOW	01 WEATH RAD	10	66	+ -252	+ 2	+ -10	- 66	= -250		-104	H = 2 LK= 19
04 UHF COMM	04 UHF COMM	10	66	+ -175	+ 2	+ 2	- 29	= -124		-87	

Figure V-1. Continued.

CULLED EQUIPMENTS (POWER IS LESS THAN RECEIVER SENSITIVITY)

TRANSMITTER	RECEIVER	S/I	PT	LF	GT	GC	LP	PI	REMARKS
05 TAC2BELOW	03 VHF COM2	10	66	-181	2	2	29	-131	-97.
	04 VHF COM1	10	66	-181	2	2	43	-184	-97.
	09 DGPL RAD	10	66	-253	2	-20	45	-240	-120. H = 2
	10 MARK BEAC	10	66	-162	2	-5	48	-157	-61.
	11 ALTIMETER	10	66	-173	2	-20	59	-174	-73. H = 3
	13 VHF DIR F	10	66	-175	2	2	52	-147	-97.
	14 VHF NAV1	20	66	-182	2	2	69	-160	-101.
	15 VHF NAV2	20	66	-182	2	2	68	-160	-101.
6A VHF COM1	01 ELATH RAD	10	45	-387	2	-10	52	-392	-104. H = 2 LK = 14.
	03 TAC 2A LF	10	45	-185	2	2	57	-183	-90. H = 2
	05 TAC 2A HF	10	45	-190	2	2	57	-197	-90. H = 2
	04 ATC XPIJOK	10	45	-207	2	2	36	-184	-74. H = 2
	05 TAC 2B LF	10	45	-185	2	2	24	-150	-90. H = 2
	05 TAC 2B HF	10	45	-190	2	2	24	-164	-90. H = 2
	07 TAC 1A LF	10	45	-185	2	2	71	-197	-90. H = 2
	07 TAC 1A HF	10	45	-190	2	2	71	-210	-90. H = 2
	06 VHF COM1	10	45	-152	2	2	56	-140	-97.
	09 DGPL RAD	10	45	-387	2	-20	31	-381	-120. H = 2
	10 MARK BEAC	10	45	-130	2	-5	36	-123	-61.
	11 ALTIMETER	10	45	-280	2	-20	44	-296	-73. H = 2
	12 TAC 1B LF	10	45	-185	2	2	44	-170	-90. H = 2
	12 TAC 1B HF	10	45	-199	2	2	44	-184	-90. H = 2
	14 VHF NAV1	20	45	-176	2	2	51	-158	-101.
	15 VHF NAV2	20	45	-176	2	2	51	-158	-101.
6B VHF COM2	01 ELATH RAD	10	44	-227	2	-10	41	-222	-104. H = 2 LK = 11.
	02 GL1 SLOPE	20	44	-160	2	2	40	-132	-101. H = 3 LK = 6.
	03 TAC 2A LF	10	44	-150	2	2	43	-135	-90. H = 2
	03 TAC 2A HF	10	44	-154	2	2	43	-140	-90. H = 2
	04 ATC XPIJOK	10	44	-164	2	2	28	-154	-74. H = 2
	05 TAC 2B LF	10	44	-150	2	2	17	-109	-90. H = 2
	05 TAC 2B HF	10	44	-154	2	2	17	-113	-90. H = 2
	07 TAC 1A LF	10	44	-150	2	2	53	-145	-90. H = 2
	07 TAC 1A HF	10	44	-154	2	2	53	-149	-90. H = 2
	09 DGPL RAD	10	44	-227	2	-20	23	-215	-120. H = 2
	10 MARK BEAC	10	44	-100	2	-5	20	-83	-61.
	11 ALTIMETER	10	44	-224	2	-20	30	-224	-73. H = 2
	12 TAC 1B LF	10	44	-150	2	2	36	-128	-90. H = 2
	12 TAC 1B HF	10	44	-154	2	2	36	-133	-90. H = 2
07 TAC1A0+E	01 ELATH RAD	10	60	-252	2	-10	71	-255	-104. H = 2 LK = 22.
	02 GL1 SLOPE	20	66	-143	2	2	60	-113	-101.
	04 VHF COM1	10	66	-175	2	2	84	-179	-97.

Figure V-1. Continued.

COLLECTED EQUIPMENTS (POWER IN 15 LESS THAN RECEIVER SENSITIVITY)											
TRANSMITTER	RECEIVER	S/I	PT	LF	GT	GP	LP	PI	REMARKS	REMARKS	REMARKS
07	TACIABOVE	10.	66.	+181.	2.	2.	84.	= -185.	-97.		
	08 VHF COMM2	10.	66.	+181.	2.	2.	28.	= -129.	-97.		
	08 VHF COMM1	10.	66.	+181.	2.	2.	103.	= -297.	-120.	H = 2	
	09 DOPL RAD	10.	66.	+253.	2.	-5.	80.	= -189.	-61.		
	10 MARK BEAC	10.	66.	+182.	2.	2.	103.	= -217.	-73.	H = 3	
	11 ALTIMETER	10.	66.	+175.	2.	2.	74.	= -169.	-97.		
	13 UHF DIR F	10.	66.	+173.	2.	2.	52.	= -144.	-90.	H = 2	
	14 VHF NAVI	20.	66.	+182.	2.	2.	15.	= -108.	-90.	H = 2	
	15 VHF NAV2	20.	66.	+182.	2.	2.	53.	= -144.	-101.		
08	VHF COMM1	10.	44.	+227.	2.	-10.	45.	= -226.	-104.	H = 2 LK= 13.	
	01 WEATH RAD	20.	44.	+227.	2.	2.	48.	= -240.	-101.	H = 3 LK= 12.	
	02 GLI SLOPE	20.	44.	+160.	2.	2.	31.	= -123.	-90.	H = 2	
	03 TAC 2A LF	10.	44.	+150.	2.	2.	31.	= -127.	-90.	H = 2	
	03 TAC 2A HF	10.	44.	+154.	2.	2.	46.	= -172.	-74.	H = 2	
	04 ATC XPRDR	10.	44.	+184.	2.	2.	52.	= -144.	-90.	H = 2	
	05 TAC 2B LF	10.	44.	+150.	2.	2.	15.	= -108.	-90.	H = 2	
	05 TAC 2B HF	10.	44.	+154.	2.	2.	15.	= -112.	-90.	H = 2	
	07 TAC 1A LF	10.	44.	+150.	2.	2.	53.	= -244.	-120.	H = 2	
	07 TAC 1A HF	10.	44.	+154.	2.	2.	42.	= -97.	-61.		
	09 DOPL RAD	10.	44.	+228.	2.	-5.	51.	= -239.	-73.	H = 2	
	10 MARK BEAC	10.	44.	+106.	2.	2.	51.	= -143.	-90.	H = 2	
	11 ALTIMETER	10.	44.	+224.	2.	2.	51.	= -147.	-90.	H = 2	
	12 TAC 1B LF	10.	44.	+150.	2.	2.					
	12 TAC 1B HF	10.	44.	+154.	2.	2.					
09	DOPL RAD	10.	27.	+69.	-20.	-10.	91.	= -153.	-104.	LK= 27.	
	01 WEATH RAD	20.	27.	+228.	-20.	2.	74.	= -277.	-101.	LK= 13.	
	02 GLI SLOPE	20.	27.	+146.	-20.	2.	117.	= -244.	-90.		
	03 TAC 2A LF	10.	27.	+147.	-20.	2.	117.	= -245.	-90.		
	03 TAC 2A HF	10.	27.	+147.	-20.	2.	63.	= -243.	-74.		
	04 ATC XPRDR	10.	27.	+199.	-20.	2.	54.	= -184.	-90.		
	05 TAC 2B LF	10.	27.	+146.	-20.	2.	54.	= -184.	-90.		
	05 TAC 2B HF	10.	27.	+147.	-20.	2.	54.	= -362.	-97.		
	0A UHF COMM	10.	27.	+327.	-20.	2.	54.	= -370.	-97.		
	0B VHF COMM2	10.	27.	+335.	-20.	2.	148.	= -274.	-90.		
	07 TAC 1A LF	10.	27.	+146.	-20.	2.	148.	= -277.	-90.		
	07 TAC 1A HF	10.	27.	+147.	-20.	2.	149.	= -465.	-97.		
	08 VHF COMM1	10.	27.	+335.	-20.	2.	65.	= -314.	-61.		
	10 MARK BEAC	10.	27.	+268.	-20.	-5.	65.	= -260.	-73.		
	11 ALTIMETER	10.	27.	+192.	-20.	2.	65.	= -192.	-90.		
	12 TAC 1B LF	10.	27.	+146.	-20.	2.	67.	= -374.	-97.		
	12 TAC 1B HF	10.	27.	+147.	-20.	2.	113.	= -437.	-101.		
	13 UHF DIR F	10.	27.	+327.	-20.	2.	110.	= -434.	-101.		
	14 VHF NAVI	20.	27.	+353.	-20.	2.					
	15 VHF NAV2	20.	27.	+353.	-20.	2.					
11	ALTIMETER	10.	26.	+151.	-20.	-10.	97.	= -242.	-104.	H = 2 LK= 28.	

Figure V-1. Continued.

COLLEGE EQUIPMENTS (POWER IN IS LESS THAN RECEIVER SENSITIVITY)

TRANSMITTER	RECEIVER	S/I	PT	LF	GT	GR	LP	PI	<	PS	RFMARKS
11	ALTIMETER										
	U2 GL1 SLOPE	20.	26.	-157.	-20.	?	7A.	-207.			LK= 14.
	U3 TAC 2A LF	10.	26.	-143.	-20.	?	92.	-217.			
	U3 TAC 2A HF	10.	26.	-143.	-20.	?	92.	-217.			
	U4 ATC XP:HR	10.	26.	-137.	-20.	?	63.	-182.			
	U5 TAC 2B LF	10.	26.	-143.	-20.	?	60.	-185.			
	U5 TAC 2B HF	10.	26.	-143.	-20.	?	60.	-186.			
	0A UHF COMM	10.	26.	-160.	-20.	?	59.	-202.			
	0B VHF COMM2	10.	26.	-161.	-20.	?	59.	-202.			
	U7 TAC 1A LF	10.	26.	-143.	-20.	?	114.	-239.			
	U7 TAC 1A HF	10.	26.	-143.	-20.	?	114.	-239.			
	U8 VHF COMM1	10.	26.	-161.	-20.	?	115.	-25A.			
	U9 DOPL RAD	10.	26.	-172.	-20.	-20.	63.	-239.			-120. H = ?
	10 MARK BEAC	10.	26.	-161.	-20.	-5.	37.	-187.			-61.
	12 TAC 1B LF	10.	26.	-143.	-20.	?	45.	-170.			-90.
	12 TAC 1B HF	10.	26.	-143.	-20.	?	45.	-170.			-90.
	15 UHF DIR F	10.	26.	-160.	-20.	?	53.	-195.			-97.
	14 VHF NAV1	20.	26.	-161.	-20.	?	96.	-220.			-101.
	15 VHF NAV2	20.	26.	-161.	-20.	?	93.	-226.			-101.
12	TAC1BELOW										
	U1 BLATH RAD	10.	66.	-252.	?	-10.	80.	-264.			-104. H = 2 LK= ??
	U2 GL1 SLOPE	20.	66.	-143.	?	?	62.	-115.			-101.
	0A UHF COMM	10.	66.	-175.	?	?	49.	-144.			-97.
	0B VHF COMM2	10.	66.	-181.	?	?	49.	-150.			-97.
	0B VHF COMM1	10.	66.	-181.	?	?	77.	-17A.			-97.
	U9 DOPL RAD	10.	66.	-253.	?	-20.	53.	-24A.			-120. H = 2
	10 MARK BEAC	10.	66.	-182.	?	-5.	36.	-145.			-61.
	11 ALTIMETER	10.	66.	-173.	?	-20.	2A.	-142.			-73. H = 3
	13 UHF DIR F	10.	66.	-175.	?	?	37.	-132.			-97.
	14 VHF NAV1	20.	66.	-182.	?	?	64.	-155.			-101.
	15 VHF NAV2	20.	66.	-182.	?	?	64.	-156.			-101.

Figure V-1. Continued.

TABLE OF INTERFERING EQUIPMENTS (X=INTERFERING)

TRANSMITTER	0	1	2	3	4	5	6	7	8	9	0	1	1	1	1	1	1	1	RECEIVER CODES
01 WEATH RAD																			01 WEATH RAD
03 TAC2ABOVE	X	X	X																02 GLI SLOPF
04 ATC XPDR	X	X	X	X	X														03 TAC 2A LF
05 TAC2BELOW	X	X	X	X	X														04 TAC 2A HF
6A UHF COMM	A						X												05 ATC XPDR
6B VHF COMM2							X												06 TAC 2R LF
07 TAC1ABOVE	X	X	X	X	X														07 TAC 2R HF
08 VHF COMM1							X												6A UHF COMM
09 DOPL RAD								X											6B VHF COMM2
11 ALTIMETER																			07 TAC 1A LF
12 TAC1BELOW	X	X	X	X	X														07 TAC 1A HF
																			08 VHF COMM1
																			09 DOPL RAD
																			10 MARK REAC
																			11 ALTIMETER
																			12 TAC 1R LF
																			12 TAC 1R HF
																			13 UHF DIP F
																			14 VHF NAV1
																			15 VHF NAV2

Figure V-1. Continued.

REFERENCES

1. Inter-Agency Agreement, DOT-FA70WAI-175, Task Assignment No. 2.
2. Jasik, H., ed., *Antenna Engineering Handbook*, Mc Graw-Hill, New York, 1961.
3. Kraus, J.D., *Antennas*, McGraw-Hill, New York, 1950.
4. Hasserjian, G., and Ishimaru, A., "Excitation of a Conducting Cylindrical Surface of Large Radius of Curvature", *IRE Transactions on Antennas and Propagation*, VOL AP-10, May, 1962.
5. Khan, P.J., et al., "Derivation of Aerospace Antenna Coupling Factor," *Interference Prediction Techniques*, Cooley Electronics Laboratory, University of Michigan, 1964.
6. Herd, A., *An Automated Antenna Coupling Loss Calculation Technique for a Cylindrical Body*, ESD-TR-70-209, ECAC, 1970.
7. Cleaver, R., and Bode, T., *An Algorithm for Calculating Transmitter - Receiver Frequency Rejection Loss*, ESD-TR-70-128, ECAC, 1970.
8. Mason, S., and Zimmerman, H., *Electronic Circuits, Signals and Systems*, John Wiley and Sons, New York, 1960.
9. Klauder, J.R., et al., "The Theory and Design of Chirp Radars," *The Bell System Technical Journal*, July, 1960.
10. O'Brian, P., and Busch, A., *Effects of Selective Signal Parameters on Communications Intelligibility*, FAA Report NA-69-21, Federal Aviation Agency, Atlantic City, 1969.
11. *FAA Frequency Management Engineering Principles, Geographic Separation Criteria for VOR, DME, TACAN, ILS and VOT Frequency Assignments*, Federal Aviation Agency, Washington, D. C., 1965.
12. Himmelheber, P., *Investigation of TACAN/IFF Compatibility*, Problem No. 67-18, Naval Electronics Systems Command, Patuxent River, Md. 1967.
13. Shaw, K., et al., *TACAN/DME Interference to the Air Traffic Control Radar Beacon System*, ESD-TR-70-292, ECAC, 1970.

UNCLASSIFIED

Security Classification

DOCUMENT CONTROL DATA - R & D

(Security classification of title, body of abstract and indexing annotation must be entered when the overall report is classified)

ORIGINATING ACTIVITY (Corporate author) Electromagnetic Compatibility Analysis Center	2a. REPORT SECURITY CLASSIFICATION UNCLASSIFIED
	2b. GROUP

REPORT TITLE
AVIONICS INTERFERENCE PREDICTION MODEL

DESCRIPTIVE NOTES (Type of report and inclusive dates)
Technical Report

AUTHOR(S) (First name, middle initial, last name)

Morgan, G.

REPORT DATE November 1970	7a. TOTAL NO. OF PAGES	7b. NO. OF REFS
------------------------------	------------------------	-----------------

CONTRACT OR GRANT NO. F-19628-70-C-0291	9a. ORIGINATOR'S REPORT NUMBER(S) ESD-TR-70-286
PROJECT NO. 649E	

DISTRIBUTION STATEMENT

Distribution of this document is unlimited.

SUPPLEMENTARY NOTES	12. SPONSORING MILITARY ACTIVITY Department of Defense
---------------------	---

ABSTRACT

An interference prediction model developed for use in evaluating expected interactions between avionics equipments on an airplane is described. The model is substantially automated and includes subroutines which calculate expected path losses between aircraft antennas and the rejection offered by the receivers to the undesired emissions from transmitters on the aircraft.

An analysis of the interactions between the equipments installed on an FAA Sabreliner has been made using the prediction model and the results of the analysis are described.

Requirements for expansion of the prediction model are established.

14.	KEY WORDS	LINK A		LINK B		LINK C	
		ROLE	WT	ROLE	WT	ROLE	WT