

3 July 1969

Materiel Test Procedure 10-2-068  
General Equipment Test Activity

U. S. ARMY TEST AND EVALUATION COMMAND  
COMMODITY ENGINEERING TEST PROCEDURE

DEHUMIDIFIERS

1. OBJECTIVE

This document provides test methods and techniques necessary to determine the technical performance and safety characteristics of dehumidifiers and their associated tools and equipment as described in Qualitative Materiel Requirements (QMR's), Small Development Requirements (SDR's), Technical Characteristics (TC's) and to determine the item's suitability for service tests.

2. BACKGROUND

A requirement exists for a device which can provide for the reduction of water vapor in the air thereby lowering the relative humidity. This device is entitled, "dehumidifier". The extraction of the air's moisture is desirable, either because it results in greater comfort in the environment or because it minimizes the undesirable effects which water can produce in inanimate objects through adsorption or water stimulated chemical processes. Moisture is generally removed from the air by one of two processes: (1) by cooling the air below its dewpoint so that condensation occurs, or (2) by passing the air through a sorbent material which will extract and hold water vapor. These two processes will be referred to as the refrigeration and sorption methods. Dehumidifiers will, in general use one of these methods to perform their intended function.

The refrigeration technique involves passing the air through cooling coils whose surface temperature is below the dew point of the air. Here both moisture and heat are removed from the air and with this method the air is usually reheated before expelling it to the workspace.

Sorbents are substances which have the property of extracting and holding other substances (usually gases or vapors, e.g. water vapor) brought into contact with them. As generally used, however, the term sorbent refers to those materials having a capacity for moisture which is large compared to their volume and weight. Such materials are divided into two general classifications: (1) Adsorbent - A sorbent which does not change physically or chemically during the sorption process. (Certain valid materials such as activated alumina and silica gel have this property) (2) Absorbent - A sorbent which changes either physically or chemically or both during the sorption process (Calcium Chloride is an example of a solid absorbent while liquid absorbents include solutions of lithium chloride and the ethylene glycols).

Dehumidifiers can utilize either one or both of the described methods to perform their intended function. The two methods are illustrated in Figure 1. as traverse paths on simplified psychrometric charts.

3. REQUIRED EQUIPMENT

REPRODUCTION OF THIS DOCUMENT IS PROHIBITED  
SPECIAL INSTRUCTIONS FOR REPRODUCTION  
REPRODUCTION PROHIBITED

Reproduced by  
NATIONAL TECHNICAL  
INFORMATION SERVICE  
Springfield, Va. 22151

D D C  
RECEIVED  
MAR 5 1971  
RECEIVED

35

AD719146

MTP 10-2-068  
3 July 1969

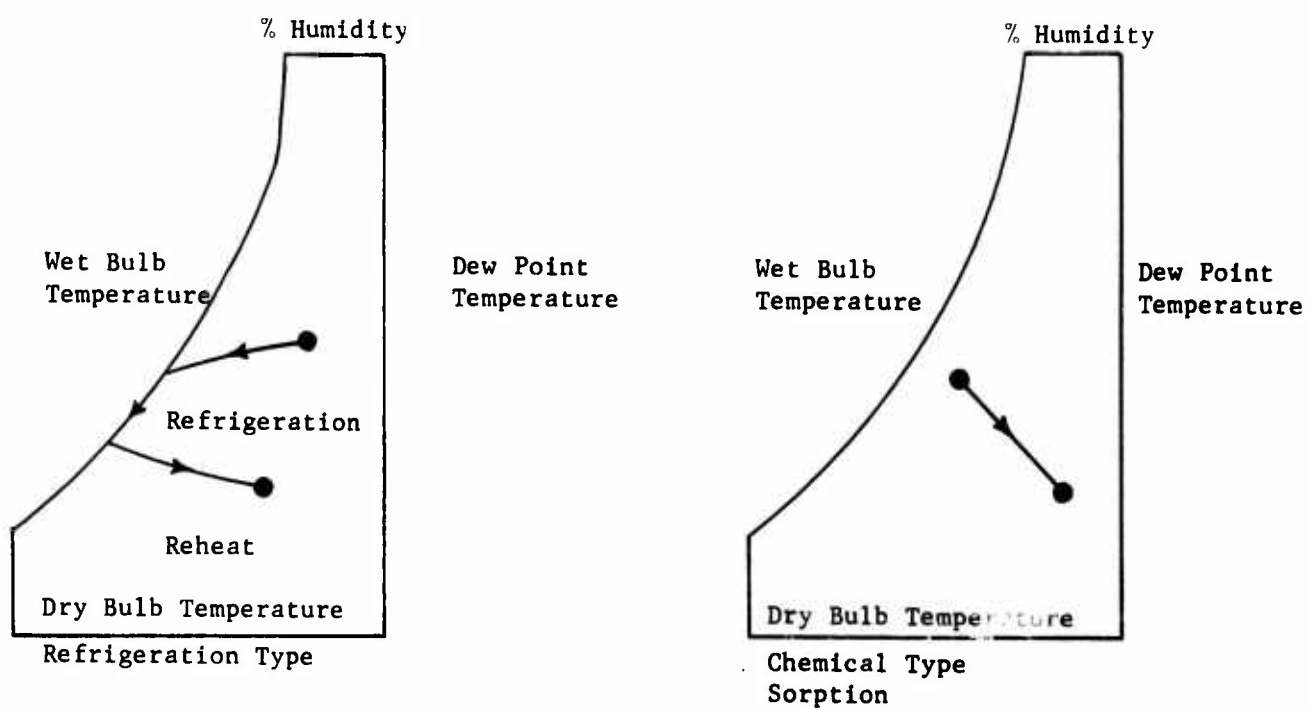

FIGURE 1. METHODS OF DEHUMIDIFICATION

**BLANK PAGE**

3 July 1969

- a. ASHRAE Psychrometric Chart.
- b. Table of Thermodynamic Properties of Moist Air.
- c. Mercury-In-Glass Thermometers in °F accurate to 0.1°F, as required for wet and dry bulb.
- d. Thermocouples and associated recording equipment as required.
- e. Voltmeter, ac and dc, as required, accurate to 0.5 percent.
- f. Kilowatt-hour Meters, ac and dc, as required, accurate to 0.5 percent.
- g. Ammeters, ac and dc, as required, accurate to 0.5 percent.
- h. Ohmmeter
- i. Dielectric Strength Tester (0-3000 VRMS, 25-60 Hz).
- j. Wheatstone Bridge.
- k. Millivolt Potentiometer or Calibrated Temperature Bridge with Thermocouples.
- l. 500-Volt DC Current Megohmmeter or Bridge
- m. Sound Level Meter meeting the requirements of USA Std S1.4-1964.
- n. Octave Band Filter Set meeting the requirements of USA Std Z24-10-1953.
- o. Sound Measurement Anechoic Room or Semireverberant Chamber, as required.
- p. Pitot Tubes, as required.
- q. Duct Traverse Plan (AIR Standard)
- r. Ducts, Tubing and Piping, as required.
- s. Manometer, Liquid-In-Glass, Inclined, as required.
- t. Barometer
- u. Air-Conditioner for conditioning of inlet air.
- v. Environmental Test Chambers, as required.
- w. Scales, accurate to 0.2 percent, for measuring condensate.
- x. For Sorption Dehumidifiers, when required:
  - 1) Steam Service
  - 2) Gas or liquid fuel
  - 3) Gas Flow Meters
  - 4) Gas Pressure Gauges
  - 5) Table of Heating Fuels for gaseous and liquid fuels.
  - 6) Characteristic Curves of Temperature, Vapor Pressure, and Concentration for applicable sorbent material.
  - 7) Revolving-Drum Condensate Meter.
- y. Sling Psychrometer or an Air Sampling Tube with appropriate ventilating means.
- z. Vibration Amplitude Measuring set.
- aa. Equipment and Facilities, as required by the references MTP's and test methods.

#### 4. REFERENCES

- A. Strock, Handbook of Air Conditioning, Heating and Ventilation, Industrial Press, 1959.
- B. Trane, Air Conditioning Manual, Trane Co. 1955.
- C. Haines, Automatic Control of Heating and Air Conditioning, McGraw Hill, 1961

MTP 10-2-068

3 July 1969

- D. Severns and Fellows, Air Conditioning and Refrigeration, J. Wiley and Sons.
- E. ASHRAE, Guide and Data Books, American Society of Heating, Refrigeration and Air Conditioning Engineers, 1967.
- F. ASHRAE, Handbook of Fundamentals, American Society of Heating, Refrigeration and Air Conditioning Engineers, 1967.
- G. Doolittle, Thermodynamics for Engineers, International Textbook Co., 1959.
- H. MIL-STD-129, Marking for Shipment and Storage.
- I. MIL-STD-130, Identification Marking of U. S. Military Property.
- J. MIL-STD-461, Electromagnetic Interference Characteristics, Requirements for Equipment.
- K. MIL-STD-462, Electromagnetic Interference Characteristics, Measurement of
- L. MIL-STD-463, Definition and System of Units, Electromagnetic Interference Technology.
- M. MIL-STD-810B, Environmental Test Methods.
- N. MIL-H-22577, Heating Elements, Electrical; Cartridge, Strip and Tubular Type.
- O. USA-STD. B9.1 - 1964, Safety Code for Mechanical Refrigeration, Sponsor, American Society of Heating Refrigeration and Air Conditioning Engineers.
- P. USA Std. S1.2-1962, Physical Measurement of Sound.
- Q. USA Std. S1.4 - 1961, General Purpose Sound Level Meters.
- R. HEL Standard S-1-63B, Maximum Noise Level for Army Materiel Command Equipment, June 1965.
- S. AHAM DH-1 - 1968, Dehumidifiers (Self contained, electrically operated, mechanically refrigerated), Association of Home Appliances Manufacturers.
- T. NEMA MG 1 - 1966, Motors and Generators, Part 12, Tests and Performance, AC and DC Fractional and Integral Horsepower Motors, National Electrical Manufacturers Association.
- U. UL 474 - 1968, Standards for Safety - Dehumidifiers, Underwriters Laboratories, Inc.
- V. USATECOM Regulation 385-6, Safety Release.
- W. USATECOM Regulation 700-1, Value Engineering.
- X. USATECOM Regulation 705-4, Equipment Performance Report.
- Y. MTP 10-2-500, Physical Characteristics.
- Z. MTP 10-2-501, Operator Training and Familiarization.
- AA. MTP 10-2-503, Surface Transportability (General Supplies and Equipment).
- AB. MTP 10-2-505, Human Factors Evaluation.
- AC. MTP 10-2-507, Maintenance Evaluation.

5. SCOPE

5.1 SUMMARY

This procedure describes the preparation for and methods of evaluating the technical characteristics of dehumidifiers. The tests used are designed to measure and provide maximum information on all parameters of the test item,

from an operating system standpoint. Tests on components or subsystems of the test item will be included only insofar as their individual performance cannot be ascertained from the overall performance of the complete test item. In particular the performance factor of the dehumidifier; a ratio of the amount of moisture removed to the amount of power supplied over a specified duration of time, will be determined.

a. Preparation for test - A determination of the condition of the test item upon arrival, its physical characteristics, its suitability for subjection to further tests and operator training and familiarization.

b. Preliminary Electrical Measurements - An evaluation to determine the test item's condition prior to the application of normal operating power and to obtain data for later comparison tests.

c. Operation and Performance - An evaluation to determine the degree to which the test item performs its primary function. In particular, the test item's rated capacity and rated input will be determined yielding the performance factor which is a ratio of the rated parameters. Test item controls and indicators will also be checked.

d. Electromagnetic Interference - An evaluation to determine the degree to which the test item produced radiated or line conducted interferences.

e. Durability - An evaluation of the test item's ability to retain original performance characteristics after extended operation.

f. Environmental Tests - An evaluation to determine the ability of the test item to resist physical damage and to function properly during or after exposure to the extremes of environment.

g. Balance Test - An evaluation to determine the test item's ability to counterbalance forces introduced by moving components.

h. Transportability - An evaluation to determine the ability of the test item to withstand the forces which it will experience during normal handling and transporting.

i. Maintainability and Reliability Evaluation - That portion of the test which is concerned with the following: verification and appraisal of failures; determination and appraisal of maintenance characteristics and requirements; appraisal of design-for maintainability; appraisal of the maintenance test package; and, calculation of indicators which express the effects of the preceding aspects.

j. Safety - An evaluation to determine the safety characteristics and possible hazards of the test item.

k. Human Factors - An evaluation of the man-item relationship during installation, operation, maintenance and transportation of the test item, including the noise level generated, the adequacy of the design and layout of the controls, and any operability and accessibility design deficiencies.

l. Value Analysis - An evaluation to determine whether or not the test item has any unnecessary features which can be eliminated without affecting the technical performance or safety of the test item.

## 5.2 LIMITATIONS

This MTP is applicable to self-contained electrically operated test items in which humid air is drawn into the test item, passed through the moisture removal section and the dried air discharged into the space to be

MTP 10-2-068

3 July 1969

dehumidified. It is also limited to items employing either of the two major dehumidification processes described in paragraph 2.

6. PROCEDURES

6.1 PREPARATION FOR TEST

6.1.1 Initial Inspection

The test item shall be subject to the following upon its arrival at the test site:

6.1.1.1 Packaging Inspection

Visually inspect the test item container(s) and record the following:

- a. Evidence of packing damage or deterioration
- b. Identification markings including:
  - 1) Name of contractor
  - 2) Number and date of contract
  - 3) Date of manufacture
  - 4) All other pertinent markings
- c. For each package record the following:
  - 1) Weight.
  - 2) Length, width, and height.
  - 3) Cubage.
  - 4) Package contents, including mechanical and electrical drawings and manual containing operating, installation and maintenance data.

6.1.1.2 Test Item Inspection

Remove the test item from its package(s), visually inspect it and record the following when applicable:

- a. Evidence of defects in:
  - 1) Manufacturing
  - 2) Material
  - 3) Workmanship
- b. Evidence of damage.
- c. Evidence of wear.
- d. The presence of and correctness of identification tag(s) for all electrical requirements.
- e. Correlation of accompanying printed material with the test item's markings.
- f. Evidence of leakage of sealed units.

g. Adequacy of, and location of markings indicating location of power connections and inlet and outlet air.

6.1.2 Physical Characteristics

Determine the physical characteristics of the test item as described in the applicable sections of MTP 10-2-500.

6.1.3 Operator Training and Familiarization

Orient test personnel using the criteria of MTP 10-2-501 and record all pertinent data.

6.1.4 Instrumentation

The test item shall be instrumented for performance and/or durability tests as follows:

6.1.4.1 Temperatures

a. For both performance and durability test, install mercury-and-glass thermometers, accurate to 0.1°F to measure the wet-bulb and dry-bulb temperatures of Planes 1 and 3 (see Figure 2).

b. Thermocouple and associated recording equipment to measure:

- 1) Dry-bulb temperature of Plane 2 (see Figure 2) for performance tests.
- 2) Motor housing temperature for durability tests.

6.1.4.2 Relative Humidity

For the purpose of collecting accurate humidity data, install a psychrometer assembly consisting of a wet-bulb thermometer and dry-bulb thermometer with means for proper ventilation of the thermometer bulbs.

NOTE: A sling psychrometer or an air sampling tube with a motor driven fan are appropriate ventilating means. Air velocities across the sensing bulbs shall be maintained at approximately 1000 feet per minute, but not less than 700 feet per minute and appropriate means shall be provided for minimizing effects of radiant heating or cooling on the sensing bulbs.

6.1.4.3 Air Flow

a. The air flow velocity pressure shall be measured by use of inclined manometers in conjunction with pitot tubes installed in a standard traverse plan so that readings are taken in the center of equal areas for square ducts or the centers of equal annular areas (along two diameters) for round ducts.

NOTE: Additional information on air flow measurement schemes is

MTP 10-2-068  
3 July 1969

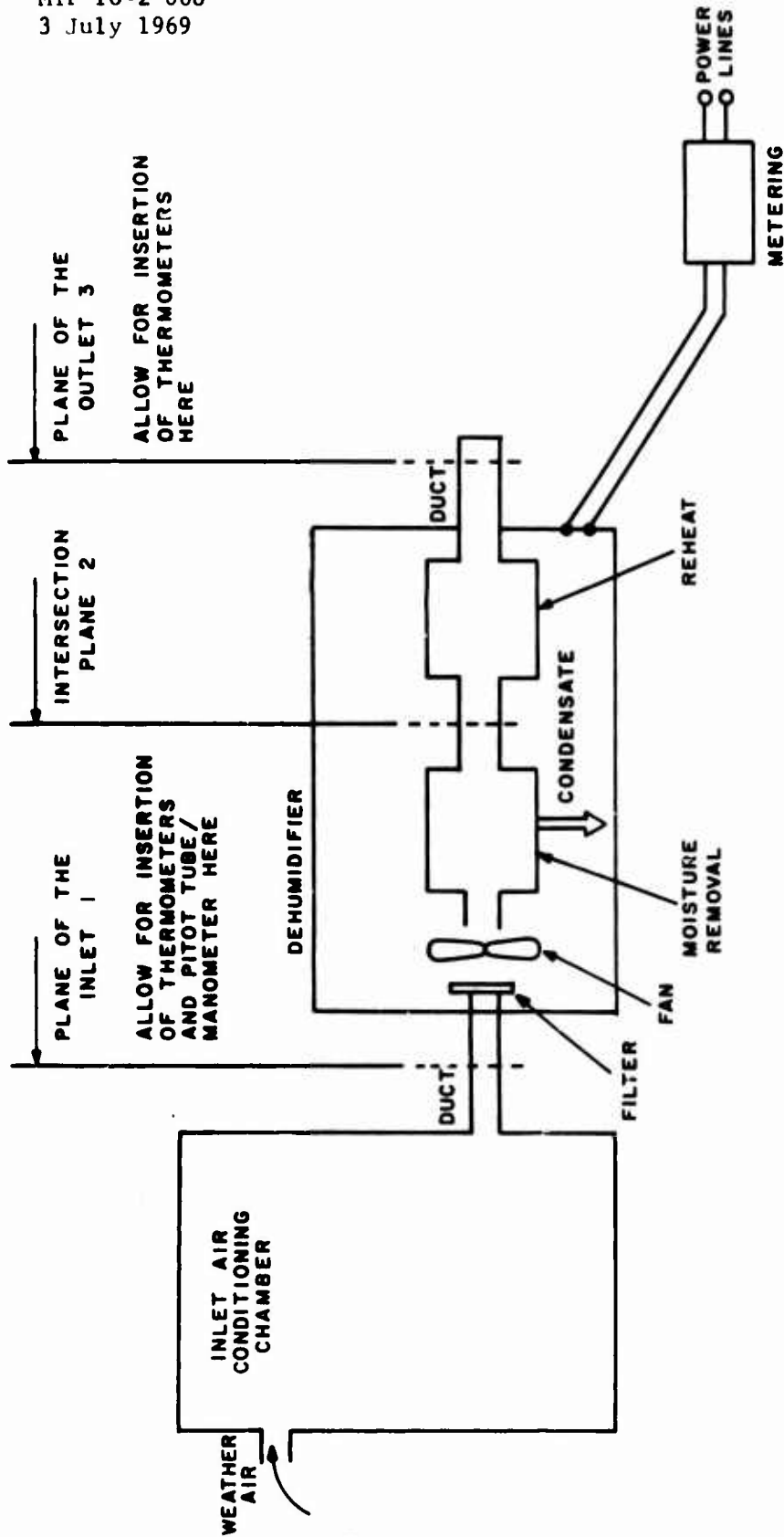

- NOTES 1. FOR REHEAT THE CONDENSER COILS OF THE REFRIGERATION SECTION ARE SOMETIMES USED
2. TEMPERATURES AT INTERNAL POINTS OF PLANE 2 MAY BE OBTAINED WITH AN APPROPRIATELY PLACED THERMOCOUPLE
3. TEMPERATURES AT PLANES 1,3 ARE OBTAINED BY INSERTING D.B. AND W.B. THERMOMETERS INTO THE DUCT
4. WHEN DEHUMIDIFIER IS THE CHEMICAL TYPE THE INTERNAL SECTION ABOVE IS REPLACED BY THE DESICCANT BED

FIGURE 2. GENERAL TEST SETUP

contained in reference 4F.

b. Install the pitot tubes at the required measurement planes in accordance with the general scheme outlined in Figure 2.

#### 6.1.4.4 Electrical Input Energy

a. Measure the electrical input energy to the test item and to the electrical heater(s) as applicable using watt-hour meters, accurate to 0.5 percent with the smallest scale graduation representing a maximum of 0.01 kilowatt hours.

b. In cases where watt-hour meters are unavailable, then the voltage and current shall be measured and the power to the test item can be calculated. Sample schemes for this type of metering are shown in Figure 3. Meter accuracy shall be within 0.5 percent.

#### 6.1.4.5 Line Voltage

Measure the line voltage to the test item using an appropriate voltmeter, accurate to within 0.5 percent with the smallest scale graduation representing a maximum of 2.0 volts.

#### 6.1.4.6 Heater Inputs and Outputs

a. For test items requiring steam for reactivation heat, the amount of steam supplied at the specified pressure shall be measured by means of a revolving drum condensate meter installed as required in the steam line.

b. For test items requiring gas or liquid fuel for the reactivation heating section, the amount of fuel required shall be measured by an appropriate flow meter, installed as required in the fuel line.

### 6.2 TEST CONDUCT

NOTE: Prepare an Equipment Performance Report (EPR) for all equipment failures.

#### 6.2.1 Preliminary Electrical Measurements

Perform the following prior to conducting operational tests, as applicable:

##### 6.2.1.1 Power Cables

a. Without the power cable(s) connected to the electrical service, set the test item main power switch to the "ON" position.

b. Using an ohmmeter, verify and record the following:

- 1) That the earth or building ground lead connected, effectively grounds the test item.
- 2) That each power lead of the power cable is not grounded.

MTP 10-2-068  
3 July 1969

1. DIRECT CURRENT MOTOR

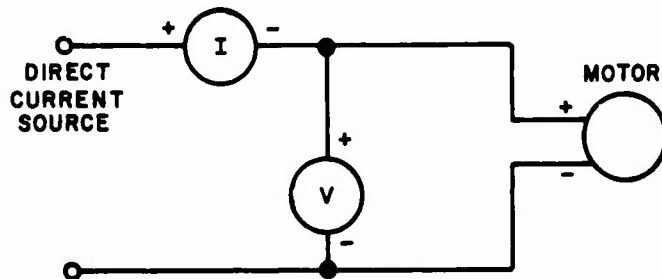

2. SINGLE PHASE ALTERNATING CURRENT

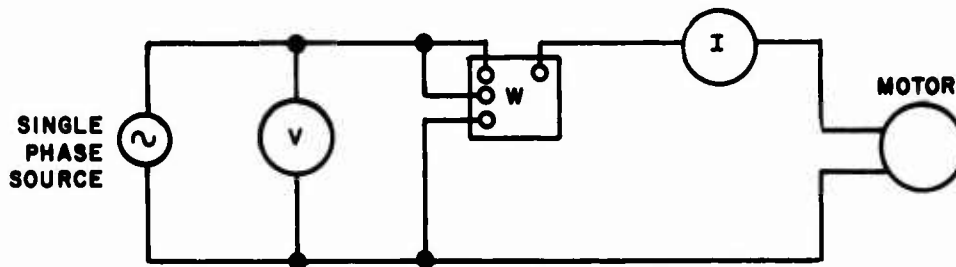

3. THREE PHASE ALTERNATING CURRENT

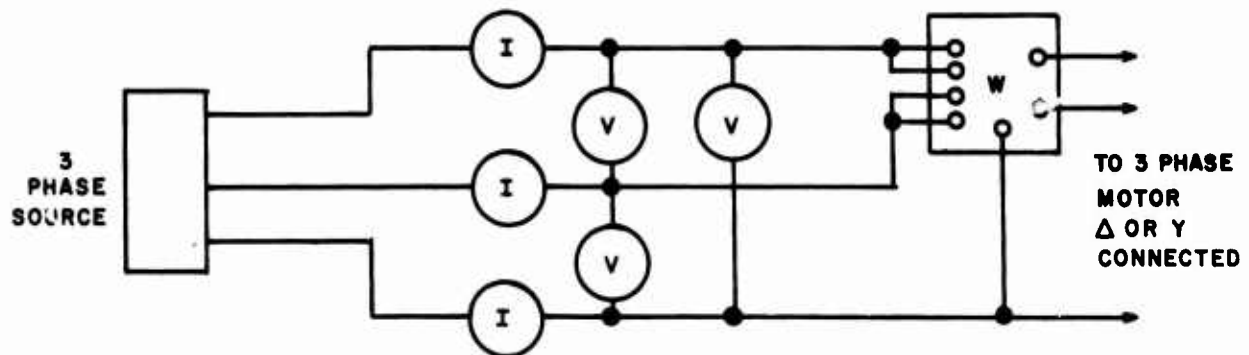

LEGEND  
I = AMMETER  
V = VOLTMETER  
W = WATTMETER

FIGURE 3 MOTOR POWER MEASUREMENT

#### 6.2.1.2 Motors

- a. Disconnect the power leads to all motors (drive motors, fan motors).
- b. Using a Wheatstone bridge, measure and record the direct current resistance of each motor winding.
- c. Reconnect the motor power leads.
- d. Using a megohmmeter, measure and record the insulation resistance between each motor winding (with its associated circuit) and the test item case (with all other circuits connected to the test item case).
- e. Test the dielectric strength of each electrical circuit by applying the test voltage between the circuit and ground with all other circuits connected to ground. (See Appendix A for the applicable requirements).

NOTE: In cases where shunt components with lower voltage ratings than the test voltages, disconnect those components for steps b and e.

#### 6.2.1.3 Electric Heaters

Conduct insulation resistance and dielectric strength tests on each reactivation (regeneration) heater and its associated circuits as described in MIL-H-22577.

#### 6.2.2 Operation and Performance

Conduct all operational testing at or near the standard atmospheric pressure of 29.92 inches of Hg.

##### 6.2.2.1 Installation and Run-In

a. Install the test item in a test room, observing the following general procedures:

- 1) Position the test item, in the test room with both the air inlet and outlet at least three feet from any wall or partition.
- 2) The test item shall be shielded to prevent direct heat radiation to or from other objects.
- 3) The circulation of air in the test rooms shall be such that the temperatures and relative humidity of the conditioned air will be uniform over the air outlet and shall be such that it will neither aid nor hinder the air circulated by the fan(s) in the test item.
- 4) Install the test instrumentation in accordance with paragraph 6.1.4 and as required for the individual test item.
- 5) Connect the test item inlet side to a source of air whose measurable characteristics (temperature, humidity, etc.) can be set and maintained at specific levels. (see Figure 2).

NOTE: For sorption-type items determine the air flow system used.

MTP 10-2-068  
3 July 1969

Figure 4 shows two commonly used techniques.

- 6) Connect the outlet side of the test item, by appropriate ducting to the workspace/room whose air it is intended to condition during the tests.
- 7) Where other inlets or outlets for air exist on the test item such as a weather air inlet or reactivation air outlet (sorption types) these shall be connected.
- 8) The test set-up shall be made so as to prevent inlet and outlet air from intermixing.

NOTE: Figure 2 shows a method for accomplishing this by connecting the inlet part to an environmental chamber while the outlet side is ducted into the work space with the duct serving as a mounting base for test instrumentation. This type of condition allows for a more valid measurement of test item performance since mixture of outlet with inlet air would prevent the maintenance of inlet conditions as specified.

- 9) If a means for collecting condensate is provided (refrigeration-type items) then it should be installed as required in normal service.

NOTE: Should there be only the provision for draining the condensate away from the test item proper, then means shall be provided for collecting the condensate in a substantially closed vessel to prevent re-evaporation.

- 10) In cases where steam is used for reactivation heating (on sorption-type items) exhaust the steam tube external to the test area.
- 11) Ensure that the test item is shielded from external air currents and against direct heat radiation to and from other objects.

b. Connect the test item power cable(s) and operate the test item for a minimum run-in period of 24 hours.

c. During the run-in period, observe the test item and record the following when applicable:

- 1) Improper test item operation including the functioning of:
  - a) Manual control equipment
  - b) Automatic control equipment
  - c) Monitors and indicators
  - d) Valves
  - e) Reactivation components
  - f) Safety devices
- 2) Undesirable test item characteristics including:

MTP 10-2-068  
3 July 1969

- a) Excessive vibration or noise.
- b) Excessive heating of components.
- c) Refrigerant leakage.
- d) Condensate leakage.
- e) Frost formation on the portion of the evaporator coil exposed to inlet air.
- f) Loosening of fasteners and hardware.

d. Verify that the installed instrumentation and associated recording devices are functioning as required.

e. Photograph the test item installation and the installed instrumentation.

#### 6.2.2.2 Operation

Measure and record the barometric pressure at the start and finish of each testing period.

##### 6.2.2.2.1 Refrigeration Type Items - Perform the following:

- a. Set the test item controls to the settings for which the specified conditions are able to be achieved.
- b. Establish the inlet air conditions, as required.

NOTE: Values shall be used which will allow a useful evaluation.  
e.g. 80°F D.B. temperature and 60% R.H.

c. Operate the test item for a minimum of six hours after inlet air conditions have become stabilized.

d. Measure and record the following at the start of the test run and at 30 minute intervals thereafter:

1) At plane I (see Figure 2):

- a) Dry-bulb air temperatures
- b) Wet-bulb air temperatures
- c) Air flow velocity pressures

2) Dry-bulb air temperatures at plane II (see Figure 2)

3) At plane III (see Figure 2):

- a) Dry-bulb air temperatures
- b) Wet-bulb air temperatures
- c) Air flow velocity pressures

4) Electrical energy input

5) Line voltage

f. Record the following at the completion of the test run:

- 1) Duration of the test run

MTP 10-2-068  
3 July 1969

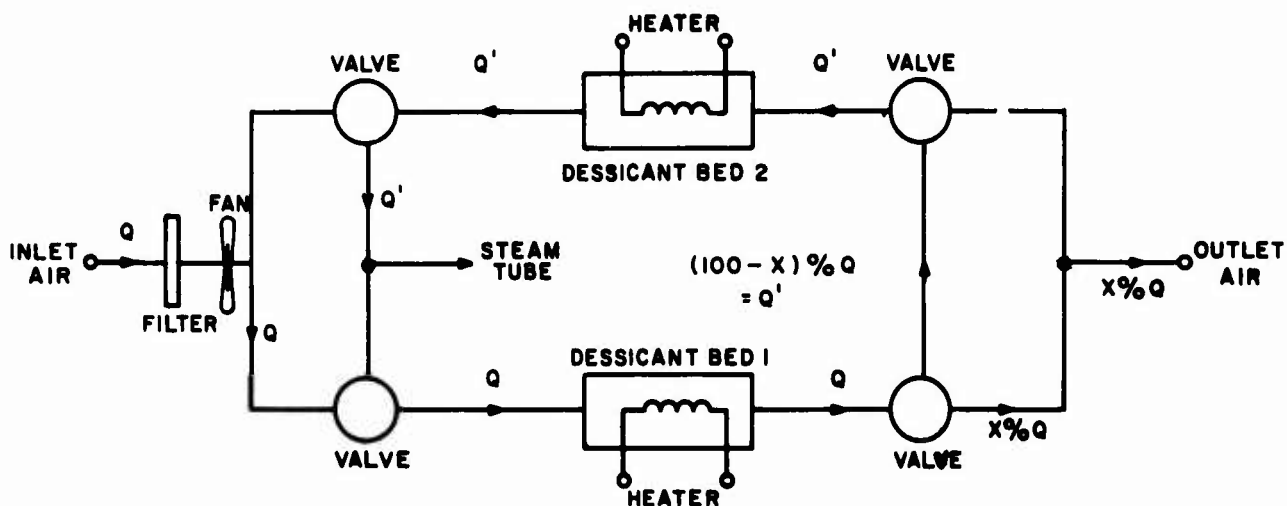

NOTE

1. Q'S INDICATE AIR FLOW
2. VALVES ARE SHOWN IN POSITIONS TO ALLOW BED NO.1 TO BE ADSORBING AND A PERCENTAGE OF INLET AIR TO BE FED BACK TO REACTIVATE BED NO.2. THE BEDS INTERCHANGE THEIR FUNCTIONS DURING PHASE 2 OF A COMPLETE CYCLE

FIGURE 4. A. THREE PORT SYSTEM WITHOUT WEATHER AIR

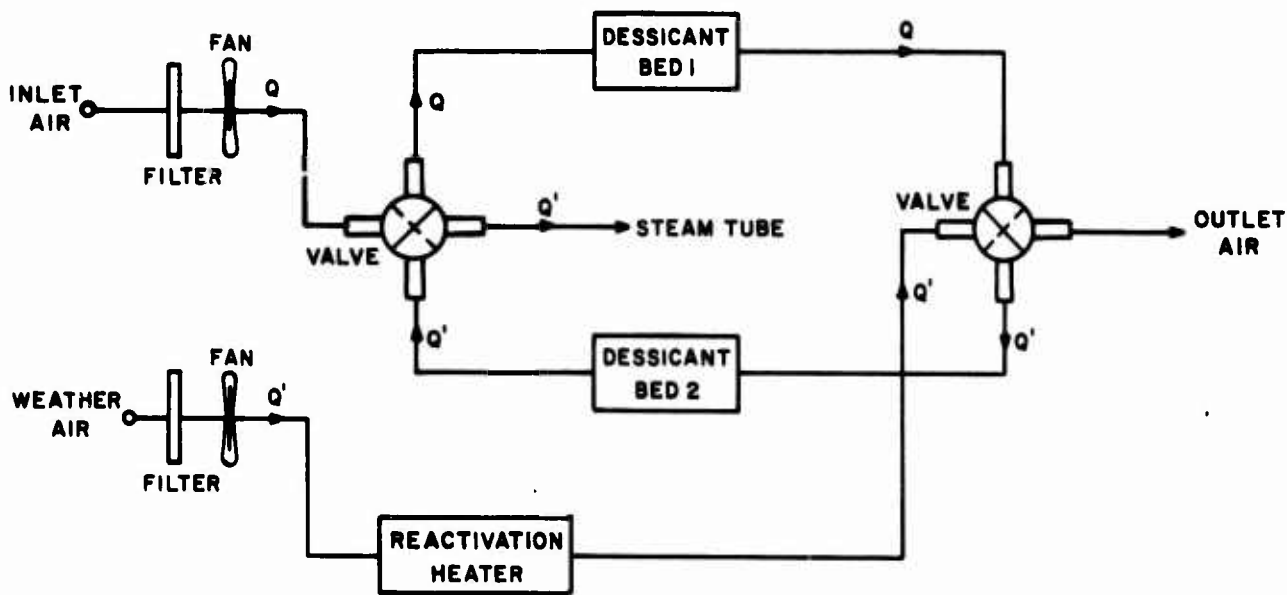

NOTE

1. Q'S INDICATE AIR FLOW
2. DASHED LINES IN VALVES SHOW POSITIONS FOR AIR FLOW WHEN Q PASSES THROUGH BED 2 AND Q' PASSES THROUGH BED 1

FIGURE 4 B. FOUR PORT SYSTEM WITH WEATHER AIR

2) Weight of the collected condensate

g. Repeat steps a through f for each set of conditions specified.  
i.e., 65°F, 60% R.H.

6.2.1.2.2 Sorption Type Items - Perform the following, as applicable:

- a. Set the test item controls and timing devices to the settings for which the specified conditions can be achieved.
- b. Establish the inlet air conditions, as required.
- c. Operate the test item for a minimum of six hours or for a minimum of three complete sorption/reactivation cycles, after inlet conditions have become stabilized.

- NOTE:
1. Continuous duty test items of various types employ sorption/reactivation processes simultaneously. A complete cycle shall mean that each section of the test item shall have completed both the sorption and reactivation phase.
  2. The start of the test run shall coincide with the activation of a sorbent bed. The time interval between data recording shall depend on the duration of the dehumidification and/or reactivation cycle phase.
  3. Space the time intervals between recordings to allow a full evaluation of the dynamic conditions of the outlet air, e.g., if the expected length of a use cycle is 30 minutes, then space the readings at three-minute intervals.

d. Measure and record the following at the start of each test run and at the specified intervals thereafter, as applicable.

- 1) At the conditioned air inlet:
  - a) Dry-bulb air temperatures
  - b) Wet-bulb air temperatures
  - c) Air flow velocity pressures
- 2) At the reactivation air inlet:
  - a) Dry-bulb air temperatures
  - b) Wet-bulb air temperatures
  - c) Air flow velocity pressures
- 3) At the conditioned air outlet:
  - a) Dry-bulb air temperatures
  - b) Wet-bulb air temperatures
  - c) Air flow velocity pressures
- 4) At the reactivation air outlet:
  - a) Dry-bulb air temperatures

MTP 10-2-068  
3 July 1969

- b) Wet-bulb air temperatures
- c) Air flow velocity pressures

- 5) Dry-bulb air temperatures in the reactivation heater section
- 6) Total electrical energy input
- 7) Reactivation heater input, as required
- 8) Line voltage

f. Record the following for each dehumidification and/or reactivation cycle phase, as applicable.

- 1) Phase identity
- 2) Duration of each cycle phase

g. Record the following at the completion of the test run:

- 1) Duration of the test run
- 2) Number of full cycles completed during the run

h. Repeat steps a. through g. for each set of conditions specified, i.e., 65°F, 60% R.H.

#### 6.2.3 Electromagnetic Interference

Subject the test item to the applicable electromagnetic interference procedures of MIL-STD-462, for class IIB equipment, using the equipment as described by MIL-STD-461.

NOTE: General interference definitions etc. are described in MIL-STD-463.

#### 6.2.4 Durability

a. Install the test item in its normal operating mode under the expected operating conditions.

b. Operate the test item continuously for a minimum of 100 hours.

c. Measure and record the following at the start of testing and at 10 hour intervals thereafter until the completion of the test.

- 1) Electrical power input
- 2) Line voltage
- 3) Inlet air dry-bulb temperature
- 4) Inlet air wet-bulb temperature
- 5) Outlet air dry-bulb temperature
- 6) Outlet air wet-bulb temperature
- 7) Motor housing temperatures

NOTE: The wet and dry-bulb temperatures of the inlet and outlet air shall be measured by means of psychrometers placed one foot in front of the respective openings.

MTP 10-2-068  
3 July 1969

d. Record all test item meter and/or indicator readings, as applicable at the measurement intervals of step c.

e. At the completion of testing, determine the effects of heat on the test item by performing the electrical measurements of paragraph 6.2.1.2 and 6.2.1.3 as applicable.

NOTE: The electrical checkout shall be performed immediately following the end of the test run while all components are very nearly at their operating temperatures.

f. Inspect the test item thoroughly and record any evidence of accelerated wear, fluid leakage or corrosion.

#### 6.2.5 Environmental Tests

The following tests shall be conducted as dictated by the technical requirements of the test item and at the conditions specified if otherwise directed by the QMR, SDR or TC.

##### 6.2.5.1 Temperature Tests

###### 6.2.5.1.1 High Temperature Tests - Perform the following:

a. Subject the test item to the temperature conditions of Procedure I of MIL-STD-810B, Method 501.

b. At the completion of step a, perform the following:

- 1) Visually inspect the test item for and record evidence of damage or deterioration.
- 2) Subject the test item to the electrical measurements of paragraphs 6.2.1.2 and 6.2.1.3.
- 3) Subject the test item to the applicable performance procedures of paragraph 6.2.2.2.

###### 6.2.5.1.2 Low Temperature Tests - Perform the following:

a. Subject the test item to the temperature conditions of MIL-STD-810B, Method 502.

b. At the completion of step a, repeat the procedures of paragraph 6.2.5.1.1.b.

##### 6.2.5.2 Fungus Test

a. Subject the test item to the fungi exposure conditions of MIL-STD-810B, Method 508.

MTP 10-2-068  
3 July 1969

b. At the completion of step a, repeat the procedures of paragraph 6.2.5.1.1.b.

6.2.5.3 Dust Test

a. Subject the test item to the dust conditions of MIL-STD-810B, Method 510.

b. At the completion of step a, repeat the procedures of steps b.1 and b.3 of paragraph 6.2.5.1.1.

6.2.5.4 Salt-Fog Test

a. Subject the test item to the humidity conditions of MIL-STD-810B, Method 509.

b. At the completion of step a, repeat the procedures of paragraph 6.2.5.1.1.b.

6.2.5.5 Rain Test

a. Subject the test item to the rain conditions of MIL-STD-810B, Method 506.

b. At the completion of step a, perform the following:

- 1) Visually examine the test item for and record evidence of signs of damage or deterioration.
- 2) Record evidence of water penetration.

6.2.6 Balance Test

a. Place the test item in its normal operating condition/position and attach a vibration amplitude measuring set, as required, to take a measurement of step b.

b. Measure and record the amplitude of vibration in at least two places on each exposed face of the dehumidifier.

c. Record the location of each measuring point.

NOTE: Measurements should be made at locations which are remotely removed from the point or points at which the dehumidifier is mechanically secured to its mounting.

6.2.7 Transportability

a. Determine the transportability of the test item as described in the applicable sections of MTP 10-2-503 including the following:

MTP 10-2-068  
3 July 1969

- 1) The shock test shall be performed using Procedure I of Method 516.
  - 2) The vibration test shall be performed using Procedure X of Method 514.
- b. At the completion of each test of step a, perform the following:
- 1) Visually inspect the test item for evidence of damage or deterioration.
  - 2) Subject the test item to the electrical measurements of paragraph 6.2.1.
  - 3) Subject the test item to the applicable performance procedures of paragraph 6.2.2.2.

#### 6.2.8 Maintainability and Reliability Evaluation

Evaluate the maintenance-related factors of the test item as described in MTP 10-2-507 with emphasis on the following:

- a. Organizational (O), Direct Support (F), and General Support (H) maintenance requirements.
- b. Operator through General Support Maintenance Literature.
  - c. Repair parts.
  - d. Tools.
  - e. Test and handling equipment.
  - f. Calibration and maintenance facilities.
  - g. Personnel skill requirements.
  - h. Maintainability.
  - i. Reliability.
  - j. Availability.

#### 6.2.9 Safety

During conduct of this MTP test personnel shall perform the following:

- a. Observe and record the following:
- 1) Safety hazard(s), if any and probable cause
  - 2) Steps taken to alleviate safety hazard(s)
- b. Inspect the test item and record any failure to meet the applicable safety requirements of UL-474-1968 (reference 4U) and USAS B9.1 - 1964 (reference 4 O) with emphasis on the following:
- 1) Electrical parts shall be so located or enclosed so that suitable protection against accidental contact with un-insulated energized circuits is provided.
  - 2) All internal wiring shall be protected against heat and

MTP 10-2-068  
3 July 1969

- contact with moving parts.
- 3) Where connections are made to internal wiring a barrier type terminal board or equivalent shall be used for secure lead attachment and protection against accidental contact of leads attached adjacent to each other.
  - 4) Where line cords are used they shall be of sufficient current carrying capacity, shall be protected against rubbing at access ports by insulated bushings and shall be sufficiently strain relieved to withstand approximately five pounds of pull.
  - 5) Where line fuses are used they shall be of a value consistent with the requirements of the dehumidifier.
  - 6) Where switches are used they shall be of sufficient current capacity and mounted so as not to allow movement.
  - 7) All metal parts shall be electrically bonded and grounded to prevent static electrical buildup.
  - 8) The materials used in the motors and dehumidifier shall be inherently nonflammable and nonexplosive.
  - 9) Where the normal operating temperature of the motor(s) shall be sufficient to cause a burn the motor shall have a plate attached stating this fact.
  - 10) All moving parts of the set shall be enclosed to avoid accidental contact when the dehumidifier is in its operating position.
  - 11) All propellers or impellers shall be securely attached to the motor shafts.
  - 12) All external surfaces and internal surfaces (those exposed during maintenance) shall have no sharp edges.
  - 13) Where a thermal overload is provided for a motor it shall be tested for operation and the method of reset (manual or automatic) or verified.
  - 14) The blades or impellers and shafting shall be sufficiently strong and designed with adequate clearance to prevent contact with casings or prevent distortion under conditions of deposit loading or other factors.
  - 15) Where the dehumidifier is to be used with explosive vapors the rotating elements shall be constructed of a non-ferrous or non-sparking material.
  - 16) Where capacitors are used they shall be housed in a suitable enclosure which will provide protection and also prevent the emission of flame or molten material in the event of a failure.
  - 17) Where the dehumidifier is equipped with internal heater, they shall be protected against overheat in the event of an air flow failure.
  - 18) Refrigeration systems shall be equipped with pressure safety valves particularly on the high side of the compressor.
  - 19) Condensation cooling surfaces shall be non-corrosive.
  - 20) The means of collecting, storing, or disposing of condensate shall be such that its path is unimpeded by other internal elements.

MTP 10-2-068  
3 July 1969

- 21) Freeze up of the evaporator coil shall be prevented by detecting excessively low temperatures and stopping the compressor operation.

c. Check for and record presence of ground voltage in frame, ducting, etc.

#### 6.2.9 Human Factors Evaluation

a. Determine the man-item considerations as described in the applicable sections of MTP 10-2-505 and as follows:

- 1) Prepare operator questionnaires to obtain test personnel comments on:
  - a) Test item component accessibility.
  - b) Ease of assembling, operating, maintaining, dismantling, and handling.
  - c) Operator comfort.
- 2) Supervisor personnel shall observe and record the following:
  - a) Any difficulties, such as excessive effort or awkwardness in the operation of controls.
  - b) Difficulties in accessibility to or operation of the individual components of the test item.
- 3) Effects of noise on personnel using the criteria of HEL Standard S-1-63B.

b. Determine the test item noise level, and noise location as follows:

- NOTE:
1. The noise level may be obtained during the operation and performance tests of Paragraph 6.2.2 if the ambient noise levels are sufficiently low.
  2. The set-up will be located preferably in a reverberant or semi-reverberant room for nonduct test items and for duct test items, provided the room can accommodate the test item. The test item may also be set up out-of-doors. However, in either case, the location must be qualified on the basis of measurements revealing the ambient sound pressure levels.
- 1) Mount the test item in its normal operating mode, on a non-resonant stand at the geometric center of the room or at least six feet from any sound reflecting surfaces.
  - 2) Prepare sound measuring equipment for the test as follows:
    - a) Position a microphone at a point three feet from the approximate center of the test item observing the following restrictions:

MTP 10-2-068

3 July 1969

- (1) The microphone should be oriented for maximum pickup.
  - (2) There should be no obstruction between it and the test item, and where possible the measuring equipment should be remotely operated (outside the room).
  - (3) The measuring locations for the microphone shall be along a circular path whose radius is three feet measured to the approximate center of the test item.
  - (4) No measurements shall be taken at plus or minus 30° with respect to the normal leading to an open inlet or outlet.
  - (5) Use measuring locations approximately every 20° taken with respect to an arbitrary reference point.
- b) Calibrate a sound level meter and set the weighting network switch of the meter to the "flat response" or C position.
- 3) Apply power to the dehumidifier.
  - 4) Measure and record the highest sound pressure level in each band over all of the bands (See Table II).

TABLE II  
Series 2 Frequency Analyses

BAND	FROM	TO	CENTER FREQUENCY*
1	45	90	63
2	90	180	125
3	180	355	250
4	355	710	500
5	710	1400	1000
6	1400	2800	2000
7	2800	5600	4000
8	5600	11,200	8000

\*Defined as geometric mean of cut-off frequencies.

- 5) For the point of highest sound pressure in each band, remove power from the test item and measure and record the ambient noise level.

#### 6.2.11 Value Analysis

During the conduct of the test observe and record any unnecessary costly, or nice to have features of the test item, as stated in USATECOM Regulation 700-1, which can be eliminated without affecting the operation, maintenance, safety or durability of the test item.

#### 6.3 TEST DATA

6.3.1 Preparation for Test

6.3.1.1 Initial Inspection

6.3.1.1.1 Packaging Inspection -

Record the following:

- a. Evidence of package damage or deterioration
- b. Identification markings

- 1) Name of contractor
- 2) Number and date of contract
- 3) Date of manufacture
- 4) Other pertinent markings

c. For each package record the following:

- 1) Weight, in lbs.
- 2) Length, width and height, in inches
- 3) Cubage, in ft<sup>3</sup>
- 4) Package contents

6.3.1.1.2 Test Item Inspection -

Record the following:

a. For the test item, defects in the following:

- 1) Manufacturing
- 2) Material
- 3) Workmanship

b. Evidence of damage.

c. Evidence of wear.

d. Presence of and correctness of identification tag(s) with the electrical requirements data on the motor.

e. Correlation of accompanying printed material with the test item's markings.

f. Evidence of leakage of sealed items.

g. Adequacy of location and markings of power connector and air inlet and outlet tags.

6.3.1.2 Physical Characteristics

Record data collected as described in the applicable sections of MTP 10-2-500.

6.3.1.3 Operator Training and Familiarization

Record pertinent data collected as described in the applicable sections

MTP 10-2-068

3 July 1969

of MTP 10-2-501.

6.3.2 Test Conduct

6.3.2.1 Preliminary Electrical Measurements

6.3.2.1.1 Power Cables -

Record verification of the following:

- a. Adequacy of grounding
- b. That each power lead, of the cable, is not grounded

6.3.2.1.2 Motors

Record the following for each motor:

- a. Motor under test (fan, refrigeration, etc.)
- b. Motor type (universal, induction, etc.)
- c. Direct current resistance of each winding in ohms
- d. Insulation resistance in megohms:

- 1) Between each winding and the case.
- 2) Between each winding and all other circuits connected to the case.

e. Dielectric strength between each winding (and its associated circuit) and all other windings and their associated circuits connected to ground, in megohms.

6.3.2.1.3 Electric Heaters -

Record the following of each heater as indicated in MIL-H-22577:

- a. Insulation resistance in megohms
- b. Dielectric strength in megohms

6.3.2.2 Operation and Performance

6.3.2.2.1 Installation and Run-In -

a. Record the following:

- 1) Malfunctions observed
- 2) Undesirable test item characteristics

b. Retain all photographs

6.3.2.2.2 Operation -

3 July 1969

- a. Record the barometric pressure at the start and finish of each test run, in inches of Hg.
- b. Record the following input air conditions:
  - 1) Temperature in °F
  - 2) Relative humidity in %
- c. Record the following for refrigeration type items:
  - 1) At the start and at 30 minute intervals throughout the test run:
    - a) At plane I:
      - (1) Dry-bulb air temperatures in degrees F.
      - (2) Wet-bulb air temperatures in degrees F.
      - (3) Air flow velocity pressure in inches of Hg.
    - b) Dry-bulb air temperatures at plane II.
    - c) At plane III:
      - (1) Dry-bulb air temperatures in degrees F.
      - (2) Wet-bulb air temperatures in degrees F.
      - (3) Air flow velocity pressures in inches of Hg.
    - d) Electrical energy input in kilowatt-hours.
    - e) Line voltage.
    - f) Time at which each data set was recorded in hours and minutes.
  - 3) Record the following at the completion of each test run:
    - a) Duration of test run in hours
    - b) Weight of collected condensate in pounds
- c. Record the following for sorption type test items, as applicable:
  - 1) Type of air flow system used (valve system, rotating sorbent/ reactivation beds, etc).
  - 2) Type of sorbent reactivation air heating used (electrical, steam, gas or liquid fuel, etc.).
  - 3) At the start and at the specified intervals throughout each test run:
    - a) At the conditioned air inlet:
      - (1) Dry-bulb air temperature in degrees F.
      - (2) Wet-bulb air temperatures in degrees F.
      - (3) Air flow velocity pressures in inches of Hg.
    - b) At the reactivation air inlet:

MTP 10-2-068  
3 July 1969

- (1) Dry-bulb air temperatures in degrees F.
  - (2) Wet-bulb air temperatures in degrees F.
  - (3) Air flow velocity pressures in inches of Hg.
- c) At the conditioned air outlet:
- (1) Dry-bulb air temperatures in degrees F.
  - (2) Wet-bulb air temperatures in degrees F.
  - (3) Air flow velocity pressures in inches of Hg.
- d) At the reactivation air outlet:
- (1) Dry-bulb air temperatures in degrees F.
  - (2) Wet-bulb air temperatures in degrees F.
  - (3) Air flow velocity pressures in inches of Hg.
- e) Dry bulb air temperatures in the reactivation heater section in degrees F.
- f) Total electrical energy input in kilowatt-hours.
- g) Reactivation heater input as required:
- (1) Electrical energy in kilowatt-hours
  - (2) Steam consumption in pounds
  - (3) Gas or liquid fuel consumption in pounds (at nominal pressure).
- h) Line voltage.
- i) Time at which each data set was recorded in hours and minutes.
- 4) For operating cycle phase, as required:
- a) Phase identity (dehumidification, reactivation, or simultaneous DH/react).
  - b) Duration of each cycle phase in minutes.
- 5) Record the following at the completion of each test run:
- a) Duration of the test run in hours
  - b) Number of full cycles completed during the run

#### 6.3.2.3 Electromagnetic Interference

Record electromagnetic interference data collected as described in the applicable sections of MIL-STD-462.

#### 6.3.2.4 Durability

a. Record the following at the start of testing and at 10 hour intervals until completion of operation:

- 1) Time of reading in hours and minutes
  - 2) Electrical power input in kilowatt hours
  - 3) Line voltage
  - 4) Inlet air dry-bulb temperature in degrees F.
  - 5) Inlet air wet-bulb temperature in degrees F.
  - 6) Outlet air dry-bulb temperature in degrees F.
  - 7) Outlet air wet-bulb temperature in degrees F.
  - 8) Motor housing temperatures in degrees F.
  - 9) Test item meter and/or indicator readings, as applicable
- b. Record the duration of testing in hours.
- c. Record the following at the completion of testing:
- 1) Electrical measurement data collected as described in paragraph 6.2.1.2 and 6.2.1.3.
  - 2) Evidence of accelerated wear, fluid leakage or corrosion.

#### 6.3.2.5 Environmental Tests

##### 6.3.2.5.1 Temperature Tests -

Record the following for each test performed:

- a. Storage temperature in °F.
- b. Extreme operating temperature in °F.
- c. Evidence of damage or deterioration.
- d. Electrical measurement data collected as described in paragraph 6.2.1.2 and 6.2.1.3.
- e. Performance data collected as described in the applicable sections of paragraph 6.2.2.2.

##### 6.3.2.5.2 Fungus Test -

Record the following:

- a. Evidence of damage or deterioration.
- b. Electrical checkout data collected as described in paragraphs 6.2.1.2 and 6.2.1.3.
- c. Performance data collected as described in the applicable sections of paragraph 6.2.2.2.

##### 6.3.2.5.3 Dust Test -

Record the following:

- a. Evidence of damage or deterioration.
- b. Performance data collected as described in the applicable sections of paragraph 6.2.2.2.

##### 6.3.2.5.4 Salt-Fog Test -

MTP 10-2-068  
3 July 1969

Record the following:

- a. Evidence of damage or deterioration.
- b. Electrical measurement data collected as described in paragraphs 6.2.1.2 and 6.2.1.3.
- c. Performance data collected as described in the applicable sections of paragraph 6.2.2.2.

6.3.2.5.5 Rain Test -

Record evidence of the following:

- a. Damage or deterioration
- b. Water penetration

6.3.2.6 Balance Test

Record the following:

- a. Location of measuring points
- b. Vibration level at each measuring point

6.3.2.7 Transportability

Record the following for each test performed:

- a. Test performed (shock, rail, etc.).
- b. Evidence of damage or deterioration.
- c. Electrical measurement data collected as described in paragraph 6.2.1.
- d. Performance data collected as described in the applicable sections of paragraph 6.2.2.2.

6.3.2.8 Maintainability and Reliability Evaluation -

Record data as described in the applicable sections of MTP 10-2-507.

6.3.2.9 Safety

- a. Record the following during the conduct of testing:
  - 1) Any condition which could cause a safety hazard
  - 2) Steps taken to eliminate the hazard
- b. Record any test item safety features or devices not in accordance with the following as applicable:
  - 1) UL-474-1968, Standards for Safety, Dehumidifiers, Underwriters Laboratories.
  - 2) USAS B9.1-1964, Safety Code for Mechanical Refrigeration.

- c. Record presence of ground voltage on frames, ducts, etc.

#### 6.3.2.10 Human Factors Evaluation

Record the following:

- a. Data, collected as described in the applicable sections of MTP 10-2-505.
- b. Observations made by supervisory personnel during the period of testing, including:

- 1) Any difficulties such as excessive effort or awkwardness necessary for operation of controls.
- 2) Any difficulties due to the inaccessibility to maintainable or replaceable components.

- c. Operator questionnaire data relative to operator comfort, component accessibility and ease of assembling, maintaining, operating, dismantling and handling the test item.

- d. Any adverse effects on test personnel due to noise generated by the test item.

- e. For each position at which noise measurements are made:

- 1) Location with respect to the front center of the test item in degrees, clockwise.
- 2) Highest sound pressure in each band.
- 3) Frequency of highest sound pressure in each band.
- 4) Ambient sound pressure for each band.

#### 6.3.2.11 Value Analysis

Record the following:

- a. Any unnecessary, costly or "nice-to-have" features of the test item which could be eliminated without affecting the operation, maintenance, or safeness of the test item.

- b. Reason for recommendations to eliminate features.

### 6.4 DATA REDUCTION AND PRESENTATION

#### 6.4.1 General

a. Data obtained from all subtests covered by applicable MTP's shall be summarized, compared with the technical performance characteristics specified in the QMR's, SDR's, or other specifications, and evaluated according to procedures described in those applicable MTP's. Appropriate charts, graphs, and tabulated summaries shall be used to present the data in a clear manner.

Calculations shall be performed as specified by the individual MTP's, wherever applicable, and all photographs, motion pictures, and illustrative material shall be suitably identified.

MTP 10-2-068  
3 July 1969

b. All data not evaluated as described in a above or paragraphs 6.4.2 through 6.4.6 shall be tabulated and summarized as appropriate and compared with the test items applicable technical performance characteristics when required.

#### 6.4.2 Preliminary Electrical Measurements

Present the data from all measurements in tabular form and compare the values for resistance, insulation resistance and dielectric strength with those obtained for the respective circuits at the completion of durability testing, the individual environmental tests and the individual transportability tests.

#### 6.4.3 Operation and Performance

a. Calculate the mean barometric pressure for all operational test runs and where significant differences from standard atmospheric (29.92 in. Hg) are found calculate the temperature corrections to be applied so that data may be retrieved from the psychrometric chart for standard atmospheric pressure.

b. Calculate the mean wet and dry-bulb temperatures for each measurement location for each test run.

c. Calculate the average air flow rates for each measurement location from the velocity pressure data taken. Use the required conversion factors to calculate the flow rates in feet per minute. Since air at or near atmospheric pressure can be treated, substantially, as an incompressible fluid, simplified formulas can be used with sufficient accuracy. e.g.

$$V_m = 1096.5 \sqrt{\frac{h_{aw}}{p}}$$

where:

$V_m$  = velocity in feet per minute

$h_{aw}$  = velocity pressure in inches of  $H_2O$

$p$  = density of air in  $lbs/ft^3$   
(standard =  $0.075 lbs/ft^3$ )

In addition a diagram or photograph of the pitot tube traverse should be presented with the data for each location.

d. Calculate the volumetric flow rate in cubic feet per minute at each measurement position for each test run, using the cross section area at the air velocity measurement plane.

e. Using the average wet and dry bulb temperatures calculated for each measurement position, determine the following properties of the air using the ASHRAE Psychrometric Chart:

- 1) Relative humidity, in percent (note the units used on the chart, however).
- 2) Volume, in cubic feet per pound of dry air.
- 3) Humidity ratio (specific humidity) in pounds of water vapor per pound of dry air.
- 4) Enthalpy in BTU per pound of dry air.

#### 6.4.3.1 Refrigeration Type Items

a. Assuming a relative humidity of 100% at the plane II measuring position, use the psychrometric chart to determine the following:

- 1) Specific humidity in pounds of water per pound of dry air.
- 2) Enthalpy in BTU per pound of dry air.

b. Calculate the mass flow rate for the air passing planes I and III in pounds of dry air per minute.

c. Calculate the weight of the accumulated condensate for each test run as follows:

$$m_c = m(W_1 - W_2)60T$$

where:

$m_c$  = weight of condensate in pounds

$m$  = mass flow rate in pounds of air per minute

$W_1$  = specific humidity at plane I in pounds of water per pound of dry air.

$W_2$  = humidity ratio at plane II

$T$  = duration of test run in hours

d. Compare the calculated value of the condensate weight with the measured weight of the condensate. Using the dry-bulb temperature at plane II as the temperature of the condensate obtain the enthalpy of the condensate in BTU per pound from the Table of Thermodynamic Properties of Moist Air.

e. Compare all of the values measured and derived for each test condition with the technical requirements of the test item and especially note those cases where marked discrepancies occur.

f. Evaluate the overall performance and economy of the test item by determining the following:

$$\begin{aligned} \text{Rated Capacity} &= \frac{\text{Condensate (in pounds)} \times 24}{\text{duration of test (hours)} \times 1.04} \\ &= \frac{\text{Condensate (pints)} \times 24}{\text{duration of test (hours)}} = \text{Pints/24 hours} \end{aligned}$$

$$\text{Rated Input} = \frac{\text{Input power during test period (watthrs.)} \times 24}{\text{duration of test (hours)}} = \frac{\text{Watthrs.}}{24 \text{ hrs.}}$$

$$\text{Performance Factor} = \frac{\text{Rated Capacity}}{\text{Rated Input}} = \text{Pints/watthours}$$

NOTE: In cases where instrumentation, as shown in Figure 3, was used to obtain power measurements, rather than measuring the energy input directly with a watthour meter, the power and the energy consumed must be calculated for each run.

#### 6.4.3.2 Sorption Type Items

MTP 10-2-068

3 July 1969

- a. Data from all use cycle and cycle phases shall be compared for all test runs in order to verify that the data are repetitive for all cycles.
- b. The average duration of each cycle phase shall be determined; as applicable, and the ratio of the dehumidification phase to the reactivation phase shall be calculated.
- c. The values obtained for the humidity ratio at the conditioned air outlet for each test run shall be plotted against time and the resultant curves compared and examined to verify that they show the following:
  - 1) Humidity values at the start of a cycle are lowest and increase during the course of each cycle due to the deterioration of the dehydrating property of the sorbent material.
  - 2) Humidity values at the end of each cycle shall not be higher than the specified design value.
- d. Calculate an approximate value for the weight of water vapor, in pounds, removed from the entering air for each dehumidification cycle and each test condition.

NOTE: The method of approximation will be determined by the characteristics of the sorbent material under a given set of operating conditions. An approximate value for the average rate of water removal can be assigned from the curves generated from the test data or standard mathematical methods can be used to calculate the weight of water removed over a given time span.

- e. Determine the total amount of water removed from the entering air for each test run.
- f. For test items having reactivation systems, determine the total amount of reactivation energy supplied to the reactivation heater for each test run.

NOTE: Calculate the reactivation energy from the data taken or use the measured value for electric heaters.

- g. Determine the reactivation energy required per pound of water removed from the entering air for each test run.

NOTE: Energy units shall be convenient for the type of reactivation process employed.

- h. Determine the rated capacity of the test item for each test run as follows:

$$\begin{aligned} \text{Rated Capacity} &= \frac{\text{H}_2\text{O removed in pounds} \times 24}{\text{duration of the test run} \times 1.04} \\ &= \text{Pints/24 hours.} \end{aligned}$$

- i. Determine the electrical input rating for the test item for each

test run as follows:

$$\text{Rated Input} = \frac{\text{kilowatthours} \times 1000}{\text{Duration of the test run, hours}} = \text{watts/hour}$$

j. Determine the overall input rating for items which do not use electric reactivation heat by combining the reactivation input with the electrical input, in watts.

k. Determine the performance factor for the test item for each test run as follows:

$$\text{Performance Factors} = \frac{\text{Rated Capacity}}{\text{Overall Input}} = \text{pints/watt}$$

l. Compare all measured and derived values for each test condition with the technical requirements of the test item and note those cases where marked discrepancies occur.

#### 6.4.4 Electromagnetic Interference

Process the test data and present the results as described in the applicable sections of MIL-STD-461 and MIL-STD-462.

#### 6.4.5 Durability

a. Present all data recorded during the test run in chronological order. Values which differ markedly from one data point to another should be circled.

b. Calculate the final temperature for each motor winding as follows:

$$t_h = (R_h/R_c) (K + t_c) - K$$

where:

$t_h$  = final temperature of the motor winding in °F.

$R_h$  = hot winding resistance, in ohms,

$R_c$  = cold winding resistance, in ohms, (from preliminary data)

$T_c$  = cold winding temperature in °F (ambient temperature)

$K$  = constant (90.1 for copper, 365.8 for aluminum)

c. Determine the temperature rise of each winding and compare it with the allowable temperature rise for each insulation class:

- 1) Class A insulation - not more than 40°C rise
- 2) Class B insulation - not more than 60°C rise
- 3) Class C insulation - not more than 15°C rise

d. List any indication of accelerated wear as indicated by test item inspection.

#### 6.4.6 Human Factors Evaluation

Prepare a table showing measurement locations, the highest noise readings in each band and the ambient noise. Include a column for corrected noise readings with the new readings to be determined in the following manner.

MTP 10-2-068  
3 July 1969

- a. If the difference between the noise reading and the ambient reading is 3 decibels or less mark corrected reading "indeterminate".
- b. If the difference is between 4 and 10 decibels consult Table III.

TABLE III

CORRECTIONS FOR AMBIENT SOUND PRESSURE LEVELS

Difference in decibels between sound pressure level measured with sound source operating and ambient sound pressure level alone	4	5	6	7	8	9	10
Correction, in decibels, to be subtracted from sound pressure level measured with sound source operating to obtain sound pressure level due to sound source alone.	2.2	1.7	1.3	1.0	0.8	0.6	0.4

- c. If the difference is greater than 10 decibels no corrections are necessary.

Circle those readings which are out of limit as indicated by Table 2 of Standard S-1-63B, Maximum Noise Level for Army Materiel Command Equipment, June 1965

6.4.7 Safety

A preliminary report shall be submitted in accordance with USATECOM Regulation 385-6, based on the data collected related to safety.

APPENDIX A  
MOTOR DIELECTRIC STRENGTH TESTS

**General Requirements:** This specification is applicable before and after a prolonged run period. The frequency of the test voltage shall be 25-60 Hz and the peak value shall be the specified test voltage multiplied by  $\sqrt{2}$ . The test voltage shall be applied for (1) minute except that an equivalent test can be conducted for (1) second if the test voltage is 1.2 times that voltage used for the (1) minute test.

Motor Types

- A. Universal Motors - The high potential test for all motors regardless of horsepower and for operation upon circuits not exceeding 250 volts shall be made by applying 900 VRMS.
- B. Direct Current and Induction Motors -

- 1. Motors rated 1/2 horse power and larger.

- a. Apply 1000 VRMS plus twice the rated voltage of the motor windings not connected to the line.

**Exceptions:** The standard test voltage for secondary windings of wound rotors of induction motors shall be 1000 VRMS plus twice the maximum voltage induced between slip rings on open circuit at standstill (or running if under this condition the voltage is greater) with primary voltage applied to the stator terminals as in service. Since the voltage induced in the rotor is a function of both the speed of the rotor and the voltage impressed on the stator, the test voltage applied to the rotor shall be determined from that combination of those two conditions which give the highest voltage included in the rotor.

For reversing motors the test voltage shall be 1000 VRMS plus four times the maximum voltage induced between slip rings on open circuit at standstill with rated primary voltage applied to the stator terminals.

- 2. Motors Rated at Less than 1/2 Horsepower

- a. For motors rated less than 1/2 horsepower and operated by circuits of less than 250 volts the test voltage shall be 900 VRMS. Above 250 volt operation the test voltage shall be 1000 VRMS plus twice the motor rated voltage.
- b. For motors rated less than 1/2 horsepower where armatures or rotors have insulated windings not connected to the line the test voltage shall be 900 VRMS.