

# USAETL ARCHIVES COPY

8 MAR 1970

AD 721 634

## PRELIMINARY DESIGN REPORT

Prepared for:

U. S. ARMY ENGINEER RESEARCH AND  
DEVELOPMENT LABORATORIES  
GIMRADA  
Fort Belvoir, Virginia

CLASSIFIED  
UNCLASSIFIED  
EXCLUDED

Contract No. DA-44-009-AMC-1246(X)

26 October 1966

Reproduced by  
NATIONAL TECHNICAL  
INFORMATION SERVICE  
Springfield, Va 22151



121

**PRELIMINARY DESIGN REPORT**

**Prepared for:**

**U. S. ARMY ENGINEER RESEARCH AND  
DEVELOPMENT LABORATORIES  
GIMRADA  
Fort Belvoir, Virginia**

**Contract No. DA-44-009-AMC-1246(X)**

**26 October 1966**

Prepared by: M. Gantsweg  
M. Gantsweg

Reviewed by: G. W. Olson  
G. W. Olson  
Project Manager

Approved by: P. D. Rodgers  
P. D. Rodgers  
Associate Lab Director

## TABLE OF CONTENTS

I	ABSTRACT
II	FUNCTIONAL DESCRIPTION
III	DESIGN CONSIDERATIONS
IVA	TRANSPONDER PERFORMANCE
IVB	TRANSPONDER PERFORMANCE, THE MATS AND THE SECOR DME SYSTEM
V	CONCLUSION - MODIFIED SPECIFICATION
VI	ADDITIONAL INFORMATION
	1. The MATS Transponder in the Present SECOR System
	2. The MATS Transponder with a Modified SECOR Ground Station
	3. MATS Transponder and the Phase Station
	4. Improvement of Transponder Phase Shift
	APPENDIX A - THE POST FILTER PROBLEM
	APPENDIX B - SYSTEM BANDWIDTH REQUIREMENTS
	APPENDIX C - NOISE BANDWIDTH CORRECTION FACTOR

SECTION 1

ABSTRACT

## 1. ABSTRACT

This report is submitted to the U. S. Army Engineer's Research and Development Laboratories, Fort Belvoir, Virginia, in response to Contract No. DA 44-009-AMC-1246(X), dated 25 June 1965. The report is divided into five (5) discrete sections, (1) a functional description of the transponder, (2) design considerations, (3) transponder performance, (4) conclusions, and (5) additional information.

The transponder is discussed on a functional basis with reference to its block diagram. The functional blocks are broken down on a module basis for convenience.

The design considerations are discussed with reference to each paragraph in the purchase specification. Where necessary, analytical support has been included.

Actual performance test data obtained from the breadboard transponder is discussed and compared to theoretical performance. The actual MATS performance is related to the Secor DME system and its range capabilities compared to that obtained using the purchase description performance specification.

In conclusion, a complete specification has been included which reflects the anticipated performance of the prototype units. This specification is supported by the design considerations discussed in this report and by the performance of the breadboard system.

As additional important information, the MATS transponder is discussed in relation to the present Secor system and a "modified" Secor system. The transponder and phase station compatibility requirements are noted. Areas of improvement are noted and related to the MATS future.

SECTION II  
FUNCTIONAL DESCRIPTION

## II. FUNCTIONAL DESCRIPTION OF TRANSPONDER

The MATS transponder utilizes a crystal-controlled double-conversion phase locked (correlation) receiver with a subcarrier phase-following loop around the complete transponder, for the purpose of phase stability and the realization of the required transponder sensitivity. Thus high sensitivity is realized in the presence of high modulation index subcarriers. Coherent AGC is employed in the receiver. The transmitter is crystal-controlled and phase-modulated, and employs transistors as active stages throughout, as does the transponder receiver. The data amplifier, which improves the transponder signal-to-noise performance by crystal filters, is a fully micro-electronic design, as is much of the transponder receiver circuitry. Cavity filters are employed to realize a high-quality, low-leakage diplexer. The power supply includes integral voltage regulators and dc-to-dc converters of the pulse width modulation type.

The transponder consists of six basic subchassis:

1. Diplexer/RF
2. IF Amplifier
3. Demodulator/Data Amplifier
4. Phase Modulator/Oscillator
5. Transmitter
6. Power Supply

A brief description of the circuit complement of each of these subchassis is given below, along with the functional description of each. Refer to Figure 1 for functional block diagram.

The Diplexer/RF chassis contains the Diplexing T, the preselector portion of the diplexer, a two-stage RF amplifier, another 2-pole preselector, a balanced mixer and a 2-pole L.O. filter.

A

10

9

8

7

**RF DIPLEXER**  
 BLOCK DIAGRAM D5506572  
 SCHEMATIC DIAGRAM D5506571

**IF AMPLIFIER**  
 BLOCK DIAGRAM F5506665  
 SCHEMATIC DIAGRAM H5506666

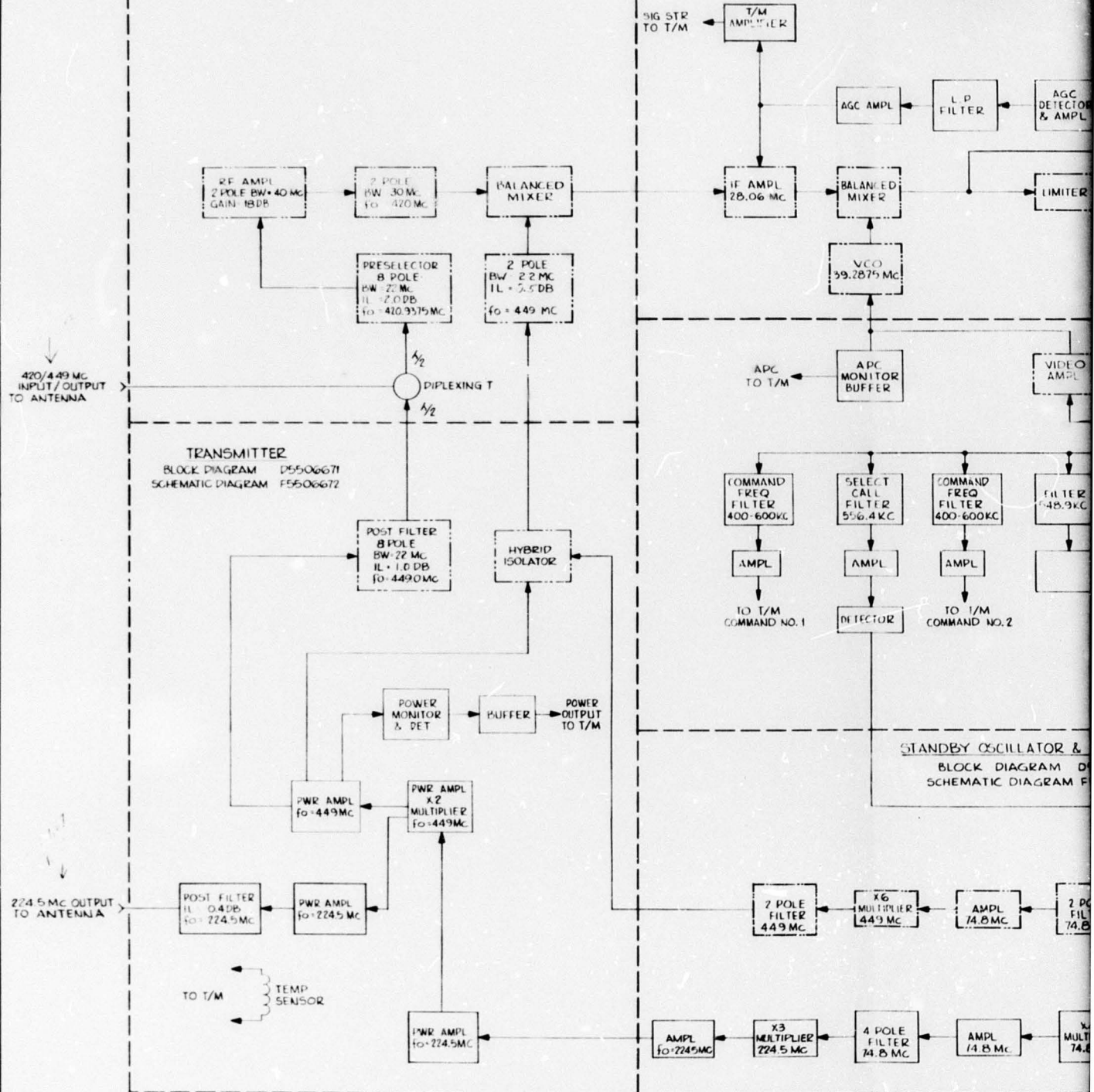

AMPLIFIER  
BLOCK DIAGRAM F550665  
SCHEMATIC DIAGRAM H550666

IF DEMODULATOR & DATA AMPLIFIER  
BLOCK DIAGRAM F550668  
SCHEMATIC DIAGRAM E550669

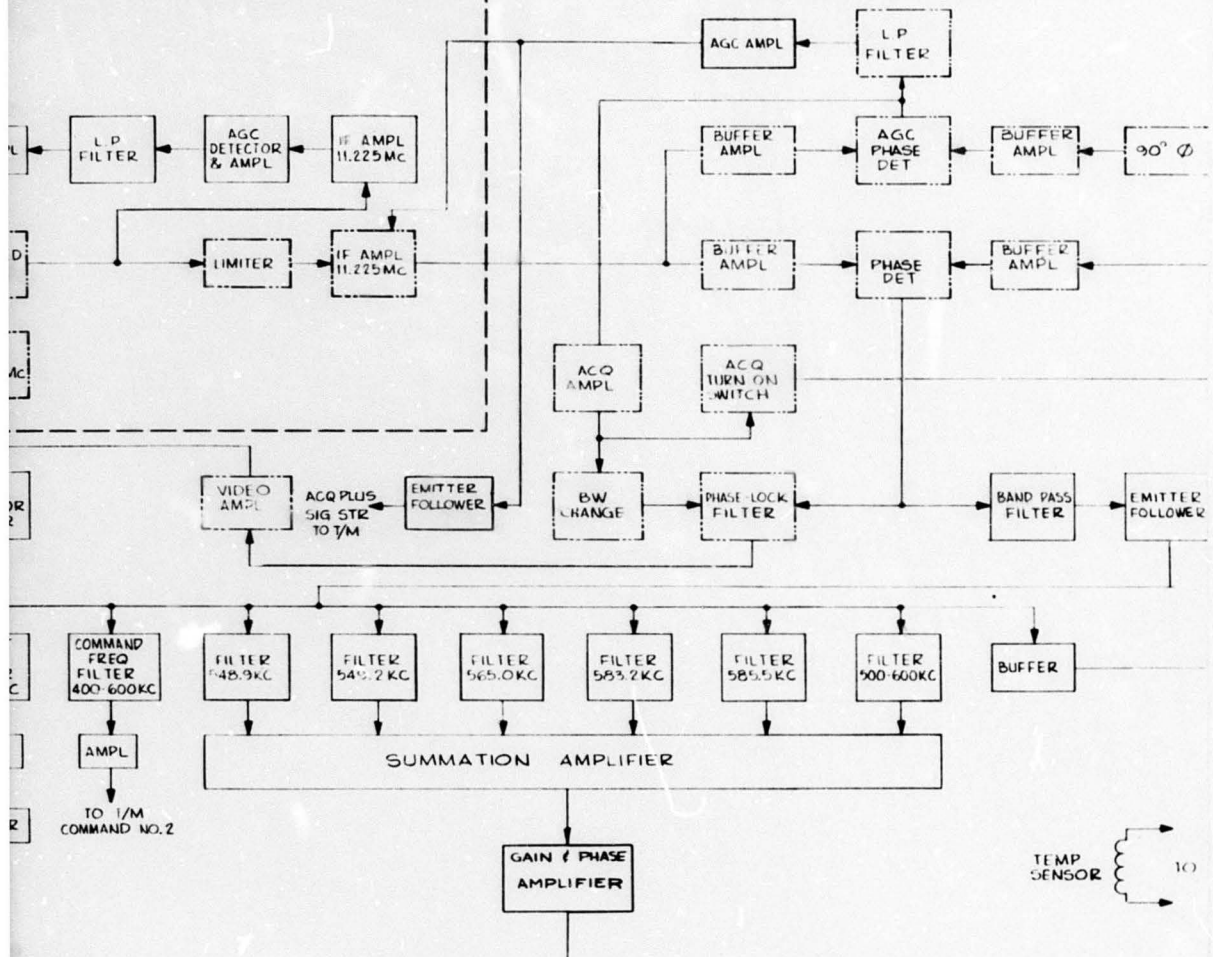

STANDBY OSCILLATOR & PHASE MODULATOR  
BLOCK DIAGRAM D550656B  
SCHEMATIC DIAGRAM F5506569

POWER

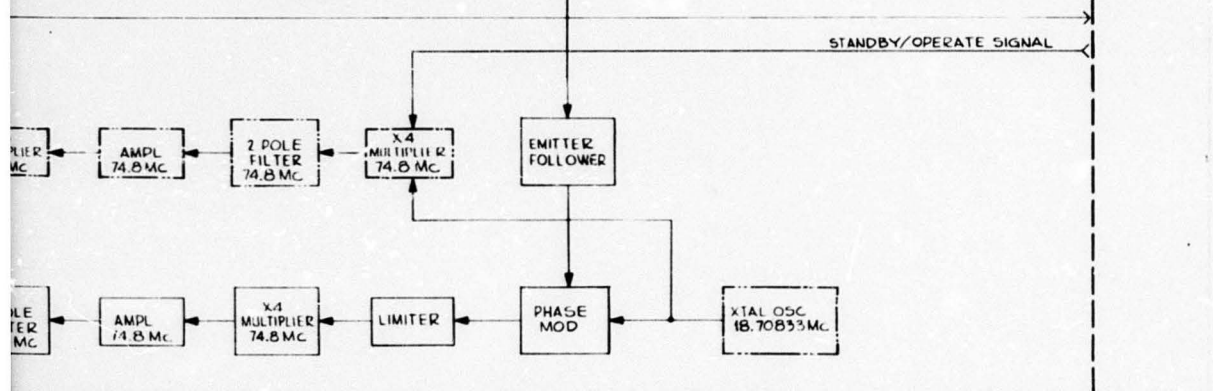

NOTE: UNLESS OTHERWISE SPECIFIED  
 1. THE AREAS INDICATED BY PHANTOM LINES  
 ARE THOSE FUNCTIONS WHICH ARE IN  
 OPERATION DURING THE STANDBY PHASE  
 OF THE MULTI-ALTITUDE TRANSPONDER.

ORIGINAL ISSUE		REVISIONS		
SYM	ZONE	DESCRIPTION	DATE	APPROVED
A				1000ZR

**OR & DATA AMPLIFIER**  
 AM F5506668  
 AGRAM F5506669

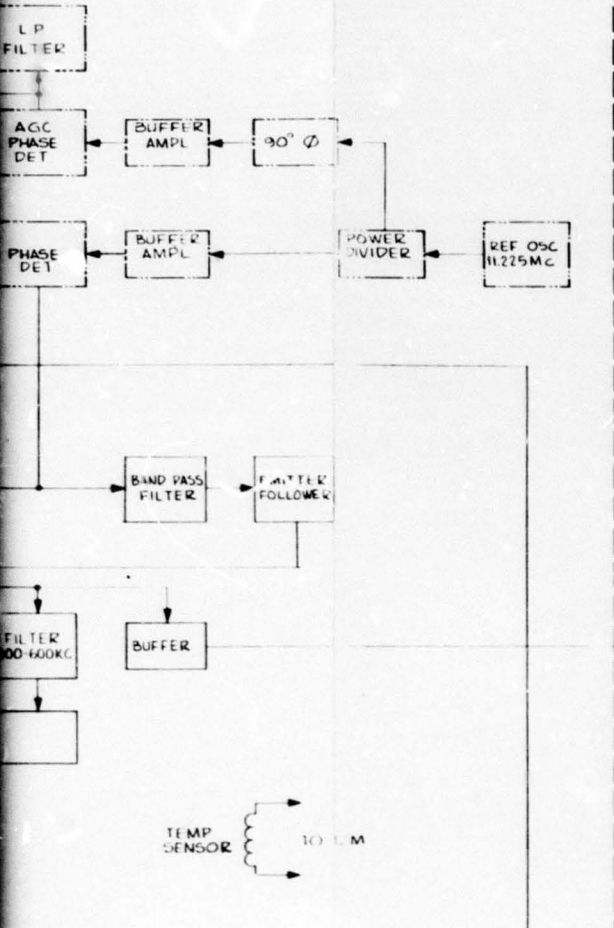

↑  
 SUBCARRIER  
 ↓  
 EXTERNAL  
 OUTPUT

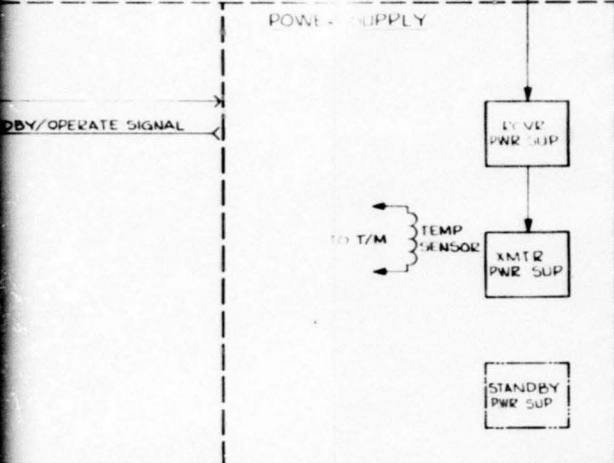

IN PART NO. COL. DENOTES VENDOR ITEM  
 SEE SOURCE CONTROL OR SPECIFICATION  
 CONTROL DRAWING

G6	G5	G4	G3	G2	G1	U	ITEM	CODE	QUANTITY	PART OR	DESCRIPTION OR
30	20	10	00	90	80	70	NO	IDENT	PER GROUP	IDENTIFYING NO	DESCRIPTION

MATERIAL		FINISH		APPLICATION	
Q	Q	Q	Q	Q	Q

UNLESS OTHERWISE SPECIFIED			
DIMENSIONS ARE IN INCHES AND INCLUDE CHEMICALLY APPLIED OR PLATED FINISHES			
TOLERANCES			
BASIC DIMENSION	DECIMALS	FRAC TIONS	
UNDER 6	± .02	± .005	± 1/64
6 TO 24 INCL	± .03	± .010	± 1/32
OVER 24	± .06	± .015	± 1/16
ANGLES ± 1/2°			
CONC. TOL. APPLY TO STOCK SIZES			
SHOP PRACTICE ESM ± .38 APPLIES			

APPROVALS		SIGNATURE & DATE	
CHECKED	MECH		
		J. SIMPSON	10/25/65
CODE IDENT NO		DRAWING NO	
90348		H 5506394	
SCALE		SHEET 1 OF 1	

A low level 420.9375 MHz signal (-45 to -115 dbm) is received by the transponder and fed into the Diplexing T and through an 8-pole 20 MHz bandwidth preselector to the RF amplifier. Simultaneously, a 449 MHz high level signal (+35 dbm) is being transmitted through the T to the receiver shared antenna. The 8-pole preselector guarantees that the level of the 449 MHz signal to the RF amplifier is less than -30 dbm, thereby negating problems which otherwise would have been encountered if the area of operation for the RF amplifier was nonlinear. The RF amplifier is a low noise wideband circuit which provides +17 db of gain to the 421 MHz signal and only +2 db to the undesirable 449 MHz signal. To further reduce undesirable effects from the 449 MHz signal, an additional 2-pole bandpass filter (30 MHz bandwidth) is used to pass 421 MHz and reject 449 MHz by 27 db. The output of this 2-pole filter is fed to the RF input side of a balanced hot-carrier diode mixer. The L.O. input to the mixer is obtained from the transmitter module. Since this mixer is used as the phase following subtractor to close the transponder phase following loop, the L.O. input is wideband and contains the spread spectrum signal. A 2-pole bandpass filter (30 MHz BW) is used to pass the wideband signal about 499 MHz while rejecting out-of-band frequency components sufficiently to provide a clean L.O. injection to the mixer. The mixer output is the product of the 449 MHz signal and the 421 MHz signal giving the sum and difference frequencies along with higher order products, each with their own modulation spectrums. The desired signal is the difference frequency (28.06 MHz) and the associated modulation spectrum. Note that the output modulation spectrum about 28.06 MHz is smaller than those at 421 MHz or 449 MHz due to phase subtraction of the spectral components by the mixer.

The IF amplifier module consists of four synchronously tuned 28.06 MHz IF amplifier stages, a second mixer, an amplitude limiter stage at 11.225 MHz, a single stage coherent AGC'd IF amplifier at 11.225 MHz, a noncoherent AGC loop, an AGC telemetry amplifier, and a voltage controlled oscillator (VCO).

The minimum 28.06 MHz IF input signal level is -110 dbm while the input noise level is -95 dbm. The quiescent gain of the IF is 69 db providing an input signal level to the second mixer of -42 dbm plus noise at -28 dbm in a 5 MHz bandwidth. Each stage of the IF amplifier has a nominal gain of approximately 16 db and a bandwidth of 14 MHz. It is reverse AGC'd by the noncoherent AGC loop to provide +20 to -50 db of automatic gain control in the "receive" and "transmit" mode.<sup>1</sup> Standby mode operation provides a fixed level gain with symmetric limiting in each amplifier stage.

The second mixer is an active double-balanced type which provides a +5 db power gain at 11.225 MHz and -20 db attenuation of the 39 MHz L.O. (-5 dbm input level), and 28.06 MHz IF. The 39.28 MHz VCO feeds this mixer. Its frequency control is derived from the carrier phase lock loop in the demodulator module.

The output of the second mixer is fed to the 11.225 MHz limiter stage and the noncoherent AGC input amplifier. The symmetric limiter prevents the stage output from providing greater than -3 dbm output independent of the stage signal or normal noise input level.

The limiter output is fed to a linear 11.225 MHz amplifier which provides 15 db of coherent AGC control. The AGC is of the forward type to ensure linear operation over the entire dynamic range of operation. The 11.225 MHz coherent signal output is a constant -6 dbm, independent of normal signal or noise input levels.

<sup>1</sup>"Standby" Mode - Ready to receive a coherent carrier

"Receive" Mode - Coherent carrier received and ready for commands

"Transmit" Mode - All circuitry operating

The noncoherent AGC circuitry consists of 2 stages of 11.225 MHz IF, providing 32 db of power gain and a bandwidth of 2.0 MHz. Its output is fed to a detector amplifier which provides a DC output voltage proportional to the input signal level into the receiver. The output voltage is used to control a current amplifier which provides reverse AGC control for the 28.06 MHz IF stages.

The Demodulator/Data Amplifier module contains (1) part of the phase lock loop consisting of a phase detector, reference oscillator, phase lock, a video amplifier, and associated buffer stages, (2) part of a correlation detector loop consisting of a phase detector, a 90° phase shifter, lowpass filter, coherent AGC amplifier, acquisition amplifier, and associated buffer stages, (3) the data amplifiers consisting of ranging and timing crystal filter networks, summation amplifiers, command and select call filters and amplifiers, a select call AM detector, and (4) a temperature sensor and telemetry amplifiers.

The 11.225 MHz signal from the IF module is power split between the correlation and phase lock loops. The phase and correlation detector reference signals are obtained from the 11.225 MHz reference oscillator with the latter a phase quadrature resultant from the 90° phase shifter. Under locked conditions, the output of the phase detector contains the demodulated subcarriers and a DC voltage corresponding to the frequency difference between the 11.225 MHz reference and the 11.225 MHz signal before lockup. The DC voltage is fed to the phase lock filter, which determines primarily the PLL<sup>2</sup> acquisition and signal to noise ratio performance, and a video amplifier which determines primarily the steady state phase error. The video amplifier output feeds the VCO located in the IF chassis, completing the PLL. The demodulated ranging subcarriers are fed to filter networks (3 db BW = 100 cps) for S/N ratio improvement. The output of each network is summed together, amplified and fed to the Phase

<sup>2</sup>PLL: Phase Lock Loop

Modulator/oscillator module. The command and select call subcarriers are fed to their respective crystal filters, again for the purpose of S/N improvement. The command outputs are amplified and fed to the transponder telemetry output connector. The select call output is amplified and detected by an AM diode detector and fed to the power supply module.

The correlation detector output is a DC voltage proportional to the received input signal. Its output is filtered, amplified and fed to the IF module for coherent AGC and to the power supply module to command the transponder from the "standby" to the "receive" mode.

The phase modulator/oscillator module provides a phase modulated transmitter driving signal and the receiver standby first local oscillator signal. The modulation is the series of ranging tones from the data amplifier. The RF signal is developed from a temperature compensated crystal oscillator.

The temperature compensated crystal oscillator supplies a one milliwatt signal at 18.7 MHz for both the transmitter multiplier chain and the receiver first local oscillator multiplier chain. The power split off to the transmit leg is phase modulated by the data summation amplifier output. This modulation signal is composed of up to six tones in the frequency range 400 to 600 KHz at levels of about 0.3 volts rms each. Peak modulation levels will deviate the carrier approximately 0.625 radians. The phase modulator output is amplitude limited in the following integrated circuit stage by cutoff and saturation limiting. Limiting is used to remove incidental AM from the phase modulated signal. The spectrum is frequency multiplied by four to approximately 75 MHz and is then amplified to 50 milliwatts. A 4-pole filter follows the amplifier to suppress unwanted harmonics of the 18.7 MHz oscillator frequency by at least 60 db. The filter has a 3 db bandwidth of 3 MHz. A frequency tripler follows the filter to raise the spectrum to 224.5 MHz. The following amplifier provides sufficient power gain to supply 20 milliwatts of drive to the transmitter module.

The other oscillator output at 18.7 MHz is multiplied by four to 75 MHz. It is then filtered in a 2-pole, 6 MHz wide filter to suppress unwanted oscillator frequency harmonics. The following amplifier raises the level of the 75 MHz to about 15 milliwatts to drive the step recovery diode multiplier to supply a 1 milliwatt output at 449 MHz. The diode output is filtered by a 2-pole 8 MHz wide filter to suppress unwanted 75 MHz harmonics. The filtered 1 milliwatt output at 449 MHz is used as the receiver standby first local oscillator.

The transmitter module contains a 224 MHz medium power amplifier, X2 multiplier, 224 MHz high power amplifier, 449 MHz high power amplifier, power monitor, hybrid isolator, a 449 MHz post filter, and a 224.5 MHz post filter.

The transmitter module receives an input signal at 224.5 MHz at a power level of 20 milliwatts. This signal is amplified to 1 watt, fed to the 224.5 MHz final amplifier, whose output of 5 watts is fed to a 2-pole bandpass post filter providing approximately 4 watts output into a 50 ohm load. The 3 db bandwidth of the 224.5 MHz output is 12 MHz. The 224.5 MHz 1 watt signal is also fed to a frequency doubler whose 449 MHz output is 1.5 watts. This output feeds the 449 MHz final stage which provides 6.5 watts to the 8-pole post filter. The post filter 2.5 db insertion loss reduces the transponder output power to 3.5 watts into a 50 ohm load. The power monitor is an AM detector using an RF diode into a buffer amplifier whose output is fed to the telemetry connector. The hybrid is used to isolate the standby L.O. circuitry from the operate L.O. circuitry.

The Power Supply module provides transponder power for "standby", "receive" and "transmit" modes. Incorporated in the module are time delay and logic circuits which control standby and transmit power. The outputs are regulated against input and load changes. They are isolated from input power leads and the module chassis. Momentary short circuit and reverse polarity input protection is provided.

One of the prime considerations for the technical approach to the MATS Power Supply was the conservation of battery power. In order to achieve this, the unit was designed with high efficiency as one of the important aspects. For this reason, pulse width modulators are used to convert the available fluctuating input voltage into a highly regulated DC voltage which powers a DC to DC converter. The PWM utilizes the transistor in the switching mode only. During the on-cycle of the switch, energy flows through an inductor into the output capacitor. Simultaneously, energy is stored in the inductor. During the off-cycle, the inductor discharges its stored energy into the output capacitor. By varying the duty cycle, regulation is achieved at a high efficiency level. The DC to DC converter (often called a square-wave inverter) provides three distinct advantages:

- The converter allows step-up or step-down to any desired output voltage.
- The output wave shape is a square-wave which after rectification requires very little filtering.
- The transistors operate in a switching mode only and therefore cause the lowest losses, resulting in a high efficient conversion.

Sensing of the output voltage and error signal amplification is accomplished by transistor differential amplifiers which are known for their good temperature stability. The differential amplifier controls a magnetic amplifier which is powered from the converter transformer. The output of the magnetic amplifier controls the duty cycle of the pulse width modulator. Sensing could have been accomplished by the magnetic amplifier only; however, then, the problem of temperature stability would have become critical.

Only those outputs that are the most critical as far as regulation are concerned are being sensed. The other outputs are taken, after rectification, directly from the converter transformer. As the input to the DC to DC converter is regulated, the output of the DC to DC converter is also regulated and is subject to transformer regulation and coupling only.

SECTION III  
DESIGN CONSIDERATIONS

### III. DESIGN CONSIDERATIONS

#### Description

The MATS transponder was designed to be a compact, lightweight, efficient transponder for use in Satellite configurations. The transponder consists of a receiver and transmitter for accepting ranging, timing and command information from a station located on a ground complex and retransmitting the ranging and timing information on two offset carriers back to the ground complex. In addition, certain telemetry circuits are provided within the transponder in order that conditions concerning the transponder may be telemetered back to the ground station by telemetry systems external to the transponder.

The transponder's overall dimensions are  $9 \frac{1}{2}$ " x  $4 \frac{1}{4}$ " x  $6 \frac{1}{2}$ " or 235 cubic inches (Refer to Figure 2) and its total weight is less than 12 lbs. In standby it requires 1.3 watts. In the transmit mode it delivers a nominal 3.5 watts at 224.5 MHz and a nominal 3.5 watts at 449 MHz, the latter under a duplexed conditions with its receiver, while using 44 watts of primary power for an overall efficiency of 16 percent.

Modular construction has been employed for ease of fabrication and maintenance. Figure 2A shows the Phase Modulator/Oscillator Subchassis. One view shows the cover of the 74.8 MHz filter removed. Figure 2B is the I-F amplifier subchassis shown before and after the printed circuit board is installed in the subchassis housing.

The following discussion of design considerations is referenced directly to the contract purchase description by paragraph number.

#### 3.1.1 Composite Signal

The composite signal from the ground complex consists of a carrier whose nominal frequency is 420.9375 MHz phase modulated by any combination of fixed frequency subcarriers as follows:

<u>Subcarrier Frequency</u>	<u>Description</u>
a. 585.533 KHz	Subcarrier referenced to ground station complex and used to measure range.
b. 583.246 KHz	Same as a.

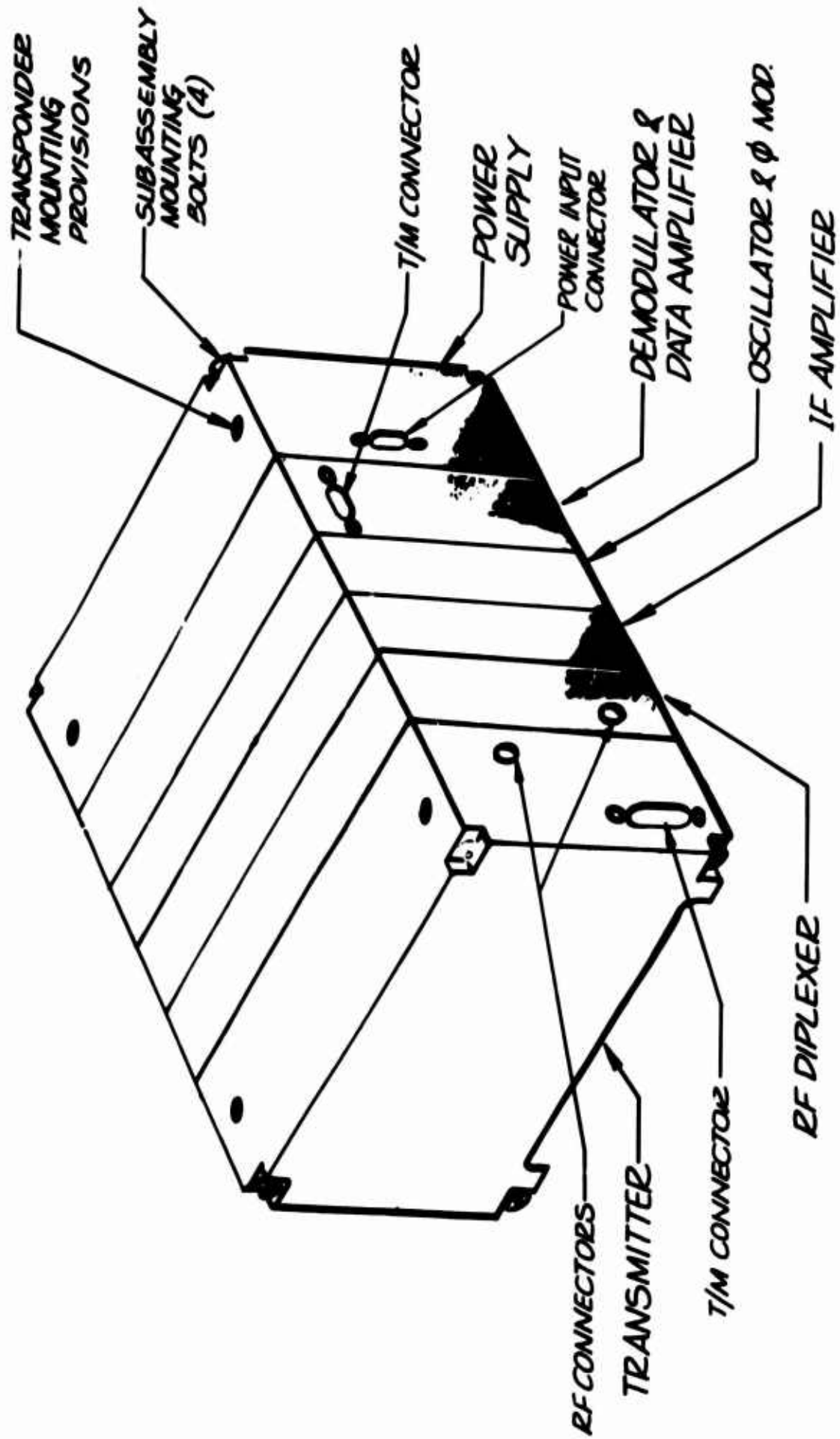

Figure 2

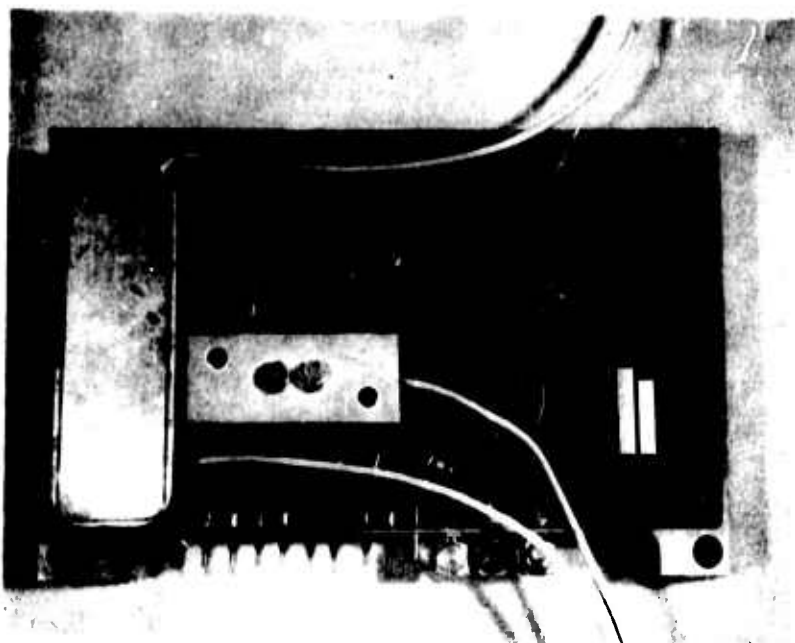
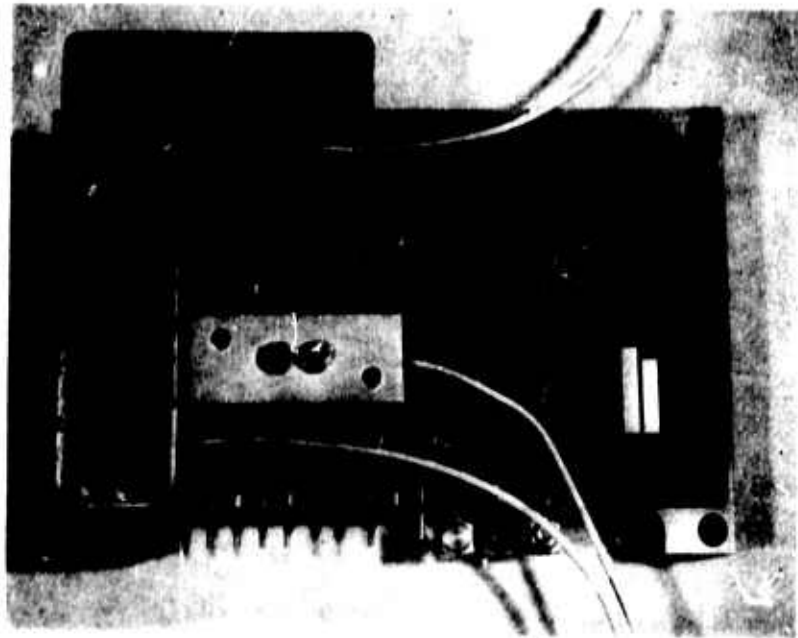
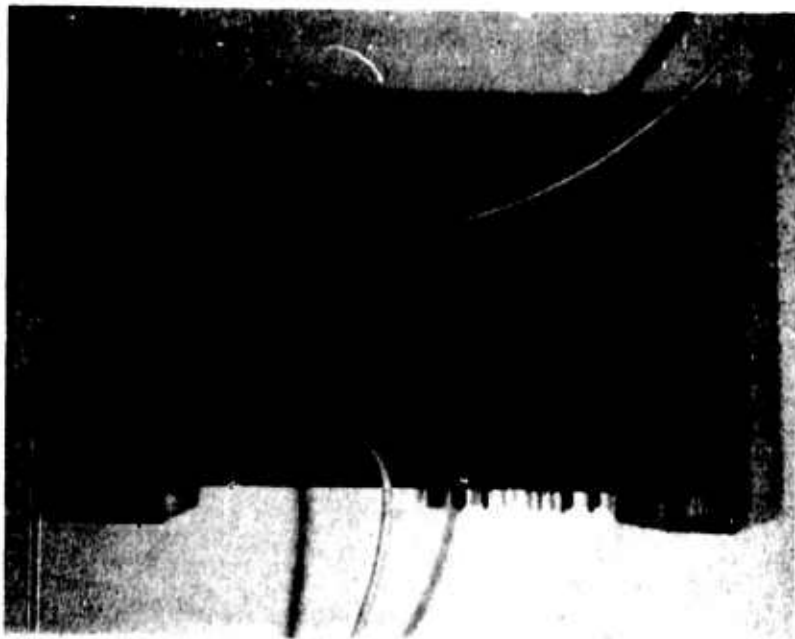
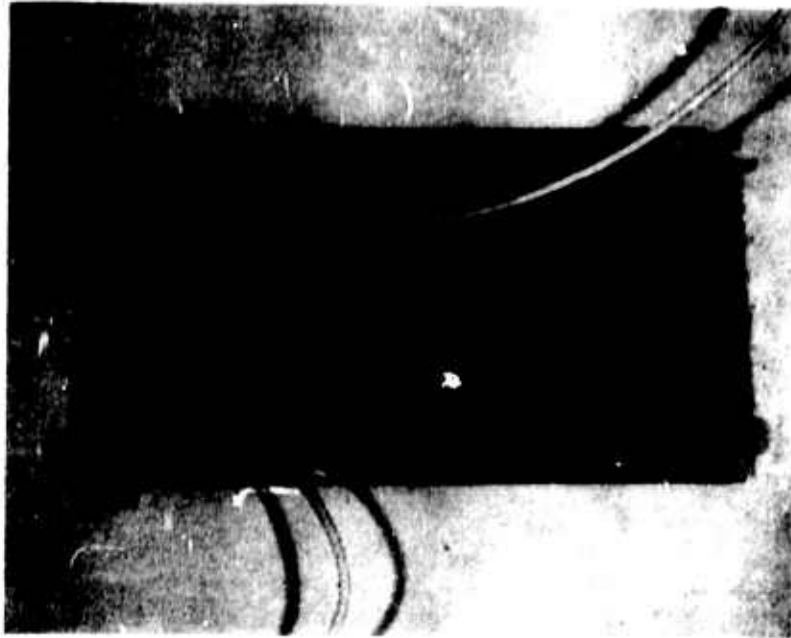

Figure 2A. Phase Modulator/Oscillator Subchassis



**Figure 2B. I-F Amplifier Subchassis**

**3-2B**

<u>Subcarrier Frequency</u>	<u>Description</u>
c. 549.223 KHz	Same as a.
d. 548.937 KHz	Same as a.
e. 565.000 KHz	Subcarrier used to establish system timing.
f. Subcarrier in the range of 500-600 KHz	Subcarrier used as a Satellite ranging function
g. Subcarrier in the range of 500-600 Khz	Subcarrier used as a Satellite Command function
h. Subcarrier in the range of 500-600 KHz	Same as g.
i. Subcarrier in the range of 400.00 KHz to 600.00 KHz	Subcarrier known as "Select-call" and used to command the transponder from receive to a transmit condition.

The modulation index of each individual ranging or timing subcarrier can be as high as 2.5 radian and will normally exist within the range of 0.5 to 2.5 radians. The modulation index of the select call and command subcarriers should be in the range of 0.25 to 0.5 radians. The composite index can be any index that might result from any combination of subcarriers modulated within this range.

Of the above received subcarriers, only those shown in a. through f. are modulated on the transmitter carrier for retransmission to the ground complex.

Of particular interest is the different modulation index requirement for the select call and command subcarriers. The 0.25 to .5 index is necessary since these particular subcarriers are not retransmitted by the transponder,

thereby requiring their composite indexes not to exceed 1 radian. Linearity is thus preserved through the receiver phase detector.

A note on the retransmission of the command and select call subcarriers.

Since  $\frac{M'_I}{M_I} = 30$  for a phase following feedback ratio = 30

where  $M'_I$  = Maximum modulation index of select call or command subcarriers

$$M'_I = 0.5 \text{ radians}$$

$M_I$  = Minimum modulation index of a range or timing subcarrier within the transponder phase following feedback loop

$$M_I = 0.5/30 = .0166 \text{ radians}$$

then the baseband crystal filters used for ranging and timing subcarriers are required to reject the command and select call frequencies by 300:1 to ensure that a maximum index of say .05 radians is modulated on the transmitter carrier. Since, for stability reasons, a single-pole crystal filter is required for each feedback subcarrier, and a 3 db bandwidth of 100 cps is reasonably specified, then, due to a PFFB<sup>3</sup> ratio of 30:1, a resultant closed loop bandwidth of 3 KHz and 6 db/octave filter rejection rate, one would expect no greater than a 23 db or 14:1 rejection of a subcarrier frequency 30 KHz distant.

Thus, in order to ensure that the command and select call subcarriers are minimally modulated on the transmitter carrier: (1) their subcarrier frequencies should be chosen as far from the feedback subcarriers (a-f) as possible, (2) the modulation index used for their transmission should be kept as small as possible and (3) the modulation index of subcarriers a-f should be maximized. Thus

<sup>3</sup>PFFB: Phase Following Feedback

$$\frac{M_1'}{M_1} = \frac{.25}{2.5/30} = 3$$

Filter rejection ratio - 14:1

then the ratio of modulation index of each desired subcarrier to that of the select call or command subcarrier is 14/3 or 4.7:1.

### 3.1.2 Transmitter

The nominal frequency of the two (2) offset transmitter frequencies is 449.000 MHz and 224.500 MHz. The transmitter section of the transponder is designed to provide either 1.5, 3.5 or 4.5\*(selectable) watts of output power at the transmitter antenna terminal for the two (2) transmission frequencies of the transmitter.

The 449 MHz and 224.5 MHz frequencies are easily derived from a common TCXO at 18.7083 MHz. A not so easy task is providing the 4.5 watts output power at the 449 MHz transmitter antenna terminal. This problem area exists because of the high insertion loss exhibited by the post filter and associated diplexer loss. The high insertion loss is due to (1) the large number of poles required by the filter plus (2) the wide bandwidth required to pass the information in association with the small frequency separation between the transmitter and receiver frequencies. The choice of 8 poles as the number required by the post filter is derived in Appendix A. The primary design criteria being based upon the amount of noise generated by the transmitter in the receiver acceptance frequency band. Appendix B verifies the wide bandwidths required by the post and preselector filter to pass the modulation. Using a cavity type filter, constructed within the size limitation of the package, the

\*Refer to text for spec modification.

calculated theoretical insertion loss for an 8 pole bandpass filter with the desired Chebychef response is

$$\rho = n \left( 20 \log \frac{Q_u + Q_L}{Q_u} \right) \quad (1)$$

where

$\rho$  = filter insertion loss (db)

$Q_u$  = Unloaded cavity Q

$Q_L$  = Loaded cavity Q

n = number of filter poles

now

$$Q_u = \frac{Q_L Q'_u}{Q_L + Q'_u} \quad (2)$$

where

$Q_L$  = tuning capacitor Q

$Q_L = 1,000$  (Refer to Fig. 3)

and  $Q'_u = 60 \times s \times \sqrt{f_0} \quad (3)$

where

S = cavity diameter (inches)

$f_0$  = center frequency of resonance (MH)

$$Q'_u = 60 \times 1 \times \sqrt{449}$$

$$Q'_u = 1270$$



then

$$Q_u = \frac{1270 (1000)}{1000 \cdot 1270} = 560$$
$$Q_L = \frac{f_o}{BW_{3db}} \quad (4)$$

where

$BW_{3db}$  = 3db bandwidth of each cavity section under loaded conditions.

$$Q_L \sim \frac{449}{28} = 16$$

thus

$$\rho = 8 (20 \log \frac{560 \cdot 16}{560})$$

$$\rho = 8 (.244)$$

$$\rho = 1.95 \text{ db}$$

Measured values of the post filter insertion loss are 2.0 db  $\pm$  0.1 db. An additional 0.5 db loss occurs when this filter is diplexed with the receiver pre-selector. Figure 4 is a plot of the dissipation in a transmission cavity (db) vs. the ratio of  $Q_L/Q_u$ . For the case above,  $Q_L/Q_u$  equals .0285. The  $Q'_u$  obtained for our cavity is proportional to S, that is, the size of each cavity. Thus practical limitations necessitate a cavity dimension limit. As is, the post filter used requires a 90° bend to restrict its volume to the confines of the chassis structure. But the limiting factor on  $Q_u$  is not the cavity Q, since a variable tuning element within each cavity structure is required to properly retune the filter when diplexed with the preselector. The Q of this element is also important. Refer to Figure 3. The post filter used in the MATS transponder thus represents the best possible effort consistent with the state-of-the-art and the restrictions of the spec, in the development of a low loss element.

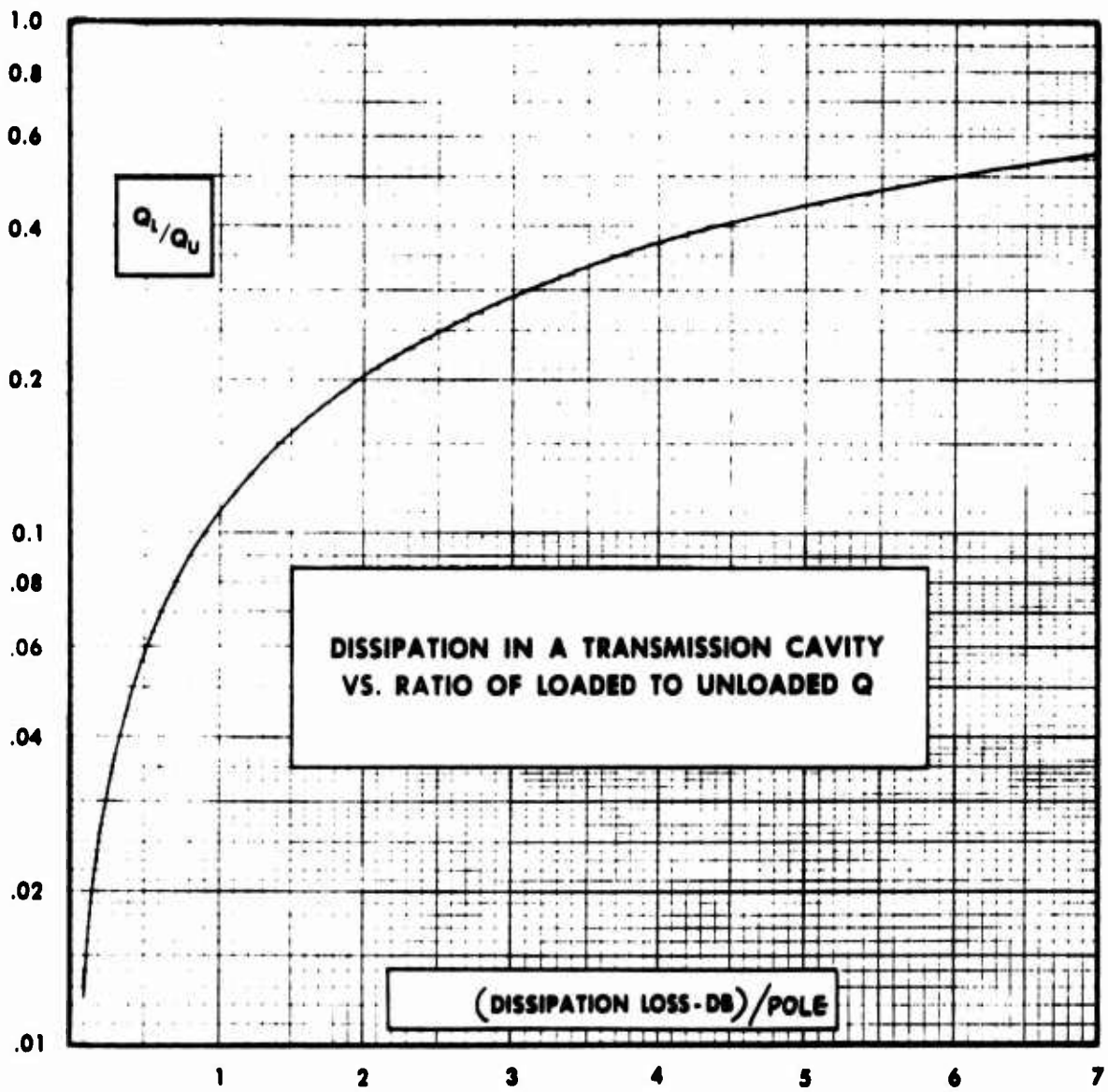

Figure 4

One might speculate that a lower post filter/diplexer loss could be obtained by reducing the bandwidth requirement of the post filter to say 1/2.

From Appendix A we have the required post filter rejection of 421 mc = 66 db; therefore, minimum number of poles required at 1/2 the present bandwidth = 5.

$$Q_u = 560$$

$$Q_L = \frac{f_o}{BW_{3db}} = \frac{449}{14} = 32$$

$$Q_L/Q_u = \frac{32}{560} = .0572$$

Dissipation loss/pole = 0.5 db

$$\rho_1 = 5 (0.5) = 2.5 \text{ db}$$

Thus  $\rho_1 > \rho$  by approximately 0.5 db. The diplexing loss would be the same 0.5 db in both cases.

It becomes obvious that one method which could be used to reduce the post filter/diplexer loss is to further separate the transmitter and receiver carrier frequencies. If the separation were doubled with all other parameters held constant, we have

$$Q_u = 560,$$

$$Q_L = 16$$

$n = 4$  for the same rejection at 421 MHz as previously noted.

Dissipation loss/pole = 0.244 db

$$\rho_2 = 4 (.244) = 1 \text{ db}$$

thus, instead of the present 3.5 watts, one could expect 4.5 watts at the antenna terminals with no increase in primary power to the transponder.

The transmitter output power selection is accomplished by two simple steps, (1) a resistor value change (located external to the power supply module) to adjust the 28 volt power supply voltage, (2) slight retuning of the transmitter module. Since the power supply efficiency was designed to be fairly independent of the load, the transponder primary input power reduces in almost direct proportion to a corresponding reduction in output power.

### 3.1.3 Phase Shift

The SECOR System is a phase measuring system and as such, the transponder must impart the smallest possible phase shift to the incoming ranging subcarriers over wide ranges of signal input and conditions of environment as referenced in paragraph 3.4.3 of the purchase description.

In distance measuring systems, where range information is derived by comparing the phase of a modulating signal (or signals) of the transmitted carrier with that of the detected signal(s) of the received carrier, phase stability is of primary importance. The method used to meet the phase stability requirements for the MATS transponder is called Phase Following Feedback.

Although we can find the literature covering the subject of PFFB, sometimes called "Frequency compressive feedback," or "frequency following demodulation," it may be helpful to analytically review the technique and in so doing, point out basic design areas of concern.

A simplified block diagram of the PFFB loop used in the MATS transponder is shown in Figure 5. Important operational parameters are shown. An assumption to be made for the following expressions is that the bandpass elements used in the transponder have a flat amplitude response and linear

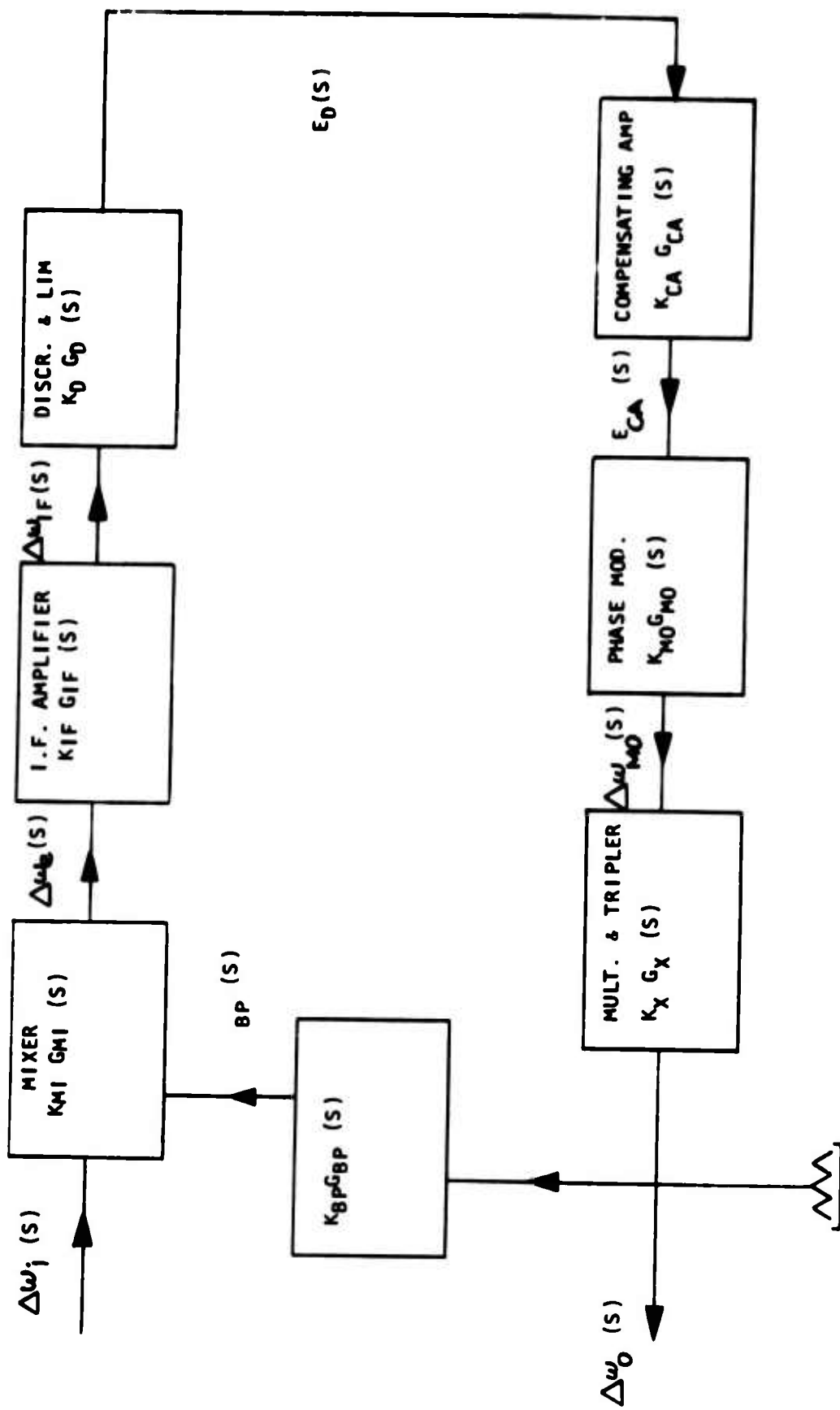

Figure 5. BLOCK DIAGRAM OF TRANSPONDER FOR TRANSFER FUNCTION ANALYSIS

phase shift in the frequency region which includes all significant sidebands so that a linear analysis does apply. This requirement is not overly stringent since these characteristics are essential for good inherent phase stability and low modulation distortion.

The following equations are derived from the block diagram:

$$\frac{\Delta \omega_o(s)}{\Delta \omega_i(s)} = \frac{K_{FO} G_{FO}(s)}{K_T G_T(s) + 1} \quad (1)$$

$$K_{FO} G_{FO} = K_{MI} K_{IF} K_D K_{CA} K_{MO} K_X G_{MI} G_{IF} G_D G_{CA} G_{MO} G_X$$

$$\frac{\Delta \omega_o(s)}{\Delta \omega_i(s)} \quad \text{closed loop transfer function}$$

$$\frac{\Delta \omega_o(s)}{\Delta \omega_e(s)} \quad \text{Transfer function of forward loop} \quad (2)$$

$$K_T G_T(s) = K_{FO} G_{FO}(s) \cdot K_{BP} G_{BP}(s)$$

$$\frac{\Delta \omega_{BP}(s)}{\Delta \omega_e(s)} \quad \text{Transfer function of total loop} \quad (3)$$

where:

$\Delta \omega_i(s)$  Laplace Transform of the frequency deviation of the input carrier frequency

$\Delta \omega_{BP}(s)$  Laplace Transform of the frequency deviation of the output carrier frequency, after passing through B.P. filter

- $\Delta \omega_e(s)$  - Laplace Transform of the frequency deviation of the input intermediate frequency
- $K_{MI}$  = Frequency independent factor of the transfer function (in this case,  $K_{MI} = 1$ )
- $G_{MI}(s)$  - Frequency dependent factor of the transfer function of the modulation frequencies in the mixer.
- $K_{IF}$  - Frequency independent factor of the transfer function = 1
- $G_{IF}(s)$  - Frequency dependent factor of the transfer function of the modulation frequencies in the I. F. amplifier
- $K_D$  - Gain of the phase detector
- $G_D(s)$  - Frequency dependent factor acting upon the modulation frequencies in the phase detector
- $G_{CA}(s)$  - Frequency dependent factors acting upon the modulation frequencies in the compensating amplifier.
- $K_{MO}$  - Gain of the phase modulator in radians phase shift per volt of modulation signal
- $G_{MO}(s)$  - Frequency dependent factor acting upon the modulation frequencies in the phase modulator
- $K_x$  = Frequency multiplication factor
- $G_X(s)$  = Frequency dependent factor acting upon the modulation frequencies in the multipliers and transmitter.
- $K_{BP}$  = Frequency independent factor of the transfer function = 1
- $G_{BP}(s)$  - Frequency dependent factor acting upon the modulation frequencies in the Band Pass filter.
- $K_{CA}$  = Gain of the compensating amplifier.

Let total loop gain at any frequency  $j\omega$  be

$$K_{\mu\phi} G_T(j\omega) = K_{\mu\phi} e^{j(\alpha_\mu + \alpha_\phi)} \quad (4)$$

and  $K_{FC} G_{FC}(j\omega) = K_{\mu} e^{j\alpha_\mu} \quad (5)$

where

$$K_{\mu\phi} = \text{system loop gain} = P K_D K_{CA} K_{MO} K_X$$

$P$  = input modulation angular frequency

$K$  = forward loop system gain

Therefore equation (1) reduces to

$$\frac{\Delta \omega_o(j)}{\Delta \omega_i(j)} = \frac{K_{\mu\phi} e^{j(\alpha_\mu + \alpha_\phi)}}{K_{\mu} e^{j\alpha_\mu} + 1} \quad (6)$$

We can equate the closed loop transfer function  $\frac{\Delta \omega_o(j)}{\Delta \omega_i(j)}$  to a modulation index change since

$$m = \frac{\Delta \omega}{\omega_m}$$

then

$$\frac{\Delta \omega_o(j)}{\Delta \omega_i(j)} = \frac{m_o}{m_i} e^{j\theta} \quad (7)$$

where

$m_o$  = transmitter output modulation index

$m_i$  = transmitter input modulation index

$$\text{Letting } \tan \alpha_0 = \frac{K_{\mu\beta} \sin(\alpha_\mu + \alpha_\beta)}{K_{\mu\beta} \cos(\alpha_\mu + \alpha_\beta) - 1}$$

$$\text{and } R = \sqrt{K_{\mu\beta}^2 - 2K_{\mu\beta} \cos(\alpha_\mu + \alpha_\beta) + 1}$$

$$\text{then } \frac{m_0}{m_i} = \frac{K_{\mu\beta} e^{j\alpha}}{R e^{j\alpha}}$$

$$\frac{m_0}{m_i} = \frac{K_{\mu\beta}}{\sqrt{1 - 2K_{\mu\beta} \cos(\alpha_\mu + \alpha_\beta) + K_{\mu\beta}^2}} \quad (8)$$

and

$$\alpha_0 = \alpha_\mu - \tan^{-1} \frac{K_{\mu\beta} \sin(\alpha_\mu + \alpha_\beta)}{K_{\mu\beta} \cos(\alpha_\mu + \alpha_\beta) - 1} \quad (9)$$

since  $K_{BP} = 1$  then  $K_\mu = K_{\mu\beta}$  (our case). Of particular interest is to note that in equation (8) as  $K_{\mu\beta}$ , the system loop gain, becomes large (i.e.  $K_{\mu\beta} \gg 1$ ) then  $m_0 \rightarrow m_i$ , that is, the retransmitted modulation index approaches that received by the transponder.

For example taking MATS transponder parameters,  $K_{\mu\beta} = 30$ , and  $(\alpha_\mu + \alpha_\beta)$  a small angle,  $K_\mu = K_{\mu\beta}$ , then

$$\frac{m_0}{m_i} \approx \frac{K_{\mu\beta}}{K_{\mu\beta} + 1} = \frac{30}{31}$$

or

$$m_0 \approx m_i$$

The output modulation index  $m_0$  is very closely equal to  $m_i$ , the input modulation index. Also noting equation (9) and allowing the practical case (our's) of

$$\alpha_\beta = \text{very small}$$

$$\alpha_\mu \gg \alpha_\beta$$

$$K_{\mu\beta} \gg 1$$

then 
$$\alpha_o = \tan^{-1} \frac{K_{u\beta} \sin(\alpha_u + \alpha_\beta)}{K_{u\beta} \cos(\alpha_u + \alpha_\beta) - 1}$$

can be written

$$\begin{aligned} \alpha_o &= \alpha_u - \tan^{-1} \frac{K_{u\beta} \sin \alpha_u}{K_{u\beta} \cos \alpha_u - 1} \\ &= \alpha_u - \tan^{-1} \left( \frac{\sin \alpha_u}{\cos \alpha_u} + \frac{K_{u\beta} \sin \alpha_u}{-1} \right) \\ &= \alpha_u - \tan^{-1} (\tan \alpha_u - K_{u\beta} \sin \alpha_u) \\ &= \alpha_u - \alpha_u + \tan^{-1} K_{u\beta} \sin \alpha_u \\ \alpha_o &= \tan^{-1} K_{u\beta} \sin \alpha_u \end{aligned} \quad (11)$$

As  $K_{u\beta} \uparrow$ . Then  $\alpha_o \rightarrow 0$

Since we are interested in  $\Delta\alpha_o$  with conditions such as temperature and dynamic range which in themselves create loop phase shifts, then we calculate

$\frac{d\alpha_o}{d\alpha_i}$ ,  $\frac{d\alpha_o}{d\alpha_\beta}$ . These quantities representing the rate of change

of the output modulation signal phase shift with changes in the forward loop and feedback loop phase shifts. In addition, we are also interested in

$\frac{d\alpha_o}{dK_{u\beta}}$  which represents the rate of change of the output phase shift with

open loop gain.

From equation (7)

$$\frac{d\alpha_0}{d\alpha_\mu} = \frac{1 - K_{\mu\beta} \cos(\alpha_\mu + \alpha_\beta)}{K_{\mu\beta}^2 - 2K_{\mu\beta} \cos(\alpha_\mu + \alpha_\beta) + 1} \quad (12)$$

$$\frac{d\alpha_0}{d\alpha_\beta} = \frac{K_{\mu\beta} \cos(\alpha_\mu + \alpha_\beta) - K_{\mu\beta}^2}{K_{\mu\beta}^2 - 2K_{\mu\beta} \cos(\alpha_\mu + \alpha_\beta) + 1} \quad (13)$$

Figures 6 and 7 give plots of these quantities with  $K_{\mu\beta}$  as parameter. Notice that in the limit for  $(\alpha_\mu + \alpha_\beta) = n\pi$  where  $n = 0, 2, 4, \text{etc.}$  and  $K_{\mu\beta} \gg 1$  we have

$$\frac{d\alpha_0}{d\alpha_\mu} \rightarrow -\frac{1}{K_{\mu\beta}} \quad \text{and} \quad \frac{d\alpha_0}{d\alpha_\beta} = -1$$

thus, a change in the forward path phase is reduced at the transponder output by the factor  $\frac{1}{K_{\mu\beta}}$ , but a change of phase in the feedback path is not reduced by PFFB. For the MATS transponder, we have

$$K_{\mu\beta} = 30$$

$$\Delta\alpha_\mu = 60^\circ \quad (\text{Worse case temperature change})$$

$$\Delta\alpha_\beta < 0.1^\circ$$

FIGURE 6  
 $\frac{\partial \alpha_0}{\partial \alpha} = \frac{1 - K_{\mu\beta} \cos(\alpha + \beta)}{K^2_{\mu\beta} - 2K_{\mu\beta} \cos(\alpha + \beta) + 1}$  VS  $(\alpha + \beta)$  WITH  $K_{\mu\beta}$  AS A PARAMETER

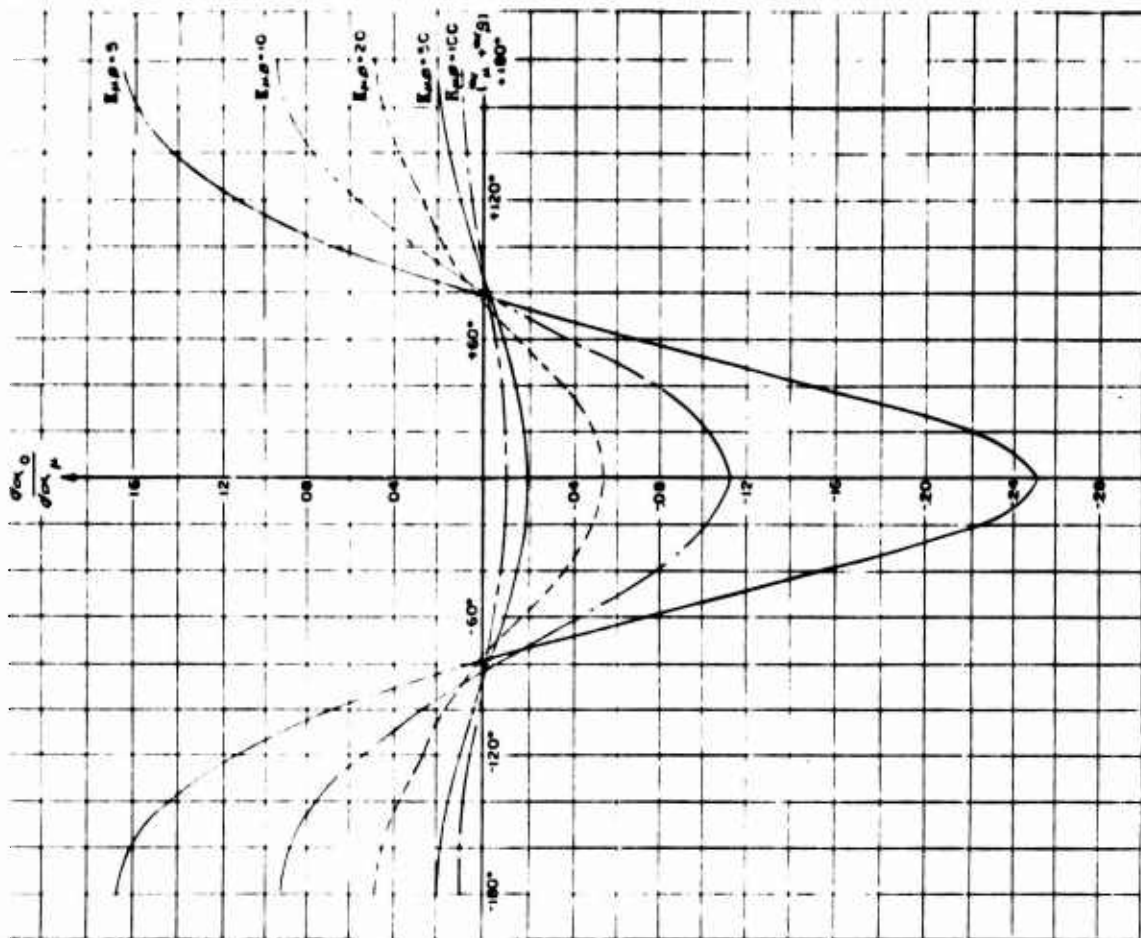
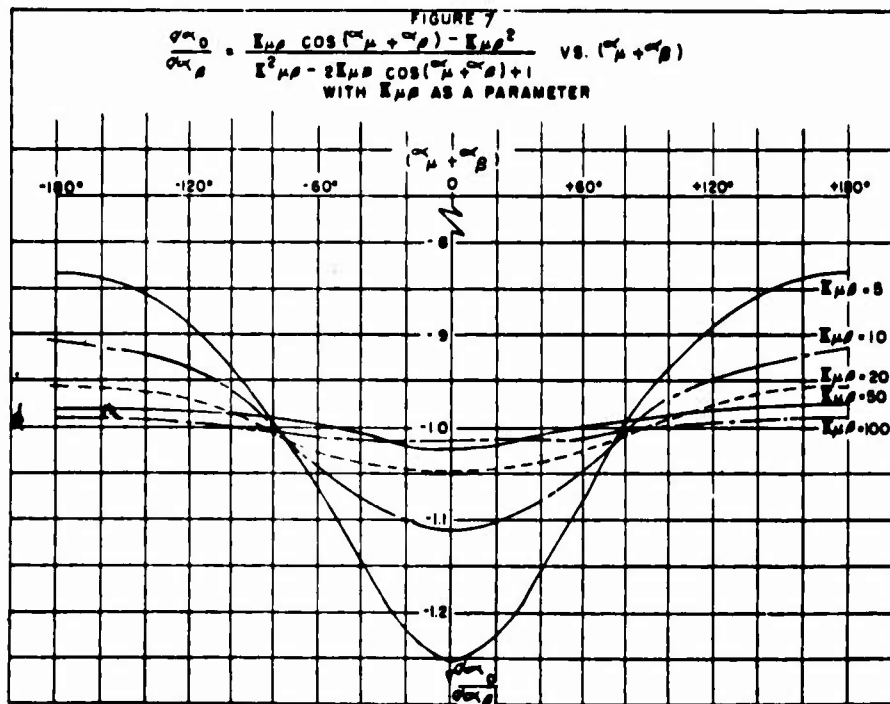
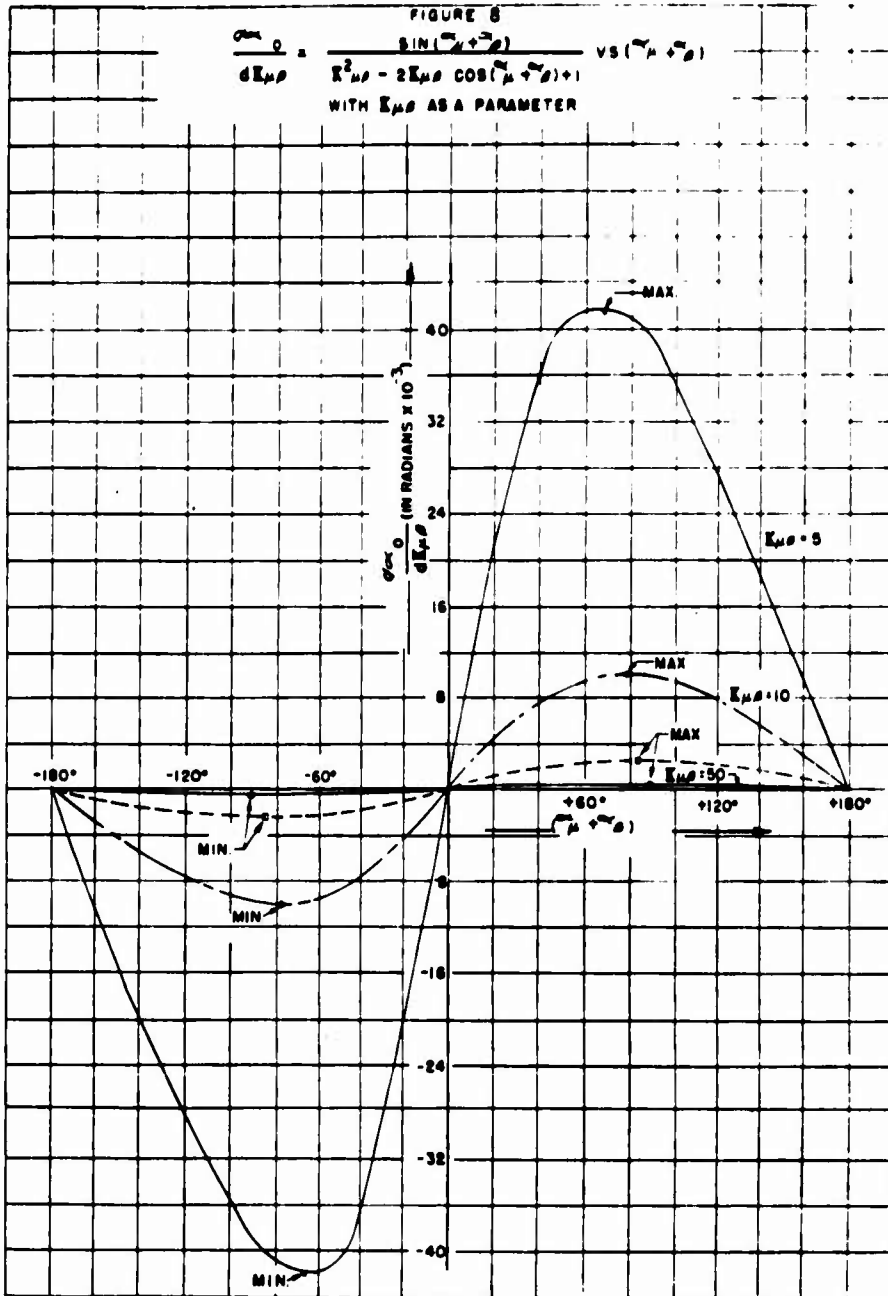

FIGURE 7  
 $\frac{\partial \alpha_0}{\partial \alpha} = \frac{K_{\mu\beta} \cos(\alpha + \beta) - K_{\mu\beta}^2}{K^2_{\mu\beta} - 2K_{\mu\beta} \cos(\alpha + \beta) + 1}$  VS  $(\alpha + \beta)$   
 WITH  $K_{\mu\beta}$  AS A PARAMETER





$$\frac{d\alpha_o}{d\alpha_u} \approx \frac{1}{K_{u\beta}}$$

$$\Delta\alpha_o = \frac{\Delta\alpha_u}{K_{u\beta}} = \frac{60^\circ}{30} = 2^\circ$$

$$\frac{d\alpha_o}{d\alpha_\beta} \approx -1$$

$$\Delta\alpha_o = -\Delta\alpha_\beta = -0.1^\circ$$

It becomes evident from the above, that a good PFFB transponder should exhibit a negligible change in phase in the feedback path since PFFB at its best, will not correct this phase change. Indeed, the MATS transponder feedback path contains a negligible number of wideband components in this path, all of which exhibit  $< 0.1^\circ$  phase change over all environmental and operating conditions.

One should also note that, assuming the above condition is satisfied  $\Delta\alpha_\beta \ll \Delta\alpha_u$ , the closed loop phase change is proportional to the forward loop phase change. Thus,  $\Delta\alpha_u$  should be kept as small as possible.

From equation (7) we have

$$\frac{d\alpha_o}{dK_{u\beta}} = \frac{\sin(\alpha_u + \alpha_\beta)}{K_{u\beta}^2 - 2K_{u\beta} \cos(\alpha_u + \alpha_\beta) + 1} \quad (14)$$

Figure 8 shows a plot of  $\frac{d\alpha_o}{dK_{u\beta}}$  vs. parameter  $(\alpha_u + \alpha_\beta)$  the total phase shift of the loop.

These plots are used in the choice of the open loop gain  $K_{u\beta}$ , and the phase  $\alpha_u + \alpha_\beta$ . Since it is desirable to minimize the phase variation with variations in circuit parameters, the following conclusions are reached: (1) The loop gain  $K_{u\beta}$  should be maintained as high as feasible. System parameters dictate the maximum practical gain that can be achieved with reasonable hardware.

(2) Since  $\frac{d\alpha_0}{d\alpha_u}$  and  $\frac{d\alpha_0}{dK_{u\beta}}$  vs.  $(\alpha_u + \alpha_\beta)$  are approximately  $90^\circ$  out of phase,

examination of the actual expected variations of  $\alpha_u$  and  $K_{u\beta}$  is needed to choose the value of  $(\alpha_u + \alpha_\beta)$  at which the sum of both effects is minimized.

Another factor to be considered, however, is to provide a closed loop system with adequate stability margins. This dictates the maximum allowable loop gain  $K_{u\beta}$  and also the selection of  $\alpha_u + \alpha_\beta$  near to  $2\pi n$  where  $n = 0, 1, 2, 3, \dots$ . In general, a value near zero for  $\alpha_u + \alpha_\beta$  best satisfies both requirements.<sup>4</sup>

In the MATS transponder, the stability of the loop dictates  $(\alpha_u + \alpha_\beta) = 2\pi n$  where  $n = 0, 1, 2, 3, \dots$ .

since

$$\alpha_u \gg \alpha_\beta$$

then

$$\alpha_u = 2\pi n$$

and

$$\frac{d\alpha_0}{dK_{u\beta}} \cong 0$$

that is, the closed loop output phase is minimally affected by changes in the open loop system gain.

Also, one should note that although  $K_{u\beta}$  would normally be chosen as large as possible to minimize  $\alpha_0$ , another primary factor, receiver sensitivity, dictates a maximum  $K_{u\beta}$  since practical filter bandwidths at the MATS sub-carrier frequencies are limited.

MATS crystal filters necessitate the use of type DD cuts which exhibit high level spurious at 60% of their center frequencies. Consideration of all of the above factors yielded  $K_{u\beta}$  maximum of 30.

Note: The mixer is a phase subtractor and, therefore, represents  $\pi$  radians of the total  $(\alpha_u + \alpha_\beta)$ .  $\therefore (\alpha_u + \alpha_\beta) = \pi n$ , where  $n = 1, 3, 5, \dots$  for MATS.

#### 3.1.4 Solid State Components

The transponder is designed using silicon solid state components exclusively. This choice assured reliable operation over the required ambient temperature range ( $-4^{\circ}\text{F}$  to  $+160^{\circ}\text{F}$ ) and a sufficient margin to allow extended temperatures to be used if deemed justified at some future date.

#### 3.2 Materials

All materials used in the transponder are of such substance as not to deteriorate in the environment (vacuum, radiation, vibration and heat) to which the transponder will normally be subjected and defined in the purchase specifications. Any questionable materials were tested within the expected environment prior to inclusion within the final design.

##### 3.3.1 General

The transponder is designed for a useful life of at least one year's normal operation. The transponder is to be used in satellite configurations in orbits up to 2500 nautical miles at inclinations from 0 to 90 degrees.

The transponder is designed to operate in a "standby", "receive" or "transmit" condition. In the "standby" condition (minimum power mode), only those circuits necessary to place the transponder in a "receive" condition upon receipt of a coherent carrier are operative. In the "receive" mode those circuits required to provide access to the select call and other normal command signals, are engaged. Upon receipt of a select call subcarrier the "transmit" mode is initiated. In the "transmit" condition, all circuits are energized and the transponder is capable of performing in a manner called out in modified specification, Section 5.

The one year operation is satisfied by using worst case circuit design techniques. This assures us that if all components of a particular network

were to attain the worst possible parameter variation as defined by their individual specs, then the circuit would still perform its function satisfactorily.

In addition, the networks in themselves were conservatively designed, when possible, to allow beyond spec limits to occur (except in a few isolated cases) and still operate satisfactorily. High reliability components were used whenever possible.

During "standby" operation, a minimal number of circuits are operative consistent with the necessity of commanding the transponder into a receive mode. A coherent carrier commands the transponder into the receive mode which can be used for commands to telemetry or the select call operation. A select call command initiates full power to all transponder circuits.

The select call frequency is easily changed to any subcarrier frequency within the 400 to 600 KHz range (and beyond if necessary).

### 3.3.2 Weight

The weight of the transponder, including interconnecting cables, connectors, and hardware, is less than 12 pounds.

The transponder weight is kept to a minimum by (1) the lack of a main frame assembly, (2) the scalloping the modules to remove that metal not necessary for structural strength and (3) the minimum use of covers between modules resulting from the use of the backs of each as the RF shield for those adjacent.

Magnesium was considered, but it was too expensive and difficult to work.

### 3.3.3 Size and Shape

The overall volume of the transponder, including mounting brackets, connectors and hardware, is 235 cubic inches for all power levels. The transponder is housed in one (1) regular figured rectangular package. The outside

dimensions, excluding mounting brackets, mating connectors and other hardware are 4 1/4" x 6 1/2" x 8 1/2".

A pictorial of the complete package is shown in Figure 9. All available space within the allowable maximum dimensions was used to the fullest extent possible due to the high volume of circuitry found necessary to satisfy all the transponder functional requirements.

This new package was developed to satisfy the MATS configuration, and in addition, (1) to allow easy component accessibility by both engineering and technical personnel during both operating and nonoperating conditions and (2) easy module interchangeability.

Note that the transponder can be unfolded like a book. (Refer to Figure), allowing almost complete access to all circuitry without removal of a single wire. Thus the transponder can be in operating condition when completely exposed. Alignment of the overall transponder is thus simplified and tailor values can easily replace variables so that no adjustments are provided, nor needed, once the alignment is complete (except those necessary for retuning the transmitter to different output power levels). Inter - module wiring (except coax) is hard wired point-to-point to eliminate connector unreliability.

#### 3.3.4 Dissimilar Metals

Dissimilar metals are not used in intimate contact unless protected against electrolytic corrosion. Dissimilar metal combinations and comparable metal coupling is as defined in MIL-STD-33586.

The chassis (modules) are aluminum and circuitry boards copper. Both are gold-plated. All screws are stainless steel.

#### 3.3.5 Connectors

The use of connectors is minimized to the highest degree practical. Where connectors are required, they are keyed or positioned so that mating

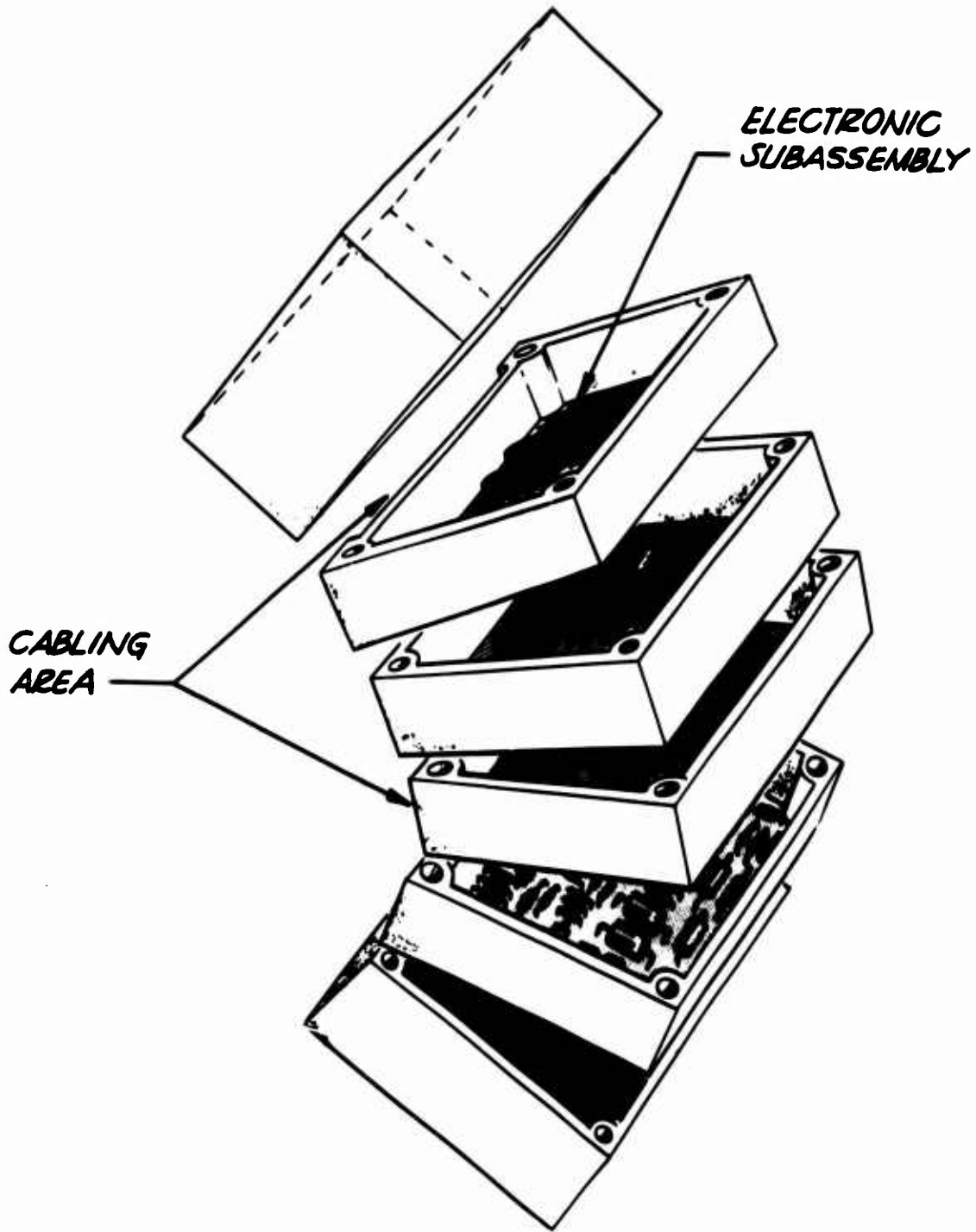

Figure 9

errors cannot be made. All connectors, once mated, are capable of being locked in place either by screw or other positive technique.

The transponder input/output connectors are (1) 2-telemetry multipin-keyed and screw lock types, (2) 1-power supply primary source connector-keyed and screw lock type, (3) 2-RF connectors single conductor positive lock types. All RF interconnections between modules use single conductor positive lock types.

### 3.3.6 Environment

#### 3.3.6.1 Thermal Vacuum

The transponder performs within the limits called out in paragraph 2.4 in thermal environments from minus 4 degrees F to plus 160 degrees F in vacuums of at least  $1 \times 10^{-5}$  mm of mercury. In addition, the transponder is capable of being stored in a vacuum of at least  $1 \times 10^{-5}$  mm of mercury at a temperature of  $-30^{\circ}\text{F}$  without damage to the transponder. Once removed, the transponder is capable of performing within the limits called out in paragraph 3.4.

The use of components capable of withstanding the thermal vacuum requirements is essential. All active components (i.e., transistors, integrated circuits), are capable at least  $-55^{\circ}\text{C}$  to  $+125^{\circ}\text{C}$  operating temperatures and minimum storage temperatures equal to or exceeding this range. For example, the 2N918 transistor and the  $\mu\text{A}702\text{A}$  integrated circuit are used extensively throughout the transponder. Refer to Table 1.

TABLE 1

	<u>2N918</u>	$\mu$ <u>A702A</u>
Max Storage Temperature	$-65^{\circ}\text{C}$ to $+300^{\circ}\text{C}$	$-65^{\circ}\text{C}$ to $+150^{\circ}\text{C}$
Maximum Operating Temperature	$-55^{\circ}\text{C}$ to $+200^{\circ}\text{C}$	$-55^{\circ}\text{C}$ to $+125^{\circ}\text{C}$

All passive components, resistors, capacitors, diodes, etc. are chosen, such that the normal operating thermal environment is conservative compared to the component ratings. All diodes are silicon, capacitors are either mica DM's, ceramic CK's or tantalitic SCM's, and resistors 1/4 watt-carbon film conservatively derated to less than 25% of maximum ratings.

### 3.3.6.2 Vibration

The transponder performs within the limits called out in paragraph 3.4 after being subjected to the following types and levels of vibration.

#### a. Sinusoidal Vibration (all major perpendicular axes)

<u>Frequency (cps)</u>	<u>Applied Vibration Level (zero to peak acceleration)</u>
5 - 14	0.5 in. DA
14 - 40	±5.0 g
40 - 50	±7.5 g
50 - 70	±30 g
70 - 2000	±22.0 g
2000 - 3000	±20.0 g

#### b. Random Vibration (all major perpendicular axes)

<u>Frequency (cps)</u>	<u>Applied Vibration Level (g<sup>2</sup>/cps)</u>
5 - 14	0.07 g <sup>2</sup> /cps
15 - 50	0.10 g <sup>2</sup> /cps
50 - 200	0.40 g <sup>2</sup> /cps
200 - 2000	0.20 g <sup>2</sup> /cps

#### 3.3.6.3 Shock

The transponder performs within the limits called out in paragraph 3.4 after being subjected to three half-sine wave shock impulses of 0.5 milliseconds duration at a level of 200 gs in each major perpendicular axis.

#### 3.3.6.4 Acceleration

The transponder performs within the limits called out in paragraph 3.4 after being subjected to sustained acceleration forces of at least 22 g for periods of at least 15 minutes in all major perpendicular axes.

To meet the vibration, shock, and acceleration requirements of this design, the following areas of the transponder have received special consideration:

- All internal cabling and wiring have been spot-bonded wherever possible to prevent excessive movement.
- All circuit board components have been conformally coated to the boards to eliminate movement and dampen vibration. Also, components that are exceptionally susceptible to damage have been bonded to the cases or circuit boards when practical.
- All filters have been filled with foam potting to reduce excessive movement and dampen vibration and they are mounted rigidly to the chassis.
- All circuit boards have been designed with the components, terminals and board representing a solid, non-flexing piece of hardware.
- The individual system chassis have been designed with rigid outside frames and solid center webbs to provide maximum strength at the component mounting locations.

- All of the individual system chassis are held together at each corner with adequate hardware to form a solid assembly.

Precision machined module surfaces insure minimum movement between individual module mounting surfaces.

### 3.3.7 Primary Power Requirements

The transponder performs within the limits called out in paragraph 3.4 when subjected to input voltage variations from 11.5 to 17.5 VDC. The input power requirements of the transponder shall not exceed those listed below, for the mode shown, with 17.5 volts DC applied at its primary power input.

Standby Mode	1.0 watts maximum
1.5 watt mode	17.5 watts maximum
3.5 watt mode	32.0 watts maximum
4.5 watt mode	39 watts maximum

#### MODIFIED TO (See Text)

Standby Mode	1.3 watts maximum
1.5 watt mode	25.0 watts maximum
2.5 watt mode	37.5 watts maximum
3.5 watt mode	46.0 watts maximum

As previously noted in Section 3.1.2, analysis of the post filter problem gave some insight into the problems of providing a 4.5 watt output mode. Part of this problem relates to restricted input power requirements listed above. Certainly, the insertion loss of a diplexer could conceivably be overcome by providing a correspondingly higher diplexer input. But to provide this higher final amplifier output requires additional primary input power, or an increase in the overall power efficiency of the transponder to negate the use of more primary power. The primary factors affecting the amount of primary power

used (during transmit) by the transponder are (1) the required output power, (2) the transmitter efficiency, primarily the high power stages, and (3) the power supply (DC to DC converter) efficiency.

The original required output power for the 4.5 watt mode was 4.5 watts at 449 MHz, and 4.5 watts at 224.5 MHz. Since the diplexer insertion loss is 2.5 db and the 224.5 MHz post filter insertion loss is 0.5 db, then the required output power from the 449 MHz final amplifier is  $1.8 \times 4.5 \text{ watts} = 8.1 \text{ watts}$ , and correspondingly, 5.05 watts from the 224.5 MHz final amplifier. The 449 MHz amplifier is best designed about class B or C operation to ensure optimum efficiency.

The collector circuit efficiency,  $\eta$ , is defined as the ratio of the a-c power delivered to the real load,  $R_L$ , divided by the d-c input power. When an ideal unilateral device is operated class B or class C,  $\eta$  will be greater than 78 percent. However, in a practical situation, collector-circuit efficiency will be either artificially high or much lower.

The principal causes of difficulty in obtaining ideal class B operation in a common-emitter circuit are excess emitter lead inductance,  $L_e$ , and internal capacitance,  $C_{cb}$ , between the collector and base terminals that shunt the active region of the transistor. The extra capacitance and its associated time constant with the resistances it drives produces a base drive that tends to keep the transistor ON when the external drive is moving it toward cutoff.  $L_e$  also tends to keep emitter current flowing, rather than allowing the emitter to be sharply cut off. The result of these effects is to produce a larger conduction angle and lower efficiency. With careful design, reasonable approximations to class B waveforms can be achieved with efficiencies of 50 to 70 percent.

The transducer gain provides an effective measure of circuit performance. Transducer gain is defined as the actual power output to the real load divided by the power available from the source. When this quantity is large compared to 1, the collector circuit

efficiency will be a meaningful quantity. When transducer gain drops significantly, appreciable power flow from input to output through passive elements may be occurring and the collector circuit efficiency then will be an artificial measure of circuit performance. This is obvious when it is realized that a transducer gain of 1 can be achieved with a passive matching network requiring no d-c input power. The normal definition of  $\eta$  would make it infinite for this case. For low-gain transistors, efficiency would better be defined as transistor efficiency.

$$\eta_{\text{transistor}} = \frac{P_{AC \text{ OUT}}}{P_{AC \text{ IN}} + P_{DC \text{ IN}}} \times 100\%$$

Figure 10 contains a curve showing the RF power output vs. RF power input at 400 MHz for the 3TE 440 transistor. This device was found to provide the most gain of any device presently available for the required power output at 449 MHz. Other transistors investigated were 2N4040 and RCA 2N3375. For the typical collector of circuit efficiency of 65 percent published in the 3TE440 spec (slightly optimistic for our case at 449 MHz), we have

$$P_{DC \text{ IN}}^{\text{FINAL}} = \left[ \frac{P_{AC \text{ OUT}}}{\eta_{\text{TRANS}}} - P_{AC \text{ IN}} \right]$$

$$P_{AC \text{ OUT}} = 8.1 \text{ WATTS}$$

$$\eta_{\text{TRANS.}} = 0.65 \text{ OR } 65\%$$

$$P_{AC \text{ IN}} = 2.8 \text{ WATTS}$$

$$\therefore P_{DC \text{ IN}}^{\text{FINAL}} = \left[ \frac{8.1}{0.65} - 2.8 \right] = 9.7 \text{ WATTS}$$

Repeating the above for the 2.8 watt driver 3TE 450. Refer to Figure 11 for 3TE450 curve.

$$P_{DC IN} = \left[ \frac{2.8}{\eta_{DOUBLER}} - 0.7 \right] = 4.9 \text{ WATTS}$$

1ST DRIVER  
DOUBLER

$$P_{DC IN} = \left[ \frac{0.7}{0.65} \right] \approx 1.1 \text{ WATTS}$$

SEC. DRIVER  
AT 20.45 MH

$$P_{DC} = \left[ \frac{5.35}{0.65} \right] = 7.7 \text{ WATTS}$$

20.45 MHz

$$P_{DC} = \frac{1}{0.65} = 1.5 \text{ WATTS}$$

20.45 MHz  
DOUBLER

3TE 440

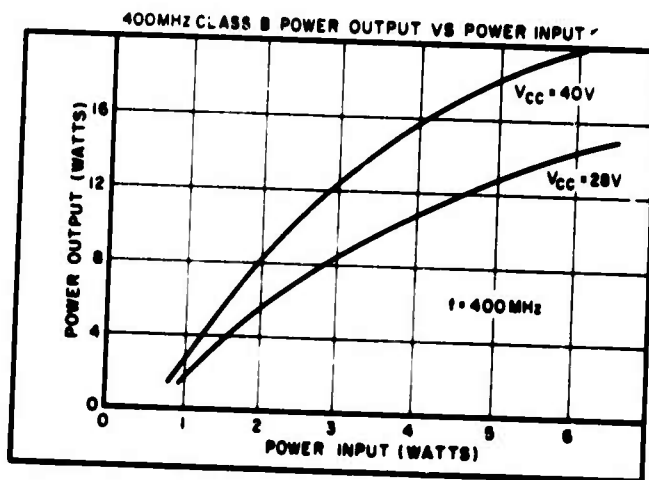
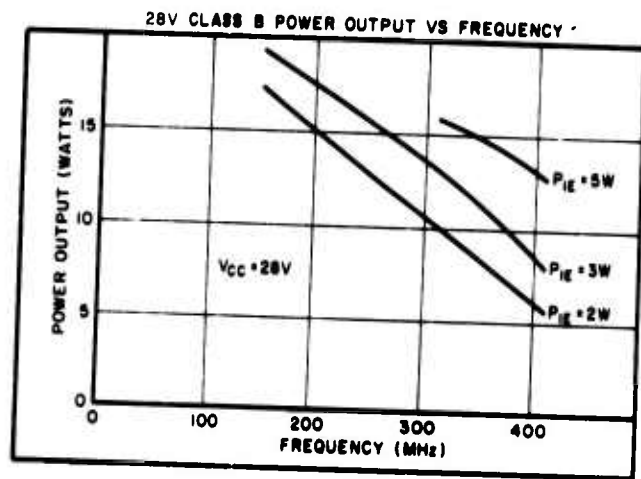
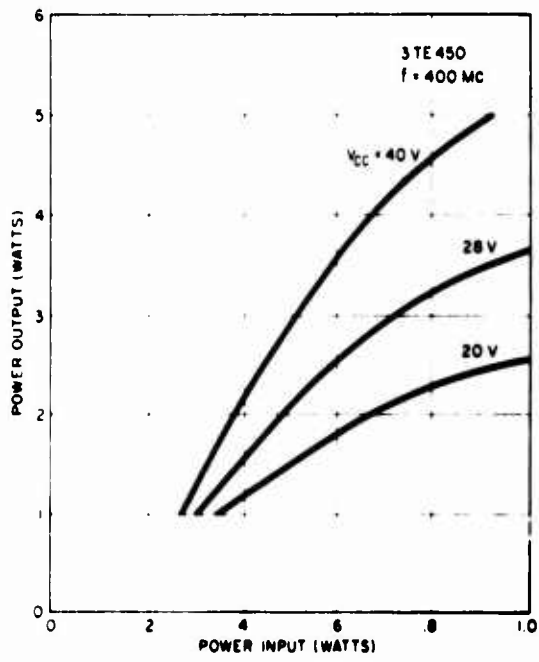

Figure 10

3TE 450



TYPICAL 400 Mc POWER OUTPUT  
vs POWER INPUT

Figure 11

Now

$$P_{DC IN \text{ TOTAL}} = P_{DC IN \text{ 449 FINAL}} + P_{DC IN \text{ 449 1ST DRIVER DOUBLER}} + P_{DC IN \text{ 224.5 2ND DRIVER}} + P_{DC IN \text{ 224.5 FINAL}} + P_{DC IN \text{ 224.5 DRIVER}} + [P_{DC IN}^*]$$

$$P_{DC IN}^* = \text{input power to operate all other transponder circuits} = 4 \text{ WATTS}$$

$$\therefore P_{DC IN \text{ TOTAL}} = 9.7 + 4.9 + 1.1 + 7.7 + 1.5 + 4$$

$$P_{DC IN \text{ TOTAL}} = 29.2 \text{ WATTS}$$

Since the maximum primary power allowed in the unmodified purchase spec is 39 watts, then the transponder power supply efficiency would have to be

$$\eta_{\text{POWER SUPPLY}} = \frac{29.2}{39} \times 100\% = 75\%$$

Notice that in the above calculations, near optimum conditions were assumed (1) nearly theoretical efficiencies, (2) no allowances for temperature effects, (3) the use of the same driver for 449 MHz and 224.5 MHz finals, (4) perfect VSWR matching (i.e., VSWR = 1). Thus, even with the above effects not taken into consideration, an overall DC to DC converter efficiency of 75% minimum would be required in order to meet the power input requirement. Can it be done? Bids were requested of a number of power supply manufacturers with Table II showing the two bids which came closest to meeting desired specifications.

All other manufacturers either refused the bid or were too far from requirements to be considered.

TABLE 2

	<u>Gulton Industries</u>	<u>ITT IPD</u>	<u>Result</u>
Operate Mode	70%	75%	71%
Standby Mode	55%	60%	60%
28 VDC Ripple	38 mv	10 mv	10 mv

The purchase order was let to ITT IPD with resultant performance shown in the last column. This efficiency exceeds comparable power supplies used on other programs. The major factor limiting the increase in power supply efficiency is the wide primary voltage variation of 11.5 to 17.5 volts and the high degree of voltage regulation required by the circuitry for the transponder.

Having assured ones self that indeed, the RF power output and DC power input requirements are inconsistent with state-of-the-art devices and techniques, what should be reasonably expect for RF output power, allowing 39 watts primary input power assuming production repeatability and environmental extremes -  $-4^{\circ}\text{F}$  to  $+160^{\circ}\text{F}$ :

$\eta$  power supply = 70% minimum

$\eta$  449 final = 50% minimum

$\eta$  224.5 final = 50% minimum

$\eta$  doubler = 40% minimum

$\eta$  224.5 driver = 50% minimum

$\eta$  224.5 driver = 50% minimum

$$P_{ac} = \eta_{p.s.} \times \text{Primary} = .7 \times 39$$

Available

$$P_{ac} = 27.3 \text{ watts}$$

Available

Assuming that 6.3 watts at 449 MHz and 3.9 watts at 224.5 MHz are delivered by respective finals to the post filters, then

$$P_{DC\ IN}^{449\ FINAL} = \left[ \frac{6.3}{0.5} - 2.2 \right] = 10.4\ WATTS$$

$$P_{DC\ IN}^{224.5\ FINAL} = \left[ \frac{3.9}{0.5} - 0.8 \right] = 7.0\ WATTS$$

$$P_{DC\ IN}^{DOUBLER} = \left[ \frac{2.2}{0.4} - 0.7 \right] = 4.8\ WATTS$$

$$P_{DC\ IN}^{224.5\ 2ND\ DRIVER} = \frac{0.7}{0.65} = 1.1\ WATTS$$

$$P_{DC\ IN}^{224.5\ (DOUBLER)} = \frac{1}{0.4} = 2.5\ WATTS$$

$$P_{DC\ IN}^* = 4.0\ WATTS$$

$$P_{DC\ TOTAL} = 29.8\ WATTS > 27.3\ WATTS\ available.$$

Therefore, to deliver 3.5 watts out of each antenna terminal requires slightly greater efficiencies than one could reasonably expect to attain out of a well-designed transponder.

Since the power supply efficiency is reasonably independent of the load, the input power level required at lower RF power output levels decreases almost in direct proportion.

The transponder was designed to operate with a minimum of primary power in the "standby" mode. The specification requires the maximum standby primary power not to exceed 1 watt. Table 3 indicates the standby power distribution of the transponder on a module basis.

The RF amplifiers, KMC 2N3880 transistors, were chosen on the primary basis of lowest noise figure available at 421 MHz. As common base RF amplifiers they exhibit very stable electrical characteristics, and lowest noise figures, but require  $\approx 70$  mw of input power.

The modulator/oscillator module supplies a standby L.O. to the receiver first mixer. The required stable L.O. is derived by multiplication (X24) from an 18.7 MHz reference carrier oscillator. The 150 milliwatts dissipation is the result of an extensive power reduction program. The X6 step recovery diode provides the theoretical  $1/n$  efficiency criteria (where  $n$  is the multiplication ratio). Since the hybrid isolator has a 3.5 db insertion loss, and the first mixer requires  $\approx 0$  dbm injection, then 75 MWs for the 75 MHz amplifier, 50 MWs for the X4 multiplier which includes losses in a 75 MHz 2-pole filter to reject the 18 MHz fundamental, and 25 MWs for a TCXO results in a reasonable power dissipation for the module.

The data amplifier/demodulator module provides a phase lock loop to track and detect the transmitted carrier, a correlation loop to command the power supply to the operation mode and the 11.225 MHz reference oscillator.

TABLE 3

MATS POWER REQUIREMENTS

<u>S. T. B. Y.</u>	<u>DIP (ma)</u>	<u>I-F (ma)</u>	<u>Demod. (ma)</u>	<u>Mod/Osc. (ma)</u>	<u>Total (ma)</u>	<u>Secondary Power (watts)</u>	<u>Primary Power (watts)</u>
+6V	7.0	38	12.5	13.5	71.0	.426	
-6V	6.5	18	20	11.0	55.5	.333	
Total	13.5	56	32.5	24.5	126.5	.759	1.26

This TCXO is again 25 MWs, and all 2N918 amplifiers are starved to 2.0 ma, (i. e., the lowest acceptable value consistent with worst case design practice). The DC amplifiers are integrated circuits  $\mu$ A 702As. Unless ICs are specifically designed for MATS standby voltages (which would be quite prohibitive based upon the small quantities used) then this 40-50 MW circuit type is the best that can be presently expected. The IF module provides  $\approx 120$  dbm of power gain under standby conditions to ensure that all effects of the environment will not degrade the performance of the transponder below the minimum required to bring it out of a standby condition. Thus, a power dissipation of  $\approx 25$  MWs/10 db gain is reasonable since the wide bandwidth required by each IF stage ( $\approx 15$  MHz) for a constant gain bandwidth product, allow only a small effective gain per stage. In addition to the above, frequency conversion, limiting, the VCO, etc. are also powered in the IF module.

The best power supply efficiency attainable under standby conditions is 60 to 65%, again via the route of bids, and investigation of other similar program supplies. Again the efficiency of the power supply is limited by the large primary voltage variation and the high degree of regulation of the output voltages required by the transponder.

An investigation is being pursued to further reduce the standby power, but one can appreciate the basic problems involved. Some obvious methods are to allow further starvation of stages, use phase lock rather than correlation detection to detect carrier acquisition, and reduce standby gains to marginal levels. We have shied away from these methods since an end result might be, for example: (1) poor repeatability on production units due to the specification controls required of starved stages, (2) confusion under some S/N conditions of carrier lock, and (3) reduced performance margins allowing only pretested, accountable effects to determine the receiver gain distribution.

### 3.3.8 Radio Frequency Interference

The transponder meets the requirements of Class I equipment as defined in MIL-I-11748B. This is basically a requirement to provide filtering at the transponder output the end result of which provides  $> 60$  db attenuation to all frequencies which are harmonically related to those transmitted and  $\geq 80$  db attenuation if non-harmonically related. The 8 pole, 449 MHz post filter provides  $\approx 48$  db/oct attenuation to all frequencies outside of the 3 db bandwidth and thus easily rejects all unwanted frequencies. The 2 pole 224.5 MHz post filter, providing a 12 db/oct slope, will reject the second harmonic 449 MHz by a minimum of 64 db. Sub-harmonic frequencies (related to 18.7 MHz fundamental crystal), are rejected by filters within the multiplication chain.

Radiation from other areas of the transponder should be minimal since precautions such as (1) providing RF shielded cables for all interconnections external to the modules, (2) completely enclosing the cables, (3) completely enclosed machined modules (providing excellent electrostatic shielding), (4) complete control of module ground locations to minimize the effect of electromagnetic radiation, and (5) shields grounded at both connector ends.

### 3.3.9 "Select Call" Circuit

Circuitry is provided within the transponder to recognize whether or not a "select call" signal is present and carry out the operation required to place the transponder in a "transmit" condition. The circuit is capable of being readily changed and fixed (by minor tuning and crystal insertion, etc.) to recognize a given subcarrier within the range of 400 to 600 KHz. The bandpass of the circuitry associated with the "select call" frequency is designed so that the -45 dbm to -115 dbm or other spurious transponder signals can not falsely trigger the transponder in a "normal" operate condition. The above holds true for all worst combinations of environment and voltage variations. Provisions are made to override the "select call" circuit from an external switching function

without having to insert a "select call" signal at the receiver input. The connections for the override feature terminate at an easily accessible point on an external connector.

The original specification requires a "select call" operation with composite subcarrier signals. This operation is not compatible with a high modulation index phase following type of transponder since proper control of the composite subcarriers by the ground stations is required to initiate the "select call" operation.

When the PFFB loop is not operative, that is, when the transponder transmitter is not operating, high index composite subcarriers entering the receiver can exceed the dynamic range of the phase detector. In addition, when passing through an index of 2.4 radians, the receiver phase lock loop can lose carrier lock since theoretically no carrier power exists at this particular index.

A simple replacement of the "select call" crystal filter is required to change the subcarrier frequency anywhere in the 400 to 600 KHz range or beyond.

The "select call" crystal filter is multiple pole, thus providing a skirt selectivity of  $\geq 12$  db/octave.

Subcarrier frequencies out of band are attenuated reducing the probability of falsely triggering the transponder into the transmit mode.

#### 3.3.10 Transmitter Output

The transponder transmitter is capable of providing either 1.5, 2.5 or 3.5 watts output from the transmitter terminals, which includes the diplexer, on both 224.500 MHz and 449.000 MHz. Choice of the desired output necessitates the selection of a power supply resistor, and minor tuning of the transmitter. Minor tuning and calibration is defined as the process required by a technician not thoroughly familiar with the transponder, but by reading

instructions, to tune and calibrate the transponder in a two-hour period using standard laboratory equipment for normal operation and performance as defined in other paragraphs of this document.

The reduced power output capability was discussed in paragraph 3.3.7.

The transmitter system power output change is accomplished by (1) changing the B+ voltage to the transmitter from 28 VDC to lower settings as defined in the alignment procedure and accomplished by changing a single resistor, located external to the power supply module and, (2) slight retuning of the transmitter module. Variable capacitors are provided with adjustments made using standard alignment tools.

#### 3.3.11 Antenna Input/Output

The transponder requires, at a maximum, two (2) antenna connections for reception of signals from the ground complex and transmission of the ranging and timing data back to the ground complex. A diplexer is provided as an integral part of the transponder, prior to the antenna output terminations, to allow reception of signals on 420.9375 MHz and the transmission of signals on 449.000 MHz. All output terminals, including the diplexer, are capable of handling either the 1.5, 2.5 or 3.5 watt output configuration. The insertion loss of the diplexer is no greater than 0.5 db.

The input/output impedance of all antenna connections is 50 ohms over the total bandwidth of interest. The VSWR does not exceed 1.5 for any frequency over the bandpass of interest.<sup>5</sup>

The sensitive receiver employed in the transponder has demanded an unusual degree of filtering at the receiver input and the transmitter output. The filters selected are both eight pole. Tuning of the diplexer, including both

<sup>5</sup> Refer to text for modification of this sentence.

filters, is performed as an integrated unit prior to integration with the transmitter and receiver. The resultant losses are as shown. See Figure 12.

Thus, as noted, the diplexer 0.5 db insertion loss for the 449 MHz signal is attained at the sacrifice of increased diplexer loss to the incoming 421 MHz signal. Again, an unfortunate circumstance due primarily to the close frequency spacing between the transmit and receive frequencies in combination with high modulation indexes that require large 3 db bandwidths.

It is impractical to check the VSWR of the transmitter outputs over the bandwidth since this would require driving the high power stages at frequencies widely separated from 449 MHz or 224 MHz, thus providing, in some cases, reactive loads, at full power, sufficient to exceed device dissipation. Therefore, the band of interest, as far as VSWR measurements, is taken to be center frequency only.

The VSWR requirement, as applied to the transponder receiver should be relaxed, since power match denoted by a VSWR of 1 does not provide a minimum receiver noise factor and thus, maximum transponder sensitivity. A VSWR of 2 is not uncommon, with a VSWR of 1.5 quite typical for best receiver noise figure.

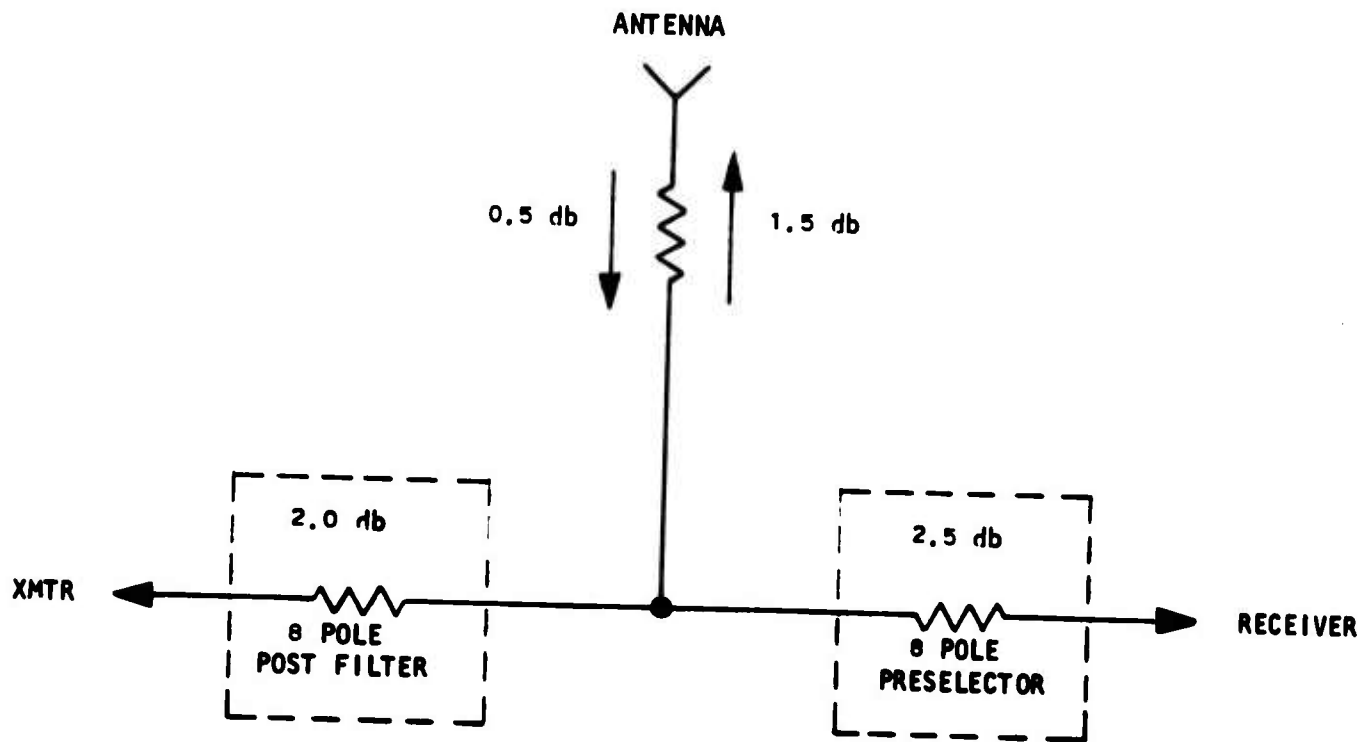

Figure 12

### 3.3.12 Bandpass

The overall bandpass of the transponder and data channels (including all subcarrier commands), is designed to minimize phase shift as defined in paragraph 3.4.3 while considering all system instabilities, any combination of modulation index, S/N, the effects of doppler and all other requirements defined in this document. Some of the system considerations are:

(1) the maximum radial velocity of the satellite which contains the transponder is that associated with an elliptical orbit whose perigee is 200 N. miles and whose apogee is 2000 N. miles in altitude;

(2) <u>Frequency</u>	<u>Stability</u>
a. 420.9375 MHz carrier	0.001%
b. All subcarriers	0.005%

(3) modulation indexes of the individual ranging or timing subcarriers lie within the range of 0.5 to 2.5 radian; (4) the transponder ranging data signal-to-noise ratio is +12 db as defined in paragraph 3.4.11.

Analysis derives the closed loop performance of the transponder as related to open loop parameters. The primary open loop parameters of importance being  $\Delta\mu$ ,  $\Delta\omega$  and  $K_{\mu}$ .

Refer to the MATS transfer function Block Diagram, Figure 5 and compare it to the functional Block Diagram, Figure 1. Since the takeoff point for PFFB occurs at the output of the 449 MHz transmitter final amplifier, the only circuit incorporated into the feedback path is a 2-pole cavity filter. This filter's primary function is the elimination of undesirable L. O. frequencies, mainly the 224.5 MHz. Calculating envelope time delay associated with this filter, we have:

$$t_{\text{envelope}} = \frac{\Delta\omega \text{ radians}}{\Delta\omega \text{ radians}} (n) \quad (1)$$

where  $t_{\text{envelope}}$  = envelope delay of the bandpass network.

$n$  = number of poles in the network

$$\begin{aligned}\Delta O(n) &\cong 90^\circ \text{ linear phase shift between 3 db points for each pole.} \\ &= 1.57 \text{ radians}/90^\circ\end{aligned}$$

$\Delta\omega$  = 3 db bandwidth in radians for each pole.

$$\text{therefore } t_{\text{envelope feedback path}} = \frac{1.57}{50 \times 10^6 (2\pi)} \times 2 = .01 \mu\text{sec}$$

Although cavity filters exhibit time delay stabilities much better than 10%, for argument's sake the benefit of the doubt is given the reader. Thus

$$\Delta t_{\text{feedback path}} = .1 \times .01 = .001 \mu\text{sec}$$

which at 600 KHz (i.e., the worst case highest modulating frequency), yields

$$\tau_{600 \text{ KHz}} = 1.67 \mu\text{sec}/360^\circ$$

and

$$\Delta \alpha_{\beta} = \frac{(.001)(360)}{1.67} = 0.215 \text{ degrees}$$

for

$$K_{\mu\text{R}} = 30$$

then

$$\frac{\Delta \alpha_0}{\Delta \alpha_{\beta}} \cong -1$$

$$\Delta \alpha_0 \Big|_{\Delta \alpha_{\beta}} \cong -0.215^\circ$$

TABLE 4

Module	(usec) Envelope Delay	(usec) Change in Delay	(degrees) Change in Phase
IF	0.136	0.0136	1.75
Demod/Decod (Excluding Crystals)	0.0312	< 0.00312	0.67
Phase Mod/Osc	0.207	< 0.02	4.3
Transmitter	0.037	< 0.0037	0.8
Crystal Filters	2500.0	----	60.0

Thus, the output phase change exhibited by the transponder due to  $\Delta\alpha_u$  is minimal.

Table 4 summarizes the results of a similar analysis for the forward loop portion of the transponder on a module basis. The changes in envelope delay were arbitrarily taken as 10% for each module (except the crystals). This is typical of the performance exhibited by the breadboard transponder over complete environment and signal level changes related to the S/N ratio and modulation index variables. Without the crystal filters we have

$$\Delta' \alpha_u = 7.52$$

noting that

$$\Delta \alpha_u \text{ crystals} = 60^\circ$$

and

$$\Delta \alpha_u = \Delta \alpha_u \text{ (crystals)} + \Delta \alpha'_u$$

$$\Delta \alpha_u = 67.5^\circ$$

since

$$\Delta \alpha_u \text{ crystals} \gg \Delta \alpha'_u$$

then

$$\Delta \alpha_u \approx \Delta \alpha_u \text{ crystals}$$

Thus the choice of crystals becomes an all important parameter in the design of a phase stable transponder. Since a DD type crystal cut is the most temperature stable as compared to the other alternatives of DT, and CA, this type was chosen. An unfortunate byproduct of its superior temperature stability is spurious products at undesirable frequencies of sufficient magnitudes to cause loop stability problems. Considerable effort was devoted in the demodulator

design to negate the spurious effects. The results allowing the use of a crystal with  $\Delta \tau_{\text{crystal}} = 60^\circ$  max. Since most of the phase shift occurs between 23°F and -4°F, it is reasonable to expect the  $\Delta \alpha_0$  performance outside of this temperature range to be correspondingly improved.

Since 
$$\frac{\Delta \alpha_0}{\Delta \tau_{\mu}} = \frac{1}{k_{\mu g}} = \frac{1}{30}$$
 then 
$$\Delta \alpha_0 |_{\Delta \tau_{\mu}} = 67.5 / 30 = 2.25^\circ$$

Some circuitry exists outside of both the forward and feedback paths, namely the diplexer, RF amplifiers and associated filters. Refer to Table 5 for calculation results. The total  $\Delta \alpha_0$  with respect to these circuits is

$$\Delta \alpha_0 \text{ out of loop circuits} = 2.5^\circ$$

Notice that the Diplexer filters were allowed a 10% change in delay. Again we are being ultra conservative since, for cavity type filters, the actual delay change is <1%.

TABLE 5

<u>CIRCUIT</u>	<u>ENVELOPE DELAY</u> <u>(usec)</u>	<u>CHANGE IN DELAY</u> <u>(usec)</u>	<u>CHANGE IN PHASE</u> <u>(Degrees)</u>
Pre Selector	.05	.005	1.07
Post Filter	.05	.005	1.07
RF Amplifier	.0063	.00063	.136
Other Filters	.0083	.00083	.178

Thus, from the above we can calculate the  $\Delta \alpha_0$ .

$$\begin{aligned} \Delta \alpha_0 \text{ calculated} &= \Delta \alpha_0 \text{ out of loop circuits} + \Delta \alpha_0 \text{ respect to forward loop} + \Delta \alpha_0 \text{ respect to feedback loop} \\ &= 2.5^\circ + \frac{67.5}{30} + 0.215 \\ &= 2.5 + 2.25 + .215 \\ &= 5^\circ \end{aligned} \quad (2)$$

In practice, with the breadboard transponder, it has been found that  $\Delta\omega_c/\Delta\omega_u$  has been by far the predominant factor and thus equation (2) can be rewritten

$$\Delta\omega_{c, \text{actual}} \approx \Delta\omega_c \Big|_{\Delta\omega_u}$$

or even more simply, and almost as accurately

$$\Delta\omega_{c, \text{actual}} = \Delta\omega_c \Big|_{\Delta\omega_{u, \text{crystal}}} \quad (3)$$

denoting that the choice of this crystal filter is of major importance to the design of a phase stable transponder, assuming all other factors, due to careful design, can be neglected. This case applies to the MATS transponder and is all important to its future potential.

As far as those parameters relating to frequency stabilities and associated orbital parameters, they are used primarily for specifying the phase lock loop parameters along with the stabilities of those oscillators associated with the transponder itself.

A most unique problem is that of a carrier acquisition. Because the satellite is moving past four ground stations at geographically different locations, and with slightly differing RF carrier frequencies, the transponder must be prepared to perform the carrier acquisition process anew on each received pulse in the SECOR transmission frame sequence. Thus, in a period of 50 ms, the transponder will encounter four different carrier frequencies with four different doppler offsets. Acquisition and de-acquisition must be virtually instantaneous.

The system designed to meet the requirements of the purchase specification is shown in the block diagram, Figure 1. The system consists basically of two loops in parallel. One is the carrier phase locked loop, and the other is the phase following feedback loop. They are not, however, independent.

The gain of the carrier loop is a function of carrier level, and as such, is a function of the feedback gain of the PFFB loop. Further, the detection of the subcarriers is done in the phase detector by product detection. The output of the product detector is given by:

$$E_0 = k \sin (\theta_{dc} + \theta_1 \cos p_1 t + \theta_2 \cos p_2 t + \dots) \quad (4)$$

For  $\theta_{dc} + \theta_1 + \theta_2 \ll 1$  radian, the output would be linear and the output levels would be independent. It is evident that in analyzing loop stability (i. e.  $\theta \rightarrow 90$  degrees) the two loops must be treated as one.

Rather than treat the problem of interdependence analytically, we chose to present a subjective analysis. This is justified since the nonlinear analysis required to solve the problem is not adequately solved at this time.

Let us take two practical cases: Case I, high S/N ratio in both loops, Case II low S/N condition within the PFFB loop.

Case I: High S/N ratio ensures that the signal power is  $\gg$  noise power within the PFFB loop. For  $K_{\mu q} = 30$  we have

$$m_{pd} = \frac{m_i}{1 + K_{\mu q}} \quad (5)$$

where

$m_{pd}$  = modulation index presented to phase detector

$m_i$  = modulation index received by transponder

solving for highest  $m_{pd}$  we have

$$m_{pd} = \frac{15 \text{ radians Peak}}{1 + 30} = 0.484 \text{ radians peak}$$

Thus, a linear condition prevails within the phase detector and the PFFB and carrier loops are for all practical purposes independent.

Case II: Low S/N ratio is defined as that level in which the noise power within the PFFB loop is sufficient to momentarily prevent the loop from tracking the phase of the incoming modulation. As the tracking error increases, equation (35) becomes

$$m_{pd} = \frac{m_i \epsilon}{1 + K_{\mu q}}$$

where

$\epsilon$  = factor relating to the PFFB tracking error.

$\epsilon \rightarrow 1$  for negligible error

$\epsilon \rightarrow (1 + K_{\mu q})$  as the tracking error approaches  $\geq 90^\circ$ .

As the loop S/N ratio approaches threshold and below

$$m_{pd} \rightarrow m_i$$

and the phase detector output can no longer linearly detect the modulation. Since carrier level is a function of the modulation index and the PLL gain is a function of carrier input level, then one can easily accept the fact that the carrier loop can lose lock for weak transponder input signals.

The basic requirements for the system to be sequentially interrogated by four ground stations in 10 ms bursts with 2.5 ms spacing between bursts, establishes the following operating criteria for the transponder:

- (1) The phase locked loop must initially acquire to turn the transmitter on.
- (2) The phase locked loop must reacquire every 12.5 ms upon a different carrier frequency.
- (3) All transient responses of the previous station must die down in 2.5 ms.

Since several hundred milliseconds are allotted to initial transmitter turn-on, and the time delay for turn-off is at least seven seconds, the first requirement does not impose any difficulty. The main concern in this area is to set the select call threshold sufficiently high to ensure a low probability of false alarm turn-on due to noise peaks. Diodes, in conjunction with filter bandwidths wide enough to pass only the highest select call modulation rate (i.e., 20 pps with a 15% duty cycle), satisfy the requirement.

The need for reacquisition every 12.5 ms, and the transient response requirement impose some difficulty, unless the transmitted signal is properly shaped to allow the feedback loops to respond. A recommended signal shape would be that shown in Figure 13. The carrier alone would be on for 0.5 ms; then the modulation would be applied gradually for the next 2.5 ms. Full modulation would exist for an additional 5.5 ms, and then the modulation level would drop off to zero in 2.5 ms with the carrier off after another 0.5 ms.

The bandwidth of the phase locked loop must be sufficient to acquire the carrier in the 0.5 ms under all conditions of possible carrier frequency uncertainty. This uncertainty is due to doppler, oscillator instabilities, and dc offsets in the voltage controlled oscillator loop. They are as follows:

- Doppler uncertainty ±12 KHz
- Received Signal Frequency  
0.001% Stability at 42/MHz ± 4.2 KHz
- VCO Stability ± 3.9 KHz
- Reference oscillator stability ± 1.6 KHz
- Local Oscillator Instability  
0.0005% at 449 MHz ± 2.25 KHz
- Phase Detector DC Offset  
1 mv at 15 KHz/volt ± 4.5 KHz

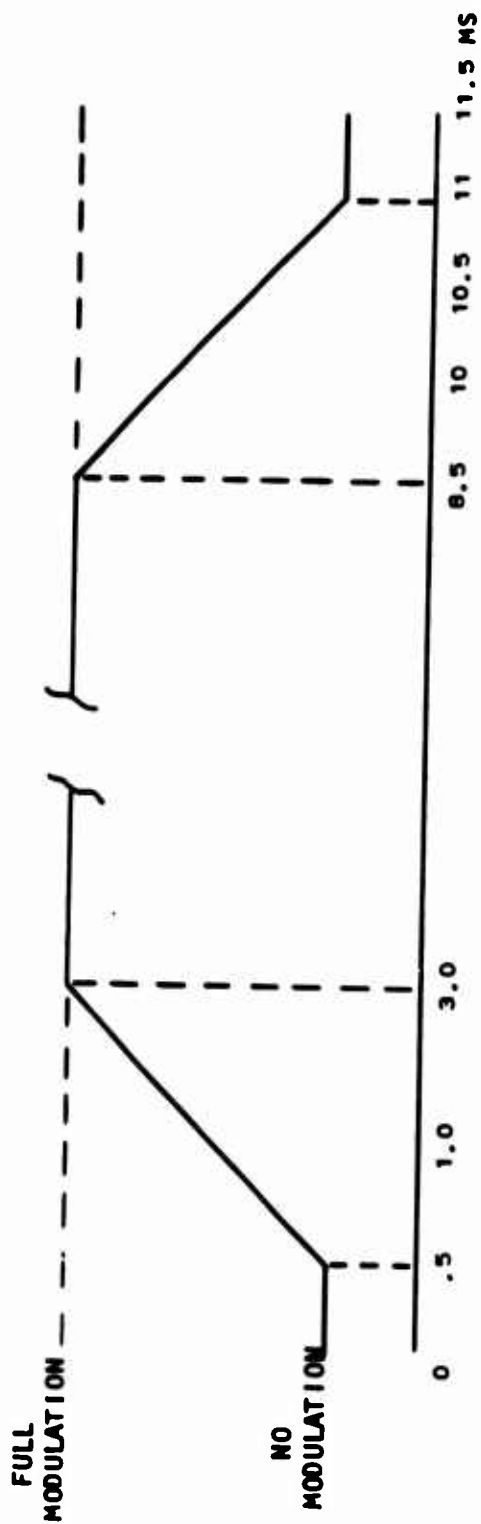

Figure 13 INTERROGATOR TRANSMITTED MODULATION WAVEFORM

The maximum error would be approximately 28.5 KHz. The time required for carrier lock is

$$t_L \geq \frac{K (\Delta f)^2}{f_{nn}^3}$$

where  $f_{nn}$  is the lowpass bandwidth of the loop,  $\Delta f$  is the frequency uncertainty, and the constant  $K$  is a function of the damping constant of the loop, equal to approximately 4 for a minimum noise bandwidth loop.

$$f_{nn} = 30 \text{ KC (Refer to Figure 14 for open loop Bode plot)}$$

$$K = 4 \text{ (for a 0.7 damping factor; MATS loop)}$$

$$\Delta f = 28.5 \text{ KHz}$$

$$t_L \geq \frac{4 (28.5 \times 10^3)^2}{(30 \times 10^3)^3} \geq 116 \text{ usec}$$

Thus, the allowable lock-up time of 0.5 usecs assures carrier acquisition. One should note that the above lock time is modified somewhat by the constantly changing loop bandwidth  $f_{nn}$ .

The bandwidth change occurs since the loop gain can be as much as 15 db less after acquisition than before, (Refer to Figure 14), due to coherent AGC action.

$$f_{nn} \text{ after acquisition} = 5 \text{ KHz}$$

The S/N of the loop for an input signal of -115 dbm before acquisition is

$$S/N = 115 - KT \cdot B \cdot F$$

where

4

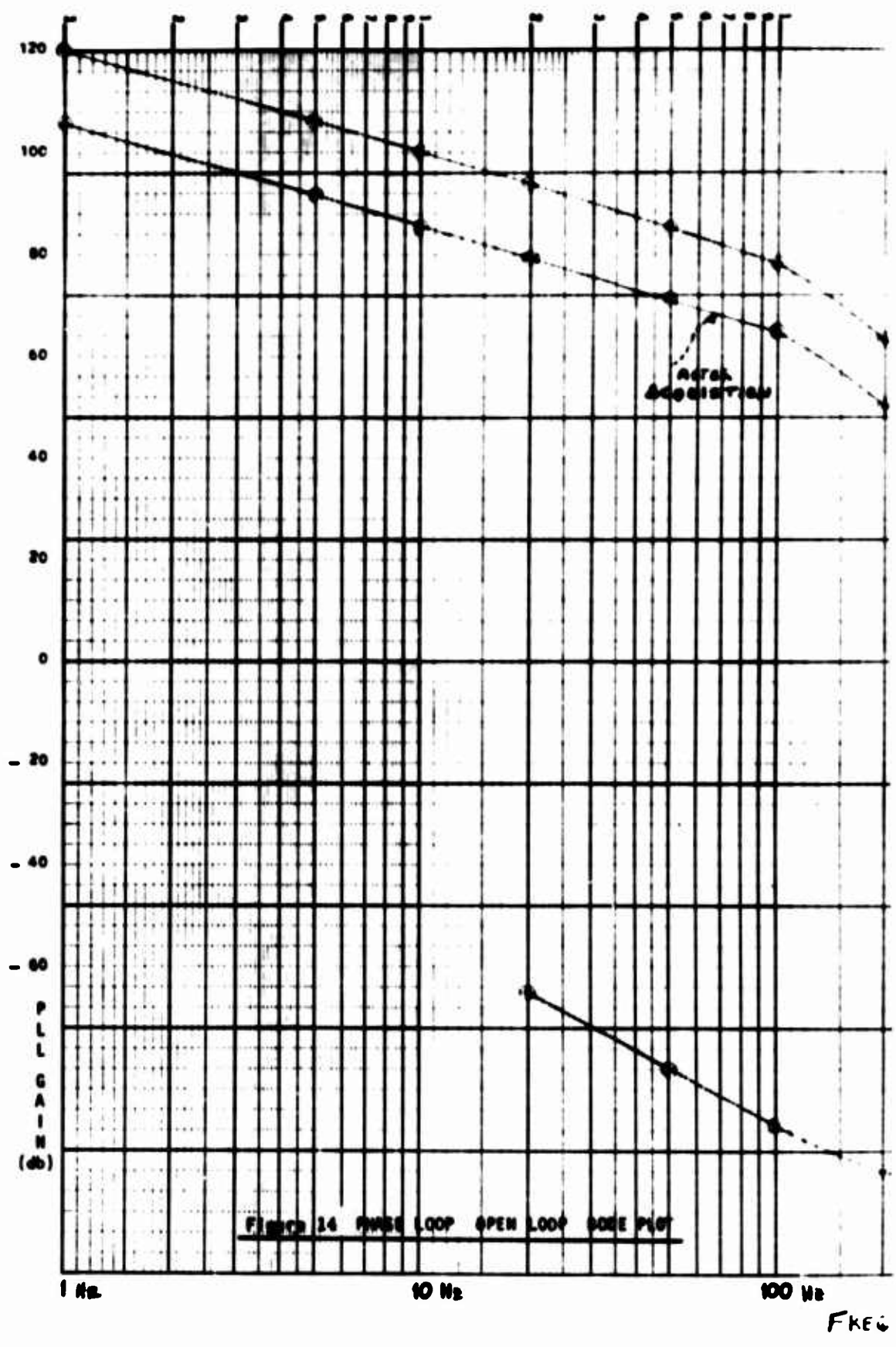
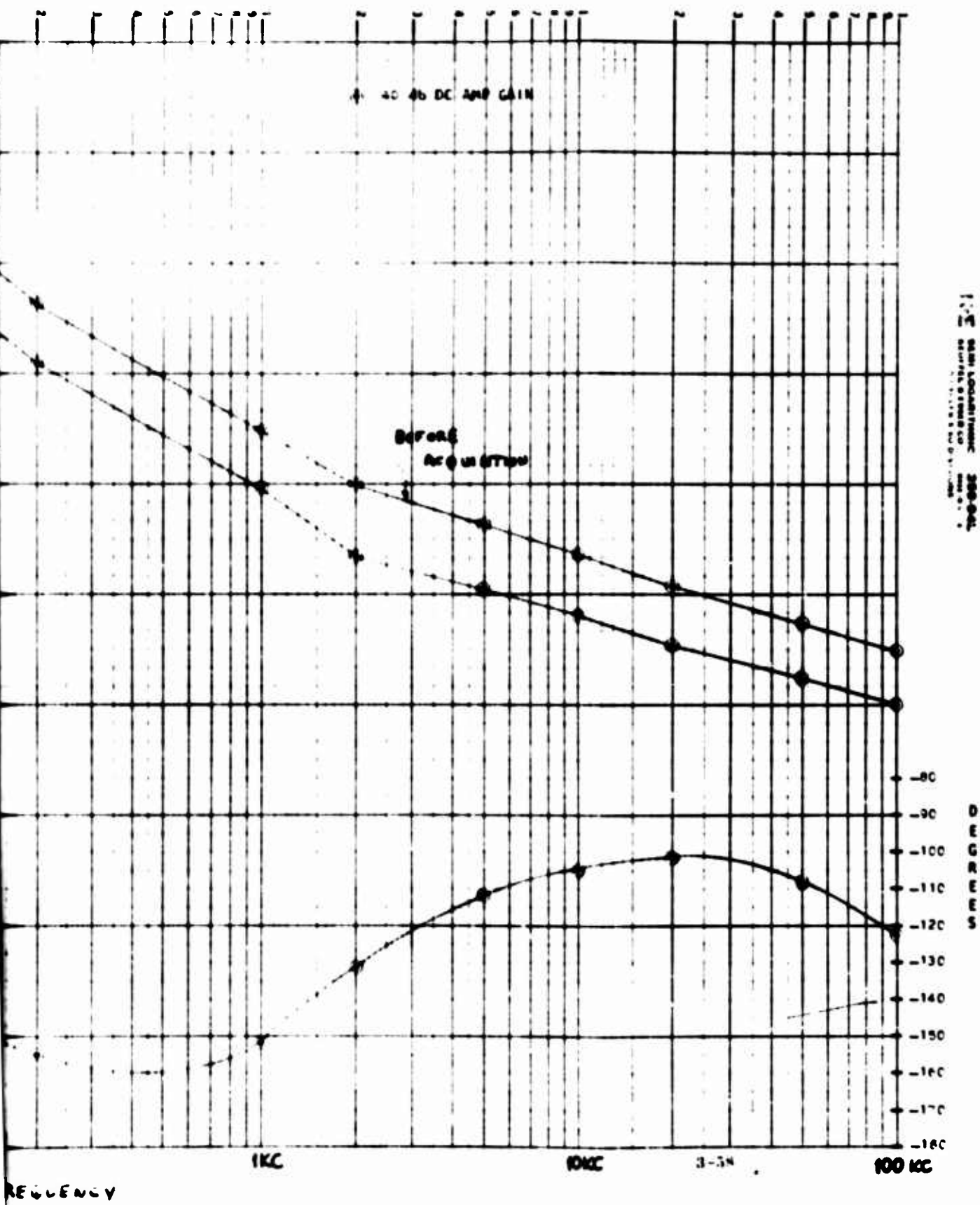

FIGURE 14 PHASE LOOP OPEN LOOP GAIN PLOT

12



1-5  
SAMI LABORATORIES  
RESEARCH & SERVICE CO.  
11111 1/2 S. 11th St.  
MINNAPOLIS, MINN.

$$KT = 174 \text{ dbm/Hz}$$

$$B = 30 \text{ KHz or } 45 \text{ db}$$

$$F = \text{Noise figure} = 9 \text{ db}$$

$$S/N = +5 \text{ db before acquisition}$$

$$\begin{aligned} S/N \text{ after acquisition} &= -115 + 174 - 37 - 9 \\ &= +13 \text{ db} \end{aligned}$$

Both figures are well above the threshold of a carrier loop where

$$\begin{array}{l} S/N \quad \quad \quad \approx +1 \text{ db} \\ \text{Loop threshold} \end{array}$$

Figure 15 shows the MATS PLL acquisition performance locking on a carrier +10 KHz above 420.9375 MHz, to unlock, then 420.9375 MHz -10 KHz, to unlock, and repeat.

$$\begin{array}{l} T_L \quad \approx 100 \text{ usec.} \\ \text{Actual} \end{array}$$

S/N threshold is measured at  $\approx -123$  dbm RF signal input to the transponder, (i.e. threshold defined as a 100 Hz unlock to lock rate for a carrier 10 KHz from center frequency).

The slope of the increase in modulation must be such as not to cause the loop to break lock and cause the narrow band crystal filter to ring. The criteria for breaking lock is that the peak phase error of the loop exceeds 90 degrees.

The phase modulation PFFB loop is represented in Figure 16. The filter response is the lowpass equivalent of the bandpass filter. The variable(s) will thus be transformed to a variable about the resonant frequency of the filter.

The transfer function of the loop

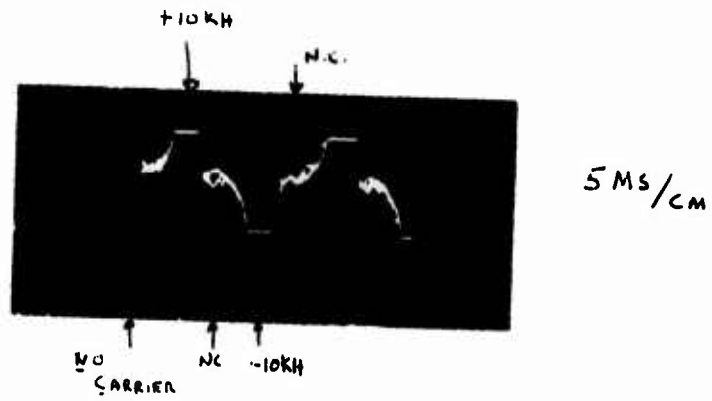

NOT REPRODUCIBLE

Figure 15 PLL Performance, Dynamic

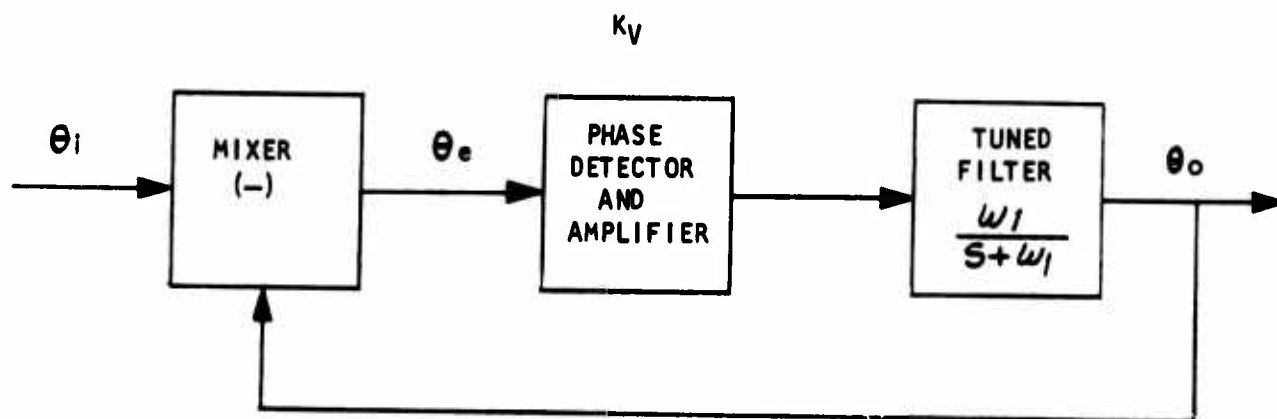

Figure 16 PHASE MODULATION COMPRESSIVE FEEDBACK LOOP

$$H(S) = \frac{K\omega_1}{S + \omega_1}$$

or

$$\phi_e = \frac{S + \omega_1}{S + (K + 1)\omega_1}$$

Expanding into a Maclaurin's Series,

$$\phi_e = \frac{1}{K + 1} \phi_i + \frac{K}{(K + 1)^2} \phi_i$$

For the ramp in phase illustrated (Figure 13)

$$\phi_i = \frac{2.5 \text{ radians}}{2.5 \times 10^{-3} \text{ seconds}} = 1000 \text{ radians/second}$$

The transponder uses crystal filters having 100 cps 3 db bandwidths. Thus, the lowpass equivalent of  $\omega_1 = 27 \times 50$  cps and  $\phi_e$  due to the ramp is equal to (for  $K = 30 \text{ db} = 31.6$ )

$$= \frac{31.6 \times 1000}{(32.6)^2 \times 2 \times 50} = 0.94 \text{ radians}$$

However, the overall system will have phase errors introduced due to the ramp of each subcarrier, the frequency error, noise jitter, and the phase modulation of the subcarriers themselves. These errors will be cumulative, as previously explained, and could prevent lockup. The detected signal from the phase detector will be:

$$E_o = k \sin (\phi_{dc} + \phi_1 \cos \rho_1 t + \phi_2 \cos \rho_2 t \dots + \phi_{\text{ramp}}$$

$$[ f(\rho_1) + f(\rho_2) \dots + \sigma_n + \dots ]$$

As this error approaches 90 degrees, the differential gain for additional error falls to zero and the loop becomes unstable.

Assuming a peak modulation index due to all subcarriers of 15 radians, the error due to the ramp will be 0.56 radians.

The signal-to-noise ratio in the lowpass loop is a minimum +13 db after acquisition. The signal-to-noise ratio in each subcarrier loop at 2.5 radians of deviation is approximately 20 db. At 0.5 radians, the S/N will be +6 db.

$$\begin{array}{l} \text{S/N} \\ \text{each subcarrier} \end{array} = -KT - S - B - F + M_I$$

where

$$B = 100 \text{ cps} \times \text{PFFB ratio} \times Q$$

$$= 6220 \text{ cps or } 38 \text{ db}$$

$$Q = \text{conversion factor from } 3 \text{ db bandwidth to noise bandwidth}$$

$$Q = 2 \text{ (refer to Appendix C for calculation)}$$

$$M_I = 2.5 \text{ radian or } 8 \text{ db}$$

$$F = 9 \text{ db}$$

$$S = 115 \text{ dbm}$$

$$KT = -174 \text{ dbm/Hz}$$

$$\begin{array}{l} \text{S/N} \\ \text{each subcarrier} \\ 2.4 \text{ radian} \end{array} = 174 - 115 - 38 - 9 + 8 = +20 \text{ db}$$

One should note that if only one subcarrier is used, but the other 5 are not, then during a S/N measurement

$$\begin{array}{l} \text{S/N} \\ \text{measured} \\ 2.4 \text{ radian} \end{array} = 20 \text{ db} - B_T$$

where

$B_T$  = Noise BW of all subcarrier channels

= 6 B. An 8 db greater noise bandwidth than required for the "one" subcarrier under measurement.

The signal-to-noise ratio during the phase ramp is a variable, being a function of the modulation index. The phase jitter ( $\epsilon$ ) is a function of S/N.

$$\epsilon_{\text{rms}} = \frac{1}{(S/2N)^{1/2}}$$

The cumulative errors during the ramp will be as follows:

- $\epsilon$  error (ramp) 0.56 radians
- PLL error due to frequency uncertainty 0.1 radians
- Noise Error (rms)
  - Lowpass filter 0.22 radians
  - Subcarrier filters 0.10 radians
- $\epsilon$  error at 15 radians peak  $\frac{15}{31.6} = 0.427$  radians

The overall error at -115 dbm is approximately 1.4 radians rms. The system will be stable, if not linear, during the ramp input.

The gain of the PLL loop is sufficient to reduce the phase error (for a frequency offset of 28.5 KHz) to .10 radians. This will require a loop gain of greater than:

$$G \geq \frac{28.5 \times 10^3 \times 2}{0.1} = 1.8 \times 10^6$$

This is obtained with the following gain constants:

- $K_{\phi}$  - phase detector gain: 0.2 volts/radian
- $K_{dc}$  dc amplifier gain: (voltage) 40 db
- $K_{VCO}$  voltage controlled oscillator constant: 12 KHz/volt

### 3.3.13 Grounding

The case of the transponder is isolated from the primary power system. In this regard, DC isolation is  $1\text{ M}\Omega$ . The outer case is used only as RF ground.

The primary power is supplied to the transponder power supply using a floating ground system to isolate the transponder case from the primary power system ground. Although isolation at 100 KHz was originally specified at 100 K $\mu$ , capacitance from the primary to case ground was required to reduce RFI problems within the power supply. The infinite DC resistance originally specified is, of course, not practically possible. A DC resistance  $1\text{ M}\Omega$  was found to be a reasonable value for the present design.

### 3.3.14 External Cables

All external cabling other than that utilizing coax, are shielded to the highest degree practical. All shielded cable is grounded (RF ground) at both ends and is of low capacitance. No shield is used as a common return except for RF. Since more than one package is used, provisions are made for a positive electrical RF bond, in a stacked condition, between all package modules.

All cables, external to the modules and carrying RF, are a coax type. The shielded outer conductor is RF grounded on both ends and, when possible, terminated by an impedance equal to the characteristic of the line (i.e.,  $Z_0 = 50\Omega$ ). Non shield cables occupy the same cable channel as the RF cables. The entire cable channel is RF shielded from the external environment by an aluminum cover plate. The individual modules are machine fitted (to a flatness and parallelism specification) to provide a positive RF bond between them.

### 3.3.15 Transponder Warm-Up/Shut-Down Properties

The transponder is operating and in a condition to perform as defined in paragraph 3.4, under the worst combination of environmental, voltage variation and dynamic range conditions defined in paragraph 3.3.6, 3.3.7 and 3.4.1, respectively, within 6 seconds after the receipt of a "select call" subcarrier or the activation of the "select call" override as defined in paragraph 3.3.9.

The transponder remains in the "transmit" condition, under the same conditions defined above, at least 7 seconds, but not more than 15 seconds, after the termination of the "select call" subcarrier or the deactivation of the "select call" override as defined in paragraph 3.3.9. This holds true for pulsed "select call" signals where the pulse rate is 20 PPS with carrier on duty cycles of 15 percent or more.

Since the transponder is completely solid state, the original warm-up time of 60 seconds is not required. The specification can be changed to 6 seconds. The effect of this change is to reduce the total energy expended by the satellite power source, during a transmit condition. For example, for three (3) 10-minute transmit periods per day, we have:

$$\text{Xmit Energy/10 minute period} = \text{Xmit power} \times .167 \text{ hrs (i. e. 10 min)}$$

$$= 39 \text{ watts} (.167 \text{ hrs}) = 6.5 \text{ watt-hrs}$$

$$\text{Xmit Energy/3 - 10 min orbits} = \text{Xmit Energy/day} = 6.5 \times 3$$

$$= 19.5 \text{ watt-hrs}$$

$$\text{Xmit Energy for warmup} = 39 (.05) = 1.95 \text{ watt-hrs}$$

(.05 = 30 sec / 600 sec)

Therefore

$$\text{Total useful energy/day} = 19.5 - 1.95 = 17.5 \text{ watt-hrs}$$

Since a maximum allowable warm-up of 6 seconds is sufficient, then the total useful energy per day is approximately 19.5 watt-hours; or for the same 17.5 watt-hours/day as above the transmit power could be  $39 \text{ watts} + .1 (39) = 42.9 \text{ watts}$ , (i. e., the expended energy in both cases would thus be equal).

An automatic time delay circuit is incorporated into the power supply module to return the transponder to a 'receive' condition upon termination of the "select call" signal, and a "minimum" power drain condition (i. e., "standby") after termination of the coherent carrier.

### 3.3.16 Telemetry Sensors and Outputs

Certain telemetry parameters are provided within the transponder in order to obtain housekeeping data while in orbit. The circuits required to provide the parameters are integral to the transponder and consist of the following.

#### 3.3.16.1 Thermal Sensors

Three (3) thermal sensors are placed in the transponder; one (1) is placed on the case of the power supply; one (1) on a structure in close proximity to the transmitter output; and one (1) on a structure in close proximity to the ranging subcarrier filters and amplifiers. The thermal sensors have a range that covers the expected temperature within the areas of interest when subjected to the Thermal Vacuum test defined in paragraph 4.3.5. (This does not include non-operating storage conditions.) The thermal sensors are of the Fenwal iso-curve type. The sensors have a maximum thermal time constant commensurate with overall system consideration. The isolated leads of the thermal sensors are brought to an external connector on the transponder for use in an external telemetry system. The thermal sensors are passive in that power for these circuits are not provided within the transponder, but from an external source.

### 3.3.16.2 Input Signal Strength Monitor

An active (powered internal to the transponder) circuit is provided within the transponder which is used to indicate the received signal strength at the receiver input of the transponder. The output is in the range of 0.5 to plus 5 VDC, over the dynamic range of -45 dbm to -115 dbm, with external loads of 5,000 ohms or less shunted by 150 micro-micro farads of capacitance. Indications of signal strength are available when the receiver is either in the "receive" or "transmit" condition. All circuits required to provide the above output are power internal to the transponder configuration. The output leads are routed to an external connector on the transponder for use in external telemetry systems. The presence or absence of the above load does not damage the transponder or affect its performance as shown in paragraph 3.4 under the worst combination of environment, voltage variation and dynamic range. The input strength output is approximately logarithmic. At the given temperature, the resolution of the output is  $\pm 2$  db. The output has an overall reading accuracy, including resolution and stability, over the worst combination of environment conditions and dynamic range of  $\pm 5$  db for a period of one year.<sup>6</sup>

Since the transponder contains two types of AGC (1) non-coherent (signal plus noise)AGC and (2) coherent (signal)AGC, the signal strength indication over the -45 dbm to -115 dbm range is shared between two outputs. The range -45 to -95 dbm is covered by the signal plus noise AGC. The remainder is covered by the signal AGC. The signal AGC is fed to telemetry on the same line as the "frequency acquisition" indicator. In the interest of conserving power to the maximum extent possible in the "standby mode," the AGC circuitry is not turned on until an inband carrier provides a correlated output from the detector, placing the transponder in the "receive" mode.

---

<sup>6</sup> Refer to text for some proposed changes.

The original specification uses words "approximately logarithmic" to define the signal strength monitor characteristic. This should be redefined with reference to the actual curves obtained, since the words are too subjective to accurately denote the output characteristic.

### 3.3.16.3 Power Output Monitor

An active (powered internal to the transponder) circuit is provided to indicate the power of the 449.00 MHz transmitter output. This circuit is capable of providing outputs within an 0 to plus 5 volts DC range for either of the 1.5, 2.5 or 3.5 watt output configurations. The output voltage of this circuit versus the output power of the transponder is stable within  $\pm 10\%$  of maximum reading and approximately linear over all conditions of environment and voltage variations defined in this document.

This circuit is capable of driving 5000 ohms shunted in parallel with 150 micro-micro farads. When the transponder is in a "standby" condition, the voltage out of this circuit is "0" volts. All circuits and power required to provide the output described above, are an integral part of the transponder. The output leads are routed to an external connector on the transponder for use in external telemetry systems. The presence or absence of the above load does not damage the transponder or affect its performance as called out in paragraph 3.4 under the worst combinations of environment, voltage variation or dynamic range.

The original output linearity specification of 5% is too tight for simple RF diode detection circuitry. Unless one can justify the additional circuitry required to linearize this function, it is hoped that the present circuitry is adequate.

The plus 0.5 volts originally required during "standby" is not provided, since no power is supplied to the transmitter module during standby.

#### **3.3.16.5 Automatic Phase Control and Frequency Acquisition Voltage**

Two outputs, indicative of Automatic Phase Control and of Frequency Acquisition, are provided. The output impedance of these circuits is  $< 600$  ohms. These circuits are capable of driving loads of 5000 ohms or less, shunted by 200 microfarads capacitance at levels between 0.5 and 5.0 volts for the output range. Each output is plotted for each transponder.

The APC monitors the error voltage of the phase lock loop through a buffer amplifier whose output impedance is  $\approx 150$  ohms. The Frequency Acquisition output monitors the correlation detector output which also indicates coherent AGC voltage. The output impedance is  $\approx 500$  ohms.

#### **3.3.17 Transponder Detector Output**

An output is provided from the output of the transponder detector. This output is used to drive command circuits external to the transponder. Access to this circuit is available at an external connector. The output impedance of this circuit is 600 ohms or less. This circuit is capable of driving a load of 5,000 ohms or less shunted by 200 micro-micro farads capacitance at a level of at least 0.5 volts RMS. Insertion or removal of a load as defined above does not damage the transponder or degrade its performance as called out in paragraph 3.4 under any worst combination of environment, primary voltage variations and dynamic range.

The phase detector output is fed to a wideband video amplifier providing a level of at least 0.5 V RMS of composite signals, including wideband noise. Individual signal amplitudes are a function of their modulation index. The noise level is a function of the carrier signal level into the transponder.

### 3.3.19 Command Frequency Outputs

Two output circuits are provided within the transponder which are used for command signal outputs. The circuits operate on subcarriers within the range of 400 - 600 KHz and utilize crystal filters in the same manner as the select call circuit. The output impedance of these circuits is 600 ohms or less and capable of driving loads of 5000 ohms or less shunted by 150 micro-farads at levels of at least 1.0 volts RMS. Bandwidth of the filter circuits is 100 cps. They provide a S/N improvement of 40 db or a total S/N of at least 19 db with input signal levels of -115 dbm.

The command signal is not part of the loop. Detection bandwidth is the bandwidth of the crystal filter. The modulation index for the command subcarrier is 0.5 radian.

The S/N is given by

$$S/N = -KT - 115 \text{ dbm} - B - F + \Theta_m$$

where

$$B = 100 \text{ cps} = 20 \text{ db}$$

$$\Theta_m = 0.5 \text{ radians} = -6 \text{ db}$$

$$F = 9 \text{ db}$$

$$S/N = 174 - 115 - 20 - 9 - 6 \text{ db} = 24 \text{ db}$$

$$S/N = 24 \text{ db}$$

Thus the +19 db is easily met. The crystal filters are multiple pole types where the 3 db bandwidth is a good approximation to actual noise bandwidths. The mod.index can be anywhere within 0.3 to 0.5 radians. Higher indexes can be used if all other subcarriers are not on simultaneously. A buffer amplifier provides a low impedance drive of  $\approx 150$  ohms to the telemetry. It would be helpful if the original 1.5 rms output specification were reduced to 1.0 v rms, since a special alignment procedure is required to obtain the full 1.5 rms swing.

### 3.3.21 Limiting

Positive transistor limiting is included both in the receiver and transmitter sections of the transponder. Transistor amplifiers whose characteristics are suited to provide symmetric limiting (cutoff and saturation points) are used in place of the more common diode limiters. These limiters are convenient and provide equal charge and discharge paths for both positive and negative voltage clipping.

### 3.4 Performance

The transponder performs in the manner called out below under the worst combination of environment, primary input voltage variations, and dynamic range.

#### 3.4.1 Dynamic Range

The transponder performs and operates as per specification (Section V) over input power ranges from -45 dbm to -115 dbm with any combination of fixed frequency subcarriers defined in paragraph 3.1.1.

As mentioned previously, both signal plus noise and signal AGC circuitry are used to cover the complete dynamic range. The signal plus noise AGC is of the reverse type in order to provide a large control range. Under usual circumstances, a design based upon reverse AGC would suffer from poor dynamic range and large variations in transistor parameters, but since the IF strip uses integrated circuits, where multiple active circuits are contained within each unit, the old transistor "cliches" are not necessarily valid. For the circuits chosen, reverse AGC doesn't adversely affect either the transistor operating points, dynamic range, linearity or input-output impedance, but does provide a constant signal output over wide variations in input level. The gain control per stage is controlled from cutoff to maximum gain. The detection bandwidth is 2 MHz, thus providing AGC control from -45 dbm to -95 dbm.

The coherent AGC (Signal type) is a forward type which utilizes a correlation detector to detect the signal, followed by a dc amplifier, whose output is proportional to the transponder carrier signal input, and a single transistor IF amplifier as the controlled element. Since the bandwidth of the correlation loop is approximately the same as the PLL, a S/N ratio of = +13 db for -115 dbm signal level is expected. The coherent AGC provides +15 db of control after the transistor limiter circuit, but before the phase detector. Thus, the carrier signal level into the PLL is held constant independent of the carrier signal levels into the transponder, to below -115 dbm.

### 3.4.2 Noise Figure

The noise figure of the transponder receiver is 9 db or less.

The noise figure of the receiver is given by the relationship:

$$F_T = \frac{T_A}{T_O} + F_1 - 1 + \frac{F_2^{-1}}{G_1} + \frac{F_3^{-1}}{G_1 G_2} + \frac{F_4^{-1}}{G_1 G_2 G_3} + \frac{F_5^{-1}}{G_1 G_2 G_3 G_4} + \frac{F_6^{-1}}{G_1 G_2 G_3 G_4 G_5}$$

where  $F_1$  and  $G_1$  are related to the losses in the preselector,  $F_2$ ,  $F_3$  and  $G_2$ ,  $G_3$  are the noise figures and gains of the RF stages, respectively.  $F_4$  is the noise figure of the 2-pole filter,  $F_5$  is the mixer noise figure,  $F_6$  is the IF noise figure, and  $G_5$  is the mixer insertion loss.  $T_A$  is the antenna temperature and  $T_O$  is 300° Kelvin. Figure 17 is a block diagram of the receiver front end.

The selectivity of the preselector is kept at the minimum level required to prevent desensitivation of the RF amplifier. This is done to reduce its insertion loss. An eight-pole filter is used since a bandwidth of 18 MHz and an average 65 db rejection of the 449 MHz signals is required. A grounded base amplifier is used as a first and second RF amplifier. Additional RF selectivity requirements are placed in the collector of the RF amplifiers where its effect on noise figure is minimal.

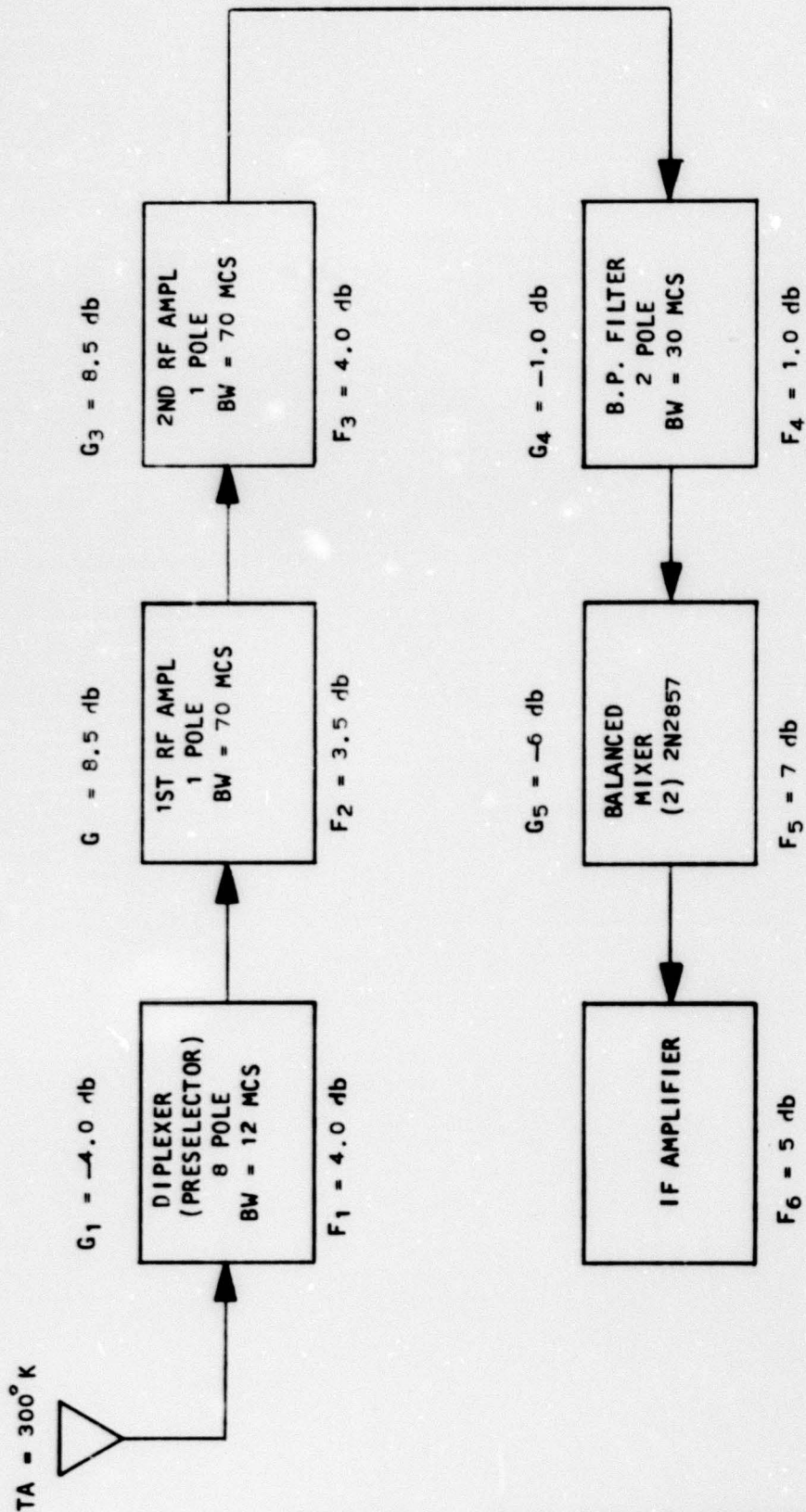

Figure 17

MULTI-ALTITUDE TRANSPONDER RECEIVER  
 RF NOISE FIGURE BLOCK DIAGRAM

The values of the parameters are:

$$T_A = 300^{\circ}\text{K}$$

$$T_O = 300^{\circ}\text{K}$$

$$F_1 = 4.0 \text{ db} = 2.5$$

$$G_1 = 0.4$$

$$G_2 = 8.5 \text{ db} = 7.2$$

$$G_3 = 8.5 \text{ db} = 7.2$$

$$F_3 = 4.0 \text{ db} = 2.5$$

$$F_2 = 3.5 \text{ db} = 2.2$$

$$G_4 = -1.0 \text{ db} = 0.82$$

$$G_5 = -6 \text{ db} = .25$$

$$F_4 = 1.0 \text{ db} = 1.2$$

$$F_5 = 7.0 \text{ db} = 5$$

$$F_6 = 5 \text{ db} = 3.2$$

$$F_T = \frac{300}{300} + 2.5 - 1 + \frac{2.2 - 1}{0.4} + \frac{2.5 - 1}{(0.4)(7.2)} + \frac{1.2 - 1}{(.4)(7.2)^2} + \frac{5 - 1}{(0.4)(7.2)^2(0.82)} + \frac{3.2 - 1}{(0.4)(7.2)^2(0.82)(0.25)}$$

$$F_T = 2.5 + 3.0 + 0.52 + 0.01 + 0.25 + 0.55 = 6.83 \text{ or } 8.4 \text{ db}$$

Note that the primary contributions to the overall noise figure are the pre-selector and the first RF stage. As previously mentioned, the preselector loss is 4 db due to the number of poles and the difficult diplexing problem. Without the preselector, the receiver overall noise figure would reduce to 4.4 db, or well within the original 6 db specification. Note that the design of all circuits,

as far down as the IF strip, exhibit excellent noise performance denoting the care which was taken to provide the minimum noise figure consistent with other specification requirements.

### 3.4.3 Phase Stability

The phase delay imparted to any ranging or timing subcarrier in the presence of any combination of subcarriers as defined in paragraph 3.1.1 and at individual modulation index as defined in 3.3.12, does not change from the phase referenced at a -75 dbm signal input to the transponder receiver, over the dynamic range of -45 dbm to -115 dbm by more than that shown below.

(NOTE: Also referenced to room temperature.)

<u>Temperature Range</u>	<u>Phase Stability Over Dynamic Range</u>
Minus 4 <sup>0</sup> F to Plus 160 <sup>0</sup> F	2.5 degrees maximum
Plus 23 <sup>0</sup> F to Plus 113 <sup>0</sup> F	0.75 degrees maximum
Plus 32 <sup>0</sup> F to Plus 95 <sup>0</sup> F	0.5 degrees maximum

Once set at -45 dbm and -115 dbm, the phase delay imparted to any sub-carrier, under the conditions as defined above, remains constant within 0.5 degree for periods up to 45 minutes. Hysteresis effects are constant to within 0.5 degree for both the conditions of start-up/shut-down and changes of input signal over the dynamic range. The above holds true for incoming signals having AM components up to 35 percent.

The phase stability systems analysis was thoroughly covered in paragraph 3.1.3. The basic circuit design technique is to develop a good open loop transponder to ensure excellent closed loop stability. For all circuit designs, consistent with other specifications, the phase delay stability is of primary importance. Circuits are generally of broadband design to reduce their absolute phase delay. The primary factor, that is the crystal filters, are, as mentioned previously, carefully chosen. The ranging and timing crystal filter bandwidths are

kept at the widest bandwidth possible, to reduce their phase slope, consistent with the S/N restrictions.

Circuitry in the feedback loop is minimized to a single 2-pole cavity filter to reduce the effects of feedback delay changes on output phase shift.

Circuitry outside the PFFB loop is kept as wide as possible, again to reduce absolute delay times.

In general, for most of the circuit design, a large power mismatch was purposely incorporated into the design to reduce the effects of active component parameter shifts on the circuit transfer function. Thus, for example, the Q of a tuned circuit was determined by a discrete loading resistor rather than the input-output impedance of the associated active devices.

In referencing the original specification 3.4.3, it is interesting to point out that as written, the only phase variations of interest are those over dynamic range -45 to -115 dbm, referenced to -75 dbm, at various temperatures within the temperature range specified. This, we are sure, is not the intent of the customer and thus, it is suggested that a reference temperature be stated.

Example:

Original Specification -  $\pm 3^{\circ}$  Maximum for dynamic range -45 to -145 dbm  
referenced to -75 dbm at any temperature  $-4^{\circ}\text{F}$   
to  $+160^{\circ}\text{F}$

Modified Specification -  $\pm 3^{\circ}$  Maximum for dynamic range and temperature  
specified referenced to -75 dbm at room  
temperature

The phase stabilities originally specified can be changed to those indicated above, namely

$\pm 3^\circ$  Maximum to  $2.5^\circ$  Total

$\pm 1.5^\circ$  Maximum to  $0.75^\circ$  Total

$\pm 1.0^\circ$  Maximum to  $0.5^\circ$  Total

Also hysteresis from  $1^\circ$  to  $0.5^\circ$ , and time  $1^\circ$  to  $0.5^\circ$ . The above changes are practical since the design of the transponder is such as to allow strict control of the phase stabilities with temperature and dynamic range beyond the original specification limits. For an analysis of the additional system accuracy which this allows, refer to Section IV.

Some additional causes of phase delay variations not previously mentioned are:

- Amplitude modulation in the transmitter output at the subcarrier frequencies. This AM can be caused by the phase modulation process and by PM-to-AM conversion in the transmitter amplifiers. The amount of AM is reduced by using broadband transmitter amplifiers, careful design of the phase modulator, and by limiting in the receiver and in the transmitter chain.
- The PFFB loop will not compensate for variations in time delay brought about by the AM components fed back in the loop. Further, the AM is magnified by the reduction of the PM as a result of the feedback.
- Spurious signals in the local oscillator path. Balanced mixing is incorporated to reduce feedback of spurious signals at the receiver frequencies from the LO path.
- Leakage LO paths. The design of the diplexer and resultant RF selectivity keep this leakage down to at least -30 db.

#### 3.4.4 Select Call Sensitivity

The "select call" circuit positively engages at levels of -115 dbm or less at the selected frequency. "Positively engage" is interpreted to mean continuous operation without interruption. The above holds true for incoming signals having AM components up to 35%.

The original specification modification was discussed in paragraph 3.3.9. Note that for the initial select call operation, only the "select call" subcarrier, in combination with say a command subcarrier, should be transmitted by the ground station. Once the initial select call operation is accomplished, all combinations of composite input signals and modulation levels can be used simultaneously to keep the transponder in the "transmit" condition.

#### 3.4.6 Transmitter Modulation

The transmitter employs phase modulation techniques. The modulation index of each subcarrier re-transmitted at the 449.00 MHz carrier lies within the range of 0.5 to 2.5 radians, and the re-transmitted modulation index for each subcarrier is the same -3 to -23% as each incoming subcarrier signal modulation index. The modulation index of each subcarrier re-transmitted at the 224.500 MHz carrier lies within the range of 0.25 to 1.25 radians and the re-transmitted modulation index for each subcarrier is one-half of that re-transmitted at 449 MHz. This shall hold true for any combination of incoming signals as defined in 3.1.1 whose modulation indexes for each subcarrier are within the limits of 0.5 to 2.5 radians. The above shall hold true for incoming signals having AM components up to 35%.

Since the 224.5 MHz transmitted signal is derived from the same multiplier chain as the 449 MHz transmitted signal, then the modulation index of each transmitted subcarrier at 224.5 equals one-half of that transmitted at 449 MHz.

The original specification stated that the modulation index at the transponder transmitter output has to be within  $\pm 10\%$  of that received. What is the theoretical best that can be done using a PFFB type of transponder?

$$m_o = m_i - \frac{m_i}{1 + K\mu\beta}$$

where

$m_o$  = output index

$m_i$  = input index

$K\mu\beta$  = system loop gain

$$\frac{m_i}{1 + K\mu\beta} = \text{IF index}$$

for

$$K\mu\beta = 30$$

$$m_o = m_i - \frac{m_i}{31}$$

$$m_o = m_i \left(1 - \frac{1}{31}\right) = m_i \quad (.968)$$

therefore, the output modulation index is 96.8% of the input modulation index, at its theoretical best. Allowing the same variation of 20% as the original specification, we have

$$m_o = \left. \begin{array}{l} -3\% \\ -23\% \end{array} \right\} m_i$$

#### 3.4.6 Transmitter Output Spurious Suppression

The spurious emission at the transmitter is in accordance with paragraph 3.5.2 of MIL-I-11748B, as amended.

Transmitter spurious is reduced primarily by the post filter at the 224.5 and 449 MHz output. Since the transmitted carriers are derived from a fundamental 18.7 MHz oscillator, the multiplication up to the output frequencies is obtained in small steps rather than a single jump. This is done in order to filter the fundamental to guarantee the output rejection specifications of  $\geq 60$  db for all harmonically related spurious. 18.7 MHz is first multiplied by 4 to 75 MHz. A four-pole filter at 75 MHz rejects 18.7 MHz by 50 db minimum. A times three multiplier yields 224.5 MHz followed by a times 2 for the 449 MHz. Four poles at 224.5 reject the 75 MHz by  $> 70$  db (two of these poles are the 224.5 MHz post filter). Thus the 18.7 MHz spurious is rejected an additional 24 db above and beyond the 50 db obtained by the 75 MHz filter.

The 8 pole 449 MHz post filter rejects 75 MHz  $> 100$  db while the 18.7 MHz spurious is rejected by  $> 50$  db above and beyond that obtained by the filtering at 75 MHz.

#### 3.4.7 Receiver Spurious Response

The response of the transponder receiver to spurious signals is down at least 60 db. This includes response to image frequencies, intermediate frequencies and unwanted signals generated within the receiver. The above holds true for incoming signals having AM components up to 35%.

The image frequency is  $= 2 \text{ IF} + \text{RF} = 2 (28 \text{ MHz}) + 421 \text{ MHz} = 477 \text{ MHz}$ . The 8-pole preselector provides 100 db of image rejection without considering the other poles provided by the preamplifier circuitry. Rejection of unwanted signals received through the transponder antenna is excellent due to this 8-pole

preselector, the use of double conversion, and the use of selective IF amplifiers rather than wideband RC or DC coupled amplifiers **having good gain characteristics** at the IF frequency.

Frequencies generated within the transponder are confined by extensive line filtering between modules, and individual circuits. In addition, all oscillators within the transponder are RF shielded by enclosures and use shielded coax cable to deliver their outputs.

#### 3.4.8 Amplitude Modulation Suppression

The transponder receiver provides sufficient limiting to suppress all AM components on the receiver carrier to less than 5 percent as measured at the output of the receiver detector with any combination of input signals as defined in paragraph 3.1.1. The output of the transponder transmitter has no AM components of more than 5%. The above holds true with signals at the receiver input having AM components up to 35%.

Some of the most severe problems encountered in a phase-following system are those resulting from the presence of amplitude modulation components on the received signal, or the generation of such components internal to the transponder. Since the phase detector is sensitive to amplitude variations, these amplitude modulation signals are faithfully reproduced and transmitted to the frequency modulator where they are introduced into the frequency following loop as FM signals. The transponder now attempts to make a frequency modulation correction to an amplitude modulation signal, with the result that these undesired AM effects create distortion and are re-transmitted to the ground station as a part of the FM composite signal. Since these amplitude modulation products are not desired, the MATS transponder use three separate circuit functions to eliminate them. The AM either transmitted or inherently generated is reduced by (1) a limiter in the receiver, (2) a limiter in the transmitter and (3) the receiver

AGC system. The receiver and transmitter limiters reduce the AM by suppression of all composite signal amplitudes to a fixed value. Thus, the output amplitude is relatively independent of the input amplitude variations and represents a constant output power level.

The receiver non-coherent AGC can follow AM signals whose frequency response is  $< 10$  KHz. Since the AM transmitted by the ground station occurs primarily at 286 Hz then the non-coherent AGC reduces this AM commensurate with its feedback gain. Refer to Figure 18 for non-coherent AGC time response.

The coherent AGC will also react, in a similar manner, to the low frequency AM resulting from the residual AM fed to the receiver correlation detector. Refer to Figure 19 for coherent AGC time response.

Note that when the ground transmitter has AM on its carrier, the effective carrier power is reduced when compared to the same signal level without AM. For 35% sine wave AM the average carrier power reduction is approximately 2 db. This should be considered as an additional factor when calculating the MATS transponder receiver sensitivities since they are measured with 35% AM at the receiver input.

#### 3.4.9 Data Transit

The rise time of any combination of composite data signal, as defined in paragraph 3.1.1, when pulsed on and off at an 80 PPS or less rate with a 10 plus 1 minus zero millisecond "carrier on" duty cycle at the transponder receiver input, does not exceed 1 millisecond or have an overshoot of more than 5% as measured at the output of the receiver detector (filtered output). The fall time of the composite data, under the same conditions, does not overlap any succeeding pulse by more than one millisecond. Undershoot does not exceed 5%.

The data transit time is controlled primarily by the 3 db bandwidth of the PFFB loop. The bandwidth is

NOT REPRODUCIBLE

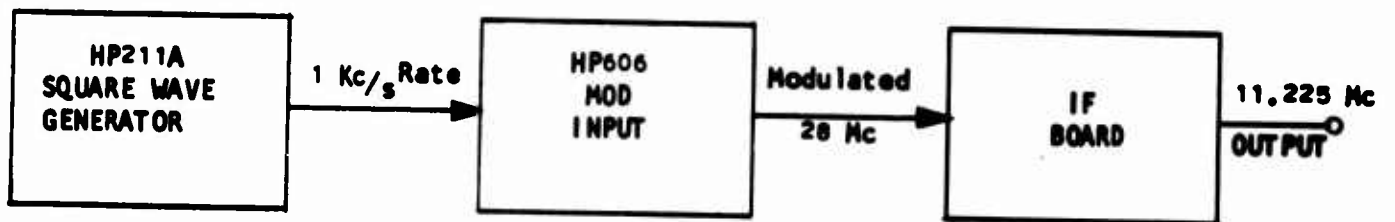

Fig. 18 AGC Time Response (Noncoherent Loop)

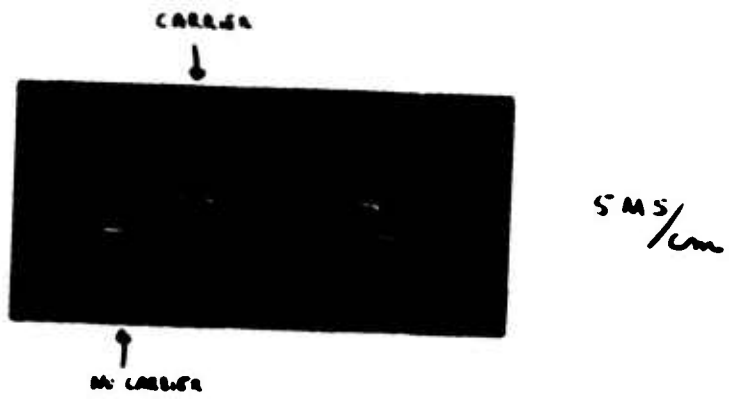

Figure 19 Coherent AGC, Dynamics

$$Bw = (3 \text{ db crystal filter bandwidth}) \times \text{PFFB ratio}$$

$$3 \text{ db}$$

$$= 100 \text{ cps} \times 30 = 3 \text{ KHz}$$

$$t_r = \frac{0.35}{Bw \frac{3db}{2}} = \text{rise time (10 - 90\%)} \text{ for a step input}$$

$$t_r = \frac{.35}{1.5 \text{ KHz}} = .234 \text{ MS}$$

Refer to Figure 20 for actual measured times. Note that the noise output, without a subcarrier, was measured since the dynamics required of a subcarrier for the above test is not conveniently obtained.

Since the loop is, if anything, overdamped, overshoot problems are minimized.

#### 3.4.10 Frequency

The output frequency of the transponder transmitter is 224.500 MHz and 449.000 MHz. The accuracies and stabilities of the 449 and 224.5 MHz output are  $\pm 0.001\%$  or better over the worst environmental conditions defined in this purchase description.

The frequency accuracy and stabilities of the transponder transmitter frequencies are determined by the 18.7 MHz oscillator from which the output frequencies are derived. The oscillator is preset by a trimmer capacitor to within  $\pm 1$  Hz of the desired output frequencies 224.500 MHz and 449.000 MHz (when multiplied by 12 to 224.5 and by 24 to 449 MHz). The stability of the oscillator is specified to better than  $\pm 0.001\%$  over the worst environmental conditions as specified in the purchase description.

#### **3.4.11 Ranging Sensitivity**

The ranging sensitivity of the transponder is at least -115 dbm. Ranging sensitivity is defined as that signal level at the receiver input, with any combination of the modulation subcarriers defined in paragraph 3.1.1, at which each of the ranging or timing subcarriers, as defined in subparagraphs a, b, c, d, e or f of paragraph 3.1.1 has a signal to noise ratio of at least 6 db at the input to the transmitter modulator.

Much has already been said relative to the above in paragraph 3.3.12. The main point that should be made here is that the value of signal to noise ratio which can be easily measured must be manipulated to approach the above 6 db figure. Therefore, it is recommended that the above specification be rewritten to encompass the result of the actual measured value.

Re-write to: "Ranging sensitivity is defined as that signal level at the receiver input, with one ranging or timing subcarrier at a modulated index of 2.4 radians which produces a signal to noise ratio of at least 12 db at the input to the transmitter modulator."

#### **3.4.12 Transmitter Carrier Signal to Noise Ratio**

The transponder transmitter carriers (449.000 MHz and 224.500 MHz) in the 1.5, 2.5 and 3.5 watt configuration, have a signal to noise ratio of at least 40 db. The above holds true when the transmitter output has been modulated by each of the subcarriers defined in subparagraphs a, b, c, d and e of paragraph 3.1.1 at the level defined in paragraph 3.4.5.

There has been a long misunderstood specification, the objective of which is to guarantee that the transmitted output of the transponder does not degrade that S/N ratio presented by the receiver to the modulator. This is easily guaranteed by providing a carrier to noise ratio of at least 40 db at the output.

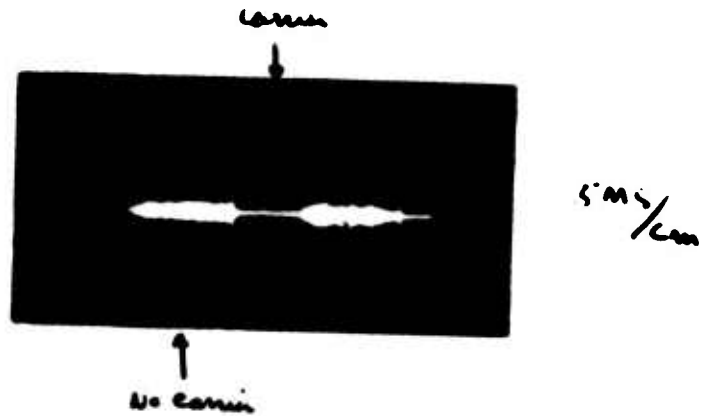

Figure 20 PFFB Loop Dynamics

Another test would be to compare the S/N output of the transmitter with that presented to the modulator input.

The S/N ratio of the transmitter alone is calculated in Appendix B and results in a minimum S/N of 60 db.

**SECTION IV**  
**TRANSPONDER PERFORMANCE**

#### IVA. TRANSPONDER PERFORMANCE

MATS breadboard tests were performed with GIMRADA representatives in attendance between August 1 and August 9, 1966. The results of these tests are noted below with comments related to each test. Applicable paragraphs in the contract specification and breadboard test procedure are noted relative to each test.

##### 6.1.4 BB Test Procedure

##### 3.3.7 Spec

Title: Standby Power

<u>Temperature</u>	<u>Volt</u>	<u>Current</u>	<u>Power</u>
Room	14.5V	86 ma	1.24 w
Room	17.5V	72	1.26
+158°F	17.5	73.5	1.29
-4 °F	17.5	76	1.33

Comments: The standby power required by the original contract specification is 1.0 watt maximum. The maximum above is 1.33 watts. As noted in the design section, unless shortcuts such as (1) abandonment of worst case design, (2) PLL acquisition detection without using correlation, (3) stage starvation and (4) reduced design margins are taken, the prospect for reduced standby power is poor.

It is recommended that the contract specification be modified to approximately the above power levels since they represent the best effort possible consistent with good design practice.

6.2 BBTP

3.4.10 Spec.

Title: Frequency Accuracy and Stability

NOTE: Frequency measured only at 449 MHz output since 449 MHz is harmonically derived from 224.5 MHz.

<u>Temp.</u>	<u>Freq. Stab.</u>	<u>Freq. Stop</u>	<u>Freq. High</u>	<u>Freq. Low</u>
Rm	448,995,803	448,999,215	448,999,667	448,995,803
+158 <sup>o</sup> F	448,999,148	448,999,716	448,999,716	448,999,146
-4 <sup>o</sup> F	448,999,320	448,999,672	448,999,779	448,999,305

Comments: Spec is ±.001% which is easily met.

6.1.10 BBTP

3.3.7 Spec.

Title Operate Power 4.5 watt Mode.

Rm	17.5	2.4 amp	42
+158 <sup>o</sup> F	17.5	2.55 amp	44.6
-4 <sup>o</sup> F	17.5	2.1	36.8(Output power limited)

Comments: The maximum operate power required by the original contract specification is 39.0 watts. The maximum above is 44.6 watts. This is as expected (refer to Design section III). The results above represent a best design effort consistent with all other parameters of the original contract specification. It is recommended that the contract specification be modified to approximately the above values since they represent the best effort possible consistent with the given design parameters and the present state-of-the-art in power supply efficiency, diplexer insertion

loss, and available HF power transistors. These parameters are the primary factors determining the amount of input power used to provide a given output power.

6.3 BBTP

3.4.2 Spec

Title: Receiver Noise Figure - 11.25 db

Comments: The automatic noise figure measurement using an HP343 NF meter, although a valid parameter test for subchassis buyoff, does not supply a correct answer to the noise performance of our transponder receiver. The noise figure measurement takeoff point in the transponder contains high level 39 MHz, derived from the VCO, causing an error in measurement. In addition, other factors such as limiting, create a non-gaussian noise distribution to further confuse the noise measurement.

Both of the above factors tend to yield a higher than normal noise figure reading. The NF should not be measured directly but should be a calculated result based upon the receiver sensitivity measurements. Using the above criteria, we find that the actual NF of the receiver as calculated from data obtained in paragraph 3.4.11 Section IV is

$$F = -KT - S - B_N - S/N + M_I - AM$$

where

$$KT = -174 \text{ dbm/cps}$$

$$S = 115 \text{ dbm}$$

$$B_N = 100 \text{ cps} \times Q \times \text{PFFB} \times n$$

Q = Noise bandwidth correction factor - 2 or 6 db

PFFB = 30

n = Number of crystal filters (3 db bandwidth = 100 cps each)

$B_N = 36 \text{ KHz/S}$  or 45 db

S/N = +12 db minimum measured value

$M_I = +8 \text{ db}$

AM = 35% AM signal reduction factor = 2 db

F = +174 - 115 - 45 - 12 + 8 - 2

F = 8 db

This figure corresponds to that which would be expected from the design calculations in Paragraph 3.4.2 of design section III. In any case, we cannot supply a transponder with a noise figure of less than 8 db, since the diplexer loss is 4.0 db. The original specification is 6 db max. It is recommended that the contract specification be modified to encompass those values of NF which can be reasonably expected.

#### 6.4 BBTP

##### 3.3.10 Spec

Title: RF Power Output

Only 4.5W mode checked because transponder must be torn apart for other modes.  
(Breadboard on ly)

Temp.	224.5 Power	449 Power
Rm	4.05 W	3.5 W
+158 <sup>o</sup> F	4.05	2.95
-4 <sup>o</sup> F	3.4	3.0

Note: The output power at -4°F apparently limited at the above levels. That is, increased drive produced no output power increase.

Comments: As mentioned in the design section, one cannot reasonably expect to provide 4.5 watts at the output of each transmitter terminal with the present power input limitations, the high insertion loss corresponding to a diplexed 8-pole post filter at 449 MHz, the transponder size limitations, etc. It is, therefore, recommended that the purchase specification be modified to values commensurate with the above.

The above levels, relative to the input powers noted in BBTP 6.1.10 are the result of state-of-the-art transmitter, power supply and diplexer designs.

6.5 BBTP

3.3.11 Spec

Title: Receiver VSWR

Frequency	VSWR
412 MHz	1.14
416	1.37
421	2.60
426	1.89
430	1.43

Comments: The original specification is  $\leq 1.5$  VSWR over the bandpass of interest. Referring to the design section paragraph 3.3.11, it is noted that best receiver noise figure does not necessarily occur at power match. Therefore, it is recommended that the VSWR specification be relaxed since the optimum receiver performance occurs at a VSWR  $\neq 1.0$ .

6.6 BBTP

3.3.11 Spec.

Title: Transmitter VSWR

Frequency	VSWR
449 MHz	1.25
224.5 MHz	1.26

Comments: Transmitter VSWR is not measured at other frequencies since the final amp is tuned to the center frequency. At "off" center frequencies a reactive load might be presented to the output transistor causing over dissipation in the transistor. Spec is  $\leq 1.5$  VSWR.

6.7 BBTP

3.4.6 Spec

Title: Transmitter Spurious

No spurious noted from 449 MHz output.

224.5 Spurious

at  $+158^{\circ}\text{F}$ , Spurious at C. F.  $+75$  MHz 6.3 db down (4th har. of 18.6 MHz)

at  $-4^{\circ}\text{F}$ , Spurious at C. F.,  $\pm 18.6$  MHz 60 db down.

Note: Spurious noted on 449 MHz output but generated by Spectrum Analyzer mixer input when levels approaching 1 mw are used for inputs.

Comments: Spec calls out all harmonically related spurious shall be  $\geq 60$  db down from fundamental; all non-harmonically related spurious shall be  $\geq 80$  db. The 449 MHz output is clean. The 224.5 MHz output contains harmonic spurious generated by the 18.7 MHz

carrier oscillator from which the output frequencies are derived.

The specification is met as written.

6.8 BBTP

3.4.7 Spec

Title: Receiver Spurious

Receiver spurious was checked by examining the output of the 28 MHz IF with the spectrum analyzer while the H-P 608 generator (at a level of -45 dbm, or greater) was swept through its frequency range 10 MHz to 480 MHz. An IF output at an unwanted input frequency was regarded as a spurious output.

No spurious signals were noted other than at frequencies which had harmonics at 421 MHz.

Comments: Specification requires spurious to be  $\geq 60$  db down from desired carrier. The specification is met as written.

7.1 BBTP

3.4.8 Spec

Title: AM Suppression

The phase station was set up to 35% AM by comparing its 421 MHz output signal to the signal of an HP 608 AM'd to 35% at 400 Hz, on the spectrum analyzer.

The outputs of the receiver IF and transmitter were observed on the spectrum analyzer. At all 3 temperatures, the AM was much less than 5%.

The demodulated received signal and the demodulated retransmitted signal were observed on scopes. Both had about 5% A.M. on each of

the individual subcarriers at the various temperatures. The spec is met as written.

7.2 BBTP

3.4.5 Spec.

Title: Modulation Index Capability

The Modulation Index Capability was checked by setting each subcarrier to a modulation index of 2.4 radian. The demodulated output of the transponder was observed on a scope monitoring the wideband demodulator output of the phase station. The peak output on the scope should increase linearly with the peak modulation of the subcarriers.

Temp.	Number of Subcarriers					% Difference
	1	2	3	4	5	
Rm	1.0 cm	2.0	2.9	3.8	4.7	-6%
-4°F	1.0 cm	2.0	2.7	3.4	4.1	-18%
-158°F	1.0 cm	2.0	2.8	3.8	4.4	-12%
at M.I - 0.5 Rad 1 tone						
Rm	1.0 cm	2.0	3.0	4.0	4.9	-2%

Comments: The original specification requires the modulation index at the transponder 449 MHz output to be within  $\pm 10\%$  of the input modulation index to the transponder receiver input. Since a closed loop transponder can never have a modulation index at its output greater than at its input, the  $+10\%$  part of the specification is meaningless. For a FFFB ratio of 30:1 the output index must be  $-3\%$  of the input, assuming theoretical operation.

It is recommended that the original specification be modified to allow for practical variations in the transponder output modulation index.

7.3 BBTP

3.44 Spec

Title: Acquisition and Select Call Sensitivities

Temp.	Acq. Sens.	S. C. Sens	
		M. I. = .25 rad	M. I. = .5
Rm	-125 dbm	-119	-120
+158°F	-119	-119	-118
-4°F	-119		-116

Comments: Spec requires -115 dbm or less. The spec is met whether a .25 or .5 radian subcarrier index is used.

7.5 BBTP

3.3.15 Spec

Title: Transponder Warmup/Shutdown

Transponder warmup practically instantaneous.

Transponder shutdown

Temp.	Time cw	Time pulsed
Rm	15 sec	14 sec
+158°F	22	23
-4°F	12	

Comments: Since the transponder is completely solid state, and as a result of the tests above, the transponder warmup times can be reduced to 6 seconds. This, in effect, allows the transponder to use more input power during transmit than originally specified in the contract specification, for a given net energy input (i. e., watt-hours/day).

The turnoff performance was unsatisfactory since P. S. turnoff did not function at all and manual turnoff indicated shutdown times were too long. Appropriate action is being taken to ensure that the prototypes meet the specification.

It is recommended that the warmup time be shortened to reduce the total amount of energy used by the transponder.

7.8 BBTP

3.4.3 Spec

Title: Phase Stability

Sub	Ref	-45	-65	-85	-105	-110	-113		
Mod Index = 2.4, all subcarriers									
1	69.8	0 <sup>0</sup>	0	+ .1	+ .5	+ .3	+ .3		
2	91.0	0	0	0	+ .2	+ .2	0		
3	68.4	0	0	0	0	0	0		
5	77.2	0	0	0	0	0	0		
6	63.8	0	0	0	- .1	- .1	- .1		
Mod Index - .5									
1	80.4	0 <sup>0</sup>	- .4	- .4	- .4	- .3	- .3	- .3	
2	94.5	0	- .5	- .4	- .4	- .4	- .4	- .4	
3	75.6	0	- .7	- .8	- .5	0.5	- .7	- .7	
5	80.3	0	- .7	- .7	- .7	- .7	- .7	- .7	
6	68.8	0	- .5	- .6	- .2	- .7	- .7	- .7	

Phase Shift vs. Dynamic Range

Ref -45 dbm

Room Temperature

Phase did not change over 45 min period in Subcarrier 1

Sub	Frequency	hys. (on-off-on)					
1	585 KHz	+.1 <sup>0</sup>					
2	549	0					
3	583	0					
5	565	0					
6	588	0					
4	548	-					
Temp.	Sub.	-45	-65	-85	-105	-110	-113
Rm.	1	0	0	0	+ .1	0	0
+158 <sup>0</sup> F		- .3	- .3	- .3	- .3	- .3	-
- 4 <sup>0</sup> F		-1.3	-1.3	-1.3	-1.6	- .6	-
Rm	2	0	0	0	0	0	0
158 <sup>0</sup> F		- .7	- .9	- .9	- .9	- .9	-
-4 <sup>0</sup> F		-1.4	-1.4	-1.4	-1.6	-2.0	-
Rm	3	0	0	0	0	0	0
158 <sup>0</sup> F		+ .1	+ .1	+ .1	+ .1	+ .1	-
-4 <sup>0</sup> F		- .9	- .9	- .9	-1.2	-1.2	-
Rm	5	0	0	0	0	0	0
158 <sup>0</sup> F		- .4	- .6	- .6	- .6	- .6	-
-4 <sup>0</sup> F		- .6	- .6	- .6	- .6	- .9	-
Rm	6	0	0	- .1	- .1	- .1	- .1
158 <sup>0</sup> F		-1.6	-1.6	-1.7	-1.7	-1.7	-
-4 <sup>0</sup> F		- .6	- .6	- .6	- .6	- .6	-

**Phase Shift Ref. Rm. Temp -45 dbm**

**M. I. - 2.4 Rad.**

**Comments: Refer to Figure 1 for a plot of above data. The specification is**

<b>-40°F to +160°F</b>	<b>· 3° Max.</b>	
<b>-23°F to +113°F</b>	<b>· 1.5° Max.</b>	
<b>-32°F to + 95°F</b>	<b>· 1° Max.</b>	<b>Over dynamic range -45 to -115 dbm</b>
<b>time</b>	<b>1° Max.</b>	
<b>hysteresis</b>	<b>1° Max.</b>	

**In ALL cases the spec is met with large margins.**

**Referring to Section IVB, one should note that a reduction in phase change of the transponder is a direct function of the performance capabilities of a DME system. The data above indicates the superior phase stability performance of the MATS transponder in relation to the design specification. This is a direct result of the care taken by ITT in the design to ensure excellent performance in what is considered a primary, if not "the" primary design parameter of the transponder. This design philosophy, having produced better than required phase stability, necessitated conservative design practice in areas which, if phase stability was considered less, may have satisfied what are felt to be less important parameters.**

**It is felt that the phase stability performance as represented by the BB test data, can be easily repeated by the prototype. This allows the purchase specification to be changed so that the customer can expect less phase stability error than was originally reasonable to expect. The advantage being an increased DME system accuracy.**

KOE 10 X 10 TO 1/4 INCH 46 1323  
 7 X 10 INCHES  
 KEUPPEL & ESSER CO.

FIG I

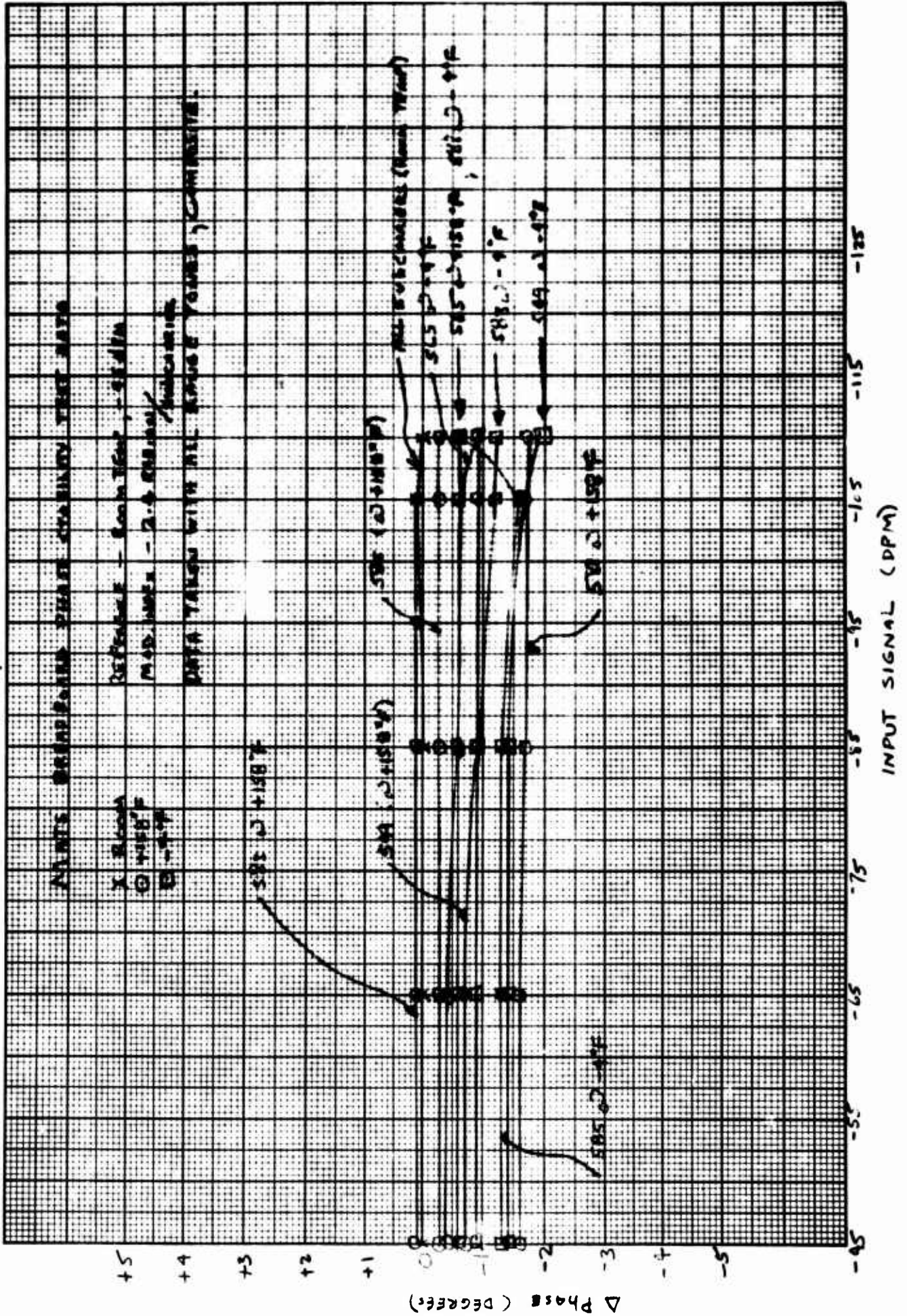

7.9, 7.10 BBTP

3.4.11 Spec.

Title: Ranging Sensitivity

The input was set to -115 dbm and the signal-to-noise ratio of 1 subcarrier at a modulation index of 2.4 radians was measured using a true RMS reading voltmeter.

Temp.	S/N
Rm	13.6 db
158 <sup>o</sup> F	14.7
-4 <sup>o</sup> F	12

The original specification requires a S/N ratio of at least +6 db for all combinations of subcarriers and modulation indexes.

Since the measurement of all combinations is not readily measurable, the above test was substituted. The worst S/N ratio of +12 db above can be calculated as follows:

$$S/N = -KT - S - B_N - F + M_I - AM$$

where

$$KT = -174 \text{ dbm/Hz}$$

$$S = 115 \text{ dbm}$$

$$B_N = 100 \text{ Hz} \times Q \times \text{PFFB} \times n$$

$$Q = \text{conversion factor from 3 db to noise bandwidth} = 2$$

$$\text{PFFB} = 30$$

$$n = \text{number of crystals within PFFB loop} = 6$$

$$B_N = 100 \times 2 \times 30 \times 6 = 30 \text{ KHz or 45 db}$$

$$F = 8 \text{ db}$$

$$M_I = 8 \text{ db}$$

$$AM = 75\% \text{ AM signal reduction factor} = 2 \text{ db}$$

$$S/N = +174 - 115 - 45 - 8 + 8 - 2$$

$$S/N = +12 \text{ db}$$

Relating the above to that required by the original specification, we have

$$M_I = 0.5 \text{ radians or } -6 \text{ db, (worst case combination one sub-carrier only)}$$

$$B_M = 100 \text{ cps} \times Q \times n \times \text{PFFB} = 100 \times 2 \times 1 \times 30 = 6 \text{ KHz or } 37 \text{ db}$$

where

$n = 1$  since we will consider only that bandwidth associated with each subcarrier.

(Note: This is not a measurable value.)

then

$$\begin{aligned} S/N &= +174 - 115 - 37 - 8 + (-6) - 2 \\ &= +6 \text{ db} \end{aligned}$$

Thus the intent of the specification is met.

It is recommended that the specification be modified to encompass a test which can be related to direct measurement, rather than a calculated sensitivity value.

7.10 BBTP

3.4.12 Spec

Title: Transmitter Carrier Signal to Noise Ratio

Signal Noise out of transmitter - S N out of receiver.

The specification is ambiguous and, therefore, the above test was substituted.

This test assures that the transmitter does not contribute noise to that already present at the receiver output (i. e., modulator input).

It is recommended that the specification be rewritten to encompass the above test.

7.11 BBTP

Title: Doppler Shift

Temp. Shift

Rm No shift

$-15^{\circ}\text{F}$   $1^{\circ}$  from  $-18$  kHz to  $+22$  kHz

$-4^{\circ}\text{F}$   $.3^{\circ}$  from 0  $+15$  kHz,  $+1.0$   $+20$  kHz,  $+2.9$   $22.5$  kHz  
 $-2^{\circ}$  from 0  $-22$  kHz

Comments: No applicable specification. Results were quite favorable although one would expect no appreciable phase shift in the transponder as a function of carrier frequency shift.

8.1

3.3.16.1

Title: Thermal Sensors Continuity

Temp (Amb.)	Transmitter	P. S.	Demod.
Rm	1050	1100	1100
+158°F	380	380	380
-4°F	13.5k	12k	11k

Comments: None. Spec met.

8.2 BBTP

3.3.16.2 Spec

Title Signal Strength Monitor

Temp.	-45	-55	-65	-75	-85	-95	-105	-115
Rm	1.7v	1.71	1.9	2.25	2.75	3.38	3.75	3.85
158°F	2.21	2.25	2.43	2.90	3.62	4.40	4.60	4.60
-4°F	1.1	1.2	1.35	1.5	1.8	2.15	2.4	2.4

Comments: See Figure II. Specification requires (1) approximately logarithmic, (2) resolution  $\pm 2$  db, (3) overall accuracy  $\pm 5$  db for one year. Figure II shows extremely poor temperature characteristics. Corrective measures are to be taken to ensure that curve shifts with temperature are minimized. The non-coherent AGC covers the range -45 to -95 dbm. The curve shape is approximately logarithmic, but the resolution in the -45 to -55 db area is worse than 2 db. The curve is a function of the reverse AGC characteristics of the IF amplifiers. As expected, the high level input represents near cutoff performance.

K<sub>0</sub>E 167015 INCH 46 1323  
PROPERTY ESSEN...

F-111

MATS BB  
SIGNAL STRENGTH MONITOR

X ROOM

○ +15.5°F

□ -4°F

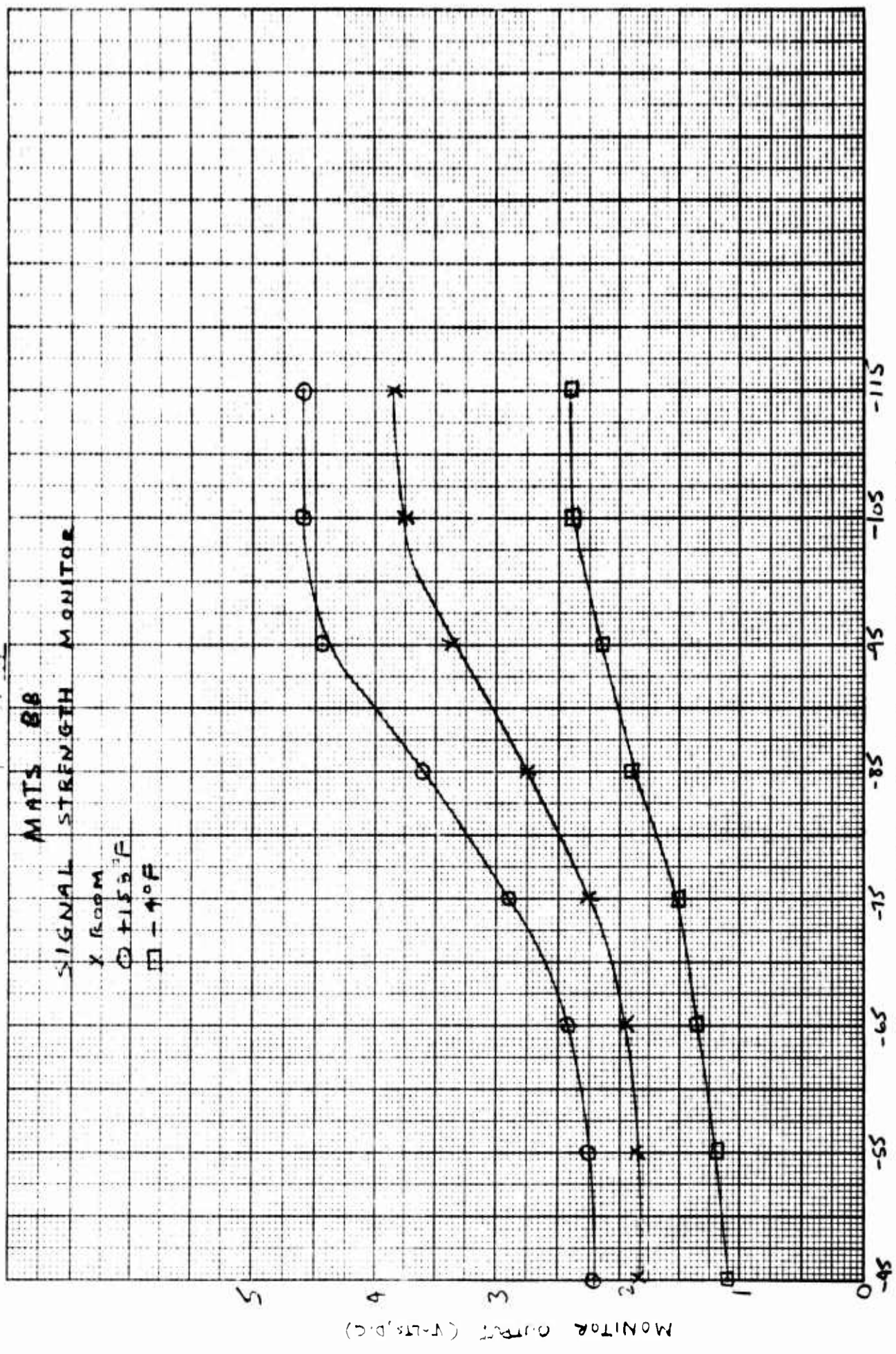

INPUT SIGNAL STRENGTH (dbm)

MONITOR OUTPUT (WATTS, D.C.)

It is recommended that the specification be modified (1) to define the curve function as other than approximately logarithmic, (2) to reduce the resolution specification between -45 to -55 dbm to  $\pm 5$  db, (3) to cover the -45 to -95 dbm range monitoring the non-coherent AGC circuits, and (4) to cover the -95 to -115 dbm range monitoring the coherent AGC circuits.

8.3 BBTP

3.3.16.3 Spec

Title: Power Output Monitor

Rm. Temp.		158 <sup>o</sup> F		-4 <sup>o</sup> F	
P. O.	Volt	P. O.	Volt	P. O.	Volt
2.9	3.4	1.95	3.0	2.8	2.9
1.7	2.8	2.3	3.2	1.45	1.9
2.2	3.15	2.75	3.3	2.4	2.7
0.4	0.9	0.25	1.0	0.4	0.7
1.0	2.1	1.4	2.6	1.6	2.15

Comments: Refer to Figure III.

It is not possible, using simple RF detector circuitry, to obtain the required 5% linearity specification.

It is recommended that the specification be changed consistent with Figure III.

K&E 10 X 10 TO 1/2 INCH 46 1323  
7 X 10 INCHES MADE U.S.A.  
KEUFFEL & ESSER CO.

MATS B.B.  
POWER OUTPUT MONITOR  
FIG III

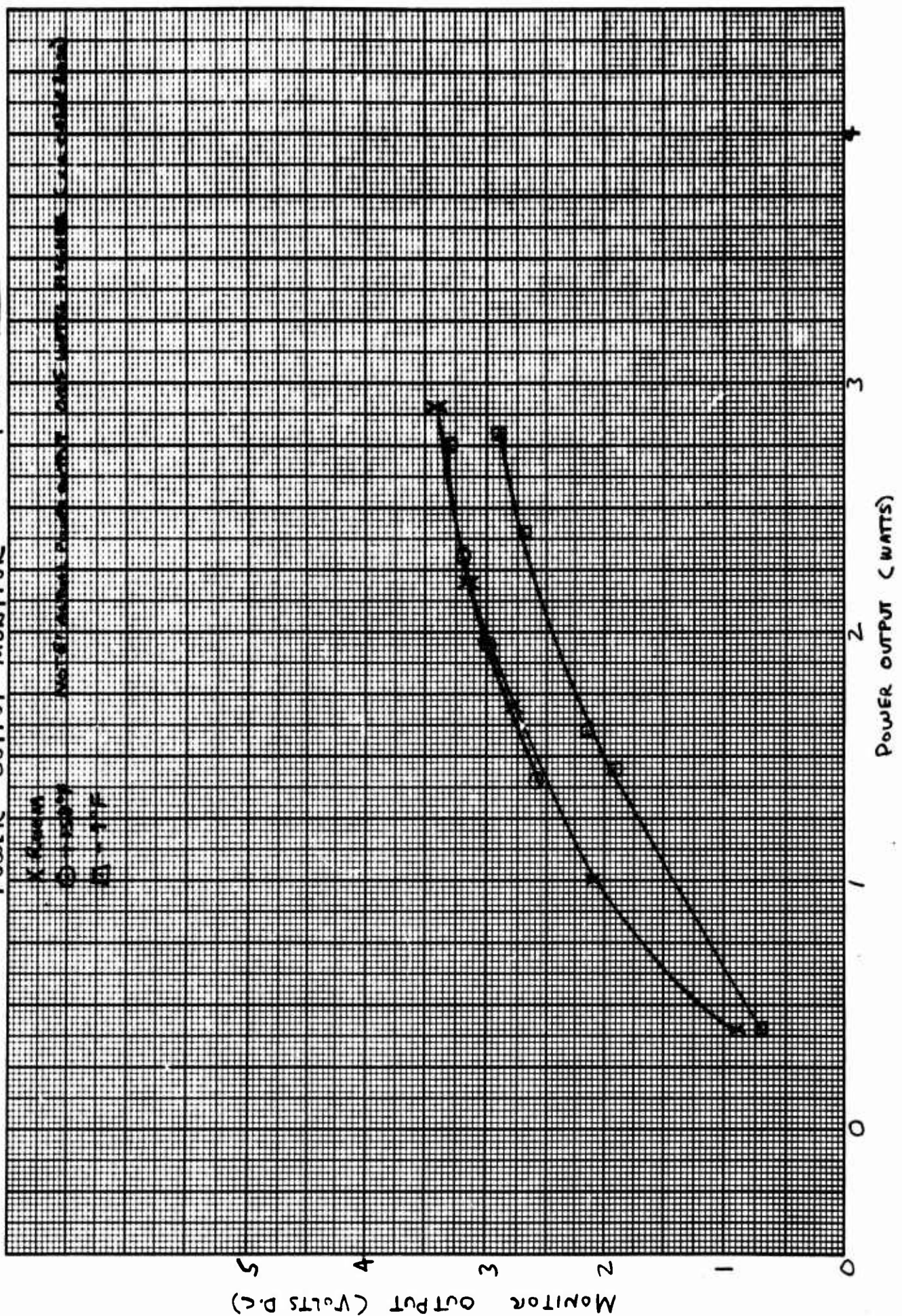

8.4 BBTP

3.3.16.5 Spec

Title: Acquisition Output Monitor

Level	Rm	+158°F	-4°F
-125 dbm	4.8v	4.65	5.0
120	4.8	4.65	5.0
115	3.95	4.45	5.0
110	3.44	3.85	4.45
105	2.98	3.50	3.05
100	2.42	3.05	2.7
95	1.82	2.45	2.5
90	-	2.00	2.4
85	1.68	1.75	2.35
80	-	1.70	2.35
75	1.68	1.68	2.3

Comments: Refer to Figure IV.

The coherent AGC function is represented along with the acquisition indication. The useful range of the curve for signal strength is -95 dbm to -115 dbm. The initial movement of the output voltage off of the static reference voltage indicates initial acquisition. The above performance meets the specification.

KOE 10 X 10 TO 1/2 INCH 46 1323  
7 X 10 INCH  
HEUFFEL & ESSEN CO.

MAT: BB

ACQUISITION OUTPUT MONITOR

FIG IV

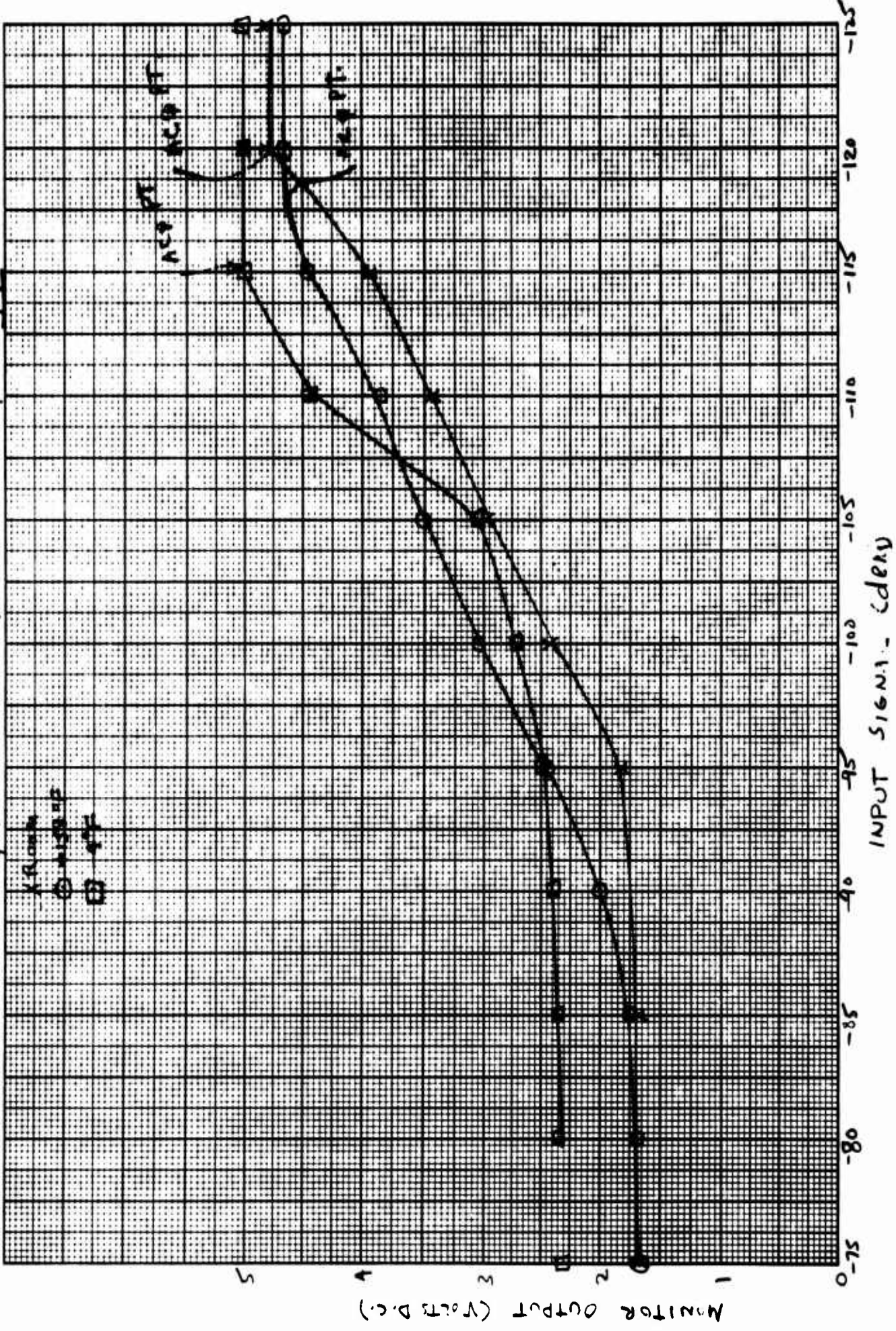

8.5 BBTP

3.3.16.5 Spec

Title: Automatic Phase Monitor

Deviation from c. f.	Rm. temp.	+158°F	-4°F
+22.5 kHz	3.52V	3.4	3.8
+15	3.13	3.05	3.4
+ 7.5	2.70	2.6	3.0
0	2.23	2.1	2.5
- 7.5	1.70	1.6	2.0
+15	1.13	1.05	1.5
-22.5	0.55		
-18		0.85	1.25

Comments: Refer to Figure V. Meets spec.

8.6, 8.7

3.3.19

Title: Command Frequency Outputs

Temp.	C <sub>1</sub>		C <sub>2</sub>	
	.25	.5	.25	.5
Rm	16 db	16.5	16 db	16.5
158°F	17	18	17	18
-4°F	16.25	17.5	15	16

Comments: Spec requires +19 S/N ratio and 1.5 V Rms min. Output at -115 dbm input. The S/N spec will be easily met on the prototypes at index 0.5 radians. The breadboard amplifiers are limiting unnecessarily.

KOE 10 X 10 TO 1/4 INCH 48 1323  
7.8 10 INCHES MADE IN U.S.A.  
KEUFFEL & ESSER CO.

MATS 8B

FIG 5

AUTOMATIC PHASE MONITOR

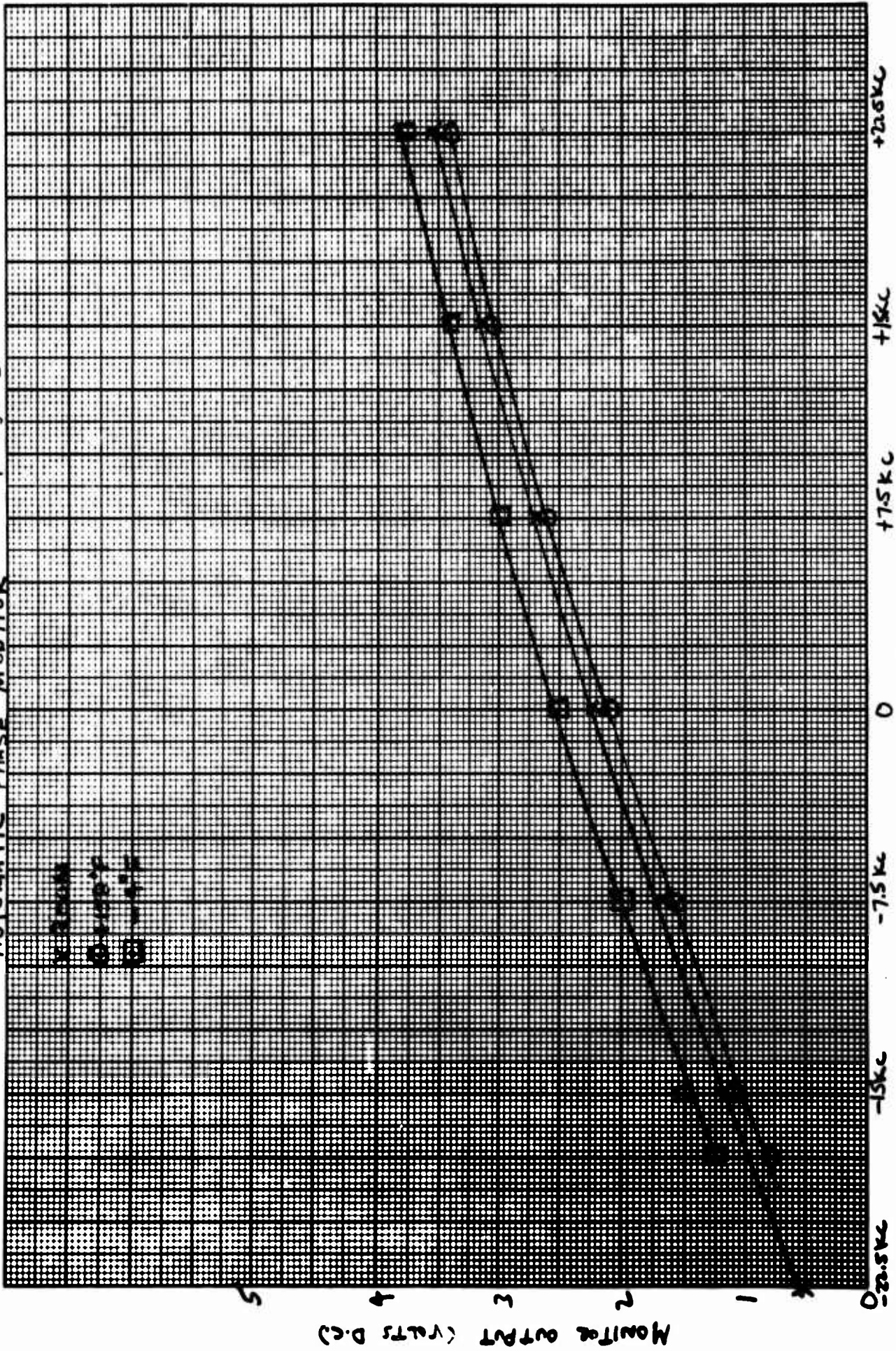

MONITOR OUTPUT (VOLTS D.C.)

FREQUENCY DEVIATION (Kc/s)

**S/N = +25 db with 0.5 radian index (No AM Correction)  
Expected on  
prototypes**

**Rms measured output  $\approx$  1.5v Rms - Suggest lowering output to 1V  
Rms maximum, if possible.**

IVB.      **TRANSPONDER PERFORMANCE. THE MATS AND THE SECOR  
DME SYSTEM**

1.0      Range Accuracy

The following section is concerned with the impact upon ranging accuracy of transponder power output and bias errors. A comparison is made of the trade-off between 3.0 watt versus 4.5 watt outputs as related to the existing reduction of allowable range errors due to temperature, time and hysteresis.

2.0      Power Output

The first determination to be made is whether a reduction in power output from 4.5 to 3.0 watts would create a threshold problem in locking the frequency following ground receiver loop. The power budget is listed below for the worst case situation of a 2,500 mile path.

Power out 4.5 watts:	37 dbm
Ground antenna gain:	<u>18 db</u>
Total power at receiver:	+55 dbm
KT factor:	-174 dbm
Noise figure (ground):	6 db
Phase following bandwidth (2,400 cps):	34 db
Desired S/N at threshold:	6 db
Path loss	<u>159 db</u>
	31 dbm

With a 4.5 watt output, the down link threshold margin is 55-31 or 24 db. A 3.0 watt output will reduce the margin by 2 db down to 22 db. The above is for the high frequency link. The low frequency link is 5 db poorer because of reduced antenna gain on the ground. In either case, sufficient margin exists to indicate no threshold problem at maximum range.

Range is determined by measuring phase delays of various subcarrier frequencies. The critical measurement is at the highest frequency of 585.530 kHz. It can be shown that to a first order, the mean squared phase jitter<sup>2</sup>, is:\*

$$\sigma^2 = \frac{1}{2} \frac{N}{S}, \text{ where } \frac{N}{S} \text{ is the rms noise to signal ratio}$$

in the bandwidth of interest.

The rms phase error is proportional then to the  $\sqrt{N/S}$ . Consequently, the increased error due to noise for the 3.0 watt transmission will be the  $\frac{4.5}{3.0}$ , or 1.22 times as much for the 3.0 watt transmission.

The absolute error, however, is still quite small in magnitude. Assuming a 1 cps bandwidth for the ranging subcarrier, a 4.5 watt output and a unity noise improvement modulation factor, the S/N ratio at the output will be 64 db for the maximum range case previously calculated. For this case,

$$\sigma^2 = \frac{1}{2} \frac{N}{S} = \frac{1}{2} 0.4 \times 10^{-6} = 0.2 \times 10^{-6} \text{ (radians)}^2$$

$$\sigma_{\text{rms}} = 0.45 \times 10^{-3} \text{ radians}$$

For the highest frequency subcarrier, the wavelength is 512 meters. The above rms phase jitter represents an error of 0.037 meters. For the 3.0 watt output, the error increases to 0.045 meters.

Several factors should be realized in determining what influence this increased error has on system accuracy. Position determination of an unknown station is made by a statistical analysis of many data points. The number shown

---

\* NOTE: Frazier and Page, "Phase Lock Loop Frequency Acquisition Study,"  
IRE Trans. Space Electronics and Telemetry, Sept. 1962.

above is the deviation from the mean for each individual range measurement. For a total of  $n$  measurements, the deviation is reduced by  $\sqrt{n}$ , and becomes considerably smaller. All other things being equal, this smaller error would still be 1.22 larger for a 3.0 watt versus 4.5 watt situation. It is felt, however, that in either case, the error caused by noise would be negligible. This is borne out by the fact that a 0.945 meter error cannot even be detected by the electronic range servo, which has a resolution of 0.25 meters (more than five times as large as the calculated error). It is evident, therefore, that within the limits of the present system configuration, a reduction of transponder power from 4.5 to 3.0 watts will not noticeably affect the end result.

### 3.0 Bias Errors

The original specification allows for bias errors as follows:

Temperature:	$\pm 3^\circ$ (subcarrier phase)
Time:	$1^\circ$ total
Hysteresis:	$1^\circ$ total

The final tested unit has a maximum overall temperature drift of  $2.5^\circ$ , and no discernible time or hysteresis errors. Assuming a uniform distribution for each error, the rms error per specification can be  $1.78^\circ$ . The rms error of the tested unit is  $0.725^\circ$  or 2.45 times smaller. At the highest subcarrier frequency, this represents a reduction in bias error from 2.5 meters to 1.0 meter. Note that this type of error cannot be reduced by repeated measurement as was the statistically distributed noise error, because the bias offset becomes the new mean value of the statistical set. Consequently, the reduction in bias error afforded by the transponder over existing specifications far outweighs the negligible contribution to the noise error created by a reduced power output. The trade-off per measurement represents a net gain to the system of approximately 1.5 meters in range accuracy.

#### 4.0 Refraction Correction

The prior analysis holds as well for the lower frequency refraction correction link. This link is 5 db poorer than the high frequency link. Therefore, the range error due to reducing output power will increase from 0.066 meters to 0.08 meters. As before, this error is still well within the resolution capability of the range servo. The improvement in bias error from 2.5 meters to 1.0 meter applies in exactly the same way as before. Consequently, the net improvement per measurement is also approximately 1.5 meters for the low frequency down link. The refraction correction will, as a result, have an improved accuracy of the same order.

In conclusion, the more desirable DME system is one in which the bias error is kept as small as possible. Power output reduction will not adversely affect the range measurements as long as a threshold problem within the ground receiver does not exist.

SECTION V

CONCLUSION

MODIFIED SPECIFICATION

V      CONCLUSION - MODIFIED SPECIFICATION

This section contains a modified specification which reflects the anticipated performance of the prototype units. The specification is supported by the design considerations discussed in this report and by the performance of the breadboard system. This specification may be referenced directly to the existing purchase description by paragraph numbers.

### 3. REQUIREMENTS

#### 3.1 Description

The multi-altitude SECOR transponder shall be designed to be a compact, lightweight, efficient transponder for use in Satellite configurations. The transponder shall consist of a receiver and transmitter for accepting ranging, timing and command information from a station located on a ground complex and retransmitting the ranging and timing information on two off-set carriers back to the ground complex. In addition, certain telemetry circuits shall be provided within the transponder in order that conditions concerning the transponder may be telemetered back to the ground station, by telemetry systems external to the transponder.

##### 3.1.1 Composite Signal

The composite signal from the ground complex shall consist of a carrier whose nominal frequency is 420.9375 mc phase modulated by any combination of fixed frequency subcarriers as follows:

<u>Subcarrier Frequency</u>	<u>Description</u>
a. 585.553 KC	Subcarrier referenced at ground station complex and used to measure range.
b. 583.246 KC	Same as a.
c. 549.223 KC	Same as a.
d. 548.937 KC	Same as a.
e. 565.000 KC	Subcarrier used to establish system timing.
f. Subcarrier in the range of 500-600 KC	Subcarrier used as a Satellite ranging function.

<u>Subcarrier Frequency</u>	<u>Description</u>
g. Subcarrier in the range of 500-600 KC	Subcarrier used as a Satellite command function.
h. Subcarrier in the range of 500-600 KC	Same as g.
i. Subcarrier in the range of 400.00 KC to 600.00 KC	Subcarrier known as "Select-call" and used to command the transponder from a "receive" to a "transmit" condition.

The modulation index of each individual ranging subcarrier will be within the range of 0.5 to 2.5 radians. The modulation index of individual command subcarriers and the select call subcarrier will not exceed 0.5 radians. The composite index can be any index that might result from any combination of ranging subcarriers, one command subcarrier and the select call subcarrier modulated within these ranges.

Of the above received subcarriers, only those shown in a. through f. are to be purposely modulated on the transmitter carrier for retransmission to the ground complex.

### 3.1.2 Transmitter

The nominal frequency of the two (2) offset transmitter frequencies shall be 449.000 mc and 224.500 mc. The transmitter section of the transponder shall be designed to provide nominal outputs of either 1.5, 2.5 or 3.5 (selectable) watts at the transmitter antenna terminal for each of the two (2) transmission frequencies of the transmitter.

### 3.1.3 Phase Shift

The SECOR System is a phase measuring system and as such the transponder shall impart minor phase shift to the incoming ranging subcarriers

wide ranges of signal input and conditions of environment as referenced in paragraph 3.4.3.

#### 3.1.4 Solid State Components

The transponder shall be designed using only solid state components, preferably silicon.

#### 3.2 Materials

All materials used in the transponder shall be of such substance as not to deteriorate in the environment (vacuum, radiation, vibration and heat) to which the transponder will normally be subjected and defined in other paragraphs of this document. Any questionable materials shall be tested within the expected environment prior to inclusion within the final design.

#### 3.3 Design

##### 3.3.1 General

The transponder shall be designed for a useful life of at least one year's normal operation. The transponder shall be used in satellite configurations in orbits up to 2500 nautical miles at inclinations from 0 to 90 degrees.

The transponder shall be designed to operate in a "standby", "receive" or "transmit" condition. In the "standby" condition (minimum power mode) only those circuits necessary to place the transponder in a "receive" condition upon receipt of a coherent carrier are required. In a "receive" condition those circuits required to provide access to the select call and other normal command signals, shall be engaged. In the "transmit" condition all circuits shall be energized and the transponder shall be capable of performing in a manner called out in other paragraphs of this document.

**3.3.2 Weight**

The weight of the transponder including the outer housing, interconnecting cables, connectors and hardware required for proper performance, shall not exceed 12 pounds.

**3.3.3 Size and Shape**

The overall dimensions of the transponder, including mounting brackets, connectors, and hardware, required for proper performance shall not exceed 276 cubic inches for either one of the desired configuration of 1.5, 2.5 or 3.5 watts of output power. The transponder shall be housed in one (1) regular figured rectangular package. The outside dimensions, including mounting bracketing, connectors and any other hardware required for proper performance shall not exceed 4-1/4" x 6-1/2" x 8-1/2".

**3.3.4 Dissimilar Metals**

Dissimilar metals shall not be used in intimate contact unless protected against electrolytic corrosion. Dissimilar metal combinations and comparable metal coupling shall be as defined in MIL-STD-33586.

**3.3.5 Connectors**

The use of connectors shall be minimized to the highest degree practical. Where connectors are required, they shall be keyed or positioned so that mating errors cannot be made. All connectors, once mated, shall be capable of being locked in place either by screw or other positive technique.

**3.3.6 Environment**

**3.3.6.1 Thermal Vacuum**

The transponder shall perform within the limits called out in paragraph 3.4 in thermal environments from minus 4 degrees F to plus 160 degrees F in

vacuums of at least  $1 \times 10^{-5}$  mm of mercury. In addition, the transponder shall be capable of being stored in a vacuum of  $1 \times 10^{-5}$  mm of mercury at a temperature of minus 30 degrees F without damage to the transponder. Once removed, the transponder shall be capable of performing within the limits called out in paragraph 3.4.

### 3.3.6.2 Vibration

The transponder shall perform within the limits called out in paragraph 3.4 after being subjected to the following types and levels of vibration.

#### a. Sinusoidal Vibration (all major perpendicular axes)

<u>Frequency (cps)</u>	<u>Applied Vibration Level (zero to peak acceleration)</u>
5 - 14	0.5 in. DA
14 - 40	±5.0 g
40 - 50	±7.5 g
50 - 70	±30 g
70 - 2000	±22.0 g
2000 - 3000	±20.0 g

#### b. Random Vibration (all major perpendicular axes)

<u>Frequency (cps)</u>	<u>Applied Vibration Level (g<sup>2</sup>/cps)</u>
5 - 14	0.07 g <sup>2</sup> /cps
15 - 50	0.10 g <sup>2</sup> /cps
50 - 200	0.40 g <sup>2</sup> /cps
200 - 2000	0.20 g <sup>2</sup> /cps

### 3.3.6.3 Shock

The transponder shall perform within the limits called out in paragraph 3.4 after being subjected to three half-sine wave shock impulses of 0.5 milliseconds duration at a level of 200 gs in each major perpendicular axis.

#### **3.3.6.4 Acceleration**

The transponder shall perform within the limits called out in paragraph 3.4 after being subjected to sustained acceleration forces of at least 22 g for periods of at least 15 minutes in all major perpendicular axes.

#### **3.3.6.5 Irradiation**

The transponder shall be designed to perform within the limits called out in paragraph 3.4 for at least one year when subjected to radiation environments expected to be encountered for the worst type orbit (both elliptical and circular) as defined in paragraph 3.3. A study shall be carried out to establish the worst radiation conditions which will be encountered. As a result of the study, the following parameters shall be established:

- a. Integrated ionization dose
- b. Maximum ionization dose
- c. Integrated proton flux
- d. Maximum proton flux
- e. Integrated electron flux
- f. Maximum electron flux

All known sources and their contribution to the environment, including sun activity, shall be used. For purposes of study, it shall be assumed that:

- a. No additional high altitude nuclear blast will take place.
- b. The units will be launched in time frame from 1965 and 1970.
- c. The only other material which will be shielding the transponder (satellite skin) will be an aluminum alloy cover, type 6061-0, 0.05 inches thick.

As a result of this study, a test plan for component selection criteria (as regards to irradiation properties) and for the testing of the transponder shall be

formulated. All assumptions, study and test plans and component selection criteria shall be forwarded to the Contracting Officer for approval.

3.3.7 Primary Power Requirements

The transponder shall perform within the limits called out in paragraph 3.4 when subjected to input voltage variations from 11.5 to 17.5 VDC. The input power requirements of the transponder shall not exceed those listed below, for the mode shown, with 17.5 volts DC applied at its primary power input.

Standby Mode	<sup>0.9</sup> <del>2.5</del> watts maximum
<del>Receive Mode</del> 1.5 watt output mode	<sup>WATTS</sup> " " 25.0 watts maximum
2.5 watt output mode	37.5 watts maximum
3.5 watt output mode	46.0 watts maximum

3.3.8 Radio Frequency Interference

The transponder shall meet the requirements of Class I equipment as defined in MIL-I-11748B, Amend. 2.

3.3.9 "Select Call" Circuit

Circuitry shall be provided within the transponder to recognize whether or not a "select call" signal is present and carry out the operation required to place the transponder in a "transmit" condition. The circuit shall be capable of being readily changed and fixed (by minor tuning and/or crystal insertion, etc.) to recognize a given subcarrier within the range of 400 to 600 KC. The bandpass of the circuitry associated with the "select call" frequency shall be designed so that the -45 dbm to -115 dbm or other spurious transponder signals shall not falsely trigger the transponder in a "normal" operate condition. The above shall hold true for all worst combinations of environment and voltage variations called out within this document. Provisions shall be made to override the "select call" circuit from an external switching function without having to

insert a "select call" signal at the receiver input. The connections for the override feature shall terminate at an easily accessible point or an external connector. Should mechanical switching, such as a relay, be required for placing the transponder in a "transmit" condition, no surge or normal current load shall exceed the rated current carrying capacity of the contacts.

#### 3.3.10 Transmitter Output

The transponder shall be capable of providing either 1.5, 2.5 or 3.5 watts output from the transmitter terminals, which shall include the diplexer, on both 224.500 mc and 449.000 mc. Choice of the desired output shall necessitate only the replacement of a component and require only minor additional tuning and calibration. Minor tuning and calibration is defined as the process required by a technician not thoroughly familiar with the transponder, but by reading instructions, to tune and calibrate the transponder in a two (2) hour period using standard laboratory equipment for normal operation and performance as defined in other paragraphs of this document.

#### 3.3.11 Antenna Input/Output

The transponder shall require, at a maximum, only two (2) antenna connections for reception of signals from the ground complex and transmission of the ranging and timing data back to the ground complex. A diplexer shall be provided as an integral part of the transponder, prior to the antenna output terminations, to allow reception of signals on 420.9375 mc and the transmission of signals on 449.000 mc. All output terminals, including the diplexer, shall be capable of handling either the 1.5, 2.5 or 3.5 watt output configurations. The insertion loss of the diplexer shall be no greater than 2.5 db (includes the post filter).

The input/output impedance of all antenna connections shall be 50 ohms over the total bandwidth of interest. The transmitter VSWR shall not exceed

1.5 at center frequency. The VSWR of the receiver shall be consistent with optimum receiver sensitivity.

### 3.3.12 Bandpass

The overall bandpass of the transponder and data channels (including all subcarrier commands) shall be designed to minimize phase shift as defined in paragraph 3.4.3 while considering all system instabilities, any combination of modulation index, S/N, the effects of doppler and all other requirements defined in this document. For purposes of design, some of the system considerations are: (1) the maximum radial velocity of the satellite, which contains the transponder, shall be that associated with the satellite, which contains the transponder, shall be that associated with an elliptical orbit whose perigee is 200 N. miles and whose apogee is 2000 N. miles in altitude;

(2)	<u>Frequency</u>	<u>Stability</u>
a.	420.9375 mc carrier	0.001%
b.	All subcarriers	0.005%

(3) modulation indexes of the individual ranging and tuning subcarriers shall lie within the range of 0.5 to 2.5 radian; (4) the transponder ranging data signal to noise ratio shall be 12 db as defined in paragraph 3.4.11.

### 3.3.13 Grounding

The outer housing or case of the transponder shall be isolated from the primary power system. DC isolation shall be in excess of 1 meg. AC isolation shall be a maximum that is consistent with good RFI design. The outer housing shall be used only as RF ground.

### 3.3.14 External Cables

All external cabling other than that utilizing coax, shall be shielded to the highest degree practical. All shielded cable shall be grounded (RF ground)

at both ends and shall be of low capacitance. No shield shall be used as a common return except for RF. Should more than one package be required, provisions shall be made for a positive electrical RF bond, either in a remote or stacked condition, between all package housing.

#### 3.3.15 Transponder Warm-Up/Shut-Down Properties

The transponder shall be operating and in a condition to perform as defined in paragraph 3.4, under the worst combination of environmental, voltage variation and dynamic range conditions defined in paragraph 3.3.6, 3.3.7 and 3.4.1 respectively, within 6 seconds after the receipt of a "select call" subcarrier or the activation of the "select call" override as defined in paragraph 3.3.9.

The transponder shall remain in the "transmit" condition, under the same conditions defined above, at least 7 seconds, but not more than 15 seconds, after the termination of the "select call" subcarrier or the deactivation of the "select call" override as defined in paragraph 3.3.9. This shall hold true for pulsed "select call" signals where the pulse rate is 20 PPS with carrier on duty cycles of 15 percent or more.

#### 3.3.16 Telemetry Sensors and Outputs

Certain telemetry parameters shall be provided within the transponder in order to obtain housekeeping data while in orbit. The circuits required to provide the parameters shall be integral to the transponder and shall consist of the following.

##### 3.3.16.1 Thermal Sensors

Three (3) thermal sensors shall be placed in the transponder; one (1) shall be placed on the case of the main package; one (1) on a structure in close proximity to the transmitter output; and one (1) on a structure in close proximity to the ranging subcarrier filters and amplifiers. The thermal sensors shall

have a range that will cover the expected temperature within the areas of interest when subjected to the Thermal Vacuum test defined in paragraph 4.3.5. (This does not include non-operating storage conditions.) The thermal sensors shall be of the Fenwal 150-curve type or their equivalent. The sensors shall have a maximum thermal time constant commensurate with overall system consideration. The isolated leads of the thermal sensors shall be brought to an external connector on the transponder for use in an external telemetry system. The thermal sensors shall be passive in that power for these circuits shall not be provided within the transponder but from an external source.

#### 3.3.16.2 Input Signal Strength

Active (powered internal to the transponder) circuits shall be provided within the transponder which shall be used to indicate the received signal strength at the receiver input of the transponder. The output shall be in the range of 0.5 to plus 5 VDC, over the dynamic range of -45 dbm to -95 dbm for non-coherent AGC and -95 to -115 for coherent AGC with external loads of 5,000 ohms or less shunted by 150 micro-micro farads of capacitance. Indications of signal strength shall be available when the receiver is either in the "receive" or "transmit" condition. All circuits required to provide the above output shall be powered internal to the transponder configuration. The output leads shall be routed to an external connector on the transponder for use in external telemetry systems. The presence or absence of the above load shall not damage the transponder or effect its performance as shown in paragraph 3.4 under the worst combination of environment, voltage variation and dynamic range defined within this document. The input strength output shall be approximately logarithmic. At the given temperature, the resolution of the output shall be  $\pm 2$  db (except between -45 to -55 dbm the resolution can be 5 db). The output shall have an overall reading accuracy, including resolution and stability

over the worst combination of environment conditions and dynamic range defined in this Purchase Description of  $\pm 5$  db for a period of one year.

#### 3.3.16.3 Power Output

An active (powered internal to the transponder) circuit shall be provided to indicate the power of the 449.000 mc transmitter output. This circuit shall be capable of providing outputs within a 0 to plus 5 volts DC range for either the 1.5, 2.5 or 3.5 watt output configuration. The output voltage of this circuit versus the output power of the transponder shall be stable and approximately linear to within  $\pm 10\%$  of full scale output reading over all conditions of environment and voltage variations defined in this document.

This circuit shall be capable of driving 5000 ohms shunted in parallel with 150 micro-micro farads. When the transponder is in a "standby" condition, the voltage out of this circuit shall be "0" volts. All circuits and power required to provide the output described above, shall be an integral part of the transponder. The output leads shall be routed to an external connector on the transponder for use in external telemetry systems. The presence or absence of the above load shall not damage the transponder or affect its' performance as called out in paragraph 3.4 under the worst combinations of environment, voltage variation or dynamic range as defined within this document.

#### 3.3.16.4 Other Outputs

Other outputs as deemed important shall be provided for loads as defined above at an external connector.

#### 3.3.16.5 Automatic Phase Control and Frequency Acquisition Voltage

Two outputs, indicative of Automatic Phase Control and of Frequency Acquisition, shall be provided. The output impedance of these circuits shall

be 600 ohms or less. These circuits shall be capable of driving loads of 5,000 ohms or less shunted by 200 microfarads capacitance at levels between 0.5 and 5.0 volts for the output range. Each output shall be plotted for each transponder.

### 3.3.17 Transponder Detector Output

An output shall be provided from the output of the transponder detector or at a point where access may be gained to the composite subcarrier signal as received at the receiver input. This output shall be used to drive command circuits external to the transponder. Access to this circuit shall be available at an external connector. The output impedance of this circuit shall be 600 ohms or less. This circuit shall be capable of driving a load of 5,000 ohms or less shunted by 200 micro-micro farads capacitance at a level of at least 0.5 volts RMS including wideband noise and subcarriers with modulation indexes between .25 to .5 radians. Insertion or removal of a load as defined above shall not damage the transponder or degrade its' performance as called out in paragraph 3.4 under any worst combination of environment, primary voltage variations and dynamic range defined in other paragraphs of this document.

### 3.3.19 Command Frequency Outputs

Two outputs circuits shall be provided within the transponder which shall be used for command signal outputs. These circuits shall operate on subcarriers within the range of 400-600 KC and shall utilize crystal filters in the same manner as the select call circuit. The output impedance of these circuits shall be 600 ohms or less and capable of driving loads of 5000 ohms or less shunted by 150 micro-farads at levels of at least 1.0 volts RMS. Bandwidth of the filter circuits shall be 100 cps and have a S/N improvement of 40 db or a total S/N of at least 19 db with input signal levels of -115 dbm at a modulation index of 0.5 radian.

**3.3.20 Ranging Subcarrier Channel**

An additional crystal subcarrier ranging circuit shall be provided within the transponder to allow for the inclusion of an additional ranging subcarrier in the 500-600 KC range. The bandwidth of the circuit shall be 100 cps and shall be identical to other subcarrier ranging circuits.

**3.3.21 Limiting**

Positive limiting shall be included both in the receiver and transmitter sections of the transponder.

**3.4 Performance**

The transponder shall perform in the manner called out below under the worst combination of environment, primary input voltage variations, and dynamic range as defined in paragraphs 3.3.6, 3.3.7 and 3.4.1 respectively.

**3.4.1 Dynamic Range**

The transponder shall perform and operate properly over input power ranges from -45 dbm to -115 dbm with any combination of fixed frequency subcarriers defined in paragraph 3.1.1.

**3.4.2 Noise Figure**

The noise figure of the transponder receiver shall be 9 db or less. Meeting this requirement does not relieve the contractor of meeting all other performance parameters defined in this document.

**3.4.3 Phase Stability**

The phase delay imparted to any subcarrier, in the presence of any combination of subcarriers as defined in paragraph 3.1.1 and at individual modulation index as defined in 3.3.12, shall not change from the phase referenced at a -75 dbm signal input at room temperature to the transponder receiver, over the dynamic range of -45 dbm to -115 dbm by more than that show below.

<u>Temperature Range</u>	<u>Phase Stability over Dynamic Range</u>
Minus 4 <sup>o</sup> F to Plus 160 <sup>o</sup> F	±0.5 2.5 degrees total
Plus 23 <sup>o</sup> F to Plus 113 <sup>o</sup> F	±0.25 .75 degrees total
Plus 32 <sup>o</sup> F to Plus 95 <sup>o</sup> F	±0.25 0.5 degrees total

One set at -45 dbm and -115 dbm, the phase delay imparted to any sub-carrier, under the conditions as defined above, shall remain constant within 0.5 degree for periods up to 45 minutes. Hysteresis effects shall be constant to within 0.5 degree for both the conditions of start-up/shut-down and changes of input signal over the dynamic range. The above shall hold true for incoming signals having AM components up to 35 percent.

#### 3.4.4 Select Call Sensitivity

The "select call" circuit shall positively engage with an input signal to the transponder receiver, at a level of -115 dbm or less at a 0.25 radian index at the selected subcarrier frequency. "Positively engage" shall be interpreted to mean continuous operation without interruption. The above shall hold true for incoming signals having AM components up to 35%.

#### 3.4.5 Transmitter Modulation

The transmitter shall employ phase modulation techniques. The modulation index of the re-transmitted 449.000 mc signal shall lie within the range of 0.5 to 2.5 radians, and the retransmitted modulation index for each subcarrier shall be the same -3 to -23% as each incoming subcarrier signal modulation index. The modulation index of the retransmitted 224.500 mc signal shall lie within the range of 0.25 to 1.25 radians and the retransmitted modulation index for each subcarrier shall be one-half of that retransmitted at 449 mc. This shall hold true for any combination of incoming signals as defined in 3.1.1 whose modulation indexes for each subcarrier are within the limits of 0.5 to 2.5 radians. The above shall hold true for incoming signals having AM components up to 35%.

#### 3.4.6 Transmitter Output Spurious Suppression

The spurious emission at the transmitter shall be in accordance with paragraph 3.5.2 of MIL-I-11748B, as amended.

#### 3.4.7 Receiver Spurious Response

The response of the transponder receiver to spurious signals shall be down at least 60 db. This shall include response to image frequencies, intermediate frequencies and unwanted signals generated within the receiver. The above shall hold true for incoming signals having AM components up to 35 percent.

#### 3.4.8 Amplitude Modulation Suppression

The transponder receiver shall provide sufficient limiting to suppress all AM components on the receiver carrier to less than 5 percent as measured at the output of the receiver discriminator with any combination of input signals as defined in paragraph 3.1.1. The output of the transponder transmitter shall have no AM components of more than 5%. The above shall hold true with signals at the receiver input having AM components up to 35%.

#### 3.4.9 Data Transit

The rise time of any combination of composite data signal, as defined in paragraph 3.1.1, when pulsed on and off at an 80 PPS or less rate with a 10 plus 1 minus zero millisecond "carrier on" duty cycle at the transponder receiver input, shall not exceed 1 millisecond or have an overshoot of more than 5 percent as measured at the output of the receiver detector. The fall time of the composite data, under the same conditions, shall be such as not to overlap any succeeding pulse by more than one millisecond. Undershoot shall not exceed 5 percent.

#### 3.4.10 Frequency

The output frequency of the transponder transmitter shall be 224.500 mc and 449.000 mc. The accuracies and stabilities of the 449 and 224.5 mc output

shall be plus or minus 0.001% or better over the worst environmental conditions defined in this Purchase Description.

3.4.11 Ranging Sensitivity

The ranging sensitivity of the transponder shall be at least minus 115 dbm. ~~at least minus 115 dbm~~  
Ranging sensitivity is defined as that signal level at the receiver input at which each of the ranging or timing subcarriers as defined in subparagraphs a, b, c, d, or f of paragraph 3.1.1 <sup>at modulation index of 2.4 and</sup> taken one at a time shall have a signal to noise ratio of at least 12 db at the input to the transmitter modulator.

3.4.12 Transmitter Carrier Signal to Noise Ratio

The transponder transmitter carrier's (449.000 mc and 224.500 mc) in the 1.5, 2.5 and 3.5 watt configuration, shall have a carrier to noise ratio of at least 40 db.

**SECTION VI**

**ADDITIONAL INFORMATION**

## 1. THE MATS TRANSPONDER IN THE PRESENT SECOR SYSTEM

"The MATS transponder is compatible with the present Secor system." This statement is fact, but reservations are necessary. It is obvious that all the performance capability of the MATS cannot be obtained using the present system. But what performance should we expect?

### 1.1 The Communications Link Between the Ground Station and the MATS Transponder Satellite

The carrier signal power at the satellite MATS receiver input is calculated

$$S_i = P_R - L_S + G_R + G_T \quad (\text{all in db}) ,$$

where

- $S_i$  = carrier signal power at MATS receiver input
- $P_R$  = power from the Secor ground station = 2000 watts or 63 dbm
- $G_T$  = transmitter antenna gain = + 18 db
- $G_R$  = MATS receiver antenna gain = 0 db
- $L_S$  = free space attenuation loss (2500 nautical miles at 421 MHz)  
= 158 dbm .

Then

$$S_i = 63 - 158 + 0 + 18 = - 77 \text{ dbm} .$$

This is well within the sensitivity of the MATS transponder, which is designed for -115 dbm

The ground station subcarriers can presently be transmitted at modulation indices of up to 0.7 radians per subcarrier. Allowing each of the present four-range, one timing, two command, and one "select call" subcarriers, a modulation index of, say, 0.15 radians, we can expect the following MATS sensitivity performance.

$$\frac{S/N}{\text{Data}} = \frac{S/N'}{\text{Data}} - \left[ S_M - (S_i) \right] - M \quad , \quad (\text{all in db})$$

where  $S/N_{\text{Data}}$  = Signal-to-noise ratio of each ranging or timing subcarrier for present Secor at 2500 NM.

$S/N'$  = Signal-to-noise ratio of MATS measured at 2.4 radians index, -115 dbm (for one crystal bandwidth)  
= +20 db .

$S_M$  = -115 dbm = value at which all minimum sensitivity measurements on MATS were taken

$S_i$  = -77 dbm = minimum carrier power at MATS receiver input from present Secor ground station (2500 n miles)

$M$  =  $\frac{2.4}{0.15}$  = 16 or 24 db = ratio of index at which  $S/N_{\text{Data}}$  was taken, to true index of .15 radians proposed.

By substitution,

$$\begin{aligned} S/N_{\text{Data}} &= 20 - \left[ -115 - (-77) \right] - 24 \\ &= 20 + 38 - 24 = +34 \text{ db} . \end{aligned}$$

Thus, the resultant signal-to-noise ratio of the retransmitted data from the satellite is quite acceptable.

The signal-to-noise ratio for each of the "select call" and command subcarriers is

$$\begin{aligned}
S/N &= -KT - S_i - F - B - M_I && \text{(all in db)} \\
&= 174 - 77 - 9 - 20 - 16 \\
&= +52 \text{ db}
\end{aligned}$$

Thus, the resultant signal-to-noise ratio for each of these commands is quite satisfactory.

Since the peak composite modulation index of all the subcarriers is only  $8 \times 0.15$ , or 1.2 radians, the PFFB loop of the transponder will be somewhat nonlinear, but stable for a step input. Thus, the use of special waveform generating ramp functions is not necessary. "An instantaneous composite subcarrier on-off function is quite acceptable." A maximum 3 db reduction in carrier power can occur while the PFFB is obtaining lock, but this will not affect the carrier loop, since the minimum signal levels are so high.

#### 1.2 The Communications Link Between the Satellite and the Ground Station Receiver

The signal-to-noise ratio in the ground receiver phase following feedback loop is

$$S/N_{\text{Data}} = -KT + P_T - L_S - G_T + G_R - B - F - M_I$$

where

- KT = -174 dbm/HZ
- $P_T$  = 3.0 watts, or 35 dbm
- $L_S$  = 159 db at 2500 n.m. and 449 MHz
- $G_T$  = 0 db = satellite transmitter antenna gain
- $G_R$  = ground receiver antenna gain = 18 db
- B = PFFB loop bandwidth = 2.4 KHz or 34 db
- F = noise figure of ground receiver = 6 db
- $M_I$  = 0.15 radian/subcarrier = 16 db

$$\begin{aligned} S/N_{\text{Data}} &= 174 + 35 - 159 - 0 + 18 - 34 - 6 - 16 \\ &= +12 \text{ db} . \end{aligned}$$

This value is still well above common PFFB loop threshold capabilities.

The carrier S/N ratio in the ground receiver is approximately

$$S/N_{\text{Carrier}} \cong + 28 \text{ db (for a 2.4 KC noise bandwidth) .}$$

### 1.3 Conclusion

From the above analysis, it seems apparent that the MATS transponder and the present Secor system are quite compatible. The performance of the data and carrier channels, in combination with the MATS phase stability, indicate that MATS should provide an excellent phase stable transponder for the present Secor system.

## 2. THE MATS TRANSPONDER WITH A MODIFIED SECOR GROUND STATION

### 2.1 The Ground Transmitter

The power required by the ground station is primarily a function of (1) The minimum acceptable S/N ratio in the MATS transponder; (2) The transmitter antenna gain; (3) The distance between the ground station and the satellite.

For the following parameters we have

S/N	minimum acceptable signal-to-noise ratio at transponder input = 6 db
$L_S$	158 db at 2500 n.m. at 421 MHz
$G_T$	ground transmitter antenna gain = 18 db
$M_I$	minimum index transmitter = 0.5 radian or -6 db.
F	9 db
$B_N$	1000 cps x 2 x PFFB(transponder) = 6 KH or 37 db
$G_R$	0 db

$$\begin{aligned}P_T &= -S/N + KT + B_N + L_S - G_T - G_R + F - M_I \\ &= 6 - 174 + 37 + 158 - 18 - 0 + 9 - (-6) \\ &= 24 \text{ dbm, or 260 milliwatts.}\end{aligned}$$

This results in a very small solid state transmitter. Now, if we want to get rid of the parabolic antenna and replace it with an omnidirectional one, we have

$$P_T = 24 \text{ dbm} + 18 \text{ db} = 42 \text{ dbm, or 16 watts.}$$

Thus, in either case, it is obvious that a much smaller ground station can be used when the MATS transponder is used in a satellite. Note that the MATS transmitter could serve as an excellent ground station transmitter.

The present Secor ground station transmitter bandwidth is much too narrow. All ckts , including the modulator, to the amplifiers and Diplexer, require bandwidths wide enough to provide an over-all bandwidth at the transmitter antenna terminals of  $\geq 15$  mc. This stems from the maximum 2.5 radian index required of each range and timing sub carrier.

The subcarrier signals to the transmitter modulator require circuitry to generate the waveform indicated in Figure 13 of Section III.

## 2.2 The Ground Receiver

The 449 receiver Diplexer and RF amplifier bandwidths need to be increased to  $\geq 15$  MHz, as measured at the input of the first mixer. A modulation ramping function is also required, but it is automatic, since the retransmitted signal from the satellite is a direct copy of that generated by the ground station. Other than the above, the present ground station is probably compatible.

Note that the MATS receiver would satisfy the above criteria and, thus, could easily function as the 449 MHz ground receiver.

The 224.5 MHz receiver requires wider front end bandwidths than presently exist.

## 2.3 Conclusion

The maximum utilization of the MATS transponder would force considerable redesign to the Secor transmitter/modulator and some modification to the ground receivers.

It is suggested that the MATS transponder itself be used as a part of the ground station, since it fulfills most of the redesign criteria.

### 3. MATS TRANSPONDER AND THE PHASE STATION

The phase station used to test the MATS transponder should, at the minimum, have

1. Modulation index capability of 2.5 radian for each of six range or timing subcarriers .
2. Ground simulation equipment for measuring the  $\Delta$  phase of the transponder under dynamic conditions.
3. Phase measuring capabilities better than  $0.1^\circ$ , repeatable.
4. Transmitter and receiver bandwidths compatible with the modulation indices.

Note that the MATS transponder itself can be used as the transmitter and receiver portions of the phase station. When used as part of a measuring device, under laboratory environments, its phase stability is excellent and well within requirements.

#### 4.0 IMPROVEMENT OF TRANSPONDER PHASE SHIFT

It is readily recognized that an important source of error in the accuracy of the SECOR system is the unknown phase shift within the transponder. Phase shift due to temperature and dynamic range can be correlated with those parameters during system test and corrective allowance be made during operational use since temperature and signal strength are TM functions. However, in operational use, there is no means for measuring the change in phase shift that may occur due to aging of components or drift in circuit parameters.

Phase stability specifications for the MATS transponder define the maximum allowable change in phase as  $\pm 3$  degrees over temperature extremes and dynamic range. Although this specification has been met, considerable thought has been given to a method of improving the transponder to an even greater degree of phase stability.

The MATS transponder is a closed loop system by virtue of the frequency compression technique employed. To successfully accomplish frequency compression, it has been necessary to provide a variable phase shift circuit within this loop to permit the operator to adjust for optimum phase match at the first mixer. Once optimized, the phase shift of the circuit is permanently established in the frequency compression loop.

As a result of consideration given to the transponder phase stability, it is believed that by introducing a phase sampling technique within the transponder, the phase stability could be improved by at least one order of magnitude. The phase sampling would provide a detectable phase error which would, when amplified and applied to existing phase shift circuitry, provide a correction to that circuit. This circuitry could be developed and added to the existing MATS transponder at a minimum cost in weight and power. An alternate approach would be that of not correcting the phase shift in the transponder but rather to measure the phase error and to provide the ground station with this information via the TM link.

A block diagram is attached to show the proposed method of accomplishing phase error correction. A 585 Kc signal has been chosen to correspond to the frequency of the fine ranging subcarrier, since phase error is most critical at this frequency. This signal would be injected into the transponder compression loop following the Gain and Phase Amplifier. The path of this injected test signal, through the transponder back to the input of the Gain and Phase Amplifier, will include all of the circuits within the frequency compression loop that are used for normal reception and retransmission of a ranging signal. Sampling of the test signal would be accomplished at the input to the Gain and Phase Amplifier circuit.

The injection signal and the sampled signal would be compared in a phase detector. The resultant error voltage, proportional to phase error, would be applied to the Gain and Phase Amplifier to readjust the phase control circuit for a zero output from the phase detector.

It is possible that this corrective test function could either be superimposed on the normal operational content of the transponder or the test could be accomplished during the periods between interrogation by the ground stations. Under no condition is it anticipated that this test would interfere with the normal transponder functions in the SECOR program.

It is proposed that GIMRADA evaluate the improved overall system operational performance which could be accomplished with one order of magnitude improvement in phase stability and give consideration to the development and subsequent incorporation of such circuitry in one of the MATS prototype transponders.

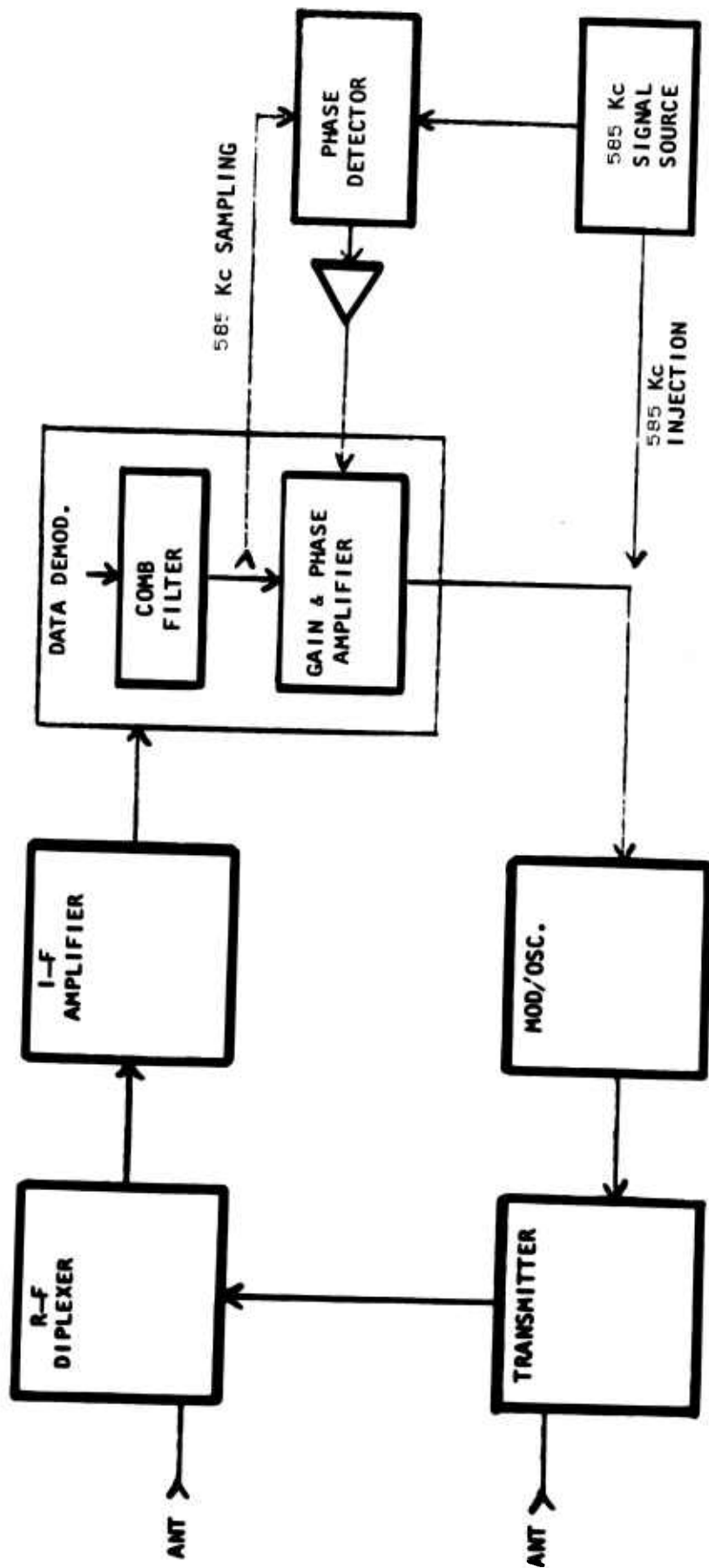

BLOCK DIAGRAM OF  
MATS PHASE ERROR IMPROVEMENT

APPENDIX A

THE POST FILTER PROBLEM

APPENDIX A

THE POST FILTER PROBLEM

At first, it became obvious that the choice of a post filter should be made on rejection of spurious (spec's MIL-11746) and minimum of poles to do this, so that output (post) filter would present a minimum loss to the 449 mc spectrum.

It then became obvious, from diplexing tests, that some of the 449 mc modulation spectrum was entering the receiver bandpass spectrum about 421 mc. Thus, the choice of the post filter should not be made on a spurious criteria, but on the amount of noise being generated by the transmitter, in the receiver acceptance band,

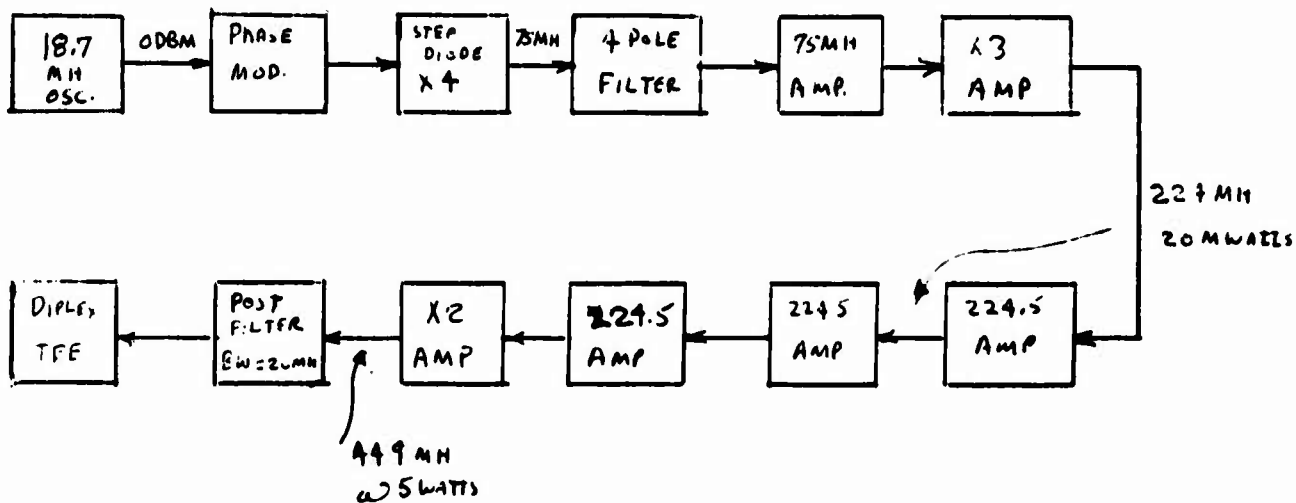

Case 1: Assume ideal noiseless transmitter (i.e., NF = 0 db).

$$P_{g \text{ Transmitter}} = \text{Power gain of transmitter} = \frac{5 \text{ watts}}{1 \text{ milliwatt}} = 5000 \text{ or } 37 \text{ db}$$

$$K_T = -174 \text{ dbm}/\text{Hz}$$

$$F = 0 \text{ db}$$

$$B = 20 \text{ mc (i.e., determined primarily by the post and prefilters)}$$

$$B = 73 \text{ db}$$

Amount of noise from transmitter generated by noise,  $K_T$  only\*, at preselector output (20 mc BW), assuming no post filter. (Assume no significant insertion loss in preselector for 421 mc  $\pm$  10 mc band)

$$\begin{array}{l} \text{Amount of noise from} \\ \text{transmitter at preselector} \\ \text{output} \end{array} = \begin{array}{l} -KT \quad B \quad F \quad Pg \\ -174 \quad + 73 \quad + 0 \quad + 37 \end{array} = -64 \text{ dbm}^{**}$$

$$\begin{array}{l} \text{Amount of noise at preselector} \\ \text{output due to receiver without} \\ \text{Diplexing transmitter} \end{array} = \begin{array}{l} KT \quad B \quad F \\ -174 \quad + 73 \quad + 6 \end{array} = -95 \text{ dbm}$$

$\therefore$  minimum post filter attenuation required of transmitter output at 421 mc  
 $= 95 - 64 = 31 \text{ db}$ .

This is, of course, for our case of an ideal transmitter noise figure of 0 db.

For a bandpass post filter whose bandwidth = 20 mc and a 6 db/oct/pole slope, we have:

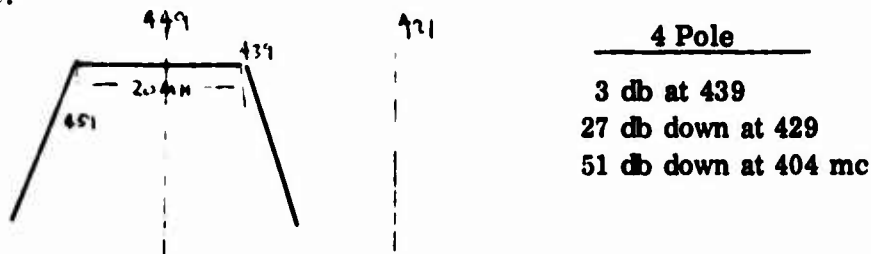

\* Assuming Gaussian type noise is a fair approximation, even though class C stages are used.

\*\* Assuming that all multipliers and amplifiers of transmitter are wideband (i.e., generate noise over BW, say  $\gg$  10 mc output BW related to 449 mc and  $\approx$  constant amplitude). This is, of course, our case.

From the above, we would need a minimum 4 pole post filter to reject the transmitter noise, in the receiver band, to a level equal to that attributed to the receiver alone.

Case 2. Same as Case 1, except NF of transmitter = 10 db.

The result would be the same as in Case 1, except we would require a 41 db rejection at 421 mc.

4 pole filter would be a bare minimum

Case 3. Same as 2, except that we must realize that the transmitter noise has to be  $\gg$  that generated by the receiver front end alone, to ensure no appreciable receiver sensitivity degradation.

For a 10 percent degradation, this would mean that the noise from the transmitter should be 10 db down from that generated by the receiver (assuming uncorrelated noise sources).

The result is a minimum post filter attenuation of 51 db at 421 mc.

5 Pole

3 db down - 439 mc  
33 db down - 429 mc  
63 db down - 409 mc.

Minimum 5 pole filter.

Case 5. Actual measured case using 3 pole post filter of 20 mc bandwidth.

Receiver sensitivity hurt by  $\approx$  20 db when Diplexing.

Amount of noise power at receiver input due to receiver = -95 dbm

Amount of noise power at receiver input due to receiver  
and transmitter = - 95 + 20  
-75 dbm

Amount of effectif filtering by post filter at 421 mc = 30 db calculated  
26 db measured.

Amount of transmitter noise in 20 mc bw before post filter = -75 dbm+26 = -49 dbm.

What transmitter NF does this represent:

$$N. F. \text{ Transmitter, calculated from measurements} = -174 + 73 - 37 + NF = 49 \text{ dbm}$$

$$NF_{\text{Transmitter}} = 15 \text{ db}$$

Case 5. How many poles are required in the post filter to not degrade the NF of the receiver by more than 10 percent when the transmitter NF = 15 db?

$$\begin{aligned} \text{Amount of rejection required of post filter at 421 mc} &= -174 + 73 + 15 + 10 + 37 + 95 \\ &= 56 \text{ db.} \end{aligned}$$

6 Pole Minimum (Need 7)

3 db - 439  
39 db - 429  
73 db - 409

Case 6. Same as Case 5, except instead of 10 percent, we take 1 percent of total receiver noise.

$$\begin{aligned} \text{Amount of post filter rejection at 421 mc} &= 66 \text{ db} \end{aligned}$$

7 Pole Minimum (Need 8)

3 db - 439  
45 db - 429  
87 db - 409

Case 7. What is the NF of the last transmitter stage alone?

13 db loss in receiver sensitivity using only last stage as only wideband noise generation source (Sierra 420A is  $\approx 1$  mc BW and used as driver to last stage).

$$\begin{aligned} \text{Amount of noise at preselector output due to receiver alone} &= -95 \text{ dbm} \end{aligned}$$

$$\begin{aligned} \text{Amount of noise at preselector out put due to transmitter last stage} &= -95 + 13 = -82 \text{ dbm.} \end{aligned}$$

Last transmitter stage, noise  
related to it (other side of A3-  
pole post filter) =  $-82 \text{ dbm} + 26 \text{ dbm} = -56 \text{ dbm}$

Last transmitter stage  
power gain =  $5 \text{ db}$

Last stage transmitter noise  
referred to input =  $-56 - 5 = -61 \text{ db}$

KTB noise at last stage transmitter input =  $-174 + 7 = 101 \text{ dbm}$

∴ last stage NF =  $101 - 61 = \underline{40 \text{ db}}$

### Conclusions

1. Require minimum of 7 poles to satisfy filtering requirements of post filter.
2. NF of transmitter of 15 db is reasonable.
3. NF of last stage of 40 db is also reasonable.

**APPENDIX B**

**SYSTEM BANDWIDTH REQUIREMENTS**

## APPENDIX B

### SYSTEM BANDWIDTH REQUIREMENTS

The spectral distribution of a signal, which has been frequency modulated by multiplier tones, has been treated by L. J. Gracoletts, in the Proceedings of the IRE, July 1947. Basically, the sideband distribution consists of all the possible combinations of the sum and differences of the Bessel functions of the individual modulating tones taken six (6) at a time. The equation of the distribution is:

$$a = A_0 \prod_{\lambda=1}^{\infty} \left[ \sum_{m_{\lambda}=-\infty}^{\infty} J_{m_{\lambda}}(z_{\lambda}) \right] \cos \left[ \left\{ \omega_0 (1 + C_0) + \sum_{\lambda=1}^{\infty} m_{\lambda} \omega_{\lambda} \right\} + \sum_{\lambda=1}^{\infty} m_{\lambda} \theta_{\lambda} \right]$$

where  $z$  is the mod index of signal  $i$ . The product of the summation will create all possible combinations of sums and differences of the various Bessel functions. The spectrum is derived for six (6) tones, each with a mod index of 2.4. 2.4 was chosen in order to reduce the number of terms, i.e.,  $J_0(2.4) = 0$ . The actual signal format in MAT is six (6) tones, each with a mod index of 2.5.

To simplify, the problem was broken into blocks of combinations. For example, there are sixty-four ( $6^4$ ) combinations created by  $f_1, f_2, f_3, f_4, f_5$  and  $f_6$  by the first order Bessel function product of each of the signal  $J_1^6$ . The number of combinations thus derived was 124,568. Following is a list of these combinations, their individual amplitudes, power in each sideband, the number of spectral lines of particular combinations and the total power contained in these combinations.

Frequency Product	Bessel Functions	$\Pi$ Amplitude	$(\Pi)^2$ (Amplitude) <sup>2</sup>	$\Sigma$ No. of Spectral Lines	Total Power
$f_1, f_2, f_3, f_4, f_5, f_6$	$J_1^6$	.01982	.0003928	64	.025140
$2f_1, f_2, f_3, f_4, f_5, f_6$	$J_1^5, J_2$	.0164211	.0002696	384	.103500
$2f_1, 2f_2, f_3, f_4, f_5, f_6$	$J_1^4, J_2^2$	.013605	.0001851	960	.177700
$2f_1, 2f_2, 2f_3, f_4, f_5, f_6$	$J_1^3, J_2^3$	.01127245	.000127068	1280	.162600
$2f_1, 2f_2, 2f_3, 2f_4, f_5, f_6$	$J_1^2, J_2^4$	.0093384	.0000872057	960	.083717
$2f_1, 2f_2, 2f_3, 2f_4, 2f_5, f_6$	$J_1, J_2^5$	.007735	.00005983	384	.022970
$2f_1, 2f_2, 2f_3, 2f_4, 2f_5, 2f_6$	$J_2^6$	.006409	.00004421	64	.002829
$3f_1, f_2, f_3, f_4, f_5, f_6$	$J_1^5, J_3$	.007544	.00005691	384	.021850
$3f_1, 2f_2, f_3, f_4, f_5, f_6$	$J_1^4, J_2, J_3$	.006253	.00003907	1920	.075010
$3f_1, 2f_2, 2f_3, f_4, f_5, f_6$	$J_1^3, J_2^2, J_3$	.005179	.000026822	3840	.102996
$3f_1, 2f_2, 2f_3, 2f_4, f_5, f_6$	$J_1^2, J_2^3, J_3$	.004289518	.00001840	3840	.070660
$3f_1, 2f_2, 2f_3, 2f_4, 2f_5, f_6$	$J_1, J_2^4, J_3$	.003554	.00001263	1920	.024250
$3f_1, 2f_2, 2f_3, 2f_4, 2f_5, 2f_6$	$J_2^5, J_3$	.002944	.000008667	384	.003328
$3f_1, 3f_2, f_3, f_4, f_5, f_6$	$J_1^4, J_3^2$	.001826	.000003334	960	.003201
$3f_1, 3f_2, 2f_3, f_4, f_5, f_6$	$J_1^3, J_2, J_3^2$	.002379	.000005660	3840	.021730
$3f_1, 3f_2, 2f_3, 2f_4, f_5, f_6$	$J_1^2, J_2^2, J_3^2$	.001971	.000003685	5760	.022380

NOT REPRODUCIBLE

Frequency Product	Bessel Function	Amplitude	(Amplitude) <sup>E</sup>	No. of Spectral Lines	Total Power
$3f_1, 3f_2, 2f_3, 2f_4, 2f_5, 2f_6$	$J_2 J_2^3 J_3^2$	.001633	.000002667	3840	.000210
$3f_1, 3f_2, 2f_3, 2f_4, 2f_5, 2f_6$	$J_2^4 J_3^2$	.001353	.000001831	960	.001758
$3f_1, 3f_2, 3f_3, 2f_4, 2f_5, 2f_6$	$J_2^3 J_3^3$	.001093	.000001195	1280	.001529
$3f_1, 3f_2, 3f_3, 2f_4, 2f_5, 2f_6$	$J_2^2 J_2 J_3^3$	.000905	.000000819	3840	.003145
$3f_1, 3f_2, 3f_3, 2f_4, 2f_5, 2f_6$	$J_2 J_2^2 J_3^3$	.000750	.000000606	3840	.002306
$3f_1, 3f_2, 3f_3, 2f_4, 2f_5, 2f_6$	$J_2^3 J_3^3$	.0006214	.0000003867	1280	.000495
$4f_1, 2f_2, 2f_3, 2f_4, 2f_5, 2f_6$	$J_4 J_2^5$	.002450	.000006003	384	.002305
$4f_1, 2f_2, 2f_3, 2f_4, 2f_5, 2f_6$	$J_4 J_2 J_2^4$	.001987	.000003948	1920	.007580
$4f_1, 2f_2, 2f_3, 2f_4, 2f_5, 2f_6$	$J_4 J_2^3 J_2^2$	.001182	.000002820	3840	.010800
$4f_1, 2f_2, 2f_3, 2f_4, 2f_5, 2f_6$	$J_4 J_2^3 J_2^2$	.001393	.000001940	3840	.007450
$4f_1, 2f_2, 2f_3, 2f_4, 2f_5, 2f_6$	$J_4 J_2^4 J_2^3$	.001154	.000001331	1920	.002556
$4f_1, 2f_2, 2f_3, 2f_4, 2f_5, 2f_6$	$J_4 J_2^5$	.00091614	.0000009142	384	.00351
$4f_1, 3f_2, 2f_3, 2f_4, 2f_5, 2f_6$	$J_4 J_3^2 J_2^4$	.000932	.0000008686	1200	.003040
$4f_1, 3f_2, 2f_3, 2f_4, 2f_5, 2f_6$	$J_4 J_3 J_2 J_2^3$	.0007126	.0000005969	7680	.004584
$4f_1, 3f_2, 2f_3, 2f_4, 2f_5, 2f_6$	$J_4 J_3 J_2^2 J_2^2$	.0006100	.0000004096	23040. 987093	.009440
$4f_1, 3f_2, 2f_3, 2f_4, 2f_5, 2f_6$	$J_4 J_3 J_2^2 J_2$	.0005301	.0000002810	7680	.002158
$4f_1, 3f_2, 2f_3, 2f_4, 2f_5, 2f_6$	$J_4 J_3 J_2^4$	.00043936	.00000019304	1920	.000371
$4f_1, 3f_2, 3f_3, 2f_4, 2f_5, 2f_6$	$J_4 J_3^2 J_2^3$	.000355	.000000126	3840	.000484
$4f_1, 3f_2, 3f_3, 2f_4, 2f_5, 2f_6$	$J_4 J_3^2 J_2 J_2^2$	.0002940	.000000086436	11520	.000996
$4f_1, 3f_2, 3f_3, 2f_4, 2f_5, 2f_6$	$J_4 J_3^2 J_2^2 J_2$	.000243568	.000000059325	11520	.000683
$3f_1, 3f_2, 3f_3, 3f_4, 2f_5, 2f_6$	$J_3^4 J_2 J_2$	.000344605	.000000118753	1920. 994360	.000228

NOT REPRODUCIBLE

The distribution of the different sums and differences were then derived and the power content in each megacycle at bandwidth was determined.

The spectral distribution is almost continuous and can only be graphically represented by its peak values and power density. Figure 1 is a graph showing the peak value of the spectral lines versus BW. The abscissa is in voltage compared to the unmodulated carrier value. It can be noted that 1 percent of maximum occurs at approximately 8.0 mcs on a two-sided bandwidth of 16.0 mcs. It should be remembered that the curve is a peak envelope, and the number of spectral lines would make the spectral distribution appear almost continuous. A more meaningful curve may be the power density distribution. Figure 2 shows the power distribution in density or power contained in each megacycle of two side bandwidth. We can note that the power density has dropped to 40 db below the total signal content at approximately 16.0 mcs. Figure 3A is a curve of the integrated power content as a function of bandwidth. As noted, 99 percent of the power is contained in 12 MHz of bandwidth.

Figure 3A represents the amount of total power contained within a frequency band (double sided), about center frequency, for six tones of mod index 2.4 each. This curve was derived without taking into consideration a filter amplitude response or assumed one in which the band of interest was flat and the skirts infinitely steep (i.e., a square response). This should not imply that since 99 percent of the power is contained in 12 MHz of bandwidth, then a filter 3 db bandwidth of 12 MHz can be used.

It can be seen from Figure 3B that this is far from true for practical filter responses, and especially those obtained in the MATS transponder.

Case 1. Filter response between 3 db points in Figure A,  $BW_{3db} = 12$  mc.

#### Diplexer Multipole Simulation

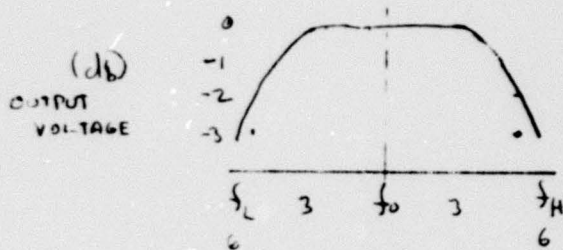

Figure A

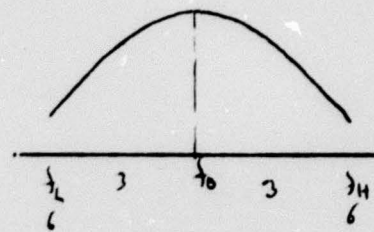
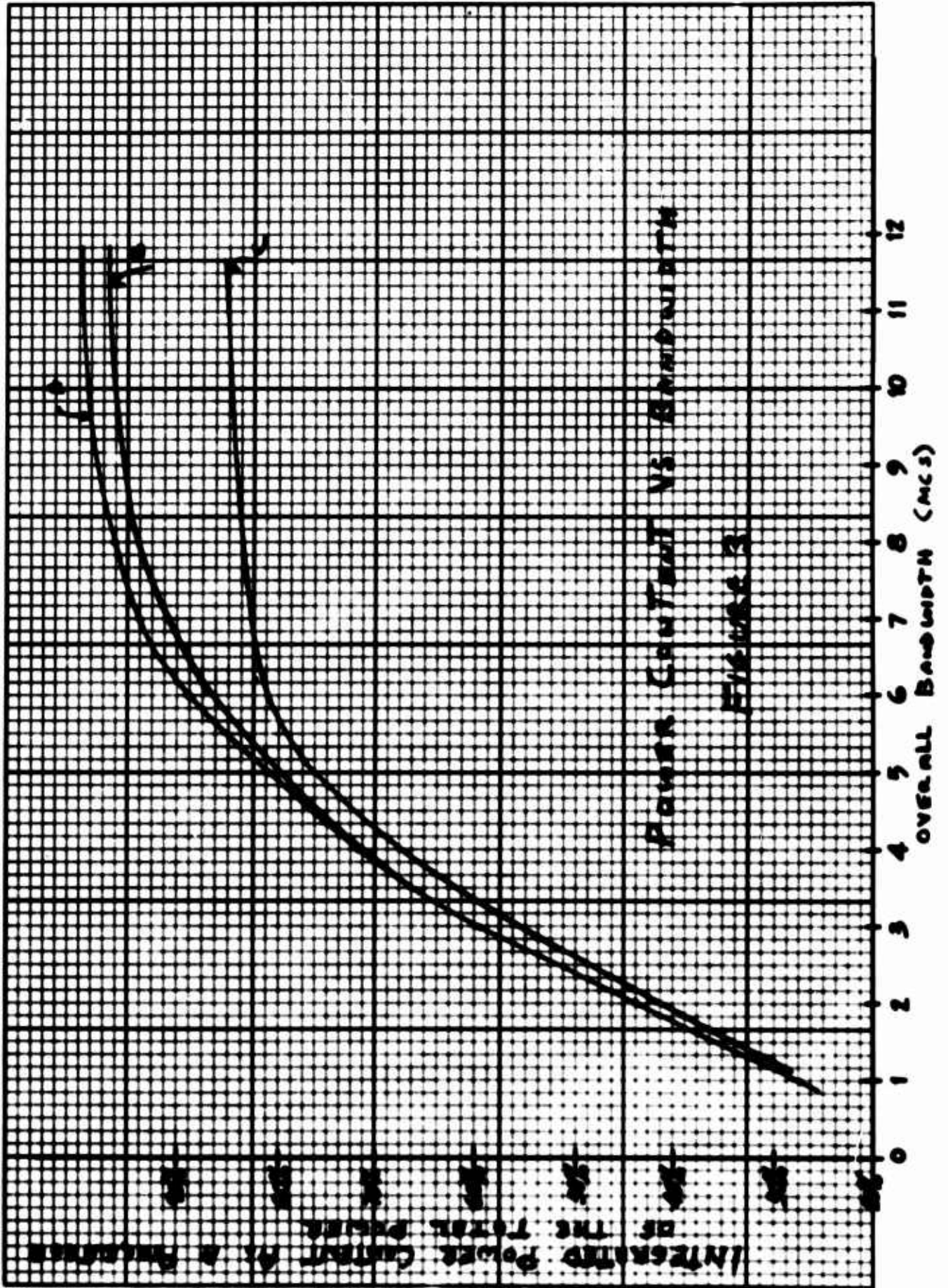

Figure B







**Case 2. Single pole response due to transmitter output into post filter (assuming diplexer filter ideal square response), see Figure B and Figure 3, curve B, for 12 MHz bandwidth.**

**Thus, the bandwidth of the transmitter final amp and diplexer should be wider than 12 MHz in order to pass near 99 percent of the transmitter power.**

APPENDIX C

NOISE BANDWIDTH CORRECTION FACTOR

## APPENDIX C

### NOISE BANDWIDTH CORRECTION FACTOR

Since it is well known that single pole filters have 3 db bandwidths that are narrower than their actual noise bandwidths, then, when calculating S/N ratios for a receiver in which this type of filter is used a common correction factor is used.

$$\text{Noise Bandwidth} = \pi/2 \times (3 \text{ db Bandwidth})$$

This factor is almost, but not quite, correct for the crystal filters used in the MATS transponder. The above  $\pi/2$  factor is related to a single pole filter with a 6 db/oct skirt selectivity.

Since the MATS crystal filters are used in a PFFB loop, the slope is 6 db/oct. In addition, the common spurious crystal modes add to the over-all noise bandwidths.

Figure 1 is a closed loop voltage plot of a typical crystal. The 3 db bandwidth measured is 4.1 KHz. Figures 2 and 3 are plots of (voltage)<sup>2</sup> versus frequency for the same filter. Calculating the noise power bandwidth graphically, we have

$$\text{Noise power bandwidth} = 9 \text{ KHz.}$$

$$Q = \frac{\text{Noise power bandwidth}}{3 \text{ db bandwidth}} = \frac{9 \text{ kc}}{4.1 \text{ kc}} = 2.2, \text{ or } 3.4 \text{ db}$$

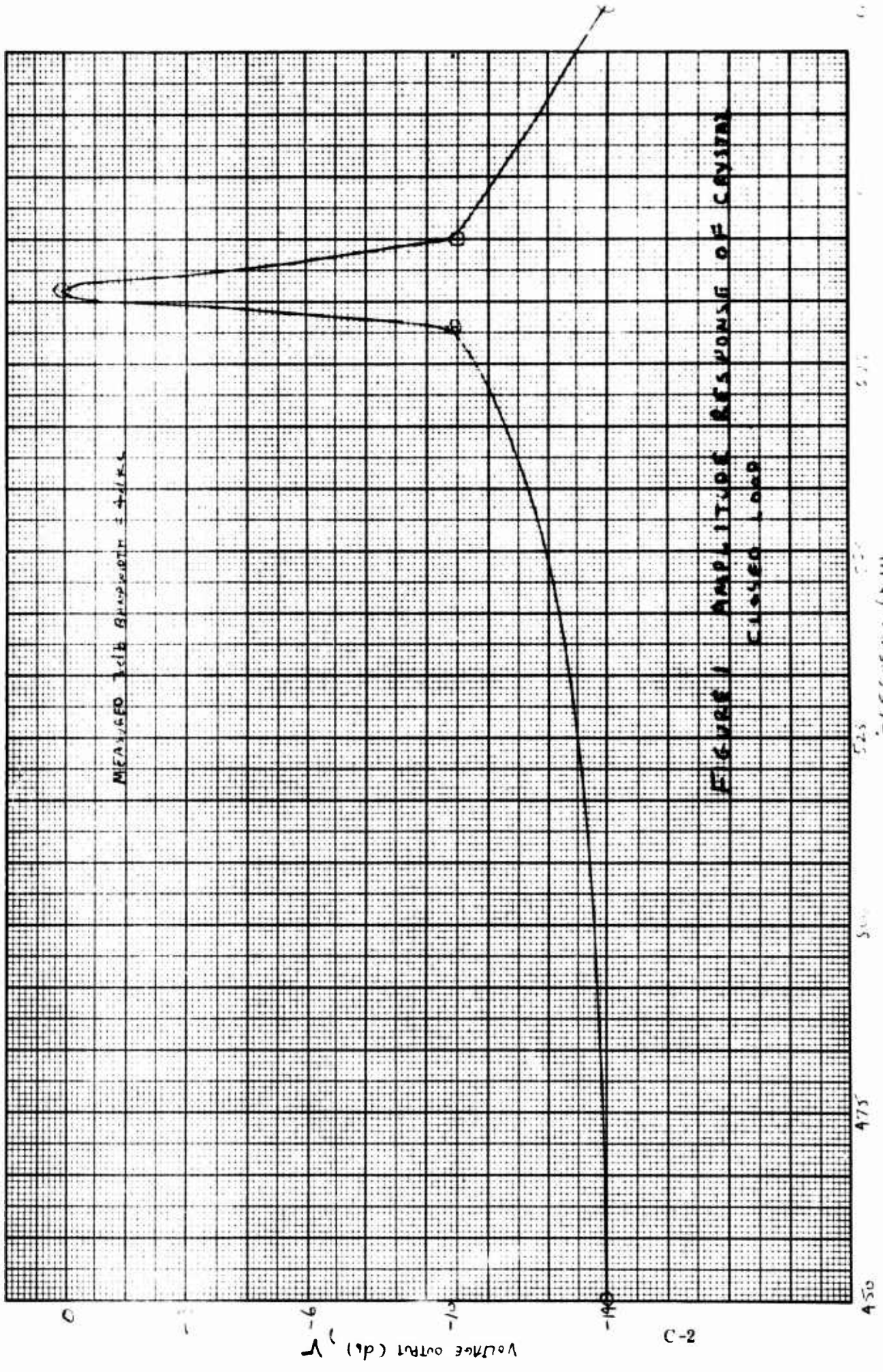

C-2

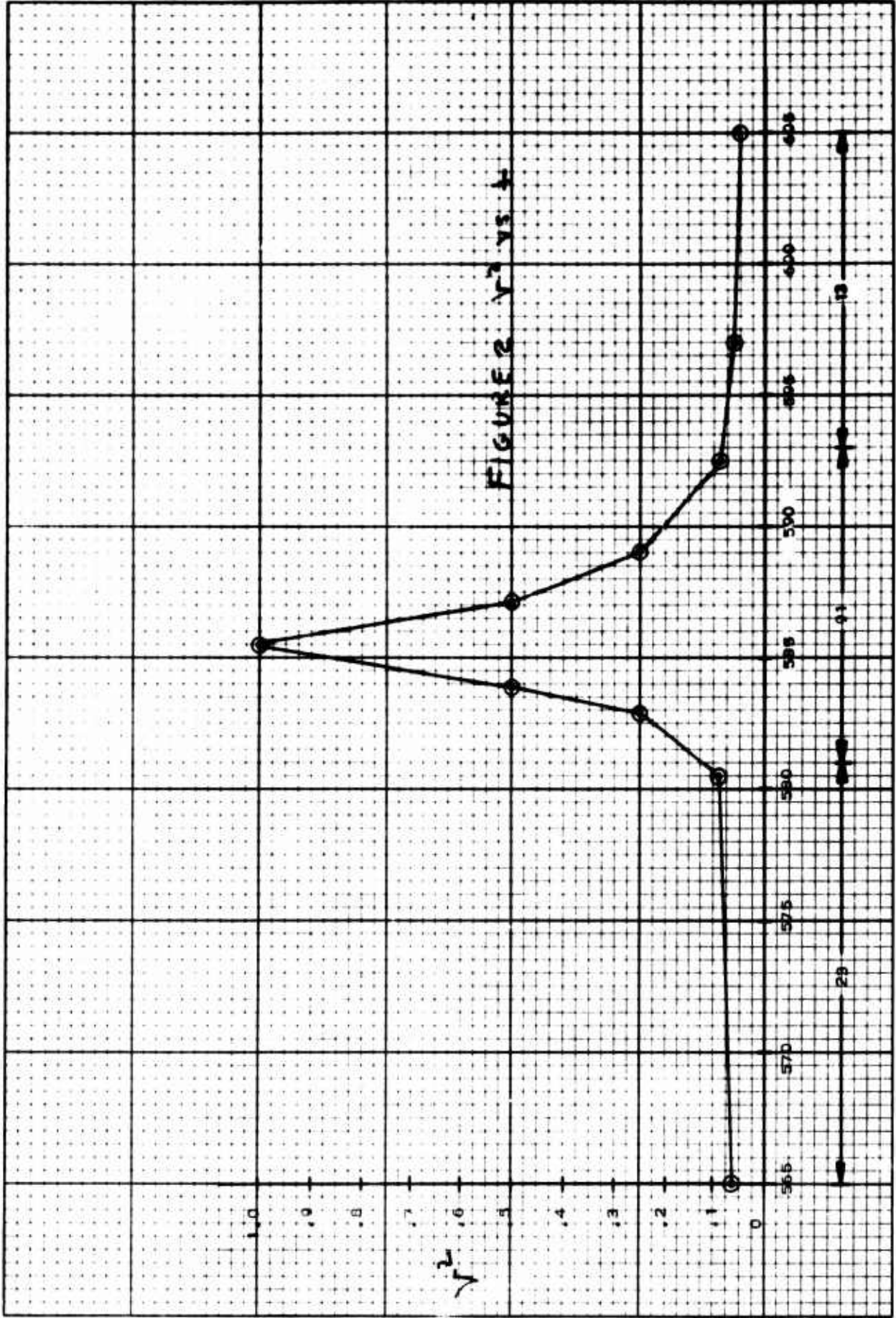

K-Σ 10 X 10 TO THE INCH 46 0703  
 7 X 10 INCHES  
 MADE IN U.S.A.  
 KEUFFEL & ESSER CO.

