

Jan. 31, 1971

AFOSR-TR-71-093 1

AD722084

PROGRESS REPORT NO. 2

Combustion Mechanism of Composite Propellants During Depressurization

July 1 - Dec 31, 1970

by

J. A. Steinz und H. Selzer

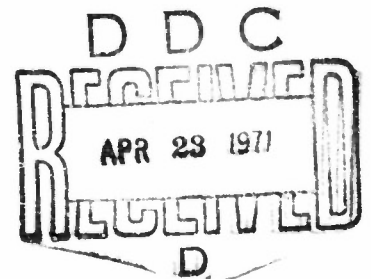

DEUTSCHE FORSCHUNGS-u.VERSUCHSANSTALT FÜR LUFT-und RAUMFAHRT e.V. (DFVLR)

Institut für Chemische Raketenantriebe

3041 Trauen

West -Germany

THIS RESEARCH HAS BEEN SPONSORED IN PART BY THE AIR FORCE OFFICE OF SCIENTIFIC RESEARCH THROUGH THE EUROPEAN OFFICE OF AEROSPACE RESEARCH, OAR, UNITED STATES AIR FORCE UNDER CONTRACT No. F61052-70-C-0013.

Reproduced by
NATIONAL TECHNICAL
INFORMATION SERVICE
Springfield, Va. 22151

~~1. This document has been approved for public release and sale; its distribution is unlimited.~~

30

"Combustion Mechanism of Composite Propellants During Depressurization"

by

J.A. Steinz and H. Selzer

I. INTRODUCTION

During the first six months of the subject contract period the apparatus required to investigate the depressurization extinguishment behavior of solid propellants was brought to the final stage of refinement. The first extensive series of planned testing was completed for a particular ammonium perchlorate (AP) propellant and these results, describing some interesting and important new phenomena, were presented at the 13th Symposium (International) on Combustion in August of last year. This presentation was submitted as our first six-monthly progress report and is now accepted for publication in the January issue of the "Combustion Science and Technology" journal.

In the second six-month period of the contract, covered by the present progress report, the investigation series was repeated in the normal way for a number of propellant composition types and initial pressure levels. The efforts give evidence of the generality of the newly found phenomena and define more clearly the effect of these parameters on the dynamic behavior of the flame. The two sections of this report give a summary of the find-

ings and also describe the developed apparatus and procedures in greater detail than was possible in the earlier Symposium publication.

II. APPARATUS AND EXPERIMENTAL PROCEDURE

The apparatus, shown schematically in Fig.1, is capable of taking a number of simultaneous measurements, instantaneous pressure, a number of spectral line intensities and high-speed movie photographs, during the depressurization process. The initial pressure and imposed depressurization rate can be varied at will for each individual test. After each test, the burned surface of those samples that were permanently quenched, are examined under high magnification with a scanning electron microscope (Cambridge Instruments - Mk2A).

The combustion chamber can withstand 200 atm pressure and has 135 cm³ internal volume of complicated geometry (Figs. 2 and 3). The vessel is designed to accommodate a 1,5 cm x 2,5 cm x 3,5 cm rectangular propellant block and consists of two quartz side windows, a nitrogen inlet port, two small side-vent nozzles, and a large pressure release nozzle that is kept closed by the double diaphragm device until when the rapid depressurization is to occur. Movie photographs and spectral line intensity measurements of the flame are taken through these two quartz windows.

In an actual test, nitrogen is allowed to flow past the propellant sample until just before (ca. 80 ms) the two aluminum burst discs blocking the main nozzle are broken by releasing the preset pressure in the cavity between these discs; the burst discs are chosen to withstand 50% of the chamber pressure but not the full chamber pressure; the pressure in the cavity between these discs is preset at 50% of the chamber pressure. The depressurization rate is varied from test to test by changing the diameter of the main nozzle, from 25 mm to 6 mm in our test series.

The spectrograph (Hilger and Watts E498) has been modified so that the intensities of the OH, NH, CN, and Na lines can be measured individually with IP28 photomultipliers. The maximum bandwidth of each of these lines is 80 \AA . For comparative purposes, the intensity of a spectral window of similar bandwidth in the carbon continuum range at 4880 \AA is also measured. Fig. 4 gives the circuit of each photomultiplier with its impedance matcher built of an operational amplifier block (Fuba VRB). The impedance matcher is there to avoid interference by stray signals in the line from the test cell to the measurement bunker. The optical system is so that a zone of dimensions $0,5 \text{ cm} \times 0,02 \text{ cm}$ in the flame is seen by the slit of the spectrograph. Control of the instant of depressurization (see below) is such that these measurements are taken $0,1$ to $0,3 \text{ cm}$ above the propellant surface when depressurization occurs.

The electronic measurement system, layed out for a frequency response of 20 KHz , is shown schematically in Fig. 5. Fig. 5 (a) is a block diagram of the circuitry during a test run. All signals, from the five photomultipliers, the two timing oscillators and the pressure transducer, are amplified and simultaneously recorded with a tape recorder (CEC Type VR-3300) and a galvanometer recorder (CEC Type 5-124 with Type 7-362 galvanometers of 2000 Hz frequency response). The system has been so designed that the circuitry can be switched to that of Fig. 5 (b) for tape playback at reduced speed. The speed factor is chosen for good resolution of the final galvanometer trace and also to guarantee an overall frequency response of 20 KHz .

An RC oscillator drives a neon light in the camera (Fairchild) and by inductive coupling as in Fig. 10, the same signal is brought to the galvanometer recorder and the tape recorder. A separate quartz driven oscillator (Tektronix 180A) provides the absolute time base for measurements. Instantaneous pressure is measured with a piezoelectric transducer (AVL type QP500 cvk) that is watercooled, temperature compensated and mounted with its diaphragm almost flush with the inside wall of the combustion chamber, to ensure high frequency response. The signal is amplified with a Vibro-

meter type TA-3/c charge amplifier. The system is periodically calibrated as shown in Fig. 6. The calibrations in Fig.6 were taken two months apart and show the excellent reproducibility obtained.

With the exception of the pressure signal, all measurements are amplified with DC amplifiers (Fig.5). Only the signals of the weakest spectral lines (306, 336, and 388 nm) are amplified with high amplification differential DC amplifiers (DANA type 2820). All other signals are taken by self-constructed amplifiers (using Fuba type VRB and VRL operational amplifier building blocks) as shown in Fig. 4. Their amplification is variable from 35 x to 1250 x (Fig.7) and their measured frequency response is 1,5 dB at 20 KHz (Fig.8). Switch A shown in Fig.4 is to switch the amplification factor from variable to 5,3 x, the amplification factor required to drive the galvanometers during replay of the tape recorder.

The switching of the circuitry from the test mode to the replay mode, as in Figs. 5(a) and 5(b), is accomplished by means of an electrically shielded relay for each channel as shown in Fig. 9. All contacts of each relay are connected to a patch panel so that any amplifier can be incorporated flexibly according to the requirements of each particular measurement channel.

The time sequencing control circuit is shown in Fig. 10. All operations during the course of a test are controlled by a motor driven time sequencer with eight separate adjustable discs (S1, S2, ...). A typical setting for the various discs and the two time-delay relays is shown in the table below.

TABLE I (A). TIME SEQUENCER SETTINGS (Refer to Fig. 10)

Operation	Sequencer Disc No.	On (sec)	Off (sec)
Sequencer motor	S2	0,2	9,0
Galvo. recorder	S8	0,3	8,5
Relay RII (Double diaphr.)	S4	0,4	2,0
Valve VII Supply (Double diaphr)	S7	1,0	8,1
Valve V I Supply (N ₂)	S5	3,0	7,7
Ignition	S6	3,5	4,5
Camera	S1	3,6	4,8
Relays R I and R II	S3	3,9	8,5

TABLE I (B). DELAY SETTINGS OF RELAYS

Relay	Operates	Voltage Contacts	On Delay (ms)	Voltage Contacts	Off Delay (ms)
R I	N ₂ -supply	Close	0	Open	210
R II	Double Diaph.	Open	420	Close	0

TABLE I (C). VALVE DELAY TIMES

Valve	Mechanical Delay (ms)
V I	350
V II	210

The sequence of operations during a test is as follows:

(a) Circuit preparation

- 1) All power supplies and the ignition key are turned on.
- 2) The pushbutton T is depressed setting the sequencing motor into operation.
- 3) After 0,2 sec., disc S2 closes the supply to the sequencer motor; the motor runs until the sequence end, even when button T is released.
- 4) After 0,3 sec., disc S8 sets the galvanometer recorder into operation.
- 5) After 0,4 sec., disc S4 supplies current to relay R II and the contacts opens after a preset (irrelevant here) time delay.

- 6) After 1,0 sec, disc S7 closes bringing the 24 v supply to the contacts of relay R II.
- 7) After 2,0 sec, disc S4 opens causing R II contacts to close without delay and in so doing, valve V II pre-pressurizes the cavity between the 2 diaphragms of the double diaphragm device. At the same time, one of the neon light in the camera is switched on. The moment of switching is recorded inductively by the galvanometer recorder. In this way, a common time base between film, magnetic tape, and galvanometer trace is achieved.
- 8) After 3,0 sec, disc S5 supplies current to valve V I which pre-pressurizes the combustion chamber to the desired preset test pressure.

(b) Ignition.

- 9) After 3,5 sec, disc S6 supplies current to the ignition wire.
- 10) After 3,6 sec, disc S1 starts camera giving it enough time to run to the full speed of 2000 frames/sec when the flame comes into the field of view and the depressurization is to occur.
- 11) After 3,9 sec, disc S3 activates the relay which closes its own holding contact and at the same time, cuts the voltage to R I and supplies voltage to R II; voltage to valves V I and V II is cut after a delay of 0,21 sec and 0,42 sec respectively. Valves V I and V II have an inherent mechanical delay time of 0,35 sec and 0,21 sec and so, they both close after 0,54 sec and 0,63 sec, respectively, i.e., the nitrogen supply is cut 0,54 sec after S3 is actuated and the double diaphragm device releases the main nozzle for depressurization after 0,63 sec. The timing of S3 and the delay times of relays R I and R II are always so set that the N_2 supply is cut 0,09 sec before depressurization is to occur and that depressurization occurs when the section of the flame viewed by the spectrograph slit is 0,1 - 0,3 cm (real distance) above the propellant surface; the propellant is allowed to burn steady-

ly for about 1,0 sec after ignition and before depressurization.

(c) System shut-down and reset.

- 12) S6 cuts the ignition circuit after 4,5 sec
- 13) S1 turns the camera off after 4,8 sec
- 14) S5 opens after 7,7 sec
- 15) S7 opens after 8,7 sec
- 16) S8 switches the galvanometer recorder off after 8,5 sec
- 17) S2 turns the sequencer motor off after 9,0 sec
- 18) All power supplies to the control circuit are manually turned off, the holding current to the relay operated by S3 is cut and the entire system is reset for the next test.

Preparation of samples.

For depressurization tests and for investigation with the scanning electron microscope demand some special precautions:

The propellant samples for burning in the combustion chamber are first cut to 1,5 cm x 2,5 cm x 3,5 cm size and then leached in water. After mounting in the propellant holder the bare side surfaces inhibited with a silicone compound. A planar regressing surface during the steady state portion of the test is achieved by covering the entire ignition surface with a fast flashing material that is in turn ignited by an electrically heated nichrome wire.

Those samples that have been permanently quenched are prepared by cutting small (0,5 cm x 0,5 cm) representative sections out of the burned surface. These are mounted on a metal plate with an electrically conducting glue and a thin composite layer of gold-graphite-gold or graphite alone (depending on the nature of the quenched surface) is then vaporized under vacuum

onto the quenched surface. This surface is then photographed under high magnification (up to 2000 x) with the scanning electron microscope and when important, these photographs are quantitatively analysed to obtain measurements of the statistical size distribution of the exposed AP crystals.

III. EXPERIMENTAL RESULTS

The first six-monthly progress report describes in detail the results of a test series carried out for an initial pressure of 45 atm with 24% carboxyl terminated polybutadiene (PBCT) + 76% AP of 25 μ mean particle size. It was found that the behavior of extinguishment depends strongly on the imposed depressurization rate. For the very highest initial depressurization rates ($> 16 \times 10^3$ atm/s), the gaseous flame goes out permanently within 1 ms due to freezing of the gaseous chemical reactions by the adiabatic expansion. For lower $(dP/dt)_0$, but still not low enough to affect permanent extinction ($> 7,5 \times 10^3$ atm/s), the gaseous flame also goes out within 1 ms but redevelops again after about 5 ms, the thermal relaxation time of the solid phase. This newly developed flame preferentially consumes the AP crystals from the propellant surface and in so doing, causes unsteady fluctuations in the gaseous (O/F) mixture ratio during the depressurization process. The redeveloped flame only quenches toward the end of the process. When $(dP/dt)_0$ is so low that permanent extinction does not occur, the qualitative behavior is the same. Under no circumstances was the dependence of pressure found to be an exponential function of time. The boundary for permanent extinguishment was found to be in good agreement with that of earlier investigators on the subject. It was found also that methods of quenching other than by depressurization, produce quenched surface structures that are vastly different in nature; relatively less effective quench methods give the AP better opportunity to react further during the quench process.

In the past months our investigations were extended to other propellant types. These propellants are summarized together with our determinations

of their permanent extinction boundaries in the table below. The pressure traces for each of the test series are given in Figs. 11 to 16.

TABLE II PROPELLANTS TESTED AND THEIR EXTINCTION BOUNDARIES
($P_0 \approx 45 \text{ atm}$)

Type	Binder	AP	Equivalence Ratio [†]	Flame Temperature ^{††}	Critical (dP/dt) lies in Range: -(atm/s)
1.1	24%FB	5 μ	0,35	1950 ^o K	(4,4-7,6)x 10 ³
1.2	24%PB	25 μ	0,35	1950 ^o K	(6,7-8,2)x 10 ³
1.5	24%PB	200 μ	0,35	1950 ^o K	(4,8-6,7)x 10 ³
Bx14	24%PB	25 μ	0,35	1950 ^o K	(3,7-4,2)x 10 ³
Bx16	24%PB	100 μ	0,35	1950 ^o K	(2,1-3,1)x 10 ³
PU	21%PU	150 μ	0,65	2630 ^o K	if, < 2 · 10 ³

[†]Equivalence ratio defined as mass of oxidizing species (O, Cl, F ...) present in the propellant (Oxidizer + fuel) divided by the mass of oxidizing present in the same propellant mixed to stoichiometric proportions; the stoichiometric ratio is that taken as that which leads to the products H₂O, CO₂, SO₂, HCl, N₂.

^{††}Flame temperature taken from the calculations of ref 2.

From the above table it is seen that the PBCT-AP propellant series 1.1, 1.2, and 1.5 have a noticeable higher extinction boundary than the Bx14, Bx16 series, even though their composition is ostensibly the same. The two propellant series were processed by the same manufacturer but at different times; so, as often shown by past experience,

batch to batch reproducibility plays an important role. The effect of AP particle size on the extinguishment boundary can not be discerned from the scatter in our results; for that, as shown by other investigators, we need to carry out the same test series at several initial pressure levels. N_0 (dP/dt)₀ could be found below which our polyurethane propellant continues burning. This probably has to do with the fact that the relatively underoxidized family of PU propellants often have a low pressure deflagration limit above 1 atm, the value of the final exhaust pressure in our case.

More interesting and closer in line with the objectives of our program, is the general observation that the flame of all six propellants tested show the same qualitative behavior as that summarized in the beginning of this section (see also Figs. 11 to 16); the phenomena observed are real and quite general. In parallel with the instantaneous pressure measurements, flame intensity measurements and scanning electron microscope analyses were made routinely as before. These results will be reported in detail in our final report when all findings can be put into a systematic coordinated form.

The first two propellant series were also tested at the lower initial pressure of 25 atm. Although all results have not been completely analysed, the qualitative behavior is the same; only the absolute numbers change. A new high pressure vessel has been built and put into operation to burn pure AP crystals (obtained from NWC, China Lake) at pressures up to 200 atm and then allow them to extinguish on a metal plate. The first several tests carried out high pressure yield valuable observations that can be reconciled with our understanding of the depressurization extinction process.

IV FUTURE WORK

We are now at the stage where a large amount of data has been amassed. Most of this has been analysed but can only be put to its full meaning in terms of the dynamic combustion mechanism after the completion of further critically planned testing. To complete the project in the next several months, we plan to:

- 1) Complete propellant series of Table II for $P_o = 25$ atm and 100 atm.
- 2) Test an aluminized AP propellant at $P_o = 25, 50$ and 100 atm.
- 3) Test a practical double base propellant at $P_o = 25, 50$ and 100 atm.
- 4) Investigate the surface structure of AP crystals quenched on a metal plate at various pressures in the range 1 - 200 atm.

REFERENCES

- 1) J.A. Steinz, H. Selzer
Depressurization Extinguishment of Composite Solid Propellants:
Flame Structure Surface Characteristics, and Restart Capability.
Progress Report No.1, Air Force Office of Scientific Research
Contract FG1052-70-C-0013, Washington/USA.
To be published in COMBUSTION SCIENCE AND TECHNOLOGY, Vol.3.No.1
January 1971.
- 2) C.L.Merkle, S.L.Turk, and M.Summerfield
Extinguishment of Solid Propellants by Rapid Depressurization
Aerospace and Mechanical Sciences Report No.880
(ONR Contract Nonr 1858 (32), July, 1969) Princeton, New Jersey-USA.

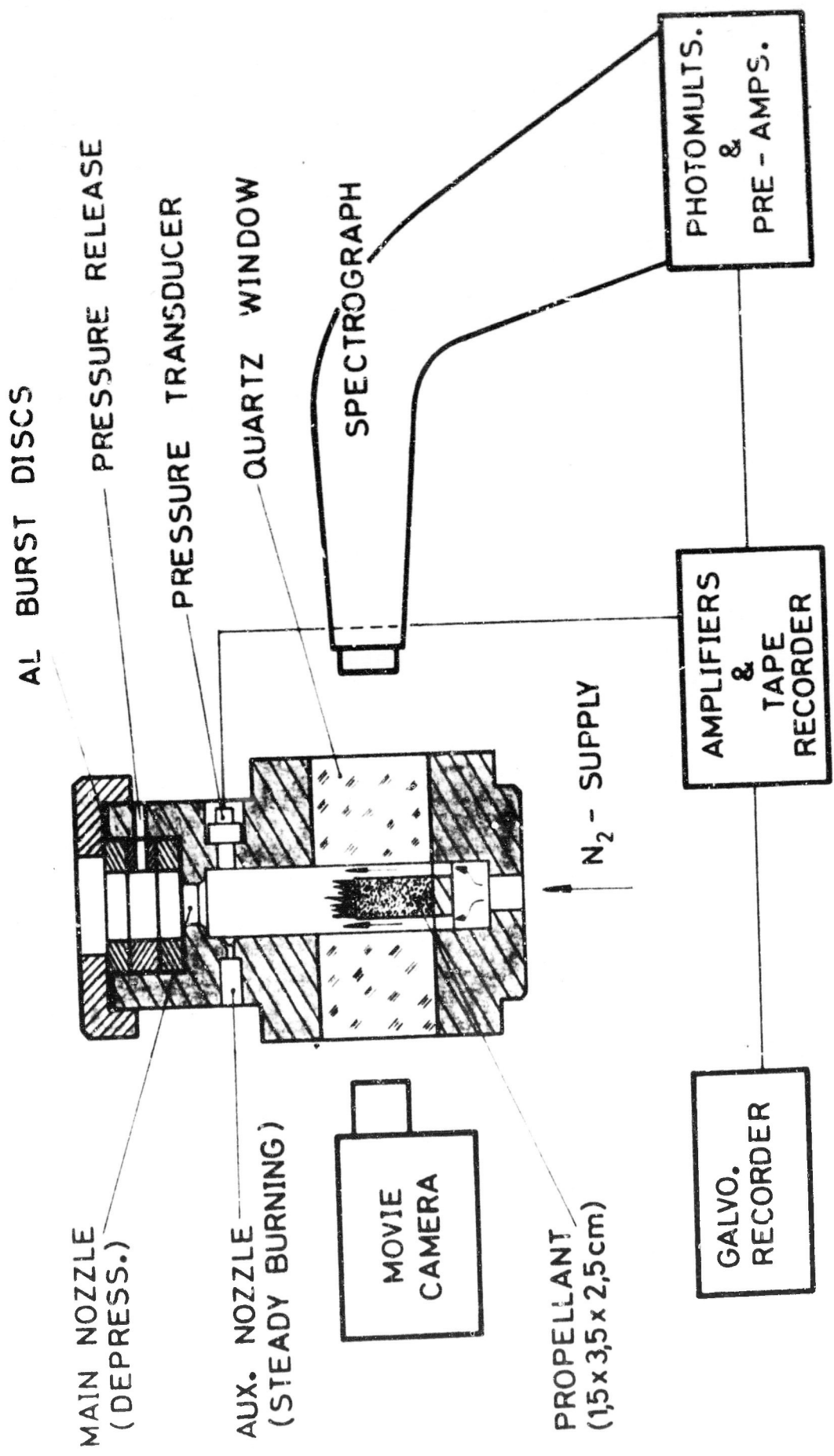

FIG1 DEPRESSURIZATION EXTINCTION EQUIPMENT

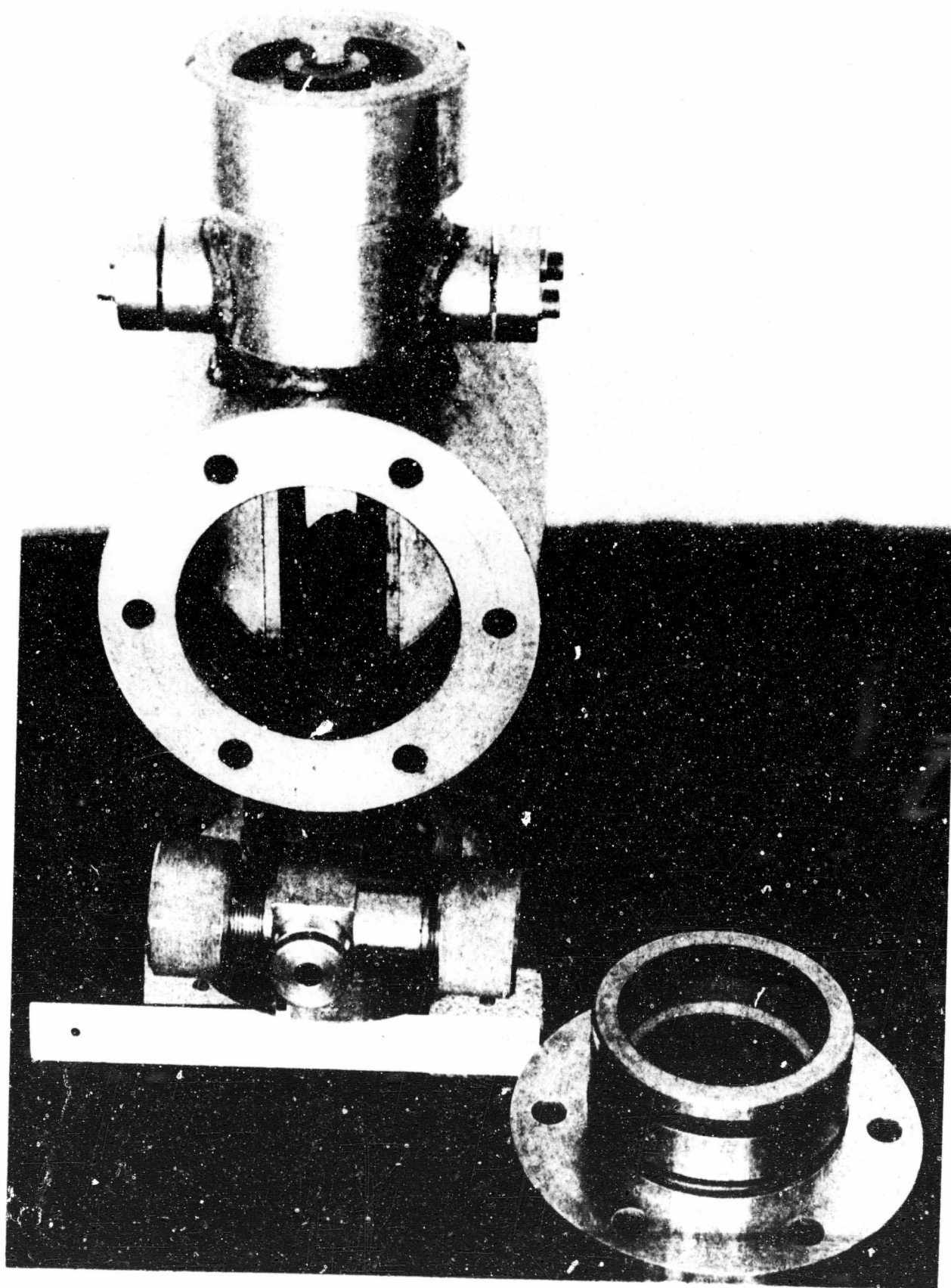

FIG. 2 SIDEVIEW OF THE COMBUSTION CHAMBER

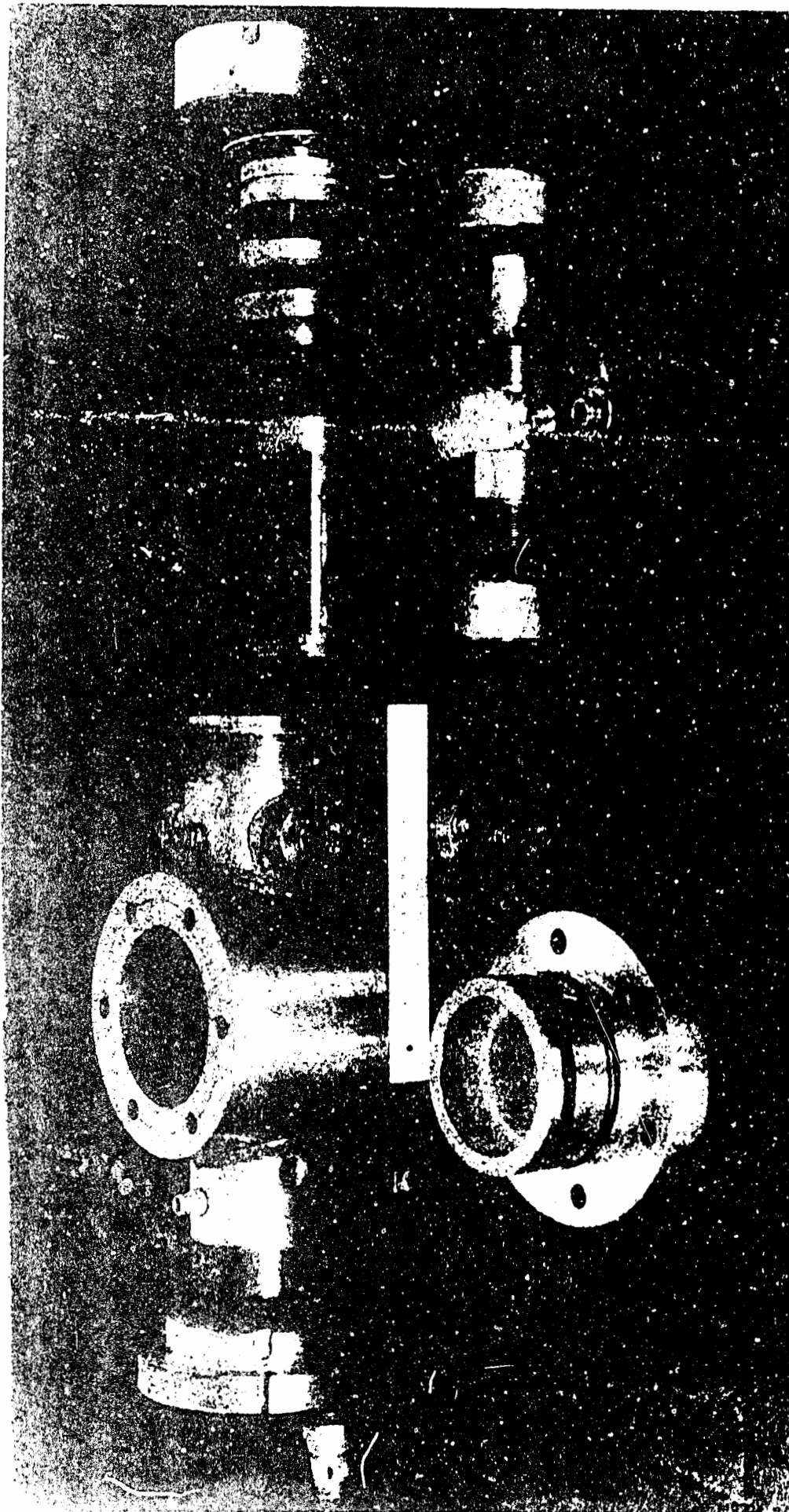

FIG. 3 COMPONENTS OF THE COMBUSTION CHAMBER

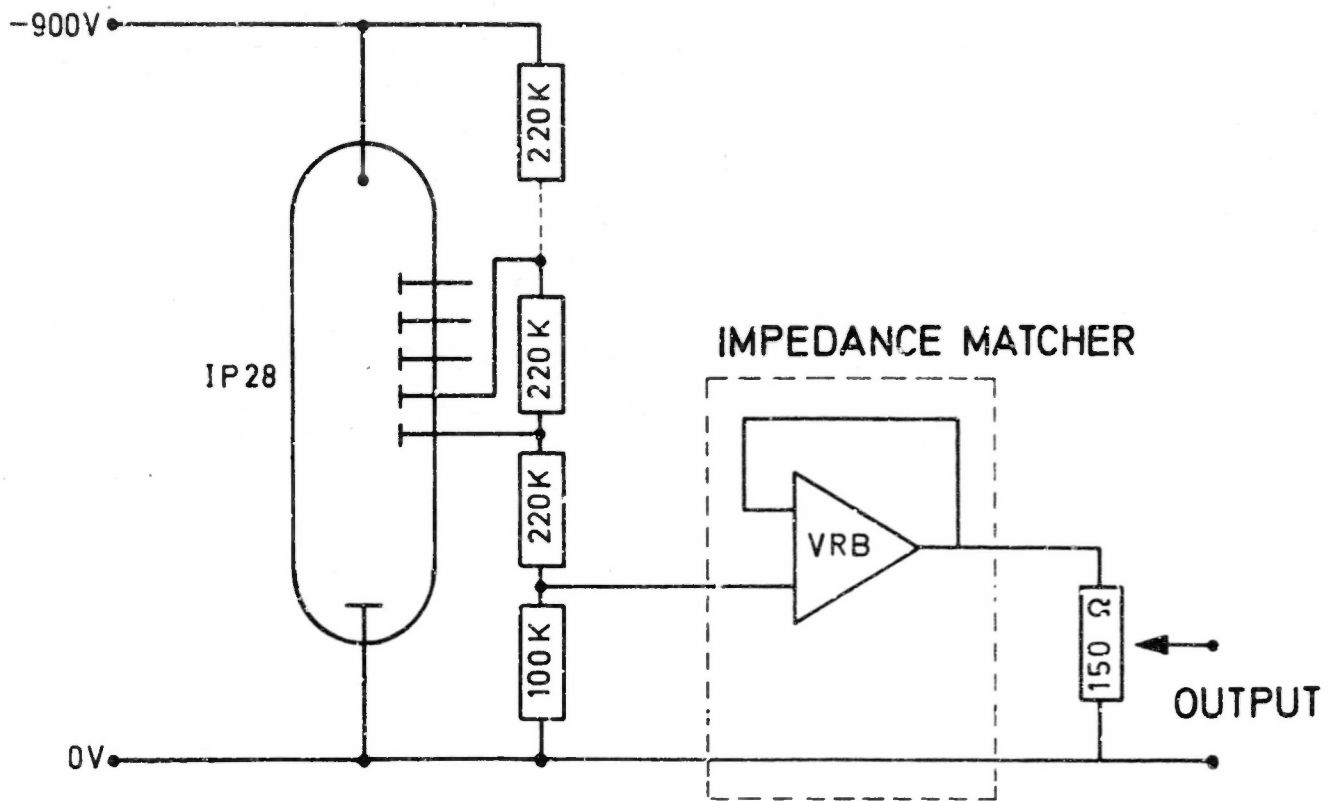

FIG. 3

PHOTOMULTIPLIER CIRCUIT

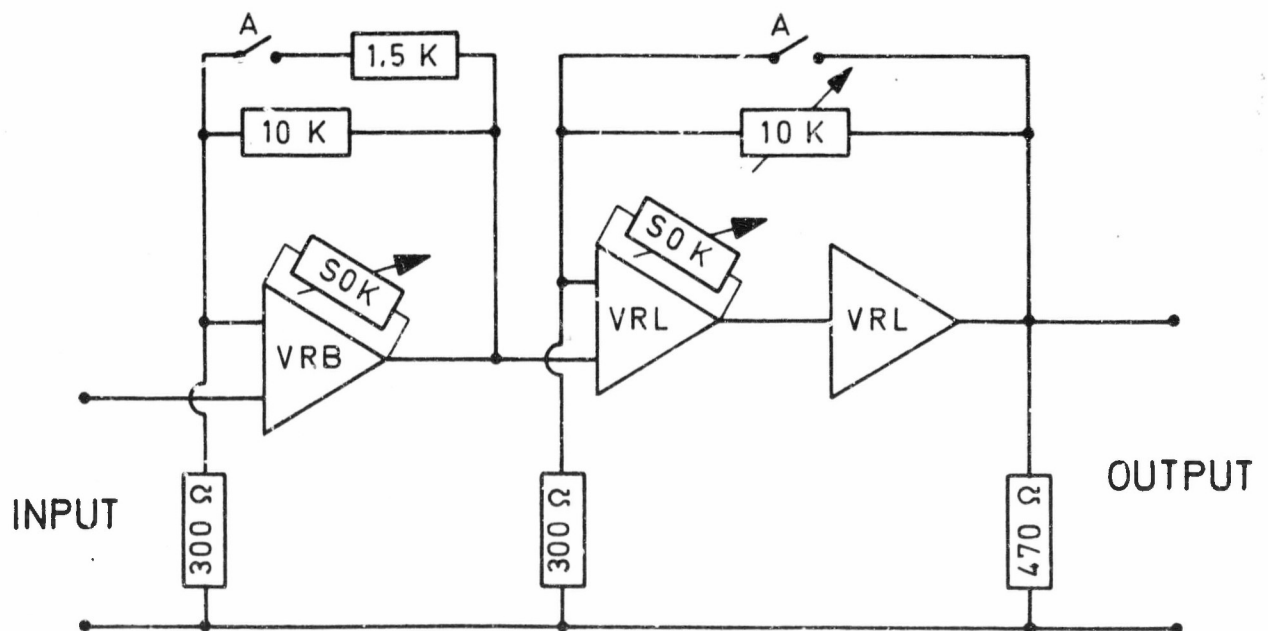
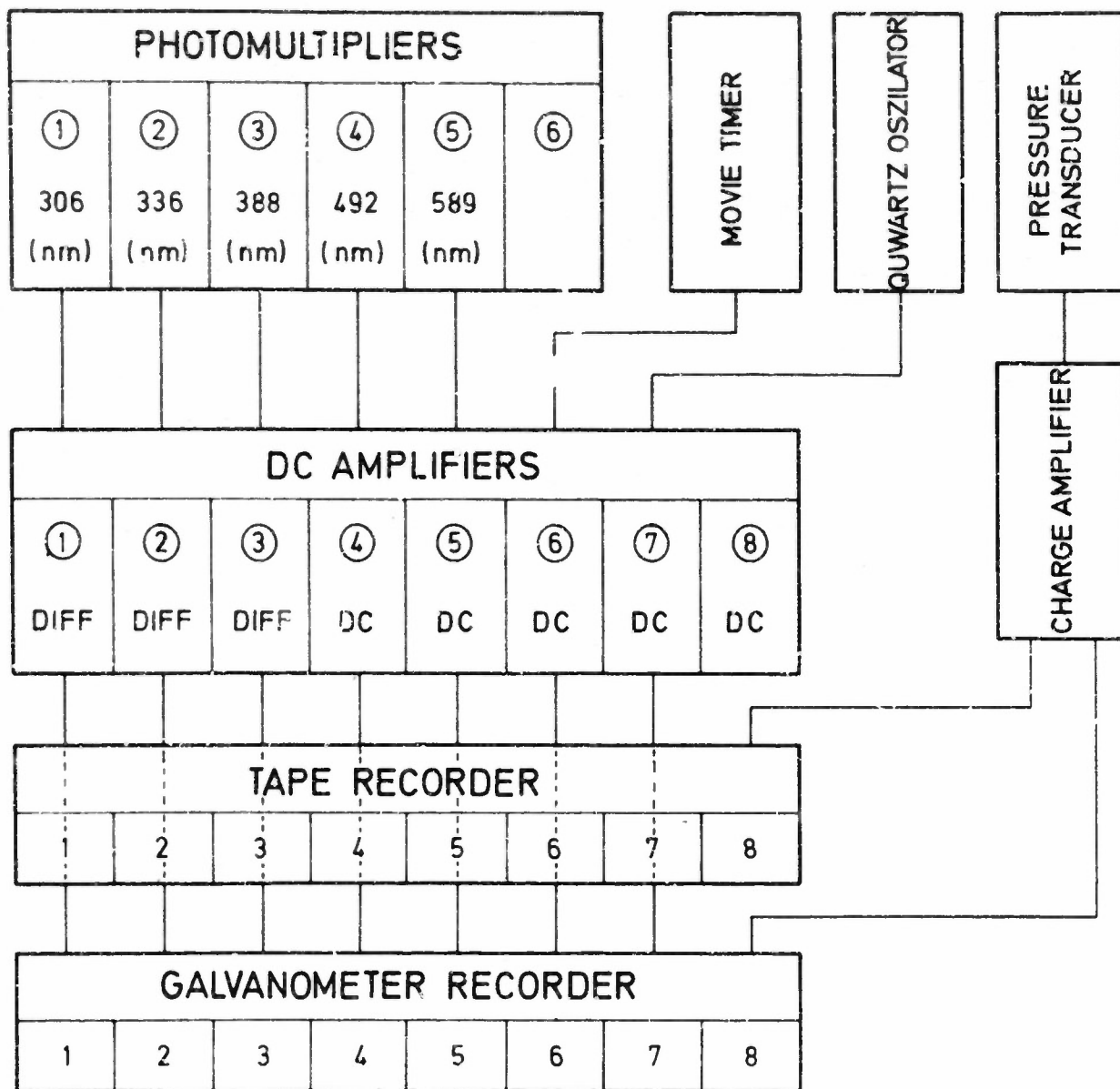

FIG. 4

DC AMPLIFIER CIRCUIT

DFVLR-TRAUEN



(a) DURING TEST

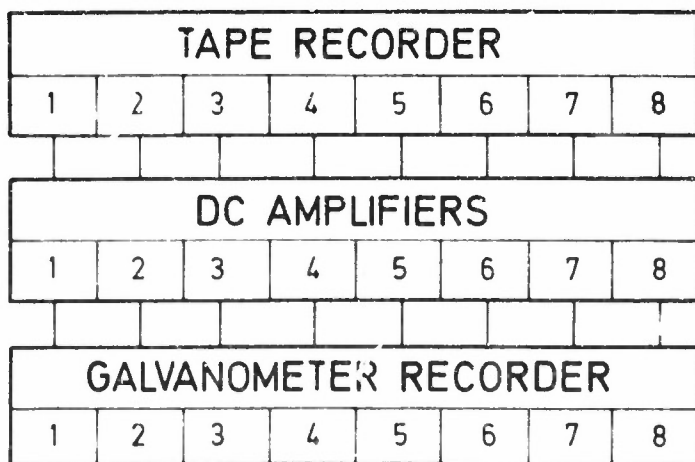

(b) TAPE PLAYBACK

FIG. 5

SCHMATIC OF INSTRUMENTATION

DFVLR-TRAUEN

GALVO. DEFLECTION (mm)

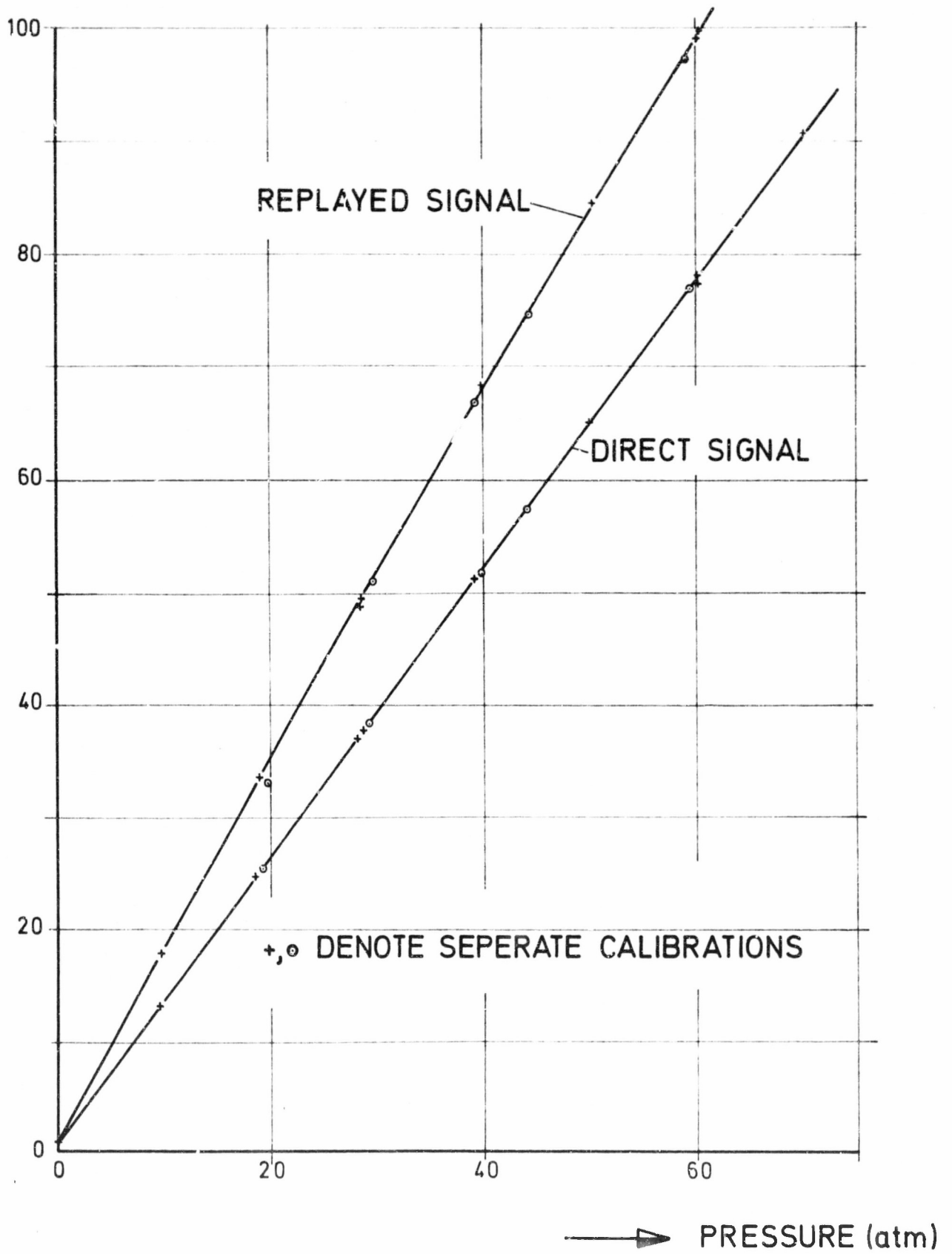

FIG. 6

PRESSURE CALIBRATIONS

DFVLR-TRAUEN

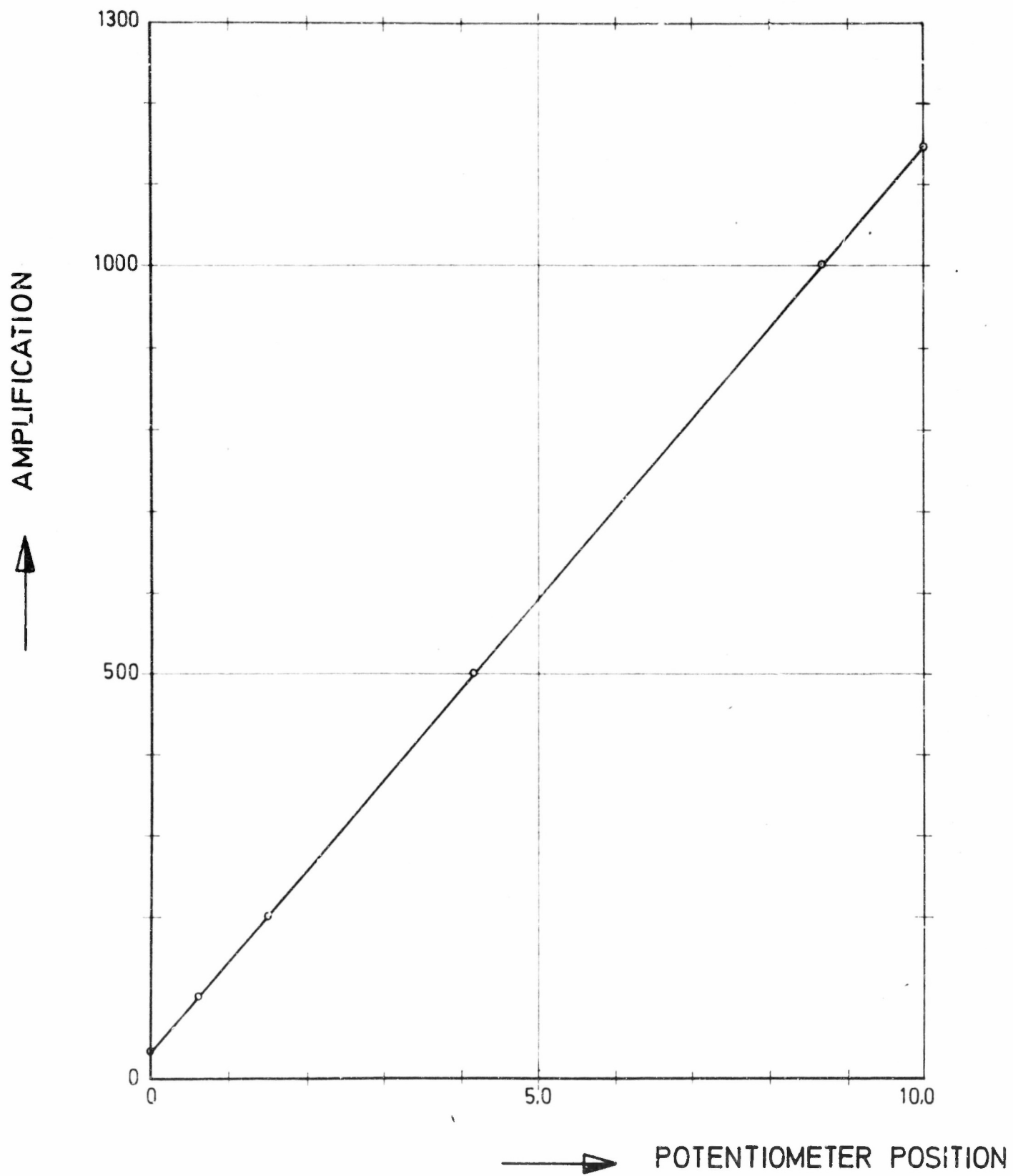

FIG. 7

FUBA AMPLIFIER AMPLIFICATION

DFVLR-TRAUEN

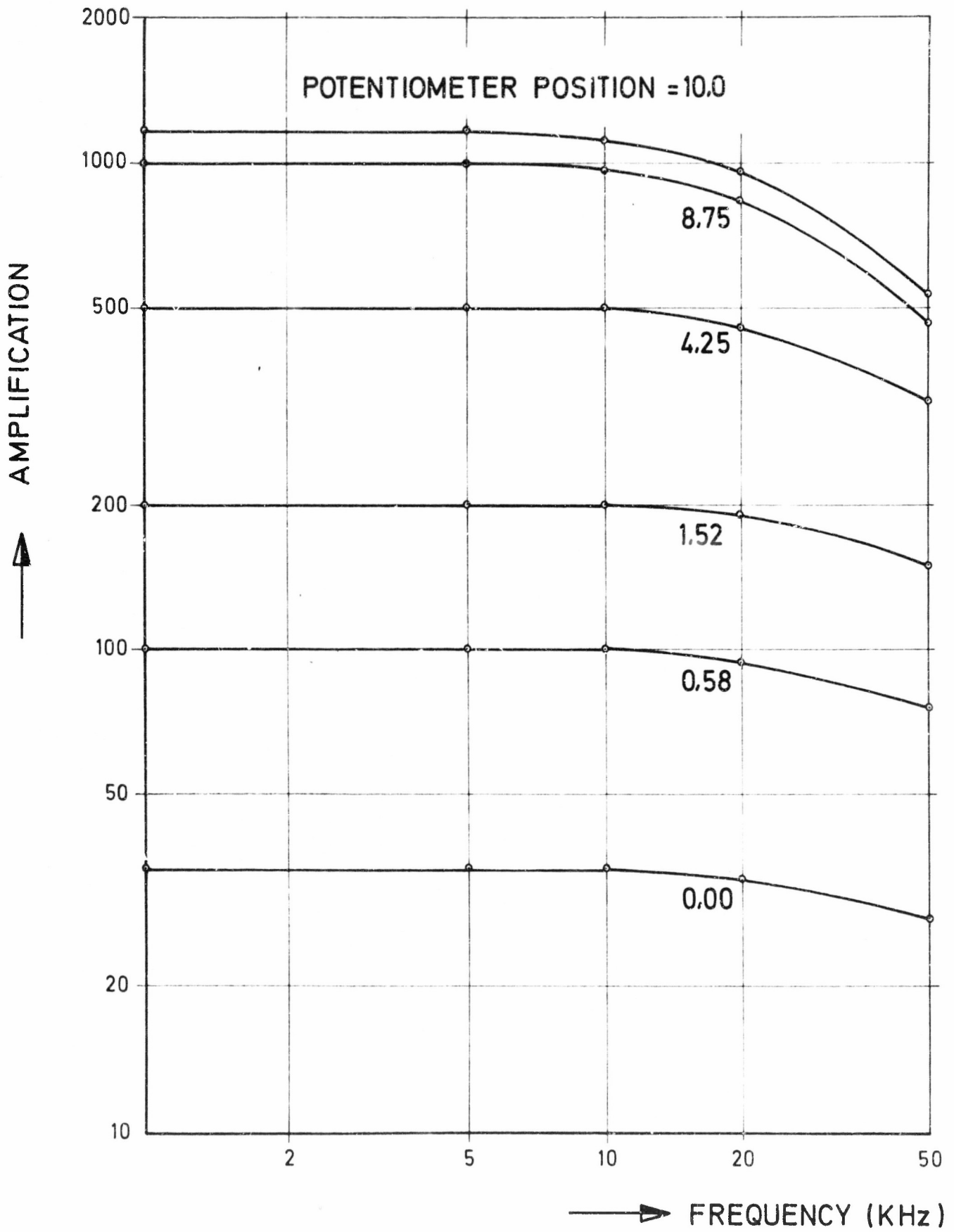
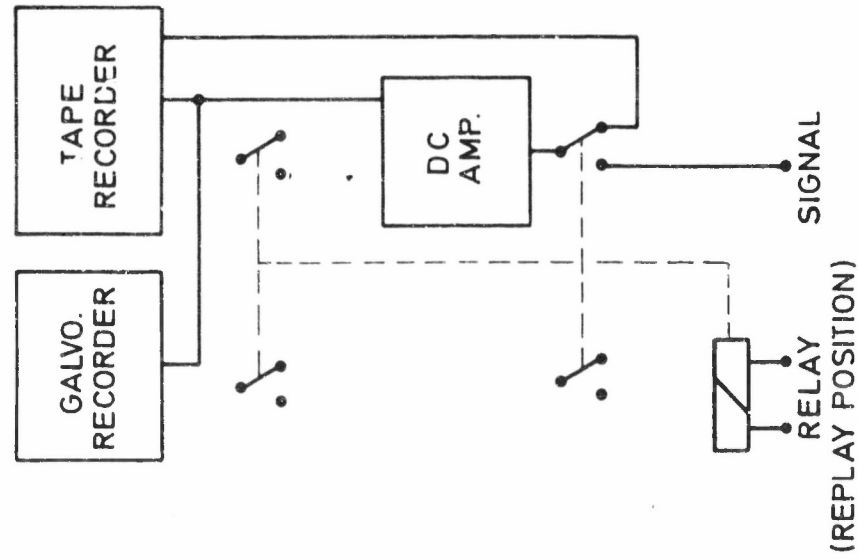
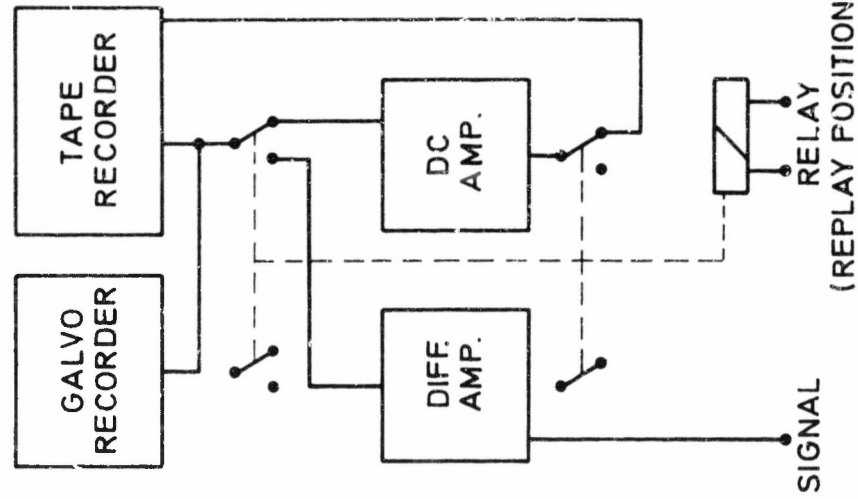

FIG. 8

FUBA AMPLIFIER FREQUENCY RESPONSE DFVLR-TRAUEN



CHANNELS : 492 nm, 589 nm
TIMING MARKS



CHANNELS : 306 nm, 336 nm
and 388 nm

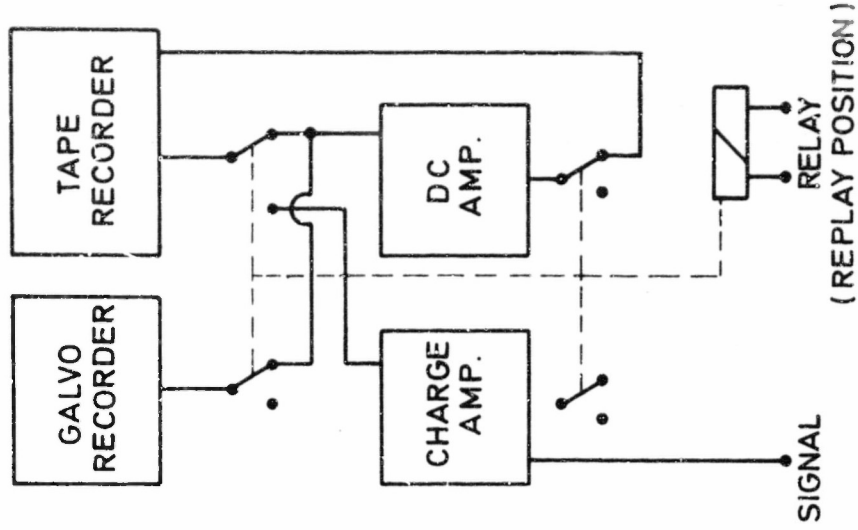

CHANNEL : PRESSURE

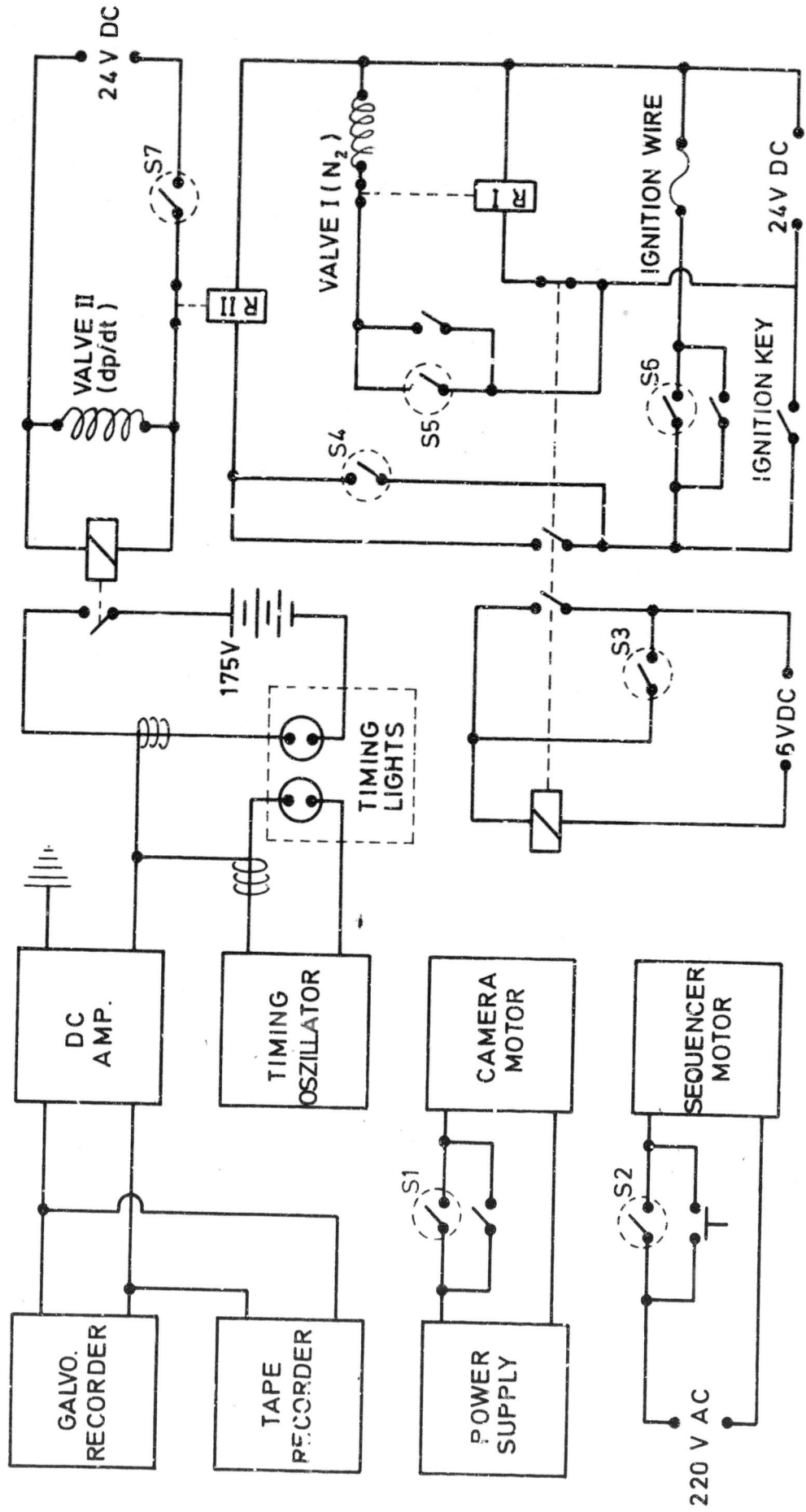

S1, 2, ARE SEQUENCER SWITCHES; R I, II ARE ADJUSTABLE DELAY-TIME RELAYS

FIG.10

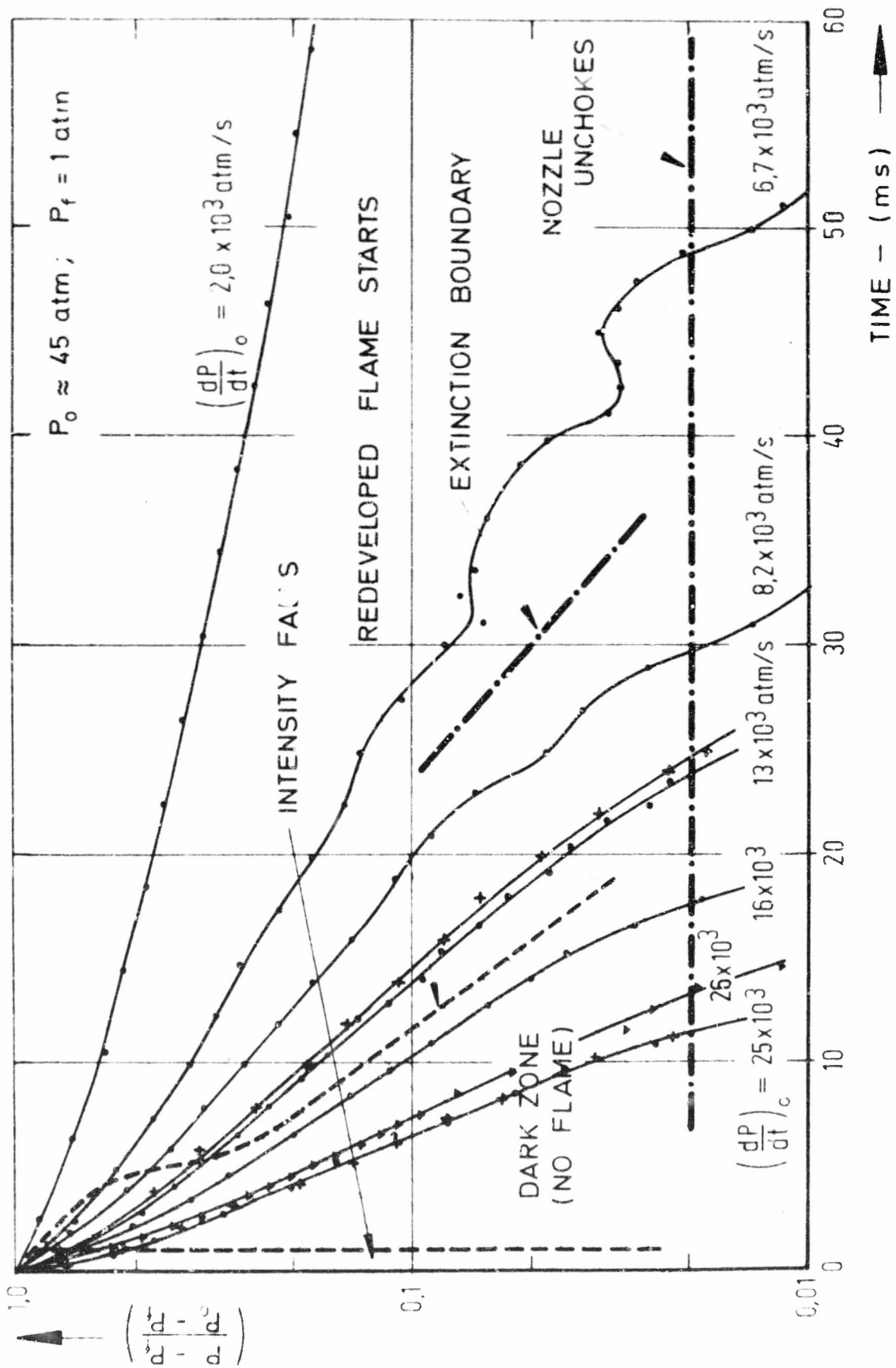
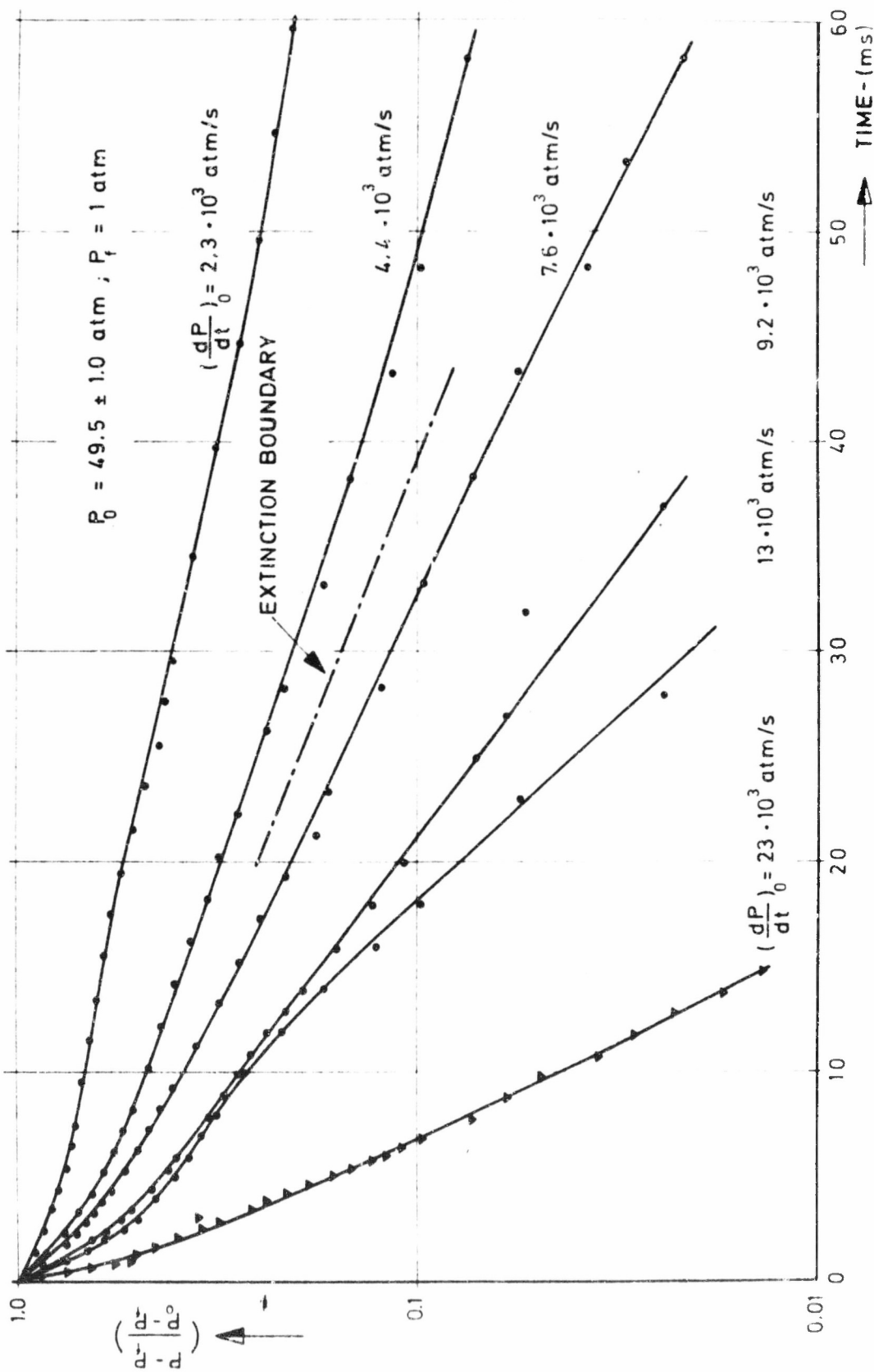

FIG. 1
 MEASURED PRESSURE AND FLAME BEHAVIOR DURING DEPRESSURIZATIONS FOR 24% PBCT + 76% AP (25 μ)

DEVLR-TRAUEN



MEASURED PRESSURE AND FLAME BEHAVIOR DURING DEPRESSURIZATIONS FOR
 24% PBCT + 76% AP (5 μ)

DFVLR-TRAUEN

FIG 12

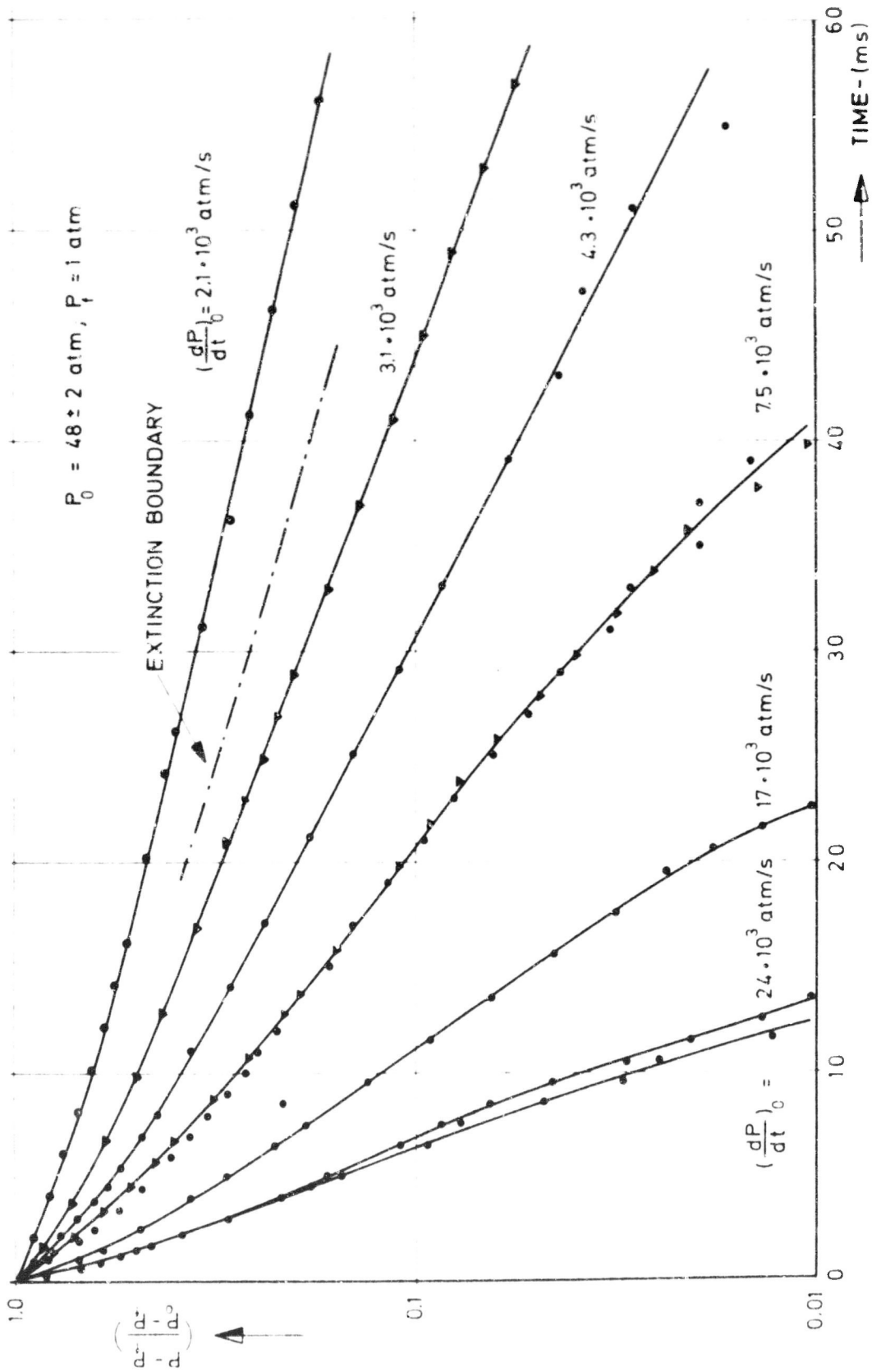

MEASURED PRESSURE AND FLAME BEHAVIOR DURING DEPRESSURIZATIONS FOR
 24% PBCT + 76% AP (100 μ)

DFVLR-TRAUEN

FIG 13

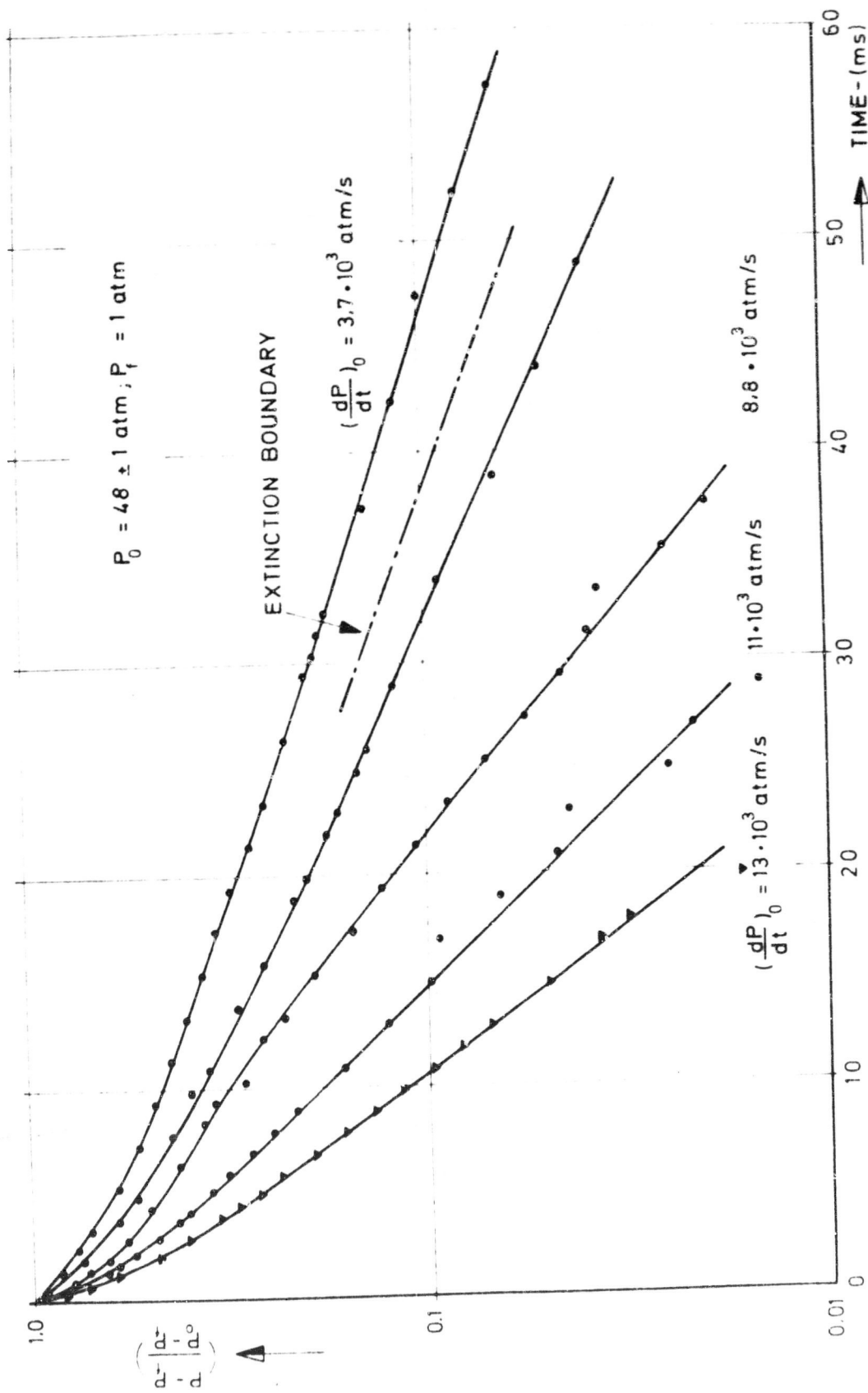

MEASURED PRESSURE AND FLAME BEHAVIOR DURING DEPRESSURIZATIONS FOR
 24% PBCT + 76% AP (25 μ)

DFVLR-TRAUEN

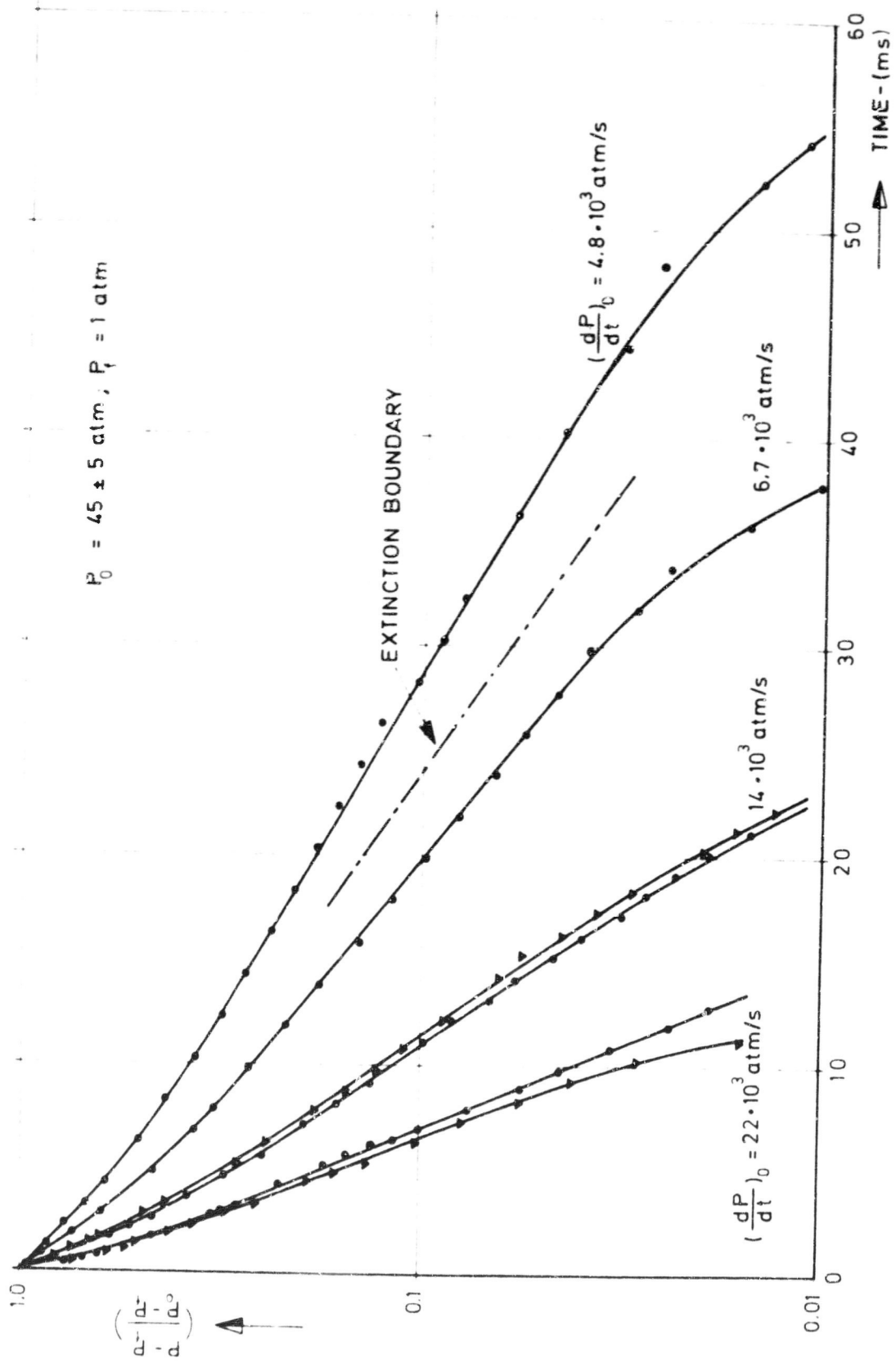

MEASURED J PRESSURE AND FLAME BEHAVIOR DURING DEPRESSURIZATIONS FOR
 24% PBCT + 76% AP (200 μ)

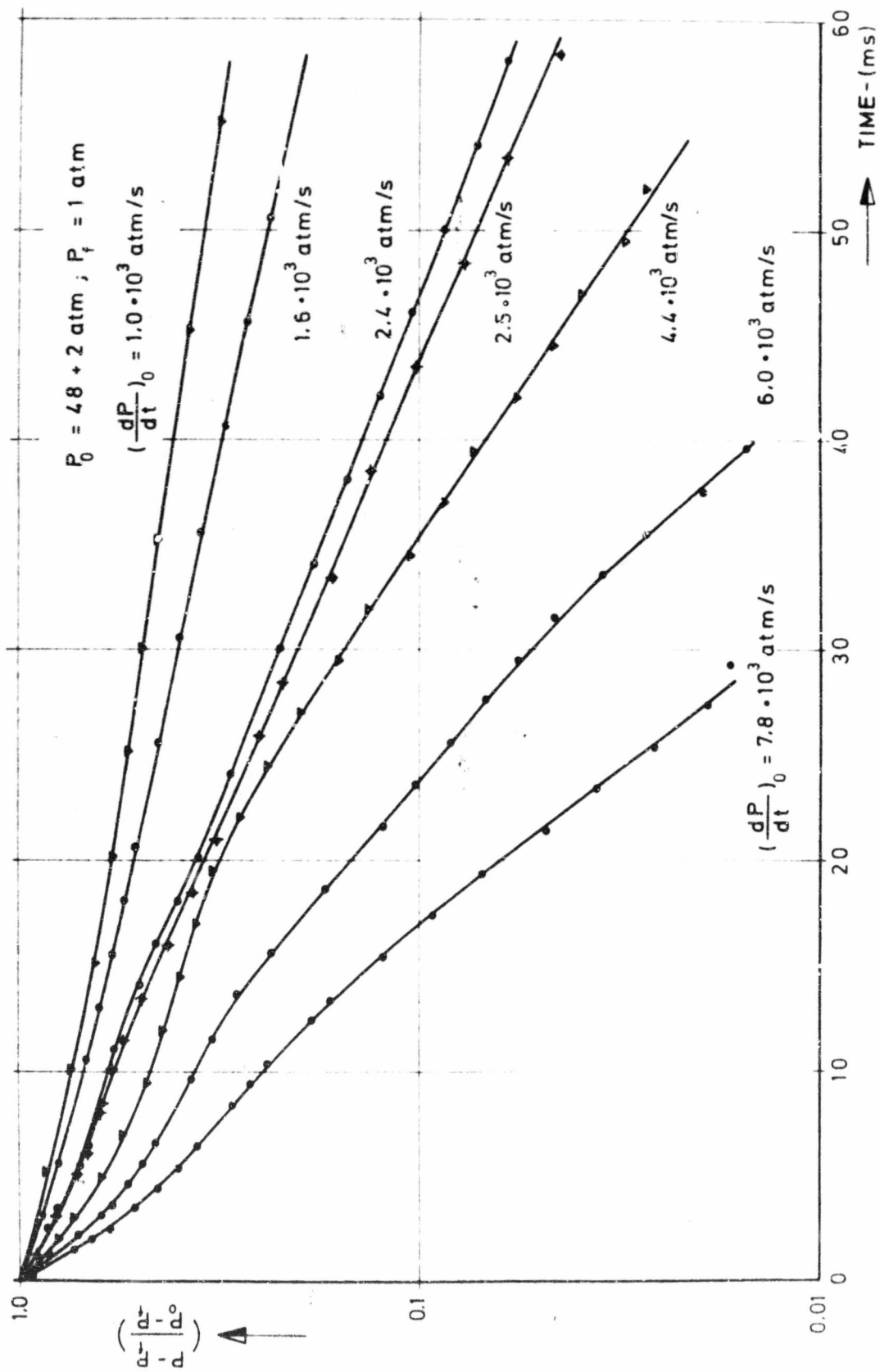

MEASURED PRESSURE AND FLAME BEHAVIOR DURING DEPRESSURIZATIONS FOR

21% PU + 79% AP (150 μ)

DFVLR-TRAUEN

FIG 16

UNCLASSIFIED

Security Classification

DOCUMENT CONTROL DATA -- R & D		
<i>(Security classification of title, body of abstract and indexing annotation must be entered when the overall report is classified)</i>		
1. ORIGINATING ACTIVITY (Corporate author, <i>if available</i>) DEUTSCHE FORSCHUNGS- u. VERSUCHSANSTALT FUR LUFT- und INSTITUT FUR CHEMISCHE RAKETENANTRIEBE 3041 TRAUEN, WEST GERMANY		2a. REPORT SECURITY CLASSIFICATION UNCLASSIFIED 2b. GROUP
3. REPORT TITLE COMBUSTION MECHANISM OF COMPOSITE PROPELLANTS DURING DEPRESSURIZATION		
4. DESCRIPTIVE NOTES (Type of report and inclusive dates) Scientific Interim		
5. AUTHOR(S) (First name, middle initial, last name) J A STEINZ H SELZER		
6. REPORT DATE 31 January 1971	7a. TOTAL NO. OF PAGES 27	7b. NO. OF REFS 2
8a. CONTRACT OR GRANT NO. F61052-70-C-0013	9a. ORIGINATOR'S REPORT NUMBER(S) PROGRESS REPORT #2	
b. PROJECT NO. 9711-01 61102F 681308	9b. OTHER REPORT NO(S) (Any other numbers that may be assigned to this report) AFOSR-TR- 71- 093 1	
10. DISTRIBUTION STATEMENT 1. This document has been approved for public release and sale; its distribution is unlimited.		
11. SUPPLEMENTARY NOTES TECH, OTHER	12. SPONSORING MILITARY ACTIVITY AF Office of Scientific Research (NAE) 1400 Wilson Boulevard Arlington, Virginia 22209	
13. ABSTRACT Apparatus required to investigate the depressurization extinguishment behavior of solid propellants was constructed and a series of tests was conducted using a number of AP propellant compositions at several pressure levels. The results define more clearly the effects of these parameters on the dynamic behavior of the flame. A summary of the findings plus a detailed description of the apparatus and procedures used is given in the report.		

DD FORM 1 NOV 68 1473

UNCLASSIFIED

14

KEY WORDS	LINK A		LINK B		LINK C	
	ROLE	WT	ROLE	WT	ROLE	WT
COMBUSTION INSTABILITY						
COMBUSTION MECHANISMS						
SOLID PROPELLANTS						
EXTINGUISHMENT						