

RESEARCH AND DEVELOPMENT TECHNICAL REPORT
ECOM-0059-1



OPTOELECTRONIC ELECTRON EMITTER

SEMIANNUAL REPORT

BY

H. SCHADE, H. NELSON, AND H. KRESSEL

JULY 1971

SPONSORED BY: ADVANCED RESEARCH PROJECTS AGENCY
ARPA ORDER NO. 1686

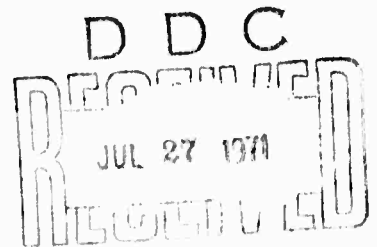

DISTRIBUTION STATEMENT
Approved for public release; distribution unlimited.

.....
ECOM

UNITED STATES ARMY ELECTRONICS COMMAND · FORT MONMOUTH, N.J.

CONTRACT DAAB07-71-C-0059
RCA LABORATORIES
PRINCETON, N. J. 08540

Reproduced by
NATIONAL TECHNICAL
INFORMATION SERVICE
Springfield, Va. 22151

AD 726941

BLANK PAGE

APPROPRIATION FOR		
CFSTI	WHITE SECTION	<input checked="" type="checkbox"/>
DDC	BLUE SECTION	<input type="checkbox"/>
UNANNOUNCED		<input type="checkbox"/>
JUSTIFICATION		
BY		
DISTRIBUTION/AVAILABILITY CODES		
DIST.	AVAIL. and/or	SPECIAL
A		

NOTICES

Disclaimers

The views and conclusions contained in this document are those of the authors and should not be interpreted as necessarily representing the official policies, either expressed or implied, of the Advanced Research Projects Agency or the U.S. Government.

UNCLASSIFIED

Security Classification

DOCUMENT CONTROL DATA - R & D

(Security classification of title, body of abstract and indexing annotation must be entered when the overall report is classified)

1. ORIGINATING ACTIVITY (Corporate author) RCA Laboratories Princeton, N. J. 08540		2a. REPORT SECURITY CLASSIFICATION Unclassified	
		2b. GROUP N/A	
3. REPORT TITLE OPTOELECTRONIC ELECTRON EMITTER			
4. DESCRIPTIVE NOTES (Type of report and inclusive dates) Semiannual Report 15 October 1970 - 14 April 1971			
5. AUTHOR(S) (First name, middle initial, last name) Horst Schade Herbert Nelson Henry Kressel			
6. REPORT DATE July 1971	7a. TOTAL NO. OF PAGES 20	7b. NO. OF REFS 7	
8a. CONTRACT OR GRANT NO. DAAB07-71-C-0059	8b. ORIGINATOR'S REPORT NUMBER(S)		
b. PROJECT NO. 79 1021 7034401			
c.	8d. OTHER REPORT NO(S) (Any other numbers that may be assigned this report) ECOM-0059-1		
d.			
10. DISTRIBUTION STATEMENT Approved for public release; distribution unlimited.			
11. SUPPLEMENTARY NOTES ARPA Order No. 1686		12. SPONSORING MILITARY ACTIVITY U. S. Army Electronics Command Fort Monmouth, N. J. 07703 AMSEL-KL-TQ	
13. ABSTRACT An improved optoelectronic cold-cathode emitter structure has been developed which is grown completely by liquid-phase epitaxy. The combination of an efficient $Al_{1-x}Ga_xAs$ light-emitting diode and long diffusion length GaAs:Ge layer has yielded a device emitting as much as $3 A/cm^2$ (pulsed) with an overall efficiency of 1.6% (vacuum current/diode current). Continuous operation was obtained at a current density of $0.4 A/cm^2$ with an efficiency of 0.43%, which was sustained for a period of 8 hr in a dynamic vacuum system.			

DD FORM 1 NOV 65 1473

UNCLASSIFIED
Security Classification

14 KEY WORDS	LINK A		LINK B		LINK C	
	ROLE	WT	ROLE	WT	ROLE	WT
Optoelectronics Optoelectronic emitters Emitter structure GaAs Gallium arsenide						

TECHNICAL REPORT ECOM-0059-1

REPORTS CONTROL SYMBOL
OSD-1366
JULY 1971

OPTOELECTRONIC ELECTRON EMITTER

SEMIANNUAL REPORT

15 OCTOBER 1970 TO 14 APRIL 1971

CONTRACT NO. DAAB07-71-C-0059 DA PROJECT NO. 7910217034401

ARPA ORDER NO. 1686 DATE OF CONTRACT: 10/21/70
PROGRAM CODE NO. OD10 AMOUNT OF CONTRACT: \$61,500

DISTRIBUTION STATEMENT

Approved for public release; distribution unlimited.

PREPARED BY

H. SCHADE, PRINCIPAL INVESTIGATOR (TEL. EXT.: 2910)

H. NELSON

H. KRESSEL, PROJECT SCIENTIST AND SUPERVISOR (TEL. EXT.: 2427)

RCA LABORATORIES
TEL.: (609) 452-2700
PRINCETON, NEW JERSEY 08540

FOR

U. S. ARMY ELECTRONICS COMMAND, FORT MONMOUTH, NEW JERSEY 07703

FOREWORD

This Semiannual Report describes research performed at RCA Laboratories in the Semiconductor Device Research Laboratory, L. R. Weisberg, Director. The Project Supervisor is H. Kressel. The Technical Staff consisted of Dr. H. Schade, Principal Investigator, H. Nelson (Consultant), and Dr. M. Ettenberg. B. Smith is the Army COTR. This research was supported by the Advanced Research Projects Agency of the Department of Defense and was monitored by the U.S. Army Electronics Command (ECOM) under Contract No. DAAB07-71-C-0059.

ABSTRACT

An improved optoelectronic cold-cathode emitter structure has been developed which is grown completely by liquid-phase epitaxy. The combination of an efficient $\text{Al}_{1-x}\text{Ga}_x\text{As}$ light-emitting diode and long diffusion length GaAs:Ge layer has yielded a device emitting as much as 3 A/cm^2 (pulsed) with an overall efficiency of 1.6% (vacuum current/diode current). Continuous operation was obtained at a current density of 0.4 A/cm^2 with an efficiency of 0.43%, which was sustained for a period of 8 hr in a dynamic vacuum system.

BLANK PAGE

TABLE OF CONTENTS

Section	Page
I. INTRODUCTION	1
II. DEVICE DESCRIPTION	2
III. DEVICE FABRICATION	4
IV. EXPERIMENTAL TECHNIQUES.	6
V. EXPERIMENTAL RESULTS	8
VI. CONCLUSIONS.	10
VII. FUTURE PLANS	11
REFERENCES	12

LIST OF ILLUSTRATIONS

Figure	Page
1. Cold-cathode structure.	2
2. Graphite boat used in growth of optoelectronic cathode material	4
3. Photomicrograph showing cross section of optoelectronic cathode material.	5
4. Circuit configuration used to measure cold-cathode emission	6
5. Emitted current as a function of the pulsed diode current	8

I. INTRODUCTION

The development of semiconductor cold-cathode emitters suitable for vacuum tube applications has been motivated by the need for emitters that have smaller electron velocity distributions (for better focusing of the electron beam) than present hot cathodes, can be readily modulated, are capable of being fabricated in array form, have long life, and do not require the heat shielding which complicates tube construction.

The present research program concentrates on GaAs p-n junction structures which rely on negative electron affinity surfaces[1] to obtain high electron emission efficiency at room temperature. This allows electron escape probabilities in excess of 10%. The electrons to be emitted can be generated either by direct injection into the surface region or by first generating light (electroluminescence) which is absorbed in a p-type surface layer that acts as a photoemitter. Devices involving the latter characteristic are called optoelectronic cold cathodes[2]; they avoid current constriction in the vicinity of the ohmic contact to the emitting surface which is frequently a major problem in cold cathodes using direct injection.

The objective of this contract is to determine the feasibility of an optoelectronic electron emitter operating at a minimum current efficiency (defined as the ratio of emission current/diode current) of 1% and at an emission current density of ≈ 100 mA/cm². The present program is based on the previous encouraging performance at RCA Laboratories of a structure which consisted of a silicon-compensated Al_{1-x}Ga_xAs electroluminescent diode covered with an absorbing p-type GaAs:Zn layer having a negative electron affinity surface. An efficiency of 0.11% at an emission current density of 1 mA/cm² had been achieved under conditions which were known to be far from optimum. Based on these initial results, the objective of the present contract was planned to be reached with the following program:

- (1) Optimization of the various structural parameters of the device such as doping, electron diffusion length, layer thicknesses, contacting, and surface activation, -- all in order to achieve at least the required efficiencies and emission current densities.
- (2) Life testing under pulsed and dc conditions at varying anode voltages. In particular, it is of interest to determine whether cold-cathode operation is feasible with anode voltages of several thousand volts, a requirement for some applications (such as the EBIT).

II. DEVICE DESCRIPTION

The cold-cathode structures consist of $\text{Al}_{1-x}\text{Ga}_x\text{As}:\text{Si}$ electroluminescent diodes covered with a thin top layer of $\text{GaAs}:\text{Ge}$ whose surface is activated with cesium and oxygen. Electron emission from such a structure is obtained as follows (see Figure 1): Under forward bias, electrons are injected into the p-type $\text{Al}_{1-x}\text{Ga}_x\text{As}$ region where they recombine radiatively. The emitted photons ($h\nu = 1.41 - 1.6 \text{ eV}$) are strongly absorbed in the highly p-type GaAs surface layer ($E_g = 1.42 \text{ eV}$), thus creating electron-hole pairs. A substantial number of the electrons that diffuse to the surface are then emitted into vacuum, provided the surface has been activated to a condition of an effective negative electron affinity. A major advantage of this device is that current constriction is minimized, allowing the fabrication of large-area emitters.

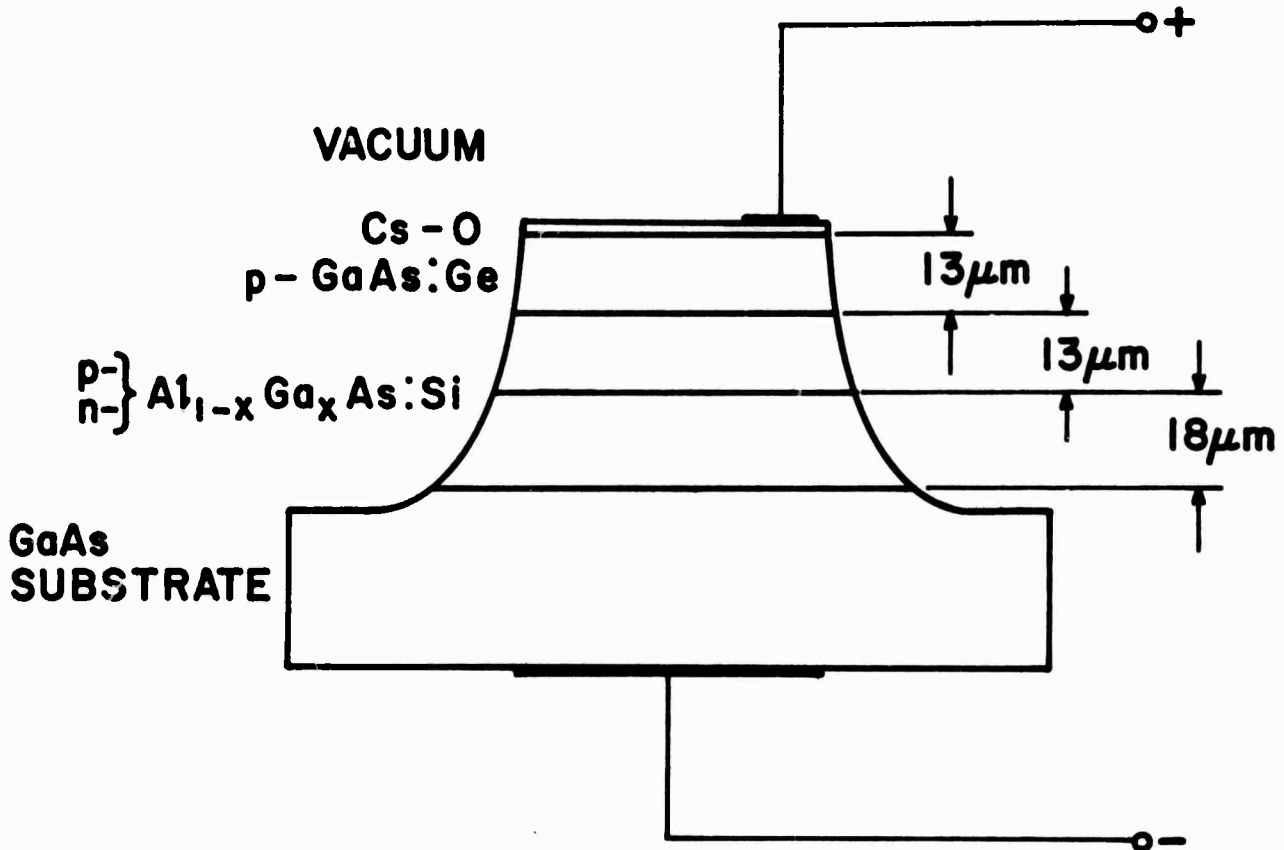

Figure 1. Cold-cathode structure.

In contrast with the previous structure[2], the devices described here were prepared solely by liquid-phase epitaxy[3]. The electroluminescent diode emission peaked at 8700 to 8800 Å. A thick (10 to 13 μm) $\text{GaAs}:\text{Ge}$ layer was used with a hole concentration of about $5 \times 10^{17} \text{ cm}^{-3}$ in place of the previous thin (about 1 μm) Zn-doped layer with a concentration of about $1 \times 10^{19} \text{ cm}^{-3}$ prepared by vapor-phase epitaxy. $\text{GaAs}:\text{Ge}$ layers were used, because their electron diffusion lengths had been previously found[4] to measure typically between 5 and 7 μm, and can be well controlled by liquid-phase epitaxial growth[5]. The

thick p-type region is desirable to more fully absorb the light emitted by the $\text{Al}_{1-x}\text{Ga}_x\text{As}$ diode and to minimize current constriction under the ohmic contact. It was not necessary to adjust the growth cycle to control the layer thickness exactly, since we had found previously [4] that chemically polished surfaces (bromine in methanol) could be reproducibly activated to photosensitivities in excess of $800 \mu\text{A}/\text{lm}$. Thus, the top layer could be thinned to the desired value after growth.

The emitting region ranged from $2 \times 10^{-4} \text{ cm}^2$ to $\sim 10^{-2} \text{ cm}^2$, depending on the diode. Ohmic contact to the n-side of the junction was made by indium, while a point contact was applied to the p-side, a technique which works satisfactorily.

III. DEVICE FABRICATION

Cold-cathode structures as described in Section II are prepared from epitaxial material grown by the liquid-phase process using a graphite boat as shown in the cross section of Figure 2[6]. An n-type GaAs substrate of (100) orientation is placed in a recessed area R of a graphite slide S. A melt composed of Ga, Al, Si, and GaAs is placed in the bin B₁ and another melt composed of Ga, Ge, and GaAs is placed in bin B₂ of the graphite boat. The boat is inserted in a quartz furnace tube and heated in a flow of pure hydrogen to a maximum temperature of about 875°C. The graphite slide is then pulled into a

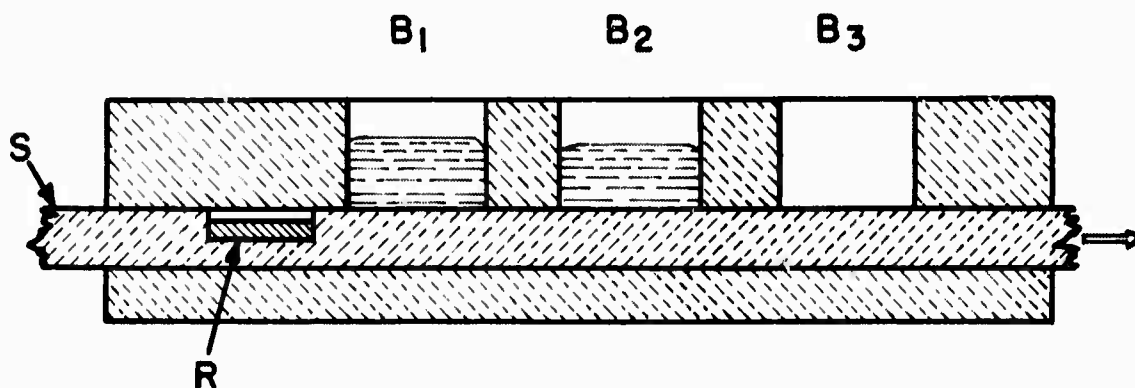

Figure 2. Graphite boat used in growth of optoelectronic cathode material[6].

position such that the substrate in the recessed area R forms the bottom of bin B₁. As the furnace is allowed to cool to a temperature of about 810°C, a Si-doped epitaxial (AlGa)As layer, the first portion of which is n-type and the final portion p-type, is grown onto the surface of the GaAs substrate[7]. The graphite slide is then pulled into the position where the substrate forms the bottom of bin B₂. Upon further cooling to about 750°C, precipitation from the melt in this bin results in the growth of a Ge-doped, p-type GaAs surface layer. The processed substrate is then pulled into the empty bin B₃, and the furnace is allowed to cool to a temperature at which the graphite boat can be removed from the furnace. A photomicrograph of a cross section of a portion of a "cold-cathode wafer," prepared as described above, is shown in Figure 3. The Ge-doped surface layer is reduced to a thickness of about 10 μm by lapping and chemical polishing after which cold-cathode structures as shown in Figure 1 are fabricated from the processed wafer by masking and etching techniques.

Numerous cold-cathode wafers of the type described above have been prepared in the course of work directed toward the determination of doping concentrations, doping gradients (and geometrical parameters) which lead to optimum cold-cathode efficiency.

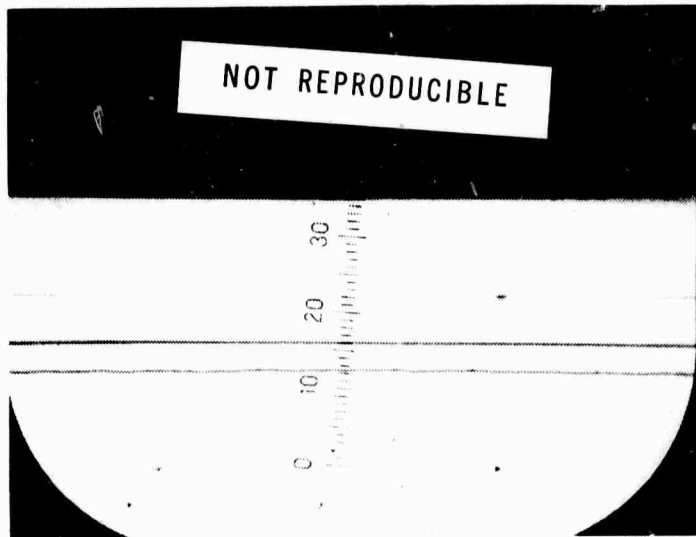

Figure 3. Photomicrograph showing cross section of optoelectronic cathode material.

IV. EXPERIMENTAL TECHNIQUES

After insertion into vacuum (base pressure below 1×10^{-9} Torr), the samples were heat-cleaned by electron bombardment for several minutes at temperatures close to the decomposition temperature of GaAs. The sample surface was then activated by conventional cesium-oxygen treatment to a condition of an effective negative electron affinity. Cesium was provided by heating cesium chromate in a tantalum channel, and oxygen was leaked into the vacuum chamber by heating an attached tube. The activation process was monitored by measuring the white light photoemission from the GaAs top surface. Typically, photosensitivities between 700 and 1000 $\mu\text{A}/\text{lm}$ were obtained.

Upon reaching maximum photosensitivity, cold-cathode emission was measured using the circuit shown in Figure 4. We used two different modes of operation:

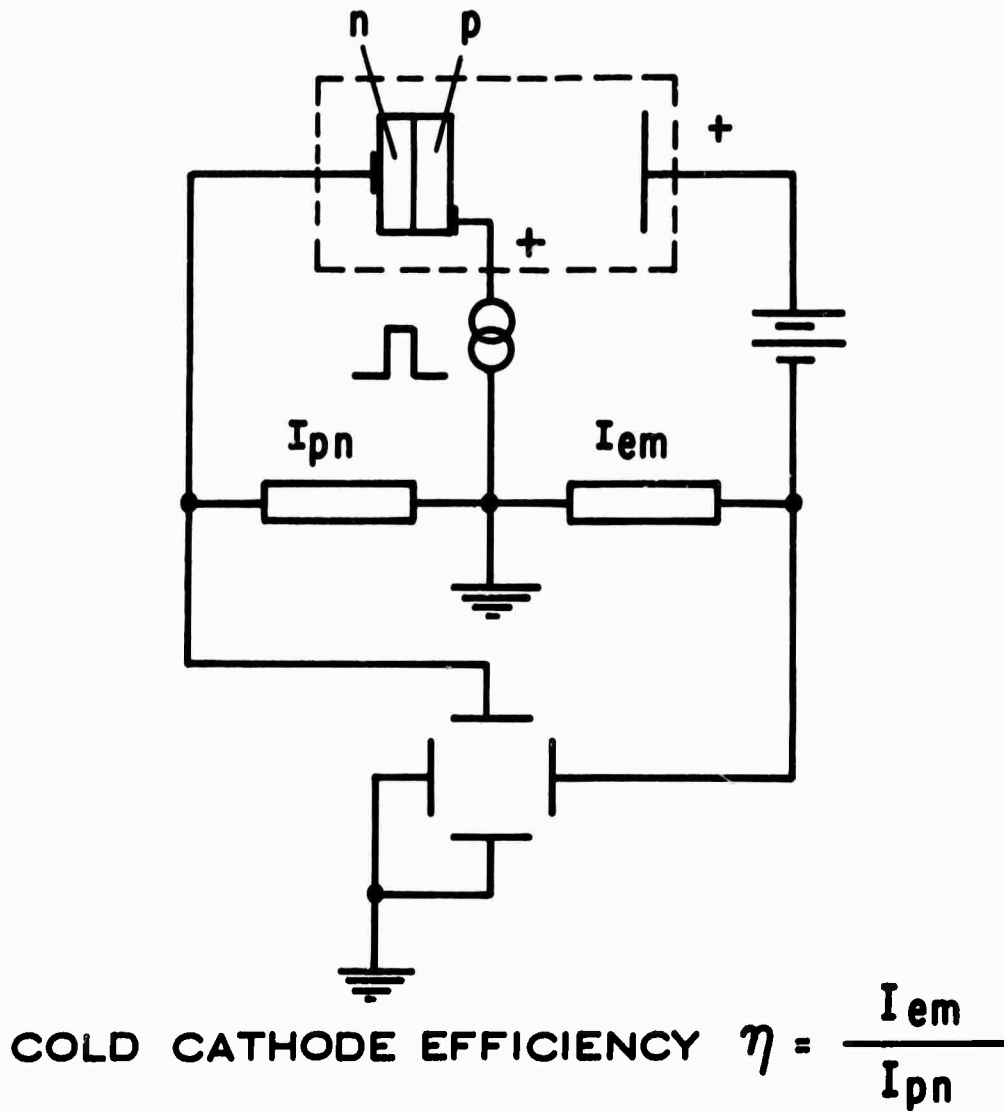

Figure 4. Circuit configuration used to measure cold-cathode emission.

- (1) In the pulsed mode 10- to 100- μ sec pulses (0.1 to 1% duty cycle) are applied to the electroluminescent diode, and the emission current is collected with an anode voltage of about 500 V. This mode of operation avoids heating of the sample as well as space charge limitation of the emission current. Thus, the full capabilities of the device structure can be tested.
- (2) In the dc mode, junction currents of about 10^2 A/cm² can be drawn through the electroluminescent diode without significant heating of the structure. At the same time, the anode voltage is kept below about 30 V in order to eliminate possible sputtering of the emitting surface. This second mode of cold-cathode operation is used to study continuous operation of the cold-cathode structures.

All of the work reported here was with devices mounted in a continuously pumped vacuum system. Cathode operation in a sealed system is, of course, of practical interest. Such work will be undertaken in the second half of this program.

V. EXPERIMENTAL RESULTS

Greatly improved performance of optoelectronic cold-cathode emitters was obtained during the first half of this report period. Our best results to date are compiled in Table I. Figure 5 shows the emitted current as a function of the pulsed diode current (1% duty cycle) of a sample with an overall efficiency of 1.6% at a peak *emission* current density of 3 A/cm² for short times

NOT REPRODUCIBLE

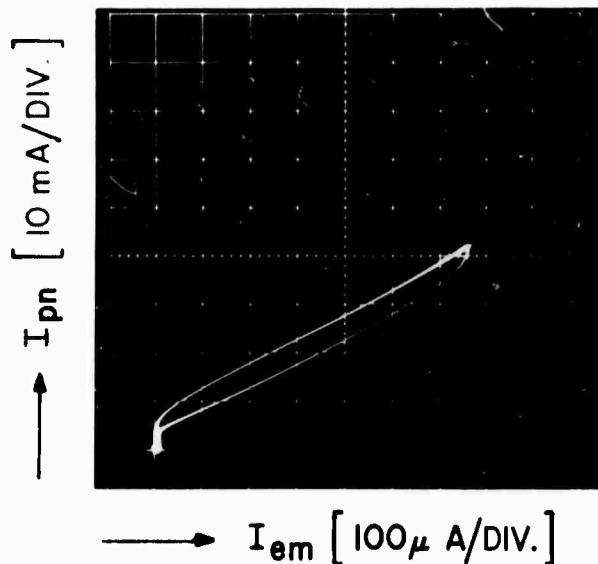

Figure 5. Emitted current as a function of the pulsed diode current.

at an anode voltage of 800 V. Note that because of leakage, emission does not start at zero junction current. The *differential* efficiency, 1.74%, is therefore about 10% higher than the overall efficiency. These values represent the highest ever reported for optoelectronic cold-cathode structures; the previous value with optoelectronic structures was 0.11% efficiency at an emission current density of 0.001 A/cm².

TABLE I

COLD-CATHODE PROPERTIES OF AN
OPTOELECTRONIC GaAs - Al_{1-x}Ga_xAs STRUCTURE

Operation	J _{em} (A/cm ²)	J _{pn} (A/cm ²)	η (%)	V _(anode) (V)
dc	0.4	100	0.4	30
pulsed*	3.2	200	1.6	800
*10 to 100 μsec ≤ 1% duty cycle				

It is to be noted that four more samples of similar construction all yielded emission efficiencies in excess of 0.4%, one of these samples as high as 1.5%. The efficiency differences are probably due mainly to differences in light absorption in the GaAs top layer rather than to differences in surface activation and, thus, surface escape probability. This explanation is suggested by our previous photoemission measurements on similar GaAs surfaces of several samples which could be activated reproducibly to about the same surface escape probabilities.

Cold-cathode emission was also measured under dc conditions. We operated a cold-cathode structure with an emitting area of 2×10^{-4} cm² for 8 hours at an emission current of 80 μA dc (emission current density ~ 0.4 A/cm²), while the output and efficiency at 0.43% remained unchanged. The anode voltage was 30 V. As previously noted, this experiment was performed under dynamic vacuum conditions; however, the activation of the emitting surface may be expected to remain reasonably stable if the cold-cathode is operated in a sealed-off tube.

VI. CONCLUSIONS

An optoelectronic cold-cathode structure was operated at pulsed (1% duty cycle) emission current densities of 3 A/cm^2 at an overall efficiency of 1.6%. Continuous operation for 8 hours at an emission current density of 0.4 A/cm^2 and an efficiency of 0.43% was measured. These results show that devices with practical operating current densities are possible using the device structure described here. The initial results on the operating life are encouraging in that they show that the cathode life is not limited by catastrophic processes.

It is significant that stable operation was obtained when low anode voltages were used. This suggests that damage of the cesiated surface at higher anode voltages was caused by ions released from the anode, an unexpected result. Practical structures will, therefore, have to be designed to prevent sputtering.

VII. FUTURE PLANS

The highest efficiency observed is still less than half of the calculated limit for the devices studied, which leaves room for further improvement. More experiments will be required to adjust structural parameters for optimum device performance. At the same time, emphasis will be placed on studying long-term operation. The initial results on life testing under dynamic vacuum conditions justify future measurements in sealed tubes.

REFERENCES

1. J. J. Scheer and J. van Laar, *Solid State Communications* 3, 189 (1965).
2. H. Kressel, E. S. Kohn, H. Nelson, J. J. Tietjen, and L. R. Weisberg, *Appl. Phys. Letters* 16, 359 (1970).
3. H. Nelson, *RCA Review* 24, 603 (1963).
4. H. Schade, H. Nelson, and H. Kressel, *Appl. Phys. Letters* 18, 121 (1971).
5. H. Kressel, F. Z. Hawrylo, and P. LeFur, *J. Appl. Phys.* 39, 4059 (1967).
6. H. Nelson, U.S. Patent 3,565,702.
7. H. Kressel, F. Z. Hawrylo, and N. Almeleh, *J. Appl. Phys.* 40, 2248 (1969).